

Attachment 3

Monroe Gantry and Layout 50 Percent Plans

09_205/299

TIP PROJECT: R-3329 / R-2559

CONTRACT: C202587

STATE OF NORTH CAROLINA
DIVISION OF HIGHWAYS

MECKLENBURG & UNION COUNTY

LOCATION: US 74 BYPASS FROM US 74 JUST EAST OF I-485 NEAR MATTHEWS AND STALLINGS TO US 74 JUST EAST OF WINGATE AND WEST OF MARSHVILLE
TYPE OF WORK: GRADING, DRAINAGE, PAVING, WIDENING, RESURFACING, STRUCTURES, SIGNALS, SIGNING, LIGHTING, & ITS

STATE	STATE PROJECT REFERENCE NO.	SHEET NO.
N.C.	R-3329 /R-2559	GAN-1
STATE PROJ. NO.	F.A. PROJ. NO.	DESCRIPTION
34533.5TA1		

GANTRY 50% PLANS
SUBMITTAL NO. S-380
DATE: 11/19/2015

INCOMPLETE PLANS
DO NOT USE FOR R/W ACQUISITION
PRELIMINARY PLANS
DO NOT USE FOR CONSTRUCTION

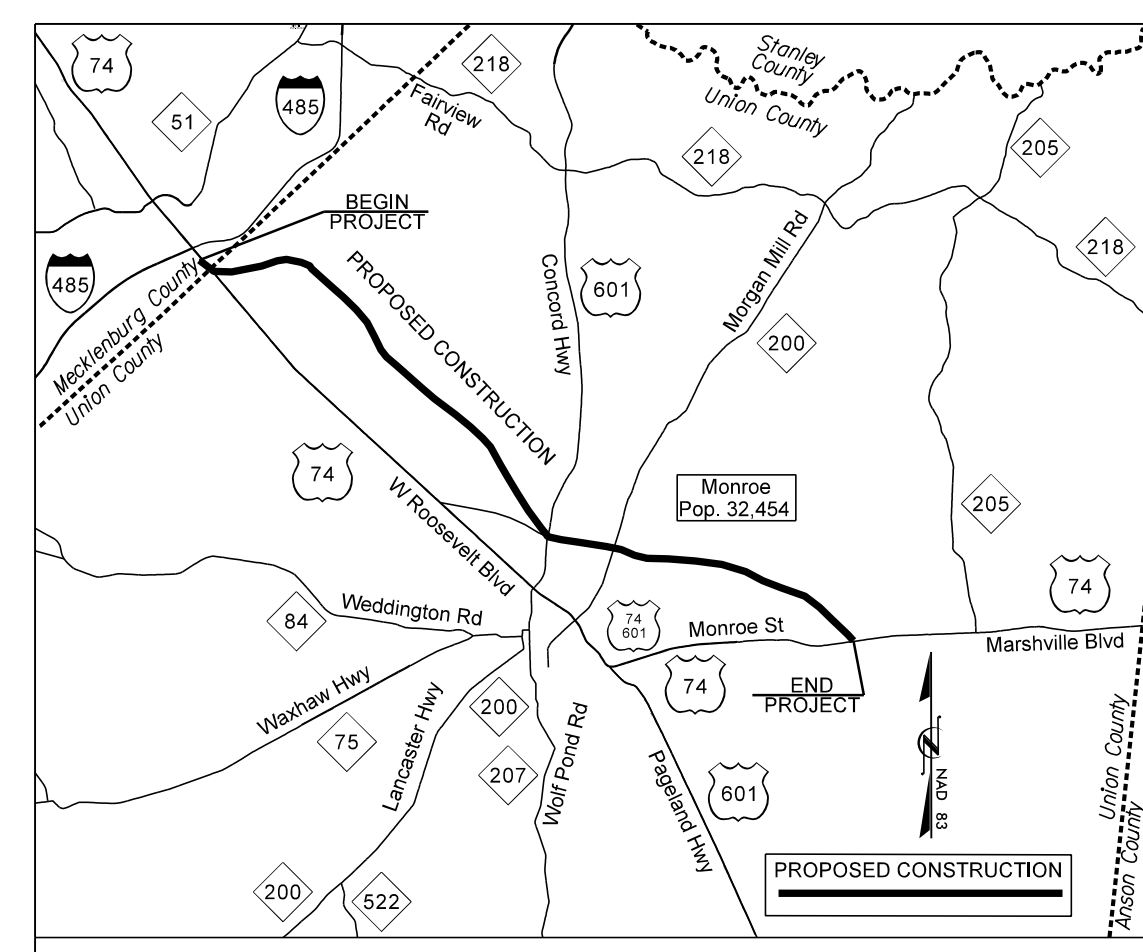

VICINITY MAP

BEGIN TIP PROJECT R-3329 / R-2559
-L- Sta. 110+00.00

END TIP PROJECT R-3329 / R-2559
-L- POT Sta. 1233+50.00

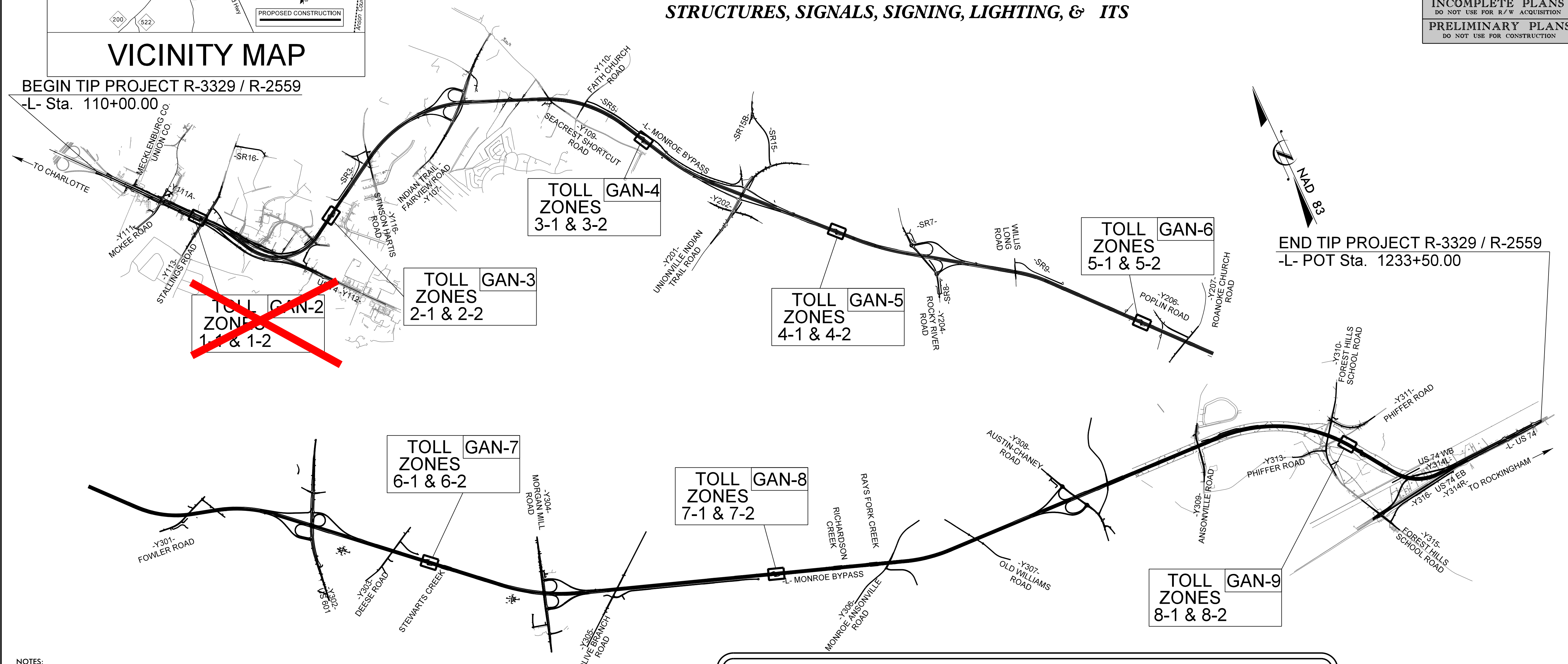

NOTES:
1. THIS IS A CONTROLLED-ACCESS PROJECT WITH ACCESS BEING LIMITED TO INTERCHANGES.

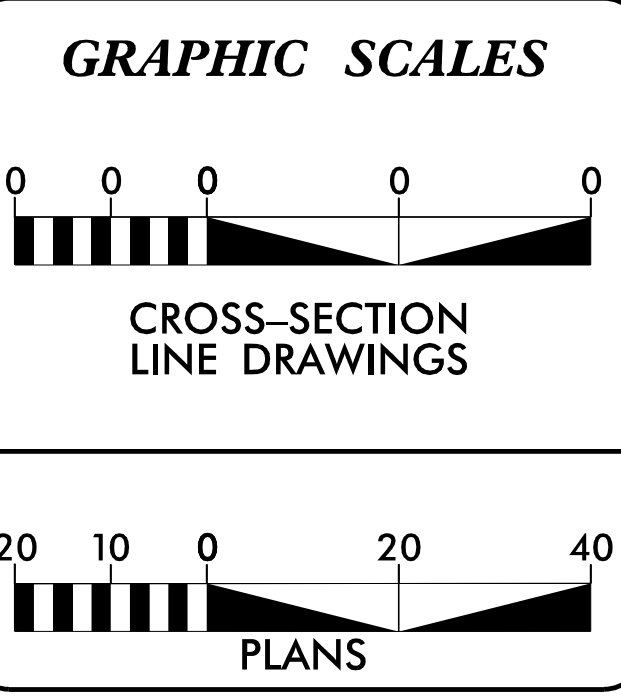

DESIGN DATA

ADT 2013 =	64,100
ADT 2035 =	95,600
DHV =	8%
D =	55%
T =	18%*
V =	70 mph

(*TTST 11% + DUAL 7%)
FUNCTIONAL CLASS.: FREEWAY

PROJECT LENGTH

LENGTH ROADWAY TIP PROJECT R-3329 /R-2559.....	18.1 mi
LENGTH STRUCTURE TIP PROJECT R-3329 /R-2559.....	*1.6 mi
TOTAL LENGTH TIP PROJECT R-3329 /R-2559.....	19.7 mi

* LENGTH OF STRUCTURES BASED ON WB LANES

NCDOT CONTACT: **K. ZAK HAMIDI, P.E.**
DESIGN BUILD UNIT

DESIGN - BUILD TEAM

PLANS PREPARED BY :

RK&K
RUMMEL, KLEPPER & KAHL, LLP
900 RIDGEFIELD DRIVE, SUITE 350
RALEIGH, NORTH CAROLINA 27609
NC LICENSE NO. F-0112

FOR THE NORTH CAROLINA DEPARTMENT OF TRANSPORTATION

2006 STANDARD SPECIFICATIONS

LETTING DATE:
OCTOBER 28, 2010

J.T. Peacock, Jr., P.E.
PROJECT ENGINEER

Stephen E. Roberts, P.E.
PROJECT DESIGN ENGINEER

CONTRACTOR :

MONROE
BYPASS CONSTRUCTORS

TRANSPORTATION ENGINEER

SIGNATURE: _____ P.E.

11/17/2015 R:\Traffic\Signing\CADD\GANTRY PLANS\plansheets\3329_r2559_rdy_AET_tsh SHEET 01.dgn M.H

TIP NO. R-3329/R-2559	SHEET NO. GAN-3
APPROVED: _____	
DATE: _____	
SEAL	
INCOMPLETE PLANS DO NOT USE FOR R/W ACQUISITION	
PRELIMINARY PLANS DO NOT USE FOR CONSTRUCTION	
Name _____	Date _____

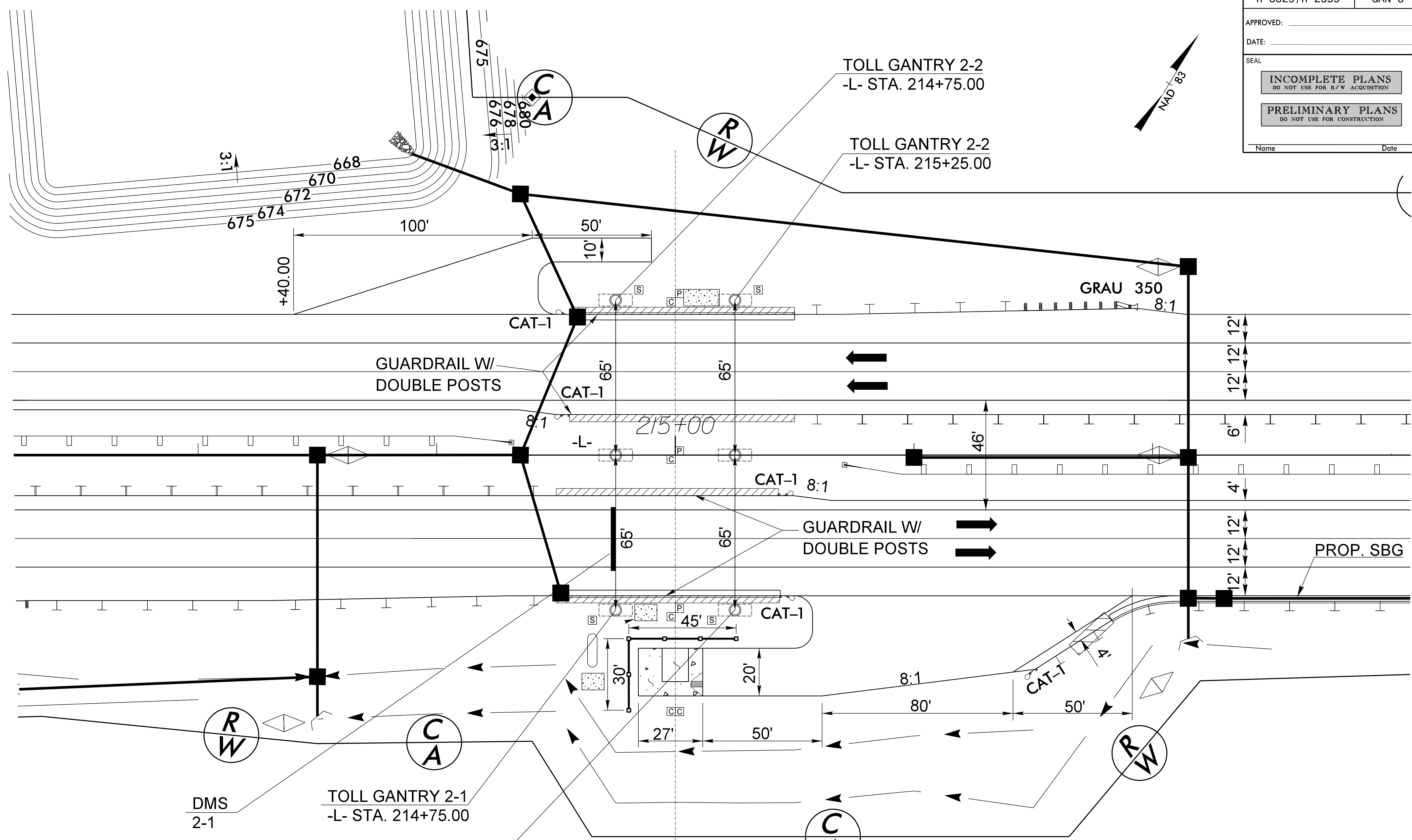

11/17/2015
 R:\Tr-offr\c\Signing\CADD\GANTRY PLANS\plansheets\NR3329_RDY_PSH_AET02 SHEET 03.dgn
 MLH

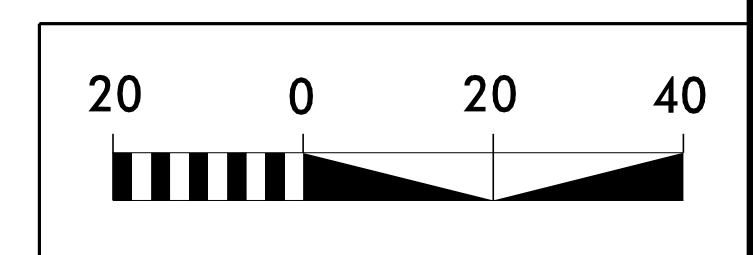

PLANS PREPARED BY :
RK&K
 RUMMEL, KLEPPER & KAHL, LLP
 900 RIDGEFIELD DRIVE SUITE 350
 RALEIGH, NORTH CAROLINA 27609-3960
 NC LICENSE NO. F-0112 (919) 878-9560
 FOR
 THE NORTH CAROLINA
 TURNPIKE AUTHORITY

**TOLL ZONE AND
 GANTRY 2-1 AND 2-2
 DMS 2-1**

TIP NO. R-3329/R-2559	SHEET NO. GAN-4
APPROVED: _____	
DATE: _____	
SEAL	
INCOMPLETE PLANS DO NOT USE FOR R/W ACQUISITION	
PRELIMINARY PLANS DO NOT USE FOR CONSTRUCTION	
Name _____	Date _____

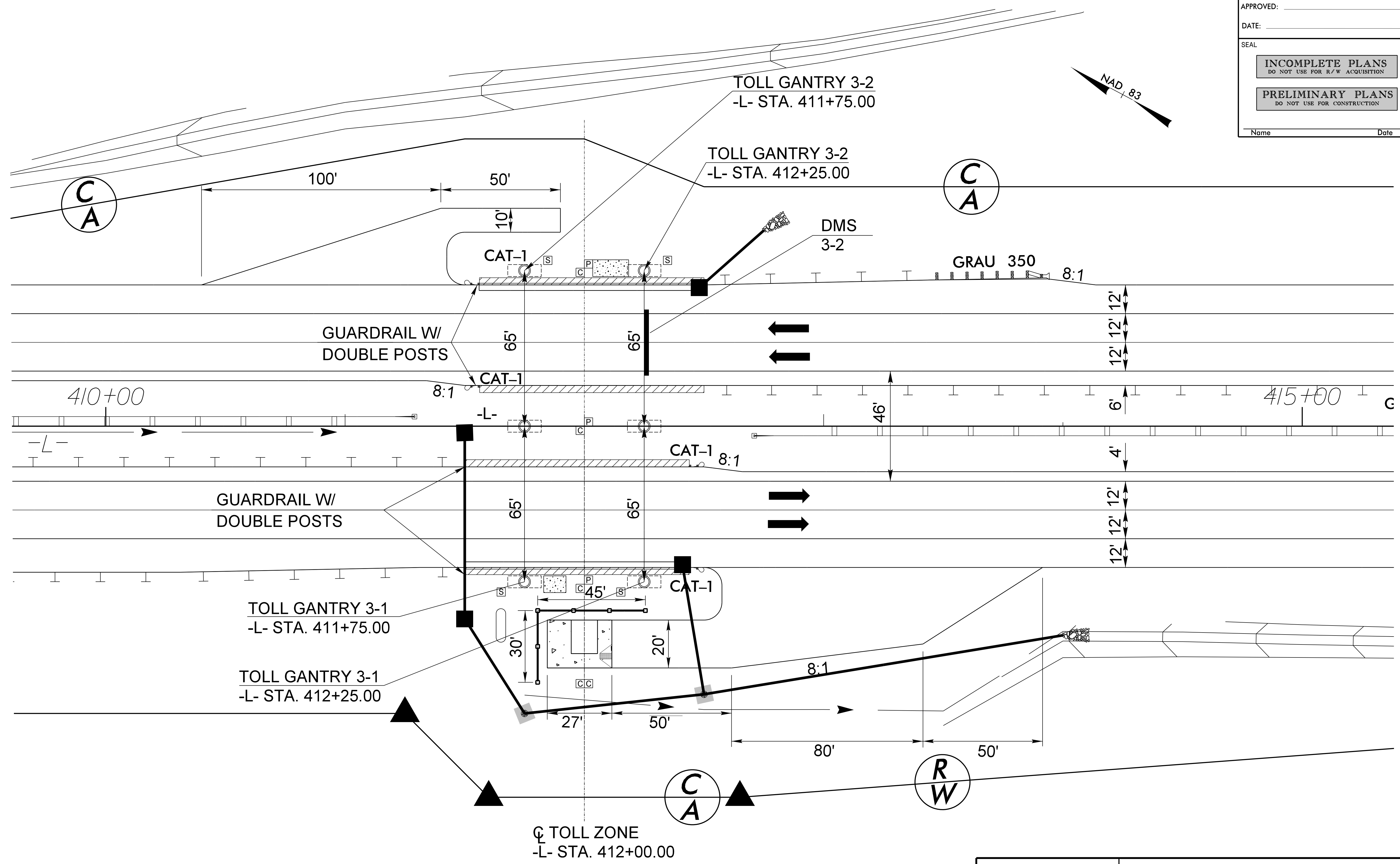

11/17/2015
 R:\T-r\offr\c\Signing\CADD\GANTRY PLANS\plansheets\NR3329_RDY_PSH_AET03 SHEET 04.dgn
 MLH

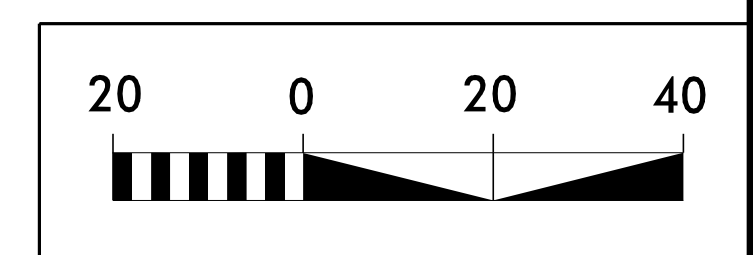

PLANS PREPARED BY :
RK&K
 RUMMEL, KLEPPER & KAHL, LLP
 900 RIDGEFIELD DRIVE SUITE 350
 RALEIGH, NORTH CAROLINA 27609-3960
 NC LICENSE NO. F-0112 (919) 878-9560
 FOR
 THE NORTH CAROLINA
 TURNPIKE AUTHORITY

**TOLL ZONE AND
 GANTRY 3.1 AND 3.2
 DMS 3-2**

TIP NO. R-3329/R-2559	SHEET NO. GAN-5
APPROVED: _____	
DATE: _____	
SEAL	
INCOMPLETE PLANS DO NOT USE FOR R/W ACQUISITION	
PRELIMINARY PLANS DO NOT USE FOR CONSTRUCTION	
Name _____	Date _____

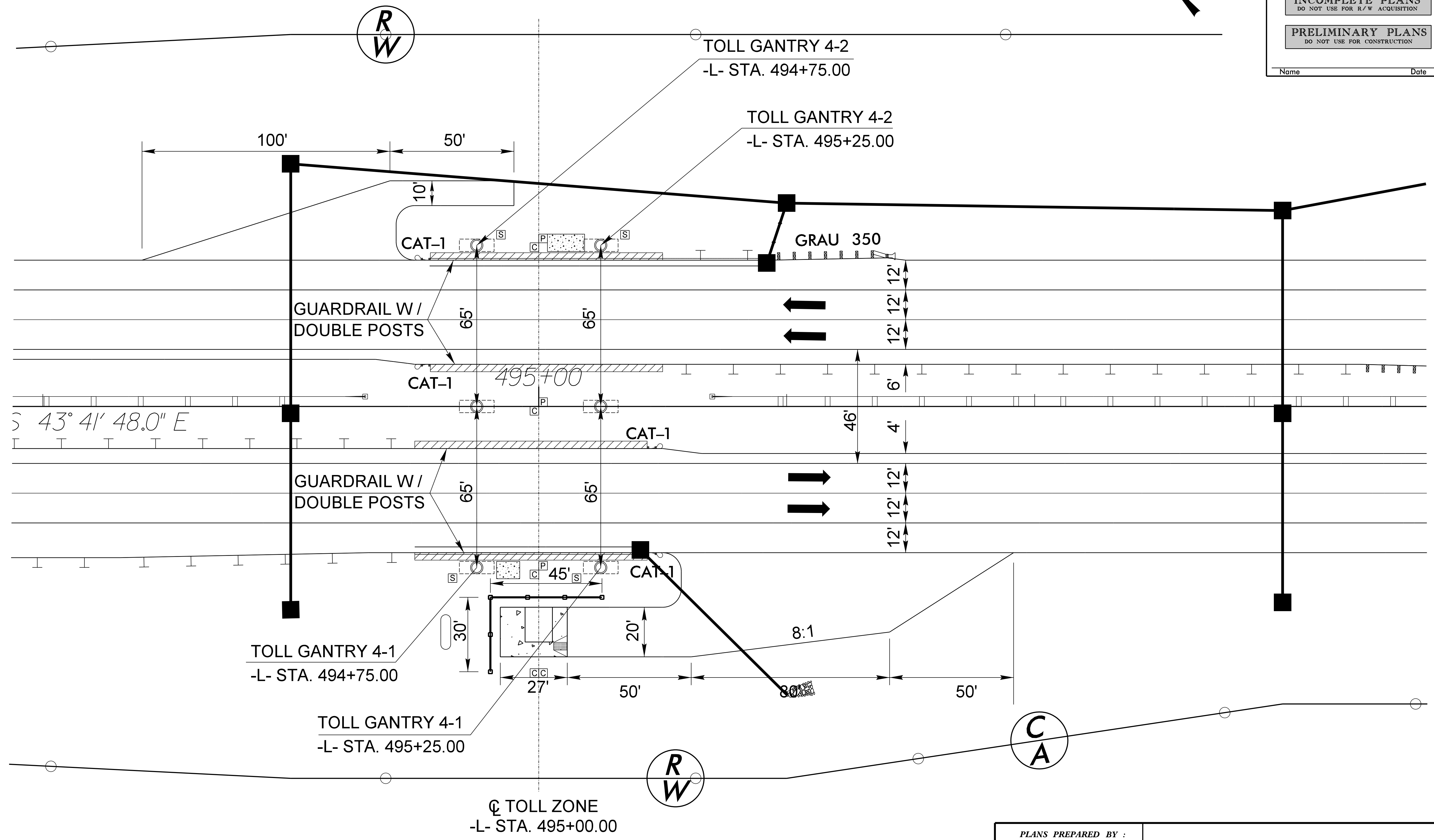
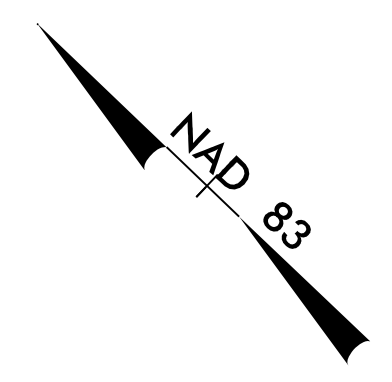

11/17/2015
 R:\T-Office\Signing\CADD\GANTRY PLANS\plansheets\NR3329_RDY_PSH_AET04 SHEET 05.dgn
 MLH

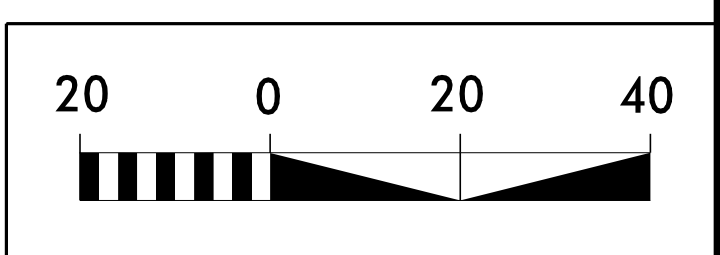

PLANS PREPARED BY :
RK&K
 RUMMEL, KLEPPER & KAHL, LLP
 900 RIDGEFIELD DRIVE SUITE 350
 RALEIGH, NORTH CAROLINA 27609-3960
 NC LICENSE NO. F-0112 (919) 878-9560
 FOR
 THE NORTH CAROLINA
 TURNPIKE AUTHORITY

TOLL ZONE AND GANTRY 4-1 AND 4-2

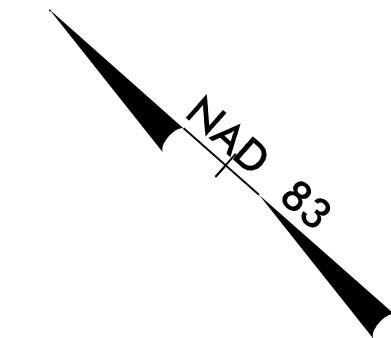
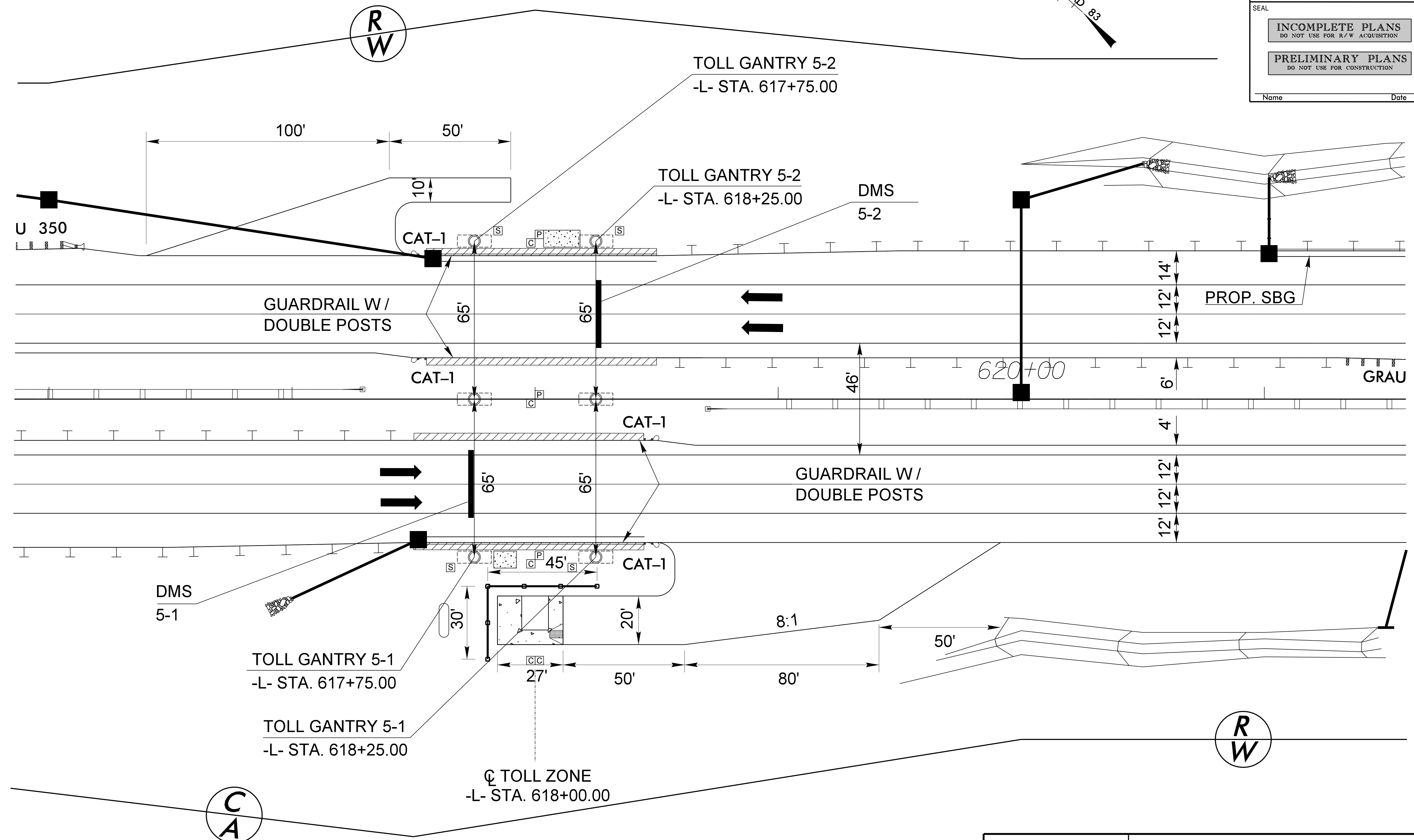

11/17/2015
 R:\T-r\c\Signing\CADD\GANTRY PLANS\plansheets\NR3329_RDY_PSH_AET05 SHEET 06.dgn
 MLH

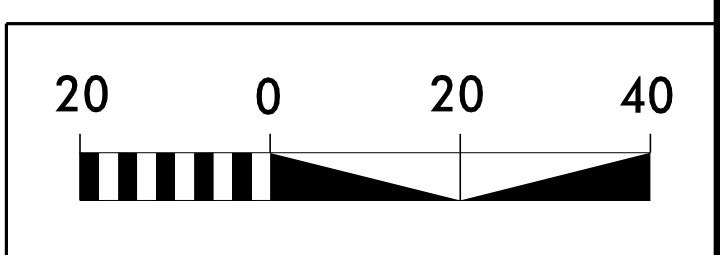

PLANS PREPARED BY :
RK&K
 RUMMEL, KLEPPER & KAHL, LLP
 900 RIDGEFIELD DRIVE SUITE 350
 RALEIGH, NORTH CAROLINA 27609-3960
 NC LICENSE NO. F-0112 (919) 878-9560
 FOR
 THE NORTH CAROLINA
 TURNPIKE AUTHORITY

**TOLL ZONE AND
 GANTRY 5.1 AND 5.2
 DMS 5-1 AND DMS 5-2**

TIP NO. R-3329/R-2559	SHEET NO. GAN-7
APPROVED: _____	
DATE: _____	
SEAL	
INCOMPLETE PLANS DO NOT USE FOR R/W ACQUISITION	
PRELIMINARY PLANS DO NOT USE FOR CONSTRUCTION	
Name _____	Date _____

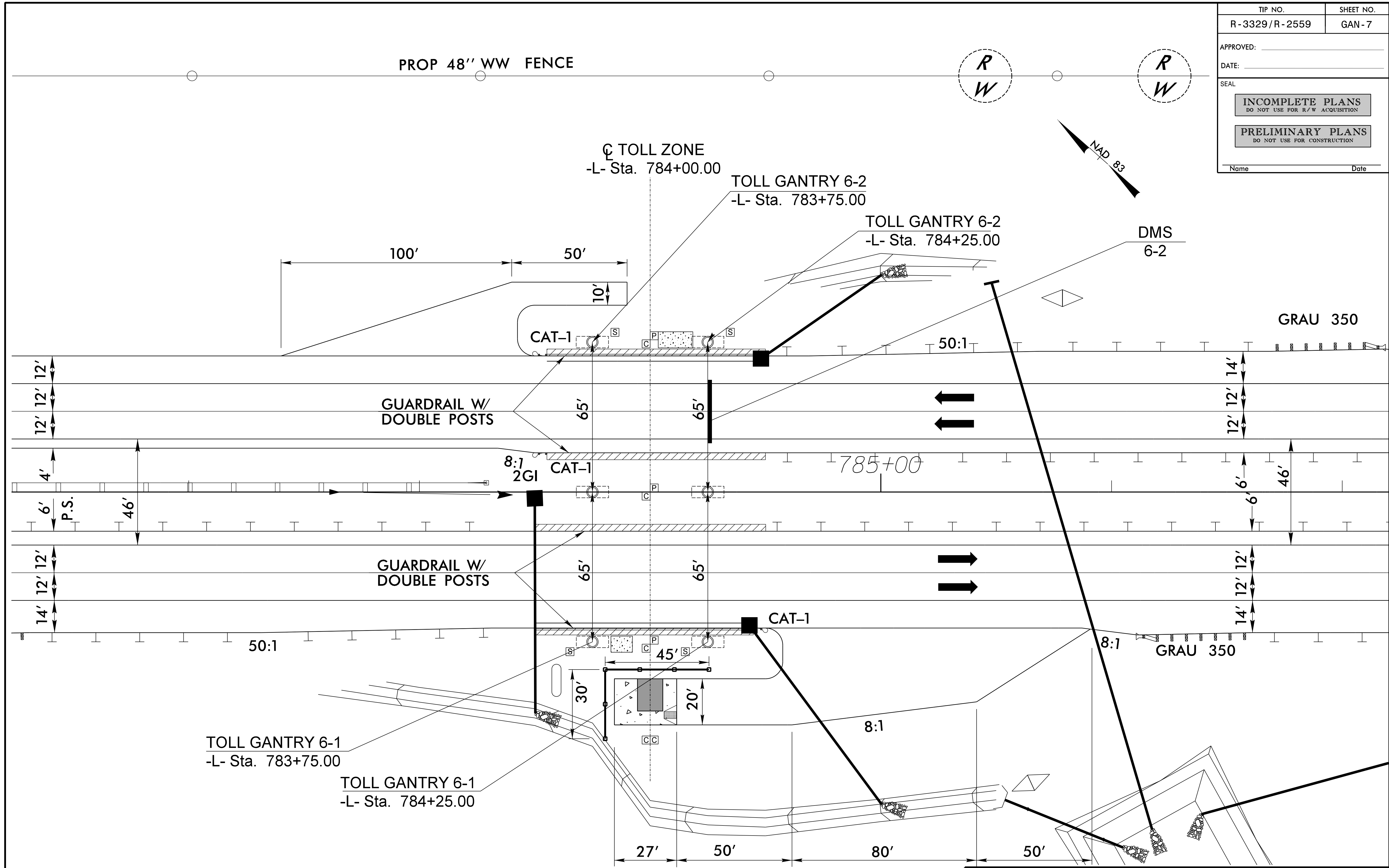

11/17/2015
 R:\T-Offices\Signing\CADD\GANTRY PLANS\plansheets\NR3329_RDY_PSH_AET06 SHEET 07.dgn
 MLH

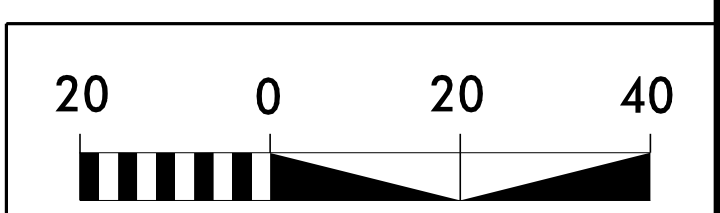

PLANS PREPARED BY :
RK&K
 RUMMEL, KLEPPER & KAHL, LLP
 900 RIDGEFIELD DRIVE SUITE 350
 RALEIGH, NORTH CAROLINA 27609-3960
 NC LICENSE NO. F-0112 (919) 878-9560
 FOR
 THE NORTH CAROLINA
 TURNPIKE AUTHORITY

**TOLL ZONE AND
 GANTRY 6-1 AND 6-2
 DMS 6-2**

TIP NO. R-3329/R-2559	SHEET NO. GAN-8
APPROVED: _____	
DATE: _____	
SEAL	
INCOMPLETE PLANS DO NOT USE FOR R/W ACQUISITION	
PRELIMINARY PLANS DO NOT USE FOR CONSTRUCTION	
Name _____	Date _____

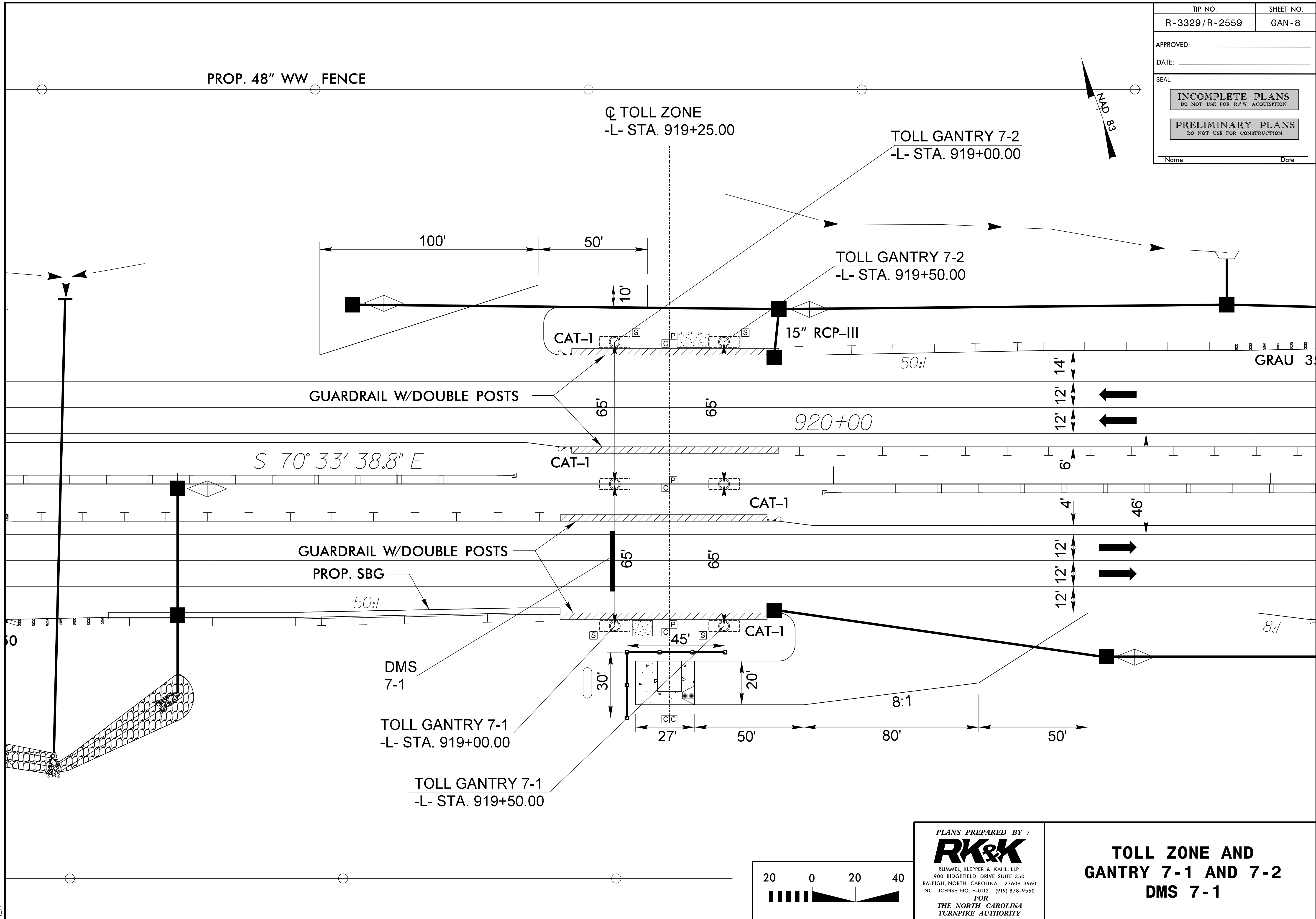
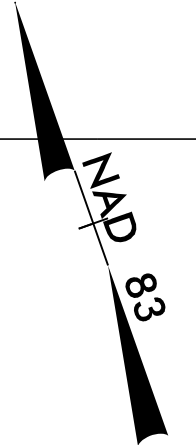

11/17/2015
 R:\T-07\Fic\Signing\CADD\GANTRY PLANS\plansheets\NR3329_RDY_PSH_AET07 SHEET 08.dgn
 MLH

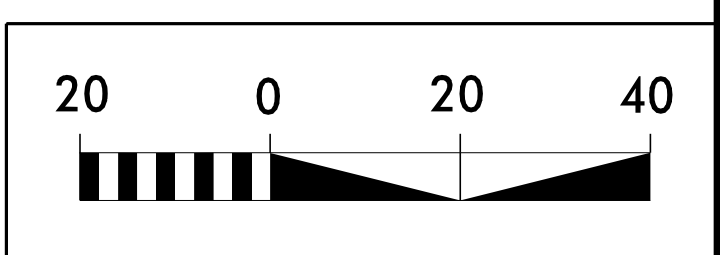

PLANS PREPARED BY :
RK&K
 RUMMEL, KLEPPER & KAHL, LLP
 900 RIDGEFIELD DRIVE SUITE 350
 RALEIGH, NORTH CAROLINA 27609-3960
 NC LICENSE NO. F-0112 (919) 878-9560
 FOR
 THE NORTH CAROLINA
 TURNPIKE AUTHORITY

**TOLL ZONE AND
 GANTRY 7-1 AND 7-2
 DMS 7-1**

TIP NO. R-3329/R-2559	SHEET NO. GAN-9
APPROVED: _____	
DATE: _____	
SEAL	
INCOMPLETE PLANS DO NOT USE FOR R/W ACQUISITION	
PRELIMINARY PLANS DO NOT USE FOR CONSTRUCTION	
Name _____	Date _____

PROP 48" WW FENCE

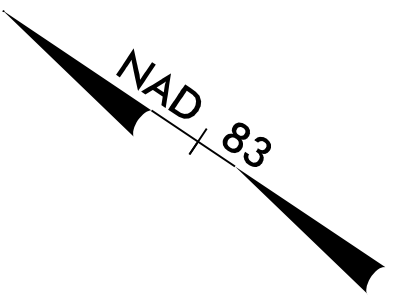
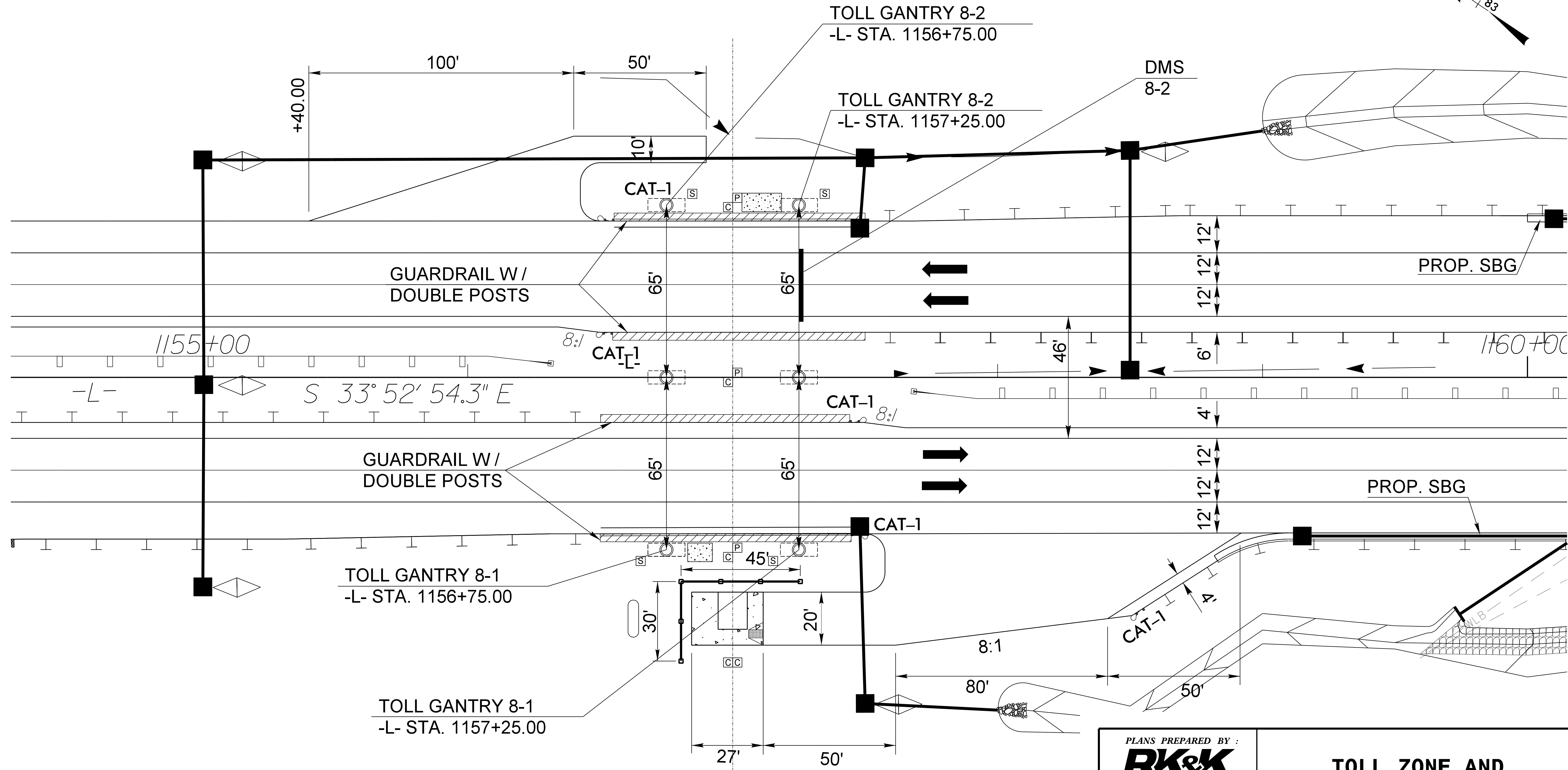

11/17/2015
 R:\T-r\c\Signing\CADD\GANTRY PLANS\plansheets\NR3329_RDY_PSH_AET08 SHEET 09.dgn
 MLH

TOLL ZONE
 -L- STA. 1157+00.00

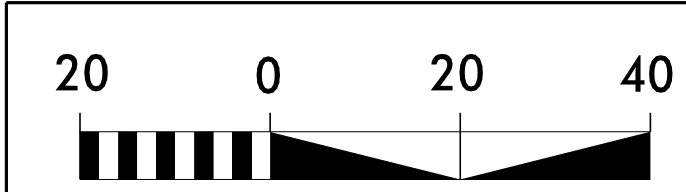

PLANS PREPARED BY:
RK&K
 RUMMEL, KLEPPER & KAHL, LLP
 900 RIDGEFIELD DRIVE SUITE 350
 RALEIGH, NORTH CAROLINA 27609-3960
 NC LICENSE NO. F-0112 (919) 878-9560
 FOR
 THE NORTH CAROLINA
 TURNPIKE AUTHORITY

**TOLL ZONE AND
 GANTRY 8-1 AND 8-2
 DMS 8-2**

TIP NO. R-3329/R-2559	SHEET NO. GAN-11
APPROVED: _____	
DATE: _____	
SEAL	
INCOMPLETE PLANS DO NOT USE FOR R/W ACQUISITION	
PRELIMINARY PLANS DO NOT USE FOR CONSTRUCTION	
Name _____	Date _____

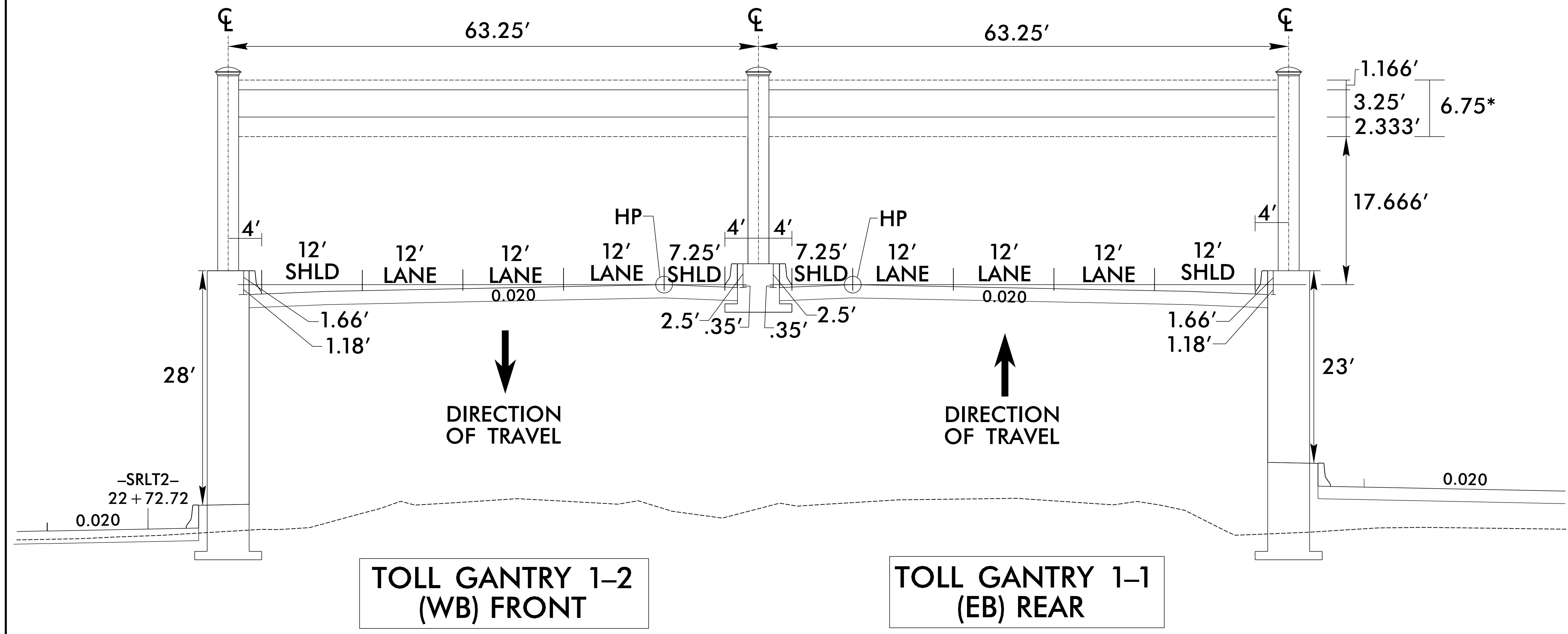

* AESTHETIC CLADDING

PLANS PREPARED BY :
RK&K
 RUMMEL, KLEPPER & KAHL, LLP
 900 RIDGEFIELD DRIVE SUITE 350
 RALEIGH, NORTH CAROLINA 27609-3960
 NC LICENSE NO. F-0112 (919) 878-9560
 FOR
 THE NORTH CAROLINA
 TURNPIKE AUTHORITY

-L-151+40
TOLL ZONE AND
GANTRY 1-1 AND 1-2
BY-PASS US 74

11/17/2015
 R:\T-Offic\Signing\CADD\GANTRY PLANS\plansheets\NR3329_R2559_rdy_xsc.L1.AET-1 SHEET 10 AND 11.dgn
 MLH

TIP NO. R-3329/R-2559	SHEET NO. GAN-12
APPROVED: _____	
DATE: _____	
SEAL	
INCOMPLETE PLANS DO NOT USE FOR R/W ACQUISITION	
PRELIMINARY PLANS DO NOT USE FOR CONSTRUCTION	
Name _____	Date _____

NOTE: DMS 2-1 DIMENSIONS
TO BE DETERMINED AT
A LATER DATE.

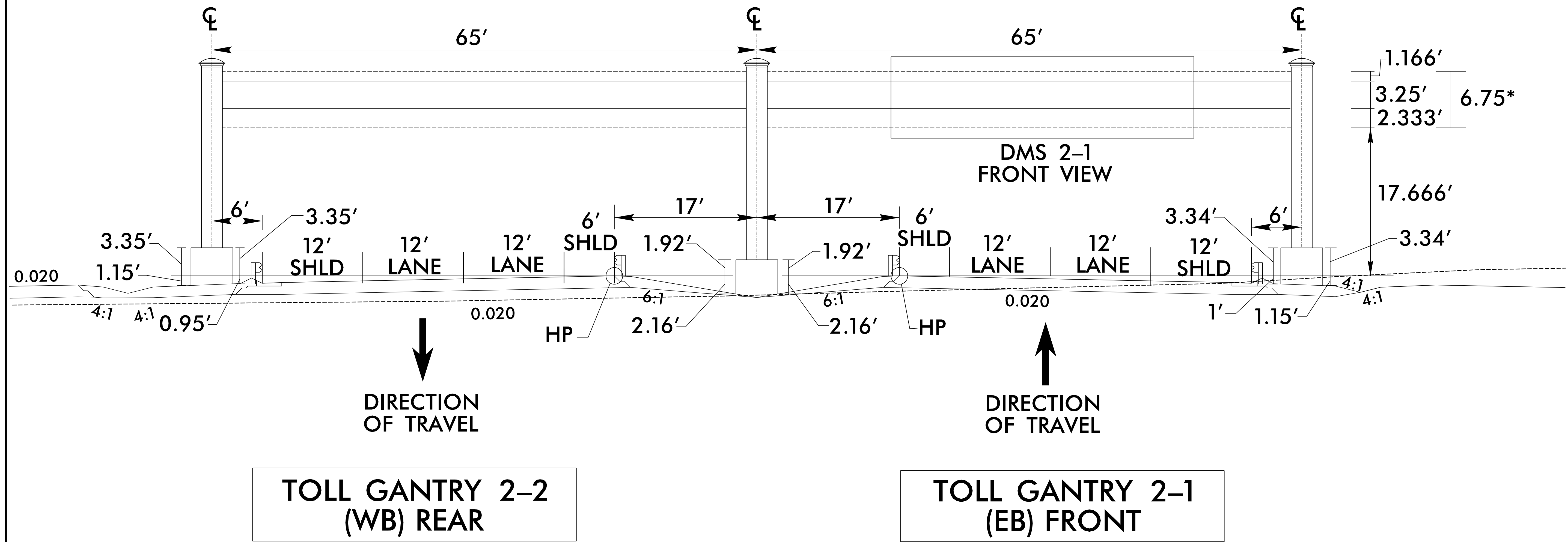

* AESTHETIC CLADDING

**TOLL GANTRY 2-2
(WB) REAR**

**TOLL GANTRY 2-1
(EB) FRONT**

PLANS PREPARED BY :
RK&K
 RUMMEL, KLEPPER & KAHL, LLP
 900 RIDGEFIELD DRIVE SUITE 350
 RALEIGH, NORTH CAROLINA 27609-3960
 NC LICENSE NO. F-0112 (919) 878-9560
 FOR
 THE NORTH CAROLINA
 TURNPIKE AUTHORITY

**-L-214+75
TOLL ZONE AND GANTRY
2-1 AND 2-2 AND DMS 2-1
BY-PASS US 74**

11/17/2015
 R:\T-Offic\Signing\CADD\GANTRY PLANS\plansheets\NR3329_R2559_rdy_xsc.L1.AET-2 SHEET 12 AND 13.dgn
 MLH

TIP NO. R-3329/R-2559	SHEET NO. GAN-14
APPROVED: _____	
DATE: _____	
SEAL	
INCOMPLETE PLANS DO NOT USE FOR R/W ACQUISITION	
PRELIMINARY PLANS DO NOT USE FOR CONSTRUCTION	
Name _____	Date _____

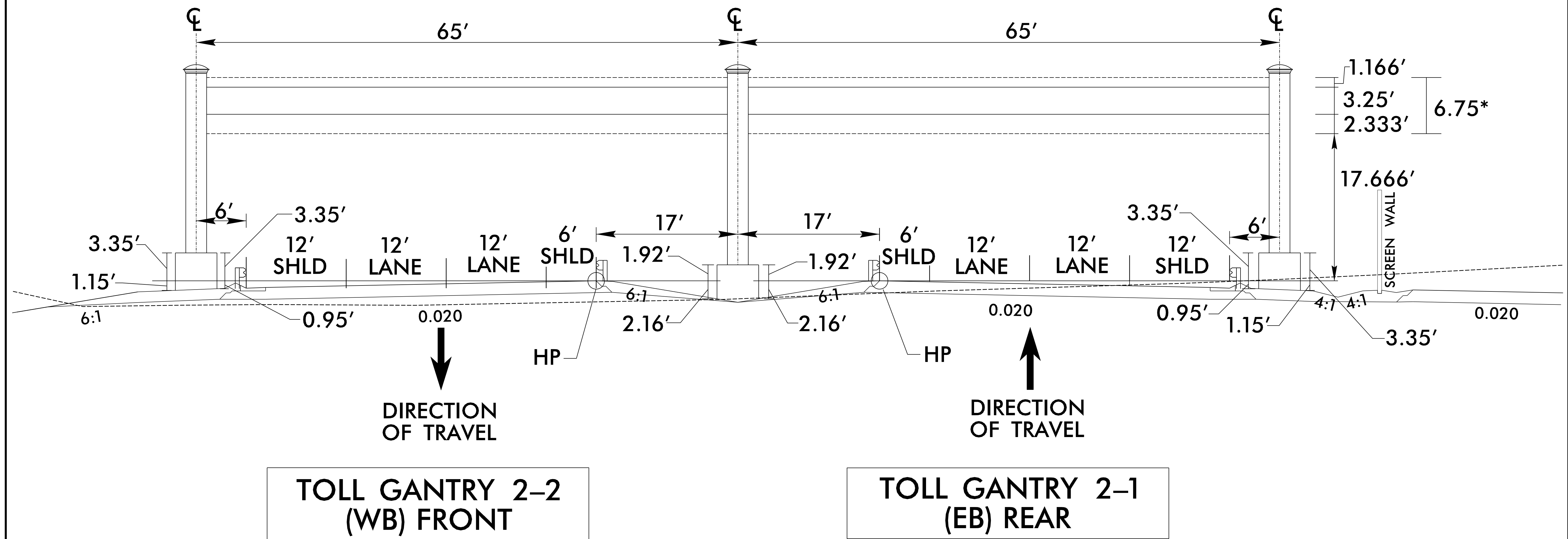

* AESTHETIC CLADDING

PLANS PREPARED BY:
RK&K
 RUMMEL, KLEPPER & KAHL, LLP
 900 RIDGEFIELD DRIVE SUITE 350
 RALEIGH, NORTH CAROLINA 27609-3960
 NC LICENSE NO. F-0112 (919) 878-9560
 FOR
 THE NORTH CAROLINA
 TURNPIKE AUTHORITY

**-L-215+25
 TOLL ZONE AND GANTRY
 2-1 AND 2-2
 BY-PASS US 74**

11/17/2015
 R:\T-Off\c\Signing\CADD\GANTRY PLANS\plansheets\NR3329_R2559_rdy_xsc.L1.AET-2 SHEET 12 AND 13.dgn
 MLH

TIP NO. R-3329/R-2559	SHEET NO. GAN-14
APPROVED: _____	
DATE: _____	
SEAL	
INCOMPLETE PLANS DO NOT USE FOR R/W ACQUISITION	
PRELIMINARY PLANS DO NOT USE FOR CONSTRUCTION	
Name _____	Date _____

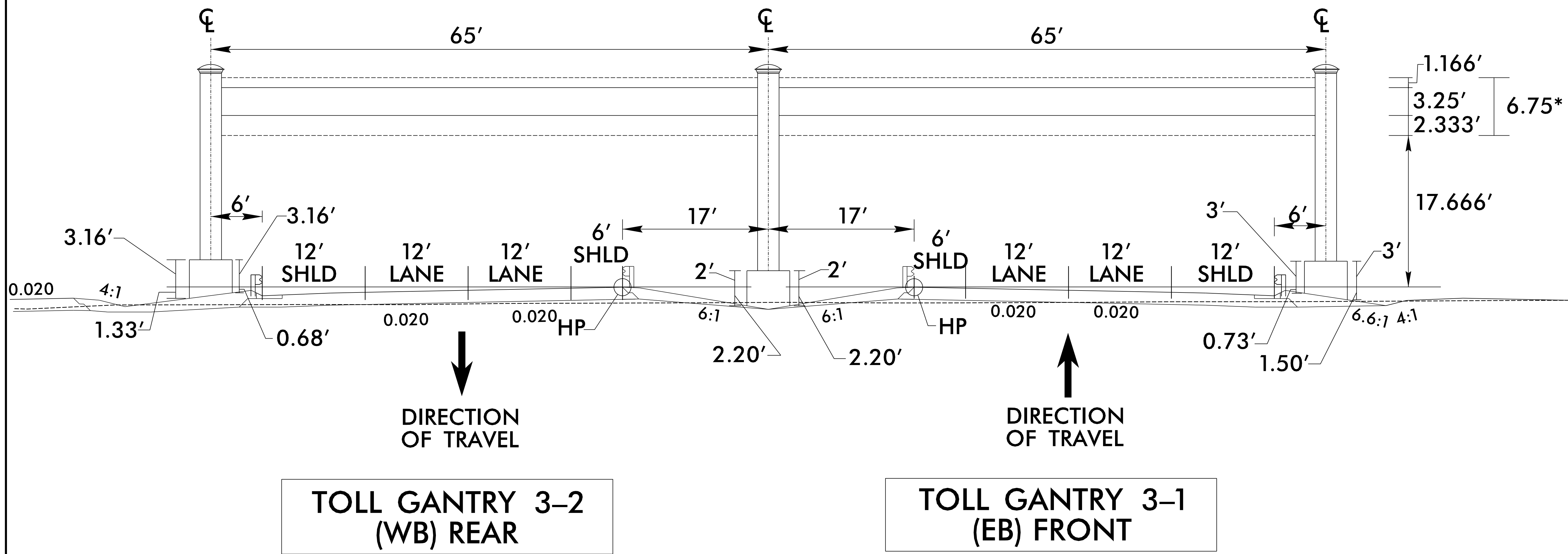

**TOLL GANTRY 3-2
(WB) REAR**

**TOLL GANTRY 3-1
(EB) FRONT**

* AESTHETIC CLADDING

11/17/2015 R:\T-r-off\c\Signing\CADD\GANTRY PLANS\plansheets\NR3329_R2559_rdy_xsc_L2A_AET-3 SHEET 14 AND 15.dgn MLH

PLANS PREPARED BY :
RK&K
 RUMMEL, KLEPPER & KAHL, LLP
 900 RIDGEFIELD DRIVE SUITE 350
 RALEIGH, NORTH CAROLINA 27609-3960
 NC LICENSE NO. F-0112 (919) 878-9560
 FOR
 THE NORTH CAROLINA
 TURNPIKE AUTHORITY

**-L-411+75
TOLL ZONE AND
GANTRY 3-1 AND 3-2
BY-PASS US 74**

TIP NO. R-3329/R-2559	SHEET NO. GAN-15
APPROVED: _____	
DATE: _____	
SEAL	
INCOMPLETE PLANS DO NOT USE FOR R/W ACQUISITION	
PRELIMINARY PLANS DO NOT USE FOR CONSTRUCTION	
Name _____	Date _____

NOTE: DMS 3-2 DIMENSIONS TO BE DETERMINED AT A LATER DATE.

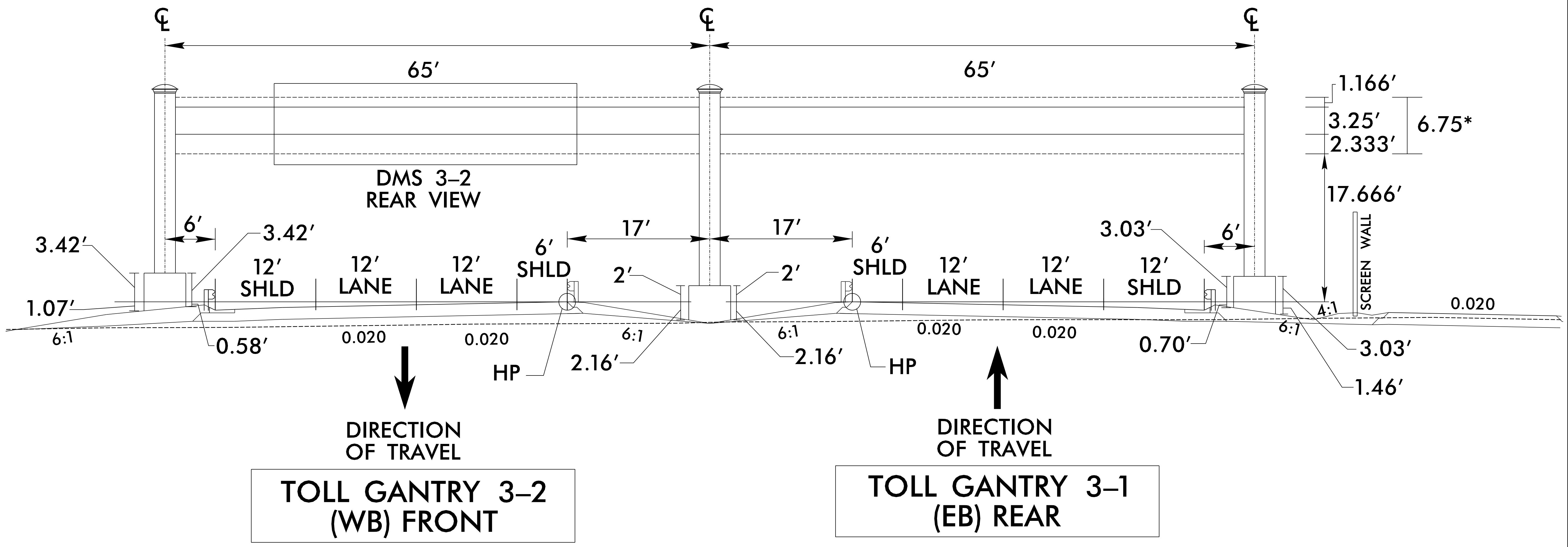

* AESTHETIC CLADDING

11/17/2015 R:\T-r-offr\c\Signing\CADD\GANTRY PLANS\plansheets\NR3329_R2559_rdy_xsc_L2A_AET-3 SHEET 14 AND 15.dgn MLH

<p>PLANS PREPARED BY :</p> <p>RK&K</p> <p>RUMMEL, KLEPPER & KAHL, LLP 900 RIDGEFIELD DRIVE SUITE 350 RALEIGH, NORTH CAROLINA 27609-3960 NC LICENSE NO. F-0112 (919) 878-9560</p> <p>FOR THE NORTH CAROLINA TURNPIKE AUTHORITY</p>	<p style="text-align: center;">-L-412+25 TOLL ZONE AND GANTRY 3-1 AND 3-2 AND DMS 3-2 BY-PASS US 74</p>
--	---

TIP NO. R-3329/R-2559	SHEET NO. GAN-16
APPROVED: _____	
DATE: _____	
SEAL	
INCOMPLETE PLANS DO NOT USE FOR R/W ACQUISITION	
PRELIMINARY PLANS DO NOT USE FOR CONSTRUCTION	
Name _____	Date _____

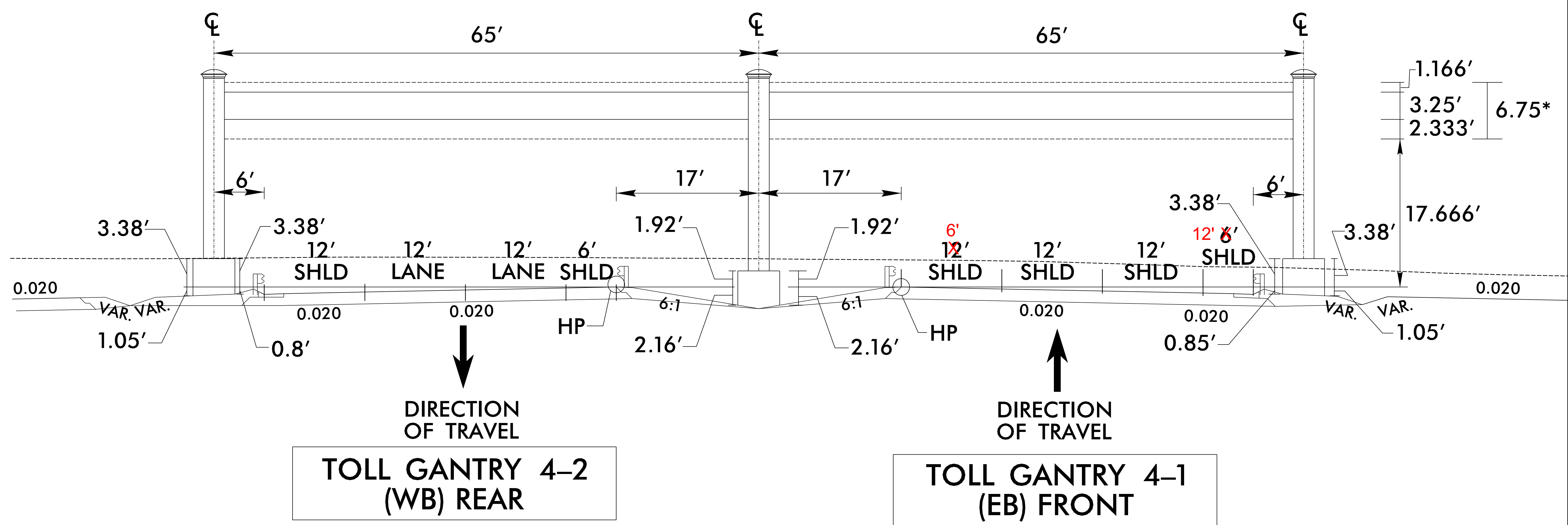

* AESTHETIC CLADDING

11/17/2015
 R:\T-r-offr\c\Signing\CADD\GANTRY PLANS\plansheets\NR3329_r2559_rdy_xsc_L2B_AET-4 SHEET 16 AND 17.dgn
 MLH

PLANS PREPARED BY :
RK&K
 RUMMEL, KLEPPER & KAHL, LLP
 900 RIDGFIELD DRIVE SUITE 350
 RALEIGH, NORTH CAROLINA 27609-3960
 NC LICENSE NO. F-0112 (919) 878-9560
 FOR
 THE NORTH CAROLINA
 TURNPIKE AUTHORITY

-L-494+75
TOLL ZONE AND
GANTRY 4-1 AND 4-2
BY-PASS US 74

TIP NO. R-3329/R-2559	SHEET NO. GAN-17
APPROVED: _____	
DATE: _____	
SEAL	
INCOMPLETE PLANS DO NOT USE FOR R/W ACQUISITION	
PRELIMINARY PLANS DO NOT USE FOR CONSTRUCTION	
Name _____	Date _____

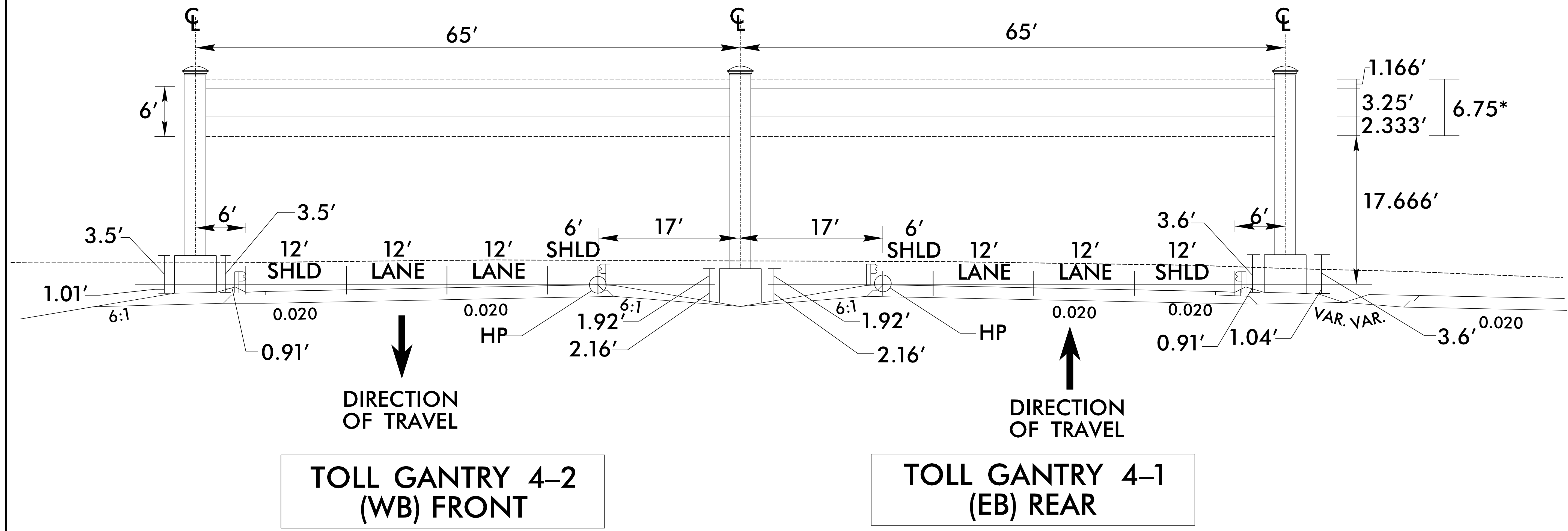

* AESTHETIC CLADDING

PLANS PREPARED BY :
RK&K
 RUMMEL, KLEPPER & KAHL, LLP
 900 RIDGEFIELD DRIVE SUITE 350
 RALEIGH, NORTH CAROLINA 27609-3960
 NC LICENSE NO. F-0112 (919) 878-9560
 FOR
 THE NORTH CAROLINA
 TURNPIKE AUTHORITY

**-L-495+25
 TOLL ZONE AND
 GANTRY 4-1 AND 4-2
 BY-PASS US 74**

11/17/2015 R:\T-Offic\Signing\CADD\GANTRY PLANS\plansheets\NR3329_R2559_rdy_xsc_L2B_AET-4 SHEET 16 AND 17.dgn MLH

NOTE: DMS 5-1 DIMENSIONS
TO BE DETERMINED AT
A LATER DATE.

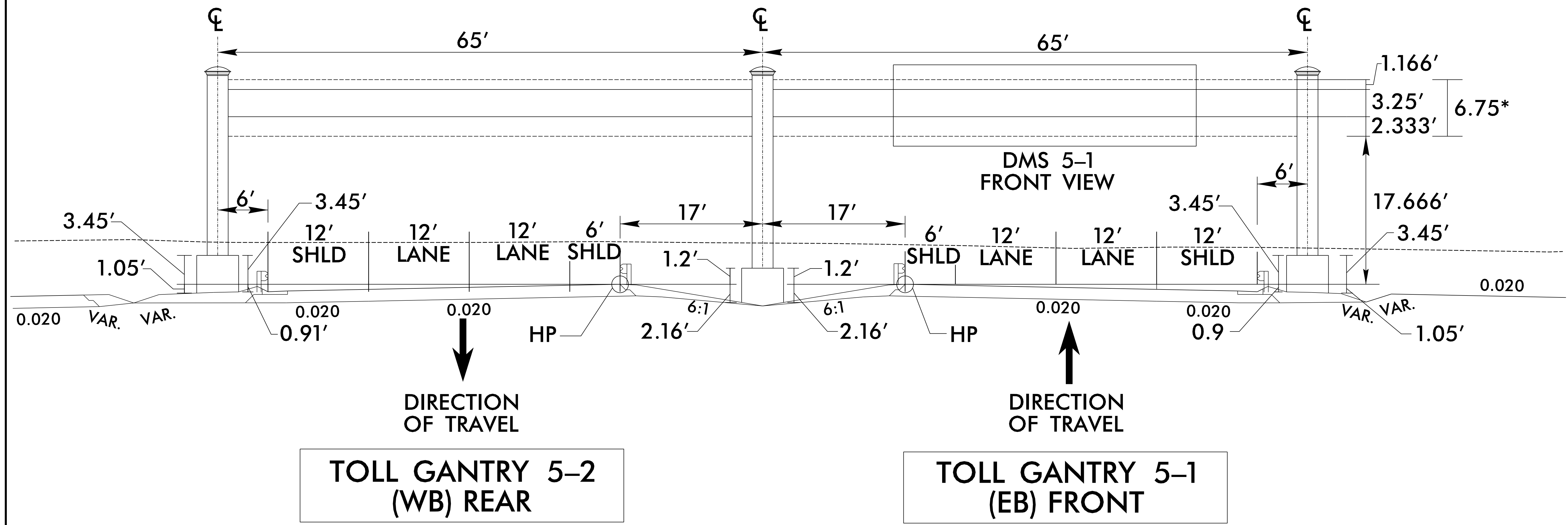

* AESTHETIC CLADDING

11/17/2015 R:\T-r\off\c\Signing\CADD\GANTRY PLANS\plansheets\NR3329_R2559_rdy_xsc_L2B_AET-5 SHEET 18 AND 19.dgn MLH

PLANS PREPARED BY :
RK&K
 RUMMEL, KLEPPER & KAHL, LLP
 900 RIDGEFIELD DRIVE SUITE 350
 RALEIGH, NORTH CAROLINA 27609-3960
 NC LICENSE NO. F-0112 (919) 878-9560
 FOR
 THE NORTH CAROLINA
 TURNPIKE AUTHORITY

-L-617+75
TOLL ZONE AND GANTRY
5-1 AND 5-2 AND DMS 5-1
BY-PASS US 74

NOTE: DMS 5-2 DIMENSIONS TO BE DETERMINED AT A LATER DATE.

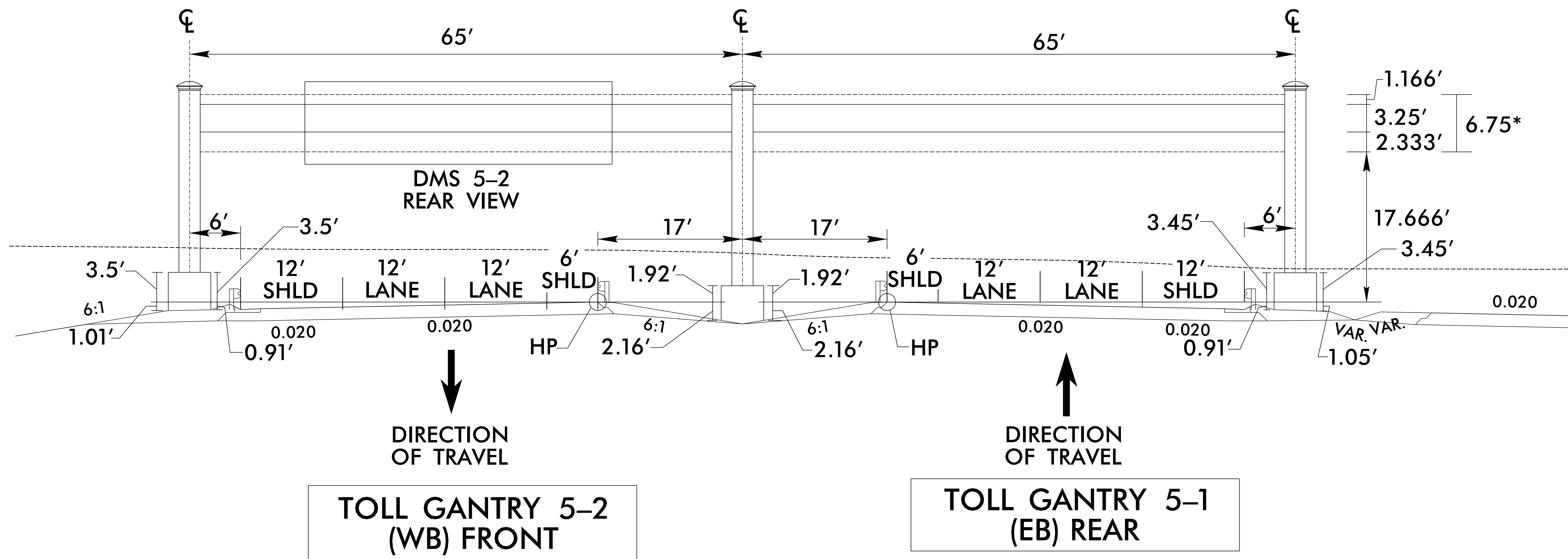

* AESTHETIC CLADDING

11/17/2015 R:\T-Offices\Signing\CADD\GANTRY PLANS\plansheets\NR3329_R2559_rdy_xsc_L2B_AET-5 SHEET 18 AND 19.dgn MLH

PLANS PREPARED BY : RK&K <small>RUMMEL, KLEPPER & KAHL, LLP 900 RIDGEFIELD DRIVE SUITE 350 RALEIGH, NORTH CAROLINA 27609-3960 NC LICENSE NO. F-0112 (919) 878-9560</small> FOR THE NORTH CAROLINA TURNPIKE AUTHORITY	-L-618+25 TOLL ZONE AND GANTRY 5-1 AND 5-2 AND DMS 5-2 BY-PASS US 74
--	--

TIP NO. R-3329/R-2559	SHEET NO. GAN-20
APPROVED: _____	
DATE: _____	
SEAL	
INCOMPLETE PLANS DO NOT USE FOR R/W ACQUISITION	
PRELIMINARY PLANS DO NOT USE FOR CONSTRUCTION	
Name _____	Date _____

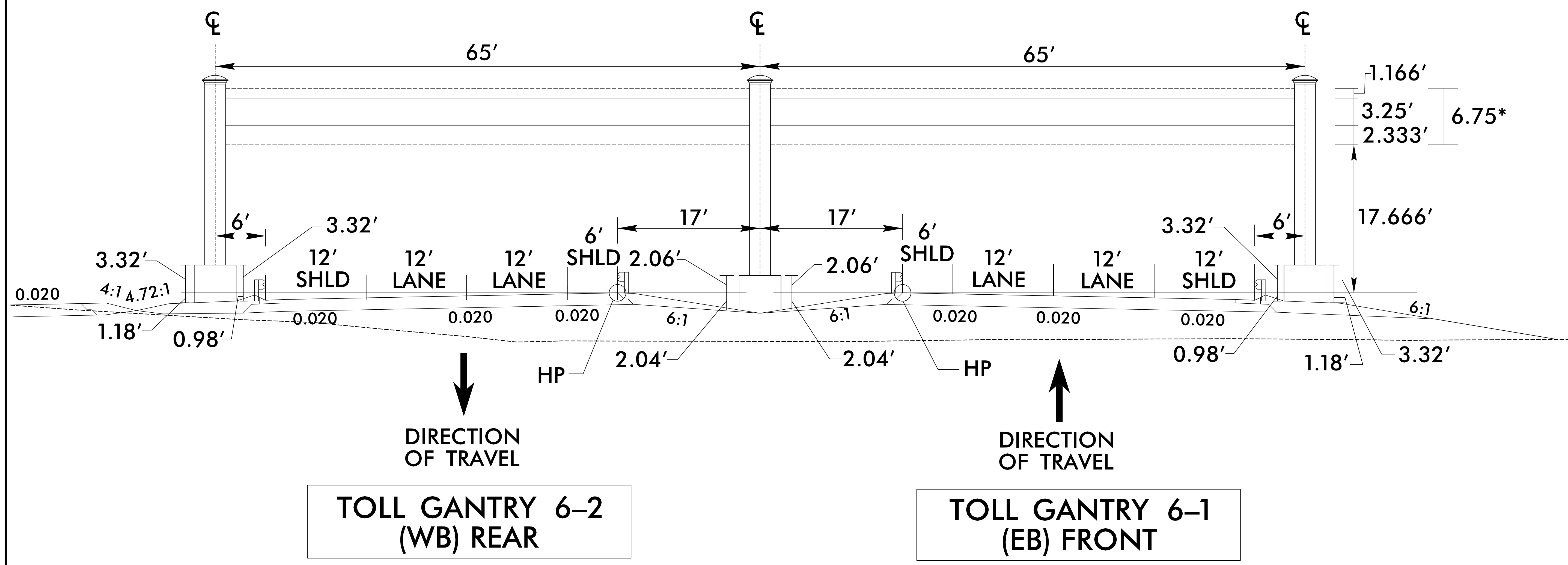

* AESTHETIC CLADDING

11/17/2015
 R:\T-Office\Signing\CADD\GANTRY PLANS\plansheets\NR3329_RDY_xsc.L2C.AET-6 SHEET 20 AND 21.dgn
 MLH

PLANS PREPARED BY :
RK&K
 RUMMEL, KLEPPER & KAHL, LLP
 900 RIDGEFIELD DRIVE SUITE 350
 RALEIGH, NORTH CAROLINA 27609-3960
 NC LICENSE NO. F-0112 (919) 878-9560
 FOR
 THE NORTH CAROLINA
 TURNPIKE AUTHORITY

-L-783+75
TOLL ZONE AND
GANTRY 6-1 AND 6-2
BY-PASS US 74

NOTE: DMS 6-2 DIMENSIONS TO BE DETERMINED AT A LATER DATE.

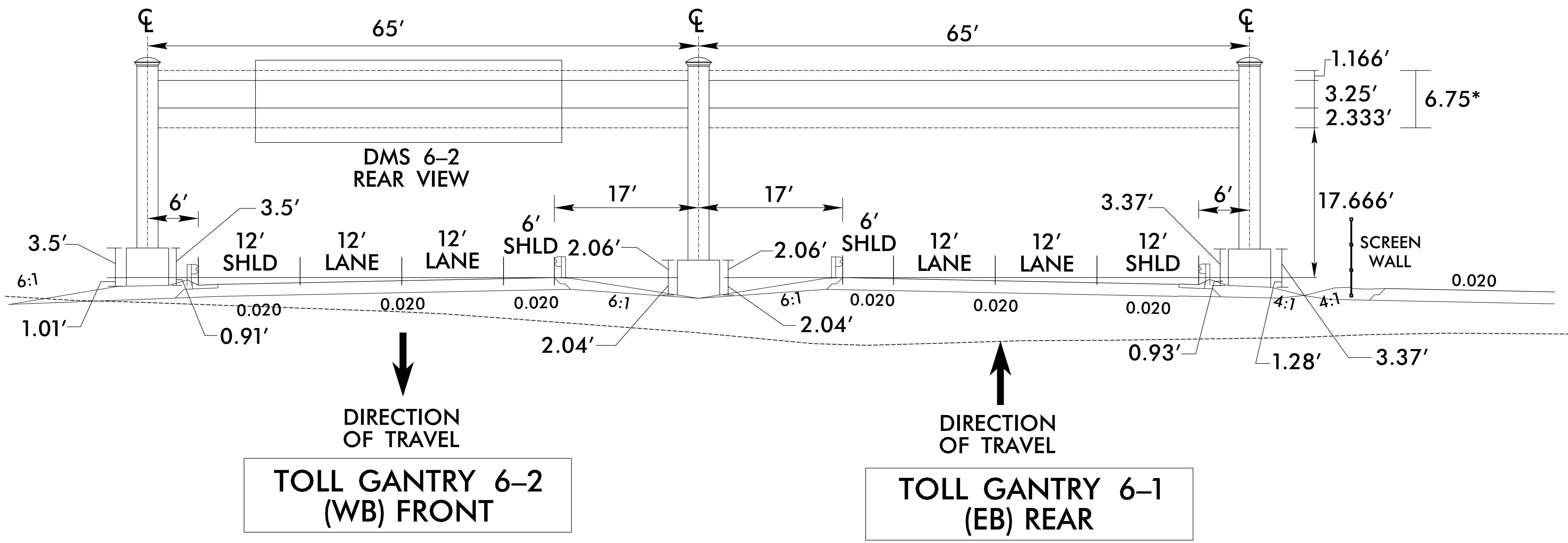

* AESTHETIC CLADDING

11/17/2015 R:\Tr-offr\c\Signing\CADD\GANTRY PLANS\plansheets\NR3329_RDY_xsc.L2C.AET-6 SHEET 20 AND 21.dgn MLH

PLANS PREPARED BY:
RK&K
 RUMMEL, KLEPPER & KAHL, LLP
 900 RIDGEFIELD DRIVE SUITE 350
 RALEIGH, NORTH CAROLINA 27609-3960
 NC LICENSE NO. F-0112 (919) 878-9560
 FOR
 THE NORTH CAROLINA
 TURNPIKE AUTHORITY

-L-784+25
**TOLL ZONE AND GANTRY
 6-1 AND 6-2 AND DMS 6-2
 BY-PASS US 74**

NOTE: DMS 7-1 DIMENSIONS TO BE DETERMINED AT A LATER DATE.

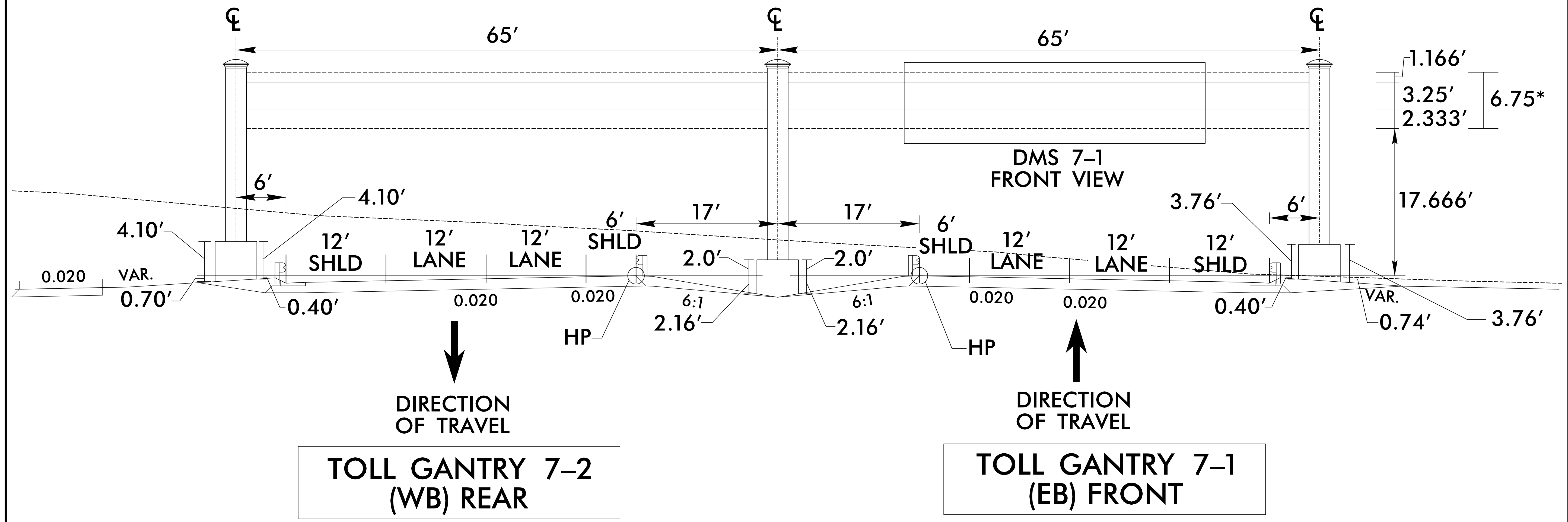

* AESTHETIC CLADDING

11/17/2015 R:\T-r\Fric\Signing\CADD\GANTRY PLANS\plansheets\NR3329_R2559_rdy_xsc_L3A_AET-7 SHEET 22 AND 23.dgn MLH

PLANS PREPARED BY :
RK&K
 RUMMEL, KLEPPER & KAHL, LLP
 900 RIDGEFIELD DRIVE SUITE 350
 RALEIGH, NORTH CAROLINA 27609-3960
 NC LICENSE NO. F-0112 (919) 878-9560
 FOR
 THE NORTH CAROLINA
 TURNPIKE AUTHORITY

-L-919+00
TOLL ZONE AND GANTRY
7-1 AND 7-2 AND DMS 7-1
BY-PASS US 74

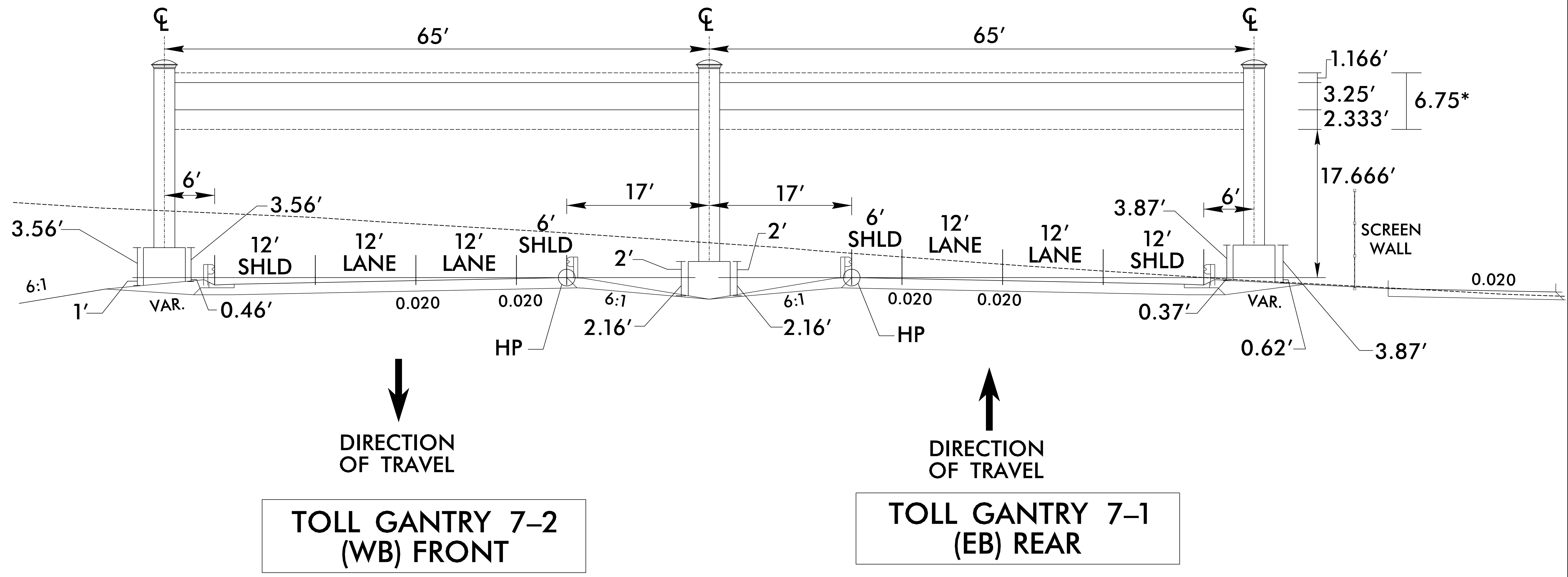

TIP NO. R-3329/R-2559	SHEET NO. GAN-24
APPROVED: _____	
DATE: _____	
SEAL	
INCOMPLETE PLANS DO NOT USE FOR R/W ACQUISITION	
PRELIMINARY PLANS DO NOT USE FOR CONSTRUCTION	
Name _____	Date _____

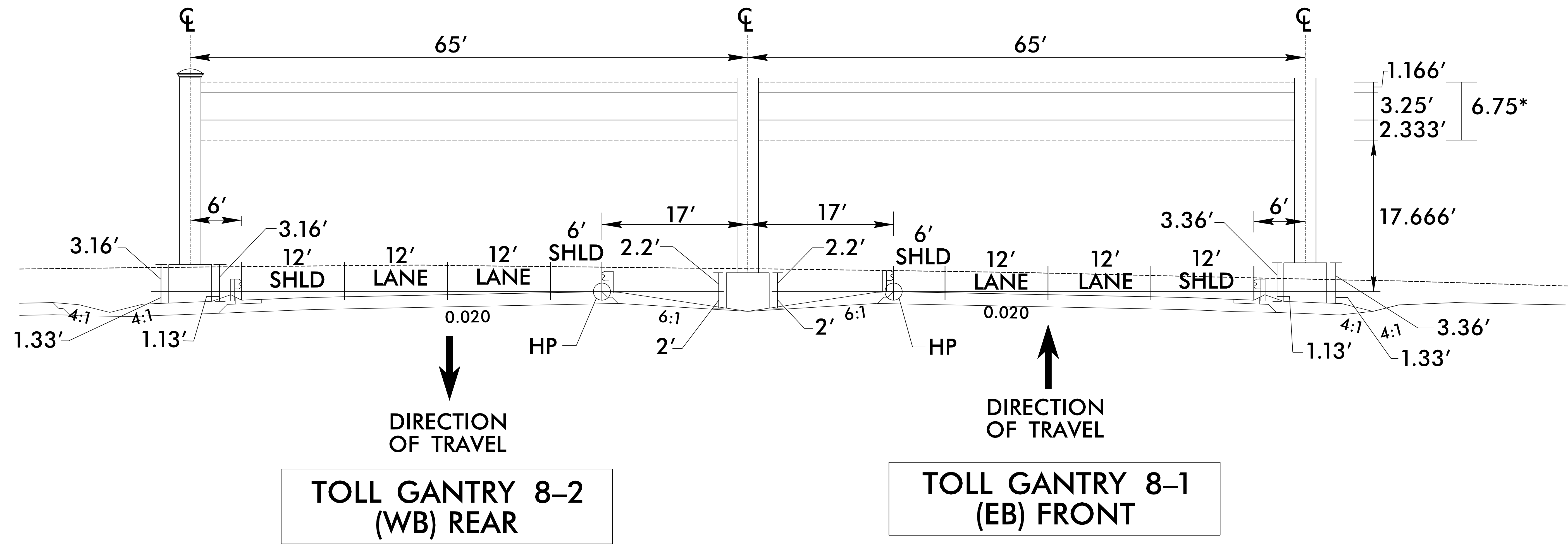

* AESTHETIC CLADDING

11/17/2015
 R:\T-Offic\Signing\CADD\GANTRY PLANS\plansheets\NR3329_R2559_rdy_xsc_L3B_AET-8 SHEET 24 AND 25.dgn
 MLH

PLANS PREPARED BY :
RK&K
 RUMMEL, KLEPPER & KAHL, LLP
 900 RIDGEFIELD DRIVE SUITE 350
 RALEIGH, NORTH CAROLINA 27609-3960
 NC LICENSE NO. F-0112 (919) 878-9560
 FOR
 THE NORTH CAROLINA
 TURNPIKE AUTHORITY

-L-1156+00
TOLL ZONE AND
GANTRY 8-1 AND 8-2
BY-PASS US 74

NOTE: DMS 8-2 DIMENSIONS TO BE DETERMINED AT A LATER DATE.

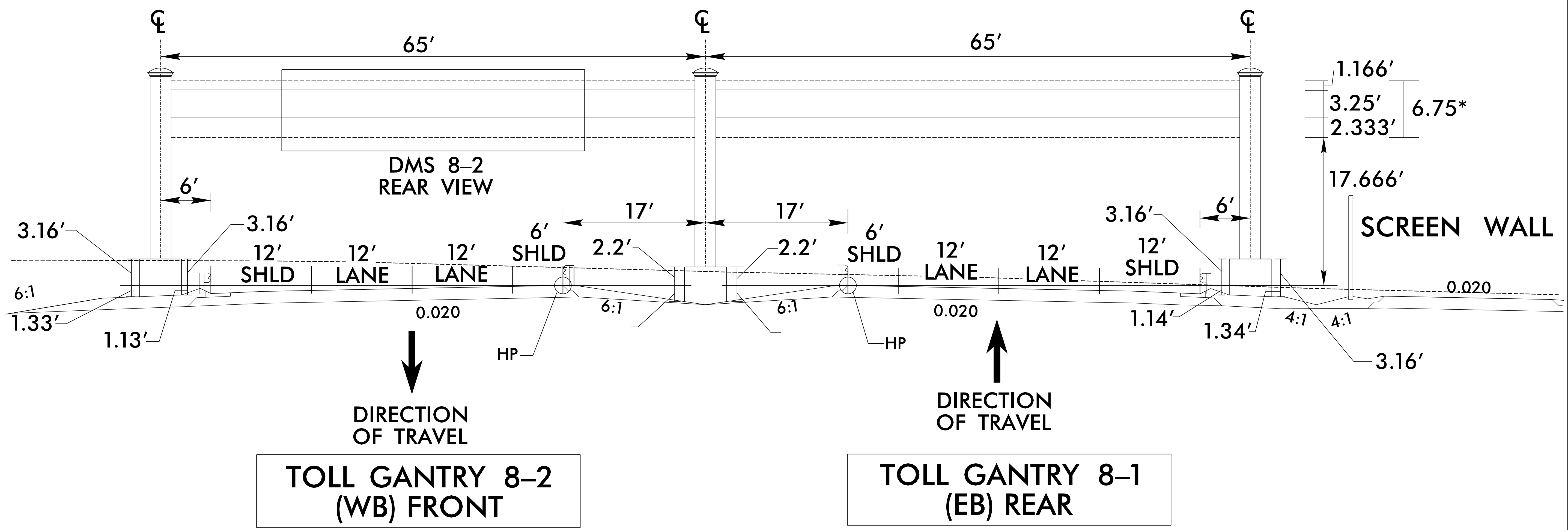

* AESTHETIC CLADDING

11/17/2015 R:\T-Off\c\Signing\CADD\GANTRY PLANS\plansheets\NR3329_R2559_rdy_xsc_L3B_AET-8 SHEET 24 AND 25.dgn MLH

<p>PLANS PREPARED BY :</p> <p>RK&K</p> <p>RUMMEL, KLEPPER & KAHL, LLP 900 RIDGEFIELD DRIVE SUITE 350 RALEIGH, NORTH CAROLINA 27609-3960 NC LICENSE NO. F-0112 (919) 878-9560</p> <p>FOR THE NORTH CAROLINA TURNPIKE AUTHORITY</p>	<p>-L-1157+00</p> <p>TOLL ZONE AND GANTRY</p> <p>8-1 AND 8-2 AND DMS 8-2</p> <p>BY-PASS US 74</p>
--	---