

ALAMANCE COUNTY

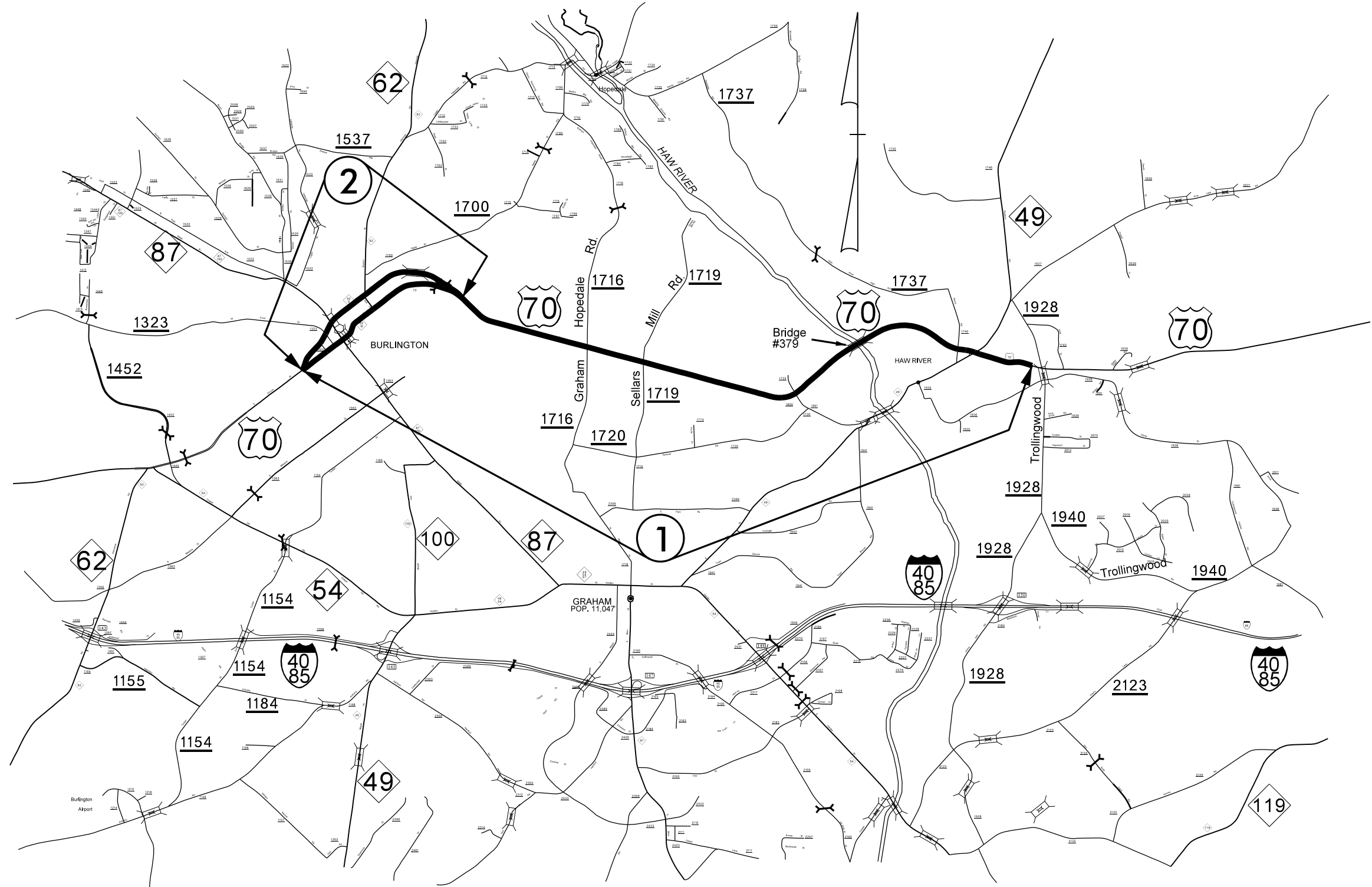

24-JAN-2019 07:25
S:\DDC\Resur\proj\2020 PO Contracts\Alamance\2020CPT.07.07.10011\CADD\2020CPT.07.07.10011.vicrmi.txdgn
Alamance County, NC
11/10/2019

STATE	PROJECT NO.	SHEET NO.	TOTAL SHEETS
N.C.	2020CPT.07.07.10011	2	8

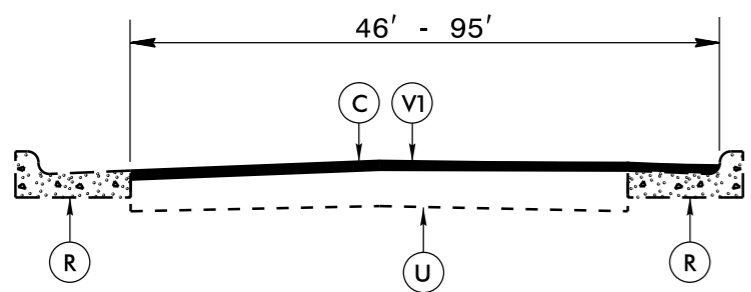

TYPICAL SECTION NO. 1
TO BE USED ON MAP 1
MAP 1: STA. 0+00 TO STA. 2+35

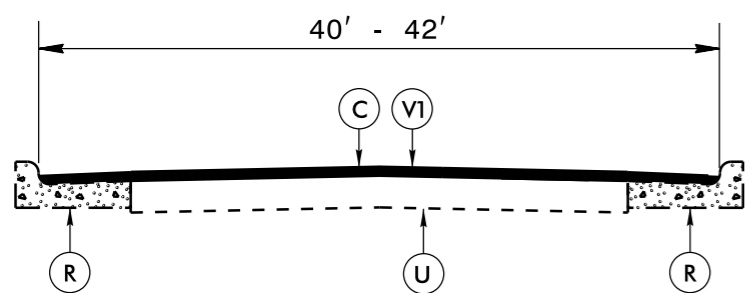

TYPICAL SECTION NO. 2
TO BE USED ON MAP 1
MAP 1: STA. 2+35 TO STA. 47+55

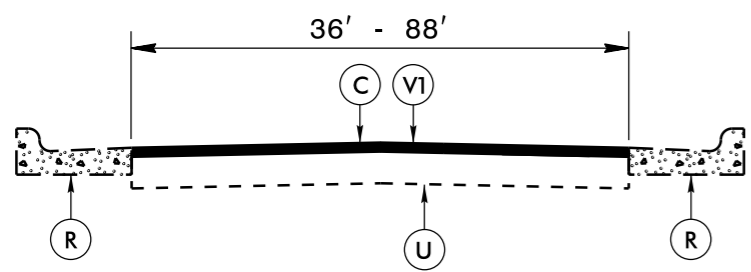

TYPICAL SECTION NO. 3
TO BE USED ON MAPS 1, 2
MAP 1: STA. 47+55 TO STA. 122+00
STA. 122+00 TO STA. 133+43 (Skip U-5843)
STA. 133+43 TO STA. 207+58
MAP 2: STA. 00+00 TO STA. 75+41

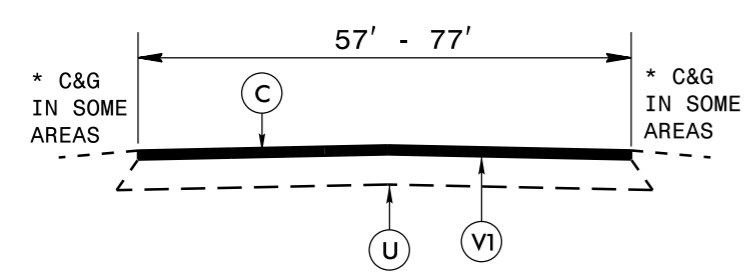

TYPICAL SECTION NO. 4
TO BE USED ON MAP 1
MAP 1: STA. 207+58 TO STA. 306+78

STANDARD CONCRETE ENCASEMENT FOR VALVE CASTINGS IN PAVEMENT

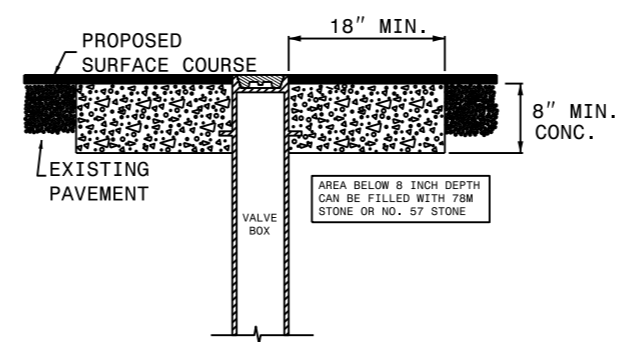

USE RAPID SET GROUT, MORTAR, OR CONCRETE CLASS B CONCRETE MAY BE USED WHEN ADJUSTMENTS ARE NOT IN THE TRAVEL LANE.

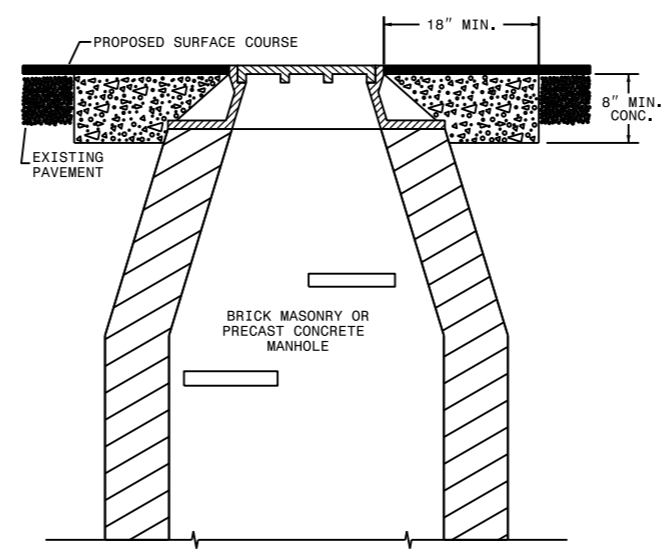

- NOTES:
1. MORTAR SHALL BE MIXED TO NCDOT SPECIFICATIONS.
 2. ALL FAULTY EXISTING BRICKWORK TO BE REMOVED AND REPLACED WITH NEW BRICK MASONRY.
 3. EXCAVATION FOR THE ADJUSTMENT SHALL BE SHEER CUT ON ALL SIDES.
 4. RAPID SET GROUT, MORTAR, OR CONCRETE SHALL BE USED

PATCHING EXISTING PAVEMENT DETAIL 1

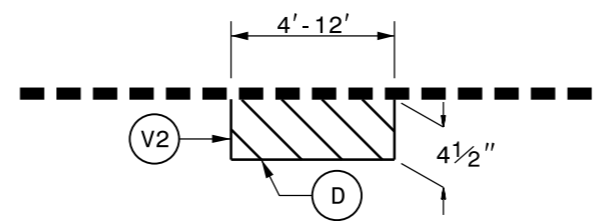

MILL EXISTING ASPHALT PAVEMENT 4 1/2" IN DEPTH AND FILL WITH INTERMEDIATE COURSE, TYPE I19.0C AT LOCATIONS AS DIRECTED BY THE ENGINEER.
TO BE USED IN CONJUNCTION WITH MAPS ____

4 1/2" MILLING = __ SYD
INTERMEDIATE COURSE, TYPE I19.0C = __ TONS

PAVEMENT SCHEDULE

C	PROP. APPROX. 1 1/2" ASPHALT CONCRETE SURFACE COURSE, TYPE S9.5C, AT AN AVERAGE RATE OF 168 LBS. PER SQ. YD.
D	PROP. APPROX. 4 1/2" ASPHALT CONCRETE INTERMEDIATE COURSE, TYPE I19.0C, AT AN AVERAGE RATE OF 513 LBS. PER SQ. YD.
R	CONCRETE STRUCTURE
U	EXISTING PAVEMENT.
V1	1 1/2" MILLING
V2	4 1/2" MILLING

22-JAN-2019 08:59 S:\DDC\Resurfacing\Projects\2020 P0 Contracts\Alamance\2020CPT.07.07.10011\CADD\2020CPT.07.07.10011_typ.dgn cthskins AT DIV07-300050

STATE	PROJECT NO.	SHEET NO.
N.C.	2020CPT.07.07.10011	3

TO BE USED AT ALL
NON-SIGNALIZED INTERSECTIONS

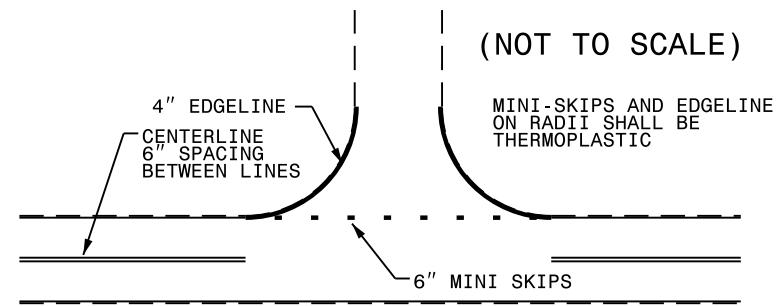

NOTE: MINI SKIPS SHALL BE PLACED ON A 8' CYCLE, CONTAINING AN 6' AND 2' SKIP, THE WIDTH OF THE SKIP SHALL BE 6".

PAVING DETAIL 1
MAIN LINE IS BEING RESURFACED

NOTE: NON-SYSTEM (CITY STREET, PRIVATE DRIVE, SCHOOL BUS DRIVE)

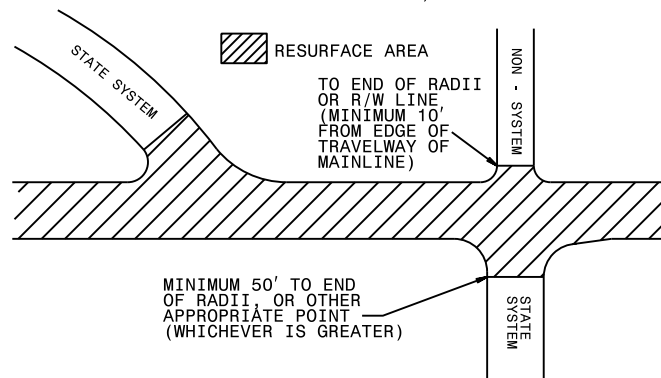

PAVING DETAIL 2
MAIN LINE IS NOT BEING RESURFACED

MAPS ENDING IN A TEE INTERSECTION

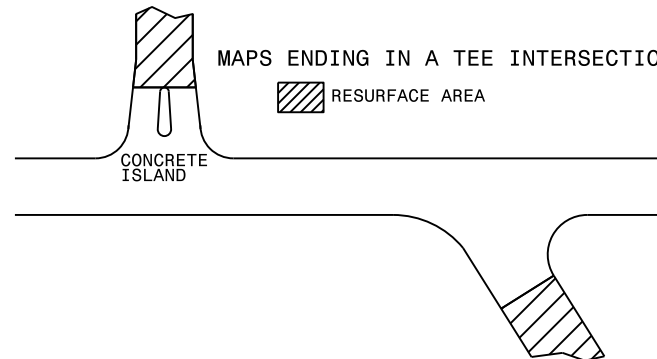

INCIDENTAL MILLING DETAIL

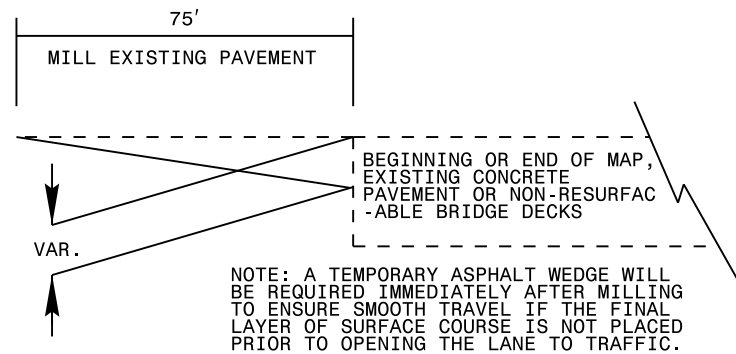

PAVEMENT SCHEDULE

C	PROP. APPROX. 1½" ASPHALT CONCRETE SURFACE COURSE, TYPE S9.5C, AT AN AVERAGE RATE OF 168 LBS. PER SQ. YD.		
D	PROP. APPROX. 4½" ASPHALT CONCRETE INTERMEDIATE COURSE, TYPE I19.0C, AT AN AVERAGE RATE OF 513 LBS. PER SQ. YD.		
R	CONCRETE STRUCTURE	U	EXISTING PAVEMENT.
V1	1½" MILLING	V2	4½" MILLING



2020CPT.07.07.10011

Sheet No. 3-A

Alamance County

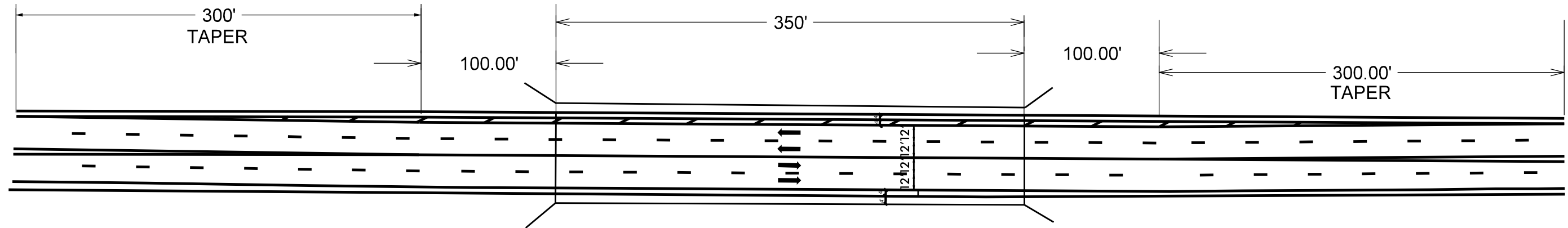

Striping Qts. for Bridge over Haw River
Polyurea (HRE) white (4"-20Mils) = 1235 LF
Polyurea (HRE) Yellow (4"-20Mils) = 710 LF
Cold Applied plastic Pavement marking lines Type II(8") = 80 LF
4" Line Removal = 1590 LF

Haw River

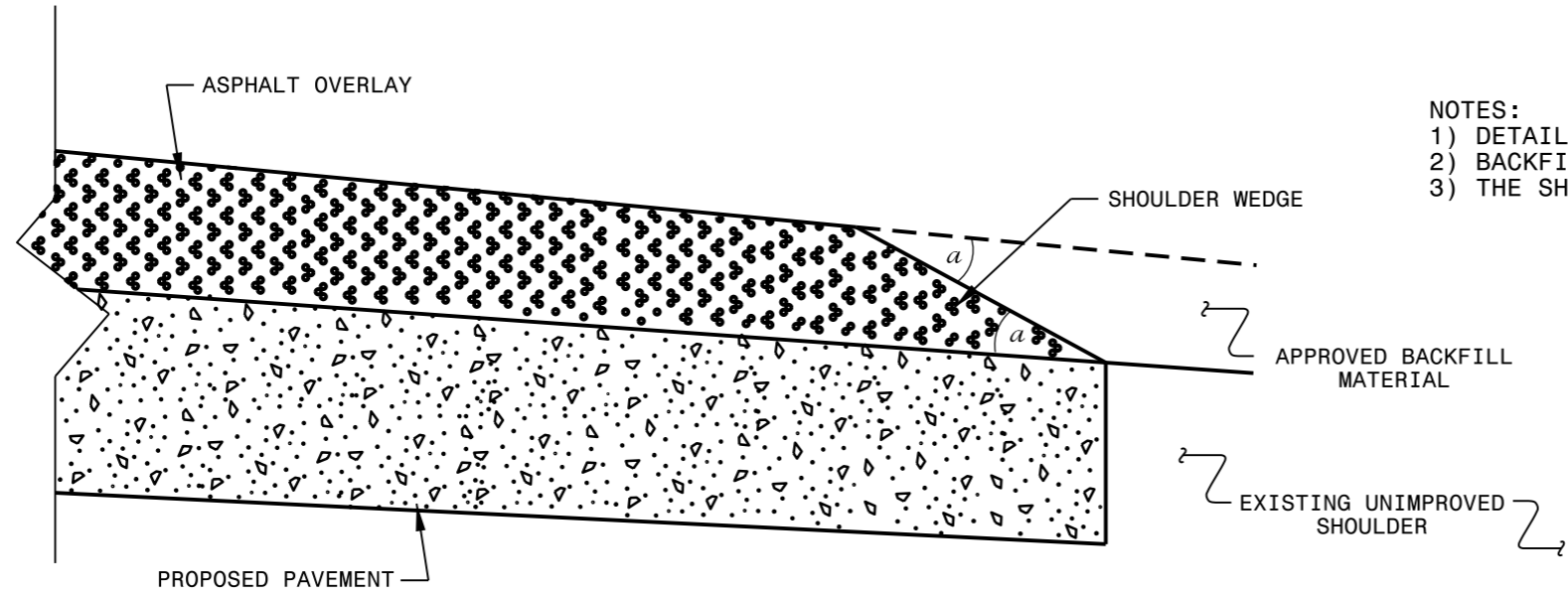

- NOTES:
- 1) DETAIL DOES NOT APPLY TO OGAFB AND ULTRA-THIN BONDED WEARING COURSE.
 - 2) BACKFILL SHOULDER WITH APPROVED MATERIAL.
 - 3) THE SHOULDER WEDGE DEVICE MAY BE DISENGAGED AT PAVED DRIVEWAYS AND SIDE STREETS.

SHOULDER WEDGE DETAIL
 (Resurfacing Projects w/ Widening or
 with Existing Paved Shoulder having no dropoffs)

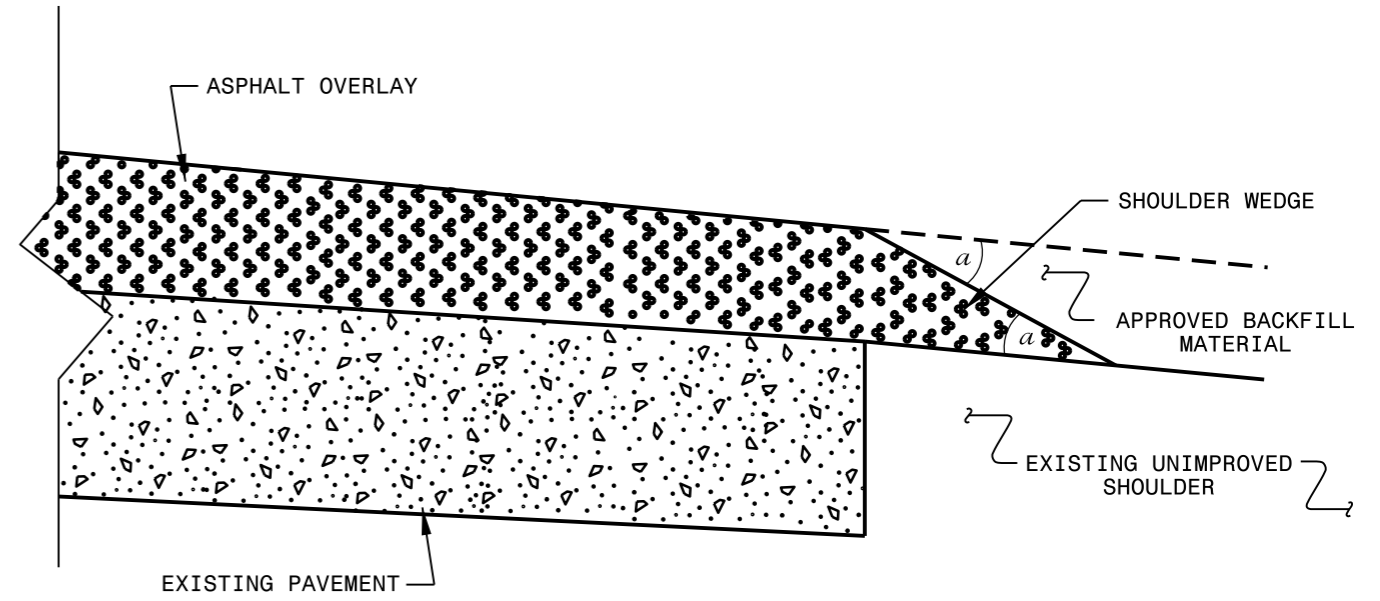

SHOULDER WEDGE DETAIL
 (Resurfacing Projects w/ NO Widening)

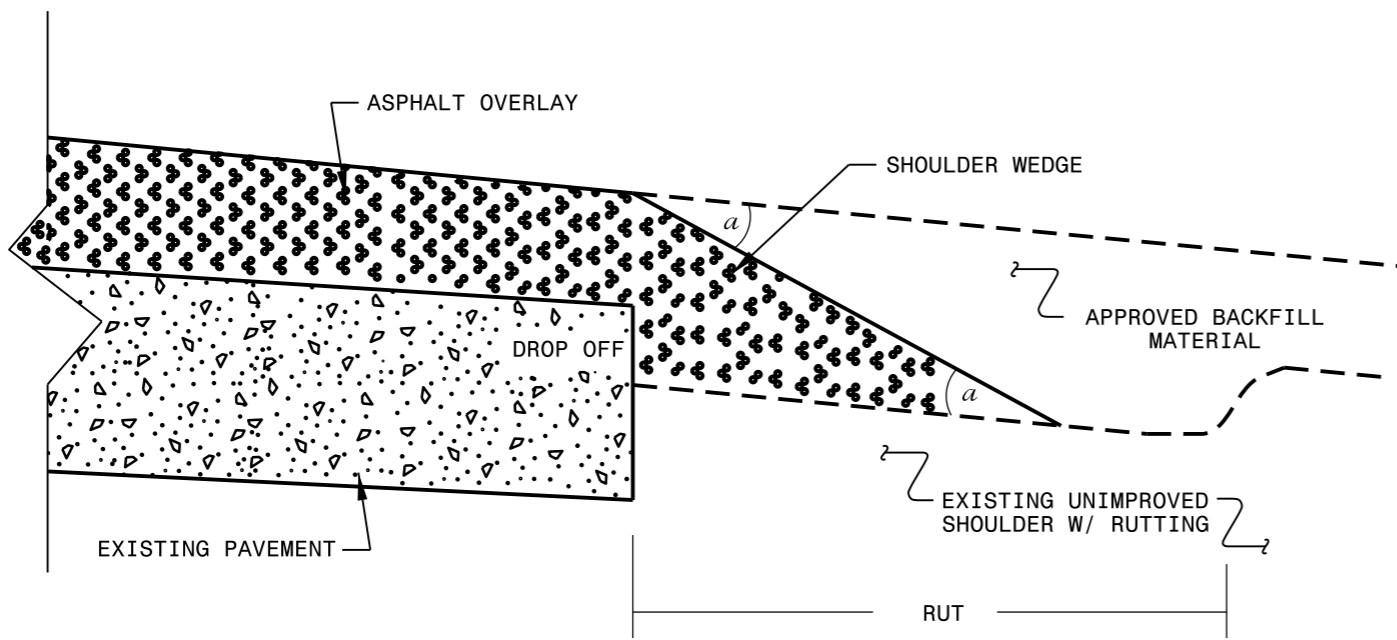

SHOULDER WEDGE DETAIL
 (Resurfacing Adjacent to
 Rutted Shoulder)

- SHOULDER WEDGE ANGLE = 30°

**CONTRACT STANDARDS
 AND DEVELOPMENT UNIT**
 Office 919-707-6950 FAX 919-250-4119

**SHOULDER WEDGE
 DETAILS**

ORIGINAL BY: T.SPELL DATE: 7-19-11
 MODIFIED BY: DATE: 10/16/12
 CHECKED BY: DATE:
 FILE SPEC.: s:\usr\details\stand\shoulderwedgedetail.dgn

24-JAN-2019 07:30
 s:\usr\Resurf\proj\2020 PO Contracts\Alamence\2020CPT.07.07.10011\CA00\Shoulder Wedge Detail.dgn
 c:\haskins

High Speed Detection (≥40 mph)

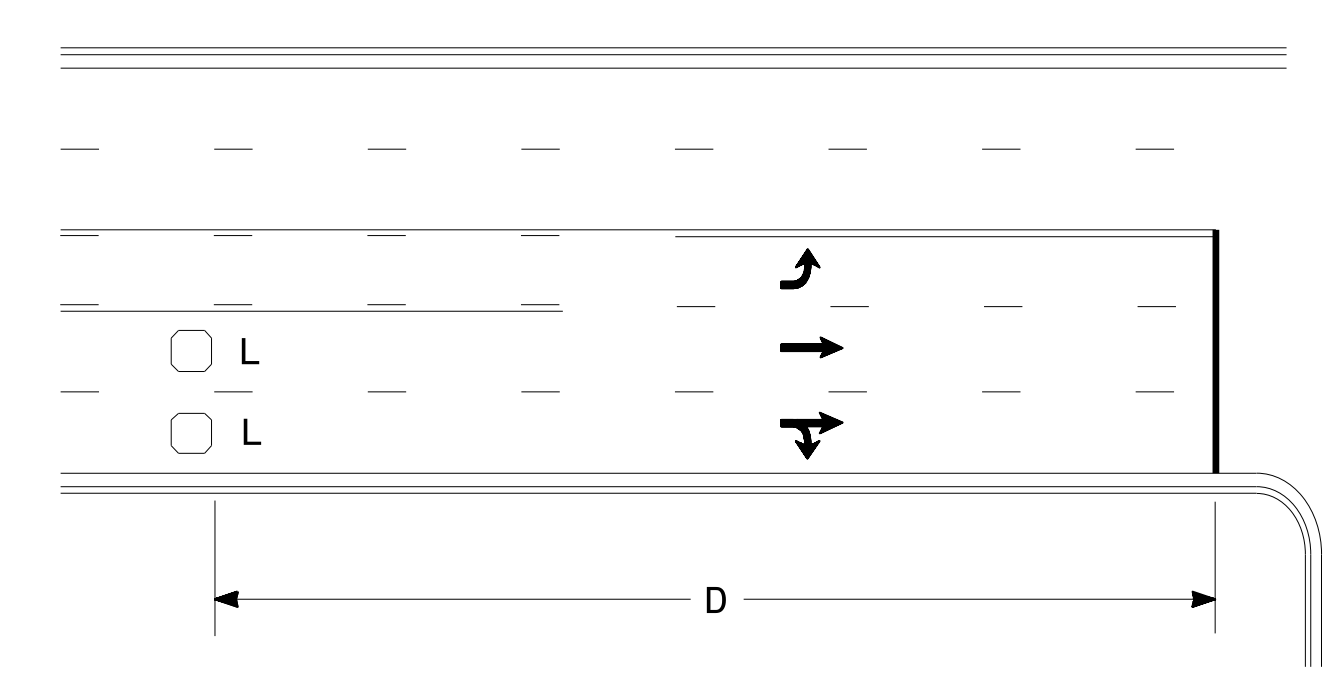

Speed Limit mph	D ft
40	250
45	300
50	355
55	420

L = 6ft X 6ft
Wired in series for TS1
Controllers
Wired separately for TS2,
170, and 2070L Controllers

Volume Density Operation

OR

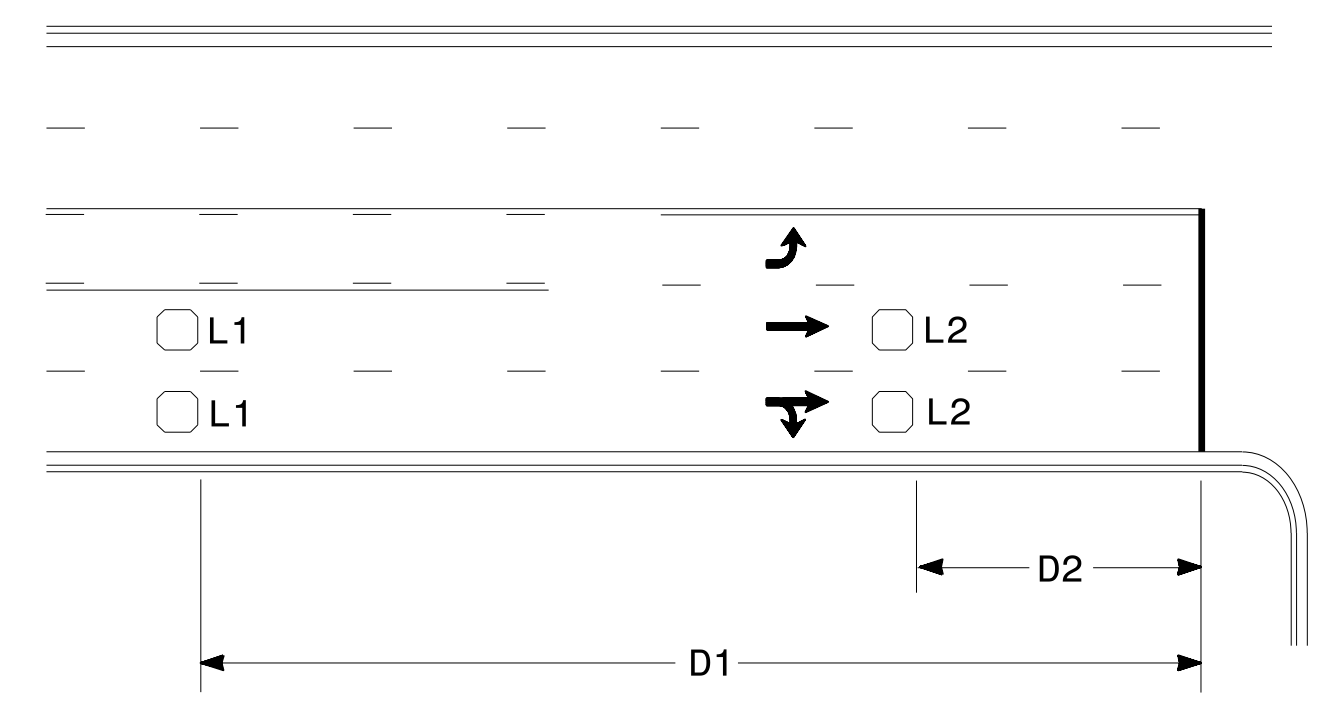

Speed Limit mph	D1 ft	D2 ft
40	250	80
45	300	90
50	355	100
55	420	110

L1 = 6ft X 6ft
Wired in series
L2 = 6ft X 6ft
Wired in series

"Stretch" Operation

Low Speed Detection (≤35 mph)

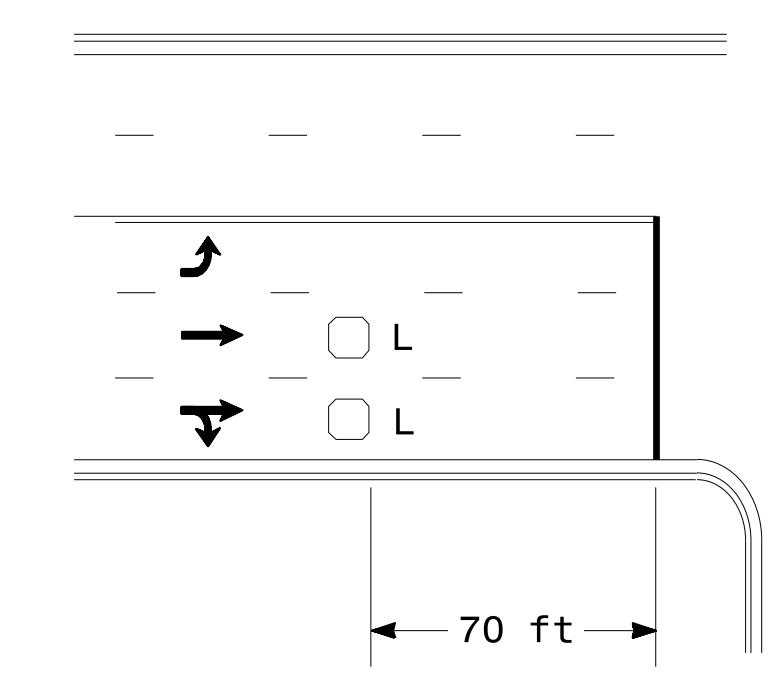

L = 6ft X 6ft
Wired in series

OR

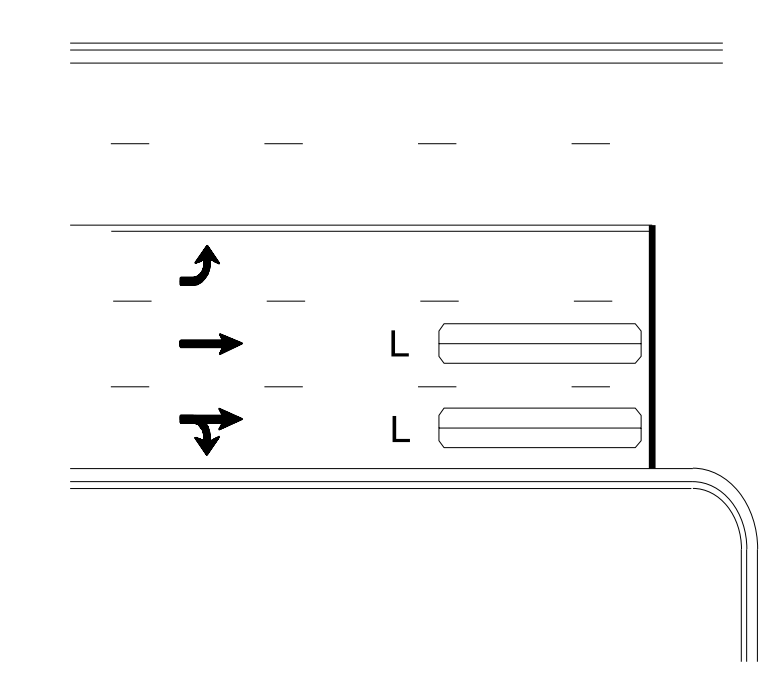

L = 6ft X 40ft
Quadrupole loop, wired separately

Left Turn Lane Detection

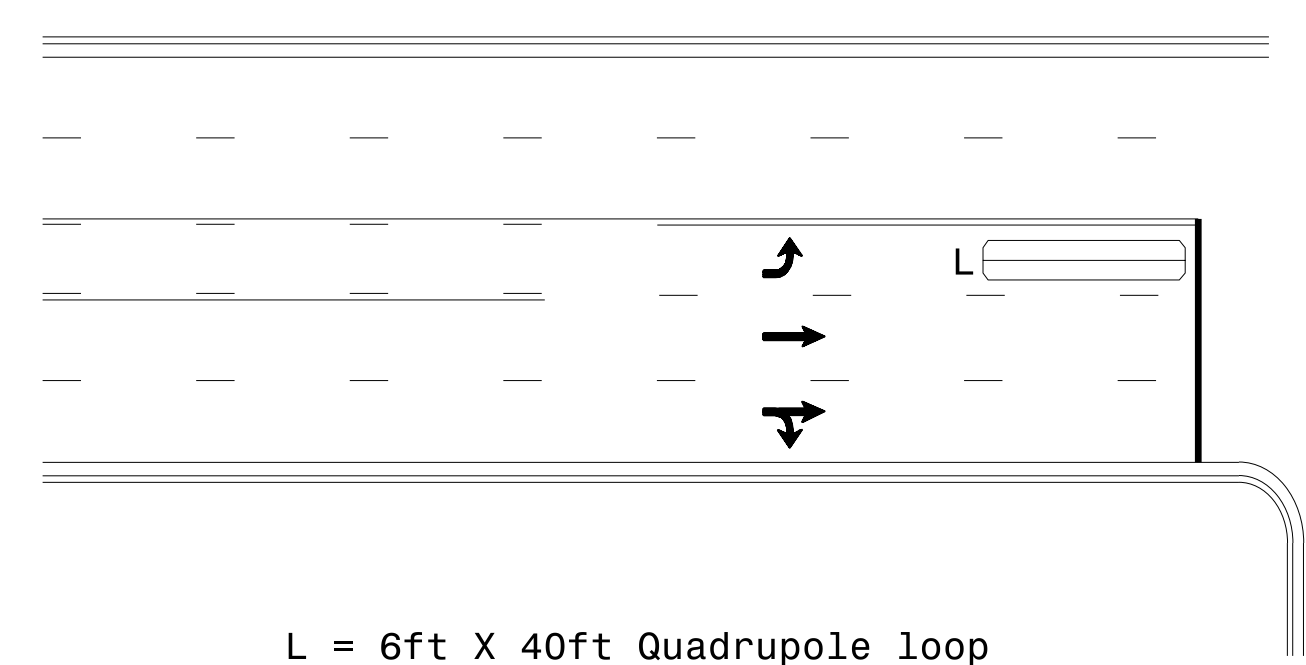

L = 6ft X 40ft Quadrupole loop

Presence Loop Detection

OR

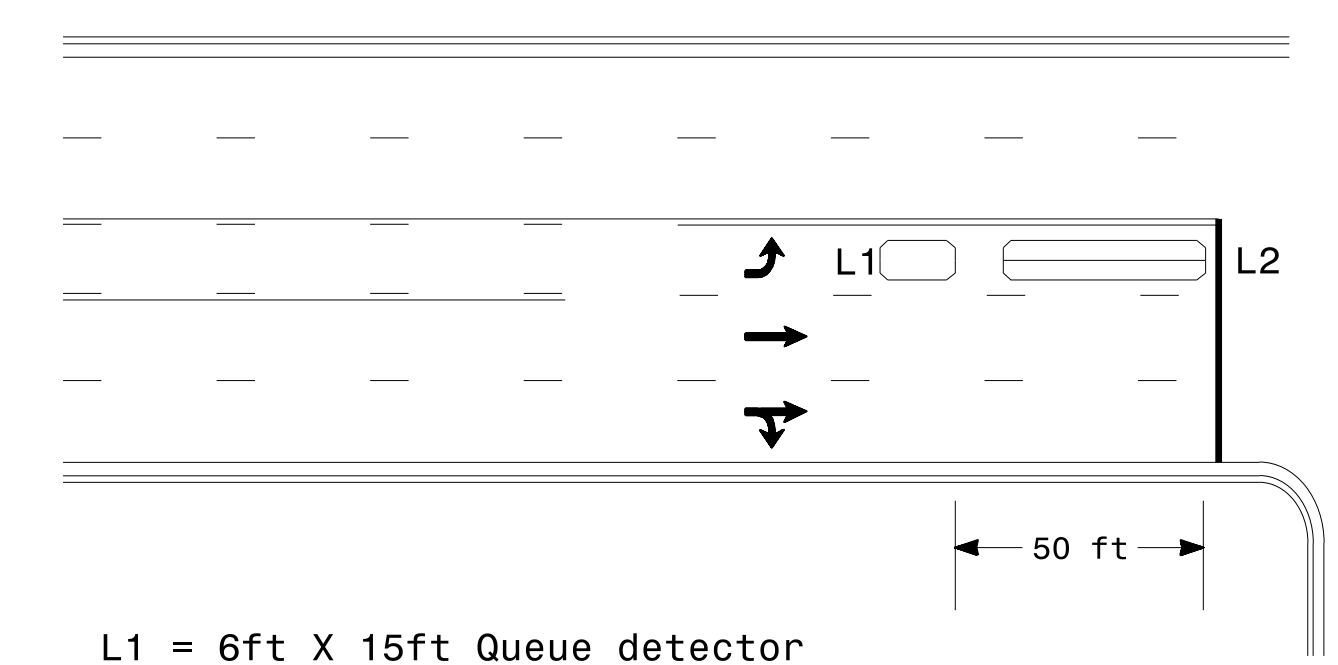

L1 = 6ft X 15ft Queue detector
L2 = 6ft X 40ft Quadrupole loop

Queue Loop Detection

Right Turn Lane Detection

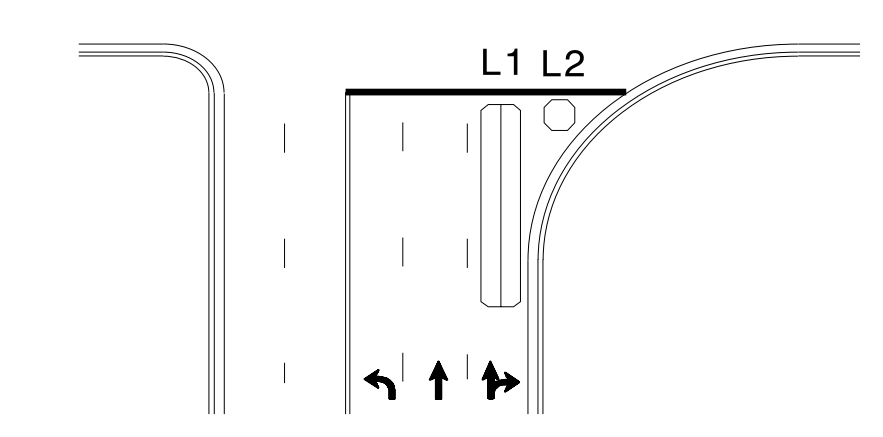

Shared Lane/
Wide Radius Turn

L1 = 6ft X 40ft Quadrupole loop
L2 = 6ft X 6ft [Minimum] Presence loop
Wired separately

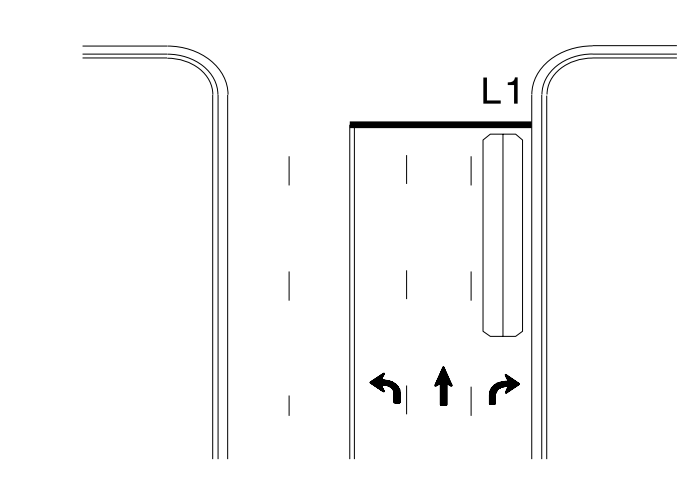

Standard Turn

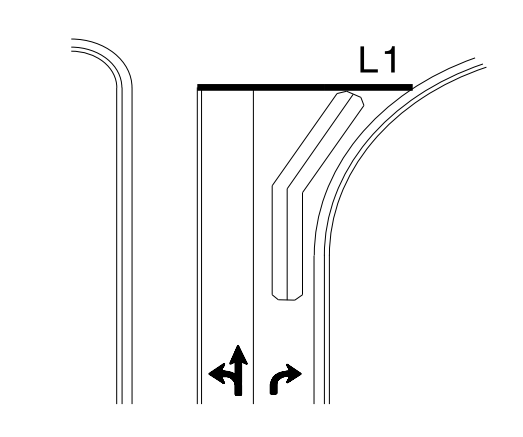

Wide Radius Turn

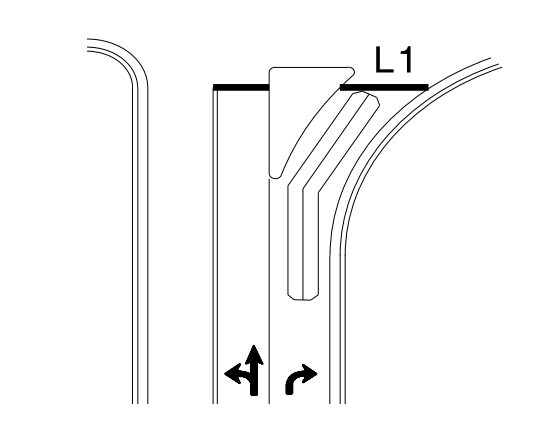

Channelized Turn

Side Street Detection

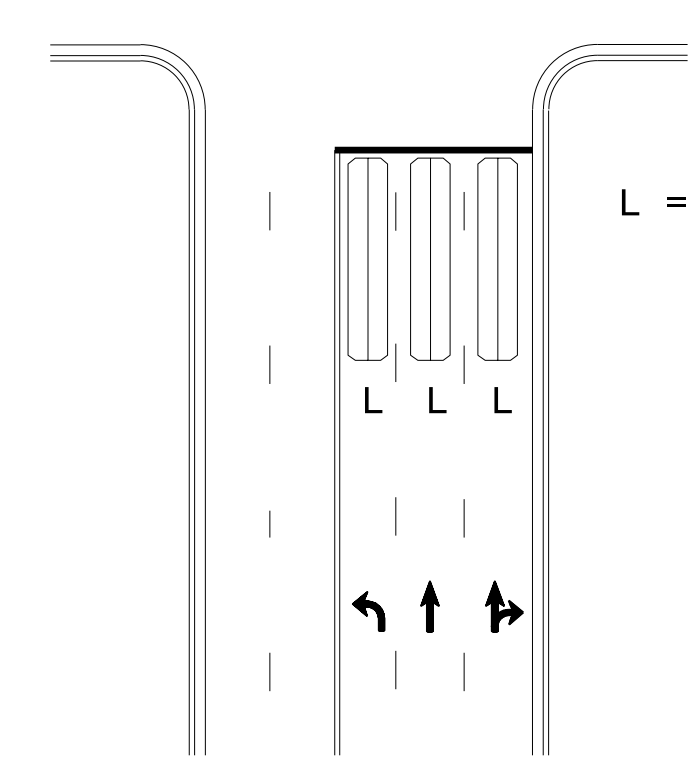

L = 6ft X 40ft
Quadrupole loop
Wired to separate
detectors/channels

Presence Loop Placement at Stop Lines

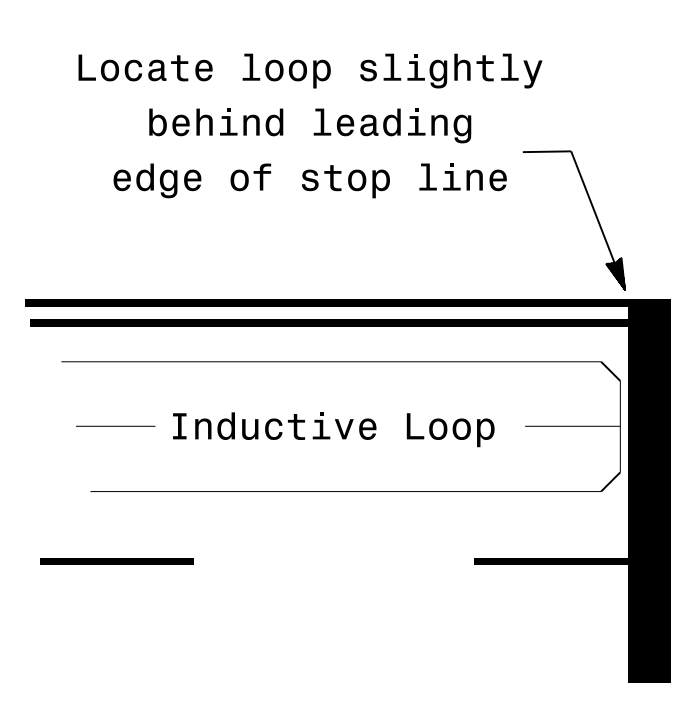

Locate loop slightly
behind leading
edge of stop line

Note:
Loop may be located in advance
of stop line under any of the
following conditions:
1) stop line is greater than 15'
from edge of intersecting
roadway
2) loop detects a permissive or
protected/permissive left turn
3) for an exclusive right turn
lane

Recommended Number of Turns

Single 6' X 6' loop
(when wired separately):

Length of Lead-in ft	Number of Turns
< 250	3
250-375	4
375-525	5
> 525	6

Quadrupole loops: Use 2-4-2 turns
6' X 15' Loops:
Lead-in < 150', use 2 turns
Lead-in > 150', use 3 turns

750 N. Greenfield Pkwy, Garner, NC 27529

Typical Signal Loop Locations

PLAN DATE: January 2015	REVIEWED BY: JPG
PREPARED BY: PLA	REVIEWED BY:
REVISIONS	INIT. DATE

SEAL
NORTH CAROLINA
PROFESSIONAL ENGINEER
PAMELA L. ALEXANDER
23489

DocuSigned by:
P. Alexander
1/30/2015 10:44:44 AM

SIG. INVENTORY NO.

NOTES

- OVERLAP SAW CUTS AT CORNERS AND INTERSECTION POINTS TO ENSURE UNIFORM SAW SLOT DEPTH.
- MAINTAIN 12" SPACING BETWEEN LOOP WIRE TAIL SECTIONS.
- WIRE LOOPS CONNECTED TO THE SAME DETECTOR IN SERIES.
- LOCATE LOOPS IN CENTER OF LANES UNLESS OTHERWISE SHOWN ON PLANS.
- USE A SERIES OF ONE INCH PIECES OF BACKER ROD SPACED ONE FOOT APART ALONG THE ENTIRE LENGTH OF THE FEEDER SLOT AND LOOP SAW SLOT.
- CONSULT LOOP SEALANT MANUFACTURER TO DETERMINE CURING TIME REQUIRED PRIOR TO MILLING.

SAW SLOT DEPTH CHART
ASSUMING 2" MILLING DEPTH

DEPTH (IN)	NO. OF WIRE LAYERS				
	2	3	4	5	6
SAW SLOT DEPTH	4.0	4.5	5.0	5.0	5.0
MINIMUM TOTAL ASPHALT DEPTH REQUIRED	5.0	5.5	6.0	6.0	6.0

LOOP WIRE TWISTING METHOD

INCORRECT WAY TO TWIST WIRE



CORRECT WAY TO TWIST WIRE



CONVENTIONAL 4-SIDED LOOP

SAW CUT OPTIONS

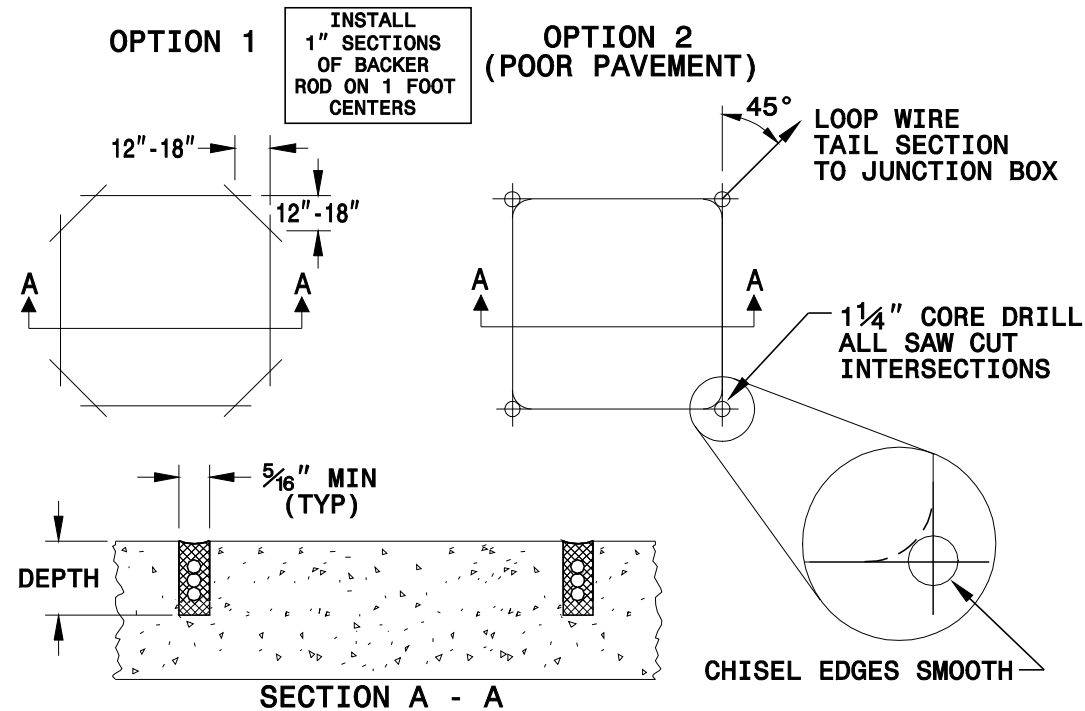

LOOP WINDING METHOD

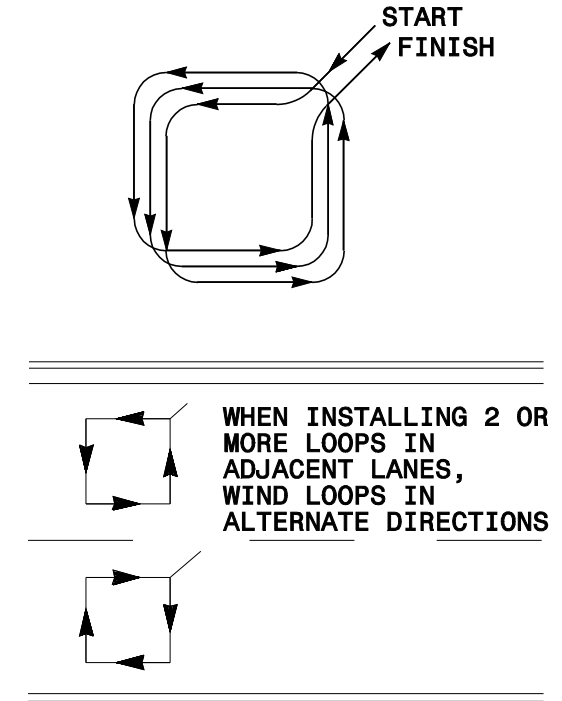

QUADRUPOLE LOOP

SAW CUT OPTIONS

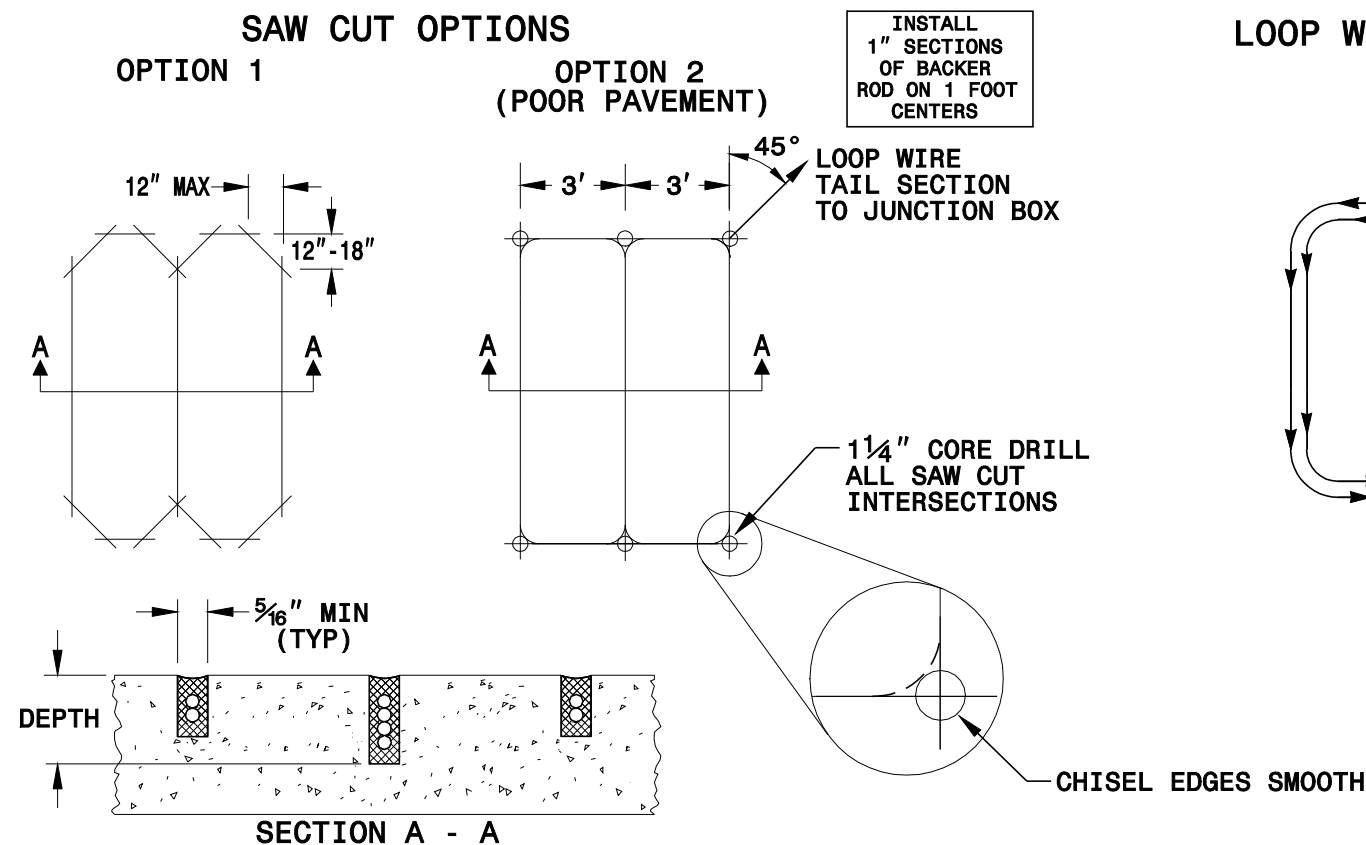

LOOP WINDING METHOD

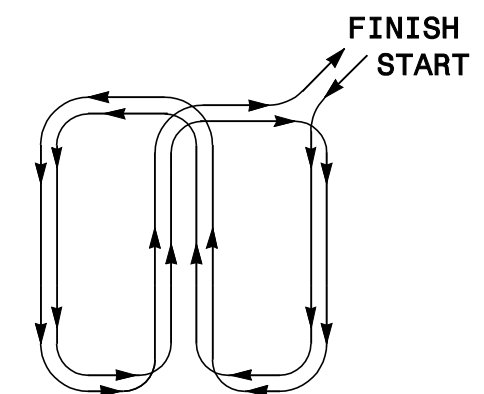

STATE OF NORTH CAROLINA
DEPT. OF TRANSPORTATION
DIVISION OF HIGHWAYS
RALEIGH, N.C.

ENGLISH STANDARD DRAWING FOR
DEEP-CUT INDUCTIVE DETECTION LOOPS
(FOR INSTALLATION PRIOR TO MILLING)

STATE OF NORTH CAROLINA
DEPT. OF TRANSPORTATION
DIVISION OF HIGHWAYS
RALEIGH, N.C.

ENGLISH STANDARD DRAWING FOR
DEEP-CUT INDUCTIVE DETECTION LOOPS
(FOR INSTALLATION PRIOR TO MILLING)

REVISIONS
REMOVED TWISTING NOTES FROM TAIL SECT. TO JUNCTION BOX. 2/26/08 MWH

PROJECT NO.	SHEET NO.
2020CPT.07.07.10011	7

SUMMARY OF QUANTITIES

PROJECT NO	COUNTY	MAP NO	ROUTE	DESCRIPTION	TYP NO	LANES	LANE TYPE	FINAL SURFACE TESTING REQUIRED	WARM MIX ASPHALT REQUIRED	LENGTH	WIDTH	INCIDENTAL STONE BASE	MILLING ASPHALT PAVEMENT, 1½" DEPTH	ASPHALT CONC SURFACE COURSE, TYPE S9.5C	ASPHALT BINDER FOR PLANT MIX	PATCHING EXISTING PAVEMENT	ADI. OF MANHOLES	ADJUSTMENT OF METER BOXES OR VALVE BOXES	PORTABLE LIGHTING	TRENCHING (PAVED) (1)(2")	JUNCTION BOX (STANDARD SIZE)	INDUCTIVE LOOP SAW CUT	LEAD-IN CABLE (14-2)									
										MI	FT		TONS	SY	TONS			TON		EA	EA	LS	LF	EA	LF	LF						
2020CPT.07.07.10011	Alamance	1	US 70 EB (CHURCH ST.)	FROM 5TH ST (NON-SYSTEM), 5.66 TO 380' WEST OF SR 1928 (TROLLINGWOOD RD), 11.48	1	4	MU	NO	NO	0.017	48	15	479	40	2	250			1				75									
					1	4	MU	NO	NO	0.027	71		1,125	95	6		1	1														
					2	3	MD	NO	NO	0.319	42		9,803	822	49		15	12														
					2	3	MD	NO	NO	0.152	40		5,980	501	30		2															
					2	3	MD	NO	NO	0.088	36		2,830	237	14		3	5														
					2	3	MD	NO	NO	0.059	39		1,350	114	7		1															
					2	3	MD	NO	NO	0.03	41		722	61	4		1															
					2	3	MD	NO	NO	0.208	40		6,101	511	31		10	5														
					3	3	MD	NO	NO	0.441	36		11,506	965	58		3	6														
					3	2	MU	NO	NO	0.026	83		1,266	107	6																	
				3	6	MU	NO	NO	0.943	77		47,689	4,004	240		38	34								2,885							
				SKIP GRAHAM-HOPEDALE INTERSECTION, 7.96 - 8.17									0.216																			
									3	6	MU	NO	NO	0.288	77		14,242	1,195	72		12	5					1,520					
									3	6	MU	NO	NO	0.046	69		1,903	157	9		1	1										
									3	5	MU	NO	NO	0.979	60		36,830	3,096	186		13	19								1,300		
									3	2	MU	NO	NO	0.028	62		1,019	86	5		1											
									3	6	MU	NO	NO	0.033	64		1,239	104	6													
									3	6	MU	NO	NO	0.029	66		3,289	275	16												750	
									4	5	MU	NO	NO	0.022	68		878	74	4													
									4	4	MU	NO	NO	0.085	63		4,559	384	23													
									4	4	MU	NO	NO	0.423	57		15,913	1,336	80													
									4	4	MU	NO	NO	0.066																		
				SKIP BRIDGE OVER HAW RIVER					4	4	MU	NO	NO	0.657	57		23,371	1,965	118													
									4	4	MU	NO	NO	0.058	65		2,853	241	14													
									4	5	2WU	NO	NO	0.083	72		4,005	335	20													
									4	5	MU	NO	NO	0.044	71		2,529	214	13													
									4	5	MU	NO	NO	0.117	62		7,483	623	37		2	6			20	1		1,810	225			
									4	2	2WU	NO	NO	0.065	43		1,872	158	9													
									4	2	2WU	NO	NO	0.251	30		5,023	423	25		4	6										
									TOTAL FOR MAP NO. 1									5.8		15	215,859	18,123	1,084	250	107	100	1	20	1	8,340	225	
2020CPT.07.07.10011	Alamance	2	US 70 WB (FISHER ST.)	FROM SPLIT, 9.56 TO SPLIT, 10.97	3	3	MD	NO	NO	0.03	39		686	58	3		2															
					3	3	MD	NO	NO	0.104	37		2,258	190	11																	
					3	3	MD	NO	NO	0.517	36		13,344	1,120	67		8	5							1,070							
					3	3	MD	NO	NO	0.003	35		62	5																		
					3	3	MD	NO	NO	0.058	33		1,361	115	7		2	1														
					3	3	MD	NO	NO	0.717	36		20,655	1,731	104		17	15								1,070						
TOTAL FOR MAP NO. 2									1.429			38,366	3,219	192		29	21					1,070										
TOTAL FOR PROJ NO. 2020CPT.07.07.10011									7.229		15	254,225	21,342	1,276	250	136	121	1	20	1	9,410	225										
GRAND TOTAL									7.229		15	254,225	21,342	1,276	250	136	121	1	20	1	9,410	225										

