

STATE OF NORTH CAROLINA
DEPARTMENT OF TRANSPORTATION
RALEIGH, N.C.

C203788

CONTRACT AND
CONTRACT BONDS

FOR CONTRACT NO. C203788

WBS 50092.3.1 HSIP-0074(156)

T.I.P NO. W-5520

COUNTY OF UNION

THIS IS THE ROADWAY & STRUCTURE CONTRACT

ROUTE NUMBER US 74 LENGTH 2.471 MILES

LOCATION US-74 FROM 1100 FEET WEST OF INDIAN TRAIL-FAIRVIEW ROAD TO
1200 FEET EAST OF SARDIS CHURCH ROAD.

CONTRACTOR SEALAND CONTRACTORS CORP

ADDRESS 1708 N CALDWELL ST
CHARLOTTE, NC 28206

BIDS OPENED APRIL 18, 2017

CONTRACT EXECUTION 5/2/2017

STATE OF NORTH CAROLINA
DEPARTMENT OF TRANSPORTATION
RALEIGH, N.C.

PROPOSAL

DATE AND TIME OF BID OPENING: **APRIL 18, 2017 AT 2:00 PM**

CONTRACT ID C203788
WBS 50092.3.1

FEDERAL-AID NO. HSIP-0074(156)
COUNTY UNION
T.I.P. NO. W-5520
MILES 2.471
ROUTE NO. US 74
LOCATION US-74 FROM 1100 FEET WEST OF INDIAN TRAIL-FAIRVIEW ROAD TO
1200 FEET EAST OF SARDIS CHURCH ROAD.

TYPE OF WORK GRADING, DRAINAGE, PAVING, SIGNALS, AND RETAINING WALL.

NOTICE:

ALL BIDDERS SHALL COMPLY WITH ALL APPLICABLE LAWS REGULATING THE PRACTICE OF GENERAL CONTRACTING AS CONTAINED IN CHAPTER 87 OF THE GENERAL STATUTES OF NORTH CAROLINA WHICH REQUIRES THE BIDDER TO BE LICENSED BY THE N.C. LICENSING BOARD FOR CONTRACTORS WHEN BIDDING ON ANY NON-FEDERAL AID PROJECT WHERE THE BID IS \$30,000 OR MORE, EXCEPT FOR CERTAIN SPECIALTY WORK AS DETERMINED BY THE LICENSING BOARD. BIDDERS SHALL ALSO COMPLY WITH ALL OTHER APPLICABLE LAWS REGULATING THE PRACTICES OF ELECTRICAL, PLUMBING, HEATING AND AIR CONDITIONING AND REFRIGERATION CONTRACTING AS CONTAINED IN CHAPTER 87 OF THE GENERAL STATUTES OF NORTH CAROLINA. NOTWITHSTANDING THESE LIMITATIONS ON BIDDING, THE BIDDER WHO IS AWARDED ANY FEDERAL - AID FUNDED PROJECT SHALL COMPLY WITH CHAPTER 87 OF THE GENERAL STATUTES OF NORTH CAROLINA FOR LICENSING REQUIREMENTS WITHIN 60 CALENDAR DAYS OF BID OPENING.

BIDS WILL BE RECEIVED AS SHOWN BELOW:

THIS IS A ROADWAY & STRUCTURE PROPOSAL

5% BID BOND OR BID DEPOSIT REQUIRED

**PROPOSAL FOR THE CONSTRUCTION OF
CONTRACT No. C203788 IN UNION COUNTY, NORTH CAROLINA**

Date _____ 20 _____

**DEPARTMENT OF TRANSPORTATION,
RALEIGH, NORTH CAROLINA**

The Bidder has carefully examined the location of the proposed work to be known as Contract No. **C203788**; has carefully examined the plans and specifications, which are acknowledged to be part of the proposal, the special provisions, the proposal, the form of contract, and the forms of contract payment bond and contract performance bond; and thoroughly understands the stipulations, requirements and provisions. The undersigned bidder agrees to be bound upon his execution of the bid and subsequent award to him by the Board of Transportation in accordance with this proposal to provide the necessary contract payment bond and contract performance bond within fourteen days after the written notice of award is received by him. The undersigned Bidder further agrees to provide all necessary machinery, tools, labor, and other means of construction; and to do all the work and to furnish all materials, except as otherwise noted, necessary to perform and complete the said contract in accordance with *the 2012 Standard Specifications for Roads and Structures* by the dates(s) specified in the Project Special Provisions and in accordance with the requirements of the Engineer, and at the unit or lump sum prices, as the case may be, for the various items given on the sheets contained herein.

The Bidder shall provide and furnish all the materials, machinery, implements, appliances and tools, and perform the work and required labor to construct and complete State Highway Contract No. **C203788 in Union County**, for the unit or lump sum prices, as the case may be, bid by the Bidder in his bid and according to the proposal, plans, and specifications prepared by said Department, which proposal, plans, and specifications show the details covering this project, and hereby become a part of this contract.

The published volume entitled *North Carolina Department of Transportation, Raleigh, Standard Specifications for Roads and Structures, January 2012* with all amendments and supplements thereto, is by reference incorporated into and made a part of this contract; that, except as herein modified, all the construction and work included in this contract is to be done in accordance with the specifications contained in said volume, and amendments and supplements thereto, under the direction of the Engineer.

If the proposal is accepted and the award is made, the contract is valid only when signed either by the Contract Officer or such other person as may be designated by the Secretary to sign for the Department of Transportation. The conditions and provisions herein cannot be changed except over the signature of the said Contract Officer.

The quantities shown in the itemized proposal for the project are considered to be approximate only and are given as the basis for comparison of bids. The Department of Transportation may increase or decrease the quantity of any item or portion of the work as may be deemed necessary or expedient.

An increase or decrease in the quantity of an item will not be regarded as sufficient ground for an increase or decrease in the unit prices, nor in the time allowed for the completion of the work, except as provided for the contract.

Accompanying this bid is a bid bond secured by a corporate surety, or certified check payable to the order of the Department of Transportation, for five percent of the total bid price, which deposit is to be forfeited as liquidated damages in case this bid is accepted and the Bidder shall fail to provide the required payment and performance bonds with the Department of Transportation, under the condition of this proposal, within 14 calendar days after the written notice of award is received by him, as provided in the *Standard Specifications*; otherwise said deposit will be returned to the Bidder.



Administrator of Technical Services



Proposals and Contracts Engineer

DocuSigned by:

3/13/2017

Rodger D. Rochelle

AD7EBA97E6014A0...

DocuSigned by:

3/13/2017

Jonathan A. Gay

1C72C8D1867C48E...

TABLE OF CONTENTS

**COVER SHEET
PROPOSAL SHEET**

PROJECT SPECIAL PROVISIONS

CONTRACT TIME AND LIQUIDATED DAMAGES: G-1
INTERMEDIATE CONTRACT TIME NUMBER 1 AND LIQUIDATED DAMAGES: G-1
INTERMEDIATE CONTRACT TIME NUMBER 2 AND LIQUIDATED DAMAGES: G-2
INTERMEDIATE CONTRACT TIME NUMBER 3 AND LIQUIDATED DAMAGES: G-3
INTERMEDIATE CONTRACT TIME NUMBER 4 AND LIQUIDATED DAMAGES: G-3
INTERMEDIATE CONTRACT TIME NUMBER 5 AND LIQUIDATED DAMAGES: G-4
PERMANENT VEGETATION ESTABLISHMENT:..... G-4
MAJOR CONTRACT ITEMS: G-5
SPECIALTY ITEMS:..... G-5
FUEL PRICE ADJUSTMENT:..... G-5
SCHEDULE OF ESTIMATED COMPLETION PROGRESS:..... G-6
DISADVANTAGED BUSINESS ENTERPRISE: G-6
CERTIFICATION FOR FEDERAL-AID CONTRACTS: G-20
CONTRACTOR'S LICENSE REQUIREMENTS: G-20
U.S. DEPARTMENT OF TRANSPORTATION HOTLINE: G-20
CARGO PREFERENCE ACT: G-21
SUBSURFACE INFORMATION:..... G-21
LOCATING EXISTING UNDERGROUND UTILITIES:..... G-21
VALUE ENGINEERING PROPOSAL: G-22
RESOURCE CONSERVATION AND ENV. SUSTAINABLE PRACTICES:..... G-23
DOMESTIC STEEL: G-23
MAINTENANCE OF THE PROJECT: G-24
COOPERATION BETWEEN CONTRACTORS:..... G-24
TWELVE MONTH GUARANTEE: G-25
IRAN DIVESTMENT ACT: G-25
GIFTS FROM VENDORS AND CONTRACTORS: G-26
LIABILITY INSURANCE:..... G-26
EROSION AND SEDIMENT CONTROL/STORMWATER CERTIFICATION: G-27
PROCEDURE FOR MONITORING BORROW PIT DISCHARGE:..... G-32
EMPLOYMENT:..... G-34
STATE HIGHWAY ADMINISTRATOR TITLE CHANGE:..... G-34
SUBLETTING OF CONTRACT: G-34

ROADWAY R-1

STANDARD SPECIAL PROVISIONS

AVAILABILITY FUNDS – TERMINATION OF CONTRACTS SSP-1
NCDOT GENERAL SEED SPECIFICATION FOR SEED QUALITY SSP-2
ERRATA..... SSP-5
PLANT AND PEST QUARANTINES SSP-7

AWARD OF CONTRACT SSP-8
 MINORITY AND FEMALE EMPLOYMENT REQUIREMENTS SSP-13
 REQUIRED CONTRACT PROVISIONS FEDERAL-AID CONST. CONTRACTS SSP-16
 ON-THE-JOB TRAINING SSP-25
 NCDENR NAME CHANGE SSP-28
 MINIMUM WAGES SSP-29

UNIT PROJECT SPECIAL PROVISIONS

GEOTECHNICALGT-0.1
 PAVEMENT MARKINGS PM-1
 TRAFFIC CONTROL TC-1
 UTILITY CONSTRUCTION UC-1
 UTILITY BY OTHERSUBO-1
 EROSION CONTROLEC-1
 TRAFFIC SIGNALS TS-1

PROPOSAL ITEM SHEET

ITEM SHEET(S) (TAN SHEETS)

PROJECT SPECIAL PROVISIONS**GENERAL****CONTRACT TIME AND LIQUIDATED DAMAGES:**

(8-15-00) (Rev. 12-18-07)

108

SP1 G07 A

The date of availability for this contract is **May 31, 2017**, except that work in jurisdictional waters and wetlands shall not begin until a meeting between the DOT, Regulatory Agencies, and the Contractor is held as stipulated in the permits contained elsewhere in this proposal. This delay in availability has been considered in determining the contract time for this project.

The completion date for this contract is **April 30, 2019**.

Except where otherwise provided by the contract, observation periods required by the contract will not be a part of the work to be completed by the completion date and/or intermediate contract times stated in the contract. The acceptable completion of the observation periods that extend beyond the final completion date shall be a part of the work covered by the performance and payment bonds.

The liquidated damages for this contract are **Two Hundred Dollars (\$ 200.00)** per calendar day. These liquidated damages will not be cumulative with any liquidated damages which may become chargeable under Intermediate Contract Time Number 1.

INTERMEDIATE CONTRACT TIME NUMBER 1 AND LIQUIDATED DAMAGES:

(7-1-95) (Rev. 2-21-12)

108

SP1 G13 A

Except for that work required under the Project Special Provisions entitled *Planting, Reforestation* and/or *Permanent Vegetation Establishment*, included elsewhere in this proposal, the Contractor will be required to complete all work included in this contract and shall place and maintain traffic on same.

The date of availability for this intermediate contract time is **May 31, 2017**.

The completion date for this intermediate contract time is **November 1, 2018**.

The liquidated damages for this intermediate contract time are **One Thousand Five Hundred Dollars (\$ 1,500.00)** per calendar day.

Upon apparent completion of all the work required to be completed by this intermediate date, a final inspection will be held in accordance with Article 105-17 and upon acceptance, the Department will assume responsibility for the maintenance of all work except *Planting, Reforestation* and/or *Permanent Vegetation Establishment*. The Contractor will be responsible for and shall make corrections of all damages to the completed roadway caused by his planting operations, whether occurring prior to or after placing traffic through the project.

INTERMEDIATE CONTRACT TIME NUMBER 2 AND LIQUIDATED DAMAGES:

(2-20-07)

108

SP1 G14 A

The Contractor shall complete the required work of installing, maintaining, and removing the traffic control devices for lane closures and restoring traffic to the existing traffic pattern. The Contractor shall not close or narrow a lane of traffic on **Any Road** during the following time restrictions:

DAY AND TIME RESTRICTIONS

Monday thru Sunday 6:00 AM to 9:00 PM

In addition, the Contractor shall not close or narrow a lane of traffic on **Any Road**, detain and/or alter the traffic flow on or during holidays, holiday weekends, special events, or any other time when traffic is unusually heavy, including the following schedules:

HOLIDAY AND HOLIDAY WEEKEND LANE CLOSURE RESTRICTIONS

1. For **unexpected occurrence** that creates unusually high traffic volumes, as directed by the Engineer.
2. For **New Year's Day**, between the hours of **6:00 AM** December 31st and **9:00 PM** January 2nd. If New Year's Day is on a Friday, Saturday, Sunday or Monday, then until **9:00 PM** the following Tuesday.
3. For **Easter**, between the hours of **6:00 AM** Thursday and **9:00 PM** Monday.
4. For **Memorial Day**, between the hours of **6:00 AM** Friday and **9:00 PM** Tuesday.
5. For **Independence Day**, between the hours of **6:00 AM** the day before Independence Day and **9:00 PM** the day after Independence Day.

If **Independence Day** is on a Friday, Saturday, Sunday or Monday, then between the hours of **6:00 AM** the Thursday before Independence Day and **9:00 PM** the Tuesday after Independence Day.
6. For **Labor Day**, between the hours of **6:00 AM** Friday and **9:00 PM** Tuesday.
7. For **Thanksgiving Day**, between the hours of **6:00 AM** Tuesday and **9:00 PM** Monday.
8. For **Christmas**, between the hours of **6:00 AM** the Friday before the week of Christmas Day and **9:00 PM** the following Tuesday after the week of Christmas Day.

Holidays and holiday weekends shall include New Year's Day, Easter, Memorial Day, Independence Day, Labor Day, Thanksgiving, and Christmas. The Contractor shall schedule his work so that lane closures will not be required during these periods, unless otherwise directed by the Engineer.

The time of availability for this intermediate contract work shall be the time the Contractor begins to install all traffic control devices for lane closures according to the time restrictions listed herein.

The completion time for this intermediate contract work shall be the time the Contractor is required to complete the removal of all traffic control devices for lane closures according to the time restrictions stated above and place traffic in the existing traffic pattern.

The liquidated damages are **Five Hundred Dollars (\$ 500.00)** per fifteen (15) minute time period.

INTERMEDIATE CONTRACT TIME NUMBER 3 AND LIQUIDATED DAMAGES:

(2-20-07) (Rev. 6-18-13)

108

SP1 G14 F

The Contractor shall complete the work required for each **Area, Phase, & Step** listed below and shall place and maintain traffic on same.

- Area 1, Phase I, Step #5 (Sheet TMP-3)
- Area 1, Phase II, Step #2 (Sheet TMP-3A)
- Area 2, Phase I, Step #5 (Sheet TMP-10)
- Area 2, Phase II, Step #4 (Sheet TMP-10A)
- Area 2, Phase III, Step #2 (Sheet TMP-10A)
- Area 3, Phase I, Step #4 (Sheet TMP-20)
- Area 3, Phase II, Step #2 (Sheet TMP-20A)
- Area 4, Phase I, Step #7 (Sheet TMP-27)
- Area 4, Phase II, Step #2 (Sheet TMP-27A)

The time of availability for each intermediate contract time is the **Friday at 9:00 PM** that the Contractor elects to begin the work.

The completion time for each intermediate contract time is the following **Saturday at 6:00 AM** after the time of availability.

The liquidated damages are **Five Hundred Dollars (\$ 500.00)** per fifteen (15) minute time period for each **Area, Phase, & Step** listed above.

INTERMEDIATE CONTRACT TIME NUMBER 4 AND LIQUIDATED DAMAGES:

(2-20-07) (Rev. 6-18-13)

108

SP1 G14 H

The Contractor shall complete the work required of **Area 1, Phase II, Steps #1 & #2** as shown on Sheets **TMP- 3 and TMP-3A** and shall place and maintain traffic on same.

The date of availability for this intermediate contract time is the date the Contractor elects to begin the work.

The completion date for this intermediate contract time is the date which is **Sixty (60)** consecutive calendar days after and including the date of availability.

The liquidated damages are **Five Hundred Dollars (\$ 500.00)** per calendar day.

INTERMEDIATE CONTRACT TIME NUMBER 5 AND LIQUIDATED DAMAGES:

(2-20-07) (Rev. 6-18-13)

108

SP1 G14 H

The Contractor shall complete the work required for each **Area, Phase, & Step** listed below and shall place and maintain traffic on same.

- Area 2, Phase III, Steps #1 thru #2 (TMP-10A)
- Area 3, Phase II, Steps #1 thru #2 (TMP-20 & TMP-20A)
- Area 4, Phase II, Steps #1 thru #2 (TMP-27A)

The date of availability for each intermediate contract time is the date the Contractor elects to begin the work.

The completion date for each intermediate contract time is the date which is **Forty-Five (45)** consecutive calendar days after and including the date of availability.

The liquidated damages are **Five Hundred Dollars (\$ 500.00)** per calendar day for each **Area, Phase, & Step** listed above.

PERMANENT VEGETATION ESTABLISHMENT:

(2-16-12) (Rev. 10-15-13)

104

SP1 G16

Establish a permanent stand of the vegetation mixture shown in the contract. During the period between initial vegetation planting and final project acceptance, perform all work necessary to establish permanent vegetation on all erodible areas within the project limits, as well as, in borrow and waste pits. This work shall include erosion control device maintenance and installation, repair seeding and mulching, supplemental seeding and mulching, mowing, and fertilizer topdressing, as directed. All work shall be performed in accordance with the applicable section of the *2012 Standard Specifications*. All work required for initial vegetation planting shall be performed as a part of the work necessary for the completion and acceptance of the Intermediate Contract Time (ICT). Between the time of ICT and Final Project acceptance, or otherwise referred to as the vegetation establishment period, the Department will be responsible for preparing the required National Pollutant Discharge Elimination System (NPDES) inspection records.

Once the Engineer has determined that the permanent vegetation establishment requirement has been achieved at an 80% vegetation density (the amount of established vegetation per given area to stabilize the soil) and no erodible areas exist within the project limits, the Contractor will be notified to remove the remaining erosion control devices that are no longer needed. The Contractor will be responsible for, and shall correct any areas disturbed by operations performed in permanent vegetation establishment and the removal of temporary erosion control measures, whether occurring prior to or after placing traffic on the project.

Payment for *Response for Erosion Control, Seeding and Mulching, Repair Seeding, Supplemental Seeding, Mowing, Fertilizer Topdressing, Silt Excavation, and Stone for Erosion Control* will be made at contract unit prices for the affected items. Work required that is not represented by contract line items will be paid in accordance with Articles 104-7 or 104-3 of the *2012 Standard*

Specifications. No additional compensation will be made for maintenance and removal of temporary erosion control items.

MAJOR CONTRACT ITEMS:

(2-19-02)

104

SP1 G28

The following listed items are the major contract items for this contract (see Article 104-5 of the *2012 Standard Specifications*):

| Line # | Description |
|---------------|---------------------------------------------|
| 33 — | Asphalt Concrete Base Course, Type B25.0C |
| 35 — | Asphalt Concrete Surface Course, Type S9.5C |

SPECIALTY ITEMS:

(7-1-95)(Rev. 1-17-12)

108-6

SP1 G37

Items listed below will be the specialty items for this contract (see Article 108-6 of the *2012 Standard Specifications*).

| Line # | Description |
|---------------|-----------------------------|
| 66-69 | Guardrail |
| 74-80 | Signing |
| 90-99 and 105 | Long-Life Pavement Markings |
| 106 | Permanent Pavement Markers |
| 108-118 | Utility Construction |
| 119-144 | Erosion Control |
| 145-182 | Signals/ITS System |

FUEL PRICE ADJUSTMENT:

(11-15-05) (Rev. 2-18-14)

109-8

SP1 G43

Revise the *2012 Standard Specifications* as follows:

Page 1-83, Article 109-8, Fuel Price Adjustments, add the following:

The base index price for DIESEL #2 FUEL is \$ **1.7230** per gallon. Where any of the following are included as pay items in the contract, they will be eligible for fuel price adjustment.

The pay items and the fuel factor used in calculating adjustments to be made will be as follows:

| Description | Units | Fuel Usage Factor Diesel |
|-------------------------------------------------|--------------|---------------------------------|
| Unclassified Excavation | Gal/CY | 0.29 |
| Borrow Excavation | Gal/CY | 0.29 |
| Class IV Subgrade Stabilization | Gal/Ton | 0.55 |
| Aggregate Base Course | Gal/Ton | 0.55 |
| Sub-Ballast | Gal/Ton | 0.55 |
| Asphalt Concrete Base Course, Type ____ | Gal/Ton | 2.90 |
| Asphalt Concrete Intermediate Course, Type ____ | Gal/Ton | 2.90 |

| | | |
|------------------------------------------------|---------|-------|
| Asphalt Concrete Surface Course, Type ____ | Gal/Ton | 2.90 |
| Open-Graded Asphalt Friction Course | Gal/Ton | 2.90 |
| Permeable Asphalt Drainage Course, Type ____ | Gal/Ton | 2.90 |
| Sand Asphalt Surface Course, Type ____ | Gal/Ton | 2.90 |
| Aggregate for Cement Treated Base Course | Gal/Ton | 0.55 |
| Portland Cement for Cement Treated Base Course | Gal/Ton | 0.55 |
| __" Portland Cement Concrete Pavement | Gal/SY | 0.245 |
| Concrete Shoulders Adjacent to __" Pavement | Gal/SY | 0.245 |

SCHEDULE OF ESTIMATED COMPLETION PROGRESS:

(7-15-08) (Rev. 5-17-16)

108-2

SP1 G58

The Contractor's attention is directed to the Standard Special Provision entitled *Availability of Funds Termination of Contracts* included elsewhere in this proposal. The Department of Transportation's schedule of estimated completion progress for this project as required by that Standard Special Provision is as follows:

| <u>Fiscal Year</u> | | <u>Progress (% of Dollar Value)</u> |
|---------------------------|---------------------|--------------------------------------------|
| 2017 | (7/01/16 - 6/30/17) | 8% of Total Amount Bid |
| 2018 | (7/01/17 - 6/30/18) | 79% of Total Amount Bid |
| 2019 | (7/01/18 - 6/30/19) | 13% of Total Amount Bid |

The Contractor shall also furnish his own progress schedule in accordance with Article 108-2 of the *2012 Standard Specifications*. Any acceleration of the progress as shown by the Contractor's progress schedule over the progress as shown above shall be subject to the approval of the Engineer.

DISADVANTAGED BUSINESS ENTERPRISE:

(10-16-07)(Rev. 1-17-17)

102-15(J)

SP1 G61

Description

The purpose of this Special Provision is to carry out the U.S. Department of Transportation's policy of ensuring nondiscrimination in the award and administration of contracts financed in whole or in part with Federal funds. This provision is guided by 49 CFR Part 26.

Definitions

Additional DBE Subcontractors - Any DBE submitted at the time of bid that will not be used to meet the DBE goal. No submittal of a Letter of Intent is required.

Committed DBE Subcontractor - Any DBE submitted at the time of bid that is being used to meet the DBE goal by submission of a Letter of Intent. Or any DBE used as a replacement for a previously committed DBE firm.

Contract Goal Requirement - The approved DBE participation at time of award, but not greater than the advertised contract goal.

DBE Goal - A portion of the total contract, expressed as a percentage, that is to be performed by committed DBE subcontractor(s).

Disadvantaged Business Enterprise (DBE) - A firm certified as a Disadvantaged Business Enterprise through the North Carolina Unified Certification Program.

Goal Confirmation Letter - Written documentation from the Department to the bidder confirming the Contractor's approved, committed DBE participation along with a listing of the committed DBE firms.

Manufacturer - A firm that operates or maintains a factory or establishment that produces on the premises, the materials or supplies obtained by the Contractor.

Regular Dealer - A firm that owns, operates, or maintains a store, warehouse, or other establishment in which the materials or supplies required for the performance of the contract are bought, kept in stock, and regularly sold to the public in the usual course of business. A regular dealer engages in, as its principal business and in its own name, the purchase and sale or lease of the products in question. A regular dealer in such bulk items as steel, cement, gravel, stone, and petroleum products need not keep such products in stock, if it owns and operates distribution equipment for the products. Brokers and packagers are not regarded as manufacturers or regular dealers within the meaning of this section.

North Carolina Unified Certification Program (NCUCP) - A program that provides comprehensive services and information to applicants for DBE certification, such that an applicant is required to apply only once for a DBE certification that will be honored by all recipients of USDOT funds in the state and not limited to the Department of Transportation only. The Certification Program is in accordance with 49 CFR Part 26.

United States Department of Transportation (USDOT) - Federal agency responsible for issuing regulations (49 CFR Part 26) and official guidance for the DBE program.

Forms and Websites Referenced in this Provision

DBE Payment Tracking System - On-line system in which the Contractor enters the payments made to DBE subcontractors who have performed work on the project.
<https://apps.dot.state.nc.us/Vendor/PaymentTracking/>

DBE-IS Subcontractor Payment Information - Form for reporting the payments made to all DBE firms working on the project. This form is for paper bid projects only.
<https://connect.ncdot.gov/business/Turnpike/Documents/Form%20DBE-IS%20Subcontractor%20Payment%20Information.pdf>

RF-1 DBE Replacement Request Form - Form for replacing a committed DBE.

<http://connect.ncdot.gov/projects/construction/Construction%20Forms/DBE%20MBE%20WBE%20Replacement%20Request%20Form.pdf>

SAF Subcontract Approval Form - Form required for approval to sublet the contract.
<http://connect.ncdot.gov/projects/construction/Construction%20Forms/Subcontract%20Approval%20Form%20Rev.%202012.zip>

JC-1 Joint Check Notification Form - Form and procedures for joint check notification. The form acts as a written joint check agreement among the parties providing full and prompt disclosure of the expected use of joint checks.

<http://connect.ncdot.gov/projects/construction/Construction%20Forms/Joint%20Check%20Notification%20Form.pdf>

Letter of Intent - Form signed by the Contractor and the DBE subcontractor, manufacturer or regular dealer that affirms that a portion of said contract is going to be performed by the signed DBE for the amount listed at the time of bid.

<http://connect.ncdot.gov/letting/LetCentral/Letter%20of%20Intent%20to%20Perform%20as%20a%20Subcontractor.pdf>

Listing of DBE Subcontractors Form - Form for entering DBE subcontractors on a project that will meet this DBE goal. This form is for paper bids only.

[http://connect.ncdot.gov/municipalities/Bid%20Proposals%20for%20LGA%20Content/08%20DBE%20Subcontractors%20\(Federal\).docx](http://connect.ncdot.gov/municipalities/Bid%20Proposals%20for%20LGA%20Content/08%20DBE%20Subcontractors%20(Federal).docx)

Subcontractor Quote Comparison Sheet - Spreadsheet for showing all subcontractor quotes in the work areas where DBEs quoted on the project. This sheet is submitted with good faith effort packages.

<http://connect.ncdot.gov/business/SmallBusiness/Documents/DBE%20Subcontractor%20Quote%20Comparison%20Example.xls>

DBE Goal

The following DBE goal for participation by Disadvantaged Business Enterprises is established for this contract:

Disadvantaged Business Enterprises **10.0** %

- (A) *If the DBE goal is more than zero*, the Contractor shall exercise all necessary and reasonable steps to ensure that DBEs participate in at least the percent of the contract as set forth above as the DBE goal.
- (B) *If the DBE goal is zero*, the Contractor shall make an effort to recruit and use DBEs during the performance of the contract. Any DBE participation obtained shall be reported to the Department.

Directory of Transportation Firms (Directory)

Real-time information is available about firms doing business with the Department and firms that are certified through NCUCP in the Directory of Transportation Firms. Only firms identified in the Directory as DBE certified shall be used to meet the DBE goal. The Directory can be found at the following link. [https:// www.ebs.nc.gov/VendorDirectory/default.html](https://www.ebs.nc.gov/VendorDirectory/default.html)

The listing of an individual firm in the directory shall not be construed as an endorsement of the firm's capability to perform certain work.

Listing of DBE Subcontractors

At the time of bid, bidders shall submit all DBE participation that they anticipate to use during the life of the contract. Only those identified to meet the DBE goal will be considered committed, even though the listing shall include both committed DBE subcontractors and additional DBE subcontractors. Additional DBE subcontractor participation submitted at the time of bid will be used toward the Department's overall race-neutral goal. Only those firms with current DBE certification at the time of bid opening will be acceptable for listing in the bidder's submittal of DBE participation. The Contractor shall indicate the following required information:

(A) Electronic Bids

Bidders shall submit a listing of DBE participation in the appropriate section of Expedite, the bidding software of Bid Express[®].

- (1) Submit the names and addresses of DBE firms identified to participate in the contract. If the bidder uses the updated listing of DBE firms shown in Expedite, the bidder may use the dropdown menu to access the name and address of the DBE firm.
- (2) Submit the contract line numbers of work to be performed by each DBE firm. When no figures or firms are entered, the bidder will be considered to have no DBE participation.
- (3) The bidder shall be responsible for ensuring that the DBE is certified at the time of bid by checking the Directory of Transportation Firms. If the firm is not certified at the time of the bid-letting, that DBE's participation will not count towards achieving the DBE goal.

(B) Paper Bids

- (1) *If the DBE goal is more than zero,*
 - (a) Bidders, at the time the bid proposal is submitted, shall submit a listing of DBE participation, including the names and addresses on *Listing of DBE Subcontractors* contained elsewhere in the contract documents in order for

the bid to be considered responsive. Bidders shall indicate the total dollar value of the DBE participation for the contract.

- (b) If bidders have no DBE participation, they shall indicate this on the *Listing of DBE Subcontractors* by entering the word “None” or the number “0.” This form shall be completed in its entirety. **Blank forms will not be deemed to represent zero participation.** Bids submitted that do not have DBE participation indicated on the appropriate form will not be read publicly during the opening of bids. The Department will not consider these bids for award and the proposal will be rejected.
 - (c) The bidder shall be responsible for ensuring that the DBE is certified at the time of bid by checking the Directory of Transportation Firms. If the firm is not certified at the time of the bid-letting, that DBE’s participation will not count towards achieving the corresponding goal.
- (2) *If the DBE goal is zero, entries on the Listing of DBE Subcontractors are not required for the zero goal, however any DBE participation that is achieved during the project shall be reported in accordance with requirements contained elsewhere in the special provision.*

DBE Prime Contractor

When a certified DBE firm bids on a contract that contains a DBE goal, the DBE firm is responsible for meeting the goal or making good faith efforts to meet the goal, just like any other bidder. In most cases, a DBE bidder on a contract will meet the DBE goal by virtue of the work it performs on the contract with its own forces. However, all the work that is performed by the DBE bidder and any other DBE subcontractors will count toward the DBE goal. The DBE bidder shall list itself along with any DBE subcontractors, if any, in order to receive credit toward the DBE goal.

For example, if the DBE goal is 45% and the DBE bidder will only perform 40% of the contract work, the prime will list itself at 40%, and the additional 5% shall be obtained through additional DBE participation with DBE subcontractors or documented through a good faith effort.

DBE prime contractors shall also follow Sections A and B listed under *Listing of DBE Subcontractor* just as a non-DBE bidder would.

Written Documentation – Letter of Intent

The bidder shall submit written documentation for each DBE that will be used to meet the DBE goal of the contract, indicating the bidder’s commitment to use the DBE in the contract. This documentation shall be submitted on the Department’s form titled *Letter of Intent*.

The documentation shall be received in the office of the State Contractor Utilization Engineer or at DBE@ncdot.gov no later than 10:00 a.m. of the sixth calendar day following opening of bids,

unless the sixth day falls on an official state holiday. In that situation, it is due in the office of the State Contractor Utilization Engineer no later than 10:00 a.m. on the next official state business day.

If the bidder fails to submit the Letter of Intent from each committed DBE to be used toward the DBE goal, or if the form is incomplete (i.e. both signatures are not present), the DBE participation will not count toward meeting the DBE goal. If the lack of this participation drops the commitment below the DBE goal, the Contractor shall submit evidence of good faith efforts, completed in its entirety, to the State Contractor Utilization Engineer or DBE@ncdot.gov no later than 10:00 a.m. on the eighth calendar day following opening of bids, unless the eighth day falls on an official state holiday. In that situation, it is due in the office of the State Contractor Utilization Engineer no later than 10:00 a.m. on the next official state business day.

Submission of Good Faith Effort

If the bidder fails to meet or exceed the DBE goal, the apparent lowest responsive bidder shall submit to the Department documentation of adequate good faith efforts made to reach the DBE goal.

A hard copy and an electronic copy of this information shall be received in the office of the State Contractor Utilization Engineer or at DBE@ncdot.gov no later than 10:00 a.m. on the sixth calendar day following opening of bids unless the sixth day falls on an official state holiday. In that situation, it is due in the office of the State Contractor Utilization Engineer no later than 10:00 a.m. on the next official state business day. If the contractor cannot send the information electronically, then one complete set and 9 copies of this information shall be received under the same time constraints above.

Note: Where the information submitted includes repetitious solicitation letters, it will be acceptable to submit a representative letter along with a distribution list of the firms that were solicited. Documentation of DBE quotations shall be a part of the good faith effort submittal. This documentation may include written subcontractor quotations, telephone log notations of verbal quotations, or other types of quotation documentation.

Consideration of Good Faith Effort for Projects with DBE Goals More Than Zero

Adequate good faith efforts mean that the bidder took all necessary and reasonable steps to achieve the goal which, by their scope, intensity, and appropriateness, could reasonably be expected to obtain sufficient DBE participation. Adequate good faith efforts also mean that the bidder actively and aggressively sought DBE participation. Mere *pro forma* efforts are not considered good faith efforts.

The Department will consider the quality, quantity, and intensity of the different kinds of efforts a bidder has made. Listed below are examples of the types of actions a bidder will take in making a good faith effort to meet the goal and are not intended to be exclusive or exhaustive, nor is it intended to be a mandatory checklist.

- (A) Soliciting through all reasonable and available means (e.g. attendance at pre-bid meetings, advertising, written notices, use of verifiable electronic means through the use of the NCDOT Directory of Transportation Firms) the interest of all certified DBEs who have the capability to perform the work of the contract. The bidder must solicit this interest within at least 10 days prior to bid opening to allow the DBEs to respond to the solicitation. Solicitation shall provide the opportunity to DBEs within the Division and surrounding Divisions where the project is located. The bidder must determine with certainty if the DBEs are interested by taking appropriate steps to follow up initial solicitations.
- (B) Selecting portions of the work to be performed by DBEs in order to increase the likelihood that the DBE goals will be achieved.
 - (1) Where appropriate, break out contract work items into economically feasible units to facilitate DBE participation, even when the prime contractor might otherwise prefer to perform these work items with its own forces.
 - (2) Negotiate with subcontractors to assume part of the responsibility to meet the contract DBE goal when the work to be sublet includes potential for DBE participation (2nd and 3rd tier subcontractors).
- (C) Providing interested DBEs with adequate information about the plans, specifications, and requirements of the contract in a timely manner to assist them in responding to a solicitation.
- (D)
 - (1) Negotiating in good faith with interested DBEs. It is the bidder's responsibility to make a portion of the work available to DBE subcontractors and suppliers and to select those portions of the work or material needs consistent with the available DBE subcontractors and suppliers, so as to facilitate DBE participation. Evidence of such negotiation includes the names, addresses, and telephone numbers of DBEs that were considered; a description of the information provided regarding the plans and specifications for the work selected for subcontracting; and evidence as to why additional agreements could not be reached for DBEs to perform the work.
 - (2) A bidder using good business judgment would consider a number of factors in negotiating with subcontractors, including DBE subcontractors, and would take a firm's price and capabilities as well as contract goals into consideration. However, the fact that there may be some additional costs involved in finding and using DBEs is not in itself sufficient reason for a bidder's failure to meet the contract DBE goal, as long as such costs are reasonable. Also, the ability or desire of a prime contractor to perform the work of a contract with its own organization does not relieve the bidder of the responsibility to make good faith efforts. Bidding

contractors are not, however, required to accept higher quotes from DBEs if the price difference is excessive or unreasonable.

- (E) Not rejecting DBEs as being unqualified without sound reasons based on a thorough investigation of their capabilities. The bidder's standing within its industry, membership in specific groups, organizations, or associates and political or social affiliations (for example, union vs. non-union employee status) are not legitimate causes for the rejection or non-solicitation of bids in the bidder's efforts to meet the project goal.
- (F) Making efforts to assist interested DBEs in obtaining bonding, lines of credit, or insurance as required by the recipient or bidder.
- (G) Making efforts to assist interested DBEs in obtaining necessary equipment, supplies, materials, or related assistance or services.
- (H) Effectively using the services of available minority/women community organizations; minority/women contractors' groups; Federal, State, and local minority/women business assistance offices; and other organizations as allowed on a case-by-case basis to provide assistance in the recruitment and placement of DBEs. Contact within 7 days from the bid opening the Business Opportunity and Work Force Development Unit at DBE@ncdot.gov to give notification of the bidder's inability to get DBE quotes.
- (I) Any other evidence that the bidder submits which shows that the bidder has made reasonable good faith efforts to meet the DBE goal.

In addition, the Department may take into account the following:

- (1) Whether the bidder's documentation reflects a clear and realistic plan for achieving the DBE goal.
- (2) The bidders' past performance in meeting the DBE goals.
- (3) The performance of other bidders in meeting the DBE goal. For example, when the apparent successful bidder fails to meet the DBE goal, but others meet it, you may reasonably raise the question of whether, with additional reasonable efforts the apparent successful bidder could have met the goal. If the apparent successful bidder fails to meet the DBE goal, but meets or exceeds the average DBE participation obtained by other bidders, the Department may view this, in conjunction with other factors, as evidence of the apparent successful bidder having made a good faith effort.

If the Department does not award the contract to the apparent lowest responsive bidder, the Department reserves the right to award the contract to the next lowest responsive bidder that can satisfy to the Department that the DBE goal can be met or that an adequate good faith effort has been made to meet the DBE goal.

Non-Good Faith Appeal

The State Contractual Services Engineer will notify the contractor verbally and in writing of non-good faith. A contractor may appeal a determination of non-good faith made by the Goal Compliance Committee. If a contractor wishes to appeal the determination made by the Committee, they shall provide written notification to the State Contractual Services Engineer or at DBE@ncdot.gov. The appeal shall be made within 2 business days of notification of the determination of non-good faith.

Counting DBE Participation Toward Meeting DBE Goal**(A) Participation**

The total dollar value of the participation by a committed DBE will be counted toward the contract goal requirement. The total dollar value of participation by a committed DBE will be based upon the value of work actually performed by the DBE and the actual payments to DBE firms by the Contractor.

(B) Joint Checks

Prior notification of joint check use shall be required when counting DBE participation for services or purchases that involves the use of a joint check. Notification shall be through submission of Form JC-1 (*Joint Check Notification Form*) and the use of joint checks shall be in accordance with the Department's Joint Check Procedures.

(C) Subcontracts (Non-Trucking)

A DBE may enter into subcontracts. Work that a DBE subcontracts to another DBE firm may be counted toward the contract goal requirement. Work that a DBE subcontracts to a non-DBE firm does not count toward the contract goal requirement. If a DBE contractor or subcontractor subcontracts a significantly greater portion of the work of the contract than would be expected on the basis of standard industry practices, it shall be presumed that the DBE is not performing a commercially useful function. The DBE may present evidence to rebut this presumption to the Department. The Department's decision on the rebuttal of this presumption is subject to review by the Federal Highway Administration but is not administratively appealable to USDOT.

(D) Joint Venture

When a DBE performs as a participant in a joint venture, the Contractor may count toward its contract goal requirement a portion of the total value of participation with the DBE in the joint venture, that portion of the total dollar value being a distinct clearly defined portion of work that the DBE performs with its forces.

(E) Suppliers

A contractor may count toward its DBE requirement 60 percent of its expenditures for materials and supplies required to complete the contract and obtained from a DBE regular dealer and 100 percent of such expenditures from a DBE manufacturer.

(F) Manufacturers and Regular Dealers

A contractor may count toward its DBE requirement the following expenditures to DBE firms that are not manufacturers or regular dealers:

- (1) The fees or commissions charged by a DBE firm for providing a *bona fide* service, such as professional, technical, consultant, or managerial services, or for providing bonds or insurance specifically required for the performance of a DOT-assisted contract, provided the fees or commissions are determined to be reasonable and not excessive as compared with fees and commissions customarily allowed for similar services.
- (2) With respect to materials or supplies purchased from a DBE, which is neither a manufacturer nor a regular dealer, count the entire amount of fees or commissions charged for assistance in the procurement of the materials and supplies, or fees or transportation charges for the delivery of materials or supplies required on a job site (but not the cost of the materials and supplies themselves), provided the fees are determined to be reasonable and not excessive as compared with fees customarily allowed for similar services.

Commercially Useful Function

(A) DBE Utilization

The Contractor may count toward its contract goal requirement only expenditures to DBEs that perform a commercially useful function in the work of a contract. A DBE performs a commercially useful function when it is responsible for execution of the work of the contract and is carrying out its responsibilities by actually performing, managing, and supervising the work involved. To perform a commercially useful function, the DBE shall also be responsible with respect to materials and supplies used on the contract, for negotiating price, determining quality and quantity, ordering the material and installing (where applicable) and paying for the material itself. To determine whether a DBE is performing a commercially useful function, the Department will evaluate the amount of work subcontracted, industry practices, whether the amount the firm is to be paid under the contract is commensurate with the work it is actually performing and the DBE credit claimed for its performance of the work, and any other relevant factors.

(B) DBE Utilization in Trucking

The following factors will be used to determine if a DBE trucking firm is performing a commercially useful function:

- (1) The DBE shall be responsible for the management and supervision of the entire trucking operation for which it is responsible on a particular contract, and there shall not be a contrived arrangement for the purpose of meeting DBE goals.
- (2) The DBE shall itself own and operate at least one fully licensed, insured, and operational truck used on the contract.
- (3) The DBE receives credit for the total value of the transportation services it provides on the contract using trucks it owns, insures, and operates using drivers it employs.
- (4) The DBE may subcontract the work to another DBE firm, including an owner-operator who is certified as a DBE. The DBE who subcontracts work to another DBE receives credit for the total value of the transportation services the subcontracted DBE provides on the contract.
- (5) The DBE may also subcontract the work to a non-DBE firm, including from an owner-operator. The DBE who subcontracts the work to a non-DBE is entitled to credit for the total value of transportation services provided by the non-DBE subcontractor not to exceed the value of transportation services provided by DBE-owned trucks on the contract. Additional participation by non-DBE subcontractors receives credit only for the fee or commission it receives as a result of the subcontract arrangement. The value of services performed under subcontract agreements between the DBE and the Contractor will not count towards the DBE contract requirement.
- (6) A DBE may lease truck(s) from an established equipment leasing business open to the general public. The lease must indicate that the DBE has exclusive use of and control over the truck. This requirement does not preclude the leased truck from working for others during the term of the lease with the consent of the DBE, so long as the lease gives the DBE absolute priority for use of the leased truck. This type of lease may count toward the DBE's credit as long as the driver is under the DBE's payroll.
- (7) Subcontracted/leased trucks shall display clearly on the dashboard the name of the DBE that they are subcontracted/leased to and their own company name if it is not identified on the truck itself. Magnetic door signs are not permitted.

DBE Replacement

When a Contractor has relied on a commitment to a DBE firm (or an approved substitute DBE firm) to meet all or part of a contract goal requirement, the contractor shall not terminate the

DBE for convenience. This includes, but is not limited to, instances in which the Contractor seeks to perform the work of the terminated subcontractor with another DBE subcontractor, a non-DBE subcontractor, or with the Contractor's own forces or those of an affiliate. A DBE may only be terminated after receiving the Engineer's written approval based upon a finding of good cause for the termination. The prime contractor must give the DBE firm five (5) calendar days to respond to the prime contractor's notice of termination and advise the prime contractor and the Department of the reasons, if any, why the firm objects to the proposed termination of its subcontract and why the Department should not approve the action.

All requests for replacement of a committed DBE firm shall be submitted to the Engineer for approval on Form RF-1 (*DBE Replacement Request*). If the Contractor fails to follow this procedure, the Contractor may be disqualified from further bidding for a period of up to 6 months.

The Contractor shall comply with the following for replacement of a committed DBE:

(A) Performance Related Replacement

When a committed DBE is terminated for good cause as stated above, an additional DBE that was submitted at the time of bid may be used to fulfill the DBE commitment. A good faith effort will only be required for removing a committed DBE if there were no additional DBEs submitted at the time of bid to cover the same amount of work as the DBE that was terminated.

If a replacement DBE is not found that can perform at least the same amount of work as the terminated DBE, the Contractor shall submit a good faith effort documenting the steps taken. Such documentation shall include, but not be limited to, the following:

- (1) Copies of written notification to DBEs that their interest is solicited in contracting the work defaulted by the previous DBE or in subcontracting other items of work in the contract.
- (2) Efforts to negotiate with DBEs for specific subbids including, at a minimum:
 - (a) The names, addresses, and telephone numbers of DBEs who were contacted.
 - (b) A description of the information provided to DBEs regarding the plans and specifications for portions of the work to be performed.
- (3) A list of reasons why DBE quotes were not accepted.
- (4) Efforts made to assist the DBEs contacted, if needed, in obtaining bonding or insurance required by the Contractor.

(B) Decertification Replacement

- (1) When a committed DBE is decertified by the Department after the SAF (*Subcontract Approval Form*) has been received by the Department, the Department will not require the Contractor to solicit replacement DBE participation equal to the remaining work to be performed by the decertified firm. The participation equal to the remaining work performed by the decertified firm will count toward the contract goal requirement.
- (2) When a committed DBE is decertified prior to the Department receiving the SAF (*Subcontract Approval Form*) for the named DBE firm, the Contractor shall take all necessary and reasonable steps to replace the DBE subcontractor with another DBE subcontractor to perform at least the same amount of work to meet the DBE goal requirement. If a DBE firm is not found to do the same amount of work, a good faith effort must be submitted to NCDOT (see A herein for required documentation).

Changes in the Work

When the Engineer makes changes that result in the reduction or elimination of work to be performed by a committed DBE, the Contractor will not be required to seek additional participation. When the Engineer makes changes that result in additional work to be performed by a DBE based upon the Contractor's commitment, the DBE shall participate in additional work to the same extent as the DBE participated in the original contract work.

When the Engineer makes changes that result in extra work, which has more than a minimal impact on the contract amount, the Contractor shall seek additional participation by DBEs unless otherwise approved by the Engineer.

When the Engineer makes changes that result in an alteration of plans or details of construction, and a portion or all of the work had been expected to be performed by a committed DBE, the Contractor shall seek participation by DBEs unless otherwise approved by the Engineer.

When the Contractor requests changes in the work that result in the reduction or elimination of work that the Contractor committed to be performed by a DBE, the Contractor shall seek additional participation by DBEs equal to the reduced DBE participation caused by the changes.

Reports and Documentation

A SAF (*Subcontract Approval Form*) shall be submitted for all work which is to be performed by a DBE subcontractor. The Department reserves the right to require copies of actual subcontract agreements involving DBE subcontractors.

When using transportation services to meet the contract commitment, the Contractor shall submit a proposed trucking plan in addition to the SAF. The plan shall be submitted prior to beginning construction on the project. The plan shall include the names of all trucking firms proposed for

use, their certification type(s), the number of trucks owned by the firm, as well as the individual truck identification numbers, and the line item(s) being performed.

Within 30 calendar days of entering into an agreement with a DBE for materials, supplies or services, not otherwise documented by the SAF as specified above, the Contractor shall furnish the Engineer a copy of the agreement. The documentation shall also indicate the percentage (60% or 100%) of expenditures claimed for DBE credit.

Reporting Disadvantaged Business Enterprise Participation

The Contractor shall provide the Engineer with an accounting of payments made to all DBE firms, including material suppliers and contractors at all levels (prime, subcontractor, or second tier subcontractor). This accounting shall be furnished to the Engineer for any given month by the end of the following month. Failure to submit this information accordingly may result in the following action:

- (A) Withholding of money due in the next partial pay estimate; or
- (B) Removal of an approved contractor from the prequalified bidders' list or the removal of other entities from the approved subcontractors list.

While each contractor (prime, subcontractor, 2nd tier subcontractor) is responsible for accurate accounting of payments to DBEs, it shall be the prime contractor's responsibility to report all monthly and final payment information in the correct reporting manner.

Failure on the part of the Contractor to submit the required information in the time frame specified may result in the disqualification of that contractor and any affiliate companies from further bidding until the required information is submitted.

Failure on the part of any subcontractor to submit the required information in the time frame specified may result in the disqualification of that contractor and any affiliate companies from being approved for work on future DOT projects until the required information is submitted.

Contractors reporting transportation services provided by non-DBE lessees shall evaluate the value of services provided during the month of the reporting period only.

At any time, the Engineer can request written verification of subcontractor payments.

The Contractor shall report the accounting of payments through the Department's DBE Payment Tracking System.

Failure to Meet Contract Requirements

Failure to meet contract requirements in accordance with Subarticle 102-15(J) of the *2012 Standard Specifications* may be cause to disqualify the Contractor.

CERTIFICATION FOR FEDERAL-AID CONTRACTS:

(3-21-90)

SP1 G85

The prospective participant certifies, by signing and submitting this bid or proposal, to the best of his or her knowledge and belief, that:

- (A) No Federal appropriated funds have been paid or will be paid, by or on behalf of the undersigned, to any person for influencing or attempting to influence an officer or employee of any Federal agency, a Member of Congress, an officer or employee of Congress, or an employee of a Member of Congress in connection with the awarding of any Federal contract, the making of any Federal grant, the making of any Federal loan, the entering into of any cooperative agreement, and the extension, continuation, renewal, amendment, or modification of any Federal contract, grant, loan, or cooperative agreement.
- (B) If any funds other than Federal appropriated funds have been paid or will be paid to any person for influencing or attempting to influence an officer or employee of any Federal agency, a Member of Congress, an officer or employee of Congress, or an employee of a Member of Congress in connection with this Federal contract, grant, loan, or cooperative agreement, the undersigned shall complete and submit Standard Form-LLL, *Disclosure Form to Report Lobbying*, in accordance with its instructions.

This certification is a material representation of fact upon which reliance was placed when this transaction was made or entered into. Submission of this certification is a prerequisite for making or entering into this transaction imposed by *Section 1352, Title 31, U.S. Code*. Any person who fails to file the required certification shall be subject to a civil penalty of not less than \$10,000 and not more than \$100,000 for each such failure.

The prospective participant also agrees by submitting his or her bid or proposal that he or she shall require that the language of this certification be included in all lower tier subcontracts, which exceed \$100,000 and that all such subrecipients shall certify and disclose accordingly.

CONTRACTOR'S LICENSE REQUIREMENTS:

(7-1-95)

102-14

SP1 G88

If the successful bidder does not hold the proper license to perform any plumbing, heating, air conditioning, or electrical work in this contract, he will be required to sublet such work to a contractor properly licensed in accordance with *Article 2 of Chapter 87 of the General Statutes* (licensing of heating, plumbing, and air conditioning contractors) and *Article 4 of Chapter 87 of the General Statutes* (licensing of electrical contractors).

U.S. DEPARTMENT OF TRANSPORTATION HOTLINE:

(11-22-94)

108-5

SP1 G100

To report bid rigging activities call: **1-800-424-9071**

The U.S. Department of Transportation (DOT) operates the above toll-free hotline Monday through Friday, 8:00 a.m. to 5:00 p.m. eastern time. Anyone with knowledge of possible bid

rigging, bidder collusion, or other fraudulent activities should use the hotline to report such activities.

The hotline is part of the DOT's continuing effort to identify and investigate highway construction contract fraud and abuse is operated under the direction of the DOT Inspector General. All information will be treated confidentially and caller anonymity will be respected.

CARGO PREFERENCE ACT:

(2-16-16)

Privately owned United States-flag commercial vessels transporting cargoes are subject to the Cargo Preference Act (CPA) of 1954 requirements and regulations found in 46 CFR 381.7. Contractors are directed to clause (b) of 46 CFR 381.7 as follows:

- (b) Contractor and Subcontractor Clauses. "Use of United States-flag vessels: The contractor agrees-
- “(1) To utilize privately owned United States-flag commercial vessels to ship at least 50 percent of the gross tonnage (computed separately for dry bulk carriers, dry cargo liners, and tankers) involved, whenever shipping any equipment, material, or commodities pursuant to this contract, to the extent such vessels are available at fair and reasonable rates for United States-flag commercial vessels.
- (2) To furnish within 20 days following the date of loading for shipments originating within the United States or within 30 working days following the date of loading for shipments originating outside the United States a legible copy of a rated, 'on-board' commercial ocean bill-of-lading in English for each shipment of cargo described in paragraph (b) (1) of this section to both the Contracting Officer (through the prime contractor in the case of subcontractor bills-of-lading) and to the Division of National Cargo, Office of Market Development, Maritime Administration, Washington, DC 20590.
- (3) To insert the substance of the provisions of this clause in all subcontracts issued pursuant to this contract."

SUBSURFACE INFORMATION:

(7-1-95)

450

SP1 G112 D

Subsurface information is available on the roadway and structure portions of this project.

LOCATING EXISTING UNDERGROUND UTILITIES:

(3-20-12)

105

SP1 G115

Revise the 2012 *Standard Specifications* as follows:

Page 1-43, Article 105-8, line 28, after the first sentence, add the following:

Identify excavation locations by means of pre-marking with white paint, flags, or stakes or provide a specific written description of the location in the locate request.

VALUE ENGINEERING PROPOSAL:

(05-19-15)

104

SP01 G116

Revise the *2012 Standard Specifications* as follows:

Page 1-36, Subarticle 104-12(B) Evaluation of Proposals, lines 42-44, replace the fourth sentence of the second paragraph with the following:

Pending execution of a formal supplemental agreement implementing an approved VEP and transferal of final plans (hard copy and electronic) sealed by an engineer licensed in the State of North Carolina incorporating an approved VEP to the Resident Engineer and the State Value Management Engineer, the Contractor shall remain obligated to perform the work in accordance with the terms of the existing contract.

Page 1-37, Subarticle 104-12(D) Preliminary Review, lines 9-12, replace the first sentence of the first paragraph with the following:

Should the Contractor desire a preliminary review of a possible VEP, before expending considerable time and expense in full development, a copy of the Preliminary VEP shall be submitted to the Resident Engineer and the State Value Management Engineer at ValueManagementUnit@ncdot.gov.

Page 1-37, Subarticle 104-12(E) Final Proposal, lines 22-23, replace the first sentence of the first paragraph with the following:

A copy of the Final VEP shall be submitted by the Contractor to the Resident Engineer and the State Value Management Engineer at ValueManagementUnit@ncdot.gov.

Page 1-38, Subarticle 104-12(F) Modifications, lines 2-8, replace the first paragraph with the following:

To facilitate the preparation of revisions to contract drawings, the Contractor may purchase reproducible copies of drawings for his use through the Department's Value Management Unit. The preparation of new design drawings by or for the Contractor shall be coordinated with the appropriate Design Branch through the State Value Management Engineer. The Contractor shall provide, at no charge to the Department, one set of reproducible drawings of the approved design needed to implement the VEP. Drawings (hard copy and electronic) which are sealed by an engineer licensed in the State of North Carolina shall be submitted to the State Value Management Engineer no later than ten (10) business days after acceptance of a VEP unless otherwise permitted.

Page 1-38, Subarticle 104-12(F) Modifications, line 17, add the following at the end of the third paragraph:

Supplemental agreements executed for design-bid-build contracts shall reflect any realized savings in the corresponding line items. Supplemental agreements executed for design-build contracts shall add one line item deducting the full savings from the total contract price and one line item crediting the Contractor with 50% of the total VEP savings.

Page 1-38, Subarticle 104-12(F) Modifications, lines 45-47, replace the eighth paragraph with the following:

Unless and until a supplemental agreement is executed and issued by the Department and final plans (hard copy and electronic) sealed by an engineer licensed in the State of North Carolina incorporating an approved VEP have been provided to the Resident Engineer and the State Value Management Engineer, the Contractor shall remain obligated to perform the work in accordance with the terms of the existing contract.

RESOURCE CONSERVATION AND ENV. SUSTAINABLE PRACTICES:

(5-21-13) (Rev. 5-19-15)

104-13

SP1 G118

In accordance with North Carolina Executive Order 156, NCGS 130A-309.14(3), and NCGS 136-28.8, it is the objective of the Department to aid in the reduction of materials that become a part of our solid waste stream, to divert materials from landfills, to find ways to recycle and reuse materials, to consider and minimize, where economically feasible, the environmental impacts associated with agency land use and acquisition, construction, maintenance and facility management for the benefit of the Citizens of North Carolina.

To achieve the mission of reducing environmental impacts across the state, the Department is committed to supporting the efforts to initiate, develop and use products and construction methods that incorporate the use of recycled, solid waste products and environmentally sustainable practices in accordance with Article 104-13 of the *Standard Specifications*.

Report the quantities of reused or recycled materials either incorporated in the project or diverted from landfills and any practice that minimizes the environmental impact on the project annually on the Project Construction Reuse and Recycling Reporting Form. The Project Construction Reuse and Recycling Reporting Form and a location tool for local recycling facilities are available at:

<http://connect.ncdot.gov/resources/Environmental/Pages/North-Carolina-Recycling-Locations.aspx>.

Submit the Project Construction Reuse and Recycling Reporting Form by August 1 annually to valuemanagementunit@ncdot.gov. For questions regarding the form or reporting, please contact the State Value Management Engineer at 919-707-4810.

DOMESTIC STEEL:

(4-16-13)

106

SP1 G120

Revise the 2012 *Standard Specifications* as follows:

Page 1-49, Subarticle 106-1(B) Domestic Steel, lines 2-7, replace the first paragraph with the following:

All steel and iron products that are permanently incorporated into this project shall be produced in the United States except minimal amounts of foreign steel and iron products may be used provided the combined material cost of the items involved does not exceed 0.1% of the total amount bid for

the entire project or \$2,500, whichever is greater. If invoices showing the cost of the material are not provided, the amount of the bid item involving the foreign material will be used for calculations. This minimal amount of foreign produced steel and iron products permitted for use is not applicable to high strength fasteners. Domestically produced high strength fasteners are required.

MAINTENANCE OF THE PROJECT:

(11-20-07) (Rev. 1-17-12)

104-10

SP1 G125

Revise the *2012 Standard Specifications* as follows:

Page 1-35, Article 104-10 Maintenance of the Project, line 25, add the following after the first sentence of the first paragraph:

All guardrail/guiderail within the project limits shall be included in this maintenance.

Page 1-35, Article 104-10 Maintenance of the Project, line 30, add the following as the last sentence of the first paragraph:

The Contractor shall perform weekly inspections of guardrail and guiderail and shall report damages to the Engineer on the same day of the weekly inspection. *Where damaged guardrail or guiderail is repaired or replaced as a result of maintaining the project in accordance with this article, such repair or replacement shall be performed within 7 consecutive calendar days of such inspection report.*

Page 1-35, Article 104-10 Maintenance of the Project, lines 42-44, replace the last sentence of the last paragraph with the following:

The Contractor will not be directly compensated for any maintenance operations necessary, except for maintenance of guardrail/guiderail, as this work will be considered incidental to the work covered by the various contract items. The provisions of Article 104-7, Extra Work, and Article 104-8, Compensation and Record Keeping will apply to authorized maintenance of guardrail/guiderail. Performance of weekly inspections of guardrail/guiderail, and the damage reports required as described above, will be considered to be an incidental part of the work being paid for by the various contract items.

COOPERATION BETWEEN CONTRACTORS:

(7-1-95)

105-7

SP1 G133

The Contractor's attention is directed to Article 105-7 of the *2012 Standard Specifications*.

R-2559 / R-3329 (C202587) is currently under construction adjacent to the limits of this project and will not be completed prior to the letting of this project.

The Contractor on this project shall cooperate with the Contractor working within or adjacent to the limits of this project to the extent that the work can be carried out to the best advantage of all concerned.

TWELVE MONTH GUARANTEE:

(7-15-03)

108

SP1 G145

- (A) The Contractor shall guarantee materials and workmanship against latent and patent defects arising from faulty materials, faulty workmanship or negligence for a period of twelve months following the date of final acceptance of the work for maintenance and shall replace such defective materials and workmanship without cost to the Department. The Contractor will not be responsible for damage due to faulty design, normal wear and tear, for negligence on the part of the Department, and/or for use in excess of the design.
- (B) Where items of equipment or material carry a manufacturer's guarantee for any period in excess of twelve months, then the manufacturer's guarantee shall apply for that particular piece of equipment or material. The Department's first remedy shall be through the manufacturer although the Contractor is responsible for invoking the warranted repair work with the manufacturer. The Contractor's responsibility shall be limited to the term of the manufacturer's guarantee. NCDOT would be afforded the same warranty as provided by the Manufacturer.

This guarantee provision shall be invoked only for major components of work in which the Contractor would be wholly responsible for under the terms of the contract. Examples would include pavement structures, bridge components, and sign structures. This provision will not be used as a mechanism to force the Contractor to return to the project to make repairs or perform additional work that the Department would normally compensate the Contractor for. In addition, routine maintenance activities (i.e. mowing grass, debris removal, ruts in earth shoulders,) are not parts of this guarantee.

Appropriate provisions of the payment and/or performance bonds shall cover this guarantee for the project.

To ensure uniform application statewide the Division Engineer will forward details regarding the circumstances surrounding any proposed guarantee repairs to the Chief Engineer for review and approval prior to the work being performed.

IRAN DIVESTMENT ACT:

(5-17-16)

SP01 G151

As a result of the Iran Divestment Act of 2015 (Act), Article 6E, N.C. General Statute § 147-86.55, the State Treasurer published the Final Divestment List (List) which includes the Final Divestment List-Iran, and the Parent and Subsidiary Guidance-Iran. These lists identify companies and persons engaged in investment activities in Iran and will be updated every 180 days. The List can be found at <https://www.nctreasurer.com/inside-the-department/OpenGovernment/Pages/Iran-Divestment-Act-Resources.aspx>

By submitting the Offer, the Contractor certifies that, as of the date of this bid, it is not on the then-current List created by the State Treasurer. The Contractor must notify the Department immediately if, at any time before the award of the contract, it is added to the List.

As an ongoing obligation, the Contractor must notify the Department immediately if, at any time during the contract term, it is added to the List. Consistent with § 147-86.59, the Contractor shall not contract with any person to perform a part of the work if, at the time the subcontract is signed, that person is on the then-current List.

During the term of the Contract, should the Department receive information that a person is in violation of the Act as stated above, the Department will offer the person an opportunity to respond and the Department will take action as appropriate and provided for by law, rule, or contract.

GIFTS FROM VENDORS AND CONTRACTORS:

(12-15-09)

107-1

SP1 G152

By Executive Order 24, issued by Governor Perdue, and *N.C.G.S. § 133-32*, it is unlawful for any vendor or contractor (i.e. architect, bidder, contractor, construction manager, design professional, engineer, landlord, offeror, seller, subcontractor, supplier, or vendor), to make gifts or to give favors to any State employee of the Governor's Cabinet Agencies (i.e. Administration, Commerce, Correction, Crime Control and Public Safety, Cultural Resources, Environment and Natural Resources, Health and Human Services, Juvenile Justice and Delinquency Prevention, Revenue, Transportation, and the Office of the Governor). This prohibition covers those vendors and contractors who:

- (A) Have a contract with a governmental agency; or
- (B) Have performed under such a contract within the past year; or
- (C) Anticipate bidding on such a contract in the future.

For additional information regarding the specific requirements and exemptions, vendors and contractors are encouraged to review Executive Order 24 and *N.C.G.S. § 133-32*.

Executive Order 24 also encouraged and invited other State Agencies to implement the requirements and prohibitions of the Executive Order to their agencies. Vendors and contractors should contact other State Agencies to determine if those agencies have adopted Executive Order 24.

LIABILITY INSURANCE:

(5-20-14)

SP1 G160

Revise the *2012 Standard Specifications* as follows:

Page 1-60, Article 107-15 LIABILITY INSURANCE, line 16, add the following as the second sentence of the third paragraph:

Prior to beginning services, all contractors shall provide proof of coverage issued by a workers' compensation insurance carrier, or a certificate of compliance issued by the Department of Insurance for self-insured subcontractors, irrespective of whether having regularly in service fewer than three employees.

EROSION AND SEDIMENT CONTROL/STORMWATER CERTIFICATION:

(1-16-07) (Rev 11-22-16)

105-16, 225-2, 16

SPI G180

General

Schedule and conduct construction activities in a manner that will minimize soil erosion and the resulting sedimentation and turbidity of surface waters. Comply with the requirements herein regardless of whether or not a National Pollution discharge Elimination System (NPDES) permit for the work is required.

Establish a chain of responsibility for operations and subcontractors' operations to ensure that the *Erosion and Sediment Control/Stormwater Pollution Prevention Plan* is implemented and maintained over the life of the contract.

- (A) *Certified Supervisor* - Provide a certified Erosion and Sediment Control/Stormwater Supervisor to manage the Contractor and subcontractor operations, insure compliance with Federal, State and Local ordinances and regulations, and manage the Quality Control Program.
- (B) *Certified Foreman* - Provide a certified, trained foreman for each construction operation that increases the potential for soil erosion or the possible sedimentation and turbidity of surface waters.
- (C) *Certified Installer* - Provide a certified installer to install or direct the installation for erosion or sediment/stormwater control practices.
- (D) *Certified Designer* - Provide a certified designer for the design of the erosion and sediment control/stormwater component of reclamation plans and, if applicable, for the design of the project erosion and sediment control/stormwater plan.

Roles and Responsibilities

- (A) *Certified Erosion and Sediment Control/Stormwater Supervisor* - The Certified Supervisor shall be Level II and responsible for ensuring the erosion and sediment control/stormwater plan is adequately implemented and maintained on the project and for conducting the quality control program. The Certified Supervisor shall be on the project within 24 hours' notice from initial exposure of an erodible surface to the project's final acceptance. Perform the following duties:
 - (1) **Manage Operations** - Coordinate and schedule the work of subcontractors so that erosion and sediment control/stormwater measures are fully executed for each operation and in a timely manner over the duration of the contract.
 - (a) Oversee the work of subcontractors so that appropriate erosion and sediment control/stormwater preventive measures are conformed to at each stage of the work.

- (b) Prepare the required National Pollutant Discharge Elimination System (NPDES) Inspection Record and submit to the Engineer.
 - (c) Attend all weekly or monthly construction meetings to discuss the findings of the NPDES inspection and other related issues.
 - (d) Implement the erosion and sediment control/stormwater site plans requested.
 - (e) Provide any needed erosion and sediment control/stormwater practices for the Contractor's temporary work not shown on the plans, such as, but not limited to work platforms, temporary construction, pumping operations, plant and storage yards, and cofferdams.
 - (f) Acquire applicable permits and comply with requirements for borrow pits, dewatering, and any temporary work conducted by the Contractor in jurisdictional areas.
 - (g) Conduct all erosion and sediment control/stormwater work in a timely and workmanlike manner.
 - (h) Fully perform and install erosion and sediment control/stormwater work prior to any suspension of the work.
 - (i) Coordinate with Department, Federal, State and Local Regulatory agencies on resolution of erosion and sediment control/stormwater issues due to the Contractor's operations.
 - (j) Ensure that proper cleanup occurs from vehicle tracking on paved surfaces or any location where sediment leaves the Right-of-Way.
 - (k) Have available a set of erosion and sediment control/stormwater plans that are initialed and include the installation date of Best Management Practices. These practices shall include temporary and permanent groundcover and be properly updated to reflect necessary plan and field changes for use and review by Department personnel as well as regulatory agencies.
- (2) Requirements set forth under the NPDES Permit - The Department's NPDES Stormwater permit (NCS000250) outlines certain objectives and management measures pertaining to construction activities. The permit references *NCG010000, General Permit to Discharge Stormwater* under the NPDES, and states that the Department shall incorporate the applicable requirements into its delegated Erosion and Sediment Control Program for construction activities disturbing one or more acres of land. The Department further incorporates these requirements on all contracted bridge and culvert work at jurisdictional waters, regardless of size. Some of the requirements are, but are not limited to:
- (a) Control project site waste to prevent contamination of surface or ground waters of the state, i.e. from equipment operation/maintenance, construction materials, concrete washout, chemicals, litter, fuels, lubricants, coolants, hydraulic fluids, any other petroleum products, and sanitary waste.
 - (b) Inspect erosion and sediment control/stormwater devices and stormwater discharge outfalls at least once every 7 calendar days and within 24 hours after a rainfall event of 0.5 inch that occurs within a 24 hour period. Additional monitoring may be required at the discretion of Division of

- Water Resources personnel if the receiving stream is 303(d) listed for turbidity and the project has had documented problems managing turbidity.
- (c) Maintain an onsite rain gauge or use the Department's Multi-Sensor Precipitation Estimate website to maintain a daily record of rainfall amounts and dates.
 - (d) Maintain erosion and sediment control/stormwater inspection records for review by Department and Regulatory personnel upon request.
 - (e) Implement approved reclamation plans on all borrow pits, waste sites and staging areas.
 - (f) Maintain a log of turbidity test results as outlined in the Department's Procedure for Monitoring Borrow Pit Discharge.
 - (g) Provide secondary containment for bulk storage of liquid materials.
 - (h) Provide training for employees concerning general erosion and sediment control/stormwater awareness, the Department's NPDES Stormwater Permit NCS000250 requirements, and the applicable requirements of the *General Permit, NCG010000*.
 - (i) Report violations of the NPDES permit to the Engineer immediately who will notify the Division of Water Quality Regional Office within 24 hours of becoming aware of the violation.
- (3) Quality Control Program - Maintain a quality control program to control erosion, prevent sedimentation and follow provisions/conditions of permits. The quality control program shall:
- (a) Follow permit requirements related to the Contractor and subcontractors' construction activities.
 - (b) Ensure that all operators and subcontractors on site have the proper erosion and sediment control/stormwater certification.
 - (c) Notify the Engineer when the required certified erosion and sediment control/stormwater personnel are not available on the job site when needed.
 - (d) Conduct the inspections required by the NPDES permit.
 - (e) Take corrective actions in the proper timeframe as required by the NPDES permit for problem areas identified during the NPDES inspections.
 - (f) Incorporate erosion control into the work in a timely manner and stabilize disturbed areas with mulch/seed or vegetative cover on a section-by-section basis.
 - (g) Use flocculants approved by state regulatory authorities where appropriate and where required for turbidity and sedimentation reduction.
 - (h) Ensure proper installation and maintenance of temporary erosion and sediment control devices.
 - (i) Remove temporary erosion or sediment control devices when they are no longer necessary as agreed upon by the Engineer.
 - (j) The Contractor's quality control and inspection procedures shall be subject to review by the Engineer. Maintain NPDES inspection records and make records available at all times for verification by the Engineer.

(B) *Certified Foreman* - At least one Certified Foreman shall be onsite for each type of work listed herein during the respective construction activities to control erosion, prevent sedimentation and follow permit provisions:

- (1) Foreman in charge of grading activities
- (2) Foreman in charge of bridge or culvert construction over jurisdictional areas
- (3) Foreman in charge of utility activities

The Contractor may request to use the same person as the Level II Supervisor and Level II Foreman. This person shall be onsite whenever construction activities as described above are taking place. This request shall be approved by the Engineer prior to work beginning. The Contractor may request to name a single Level II Foreman to oversee multiple construction activities on small bridge or culvert replacement projects. This request shall be approved by the Engineer prior to work beginning.

(C) *Certified Installers* - Provide at least one onsite, Level I Certified Installer for each of the following erosion and sediment control/stormwater crew:

- (1) Seeding and Mulching
- (2) Temporary Seeding
- (3) Temporary Mulching
- (4) Sodding
- (5) Silt fence or other perimeter erosion/sediment control device installations
- (6) Erosion control blanket installation
- (7) Hydraulic tackifier installation
- (8) Turbidity curtain installation
- (9) Rock ditch check/sediment dam installation
- (10) Ditch liner/matting installation
- (11) Inlet protection
- (12) Riprap placement
- (13) Stormwater BMP installations (such as but not limited to level spreaders, retention/detention devices)
- (14) Pipe installations within jurisdictional areas

If a Level I *Certified Installer* is not onsite, the Contractor may substitute a Level II Foreman for a Level I Installer, provided the Level II Foreman is not tasked to another crew requiring Level II Foreman oversight.

(D) *Certified Designer* - Include the certification number of the Level III-B Certified Designer on the erosion and sediment control/stormwater component of all reclamation plans and if applicable, the certification number of the Level III-A Certified Designer on the design of the project erosion and sediment control/stormwater plan.

Preconstruction Meeting

Furnish the names of the *Certified Erosion and Sediment Control/Stormwater Supervisor*, *Certified Foremen*, *Certified Installers* and *Certified Designer* and notify the Engineer of changes in certified personnel over the life of the contract within 2 days of change.

Ethical Responsibility

Any company performing work for the North Carolina Department of Transportation has the ethical responsibility to fully disclose any reprimand or dismissal of an employee resulting from improper testing or falsification of records.

Revocation or Suspension of Certification

Upon recommendation of the Chief Engineer to the certification entity, certification for *Supervisor*, *Certified Foremen*, *Certified Installers* and *Certified Designer* may be revoked or suspended with the issuance of an *Immediate Corrective Action (ICA)*, *Notice of Violation (NOV)*, or *Cease and Desist Order* for erosion and sediment control/stormwater related issues.

The Chief Engineer may recommend suspension or permanent revocation of certification due to the following:

- (A) Failure to adequately perform the duties as defined within this certification provision.
- (B) Issuance of an ICA, NOV, or Cease and Desist Order.
- (C) Failure to fully perform environmental commitments as detailed within the permit conditions and specifications.
- (D) Demonstration of erroneous documentation or reporting techniques.
- (E) Cheating or copying another candidate's work on an examination.
- (F) Intentional falsification of records.
- (G) Directing a subordinate under direct or indirect supervision to perform any of the above actions.
- (H) Dismissal from a company for any of the above reasons.
- (I) Suspension or revocation of one's certification by another entity.

Suspension or revocation of a certification will be sent by certified mail to the certificant and the Corporate Head of the company that employs the certificant.

A certificant has the right to appeal any adverse action which results in suspension or permanent revocation of certification by responding, in writing, to the Chief Engineer within 10 calendar days after receiving notice of the proposed adverse action.

Chief Engineer
1536 Mail Service Center
Raleigh, NC 27699-1536

Failure to appeal within 10 calendar days will result in the proposed adverse action becoming effective on the date specified on the certified notice. Failure to appeal within the time specified will result in a waiver of all future appeal rights regarding the adverse action taken. The certificant will not be allowed to perform duties associated with the certification during the appeal process.

The Chief Engineer will hear the appeal and make a decision within 7 days of hearing the appeal. Decision of the Chief Engineer will be final and will be made in writing to the certificant.

If a certification is temporarily suspended, the certificant shall pass any applicable written examination and any proficiency examination, at the conclusion of the specified suspension period, prior to having the certification reinstated.

Measurement and Payment

Certified Erosion and Sediment Control/Stormwater Supervisor, Certified Foremen, Certified Installers and Certified Designer will be incidental to the project for which no direct compensation will be made.

PROCEDURE FOR MONITORING BORROW PIT DISCHARGE:

(2-20-07) (Rev. 3-19-13)

105-16, 230, 801

SP1 G181

Water discharge from borrow pit sites shall not cause surface waters to exceed 50 NTUs (nephelometric turbidity unit) in streams not designated as trout waters and 10 NTUs in streams, lakes or reservoirs designated as trout waters. For lakes and reservoirs not designated as trout waters, the turbidity shall not exceed 25 NTUs. If the turbidity exceeds these levels due to natural background conditions, the existing turbidity level shall not be increased.

If during any operating day, the downstream water quality exceeds the standard, the Contractor shall do all of the following:

- (A) Either cease discharge or modify the discharge volume or turbidity levels to bring the downstream turbidity levels into compliance, or
- (B) Evaluate the upstream conditions to determine if the exceedance of the standard is due to natural background conditions. If the background turbidity measurements exceed the standard, operation of the pit and discharge can continue as long as the stream turbidity levels are not increased due to the discharge.
- (C) Measure and record the turbidity test results (time, date and sampler) at all defined sampling locations 30 minutes after startup and at a minimum, one additional sampling of all sampling locations during that 24-hour period in which the borrow pit is discharging.
- (D) Notify DWQ within 24 hours of any stream turbidity standard exceedances that are not brought into compliance.

During the Environmental Assessment required by Article 230-4 of the *2012 Standard Specifications*, the Contractor shall define the point at which the discharge enters into the State's

surface waters and the appropriate sampling locations. Sampling locations shall include points upstream and downstream from the point at which the discharge enters these waters. Upstream sampling location shall be located so that it is not influenced by backwater conditions and represents natural background conditions. Downstream sampling location shall be located at the point where complete mixing of the discharge and receiving water has occurred.

The discharge shall be closely monitored when water from the dewatering activities is introduced into jurisdictional wetlands. Any time visible sedimentation (deposition of sediment) on the wetland surface is observed, the dewatering activity will be suspended until turbidity levels in the stilling basin can be reduced to a level where sediment deposition does not occur. Staining of wetland surfaces from suspended clay particles, occurring after evaporation or infiltration, does not constitute sedimentation. No activities shall occur in wetlands that adversely affect the functioning of a wetland. Visible sedimentation will be considered an indication of possible adverse impacts on wetland use.

The Engineer will perform independent turbidity tests on a random basis. These results will be maintained in a log within the project records. Records will include, at a minimum, turbidity test results, time, date and name of sampler. Should the Department's test results exceed those of the Contractor's test results, an immediate test shall be performed jointly with the results superseding the previous test results of both the Department and the Contractor.

The Contractor shall use the *NCDOT Turbidity Reduction Options for Borrow Pits Matrix*, available at http://www.ncdot.gov/doh/operations/dp_chief_eng/roadside/fieldops/downloads/Files/TurbidityReductionOptionSheet.pdf to plan, design, construct, and maintain BMPs to address water quality standards. Tier I Methods include stilling basins which are standard compensatory BMPs. Other Tier I methods are noncompensatory and shall be used when needed to meet the stream turbidity standards. Tier II Methods are also noncompensatory and are options that may be needed for protection of rare or unique resources or where special environmental conditions exist at the site which have led to additional requirements being placed in the DWQ's 401 Certifications and approval letters, Isolated Wetland Permits, Riparian Buffer Authorization or a DOT Reclamation Plan's Environmental Assessment for the specific site. Should the Contractor exhaust all Tier I Methods on a site exclusive of rare or unique resources or special environmental conditions, Tier II Methods may be required by regulators on a case by case basis per supplemental agreement.

The Contractor may use cation exchange capacity (CEC) values from proposed site borings to plan and develop the bid for the project. CEC values exceeding 15 milliequivalents per 100 grams of soil may indicate a high potential for turbidity and should be avoided when dewatering into surface water is proposed.

No additional compensation for monitoring borrow pit discharge will be paid.

EMPLOYMENT:

(11-15-11) (Rev. 1-17-12)

108, 102

SP1 G184

Revise the *2012 Standard Specifications* as follows:

Page 1-20, Subarticle 102-15(O), delete and replace with the following:

(O) Failure to restrict a former Department employee as prohibited by Article 108-5.

Page 1-65, Article 108-5 Character of Workmen, Methods, and Equipment, line 32, delete all of line 32, the first sentence of the second paragraph and the first word of the second sentence of the second paragraph.

STATE HIGHWAY ADMINISTRATOR TITLE CHANGE:

(9-18-12)

SP1 G185

Revise the *2012 Standard Specifications* as follows:

Replace all references to “State Highway Administrator” with “Chief Engineer”.

SUBLETTING OF CONTRACT:

(11-18-2014)

108-6

SP1 G186

Revise the *2012 Standard Specifications* as follows:

Page 1-66, Article 108-6 Subletting of Contract, line 37, add the following as the second sentence of the first paragraph:

All requests to sublet work shall be submitted within 30 days of the date of availability or prior to expiration of 20% of the contract time, whichever date is later, unless otherwise approved by the Engineer.

Page 1-67, Article 108-6 Subletting of Contract, line 7, add the following as the second sentence of the fourth paragraph:

Purchasing materials for subcontractors is not included in the percentage of work required to be performed by the Contractor. If the Contractor sublets items of work but elects to purchase material for the subcontractor, the value of the material purchased will be included in the total dollar amount considered to have been sublet.

PROJECT SPECIAL PROVISIONS**ROADWAY****CLEARING AND GRUBBING - METHOD II:**

(9-17-02) (Rev.8-18-15)

200

SP2 R02A

Perform clearing on this project to the limits established by Method "II" shown on Standard Drawing No. 200.02 of the *2012 Roadway Standard Drawings*. Conventional clearing methods may be used except where permit drawings or conditions have been included in the proposal which require certain areas to be cleared by hand methods.

BURNING RESTRICTIONS:

(7-1-95)

200, 210, 215

SP2 R05

Open burning is not permitted on any portion of the right-of-way limits established for this project. Do not burn the clearing, grubbing or demolition debris designated for disposal and generated from the project at locations within the project limits, off the project limits or at any waste or borrow sites in this county. Dispose of the clearing, grubbing and demolition debris by means other than burning, according to state or local rules and regulations.

SHOULDER AND FILL SLOPE MATERIAL:

(5-21-02)

235, 560

SP2 R45 A

Description

Perform the required shoulder and slope construction for this project in accordance with the applicable requirements of Section 560 and Section 235 of the *2012 Standard Specifications*.

Measurement and Payment

Where the material has been obtained from an authorized stockpile or from a borrow source and *Borrow Excavation* is not included in the contract, no direct payment will be made for this work, as the cost of this work will be part of the work being paid at the contract lump sum price for *Grading*. If *Borrow Excavation* is included in this contract and the material has been obtained from an authorized stockpile or from a borrow source, measurement and payment will be as provided in Section 230 of the *2012 Standard Specifications* for *Borrow Excavation*.

ROCK AND BROKEN PAVEMENT FILLS:

(2-16-16)

235

SP2 R85

Revise the *2012 Standard Specifications* as follows:

Page 2-22, Article 235-2 MATERIALS, add the following after line 19:

Item

Geotextile for Rock and Broken Pavement Fills, Type 2

Section

1056

Provide Type 2 geotextile for filtration geotextiles. Use rip rap and No. 57 stone from either a quarry or onsite material to fill voids in rock and broken pavement fills. Provide small and large size rip rap with stone sizes that meet Class A and B in accordance with Table 1042-1 and No. 57 stone with a gradation that meets Table 1005-1 or use similar size onsite material approved by the Engineer.

Page 2-23, Subarticle 235-3(B) Embankment Formation, lines 18-19, delete the third sentence in the seventh paragraph.

Page 2-23, Subarticle 235-3(B) Embankment Formation, lines 21-23, replace the eighth paragraph with the following:

Before placing embankment fill material or filtration geotextiles over rock and broken pavement, fill voids in the top of rock and broken pavement fill with rip rap and No. 57 stone. Place and compact larger rip rap first followed by smaller rip rap. Then, fill any remaining voids with No. 57 stone so geotextiles are not torn, ripped or otherwise damaged when installed and covered. Compact rip rap and No. 57 stone with tracked equipment or other approved methods. Install filtration geotextiles on top of rock, broken pavement, rip rap and No. 57 stone in accordance with Article 270-3 before placing remaining embankment fill material.

Remove any rocks, debris or pavement pieces from the roadbed larger than 2" within 12" of the subgrade or finished grade, whichever is lower.

Page 2-24, Article 235-5 MEASUREMENT AND PAYMENT, line 13, add the following to the end of the first paragraph:

Payment for rip rap, No. 57 stone and geotextiles to construct embankments with rock and broken pavement fills will be considered incidental to the work in Sections 225, 226, 230 and 240.

BLASTING:

(2-16-16)

220

SP2 R88B

Revise the *2012 Standard Specifications* as follows:

Page 2-8, Article 220-1 DESCRIPTION, line 22, delete "cushion, ".

Page 2-8, Article 220-1 DESCRIPTION, line 23, add the following after the third sentence:

Unless required otherwise in the contract, design blasts for the vibration and air overpressure limits in this section.

Page 2-9, Subarticle 220-3(A) Vibration and Air Overpressure Limits, line 18, add the following to the end of Subarticle 220-3(A):

Unless required otherwise in the contract or directed, design production and trench blasts in accordance with the following:

- (1) Production Blasting
- (a) For rock cut slopes steeper than 1.5:1 (H:V) without pre-splitting, do not use production blast holes more than 4" in diameter within 10 ft of finished slope faces or neat lines
 - (b) Do not drill production holes below bottom of adjacent pre-split blast holes
 - (c) Use delay blasting to detonate production blast holes towards a free face
- (2) Trench Blasting
- (a) Do not use trench blast holes more than 3" in diameter
 - (b) Do not use ANFO or other bulk loaded products
 - (c) Use cartridge explosives or other explosive types designed for trench blasting
 - (d) Use charges with a diameter of 1/2" to 3/4" less than the trench blast hole diameter

PIPE INSTALLATION:

(11-20-12) (Rev. 8-18-15)

300

SP3 R01

Revise the *2012 Standard Specifications* as follows:

Page 3-1, Article 300-2, Materials, line 15, in the materials table, replace “Flowable Fill” and “Geotextiles” with the following:

| Item | Section |
|----------------------------|----------------|
| Flowable Fill, Excavatable | 1000-6 |
| Grout, Type 2 | 1003 |
| Geotextiles, Type 4 | 1056 |

Page 3-1, Article 300-2, Materials, lines 23-24, replace sentence with the following:

Provide foundation conditioning geotextile and geotextile to wrap pipe joints in accordance with Section 1056 for Type 4 geotextile.

Page 3-3, Subarticle 300-6(A), Rigid Pipe, line 2, in the first paragraph, replace “an approved non-shrink grout.” with “grout.” and line 4, in the second paragraph, replace “filtration geotextile” with “geotextile”.

Page 3-3, Article 300-7, Backfilling, lines 37-38, in the first and second sentences of the fifth paragraph, replace “Excavatable flowable fill” with “Flowable fill”.

FLOWABLE FILL:

(9-17-02) (Rev 1-17-12)

300, 340, 1000, 1530, 1540, 1550

SP3 R30

Description

This work consists of all work necessary to place flowable fill in accordance with these provisions, the plans, and as directed.

Materials

Refer to Division 10 of the *2012 Standard Specifications*.

Item

Flowable Fill

Section

1000-6

Construction Methods

Discharge flowable fill material directly from the truck into the space to be filled, or by other approved methods. The mix may be placed full depth or in lifts as site conditions dictate. The Contractor shall provide a method to plug the ends of the existing pipe in order to contain the flowable fill.

Measurement and Payment

At locations where flowable fill is called for on the plans and a pay item for flowable fill is included in the contract, *Flowable Fill* will be measured in cubic yards and paid as the actual number of cubic yards that have been satisfactorily placed and accepted. Such price and payment will be full compensation for all work covered by this provision including, but not limited to, the mix design, furnishing, hauling, placing and containing the flowable fill.

Payment will be made under:

Pay Item

Flowable Fill

Pay Unit

Cubic Yard

ASPHALT PAVEMENTS - SUPERPAVE:

(6-19-12) (Rev. 8-16-16)

605, 609, 610, 650

SP6 R01

Revise the *2012 Standard Specifications* as follows:

Page 6-3, Article 605-7, APPLICATION RATES AND TEMPERATURES, replace this article, including Table 605-1, with the following:

Apply tack coat uniformly across the existing surface at target application rates shown in Table 605-1.

| TABLE 605-1 APPLICATION RATES FOR TACK COAT | |
|--------------------------------------------------------|-----------------------------|
| Existing Surface | Target Rate (gal/sy) |
| | Emulsified Asphalt |
| New Asphalt | 0.04 ± 0.01 |
| Oxidized or Milled Asphalt | 0.06 ± 0.01 |
| Concrete | 0.08 ± 0.01 |

Apply tack coat at a temperature within the ranges shown in Table 605-2. Tack coat shall not be overheated during storage, transport or at application.

| TABLE 605-2 APPLICATION TEMPERATURE FOR TACK COAT | |
|--------------------------------------------------------------|--------------------------|
| Asphalt Material | Temperature Range |
| Asphalt Binder, Grade PG 64-22 | 350 - 400°F |
| Emulsified Asphalt, Grade RS-1H | 130 - 160°F |
| Emulsified Asphalt, Grade CRS-1 | 130 - 160°F |
| Emulsified Asphalt, Grade CRS-1H | 130 - 160°F |
| Emulsified Asphalt, Grade HFMS-1 | 130 - 160°F |
| Emulsified Asphalt, Grade CRS-2 | 130 - 160°F |

Page 6-6, Subarticle 607-5(A), Milled Asphalt Pavement, line 25, add the following to the end of the paragraph:

Areas to be paid under these items include mainline, turn lanes, shoulders, and other areas milled in conjunction with the mainline and any additional equipment necessary to remove pavement in the area of manholes, water valves, curb, gutter and other obstructions.

Page 6-6, Subarticle 607-5(C), Incidental Milling, lines 42-48, replace the paragraph with the following:

Incidental Milling to be paid will be the actual number of square yards of surface milled where the Contractor is required to mill butt joints, irregular areas and intersections milled as a separate operation from mainline milling and re-mill areas that are not due to the Contractor's negligence whose length is less than 100 feet. Measurement will be made as provided in Subarticle 607-5(A) for each cut the Contractor is directed to perform. Where the Contractor elects to make multiple cuts to achieve the final depth, no additional measurement will be made. Compensation will be made at the contract unit price per square yard for *Incidental Milling*.

Page 6-7, Article 609-3, FIELD VERIFICATION OF MIXTURE AND JOB MIX FORMULA ADJUSTMENTS, lines 35-37, delete the second sentence of the second paragraph.

Page 6-18, Article 610-1 DESCRIPTION, lines 40-41, delete the last sentence of the last paragraph.

Page 6-19, Subarticle 610-3(A), Mix Design-General, line 5, add the following as the first paragraph:

Warm mix asphalt (WMA) is allowed for use at the Contractor's option in accordance with the NCDOT Approved Products List for WMA Technologies available at:

<https://connect.ncdot.gov/resources/Materials/MaterialsResources/Warm%20Mix%20Asphalt%20Approved%20List.pdf>

Page 6-20, Subarticle 610-3(C), Job Mix Formula (JMF), lines 47-48, replace the last sentence of the third paragraph with the following:

The JMF mix temperature shall be within the ranges shown in Table 610-1 unless otherwise approved.

Page 6-21, Subarticle 610-3(C) Job Mix Formula (JMF), replace Table 610-1 with the following:

| TABLE 610-1 | |
|------------------------------------------------|----------------------------|
| MIXING TEMPERATURE AT THE ASPHALT PLANT | |
| Binder Grade | JMF Mix Temperature |
| PG 58-28; PG 64-22 | 250 - 290°F |
| PG 70-22 | 275- 305°F |
| PG 76-22 | 300- 325°F |

Page 6-21, Subarticle 610-3(C) Job Mix Formula (JMF), lines 1-2, in the first sentence of the first paragraph, delete “and compaction”. Lines 4-7, delete the second paragraph and replace with the following:

When RAS is used, the JMF mix temperature shall be established at 275°F or higher.

Page 6-22, Article 610-4, WEATHER, TEMPERATURE AND SEASONAL LIMITATIONS FOR PRODUCING AND PLACING ASPHALT MIXTURES, lines 15-17, replace the second sentence of the first paragraph with the following:

Do not place asphalt material when the air or surface temperatures, measured at the location of the paving operation away from artificial heat, do not meet Table 610-5.

Page 6-23, Article 610-4, WEATHER, TEMPERATURE AND SEASONAL LIMITATIONS FOR PRODUCING AND PLACING ASPHALT MIXTURES, replace Table 610-5 with the following:

| Asphalt Concrete Mix Type | Minimum Surface and Air Temperature |
|----------------------------------|--------------------------------------------|
| B25.0B, C | 35°F |
| I19.0B, C, D | 35°F |
| SF9.5A, S9.5B | 40°F ^A |
| S9.5C, S12.5C | 45°F ^A |
| S9.5D, S12.5D | 50°F |

- A. For the final layer of surface mixes containing recycled asphalt shingles (RAS), the minimum surface and air temperature shall be 50°F.

Page 6-23, Subarticle 610-5(A), General, lines 33-34, replace the last sentence of the third paragraph with the following:

Produce the mixture at the asphalt plant within ± 25 °F of the JMF mix temperature. The temperature of the mixture, when discharged from the mixer, shall not exceed 350°F.

Page 6-26, Article 610-7, HAULING OF ASPHALT MIXTURE, lines 22-23, in the fourth sentence of the first paragraph replace “so as to overlap the top of the truck bed and” with “to”. Line 28, in the last paragraph, replace “+15 °F to -25 °F of the specified JMF temperature.” with “ ± 25 °F of the specified JMF mix temperature.”

Page 6-26, Article 610-8, SPREADING AND FINISHING, line 34, add the following new paragraph:

As referenced in Section 9.6.3 of the *HMA/QMS Manual*, use the automatic screed controls on the paver to control the longitudinal profile. Where approved by the Engineer, the Contractor has the option to use either a fixed or mobile string line.

Page 6-29, Article 610-13, FINAL SURFACE TESTING AND ACCEPTANCE, line 39, add the following after the first sentence in the first paragraph:

Smoothness acceptance testing using the inertial profiler is not required on ramps, loops and turn lanes.

Page 6-30, Subarticle 610-13(A), Option 1 – Inertial Profiler, lines 15-16, replace the fourth sentence of the fourth paragraph with the following:

The interval at which relative profile elevations are reported shall be 2”.

Page 6-30, Subarticle 610-13(A), Option 1 – Inertial Profiler, lines 25-28, replace the ninth paragraph with the following:

Operate the profiler at any speed as per the manufacturer’s recommendations to collect valid data.

Page 6-30, Subarticle 610-13(A), Option 1 – Inertial Profiler, lines 30-31, delete the third sentence of the tenth paragraph.

Page 6-31, Subarticle 610-13(A), Option 1 – Inertial Profiler, lines 11-13, replace the first sentence of the third paragraph with the following:

After testing, transfer the profile data from the profiler portable computer’s hard drive to a write once storage media (Flash drive, USB, DVD-R or CD-R) or electronic media approved by the Engineer.

Page 6-31, Subarticle 610-13(A), Option 1 – Inertial Profiler, lines 17-18, replace the first sentence of the fourth paragraph with the following:

Submit a report with the documentation and electronic data of the evaluation for each section to the Engineer within 10 days after completion of the smoothness testing. The report shall be in the tabular format for each 0.10 segment or a portion thereof with a summary of the MRI values and the localized roughness areas including corresponding project station numbers or acceptable reference points. Calculate the pay adjustments for all segments in accordance with the formulas in Sections (1) and (2) shown below. The Engineer shall review and approval all pay adjustments unless corrective action is required.

Page 6-31, Subarticle 610-13(A)(1), Acceptance for New Construction, lines 36-37, replace the third paragraph with the following:

The price adjustment will apply to each 0.10-mile section or prorated for a portion thereof, based on the Mean Roughness Index (MRI), the average IRI values from both wheel paths.

Page 6-32, Subarticle 610-13(A)(2), Localized Roughness, lines 12-16, replace the first paragraph with the following:

Areas of localized roughness shall be identified through the “Smoothness Assurance Module (SAM)” provided in the ProVAL software. Use the SAM report to optimize repair strategies by analyzing the measurements from profiles collected using inertial profilers. The ride quality threshold for localized roughness shall be 165 in/mile for any sections that are 15 ft. to 100 ft. in length at the continuous short interval of 25 ft. Submit a continuous roughness report to identify each section with project station numbers or reference points outside the threshold and identify all localized roughness, with the signature of the Operator included with the submitted IRI trace and electronic files.

Page 6-32, Subarticle 610-13(A)(2), Localized Roughness, line 21, add the following new paragraph:

If the Engineer does not require corrective action, the pay adjustment for each area of localized roughness shall be based on the following formula:

$$PA = (165 - LR\#) 5$$

Where:

- PA = Pay Adjustment (dollars)
- LR# = The Localized Roughness number determined from SAM report for the ride quality threshold

Page 6-41, Subarticle 650-3(B), Mix Design Criteria, replace Table 650-1 with the following:

| TABLE 650-1 OGAFC GRADATION CRITERIA | | | |
|-------------------------------------------------|------------------|---------------------------|---------------------------|
| <i>Sieve Size (mm)</i> | <i>Type FC-1</i> | <i>Type FC-1 Modified</i> | <i>Type FC-2 Modified</i> |
| 19.0 | - | - | 100 |
| 12.5 | 100 | 100 | 80 - 100 |
| 9.50 | 75 - 100 | 75 - 100 | 55 - 80 |
| 4.75 | 25 - 45 | 25 - 45 | 15 - 30 |
| 2.36 | 5 - 15 | 5 - 15 | 5 - 15 |
| 0.075 | 1.0 - 3.0 | 1.0 - 3.0 | 2.0 - 4.0 |

ASPHALT BINDER CONTENT OF ASPHALT PLANT MIXES:

(11-21-00) (Rev. 7-17-12)

609

SP6 R15

The approximate asphalt binder content of the asphalt concrete plant mixtures used on this project will be as follows:

| | | |
|--------------------------------------|---------------|------|
| Asphalt Concrete Base Course | Type B 25.0__ | 4.4% |
| Asphalt Concrete Intermediate Course | Type I 19.0__ | 4.8% |
| Asphalt Concrete Surface Course | Type S 4.75A | 6.8% |
| Asphalt Concrete Surface Course | Type SA-1 | 6.8% |
| Asphalt Concrete Surface Course | Type SF 9.5A | 6.7% |
| Asphalt Concrete Surface Course | Type S 9.5__ | 6.0% |
| Asphalt Concrete Surface Course | Type S 12.5__ | 5.6% |

The actual asphalt binder content will be established during construction by the Engineer within the limits established in the *2012 Standard Specifications*.

ASPHALT PLANT MIXTURES:

(7-1-95)

609

SP6 R20

Place asphalt concrete base course material in trench sections with asphalt pavement spreaders made for the purpose or with other equipment approved by the Engineer.

PRICE ADJUSTMENT - ASPHALT BINDER FOR PLANT MIX:

(11-21-00)

620

SP6 R25

Price adjustments for asphalt binder for plant mix will be made in accordance with Section 620 of the *2012 Standard Specifications*.

The base price index for asphalt binder for plant mix is **\$ 361.07** per ton.

This base price index represents an average of F.O.B. selling prices of asphalt binder at supplier's terminals on **March 1, 2017**.

SHOULDER WEDGE:

(9-20-11) (Rev. 8-21-12)

610

SP6 R03R

Revise the *2012 Standard Specifications* as follows:

Page 6-26, Article 610-8, add the following after line 43:

Attach a device, mounted on screed of paving equipment, capable of constructing a shoulder wedge with an angle of 30 degrees plus or minus 4 degrees along the outside edge of the roadway, measured from the horizontal plane in place after final compaction on the final surface course. Use an approved mechanical device which will form the asphalt mixture to produce a wedge with uniform texture, shape and density while automatically adjusting to varying heights.

Payment for use of this device will be incidental to the other pay items in the contract.

VARIABLE DEPTH MILLING:

The Contractor shall perform Variable Depth Milling as shown in the chart and detail in the plans, in accordance with the applicable requirements of Section 607 of the *Standard Specifications* and as directed by the Engineer.

Variable Depth Milling will be measured and paid for as the actual number of square yards milled in accordance with this special provision and accepted by the Engineer.

Payment will be made under:

Pay Item

Variable Depth Milling

Pay Unit

Square Yard

FINAL SURFACE TESTING NOT REQUIRED:

(5-18-04) (Rev. 2-16-16)

610

SP6 R45

Final surface testing is not required on this project in accordance with Section 610-13, *Final Surface Testing and Acceptance*.

EXTRA LENGTH GUARDRAIL POSTS:

(11-17-09)

SPI 8-21A

Description

The Contractor shall use extra length guardrail posts at the locations indicated in the plans and as directed by the Engineer.

Materials

| Item | Section |
|---------------------------|----------------|
| Guardrail Steel Post (8') | 1046-3 |

Construction Methods

Extra length guardrail posts shall be installed in accordance with Section 862 of the *Standard Specifications* and the *Roadway Standard Drawings*.

Measurement and Payment

Extra Length Guardrail Post will be measured and paid for in units of each that have been installed and accepted.

Payment will be made under:

| Pay Item | Pay Unit |
|----------------------------------------|-----------------|
| Extra Length Guardrail Post (8' Steel) | Each |

EMERGENCY VEHICLE ACCESS:

At locations shown in the plans, construct emergency vehicle accesses in accordance with the detail in the plans and Section 852 of the *Standard Specifications*.

Each emergency vehicle access section completed and accepted will be paid for at the contract unit price per each for *Emergency Vehicle Access*. Such price and payment will be full compensation for all materials, labor, equipment, tools, and any other incidentals necessary to complete the work satisfactorily.

The concrete island outside the pay limits of the emergency vehicle access limits will be measured and paid for in accordance with Section 852 of the *Standard Specifications*.

Payment will be made under:

| Pay Item | Pay Unit |
|--------------------------|-----------------|
| Emergency Vehicle Access | Each |

DETECTABLE WARNINGS FOR PROPOSED CURB RAMPS:

(6-15-10) (Rev. 8-16-11)

848

SP8 R126

Description

Construct detectable warnings consisting of integrated raised truncated domes on proposed concrete curb ramps in accordance with the *2012 Standard Specifications*, plan details, the requirements of the *28 CFR Part 36 ADA Standards for Accessible Design* and this provision.

Materials

Detectable warning for proposed curb ramps shall consist of integrated raised truncated domes. The description, size and spacing shall conform to Section 848 of the *2012 Standard Specifications*.

Use material for detectable warning systems as shown herein. Material and coating specifications must be stated in the Manufacturers Type 3 Certification and all Detectable Warning systems must be on the NCDOT Approved Products List.

Install detectable warnings created from one of the following materials: precast concrete blocks or bricks, clay paving brick, gray or ductile iron castings, mild steel, stainless steel, and engineered plastics, rubber or composite tile. Only one material type for detectable warning will be permitted per project, unless otherwise approved by the Engineer.

- (A) Detectable Warnings shall consist of a base with integrated raised truncated domes, and when constructed of precast concrete they shall conform to the material requirements of Article 848-2 of the *2012 Standard Specifications*.
- (B) Detectable Warnings shall consist of a base with integrated raised truncated domes, and may be comprised of other materials including, but not limited, to clay paving brick, gray iron or ductile iron castings, mild steel, stainless steel, and engineered plastics, rubber or composite tile, which are cast into the concrete of the curb ramps. The material shall have an integral color throughout the thickness of the material. The detectable warning shall include fasteners or anchors for attachment in the concrete and shall be furnished as a system from the manufacturer.

Prior to installation, the Contractor shall submit to the Engineer assembling instructions from the manufacturer for each type of system used in accordance with Article 105-2 of the *2012 Standard Specifications*. The system shall be furnished as a kit containing all consumable materials and consumable tools, required for the application. They shall be capable of being affixed to or anchored in the concrete curb ramp, including green concrete (concrete that has set but not appreciably hardened). The system shall be solvent free and contain no volatile organic compounds (VOC). The static coefficient of friction shall be 0.8 or greater when measured on top of the truncated domes and when measured between the domes in accordance with ASTM C1028 (dry and wet). The system shall be resistant to deterioration due to exposure to sunlight, water, salt or adverse weather conditions and impervious to degradation by motor fuels, lubricants and antifreeze.

- (C) When steel or gray iron or ductile iron casting products are provided, only products that meet the requirements of Subarticle 106-1(B) of the *2012 Standard Specifications* may be used. Submit to the Engineer a Type 6 Certification, catalog cuts and installation procedures at least 30 days prior to installation for all.

Construction Methods

- (A) Prior to placing detectable warnings in proposed concrete curb ramps, adjust the existing subgrade to the proper grade and in accordance with Article 848-3 of the *2012 Standard Specifications*.
- (B) Install all detectable warning in proposed concrete curb ramps in accordance with the manufacturer's recommendations.

Measurement and Payment

Detectable Warnings installed for construction of proposed curb ramps will not be paid for separately. Such payment will be included in the price bid for *Concrete Curb Ramps*.

MATERIALS:

(2-21-12) (Rev. 11-22-16) 1000, 1002, 1005, 1016, 1018, 1024, 1050, 1074, 1078, 1080, 1081, 1086, 1084, 1087, 1092 SP10 R01

Revise the *2012 Standard Specifications* as follows:

Page 10-1, Article 1000-1, DESCRIPTION, lines 9-10, replace the last sentence of the first paragraph with the following:

Type IL, IP, IS or IT blended cement may be used instead of Portland cement.

Page 10-1, Article 1000-1, DESCRIPTION, line 14, add the following:

If any change is made to the mix design, submit a new mix design (with the exception of an approved pozzolan source change).

If any major change is made to the mix design, also submit new test results showing the mix design conforms to the criteria. Define a major change to the mix design as:

- (1) A source change in coarse aggregate, fine aggregate or cement.
- (2) A pozzolan class or type change (e.g. Class F fly ash to Class C fly ash).
- (3) A quantitative change in coarse aggregate (applies to an increase or decrease greater than 5%), fine aggregate (applies to an increase or decrease greater than 5%), water (applies to an increase only), cement (applies to a decrease only), or pozzolan (applies to an increase or decrease greater than 5%).

Use materials which do not produce a mottled appearance through rusting or other staining of the finished concrete surface.

Page 10-1, Article 1000-2, MATERIALS, line 16; Page 10-8, Subarticle 1000-7(A), Materials, line 8; and Page 10-18, Article 1002-2, MATERIALS, line 9, add the following to the table of item references:

| Item | Section |
|------------------------|----------------|
| Type IL Blended Cement | 1024-1 |

Page 10-1, Subarticle 1000-3(A), Composition and Design, lines 25-27, replace the second paragraph with the following:

Fly ash may be substituted for cement in the mix design up to 30% at a rate of 1.0 lb of fly ash to each pound of cement replaced.

Page 10-2, Subarticle 1000-3(A), Composition and Design, lines 12-21, delete the third paragraph through the sixth paragraph beginning with “If any change is made to the mix design, submit...” through “...(applies to a decrease only).”

Page 10-5, Table 1000-1, REQUIREMENTS FOR CONCRETE, replace with the following:

| TABLE 1000-1 REQUIREMENTS FOR CONCRETE | | | | | | | | | | | |
|-------------------------------------------|--------------------------------------------------|----------------------------|-------------------|----------------------------|-------------------|---------------------------------------|--------------------|----------------|-----------|--------------|-----------|
| Class of Concrete | Min. Comp. Strength at 28 days | Maximum Water-Cement Ratio | | | | Consistency Max. Slump | | Cement Content | | | |
| | | Air-Entrained Concrete | | Non Air-Entrained Concrete | | Vibrated | Non-Vibrated | Vibrated | | Non-Vibrated | |
| | | Rounded Aggregate | Angular Aggregate | Rounded Aggregate | Angular Aggregate | | | Min. | Max. | Min. | Max. |
| Units | psi | | | | | inch | inch | lb/cy | lb/cy | lb/cy | lb/cy |
| AA | 4,500 | 0.381 | 0.426 | - | - | 3.5 | - | 639 | 715 | - | - |
| AA Slip Form | 4,500 | 0.381 | 0.426 | - | - | 1.5 | - | 639 | 715 | - | - |
| Drilled Pier | 4,500 | - | - | 0.450 | 0.450 | - | 5-7 dry 7-9 wet | - | - | 640 | 800 |
| A | 3,000 | 0.488 | 0.532 | 0.550 | 0.594 | 3.5 | 4 | 564 | - | 602 | - |
| B | 2,500 | 0.488 | 0.567 | 0.559 | 0.630 | 1.5 machine-placed 2.5 hand-placed | 4 | 508 | - | 545 | - |
| Sand Light-weight | 4,500 | - | 0.420 | - | - | 4 | - | 715 | - | - | - |
| Latex Modified | 3,000 7 day | 0.400 | 0.400 | - | - | 6 | - | 658 | - | - | - |
| Flowable Fill excavatable | 150 max. at 56 days | as needed | as needed | as needed | as needed | - | Flowable | - | - | 40 | 100 |
| Flowable Fill non-excavatable | 125 | as needed | as needed | as needed | as needed | - | Flowable | - | - | 100 | as needed |
| Pavement | 4,500 design, field 650 flexural, design only | 0.559 | 0.559 | - | - | 1.5 slip form 3.0 hand place | - | 526 | - | - | - |
| Precast | See Table 1077-1 | as needed | as needed | - | - | 6 | as needed | as needed | as needed | as needed | as needed |
| Prestress | per contract | See Table 1078-1 | See Table 1078-1 | - | - | 8 | - | 564 | as needed | - | - |

Page 10-6, Subarticle 1000-4(I), Use of Fly Ash, lines 36-2, replace the first paragraph with the following:

Fly ash may be substituted for cement in the mix design up to 30% at a rate of 1.0 lb of fly ash to each pound of cement replaced. Use Table 1000-1 to determine the maximum allowable water-cementitious material (cement + fly ash) ratio for the classes of concrete listed.

Page 10-7, Table 1000-3, MAXIMUM WATER-CEMENTITIOUS MATERIAL RATIO, delete the table.

Page 10-7, Article 1000-5, HIGH EARLY STRENGTH PORTLAND CEMENT CONCRETE, lines 30-31, delete the second sentence of the third paragraph.

Page 10-19, Article 1002-3, SHOTCRETE FOR TEMPORARY SUPPORT OF EXCAVATIONS, line 30, add the following at the end of Section 1002:

(H) Handling and Storing Test Panels

Notify the Area Materials Engineer when preconstruction or production test panels are made within 24 hours of shooting the panels. Field cure and protect test panels from damage in accordance with ASTM C1140 until the Department transports panels to the Materials and Tests Regional Laboratory for coring.

Page 10-23, Table 1005-1, AGGREGATE GRADATION-COARSE AGGREGATE, replace with the following:

| TABLE 1005-1 AGGREGATE GRADATION - COARSE AGGREGATE | | | | | | | | | | | | | |
|--------------------------------------------------------|---------------------------------------|--------|--------|--------|--------|--------|--------|-------|-------|------|-------|-------------------|------------------------------------------------------------------------|
| Std. Size # | Percentage of Total by Weight Passing | | | | | | | | | | | Remarks | |
| | 2" | 1 1/2" | 1" | 3/4" | 1/2" | 3/8" | #4 | #8 | #10 | #16 | #40 | | #200 |
| 4 | 100 | 90-100 | 20-55 | 0-15 | - | 0-5 | - | - | - | - | - | A | Asphalt Plant Mix |
| 467M | 100 | 95-100 | - | 35-70 | - | 0-30 | 0-5 | - | - | - | - | A | Asphalt Plant Mix |
| 5 | - | 100 | 90-100 | 20-55 | 0-10 | 0-5 | - | - | - | - | - | A | AST, Sediment Control Stone |
| 57 | - | 100 | 95-100 | - | 25-60 | - | 0-10 | 0-5 | - | - | - | A | AST, Structural Concrete, Shoulder Drain Stone, Sediment Control Stone |
| 57M | - | 100 | 95-100 | - | 25-45 | - | 0-10 | 0-5 | - | - | - | A | AST, Concrete Pavement |
| 6M | - | - | 100 | 90-100 | 20-55 | 0-20 | 0-8 | - | - | - | - | A | AST |
| 67 | - | - | 100 | 90-100 | - | 20-55 | 0-10 | 0-5 | - | - | - | A | Asphalt Plant Mix, AST, Structural Concrete |
| 78M | - | - | - | 100 | 98-100 | 75-100 | 20-45 | 0-15 | - | - | - | A | Asphalt Plant Mix, AST, Structural Concrete, Weep Hole Drains |
| 14M | - | - | - | - | 100 | 98-100 | 35-70 | 5-20 | - | 0-8 | - | A | Asphalt Plant Mix, AST, Structural Concrete, Weep Hole Drains |
| 9M | - | - | - | - | 100 | 98-100 | 85-100 | 10-40 | - | 0-10 | - | A | AST |
| ABC | - | 100 | 75-97 | - | 55-80 | - | 35-55 | - | 25-45 | - | 14-30 | 4-12 ^B | Aggregate Base Course, Aggregate Stabilization |
| ABC(M) | - | 100 | 75-100 | - | 45-79 | - | 20-40 | - | 0-25 | - | - | 0-12 ^B | Maintenance Stabilization |
| Light-weight ^C | - | - | - | - | 100 | 80-100 | 5-40 | 0-20 | - | 0-10 | - | 0-2.5 | AST |

- A. See Subarticle 1005-4(A).
- B. See Subarticle 1005-4(B).
- C. For Lightweight Aggregate used in Structural Concrete, see Subarticle 1014-2(E)(6).

Page 10-39, Article 1016-3, CLASSIFICATIONS , lines 27-32, replace with the following:

Select material is clean, unweathered durable, blasted rock material obtained from an approved source. While no specific gradation is required, the below criteria will be used to evaluate the materials for visual acceptance by the Engineer:

- (A) At least 50% of the rock has a diameter of from 1.5 ft to 3 ft,
- (B) 30% of the rock ranges in size from 2” to 1.5 ft in diameter, and
- (C) Not more than 20% of the rock is less than 2” in diameter. No rippable rock will be permitted.

Page 10-40, Tables 1018-1 and 1018-2, PIEDMONT, WESTERN AND COASTAL AREA CRITERIA FOR ACCEPTANCE OF BORROW MATERIAL, under second column in both tables, replace second row with the following:

Acceptable, but not to be used in the top 3 ft of embankment or backfill

Page 10-46, Article 1024-1, PORTLAND CEMENT, line 33, add the following as the ninth paragraph:

Use Type IL blended cement that meets AASHTO M 240, except that the limestone content is limited to between 5 and 12% by weight and the constituents shall be interground. Class F fly ash can replace a portion of Type IL blended cement and shall be replaced as outlined in Subarticle 1000-4(I) for Portland cement. For mixes that contain cement with alkali content between 0.6% and 1.0% and for mixes that contain a reactive aggregate documented by the Department, use a pozzolan in the amount shown in Table 1024-1.

Page 10-46, Table 1024-1, POZZOLANS FOR USE IN PORTLAND CEMENT CONCRETE, replace with the following:

| TABLE 1024-1 POZZOLANS FOR USE IN PORTLAND CEMENT CONCRETE | |
|-----------------------------------------------------------------------|------------------------------------------------------------------------------------------------------|
| Pozzolan | Rate |
| Class F Fly Ash | 20% - 30% by weight of required cement content with 1.0 lb Class F fly ash per lb of cement replaced |
| Ground Granulated Blast Furnace Slag | 35%-50% by weight of required cement content with 1.0 lb slag per lb of cement replaced |
| Microsilica | 4%-8% by weight of required cement content with 1.0 lb microsilica per lb of cement replaced |

Page 10-47, Subarticle 1024-3(B), Approved Sources, lines 16-18, replace the second sentence of the second paragraph with the following:

Tests shall be performed by AASHTO’s designated National Transportation Product Evaluation Program (NTPEP) laboratory for concrete admixture testing.

Page 10-65, Article 1050-1, GENERAL, line 41, replace the first sentence with the following:

All fencing material and accessories shall meet Section 106.

Page 10-115, Subarticle 1074-7(B), Gray Iron Castings, lines 10-11, replace the first two sentences with the following:

Supply gray iron castings meeting all facets of AASHTO M 306 excluding proof load. Proof load testing will only be required for new casting designs during the design process, and conformance to M306 loading (40,000 lb.) will be required only when noted on the design documents.

Page 10-126, Table 1078-1, REQUIREMENTS FOR CONCRETE, replace with the following:

| Property | 28 Day Design Compressive Strength 6,000 psi or less | 28 Day Design Compressive Strength greater than 6,000 psi |
|-------------------------------------------|------------------------------------------------------------|-----------------------------------------------------------------------|
| Maximum Water/Cementitious Material Ratio | 0.45 | 0.40 |
| Maximum Slump without HRWR | 3.5" | 3.5" |
| Maximum Slump with HRWR | 8" | 8" |
| Air Content (upon discharge into forms) | 5 + 2% | 5 + 2% |

Page 10-151, Article 1080-4, INSPECTION AND SAMPLING, lines 18-22, replace (B), (C) and (D) with the following:

- (B) At least 3 panels prepared as specified in 5.5.10 of AASHTO M 300, Bullet Hole Immersion Test.
- (C) At least 3 panels of 4"x6"x1/4" for the Elcometer Adhesion Pull Off Test, ASTM D4541.
- (D) A certified test report from an approved independent testing laboratory for the Salt Fog Resistance Test, Cyclic Weathering Resistance Test, and Bullet Hole Immersion Test as specified in AASHTO M 300.
- (E) A certified test report from an approved independent testing laboratory that the product has been tested for slip coefficient and meets AASHTO M253, Class B.

Page 10-161, Subarticle 1081-1(A), Classifications, lines 29-33, delete first 3 sentences of the description for Type 2 and replace with the following:

Type 2 - A low-modulus, general-purpose adhesive used in epoxy mortar repairs. It may be used to patch spalled, cracked or broken concrete where vibration, shock or expansion and contraction are expected.

Page 10-162, Subarticle 1081-1(A), Classifications, lines 4-7, delete the second and third sentences of the description for Type 3A. **Lines 16-22,** delete Types 6A, 6B and 6C.

Page 10-162, Subarticle 1081-1(B), Requirements, lines 26-30, replace the second paragraph with the following:

For epoxy resin systems used for embedding dowel bars, threaded rods, rebar, anchor bolts and other fixtures in hardened concrete, the manufacturer shall submit test results showing that the bonding system will obtain 125% of the specified required yield strength of the fixture. Furnish certification that, for the particular bolt grade, diameter and embedment depth required, the anchor system will not fail by adhesive failure and that there is no movement of the anchor bolt. For certification and anchorage, use 3,000 psi as the minimum Portland cement concrete compressive strength used in this test. Use adhesives that meet Section 1081.

List the properties of the adhesive on the container and include density, minimum and maximum temperature application, setting time, shelf life, pot life, shear strength and compressive strength.

Page 10-163, Table 1081-1, PROPERTIES OF MIXED EPOXY RESIN SYSTEMS, replace with the following:

| TABLE 1081-1 PROPERTIES OF MIXED EPOXY RESIN SYSTEMS | | | | | | | |
|-----------------------------------------------------------------|---------------|---------------|---------------|----------------|----------------|----------------|---------------|
| Property | Type 1 | Type 2 | Type 3 | Type 3A | Type 4A | Type 4B | Type 5 |
| Viscosity-Poises at 77°F ± 2°F | Gel | 10-30 | 25-75 | Gel | 40-150 | 40-150 | 1-6 |
| Spindle No. | - | 3 | 4 | -- | 4 | 4 | 2 |
| Speed (RPM) | - | 20 | 20 | -- | 10 | 10 | 50 |
| Pot Life (Minutes) | 20-50 | 30-60 | 20-50 | 5-50 | 40-80 | 40-80 | 20-60 |
| Minimum Tensile Strength at 7 days (psi) | 1,500 | 2,000 | 4,000 | 4,000 | 1,500 | 1,500 | 4,000 |
| Tensile Elongation at 7 days (%) | 30 min. | 30 min. | 2-5 | 2-5 | 5-15 | 5-15 | 2-5 |
| Min. Compressive Strength of 2" mortar cubes at 24 hours | 3,000 (Neat) | 4,000- | 6,000- | 6,000 (Neat) | 3,000 | 3,000 | 6,000 |
| Min. Compressive Strength of 2" mortar cubes at 7 days | 5,000 (Neat) | - | - | - | - | 5,000 | - |
| Maximum Water Absorption (%) | 1.5 | 1.0 | 1.0 | 1.5 | 1.0 | 1.0 | 1.0 |
| Min. Bond Strength Slant Shear Test at 14 days (psi) | 1,500 | 1,500 | 2,000 | 2,000 | 1,500 | 1,500 | 1,500 |

Page 10-164, Subarticle 1081-1(E), Prequalification, lines 31-33, replace the second sentence of the first paragraph with the following:

Manufacturers choosing to supply material for Department jobs must submit an application through the Value Management Unit with the following information for each type and brand name:

Page 10-164, Subarticle 1081-1(E)(3), line 37, replace with the following:

(3) Type of the material in accordance with Articles 1081-1 and 1081-4,

Page 10-165, Subarticle 1081-1(E)(6), line 1, in the first sentence of the first paragraph replace “AASHTO M 237” with “the specifications”.

Page 10-165, Subarticle 1081-1(E), Prequalification, line 9-10, delete the second sentence of the last paragraph.

Page 10-165, Subarticle 1081-1(F), Acceptance, line 14, in the first sentence of the first paragraph replace “Type 1” with “Type 3”.

Page 10-169, Subarticle 1081-3(G), Anchor Bolt Adhesives, delete this subarticle.

Page 10-170, Article 1081-3, HOT BITUMEN, line 9, add the following at the end of Section 1081:

1081-4 EPOXY RESIN ADHESIVE FOR BONDING TRAFFIC MARKINGS

(A) General

This section covers epoxy resin adhesive for bonding traffic markers to pavement surfaces.

(B) Classification

The types of epoxies and their uses are as shown below:

Type I – Rapid Setting, High Viscosity, Epoxy Adhesive. This type of adhesive provides rapid adherence to traffic markers to the surface of pavement.

Type II – Standard Setting, High Viscosity, Epoxy Adhesive. This type of adhesive is recommended for adherence of traffic markers to pavement surfaces when rapid set is not required.

Type III – Rapid Setting, Low Viscosity, Water Resistant, Epoxy Adhesive. This type of rapid setting adhesive, due to its low viscosity, is appropriate only for use with embedded traffic markers.

Type IV – Standard Set Epoxy for Blade Deflecting-Type Plowable Markers.

(C) Requirements

Epoxies shall conform to the requirements set forth in AASHTO M 237.

(D) Prequalification

Refer to Subarticle 1081-1(E).

(E) Acceptance

Refer to Subarticle 1081-1(F).

Page 10-173, Article 1084-2, STEEL SHEET PILES, lines 37-38, replace first paragraph with the following:

Steel sheet piles detailed for permanent applications shall be hot rolled and meet ASTM A572 or ASTM A690 unless otherwise required by the plans. Steel sheet piles shall be coated as required by the plans. Galvanized sheet piles shall be coated in accordance with Section 1076. Metallized sheet piles shall be metallized in accordance to the Project Special Provision “Thermal Sprayed Coatings (Metallization)” with an 8 mil, 99.9% aluminum alloy coating and a 0.5 mil seal coating. Any portion of the metallized sheet piling encased in concrete shall receive a barrier coat. The barrier coat shall be an approved waterborne coating with a low-viscosity which readily absorbs into the pores of the aluminum thermal sprayed coating. The waterborne coating shall be applied at a spreading rate that results in a theoretical 1.5 mil dry film thickness. The manufacturer shall issue a letter of certification that the resin chemistry of the waterborne coating is compatible with the 99.9% aluminum thermal sprayed alloy and suitable for tidal water applications.

Page 10-174, Subarticle 1086-1(B)(1), Epoxy, lines 18-24, replace with the following:

The epoxy shall meet Article 1081-4.

The 2 types of epoxy adhesive which may be used are Type I, Rapid Setting, and Type II, Standard Setting. Use Type II when the pavement temperature is above 60°F or per the manufacturer’s recommendations whichever is more stringent. Use Type I when the pavement temperature is between 50°F and 60°F or per the manufacturer’s recommendations whichever is more stringent. Epoxy adhesive Type I, Cold Set, may be used to attach temporary pavement markers to the pavement surface when the pavement temperature is between 32°F and 50°F or per the manufacturer’s recommendations whichever is more stringent.

Page 10-175, Subarticle 1086-2(E), Epoxy Adhesives, line 27, replace “Section 1081” with “Article 1081-4”.

Page 10-177, Subarticle 1086-3(E), Epoxy Adhesives, line 22, replace “Section 1081” with “Article 1081-4”.

Page 10-179, Subarticle 1087-4(A), Composition, lines 39-41, replace the third paragraph with the following:

All intermixed and drop-on glass beads shall not contain more than 75 ppm arsenic or 200 ppm lead.

Page 10-180, Subarticle 1087-4(B), Physical Characteristics, line 8, replace the second paragraph with the following:

All intermixed and drop-on glass beads shall comply with NCGS § 136-30.2 and 23 USC § 109(r).

Page 10-181, Subarticle 1087-7(A), Intermixed and Drop-on Glass Beads, line 24, add the following after the first paragraph:

Use X-ray Fluorescence for the normal sampling procedure for intermixed and drop-on beads, without crushing, to check for any levels of arsenic and lead. If any arsenic or lead is detected, the sample shall be crushed and repeat the test using X-ray Fluorescence. If the X-ray Fluorescence test shows more than a LOD of 5 ppm, test the beads using United States Environmental Protection Agency Method 6010B, 6010C or 3052 for no more than 75 ppm arsenic or 200 ppm lead.

SHOULDER AND SLOPE BORROW:

(3-19-13)

1019

SP10 R10

Use soil in accordance with Section 1019 of the *2012 Standard Specifications*. Use soil consisting of loose, friable, sandy material with a PI greater than 6 and less than 25 and a pH ranging from 5.5 to 7.0.

Soil with a pH ranging from 4.0 to 5.5 will be accepted without further testing if additional limestone is provided in accordance with the application rates shown in Table 1019-1A. Soil type is identified during the soil analysis. Soils with a pH above 7.0 require acidic amendments to be added. Submit proposed acidic amendments to the Engineer for review and approval. Soils with a pH below 4.0 or that do not meet the PI requirements shall not be used.

| pH TEST RESULT | Sandy Soils Additional Rate (lbs. / Acre) | Silt Loam Soils Additional Rate (lbs. / Acre) | Clay Loam Soils Additional Rate (lbs. / Acre) |
|-----------------------|----------------------------------------------------------|--------------------------------------------------------------|--------------------------------------------------------------|
| 4.0 - 4.4 | 1,000 | 4,000 | 6,000 |
| 4.5 - 4.9 | 500 | 3,000 | 5,000 |
| 5.0 - 5.4 | NA | 2,000 | 4,000 |

Note: Limestone application rates shown in this table are in addition to the standard rate of 4000 lbs. / acre required for seeding and mulching.

No direct payment will be made for providing additional lime or acidic amendments for Ph adjustment.

GROUT PRODUCTION AND DELIVERY:

(3-17-15)

1003

Revise the *2012 Standard Specifications* as follows:

Replace Section 1003 with the following:

**SECTION 1003
GROUT PRODUCTION AND DELIVERY**

1003-1 DESCRIPTION

This section addresses cement grout to be used for structures, foundations, retaining walls, concrete barriers, embankments, pavements and other applications in accordance with the contract. Produce non-metallic grout composed of Portland cement and water and at the Contractor's option or as required, aggregate and pozzolans. Include chemical admixtures as required or needed. Provide sand cement or neat cement grout as required. Define "sand cement grout" as grout with only fine aggregate and "neat cement grout" as grout without aggregate.

The types of grout with their typical uses are as shown below:

Type 1 – A cement grout with only a 3-day strength requirement and a fluid consistency that is typically used for filling subsurface voids.

Type 2 – A nonshrink grout with strength, height change and flow conforming to ASTM C1107 that is typically used for foundations, ground anchors and soil nails.

Type 3 – A nonshrink grout with high early strength and freeze-thaw durability requirements that is typically used in pile blockouts, grout pockets, shear keys, dowel holes and recesses for concrete barriers and structures.

Type 4 – A neat cement grout with low strength, a fluid consistency and high fly ash content that is typically used for slab jacking.

Type 5 – A low slump, low mobility sand cement grout with minimal strength that is typically used for compaction grouting.

1003-2 MATERIALS

Refer to Division 10.

| Item | Section |
|--------------------------------------|----------------|
| Chemical Admixtures | 1024-3 |
| Fine Aggregate | 1014-1 |
| Fly Ash | 1024-5 |
| Ground Granulated Blast Furnace Slag | 1024-6 |
| Portland Cement | 1024-1 |
| Silica Fume | 1024-7 |
| Water | 1024-4 |

Do not use grout that contains soluble chlorides or more than 1% soluble sulfate. At the Contractor's option, use an approved packaged grout instead of the materials above except for water. Use packaged grouts that are on the NCDOT Approved Products List.

Use admixtures for grout that are on the NCDOT Approved Products List or other admixtures in accordance with Subarticle 1024-3(E) except do not use concrete additives or unclassified or other admixtures in Type 4 or 5 grout. Use Class F fly ash for Type 4 grout and Type II Portland cement for Type 5 grout.

Use well graded rounded aggregate with a gradation, liquid limit (LL) and plasticity index (PI) that meet Table 1003-1 for Type 5 grout. Fly ash may be substituted for a portion of the fines in the aggregate. Do not use any other pozzolans in Type 5 grout.

| Gradation | | Maximum Liquid Limit | Maximum Plasticity Index |
|----------------------------------------------|---------------------------------------------|---------------------------------|-------------------------------------|
| Sieve Designation per AASHTO M 92 | Percentage Passing (% by weight) | | |
| 3/8" | 100 | N/A | N/A |
| No. 4 | 70 – 95 | | |
| No. 8 | 50 – 90 | | |
| No. 16 | 30 – 80 | | |
| No. 30 | 25 – 70 | | |
| No. 50 | 20 – 50 | | |
| No. 100 | 15 – 40 | | |
| No. 200 | 10 – 30 | 25 | 10 |

1003-3 COMPOSITION AND DESIGN

When using an approved packaged grout, a grout mix design submittal is not required. Otherwise, submit proposed grout mix designs for each grout mix to be used in the work. Mixes for all grout shall be designed by a Certified Concrete Mix Design Technician or an Engineer licensed by the State of North Carolina. Mix proportions shall be determined by a testing laboratory approved by the Department. Base grout mix designs on laboratory trial batches that meet Table 1003-2 and this section. With permission, the Contractor may

use a quantity of chemical admixture within the range shown on the current list of approved admixtures maintained by the Materials and Tests Unit.

Submit grout mix designs in terms of saturated surface dry weights on Materials and Tests Form 312U at least 35 days before proposed use. Adjust batch proportions to compensate for surface moisture contained in the aggregates at the time of batching. Changes in the saturated surface dry mix proportions will not be permitted unless revised grout mix designs have been submitted to the Engineer and approved.

Accompany Materials and Tests Form 312U with a listing of laboratory test results of compressive strength, density and flow or slump and if applicable, aggregate gradation, durability and height change. List the compressive strength of at least three 2" cubes at the age of 3 and 28 days.

The Engineer will review the grout mix design for compliance with the contract and notify the Contractor as to its acceptability. Do not use a grout mix until written notice has been received. Acceptance of the grout mix design or use of approved packaged grouts does not relieve the Contractor of his responsibility to furnish a product that meets the contract. Upon written request from the Contractor, a grout mix design accepted and used satisfactorily on any Department project may be accepted for use on other projects.

Perform laboratory tests in accordance with the following test procedures:

| Property | Test Method |
|----------------------------------|----------------------------------------------------------------------------------------------------------|
| Aggregate Gradation ^A | AASHTO T 27 |
| Compressive Strength | AASHTO T 106 |
| Density (Unit Weight) | AASHTO T 121, AASHTO T 133 ^B , ANSI/API RPC 13B-1 ^B (Section 4, Mud Balance) |
| Durability | AASHTO T 161 ^D |
| Flow | ASTM C939 (Flow Cone) |
| Height Change | ASTM C1090 ^E |
| Slump | AASHTO T 119 |

- A.** Applicable to grout with aggregate.
- B.** Applicable to Neat Cement Grout.
- C.** American National Standards Institute/American Petroleum Institute Recommended Practice.
- D.** Procedure A (Rapid Freezing and Thawing in Water) required.
- E.** Moist room storage required.

1003-4 GROUT REQUIREMENTS

Provide grout types in accordance with the contract. Use grouts with properties that meet Table 1003-2. The compressive strength of the grout will be considered the average compressive strength test results of three 2" cubes at each age. Make cubes that meet AASHTO T 106 from the grout delivered for the work or mixed on-site. Make cubes at

such frequencies as the Engineer may determine and cure them in accordance with AASHTO T 106.

| Type of Grout | Minimum Compressive Strength at | | Height Change at 28 days | Flow ^A /Slump ^B | Minimum Durability Factor |
|----------------|---------------------------------|-----------|--------------------------|-----------------------------------------------------------|---------------------------|
| | 3 days | 28 days | | | |
| 1 | 3,000 psi | – | – | 10 – 30 sec | – |
| 2 | Table 1 ^C | | | Fluid Consistency ^C | – |
| 3 | 5,000 psi | – | 0 – 0.2% | Per Accepted Grout Mix Design/ Approved Packaged Grout | 80 |
| 4 ^D | 600 psi | 1,500 psi | – | 10 – 26 sec | – |
| 5 | – | 500 psi | – | 1 – 3" | – |

A. Applicable to Type 1 through 4 grouts.

B. Applicable to Type 5 grout.

C. ASTM C1107.

D. Use Type 4 grout with proportions by volume of 1 part cement and 3 parts fly ash.

1003-5 TEMPERATURE REQUIREMENTS

When using an approved packaged grout, follow the manufacturer's instructions for grout and air temperature at the time of placement. Otherwise, the grout temperature at the time of placement shall be not less than 50°F nor more than 90°F. Do not place grout when the air temperature measured at the location of the grouting operation in the shade away from artificial heat is below 40°F.

1003-6 ELAPSED TIME FOR PLACING GROUT

Agitate grout continuously before placement. Regulate the delivery so the maximum interval between the placing of batches at the work site does not exceed 20 minutes. Place grout before exceeding the times in Table 1003-3. Measure the elapsed time as the time between adding the mixing water to the grout mix and placing the grout.

| TABLE 1003-3 ELAPSED TIME FOR PLACING GROUT (with continuous agitation) | | |
|----------------------------------------------------------------------------------------|--------------------------------------------|-----------------------------------------|
| Air or Grout Temperature, Whichever is Higher | Maximum Elapsed Time | |
| | No Retarding Admixture Used | Retarding Admixture Used |
| 90°F or above | 30 minutes | 1 hr. 15 minutes |
| 80°F through 89°F | 45 minutes | 1 hr. 30 minutes |
| 79°F or below | 60 minutes | 1 hr. 45 minutes |

1003-7 MIXING AND DELIVERY

Use grout free of any lumps and undispersed cement. When using an approved packaged grout, mix grout in accordance with the manufacturer's instructions. Otherwise, comply with Articles 1000-8 through 1000-12 to the extent applicable for grout instead of concrete.

GEOSYNTHETICS:

(2-16-16)

1056

SP10 R25

Revise the *2012 Standard Specifications* as follows:

Replace Section 1056 with the following:

SECTION 1056 GEOSYNTHETICS

1056-1 DESCRIPTION

Provide geosynthetics for subsurface drainage, separation, stabilization, reinforcement, erosion control, filtration and other applications in accordance with the contract. Use geotextiles, geocomposite drains and geocells that are on the NCDOT Approved Products List. Prefabricated geocomposite drains include sheet, strip and vertical drains (PVDs), i.e., "wick drains" consisting of a geotextile attached to and/or encapsulating a plastic drainage core. Geocells are comprised of ultrasonically welded polymer strips that when expanded form a 3D honeycomb grid that is typically filled with material to support vegetation.

If necessary or required, hold geotextiles and sheet drains in place with new wire staples, i.e., "sod staples" that meet Subarticle 1060-8(D) or new anchor pins. Use steel anchor pins with a diameter of at least 3/16" and a length of at least 18" and with a point at one end and a head at the other end that will retain a steel washer with an outside diameter of at least 1.5".

1056-2 HANDLING AND STORING

Load, transport, unload and store geosynthetics so geosynthetics are kept clean and free of damage. Label, ship and store geosynthetics in accordance with Section 7 of AASHTO M 288. Geosynthetics with defects, flaws, deterioration or damage will be rejected. Do not unwrap geosynthetics until just before installation. Do not leave geosynthetics exposed for more than 7 days before covering except for geosynthetics for temporary wall faces and erosion control.

1056-3 CERTIFICATIONS

Provide Type 1, Type 2 or Type 4 material certifications in accordance with Article 106-3 for geosynthetics. Define “minimum average roll value” (MARV) in accordance with ASTM D4439. Provide certifications with MARV for geosynthetic properties as required. Test geosynthetics using laboratories accredited by the Geosynthetic Accreditation Institute (GAI) to perform the required test methods. Sample geosynthetics in accordance with ASTM D4354.

1056-4 GEOTEXTILES

When required, sew geotextiles together in accordance with Article X1.1.4 of AASHTO M 288. Provide sewn seams with seam strengths meeting the required strengths for the geotextile type and class specified.

Provide geotextile types and classes in accordance with the contract. Geotextiles will be identified by the product name printed directly on the geotextile. When geotextiles are not marked with a product name or marked with only a manufacturing plant identification code, geotextiles will be identified by product labels attached to the geotextile wrapping. When identification is based on labels instead of markings, unwrap geotextiles just before use in the presence of the Engineer to confirm that the product labels on both ends of the outside of the geotextile outer wrapping match the labels affixed to both ends of the inside of the geotextile roll core. Partial geotextile rolls without the product name printed on the geotextile or product labels affixed to the geotextile roll core may not be used.

Use woven or nonwoven geotextiles with properties that meet Table 1056-1. Define “machine direction” (MD) and “cross-machine direction” (CD) in accordance with ASTM D4439.

| Property | Requirement | | | | | Test Method |
|-------------------------------------|---------------------------------------------------------------------------------------|--------------------------------------------------------------------------------------|--------------------------|-----------------------------------|-------------------------------------------------------------------------|-------------|
| | Type 1 | Type 2 | Type 3 ^A | Type 4 | Type 5 ^B | |
| <i>Typical Application</i> | <i>Shoulder Drains</i> | <i>Under Rip Rap</i> | <i>Silt Fence Fabric</i> | <i>Soil Stabilization</i> | <i>Temporary Walls</i> | |
| Elongation (MD & CD) | ≥ 50% | ≥ 50% | ≤ 25% | < 50% | < 50% | ASTM D4632 |
| Grab Strength (MD & CD) | | | 100 lb ^C | | | ASTM D4632 |
| Tear Strength (MD & CD) | Table 1 ^D , Class 3 | Table 1 ^D , Class 1 | – | Table 1 ^D , Class 3 | – | ASTM D4533 |
| Puncture Strength | | | – | | | ASTM D6241 |
| Ultimate Tensile Strength (MD & CD) | – | – | – | – | 2,400 lb/ft ^C (unless required otherwise in the contract) | ASTM D4595 |
| Permittivity | Table 2 ^D , 15% to 50% in <i>Situ</i> Soil Passing 0.075 mm | Table 6 ^D , 15% to 50% in <i>Situ</i> Soil Passing 0.075mm | Table 7 ^D | Table 5 ^D | 0.20 sec ⁻¹ . ^C | ASTM D4491 |
| Apparent Opening Size | | | | | 0.60 mm ^E | ASTM D4751 |
| UV Stability (Retained Strength) | | | | | 70% ^C (after 500 hr of exposure) | ASTM D4355 |

- A. Minimum roll width of 36" required.
 B. Minimum roll width of 13 ft required.
 C. MARV per Article 1056-3.
 D. AASHTO M 288.
 E. Maximum average roll value.

1056-5 GEOCOMPOSITE DRAINS

Provide geocomposite drain types in accordance with the contract and with properties that meet Table 1056-2.

| Property | Requirement | | | Test Method |
|--------------------------------------------------------------------------------------|-----------------------------------------------------------|--------------------------------------------------------------|-----------------------------------------------------------------------|-------------|
| | Sheet Drain | Strip Drain | Wick Drain | |
| Width | ≥ 12" (unless required otherwise in the contract) | 12" ±1/4" | 4" ±1/4" | N/A |
| In-Plane Flow Rate ^A (with gradient of 1.0 and 24-hour seating period) | 6 gpm/ft @ applied normal compressive stress of 10 psi | 15 gpm/ft @ applied normal compressive stress of 7.26 psi | 1.5 gpm ^B @ applied normal compressive stress of 40 psi | ASTM D4716 |

- A. MARV per Article 1056-3.
- B. Per 4" drain width.

For sheet and strip drains, use accessories (e.g., pipe outlets, connectors, fittings, etc.) recommended by the Drain Manufacturer. Provide sheet and strip drains with Type 1 geotextiles heat bonded or glued to HDPE, polypropylene or high impact polystyrene drainage cores that meet Table 1056-3.

| TABLE 1056-3 DRAINAGE CORE REQUIREMENTS | | | |
|----------------------------------------------------|---------------------------|--------------------|---------------------|
| Property | Requirement (MARV) | | Test Method |
| | Sheet Drain | Strip Drain | |
| Thickness | 1/4" | 1" | ASTM D1777 or D5199 |
| Compressive Strength | 40 psi | 30 psi | ASTM D6364 |

For wick drains with a geotextile wrapped around a corrugated drainage core and seamed to itself, use drainage cores with an ultimate tensile strength of at least 225 lb per 4" width in accordance with ASTM D4595 and geotextiles with properties that meet Table 1056-4.

| TABLE 1056-4 WICK DRAIN GEOTEXTILE REQUIREMENTS | | | |
|------------------------------------------------------------|-------------------------------------------------------------------------|--|--------------------|
| Property | Requirement | | Test Method |
| Elongation | $\geq 50\%$ | | ASTM D4632 |
| Grab Strength | Table 1 ^A , Class 3 | | ASTM D4632 |
| Tear Strength | | | ASTM D4533 |
| Puncture Strength | | | ASTM D6241 |
| Permittivity | 0.7 sec ^{-1.B} | | ASTM D4491 |
| Apparent Opening Size (AOS) | Table 2 ^A , > 50% <i>in Situ</i> Soil Passing 0.075 mm | | ASTM D4751 |
| UV Stability (Retained Strength) | | | ASTM D4355 |

- A. AASHTO M 288.
- B. MARV per Article 1056-3.

For wick drains with a geotextile fused to both faces of a corrugated drainage core along the peaks of the corrugations, use wick drains with an ultimate tensile strength of at least 1,650 lb/ft in accordance with ASTM D4595 and geotextiles with a permittivity, AOS and UV stability that meet Table 1056-4.

1056-6 GEOCELLS

Geocells will be identified by product labels attached to the geocell wrapping. Unwrap geocells just before use in the presence of the Engineer. Previously opened geocell products will be rejected.

Manufacture geocells from virgin polyethylene resin with no more than 10% rework, also called "regrind", materials. Use geocells made from textured and perforated HDPE strips with an open area of 10% to 20% and properties that meet Table 1056-5.

| TABLE 1056-5 GEOCELL REQUIREMENTS | | |
|---------------------------------------------------------------------------------------------------------|----------------------------|-------------------------------------------------------------|
| Property | Minimum Requirement | Test Method |
| Cell Depth | 4" | N/A |
| Sheet Thickness | 50 mil -5%, +10% | ASTM D5199 |
| Density | 58.4 lb/cf | ASTM D1505 |
| Carbon Black Content | 1.5% | ASTM D1603 or D4218 |
| ESCR ^A | 5000 hr | ASTM D1693 |
| Coefficient of Direct Sliding (with material that meets AASHTO M 145 for soil classification A-2) | 0.85 | ASTM D5321 |
| Short-Term Seam (Peel) Strength (for 4" seam) | 320 lb | USACE ^C Technical Report GL-86-19, Appendix A |
| Long-Term Seam (Hang) Strength ^B (for 4" seam) | 160 lb | |

A. Environmental Stress Crack Resistance.

B. Minimum test period of 168 hr with a temperature change from 74°F to 130°F in 1-hour cycles.

C. US Army Corps of Engineers.

Provide geocell accessories (e.g., stakes, pins, clips, staples, rings, tendons, anchors, deadmen, etc.) recommended by the Geocell Manufacturer.

TRUCK MOUNTED CHANGEABLE MESSAGE SIGNS:

(8-21-12)

1101.02

SP11 R10

Revise the *2012 Roadway Standard Drawings* as follows:

Drawing No. 1101.02, Sheet 12, TEMPORARY LANE CLOSURES, replace General Note #11 with the following:

11- TRUCK MOUNTED CHANGEABLE MESSAGE SIGNS (TMCMS) USED ON SHADOW VEHICLES FOR "IN LANE" ACTIVITIES SHALL BE A MINIMUM OF 43" X 73". THE DISPLAY PANEL SHALL HAVE FULL MATRIX CAPABILITY WITH THE CAPABILITY TO PROVIDE 2 MESSAGE LINES WITH 7 CHARACTERS PER LINE WITH A MINIMUM CHARACTER HEIGHT OF 18". FOR ADDITIONAL MESSAGING, CONTACT THE WORK ZONE TRAFFIC CONTROL SECTION.

12- TMCMS USED FOR ADVANCED WARNING ON VEHICLES LOCATED ON THE SHOULDER MAY BE SMALLER THAN 43" X 73". THE DISPLAY PANEL SHALL HAVE THE CAPABILITY TO PROVIDE 2 MESSAGE LINES WITH 7 CHARACTERS PER LINE WITH A MINIMUM CHARACTER HEIGHT OF 18". FOR ADDITIONAL MESSAGING, CONTACT THE WORK ZONE TRAFFIC CONTROL SECTION.

Drawing No. 1101.02, Sheet 13, TEMPORARY LANE CLOSURES, replace General Note #12 with the following:

12- TRUCK MOUNTED CHANGEABLE MESSAGE SIGNS (TMCMS) USED ON SHADOW VEHICLES FOR “IN LANE” ACTIVITIES SHALL BE A MINIMUM OF 43" X 73". THE DISPLAY PANEL SHALL HAVE FULL MATRIX CAPABILITY WITH THE CAPABILITY TO PROVIDE 2 MESSAGE LINES WITH 7 CHARACTERS PER LINE WITH A MINIMUM CHARACTER HEIGHT OF 18". FOR ADDITIONAL MESSAGING, CONTACT THE WORK ZONE TRAFFIC CONTROL SECTION.

13- TMCMS USED FOR ADVANCED WARNING ON VEHICLES LOCATED ON THE SHOULDER MAY BE SMALLER THAN 43" X 73". THE DISPLAY PANEL SHALL HAVE THE CAPABILITY TO PROVIDE 2 MESSAGE LINES WITH 7 CHARACTERS PER LINE WITH A MINIMUM CHARACTER HEIGHT OF 18". FOR ADDITIONAL MESSAGING, CONTACT THE WORK ZONE TRAFFIC CONTROL SECTION.

GROUT REFERENCES FOR POSITIVE PROTECTION:

(5-19-15)

1170

SP11 R20

Revise the 2012 *Standard Specifications* as follows:

Page 11-14, Article 1170-2, Materials, line 30, in the materials table, replace “Freeze-Thaw Durable Grout, Nonshrink” with “Grout, Type 3”.

Page 11-14, Article 1170-2, Materials, lines 31-32, delete the first paragraph after the materials table.

STANDARD SPECIAL PROVISION
AVAILABILITY OF FUNDS – TERMINATION OF CONTRACTS

(5-20-08)

Z-2

General Statute 143C-6-11. (h) Highway Appropriation is hereby incorporated verbatim in this contract as follows:

(h) Amounts Encumbered. – Transportation project appropriations may be encumbered in the amount of allotments made to the Department of Transportation by the Director for the estimated payments for transportation project contract work to be performed in the appropriation fiscal year. The allotments shall be multiyear allotments and shall be based on estimated revenues and shall be subject to the maximum contract authority contained in *General Statute 143C-6-11(c)*. Payment for transportation project work performed pursuant to contract in any fiscal year other than the current fiscal year is subject to appropriations by the General Assembly. Transportation project contracts shall contain a schedule of estimated completion progress, and any acceleration of this progress shall be subject to the approval of the Department of Transportation provided funds are available. The State reserves the right to terminate or suspend any transportation project contract, and any transportation project contract shall be so terminated or suspended if funds will not be available for payment of the work to be performed during that fiscal year pursuant to the contract. In the event of termination of any contract, the contractor shall be given a written notice of termination at least 60 days before completion of scheduled work for which funds are available. In the event of termination, the contractor shall be paid for the work already performed in accordance with the contract specifications.

Payment will be made on any contract terminated pursuant to the special provision in accordance with Subarticle 108-13(E) of the *2012 Standard Specifications*.

STANDARD SPECIAL PROVISION
NCDOT GENERAL SEED SPECIFICATION FOR SEED QUALITY

(5-17-11)

Z-3

Seed shall be sampled and tested by the North Carolina Department of Agriculture and Consumer Services, Seed Testing Laboratory. When said samples are collected, the vendor shall supply an independent laboratory report for each lot to be tested. Results from seed so sampled shall be final. Seed not meeting the specifications shall be rejected by the Department of Transportation and shall not be delivered to North Carolina Department of Transportation warehouses. If seed has been delivered it shall be available for pickup and replacement at the supplier's expense.

Any re-labeling required by the North Carolina Department of Agriculture and Consumer Services, Seed Testing Laboratory, that would cause the label to reflect as otherwise specified herein shall be rejected by the North Carolina Department of Transportation.

Seed shall be free from seeds of the noxious weeds Johnsongrass, Balloonvine, Jimsonweed, Witchweed, Itchgrass, Serrated Tussock, Showy Crotalaria, Smooth Crotalaria, Sicklepod, Sandbur, Wild Onion, and Wild Garlic. Seed shall not be labeled with the above weed species on the seed analysis label. Tolerances as applied by the Association of Official Seed Analysts will NOT be allowed for the above noxious weeds except for Wild Onion and Wild Garlic.

Tolerances established by the Association of Official Seed Analysts will generally be recognized. However, for the purpose of figuring pure live seed, the found pure seed and found germination percentages as reported by the North Carolina Department of Agriculture and Consumer Services, Seed Testing Laboratory will be used. Allowances, as established by the NCDOT, will be recognized for minimum pure live seed as listed on the following pages.

The specifications for restricted noxious weed seed refers to the number per pound as follows:

| <u>Restricted Noxious Weed</u> | <u>Limitations per Lb. Of Seed</u> | <u>Restricted Noxious Weed</u> | <u>Limitations per Lb. of Seed</u> |
|---------------------------------------|-------------------------------------------|---------------------------------------|-------------------------------------------|
| Blessed Thistle | 4 seeds | Cornflower Robin) | (Ragged 27 seeds |
| Cocklebur | 4 seeds | Texas Panicum | 27 seeds |
| Spurred Anoda | 4 seeds | Bracted Plantain | 54 seeds |
| Velvetleaf | 4 seeds | Buckhorn Plantain | 54 seeds |
| Morning-glory | 8 seeds | Broadleaf Dock | 54 seeds |
| Corn Cockle | 10 seeds | Curly Dock | 54 seeds |
| Wild Radish | 12 seeds | Dodder | 54 seeds |
| Purple Nutsedge | 27 seeds | Giant Foxtail | 54 seeds |
| Yellow Nutsedge | 27 seeds | Horsenettle | 54 seeds |
| Canada Thistle | 27 seeds | Quackgrass | 54 seeds |
| Field Bindweed | 27 seeds | Wild Mustard | 54 seeds |
| Hedge Bindweed | 27 seeds | | |

Seed of Pensacola Bahiagrass shall not contain more than 7% inert matter, Kentucky Bluegrass, Centipede and Fine or Hard Fescue shall not contain more than 5% inert matter whereas a maximum of 2% inert matter will be allowed on all other kinds of seed. In addition, all seed shall not contain more than 2% other crop seed nor more than 1% total weed seed. The germination rate as tested by the North Carolina Department of Agriculture shall not fall below 70%, which includes both dormant and hard seed. Seed shall be labeled with not more than 7%, 5% or 2% inert matter (according to above specifications), 2% other crop seed and 1% total weed seed.

Exceptions may be made for minimum pure live seed allowances when cases of seed variety shortages are verified. Pure live seed percentages will be applied in a verified shortage situation. Those purchase orders of deficient seed lots will be credited with the percentage that the seed is deficient.

FURTHER SPECIFICATIONS FOR EACH SEED GROUP ARE GIVEN BELOW:

Minimum 85% pure live seed; maximum 1% total weed seed; maximum 2% total other crop seed; maximum 144 restricted noxious weed seed per pound. Seed less than 83% pure live seed will not be approved.

Sericea Lespedeza
Oats (seeds)

Minimum 80% pure live seed; maximum 1% total weed seed; maximum 2% total other crop; maximum 144 restricted noxious weed seed per pound. Seed less than 78% pure live seed will not be approved.

| | |
|--------------------------------------|----------------------------|
| Tall Fescue (all approved varieties) | Bermudagrass |
| Kobe Lespedeza | Browntop Millet |
| Korean Lespedeza | German Millet – Strain R |
| Weeping Lovegrass | Clover – Red/White/Crimson |
| Carpetgrass | |

Minimum 78% pure live seed; maximum 1% total weed seed; maximum 2% total other crop seed; maximum 144 restricted noxious weed seed per pound. Seed less than 76% pure live seed will not be approved.

Common or Sweet Sundangrass

Minimum 76% pure live seed; maximum 1% total weed seed; maximum 2% total other crop seed; maximum 144 restricted noxious weed seed per pound. Seed less than 74% pure live seed will not be approved.

Rye (grain; all varieties)
Kentucky Bluegrass (all approved varieties)
Hard Fescue (all approved varieties)
Shrub (bicolor) Lespedeza

Minimum 70% pure live seed; maximum 1% total weed seed; maximum 2% total other crop seed; maximum 144 noxious weed seed per pound. Seed less than 70% pure live seed will not be approved.

| | |
|----------------------|-------------------|
| Centipedegrass | Japanese Millet |
| Crownvetch | Reed Canary Grass |
| Pensacola Bahiagrass | Zoysia |
| Creeping Red Fescue | |

Minimum 70% pure live seed; maximum 1% total weed seed; maximum 2% total other crop seed; maximum 5% inert matter; maximum 144 restricted noxious weed seed per pound.

Barnyard Grass
Big Bluestem
Little Bluestem
Bristly Locust
Birdsfoot Trefoil
Indiangrass
Orchardgrass
Switchgrass
Yellow Blossom Sweet Clover

STANDARD SPECIAL PROVISION**ERRATA**

(1-17-12) (Rev. 04-21-15)

Z-4

Revise the 2012 *Standard Specifications* as follows:

Division 2

Page 2-7, line 31, Article 215-2 Construction Methods, replace “Article 107-26” with “Article 107-25”.

Page 2-17, Article 226-3, Measurement and Payment, line 2, delete “pipe culverts,”.

Page 2-20, Subarticle 230-4(B), Contractor Furnished Sources, change references as follows:
Line 1, replace “(4) Buffer Zone” with “(c) Buffer Zone”; **Line 12**, replace “(5) Evaluation for Potential Wetlands and Endangered Species” with “(d) Evaluation for Potential Wetlands and Endangered Species”; and **Line 33**, replace “(6) Approval” with “(4) Approval”.

Division 3

Page 3-1, after line 15, Article 300-2 Materials, replace “1032-9(F)” with “1032-6(F)”.

Division 4

Page 4-77, line 27, Subarticle 452-3(C) Concrete Coping, replace “sheet pile” with “reinforcement”.

Division 6

Page 6-7, line 31, Article 609-3 Field Verification of Mixture and Job Mix Formula Adjustments, replace “30” with “45”.

Page 6-10, line 42, Subarticle 609-6(C)(2), replace “Subarticle 609-6(E)” with “Subarticle 609-6(D)”.

Page 6-11, Table 609-1 Control Limits, replace “Max. Spec. Limit” for the Target Source of $P_{0.075}/P_{be}$ Ratio with “1.0”.

Page 6-40, Article 650-2 Materials, replace “Subarticle 1012-1(F)” with “Subarticle 1012-1(E)”

Division 7

Page 7-1, Article 700-3, CONCRETE HAULING EQUIPMENT, line 33, replace “competition” with “completion”.

Division 8

Page 8-23, line 10, Article 838-2 Materials, replace “Portland Cement Concrete, Class B” with “Portland Cement Concrete, Class A”.

Division 10

Page 10-166, Article 1081-3 Hot Bitumen, replace “Table 1081-16” with “Table 1081-2”, replace “Table 1081-17” with “Table 1081-3”, and replace “Table 1081-18” with “Table 1081-4”.

Division 12

Page 12-7, Table 1205-3, add “FOR THERMOPLASTIC” to the end of the title.

Page 12-8, Subarticle 1205-5(B), line 13, replace “Table 1205-2” with “Table 1205-4”.

Page 12-8, Table 1205-4 and 1205-5, replace “THERMOPLASTIC” in the title of these tables with “POLYUREA”.

Page 12-9, Subarticle 1205-6(B), line 21, replace “Table 1205-4” with “Table 1205-6”.

Page 12-11, Subarticle 1205-8(C), line 25, replace “Table 1205-5” with “Table 1205-7”.

Division 15

Page 15-4, Subarticle 1505-3(F) Backfilling, line 26, replace “Subarticle 235-4(C)” with “Subarticle 235-3(C)”.

Page 15-6, Subarticle 1510-3(B), after line 21, replace the allowable leakage formula with the following: $W=LD\sqrt{P} \div 148,000$

Page 15-6, Subarticle 1510-3(B), line 32, delete “may be performed concurrently or” and replace with “shall be performed”.

Page 15-17, Subarticle 1540-3(E), line 27, delete “Type 1”.

Division 17

Page 17-26, line 42, Subarticle 1731-3(D) Termination and Splicing within Interconnect Center, delete this subarticle.

Revise the *2012 Roadway Standard Drawings* as follows:

1633.01 Sheet 1 of 1, English Standard Drawing for Matting Installation, replace “1633.01” with “1631.01”.

STANDARD SPECIAL PROVISION**PLANT AND PEST QUARANTINES****(Imported Fire Ant, Gypsy Moth, Witchweed, Emerald Ash Borer, And Other Noxious Weeds)**

(3-18-03) (Rev. 12-20-16)

Z-04a

Within Quarantined Area

This project may be within a county regulated for plant and/or pests. If the project or any part of the Contractor's operations is located within a quarantined area, thoroughly clean all equipment prior to moving out of the quarantined area. Comply with federal/state regulations by obtaining a certificate or limited permit for any regulated article moving from the quarantined area.

Originating in a Quarantined County

Obtain a certificate or limited permit issued by the N.C. Department of Agriculture/United States Department of Agriculture. Have the certificate or limited permit accompany the article when it arrives at the project site.

Contact

Contact the N.C. Department of Agriculture/United States Department of Agriculture at 1-800-206-9333, 919-707-3730, or <http://www.ncagr.gov/plantindustry/> to determine those specific project sites located in the quarantined area or for any regulated article used on this project originating in a quarantined county.

Regulated Articles Include

1. Soil, sand, gravel, compost, peat, humus, muck, and decomposed manure, separately or with other articles. This includes movement of articles listed above that may be associated with cut/waste, ditch pulling, and shoulder cutting.
2. Plants with roots including grass sod.
3. Plant crowns and roots.
4. Bulbs, corms, rhizomes, and tubers of ornamental plants.
5. Hay, straw, fodder, and plant litter of any kind.
6. Clearing and grubbing debris.
7. Used agricultural cultivating and harvesting equipment.
8. Used earth-moving equipment.
9. Any other products, articles, or means of conveyance, of any character, if determined by an inspector to present a hazard of spreading imported fire ant, gypsy moth, witchweed, emerald ash borer, or other noxious weeds.

STANDARD SPECIAL PROVISION**AWARD OF CONTRACT**

(6-28-77)(Rev 2/16/2016)

Z-6

“The North Carolina Department of Transportation, in accordance with the provisions of *Title VI of the Civil Rights Act of 1964* (78 Stat. 252) and the Regulations of the Department of Transportation (*49 C.F.R., Part 21*), issued pursuant to such act, hereby notifies all bidders that it will affirmatively insure that the contract entered into pursuant to this advertisement will be awarded to the lowest responsible bidder without discrimination on the ground of race, color, or national origin”.

TITLE VI AND NONDISCRIMINATION**I. Title VI Assurance**

During the performance of this contract, the contractor, for itself, its assignees and successors in interest (hereinafter referred to as the "contractor") agrees as follows:

(1) Compliance with Regulations: The contractor shall comply with the Regulation relative to nondiscrimination in Federally-assisted programs of the Department of Transportation (hereinafter, "DOT") Title 49, Code of Federal Regulations, Part 21, as they may be amended from time to time, (hereinafter referred to as the Regulations), which are herein incorporated by reference and made a part of this contract.

(2) Nondiscrimination: The Contractor, with regard to the work performed by it during the contract, shall not discriminate on the grounds of race, color, or national origin in the selection and retention of subcontractors, including procurements of materials and leases of equipment. The contractor shall not participate either directly or indirectly in the discrimination prohibited by section 21.5 of the Regulations, including employment practices when the contract covers a program set forth in Appendix B of the Regulations.

(3) Solicitations for Subcontractors, Including Procurements of Materials and Equipment: In all solicitations either by competitive bidding or negotiation made by the contractor for work to be performed under a subcontract, including procurements of materials or leases of equipment, each potential subcontractor or supplier shall be notified by the contractor of the contractor's obligations under this contract and the Regulations relative to nondiscrimination on the grounds of race, color, or national origin.

(4) Information and Reports: The contractor shall provide all information and reports required by the Regulations or directives issued pursuant thereto, and shall permit access to its books, records, accounts, other sources of information, and its facilities as may be determined by the North Carolina Department of Transportation (NCDOT) or the Federal Highway Administration (FHWA) to be pertinent to ascertain compliance with such Regulations, orders and instructions. Where any information required of a contractor is in the exclusive possession of another who fails or refuses to furnish this information the contractor shall so certify to the NCDOT, or the FHWA as appropriate, and shall set forth what efforts it has made to obtain the information.

(5) Sanctions for Noncompliance: In the event of the contractor's noncompliance with the nondiscrimination provisions of this contract, the NCDOT shall impose such contract sanctions as it or the FHWA may determine to be appropriate, including, but not limited to:

- (a) Withholding of payments to the contractor under the contract until the contractor complies, and/or
- (b) Cancellation, termination or suspension of the contract, in whole or in part.

(6) Incorporation of Provisions: The contractor shall include the provisions of paragraphs (1) through (6) in every subcontract, including procurements of materials and leases of equipment, unless exempt by the Regulations, or directives issued pursuant thereto.

The contractor shall take such action with respect to any subcontractor procurement as the NCDOT or the FHWA may direct as a means of enforcing such provisions including sanctions for noncompliance: provided, however, that, in the event a contractor becomes involved in, or is threatened with, litigation with a subcontractor or supplier as a result of such direction, the contractor may request the NCDOT to enter into such litigation to protect the interests of the NCDOT, and, in addition, the contractor may request the United States to enter into such litigation to protect the interests of the United States.

II. Title VI Nondiscrimination Program

Title VI of the 1964 Civil Rights Act, 42 U.S.C. 2000d, provides that: "No person in the United States shall, on the grounds of race, color, or national origin, be excluded from participation in, be denied the benefits of, or be subjected to discrimination under any program or activity receiving Federal financial assistance." The broader application of nondiscrimination law is found in other statutes, executive orders, and regulations (see Section III, Pertinent Nondiscrimination Authorities), which provide additional protections based on age, sex, disability and religion. In addition, the 1987 Civil Rights Restoration Act extends nondiscrimination coverage to all programs and activities of federal-aid recipients and contractors, including those that are not federally-funded.

Nondiscrimination Assurance

The North Carolina Department of Transportation (NCDOT) hereby gives assurance that no person shall on the ground of race, color, national origin, sex, age, and disability, be excluded from participation in, be denied the benefits of, or be otherwise subjected to discrimination under any program or activity conducted by the recipient, as provided by Title VI of the Civil Rights Act of 1964, the Civil Rights Restoration Act of 1987, and any other related Civil Rights authorities, whether those programs and activities are federally funded or not.

Obligation

During the performance of this contract, the Contractor and its subcontractors are responsible for complying with NCDOT's Title VI Program. The Contractor must ensure that NCDOT's Notice of Nondiscrimination is posted in conspicuous locations accessible to all employees and subcontractors on the jobsite, along with the Contractor's own Equal Employment Opportunity (EEO) Policy Statement. The Contractor shall physically incorporate this "**TITLE VI AND NONDISCRIMINATION**" language, in its entirety, into all its subcontracts on federally-assisted and state-funded NCDOT-owned projects, and ensure its inclusion by subcontractors into all subsequent lower tier subcontracts. The Contractor and its subcontractors shall also physically incorporate the **FHWA-1273**, in its entirety, into all subcontracts and subsequent lower tier subcontracts on Federal-aid highway construction contracts only. The Contractor is also

responsible for making its subcontractors aware of NCDOT's Discrimination Complaints Process, as follows:

FILING OF COMPLAINTS

1. **Applicability** – These complaint procedures apply to the beneficiaries of the NCDOT's programs, activities, and services, including, but not limited to, members of the public, contractors, subcontractors, consultants, and other sub-recipients of federal and state funds.
2. **Eligibility** – Any person or class of persons who believes he/she has been subjected to discrimination or retaliation prohibited by any of the Civil Rights authorities, based upon race, color, sex, age, national origin, or disability, may file a written complaint with NCDOT's Civil Rights office. The law prohibits intimidation or retaliation of any sort. The complaint may be filed by the affected individual or a representative, and must be in writing.
3. **Time Limits and Filing Options** – A complaint must be filed no later than 180 calendar days after the following:
 - The date of the alleged act of discrimination; or
 - The date when the person(s) became aware of the alleged discrimination; or
 - Where there has been a continuing course of conduct, the date on which that conduct was discontinued or the latest instance of the conduct.

Title VI and other discrimination complaints may be submitted to the following entities:

- **North Carolina Department of Transportation**, Office of Equal Opportunity & Workforce Services (EOWS), External Civil Rights Section, 1511 Mail Service Center, Raleigh, NC 27699-1511; 919-508-1808 or toll free 800-522-0453
 - **US Department of Transportation**, Departmental Office of Civil Rights, External Civil Rights Programs Division, 1200 New Jersey Avenue, SE, Washington, DC 20590; 202-366-4070
 - Federal Highway Administration**, North Carolina Division Office, 310 New Bern Avenue, Suite 410, Raleigh, NC 27601, 919-747-7010
 - Federal Highway Administration**, Office of Civil Rights, 1200 New Jersey Avenue, SE, 8th Floor, E81-314, Washington, DC 20590, 202-366-0693 / 366-0752
 - Federal Transit Administration**, Office of Civil Rights, ATTN: Title VI Program Coordinator, East Bldg. 5th Floor – TCR, 1200 New Jersey Avenue, SE, Washington, DC 20590
 - Federal Aviation Administration**, Office of Civil Rights, 800 Independence Avenue, SW, Washington, DC 20591, 202-267-3258
 - **US Department of Justice**, Special Litigation Section, Civil Rights Division, 950 Pennsylvania Avenue, NW, Washington, DC 20530, 202-514-6255 or toll free 877-218-5228
4. **Format for Complaints** – Complaints must be in **writing** and **signed** by the complainant(s) or a representative and include the complainant's name, address, and telephone number. Complaints received by fax or e-mail will be acknowledged and processed. Allegations received by telephone will be reduced to writing and provided to the complainant for confirmation or revision before processing. Complaints will be accepted in other languages including Braille.
 5. **Discrimination Complaint Form** – Contact NCDOT EOWS at the phone number above to receive a full copy of the Discrimination Complaint Form and procedures.

- 6. Complaint Basis** – Allegations must be based on issues involving race, color, national origin, sex, age, or disability. The term “basis” refers to the complainant’s membership in a protected group category. Contact this office to receive a Discrimination Complaint Form.

| Protected Categories | Definition | Examples | Applicable Statutes and Regulations | |
|----------------------|------------------------------------------------------------------------------------------------------------------------------------------------------------------------|------------------------------------------------------------------------------------------------------------------------|----------------------------------------------------------------------------------------|----------------------------------------------------------------------------|
| | | | FHWA | FTA |
| Race | An individual belonging to one of the accepted racial groups; or the perception, based usually on physical characteristics that a person is a member of a racial group | Black/African American, Hispanic/Latino, Asian, American Indian/Alaska Native, Native Hawaiian/Pacific Islander, White | Title VI of the Civil Rights Act of 1964; 49 CFR Part 21; 23 CFR 200 | Title VI of the Civil Rights Act of 1964; 49 CFR Part 21; Circular 4702.1B |
| Color | Color of skin, including shade of skin within a racial group | Black, White, brown, yellow, etc. | | |
| National Origin | Place of birth. Citizenship is not a factor. Discrimination based on language or a person’s accent is also covered. | Mexican, Cuban, Japanese, Vietnamese, Chinese | | |
| Sex | Gender | Women and Men | 1973 Federal-Aid Highway Act | Title IX of the Education Amendments of 1972 |
| Age | Persons of any age | 21 year old person | Age Discrimination Act of 1975 | |
| Disability | Physical or mental impairment, permanent or temporary, or perceived. | Blind, alcoholic, paraplegic, epileptic, diabetic, arthritic | Section 504 of the Rehabilitation Act of 1973; Americans with Disabilities Act of 1990 | |

III. Pertinent Nondiscrimination Authorities

During the performance of this contract, the contractor, for itself, its assignees, and successors in interest agrees to comply with the following non-discrimination statutes and authorities, including, but not limited to:

- Title VI of the Civil Rights Act of 1964 (42 U.S.C. § 2000d *et seq.*, 78 stat. 252), (prohibits discrimination on the basis of race, color, national origin); and 49 CFR Part 21.
- The Uniform Relocation Assistance and Real Property Acquisition Policies Act of 1970, (42 U.S.C. § 4601), (prohibits unfair treatment of persons displaced or whose property has been acquired because of Federal or Federal-aid programs and projects);
- Federal-Aid Highway Act of 1973, (23 U.S.C. § 324 *et seq.*), (prohibits discrimination on the basis of sex);
- Section 504 of the Rehabilitation Act of 1973, (29 U.S.C. § 794 *et seq.*), as amended, (prohibits discrimination on the basis of disability); and 49 CFR Part 27;

- The Age Discrimination Act of 1975, as amended, (42 U.S.C. § 6101 *et seq.*), (prohibits discrimination on the basis of age);
- Airport and Airway Improvement Act of 1982, (49 USC § 471, Section 47123), as amended, (prohibits discrimination based on race, creed, color, national origin, or sex);
- The Civil Rights Restoration Act of 1987, (PL 100-209), (Broadened the scope, coverage and applicability of Title VI of the Civil Rights Act of 1964, The Age Discrimination Act of 1975 and Section 504 of the Rehabilitation Act of 1973, by expanding the definition of the terms “programs or activities” to include all of the programs or activities of the Federal-aid recipients, sub-recipients and contractors, whether such programs or activities are Federally funded or not);
- Titles II and III of the Americans with Disabilities Act, which prohibit discrimination on the basis of disability in the operation of public entities, public and private transportation systems, places of public accommodation, and certain testing entities (42 U.S.C. §§ 12131 – 12189) as implemented by Department of Transportation regulations at 49 C.F.R. parts 37 and 38;
- The Federal Aviation Administration’s Non-discrimination statute (49 U.S.C. § 47123) (prohibits discrimination on the basis of race, color, national origin, and sex);
- Executive Order 12898, Federal Actions to Address Environmental Justice in Minority Populations and Low-Income Populations, which ensures discrimination against minority populations by discouraging programs, policies, and activities with disproportionately high and adverse human health or environmental effects on minority and low-income populations;
- Executive Order 13166, Improving Access to Services for Persons with Limited English Proficiency, and resulting agency guidance, national origin discrimination includes discrimination because of limited English proficiency (LEP). To ensure compliance with Title VI, you must take reasonable steps to ensure that LEP persons have meaningful access to your programs (70 Fed. Reg. at 74087 to 74100);
- Title IX of the Education Amendments of 1972, as amended, which prohibits you from discriminating because of sex in education programs or activities (20 U.S.C. 1681 *et seq.*).
- Title VII of the Civil Rights Act of 1964 (42 U.S.C. § 2000e *et seq.*, Pub. L. 88-352), (prohibits employment discrimination on the basis of race, color, religion, sex, or national origin);
- 49 CFR Part 26, regulation to ensure nondiscrimination in the award and administration of DOT-assisted contracts in the Department's highway, transit, and airport financial assistance programs, as regards the use of Disadvantaged Business Enterprises (DBEs);
- Form FHWA-1273, “Required Contract Provisions,” a collection of contract provisions and proposal notices that are generally applicable to *all Federal-aid construction projects* and must be made a part of, and physically incorporated into, *all federally-assisted contracts*, as well as appropriate subcontracts and purchase orders, particularly Sections II (Nondiscrimination) and III (Nonsegregated Facilities).

STANDARD SPECIAL PROVISION**MINORITY AND FEMALE EMPLOYMENT REQUIREMENTS**

Z-7

NOTICE OF REQUIREMENTS FOR AFFIRMATIVE ACTION TO ENSURE EQUAL EMPLOYMENT OPPORTUNITY (*EXECUTIVE NUMBER 11246*)

1. The goals and timetables for minority and female participation, expressed in percentage terms for the Contractor's aggregate workforce in each trade on all construction work in the covered area, see as shown on the attached sheet entitled "Employment Goals for Minority and Female participation".

These goals are applicable to all the Contractor's construction work (whether or not it is Federal or federally assisted) performed in the covered area. If the Contractor performs construction work in a geographical area located outside of the covered area, it shall apply the goals established for such geographical area where the work is actually performed. With regard to this second area, the Contractor also is subject to the goals for both its federally involved and nonfederally involved construction.

The Contractor's compliance with the Executive Order and the regulations in *41 CFR Part 60-4* shall be based on its implementation of the Equal Opportunity Clause, specific affirmative action obligations required by the specifications set forth in *41 CFR 60-4.3(a)*, and its effort to meet the goals. The hours of minority and female employment and training must be substantially uniform throughout the length of the contract, and in each trade and the Contractor shall make a good faith effort to employ minorities and women evenly on each of its projects. The transfer of minority or female employees or trainees from Contractor to Contractor or from project to project or the sole purpose of meeting the Contractor's goals shall be a violation of the contract, the executive Order and the regulations in *41 CFR Part 60-4*. Compliance with the goals will be measured against the total work hours performed.

2. As used in this Notice and in the contract resulting from this solicitation, the "covered area" is the county or counties shown on the cover sheet of the proposal form and contract.

**EMPLOYMENT GOALS FOR MINORITY
AND FEMALE PARTICIPATION**

Economic Areas

Area 023 29.7%

Bertie County
Camden County
Chowan County
Gates County
Hertford County
Pasquotank County
Perquimans County

Area 024 31.7%

Beaufort County
Carteret County
Craven County
Dare County
Edgecombe County
Green County
Halifax County
Hyde County
Jones County
Lenoir County
Martin County
Nash County
Northampton County
Pamlico County
Pitt County
Tyrrell County
Washington County
Wayne County
Wilson County

Area 025 23.5%

Columbus County
Duplin County
Onslow County
Pender County

Area 026 33.5%

Bladen County
Hoke County
Richmond County
Robeson County
Sampson County
Scotland County

Area 027 24.7%

Chatham County
Franklin County
Granville County
Harnett County
Johnston County
Lee County
Person County
Vance County
Warren County

Area 028 15.5%

Alleghany County
Ashe County
Caswell County
Davie County
Montgomery County
Moore County
Rockingham County
Surry County
Watauga County
Wilkes County

Area 029 15.7%

Alexander County
Anson County
Burke County
Cabarrus County
Caldwell County
Catawba County
Cleveland County
Iredell County
Lincoln County
Polk County
Rowan County
Rutherford County
Stanly County

Area 0480 8.5%

Buncombe County
Madison County

Area 030 6.3%

Avery County
Cherokee County
Clay County
Graham County
Haywood County
Henderson County
Jackson County
McDowell County
Macon County
Mitchell County
Swain County
Transylvania County
Yancey County

SMSA Areas

Area 5720 26.6%

Currituck County

Area 9200 20.7%

Brunswick County

New Hanover County

Area 2560 24.2%

Cumberland County

Area 6640 22.8%

Durham County

Orange County

Wake County

Area 1300 16.2%

Alamance County

Area 3120 16.4%

Davidson County

Forsyth County

Guilford County

Randolph County

Stokes County

Yadkin County

Area 1520 18.3%

Gaston County

Mecklenburg County

Union County

Goals for Female

Participation in Each Trade

(Statewide) 6.9%

STANDARD SPECIAL PROVISION**REQUIRED CONTRACT PROVISIONS FEDERAL - AID CONSTRUCTION CONTRACTS**

FHWA - 1273 Electronic Version - May 1, 2012

Z-8

- I. General
- II. Nondiscrimination
- III. Nonsegregated Facilities
- IV. Davis-Bacon and Related Act Provisions
- V. Contract Work Hours and Safety Standards Act Provisions
- VI. Subletting or Assigning the Contract
- VII. Safety: Accident Prevention
- VIII. False Statements Concerning Highway Projects
- IX. Implementation of Clean Air Act and Federal Water Pollution Control Act
- X. Compliance with Governmentwide Suspension and Debarment Requirements
- XI. Certification Regarding Use of Contract Funds for Lobbying

ATTACHMENTS

- A. Employment and Materials Preference for Appalachian Development Highway System or Appalachian Local Access Road Contracts (included in Appalachian contracts only)

I. GENERAL

1. Form FHWA-1273 must be physically incorporated in each construction contract funded under Title 23 (excluding emergency contracts solely intended for debris removal). The contractor (or subcontractor) must insert this form in each subcontract and further require its inclusion in all lower tier subcontracts (excluding purchase orders, rental agreements and other agreements for supplies or services).
The applicable requirements of Form FHWA-1273 are incorporated by reference for work done under any purchase order, rental agreement or agreement for other services. The prime contractor shall be responsible for compliance by any subcontractor, lower-tier subcontractor or service provider.
Form FHWA-1273 must be included in all Federal-aid design-build contracts, in all subcontracts and in lower tier subcontracts (excluding subcontracts for design services, purchase orders, rental agreements and other agreements for supplies or services). The design-builder shall be responsible for compliance by any subcontractor, lower-tier subcontractor or service provider.
Contracting agencies may reference Form FHWA-1273 in bid proposal or request for proposal documents, however, the Form FHWA-1273 must be physically incorporated (not referenced) in all contracts, subcontracts and lower-tier subcontracts (excluding purchase orders, rental agreements and other agreements for supplies or services related to a construction contract).
2. Subject to the applicability criteria noted in the following sections, these contract provisions shall apply to all work performed on the contract by the contractor's own organization and with the assistance of workers under the contractor's immediate superintendence and to all work performed on the contract by piecework, station work, or by subcontract.
3. A breach of any of the stipulations contained in these Required Contract Provisions may be sufficient grounds for withholding of progress payments, withholding of final payment, termination of the contract, suspension / debarment or any other action determined to be appropriate by the contracting agency and FHWA.
4. Selection of Labor: During the performance of this contract, the contractor shall not use convict labor for any purpose within the limits of a construction project on a Federal-aid highway unless it is labor performed by convicts who are on parole, supervised release, or probation. The term Federal-aid highway does not include roadways functionally classified as local roads or rural minor collectors.

II. NONDISCRIMINATION

The provisions of this section related to 23 CFR Part 230 are applicable to all Federal-aid construction contracts and to all related construction subcontracts of \$10,000 or more. The provisions of 23 CFR Part 230 are not applicable to material supply, engineering, or architectural service contracts.

In addition, the contractor and all subcontractors must comply with the following policies: Executive Order 11246, 41 CFR 60, 29 CFR 1625-1627, Title 23 USC Section 140, the Rehabilitation Act of 1973, as amended (29 USC 794), Title VI of the Civil Rights Act of 1964, as amended, and related regulations including 49 CFR Parts 21, 26 and 27; and 23 CFR Parts 200, 230, and 633.

The contractor and all subcontractors must comply with: the requirements of the Equal Opportunity Clause in 41 CFR 60-1.4(b) and, for all construction contracts exceeding \$10,000, the Standard Federal Equal Employment Opportunity Construction Contract Specifications in 41 CFR 60-4.3.

Note: The U.S. Department of Labor has exclusive authority to determine compliance with Executive Order 11246 and the policies of the Secretary of Labor including 41 CFR 60, and 29 CFR 1625-1627. The contracting agency and the FHWA have the authority and the responsibility to ensure compliance with Title 23 USC Section 140, the Rehabilitation Act of 1973, as amended (29 USC 794), and Title VI of the Civil Rights Act of 1964, as amended, and related regulations including 49 CFR Parts 21, 26 and 27; and 23 CFR Parts 200, 230, and 633.

The following provision is adopted from 23 CFR 230, Appendix A, with appropriate revisions to conform to the U.S. Department of Labor (US DOL) and FHWA requirements.

1. **Equal Employment Opportunity:** Equal employment opportunity (EEO) requirements not to discriminate and to take affirmative action to assure equal opportunity as set forth under laws, executive orders, rules, regulations (28 CFR 35, 29 CFR 1630, 29 CFR 1625-1627, 41 CFR 60 and 49 CFR 27) and orders of the Secretary of Labor as modified by the provisions prescribed herein, and imposed pursuant to 23 U.S.C. 140 shall constitute the EEO and specific affirmative action standards for the contractor's project activities under this contract. The provisions of the Americans with Disabilities Act of 1990 (42 U.S.C. 12101 et seq.) set forth under 28 CFR 35 and 29 CFR 1630 are incorporated by reference in this contract. In the execution of this contract, the contractor agrees to comply with the following minimum specific requirement activities of EEO:

- a. The contractor will work with the contracting agency and the Federal Government to ensure that it has made every good faith effort to provide equal opportunity with respect to all of its terms and conditions of employment and in their review of activities under the contract.
- b. The contractor will accept as its operating policy the following statement:
"It is the policy of this Company to assure that applicants are employed, and that employees are treated during employment, without regard to their race, religion, sex, color, national origin, age or disability. Such action shall include: employment, upgrading, demotion, or transfer; recruitment or recruitment advertising; layoff or termination; rates of pay or other forms of compensation; and selection for training, including apprenticeship, pre-apprenticeship, and/or on-the-job training."
2. **EEO Officer:** The contractor will designate and make known to the contracting officers an EEO Officer who will have the responsibility for and must be capable of effectively administering and promoting an active EEO program and who must be assigned adequate authority and responsibility to do so.
3. **Dissemination of Policy:** All members of the contractor's staff who are authorized to hire, supervise, promote, and discharge employees, or who recommend such action, or who are substantially involved in such action, will be made fully cognizant of, and will implement, the contractor's EEO policy and contractual responsibilities to provide EEO in each grade and classification of employment. To ensure that the above agreement will be met, the following actions will be taken as a minimum:
 - a. Periodic meetings of supervisory and personnel office employees will be conducted before the start of work and then not less often than once every six months, at which time the contractor's EEO policy and its implementation will be reviewed and explained. The meetings will be conducted by the EEO Officer.
 - b. All new supervisory or personnel office employees will be given a thorough indoctrination by the EEO Officer, covering all major aspects of the contractor's EEO obligations within thirty days following their reporting for duty with the contractor.
 - c. All personnel who are engaged in direct recruitment for the project will be instructed by the EEO Officer in the contractor's procedures for locating and hiring minorities and women.
 - d. Notices and posters setting forth the contractor's EEO policy will be placed in areas readily accessible to employees, applicants for employment and potential employees.
 - e. The contractor's EEO policy and the procedures to implement such policy will be brought to the attention of employees by means of meetings, employee handbooks, or other appropriate means.
4. **Recruitment:** When advertising for employees, the contractor will include in all advertisements for employees the notation: "An Equal Opportunity Employer." All such advertisements will be placed in publications having a large circulation among minorities and women in the area from which the project work force would normally be derived.
 - a. The contractor will, unless precluded by a valid bargaining agreement, conduct systematic and direct recruitment through public and private employee referral sources likely to yield qualified minorities and women. To meet this requirement, the contractor will identify sources of potential minority group employees, and establish with such identified sources procedures whereby minority and women applicants may be referred to the contractor for employment consideration.
 - b. In the event the contractor has a valid bargaining agreement providing for exclusive hiring hall referrals, the contractor is expected to observe the provisions of that agreement to the extent that the system meets the contractor's compliance with EEO contract provisions. Where implementation of such an agreement has the effect of discriminating against minorities or women, or obligates the contractor to do the same, such implementation violates Federal nondiscrimination provisions.
 - c. The contractor will encourage its present employees to refer minorities and women as applicants for employment. Information and procedures with regard to referring such applicants will be discussed with employees.
5. **Personnel Actions:** Wages, working conditions, and employee benefits shall be established and administered, and personnel actions of every type, including hiring, upgrading, promotion, transfer, demotion, layoff, and termination, shall be taken without regard to race, color, religion, sex, national origin, age or disability. The following procedures shall be followed:
 - a. The contractor will conduct periodic inspections of project sites to insure that working conditions and employee facilities do not indicate discriminatory treatment of project site personnel.
 - b. The contractor will periodically evaluate the spread of wages paid within each classification to determine any evidence of discriminatory wage practices.
 - c. The contractor will periodically review selected personnel actions in depth to determine whether there is evidence of discrimination. Where evidence is found, the contractor will promptly take corrective action. If the review indicates that the discrimination may extend beyond the actions reviewed, such corrective action shall include all affected persons.
 - d. The contractor will promptly investigate all complaints of alleged discrimination made to the contractor in connection with its obligations under this contract, will attempt to resolve such complaints, and will take appropriate corrective action within a reasonable time. If the investigation indicates that the discrimination may affect persons other than the complainant, such corrective action shall include such other persons. Upon completion of each investigation, the contractor will inform every complainant of all of their avenues of appeal.
6. **Training and Promotion:**
 - a. The contractor will assist in locating, qualifying, and increasing the skills of minorities and women who are applicants for employment or current employees. Such efforts should be aimed at developing full journey level status employees in the type of trade or job classification involved.
 - b. Consistent with the contractor's work force requirements and as permissible under Federal and State regulations, the contractor shall make full use of training programs, i.e., apprenticeship, and on-the-job training programs for the geographical area of contract performance. In the event a special provision for training is provided under this contract, this subparagraph will be superseded as indicated in the special provision. The contracting agency may reserve training positions for persons who receive welfare assistance in accordance with 23 U.S.C. 140(a).
 - c. The contractor will advise employees and applicants for employment of available training programs and entrance requirements for each.
 - d. The contractor will periodically review the training and promotion potential of employees who are minorities and women and will encourage eligible employees to apply for such training and promotion.

7. **Unions:** If the contractor relies in whole or in part upon unions as a source of employees, the contractor will use good faith efforts to obtain the cooperation of such unions to increase opportunities for minorities and women. Actions by the contractor, either directly or through a contractor's association acting as agent, will include the procedures set forth below:
 - a. The contractor will use good faith efforts to develop, in cooperation with the unions, joint training programs aimed toward qualifying more minorities and women for membership in the unions and increasing the skills of minorities and women so that they may qualify for higher paying employment.
 - b. The contractor will use good faith efforts to incorporate an EEO clause into each union agreement to the end that such union will be contractually bound to refer applicants without regard to their race, color, religion, sex, national origin, age or disability.
 - c. The contractor is to obtain information as to the referral practices and policies of the labor union except that to the extent such information is within the exclusive possession of the labor union and such labor union refuses to furnish such information to the contractor, the contractor shall so certify to the contracting agency and shall set forth what efforts have been made to obtain such information.
 - d. In the event the union is unable to provide the contractor with a reasonable flow of referrals within the time limit set forth in the collective bargaining agreement, the contractor will, through independent recruitment efforts, fill the employment vacancies without regard to race, color, religion, sex, national origin, age or disability; making full efforts to obtain qualified and/or qualifiable minorities and women. The failure of a union to provide sufficient referrals (even though it is obligated to provide exclusive referrals under the terms of a collective bargaining agreement) does not relieve the contractor from the requirements of this paragraph. In the event the union referral practice prevents the contractor from meeting the obligations pursuant to Executive Order 11246, as amended, and these special provisions, such contractor shall immediately notify the contracting agency.
8. **Reasonable Accommodation for Applicants / Employees with Disabilities:** The contractor must be familiar with the requirements for and comply with the Americans with Disabilities Act and all rules and regulations established there under. Employers must provide reasonable accommodation in all employment activities unless to do so would cause an undue hardship.
9. **Selection of Subcontractors, Procurement of Materials and Leasing of Equipment:** The contractor shall not discriminate on the grounds of race, color, religion, sex, national origin, age or disability in the selection and retention of subcontractors, including procurement of materials and leases of equipment. The contractor shall take all necessary and reasonable steps to ensure nondiscrimination in the administration of this contract.
 - a. The contractor shall notify all potential subcontractors and suppliers and lessors of their EEO obligations under this contract.
 - b. The contractor will use good faith efforts to ensure subcontractor compliance with their EEO obligations.
10. **Assurance Required by 49 CFR 26.13(b):**
 - a. The requirements of 49 CFR Part 26 and the State DOT's U.S. DOT-approved DBE program are incorporated by reference.
 - b. The contractor or subcontractor shall not discriminate on the basis of race, color, national origin, or sex in the performance of this contract. The contractor shall carry out applicable requirements of 49 CFR Part 26 in the award and administration of DOT-assisted contracts. Failure by the contractor to carry out these requirements is a material breach of this contract, which may result in the termination of this contract or such other remedy as the contracting agency deems appropriate.
11. **Records and Reports:** The contractor shall keep such records as necessary to document compliance with the EEO requirements. Such records shall be retained for a period of three years following the date of the final payment to the contractor for all contract work and shall be available at reasonable times and places for inspection by authorized representatives of the contracting agency and the FHWA.
 - a. The records kept by the contractor shall document the following:
 - (1) The number and work hours of minority and non-minority group members and women employed in each work classification on the project;
 - (2) The progress and efforts being made in cooperation with unions, when applicable, to increase employment opportunities for minorities and women; and
 - (3) The progress and efforts being made in locating, hiring, training, qualifying, and upgrading minorities and women;
 - b. The contractors and subcontractors will submit an annual report to the contracting agency each July for the duration of the project, indicating the number of minority, women, and non-minority group employees currently engaged in each work classification required by the contract work. This information is to be reported on Form FHWA-1391. The staffing data should represent the project work force on board in all or any part of the last payroll period preceding the end of July. If on-the-job training is being required by special provision, the contractor will be required to collect and report training data. The employment data should reflect the work force on board during all or any part of the last payroll period preceding the end of July.

III. NONSEGREGATED FACILITIES

This provision is applicable to all Federal-aid construction contracts and to all related construction subcontracts of \$10,000 or more.

The contractor must ensure that facilities provided for employees are provided in such a manner that segregation on the basis of race, color, religion, sex, or national origin cannot result. The contractor may neither require such segregated use by written or oral policies nor tolerate such use by employee custom. The contractor's obligation extends further to ensure that its employees are not assigned to perform their services at any location, under the contractor's control, where the facilities are segregated. The term "facilities" includes waiting rooms, work areas, restaurants and other eating areas, time clocks, restrooms, washrooms, locker rooms, and other storage or dressing areas, parking lots, drinking fountains, recreation or entertainment areas, transportation, and housing provided for employees. The contractor shall provide separate or single-user restrooms and necessary dressing or sleeping areas to assure privacy between sexes.

IV. DAVIS-BACON AND RELATED ACT PROVISIONS

This section is applicable to all Federal-aid construction projects exceeding \$2,000 and to all related subcontracts and lower-tier subcontracts (regardless of subcontract size). The requirements apply to all projects located within the right-of-way of a roadway that is functionally classified as Federal-aid highway. This excludes roadways functionally classified as local roads or rural minor collectors, which are exempt. Contracting agencies may elect to apply these requirements to other projects.

The following provisions are from the U.S. Department of Labor regulations in 29 CFR 5.5 "Contract provisions and related matters" with minor revisions to conform to the FHWA-1273 format and FHWA program requirements.

1. Minimum wages

- a. All laborers and mechanics employed or working upon the site of the work, will be paid unconditionally and not less often than once a week, and without subsequent deduction or rebate on any account (except such payroll deductions as are permitted by regulations issued by the Secretary of Labor under the Copeland Act (29 CFR part 3)), the full amount of wages and bona fide fringe benefits (or cash equivalents

thereof) due at time of payment computed at rates not less than those contained in the wage determination of the Secretary of Labor which is attached hereto and made a part hereof, regardless of any contractual relationship which may be alleged to exist between the contractor and such laborers and mechanics.

Contributions made or costs reasonably anticipated for bona fide fringe benefits under section 1(b)(2) of the Davis-Bacon Act on behalf of laborers or mechanics are considered wages paid to such laborers or mechanics, subject to the provisions of paragraph 1.d. of this section; also, regular contributions made or costs incurred for more than a weekly period (but not less often than quarterly) under plans, funds, or programs which cover the particular weekly period, are deemed to be constructively made or incurred during such weekly period. Such laborers and mechanics shall be paid the appropriate wage rate and fringe benefits on the wage determination for the classification of work actually performed, without regard to skill, except as provided in 29 CFR 5.5(a)(4). Laborers or mechanics performing work in more than one classification may be compensated at the rate specified for each classification for the time actually worked therein: Provided, That the employer's payroll records accurately set forth the time spent in each classification in which work is performed. The wage determination (including any additional classification and wage rates conformed under paragraph 1.b. of this section) and the Davis-Bacon poster (WH-1321) shall be posted at all times by the contractor and its subcontractors at the site of the work in a prominent and accessible place where it can be easily seen by the workers.

- b. (1) The contracting officer shall require that any class of laborers or mechanics, including helpers, which is not listed in the wage determination and which is to be employed under the contract shall be classified in conformance with the wage determination. The contracting officer shall approve an additional classification and wage rate and fringe benefits therefore only when the following criteria have been met:
 - (i) The work to be performed by the classification requested is not performed by a classification in the wage determination; and
 - (ii) The classification is utilized in the area by the construction industry; and
 - (iii) The proposed wage rate, including any bona fide fringe benefits, bears a reasonable relationship to the wage rates contained in the wage determination.
 - (2) If the contractor and the laborers and mechanics to be employed in the classification (if known), or their representatives, and the contracting officer agree on the classification and wage rate (including the amount designated for fringe benefits where appropriate), a report of the action taken shall be sent by the contracting officer to the Administrator of the Wage and Hour Division, Employment Standards Administration, U.S. Department of Labor, Washington, DC 20210. The Administrator, or an authorized representative, will approve, modify, or disapprove every additional classification action within 30 days of receipt and so advise the contracting officer or will notify the contracting officer within the 30-day period that additional time is necessary.
 - (3) In the event the contractor, the laborers or mechanics to be employed in the classification or their representatives, and the contracting officer do not agree on the proposed classification and wage rate (including the amount designated for fringe benefits, where appropriate), the contracting officer shall refer the questions, including the views of all interested parties and the recommendation of the contracting officer, to the Wage and Hour Administrator for determination. The Wage and Hour Administrator, or an authorized representative, will issue a determination within 30 days of receipt and so advise the contracting officer or will notify the contracting officer within the 30-day period that additional time is necessary.
 - (4) The wage rate (including fringe benefits where appropriate) determined pursuant to paragraphs 1.b.(2) or 1.b.(3) of this section, shall be paid to all workers performing work in the classification under this contract from the first day on which work is performed in the classification.
 - c. Whenever the minimum wage rate prescribed in the contract for a class of laborers or mechanics includes a fringe benefit which is not expressed as an hourly rate, the contractor shall either pay the benefit as stated in the wage determination or shall pay another bona fide fringe benefit or an hourly cash equivalent thereof.
 - d. If the contractor does not make payments to a trustee or other third person, the contractor may consider as part of the wages of any laborer or mechanic the amount of any costs reasonably anticipated in providing bona fide fringe benefits under a plan or program, Provided, That the Secretary of Labor has found, upon the written request of the contractor, that the applicable standards of the Davis-Bacon Act have been met. The Secretary of Labor may require the contractor to set aside in a separate account assets for the meeting of obligations under the plan or program.
2. **Withholding.** The contracting agency shall upon its own action or upon written request of an authorized representative of the Department of Labor, withhold or cause to be withheld from the contractor under this contract, or any other Federal contract with the same prime contractor, or any other federally-assisted contract subject to Davis-Bacon prevailing wage requirements, which is held by the same prime contractor, so much of the accrued payments or advances as may be considered necessary to pay laborers and mechanics, including apprentices, trainees, and helpers, employed by the contractor or any subcontractor the full amount of wages required by the contract. In the event of failure to pay any laborer or mechanic, including any apprentice, trainee, or helper, employed or working on the site of the work, all or part of the wages required by the contract, the contracting agency may, after written notice to the contractor, take such action as may be necessary to cause the suspension of any further payment, advance, or guarantee of funds until such violations have ceased.
 3. **Payrolls and basic records**
 - a. Payrolls and basic records relating thereto shall be maintained by the contractor during the course of the work and preserved for a period of three years thereafter for all laborers and mechanics working at the site of the work. Such records shall contain the name, address, and social security number of each such worker, his or her correct classification, hourly rates of wages paid (including rates of contributions or costs anticipated for bona fide fringe benefits or cash equivalents thereof of the types described in section 1(b)(2)(B) of the Davis-Bacon Act), daily and weekly number of hours worked, deductions made and actual wages paid. Whenever the Secretary of Labor has found under 29 CFR 5.5(a)(1)(iv) that the wages of any laborer or mechanic include the amount of any costs reasonably anticipated in providing benefits under a plan or program described in section 1(b)(2)(B) of the Davis-Bacon Act, the contractor shall maintain records which show that the commitment to provide such benefits is enforceable, that the plan or program is financially responsible, and that the plan or program has been communicated in writing to the laborers or mechanics affected, and records which show the costs anticipated or the actual cost incurred in providing such benefits. Contractors employing apprentices or trainees under approved programs shall maintain written evidence of the registration of apprenticeship programs and certification of trainee programs, the registration of the apprentices and trainees, and the ratios and wage rates prescribed in the applicable programs.
 - b. (1) The contractor shall submit weekly for each week in which any contract work is performed a copy of all payrolls to the contracting agency. The payrolls submitted shall set out accurately and completely all of the information required to be maintained under 29 CFR 5.5(a)(3)(i), except that full social security numbers and home addresses shall not be included on weekly transmittals. Instead the payrolls shall only need to include an individually identifying number for each employee (e.g. , the last four digits of the employee's social security number). The required weekly payroll information may be submitted in any form desired. Optional Form WH-347 is available for

this purpose from the Wage and Hour Division Web site at <http://www.dol.gov/esa/whd/forms/wh347instr.htm> or its successor site. The prime contractor is responsible for the submission of copies of payrolls by all subcontractors. Contractors and subcontractors shall maintain the full social security number and current address of each covered worker, and shall provide them upon request to the contracting agency for transmission to the State DOT, the FHWA or the Wage and Hour Division of the Department of Labor for purposes of an investigation or audit of compliance with prevailing wage requirements. It is not a violation of this section for a prime contractor to require a subcontractor to provide addresses and social security numbers to the prime contractor for its own records, without weekly submission to the contracting agency.

- (2) Each payroll submitted shall be accompanied by a "Statement of Compliance," signed by the contractor or subcontractor or his or her agent who pays or supervises the payment of the persons employed under the contract and shall certify the following:
 - (i) That the payroll for the payroll period contains the information required to be provided under §5.5 (a)(3)(ii) of Regulations, 29 CFR part 5, the appropriate information is being maintained under §5.5 (a)(3)(i) of Regulations, 29 CFR part 5, and that such information is correct and complete;
 - (ii) That each laborer or mechanic (including each helper, apprentice, and trainee) employed on the contract during the payroll period has been paid the full weekly wages earned, without rebate, either directly or indirectly, and that no deductions have been made either directly or indirectly from the full wages earned, other than permissible deductions as set forth in Regulations, 29 CFR part 3;
 - (iii) That each laborer or mechanic has been paid not less than the applicable wage rates and fringe benefits or cash equivalents for the classification of work performed, as specified in the applicable wage determination incorporated into the contract.
 - (3) The weekly submission of a properly executed certification set forth on the reverse side of Optional Form WH-347 shall satisfy the requirement for submission of the "Statement of Compliance" required by paragraph 3.b.(2) of this section.
 - (4) The falsification of any of the above certifications may subject the contractor or subcontractor to civil or criminal prosecution under section 1001 of title 18 and section 231 of title 31 of the United States Code.
- c. The contractor or subcontractor shall make the records required under paragraph 3.a. of this section available for inspection, copying, or transcription by authorized representatives of the contracting agency, the State DOT, the FHWA, or the Department of Labor, and shall permit such representatives to interview employees during working hours on the job. If the contractor or subcontractor fails to submit the required records or to make them available, the FHWA may, after written notice to the contractor, the contracting agency or the State DOT, take such action as may be necessary to cause the suspension of any further payment, advance, or guarantee of funds. Furthermore, failure to submit the required records upon request or to make such records available may be grounds for debarment action pursuant to 29 CFR 5.12.

4. Apprentices and trainees

- a. Apprentices (programs of the USDOL). Apprentices will be permitted to work at less than the predetermined rate for the work they performed when they are employed pursuant to and individually registered in a bona fide apprenticeship program registered with the U.S. Department of Labor, Employment and Training Administration, Office of Apprenticeship Training, Employer and Labor Services, or with a State Apprenticeship Agency recognized by the Office, or if a person is employed in his or her first 90 days of probationary employment as an apprentice in such an apprenticeship program, who is not individually registered in the program, but who has been certified by the Office of Apprenticeship Training, Employer and Labor Services or a State Apprenticeship Agency (where appropriate) to be eligible for probationary employment as an apprentice.

The allowable ratio of apprentices to journeymen on the job site in any craft classification shall not be greater than the ratio permitted to the contractor as to the entire work force under the registered program. Any worker listed on a payroll at an apprentice wage rate, who is not registered or otherwise employed as stated above, shall be paid not less than the applicable wage rate on the wage determination for the classification of work actually performed. In addition, any apprentice performing work on the job site in excess of the ratio permitted under the registered program shall be paid not less than the applicable wage rate on the wage determination for the work actually performed. Where a contractor is performing construction on a project in a locality other than that in which its program is registered, the ratios and wage rates (expressed in percentages of the journeyman's hourly rate) specified in the contractor's or subcontractor's registered program shall be observed.

Every apprentice must be paid at not less than the rate specified in the registered program for the apprentice's level of progress, expressed as a percentage of the journeymen hourly rate specified in the applicable wage determination. Apprentices shall be paid fringe benefits in accordance with the provisions of the apprenticeship program. If the apprenticeship program does not specify fringe benefits, apprentices must be paid the full amount of fringe benefits listed on the wage determination for the applicable classification. If the Administrator determines that a different practice prevails for the applicable apprentice classification, fringes shall be paid in accordance with that determination.

In the event the Office of Apprenticeship Training, Employer and Labor Services, or a State Apprenticeship Agency recognized by the Office, withdraws approval of an apprenticeship program, the contractor will no longer be permitted to utilize apprentices at less than the applicable predetermined rate for the work performed until an acceptable program is approved.

- b. Trainees (programs of the USDOL). Except as provided in 29 CFR 5.16, trainees will not be permitted to work at less than the predetermined rate for the work performed unless they are employed pursuant to and individually registered in a program which has received prior approval, evidenced by formal certification by the U.S. Department of Labor, Employment and Training Administration.

The ratio of trainees to journeymen on the job site shall not be greater than permitted under the plan approved by the Employment and Training Administration.

Every trainee must be paid at not less than the rate specified in the approved program for the trainee's level of progress, expressed as a percentage of the journeyman hourly rate specified in the applicable wage determination. Trainees shall be paid fringe benefits in accordance with the provisions of the trainee program. If the trainee program does not mention fringe benefits, trainees shall be paid the full amount of fringe benefits listed on the wage determination unless the Administrator of the Wage and Hour Division determines that there is an apprenticeship program associated with the corresponding journeyman wage rate on the wage determination which provides for less than full fringe benefits for apprentices. Any employee listed on the payroll at a trainee rate who is not registered and participating in a training plan approved by the Employment and Training Administration shall be paid not less than the applicable wage rate on the wage determination for the classification of work actually performed. In addition, any trainee performing work on the job site in excess of the ratio permitted under the registered program shall be paid not less than the applicable wage rate on the wage determination for the work actually performed.

In the event the Employment and Training Administration withdraws approval of a training program, the contractor will no longer be permitted to utilize trainees at less than the applicable predetermined rate for the work performed until an acceptable program is approved.

- c. Equal employment opportunity. The utilization of apprentices, trainees and journeymen under this part shall be in conformity with the equal employment opportunity requirements of Executive Order 11246, as amended, and 29 CFR part 30.
- d. Apprentices and Trainees (programs of the U.S. DOT). Apprentices and trainees working under apprenticeship and skill training programs which have been certified by the Secretary of Transportation as promoting EEO in connection with Federal-aid highway construction programs

are not subject to the requirements of paragraph 4 of this Section IV. The straight time hourly wage rates for apprentices and trainees under such programs will be established by the particular programs. The ratio of apprentices and trainees to journeymen shall not be greater than permitted by the terms of the particular program.

5. **Compliance with Copeland Act requirements.** The contractor shall comply with the requirements of 29 CFR part 3, which are incorporated by reference in this contract.
6. **Subcontracts.** The contractor or subcontractor shall insert Form FHWA-1273 in any subcontracts and also require the subcontractors to include Form FHWA-1273 in any lower tier subcontracts. The prime contractor shall be responsible for the compliance by any subcontractor or lower tier subcontractor with all the contract clauses in 29 CFR 5.5.
7. **Contract termination:** debarment. A breach of the contract clauses in 29 CFR 5.5 may be grounds for termination of the contract, and for debarment as a contractor and a subcontractor as provided in 29 CFR 5.12.
8. **Compliance with Davis-Bacon and Related Act requirements.** All rulings and interpretations of the Davis-Bacon and Related Acts contained in 29 CFR parts 1, 3, and 5 are herein incorporated by reference in this contract.
9. **Disputes concerning labor standards.** Disputes arising out of the labor standards provisions of this contract shall not be subject to the general disputes clause of this contract. Such disputes shall be resolved in accordance with the procedures of the Department of Labor set forth in 29 CFR parts 5, 6, and 7. Disputes within the meaning of this clause include disputes between the contractor (or any of its subcontractors) and the contracting agency, the U.S. Department of Labor, or the employees or their representatives.
10. **Certification of eligibility.**
 - a. By entering into this contract, the contractor certifies that neither it (nor he or she) nor any person or firm who has an interest in the contractor's firm is a person or firm ineligible to be awarded Government contracts by virtue of section 3(a) of the Davis-Bacon Act or 29 CFR 5.12(a)(1).
 - b. No part of this contract shall be subcontracted to any person or firm ineligible for award of a Government contract by virtue of section 3(a) of the Davis-Bacon Act or 29 CFR 5.12(a)(1).
 - c. The penalty for making false statements is prescribed in the U.S. Criminal Code, 18 U.S.C. 1001.

V. CONTRACT WORK HOURS AND SAFETY STANDARDS ACT

The following clauses apply to any Federal-aid construction contract in an amount in excess of \$100,000 and subject to the overtime provisions of the Contract Work Hours and Safety Standards Act. These clauses shall be inserted in addition to the clauses required by 29 CFR 5.5(a) or 29 CFR 4.6. As used in this paragraph, the terms laborers and mechanics include watchmen and guards.

1. **Overtime requirements.** No contractor or subcontractor contracting for any part of the contract work which may require or involve the employment of laborers or mechanics shall require or permit any such laborer or mechanic in any workweek in which he or she is employed on such work to work in excess of forty hours in such workweek unless such laborer or mechanic receives compensation at a rate not less than one and one-half times the basic rate of pay for all hours worked in excess of forty hours in such workweek.
2. **Violation; liability for unpaid wages; liquidated damages.** In the event of any violation of the clause set forth in paragraph (1.) of this section, the contractor and any subcontractor responsible therefor shall be liable for the unpaid wages. In addition, such contractor and subcontractor shall be liable to the United States (in the case of work done under contract for the District of Columbia or a territory, to such District or to such territory), for liquidated damages. Such liquidated damages shall be computed with respect to each individual laborer or mechanic, including watchmen and guards, employed in violation of the clause set forth in paragraph (1.) of this section, in the sum of \$10 for each calendar day on which such individual was required or permitted to work in excess of the standard workweek of forty hours without payment of the overtime wages required by the clause set forth in paragraph (1.) of this section.
3. **Withholding for unpaid wages and liquidated damages.** The FHWA or the contracting agency shall upon its own action or upon written request of an authorized representative of the Department of Labor withhold or cause to be withheld, from any moneys payable on account of work performed by the contractor or subcontractor under any such contract or any other Federal contract with the same prime contractor, or any other federally-assisted contract subject to the Contract Work Hours and Safety Standards Act, which is held by the same prime contractor, such sums as may be determined to be necessary to satisfy any liabilities of such contractor or subcontractor for unpaid wages and liquidated damages as provided in the clause set forth in paragraph (2.) of this section.
4. **Subcontracts.** The contractor or subcontractor shall insert in any subcontracts the clauses set forth in paragraph (1.) through (4.) of this section and also a clause requiring the subcontractors to include these clauses in any lower tier subcontracts. The prime contractor shall be responsible for compliance by any subcontractor or lower tier subcontractor with the clauses set forth in paragraphs (1.) through (4.) of this section.

VI. SUBLETTING OR ASSIGNING THE CONTRACT

This provision is applicable to all Federal-aid construction contracts on the National Highway System.

1. The contractor shall perform with its own organization contract work amounting to not less than 30 percent (or a greater percentage if specified elsewhere in the contract) of the total original contract price, excluding any specialty items designated by the contracting agency. Specialty items may be performed by subcontract and the amount of any such specialty items performed may be deducted from the total original contract price before computing the amount of work required to be performed by the contractor's own organization (23 CFR 635.116).
 - a. The term "perform work with its own organization" refers to workers employed or leased by the prime contractor, and equipment owned or rented by the prime contractor, with or without operators. Such term does not include employees or equipment of a subcontractor or lower tier subcontractor, agents of the prime contractor, or any other assignees. The term may include payments for the costs of hiring leased employees from an employee leasing firm meeting all relevant Federal and State regulatory requirements. Leased employees may only be included in this term if the prime contractor meets all of the following conditions:
 - (1) the prime contractor maintains control over the supervision of the day-to-day activities of the leased employees;
 - (2) the prime contractor remains responsible for the quality of the work of the leased employees;
 - (3) the prime contractor retains all power to accept or exclude individual employees from work on the project; and
 - (4) the prime contractor remains ultimately responsible for the payment of predetermined minimum wages, the submission of payrolls, statements of compliance and all other Federal regulatory requirements.
 - b. "Specialty Items" shall be construed to be limited to work that requires highly specialized knowledge, abilities, or equipment not ordinarily available in the type of contracting organizations qualified and expected to bid or propose on the contract as a whole and in general are to be limited to minor components of the overall contract.

2. The contract amount upon which the requirements set forth in paragraph (1) of Section VI is computed includes the cost of material and manufactured products which are to be purchased or produced by the contractor under the contract provisions.
3. The contractor shall furnish (a) a competent superintendent or supervisor who is employed by the firm, has full authority to direct performance of the work in accordance with the contract requirements, and is in charge of all construction operations (regardless of who performs the work) and (b) such other of its own organizational resources (supervision, management, and engineering services) as the contracting officer determines is necessary to assure the performance of the contract.
4. No portion of the contract shall be sublet, assigned or otherwise disposed of except with the written consent of the contracting officer, or authorized representative, and such consent when given shall not be construed to relieve the contractor of any responsibility for the fulfillment of the contract. Written consent will be given only after the contracting agency has assured that each subcontract is evidenced in writing and that it contains all pertinent provisions and requirements of the prime contract.
5. The 30% self-performance requirement of paragraph (1) is not applicable to design-build contracts; however, contracting agencies may establish their own self-performance requirements.

VII. SAFETY: ACCIDENT PREVENTION

This provision is applicable to all Federal-aid construction contracts and to all related subcontracts.

1. In the performance of this contract the contractor shall comply with all applicable Federal, State, and local laws governing safety, health, and sanitation (23 CFR 635). The contractor shall provide all safeguards, safety devices and protective equipment and take any other needed actions as it determines, or as the contracting officer may determine, to be reasonably necessary to protect the life and health of employees on the job and the safety of the public and to protect property in connection with the performance of the work covered by the contract.
2. It is a condition of this contract, and shall be made a condition of each subcontract, which the contractor enters into pursuant to this contract, that the contractor and any subcontractor shall not permit any employee, in performance of the contract, to work in surroundings or under conditions which are unsanitary, hazardous or dangerous to his/her health or safety, as determined under construction safety and health standards (29 CFR 1926) promulgated by the Secretary of Labor, in accordance with Section 107 of the Contract Work Hours and Safety Standards Act (40 U.S.C. 3704).
3. Pursuant to 29 CFR 1926.3, it is a condition of this contract that the Secretary of Labor or authorized representative thereof, shall have right of entry to any site of contract performance to inspect or investigate the matter of compliance with the construction safety and health standards and to carry out the duties of the Secretary under Section 107 of the Contract Work Hours and Safety Standards Act (40 U.S.C.3704).

VIII. FALSE STATEMENTS CONCERNING HIGHWAY PROJECTS

This provision is applicable to all Federal-aid construction contracts and to all related subcontracts.

In order to assure high quality and durable construction in conformity with approved plans and specifications and a high degree of reliability on statements and representations made by engineers, contractors, suppliers, and workers on Federal-aid highway projects, it is essential that all persons concerned with the project perform their functions as carefully, thoroughly, and honestly as possible. Willful falsification, distortion, or misrepresentation with respect to any facts related to the project is a violation of Federal law. To prevent any misunderstanding regarding the seriousness of these and similar acts, Form FHWA-1022 shall be posted on each Federal-aid highway project (23 CFR 635) in one or more places where it is readily available to all persons concerned with the project:

18 U.S.C. 1020 reads as follows:

"Whoever, being an officer, agent, or employee of the United States, or of any State or Territory, or whoever, whether a person, association, firm, or corporation, knowingly makes any false statement, false representation, or false report as to the character, quality, quantity, or cost of the material used or to be used, or the quantity or quality of the work performed or to be performed, or the cost thereof in connection with the submission of plans, maps, specifications, contracts, or costs of construction on any highway or related project submitted for approval to the Secretary of Transportation; or

Whoever knowingly makes any false statement, false representation, false report or false claim with respect to the character, quality, quantity, or cost of any work performed or to be performed, or materials furnished or to be furnished, in connection with the construction of any highway or related project approved by the Secretary of Transportation; or

Whoever knowingly makes any false statement or false representation as to material fact in any statement, certificate, or report submitted pursuant to provisions of the Federal-aid Roads Act approved July 1, 1916, (39 Stat. 355), as amended and supplemented;

Shall be fined under this title or imprisoned not more than 5 years or both."

IX. IMPLEMENTATION OF CLEAN AIR ACT AND FEDERAL WATER POLLUTION CONTROL ACT

This provision is applicable to all Federal-aid construction contracts and to all related subcontracts.

By submission of this bid/proposal or the execution of this contract, or subcontract, as appropriate, the bidder, proposer, Federal-aid construction contractor, or subcontractor, as appropriate, will be deemed to have stipulated as follows:

1. That any person who is or will be utilized in the performance of this contract is not prohibited from receiving an award due to a violation of Section 508 of the Clean Water Act or Section 306 of the Clean Air Act.
2. That the contractor agrees to include or cause to be included the requirements of paragraph (1) of this Section X in every subcontract, and further agrees to take such action as the contracting agency may direct as a means of enforcing such requirements.

X. CERTIFICATION REGARDING DEBARMENT, SUSPENSION, INELIGIBILITY AND VOLUNTARY EXCLUSION

This provision is applicable to all Federal-aid construction contracts, design-build contracts, subcontracts, lower-tier subcontracts, purchase orders, lease agreements, consultant contracts or any other covered transaction requiring FHWA approval or that is estimated to cost \$25,000 or more – as defined in 2 CFR Parts 180 and 1200.

1. Instructions for Certification – First Tier Participants:

- a. By signing and submitting this proposal, the prospective first tier participant is providing the certification set out below.
- b. The inability of a person to provide the certification set out below will not necessarily result in denial of participation in this covered transaction. The prospective first tier participant shall submit an explanation of why it cannot provide the certification set out below. The certification or explanation will be considered in connection with the department or agency's determination whether to enter into this transaction. However,

failure of the prospective first tier participant to furnish a certification or an explanation shall disqualify such a person from participation in this transaction.

- c. The certification in this clause is a material representation of fact upon which reliance was placed when the contracting agency determined to enter into this transaction. If it is later determined that the prospective participant knowingly rendered an erroneous certification, in addition to other remedies available to the Federal Government, the contracting agency may terminate this transaction for cause of default.
- d. The prospective first tier participant shall provide immediate written notice to the contracting agency to whom this proposal is submitted if any time the prospective first tier participant learns that its certification was erroneous when submitted or has become erroneous by reason of changed circumstances.
- e. The terms "covered transaction," "debarred," "suspended," "ineligible," "participant," "person," "principal," and "voluntarily excluded," as used in this clause, are defined in 2 CFR Parts 180 and 1200. "First Tier Covered Transactions" refers to any covered transaction between a grantee or subgrantee of Federal funds and a participant (such as the prime or general contract). "Lower Tier Covered Transactions" refers to any covered transaction under a First Tier Covered Transaction (such as subcontracts). "First Tier Participant" refers to the participant who has entered into a covered transaction with a grantee or subgrantee of Federal funds (such as the prime or general contractor). "Lower Tier Participant" refers any participant who has entered into a covered transaction with a First Tier Participant or other Lower Tier Participants (such as subcontractors and suppliers).
- f. The prospective first tier participant agrees by submitting this proposal that, should the proposed covered transaction be entered into, it shall not knowingly enter into any lower tier covered transaction with a person who is debarred, suspended, declared ineligible, or voluntarily excluded from participation in this covered transaction, unless authorized by the department or agency entering into this transaction.
- g. The prospective first tier participant further agrees by submitting this proposal that it will include the clause titled "Certification Regarding Debarment, Suspension, Ineligibility and Voluntary Exclusion-Lower Tier Covered Transactions," provided by the department or contracting agency, entering into this covered transaction, without modification, in all lower tier covered transactions and in all solicitations for lower tier covered transactions exceeding the \$25,000 threshold.
- h. A participant in a covered transaction may rely upon a certification of a prospective participant in a lower tier covered transaction that is not debarred, suspended, ineligible, or voluntarily excluded from the covered transaction, unless it knows that the certification is erroneous. A participant is responsible for ensuring that its principals are not suspended, debarred, or otherwise ineligible to participate in covered transactions. To verify the eligibility of its principals, as well as the eligibility of any lower tier prospective participants, each participant may, but is not required to, check the Excluded Parties List System website (<https://www.epls.gov/>), which is compiled by the General Services Administration.
- i. Nothing contained in the foregoing shall be construed to require the establishment of a system of records in order to render in good faith the certification required by this clause. The knowledge and information of the prospective participant is not required to exceed that which is normally possessed by a prudent person in the ordinary course of business dealings.
- j. Except for transactions authorized under paragraph (f) of these instructions, if a participant in a covered transaction knowingly enters into a lower tier covered transaction with a person who is suspended, debarred, ineligible, or voluntarily excluded from participation in this transaction, in addition to other remedies available to the Federal Government, the department or agency may terminate this transaction for cause or default.

* * * * *

2. **Certification Regarding Debarment, Suspension, Ineligibility and Voluntary Exclusion – First Tier Participants:**

- a. The prospective first tier participant certifies to the best of its knowledge and belief, that it and its principals:
 - (1) Are not presently debarred, suspended, proposed for debarment, declared ineligible, or voluntarily excluded from participating in covered transactions by any Federal department or agency;
 - (2) Have not within a three-year period preceding this proposal been convicted of or had a civil judgment rendered against them for commission of fraud or a criminal offense in connection with obtaining, attempting to obtain, or performing a public (Federal, State or local) transaction or contract under a public transaction; violation of Federal or State antitrust statutes or commission of embezzlement, theft, forgery, bribery, falsification or destruction of records, making false statements, or receiving stolen property;
 - (3) Are not presently indicted for or otherwise criminally or civilly charged by a governmental entity (Federal, State or local) with commission of any of the offenses enumerated in paragraph (a)(2) of this certification; and
 - (4) Have not within a three-year period preceding this application/proposal had one or more public transactions (Federal, State or local) terminated for cause or default.
- b. Where the prospective participant is unable to certify to any of the statements in this certification, such prospective participant shall attach an explanation to this proposal.

2. **Instructions for Certification - Lower Tier Participants:**

(Applicable to all subcontracts, purchase orders and other lower tier transactions requiring prior FHWA approval or estimated to cost \$25,000 or more - 2 CFR Parts 180 and 1200)

- a. By signing and submitting this proposal, the prospective lower tier is providing the certification set out below.
- b. The certification in this clause is a material representation of fact upon which reliance was placed when this transaction was entered into. If it is later determined that the prospective lower tier participant knowingly rendered an erroneous certification, in addition to other remedies available to the Federal Government, the department, or agency with which this transaction originated may pursue available remedies, including suspension and/or debarment.
- c. The prospective lower tier participant shall provide immediate written notice to the person to which this proposal is submitted if at any time the prospective lower tier participant learns that its certification was erroneous by reason of changed circumstances.
- d. The terms "covered transaction," "debarred," "suspended," "ineligible," "participant," "person," "principal," and "voluntarily excluded," as used in this clause, are defined in 2 CFR Parts 180 and 1200. You may contact the person to which this proposal is submitted for assistance in obtaining a copy of those regulations. "First Tier Covered Transactions" refers to any covered transaction between a grantee or subgrantee of Federal funds and a participant (such as the prime or general contract). "Lower Tier Covered Transactions" refers to any covered transaction under a First Tier Covered Transaction (such as subcontracts). "First Tier Participant" refers to the participant who has entered into a covered transaction with a grantee or subgrantee of Federal funds (such as the prime or general contractor). "Lower Tier Participant" refers any participant who has entered into a covered transaction with a First Tier Participant or other Lower Tier Participants (such as subcontractors and suppliers).

- e. The prospective lower tier participant agrees by submitting this proposal that, should the proposed covered transaction be entered into, it shall not knowingly enter into any lower tier covered transaction with a person who is debarred, suspended, declared ineligible, or voluntarily excluded from participation in this covered transaction, unless authorized by the department or agency with which this transaction originated.
- f. The prospective lower tier participant further agrees by submitting this proposal that it will include this clause titled "Certification Regarding Debarment, Suspension, Ineligibility and Voluntary Exclusion-Lower Tier Covered Transaction," without modification, in all lower tier covered transactions and in all solicitations for lower tier covered transactions exceeding the \$25,000 threshold.
- g. A participant in a covered transaction may rely upon a certification of a prospective participant in a lower tier covered transaction that is not debarred, suspended, ineligible, or voluntarily excluded from the covered transaction, unless it knows that the certification is erroneous. A participant is responsible for ensuring that its principals are not suspended, debarred, or otherwise ineligible to participate in covered transactions. To verify the eligibility of its principals, as well as the eligibility of any lower tier prospective participants, each participant may, but is not required to, check the Excluded Parties List System website (<https://www.epls.gov/>), which is compiled by the General Services Administration.
- h. Nothing contained in the foregoing shall be construed to require establishment of a system of records in order to render in good faith the certification required by this clause. The knowledge and information of participant is not required to exceed that which is normally possessed by a prudent person in the ordinary course of business dealings.
- i. Except for transactions authorized under paragraph e of these instructions, if a participant in a covered transaction knowingly enters into a lower tier covered transaction with a person who is suspended, debarred, ineligible, or voluntarily excluded from participation in this transaction, in addition to other remedies available to the Federal Government, the department or agency with which this transaction originated may pursue available remedies, including suspension and/or debarment.

* * * * *

Certification Regarding Debarment, Suspension, Ineligibility and Voluntary Exclusion--Lower Tier Participants:

1. The prospective lower tier participant certifies, by submission of this proposal, that neither it nor its principals is presently debarred, suspended, proposed for debarment, declared ineligible, or voluntarily excluded from participating in covered transactions by any Federal department or agency.
2. Where the prospective lower tier participant is unable to certify to any of the statements in this certification, such prospective participant shall attach an explanation to this proposal.

* * * * *

XI. CERTIFICATION REGARDING USE OF CONTRACT FUNDS FOR LOBBYING

This provision is applicable to all Federal-aid construction contracts and to all related subcontracts which exceed \$100,000 (49 CFR 20).

1. The prospective participant certifies, by signing and submitting this bid or proposal, to the best of his or her knowledge and belief, that:
 - a. No Federal appropriated funds have been paid or will be paid, by or on behalf of the undersigned, to any person for influencing or attempting to influence an officer or employee of any Federal agency, a Member of Congress, an officer or employee of Congress, or an employee of a Member of Congress in connection with the awarding of any Federal contract, the making of any Federal grant, the making of any Federal loan, the entering into of any cooperative agreement, and the extension, continuation, renewal, amendment, or modification of any Federal contract, grant, loan, or cooperative agreement.
 - b. If any funds other than Federal appropriated funds have been paid or will be paid to any person for influencing or attempting to influence an officer or employee of any Federal agency, a Member of Congress, an officer or employee of Congress, or an employee of a Member of Congress in connection with this Federal contract, grant, loan, or cooperative agreement, the undersigned shall complete and submit Standard Form-LLL, "Disclosure Form to Report Lobbying," in accordance with its instructions.
2. This certification is a material representation of fact upon which reliance was placed when this transaction was made or entered into. Submission of this certification is a prerequisite for making or entering into this transaction imposed by 31 U.S.C. 1352. Any person who fails to file the required certification shall be subject to a civil penalty of not less than \$10,000 and not more than \$100,000 for each such failure.
3. The prospective participant also agrees by submitting its bid or proposal that the participant shall require that the language of this certification be included in all lower tier subcontracts, which exceed \$100,000 and that all such recipients shall certify and disclose accordingly.

STANDARD SPECIAL PROVISION**ON-THE-JOB TRAINING**

(10-16-07) (Rev. 4-21-15)

Z-10

Description

The North Carolina Department of Transportation will administer a custom version of the Federal On-the-Job Training (OJT) Program, commonly referred to as the Alternate OJT Program. All contractors (existing and newcomers) will be automatically placed in the Alternate Program. Standard OJT requirements typically associated with individual projects will no longer be applied at the project level. Instead, these requirements will be applicable on an annual basis for each contractor administered by the OJT Program Manager.

On the Job Training shall meet the requirements of 23 CFR 230.107 (b), 23 USC – Section 140, this provision and the On-the-Job Training Program Manual.

The Alternate OJT Program will allow a contractor to train employees on Federal, State and privately funded projects located in North Carolina. However, priority shall be given to training employees on NCDOT Federal-Aid funded projects.

Minorities and Women

Developing, training and upgrading of minorities and women toward journeyman level status is a primary objective of this special training provision. Accordingly, the Contractor shall make every effort to enroll minority and women as trainees to the extent that such persons are available within a reasonable area of recruitment. This training commitment is not intended, and shall not be used, to discriminate against any applicant for training, whether a member of a minority group or not.

Assigning Training Goals

The Department, through the OJT Program Manager, will assign training goals for a calendar year based on the contractors' past three years' activity and the contractors' anticipated upcoming year's activity with the Department. At the beginning of each year, all contractors eligible will be contacted by the Department to determine the number of trainees that will be assigned for the upcoming calendar year. At that time the Contractor shall enter into an agreement with the Department to provide a self-imposed on-the-job training program for the calendar year. This agreement will include a specific number of annual training goals agreed to by both parties. The number of training assignments may range from 1 to 15 per contractor per calendar year. The Contractor shall sign an agreement to fulfill their annual goal for the year.\

Training Classifications

The Contractor shall provide on-the-job training aimed at developing full journeyman level workers in the construction craft/operator positions. Preference shall be given to providing training in the following skilled work classifications:

| | |
|---------------------|----------------------------------|
| Equipment Operators | Office Engineers |
| Truck Drivers | Estimators |
| Carpenters | Iron / Reinforcing Steel Workers |
| Concrete Finishers | Mechanics |
| Pipe Layers | Welders |

The Department has established common training classifications and their respective training requirements that may be used by the contractors. However, the classifications established are not all-inclusive. Where the training is oriented toward construction applications, training will be allowed in lower-level management positions such as office engineers and estimators. Contractors shall submit new classifications for specific job functions that their employees are performing. The Department will review and recommend for acceptance to FHWA the new classifications proposed by contractors, if applicable. New classifications shall meet the following requirements:

Proposed training classifications are reasonable and realistic based on the job skill classification needs, and

The number of training hours specified in the training classification is consistent with common practices and provides enough time for the trainee to obtain journeyman level status.

The Contractor may allow trainees to be trained by a subcontractor provided that the Contractor retains primary responsibility for meeting the training and this provision is made applicable to the subcontract. However, only the Contractor will receive credit towards the annual goal for the trainee.

Where feasible, 25 percent of apprentices or trainees in each occupation shall be in their first year of apprenticeship or training. The number of trainees shall be distributed among the work classifications on the basis of the contractor's needs and the availability of journeymen in the various classifications within a reasonable area of recruitment.

No employee shall be employed as a trainee in any classification in which they have successfully completed a training course leading to journeyman level status or in which they have been employed as a journeyman.

Records and Reports

The Contractor shall maintain enrollment, monthly and completion reports documenting company compliance under these contract documents. These documents and any other information as requested shall be submitted to the OJT Program Manager.

Upon completion and graduation of the program, the Contractor shall provide each trainee with a certification Certificate showing the type and length of training satisfactorily completed.

Trainee Interviews

All trainees enrolled in the program will receive an initial and Trainee/Post graduate interview conducted by the OJT program staff.

Trainee Wages

Contractors shall compensate trainees on a graduating pay scale based upon a percentage of the prevailing minimum journeyman wages (Davis-Bacon Act). Minimum pay shall be as follows:

| | |
|------------|---------------------------------------------------------------------|
| 60 percent | of the journeyman wage for the first half of the training period |
| 75 percent | of the journeyman wage for the third quarter of the training period |
| 90 percent | of the journeyman wage for the last quarter of the training period |

In no instance shall a trainee be paid less than the local minimum wage. The Contractor shall adhere to the minimum hourly wage rate that will satisfy both the NC Department of Labor (NCDOL) and the Department.

Achieving or Failing to Meet Training Goals

The Contractor will be credited for each trainee employed by him on the contract work who is currently enrolled or becomes enrolled in an approved program and who receives training for at least 50 percent of the specific program requirement. Trainees will be allowed to be transferred between projects if required by the Contractor's scheduled workload to meet training goals.

If a contractor fails to attain their training assignments for the calendar year, they may be taken off the NCDOT's Bidders List.

Measurement and Payment

No compensation will be made for providing required training in accordance with these contract documents.

STANDARD SPECIAL PROVISION

NAME CHANGE FOR NCDENR

(1-19-16)

Z-11

Description

Wherever in the 2012 Standard Specifications, Project Special Provisions, Standard Special Provisions, Permits or Plans that reference is made to “NCDENR” or “North Carolina Department of Environment and Natural Resources”, replace with “NCDEQ” or “North Carolina Department of Environmental Quality” respectively, as the case may be.

STANDARD SPECIAL PROVISION
MINIMUM WAGES
GENERAL DECISION NC170101 01/06/2017 NC101

Z-101

Date: January 6, 2017

General Decision Number: NC170101 01/06/2017 NC101

Superseded General Decision Numbers: NC20160101

State: North Carolina

Construction Type: HIGHWAY

COUNTIES:

| | | |
|----------|-------------|------------|
| Alamance | Forsyth | Randolph |
| Anson | Gaston | Rockingham |
| Cabarrus | Guilford | Stokes |
| Chatham | Mecklenburg | Union |
| Davie | Orange | Yadkin |
| Durham | Person | |

HIGHWAY CONSTRUCTION PROJECTS (excluding tunnels, building structures in rest area projects & railroad construction; bascule, suspension & spandrel arch bridges designed for commercial navigation, bridges involving marine construction; and other major bridges).

Note: Under Executive Order (EO) 13658, an hourly minimum wage of \$10.20 for calendar year 2017 applies to all contracts subject to the Davis-Bacon Act for which the contract is awarded (and any solicitation was issued) on or after January 1, 2015. If this contract is covered by the EO, the contractor must pay all workers in any classification listed on this wage determination at least \$10.20 per hour (or the applicable wage rate listed on this wage determination, if it is higher) for all hours spent performing on the contract for calendar year 2017. The EO minimum wage rate will be adjusted annually. Additional information on contractor requirements and worker protections under the EO is available at www.dol.gov/whd/govcontracts.

Modification Number
0

Publication Date
01/06/2017

SUNC2014-003 11/14/2014

| | Rates | Fringes |
|--------------------------------|-------|---------|
| BLASTER | 18.64 | |
| CARPENTER | 13.68 | .05 |
| CEMENT MASON/CONCRETE FINISHER | 13.93 | |
| ELECTRICIAN | | |
| Electrician | 18.79 | 2.72 |
| Telecommunications Technician | 15.19 | 1.25 |
| IRONWORKER | 13.30 | |
| LABORER | | |

| | Rates | Fringes |
|-------------------------------------------|-------|---------|
| Asphalt Raker and Spreader | 12.78 | |
| Asphalt Screed/Jackman | 14.50 | |
| Carpenter Tender | 12.51 | .27 |
| Cement Mason/Concrete Finisher Tender | 11.04 | |
| Common or General | 10.40 | .01 |
| Guardrail/Fence Installer | 13.22 | |
| Pipelayer | 12.43 | |
| Traffic Signal/Lighting Installer | 15.65 | .24 |
| PAINTER | | |
| Bridge | 23.77 | |
| POWER EQUIPMENT OPERATORS | | |
| Asphalt Broom Tractor | 10.00 | |
| Bulldozer Fine | 16.13 | |
| Bulldozer Rough | 14.36 | |
| Concrete Grinder/Groover | 17.92 | |
| Crane Boom Trucks | 18.19 | |
| Crane Other | 19.83 | |
| Crane Rough/All-Terrain | 19.10 | |
| Drill Operator Rock | 14.28 | |
| Drill Operator Structure | 20.89 | |
| Excavator Fine | 16.95 | |
| Excavator Rough | 13.63 | |
| Grader/Blade Fine | 19.84 | |
| Grader/Blade Rough | 15.47 | |
| Loader 2 Cubic Yards or Less | 13.31 | |
| Loader Greater Than 2 Cubic Yards | 16.19 | |
| Material Transfer Vehicle (Shuttle Buggy) | 15.44 | |
| Mechanic | 17.51 | |
| Milling Machine | 15.22 | |
| Off-Road Hauler/Water Tanker | 11.83 | |
| Oiler/Greaser | 14.16 | |
| Pavement Marking Equipment | 12.05 | |
| Paver Asphalt | 15.97 | |
| Paver Concrete | 18.20 | |
| Roller Asphalt Breakdown | 12.79 | |
| Roller Asphalt Finish | 13.76 | |
| Roller Other | 12.08 | |
| Scraper Finish | 12.65 | |
| Scraper Rough | 11.50 | |
| Slip Form Machine | 19.60 | |
| Tack Truck/Distributor Operator | 14.82 | |
| TRUCK DRIVER | | |
| GVWR of 26,000 Lbs or Less | 11.45 | |
| GVWR of 26,000 Lbs or Greater | 13.57 | .03 |

Welders – Receive rate prescribed for craft performing operation to which welding is incidental.

Note: Executive Order (EO) 13706, Establishing Paid Sick Leave for Federal Contractors applies to all contracts subject to the Davis-Bacon Act for which the contract is awarded (and any solicitation was issued) on or after January 1, 2017. If this contract is covered by the EO, the

contractor must provide employees with 1 hour of paid sick leave for every 30 hours they work, up to 56 hours of paid sick leave each year. Employees must be permitted to use paid sick leave for their own illness, injury or other health-related needs, including preventive care; to assist a family member (or person who is like family to the employee) who is ill, injured, or has other health-related needs, including preventive care; or for reasons resulting from, or to assist a family member (or person who is like family to the employee) who is a victim of, domestic violence, sexual assault, or stalking. Additional information on contractor requirements and worker protections under the EO is available at www.dol.gov/whd/govcontracts.

Unlisted classifications needed for work not included within the scope of the classifications listed may be added after award only as provided in the labor standards contract clauses (29 CFR 5.5(a)(1)(ii)).

The body of each wage determination lists the classification and wage rates that have been found to be prevailing for the cited type(s) of construction in the area covered by the wage determination. The classifications are listed in alphabetical order of "identifiers" that indicate whether the particular rate is a union rate (current union negotiated rate for local), a survey rate (weighted average rate) or a union average rate (weighted union average rate).

Union Rate Identifiers

A four letter classification abbreviation identifier enclosed in dotted lines beginning with characters other than "SU" or "UAVG" denotes that the union classification and rate were prevailing for that classification in the survey. Example: PLUM0198-005 07/01/2014. PLUM is an abbreviation identifier of the union which prevailed in the survey for this classification, which in this example would be Plumbers. 0198 indicates the local union number or district council number where applicable, i.e., Plumbers Local 0198. The next number, 005 in the example, is an internal number used in processing the wage determination. 07/01/2014 is the effective date of the most current negotiated rate, which in this example is July 1, 2014.

Union prevailing wage rates are updated to reflect all rate changes in the collective bargaining agreement (CBA) governing this classification and rate.

Survey Rate Identifiers

Classifications listed under the "SU" identifier indicate that no one rate prevailed for this classification in the survey and the published rate is derived by computing a weighted average rate based on all the rates reported in the survey for that classification. As this weighted average rate includes all rates reported in the survey, it may include both union and non-union rates. Example: SULA2012-007 5/13/2014. SU indicates the rates are survey rates based on a weighted average calculation of rates and are not majority rates. LA indicates the State of Louisiana. 2012 is the year of survey on which these classifications and rates are based. The next number, 007 in the example, is an internal number used in producing the wage determination. 5/13/2014 indicates the survey completion date for the classifications and rates under that identifier.

Survey wage rates are not updated and remain in effect until a new survey is conducted.

Union Average Rate Identifiers

Classification(s) listed under the UAVG identifier indicate that no single majority rate prevailed for those classifications; however, 100% of the data reported for the classifications was union data. EXAMPLE: UAVG-OH-0010 08/29/2014. UAVG indicates that the rate is a weighted union average rate. OH indicates the state. The next number, 0010 in the example, is an internal number used in producing the wage determination. 08/29/2014 indicates the survey completion date for the classifications and rates under that identifier.

A UAVG rate will be updated once a year, usually in January of each year, to reflect a weighted average of the current negotiated/CBA rate of the union locals from which the rate is based.

WAGE DETERMINATION APPEALS PROCESS

1.) Has there been an initial decision in the matter? This can be:

- * an existing published wage determination
- * a survey underlying a wage determination
- * a Wage and Hour Division letter setting forth a position on a wage determination matter
- * a conformance (additional classification and rate) ruling

On survey related matters, initial contact, including requests for summaries of surveys, should be with the Wage and Hour Regional Office for the area in which the survey was conducted because those Regional Offices have responsibility for the Davis-Bacon survey program. If the response from this initial contact is not satisfactory, then the process described in 2.) and 3.) should be followed.

With regard to any other matter not yet ripe for the formal process described here, initial contact should be with the Branch of Construction Wage Determinations. Write to:

Branch of Construction Wage Determinations
Wage and Hour Division
U. S. Department of Labor
200 Constitution Avenue, N.W.
Washington, D.C. 20210

2.) If the answer to the question in 1.) is yes, then an interested party (those affected by the action) can request review and reconsideration from the Wage and Hour Administrator (See 29 CFR Part 1.8 and 29 CFR Part 7). Write to:

Wage and Hour Administrator
U.S. Department of Labor
200 Constitution Avenue, N.W.
Washington, D.C. 20210

The request should be accompanied by a full statement of the interested party's position and by any information (wage payment data, project description, area practice material, etc.) that the requestor considers relevant to the issue.

3.) If the decision of the Administrator is not favorable, an interested party may appeal directly to the Administrative Review Board (formerly the Wage Appeals Board). Write to:

Administrative Review Board
U.S. Department of Labor
200 Constitution Avenue, N.W.
Washington, D.C. 20210

- 4.) All decisions by the Administrative Review Board are final.

END OF GENERAL DECISION

W-5520

GT-1

Union County

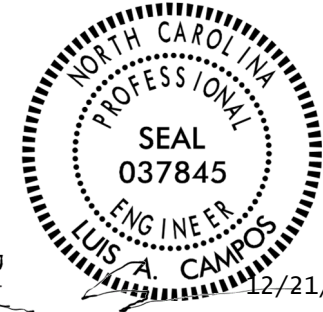

TEMPORARY SHORING:

Description

Temporary shoring includes cantilever, braced and anchored shoring and temporary mechanically stabilized earth (MSE) walls. Temporary shoring does not include trench boxes. At the Contractor's option, use any type of temporary shoring unless noted otherwise in the plans or as directed. Design and construct temporary shoring based on actual elevations and shoring dimensions in accordance with the contract and accepted submittals. Construct temporary shoring at locations shown in the plans and as directed. Temporary shoring is required to maintain traffic when a 2:1 (H:V) slope from the top of an embankment or bottom of an excavation will intersect the existing ground line less than 5 ft from the edge of pavement of an open travelway. This provision does not apply to pipe, inlet or utility installation unless noted otherwise in the plans.

Positive protection includes concrete barrier and temporary guardrail. Provide positive protection for temporary shoring at locations shown in the plans and as directed. Positive protection is required if temporary shoring is located in the clear zone in accordance with the *AASHTO Roadside Design Guide*.

(A) Cantilever and Braced Shoring

Cantilever shoring consists of steel sheet piles or H-piles with timber lagging. Braced shoring consists of sheet piles or H-piles with timber lagging and bracing such as beams, plates, walers, struts, rakers, etc. Define "piles" as sheet piles or H-piles.

(B) Anchored Shoring

Anchored shoring consists of sheet piles with walers or H-piles with timber lagging anchored with ground or helical anchors. Driven anchors may be accepted at the discretion of the Engineer. A ground anchor consists of a grouted steel bar or multi-strand tendon with an anchorage. A helical anchor consists of a lead section with a central steel shaft and at least one helix steel plate followed by extensions with only central shafts (no helixes) and an anchorage. Anchorages consist of steel bearing plates with washers and hex nuts for bars or steel wedge plates and wedges for strands. Use a prequalified Anchored Wall Contractor to install ground anchors. Define "anchors" as ground, helical or driven anchors.

(C) Temporary MSE Walls

Temporary MSE walls include temporary geosynthetic and wire walls. Define "temporary wall" as a temporary MSE wall. Define "reinforcement" as geotextile, geogrid, welded wire grid or metallic strip reinforcement.

W-5520

GT-2

Union County

Temporary geosynthetic walls consist of geotextile or geogrid reinforcement wrapped behind welded wire facing. Define “temporary geotextile wall” as a temporary geosynthetic wall with geotextile reinforcement and “temporary geogrid wall” as a temporary geosynthetic wall with geogrid reinforcement.

Temporary wire walls consist of welded wire grid or metallic strip reinforcement connected to welded wire facing. Define “Wire Wall Vendor” as the vendor supplying the temporary wire wall.

(D) Embedment

Define “embedment” for cantilever, braced and anchored shoring as the pile depth below the grade in front of shoring. Define “embedment” for temporary walls as the wall height below the grade in front of walls.

(E) Positive Protection

Define “unanchored or anchored portable concrete barrier” as portable concrete barrier (PCB) that meets Standard Drawing No. 1170.01 of the *2012 Roadway Standard Drawings*. Define “concrete barrier” as unanchored or anchored PCB or an approved equal. Define “temporary guardrail” as temporary steel beam guardrail that meets Standard Drawing No. 862.02 of the *2012 Roadway Standard Drawings*.

Materials

Refer to the *2012 Standard Specifications*.

| Item | Section |
|--------------------------------|----------------|
| Anchor Pins | 1056-2 |
| Concrete Barrier Materials | 1170-2 |
| Flowable Fill, Excavatable | 1000-6 |
| Geotextiles | 1056 |
| Grout | 1003 |
| Portland Cement Concrete | 1000 |
| Select Material | 1016 |
| Steel Beam Guardrail Materials | 862-2 |
| Steel Plates | 1072-2 |
| Steel Sheet Piles and H-Piles | 1084 |
| Untreated Timber | 1082-2 |
| Welded Wire Reinforcement | 1070-3 |
| Wire Staples | 1060-8(D) |

Provide Type 6 material certifications for shoring materials in accordance with Article 106-3 of the *2012 Standard Specifications*. Use Class IV select material (standard size No. ABC) for temporary guardrail. Use neat cement grout for Type 2 grout for ground anchors. Use Class A

W-5520

GT-3

Union County

concrete that meets Article 450-2 of the *2012 Standard Specifications* or Type 1 grout for drilled-in piles. Provide untreated timber with a thickness of at least 3" and a bending stress of at least 1,000 psi for timber lagging. Provide steel bracing that meets ASTM A36.

(A) Shoring Backfill

Use Class II, Type 1, Class III, Class V or Class VI select material or material that meets AASHTO M 145 for soil classification A-2-4 with a maximum PI of 6 for shoring backfill except do not use A-2-4 soil for backfill around culverts.

(B) Anchors

Store anchor materials on blocking a minimum of 12" above the ground and protect it at all times from damage; and when placing in the work make sure it is free from dirt, dust, loose mill scale, loose rust, paint, oil or other foreign materials. Load, transport, unload and store anchor materials so materials are kept clean and free of damage. Bent, damaged or defective materials will be rejected.

(1) Ground Anchors

Use high-strength deformed steel bars that meet AASHTO M 275 or seven-wire strands that meet ASTM A886 or Article 1070-5 of the *2012 Standard Specifications*. Splice bars in accordance with Article 1070-9 of the *2012 Standard Specifications*. Do not splice strands. Use bondbreakers, spacers and centralizers that meet Article 6.3.5 of the *AASHTO LRFD Bridge Construction Specifications*.

(2) Helical Anchors

Use helical anchors with an ICC Evaluation Service, Inc. (ICC-ES) report. Helical anchors without an ICC-ES report may be approved at the discretion of the Engineer. Provide couplers, thread bar adapters and bolts recommended by the Anchor Manufacturer to connect helical anchors together and to piles.

(3) Anchorages

Provide steel plates for bearing plates and steel washers, hex nuts, wedge plates and wedges recommended by the Anchor Manufacturer.

(C) Temporary Walls

(1) Welded Wire Facing

Use welded wire reinforcement for welded wire facing, struts and wires. For temporary wire walls, provide welded wire facing supplied by the Wire Wall Vendor or a manufacturer approved or licensed by the vendor. For temporary wire walls with separate reinforcement and facing components, provide connectors (e.g.,

W-5520

GT-4

Union County

bars, clamps, plates, etc.) and fasteners (e.g., bolts, nuts, washers, etc.) required by the Wire Wall Vendor.

(2) Geotextiles

Provide Type 2 geotextile for separation and retention geotextiles. Provide Type 5 geotextile for geotextile reinforcement with ultimate tensile strengths in accordance with the accepted submittals.

(3) Geogrid Reinforcement

Handle and store geogrids in accordance with Article 1056-2 of the *2012 Standard Specifications*. Define “machine direction” (MD) and “cross-machine direction” (CD) for geogrids in accordance with ASTM D4439.

Use geogrids with a roll width of at least 4 ft and an “approved” or “approved for provisional use” status code. The list of approved geogrids is available from: connect.ncdot.gov/resources/Materials/Pages/SoilsLaboratory.aspx

Provide geogrids for geogrid reinforcement with design strengths in accordance with the accepted submittals. Geogrids are typically approved for ultimate tensile strengths in the MD and CD or short-term design strengths for a 3-year design life in the MD based on material type. Define material type from the website above for shoring backfill as follows:

| Material Type | Shoring Backfill |
|----------------------|-----------------------------------------------|
| Borrow | A-2-4 Soil |
| Fine Aggregate | Class II, Type 1 or Class III Select Material |
| Coarse Aggregate | Class V or VI Select Material |

(4) Welded Wire Grid and Metallic Strip Reinforcement

Provide welded wire grid and metallic strip reinforcement supplied by the Wire Wall Vendor or a manufacturer approved or licensed by the vendor. Use welded wire grid reinforcement (“mesh”, “mats” and “ladders”) that meet Article 1070-3 of the *2012 Standard Specifications* and metallic strip reinforcement (“straps”) that meet ASTM A572 or A1011.

Preconstruction Requirements

(A) Concrete Barrier

Define “clear distance” behind concrete barrier as the horizontal distance between the barrier and edge of pavement. The minimum required clear distance for concrete barrier is shown in the plans. At the Contractor’s option or if the minimum required clear distance is not available, set concrete barrier next to and up against traffic side of temporary shoring

W-5520

GT-5

Union County

except for barrier above temporary walls. Concrete barrier with the minimum required clear distance is required above temporary walls.

(B) Temporary Guardrail

Define “clear distance” behind temporary guardrail as the horizontal distance between guardrail posts and temporary shoring. At the Contractor’s option or if clear distance for cantilever, braced and anchored shoring is less than 4 ft, attach guardrail to traffic side of shoring as shown in the plans. Place ABC in clear distance and around guardrail posts instead of pavement. Do not use temporary guardrail above temporary walls.

(C) Temporary Shoring Designs

Before beginning temporary shoring design, survey existing ground elevations in the vicinity of shoring locations to determine actual design heights (H). Submit 8 copies of working drawings and 3 copies of design calculations and a PDF copy of each for temporary shoring designs in accordance with Article 105-2 of the *2012 Standard Specifications*. Submit working drawings showing plan views, shoring profiles, typical sections and details of temporary shoring design and construction sequence. Do not begin shoring construction until a design submittal is accepted.

Have cantilever and braced shoring designed, detailed and sealed by an engineer licensed in the state of North Carolina. Use a prequalified Anchored Wall Design Consultant to design anchored shoring. Provide anchored shoring designs sealed by a Design Engineer approved as a Geotechnical Engineer (key person) for an Anchored Wall Design Consultant. Include details in anchored shoring working drawings of anchor locations and lock-off loads, unit grout/ground bond strengths for ground anchors or minimum installation torque and torsional strength rating for helical anchors and if necessary, obstructions extending through shoring or interfering with anchors. Include details in the anchored shoring construction sequence of pile and anchor installation, excavation and anchor testing.

Use a prequalified MSE Wall Design Consultant to design temporary walls. Provide temporary wall designs sealed by a Design Engineer approved as a Geotechnical Engineer (key person) for the MSE Wall Design Consultant. Include details in temporary wall working drawings of geotextile and reinforcement types, locations and directions and obstructions extending through walls or interfering with reinforcement.

(1) Soil Parameters

Design temporary shoring for the assumed soil parameters and groundwater elevations shown in the plans. Assume the following soil parameters for shoring backfill:

- (a) Unit weight (γ) = 120 lb/cf;

W-5520

GT-6

Union County

| (b) | Friction Angle (ϕ) | Shoring Backfill |
|-----|---------------------------|-----------------------------------------------|
| | 30° | A-2-4 Soil |
| | 34° | Class II, Type 1 or Class III Select Material |
| | 38° | Class V or VI Select Material |

(c) Cohesion (c) = 0 lb/sf.

(2) Traffic Surcharge

Design temporary shoring for a traffic surcharge of 250 lb/sf if traffic will be above and within H of shoring. This traffic surcharge does not apply to construction traffic. Design temporary shoring for any construction surcharge if construction traffic will be above and within H of shoring. For LRFD shoring designs, apply traffic (live load) surcharge in accordance with Figure C11.5.5-3 of the *AASHTO LRFD Bridge Design Specifications*.

(3) Cantilever, Braced and Anchored Shoring Designs

Use shoring backfill for fill sections and voids between cantilever, braced and anchored shoring and the critical failure surface. Use concrete or grout for embedded portions of drilled-in H-piles. Do not use drilled-in sheet piles.

Define “top of shoring” for cantilever, braced and anchored shoring as where the grade intersects the back of sheet piles or H-piles and timber lagging. Design cantilever, braced and anchored shoring for a traffic impact load of 2,000 lb/ft applied 18" above top of shoring if concrete barrier is above and next to shoring or temporary guardrail is above and attached to shoring. For anchored shoring designs, apply traffic impact load as horizontal load (P_{H1}) in accordance with Figure 3.11.6.3-2(a) of the *AASHTO LRFD specifications*.

Extend cantilever, braced and anchored shoring at least 32" above top of shoring if shoring is designed for traffic impact. Otherwise, extend shoring at least 6" above top of shoring.

Design cantilever, braced and anchored shoring for a maximum deflection of 3" if the horizontal distance to the closest edge of pavement or structure is less than H. Otherwise, design shoring for a maximum deflection of 6". Design cantilever and braced shoring in accordance with the plans and *AASHTO Guide Design Specifications for Bridge Temporary Works*.

Design anchored shoring in accordance with the plans and Article 11.9 of the *AASHTO LRFD Bridge Design Specifications*. Use a resistance factor of 0.80 for tensile resistance of anchors with bars, strands or shafts. Extend the unbonded length for ground anchors and the shallowest helix for helical anchors at least 5 ft behind the critical failure surface. Do not extend anchors beyond right-of-way or easement limits. If existing or future obstructions such as foundations, guardrail

posts, pavements, pipes, inlets or utilities will interfere with anchors, maintain a clearance of at least 6" between obstructions and anchors.

(4) Temporary Wall Designs

Use shoring backfill in the reinforced zone of temporary walls. Separation geotextiles are required between shoring backfill and backfill, natural ground or culverts along the sides of the reinforced zone perpendicular to the wall face. For Class V or VI select material in the reinforced zone, separation geotextiles are also required between shoring backfill and backfill or natural ground on top of and at the back of the reinforced zone.

Design temporary walls in accordance with the plans and Article 11.10 of the *AASHTO LRFD Bridge Design Specifications*. Embed temporary walls at least 18" except for walls on structures or rock as determined by the Engineer. Use a uniform reinforcement length throughout the wall height of at least 0.7H or 6 ft, whichever is longer. Extend the reinforced zone at least 6" beyond end of reinforcement. Do not locate the reinforced zone outside right-of-way or easement limits.

Use the simplified method for determining maximum reinforcement loads in accordance with the AASHTO LRFD specifications. For geotextile reinforcement, use geotextile properties approved by the Department or default values in accordance with the AASHTO LRFD specifications. For geogrid reinforcement, use approved geogrid properties available from the website shown elsewhere in this provision. If the website does not list a short-term design strength for an approved geogrid, use a short-term design strength equal to the ultimate tensile strength divided by 3.5 for the geogrid reinforcement. Use geosynthetic properties for the direction reinforcement will be installed, a 3-year design life and shoring backfill to be used in the reinforced zone.

Do not use more than 4 different reinforcement strengths for each temporary geosynthetic wall. Design temporary geotextile walls for a reinforcement coverage ratio (R_c) of 1.0 and temporary geogrid walls for an R_c of at least 0.8. For geogrid reinforcement with an R_c of less than 1.0, use a maximum horizontal clearance between geogrids of 3 ft and stagger reinforcement so geogrids are centered over gaps in the reinforcement layer below.

For temporary geosynthetic walls, use "L" shaped welded wire facing with 18" to 24" long legs. Locate geotextile or geogrid reinforcement so reinforcement layers are at the same level as the horizontal legs of welded wire facing. Use vertical reinforcement spacing equal to facing height. Wrap geotextile or geogrid reinforcement behind welded wire facing and extend reinforcement at least 3 ft back behind facing into shoring backfill.

For temporary wire walls with separate reinforcement and facing components, attach welded wire grid or metallic strip reinforcement to welded wire facing with

W-5520

GT-8

Union County

a connection approved by the Department. For temporary geogrid and wire walls, retain shoring backfill at welded wire facing with retention geotextiles and extend geotextiles at least 3 ft back behind facing into backfill.

(D) Preconstruction Meeting

The Engineer may require a shoring preconstruction meeting to discuss the construction, inspection and testing of the temporary shoring. If required and if this meeting occurs before all shoring submittals have been accepted, additional preconstruction meetings may be required before beginning construction of temporary shoring without accepted submittals. The Resident, District or Bridge Maintenance Engineer, Bridge or Roadway Construction Engineer, Geotechnical Operations Engineer, Contractor and Shoring Contractor Superintendent will attend preconstruction meetings.

Construction Methods

Control drainage during construction in the vicinity of shoring. Direct run off away from shoring and shoring backfill. Contain and maintain backfill and protect material from erosion.

Install positive protection in accordance with the contract and accepted submittals. Use PCB in accordance with Section 1170 of the *2012 Standard Specifications* and Standard Drawing No. 1170.01 of the *2012 Roadway Standard Drawings*. Use temporary guardrail in accordance with Section 862 of the *2012 Standard Specifications* and Standard Drawing No. 862.01, 862.02 and 862.03 of the *2012 Roadway Standard Drawings*.

(A) Tolerances

Construct shoring with the following tolerances:

- (1) Horizontal wires of welded wire facing are level in all directions,
- (2) Shoring location is within 6" of horizontal and vertical alignment shown in the accepted submittals, and
- (3) Shoring plumbness (batter) is not negative and within 2° of vertical.

(B) Cantilever, Braced and Anchored Shoring Installation

If over excavation behind cantilever, braced or anchored shoring is shown in the accepted submittals, excavate before installing piles. Otherwise, install piles before excavating for shoring. Install cantilever, braced or anchored shoring in accordance with the construction sequence shown in the accepted submittals. Remove piles and if applicable, timber lagging when shoring is no longer needed.

(1) Pile Installation

Install piles with the minimum required embedment and extension in accordance with Subarticles 450-3(D) and 450-3(E) of the *2012 Standard Specifications* except that a pile driving equipment data form is not required. Piles may be installed with a vibratory hammer as approved by the Engineer.

Do not splice sheet piles. Use pile excavation to install drilled-in H-piles. After filling holes with concrete or grout to the elevations shown in the accepted submittals, remove any fluids and fill remaining portions of holes with flowable fill. Cure concrete or grout at least 7 days before excavating.

Notify the Engineer if refusal is reached before pile excavation or driven piles attain the minimum required embedment. When this occurs, a revised design submittal may be required.

(2) Excavation

Excavate in front of piles from the top down in accordance with the accepted submittals. For H-piles with timber lagging and braced and anchored shoring, excavate in staged horizontal lifts with a maximum height of 5 ft. Remove flowable fill and material in between H-piles as needed to install timber lagging. Position lagging with at least 3" of contact in the horizontal direction between the lagging and pile flanges. Do not excavate the next lift until timber lagging for the current lift is installed and if applicable, bracing and anchors for the current lift are accepted. Backfill behind cantilever, braced or anchored shoring with shoring backfill.

(3) Anchor Installation

If applicable, install foundations located behind anchored shoring before installing anchors. Fabricate and install ground anchors in accordance with the accepted submittals, Articles 6.4 and 6.5 of the *AASHTO LRFD Bridge Construction Specifications* and the following unless otherwise approved:

- (a) Materials in accordance with this provision are required instead of materials conforming to Articles 6.4 and 6.5.3 of the AASHTO LRFD Specifications,
- (b) Encapsulation-protected ground anchors in accordance with Article 6.4.1.2 of the AASHTO LRFD specifications are not required, and
- (c) Corrosion protection for unbonded lengths of ground anchors and anchorage covers are not required.
- (d) Measure grout temperature, density and flow during grouting with at least the same frequency grout cubes are made for compressive strength.

W-5520

GT-10

Union County

Perform density and flow field tests in the presence of the Engineer in accordance with American National Standards Institute/American Petroleum Institute Recommended Practice 13B-1 (Section 4, Mud Balance) and ASTM C939 (Flow Cone), respectively.

Install helical anchors in accordance with the accepted submittals and Anchor Manufacturer's instructions. Measure torque during installation and do not exceed the torsional strength rating of the helical anchor. Attain the minimum required installation torque and penetration before terminating anchor installation. When replacing a helical anchor, embed last helix of the replacement anchor at least 3 helix plate diameters past the location of the first helix of the previous anchor.

(4) Anchor Testing

Proof test and lock-off anchors in accordance with the accepted submittals and Article 6.5.5 of the *AASHTO LRFD Bridge Construction Specifications* except for the acceptance criteria in Article 6.5.5.5. For the AASHTO LRFD specifications, "ground anchor" refers to a ground or helical anchor and "tendon" refers to a bar, strand or shaft.

(a) Anchor Acceptance

Anchor acceptance is based in part on the following criteria.

- (i) For ground and helical anchors, total movement is less than 0.04" between the 1 and 10 minute readings or less than 0.08" between the 6 and 60 minute readings.
- (ii) For ground anchors, total movement at maximum test load exceeds 80% of the theoretical elastic elongation of the unbonded length.

(b) Anchor Test Results

Submit 2 copies of anchor test records including movement versus load plots for each load increment within 24 hours of completing each row of anchors. The Engineer will review the test records to determine if the anchors are acceptable.

If the Engineer determines an anchor is unacceptable, revise the anchor design or installation methods. Submit a revised anchored shoring design for acceptance and provide an acceptable anchor with the revised design or installation methods. If required, replace the anchor or provide additional anchors with the revised design or installation methods.

W-5520

GT-11

Union County

(C) Temporary Wall Installation

Excavate as necessary for temporary walls in accordance with the plans and accepted submittals. If applicable, install foundations located in the reinforced zone before placing shoring backfill or reinforcement unless otherwise approved. Notify the Engineer when foundation excavation is complete. Do not place shoring backfill or reinforcement until excavation dimensions and foundation material are approved.

Erect welded wire facing so the wall position is as shown in the plans and accepted submittals. Set welded wire facing adjacent to each other in the horizontal and vertical direction to completely cover the wall face with facing. Stagger welded wire facing to create a running bond by centering facing over joints in the row below.

Wrap geotextile reinforcement and retention geotextiles behind welded wire facing as shown in the plans and accepted submittals and cover geotextiles with at least 3" of shoring backfill. Overlap adjacent geotextile reinforcement and retention and separation geotextiles at least 18" with seams oriented perpendicular to the wall face. Hold geotextiles in place with wire staples or anchor pins as needed.

Place reinforcement within 3" of locations shown in the plans and accepted submittals and in slight tension free of kinks, folds, wrinkles or creases. Install reinforcement with the direction shown in the plans and accepted submittals. For temporary wire walls with separate reinforcement and facing components, attach welded wire grid or metallic strip reinforcement to welded wire facing as shown in the accepted submittals. Do not splice or overlap reinforcement so seams are parallel to the wall face. Contact the Engineer when unanticipated existing or future obstructions such as foundations, pavements, pipes, inlets or utilities will interfere with reinforcement.

Place shoring backfill in the reinforced zone in 8" to 10" thick lifts. Compact A-2-4 soil and Class II, Type 1 and Class III select material in accordance with Subarticle 235-3(C) of the *2012 Standard Specifications*. Use only hand operated compaction equipment to compact backfill within 3 ft of welded wire facing. At a distance greater than 3 ft, compact shoring backfill with at least 4 passes of an 8 ton to 10 ton vibratory roller in a direction parallel to the wall face. Smooth wheeled or rubber tired rollers are also acceptable for compacting backfill. Do not use sheepsfoot, grid rollers or other types of compaction equipment with feet. Do not displace or damage reinforcement when placing and compacting shoring backfill. End dumping directly on geotextile or geogrid reinforcement is not permitted. Do not operate heavy equipment on reinforcement until it is covered with at least 8" of shoring backfill. Replace any damaged reinforcement to the satisfaction of the Engineer.

Backfill for temporary walls outside the reinforced zone in accordance with Article 410-8 of the *2012 Standard Specifications*. Bench temporary walls into the sides of excavations where applicable. For temporary geosynthetic walls with top of wall within 5 ft of finished grade, remove top facing and incorporate top reinforcement layer into fill when placing fill in front of wall. Temporary walls remain in place permanently unless otherwise required.

W-5520

GT-12

Union County

Measurement and Payment

Temporary Shoring will be measured and paid in square feet. Temporary walls will be measured as the square feet of exposed wall face area. Cantilever, braced or anchored shoring will be measured as the square feet of exposed shoring face area with the shoring height equal to the difference between the top and bottom of shoring elevations. Define “top of shoring” as where the grade intersects the back of sheet piles or H-piles and timber lagging. Define “bottom of shoring” as where the grade intersects front of sheet piles or H-piles and timber lagging. No measurement will be made for any embedment, shoring extension above top of shoring or pavement thickness above temporary walls.

The contract unit price for *Temporary Shoring* will be full compensation for providing shoring designs, submittals and materials, excavating, backfilling, hauling and removing excavated materials and supplying all labor, tools, equipment and incidentals necessary to construct temporary shoring.

No payment will be made for temporary shoring not shown in the plans or required by the Engineer including shoring for OSHA reasons or the Contractor’s convenience. No value engineering proposals will be accepted based solely on revising or eliminating shoring locations shown in the plans or estimated quantities shown in the bid item sheets as a result of actual field measurements or site conditions.

PCB will be measured and paid in accordance with Section 1170 of the *2012 Standard Specifications*. No additional payment will be made for anchoring PCB for temporary shoring. Costs for anchoring PCB will be incidental to temporary shoring.

Temporary guardrail will be measured and paid for in accordance with Section 862 of the *2012 Standard Specifications*.

Payment will be made under:

Pay Item

Temporary Shoring

Pay Unit

Square Foot

W-5520

GT-13

Union County

CAST-IN-PLACE GRAVITY RETAINING WALLS**(3-17-15)****1.0 GENERAL**

Construct cast-in-place (CIP) gravity retaining walls consisting of CIP concrete supported by and connected to concrete footings. Construct CIP gravity retaining walls based on actual elevations and wall dimensions in accordance with the contract, accepted submittals and if included in the plans, Standard Detail No. 453.01. Define “CIP gravity wall” as a CIP gravity retaining wall.

2.0 MATERIALS

Refer to Division 10 of the *Standard Specifications*.

| Item | Section |
|-----------------------------------|----------------|
| Curing Agents | 1026 |
| Geotextiles, Type 1 | 1056 |
| Joint Materials | 1028 |
| Masonry | 1040 |
| Portland Cement Concrete, Class A | 1000 |
| Reinforcing Steel | 1070 |
| Subdrain Coarse Aggregate | 1044-2 |
| Subdrain Fine Aggregate | 1044-1 |

Use geotextiles and subdrain aggregate for subsurface drainage at weep holes and reinforcing steel for dowels.

3.0 CIP GRAVITY WALL SURVEYS

The plans typically show a plan view, typical sections, details, notes and an elevation or profile view (wall envelope) for each CIP gravity wall. Before beginning CIP gravity wall construction, survey existing ground elevations along wall face locations and other elevations in the vicinity of CIP gravity wall locations as needed. For proposed slopes above or below CIP gravity walls, survey existing ground elevations to at least 10 ft beyond slope stake points. Based on these elevations, finished grades and actual CIP gravity wall dimensions and details, submit wall envelopes for acceptance. Use accepted wall envelopes for construction.

4.0 CONSTRUCTION METHODS

Control drainage during construction in the vicinity of CIP gravity walls. Direct run off away from CIP gravity walls and backfill. Contain and maintain backfill and protect material from erosion.

Excavate as necessary for CIP gravity walls in accordance with the plans. Unless required otherwise in the plans, embed bottom of footings at least 2 ft below bottom of walls shown in the plans. If applicable and at the Contractor’s option, use temporary shoring for wall construction instead of temporary slopes to construct CIP gravity walls. Define “temporary

W-5520

GT-14

Union County

shoring for wall construction” as temporary shoring not shown in the plans or required by the Engineer including shoring for OSHA reasons or the Contractor’s convenience.

Notify the Engineer when foundation excavation is complete. Do not place concrete for footings until excavation depth and foundation material are approved.

Construct CIP gravity walls at elevations and with dimensions shown in the plans and in accordance with Section 420 of the *Standard Specifications*. Use dowels for construction joints at top of footings as shown in the plans. Extend top of walls at least 6" above where finished grade intersects back of CIP gravity walls.

Unless required otherwise in the plans, provide a Class 2 surface finish for exposed surfaces of CIP gravity walls that meets Subarticle 420-17(F) of the *Standard Specifications*. Construct wall joints at a spacing of 10 ft to 12 ft unless required otherwise in the plans. Make 1/2" thick expansion joints that meet Article 420-10 of the *Standard Specifications* for every third joint and 1/2" deep grooved contraction or sawed joints that meet Subarticle 825-10(B) or 825-10(E) respectively of the *Standard Specifications* for the remaining joints.

Construct 3" diameter weep holes on 10 ft centers along CIP gravity walls. Provide subsurface drainage at weep holes in accordance with Article 414-8 of the *Standard Specifications*. Exit weep holes just above finished grade and slope holes at 1" per foot through CIP gravity walls so water drains out of front of walls. When single faced precast concrete barrier is required in front of and against CIP gravity walls, extend weep holes through barrier at the same slope.

Do not remove forms or backfill behind CIP gravity walls until concrete attains a compressive strength of at least 2,400 psi. Backfill for CIP gravity walls in accordance with Article 410-8 of the *Standard Specifications*.

If a brick veneer is required, construct brick masonry in accordance with Section 830 of the *Standard Specifications*. Anchor brick veneers to CIP gravity walls with approved brick to concrete type anchors in accordance with the manufacturer’s instructions. Space anchors no more than 16" apart in the vertical direction and no more than 32" apart in the horizontal direction with each row of anchors staggered 16" from the row above and below.

5.0 MEASUREMENT AND PAYMENT

CIP Gravity Retaining Walls will be measured and paid in square feet. CIP gravity walls will be measured as the square feet of wall face area with the pay height equal to the difference between top of wall and top of footing elevations. Define “top of wall” as top of CIP concrete.

The contract unit price for *CIP Gravity Retaining Walls* will be full compensation for providing submittals, labor, tools, equipment and CIP gravity wall materials, excavating, backfilling, hauling and removing excavated materials and supplying concrete, dowels, subsurface drainage, weep holes and any incidentals necessary to construct CIP gravity walls. The contract unit price for *CIP Gravity Retaining Walls* will also be full

W-5520

GT-15

Union County

compensation for brick veneers, if required.

No separate payment will be made for temporary shoring for wall construction. Temporary shoring for wall construction will be incidental to the contract unit price for *CIP Gravity Retaining Walls*.

The contract unit price for *CIP Gravity Retaining Walls* does not include the cost for ditches, fences, handrails, barrier or guardrail associated with CIP gravity walls as these items will be paid for elsewhere in the contract.

Where it is necessary to provide backfill material from sources other than excavated areas or borrow sources used in connection with other work in the contract, payment for furnishing and hauling such backfill material will be paid as extra work in accordance with Article 104-7 of the *Standard Specifications*. Placing and compacting such backfill material is not considered extra work but is incidental to the work being performed.

Payment will be made under:

Pay Item
CIP Gravity Retaining Walls

Pay Unit
Square Foot



Luis Campos

2/1/2017

PM-1



DocuSigned by:
Renee Roach
B3C6C6F7CF4640D...

1/19/2017

IN LANE ROUTE SHIELDS:

(01/18/2017)

Description

This work shall consist of applying NCDOT approved In Lane Route Shields in accordance with Section 1205 of the *2012 Standard Specifications*.

Application

Install Heated-In-Place Thermoplastic In Lane Route Shields that are capable of adhering to both asphalt and concrete pavements. Installation shall be in accordance with the manufacturer's specifications.

Measurement and Payment

In Lane Route Shields will be measured and paid for in units of each that have been satisfactorily placed and accepted.

Add the following pay item:

Pay Item

In Lane Route Shields

Pay Unit

Each

TC-1

WORK ZONE TRAFFIC CONTROL Project Special Provisions

LAW ENFORCEMENT:

(02/06/13)

Description

Furnish Law Enforcement Officers and marked Law Enforcement vehicles direct traffic in accordance with the contract.

Construction Methods

Use uniformed Law Enforcement Officers and marked Law Enforcement vehicles equipped with blue lights mounted on top of the vehicle, and Law Enforcement vehicle emblems to direct or control traffic as required by the plans or by the Engineer.

Measurement and Payment

Law Enforcement will be measured and paid for in the actual number of hours that each Law Enforcement Officer is provided during the life of the project as approved by the Engineer. There will be no direct payment for marked Law Enforcement vehicles as they are considered incidental to the pay item.

Payment will be made under:

| Pay Item | Pay Unit |
|-----------------|----------|
| Law Enforcement | Hour |

DocuSigned by:
Steve Kite
E27CE30E1DFC442...

10/22/2014



PROJECT SPECIAL PROVISIONS
Utility Construction



**DOCUMENT NOT CONSIDERED FINAL
UNLESS ALL SIGNATURES COMPLETED**

Revise the 2012 Standard Specifications as follows

Page 10-58, Sub-article 1036-1 General

add the following sentence:

All materials in contact with potable water shall be in conformance with Section 1417 of the Safe Drinking Water Act.

Page 15-1, Sub-article 1500-2 Cooperation with the Utility Owner, paragraph 2:

add the following sentences:

The utility owner is Union County Public Works. The contact person for Union County Public Works is Michael Caldwell and he can be reached by phone at (704) 296-4293.

Page 15-2, Sub-article 1500-9 Placing Pipelines into Service

add the following sentence:

Obtain approval from the NCDENR-Public Water Supply Section prior to placing a new water line into service. Use backflow prevention assemblies for temporary connections to isolate new water lines from existing water line.

Page 15-6, Sub-article 1510-3 (B), Testing and Sterilization

change the allowable leakage formula to:

$$W = LD\sqrt{P} \div 148,000$$

PROJECT SPECIAL PROVISIONS

Utility Construction

Page 15-6, Sub-article 1510-3 (B), Testing and Sterilization, sixth paragraph:

Replace the paragraph with the following:

Sterilize water lines in accordance with Section 1003 of The Rules Governing Public Water supply and AWWA C651 Section 4.4.3, the Continuous Feed Method. Provide a chlorine solution with between 50 parts per million and 100 parts per million in the initial feed. If the chlorine level drops below 10 parts per million during a 24 hour period, then flush, refill with fresh chlorine solution, and repeat for 24 hours. Provide certified bacteriological and contaminant test results from a state-approved or state-certified laboratory. Operate all valves and controls to assure thorough sterilization.

Page 15-6, Sub-article 1510-3 (B), Testing and Sterilization, seventh paragraph:

delete the words “may be performed concurrently or consecutively.”

and replace with “shall be performed consecutively.”

Page 15-7, Article 1510-4 MEASUREMENT AND PAYMENT, add the following paragraph after line 7:

The quantity of *Ductile Iron Water Pipe Fittings* will be measured and paid per pound based on the published weights for ductile iron fittings, exclusive of the weights of any accessories, as listed in the “DI Fittings Weight Chart” located at the NCDOT Utilities web site. If the Contractor elects to use compact ductile iron water pipe fittings, measurement will be based on the weight of standard size ductile iron water pipe fittings. Any fitting not listed will be measured based on the published weights for ductile iron fittings listed in ANSI/AWWA C-110/A21.10. This is limited to pressure pipe 4 inches or larger.

Page 15-7, Article 1510-4 MEASUREMENT AND PAYMENT, add the following pay item:

Pay Item

Ductile Iron Water Pipe Fittings

Pay Unit

Pound

PROJECT SPECIAL PROVISIONS

Utilities by Others

**General:**

The following utility companies have facilities that will be in conflict with the construction of this project:

- A. Power – Duke Energy
- B. Power – Union Power
- C. Telecommunications – Windstream
- D. Cable – Time Warner Cable
- E. Gas - PNG

The conflicting facilities of these concerns will be adjusted prior to the date of availability, unless otherwise noted and are therefore listed in these special provisions for the benefit of the Contractor. All utility work listed herein will be done by the utility owners. All utilities are shown on the plans from the best available information.

The Contractor's attention is directed to Article 105.8 of the 2012 Standard Specifications.

Utilities Requiring Adjustment:

Utility relocations are shown on the Utilities by Others Plans.

A. Progress Energy

- 1. Contact person for Duke Energy is Larry Robinson at 336.209.6631
- 2. Facilities have been relocated prior to Date of Availability.

B. Union Power

- 1. Contact person for Union Power is Mark McClamrock at 704.289.3145 ext 3255
- 2. Facilities to be relocated prior to Date of Availability.

PROJECT SPECIAL PROVISIONS

Utilities by Others

C. Windstream

1. Contact person for Windstream is Michael Ewing at 704.845.7652
2. Facilities to be relocated prior to Date of Availability.

D. Time Warner Cable

1. Contact person for Time Warner Cable is Dan Owens at 803.548.7547
2. Facilities to be relocated prior to Date of Availability.

E. Piedmont Natural Gas (PNG)

1. Contact for Piedmont Natural Gas is Joseph Heckman at 252.646.5438
2. Mainline facilities to be relocated prior to Date of Availability. Gas services crossing 74 may also need relocating. These will need to be relocated during construction if needed. PNG requires 3 day notice and typically 1 week to complete work

**Project Special Provisions
Erosion Control**

STABILIZATION REQUIREMENTS:

(3-11-2016)

Stabilization for this project shall comply with the time frame guidelines as specified by the NCG-010000 general construction permit effective August 3, 2011 issued by the North Carolina Department of Environment and Natural Resources Division of Water Quality. Temporary or permanent ground cover stabilization shall occur within 7 calendar days from the last land-disturbing activity, with the following exceptions in which temporary or permanent ground cover shall be provided in 14 calendar days from the last land-disturbing activity:

- Slopes between 2:1 and 3:1, with a slope length of 10 ft. or less
- Slopes 3:1 or flatter, with a slope of length of 50 ft. or less
- Slopes 4:1 or flatter

The stabilization timeframe for High Quality Water (HQW) Zones shall be 7 calendar days with no exceptions for slope grades or lengths. High Quality Water Zones (HQW) Zones are defined by North Carolina Administrative Code 15A NCAC 04A.0105 (25). Temporary and permanent ground cover stabilization shall be achieved in accordance with the provisions in this contract and as directed.

SEEDING AND MULCHING:

(East)

The kinds of seed and fertilizer, and the rates of application of seed, fertilizer, and limestone, shall be as stated below. During periods of overlapping dates, the kind of seed to be used shall be determined. All rates are in pounds per acre.

All Roadway Areas

March 1 - August 31

50# Tall Fescue
 10# Centipede
 25# Bermudagrass (hulled)
 500# Fertilizer
 4000# Limestone

September 1 - February 28

50# Tall Fescue
 10# Centipede
 35# Bermudagrass (unhulled)
 500# Fertilizer
 4000# Limestone

Waste and Borrow Locations

March 1 – August 31

75# Tall Fescue
 25# Bermudagrass (hulled)
 500# Fertilizer
 4000# Limestone

September 1 - February 28

75# Tall Fescue
 35# Bermudagrass (unhulled)
 500# Fertilizer
 4000# Limestone

Note: 50# of Bahiagrass may be substituted for either Centipede or Bermudagrass only upon Engineer's request.

Approved Tall Fescue Cultivars

| | | | |
|----------------------------|-----------------|-----------------|--------------------|
| 06 Dust | Escalade | Justice | Serengeti |
| 2 nd Millennium | Essential | Kalahari | Shelby |
| 3 rd Millennium | Evergreen 2 | Kitty Hawk 2000 | Sheridan |
| Apache III | Falcon IV | Legitimate | Signia |
| Avenger | Falcon NG | Lexington | Silver Hawk |
| Barlexas | Falcon V | LSD | Sliverstar |
| Barlexas II | Faith | Magellan | Shenandoah Elite |
| Bar Fa | Fat Cat | Matador | Sidewinder |
| Barrera | Festnova | Millennium SRP | Skyline |
| Barrington | Fidelity | Monet | Solara |
| Barrobusto | Finelawn Elite | Mustang 4 | Southern Choice II |
| Barvado | Finelawn Xpress | Ninja 2 | Speedway |
| Biltmore | Finesse II | Ol' Glory | Spyder LS |
| Bingo | Firebird | Olympic Gold | Sunset Gold |
| Bizem | Firecracker LS | Padre | Taccoa |
| Blackwatch | Firenza | Patagonia | Tanzania |
| Blade Runner II | Five Point | Pedigree | Trio |
| Bonsai | Focus | Picasso | Tahoe II |
| Braveheart | Forte | Piedmont | Talladega |
| Bravo | Garrison | Plantation | Tarheel |
| Bullseye | Gazelle II | Proseeds 5301 | Terrano |
| Cannavaro | Gold Medallion | Prospect | Titan ltd |
| Catalyst | Grande 3 | Pure Gold | Titanium LS |
| Cayenne | Greenbrooks | Quest | Tracer |
| Cessane Rz | Greenkeeper | Raptor II | Traverse SRP |
| Chipper | Gremlin | Rebel Exeda | Tulsa Time |
| Cochise IV | Greystone | Rebel Sentry | Turbo |
| Constitution | Guardian 21 | Rebel IV | Turbo RZ |
| Corgi | Guardian 41 | Regiment II | Tuxedo RZ |
| Corona | Hemi | Regenerate | Ultimate |
| Coyote | Honky Tonk | Rendition | Venture |
| Darlington | Hot Rod | Rhambler 2 SRP | Umbrella |
| Davinci | Hunter | Rembrandt | Van Gogh |
| Desire | Inferno | Reunion | Watchdog |
| Dominion | Innovator | Riverside | Wolfpack II |
| Dynamic | Integrity | RNP | Xtremegreen |
| Dynasty | Jaguar 3 | Rocket | |
| Endeavor | Jamboree | Scorpion | |

On cut and fill slopes 2:1 or steeper Centipede shall be applied at the rate of 5 pounds per acre and add 20# of Sericea Lespedeza from January 1 - December 31.

Fertilizer shall be 10-20-20 analysis. A different analysis of fertilizer may be used provided the 1-2-2 ratio is maintained and the rate of application adjusted to provide the same amount of plant food as a 10-20-20 analysis and as directed.

Native Grass Seeding And Mulching (West)

Native Grass Seeding and Mulching shall be performed on the disturbed areas of wetlands and riparian areas, and adjacent to Stream Relocation and/or trout stream construction within a 50 foot zone on both sides of the stream or depression, measured from top of stream bank or center of depression. The stream bank of the stream relocation shall be seeded by a method that does not alter the typical cross section of the stream bank. Native Grass Seeding and Mulching shall also be performed in the permanent soil reinforcement mat section of preformed scour holes, and in other areas as directed.

The kinds of seed and fertilizer, and the rates of application of seed, fertilizer, and limestone, shall be as stated below. During periods of overlapping dates, the kind of seed to be used shall be determined. All rates are in pounds per acre.

| August 1 - June 1 | | May 1 – September 1 | |
|--------------------------|---------------------|----------------------------|---------------------------|
| 18# | Creeping Red Fescue | 18# | Creeping Red Fescue |
| 8# | Big Bluestem | 8# | Big Bluestem |
| 6# | Indiangrass | 6# | Indiangrass |
| 4# | Switchgrass | 4# | Switchgrass |
| 35# | Rye Grain | 25# | German or Browntop Millet |
| 500# | Fertilizer | 500# | Fertilizer |
| 4000# | Limestone | 4000# | Limestone |

Approved Creeping Red Fescue Cultivars:

- | | | | |
|----------|--------|------|-----------|
| Aberdeen | Boreal | Epic | Cindy Lou |
|----------|--------|------|-----------|

Fertilizer shall be 10-20-20 analysis. A different analysis of fertilizer may be used provided the 1-2-2 ratio is maintained and the rate of application adjusted to provide the same amount of plant food as a 10-20-20 analysis and as directed.

Native Grass Seeding and Mulching shall be performed in accordance with Section 1660 of the *Standard Specifications* and vegetative cover sufficient to restrain erosion shall be installed immediately following grade establishment.

Measurement and Payment

Native Grass *Seeding and Mulching* will be measured and paid for in accordance with Article 1660-8 of the *Standard Specifications*.

TEMPORARY SEEDING:

Fertilizer shall be the same analysis as specified for *Seeding and Mulching* and applied at the rate of 400 pounds and seeded at the rate of 50 pounds per acre. Sweet Sudan Grass, German Millet or Browntop Millet shall be used in summer months and Rye Grain during the remainder of the year. The Engineer will determine the exact dates for using each kind of seed.

FERTILIZER TOPDRESSING:

Fertilizer used for topdressing on all roadway areas except slopes 2:1 and steeper shall be 10-20-20 grade and shall be applied at the rate of 500 pounds per acre. A different analysis of fertilizer may be used provided the 1-2-2 ratio is maintained and the rate of application adjusted to provide the same amount of plant food as 10-20-20 analysis and as directed.

Fertilizer used for topdressing on slopes 2:1 and steeper and waste and borrow areas shall be 16-8-8 grade and shall be applied at the rate of 500 pounds per acre. A different analysis of fertilizer may be used provided the 2-1-1 ratio is maintained and the rate of application adjusted to provide the same amount of plant food as 16-8-8 analysis and as directed.

SUPPLEMENTAL SEEDING:

The kinds of seed and proportions shall be the same as specified for *Seeding and Mulching*, with the exception that no centipede seed will be used in the seed mix for supplemental seeding. The rate of application for supplemental seeding may vary from 25# to 75# per acre. The actual rate per acre will be determined prior to the time of topdressing and the Contractor will be notified in writing of the rate per acre, total quantity needed, and areas on which to apply the supplemental seed. Minimum tillage equipment, consisting of a sod seeder shall be used for incorporating seed into the soil as to prevent disturbance of existing vegetation. A clodbuster (ball and chain) may be used where degree of slope prevents the use of a sod seeder.

MOWING:

The minimum mowing height on this project shall be 4 inches.

RESPONSE FOR EROSION CONTROL:**Description**

Furnish the labor, materials, tools and equipment necessary to move personnel, equipment, and supplies to the project necessary for the pursuit of any or all of the following work as shown herein, by an approved subcontractor.

| Section | Erosion Control Item | Unit |
|----------------|--------------------------------|-------------|
| 1605 | Temporary Silt Fence | LF |
| 1606 | Special Sediment Control Fence | LF/TON |

| | | |
|------|----------------------------------|-----|
| 1615 | Temporary Mulching | ACR |
| 1620 | Seed - Temporary Seeding | LB |
| 1620 | Fertilizer - Temporary Seeding | TN |
| 1631 | Matting for Erosion Control | SY |
| SP | Coir Fiber Mat | SY |
| 1640 | Coir Fiber Baffles | LF |
| SP | Permanent Soil Reinforcement Mat | SY |
| 1660 | Seeding and Mulching | ACR |
| 1661 | Seed - Repair Seeding | LB |
| 1661 | Fertilizer - Repair Seeding | TON |
| 1662 | Seed - Supplemental Seeding | LB |
| 1665 | Fertilizer Topdressing | TON |
| SP | Safety/Highly Visible Fencing | LF |
| SP | Response for Erosion Control | EA |

Construction Methods

Provide an approved subcontractor who performs an erosion control action as described in the NPDES Inspection Form SPPP30. Each erosion control action may include one or more of the above work items.

Measurement and Payment

Response for Erosion Control will be measured and paid for by counting the actual number of times the subcontractor moves onto the project, including borrow and waste sites, and satisfactorily completes an erosion control action described in Form 1675. The provisions of Article 104-5 of the *Standard Specifications* will not apply to this item of work.

Payment will be made under:

Pay Item

Response for Erosion Control

Pay Unit

Each

MINIMIZE REMOVAL OF VEGETATION:

The Contractor shall minimize removal of vegetation within project limits to the maximum extent practicable. Vegetation along stream banks and adjacent to other jurisdictional resources outside the construction limits shall only be removed upon approval of Engineer. No additional payment will be made for this minimization work.

STOCKPILE AREAS:

The Contractor shall install and maintain erosion control devices sufficient to contain sediment around any erodible material stockpile areas as directed.

ACCESS AND HAUL ROADS:

At the end of each working day, the Contractor shall install or re-establish temporary diversions or earth berms across access/haul roads to direct runoff into sediment devices. Silt fence sections that are temporarily removed shall be reinstalled across access/haul roads at the end of each working day.

WASTE AND BORROW SOURCES:

Payment for temporary erosion control measures, except those made necessary by the Contractor's own negligence or for his own convenience, will be paid for at the appropriate contract unit price for the devices or measures utilized in borrow sources and waste areas.

No additional payment will be made for erosion control devices or permanent seeding and mulching in any commercial borrow or waste pit. All erosion and sediment control practices that may be required on a commercial borrow or waste site will be done at the Contractor's expense.

All offsite Staging Areas, Borrow and Waste sites shall be in accordance with "Borrow and Waste Site Reclamation Procedures for Contracted Projects" located at:

http://www.ncdot.gov/doh/operations/dp_chief_eng/roadside/fieldops/downloads/Files/ContractedReclamationProcedures.pdf

All forms and documents referenced in the "Borrow and Waste Site Reclamation Procedures for Contracted Projects" shall be included with the reclamation plans for offsite staging areas, and borrow and waste sites.

SAFETY FENCE AND JURISDICTIONAL FLAGGING:**Description**

Safety Fence shall consist of furnishing materials, installing and maintaining polyethylene or polypropylene fence along the outside riparian buffer, wetland, or water boundary, or other boundaries located within the construction corridor to mark the areas that have been approved to infringe within the buffer, wetland, endangered vegetation, culturally sensitive areas or water. The fence shall be installed prior to any land disturbing activities.

Interior boundaries for jurisdictional areas noted above shall be delineated by stakes and highly visible flagging.

Jurisdictional boundaries at staging areas, waste sites, or borrow pits, whether considered outside or interior boundaries shall be delineated by stakes and highly visible flagging.

Materials

(A) Safety Fencing

Polyethylene or polypropylene fence shall be a highly visible preconstructed safety fence approved by the Engineer. The fence material shall have an ultraviolet coating.

Either wood posts or steel posts may be used. Wood posts shall be hardwood with a wedge or pencil tip at one end, and shall be at least 5 ft. in length with a minimum nominal 2" x 2" cross section. Steel posts shall be at least 5 ft. in length, and have a minimum weight of 0.85 lb/ft of length.

(B) Boundary Flagging

Wooden stakes shall be 4 feet in length with a minimum nominal 3/4" x 1-3/4" cross section. The flagging shall be at least 1" in width. The flagging material shall be vinyl and shall be orange in color and highly visible.

Construction Methods

No additional clearing and grubbing is anticipated for the installation of this fence. The fence shall be erected to conform to the general contour of the ground.

(A) Safety Fencing

Posts shall be set at a maximum spacing of 10 ft., maintained in a vertical position and hand set or set with a post driver. Posts shall be installed a minimum of 2 ft. into the ground. If hand set, all backfill material shall be thoroughly tamped. Wood posts may be sharpened to a dull point if power driven. Posts damaged by power driving shall be removed and replaced prior to final acceptance. The tops of all wood posts shall be cut at a 30-degree angle. The wood posts may, at the option of the Contractor, be cut at this angle either before or after the posts are erected.

The fence geotextile shall be attached to the wood posts with one 2" galvanized wire staple across each cable or to the steel posts with wire or other acceptable means.

Place construction stakes to establish the location of the safety fence in accordance with Article 105-9 or Article 801-1 of the *Standard Specifications*. No direct pay will be made for the staking of the safety fence. All stakeouts for safety fence shall be considered incidental to the work being paid for as "Construction Surveying", except that where there is no pay item for construction surveying, all safety fence stakeout will be performed by state forces.

The Contractor shall be required to maintain the safety fence in a satisfactory condition for the duration of the project as determined by the Engineer.

(B) Boundary Flagging

Boundary flagging delineation of interior boundaries shall consist of wooden stakes on 25 feet maximum intervals with highly visible orange flagging attached. Stakes shall be installed a minimum of 6" into the ground. Interior boundaries may be staked on a tangent that runs parallel to buffer but must not encroach on the buffer at any location. Interior boundaries of hand clearing shall be identified with a different colored flagging to distinguish it from mechanized clearing.

Boundary flagging delineation of interior boundaries will be placed in accordance with Article 105-9 or Article 801-1 of the *Standard Specifications*. No direct pay will be made for delineation of the interior boundaries. This delineation will be considered incidental to the work being paid for as *Construction Surveying*, except that where there is no pay item or construction surveying the cost of boundary flagging delineation shall be included in the unit prices bid for the various items in the contract. Installation for delineation of all jurisdictional boundaries at staging areas, waste sites, or borrow pits shall consist of wooden stakes on 25 feet maximum intervals with highly visible orange flagging attached. Stakes shall be installed a minimum of 6" into the ground. Additional flagging may be placed on overhanging vegetation to enhance visibility but does not substitute for installation of stakes.

Installation of boundary flagging for delineation of all jurisdictional boundaries at staging areas, waste sites, or borrow pits shall be performed in accordance with Subarticle 230-4(B)(5) or Subarticle 802-2(F) of the *Standard Specifications*. No direct pay will be made for this delineation, as the cost of same shall be included in the unit prices bid for the various items in the contract.

The Contractor shall be required to maintain alternative stakes and highly visible flagging in a satisfactory condition for the duration of the project as determined by the Engineer.

Measurement and Payment

Safety Fence will be measured and paid as the actual number of linear feet of polyethylene or polypropylene fence installed in place and accepted. Such payment will be full compensation including but not limited to furnishing and installing fence geotextile with necessary posts and post bracing, staples, tie wires, tools, equipment and incidentals necessary to complete this work.

Payment will be made under:

| Pay Item | Pay Unit |
|-----------------|-----------------|
| Safety Fence | Linear Foot |

PERMANENT SOIL REINFORCEMENT MAT:**Description**

This work consists of furnishing and placing *Permanent Soil Reinforcement Mat*, of the type specified, over previously prepared areas as directed.

Materials

The product shall be a permanent erosion control reinforcement mat and shall be constructed of synthetic or a combination of coconut and synthetic fibers evenly distributed throughout the mat between a bottom UV stabilized netting and a heavy duty UV stabilized top net. The matting shall be stitched together with UV stabilized polypropylene thread to form a permanent three-dimensional structure. The mat shall have the following minimum physical properties:

| Property | Test Method | Value | Unit |
|----------------------------------------------|------------------------|--------------|--------------------|
| Light Penetration | ASTM D6567 | 9 | % |
| Thickness | ASTM D6525 | 0.40 | in |
| Mass Per Unit Area | ASTM D6566 | 0.55 | lb/sy |
| Tensile Strength | ASTM D6818 | 385 | lb/ft |
| Elongation (Maximum) | ASTM D6818 | 49 | % |
| Resiliency | ASTM D1777 | >70 | % |
| UV Stability * | ASTM D4355 | ≥80 | % |
| Porosity (Permanent Net) | ECTC Guidelines | ≥85 | % |
| Maximum Permissible Shear Stress (Vegetated) | Performance Bench Test | ≥8.0 | lb/ft ² |
| Maximum Allowable Velocity (Vegetated) | Performance Bench Test | ≥16.0 | ft/s |

*ASTM D1682 Tensile Strength and % strength retention of material after 1000 hours of exposure.

Submit a certification (Type 1, 2, or 3) from the manufacturer showing:

- (A) the chemical and physical properties of the mat used, and
- (B) conformance of the mat with this specification.

Construction Methods

Matting shall be installed in accordance with Subarticle 1631-3(B) of the *Standard Specifications*.

All areas to be protected with the mat shall be brought to final grade and seeded in accordance with Section 1660 of the *Standard Specifications*. The surface of the soil shall be smooth, firm, stable and free of rocks, clods, roots or other obstructions that would prevent the mat from lying

in direct contact with the soil surface. Areas where the mat is to be placed will not need to be mulched.

Measurement and Payment

Permanent Soil Reinforcement Mat will be measured and paid for as the actual number of square yards measured along the surface of the ground over which Permanent Soil Reinforcement Mat is installed and accepted. Overlaps will not be included in the measurement, and will be considered as incidental to the work. Such payment shall be full compensation for furnishing and installing the mat, including overlaps, and for all required maintenance.

Payment will be made under:

| Pay Item | Pay Unit |
|----------------------------------|-----------------|
| Permanent Soil Reinforcement Mat | Square Yard |

WATTLES WITH POLYACRYLAMIDE (PAM):

Description

Wattles are tubular products consisting of excelsior fibers encased in synthetic netting. Wattles are used on slopes or channels to intercept runoff and act as a velocity break. Wattles are to be placed at locations shown on the plans or as directed. Installation shall follow the detail provided in the plans and as directed. Work includes furnishing materials, installation of wattles, matting installation, PAM application, and removing wattles.

Materials

Wattle shall meet the following specifications:

| | |
|-------------------------------------|----------------------------------|
| 100% Curled Wood (Excelsior) Fibers | |
| Minimum Diameter | 12 in. |
| Minimum Density | 2.5 lb/ft ³ +/- 10% |
| Net Material | Synthetic |
| Net Openings | 1 in. x 1 in. |
| Net Configuration | Totally Encased |
| Minimum Weight | 20 lb. +/- 10% per 10 ft. length |

Anchors: Stakes shall be used as anchors.

Wooden Stakes:

Provide hardwood stakes a minimum of 2-ft. long with a 2 in. x 2 in. nominal square cross section. One end of the stake must be sharpened or beveled to facilitate driving down into the underlying soil.

Matting shall meet the requirements of Article 1060-8 of the *Standard Specifications*, or shall meet specifications provided elsewhere in this contract.

Provide staples made of 0.125" diameter new steel wire formed into a *u* shape not less than 12" in length with a throat of 1" in width.

Polyacrylamide (PAM) shall be applied in powder form and shall be anionic or neutrally charged. Soil samples shall be obtained in areas where the wattles will be placed, and from offsite material used to construct the roadway, and analyzed for the appropriate PAM flocculant to be utilized with each wattle. The PAM product used shall be listed on the North Carolina Department of Environment and Natural Resources (NCDENR) Division of Water Quality (DWQ) web site as an approved PAM product for use in North Carolina.

Construction Methods

Wattles shall be secured to the soil by wire staples approximately every 1 linear foot and at the end of each section of wattle. A minimum of 4 stakes shall be installed on the downstream side of the wattle with a maximum spacing of 2 linear feet along the wattle, and according to the detail. Install a minimum of 2 stakes on the upstream side of the wattle according to the detail provided in the plans. Stakes shall be driven into the ground a minimum of 10 in. with no more than 2 in. projecting from the top of the wattle. Drive stakes at an angle according to the detail provided in the plans.

Only install wattle(s) to a height in ditch so flow will not wash around wattle and scour ditch slopes and according to the detail provided in the plans and as directed. Overlap adjoining sections of wattles a minimum of 6 in.

Installation of matting shall be in accordance with the detail provided in the plans, and in accordance with Article 1631-3 of the *Standard Specifications*, or in accordance with specifications provided elsewhere in this contract.

Apply PAM over the lower center portion of the wattle where the water is going to flow over at a rate of 2 ounces per wattle, and 1 ounce of PAM on matting on each side of the wattle. PAM applications shall be done during construction activities after every rainfall event that is equal to or exceeds 0.50 in.

The Contractor shall maintain the wattles until the project is accepted or until the wattles are removed, and shall remove and dispose of silt accumulations at the wattles when so directed in accordance with the requirements of Section 1630 of the *Standard Specifications*.

Measurement and Payment

Wattles will be measured and paid for by the actual number of linear feet of wattles which are installed and accepted. Such price and payment will be full compensation for all work covered by this section, including, but not limited to, furnishing all materials, labor, equipment and incidentals necessary to install the *Wattles*.

Matting will be measured and paid for in accordance with Article 1631-4 of the *Standard Specifications*, or in accordance with specifications provided elsewhere in this contract.

Polyacrylamide(PAM) will be measured and paid for by the actual weight in pounds of PAM applied to the wattles. Such price and payment will be full compensation for all work covered by this section, including, but not limited to, furnishing all materials, labor, equipment and incidentals necessary to apply the *Polyacrylamide(PAM)*.

Payment will be made under:

| Pay Item | Pay Unit |
|---------------------|-----------------|
| Polyacrylamide(PAM) | Pound |
| Wattle | Linear Foot |

SILT FENCE WATTLE BREAK:
 (8-21-12) 1605,1630

Description

Silt fence wattle breaks are tubular products consisting of excelsior fibers encased in synthetic netting and used in conjunction with temporary silt fence at [the](#) toe of fills to intercept runoff. Silt fence wattle breaks are to be placed at locations shown on the plans or as directed. Installation shall follow the detail provided in the plans and as directed. Work includes furnishing materials, installation, maintenance and removing silt fence wattle breaks.

Materials

Wattle shall meet the following specifications:

| | |
|-------------------------------------|-------------------------------|
| 100% Curled Wood (Excelsior) Fibers | |
| Minimum Diameter | 12" |
| Minimum Length | 10 ft |
| Minimum Density | 2.5 lb/cf ± 10% |
| Net Material | Synthetic |
| Net Openings | 1" x 1" |
| Net Configuration | Totally Encased |
| Minimum Weight | 20 lb. ± 10% per 10 ft length |

Stakes shall be used as anchors. Provide hardwood stakes a minimum of 2-ft long with a 2" x 2" nominal square cross section. One end of the stake shall be sharpened or beveled to facilitate driving down into the underlying soil.

Provide staples made of 0.125" diameter new steel wire formed into a U-shape not less than 12" in length with a throat of 1" in width.

Construction Methods

Excavate a trench the entire length of each wattle with a depth of 1" to 2" for the wattle to be placed. Secure silt fence wattle breaks to the soil by wire staples approximately every linear foot and at the end of each wattle. Install at least 4 stakes on the downslope side of the wattle with a maximum spacing of 2 linear feet; and according to the detail. Install at least 2 stakes on the upslope side of the silt fence wattle break according to the detail provided in the plans. Drive stakes into the ground at least 10" with no more than 2" projecting from the top of the wattle. Drive stakes at an angle according to the detail provided in the plans.

Install temporary silt fence in accordance with Section 1605 of the *2012 Standard Specifications* and overlap each downslope side of silt fence wattle break by 6".

Maintain the silt fence wattle breaks until the project is accepted or until the silt fence wattle breaks are removed, and remove and dispose of silt accumulations at the silt fence wattle breaks when so directed in accordance with Section 1630 of the *2012 Standard Specifications*.

Measurement and Payment

Wattle will be measured and paid as the actual number of linear feet of wattles installed and accepted. Such price and payment will be full compensation for all work covered by this provision, including, but not limited to, furnishing all materials, labor, equipment and incidentals necessary to install the silt fence wattle break.

Payment will be made under:

| Pay Item | Pay Unit |
|-----------------|-----------------|
| Wattle | Linear Foot |

COIR FIBER MAT:

Description

Furnish material, install and maintain coir fiber mat in locations shown on the plans or in locations as directed. Work includes providing all materials, excavating and backfilling, and placing and securing coir fiber mat with stakes, steel reinforcement bars or staples as directed.

Materials

| Item | Section |
|----------------|----------------|
| Coir Fiber Mat | 1060-14 |

Anchors: Stakes, reinforcement bars, or staples shall be used as anchors.

Wooden Stakes:

Provide hardwood stakes 12"- 24" long with a 2" x 2" nominal square cross section. One end of the stake must be sharpened or beveled to facilitate driving through the coir fiber mat and down into the underlying soil. The other end of the stake needs to have a 1"- 2" long head at the top with a 1"- 2" notch following to catch and secure the coir fiber mat.

Steel Reinforcement Bars:

Provide uncoated #10 steel reinforcement bars 24" nominal length. The bars shall have a 4" diameter bend at one end with a 4" straight section at the tip to catch and secure the coir fiber mat.

Staples:

Provide staples made of 0.125" diameter new steel wire formed into a *u* shape not less than 12" in length with a throat of 1" in width.

Construction Methods

Place the coir fiber mat immediately upon final grading. Provide a smooth soil surface free from stones, clods, or debris that will prevent the contact of the mat with the soil. Unroll the mat and apply without stretching such that it will lie smoothly but loosely on the soil surface.

For stream relocation applications, take care to preserve the required line, grade, and cross section of the area covered. Bury the top slope end of each piece of mat in a narrow trench at least 6 in. deep and tamp firmly. Where one roll of matting ends and a second roll begins, overlap the end of the upper roll over the buried end of the second roll so there is a 6 in. overlap. Construct check trenches at least 12 in. deep every 50 ft. longitudinally along the edges of the mat or as directed. Fold over and bury mat to the full depth of the trench, close and tamp firmly. Overlap mat at least 6 in. where 2 or more widths of mat are installed side by side.

Place anchors across the mat at the ends approximately 1 ft. apart. Place anchors along the outer edges and down the center of the mat 3 ft. apart.

Adjustments in the trenching or anchoring requirements to fit individual site conditions may be required.

Measurement and Payment

Coir Fiber Mat will be measured and paid for as the actual number of square yards measured along the surface of the ground over which coir fiber mat is installed and accepted.

No measurement will be made for anchor items.

Payment will be made under:

Pay Item

Coir Fiber Mat

Pay Unit

Square Yard

CONCRETE WASHOUT STRUCTURE:

(12-01-15)

Description

Concrete washout structures are enclosures above or below grade to contain concrete waste water and associated concrete mix from washing out ready-mix trucks, drums, pumps, or other equipment. Concrete washouts must collect and retain all the concrete washout water and solids, so that this material does not migrate to surface waters or into the ground water. These enclosures are not intended for concrete waste not associated with wash out operations.

The concrete washout structure may include constructed devices above or below ground and or commercially available devices designed specifically to capture concrete waste water.

Materials

Item

Temporary Silt Fence

Section

1605

Safety Fence shall meet the specifications as provided elsewhere in this contract.

Geomembrane basin liner shall meet the following minimum physical properties for low permeability; it shall consist of a polypropylene or polyethylene 10 mil thick geomembrane. If the minimum setback dimensions can be achieved the liner is not required. (5 feet above groundwater, 50 feet from top of bank of perennial stream, other surface water body, or wetland.)

Construction Methods

Build an enclosed earthen berm or excavate to form an enclosure in accordance with the details and as directed.

Install temporary silt fence around the perimeter of the enclosure in accordance with the details and as directed if structure is not located in an area where existing erosion and sedimentation control devices are capable to containing any loss of sediment.

Post a sign with the words "Concrete Washout" in close proximity of the concrete washout area, so it is clearly visible to site personnel.

The construction details for the above grade and below grade concrete washout structures can be found on the following web page link:

http://www.ncdot.gov/doh/operations/dp_chief_eng/roadside/soil_water/details/

Alternate details for accommodating concrete washout may be submitted for review and approval.

The alternate details shall include the method used to retain and dispose of the concrete waste water within the project limits and in accordance with the minimum setback requirements. (5 feet above groundwater, 50 feet from top of bank of perennial stream, other surface water body, or wetland.)

Maintenance and Removal

Maintain the concrete washout structure(s) to provide adequate holding capacity plus a minimum freeboard of 12 inches. Remove and dispose of hardened concrete and return the structure to a functional condition after reaching 75% capacity.

Inspect concrete washout structures for damage and maintain for effectiveness.

Remove the concrete washout structures and sign upon project completion. Grade the earth material to match the existing contours and permanently seed and mulch area.

Measurement and Payment

Concrete Washout Structure will be paid for per each enclosure installed in accordance with the details. If alternate details are approved then those details will also be paid for per each approved and installed device.

Temporary Silt Fence will be measured and paid for in accordance with Article 1605-5 of the *Standard Specifications*.

No measurement will be made for other items or for over excavation or stockpiling.

Payment will be made under:

| Pay Item | Pay Unit |
|----------------------------|-----------------|
| Concrete Washout Structure | Each |

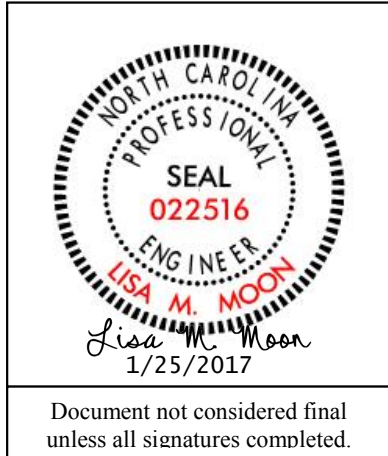

**Signals and Intelligent Transportation Systems
Project Special Provisions
(Version 12.5)**

*Prepared By: LMM
25-Jan-17*

Contents

1. 2012 STANDARD SPECIFICATIONS FOR ROADS & STRUCTURES.....3

1.1. POLYMER CONCRETE (PC) JUNCTION BOXES (1091-5(B)).....3

1.2. SUBMITTAL REQUIREMENTS (1098-1(B))3

1.3. JUNCTION BOXES (1098-5).....3

1.4. PEDESTALS (1098-14).....3

1.5. PEDESTALS (1743)4

1.6. CONTROLLERS WITH CABINETS (1751)6

2. SIGNAL HEADS.....6

2.1. MATERIALS6

A. *General:*.....6

B. *Vehicle Signal Heads:*.....8

C. *Pedestrian Signal Heads:*11

D. *Signal Cable:*.....12

3. CONTROLLERS WITH CABINETS13

3.1. MATERIALS – GENERAL CABINETS13

3.2. MATERIALS – TYPE 170E CABINETS14

A. *Type 170 E Cabinets General:*.....14

B. *Type 170 E Cabinet Electrical Requirements:*.....14

C. *Type 170 E Cabinet Physical Requirements:*.....22

D. *Model 2018 Enhanced Conflict Monitor:*24

3.3. MATERIALS – TYPE 170 DETECTOR SENSOR UNITS34

3.4. MATERIALS – TYPE 2070E CONTROLLERS34

3.5. MATERIALS – MODEL 2010ECLIP ENHANCED CONFLICT MONITOR35

4. ETHERNET EDGE SWITCH.....42

4.1. DESCRIPTION42

A. *Ethernet Edge Switch:*42

B. *Network Management:*.....42

4.2. MATERIALS42

A. *General:*.....42

B. *Standards:*.....43

C. *Functional:*43

D. *Physical Features:*44

E. *Management Capabilities:*44

F. *Electrical Specifications:*.....45

G. *Environmental Specifications:*45

H. *Ethernet Patch Cable:*46

4.3. CONSTRUCTION METHODS46

W-5520

TS-2

Union County

- A. *General*:..... 46
- B. *Edge Switch*:..... 47
- 4.4. MEASUREMENT AND PAYMENT 47
- 5. SPREAD SPECTRUM RADIO 47**
 - 5.1. DESCRIPTION 47
 - 5.2. MATERIAL 47
 - A. *General*..... 47
 - B. *900 MHz Serial/Ethernet Spread Spectrum Radio* 48
 - C. *Software*..... 49
 - D. *Ethernet Patch Cable for Ethernet Communications*: 50
 - E. *Directional Antenna (Yagi)*..... 50
 - F. *Antenna Mounting Hardware Kit* 51
 - G. *Coaxial Cable*..... 52
 - H. *Standard N-Type Male Connector* 52
 - I. *Coaxial Cable Shield Grounding and Weatherproofing Kits* 53
 - J. *Lightning Arrestor* 53
 - K. *Coaxial Cable – Power Divider (Splitter)* 54
 - L. *Disconnect Switch*..... 54
 - M. *Warning Signs and Decal* 54
 - 5.3. CONSTRUCTION METHODS 54
 - A. *General*..... 54
 - B. *Disconnect Switch*..... 55
 - C. *Warning Sign(s) and Decal(s)* 55
 - 5.4. MEASUREMENT AND PAYMENT 56

1. 2012 STANDARD SPECIFICATIONS FOR ROADS & STRUCTURES

The 2012 Standard Specifications are revised as follows:

1.1. Polymer Concrete (PC) Junction Boxes (1091-5(B))

Page 10-202, revise paragraph starting on line 9 to read “Provide polymer concrete (PC) boxes which have bolted covers and open bottoms. Provide vertical extensions of 6" to 12" as required by project special provisions.”

Page 10-202, revise sentence beginning on line 14 to read “Other thermoplastic materials may be used for components which are not normally exposed to sunlight.”

1.2. Submittal Requirements (1098-1(B))

Page 10-208, replace paragraph on line 34 with the following:

Submit for approval catalog cuts and/or shop drawings for materials proposed for use on the project. Allow 40 days for review of each submittal. Do not fabricate or order material until receipt of Engineer’s approval.

Submit 4 copies of each catalog cut and/or drawing and show for each component the material description, brand name, stock-number, size, rating, manufacturing specification and the intended use (identified by labeling all components with the corresponding contract line item number). Present the submittals neatly arranged in the same order as the contract bid items. Electronic submittals of catalog cuts and drawings may be accepted in lieu of hard copies.

One hard copy and an electronic (PDF) copy of reviewed submittals will be returned to the Engineer from the ITS and Signals Unit.

1.3. Junction Boxes (1098-5)

Page 10-212, sub-Section 1098-5(C) Oversized Junction Boxes

Revise sentence to read, “Provide oversized junction boxes and covers with minimum inside dimensions of 28"(l) x 15"(w) x 22"(h).”

1.4. Pedestals (1098-14)

Page 10-218, sub-Section 1098-14(A) Pedestal Shaft

Replace “6063-T6” with “6061-T6” in the second paragraph on line 24.

Page 10-219, sub-Section 1098-14(B) Transformer Bases

Revise paragraph 2, lines 19 to 21 to read: “Provide a minimum access opening for all transformer bases of 8”x 8” with an access door that is attached with a 1/4” x 3/4” long stainless steel vandal proof screw to secure access door.”

Add the following sentence after the second sentence of paragraph 3 on line 24: “Include a set screw prep and 3/8”-16 x 1” stainless steel set screw to secure the pedestal post to the pedestal base.”

Page 10-219-220, sub-Section 1098-14 (C) Anchor Bolts

Replace entire paragraph on page 219, line 45-49 and page 220, line 1-5 with the following paragraphs:

For each pedestal, provide four (4) anchor bolts meeting the requirements of ASTM F1554, Grade 55, of the size and length specified in *Roadway Standard Drawings* No. 1743. Provide anchor

W-5520**TS-4****Union County**

bolts with coarse threads meeting the bolt/thread criteria specified by AISC. Provide threads for a minimum length of 4" on each end of the bolt. All thread anchor rods may be used. Ensure anchor bolts are hot-dipped galvanized in accordance with ASTM A153.

For each anchor bolt:

- Provide three (3) heavy hex nuts; one at the top, and 2 at the bottom (embedded end) of the anchor bolt. Provide hex nuts with coarse threads that match the anchor bolt thread requirements above. Provide hex nuts that meet the requirements of ASTM A563 Grade DH, ASTM A194, Grade 2H or equivalent. Galvanize all heavy hex nuts in accordance with ASTM A153.
- Provide one (1) standard size washer that meets the requirements of ASTM F436 for use between the two heavy hex nuts on the embedded end of the anchor bolt. Galvanize in accordance with ASTM A153.
- Provide one (1) extra thick, oversized washer for use over the slotted opening of the pedestal base. Fabricate washer to meet the chemical, physical, and heat treating requirements of ASTM F436. Fabricate the washer to the diameter and thickness needed. Galvanize fabricated washer in accordance with ASTM A153. Heat treat to the same requirements as F436 (i.e. 26 to 45 HRC).

For a ¾" diameter anchor bolt mounted in a 1 ½" slotted opening, the dimensional requirements for an extra thick, oversized washer are as follows:

- The minimum Outside Diameter (OD) required is 2 ¾".
- The hole Inside Diameter (ID) = Nominal Bolt Diameter + 1/16" = 0.812".
- The minimum washer thickness required is 3/8".

If anchor bolts less than ¾" in diameter are proposed for use to anchor pedestal bases, provide a washer calculation to ensure the washer thickness is adequate. To account for any pedestal manufacturing differences, verify the actual slotted opening width of the pedestal base anchoring points, and include it in the calculation. Anchor bolts that are less than ½" in diameter may not be used as they are not structurally adequate to support the pedestal and may inhibit the performance of the breakaway base.

The fabrication process for thick washers makes the washer slightly tapered (i.e. the top OD and the bottom OD are not the same). Install thick washers with the larger diameter face down against the pedestal base casting.

Do not use standard washers over the slotted opening of the pedestal base. Do not substitute or stack thin washers to achieve the required thickness specified or required.

In addition to the submittal requirements of Section 1098-1(B), provide Mill Certifications, Galvanization Certifications, and Heat Treating Certifications for all anchor bolts, fabricated washers, and structural hardware.

1.5. Pedestals (1743)

Page 17-34, Add the following new sub-Section:

1743-4 - Screw-In Helical Foundation Anchor Assembly

Description:

Furnish and install screw-in helical foundation as an alternative to the standard reinforced concrete foundation specified in Article 1743 "Pedestals" of the Standard Specifications, for supporting Type I and Type II Pedestals. Do not use for Type III Pedestals.

Materials for Type I – Pedestrian Pushbutton Post:

Fabricate pipe assembly consisting of a 4" diameter x 56" long pipe, single helical blade and square fixed attachment plate. Furnish pipe in accordance with ASTM A-53 ERW Grade B and include a 2" x 3" cable opening in the pipe at 18" below the attachment plate. Furnish steel attachment plate and helical blade in accordance with ASTM A-36. Include (4) slotted mounting holes in the attachment plate to fit bolt circles ranging from 7-3/4" to 14-3/4" diameter. Furnish additional 3/4" keyholes at slotted holes to permit anchor bolt installation and replacement from top surface. Include combination bolt-head retainer and dirt scrapers at the attachment plate underside to allow for a level or flush-mount plate installation with respect to the finished grade. Galvanize pipe assembly components in accordance with AASHTO M 111 or an approved equivalent.

Furnish (4) 3/4"-10NC x 3" square head anchor bolts to meet the requirements of ASTM 325. Provide (4) 3/4" plain flat galvanized washers, (4) 3/16" thick galvanized plate washers and (4) 3/4" galvanized hex nuts. Galvanize in accordance with AASHTO M 111 or an approved equivalent.

Construction Methods for Type I – Pedestrian Pushbutton Post:

Advance or mechanically screw foundation into soil up until top of attachment plate is level with finished grade. Slide the anchor bolt heads through the keyhole openings and under the attachment plate with threads pointing up. Bolt the pedestal base to the foundation attachment plate. For further construction methods, see manufacturer's installation drawings.

Materials for Type II – Normal-Duty Pedestal:

Fabricate pipe assembly consisting of a 6" diameter x 60" long, single helical blade, 1-1/4" diameter stinger rod and square fixed attachment plate. Furnish pipe in accordance with ASTM A-53 ERW Grade B using schedule 40 wall thickness and include a 2" x 3" cable opening in the pipe at 18" below the attachment plate. Furnish steel attachment plate, helical blade and stinger rod in accordance with ASTM A-36. Include (4) slotted mounting holes in the attachment plate to fit bolt circles ranging from 10" to 15" diameter. Furnish additional 1-1/4" keyholes at slotted holes to permit anchor bolt installation and replacement from top surface. Include combination bolt-head retainer and dirt scrapers at the attachment plate underside to allow for a level or flush-mount plate installation with respect to the finished grade. Galvanize pipe assembly components in accordance with AASHTO M 111 or an approved equivalent.

Furnish (4) 1"-8NC x 4" galvanized Grade 5 square head anchor bolts. Provide (4) 1" plain flat galvanized washers and (4) 1" galvanized hex nuts. Galvanize in accordance with AASHTO M 111 or an approved equivalent.

Construction Methods for Type II – Normal-Duty Pedestal:

Advance or mechanically screw foundation into soil up until top of attachment plate is level with finished grade. Slide the anchor bolt heads through the keyhole openings and under the attachment plate with threads pointing up. Bolt the pedestal base to the foundation attachment plate.

For further construction methods, see manufacturer's installation drawings.

Page 17-34, revise Measurement and Payment to sub-Section 1743-5.

Revise the last paragraph to read:

No measurement will be made for pedestal foundations, pedestal screw-in helical foundations, grounding systems and any peripheral pedestal mounting hardware as these are incidental to furnishing and installing pedestals.

1.6. Controllers with Cabinets (1751)

Page 17-37, Add the following paragraphs to 1751-1:

Replace signal controllers and conflict monitors in existing cabinets as directed in the Plans.

Page 17-38, Add the following after third paragraph to 1751-4:

Replace controller will be measured and paid as the actual number of 2070E replacement controllers furnished, installed, and accepted in existing cabinets.

Replace Conflict Monitor will be measured and paid as the actual number of replacement 2010 ECLip enhanced conflict monitors furnished, installed, and accepted in existing cabinets.

Page 17-38, Add the following pay items to 1751-4:

| | |
|--------------------------------|------|
| Replace Controller | Each |
| Replace Conflict Monitor | Each |

2. SIGNAL HEADS

2.1. MATERIALS

A. General:

Fabricate vehicle signal head housings and end caps from die-cast aluminum. Fabricate 12-inch and 16-inch pedestrian signal head housings and end caps from die-cast aluminum. Fabricate 9-inch pedestrian signal head housings, end caps, and visors from virgin polycarbonate material. Provide visor mounting screws, door latches, and hinge pins fabricated from stainless steel. Provide interior screws, fasteners, and metal parts fabricated from stainless steel.

Fabricate tunnel and traditional visors from sheet aluminum.

Paint all surfaces inside and outside of signal housings and doors. Paint outside surfaces of tunnel and traditional visors, wire outlet bodies, wire entrance fitting brackets and end caps when supplied as components of messenger cable mounting assemblies, pole and pedestal mounting assemblies, and pedestrian pushbutton housings. Have electrostatically-applied, fused-polyester paint in highway yellow (Federal Standard 595C, Color Chip Number 13538) a minimum of 2.5 to 3.5 mils thick. Do not apply paint to the latching hardware, rigid vehicle signal head mounting brackets for mast-arm attachments, messenger cable hanger components or balance adjuster components.

Have the interior surfaces of tunnel and traditional visors painted an alkyd urea black synthetic baking enamel with a minimum gloss reflectance and meeting the requirements of MIL-E-10169, "Enamel Heat Resisting, Instrument Black."

Where required, provide polycarbonate signal heads and visors that comply with the provisions pertaining to the aluminum signal heads listed on the QPL with the following exceptions:

Fabricate signal head housings, end caps, and visors from virgin polycarbonate material. Provide UV stabilized polycarbonate plastic with a minimum thickness of 0.1 ± 0.01 inches that is highway yellow (Federal Standard 595C, Color Chip 13538). Ensure the color is incorporated into the plastic material before molding the signal head housings and end caps. Ensure the plastic

W-5520**TS-7****Union County**

formulation provides the following physical properties in the assembly (tests may be performed on separately molded specimens):

| Test | Required | Method |
|----------------------------------------------------|--------------------|---------------|
| Specific Gravity | 1.17 minimum | ASTM D 792 |
| Flammability | Self-extinguishing | ASTM D 635 |
| Tensile Strength, yield, PSI | 8500 minimum | ASTM D 638 |
| Izod impact strength, ft-lb/in [notched, 1/8 inch] | 12 minimum | ASTM D 256 |

For pole mounting, provide side of pole mounting assemblies with framework and all other hardware necessary to make complete, watertight connections of the signal heads to the poles and pedestals. Fabricate the mounting assemblies and frames from aluminum with all necessary hardware, screws, washers, etc. to be stainless steel. Provide mounting fittings that match the positive locking device on the signal head with the serrations integrally cast into the brackets. Provide upper and lower pole plates that have a 1 ¼-inch vertical conduit entrance hubs with the hubs capped on the lower plate and 1 ½-inch horizontal hubs. Ensure that the assemblies provide rigid attachments to poles and pedestals so as to allow no twisting or swaying of the signal heads. Ensure that all raceways are free of sharp edges and protrusions, and can accommodate a minimum of ten Number 14 AWG conductors.

For pedestal mounting, provide a post-top slipfitter mounting assembly that matches the positive locking device on the signal head with serrations integrally cast into the slipfitter. Provide stainless steel hardware, screws, washers, etc. Provide a minimum of six 3/8 X 3/4-inch long square head bolts for attachment to pedestal. Provide a center post for multi-way slipfitters.

For light emitting diode (LED) traffic signal modules, provide the following requirements for inclusion on the Department's Qualified Products List for traffic signal equipment.

1. Sample submittal,
2. Third-party independent laboratory testing results for each submitted module with evidence of testing and conformance with all of the Design Qualification Testing specified in section 6.4 of each of the following Institute of Transportation Engineers (ITE) specifications:
 - Vehicle Traffic Control Signal Heads – Light Emitting Diode (LED) Circular Signal Supplement
 - Vehicle Traffic Control Signal Heads – Light Emitting Diode (LED) Vehicle Arrow Traffic Signal Supplement
 - Pedestrian Traffic Control Signal Indications –Light Emitting Diode (LED) Signal Modules.

(Note: The Department currently recognizes two approved independent testing laboratories. They are Intertek ETL Semko and Light Metrics, Incorporated with Garwood Laboratories. Independent laboratory tests from other laboratories may be considered as part of the QPL submittal at the discretion of the Department,

3. Evidence of conformance with the requirements of these specifications,
4. A manufacturer's warranty statement in accordance with the required warranty, and

W-5520**TS-8****Union County**

5. Submittal of manufacturer's design and production documentation for the model, including but not limited to, electrical schematics, electronic component values, proprietary part numbers, bill of materials, and production electrical and photometric test parameters.
6. Evidence of approval of the product to bear the Intertek ETL Verified product label for LED traffic signal modules.

In addition to meeting the performance requirements for the minimum period of 60 months, provide a written warranty against defects in materials and workmanship for the modules for a period of 60 months after installation of the modules. During the warranty period, the manufacturer must provide new replacement modules within 45 days of receipt of modules that have failed at no cost to the State. Repaired or refurbished modules may not be used to fulfill the manufacturer's warranty obligations. Provide manufacturer's warranty documentation to the Department during evaluation of product for inclusion on Qualified Products List (QPL).

B. Vehicle Signal Heads:

Comply with the ITE standard "Vehicle Traffic Control Signal Heads". Provide housings with provisions for attaching backplates.

Provide visors that are 8 inches in length for 8-inch vehicle signal head sections. Provide visors that are 10 inches in length for 12-inch vehicle signal heads.

Provide a termination block with one empty terminal for field wiring for each indication plus one empty terminal for the neutral conductor. Have all signal sections wired to the termination block. Provide barriers between the terminals that have terminal screws with a minimum Number 8 thread size and that will accommodate and secure spade lugs sized for a Number 10 terminal screw.

Mount termination blocks in the yellow signal head sections on all in-line vehicle signal heads. Mount the termination block in the red section on five-section vehicle signal heads.

Furnish vehicle signal head interconnecting brackets. Provide one-piece aluminum brackets less than 4.5 inches in height and with no threaded pipe connections. Provide hand holes on the bottom of the brackets to aid in installing wires to the signal heads. Lower brackets that carry no wires and are used only for connecting the bottom signal sections together may be flat in construction.

For messenger cable mounting, provide messenger cable hangers, wire outlet bodies, balance adjusters, bottom caps, wire entrance fitting brackets, and all other hardware necessary to make complete, watertight connections of the vehicle signal heads to the messenger cable. Fabricate messenger cable hanger components, wire outlet bodies and balance adjuster components from stainless steel or malleable iron galvanized in accordance with ASTM A153 (Class A) or ASTM A123. Provide serrated rings made of aluminum. Provide messenger cable hangers with U-bolt clamps. Fabricate washers, screws, hex-head bolts and associated nuts, clevis pins, cotter pins, U-bolt clamps and nuts from stainless steel.

For mast-arm mounting, provide rigid vehicle signal head mounting brackets and all other hardware necessary to make complete, watertight connections of the vehicle signal heads to the mast arms and to provide a means for vertically adjusting the vehicle signal heads to proper alignment. Fabricate the mounting assemblies from aluminum, and provide serrated rings made of aluminum. Provide stainless steel cable attachment assemblies to secure the brackets to the mast arms. Ensure all fastening hardware and fasteners are fabricated from stainless steel.

W-5520**TS-9****Union County**

Provide LED vehicular traffic signal modules (hereafter referred to as modules) that consist of an assembly that uses LEDs as the light source in lieu of an incandescent lamp for use in traffic signal sections. Use LEDs that are aluminum indium gallium phosphorus (AlInGaP) technology for red and yellow indications and indium gallium nitride (InGaN) for green indications. Install the ultra bright type LEDs that are rated for 100,000 hours of continuous operation from -40°F to +165°F. Design modules to have a minimum useful life of 60 months and to meet all parameters of this specification during this period of useful life.

For the modules, provide spade terminals crimped to the lead wires and sized for a #10 screw connection to the existing terminal block in a standard signal head. Do not provide other types of crimped terminals with a spade adapter.

Ensure the power supply is integral to the module assembly. On the back of the module, permanently mark the date of manufacture (month & year) or some other method of identifying date of manufacture.

Tint the red, yellow and green lenses to correspond with the wavelength (chromaticity) of the LED. Transparent tinting films are unacceptable. Provide a lens that is integral to the unit with a smooth outer surface.

1. LED Circular Signal Modules:

Provide modules in the following configurations: 12-inch circular sections, and 8-inch circular sections. All makes and models of LED modules purchased for use on the State Highway System shall appear on the current NCDOT Traffic Signal Qualified Products List (QPL).

Provide the manufacturer's model number and the product number (assigned by the Department) for each module that appears on the 2012 or most recent Qualified Products List. In addition, provide manufacturer's certification in accordance with Article 106-3 of the *Standard Specifications*, that each module meets or exceeds the ITE "Vehicle Traffic Control Signal Heads – Light Emitting Diode (LED) Circular Signal Supplement" dated June 27, 2005 (hereafter referred to as VTCSH Circular Supplement) and other requirements stated in this specification.

Provide modules that meet the following requirements when tested under the procedures outlined in the VTCSH Circular Supplement:

| Module Type | Max. Wattage at 165° F | Nominal Wattage at 77° F |
|------------------------|------------------------|--------------------------|
| 12-inch red circular | 17 | 11 |
| 8-inch red circular | 13 | 8 |
| 12-inch green circular | 15 | 15 |
| 8-inch green circular | 12 | 12 |

For yellow circular signal modules, provide modules tested under the procedures outlined in the VTCSH Circular Supplement to insure power required at 77° F is 22 Watts or less for the 12-inch circular module and 13 Watts or less for the 8-inch circular module.

Note: Use a wattmeter having an accuracy of $\pm 1\%$ to measure the nominal wattage and maximum wattage of a circular traffic signal module. Power may also be derived from voltage, current and power factor measurements.

W-5520**TS-10****Union County****2. LED Arrow Signal Modules**

Provide 12-inch omnidirectional arrow signal modules. All makes and models of LED modules purchased for use on the State Highway System shall appear on the current NCDOT Traffic Signal Qualified Products List (QPL).

Provide the manufacturer's model number and the product number (assigned by the Department) for each module that appears on the 2012 or most recent Qualified Products List. In addition, provide manufacturer's certification in accordance with Article 106-3 of the *Standard Specifications*, that each module meets or exceeds the requirements for 12-inch omnidirectional modules specified in the ITE "Vehicle Traffic Control Signal Heads – Light Emitting Diode (LED) Vehicle Arrow Traffic Signal Supplement" dated July 1, 2007 (hereafter referred to as VTCSH Arrow Supplement) and other requirements stated in this specification.

Provide modules that meet the following requirements when tested under the procedures outlined in the VTCSH Arrow Supplement:

| Module Type | Max. Wattage at 165° F | Nominal Wattage at 77° F |
|---------------------|------------------------|--------------------------|
| 12-inch red arrow | 12 | 9 |
| 12-inch green arrow | 11 | 11 |

For yellow arrow signal modules, provide modules tested under the procedures outlined in the VTCSH Arrow Supplement to insure power required at 77° F is 12 Watts or less.

Note: Use a wattmeter having an accuracy of $\pm 1\%$ to measure the nominal wattage and maximum wattage of an arrow traffic signal module. Power may also be derived from voltage, current and power factor measurements.

3. LED U-Turn Arrow Signal Modules:

Provide modules in the following configurations: 12-inch left u-turn arrow signal modules and 12-inch right u-turn arrow signal modules.

Modules are not required to be listed on the ITS and Signals Qualified Products List. Provide manufacturer's certification in accordance with Article 106-3 of the *Standard Specifications*, that each module meets or exceeds the ITE "Vehicle Traffic Control Signal Heads – Light Emitting Diode (LED) Circular Signal Supplement" dated June 27, 2005 (hereafter referred to as VTCSH Circular Supplement) and other requirements stated in this specification.

Provide modules that have minimum maintained luminous intensity values that are not less than 16% of the values calculated using the method described in section 4.1 of the VTCSH Circular Supplement.

Provide modules that meet the following requirements when tested under the procedures outlined in the VTCSH Circular Supplement:

| Module Type | Max. Wattage at 165° F | Nominal Wattage at 77° F |
|----------------------------|------------------------|--------------------------|
| 12-inch red u-turn arrow | 17 | 11 |
| 12-inch green u-turn arrow | 15 | 15 |

For yellow u-turn arrow signal modules, provide modules tested under the procedures outlined in the VTCSH Circular Supplement to ensure power required at 77° F is 22 Watts or less.

Note: Use a wattmeter having an accuracy of $\pm 1\%$ to measure the nominal wattage and maximum wattage of a circular traffic signal module. Power may also be derived from voltage, current and power factor measurements.

C. Pedestrian Signal Heads:

Provide pedestrian signal heads with international symbols that meet the MUTCD. Do not provide letter indications.

Comply with the ITE standard for "Pedestrian Traffic Control Signal Indications" and the following sections of the ITE standard for "Vehicle Traffic Control Signal Heads" in effect on the date of advertisement:

- Section 3.00 - "Physical and Mechanical Requirements"
- Section 4.01 - "Housing, Door, and Visor: General"
- Section 4.04 - "Housing, Door, and Visor: Materials and Fabrication"
- Section 7.00 - "Exterior Finish"

Provide a double-row termination block with three empty terminals and number 10 screws for field wiring. Provide barriers between the terminals that accommodate a spade lug sized for number 10 terminal screws. Mount the termination block in the hand section. Wire all signal sections to the terminal block.

Where required by the plans, provide 16-inch pedestrian signal heads with traditional three-sided, rectangular visors, 6 inches long. Where required by the plans, provide 12-inch pedestrian signal heads with traditional three-sided, rectangular visors, 8 inches long.

Provide 2-inch diameter pedestrian push-buttons with weather-tight housings fabricated from die-cast aluminum and threading in compliance with the NEC for rigid metal conduit. Provide a weep hole in the housing bottom and ensure that the unit is vandal resistant.

Provide push-button housings that are suitable for mounting on flat or curved surfaces and that will accept 1/2-inch conduit installed in the top. Provide units that have a heavy duty push-button assembly with a sturdy, momentary, normally-open switch. Have contacts that are electrically insulated from the housing and push-button. Ensure that the push-buttons are rated for a minimum of 5 mA at 24 volts DC and 250 mA at 12 volts AC.

Provide standard R10-3 signs with mounting hardware that comply with the MUTCD in effect on the date of advertisement. Provide R10-3E signs for countdown pedestrian heads and R10-3B for non-countdown pedestrian heads.

Design the LED pedestrian traffic signal modules (hereafter referred to as modules) for installation into standard pedestrian traffic signal sections that do not contain the incandescent signal section reflector, lens, eggcrate visor, gasket, or socket. Provide modules that consist of an assembly that uses LEDs as the light source in lieu of an incandescent lamp. Use LEDs that are of the latest aluminum indium gallium phosphorus (AlInGaP) technology for the Portland Orange hand and countdown displays. Use LEDs that are of the latest indium gallium nitride (InGaN) technology for the Lunar White walking man displays. Install the ultra-bright type LEDs that are rated for 100,000 hours of continuous operation from -40°F to $+165^{\circ}\text{F}$. Design modules to have a minimum useful life of 60 months and to meet all parameters of this specification during this period of useful life.

W-5520**TS-12****Union County**

Design all modules to operate using a standard 3 - wire field installation. Provide spade terminals crimped to the lead wires and sized for a #10 screw connection to the existing terminal block in a standard pedestrian signal housing. Do not provide other types of crimped terminals with a spade adapter.

Ensure the power supply is integral to the module assembly. On the back of the module, permanently mark the date of manufacture (month & year) or some other method of identifying date of manufacture.

Provide modules in the following configuration: 16-inch displays which have the solid hand/walking man overlay on the left and the countdown on the right, and 12-inch displays which have the solid hand/walking man module as an overlay. All makes and models of LED modules purchased for use on the State Highway System shall appear on the current NCDOT Traffic Signal Qualified Products List (QPL).

Provide the manufacturer's model number and the product number (assigned by the Department) for each module that appears on the 2012 or most recent Qualified Products List. In addition, provide manufacturer's certification in accordance with Article 106-3 of the *Standard Specifications*, that each module meets or exceeds the ITE "Pedestrian Traffic Control Signal Indicators - Light Emitting Diode (LED) Signal Modules" dated August 04, 2010 (hereafter referred to as PTCSI Pedestrian Standard) and other requirements stated in this specification.

Provide modules that meet the following requirements when tested under the procedures outlined in the PTCSI Pedestrian Standard:

| Module Type | Max. Wattage at 165° F | Nominal Wattage at 77° F |
|------------------------|------------------------|--------------------------|
| Hand Indication | 16 | 13 |
| Walking Man Indication | 12 | 9 |
| Countdown Indication | 16 | 13 |

Note: Use a wattmeter having an accuracy of $\pm 1\%$ to measure the nominal wattage and maximum wattage of a circular traffic signal module. Power may also be derived from voltage, current and power factor measurements.

Provide module lens that is hard coated or otherwise made to comply with the material exposure and weathering effects requirements of the Society of Automotive Engineers (SAE) J576. Ensure all exposed components of the module are suitable for prolonged exposure to the environment, without appreciable degradation that would interfere with function or appearance.

Ensure the countdown display continuously monitors the traffic controller to automatically learn the pedestrian phase time and update for subsequent changes to the pedestrian phase time.

Ensure the countdown display begins normal operation upon the completion of the preemption sequence and no more than one pedestrian clearance cycle.

D. Signal Cable:

Furnish 16-4 and 16-7 signal cable that complies with IMSA specification 20-1 except provide the following conductor insulation colors:

- For 16-4 cable: white, yellow, red, and green

W-5520**TS-13****Union County**

- For 16-7 cable: white, yellow, red, green, yellow with black stripe tracer, red with black stripe tracer, and green with black stripe tracer. Apply continuous stripe tracer on conductor insulation with a longitudinal or spiral pattern.

Provide a ripcord to allow the cable jacket to be opened without using a cutter. IMSA specification 19-1 will not be acceptable. Provide a cable jacket labeled with the IMSA specification number and provide conductors constructed of stranded copper.

3. CONTROLLERS WITH CABINETS

3.1. MATERIALS – GENERAL CABINETS

Provide a moisture resistant coating on all circuit boards.

Provide one 20 mm diameter radial lead UL-recognized metal oxide varistor (MOV) between each load switch field terminal and equipment ground. Electrical performance is outlined below.

| PROPERTIES OF MOV SURGE PROTECTOR | |
|----------------------------------------------|--------------------------|
| Maximum Continuous Applied Voltage at 185° F | 150 VAC (RMS) 200 VDC |
| Maximum Peak 8x20µs Current at 185° F | 6500 A |
| Maximum Energy Rating at 185° F | 80 J |
| Voltage Range 1 mA DC Test at 77° F | 212-268 V |
| Max. Clamping Voltage 8x20µs, 100A at 77° F | 395 V |
| Typical Capacitance (1 MHz) at 77° F | 1600 pF |

Provide a power line surge protector that is a two-stage device that will allow connection of the radio frequency interference filter between the stages of the device. Ensure that a maximum continuous current is at least 10A at 120V. Ensure that the device can withstand a minimum of 20 peak surge current occurrences at 20,000A for an 8x20 microsecond waveform. Provide a maximum clamp voltage of 395V at 20,000A with a nominal series inductance of 200µh. Ensure that the voltage does not exceed 395V. Provide devices that comply with the following:

| Frequency (Hz) | Minimum Insertion Loss (dB) |
|----------------|-----------------------------|
| 60 | 0 |
| 10,000 | 30 |
| 50,000 | 55 |
| 100,000 | 50 |
| 500,000 | 50 |
| 2,000,000 | 60 |
| 5,000,000 | 40 |
| 10,000,000 | 20 |
| 20,000,000 | 25 |

3.2. MATERIALS – TYPE 170E CABINETS

A. Type 170 E Cabinets General:

Conform to the city of Los Angeles' Specification No. 54-053-08, *Traffic Signal Cabinet Assembly Specification* (dated July 2008), except as required herein.

Furnish model 336S pole mounted cabinets configured for 8 vehicle phases, 4 pedestrian phases, and 6 overlaps. Do not reassign load switches to accommodate overlaps unless shown on electrical details. Provide 336S pole mounted cabinets that are 46" high with 40" high internal rack assemblies.

Furnish model 332 base mounted cabinets configured for 8 vehicle phases, 4 pedestrian phases, and 6 overlaps. When overlaps are required, provide auxiliary output files for the overlaps. Do not reassign load switches to accommodate overlaps unless shown on electrical details.

Provide model 200 load switches, model 222 loop detector sensors, model 252 AC isolators, and model 242 DC isolators according to the electrical details. As a minimum, provide one (1) model 2018 conflict monitor, one (1) model 206L power supply unit, two (2) model 204 flashers, one (1) DC isolator (located in slot I14), and four (4) model 430 flash transfer relays (provide seven (7) model 430 flash transfer relays if auxiliary output file is installed) with each cabinet.

B. Type 170 E Cabinet Electrical Requirements:

Provide a cabinet assembly designed to ensure that upon leaving any cabinet switch or conflict monitor initiated flashing operation, the controller starts up in the programmed start up phases and start up interval.

Furnish two sets of non-fading cabinet wiring diagrams and schematics in a paper envelope or container and placed in the cabinet drawer.

All AC+ power is subject to radio frequency signal suppression.

Provide surge suppression in the cabinet for each type of cabinet device. Provide surge protection for the full capacity of the cabinet input file. Provide surge suppression devices that

W-5520**TS-15****Union County**

operate properly over a temperature range of -40° F to +185° F. Ensure the surge suppression devices provide both common and differential modes of protection.

Provide a pluggable power line surge protector that is installed on the back of the PDA (power distribution assembly) chassis to filter and absorb power line noise and switching transients. Ensure the device incorporates LEDs for failure indication and provides a dry relay contact closure for the purpose of remote sensing. Ensure the device meets the following specifications:

| | |
|------------------------------------------------|----------------------|
| Peak Surge Current (Single pulse, 8x20µs)..... | 20,000A |
| Occurrences (8x20µs waveform)..... | 10 minimum @ 20,000A |
| Maximum Clamp Voltage..... | 395VAC |
| Operating Current..... | 15 amps |
| Response Time..... | < 5 nanoseconds |

Provide a loop surge suppressor for each set of loop terminals in the cabinet. Ensure the device meets the following specifications:

| | |
|--------------------------------------|-----------------|
| Peak Surge Current (6 times, 8x20µs) | |
| (Differential Mode)..... | 400A |
| (Common Mode)..... | 1,000A |
| Occurrences (8x20µs waveform)..... | 500 min @ 200A |
| Maximum Clamp Voltage | |
| (Differential Mode @400A)..... | 35V |
| (Common Mode @1,000A)..... | 35V |
| Response Time..... | < 5 nanoseconds |
| Maximum Capacitance..... | 35 pF |

Provide a data communications surge suppressor for each communications line entering or leaving the cabinet. Ensure the device meets the following specifications:

| | |
|------------------------------------------------|-------------------------------|
| Peak Surge Current (Single pulse, 8x20µs)..... | 10,000A |
| Occurrences (8x20µs waveform)..... | 100 min @ 2,000A |
| Maximum Clamp Voltage..... | Rated for equipment protected |
| Response Time..... | < 1 nanosecond |
| Maximum Capacitance..... | 1,500 pF |
| Maximum Series Resistance..... | 15Ω |

W-5520**TS-16****Union County**

Provide a DC signal surge suppressor for each DC input channel in the cabinet. Ensure the device meets the following specifications:

Peak Surge Current (Single pulse, 8x20 μ s).....10,000A
 Occurrences (8x20 μ s waveform).....100 @ 2,000A
 Maximum Clamp Voltage.....30V
 Response Time.....< 1 nanosecond

Provide a 120 VAC signal surge suppressor for each AC+ interconnect signal input. Ensure the device meets the following specifications:

Peak Surge Current (Single pulse, 8x20 μ s).....20,000A
 Maximum Clamp Voltage.....350VAC
 Response Time.....< 200 nanoseconds
 Discharge Voltage.....<200 Volts @ 1,000A
 Insulation Resistance..... \geq 100 M Ω

Provide conductors for surge protection wiring that are of sufficient size (ampacity) to withstand maximum overcurrents which could occur before protective device thresholds are attained and current flow is interrupted.

If additional surge protected power outlets are needed to accommodate fiber transceivers, modems, etc., install a UL listed, industrial, heavy-duty type power outlet strip with a minimum rating of 15 A / 125 VAC, 60 Hz. Provide a strip that has a minimum of 3 grounded outlets. Ensure the power outlet strip plugs into one of the controller unit receptacles located on the rear of the PDA. Ensure power outlet strip is mounted securely; provide strain relief if necessary.

Provide a door switch in the front and a door switch in the rear of the cabinet that will provide the controller unit with a Door Ajar alarm when either the front or the rear door is open. Ensure the door switches apply DC ground to the Input File when either the front door or the rear door is open.

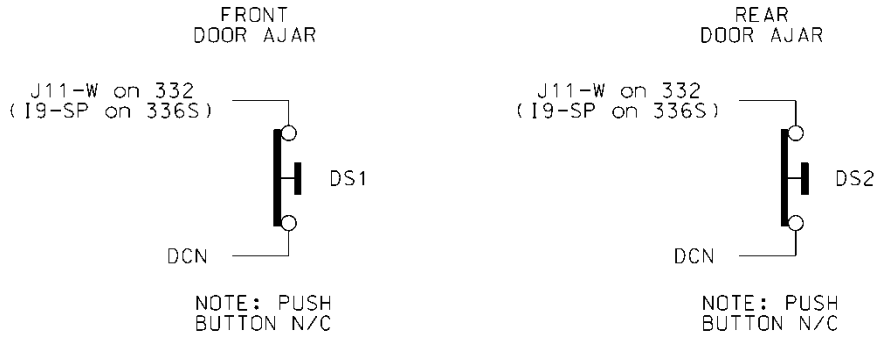

Furnish a fluorescent fixture in the rear across the top of the cabinet and another fluorescent fixture in the front across the top of the cabinet at a minimum. Ensure that the fixtures provide sufficient light to illuminate all terminals, labels, switches, and devices in the cabinet. Conveniently locate the fixtures so as not to interfere with a technician's ability to perform work on any devices or terminals in the cabinet. Provide a protective diffuser to cover exposed bulbs. Install 16 watt T-4 lamps in the fluorescent fixtures. Provide a door switch to provide power to each fixture when the respective door is open. Wire the fluorescent fixtures to the 15 amp ECB (equipment circuit breaker).

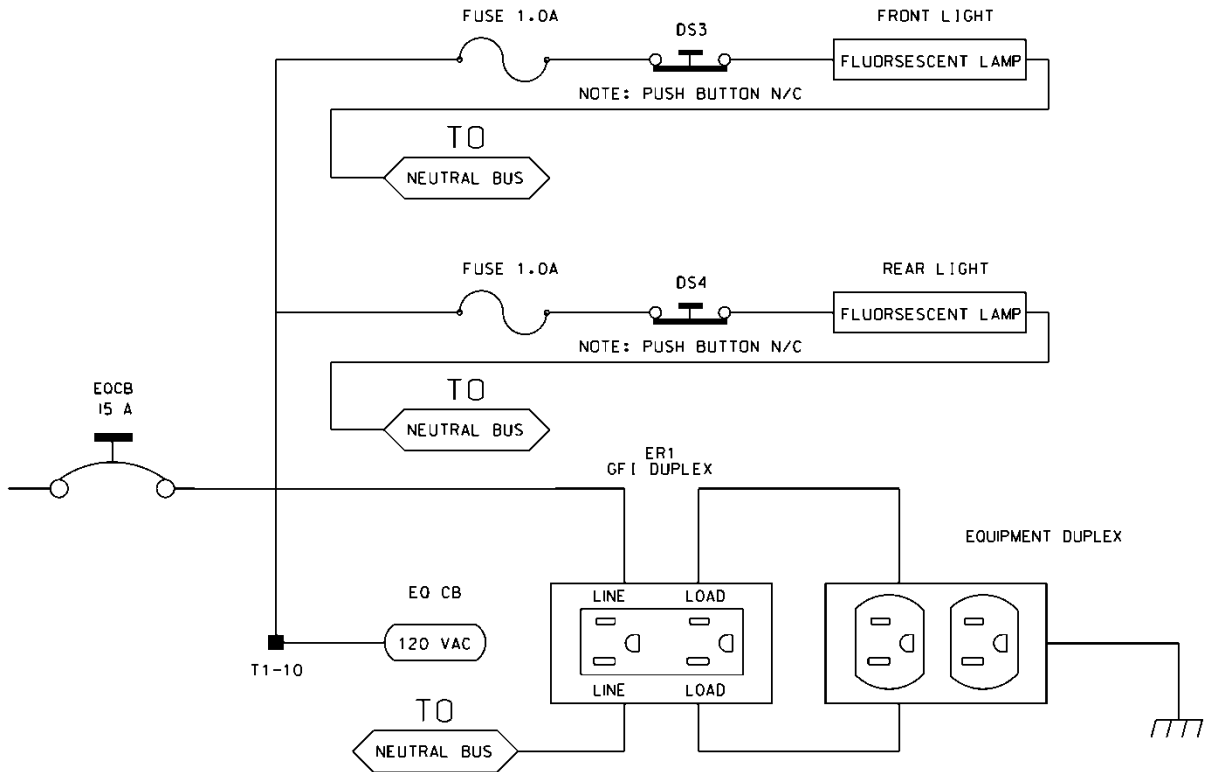

Furnish a police panel with a police panel door. For model 336S cabinets, mount the police panel on the rear door. Ensure that the police panel door permits access to the police panel when the main door is closed. Ensure that no rainwater can enter the cabinet even with the police panel door open. Provide a police panel door hinged on the right side as viewed from the front. Provide a police panel

W-5520**TS-18****Union County**

door lock that is keyed to a standard police/fire call box key. In addition to the requirements of LA Specification No. 54-053-08, provide the police panel with a toggle switch connected to switch the intersection operation between normal stop-and-go operation (AUTO) and manual operation (MANUAL). Ensure that manual control can be implemented using inputs and software such that the controller provides full programmed clearance times for the yellow clearance and red clearance for each phase while under manual control.

Provide a 1/4-inch locking phone jack in the police panel for a hand control to manually control the intersection. Provide sufficient room in the police panel for storage of a hand control and cord.

Ensure the 336S cabinet Input File is wired as follows:

| 336S Cabinet | | | | | | | | | | | | | | |
|------------------------------------|-----|-----|-----|-----|-----|-----|-----|-----|-----|-----|-----|-----|-----|-----|
| Port-Bit/C-1 Pin Assignment | | | | | | | | | | | | | | |
| Slot # | 1 | 2 | 3 | 4 | 5 | 6 | 7 | 8 | 9 | 10 | 11 | 12 | 13 | 14 |
| C-1 (Spares) | 59 | 60 | 61 | 62 | 63 | 64 | 65 | 66 | 75 | 76 | 77 | 78 | 79 | 80 |
| Port | 3-2 | 1-1 | 3-4 | 1-3 | 3-1 | 1-2 | 3-3 | 1-4 | 2-5 | 5-5 | 5-6 | 5-1 | 5-2 | 6-7 |
| C-1 | 56 | 39 | 58 | 41 | 55 | 40 | 57 | 42 | 51 | 71 | 72 | 67 | 68 | 81 |
| Port | 2-1 | 1-5 | 2-3 | 1-7 | 2-2 | 1-6 | 2-4 | 1-8 | 2-6 | 5-7 | 5-8 | 5-3 | 5-4 | 6-8 |
| C-1 | 47 | 43 | 49 | 45 | 48 | 44 | 50 | 46 | 52 | 73 | 74 | 69 | 70 | 82 |

For model 332 base mounted cabinets, ensure terminals J14-E and J14-K are wired together on the rear of the Input File. Connect TB9-12 (J14 Common) on the Input Panel to T1-2 (AC-) on the rear of the PDA.

Provide detector test switches mounted at the top of the cabinet rack or other convenient location which may be used to place a call on each of eight phases based on the chart below. Provide three positions for each switch: On (place call), Off (normal detector operation), and Momentary On (place momentary call and return to normal detector operation after switch is released). Ensure that the switches are located such that the technician can read the controller display and observe the intersection.

W-5520**TS-19****Union County**

Connect detector test switches for cabinets as follows:

| 336S Cabinet | | 332 Cabinet | |
|-------------------------------|------------------|-------------------------------|------------------|
| Detector Call Switches | Terminals | Detector Call Switches | Terminals |
| Phase 1 | I1-F | Phase 1 | I1-W |
| Phase 2 | I2-F | Phase 2 | I4-W |
| Phase 3 | I3-F | Phase 3 | I5-W |
| Phase 4 | I4-F | Phase 4 | I8-W |
| Phase 5 | I5-F | Phase 5 | J1-W |
| Phase 6 | I6-F | Phase 6 | J4-W |
| Phase 7 | I7-F | Phase 7 | J5-W |
| Phase 8 | I8-F | Phase 8 | J8-W |

Provide the PCB 28/56 connector for the conflict monitor unit (CMU) with 28 independent contacts per side, dual-sided with 0.156 inch contact centers. Provide the PCB 28/56 connector contacts with solder eyelet terminations. Ensure all connections to the PCB 28/56 connector are soldered to the solder eyelet terminations.

Ensure that all cabinets have the CMU connector wired according to the 332 cabinet connector pin assignments (include all wires for auxiliary output file connection). Wire pins 13, 16, R, and U of the CMU connector to a separate 4 pin plug, P1, as shown below. Provide a second plug, P2, which will mate with P1 and is wired to the auxiliary output file as shown below. Provide an additional plug, P3, which will mate with P1 and is wired to the pedestrian yellow circuits as shown below. When no auxiliary output file is installed in the cabinet, provide wires for the green and yellow inputs for channels 11, 12, 17, and 18, the red inputs for channels 17 and 18, and the wires for the P2 plug. Terminate the two-foot wires with ring type lugs, insulated, and bundled for optional use.

| PIN | P1 | | P2 | | P3 | |
|------------|-----------------|----------------|-----------------|----------------|-----------------|----------------|
| | FUNCTION | CONN TO | FUNCTION | CONN TO | FUNCTION | CONN TO |
| 1 | CH-9G | CMU-13 | OLA-GRN | A123 | 2P-YEL | 114 |
| 2 | CH-9Y | CMU-16 | OLA-YEL | A122 | 4P-YEL | 105 |
| 3 | CH-10G | CMU-R | OLB-GRN | A126 | 6P-YEL | 120 |
| 4 | CH-10Y | CMU-U | OLB-YEL | A125 | 8P-YEL | 111 |

Do not provide the P20 terminal assembly (red monitor board) or red interface ribbon cable as specified in LA Specification No. 54-053-08.

W-5520**TS-20****Union County**

Provide a P20 connector that mates with and is compatible with the red interface connector mounted on the front of the conflict monitor. Ensure that the P20 connector and the red interface connector on the conflict monitor are center polarized to ensure proper connection. Ensure that removal of the P20 connector will cause the conflict monitor to recognize a latching fault condition and place the cabinet into flashing operation.

Wire the P20 connector to the output file and auxiliary output file using 22 AWG stranded wires. Ensure the length of these wires is a minimum of 42 inches in length. Provide a durable braided sleeve around the wires to organize and protect the wires.

Wire the P20 connector to the traffic signal red displays to provide inputs to the conflict monitor as shown below. Ensure the pedestrian Don't Walk circuits are wired to channels 13 through 16 of the P20 connector. When no auxiliary output file is installed in the cabinet, provide wires for channels 9 through 12 reds. Provide a wire for special function 1. Terminate the unused wires with ring type lugs, insulated, and bundled for optional use.

| P20 Connector | | | | | |
|----------------------|-----------------|----------------|------------|-----------------|----------------|
| PIN | FUNCTION | CONN TO | PIN | FUNCTION | CONN TO |
| 1 | Channel 15 Red | 119 | 2 | Channel 16 Red | 110 |
| 3 | Channel 14 Red | 104 | 4 | Chassis GND | 01-9 |
| 5 | Channel 13 Red | 113 | 6 | N/C | |
| 7 | Channel 12 Red | AUX 101 | 8 | Spec Function 1 | |
| 9 | Channel 10 Red | AUX 124 | 10 | Channel 11 Red | AUX 114 |
| 11 | Channel 9 Red | AUX 121 | 12 | Channel 8 Red | 107 |
| 13 | Channel 7 Red | 122 | 14 | Channel 6 Red | 134 |
| 15 | Channel 5 Red | 131 | 16 | Channel 4 Red | 101 |
| 17 | Channel 3 Red | 116 | 18 | Channel 2 Red | 128 |
| 19 | Channel 1 Red | 125 | 20 | Red Enable | 01-14 |

Ensure the controller unit outputs to the auxiliary output file are pre-wired to the C5 connector. When no auxiliary output file is installed in the cabinet, connect the C5 connector to a storage socket located on the Input Panel or on the rear of the PDA.

Do not wire pin 12 of the load switch sockets.

In addition to the requirements of LA Specification No. 54-053-08, ensure relay K1 on the Power Distribution Assembly (PDA) is a four pole relay and K2 on the PDA is a two pole relay.

Provide a two pole, ganged circuit breaker for the flash bus circuit. Ensure the flash bus circuit breaker is an inverse time circuit breaker rated for 10 amps at 120 VAC with a minimum of 10,000 RMS symmetrical amperes short circuit current rating. Do not provide the auxiliary switch feature on the flash bus circuit breaker. Ensure the ganged flash bus circuit breaker is certified by the circuit breaker manufacturer to provide gang tripping operation.

W-5520

TS-21

Union County

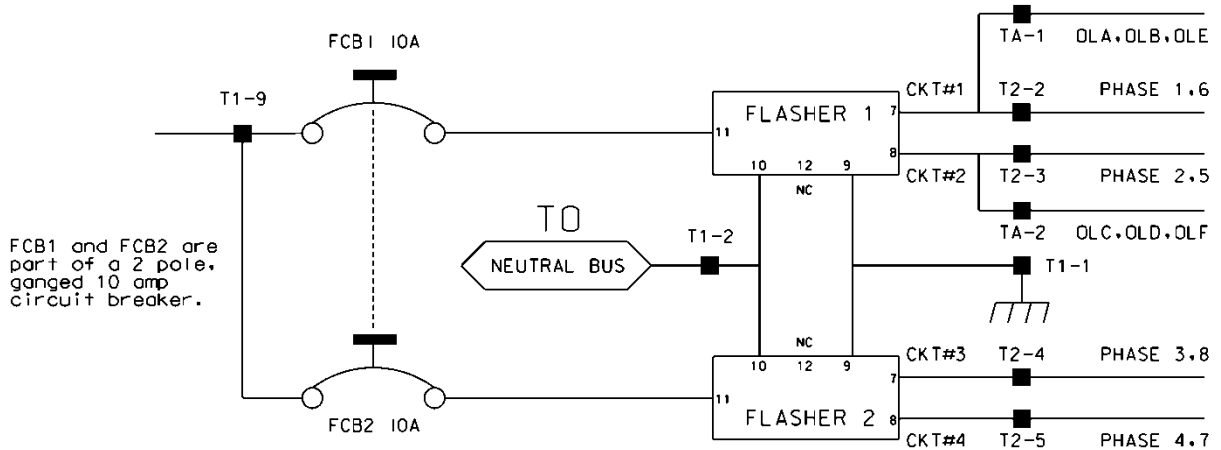

Ensure auxiliary output files are wired as follows:

| AUXILIARY OUTPUT FILE | |
|-------------------------------|-------------------------------------------------------|
| TERMINAL BLOCK TA ASSIGNMENTS | |
| POSITION | FUNCTION |
| 1 | Flasher Unit #1, Circuit 1/FTR1 (OLA, OLB)/FTR3 (OLE) |
| 2 | Flasher Unit #1, Circuit 2/FTR2 (OLC, OLD)/FTR3 (OLF) |
| 3 | Flash Transfer Relay Coils |
| 4 | AC - |
| 5 | Power Circuit 5 |
| 6 | Power Circuit 5 |
| 7 | Equipment Ground Bus |
| 8 | NC |

Provide four spare load resistors mounted in each cabinet. Ensure each load resistor is rated as shown in the table below. Wire one side of each load resistor to AC-. Connect the other side of each resistor to a separate terminal on a four (4) position terminal block. Mount the load resistors and terminal block either inside the back of Output File No. 1 or on the upper area of the Service Panel.

W-5520

TS-22

Union County

| ACCEPTABLE LOAD RESISTOR VALUES | |
|------------------------------------|-----------|
| VALUE (ohms) | WATTAGE |
| 1.5K – 1.9 K | 25W (min) |
| 2.0K – 3.0K | 10W (min) |

Provide Model 200 load switches, Model 204 flashers, Model 242 DC isolators, Model 252 AC isolators, and Model 206L power supply units that conform to CALTRANS' *Transportation Electrical Equipment Specifications* dated March 12, 2009 with Erratum 1.

C. Type 170 E Cabinet Physical Requirements:

Do not mold, cast, or scribe the name "City of Los Angeles" on the outside of the cabinet door as specified in LA Specification No. 54-053-08. Do not provide a Communications Terminal Panel as specified in LA Specification No. 54-053-08. Do not provide terminal block TBB on the Service Panel. Do not provide Cabinet Verification Test Program software or associated test jigs as specified in LA Specification No. 54-053-08.

Furnish unpainted, natural, aluminum cabinet shells. Ensure that all non-aluminum hardware on the cabinet is stainless steel or a Department approved non-corrosive alternate.

Ensure the lifting eyes, gasket channels, police panel, and all supports welded to the enclosure and doors are fabricated from 0.125 inch minimum thickness aluminum sheet and meet the same standards as the cabinet and doors.

Provide front and rear doors with latching handles that allow padlocking in the closed position. Furnish 0.75 inch minimum diameter stainless steel handles with a minimum 0.5 inch shank. Place the padlocking attachment at 4.0 inches from the handle shank center to clear the lock and key. Provide an additional 4.0 inches minimum gripping length.

Provide Corbin #2 locks on the front and rear doors. Provide one (1) Corbin #2 and one (1) police master key with each cabinet. Ensure main door locks allow removal of keys in the locked position only.

Provide a surge protection panel with 16 loop surge protection devices and designed to allow sufficient free space for wire connection/disconnection and surge protection device replacement. For model 332 cabinets, provide an additional 20 loop surge protection devices. Provide an additional two AC+ interconnect surge devices to protect one slot and eight DC surge protection devices to protect four slots. Provide no protection devices on slot I14.

For pole mounted cabinets, mount surge protection devices for the AC+ interconnect inputs, inductive loop detector inputs, and low voltage DC inputs on a swing down panel assembly fabricated from sturdy aluminum. Attach the swing down panel to the bottom rear cabinet rack assembly using thumb screws. Ensure the swing down panel allows for easy removal of the input file without removing the surge protection panel assembly or its parts. Have the surge protection devices mounted horizontally on the panel and soldered to the feed through terminals of four 14 position terminal blocks with #8 screws mounted on the other side. Ensure the top row of terminals is connected to the upper slots and the bottom row of terminals is connected to the bottom slots. Provide a 15 position copper equipment ground bus attached to the field terminal side (outside) of

the swing down panel for termination of loop lead-in shield grounds. Ensure that a Number 4 AWG green wire connects the surge protection panel assembly ground bus to the main cabinet equipment ground.

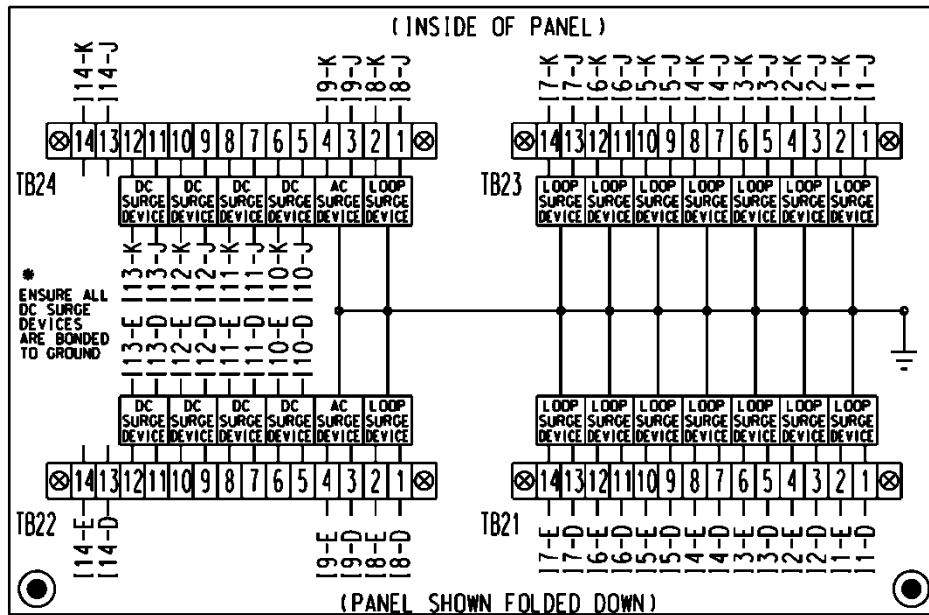
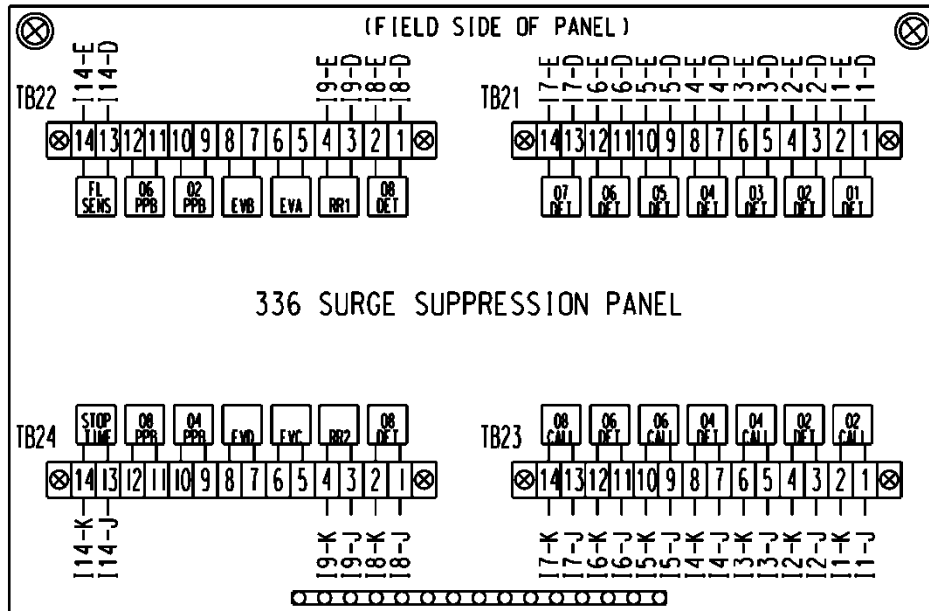

For base mounted cabinets, mount surge protection panels on the left side of the cabinet as viewed from the rear. Attach each panel to the cabinet rack assembly using bolts and make it easily removable. Mount the surge protection devices in vertical rows on each panel and connect the

W-5520**TS-24****Union County**

devices to one side of 12 position, double row terminal blocks with #8 screws. For each surge protection panel, terminate all grounds from the surge protection devices on a copper equipment ground bus attached to the surge protection panel. Wire the terminals to the rear of a standard input file using spade lugs for input file protection.

Provide permanent labels that indicate the slot and the pins connected to each terminal that may be viewed from the rear cabinet door. Label and orient terminals so that each pair of inputs is next to each other. Indicate on the labeling the input file (I or J), the slot number (1-14) and the terminal pins of the input slots (either D & E for upper or J & K for lower).

Provide a minimum 14 x 16 inch pull out, hinged top shelf located immediately below controller mounting section of the cabinet. Ensure the shelf is designed to fully expose the table surface outside the controller at a height approximately even with the bottom of the controller. Ensure the shelf has a storage bin interior which is a minimum of 1 inch deep and approximately the same dimensions as the shelf. Provide an access to the storage area by lifting the hinged top of the shelf. Fabricate the shelf and slide from aluminum or stainless steel and ensure the assembly can support the 2070L controller plus 15 pounds of additional weight. Ensure shelf has a locking mechanism to secure it in the fully extended position and does not inhibit the removal of the 2070L controller or removal of cards inside the controller when fully extended. Provide a locking mechanism that is easily released when the shelf is to be returned to its non-use position directly under the controller.

D. Model 2018 Enhanced Conflict Monitor:

Furnish Model 2018 Enhanced Conflict Monitors that provide monitoring of 18 channels. Ensure each channel consists of a green, yellow, and red field signal input. Ensure that the conflict monitor meets or exceeds CALTRANS' Transportation Electrical Equipment Specifications dated March 12, 2009, with Erratum 1 (hereafter referred to as CALTRANS's 2009 TEES) for a model 210 monitor unit and other requirements stated in this specification.

Ensure the conflict monitor is provided with an 18 channel conflict programming card. Pin EE and Pin T of the conflict programming card shall be connected together. Pin 16 of the conflict programming card shall be floating. Ensure that the absence of the conflict programming card will cause the conflict monitor to trigger (enter into fault mode), and remain in the triggered state until the programming card is properly inserted and the conflict monitor is reset.

Provide a conflict monitor that incorporates LED indicators into the front panel to dynamically display the status of the monitor under normal conditions and to provide a comprehensive review of field inputs with monitor status under fault conditions. Ensure that the monitor indicates the channels that were active during a conflict condition and the channels that experienced a failure for all other per channel fault conditions detected. Ensure that these indications and the status of each channel are retained until the Conflict Monitor is reset. Furnish LED indicators for the following:

- AC Power (Green LED indicator)
- VDC Failed (Red LED indicator)
- WDT Error (Red LED indicator)
- Conflict (Red LED indicator)
- Red Fail (Red LED indicator)
- Dual Indication (Red LED indicator)

W-5520**TS-25****Union County**

- Yellow/Clearance Failure (Red LED indicator)
- PCA/PC Ajar (Red LED indicator)
- Monitor Fail/Diagnostic Failure (Red LED indicator)
- 54 Channel Status Indicators (1 Red, 1 Yellow, and 1 Green LED indicator for each of the 18 channels)

Provide a switch to set the Red Fail fault timing. Ensure that when the switch is in the ON position the Red Fail fault timing value is set to 1350 +/- 150 ms (2018 mode). Ensure that when the switch is in the OFF position the Red Fail fault timing value is set to 850 +/- 150 ms (210 mode).

Provide a switch to set the Watchdog fault timing. Ensure that when the switch is in the ON position the Watchdog fault timing value is set to 1.0 +/- 0.1 s (2018 mode). Ensure that when the switch is in the OFF position the Watchdog fault timing value is set to 1.5 +/- 0.1 s (210 mode).

Provide a jumper or switch to set the AC line brown-out levels. Ensure that when the jumper is present or the switch is in the ON position the AC line dropout voltage threshold is 98 +/- 2 Vrms, the AC line restore voltage threshold is 103 +/- 2 Vrms, and the AC line brown-out timing value is set to 400 +/- 50ms (2018 mode). Ensure that when the jumper is not present or the switch is in the OFF position the AC line dropout voltage threshold is 92 +/- 2 Vrms, the AC line restore voltage threshold is 98 +/- 2 Vrms, and the AC line brown-out timing value is set to 80 +/- 17 ms (210 mode).

Provide a jumper or switch that will enable and disable the Watchdog Latch function. Ensure that when the jumper is not present or the switch is in the OFF position the Watchdog Latch function is disabled. In this mode of operation, a Watchdog fault will be reset following a power loss, brownout, or power interruption. Ensure that when the jumper is present or the switch is in the ON position the Watchdog Latch function is enabled. In this mode of operation, a Watchdog fault will be retained until a Reset command is issued.

Provide a jumper that will reverse the active polarity for pin #EE (output relay common). Ensure that when the jumper is not present pin #EE (output relay common) will be considered 'Active' at a voltage greater than 70 Vrms and 'Not Active' at a voltage less than 50 Vrms (Caltrans mode). Ensure that when the jumper is present pin #EE (output relay common) will be considered 'Active' at a voltage less than 50 Vrms and 'Not Active' at a voltage greater than 70 Vrms (Failsafe mode).

In addition to the connectors required by CALTRANS' 2009 TEES, provide the conflict monitor with a red interface connector mounted on the front of the monitor. Ensure the connector is a 20 pin, right angle, center polarized, male connector with latching clip locks and polarizing keys. Ensure the right angle solder tails are designed for a 0.062" thick printed circuit board. Keying of the connector shall be between pins 3 and 5, and between 17 and 19. Ensure the connector has two rows of pins with the odd numbered pins on one row and the even pins on the other row. Ensure the connector pin row spacing is 0.10" and pitch is 0.10". Ensure the mating length of the connector pins is 0.24". Ensure the pins are finished with gold plating 30μ" thick.

W-5520

TS-26

Union County

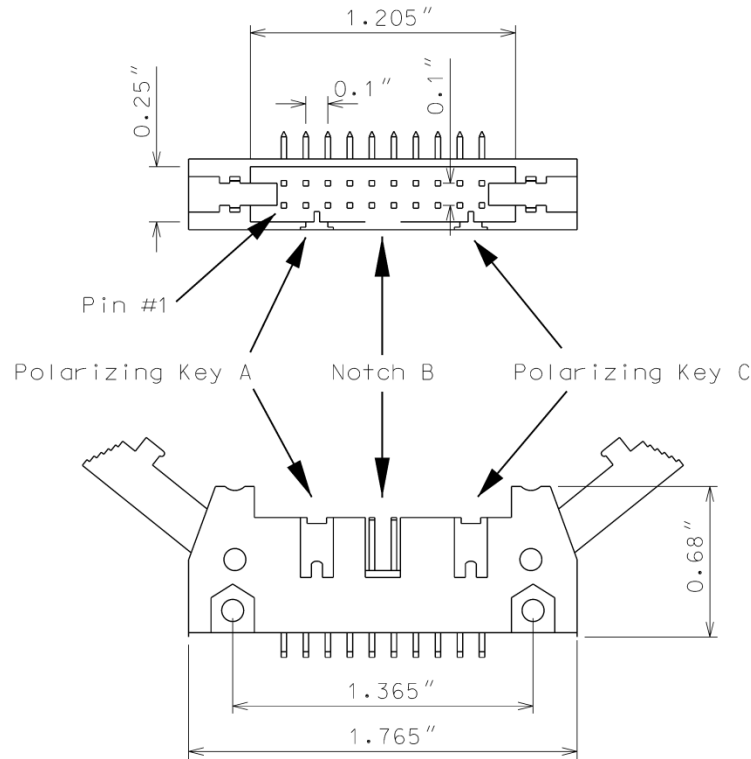

Ensure the red interface connector pins on the monitor have the following functions:

| Pin # | Function | Pin # | Function |
|-------|----------------|-------|--------------------|
| 1 | Channel 15 Red | 2 | Channel 16 Red |
| 3 | Channel 14 Red | 4 | Chassis Ground |
| 5 | Channel 13 Red | 6 | Special Function 2 |
| 7 | Channel 12 Red | 8 | Special Function 1 |
| 9 | Channel 10 Red | 10 | Channel 11 Red |
| 11 | Channel 9 Red | 12 | Channel 8 Red |
| 13 | Channel 7 Red | 14 | Channel 6 Red |
| 15 | Channel 5 Red | 16 | Channel 4 Red |
| 17 | Channel 3 Red | 18 | Channel 2 Red |
| 19 | Channel 1 Red | 20 | Red Enable |

Ensure that removal of the P20 cable connector will cause the conflict monitor to recognize a latching fault condition and place the cabinet into flashing operation.

W-5520**TS-27****Union County**

Provide Special Function 1 and Special Function 2 inputs to the unit which shall disable only Red Fail Monitoring when either input is sensed active. A Special Function input shall be sensed active when the input voltage exceeds 70 Vrms with a minimum duration of 550 ms. A Special Function input shall be sensed not active when the input voltage is less than 50 Vrms or the duration is less than 250 ms. A Special Function input is undefined by these specifications and may or may not be sensed active when the input voltage is between 50 Vrms and 70 Vrms or the duration is between 250 ms and 550 ms.

Ensure the conflict monitor recognizes field signal inputs for each channel that meet the following requirements:

- consider a Red input greater than 70 Vrms and with a duration of at least 500 ms as an “on” condition;
- consider a Red input less than 50 Vrms or with a duration of less than 200 ms as an “off” condition (no valid signal);
- consider a Red input between 50 Vrms and 70 Vrms or with a duration between 200 ms and 500 ms to be undefined by these specifications;
- consider a Green or Yellow input greater than 25 Vrms and with a duration of at least 500 ms as an “on” condition;
- consider a Green or Yellow input less than 15 Vrms or with a duration of less than 200 ms as an “off” condition; and
- consider a Green or Yellow input between 15 Vrms and 25 Vrms or with a duration between 200 ms and 500 ms to be undefined by these specifications.

Provide a conflict monitor that recognizes the faults specified by CALTRANS’ 2009 TEES and the following additional faults. Ensure the conflict monitor will trigger upon detection of a fault and will remain in the triggered (in fault mode) state until the unit is reset at the front panel or through the external remote reset input for the following failures:

1. **Red Monitoring or Absence of Any Indication (Red Failure):** A condition in which no “on” voltage signal is detected on any of the green, yellow, or red inputs to a given monitor channel. If a signal is not detected on at least one input (R, Y, or G) of a conflict monitor channel for a period greater than 1000 ms when used with a 170 controller and 1500 ms when used with a 2070 controller, ensure monitor will trigger and put the intersection into flash. If the absence of any indication condition lasts less than 700 ms when used with a 170 controller and 1200 ms when used with a 2070 controller, ensure conflict monitor will not trigger. Red fail monitoring shall be enabled on a per channel basis by the use of switches located on the conflict monitor. Have red monitoring occur when all of the following input conditions are in effect:
 - a) Red Enable input to monitor is active (Red Enable voltages are “on” at greater than 70 Vrms, off at less than 50 Vrms, undefined between 50 and 70 Vrms), and
 - b) Neither Special Function 1 nor Special Function 2 inputs are active.

- c) Pin #EE (output relay common) is not active
2. **Short/Missing Yellow Indication Fault (Clearance Error):** Yellow indication following a green is missing or shorter than 2.7 seconds (with ± 0.1 -second accuracy). If a channel fails to detect an “on” signal at the Yellow input for a minimum of 2.7 seconds (± 0.1 second) following the detection of an “on” signal at a Green input for that channel, ensure that the monitor triggers and generates a clearance/short yellow error fault indication. Short/missing yellow (clearance) monitoring shall be enabled on a per channel basis by the use of switches located on the conflict monitor. This fault shall not occur when the channel is programmed for Yellow Inhibit, when the Red Enable signal is inactive or pin #EE (output relay common) is active.
 3. **Dual Indications on the Same Channel:** In this condition, more than one indication (R,Y,G) is detected as “on” at the same time on the same channel. If dual indications are detected for a period greater than 500 ms, ensure that the conflict monitor triggers and displays the proper failure indication (Dual Ind fault). If this condition is detected for less than 200 ms, ensure that the monitor does not trigger. G-Y-R dual indication monitoring shall be enabled on a per channel basis by the use of switches located on the conflict monitor. G-Y dual indication monitoring shall be enabled for all channels by use of a switch located on the conflict monitor. This fault shall not occur when the Red Enable signal is inactive or pin #EE (output relay common) is active.
 4. **Configuration Settings Change:** The configuration settings are comprised of (as a minimum) the permissive diode matrix, dual indication switches, yellow disable jumpers, any option switches, any option jumpers, and the Watchdog Enable switch. Ensure the conflict monitor compares the current configuration settings with the previous stored configuration settings on power-up, on reset, and periodically during operation. If any of the configuration settings are changed, ensure that the conflict monitor triggers and causes the program card indicator to flash. Ensure that configuration change faults are only reset by depressing and holding the front panel reset button for a minimum of three seconds. Ensure the external remote reset input does not reset configuration change faults.

Ensure the conflict monitor will trigger and the AC Power indicator will flash at a rate of 2 Hz \pm 20% with a 50% duty cycle when the AC Line voltage falls below the “drop-out” level. Ensure the conflict monitor will resume normal operation when the AC Line voltage returns above the “restore” level. Ensure the AC Power indicator will remain illuminated when the AC voltage returns above the “restore” level. Should an AC Line power interruption occur while the monitor is in the fault mode, then upon restoration of AC Line power, the monitor will remain in the fault mode and the correct fault and channel indicators will be displayed.

Provide a flash interval of at least 6 seconds and at most 10 seconds in duration following a power-up, an AC Line interruption, or a brownout restore. Ensure the conflict monitor will suspend all fault monitoring functions, close the Output relay contacts, and flash the AC indicator at a rate of 4 Hz \pm 20% with a 50% duty cycle during this interval. Ensure the termination of the flash interval after at least 6 seconds if the Watchdog input has made 5 transitions between the True and False state and the AC Line voltage is greater than the “restore” level. If the watchdog input has not made

W-5520**TS-29****Union County**

5 transitions between the True and False state within 10 ± 0.5 seconds, the monitor shall enter a WDT error fault condition.

Ensure the conflict monitor will monitor an intersection with a minimum of four approaches using the four-section Flashing Yellow Arrow (FYA) vehicle traffic signal as outlined by the NCHRP 3-54 research project for protected-permissive left turn signal displays. Ensure the conflict monitor will operate in the FYA mode and FYAc (Compact) mode as specified below to monitor each channel pair for the following fault conditions: Conflict, Flash Rate Detection, Red Fail, Dual Indication, and Clearance. Provide a switch to select between the FYA mode and FYAc mode. Provide a switch to select each FYA phase movement for monitoring.

FYA mode

| FYA Signal Head | Phase 1 | Phase 3 | Phase 5 | Phase 7 |
|-----------------------|------------------|-------------------|-------------------|-------------------|
| Red Arrow | Channel 9 Red | Channel 10 Red | Channel 11 Red | Channel 12 Red |
| Yellow Arrow | Channel 9 Yellow | Channel 10 Yellow | Channel 11 Yellow | Channel 12 Yellow |
| Flashing Yellow Arrow | Channel 9 Green | Channel 10 Green | Channel 11 Green | Channel 12 Green |
| Green Arrow | Channel 1 Green | Channel 3 Green | Channel 5 Green | Channel 7 Green |

FYAc mode

| FYA Signal Head | Phase 1 | Phase 3 | Phase 5 | Phase 7 |
|-----------------------|------------------|------------------|------------------|-------------------|
| Red Arrow | Channel 1 Red | Channel 3 Red | Channel 5 Red | Channel 7 Red |
| Yellow Arrow | Channel 1 Yellow | Channel 3 Yellow | Channel 5 Yellow | Channel 7 Yellow |
| Flashing Yellow Arrow | Channel 1 Green | Channel 3 Green | Channel 5 Green | Channel 7 Green |
| Green Arrow | Channel 9 Green | Channel 9 Yellow | Channel 10 Green | Channel 10 Yellow |

If a FYA channel pair is enabled for FYA operation, the conflict monitor will monitor the FYA logical channel pair for the additional following conditions:

1. **Conflict:** Channel conflicts are detected based on the permissive programming jumpers on the program card. This operation remains unchanged from normal operation except for the solid Yellow arrow (FYA clearance) signal.
2. **Yellow Change Interval Conflict:** During the Yellow change interval of the Permissive Turn channel (flashing Yellow arrow) the conflict monitor shall verify that no conflicting channels to the solid Yellow arrow channel (clearance) are active. These conflicting channels shall be determined by the program card compatibility programming of the Permissive Turn channel (flashing Yellow arrow). During the Yellow change interval of the Protected Turn channel (solid Green arrow) the conflict monitor shall verify that no conflicting channels to the solid Yellow arrow channel (clearance) are active as determined by the program card compatibility programming of the Protected Turn channel (solid Green arrow).
3. **Flash Rate Detection:** The conflict monitor unit shall monitor for the absence of a valid flash rate for the Permissive turn channel (flashing Yellow arrow). If the Permissive turn channel (flashing Yellow arrow) is active for a period greater than 1600 milliseconds, ensure the conflict monitor triggers and puts the intersection into flash. If the Permissive turn channel (flashing Yellow arrow) is active for a period less than 1400 milliseconds, ensure the conflict monitor does not trigger. Ensure the conflict monitor will remain in the triggered (in fault mode) state until the unit is reset at the front panel or through the external remote reset input. Provide a jumper or switch that will enable and disable the Flash Rate Detection function. Ensure that when the jumper is not present or the switch is in the OFF position the Flash Rate Detection function is enabled. Ensure that when the jumper is present or the switch is in the ON position the Flash Rate Detection function is disabled.
4. **Red Monitoring or Absence of Any Indication (Red Failure):** The conflict monitor unit shall detect a red failure if there is an absence of voltage on all four of the inputs of a FYA channel pair (RA, YA, FYA, GA).
5. **Dual Indications on the Same Channel:** The conflict monitor unit shall detect a dual indication if two or more inputs of a FYA channel pair (RA, YA, FYA, GA) are “on” at the same time.
6. **Short/Missing Yellow Indication Fault (Clearance Error):** The conflict monitor unit shall monitor the solid Yellow arrow for a clearance fault when terminating both the Protected Turn channel (solid Green arrow) interval and the Permissive Turn channel (flashing Yellow arrow) interval.

Ensure that the conflict monitor will log at least nine of the most recent events detected by the monitor in non-volatile EEPROM memory (or equivalent). For each event, record at a minimum the time, date, type of event, status of each field signal indication with RMS voltage, and specific channels involved with the event. Ensure the conflict monitor will log the following events: monitor reset, configuration, previous fault, and AC line. Furnish the signal sequence log that shows all channel states (Greens, Yellows, and Reds) and the Red Enable State for a minimum of 2 seconds prior to the current fault trigger point. Ensure the display resolution of the inputs for the signal sequence log is not greater than 50 ms.

W-5520**TS-31****Union County**

For conflict monitors used within an Ethernet communications system, provide a conflict monitor with an Ethernet 10/100 Mbps, RJ-45 port for data communication access to the monitor by a local notebook computer and remotely via a workstation or notebook computer device connected to the signal system local area network. The Ethernet port shall be electrically isolated from the conflict monitor's electronics and shall provide a minimum of 1500 Vrms isolation. Integrate monitor with Ethernet network in cabinet. Provide software to retrieve the time and date from a network server in order to synchronize the on-board times between the conflict monitor and the controller. Furnish and install the following Windows based, graphic user interface software on workstations and notebook computers where the signal system client software is installed: 1) software to view and retrieve all event log information, 2) software that will search and display a list of conflict monitor IP addresses and IDs on the network, and 3) software to change the conflict monitor's network parameters such as IP address and subnet mask.

For non-Ethernet connected monitors, provide a RS-232C/D compliant port (DB-9 female connector) on the front panel of the conflict monitor in order to provide communications from the conflict monitor to the 170/2070 controller or to a Department-furnished laptop computer. Electrically isolate the port interface electronics from all monitor electronics, excluding Chassis Ground. Ensure that the controller can receive all event log information through a controller Asynchronous Communications Interface Adapter (Type 170E) or Async Serial Comm Module (2070). Furnish and connect a serial cable from the conflict monitor's DB-9 connector to Comm Port 1 of the 2070 controller. Ensure conflict monitor communicates with the controller. Provide a Windows based graphic user interface software to communicate directly through the same monitor RS-232C/D compliant port to retrieve and view all event log information to a Department-furnished laptop computer. The RS-232C/D compliant port on the monitor shall allow the monitor to function as a DCE device with pin connections as follows:

| Conflict Monitor RS-232C/D (DB-9 Female) Pinout | | |
|--------------------------------------------------------|-----------------|------------|
| Pin Number | Function | I/O |
| 1 | DCD | O |
| 2 | TX Data | O |
| 3 | RX Data | I |
| 4 | DTR | I |
| 5 | Ground | - |
| 6 | DSR | O |
| 7 | CTS | I |
| 8 | RTS | O |
| 9 | NC | - |

W-5520

TS-32

Union County

MONITOR BOARD EDGE CONNECTOR

| Pin # | Function (Back Side) | Pin # | Function (Component Side) |
|--------------|-----------------------------|--------------|----------------------------------|
| 1 | Channel 2 Green | A | Channel 2 Yellow |
| 2 | Channel 13 Green | B | Channel 6 Green |
| 3 | Channel 6 Yellow | C | Channel 15 Green |
| 4 | Channel 4 Green | D | Channel 4 Yellow |
| 5 | Channel 14 Green | E | Channel 8 Green |
| 6 | Channel 8 Yellow | F | Channel 16 Green |
| 7 | Channel 5 Green | H | Channel 5 Yellow |
| 8 | Channel 13 Yellow | J | Channel 1 Green |
| 9 | Channel 1 Yellow | K | Channel 15 Yellow |
| 10 | Channel 7 Green | L | Channel 7 Yellow |
| 11 | Channel 14 Yellow | M | Channel 3 Green |
| 12 | Channel 3 Yellow | N | Channel 16 Yellow |
| 13 | Channel 9 Green | P | Channel 17 Yellow |
| 14 | Channel 17 Green | R | Channel 10 Green |
| 15 | Channel 11 Yellow | S | Channel 11 Green |
| 16 | Channel 9 Yellow | T | Channel 18 Yellow |
| 17 | Channel 18 Green | U | Channel 10 Yellow |
| -- | | -- | |
| 18 | Channel 12 Yellow | V | Channel 12 Green |
| 19 | Channel 17 Red | W | Channel 18 Red |
| 20 | Chassis Ground | X | Not Assigned |
| 21 | AC- | Y | DC Common |
| 22 | Watchdog Timer | Z | External Test Reset |
| 23 | +24VDC | AA | +24VDC |
| 24 | Tied to Pin 25 | BB | Stop Time (Output) |
| 25 | Tied to Pin 24 | CC | Not Assigned |
| 26 | Not Assigned | DD | Not Assigned |
| 27 | Relay Output, Side #3, N.O. | EE | Relay Output, Side #2, Common |
| 28 | Relay Output, Side #1, N.C. | FF | AC+ |

-- Slotted for keying between Pins 17/U and 18/V

W-5520

TS-33

Union County

CONFLICT PROGRAM CARD PIN ASSIGNMENTS

| Pin # | Function (Back Side) | Pin # | Function (Component Side) |
|--------------|-----------------------------|--------------|----------------------------------|
| 1 | Channel 2 Green | A | Channel 1 Green |
| 2 | Channel 3 Green | B | Channel 2 Green |
| 3 | Channel 4 Green | C | Channel 3 Green |
| 4 | Channel 5 Green | D | Channel 4 Green |
| 5 | Channel 6 Green | E | Channel 5 Green |
| 6 | Channel 7 Green | F | Channel 6 Green |
| 7 | Channel 8 Green | H | Channel 7 Green |
| 8 | Channel 9 Green | J | Channel 8 Green |
| 9 | Channel 10 Green | K | Channel 9 Green |
| 10 | Channel 11 Green | L | Channel 10 Green |
| 11 | Channel 12 Green | M | Channel 11 Green |
| 12 | Channel 13 Green | N | Channel 12 Green |
| 13 | Channel 14 Green | P | Channel 13 Green |
| 14 | Channel 15 Green | R | Channel 14 Green |
| 15 | Channel 16 Green | S | Channel 15 Green |
| 16 | N/C | T | PC AJAR |
| 17 | Channel 1 Yellow | U | Channel 9 Yellow |
| 18 | Channel 2 Yellow | V | Channel 10 Yellow |
| 19 | Channel 3 Yellow | W | Channel 11 Yellow |
| 20 | Channel 4 Yellow | X | Channel 12 Yellow |
| 21 | Channel 5 Yellow | Y | Channel 13 Yellow |
| 22 | Channel 6 Yellow | Z | Channel 14 Yellow |
| 23 | Channel 7 Yellow | AA | Channel 15 Yellow |
| 24 | Channel 8 Yellow | BB | Channel 16 Yellow |
| -- | | -- | |
| 25 | Channel 17 Green | CC | Channel 17 Yellow |
| 26 | Channel 18 Green | DD | Channel 18 Yellow |
| 27 | Channel 16 Green | EE | PC AJAR (Program Card) |
| 28 | Yellow Inhibit Common | FF | Channel 17 Green |

-- Slotted for keying between Pins 24/BB and 25/CC

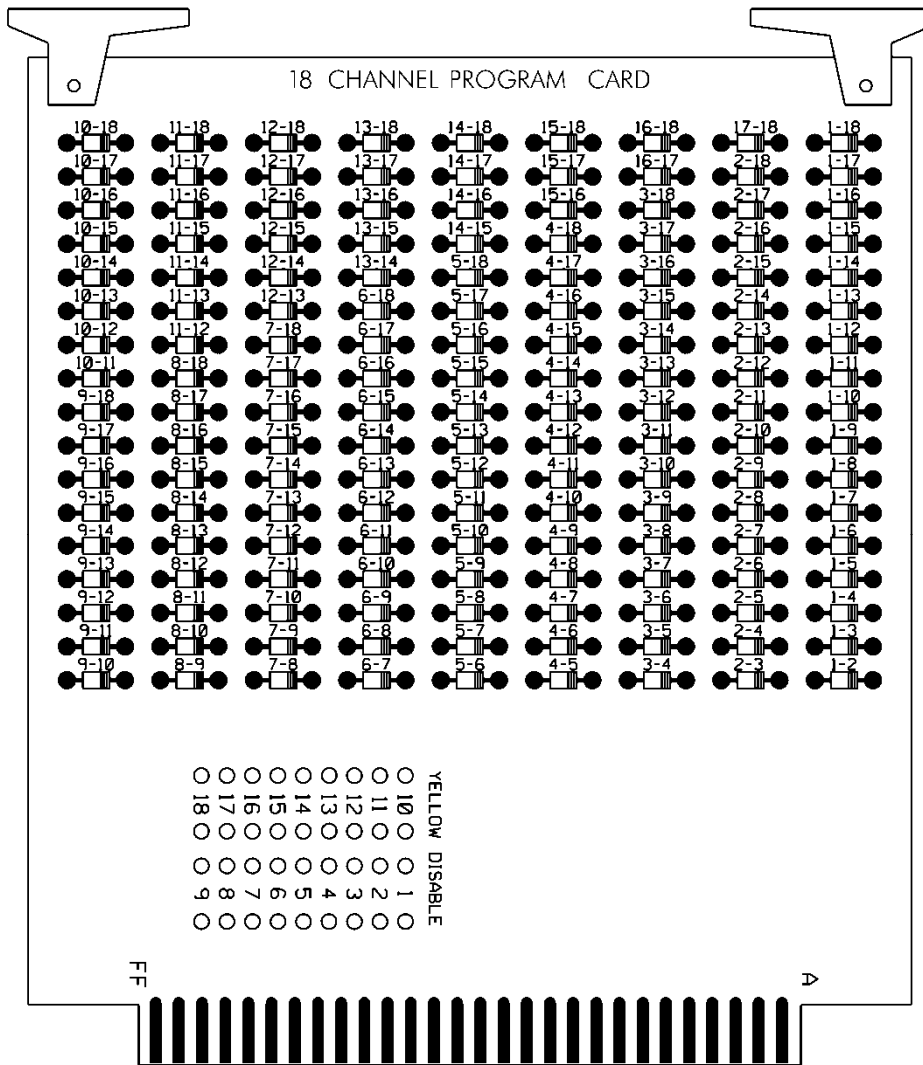

3.3. MATERIALS – TYPE 170 DETECTOR SENSOR UNITS

Furnish detector sensor units that comply with Chapter 5 Section 1, “General Requirements,” and Chapter 5 Section 2, “Model 222 & 224 Loop Detector Sensor Unit Requirements,” of the CALTRANS “Transportation Electrical Equipment Specifications” dated March 12, 2009 with Erratum 1.

3.4. MATERIALS – TYPE 2070E CONTROLLERS

Conform to CALTRANS *Transportation Electrical Equipment Specifications* (TEES) (dated March 12, 2009, plus Errata 1 dated January 21, 2010) except as required herein.

Furnish Model 2070E controllers. Ensure that removal of the CPU module from the controller will place the intersection into flash.

The Department will provide software at the beginning of the burning-in period. Contractor shall give 5 working days notice before needing software. Program software provided by the Department.

Provide Model 2070E controllers with the latest version of OS9 operating software and device drivers, composed of the unit chassis and at a minimum the following modules and assemblies:

- MODEL 2070-1E, CPU Module, Single Board, with 8Mb Datakey (blue in color)
- MODEL 2070-2A or approved MODEL 2070-2E, Field I/O Module (FI/O)
 - Note: Configure the Field I/O Module to disable both the External WDT Shunt/Toggle Switch and SP3 (SP3 active indicator is “off”)
- MODEL 2070-3B, Front Panel Module (FP), Display B (8x40)
- MODEL 2070-4, Power Supply Module, 10 AMP
- MODEL 2070-7A, Async Serial Com Module (9-pin RS-232)

For each master controller location, install a Department-furnished 4G cellular modem to accomplish the interface to the Department-furnished microcomputers. Include all necessary hardware to ensure communications, including, but not limited to, an Ethernet patch cable identical to the type installed with the Ethernet edge switch to connect to the 4G cellular modem. The Department will be responsible for any programming necessary for communications.

3.5. MATERIALS – MODEL 2010ECLip ENHANCED CONFLICT MONITOR

Furnish Model 2010 ECLip Enhanced Conflict Monitors to replace existing 2010ECL conflict monitors and provide Ethernet communications in existing signal controllers as shown in the plans.

Furnish Model 2010 Enhanced Conflict Monitors that provide monitoring of 16 channels. Ensure each channel consists of a green, yellow, and red field signal input. Ensure that the conflict monitor meets or exceeds CALTRANS Transportation Electrical Equipment Specifications dated March 12, 2009 with Erratum 1 (hereafter referred to as CALTRANS’s 2009 TEES) for a model 210 monitor unit and other requirements stated in this specification. The Department reserves the right to view the certification of the electrical and environmental testing results.

Ensure the conflict monitor is provided with a 16 channel conflict programming card. Pin 16 and Pin T of the programming card shall be connected together. Ensure that the absence of the conflict programming card will cause the conflict monitor to trigger (enter into fault mode), and remain in the triggered state until the programming card is properly inserted and the conflict monitor is reset.

Provide a conflict monitor that incorporates LED indicators into the front panel to dynamically display the status of the monitor under normal conditions and to provide a comprehensive review of field inputs with monitor status under fault conditions. Ensure that the monitor indicates the channels that were active during a conflict condition and the channels that experienced a failure for all other per channel fault conditions detected. Ensure that these indications and the status of each channel are retained until the Conflict Monitor is reset. Furnish LED indicators for the following:

- AC Power (Green LED indicator)
- VDC Failed (Red LED indicator)
- WDT Error (Red LED indicator)
- Conflict (Red LED indicator)
- Red Fail (Red LED indicator)
- Dual Indication (Red LED indicator)
- Yellow/Clearance Failure (Red LED indicator)
- PCA/PC Ajar (Red LED indicator)
- Monitor Fail/Diagnostic Failure (Red LED indicator)

- 48 Channel Status Indicators (1 Red, 1 Yellow, and 1 Green LED indicator for each of the 16 channels)

Provide a switch to set the Red Fail fault timing. Ensure that when the switch is in the ON position the Red Fail fault timing value is set to 1350 +/- 150 ms (2010 mode). Ensure that when the switch is in the OFF position the Red Fail fault timing value is set to 850 +/- 150 ms (210 mode).

Provide a switch to set the Watchdog fault timing. Ensure that when the switch is in the ON position the Watchdog fault timing value is set to 1.0 +/- 0.1 s (2010 mode). Ensure that when the switch is in the OFF position the Watchdog fault timing value is set to 1.5 +/- 0.1 s (210 mode).

Provide a jumper or switch to set the AC line brown-out levels. Ensure that when the jumper is present or the switch is in the ON position the AC line dropout voltage threshold is 98 +/- 2 Vrms, the AC line restore voltage threshold is 103 +/- 2 Vrms, and the AC line brown-out timing value is set to 400 +/- 50 ms (2010 mode). Ensure that when the jumper is not present or the switch is in the OFF position the AC line dropout voltage threshold is 92 +/- 2 Vrms, the AC line restore voltage threshold is 98 +/- 2 Vrms, and the AC line brown out-timing value is set to 80 +/- 17 ms (210 mode).

Provide a jumper or switch that will enable and disable the Watchdog Latch function. Ensure that when the jumper is not present or the switch is in the OFF position the Watchdog Latch function is disabled. In this mode of operation, a Watchdog fault will be reset following a power loss, brownout, or power interruption. Ensure that when the jumper is present or the switch is in the ON position the Watchdog Latch function is enabled. In this mode of operation, a Watchdog fault will be retained until a Reset command is issued.

In addition to the connectors required by CALTRANS's 2009 TEES, provide the conflict monitor with a red interface connector mounted on the front of the monitor. Ensure the connector is a 20 pin, right angle, center polarized, male connector with latching clip locks and polarizing keys. Ensure the right angle solder tails are designed for a 0.062" thick printed circuit board. Keying of the connector shall be between pins 3 and 5, and between 17 and 19. Ensure the connector has two rows of pins with the odd numbered pins on one row, and the even pins on the other row. Ensure the connector pin row spacing is 0.10" and pitch is 0.10". Ensure the mating length of the connector pins is 0.24". Ensure the pins are finished with gold plating 30μ" thick.

W-5520

TS-37

Union County

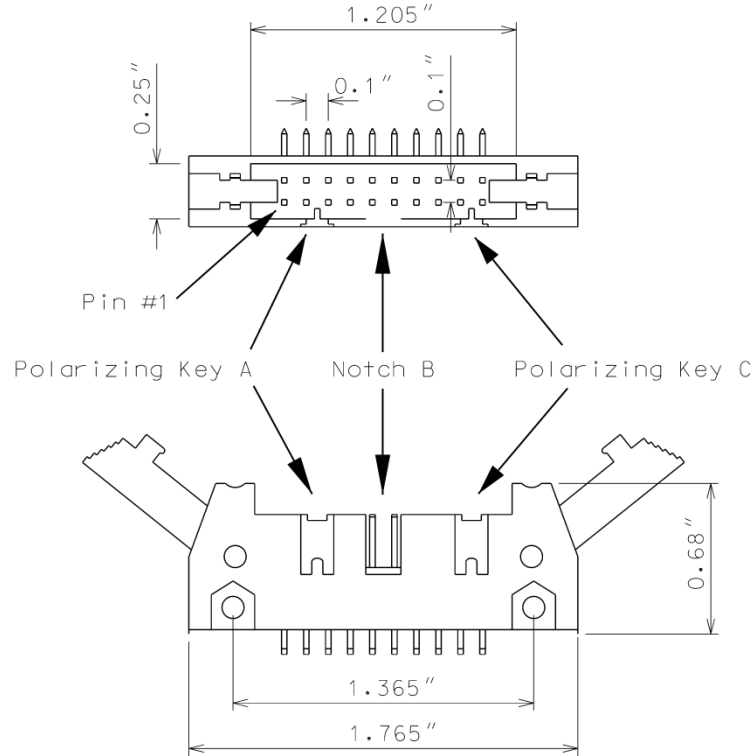

Ensure the red interface connector pins on the monitor have the following functions:

| Pin # | Function | Pin # | Function |
|-------|----------------|-------|--------------------|
| 1 | Channel 15 Red | 2 | Channel 16 Red |
| 3 | Channel 14 Red | 4 | Chassis Ground |
| 5 | Channel 13 Red | 6 | Special Function 2 |
| 7 | Channel 12 Red | 8 | Special Function 1 |
| 9 | Channel 10 Red | 10 | Channel 11 Red |
| 11 | Channel 9 Red | 12 | Channel 8 Red |
| 13 | Channel 7 Red | 14 | Channel 6 Red |
| 15 | Channel 5 Red | 16 | Channel 4 Red |
| 17 | Channel 3 Red | 18 | Channel 2 Red |
| 19 | Channel 1 Red | 20 | Red Enable |

Ensure that the removal of the P-20 red interface ribbon cable will cause the monitor to recognize a latching fault condition and place the cabinet into flashing operation.

Provide Special Function 1 and Special Function 2 inputs to the unit which shall disable only Red Fail Monitoring when either input is sensed active. A Special Function input shall be sensed active when the input voltage exceeds 70 Vrms with a minimum duration of 550 ms. A Special Function input shall be sensed not active when the input voltage is less than 50 Vrms or the duration is less than 250 ms. A Special Function input is undefined by these specifications and may or may not be sensed active when the input voltage is between 50 Vrms and 70 Vrms or the duration is between 250 ms and 550 ms.

Ensure the conflict monitor recognizes field signal inputs for each channel that meet the following requirements:

- consider a Red input greater than 70 Vrms and with a duration of at least 500 ms as an “on” condition;
- consider a Red input less than 50 Vrms or with a duration of less than 200 ms as an “off” condition (no valid signal);
- consider a Red input between 50 Vrms and 70 Vrms or with a duration between 200 ms and 500 ms to be undefined by these specifications;
- consider a Green or Yellow input greater than 25 Vrms and with a duration of at least 500 ms as an “on” condition;
- consider a Green or Yellow input less than 15 Vrms or with a duration of less than 200 ms as an “off” condition; and
- consider a Green or Yellow input between 15 Vrms and 25 Vrms or with a duration between 200 ms and 500 ms to be undefined by these specifications.

Provide a conflict monitor that recognizes the faults specified by CALTRANS’s 2009 TEES and the following additional faults. Ensure the conflict monitor will trigger upon detection of a fault and will remain in the triggered (in fault mode) state until the unit is reset at the front panel or through the external remote reset input for the following failures:

1. **Red Monitoring or Absence of Any Indication (Red Failure):** A condition in which no “on” voltage signal is detected on any of the green, yellow, or red inputs to a given monitor channel. If a signal is not detected on at least one input (R, Y, or G) of a conflict monitor channel for a period greater than 1000 ms when used with a 170 controller and 1500 ms when used with a 2070 controller, ensure monitor will trigger and put the intersection into flash. If the absence of any indication condition lasts less than 700 ms when used with a 170 controller and 1200 ms when used with a 2070 controller, ensure conflict monitor will not trigger. Have red monitoring occur when both the following input conditions are in effect:
 - a) Red Enable input to monitor is active (Red Enable voltages are “on” at greater than 70 Vrms, off at less than 50 Vrms, undefined between 50 and 70 Vrms), and
 - b) neither Special Function 1 nor Special Function 2 inputs are active.
2. **Short/Missing Yellow Indication Error (Sequence Error):** Yellow indication following a green is missing or shorter than 2.7 seconds (with ± 0.1 -second accuracy). If a channel fails to detect an “on” signal at the Yellow input for a minimum of 2.7 seconds (± 0.1 second) following the detection of an “on” signal at a Green input for that channel, ensure that the monitor triggers and generates a clearance/short yellow error fault indication. This fault shall not occur when the channel is programmed for Yellow Inhibit or when the Red Enable signal is inactive.
3. **Dual Indications on the Same Channel:** In this condition, more than one indication (R,Y,G) is detected as “on” at the same time on the same channel. If dual indications are detected for a period greater than 500 ms, ensure that the conflict monitor triggers and displays the proper failure indication (Dual Ind fault). If this condition is detected for less than 200 ms, ensure that the monitor does not trigger. G-Y-R dual indication monitoring shall be enabled on a per channel basis by use of switches located on the conflict monitor. G-Y dual indication monitoring shall be enabled for all channels by use of a switch located on the conflict monitor.

4. **Configuration Settings Change:** The configuration settings are comprised of (as a minimum) the permissive diode matrix, dual indication switches, yellow disable jumpers, any option switches, any option jumpers, and the Watchdog Enable switch. Ensure the conflict monitor compares the current configuration settings with the previous stored configuration settings on power-up, on reset, and periodically during operation. If any of the configuration settings are changed, ensure that the conflict monitor triggers and causes the program card indicator to flash. Ensure that configuration change faults are only reset by depressing and holding the front panel reset button for a minimum of three seconds. Ensure the external remote reset input does not reset configuration change faults.

Ensure the conflict monitor will trigger and the AC Power indicator will flash at a rate of $2 \text{ Hz} \pm 20\%$ with a 50% duty cycle when the AC Line voltage falls below the “drop-out” level. Ensure the conflict monitor will resume normal operation when the AC Line voltage returns above the “restore” level. Ensure the AC Power indicator will remain illuminated when the AC voltage returns above the “restore” level. Should an AC Line power interruption occur while the monitor is in the fault mode, then upon restoration of AC Line power, the monitor will remain in the fault mode and the correct fault and channel indicators will be displayed.

Provide a flash interval of at least 6 seconds and at most 10 seconds in duration following a power-up, an AC Line interruption, or a brownout restore. Ensure the conflict monitor will suspend all fault monitoring functions, close the Output relay contacts, and flash the AC indicator at a rate of $4 \text{ Hz} \pm 20\%$ with a 50% duty cycle during this interval. Ensure the termination of the flash interval after at least 6 seconds if the Watchdog input has made 5 transitions between the True and False state and the AC Line voltage is greater than the “restore” level. If the watchdog input has not made 5 transitions between the True and False state within 10 ± 0.5 seconds, the monitor shall enter a WDT error fault condition.

Ensure the conflict monitor will monitor an intersection with a minimum of four approaches using the four-section Flashing Yellow Arrow (FYA) vehicle traffic signal as outlined by the NCHRP 3-54 research project for protected-permissive left turn signal displays. Ensure the conflict monitor will operate in the FYA mode and FYAc (Compact) mode as specified below to monitor each channel pair for the following fault conditions: Conflict, Flash Rate Detection, Red Fail, Dual Indication, and Clearance. Provide a switch to select between the FYA mode and FYAc mode. Provide a switch to select each FYA phase movement for monitoring.

FYA mode

| FYA Signal Head | Phase 1 | Phase 3 | Phase 5 | Phase 7 |
|-----------------------|------------------|-------------------|-------------------|-------------------|
| Red Arrow | Channel 9 Red | Channel 10 Red | Channel 11 Red | Channel 12 Red |
| Yellow Arrow | Channel 9 Yellow | Channel 10 Yellow | Channel 11 Yellow | Channel 12 Yellow |
| Flashing Yellow Arrow | Channel 9 Green | Channel 10 Green | Channel 11 Green | Channel 12 Green |
| Green Arrow | Channel 1 Green | Channel 3 Green | Channel 5 Green | Channel 7 Green |

FYAc mode

| FYA Signal Head | Phase 1 | Phase 3 | Phase 5 | Phase 7 |
|-----------------------|------------------|------------------|------------------|-------------------|
| Red Arrow | Channel 1 Red | Channel 3 Red | Channel 5 Red | Channel 7 Red |
| Yellow Arrow | Channel 1 Yellow | Channel 3 Yellow | Channel 5 Yellow | Channel 7 Yellow |
| Flashing Yellow Arrow | Channel 1 Green | Channel 3 Green | Channel 5 Green | Channel 7 Green |
| Green Arrow | Channel 9 Green | Channel 9 Yellow | Channel 10 Green | Channel 10 Yellow |

If a FYA channel pair is enabled for FYA operation, the conflict monitor will monitor the FYA logical channel pair for the additional following conditions:

1. **Conflict:** Channel conflicts are detected based on the permissive programming jumpers on the program card. This operation remains unchanged from normal operation except for the solid Yellow arrow (FYA clearance) signal.
2. **Yellow Change Interval Conflict:** During the Yellow change interval of the Permissive Turn channel (flashing Yellow arrow) the conflict monitor shall verify that no conflicting channels to the solid Yellow arrow channel (clearance) are active. These conflicting channels shall be determined by the program card compatibility programming of the Permissive Turn channel (flashing Yellow arrow). During the Yellow change interval of the Protected Turn channel (solid Green arrow) the conflict monitor shall verify that no conflicting channels to the solid Yellow arrow channel (clearance) are active as determined by the program card compatibility programming of the Protected Turn channel (solid Green arrow).
3. **Flash Rate Detection:** The conflict monitor unit shall monitor for the absence of a valid flash rate for the Permissive turn channel (flashing Yellow arrow). If the Permissive turn channel (flashing Yellow arrow) is active for a period greater than 1600 milliseconds, ensure the conflict monitor triggers and puts the intersection into flash. If the Permissive turn channel (flashing Yellow arrow) is active for a period less than 1400 milliseconds, ensure the conflict monitor does not trigger. Ensure the conflict monitor will remain in the triggered (in fault mode) state until the unit is reset at the front panel or through the external remote reset input. Provide a jumper or switch that will enable and disable the Flash Rate Detection function. Ensure that when the jumper is not present or the switch is in the OFF position the Flash Rate Detection function is enabled. Ensure that when the jumper is present or the switch is in the ON position the Flash Rate Detection function is disabled.
4. **Red Monitoring or Absence of Any Indication (Red Failure):** The conflict monitor unit shall detect a red failure if there is an absence of voltage on all four of the inputs of a FYA channel pair (RA, YA, FYA, GA).
5. **Dual Indications on the Same Channel:** The conflict monitor unit shall detect a dual indication if two or more inputs of a FYA channel pair (RA, YA, FYA, GA) are “on” at the same time.

6. **Short/Missing Yellow Indication Fault (Clearance Error):** The conflict monitor unit shall monitor the solid Yellow arrow for a clearance fault when terminating both the Protected Turn channel (solid Green arrow) interval and the Permissive Turn channel (flashing Yellow arrow) interval.

Ensure that the conflict monitor will log at least nine of the most recent events detected by the monitor in non-volatile EEPROM memory (or equivalent). For each event, record at a minimum the time, date, type of event, status of each field signal indication with RMS voltage, and specific channels involved with the event. Ensure the conflict monitor will log the following events: monitor reset, configuration, previous fault, and AC line. Furnish the signal sequence log that shows all channel states (Greens, Yellows, and Reds) and the Red Enable State for a minimum of 2 seconds prior to the current fault trigger point. Ensure the display resolution of the inputs for the signal sequence log is not greater than 50 ms.

For conflict monitors used within an Ethernet communications system, provide a conflict monitor with an Ethernet 10/100 Mbps, RJ-45 port for data communication access to the monitor by a local notebook computer and remotely via a workstation or notebook computer device connected to the signal system local area network. The Ethernet port shall be electrically isolated from the conflict monitor's electronics and shall provide a minimum of 1500 Vrms isolation. Integrate monitor with Ethernet network in cabinet. Provide software to retrieve the time and date from a network server in order to synchronize the on-board times between the conflict monitor and the controller. Furnish and install the following Windows based, graphic user interface software on workstations and notebook computers where the signal system client software is installed: 1) software to view and retrieve all event log information, 2) software that will search and display a list of conflict monitor IP addresses and IDs on the network, and 3) software to change the conflict monitor's network parameters such as IP address and subnet mask.

For non-Ethernet connected monitors, provide a RS-232C/D compliant port (DB-9 female connector) on the front panel of the conflict monitor in order to provide communications from the conflict monitor to the 170/2070 controller or to a Department-furnished laptop computer. Electrically isolate the port interface electronics from all monitor electronics, excluding Chassis Ground. Ensure that the controller can receive all event log information through a controller Asynchronous Communications Interface Adapter (Type 170E) or Async Serial Comm Module (2070). Furnish and connect a serial cable from the conflict monitor's DB-9 connector to Comm Port 1 of the 2070 controller. Ensure conflict monitor communicates with the controller. Provide a Windows based graphic user interface software to communicate directly through the same monitor RS-232C/D compliant port to retrieve and view all event log information to a Department-furnished laptop computer. The RS-232C/D compliant port on the monitor shall allow the monitor to function as a DCE device with pin connections as follows:

| Conflict Monitor RS-232C/D (DB-9 Female) Pinout | | |
|--------------------------------------------------------|-----------------|------------|
| Pin Number | Function | I/O |
| 1 | DCD | O |
| 2 | TX Data | O |
| 3 | RX Data | I |
| 4 | DTR | I |
| 5 | Ground | - |
| 6 | DSR | O |
| 7 | CTS | I |
| 8 | RTS | O |
| 9 | NC | - |

4. ETHERNET EDGE SWITCH

Furnish and install an Ethernet edge switch for Ethernet communications at field devices as shown in the plans.

4.1. DESCRIPTION

A. Ethernet Edge Switch:

Furnish, program and install a hardened, field Ethernet edge switch (hereafter “edge switch”) for traffic signal controllers as specified below. Ensure that the edge switch provides wire-speed, fast Ethernet connectivity at transmission rates of 100 megabits per second from each remote ITS device location to the routing switches.

Contact Division 10 for the necessary network configuration data for programming the new Field Ethernet Switches, including but not limited to, the Project IP Address, Default Gateway, Subnet Mask and VLAN ID information. The Division will provide this data within five (5) working days upon request from contractor.

B. Network Management:

Ensure that the edge switch is fully compatible with the Division’s existing Network Management Software.

4.2. MATERIALS

A. General:

Ensure that the edge switch is fully compatible and interoperable with the Ethernet network interface and that the edge switch supports half and full duplex Ethernet communications.

Furnish an edge switch that provides 99.999% error-free operation, and that complies with the Electronic Industries Alliance (EIA) Ethernet data communication requirements using single-mode fiber-optic transmission medium and copper transmission medium. Ensure that the edge switch has a minimum mean time between failures (MTBF) of 10 years, or 87,600 hours, as calculated using the Bellcore/Telcordia SR-332 standard for reliability prediction.

B. Standards:

Ensure that the edge switch complies with all applicable IEEE networking standards for Ethernet communications, including but not limited to:

- IEEE 802.1D standard for media access control (MAC) bridges used with the Spanning Tree Protocol (STP);
- IEEE 802.1Q standard for port-based virtual local area networks (VLANs);
- IEEE 802.1P standard for Quality of Service (QoS);
- IEEE 802.1w standard for MAC bridges used with the Rapid Spanning Tree Protocol (RSTP);
- IEEE 802.1s standard for MAC bridges used with the Multiple Spanning Tree Protocol;
- IEEE 802.1x standard for port based network access control, including RADIUS;
- IEEE 802.3 standard for local area network (LAN) and metropolitan area network (MAN) access and physical layer specifications;
- IEEE 802.3u supplement standard regarding 100 Base TX/100 Base FX;
- IEEE 802.3x standard regarding flow control with full duplex operation; and
- IFC 2236 regarding IGMP v2 compliance.

C. Functional:

Ensure that the edge switch supports all Layer 2 management features and certain Layer 3 features related to multicast data transmission and routing. These features shall include, but not be limited to:

- An STP healing/convergence rate that meets or exceeds specifications published in the IEEE 802.1D standard.
- An RSTP healing/convergence rate that meets or exceeds specifications published in the IEEE 802.1w standard.
- An Ethernet edge switch that is a port-based VLAN and supports VLAN tagging that meets or exceeds specifications as published in the IEEE 802.1Q standard, and has a minimum 4-kilobit VLAN address table (254 simultaneous).
- A forwarding/filtering rate that is a minimum of 14,880 packets per second for 10 megabits per second and 148,800 packets per second for 100 megabits per second.
- A minimum 4-kilobit MAC address table.
- Support of Traffic Class Expediting and Dynamic Multicast Filtering.
- Support of, at a minimum, snooping of Version 2 of the Internet Group Management Protocol (IGMP).
- Support of remote and local setup and management via telnet or secure Web-based GUI and command line interfaces.
- Support of the Simple Network Management Protocol version 3 (SNMPv3). Verify that the Ethernet edge switch can be accessed using the resident EIA-232 management port, a telecommunication network, or the Trivial File Transfer Protocol (TFTP).
- Port security through controlling access by the users. Ensure that the Ethernet edge switch has the capability to generate an alarm and shut down ports when an unauthorized user accesses the network.
- Support of remote monitoring (RMON-I) of the Ethernet agent.
- Support of the TFTP and SNTP. Ensure that the Ethernet edge switch supports port mirroring for troubleshooting purposes when combined with a network analyzer.

D. Physical Features:

Ports: Provide 10/100 Mbps auto-negotiating ports (RJ-45) copper Fast Ethernet ports for all edge switches. Provide auto-negotiation circuitry that will automatically negotiate the highest possible data rate and duplex operation possible with attached devices supporting the IEEE 802.3 Clause 28 auto-negotiation standard.

Optical Ports: Ensure that all fiber-optic link ports operate at 1310 or 1550 nanometers in single mode. Provide Type LC connectors for the optical ports, as specified in the Plans or by the Engineer. Do not use mechanical transfer registered jack (MTRJ) type connectors.

Provide an edge switch having a minimum of two optical 100 Base FX ports capable of transmitting data at 100 megabits per second. Ensure that each optical port consists of a pair of fibers; one fiber will transmit (TX) data and one fiber will receive (RX) data. Ensure that the optical ports have an optical power budget of at least 15 dB.

Copper Ports: Provide an edge switch that includes a minimum of four copper ports. Provide Type RJ-45 copper ports that auto-negotiate speed (i.e., 10/100 Base) and duplex (i.e., full or half). Ensure that all 10/100 Base TX ports meet the specifications detailed in this section and are compliant with the IEEE 802.3 standard pinouts. Ensure that all Category 5E unshielded twisted pair/shielded twisted pair network cables are compliant with the EIA/TIA-568-B standard.

Port Security: Ensure that the edge switch supports/complies with the following (remotely) minimum requirements:

- Ability to configure static MAC addresses access;
- Ability to disable automatic address learning per ports; known hereafter as Secure Port. Secure Ports only forward; and
- Trap and alarm upon any unauthorized MAC address and shutdown for programmable duration. Port shutdown requires administrator to manually reset the port before communications are allowed.

E. Management Capabilities:

Ensure that the edge switch supports all Layer 2 management features and certain Layer 3 features related to multicast data transmission and routing. These features shall include, but not be limited to:

- An STP healing/convergence rate that meets or exceeds specifications published in the IEEE 802.1 D standards;
- An RSTP healing/convergence rate that meets or exceeds specifications published in the IEEE 802.1w standard;
- An Ethernet edge switch that is a port-based VLAN and supports VLAN tagging that meets or exceeds specifications as published in the IEEE 802.1Q standard, and has a minimum 4-kilobit VLAN address table (254 simultaneous);
- A forwarding/filtering rate that is a minimum of 14,880 packets per second for 10 megabits per second and 148,800 packets per second for 100 megabits per second;
- A minimum 4-kilobit MAC address table;
- Support of Traffic Class Expediting and Dynamic Multicast Filtering.
- Support of, at a minimum, snooping of Version 2 of the Internet Group Management Protocol (IGMP);

W-5520**TS-45****Union County**

- Support of remote and local setup and management via telnet or secure Web-based GUI and command line interfaces; and
- Support of the Simple Network Management Protocol (SNMP). Verify that the Ethernet edge switch can be accessed using the resident EIA-232 management port, a telecommunication network, or the Trivial File Transfer Protocol (TFTP).

Network Capabilities: Provide an edge switch that supports/complies with the following minimum requirements:

- Provide full implementation of IGMPv2 snooping (RFC 2236);
- Provide full implementation of SNMPv1, SNMPv2c, and/or SNMPv3;
- Provide support for the following RMON–I groups, at a minimum:
 - Part 1: Statistics
 - Part 2: History
 - Part 3: Alarm
 - Part 9: Event
- Capable of mirroring any port to any other port within the switch;
- Meet the IEEE 802.1Q (VLAN) standard per port for up to four VLANs;
- Meet the IEEE 802.3ad (Port Trunking) standard for a minimum of two groups of four ports;
- Password manageable;
- Telnet/CLI;
- HTTP (Embedded Web Server) with Secure Sockets Layer (SSL); and
- Full implementation of RFC 783 (TFTP) to allow remote firmware upgrades.

Network Security: Provide an edge switch that supports/complies with the following (remotely) minimum network security requirements:

- Multi-level user passwords;
- RADIUS centralized password management (IEEE 802.1X);
- SNMPv3 encrypted authentication and access security;
- Port security through controlling access by the users: ensure that the Ethernet edge switch has the capability to generate an alarm and shut down ports when an unauthorized user accesses the network;
- Support of remote monitoring (RMON) of the Ethernet agent; and
- Support of the TFTP and SNTF. Ensure that the Ethernet edge switch supports port mirroring for troubleshooting purposes when combined with a network analyzer.

F. Electrical Specifications:

Ensure that the edge switch operates and power is supplied with 115 volts of alternating current (VAC). Ensure that the edge switch has a minimum operating input of 110 VAC and a maximum operating input of 130 VAC. Ensure that if the device requires operating voltages other than 120 VAC, supply the required voltage converter. Ensure that the maximum power consumption does not exceed 50 watts. Ensure that the edge switch has diagnostic light emitting diodes (LEDs), including link, TX, RX, speed (for Category 5E ports only), and power LEDs.

G. Environmental Specifications:

Ensure that the edge switch performs all of the required functions during and after being subjected to an ambient operating temperature range of -30 degrees to 165 degrees Fahrenheit as

W-5520**TS-46****Union County**

defined in the environmental requirements section of the NEMA TS 2 standard, with a noncondensing humidity of 0 to 95%.

Provide certification that the device has successfully completed environmental testing as defined in the environmental requirements section of the NEMA TS 2 standard. Provide certification that the device meets the vibration and shock resistance requirements of Sections 2.1.9 and 2.1.10, respectively, of the NEMA TS 2 standard. Ensure that the edge switch is protected from rain, dust, corrosive elements, and typical conditions found in a roadside environment.

The edge switch shall meet or exceed the following environmental standards:

- IEEE 1613 (electric utility substations)
- IEC 6185003 (electric utility substations)
- IEEE 61800-3 (variable speed drive systems)
- IEC 61000-6-2 (generic industrial)

H. Ethernet Patch Cable:

Furnish a factory pre-terminated/pre-connectorized Ethernet patch cable with each edge switch. Furnish Ethernet patch cables meeting the following physical requirements:

- Five (5)-foot length
- Category 5e or better
- Factory-installed RJ-45 connectors on both ends
- Molded anti-s snag hoods over connectors
- Gold plated connectors

Furnish Fast Ethernet patch cords meeting the following minimum performance requirements:

- TIA/EIA-568-B-5, Additional Transmission Performance Specifications for 4-pair 100 Ω Enhanced Category 5 Cabling
- Frequency Range: 1-100 MHz
- Near-End Crosstalk (NEXT): 30.1 dB
- Power-sum NEXT: 27.1 dB
- Attenuation to Crosstalk Ratio (ACR): 6.1 dB
- Power-sum ACR: 3.1 dB
- Return Loss: 10dB
- Propagation Delay: 548 nsec

4.3. CONSTRUCTION METHODS

A. General:

Ensure that the edge switch is UL listed.

Verify that network/field/data patch cords meet all ANSI/EIA/TIA requirements for Category 5E and Category 6 four-pair unshielded twisted pair cabling with stranded conductors and RJ45 connectors.

Contact the Division a minimum of 5 days prior to installation for the most current edge switch IP Address, VLAN, subnet mask, default gateway and configuration files.

B. Edge Switch:

Mount the edge switch inside each field cabinet by securely fastening the edge switch to the upper end of the right rear vertical rail of the equipment rack using manufacturer-recommended or Engineer-approved attachment methods, attachment hardware and fasteners. Refer any questions concerning edge switch mounting to the Division.

Ensure that the edge switch is mounted securely in the cabinet and is fully accessible by field technicians without blocking access to other equipment. Verify that fiber-optic jumpers consist of a length of cable that is connectorized on both ends, primarily used for interconnecting termination or patching facilities and/or equipment.

4.4. MEASUREMENT AND PAYMENT

Ethernet edge switch will be measured and paid as the actual number of Ethernet edge switches furnished, installed, and accepted.

No separate measurement will be made for Ethernet patch cable(s), power cord, mounting hardware, nuts, bolts, brackets, or edge switch programming as these will be considered incidental to furnishing and installing the edge switch.

Payment will be made under:

| Pay Item | Pay Unit |
|---------------------------|-----------------|
| Ethernet Edge Switch..... | Each |

5. SPREAD SPECTRUM RADIO

5.1.DESCRPTION

Furnish and install a spread spectrum radio system (900 MHz Serial/Ethernet) with all necessary hardware and signage in accordance with the plans and specifications to provide a data link between field devices (i.e. traffic signal controllers, dynamic message signs etc.). Provide a radio system with a bi-directional, full duplex communications channel between 2 “line-of-sight” antennas using license free, spread spectrum technology operating in the 902-928 MHz frequency band.

5.2.MATERIAL

A. General

Furnish 900 MHz Serial/Ethernet spread spectrum radio systems with field set-up software and all necessary hardware and signage in accordance with the plans and specifications to provide a data link between field devices (i.e. Traffic Signal Controllers, Dynamic Message Signs, etc.).

Provide a radio system with license free 902 – 928 MHz Serial Spread Spectrum transceivers that are capable of Bi-Directional, Full Duplex communications.

Furnish material conforming to the National Electrical Code (NEC), the National Electrical Safety Code (NESC), Underwriter’s Laboratories (UL) or a third-party listing agency accredited by the North Carolina Department of Insurance, and all local safety codes in effect on the date of advertisement. Comply with all regulations and codes imposed by the owner of affected utility poles.

B. 900 MHz Serial/Ethernet Spread Spectrum Radio

Furnish 902 – 928 MHz Serial/Ethernet Spread Spectrum Radios that comply with Table 1098.5:

TABLE 1098.5

| | |
|--------------------------------|------------------------------------------------------------------------------------------------------------------------------------------------------------------------------------------------------------------------------------------------------------------------------------------------------------------------------------------------------------------------------------------------------------------------------------------------------------------------|
| Frequency Range | 902 – 928 MHz |
| Technology | Frequency Hopping Spread Spectrum |
| Operational Modes | master; repeater; repeater/slave; slave; point-to-point; point-to-multipoint; peer-to-peer |
| Operating Voltage | Power Cube: 6 – 30 VDC |
| Operating Temperature/Humidity | -40°C to +75°C; 0 to 95% non-condensing |
| Transmitter | |
| Output Power | 1Watt (Max) |
| Modulation | Frequency Shift Keying |
| Hopping Patterns /Channels | <i>Minimum of 15/Minimum of 25</i> |
| Occupied Bandwidth | 402.8 kHz |
| Data Rate (over the air) | 867Kbps |
| Receiver | |
| Sensitivity | -100 dBm @ 10 ⁻⁶ BER @ 614Kbps OR -100 dBm @ 10 ⁻⁴ BER @ 1.1 Mbps |
| Date Transmission | |
| Error Detection | 32 Bit CRC, retransmit on error |
| Data Encryption | 128-bit |
| Authentication | Radius Compliant |
| System Gain | 130 dB |
| LED's | |
| Signal Strength Indicators | Data Port Indicators consisting of a minimum of 3 LED's grouped together representing a Low, Medium or High Signal Strength with regards to the communications link with another targeted radio. Units must be supplied with external labels to identify how to interpret the Signal Strength. OR Combinations of the Front Panel LED indications with flashing rates and LED Colors can be used to identify the signal strength. Units must be supplied |

W-5520**TS-49****Union County**

| | |
|--------------------------------|-------------------------------------------------------------------------------------------------------------------------------------------------------------------------------------------------------------------------------|
| | with external labels to identify how to interpret the Signal Strength. |
| Front Panel Indicators | Power COM 1 COM 2 OR Carrier Detect Transmit Clear to Send |
| Management & Network Protocols | HTTP, SNMP, Local Console, IP Auto Discover |
| Data Interface | |
| Interface Cable | Type 1 or Type 2 or Type 3 (If not specified in the Plans, furnish a Type 1 Data Interface Cable) |
| Antenna | Threaded Connector (Nickel and/or Silver Plated Brass) |
| Port to Connected Devices | Serial - Dual - DB 9 Female Ports: RS232/422/485 Ethernet: RJ-45 (10/100 BaseT, auto crossover) |
| Network Protocols | IEEE 802.3; HTTP, TCP, UDP, ARP, IMCP, FTP |
| Radio Frequency Signal Jumper | RG-58 coaxial cable (6' long) with one end supplied with RF Threaded Connector that is compatible with the supplied radio. The other end furnished with a Standard N-Type Male Connector to mate with the lightning arrestor. |
| Certification | FCC |

C. Software

Furnish units with a Field Set-up Software. The Field Set-up Software shall be a Window Based™ software program that uses a GUI (Graphical User Interface) to provide the following features at a minimum: remote programming, remote radio configuration, remote maintenance, remote diagnostics and a spectrum analyzer.

Furnish software supplied with drivers to allow easy set-up with all industry standard traffic signal controllers, including 2070L/2070E controllers containing custom software written specifically for the North Carolina Department of Transportation. Manufacturer is required to develop additional drivers (at no charge) for other equipment not supported by their existing pre-written Driver Package when needed. Drivers may be needed for other equipment such as industry standard radar and video detection packages, and Dynamic Message Sign controllers.

W-5520**TS-50****Union County****D. Ethernet Patch Cable for Ethernet Communications:**

When Ethernet communications for the 900 MHz Spread Spectrum Radio is called for on ITS plans, furnish a factory pre-terminated/pre-connectorized Ethernet patch cable with each radio. Furnish Ethernet patch cables meeting the following physical requirements:

- Five (5)-foot length
- Category 5e or better
- Factory-installed RJ-45 connectors on both ends
- Molded anti-snag hoods over connectors
- Gold plated connectors

Furnish Fast Ethernet patch cords meeting the following minimum performance requirements:

- TIA/EIA-568-B-5, Additional Transmission Performance Specifications for 4-pair 100 Ω Enhanced Category 5 Cabling
- Frequency Range: 1-100 MHz
- Near-End Crosstalk (NEXT): 30.1 dB
- Power-sum NEXT: 27.1 dB
- Attenuation to Crosstalk Ratio (ACR): 6.1 dB
- Power-sum ACR: 3.1 dB
- Return Loss: 10dB
- Propagation Delay: 548 nsec

E. Directional Antenna (Yagi)

Furnish a directional antenna of welded construction that allows for vertical and horizontal polarization.

Furnish mounting hardware with the antenna that will secure the antenna to a mounting pipe that has a 1 ½ inch Nominal Pipe Size (approximately 2" OD pipe diameter), as recommended by the manufacturer of the antenna and as approved by the Engineer.

Furnish an 8.5 dBd (11 dBi) Gain or 13 dBd (15.1 dBi) Gain antenna that comply with Table 1098.6 and 1098.7:

TABLE 1098.6 - 900 MHz - Yagi Antenna - (8.5 dBd / 11 dBi Gain)

| Property | Requirement |
|-----------------------------------------------------|---------------------------------------------------------|
| Frequency Range | 896 – 940 MHz |
| Nominal Gain | 8.5 dBd / 11 dBi or |
| Front to Back Ratio | 18 dB |
| Horizontal Beam width (at half power points) | 65 degree |
| Vertical Beam width (at half power points) | 55 degree |
| Power Rating, UHF Frequency | 200 Watts |
| Lightning Protection | DC Ground |
| Termination | Coaxial pigtail with a Standard N-Type Female Connector |
| Impedance | 50Ω |
| Rated Wind Velocity | 125 mph |
| Rated Wind Velocity (with 0.5 inch radial ice) | 100 mph |
| Projected Wind Surface Area (flat plane equivalent) | 0.26 ft/sq. |
| Number Elements | 6 |
| Allows for Vertical or Horizontal polarization | YES |
| Welded construction | YES |

TABLE 1098.7 - 900 MHz - Yagi Antenna – (13 dBd / 15.1 dBi Gain)

| Property | Requirement |
|-----------------------------------------------------|---------------------------------------------------------|
| Frequency Range | 902 – 928 MHz |
| Nominal Gain | 13 dBd / 15.1 dBi |
| Front to Back Ratio | 20 dB |
| Horizontal Beam width (at half power points) | 40 degree |
| Vertical Beam width (at half power points) | 35 degree |
| Power Rating, UHF Frequency | 200 Watts |
| Lightning Protection | DC Ground |
| Termination | Coaxial pigtail with a Standard N-Type Female Connector |
| Impedance | 50Ω |
| Length (approx.) | 53” |
| Rated Wind Velocity | 125 mph |
| Rated Wind Velocity (with 0.5 inch radial ice) | 100 mph |
| Projected Wind Surface Area (flat plane equivalent) | 0.46 ft/sq. |
| Number Elements | 13 |
| Allows for Vertical or Horizontal polarization | YES |
| Welded construction | YES |

F. Antenna Mounting Hardware Kit

Furnish an antenna mounting kit to support the antenna when attached to a metal pole, mast arm or wood pole.

Ensure the Antenna Mounting Hardware Kit includes at least one 96" galvanized steel cable with a stainless steel bolt, nut and lock washer assembly on each end. Ensure the pole base plate accepts a 1 1/2" NPT aluminum pipe, and provides a surface that is at least 6 3/4" long x 4 1/4" to provide contact with the pole. Ensure the pole base plate is designed to allow both ends of the 96" galvanized cables to be secured and tightened to the base plate. Provide a 90 degree elbow

W-5520**TS-52****Union County**

with internal threads on both ends to accommodate 1 1/2" NPT aluminum pipes. Provide a 1 1/2" x 18" long aluminum pipe threaded on both ends and a 1 1/2" x 24" aluminum pipe threaded on one end with an end cap.

G. Coaxial Cable

Furnish 400 Series coaxial cable with water blocking properties to provide a link between the antenna and the lightning arrester that comply with Table 1098.10:

TABLE 1098.10

| Property | Requirement |
|-----------------------------------------|--------------------------------------------------------|
| Attenuation (dB per 100 feet) @ 900 MHz | 3.9 dB |
| Power Rating @ 900 Mhz | 0.58 kW |
| Center Conductor | 0.108" Copper Clad Aluminum |
| Dielectric: Cellular PE | 0.285" |
| Shield (approx.) | Aluminum Tape – 0.291" Tinned Copper Braid – 0.320" |
| Jacket | Black UV protected polyethylene |
| Bend Radius | 1" |
| Impedance | 50Ω |
| Capacitance per foot | 23.9 pf/ft |
| Water Blocking | YES |
| Supply Coaxial Cable on 500ft Reel | YES |

H. Standard N-Type Male Connector

Furnish Standard N-Type Male Connector(s) of proper sizing to mate with the 400 series coaxial cable and use a crimping method to secure the connector to the coaxial cable. Furnish a connector that comply with Table 1098.11:

TABLE 1098.11

| Description | Requirement |
|-----------------------|-----------------------------------------------------------|
| Center Contact | Gold Plated Beryllium Copper-(spring loaded – Non-solder) |
| Outer Contact | Silver Plated Brass |
| Body | Silver Plated Brass |
| Crimp Sleeve | Silver Plated Copper |
| Dielectric | Teflon PTFE |
| Water Proofing Sleeve | Adhesive Lined Polyolefin – Heat Shrink |
| Attachment Size | Crimp Size 0.429" (minimum) hex |
| Electrical Property | Requirement |
| Impedance: | 50Ω |
| Working Voltage | 1000 vrms (max) |
| Insertion loss | 0.1 x √ FGHz |
| VSWR | 1.25:1 (max) up to 2.5GHz |

I. Coaxial Cable Shield Grounding and Weatherproofing Kits

- (a) Furnish a Coaxial Cable Shield Grounding Kit containing components that will adequately bond and ground the cable shield to the pole ground. Ensure the grounding kit complies with MIL-STD-188-124A for coaxial cable and protects the cable from lightning currents of at least 200kA. Ensure each kit is supplied, as a minimum, with the following:
- (i) Preformed Strap: 24 Gauge copper strap that is at least 1 5/8" long and is sized to mate with the 400 series coaxial cable
 - (ii) Tensioning Hardware: Copper nuts and lock washers
 - (iii) Grounding Lead Cable: #6 AWG, stranded, insulated copper wire
- (b) Furnish a Weatherproofing Kit containing components that will protect the coaxial cable shield grounding system against the ingress of moisture and prevent vibrations from loosening the connections. Ensure the weatherproofing kit is supplied, as a minimum, with the following:
- (i) Butyl Mastic Tape: 3 3/4" wide by 24" long (approximately)
 - (ii) Electrical Tape: 2" wide by 20" long (approximately)

J. Lightning Arrestor

Furnish a lightning arrestor installed in line between each antenna and its designated radio modem inside the equipment cabinet in accordance with Table 1098.12. Furnish lightning arrestor with multistrike capability, low strike throughput energy, flange mount and bulkhead mount options and a standard N-Type female connector on both the surge-side and protected-side connectors.

TABLE 1098.12

| Electrical Property | Requirement |
|--------------------------------------------------------------------|-------------------------------------------------------|
| Surge (8/20 μ s Waveform) Maximum Strike Multiple Strike | 40kA Max 20kA Multiple |
| Frequency Range | 698MHz to 2.7GHz |
| Return Loss/VSWR | ≤ -26 dB (VSWR $\leq 1.11:1$) |
| Insertion Loss | ≤ 0.1 dB over frequency range |
| Continuous Power | 500 w @ 920MHz (750 W @ at 122° F) |
| Let Through Voltage | $\leq \pm 200$ mVolts for 3kA @ 8/20 μ s Waveform |

W-5520**TS-54****Union County**

| | |
|----------------------------------|------------------------------------------------------|
| Throughput Energy | ≤ 0.5 nJ for 3kA @ 8/20 μs Waveform |
| Temperature | -40 to 185° F Storage/Operating 122° F |
| Vibration | 1G at 5 Hz up to 100Hz |
| Unit Impedance | 50Ω |
| Standard N-Type Female Connector | On both the surge side and protected side connectors |
| Installation | Bi-Directional |
| Mounting | Bulkhead bracket with O-Ring, Lock Washer and Nut |

K. Coaxial Cable – Power Divider (Splitter)

Furnish a coaxial cable power divider for repeater radio sites in accordance with Table 1098-13. Ensure the power divider accommodates a single primary input RF source and divides/splits the signal (power) equally between 2 output ports.

TABLE 1098.13

| Property | Requirement |
|---------------------------|------------------------|
| Power Division | 2 – Way |
| Frequency | 900 – 1100 MHz |
| Insertion Loss | 0.22 dB |
| Impedance | 50Ω |
| VSWR ref. to 50 Ohm (max) | 1.3:1 |
| Max. Input Power | 500 Watts |
| Connectors | Standard N-Type Female |

L. Disconnect Switch

Furnish a double pole, single throw snap switch in a weatherproof outlet box with cover, suitable for use in wet locations. Ensure outlet box and cover supports a lockout tag device. Ensure outlet box includes one 1/2" diameter hole in back of box. Furnish mounting hardware, sealing gaskets and lockout tag.

M. Warning Signs and Decal

Furnish “RF Warning Sign” and “Decal” at locations called for in the plans. Furnish mounting hardware to secure the sign to either metal or wood poles.

5.3. CONSTRUCTION METHODS**A. General**

For 900 MHz Serial/Ethernet radios install an Ethernet cable, radio frequency signal jumper, lightning arrestor, coaxial cable, coaxial cable shield grounding and weatherproofing kit, antenna and antenna mounting hardware. If the installation requires a dual antenna configuration to accommodate communications in multiple directions install a power divider/splitter, antenna splitter cables and additional antenna and mounting hardware.

Install the antenna in such a manner that avoids conflicts with other utilities (separation distances in accordance with the guidelines of the NESC) and as specified in the antenna manufacturer's recommendations. Secure the antenna mounting hardware to the pole and route the coaxial cable such that no strain is placed on the N-Type male coaxial connectors. On wood pole installations, bond the antenna mounting hardware to the pole ground using #6 AWG bare copper wire using split bolt or compression type fitting.

Install the coaxial cable shield grounding system by carefully removing the outer jacket of the coaxial cable without damaging the cable shield. Install the shield grounding system following the cable manufacturer's recommendations. Install and weatherproof the connection using the appropriate weatherproofing materials and following the manufacturer's recommendations. On wood poles, secure the #6 AWG grounding lead cable to the pole ground using split bolt or compression type fitting or a method approved by the Engineer. On metal poles, secure the #6 AWG grounding lead cable to the pole using a method approved by the Engineer.

Do not exceed the one inch bend radius of the coaxial cable as it traverses from the cabinet to the antenna assembly. Connect the lightning arrestor to the coaxial cable in the equipment cabinet. Properly ground and secure the arrestor in the cabinet. Permanently label all cables entering the cabinet. Ensure the power supply for the radio system is not connected to the GFCI receptacle circuit located in the cabinet. Place a copy of all manufacturer equipment specifications and instruction and maintenance manuals in the equipment cabinet.

At certain locations it may be necessary to integrate the radio system with a fiber optic system. Follow the details shown in the fiber optic splice plans.

At certain locations, the plans may indicate that the existing antenna(s) may be utilized. Utilize the existing antenna and all equipment between the new radio modem and existing antenna as possible. Realign antenna(s) if necessary for proper operation in the new wireless system.

B. Disconnect Switch

At all locations, where the antenna is mounted on a joint use pole, install a double pole, snap switch to remove power from the spread spectrum radio system. Do not mount weatherproof box on the traffic signal cabinet door. Drill a hole in the side of the traffic signal cabinet. Mount the outlet box over the hole using a half inch chase nipple and bushings. Ensure sealing gaskets are in place and no water can enter the cabinet. Securely mount the weatherproof outlet box with additional mounting screws. Bond the outlet box to the equipment ground bus. See plans for approximate mounting height. Run the power supply cord of the spread spectrum radio unit into the outlet box and connect to switch. Securely attach power supply cord to equipment rack. Install disconnect switch with lockout tag cover. If the antenna is mounted on a joint use pole, the "disconnect switch" is required.

Do not install power supply for the radio in a GFCI protected outlet.

C. Warning Sign(s) and Decal(s)

At all locations, where the antenna is mounted on a joint use pole, secure a warning sign to pole. Mount warning sign(s) at locations called for in the plans. Ensure there are no conflicts between the warning sign and surrounding utilities. Mount warning sign to be easily viewed.

W-5520**TS-56****Union County**

Do not mount warning sign under pole grounds or conduit. If the antenna is mounted on a joint use pole, the RF warning sign is required.

Clean and remove any dirt or oil on traffic cabinet before placing decal. Place decal adjacent to the disconnect switch located on the outside of traffic cabinet. If the antenna is mounted on a joint use pole, the decal is required

5.4. MEASUREMENT AND PAYMENT

900 MHz Serial/Ethernet Spread Spectrum Radio will be measured and paid as the actual number of 900 MHz serial/Ethernet spread spectrum radios systems furnished, installed and accepted. This item includes the appropriate sized antenna(s), radio, power supplies, disconnect/snap switch, signs, decals, Ethernet cable, coaxial cable, lightning arrestor, radio frequency signal jumper, coaxial cable power divider (splitter), coaxial cable connectors, coaxial cable shield grounding system with weatherproofing, labeling and any integration between the radio system and a Ethernet switch if necessary, installation materials and configuration software necessary to complete this work, including the warranties.

900 MHz Serial/Ethernet Radio, Using Existing Antenna(s) will be measured and paid as the actual number of 900 MHz serial/Ethernet spread spectrum radios, that utilized existing antenna(s), that have been furnished, installed and accepted. This item includes incorporating the existing antenna(s) with any adjustments and realignment necessary for a functional system, lightning arrestor, signs, decals, coaxial cable power divider (splitter), coaxial cable connectors, coaxial cable shield grounding system with weatherproofing, coaxial cable, and radio frequency signal jumper with the new radio, power supplies, disconnect/snap switch, Ethernet cable, labeling and any integration between the radio system and a Ethernet switch if necessary, installation materials and configuration software necessary to complete this work, including the warranties.

Payment will be made under:

| Pay Item | Pay Unit |
|----------------------------------------------------------|-----------------|
| 900 MHz Serial/Ethernet Spread Spectrum Radio | Each |
| 900 MHz Serial/Ethernet Radio, Using Existing Antenna(s) | Each |

County : Union

| Line # | Item Number | Sec # | Description | Quantity | Unit Cost | Amount |
|----------------------|--------------|-------|----------------------------------------------------|-------------|-----------|--------|
| ROADWAY ITEMS | | | | | | |
| 0001 | 0000100000-N | 800 | MOBILIZATION | Lump Sum | L.S. | |
| 0002 | 0000400000-N | 801 | CONSTRUCTION SURVEYING | Lump Sum | L.S. | |
| 0003 | 0043000000-N | 226 | GRADING | Lump Sum | L.S. | |
| 0004 | 0050000000-E | 226 | SUPPLEMENTARY CLEARING & GRUB-BING | 1 ACR | | |
| 0005 | 0057000000-E | 226 | UNDERCUT EXCAVATION | 2,017 CY | | |
| 0006 | 0134000000-E | 240 | DRAINAGE DITCH EXCAVATION | 120 CY | | |
| 0007 | 0196000000-E | 270 | GEOTEXTILE FOR SOIL STABILIZATION | 400 SY | | |
| 0008 | 0199000000-E | SP | TEMPORARY SHORING | 576 SF | | |
| 0009 | 0318000000-E | 300 | FOUNDATION CONDITIONING MATERIAL, MINOR STRUCTURES | 960 TON | | |
| 0010 | 0320000000-E | 300 | FOUNDATION CONDITIONING GEOTEXTILE | 2,970 SY | | |
| 0011 | 0343000000-E | 310 | 15" SIDE DRAIN PIPE | 442 LF | | |
| 0012 | 0344000000-E | 310 | 18" SIDE DRAIN PIPE | 40 LF | | |
| 0013 | 0366000000-E | 310 | 15" RC PIPE CULVERTS, CLASS III | 540 LF | | |
| 0014 | 0384000000-E | 310 | 30" RC PIPE CULVERTS, CLASS III | 32 LF | | |
| 0015 | 0390000000-E | 310 | 36" RC PIPE CULVERTS, CLASS III | 440 LF | | |
| 0016 | 0448200000-E | 310 | 15" RC PIPE CULVERTS, CLASS IV | 6,004 LF | | |
| 0017 | 0448300000-E | 310 | 18" RC PIPE CULVERTS, CLASS IV | 688 LF | | |
| 0018 | 0448500000-E | 310 | 30" RC PIPE CULVERTS, CLASS IV | 8 LF | | |

County : Union

| Line # | Item Number | Sec # | Description | Quantity | Unit Cost | Amount |
|--------|--------------|-------|-----------------------------------------------------------------------------|----------|-----------|--------|
| 0019 | 0576000000-E | 310 | *** CS PIPE CULVERTS, ***** THICK (15", 0.064") | 110 | LF | |
| 0020 | 0636000000-E | 310 | *** CS PIPE ELBOWS, ***** THICK (15", 0.064") | 6 | EA | |
| 0021 | 0973100000-E | 330 | *** WELDED STEEL PIPE, ***** THICK, GRADE B IN SOIL (15", 0.250") | 43 | LF | |
| 0022 | 0973100000-E | 330 | *** WELDED STEEL PIPE, ***** THICK, GRADE B IN SOIL (18", 0.250") | 32 | LF | |
| 0023 | 0973100000-E | 330 | *** WELDED STEEL PIPE, ***** THICK, GRADE B IN SOIL (42", 0.625") | 68 | LF | |
| 0024 | 0973300000-E | 330 | *** WELDED STEEL PIPE, ***** THICK, GRADE B NOT IN SOIL (15", 0.250") | 43 | LF | |
| 0025 | 0973300000-E | 330 | *** WELDED STEEL PIPE, ***** THICK, GRADE B NOT IN SOIL (18", 0.250") | 32 | LF | |
| 0026 | 0973300000-E | 330 | *** WELDED STEEL PIPE, ***** THICK, GRADE B NOT IN SOIL (42", 0.625") | 68 | LF | |
| 0027 | 0995000000-E | 340 | PIPE REMOVAL | 2,251 | LF | |
| 0028 | 1099500000-E | 505 | SHALLOW UNDERCUT | 200 | CY | |
| 0029 | 1099700000-E | 505 | CLASS IV SUBGRADE STABILIZA- TION | 300 | TON | |
| 0030 | 1220000000-E | 545 | INCIDENTAL STONE BASE | 1,000 | TON | |
| 0031 | 1297000000-E | 607 | MILLING ASPHALT PAVEMENT, ***** DEPTH (1-1/2") | 12,030 | SY | |
| 0032 | 1330000000-E | 607 | INCIDENTAL MILLING | 4,166 | SY | |
| 0033 | 1491000000-E | 610 | ASPHALT CONC BASE COURSE, TYPE B25.0C | 16,300 | TON | |

County : Union

| Line # | Item Number | Sec # | Description | Quantity | Unit Cost | Amount |
|--------|--------------|-------|--------------------------------------------------|----------|-----------|--------|
| 0034 | 1503000000-E | 610 | ASPHALT CONC INTERMEDIATE COURSE, TYPE I19.0C | 6,670 | TON | |
| 0035 | 1523000000-E | 610 | ASPHALT CONC SURFACE COURSE, TYPE S9.5C | 14,860 | TON | |
| 0036 | 1525000000-E | 610 | ASPHALT CONC SURFACE COURSE, TYPE SF9.5A | 60 | TON | |
| 0037 | 1575000000-E | 620 | ASPHALT BINDER FOR PLANT MIX | 1,920 | TON | |
| 0038 | 1693000000-E | 654 | ASPHALT PLANT MIX, PAVEMENT REPAIR | 670 | TON | |
| 0039 | 1891000000-E | SP | GENERIC PAVING ITEM VARIABLE DEPTH MILLING | 25,000 | SY | |
| 0040 | 2209000000-E | 838 | ENDWALLS | 7.204 | CY | |
| 0041 | 2253000000-E | 840 | PIPE COLLARS | 2.604 | CY | |
| 0042 | 2264000000-E | 840 | PIPE PLUGS | 0.045 | CY | |
| 0043 | 2275000000-E | SP | FLOWABLE FILL | 23 | CY | |
| 0044 | 2286000000-N | 840 | MASONRY DRAINAGE STRUCTURES | 135 | EA | |
| 0045 | 2297000000-E | 840 | MASONRY DRAINAGE STRUCTURES | 9.6 | CY | |
| 0046 | 2308000000-E | 840 | MASONRY DRAINAGE STRUCTURES | 15.7 | LF | |
| 0047 | 2364000000-N | 840 | FRAME WITH TWO GRATES, STD 840.16 | 73 | EA | |
| 0048 | 2364200000-N | 840 | FRAME WITH TWO GRATES, STD 840.20 | 2 | EA | |
| 0049 | 2365000000-N | 840 | FRAME WITH TWO GRATES, STD 840.22 | 19 | EA | |
| 0050 | 2374000000-N | 840 | FRAME WITH GRATE & HOOD, STD 840.03, TYPE ** (F) | 18 | EA | |

County : Union

| Line # | Item Number | Sec # | Description | Quantity | Unit Cost | Amount |
|--------|--------------|-------|----------------------------------------------------------|----------|-----------|--------|
| 0051 | 2374000000-N | 840 | FRAME WITH GRATE & HOOD, STD 840.03, TYPE ** (G) | 16 | EA | |
| 0052 | 2396000000-N | 840 | FRAME WITH COVER, STD 840.54 | 12 | EA | |
| 0053 | 2451000000-N | 852 | CONCRETE TRANSITIONAL SECTION FOR DROP INLET | 71 | EA | |
| 0054 | 2542000000-E | 846 | 1'-6" CONCRETE CURB & GUTTER | 280 | LF | |
| 0055 | 2549000000-E | 846 | 2'-6" CONCRETE CURB & GUTTER | 6,780 | LF | |
| 0056 | 2591000000-E | 848 | 4" CONCRETE SIDEWALK | 450 | SY | |
| 0057 | 2605000000-N | 848 | CONCRETE CURB RAMP | 8 | EA | |
| 0058 | 2627000000-E | 852 | 4" CONCRETE ISLAND COVER | 1,910 | SY | |
| 0059 | 2647000000-E | 852 | 5" MONOLITHIC CONCRETE ISLANDS (SURFACE MOUNTED) | 420 | SY | |
| 0060 | 2655000000-E | 852 | 5" MONOLITHIC CONCRETE ISLANDS (KEYED IN) | 3,160 | SY | |
| 0061 | 2657000000-E | 852 | *** MONOLITHIC CONCRETE MEDIAN (****) (7", KEYED IN) | 3 | SY | |
| 0062 | 2759000000-N | SP | GENERIC PAVING ITEM EMERGENCY VEHICLE ACCESS | 4 | EA | |
| 0063 | 2815000000-N | 858 | ADJUSTMENT OF DROP INLETS | 2 | EA | |
| 0064 | 2905000000-N | 859 | CONVERT EXISTING DROP INLET TO JUNCTION BOX | 1 | EA | |
| 0065 | 2938000000-N | 859 | CONVERT EXISTING DROP INLET TO JUNCTION BOX WITH MANHOLE | 4 | EA | |
| 0066 | 3030000000-E | 862 | STEEL BM GUARDRAIL | 150 | LF | |
| 0067 | 3045000000-E | 862 | STEEL BM GUARDRAIL, SHOP CURVED | 50 | LF | |

County : Union

| Line # | Item Number | Sec # | Description | Quantity | Unit Cost | Amount |
|--------|--------------|-------|----------------------------------------------------------------------|-------------|-----------|--------|
| 0068 | 3210000000-N | 862 | GUARDRAIL ANCHOR UNITS, TYPE CAT-1 | 2 EA | | |
| 0069 | 3435000000-N | SP | GENERIC GUARDRAIL ITEM EXTRA LENGTH GUARDRAIL POSTS (8' STEEL) | 5 EA | | |
| 0070 | 3628000000-E | 876 | RIP RAP, CLASS I | 30 TON | | |
| 0071 | 3635000000-E | 876 | RIP RAP, CLASS II | 60 TON | | |
| 0072 | 3649000000-E | 876 | RIP RAP, CLASS B | 25 TON | | |
| 0073 | 3656000000-E | 876 | GEOTEXTILE FOR DRAINAGE | 215 SY | | |
| 0074 | 4072000000-E | 903 | SUPPORTS, 3-LB STEEL U-CHANNEL | 3,221 LF | | |
| 0075 | 4102000000-N | 904 | SIGN ERECTION, TYPE E | 158 EA | | |
| 0076 | 4108000000-N | 904 | SIGN ERECTION, TYPE F | 23 EA | | |
| 0077 | 4109000000-N | 904 | SIGN ERECTION, TYPE *** (OVER- HEAD) (B) | 9 EA | | |
| 0078 | 4116100000-N | 904 | SIGN ERECTION, RELOCATE, TYPE **** (GROUND MOUNTED) (D) | 1 EA | | |
| 0079 | 4155000000-N | 907 | DISPOSAL OF SIGN SYSTEM, U- CHANNEL | 44 EA | | |
| 0080 | 4192000000-N | 907 | DISPOSAL OF SUPPORT, U-CHANNEL | 1 EA | | |
| 0081 | 4400000000-E | 1110 | WORK ZONE SIGNS (STATIONARY) | 444 SF | | |
| 0082 | 4410000000-E | 1110 | WORK ZONE SIGNS (BARRICADE MOUNTED) | 70 SF | | |
| 0083 | 4420000000-N | 1120 | PORTABLE CHANGEABLE MESSAGE SIGN | 7 EA | | |
| 0084 | 4430000000-N | 1130 | DRUMS | 1,170 EA | | |
| 0085 | 4445000000-E | 1145 | BARRICADES (TYPE III) | 92 LF | | |

County : Union

| Line # | Item Number | Sec # | Description | Quantity | Unit Cost | Amount |
|--------|--------------|-------|----------------------------------------------------------------------|----------|-----------|--------|
| 0086 | 4465000000-N | 1160 | TEMPORARY CRASH CUSHIONS | 2 | EA | |
| 0087 | 4490000000-E | 1170 | PORTABLE CONCRETE BARRIER (ANCHORED) | 670 | LF | |
| 0088 | 4510000000-N | SP | LAW ENFORCEMENT | 96 | HR | |
| 0089 | 4650000000-N | 1251 | TEMPORARY RAISED PAVEMENT MARKERS | 345 | EA | |
| 0090 | 4685000000-E | 1205 | THERMOPLASTIC PAVEMENT MARKING LINES (4", 90 MILS) | 48,785 | LF | |
| 0091 | 4686000000-E | 1205 | THERMOPLASTIC PAVEMENT MARKING LINES (4", 120 MILS) | 18,260 | LF | |
| 0092 | 4695000000-E | 1205 | THERMOPLASTIC PAVEMENT MARKING LINES (8", 90 MILS) | 9,701 | LF | |
| 0093 | 4697000000-E | 1205 | THERMOPLASTIC PAVEMENT MARKING LINES (8", 120 MILS) | 4,223 | LF | |
| 0094 | 4700000000-E | 1205 | THERMOPLASTIC PAVEMENT MARKING LINES (12", 90 MILS) | 1,007 | LF | |
| 0095 | 4710000000-E | 1205 | THERMOPLASTIC PAVEMENT MARKING LINES (24", 120 MILS) | 2,892 | LF | |
| 0096 | 4721000000-E | 1205 | THERMOPLASTIC PAVEMENT MARKING CHARACTER (120 MILS) | 110 | EA | |
| 0097 | 4725000000-E | 1205 | THERMOPLASTIC PAVEMENT MARKING SYMBOL (90 MILS) | 307 | EA | |
| 0098 | 4770000000-E | 1205 | COLD APPLIED PLASTIC PAVEMENT MARKING LINES, TYPE ** (4") (II) | 550 | LF | |
| 0099 | 4805000000-N | 1205 | COLD APPLIED PLASTIC PAVEMENT MARKING SYMBOL, TYPE ** (II) | 2 | EA | |
| 0100 | 4810000000-E | 1205 | PAINT PAVEMENT MARKING LINES (4") | 26,347 | LF | |
| 0101 | 4820000000-E | 1205 | PAINT PAVEMENT MARKING LINES (8") | 5,188 | LF | |

County : Union

| Line # | Item Number | Sec # | Description | Quantity | Unit Cost | Amount |
|--------|--------------|-------|--------------------------------------------------------|----------|-----------|--------|
| 0102 | 4835000000-E | 1205 | PAINT PAVEMENT MARKING LINES (24") | 643 | LF | |
| 0103 | 4840000000-N | 1205 | PAINT PAVEMENT MARKING CHARAC- TER | 24 | EA | |
| 0104 | 4845000000-N | 1205 | PAINT PAVEMENT MARKING SYMBOL | 91 | EA | |
| 0105 | 4895000000-N | SP | GENERIC PAVEMENT MARKING ITEM IN LANE ROUTE SHIELDS | 6 | EA | |
| 0106 | 4900000000-N | 1251 | PERMANENT RAISED PAVEMENT MARKERS | 1,530 | EA | |
| 0107 | 5255000000-N | 1413 | PORTABLE LIGHTING | Lump Sum | L.S. | |
| 0108 | 5325200000-E | 1510 | 2" WATER LINE | 417 | LF | |
| 0109 | 5325600000-E | 1510 | 6" WATER LINE | 163 | LF | |
| 0110 | 5326600000-E | 1510 | 16" WATER LINE | 429 | LF | |
| 0111 | 5329000000-E | SP | DUCTILE IRON WATER PIPE FITTINGS | 4,300 | LB | |
| 0112 | 5536000000-E | 1515 | 2" VALVE | 1 | EA | |
| 0113 | 5648000000-N | 1515 | RELOCATE WATER METER | 11 | EA | |
| 0114 | 5649000000-N | 1515 | RECONNECT WATER METER | 3 | EA | |
| 0115 | 5672000000-N | 1515 | RELOCATE FIRE HYDRANT | 1 | EA | |
| 0116 | 5685200000-E | 1515 | 16" LINE STOP WITH BYPASS | 4 | EA | |
| 0117 | 5800000000-E | 1530 | ABANDON 6" UTILITY PIPE | 160 | LF | |
| 0118 | 5810000000-E | 1530 | ABANDON 16" UTILITY PIPE | 425 | LF | |
| 0119 | 6000000000-E | 1605 | TEMPORARY SILT FENCE | 6,315 | LF | |
| 0120 | 6006000000-E | 1610 | STONE FOR EROSION CONTROL, CLASS A | 125 | TON | |

County : Union

| Line # | Item Number | Sec # | Description | Quantity | Unit Cost | Amount |
|--------|--------------|-------|---------------------------------------|--------------|-----------|--------|
| 0121 | 6009000000-E | 1610 | STONE FOR EROSION CONTROL, CLASS B | 225 TON | | |
| 0122 | 6012000000-E | 1610 | SEDIMENT CONTROL STONE | 220 TON | | |
| 0123 | 6015000000-E | 1615 | TEMPORARY MULCHING | 7.5 ACR | | |
| 0124 | 6018000000-E | 1620 | SEED FOR TEMPORARY SEEDING | 400 LB | | |
| 0125 | 6021000000-E | 1620 | FERTILIZER FOR TEMPORARY SEED- ING | 2 TON | | |
| 0126 | 6024000000-E | 1622 | TEMPORARY SLOPE DRAINS | 200 LF | | |
| 0127 | 6029000000-E | SP | SAFETY FENCE | 200 LF | | |
| 0128 | 6030000000-E | 1630 | SILT EXCAVATION | 400 CY | | |
| 0129 | 6036000000-E | 1631 | MATTING FOR EROSION CONTROL | 29,900 SY | | |
| 0130 | 6037000000-E | SP | COIR FIBER MAT | 100 SY | | |
| 0131 | 6038000000-E | SP | PERMANENT SOIL REINFORCEMENT MAT | 350 SY | | |
| 0132 | 6042000000-E | 1632 | 1/4" HARDWARE CLOTH | 300 LF | | |
| 0133 | 6071010000-E | SP | WATTLE | 4,960 LF | | |
| 0134 | 6071020000-E | SP | POLYACRYLAMIDE (PAM) | 50 LB | | |
| 0135 | 6071030000-E | 1640 | COIR FIBER BAFFLE | 100 LF | | |
| 0136 | 6084000000-E | 1660 | SEEDING & MULCHING | 9 ACR | | |
| 0137 | 6087000000-E | 1660 | MOWING | 6 ACR | | |
| 0138 | 6090000000-E | 1661 | SEED FOR REPAIR SEEDING | 100 LB | | |
| 0139 | 6093000000-E | 1661 | FERTILIZER FOR REPAIR SEEDING | 0.25 TON | | |
| 0140 | 6096000000-E | 1662 | SEED FOR SUPPLEMENTAL SEEDING | 175 LB | | |

County : Union

| Line # | Item Number | Sec # | Description | Quantity | Unit Cost | Amount |
|--------|--------------|-------|------------------------------------------------------------|----------|-----------|--------|
| 0141 | 6108000000-E | 1665 | FERTILIZER TOPDRESSING | 4.75 | TON | |
| 0142 | 6114500000-N | 1667 | SPECIALIZED HAND MOWING | 10 | MHR | |
| 0143 | 6117000000-N | SP | RESPONSE FOR EROSION CONTROL | 75 | EA | |
| 0144 | 6132000000-N | SP | GENERIC EROSION CONTROL ITEM CONCRETE WASHOUT STRUCTURE | 2 | EA | |
| 0145 | 7048500000-E | 1705 | PEDESTRIAN SIGNAL HEAD (16", 1 SECTION W/COUNTDOWN) | 18 | EA | |
| 0146 | 7060000000-E | 1705 | SIGNAL CABLE | 12,180 | LF | |
| 0147 | 7120000000-E | 1705 | VEHICLE SIGNAL HEAD (12", 3 SECTION) | 64 | EA | |
| 0148 | 7132000000-E | 1705 | VEHICLE SIGNAL HEAD (12", 4 SECTION) | 12 | EA | |
| 0149 | 7252000000-E | 1710 | MESSENGER CABLE (1/4") | 170 | LF | |
| 0150 | 7264000000-E | 1710 | MESSENGER CABLE (3/8") | 5,480 | LF | |
| 0151 | 7288000000-E | 1715 | PAVED TRENCHING (***** (1, 2") | 50 | LF | |
| 0152 | 7288000000-E | 1715 | PAVED TRENCHING (***** (2, 2") | 70 | LF | |
| 0153 | 7300000000-E | 1715 | UNPAVED TRENCHING (***** (1, 2") | 9,050 | LF | |
| 0154 | 7300000000-E | 1715 | UNPAVED TRENCHING (***** (2, 2") | 200 | LF | |
| 0155 | 7300000000-E | 1715 | UNPAVED TRENCHING (***** (3, 2") | 570 | LF | |
| 0156 | 7300000000-E | 1715 | UNPAVED TRENCHING (***** (5, 2") | 140 | LF | |
| 0157 | 7300000000-E | 1715 | UNPAVED TRENCHING (***** (6, 2") | 10 | LF | |

County : Union

| Line # | Item Number | Sec # | Description | Quantity | Unit Cost | Amount |
|--------|--------------|-------|-------------------------------------------------------|--------------|-----------|--------|
| 0158 | 7300000000-E | 1715 | UNPAVED TRENCHING (***** (7, 2") | 40 LF | | |
| 0159 | 7300100000-E | 1715 | UNPAVED TRENCHING FOR TEMP- ORARY LEAD-IN | 90 LF | | |
| 0160 | 7301000000-E | 1715 | DIRECTIONAL DRILL (***** (2, 2") | 1,360 LF | | |
| 0161 | 7324000000-N | 1716 | JUNCTION BOX (STANDARD SIZE) | 123 EA | | |
| 0162 | 7348000000-N | 1716 | JUNCTION BOX (OVER-SIZED, HEA- VY DUTY) | 16 EA | | |
| 0163 | 7360000000-N | 1720 | WOOD POLE | 42 EA | | |
| 0164 | 7372000000-N | 1721 | GUY ASSEMBLY | 64 EA | | |
| 0165 | 7408000000-E | 1722 | 1" RISER WITH WEATHERHEAD | 7 EA | | |
| 0166 | 7420000000-E | 1722 | 2" RISER WITH WEATHERHEAD | 56 EA | | |
| 0167 | 7432000000-E | 1722 | 2" RISER WITH HEAT SHRINK TUBING | 16 EA | | |
| 0168 | 7444000000-E | 1725 | INDUCTIVE LOOP SAWCUT | 13,680 LF | | |
| 0169 | 7456000000-E | 1726 | LEAD-IN CABLE (***** (14-2) | 41,540 LF | | |
| 0170 | 7636000000-N | 1745 | SIGN FOR SIGNALS | 20 EA | | |
| 0171 | 7642100000-N | 1743 | TYPE I POST WITH FOUNDATION | 4 EA | | |
| 0172 | 7642200000-N | 1743 | TYPE II PEDESTAL WITH FOUND- ATION | 14 EA | | |
| 0173 | 7684000000-N | 1750 | SIGNAL CABINET FOUNDATION | 16 EA | | |
| 0174 | 7686000000-N | 1752 | CONDUIT ENTRANCE INTO EXISTING FOUNDATION | 1 EA | | |
| 0175 | 7756000000-N | 1751 | CONTROLLER WITH CABINET (TYPE 2070L, BASE MOUNTED) | 16 EA | | |

County : Union

| Line # | Item Number | Sec # | Description | Quantity | Unit Cost | Amount |
|--------|--------------|-------|-------------------------------------------------------------------------------------|----------|-----------|--------|
| 0176 | 7780000000-N | 1751 | DETECTOR CARD (TYPE 2070L) | 66 | | EA |
| 0177 | 7901000000-N | 1753 | CABINET BASE EXTENDER | 16 | | EA |
| 0178 | 7980000000-N | SP | GENERIC SIGNAL ITEM 900 MHZ SERIAL/ETHERNET RADIO, USING EXISTING ANTENNA (S) | 1 | | EA |
| 0179 | 7980000000-N | SP | GENERIC SIGNAL ITEM 900 MHZ SERIAL/ETHERNET SPREAD SPECTRUM RADIO | 16 | | EA |
| 0180 | 7980000000-N | SP | GENERIC SIGNAL ITEM ETHERNET EDGE SWITCH | 19 | | EA |
| 0181 | 7980000000-N | SP | GENERIC SIGNAL ITEM REPLACE CONFLICT MONITOR | 1 | | EA |
| 0182 | 7980000000-N | SP | GENERIC SIGNAL ITEM REPLACE CONTROLLER | 1 | | EA |
| 0183 | 8802040000-E | SP | CIP GRAVITY RETAINING WALLS | 538 | | SF |

1344/Mar10/Q376980.653/D788814300000/E183

Total Amount Of Bid For Entire Project :

DBE GOAL SET: 10.00%
DBE GOAL OBT: 10.00%

Vendor 1 of 2: SEALAND CONTRACTORS CORP (3618)
Call Order 003 (Proposal: C203788)

Bid Information

Proposal County: UNION

Vendor Address: P.O. Box 350
85 High Tech Drive
Rush , NY , 14543-0350

Signature Check: Robert_J._Bree_3618

Time Bid Received: April 18, 2017 01:28 PM

Amendment Count: 0

Bid Checksum: 55AF5D5D

Bid Total: \$9,544,080.09

Items Total: \$9,544,080.09

Time Total: \$0.00

Bidding Errors:

None.

Vendor 1 of 2: SEALAND CONTRACTORS CORP (3618)
Call Order 003 (Proposal: C203788)

Bid Bond Information

| | |
|-----------------------------|--------------------------------------------------------------|
| Projects: | Bond Maximum: |
| Counties: | State of Incorporation: |
| Bond ID: SNC17790817 | Agency Execution Date: 4/6/2017 3 |
| Paid by Check: No | Surety Name: surety2000 |
| Bond Percent: 5% | Bond Agency Name: Liberty Mutual Insurance Company |

Bidder 1 of 2

Vendor 3618's Bid Information for Call 003, Letting L170418, 04/18/17

Sealand Contractors Corp. (3618)
Call Order 003 (Proposal ID C203788)

LIST OF DBE PARTICIPANTS

| VENDOR NUMBER | DBE NAME ADDRESS | WORK CODE TYPE OF WORK | CERT TYPE AMOUNT |
|---------------|----------------------------------------------------------------|------------------------|-------------------------------|
| MB 11238 | BKP TRUCKING LLC 13904 HAVEN RIDGE LN , CHARLOTTE, NC 28215 | | Sub 954,415.00 |
| | | | TOTAL: \$954,415.00 10.00% |

COMMITTED

Vendor 3618's Bid Information for Call 003, Letting L170418, 04/18/17

Sealand Contractors Corp. (3618)
Call Order 003 (Proposal ID C203788)

Miscellaneous Data Info - Contractor Responses:
=====

NON-COLLUSION AND DEBARMENT CERTIFICATION

Explanation of the prospective bidder that is unable to certify to any of the statements in this certification:

Explanation:
NOT ANSWERED
NOT ANSWERED
NOT ANSWERED
NOT ANSWERED

AWARD LIMITS ON MULTIPLE PROJECTS

By answering YES to this statement, the bidder acknowledges that they are using the award limits on multiple projects. No

It is the desire of the Bidder to be awarded contracts, the value of which will not exceed a total of NOT ANSWERED for those projects indicated herein, for which bids will be opened on (MM/DD/YY)

The Award Limits shall apply to the following projects:

| Contract Number | County |
|-----------------|--------|
| NOT ANSWERED | |
| NOT ANSWERED | |
| NOT ANSWERED | |
| NOT ANSWERED | |
| NOT ANSWERED | |
| NOT ANSWERED | |

Bid Bond Data Info - Contractor Responses:
=====

BondID: SNC17790817
Surety Registry Agency: surety2000
Verified?: Yes

Bidder 1 of 2

Surety Agency: Liberty Mutual Insurance Company

Bond Execution Date: 4/6/2017 3

Bond Amount: \$477,204.00 (Five Percent of Bid)

Dept of Transportation

Revised:

Contract ID: C203788

Project(s): HSIP-0074(156)

Letting Date: 04-18-17 Call Order: 003

Bidder: 3618 - Sealand Contractors Corp.

| Line No. | Item Description | Approx. Quantity and Units | Unit Price Dollars Cts | Bid Amount Dollars Ct |
|----------------------------|-----------------------------------------------------------------|----------------------------|--------------------------|-------------------------|
| Section 0001 ROADWAY ITEMS | | | | |
| Alt Group | | | | |
| 0001 | 0000100000-N MOBILIZATION | LUMP | LUMP | 477,000.00 |
| 0002 | 0000400000-N CONSTRUCTION SURVEYING | LUMP | LUMP | 100,000.00 |
| 0003 | 0043000000-N GRADING | LUMP | LUMP | 1,255,000.00 |
| 0004 | 0050000000-E SUPPLEMENTARY CLEARING & GRUB-BING | 1.000 ACR | 10,000.00000 | 10,000.00 |
| 0005 | 0057000000-E UNDERCUT EXCAVATION | 2,017.000 CY | 44.00000 | 88,748.00 |
| 0006 | 0134000000-E DRAINAGE DITCH EXCAVATION | 120.000 CY | 15.00000 | 1,800.00 |
| 0007 | 0196000000-E GEOTEXTILE FOR SOIL STABILIZATION | 400.000 SY | 2.00000 | 800.00 |
| 0008 | 0199000000-E TEMPORARY SHORING | 576.000 SF | 89.00000 | 51,264.00 |
| 0009 | 0318000000-E FOUNDATION CONDITIONING MATERIAL, MINOR STRUCTURES | 960.000 TON | 42.00000 | 40,320.00 |
| 0010 | 0320000000-E FOUNDATION CONDITIONING GEOTEXTILE | 2,970.000 SY | 1.00000 | 2,970.00 |
| 0011 | 0343000000-E 15" SIDE DRAIN PIPE | 442.000 LF | 49.00000 | 21,658.00 |

Dept of Transportation

Revised:

Contract ID: C203788

Project(s): HSIP-0074(156)

Letting Date: 04-18-17 Call Order: 003

Bidder: 3618 - Sealand Contractors Corp.

| Line No. | Item Description | Approx. Quantity and Units | Unit Price Dollars Cts | Bid Amount Dollars Ct |
|----------|--------------------------------------------------------------------------------|----------------------------|--------------------------|-------------------------|
| 0012 | 0344000000-E 18" SIDE DRAIN PIPE | 40.000 | 52.00000 | 2,080.00 |
| | | LF | | |
| 0013 | 0366000000-E 15" RC PIPE CULVERTS, CLASS III | 540.000 | 47.00000 | 25,380.00 |
| | | LF | | |
| 0014 | 0384000000-E 30" RC PIPE CULVERTS, CLASS III | 32.000 | 105.00000 | 3,360.00 |
| | | LF | | |
| 0015 | 0390000000-E 36" RC PIPE CULVERTS, CLASS III | 440.000 | 108.00000 | 47,520.00 |
| | | LF | | |
| 0016 | 0448200000-E 15" RC PIPE CULVERTS, CLASS IV | 6,004.000 | 54.00000 | 324,216.00 |
| | | LF | | |
| 0017 | 0448300000-E 18" RC PIPE CULVERTS, CLASS IV | 688.000 | 59.00000 | 40,592.00 |
| | | LF | | |
| 0018 | 0448500000-E 30" RC PIPE CULVERTS, CLASS IV | 8.000 | 200.00000 | 1,600.00 |
| | | LF | | |
| 0019 | 0576000000-E *** CS PIPE CULVERTS, ***** THICK (15", 0.064") | 110.000 | 67.00000 | 7,370.00 |
| | | LF | | |
| 0020 | 0636000000-E *** CS PIPE ELBOWS, ***** THICK (15", 0.064") | 6.000 | 400.00000 | 2,400.00 |
| | | EA | | |
| 0021 | 0973100000-E *** WELDED STEEL PIPE, ***** THICK, GRADE B IN SOIL (15", 0.250") | 43.000 | 215.00000 | 9,245.00 |
| | | LF | | |
| 0022 | 0973100000-E *** WELDED STEEL PIPE, ***** THICK, GRADE B IN SOIL (18", 0.250") | 32.000 | 235.00000 | 7,520.00 |
| | | LF | | |

Contract ID: C203788

Project(s): HSIP-0074(156)

Letting Date: 04-18-17 Call Order: 003

Bidder: 3618 - Sealand Contractors Corp.

| Line No. | Item Description | Approx. Quantity and Units | Unit Price Dollars Cts | Bid Amount Dollars Ct |
|----------|------------------------------------------------------------------------------------|----------------------------|--------------------------|-------------------------|
| 0023 | 0973100000-E *** WELDED STEEL PIPE, ***** THICK, GRADE B IN SOIL (42", 0.625") | 68.000 LF | 515.00000 | 35,020.00 |
| 0024 | 0973300000-E *** WELDED STEEL PIPE, ***** THICK, GRADE B NOT IN SOIL (15", 0.250") | 43.000 LF | 645.00000 | 27,735.00 |
| 0025 | 0973300000-E *** WELDED STEEL PIPE, ***** THICK, GRADE B NOT IN SOIL (18", 0.250") | 32.000 LF | 660.00000 | 21,120.00 |
| 0026 | 0973300000-E *** WELDED STEEL PIPE, ***** THICK, GRADE B NOT IN SOIL (42", 0.625") | 68.000 LF | 1,305.00000 | 88,740.00 |
| 0027 | 0995000000-E PIPE REMOVAL | 2,251.000 LF | 21.00000 | 47,271.00 |
| 0028 | 1099500000-E SHALLOW UNDERCUT | 200.000 CY | 25.00000 | 5,000.00 |
| 0029 | 1099700000-E CLASS IV SUBGRADE STABILIZATION | 300.000 TON | 32.00000 | 9,600.00 |
| 0030 | 1220000000-E INCIDENTAL STONE BASE | 1,000.000 TON | 32.00000 | 32,000.00 |
| 0031 | 1297000000-E MILLING ASPHALT PAVEMENT, ***"DEPTH (1-1/2") | 12,030.000 SY | 4.25000 | 51,127.50 |
| 0032 | 1330000000-E INCIDENTAL MILLING | 4,166.000 SY | 10.00000 | 41,660.00 |
| 0033 | 1491000000-E ASPHALT CONC BASE COURSE, TYPE B25.0C | 16,300.000 TON | 69.00000 | 1,124,700.00 |

Dept of Transportation

Revised:

Contract ID: C203788

Project(s): HSIP-0074(156)

Letting Date: 04-18-17 Call Order: 003

Bidder: 3618 - Sealand Contractors Corp.

| Line No. | Item Description | Approx. Quantity and Units | Unit Price Dollars Cts | Bid Amount Dollars Ct |
|----------|------------------------------------------------------------|----------------------------|--------------------------|-------------------------|
| 0034 | 1503000000-E ASPHALT CONC INTERMEDIATE COURSE, TYPE I19.0C | 6,670.000 TON | 69.00000 | 460,230.00 |
| 0035 | 1523000000-E ASPHALT CONC SURFACE COURSE, TYPE S9.5C | 14,860.000 TON | 69.00000 | 1,025,340.00 |
| 0036 | 1525000000-E ASPHALT CONC SURFACE COURSE, TYPE SF9.5A | 60.000 TON | 125.00000 | 7,500.00 |
| 0037 | 1575000000-E ASPHALT BINDER FOR PLANT MIX | 1,920.000 TON | 467.00000 | 896,640.00 |
| 0038 | 1693000000-E ASPHALT PLANT MIX, PAVEMENT REPAIR | 670.000 TON | 185.00000 | 123,950.00 |
| 0039 | 1891000000-E GENERIC PAVING ITEM VARIABLE DEPTH MILLING | 25,000.000 SY | 2.65000 | 66,250.00 |
| 0040 | 2209000000-E ENDWALLS | 7.204 CY | 1,150.00000 | 8,284.60 |
| 0041 | 2253000000-E PIPE COLLARS | 2.604 CY | 1,100.00000 | 2,864.40 |
| 0042 | 2264000000-E PIPE PLUGS | 0.045 CY | 1,250.00000 | 56.25 |
| 0043 | 2275000000-E FLOWABLE FILL | 23.000 CY | 225.00000 | 5,175.00 |
| 0044 | 2286000000-N MASONRY DRAINAGE STRUCTURES | 135.000 EA | 1,700.00000 | 229,500.00 |
| 0045 | 2297000000-E MASONRY DRAINAGE STRUCTURES | 9.600 CY | 2,670.00000 | 25,632.00 |

Contract ID: C203788

Project(s): HSIP-0074(156)

Letting Date: 04-18-17 Call Order: 003

Bidder: 3618 - Sealand Contractors Corp.

| Line No. | Item Description | Approx. Quantity and Units | Unit Price Dollars Cts | Bid Amount Dollars Ct |
|----------|---------------------------------------------------------------|----------------------------|--------------------------|-------------------------|
| 0046 | 2308000000-E MASONRY DRAINAGE STRUCTURES | 15.700 LF | 340.00000 | 5,338.00 |
| 0047 | 2364000000-N FRAME WITH TWO GRATES, STD 840.16 | 73.000 EA | 425.00000 | 31,025.00 |
| 0048 | 2364200000-N FRAME WITH TWO GRATES, STD 840.20 | 2.000 EA | 485.00000 | 970.00 |
| 0049 | 2365000000-N FRAME WITH TWO GRATES, STD 840.22 | 19.000 EA | 485.00000 | 9,215.00 |
| 0050 | 2374000000-N FRAME WITH GRATE & HOOD, STD 840.03, TYPE ** (F) | 18.000 EA | 510.00000 | 9,180.00 |
| 0051 | 2374000000-N FRAME WITH GRATE & HOOD, STD 840.03, TYPE ** (G) | 16.000 EA | 510.00000 | 8,160.00 |
| 0052 | 2396000000-N FRAME WITH COVER, STD 840.54 | 12.000 EA | 300.00000 | 3,600.00 |
| 0053 | 2451000000-N CONCRETE TRANSITIONAL SECTION FOR DROP INLET | 71.000 EA | 725.00000 | 51,475.00 |
| 0054 | 2542000000-E 1'-6" CONCRETE CURB & GUTTER | 280.000 LF | 22.75000 | 6,370.00 |
| 0055 | 2549000000-E 2'-6" CONCRETE CURB & GUTTER | 6,780.000 LF | 23.00000 | 155,940.00 |
| 0056 | 2591000000-E 4" CONCRETE SIDEWALK | 450.000 SY | 40.00000 | 18,000.00 |
| 0057 | 2605000000-N CONCRETE CURB RAMP | 8.000 EA | 1,100.00000 | 8,800.00 |

Dept of Transportation

Revised:

Contract ID: C203788

Project(s): HSIP-0074(156)

Letting Date: 04-18-17 Call Order: 003

Bidder: 3618 - Sealand Contractors Corp.

| Line No. | Item Description | Approx. Quantity and Units | Unit Price Dollars Cts | Bid Amount Dollars Ct |
|----------|-----------------------------------------------------------------------|----------------------------|--------------------------|-------------------------|
| 0058 | 2627000000-E 4" CONCRETE ISLAND COVER | 1,910.000 SY | 57.000000 | 108,870.00 |
| 0059 | 2647000000-E 5" MONOLITHIC CONCRETE ISLANDS(SURFACE MOUNTED) | 420.000 SY | 60.000000 | 25,200.00 |
| 0060 | 2655000000-E 5" MONOLITHIC CONCRETE ISLANDS(KEYED IN) | 3,160.000 SY | 65.000000 | 205,400.00 |
| 0061 | 2657000000-E **" MONOLITHIC CONCRETE MEDIAN(*****) (7", KEYED IN) | 3.000 SY | 150.000000 | 450.00 |
| 0062 | 2759000000-N GENERIC PAVING ITEM EMERGENCY VEHICLE ACCESS | 4.000 EA | 9,100.000000 | 36,400.00 |
| 0063 | 2815000000-N ADJUSTMENT OF DROP INLETS | 2.000 EA | 750.000000 | 1,500.00 |
| 0064 | 2905000000-N CONVERT EXISTING DROP INLET TO JUNCTION BOX | 1.000 EA | 1,600.000000 | 1,600.00 |
| 0065 | 2938000000-N CONVERT EXISTING DROP INLET TO JUNCTION BOX WITH MANHOLE | 4.000 EA | 1,750.000000 | 7,000.00 |
| 0066 | 3030000000-E STEEL BM GUARDRAIL | 150.000 LF | 21.000000 | 3,150.00 |
| 0067 | 3045000000-E STEEL BM GUARDRAIL, SHOP CURVED | 50.000 LF | 23.000000 | 1,150.00 |
| 0068 | 3210000000-N GUARDRAIL ANCHOR UNITS, TYPE CAT-1 | 2.000 EA | 790.000000 | 1,580.00 |

Dept of Transportation

Revised:

Contract ID: C203788

Project(s): HSIP-0074(156)

Letting Date: 04-18-17 Call Order: 003

Bidder: 3618 - Sealand Contractors Corp.

| Line No. | Item Description | Approx. Quantity and Units | Unit Price Dollars Cts | Bid Amount Dollars Ct |
|----------|-----------------------------------------------------------------------------|----------------------------|--------------------------|-------------------------|
| 0069 | 3435000000-N GENERIC GUARDRAIL ITEM EXTRA LENGTH GUARDRAIL POSTS (8' STEEL) | 5.000 EA | 95.00000 | 475.00 |
| 0070 | 3628000000-E RIP RAP, CLASS I | 30.000 TON | 70.00000 | 2,100.00 |
| 0071 | 3635000000-E RIP RAP, CLASS II | 60.000 TON | 75.00000 | 4,500.00 |
| 0072 | 3649000000-E RIP RAP, CLASS B | 25.000 TON | 70.00000 | 1,750.00 |
| 0073 | 3656000000-E GEOTEXTILE FOR DRAINAGE | 215.000 SY | 2.00000 | 430.00 |
| 0074 | 4072000000-E SUPPORTS, 3-LB STEEL U-CHANNEL | 3,221.000 LF | 5.45000 | 17,554.45 |
| 0075 | 4102000000-N SIGN ERECTION, TYPE E | 158.000 EA | 76.00000 | 12,008.00 |
| 0076 | 4108000000-N SIGN ERECTION, TYPE F | 23.000 EA | 110.00000 | 2,530.00 |
| 0077 | 4109000000-N SIGN ERECTION, TYPE *** (OVER-HEAD) (B) | 9.000 EA | 80.00000 | 720.00 |
| 0078 | 4116100000-N SIGN ERECTION, RELOCATE, TYPE ***** (GROUND MOUNTED) (D) | 1.000 EA | 250.00000 | 250.00 |
| 0079 | 4155000000-N DISPOSAL OF SIGN SYSTEM, U-CHANNEL | 44.000 EA | 6.00000 | 264.00 |

Dept of Transportation

Revised:

Contract ID: C203788

Project(s): HSIP-0074(156)

Letting Date: 04-18-17 Call Order: 003

Bidder: 3618 - Sealand Contractors Corp.

| Line No. | Item Description | Approx. Quantity and Units | Unit Price Dollars Cts | Bid Amount Dollars Ct |
|----------|------------------------------------------------------------------|----------------------------|--------------------------|-------------------------|
| 0080 | 4192000000-N DISPOSAL OF SUPPORT, U-CHANNEL | 1.000 EA | 6.00000 | 6.00 |
| 0081 | 4400000000-E WORK ZONE SIGNS (STATIONARY) | 444.000 SF | 6.30000 | 2,797.20 |
| 0082 | 4410000000-E WORK ZONE SIGNS (BARRICADE MOUNTED) | 70.000 SF | 7.35000 | 514.50 |
| 0083 | 4420000000-N PORTABLE CHANGEABLE MESSAGE SIGN | 7.000 EA | 7,900.00000 | 55,300.00 |
| 0084 | 4430000000-N DRUMS | 1,170.000 EA | 25.00000 | 29,250.00 |
| 0085 | 4445000000-E BARRICADES (TYPE III) | 92.000 LF | 25.00000 | 2,300.00 |
| 0086 | 4465000000-N TEMPORARY CRASH CUSHIONS | 2.000 EA | 4,800.00000 | 9,600.00 |
| 0087 | 4490000000-E PORTABLE CONCRETE BARRIER (ANCHORED) | 670.000 LF | 26.00000 | 17,420.00 |
| 0088 | 4510000000-N LAW ENFORCEMENT | 96.000 HR | 45.00000 | 4,320.00 |
| 0089 | 4650000000-N TEMPORARY RAISED PAVEMENT MARKERS | 345.000 EA | 11.25000 | 3,881.25 |
| 0090 | 4685000000-E THERMOPLASTIC PAVEMENT MARKING LINES (4", 90 MILS) | 48,785.000 LF | 0.61000 | 29,758.85 |
| 0091 | 4686000000-E THERMOPLASTIC PAVEMENT MARKING LINES (4", 120 MILS) | 18,260.000 LF | 0.67000 | 12,234.20 |

Dept of Transportation

Revised:

Contract ID: C203788

Project(s): HSIP-0074(156)

Letting Date: 04-18-17 Call Order: 003

Bidder: 3618 - Sealand Contractors Corp.

| Line No. | Item Description | Approx. Quantity and Units | Unit Price Dollars Cts | Bid Amount Dollars Ct |
|----------|-----------------------------------------------------------------------------------|----------------------------|--------------------------|-------------------------|
| 0092 | 4695000000-E THERMOPLAST IC PAVEMENT MARKING LINES (8", 90 MILS) | 9,701.000 LF | 1.05000 | 10,186.05 |
| 0093 | 4697000000-E THERMOPLAST IC PAVEMENT MARKING LINES (8", 120 MILS) | 4,223.000 LF | 1.95000 | 8,234.85 |
| 0094 | 4700000000-E THERMOPLAST IC PAVEMENT MARKING LINES (12", 90 MILS) | 1,007.000 LF | 3.70000 | 3,725.90 |
| 0095 | 4710000000-E THERMOPLAST IC PAVEMENT MARKING LINES (24", 120 MILS) | 2,892.000 LF | 7.90000 | 22,846.80 |
| 0096 | 4721000000-E THERMOPLAST IC PAVEMENT MARKING CHARACTER (120 MILS) | 110.000 EA | 152.00000 | 16,720.00 |
| 0097 | 4725000000-E THERMOPLAST IC PAVEMENT MARKING SYMBOL (90 MILS) | 307.000 EA | 162.00000 | 49,734.00 |
| 0098 | 4770000000-E COLD APPLIED PLASTIC PAVEMENT MARKING LINES, TYPE ** (4") (II) | 550.000 LF | 9.50000 | 5,225.00 |
| 0099 | 4805000000-N COLD APPLIED PLASTIC PAVEMENT MARKING SYMBOL, TYPE ** (II) | 2.000 EA | 1,100.00000 | 2,200.00 |
| 0100 | 4810000000-E PAINT PAVEMENT MARKING LINES (4") | 26,347.000 LF | 0.19000 | 5,005.93 |
| 0101 | 4820000000-E PAINT PAVEMENT MARKING LINES (8") | 5,188.000 LF | 0.42000 | 2,178.96 |
| 0102 | 4835000000-E PAINT PAVEMENT MARKING LINES (24") | 643.000 LF | 4.20000 | 2,700.60 |

Dept of Transportation

Revised:

Contract ID: C203788

Project(s): HSIP-0074(156)

Letting Date: 04-18-17 Call Order: 003

Bidder: 3618 - Sealand Contractors Corp.

| Line No. | Item Description | Approx. Quantity and Units | Unit Price Dollars Cts | Bid Amount Dollars Ct |
|----------|------------------------------------------------------------------------|----------------------------|--------------------------|-------------------------|
| 0103 | 4840000000-N PAINT PAVEMENT MARKING CHARAC-TER | 24.000 EA | 42.00000 | 1,008.00 |
| 0104 | 4845000000-N PAINT PAVEMENT MARKING SYMBOL | 91.000 EA | 58.00000 | 5,278.00 |
| 0105 | 4895000000-N GENERIC PAVEMENT MARKING ITEM IN LANE ROUTE SHIELDS | 6.000 EA | 1,865.00000 | 11,190.00 |
| 0106 | 4900000000-N PERMANENT RAISED PAVEMENT MARKERS | 1,530.000 EA | 10.25000 | 15,682.50 |
| 0107 | 5255000000-N PORTABLE LIGHTING | LUMP | LUMP | 150,000.00 |
| 0108 | 5325200000-E 2" WATER LINE | 417.000 LF | 38.00000 | 15,846.00 |
| 0109 | 5325600000-E 6" WATER LINE | 163.000 LF | 135.00000 | 22,005.00 |
| 0110 | 5326600000-E 16" WATER LINE | 429.000 LF | 225.00000 | 96,525.00 |
| 0111 | 5329000000-E DUCTILE IRON WATER PIPE FITTINGS | 4,300.000 LB | 8.00000 | 34,400.00 |
| 0112 | 5536000000-E 2" VALVE | 1.000 EA | 895.00000 | 895.00 |
| 0113 | 5648000000-N RELOCATE WATER METER | 11.000 EA | 1,300.00000 | 14,300.00 |
| 0114 | 5649000000-N RECONNECT WATER METER | 3.000 EA | 1,500.00000 | 4,500.00 |

Dept of Transportation

Revised:

Contract ID: C203788

Project(s): HSIP-0074(156)

Letting Date: 04-18-17 Call Order: 003

Bidder: 3618 - Sealand Contractors Corp.

| Line No. | Item Description | Approx. Quantity and Units | Unit Price Dollars Cts | Bid Amount Dollars Ct |
|----------|-------------------------------------------------|----------------------------|--------------------------|-------------------------|
| 0115 | 5672000000-N RELOCATE FIRE HYDRANT | 1.000 EA | 4,000.00000 | 4,000.00 |
| 0116 | 5685200000-E 16" LINE STOP WITH BYPASS | 4.000 EA | 22,000.00000 | 88,000.00 |
| 0117 | 5800000000-E ABANDON 6" UTILITY PIPE | 160.000 LF | 15.00000 | 2,400.00 |
| 0118 | 5810000000-E ABANDON 16" UTILITY PIPE | 425.000 LF | 20.00000 | 8,500.00 |
| 0119 | 6000000000-E TEMPORARY SILT FENCE | 6,315.000 LF | 1.85000 | 11,682.75 |
| 0120 | 6006000000-E STONE FOR EROSION CONTROL, CLASS A | 125.000 TON | 55.00000 | 6,875.00 |
| 0121 | 6009000000-E STONE FOR EROSION CONTROL, CLASS B | 225.000 TON | 55.00000 | 12,375.00 |
| 0122 | 6012000000-E SEDIMENT CONTROL STONE | 220.000 TON | 41.00000 | 9,020.00 |
| 0123 | 6015000000-E TEMPORARY MULCHING | 7.500 ACR | 525.00000 | 3,937.50 |
| 0124 | 6018000000-E SEED FOR TEMPORARY SEEDING | 400.000 LB | 2.65000 | 1,060.00 |
| 0125 | 6021000000-E FERTILIZER FOR TEMPORARY SEED-ING | 2.000 TON | 950.00000 | 1,900.00 |
| 0126 | 6024000000-E TEMPORARY SLOPE DRAINS | 200.000 LF | 13.25000 | 2,650.00 |

Contract ID: C203788

Project(s): HSIP-0074(156)

Letting Date: 04-18-17 Call Order: 003

Bidder: 3618 - Sealand Contractors Corp.

| Line No. | Item Description | Approx. Quantity and Units | Unit Price Dollars Cts | Bid Amount Dollars Ct |
|----------|-----------------------------------------------|----------------------------|--------------------------|-------------------------|
| 0127 | 6029000000-E SAFETY FENCE | 200.000 LF | 2.00000 | 400.00 |
| 0128 | 6030000000-E SILT EXCAVATION | 400.000 CY | 18.00000 | 7,200.00 |
| 0129 | 6036000000-E MATTING FOR EROSION CONTROL | 29,900.000 SY | 1.58000 | 47,242.00 |
| 0130 | 6037000000-E COIR FIBER MAT | 100.000 SY | 4.00000 | 400.00 |
| 0131 | 6038000000-E PERMANENT SOIL REINFORCEMENT MAT | 350.000 SY | 3.50000 | 1,225.00 |
| 0132 | 6042000000-E 1/4" HARDWARE CLOTH | 300.000 LF | 4.50000 | 1,350.00 |
| 0133 | 6071010000-E WATTLE | 4,960.000 LF | 4.20000 | 20,832.00 |
| 0134 | 6071020000-E POLYACRYLAMIDE (PAM) | 50.000 LB | 8.50000 | 425.00 |
| 0135 | 6071030000-E COIR FIBER BAFFLE | 100.000 LF | 4.25000 | 425.00 |
| 0136 | 6084000000-E SEEDING & MULCHING | 9.000 ACR | 1,725.00000 | 15,525.00 |
| 0137 | 6087000000-E MOWING | 6.000 ACR | 130.00000 | 780.00 |
| 0138 | 6090000000-E SEED FOR REPAIR SEEDING | 100.000 LB | 2.65000 | 265.00 |

Dept of Transportation

Revised:

Contract ID: C203788

Project(s): HSIP-0074(156)

Letting Date: 04-18-17 Call Order: 003

Bidder: 3618 - Sealand Contractors Corp.

| Line No. | Item Description | Approx. Quantity and Units | Unit Price Dollars Cts | Bid Amount Dollars Ct |
|----------|----------------------------------------------------------------------|----------------------------|--------------------------|-------------------------|
| 0139 | 6093000000-E FERTILIZER FOR REPAIR SEEDING | 0.250 TON | 950.00000 | 237.50 |
| 0140 | 6096000000-E SEED FOR SUPPLEMENTAL SEEDING | 175.000 LB | 2.65000 | 463.75 |
| 0141 | 6108000000-E FERTILIZER TOPDRESSING | 4.750 TON | 950.00000 | 4,512.50 |
| 0142 | 6114500000-N SPECIALIZED HAND MOWING | 10.000 MHR | 95.00000 | 950.00 |
| 0143 | 6117000000-N RESPONSE FOR EROSION CONTROL | 75.000 EA | 310.00000 | 23,250.00 |
| 0144 | 6132000000-N GENERIC EROSION CONTROL ITEM CONCRETE WASHOUT STRUCTURE | 2.000 EA | 1,200.00000 | 2,400.00 |
| 0145 | 7048500000-E PEDESTRIAN SIGNAL HEAD (16", 1SECTION W/COUNTDOWN) | 18.000 EA | 680.00000 | 12,240.00 |
| 0146 | 7060000000-E SIGNAL CABLE | 12,180.000 LF | 1.05000 | 12,789.00 |
| 0147 | 7120000000-E VEHICLE SIGNAL HEAD (12", 3 SECTION) | 64.000 EA | 665.00000 | 42,560.00 |
| 0148 | 7132000000-E VEHICLE SIGNAL HEAD (12", 4 SECTION) | 12.000 EA | 830.00000 | 9,960.00 |
| 0149 | 7252000000-E MESSENGER CABLE (1/4") | 170.000 LF | 4.25000 | 722.50 |

Dept of Transportation

Revised:

Contract ID: C203788

Project(s): HSIP-0074(156)

Letting Date: 04-18-17 Call Order: 003

Bidder: 3618 - Sealand Contractors Corp.

| Line No. | Item Description | Approx. Quantity and Units | Unit Price Dollars Cts | Bid Amount Dollars Ct |
|----------|-----------------------------------------------------------|----------------------------|--------------------------|-------------------------|
| 0150 | 7264000000-E MESSENGER CABLE (3/8") | 5,480.000 | 5.80000 | 31,784.00 |
| | | LF | | |
| 0151 | 7288000000-E PAVED TRENCHING (*****) (1, 2") | 50.000 | 40.00000 | 2,000.00 |
| | | LF | | |
| 0152 | 7288000000-E PAVED TRENCHING (*****) (2, 2") | 70.000 | 43.00000 | 3,010.00 |
| | | LF | | |
| 0153 | 7300000000-E UNPAVED TRENCHING (*****) (1, 2") | 9,050.000 | 6.85000 | 61,992.50 |
| | | LF | | |
| 0154 | 7300000000-E UNPAVED TRENCHING (*****) (2, 2") | 200.000 | 9.00000 | 1,800.00 |
| | | LF | | |
| 0155 | 7300000000-E UNPAVED TRENCHING (*****) (3, 2") | 570.000 | 10.65000 | 6,070.50 |
| | | LF | | |
| 0156 | 7300000000-E UNPAVED TRENCHING (*****) (5, 2") | 140.000 | 15.75000 | 2,205.00 |
| | | LF | | |
| 0157 | 7300000000-E UNPAVED TRENCHING (*****) (6, 2") | 10.000 | 20.00000 | 200.00 |
| | | LF | | |
| 0158 | 7300000000-E UNPAVED TRENCHING (*****) (7, 2") | 40.000 | 22.00000 | 880.00 |
| | | LF | | |
| 0159 | 7300100000-E UNPAVED TRENCHING FOR TEMP- ORARY LEAD-IN | 90.000 | 6.00000 | 540.00 |
| | | LF | | |
| 0160 | 7301000000-E DIRECTIONAL DRILL (*****) (2, 2") | 1,360.000 | 17.50000 | 23,800.00 |
| | | LF | | |
| 0161 | 7324000000-N JUNCTION BOX (STANDARD SIZE) | 123.000 | 345.00000 | 42,435.00 |
| | | EA | | |

Dept of Transportation

Revised:

Contract ID: C203788

Project(s): HSIP-0074(156)

Letting Date: 04-18-17 Call Order: 003

Bidder: 3618 - Sealand Contractors Corp.

| Line No. | Item Description | Approx. Quantity and Units | Unit Price Dollars Cts | Bid Amount Dollars Ct |
|----------|-----------------------------------------------------|----------------------------|--------------------------|-------------------------|
| 0162 | 7348000000-N JUNCTION BOX (OVER-SIZED, HEA-VY DUTY) | 16.000 EA | 660.00000 | 10,560.00 |
| 0163 | 7360000000-N WOOD POLE | 42.000 EA | 890.00000 | 37,380.00 |
| 0164 | 7372000000-N GUY ASSEMBLY | 64.000 EA | 500.00000 | 32,000.00 |
| 0165 | 7408000000-E 1" RISER WITH WEATHERHEAD | 7.000 EA | 260.00000 | 1,820.00 |
| 0166 | 7420000000-E 2" RISER WITH WEATHERHEAD | 56.000 EA | 395.00000 | 22,120.00 |
| 0167 | 7432000000-E 2" RISER WITH HEAT SHRINK TUBING | 16.000 EA | 410.00000 | 6,560.00 |
| 0168 | 7444000000-E INDUCTIVE LOOP SAWCUT | 13,680.000 LF | 6.45000 | 88,236.00 |
| 0169 | 7456000000-E LEAD-IN CABLE (*****)(14-2) | 41,540.000 LF | 1.37000 | 56,909.80 |
| 0170 | 7636000000-N SIGN FOR SIGNALS | 20.000 EA | 290.00000 | 5,800.00 |
| 0171 | 7642100000-N TYPE I POST WITH FOUNDATION | 4.000 EA | 1,160.00000 | 4,640.00 |
| 0172 | 7642200000-N TYPE II PEDESTAL WITH FOUNDATION | 14.000 EA | 1,575.00000 | 22,050.00 |
| 0173 | 7684000000-N SIGNAL CABINET FOUNDATION | 16.000 EA | 835.00000 | 13,360.00 |

Dept of Transportation

Revised:

Contract ID: C203788

Project(s): HSIP-0074(156)

Letting Date: 04-18-17 Call Order: 003

Bidder: 3618 - Sealand Contractors Corp.

| Line No. | Item Description | Approx. Quantity and Units | Unit Price Dollars Cts | Bid Amount Dollars Ct |
|--------------------|--------------------------------------------------------------------------------------------|----------------------------|--------------------------|-------------------------|
| 0174 | 7686000000-N CONDUIT ENTRANCE INTO EXISTING FOUNDATION | 1.000 EA | 650.00000 | 650.00 |
| 0175 | 7756000000-N CONTROLLER WITH CABINET (TYPE 2070L, BASE MOUNTED) | 16.000 EA | 14,200.00000 | 227,200.00 |
| 0176 | 7780000000-N DETECTOR CARD (TYPE 2070L) | 66.000 EA | 105.00000 | 6,930.00 |
| 0177 | 7901000000-N CABINET BASE EXTENDER | 16.000 EA | 415.00000 | 6,640.00 |
| 0178 | 7980000000-N GENERIC SIGNAL ITEM 900 MHZ SERIAL/ETHERNET RADIO, USING EXISTING ANTENNA (S) | 1.000 EA | 2,650.00000 | 2,650.00 |
| 0179 | 7980000000-N GENERIC SIGNAL ITEM 900 MHZ SERIAL/ETHERNET SPREAD SPECTRUM RADIO | 16.000 EA | 4,100.00000 | 65,600.00 |
| 0180 | 7980000000-N GENERIC SIGNAL ITEM ETHERNET EDGE SWITCH | 19.000 EA | 1,725.00000 | 32,775.00 |
| 0181 | 7980000000-N GENERIC SIGNAL ITEM REPLACE CONFLICT MONITOR | 1.000 EA | 1,315.00000 | 1,315.00 |
| 0182 | 7980000000-N GENERIC SIGNAL ITEM REPLACE CONTROLLER | 1.000 EA | 2,500.00000 | 2,500.00 |
| 0183 | 8802040000-E CIP GRAVITY RETAINING WALLS | 538.000 SF | 175.00000 | 94,150.00 |
| Section 0001 Total | | | | 9,544,080.09 |

NON-COLLUSION AND DEBARMENT CERTIFICATION

The bidder certifies that neither he, nor any official, agent or employee of the bidder has entered into any agreement, participated in any collusion, or otherwise taken any action which is in restraint of free competitive bidding in connection with this bid, and that the bidder intends to do the work with its own bonafide employees or subcontractors and is not bidding for the benefit of another contractor. In addition, submitting this electronic bid constitutes the bidder's certification of Status under penalty of perjury under the laws of the United States and in accordance with the Debarment Certification on file with the Department.

By submitting this bid, the bidder certifies to the best of his knowledge and belief that he and his principals:

- a. Are not presently debarred, suspended, proposed for debarment, declared ineligible, or voluntarily excluded from covered transactions by any Federal department or agency;
- b. Have not within a three-year period preceding this proposal been convicted of or had a civil judgment rendered against them for commission of fraud or a criminal offense in connection with obtaining, attempting to obtain, or performing a public (Federal, State or local) transaction or contract under a public transaction; violation of Federal or State antitrust statutes or commission of embezzlement, theft, forgery, bribery, falsification or destruction of records; making false statements; or receiving stolen property;
- c. Are not presently indicted for or otherwise criminally or civilly charged by a governmental entity (Federal, State or local) with commission of any of the offenses enumerated in paragraph b. of this certification; and
- d. Have not within a three-year period preceding this proposal had one or more public transactions (Federal, State or local) terminated for cause or default.

Where the prospective bidder is unable to certify to any of the statements in this certification, the bidder shall submit an explanation in the blanks provided herein. The explanation will not necessarily result in denial of participation in a contract.

Explanation:
NOT ANSWERED
NOT ANSWERED
NOT ANSWERED
NOT ANSWERED

If the prequalified bidder's status changes, he shall immediately submit a new fully executed non-collusion affidavit and debarment certification with an explanation of the change to the Contract Office prior to submitting the bid.

Failure to furnish a certification or an explanation will be grounds for rejection of a bid

AWARD LIMITS ON MULTIPLE PROJECTS

By answering YES to this statement, the bidder acknowledges that they are using the award limits on multiple projects. No

A bidder who desires to bid on more than one project on which bids are to be opened on the same date, and who also desires to avoid receiving an award of more projects than he is equipped to handle, may bid on any number of projects but may limit the total amount of work awarded to him on selected projects by completing the AWARD LIMITS ON MULTIPLE PROJECTS.

The Award Limits on Multiple Projects must be filled in on each project bid for which the Bidder desires protection.

It is the desire of the Bidder to be awarded contracts, the value of which will not exceed a total of NOT ANSWERED for those projects indicated herein, for which bids will be opened on (MM/DD/YY)

The Award Limits shall apply to the following projects:

| Contract Number | County |
|-----------------|--------|
| NOT ANSWERED | |
| NOT ANSWERED | |
| NOT ANSWERED | |
| NOT ANSWERED | |
| NOT ANSWERED | |
| NOT ANSWERED | |

It is agreed that if I am (we are) the low Bidder(s) on indicated projects, the total value of which is more than the above stipulated award limits, the Board of Transportation will award me (us) projects from among those indicated that have a total value not to exceed the award limit and will result in the lowest total bids to the Department of Transportation.

DBE COMMITMENT ITEMS

PROPOSAL: C203788
 LETTING: L170418 CALL: 003
 VENDOR: 3618 Sealand Contractors Corp.

| LINE NO. | ITEM NO. | ITEM DESC. | UNIT TYPE | SUBCONTRACTOR QUANTITY | SUBCONTRACTOR UNIT PRICE | EXTENDED AMOUNT |
|-------------------------------------------|--------------|--------------------------|-----------|------------------------|--------------------------|-----------------|
| ----- | | | | | | |
| DBE SUBCONTRACTOR: 11238 BKP TRUCKING LLC | | | | | | |
| Will Use Quote: Yes | | | | | | |
| 0003 | 0043000000-N | GRADING | LS | 1.000 | 355663.00000 | 355663.00 |
| | | 4,619 Hrs. x \$77.00/Hr. | | | | |
| 0005 | 0057000000-E | UNDERCUT EXC | CY | 663.000 | 77.00000 | 51051.00 |
| | | 663 Hrs. x \$77.00/Hr. | | | | |
| 0006 | 0134000000-E | DRAINAGE DIT | CY | 10.500 | 77.00000 | 808.50 |
| | | 10.50 Hrs. x \$77.00/Hr. | | | | |
| 0011 | 0343000000-E | 15" SIDE DRA | LF | 47.000 | 77.00000 | 3619.00 |
| | | 47 Hrs. x \$77.00/Hr. | | | | |
| 0012 | 0344000000-E | 18" SIDE DRA | LF | 4.500 | 77.00000 | 346.50 |
| | | 4.5 Hrs. x \$77.00/Hr. | | | | |
| 0013 | 0366000000-E | 15" RC PIPE | LF | 55.000 | 77.00000 | 4235.00 |
| | | 55 Hrs. x \$77.00/Hr. | | | | |
| 0014 | 0384000000-E | 30" RC PIPE | LF | 8.000 | 77.00000 | 616.00 |
| | | 8 Hrs. x \$77.00/Hr. | | | | |
| 0015 | 0390000000-E | 36" RC PIPE | LF | 108.000 | 77.00000 | 8316.00 |
| | | 108 Hrs. x \$77.00/Hr. | | | | |
| 0016 | 0448200000-E | 15" RCP CULV | LF | 692.000 | 77.00000 | 53284.00 |
| | | 692 Hrs. x \$77.00/Hr. | | | | |
| 0017 | 0448300000-E | 18" RCP CULV | LF | 82.000 | 77.00000 | 6314.00 |
| | | 82 Hrs. x \$77.00/Hr. | | | | |
| 0018 | 0448500000-E | 30" RCP CULV | LF | 2.500 | 77.00000 | 192.50 |
| | | 2.5 Hrs. x \$77.00/Hr. | | | | |
| 0019 | 0576000000-E | **" CS PIPE | LF | 16.500 | 77.00000 | 1270.50 |
| | | 16.5 Hrs. x \$77.00/Hr. | | | | |
| 0027 | 0995000000-E | PIPE REMOVAL | LF | 250.000 | 77.00000 | 19250.00 |
| | | 250 Hrs. x \$77.00/Hr. | | | | |
| 0028 | 1099500000-E | SHALLOW UNDE | CY | 38.000 | 77.00000 | 2926.00 |
| | | 38 Hrs. x \$77.00/Hr. | | | | |
| 0030 | 1220000000-E | INCIDENTAL S | TON | 35.000 | 77.00000 | 2695.00 |
| | | 35 Hrs. x \$77.00/Hr. | | | | |
| 0031 | 1297000000-E | MILL ASP PVM | SY | 156.000 | 77.00000 | 12012.00 |
| | | 156 Hrs. x \$77.00/Hr. | | | | |
| 0032 | 1330000000-E | INCIDENTAL M | SY | 125.000 | 77.00000 | 9625.00 |
| | | 125 Hrs. x \$77.00/Hr. | | | | |
| 0033 | 1491000000-E | ASP CONC BAS | TON | 2213.000 | 77.00000 | 170401.00 |
| | | 2,213 Hrs. x \$77.00/Hr. | | | | |
| 0034 | 1503000000-E | ASP CONC INT | TON | 790.000 | 77.00000 | 60830.00 |
| | | 790 Hrs. x \$77.00/Hr. | | | | |
| 0035 | 1523000000-E | ASP CONC SUR | TON | 1610.000 | 77.00000 | 123970.00 |
| | | 1,610 Hrs. x \$77.00/Hr. | | | | |
| 0036 | 1525000000-E | ASP CONC SUR | TON | 16.000 | 77.00000 | 1232.00 |
| | | 16 Hrs. x \$77.00/Hr. | | | | |
| 0038 | 1693000000-E | ASPH PLT MIX | TON | 218.000 | 77.00000 | 16786.00 |
| | | 218 Hrs. x \$77.00/Hr. | | | | |
| ----- | | | | | | |

PROPOSAL: C203788
 LETTING: L170418 CALL: 003
 VENDOR: 3618 Sealand Contractors Corp.

| LINE NO. | ITEM NO. | ITEM DESC. | UNIT TYPE | SUBCONTRACTOR QUANTITY | SUBCONTRACTOR UNIT PRICE | EXTENDED AMOUNT |
|----------|--------------|------------------------|-----------|------------------------|--------------------------|-----------------|
| 0039 | 1891000000-E | GENERIC PAVI | SY | 260.000 | 77.00000 | 20020.00 |
| | | 260 Hrs. x \$77.00/Hr. | | | | |
| 0044 | 2286000000-N | MASNRY DRAIN | EA | 1.000 | 17325.00000 | 17325.00 |
| | | 225 Hrs. x \$77.00/Hr. | | | | |
| 0045 | 2297000000-E | MASNRY DRAIN | CY | 1.000 | 770.00000 | 770.00 |
| | | 10 Hrs. x \$77.00/Hr. | | | | |
| 0046 | 2308000000-E | MASNRY DRAIN | LF | 9.000 | 77.00000 | 693.00 |
| | | 9 Hrs. x \$77.00/Hr. | | | | |
| 0063 | 2815000000-N | ADJ DROP INL | EA | 1.000 | 77.00000 | 77.00 |
| | | 1 Hrs. x \$77.00/Hr. | | | | |
| 0064 | 2905000000-N | CONVERT DI T | EA | 1.000 | 77.00000 | 77.00 |
| | | 1 Hrs. x \$77.00/Hr. | | | | |
| 0065 | 2938000000-N | CONVERT DI T | EA | 1.000 | 462.00000 | 462.00 |
| | | 6 Hrs. x \$77.00/Hr. | | | | |
| 0108 | 5325200000-E | 2" WATER LIN | LF | 16.000 | 77.00000 | 1232.00 |
| | | 16 Hrs. x \$77.00/Hr. | | | | |
| 0109 | 5325600000-E | 6" WATER LIN | LF | 21.000 | 77.00000 | 1617.00 |
| | | 21 Hrs. x \$77.00/Hr. | | | | |
| 0110 | 5326600000-E | 16" WATER LI | LF | 62.000 | 77.00000 | 4774.00 |
| | | 62 Hrs. x \$77.00/Hr. | | | | |
| 0116 | 5685200000-E | 16" LINE STO | EA | 1.000 | 847.00000 | 847.00 |
| | | 11 Hrs. x \$77.00/Hr. | | | | |
| 0072 | 3649000000-E | RIP RAP, CLA | TON | 2.000 | 77.00000 | 154.00 |
| | | 2 Hrs. x \$77.00/Hr. | | | | |
| 0122 | 6012000000-E | SEDIMENT CON | TON | 12.000 | 77.00000 | 924.00 |
| | | 12 Hrs. x \$77.00/Hr. | | | | |

DBE COMMITMENT TOTAL FOR SUBCONTRACTOR: 954,415.00
 DBE COMMITMENT TOTAL FOR VENDOR (SubContractor) 954,415

TOTAL DBE COMMITMENT FOR VENDOR: Entered: 10.00% or 954415.00
 Required: 10.00% or 954408.01
 <GOAL MET>

THIS PROPOSAL CONTAINS THE FOLLOWING ERRORS/WARNINGS (IF ANY)

This Bid contains 0 amendment files

Electronic Bid Submission

By submitting this bid electronically, I hereby acknowledge that all requirements included in the hard copy proposal, addendum, amendments, plans, standard specifications, supplemental specifications and special provisions are part of the bid and contract. Further, I acknowledge that I have read, understand, accept, acknowledge and agree to comply with all statements in this electronic bid.

I Hereby certify that I have the authority to submit this bid.

Signature

Agency

Date

| Line # | ItemNumber | Sec # | Description | Quantity Unit | Unit Bid Price | Amount Bid |
|----------------------|--------------|-------|---------------------------------------------------------|----------------|----------------|--------------|
| ROADWAY ITEMS | | | | | | |
| 0001 | 0000100000-N | 800 | MOBILIZATION | Lump Sum LS | 477,000.00 | 477,000.00 |
| 0002 | 0000400000-N | 801 | CONSTRUCTION SURVEYING | Lump Sum LS | 100,000.00 | 100,000.00 |
| 0003 | 0043000000-N | 226 | GRADING | Lump Sum LS | 1,255,000.00 | 1,255,000.00 |
| 0004 | 0050000000-E | 226 | SUPPLEMENTARY CLEARING & GRUB- BING | 1 ACR | 10,000.00 | 10,000.00 |
| 0005 | 0057000000-E | 226 | UNDERCUT EXCAVATION | 2,017 CY | 44.00 | 88,748.00 |
| 0006 | 0134000000-E | 240 | DRAINAGE DITCH EXCAVATION | 120 CY | 15.00 | 1,800.00 |
| 0007 | 0196000000-E | 270 | GEOTEXTILE FOR SOIL STABILIZA- TION | 400 SY | 2.00 | 800.00 |
| 0008 | 0199000000-E | SP | TEMPORARY SHORING | 576 SF | 89.00 | 51,264.00 |
| 0009 | 0318000000-E | 300 | FOUNDATION CONDITIONING MATE- RIAL, MINOR STRUCTURES | 960 TON | 42.00 | 40,320.00 |
| 0010 | 0320000000-E | 300 | FOUNDATION CONDITIONING GEO- TEXTILE | 2,970 SY | 1.00 | 2,970.00 |
| 0011 | 0343000000-E | 310 | 15" SIDE DRAIN PIPE | 442 LF | 49.00 | 21,658.00 |
| 0012 | 0344000000-E | 310 | 18" SIDE DRAIN PIPE | 40 LF | 52.00 | 2,080.00 |
| 0013 | 0366000000-E | 310 | 15" RC PIPE CULVERTS, CLASS III | 540 LF | 47.00 | 25,380.00 |
| 0014 | 0384000000-E | 310 | 30" RC PIPE CULVERTS, CLASS III | 32 LF | 105.00 | 3,360.00 |
| 0015 | 0390000000-E | 310 | 36" RC PIPE CULVERTS, CLASS III | 440 LF | 108.00 | 47,520.00 |
| 0016 | 0448200000-E | 310 | 15" RC PIPE CULVERTS, CLASS IV | 6,004 LF | 54.00 | 324,216.00 |
| 0017 | 0448300000-E | 310 | 18" RC PIPE CULVERTS, CLASS IV | 688 LF | 59.00 | 40,592.00 |
| 0018 | 0448500000-E | 310 | 30" RC PIPE CULVERTS, CLASS IV | 8 LF | 200.00 | 1,600.00 |
| 0019 | 0576000000-E | 310 | *** CS PIPE CULVERTS, ***** THICK (15", 0.064") | 110 LF | 67.00 | 7,370.00 |

| Line # | ItemNumber | Sec # | Description | Quantity Unit | Unit Bid Price | Amount Bid |
|--------|--------------|-------|-----------------------------------------------------------------------------|---------------|----------------|--------------|
| 0020 | 0636000000-E | 310 | *** CS PIPE ELBOWS, ***** THICK (15", 0.064") | 6 EA | 400.00 | 2,400.00 |
| 0021 | 0973100000-E | 330 | *** WELDED STEEL PIPE, ***** THICK, GRADE B IN SOIL (15", 0.250") | 43 LF | 215.00 | 9,245.00 |
| 0022 | 0973100000-E | 330 | *** WELDED STEEL PIPE, ***** THICK, GRADE B IN SOIL (18", 0.250") | 32 LF | 235.00 | 7,520.00 |
| 0023 | 0973100000-E | 330 | *** WELDED STEEL PIPE, ***** THICK, GRADE B IN SOIL (42", 0.625") | 68 LF | 515.00 | 35,020.00 |
| 0024 | 0973300000-E | 330 | *** WELDED STEEL PIPE, ***** THICK, GRADE B NOT IN SOIL (15", 0.250") | 43 LF | 645.00 | 27,735.00 |
| 0025 | 0973300000-E | 330 | *** WELDED STEEL PIPE, ***** THICK, GRADE B NOT IN SOIL (18", 0.250") | 32 LF | 660.00 | 21,120.00 |
| 0026 | 0973300000-E | 330 | *** WELDED STEEL PIPE, ***** THICK, GRADE B NOT IN SOIL (42", 0.625") | 68 LF | 1,305.00 | 88,740.00 |
| 0027 | 0995000000-E | 340 | PIPE REMOVAL | 2,251 LF | 21.00 | 47,271.00 |
| 0028 | 1099500000-E | 505 | SHALLOW UNDERCUT | 200 CY | 25.00 | 5,000.00 |
| 0029 | 1099700000-E | 505 | CLASS IV SUBGRADE STABILIZA- TION | 300 TON | 32.00 | 9,600.00 |
| 0030 | 1220000000-E | 545 | INCIDENTAL STONE BASE | 1,000 TON | 32.00 | 32,000.00 |
| 0031 | 1297000000-E | 607 | MILLING ASPHALT PAVEMENT, ***** DEPTH (1-1/2") | 12,030 SY | 4.25 | 51,127.50 |
| 0032 | 1330000000-E | 607 | INCIDENTAL MILLING | 4,166 SY | 10.00 | 41,660.00 |
| 0033 | 1491000000-E | 610 | ASPHALT CONC BASE COURSE, TYPE B25.0C | 16,300 TON | 69.00 | 1,124,700.00 |
| 0034 | 1503000000-E | 610 | ASPHALT CONC INTERMEDIATE COURSE, TYPE I19.0C | 6,670 TON | 69.00 | 460,230.00 |

| Line # | ItemNumber | Sec # | Description | Quantity Unit | Unit Bid Price | Amount Bid |
|--------|--------------|-------|--------------------------------------------------------|---------------|----------------|--------------|
| 0035 | 1523000000-E | 610 | ASPHALT CONC SURFACE COURSE, TYPE S9.5C | 14,860 TON | 69.00 | 1,025,340.00 |
| 0036 | 1525000000-E | 610 | ASPHALT CONC SURFACE COURSE, TYPE SF9.5A | 60 TON | 125.00 | 7,500.00 |
| 0037 | 1575000000-E | 620 | ASPHALT BINDER FOR PLANT MIX | 1,920 TON | 467.00 | 896,640.00 |
| 0038 | 1693000000-E | 654 | ASPHALT PLANT MIX, PAVEMENT REPAIR | 670 TON | 185.00 | 123,950.00 |
| 0039 | 1891000000-E | SP | GENERIC PAVING ITEM VARIABLE DEPTH MILLING | 25,000 SY | 2.65 | 66,250.00 |
| 0040 | 2209000000-E | 838 | ENDWALLS | 7.204 CY | 1,150.00 | 8,284.60 |
| 0041 | 2253000000-E | 840 | PIPE COLLARS | 2.604 CY | 1,100.00 | 2,864.40 |
| 0042 | 2264000000-E | 840 | PIPE PLUGS | 0.045 CY | 1,250.00 | 56.25 |
| 0043 | 2275000000-E | SP | FLOWABLE FILL | 23 CY | 225.00 | 5,175.00 |
| 0044 | 2286000000-N | 840 | MASONRY DRAINAGE STRUCTURES | 135 EA | 1,700.00 | 229,500.00 |
| 0045 | 2297000000-E | 840 | MASONRY DRAINAGE STRUCTURES | 9.6 CY | 2,670.00 | 25,632.00 |
| 0046 | 2308000000-E | 840 | MASONRY DRAINAGE STRUCTURES | 15.7 LF | 340.00 | 5,338.00 |
| 0047 | 2364000000-N | 840 | FRAME WITH TWO GRATES, STD 840.16 | 73 EA | 425.00 | 31,025.00 |
| 0048 | 2364200000-N | 840 | FRAME WITH TWO GRATES, STD 840.20 | 2 EA | 485.00 | 970.00 |
| 0049 | 2365000000-N | 840 | FRAME WITH TWO GRATES, STD 840.22 | 19 EA | 485.00 | 9,215.00 |
| 0050 | 2374000000-N | 840 | FRAME WITH GRATE & HOOD, STD 840.03, TYPE ** (F) | 18 EA | 510.00 | 9,180.00 |
| 0051 | 2374000000-N | 840 | FRAME WITH GRATE & HOOD, STD 840.03, TYPE ** (G) | 16 EA | 510.00 | 8,160.00 |
| 0052 | 2396000000-N | 840 | FRAME WITH COVER, STD 840.54 | 12 EA | 300.00 | 3,600.00 |

| Line # | ItemNumber | Sec # | Description | Quantity Unit | Unit Bid Price | Amount Bid |
|--------|--------------|-------|----------------------------------------------------------------|---------------|----------------|------------|
| 0053 | 2451000000-N | 852 | CONCRETE TRANSITIONAL SECTION FOR DROP INLET | 71 EA | 725.00 | 51,475.00 |
| 0054 | 2542000000-E | 846 | 1'-6" CONCRETE CURB & GUTTER | 280 LF | 22.75 | 6,370.00 |
| 0055 | 2549000000-E | 846 | 2'-6" CONCRETE CURB & GUTTER | 6,780 LF | 23.00 | 155,940.00 |
| 0056 | 2591000000-E | 848 | 4" CONCRETE SIDEWALK | 450 SY | 40.00 | 18,000.00 |
| 0057 | 2605000000-N | 848 | CONCRETE CURB RAMP | 8 EA | 1,100.00 | 8,800.00 |
| 0058 | 2627000000-E | 852 | 4" CONCRETE ISLAND COVER | 1,910 SY | 57.00 | 108,870.00 |
| 0059 | 2647000000-E | 852 | 5" MONOLITHIC CONCRETE ISLANDS (SURFACE MOUNTED) | 420 SY | 60.00 | 25,200.00 |
| 0060 | 2655000000-E | 852 | 5" MONOLITHIC CONCRETE ISLANDS (KEYED IN) | 3,160 SY | 65.00 | 205,400.00 |
| 0061 | 2657000000-E | 852 | *** MONOLITHIC CONCRETE MEDIAN (*****) (7", KEYED IN) | 3 SY | 150.00 | 450.00 |
| 0062 | 2759000000-N | SP | GENERIC PAVING ITEM EMERGENCY VEHICLE ACCESS | 4 EA | 9,100.00 | 36,400.00 |
| 0063 | 2815000000-N | 858 | ADJUSTMENT OF DROP INLETS | 2 EA | 750.00 | 1,500.00 |
| 0064 | 2905000000-N | 859 | CONVERT EXISTING DROP INLET TO JUNCTION BOX | 1 EA | 1,600.00 | 1,600.00 |
| 0065 | 2938000000-N | 859 | CONVERT EXISTING DROP INLET TO JUNCTION BOX WITH MANHOLE | 4 EA | 1,750.00 | 7,000.00 |
| 0066 | 3030000000-E | 862 | STEEL BM GUARDRAIL | 150 LF | 21.00 | 3,150.00 |
| 0067 | 3045000000-E | 862 | STEEL BM GUARDRAIL, SHOP CURVED | 50 LF | 23.00 | 1,150.00 |
| 0068 | 3210000000-N | 862 | GUARDRAIL ANCHOR UNITS, TYPE CAT-1 | 2 EA | 790.00 | 1,580.00 |
| 0069 | 3435000000-N | SP | GENERIC GUARDRAIL ITEM EXTRA LENGTH GUARDRAIL POSTS (8' STEEL) | 5 EA | 95.00 | 475.00 |
| 0070 | 3628000000-E | 876 | RIP RAP, CLASS I | 30 TON | 70.00 | 2,100.00 |

| Line # | ItemNumber | Sec # | Description | Quantity Unit | Unit Bid Price | Amount Bid |
|--------|--------------|-------|------------------------------------------------------------|---------------|----------------|------------|
| 0071 | 3635000000-E | 876 | RIP RAP, CLASS II | 60 TON | 75.00 | 4,500.00 |
| 0072 | 3649000000-E | 876 | RIP RAP, CLASS B | 25 TON | 70.00 | 1,750.00 |
| 0073 | 3656000000-E | 876 | GEOTEXTILE FOR DRAINAGE | 215 SY | 2.00 | 430.00 |
| 0074 | 4072000000-E | 903 | SUPPORTS, 3-LB STEEL U-CHANNEL | 3,221 LF | 5.45 | 17,554.45 |
| 0075 | 4102000000-N | 904 | SIGN ERECTION, TYPE E | 158 EA | 76.00 | 12,008.00 |
| 0076 | 4108000000-N | 904 | SIGN ERECTION, TYPE F | 23 EA | 110.00 | 2,530.00 |
| 0077 | 4109000000-N | 904 | SIGN ERECTION, TYPE *** (OVER-HEAD) (B) | 9 EA | 80.00 | 720.00 |
| 0078 | 4116100000-N | 904 | SIGN ERECTION, RELOCATE, TYPE **** (GROUND MOUNTED) (D) | 1 EA | 250.00 | 250.00 |
| 0079 | 4155000000-N | 907 | DISPOSAL OF SIGN SYSTEM, U-CHANNEL | 44 EA | 6.00 | 264.00 |
| 0080 | 4192000000-N | 907 | DISPOSAL OF SUPPORT, U-CHANNEL | 1 EA | 6.00 | 6.00 |
| 0081 | 4400000000-E | 1110 | WORK ZONE SIGNS (STATIONARY) | 444 SF | 6.30 | 2,797.20 |
| 0082 | 4410000000-E | 1110 | WORK ZONE SIGNS (BARRICADE MOUNTED) | 70 SF | 7.35 | 514.50 |
| 0083 | 4420000000-N | 1120 | PORTABLE CHANGEABLE MESSAGE SIGN | 7 EA | 7,900.00 | 55,300.00 |
| 0084 | 4430000000-N | 1130 | DRUMS | 1,170 EA | 25.00 | 29,250.00 |
| 0085 | 4445000000-E | 1145 | BARRICADES (TYPE III) | 92 LF | 25.00 | 2,300.00 |
| 0086 | 4465000000-N | 1160 | TEMPORARY CRASH CUSHIONS | 2 EA | 4,800.00 | 9,600.00 |
| 0087 | 4490000000-E | 1170 | PORTABLE CONCRETE BARRIER (ANCHORED) | 670 LF | 26.00 | 17,420.00 |
| 0088 | 4510000000-N | SP | LAW ENFORCEMENT | 96 HR | 45.00 | 4,320.00 |
| 0089 | 4650000000-N | 1251 | TEMPORARY RAISED PAVEMENT MARKERS | 345 EA | 11.25 | 3,881.25 |

| Line # | ItemNumber | Sec # | Description | Quantity Unit | Unit Bid Price | Amount Bid |
|--------|--------------|-------|----------------------------------------------------------------|---------------|----------------|------------|
| 0090 | 4685000000-E | 1205 | THERMOPLASTIC PAVEMENT MARKING LINES (4", 90 MILS) | 48,785 LF | 0.61 | 29,758.85 |
| 0091 | 4686000000-E | 1205 | THERMOPLASTIC PAVEMENT MARKING LINES (4", 120 MILS) | 18,260 LF | 0.67 | 12,234.20 |
| 0092 | 4695000000-E | 1205 | THERMOPLASTIC PAVEMENT MARKING LINES (8", 90 MILS) | 9,701 LF | 1.05 | 10,186.05 |
| 0093 | 4697000000-E | 1205 | THERMOPLASTIC PAVEMENT MARKING LINES (8", 120 MILS) | 4,223 LF | 1.95 | 8,234.85 |
| 0094 | 4700000000-E | 1205 | THERMOPLASTIC PAVEMENT MARKING LINES (12", 90 MILS) | 1,007 LF | 3.70 | 3,725.90 |
| 0095 | 4710000000-E | 1205 | THERMOPLASTIC PAVEMENT MARKING LINES (24", 120 MILS) | 2,892 LF | 7.90 | 22,846.80 |
| 0096 | 4721000000-E | 1205 | THERMOPLASTIC PAVEMENT MARKING CHARACTER (120 MILS) | 110 EA | 152.00 | 16,720.00 |
| 0097 | 4725000000-E | 1205 | THERMOPLASTIC PAVEMENT MARKING SYMBOL (90 MILS) | 307 EA | 162.00 | 49,734.00 |
| 0098 | 4770000000-E | 1205 | COLD APPLIED PLASTIC PAVEMENT MARKING LINES, TYPE ** (4") (II) | 550 LF | 9.50 | 5,225.00 |
| 0099 | 4805000000-N | 1205 | COLD APPLIED PLASTIC PAVEMENT MARKING SYMBOL, TYPE ** (II) | 2 EA | 1,100.00 | 2,200.00 |
| 0100 | 4810000000-E | 1205 | PAINT PAVEMENT MARKING LINES (4") | 26,347 LF | 0.19 | 5,005.93 |
| 0101 | 4820000000-E | 1205 | PAINT PAVEMENT MARKING LINES (8") | 5,188 LF | 0.42 | 2,178.96 |
| 0102 | 4835000000-E | 1205 | PAINT PAVEMENT MARKING LINES (24") | 643 LF | 4.20 | 2,700.60 |
| 0103 | 4840000000-N | 1205 | PAINT PAVEMENT MARKING CHARACTER | 24 EA | 42.00 | 1,008.00 |
| 0104 | 4845000000-N | 1205 | PAINT PAVEMENT MARKING SYMBOL | 91 EA | 58.00 | 5,278.00 |
| 0105 | 4895000000-N | SP | GENERIC PAVEMENT MARKING ITEM IN LANE ROUTE SHIELDS | 6 EA | 1,865.00 | 11,190.00 |

| Line # | ItemNumber | Sec # | Description | Quantity Unit | Unit Bid Price | Amount Bid |
|--------|--------------|-------|------------------------------------|----------------|----------------|------------|
| 0106 | 4900000000-N | 1251 | PERMANENT RAISED PAVEMENT MARKERS | 1,530 EA | 10.25 | 15,682.50 |
| 0107 | 5255000000-N | 1413 | PORTABLE LIGHTING | Lump Sum LS | 150,000.00 | 150,000.00 |
| 0108 | 5325200000-E | 1510 | 2" WATER LINE | 417 LF | 38.00 | 15,846.00 |
| 0109 | 5325600000-E | 1510 | 6" WATER LINE | 163 LF | 135.00 | 22,005.00 |
| 0110 | 5326600000-E | 1510 | 16" WATER LINE | 429 LF | 225.00 | 96,525.00 |
| 0111 | 5329000000-E | SP | DUCTILE IRON WATER PIPE FITTINGS | 4,300 LB | 8.00 | 34,400.00 |
| 0112 | 5536000000-E | 1515 | 2" VALVE | 1 EA | 895.00 | 895.00 |
| 0113 | 5648000000-N | 1515 | RELOCATE WATER METER | 11 EA | 1,300.00 | 14,300.00 |
| 0114 | 5649000000-N | 1515 | RECONNECT WATER METER | 3 EA | 1,500.00 | 4,500.00 |
| 0115 | 5672000000-N | 1515 | RELOCATE FIRE HYDRANT | 1 EA | 4,000.00 | 4,000.00 |
| 0116 | 5685200000-E | 1515 | 16" LINE STOP WITH BYPASS | 4 EA | 22,000.00 | 88,000.00 |
| 0117 | 5800000000-E | 1530 | ABANDON 6" UTILITY PIPE | 160 LF | 15.00 | 2,400.00 |
| 0118 | 5810000000-E | 1530 | ABANDON 16" UTILITY PIPE | 425 LF | 20.00 | 8,500.00 |
| 0119 | 6000000000-E | 1605 | TEMPORARY SILT FENCE | 6,315 LF | 1.85 | 11,682.75 |
| 0120 | 6006000000-E | 1610 | STONE FOR EROSION CONTROL, CLASS A | 125 TON | 55.00 | 6,875.00 |
| 0121 | 6009000000-E | 1610 | STONE FOR EROSION CONTROL, CLASS B | 225 TON | 55.00 | 12,375.00 |
| 0122 | 6012000000-E | 1610 | SEDIMENT CONTROL STONE | 220 TON | 41.00 | 9,020.00 |
| 0123 | 6015000000-E | 1615 | TEMPORARY MULCHING | 7.5 ACR | 525.00 | 3,937.50 |
| 0124 | 6018000000-E | 1620 | SEED FOR TEMPORARY SEEDING | 400 LB | 2.65 | 1,060.00 |
| 0125 | 6021000000-E | 1620 | FERTILIZER FOR TEMPORARY SEEDING | 2 TON | 950.00 | 1,900.00 |

| Line # | ItemNumber | Sec # | Description | Quantity Unit | Unit Bid Price | Amount Bid |
|--------|--------------|-------|---------------------------------------------------------|---------------|----------------|------------|
| 0126 | 6024000000-E | 1622 | TEMPORARY SLOPE DRAINS | 200 LF | 13.25 | 2,650.00 |
| 0127 | 6029000000-E | SP | SAFETY FENCE | 200 LF | 2.00 | 400.00 |
| 0128 | 6030000000-E | 1630 | SILT EXCAVATION | 400 CY | 18.00 | 7,200.00 |
| 0129 | 6036000000-E | 1631 | MATTING FOR EROSION CONTROL | 29,900 SY | 1.58 | 47,242.00 |
| 0130 | 6037000000-E | SP | COIR FIBER MAT | 100 SY | 4.00 | 400.00 |
| 0131 | 6038000000-E | SP | PERMANENT SOIL REINFORCEMENT MAT | 350 SY | 3.50 | 1,225.00 |
| 0132 | 6042000000-E | 1632 | 1/4" HARDWARE CLOTH | 300 LF | 4.50 | 1,350.00 |
| 0133 | 6071010000-E | SP | WATTLE | 4,960 LF | 4.20 | 20,832.00 |
| 0134 | 6071020000-E | SP | POLYACRYLAMIDE (PAM) | 50 LB | 8.50 | 425.00 |
| 0135 | 6071030000-E | 1640 | COIR FIBER BAFFLE | 100 LF | 4.25 | 425.00 |
| 0136 | 6084000000-E | 1660 | SEEDING & MULCHING | 9 ACR | 1,725.00 | 15,525.00 |
| 0137 | 6087000000-E | 1660 | MOWING | 6 ACR | 130.00 | 780.00 |
| 0138 | 6090000000-E | 1661 | SEED FOR REPAIR SEEDING | 100 LB | 2.65 | 265.00 |
| 0139 | 6093000000-E | 1661 | FERTILIZER FOR REPAIR SEEDING | 0.25 TON | 950.00 | 237.50 |
| 0140 | 6096000000-E | 1662 | SEED FOR SUPPLEMENTAL SEEDING | 175 LB | 2.65 | 463.75 |
| 0141 | 6108000000-E | 1665 | FERTILIZER TOPDRESSING | 4.75 TON | 950.00 | 4,512.50 |
| 0142 | 6114500000-N | 1667 | SPECIALIZED HAND MOWING | 10 MHR | 95.00 | 950.00 |
| 0143 | 6117000000-N | SP | RESPONSE FOR EROSION CONTROL | 75 EA | 310.00 | 23,250.00 |
| 0144 | 6132000000-N | SP | GENERIC EROSION CONTROL ITEM CONCRETE WASHOUT STRUCTURE | 2 EA | 1,200.00 | 2,400.00 |
| 0145 | 7048500000-E | 1705 | PEDESTRIAN SIGNAL HEAD (16", 1 SECTION W/COUNTDOWN) | 18 EA | 680.00 | 12,240.00 |

| Line # | ItemNumber | Sec # | Description | Quantity Unit | Unit Bid Price | Amount Bid |
|--------|--------------|-------|----------------------------------------------|---------------|----------------|------------|
| 0146 | 7060000000-E | 1705 | SIGNAL CABLE | 12,180 LF | 1.05 | 12,789.00 |
| 0147 | 7120000000-E | 1705 | VEHICLE SIGNAL HEAD (12", 3 SECTION) | 64 EA | 665.00 | 42,560.00 |
| 0148 | 7132000000-E | 1705 | VEHICLE SIGNAL HEAD (12", 4 SECTION) | 12 EA | 830.00 | 9,960.00 |
| 0149 | 7252000000-E | 1710 | MESSENGER CABLE (1/4") | 170 LF | 4.25 | 722.50 |
| 0150 | 7264000000-E | 1710 | MESSENGER CABLE (3/8") | 5,480 LF | 5.80 | 31,784.00 |
| 0151 | 7288000000-E | 1715 | PAVED TRENCHING (***** (1, 2") | 50 LF | 40.00 | 2,000.00 |
| 0152 | 7288000000-E | 1715 | PAVED TRENCHING (***** (2, 2") | 70 LF | 43.00 | 3,010.00 |
| 0153 | 7300000000-E | 1715 | UNPAVED TRENCHING (***** (1, 2") | 9,050 LF | 6.85 | 61,992.50 |
| 0154 | 7300000000-E | 1715 | UNPAVED TRENCHING (***** (2, 2") | 200 LF | 9.00 | 1,800.00 |
| 0155 | 7300000000-E | 1715 | UNPAVED TRENCHING (***** (3, 2") | 570 LF | 10.65 | 6,070.50 |
| 0156 | 7300000000-E | 1715 | UNPAVED TRENCHING (***** (5, 2") | 140 LF | 15.75 | 2,205.00 |
| 0157 | 7300000000-E | 1715 | UNPAVED TRENCHING (***** (6, 2") | 10 LF | 20.00 | 200.00 |
| 0158 | 7300000000-E | 1715 | UNPAVED TRENCHING (***** (7, 2") | 40 LF | 22.00 | 880.00 |
| 0159 | 7300100000-E | 1715 | UNPAVED TRENCHING FOR TEMP- ORARY LEAD-IN | 90 LF | 6.00 | 540.00 |
| 0160 | 7301000000-E | 1715 | DIRECTIONAL DRILL (***** (2, 2") | 1,360 LF | 17.50 | 23,800.00 |
| 0161 | 7324000000-N | 1716 | JUNCTION BOX (STANDARD SIZE) | 123 EA | 345.00 | 42,435.00 |
| 0162 | 7348000000-N | 1716 | JUNCTION BOX (OVER-SIZED, HEA- VY DUTY) | 16 EA | 660.00 | 10,560.00 |

| Line # | ItemNumber | Sec # | Description | Quantity Unit | Unit Bid Price | Amount Bid |
|--------|--------------|-------|-------------------------------------------------------------------------------------|---------------|----------------|------------|
| 0163 | 7360000000-N | 1720 | WOOD POLE | 42 EA | 890.00 | 37,380.00 |
| 0164 | 7372000000-N | 1721 | GUY ASSEMBLY | 64 EA | 500.00 | 32,000.00 |
| 0165 | 7408000000-E | 1722 | 1" RISER WITH WEATHERHEAD | 7 EA | 260.00 | 1,820.00 |
| 0166 | 7420000000-E | 1722 | 2" RISER WITH WEATHERHEAD | 56 EA | 395.00 | 22,120.00 |
| 0167 | 7432000000-E | 1722 | 2" RISER WITH HEAT SHRINK TUBING | 16 EA | 410.00 | 6,560.00 |
| 0168 | 7444000000-E | 1725 | INDUCTIVE LOOP SAWCUT | 13,680 LF | 6.45 | 88,236.00 |
| 0169 | 7456000000-E | 1726 | LEAD-IN CABLE (***** (14-2) | 41,540 LF | 1.37 | 56,909.80 |
| 0170 | 7636000000-N | 1745 | SIGN FOR SIGNALS | 20 EA | 290.00 | 5,800.00 |
| 0171 | 7642100000-N | 1743 | TYPE I POST WITH FOUNDATION | 4 EA | 1,160.00 | 4,640.00 |
| 0172 | 7642200000-N | 1743 | TYPE II PEDESTAL WITH FOUNDATION | 14 EA | 1,575.00 | 22,050.00 |
| 0173 | 7684000000-N | 1750 | SIGNAL CABINET FOUNDATION | 16 EA | 835.00 | 13,360.00 |
| 0174 | 7686000000-N | 1752 | CONDUIT ENTRANCE INTO EXISTING FOUNDATION | 1 EA | 650.00 | 650.00 |
| 0175 | 7756000000-N | 1751 | CONTROLLER WITH CABINET (TYPE 2070L, BASE MOUNTED) | 16 EA | 14,200.00 | 227,200.00 |
| 0176 | 7780000000-N | 1751 | DETECTOR CARD (TYPE 2070L) | 66 EA | 105.00 | 6,930.00 |
| 0177 | 7901000000-N | 1753 | CABINET BASE EXTENDER | 16 EA | 415.00 | 6,640.00 |
| 0178 | 7980000000-N | SP | GENERIC SIGNAL ITEM 900 MHZ SERIAL/ETHERNET RADIO, USING EXISTING ANTENNA (S) | 1 EA | 2,650.00 | 2,650.00 |
| 0179 | 7980000000-N | SP | GENERIC SIGNAL ITEM 900 MHZ SERIAL/ETHERNET SPREAD SPECTRUM RADIO | 16 EA | 4,100.00 | 65,600.00 |
| 0180 | 7980000000-N | SP | GENERIC SIGNAL ITEM ETHERNET EDGE SWITCH | 19 EA | 1,725.00 | 32,775.00 |

Contract Item Sheets For C203788

| Line # | ItemNumber | Sec # | Description | Quantity Unit | Unit Bid Price | Amount Bid |
|-----------------------------------------------|--------------|-------|-------------------------------------------------|---------------|----------------|-----------------------|
| 0181 | 7980000000-N | SP | GENERIC SIGNAL ITEM REPLACE CONFLICT MONITOR | 1 EA | 1,315.00 | 1,315.00 |
| 0182 | 7980000000-N | SP | GENERIC SIGNAL ITEM REPLACE CONTROLLER | 1 EA | 2,500.00 | 2,500.00 |
| 0183 | 8802040000-E | SP | CIP GRAVITY RETAINING WALLS | 538 SF | 175.00 | 94,150.00 |
| TOTAL AMOUNT OF BID FOR ENTIRE PROJECT | | | | | | \$9,544,080.09 |

1407/May01/Q376980.653/D788814300000/E183

Contract No. C203788
County Union

Rev. 5-19-11

**EXECUTION OF CONTRACT
NON-COLLUSION AFFIDAVIT, DEBARMENT CERTIFICATION AND GIFT BAN CERTIFICATION**

CORPORATION

The Contractor being duly sworn, solemnly swears (or affirms) that neither he, nor any official, agent or employee has entered into any agreement, participated in any collusion, or otherwise taken any action which is in restraint of free competitive bidding in connection with this Contract, that the Contractor has not been convicted of violating N.C.G.S. § 133-24 within the last three years, and that the Contractor intends to do the work with its own bonafide employees or subcontractors and did not bid for the benefit of another contractor.

By submitting this Execution of Contract, Non-Collusion Affidavit and Debarment Certification, the Contractor is certifying his status under penalty of perjury under the laws of the United States in accordance with the Debarment Certification attached, provided that the Debarment Certification also includes any required statements concerning exceptions that are applicable.

N.C.G.S. § 133-32 and Executive Order 24 prohibit the offer to, or acceptance by, any State Employee of any gift from anyone with a contract with the State, or from any person seeking to do business with the State. By execution of any response in this procurement, you attest, for your entire organization and its employees or agents, that you are not aware that any such gift has been offered, accepted, or promised by any employees of your organization.

SIGNATURE OF CONTRACTOR

Sealand Contractors Corp.

Full name of Corporation

1708 North Caldwell Street, Charlotte, NC 28206

Address as Prequalified

Attest

Valerie Hargreaves
Secretary/~~Asst. Secy~~/~~Secy~~
Select appropriate title

By

Daniel Bree
President/~~Vice Pres~~/~~Asst. Pres~~/~~Gen. Mgr~~/~~Exec. Dir~~/~~Other~~
Select appropriate title

Valerie Hargreaves

Print or type Signer's name

Daniel Bree

Print or type Signer's name

CORPORATE SEAL

AFFIDAVIT MUST BE NOTARIZED

Subscribed and sworn to before me this the

27th day of APRIL 2017.

Danae R Kozlowski
Signature of Notary Public

of Union County

State of North Carolina

My Commission Expires: October 26, 2020

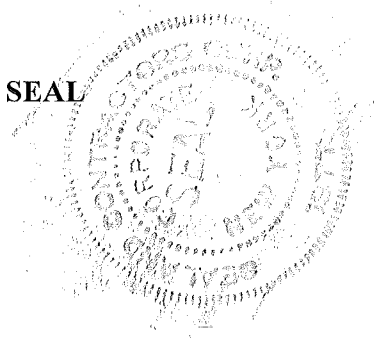
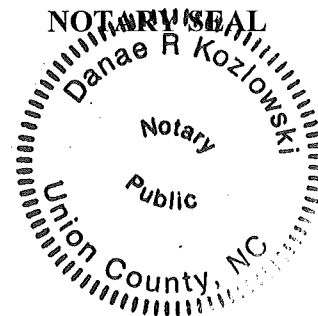

DEBARMENT CERTIFICATION

Conditions for certification:

1. The prequalified bidder shall provide immediate written notice to the Department if at any time the bidder learns that his certification was erroneous when he submitted his debarment certification or explanation filed with the Department, or has become erroneous because of changed circumstances.
2. The terms *covered transaction, debarred, suspended, ineligible, lower tier covered transaction, participant, person, primary covered transaction, principal, proposal, and voluntarily excluded*, as used in this provision, have the meanings set out in the Definitions and Coverage sections of the rules implementing Executive Order 12549. A copy of the Federal Rules requiring this certification and detailing the definitions and coverages may be obtained from the Contract Officer of the Department.
3. The prequalified bidder agrees by submitting this form, that he will not knowingly enter into any lower tier covered transaction with a person who is debarred, suspended, declared ineligible, or voluntarily excluded from participation in NCDOT contracts, unless authorized by the Department.
4. For Federal Aid projects, the prequalified bidder further agrees that by submitting this form he will include the Federal-Aid Provision titled *Required Contract Provisions Federal-Aid Construction Contract (Form FHWA PR 1273)* provided by the Department, without subsequent modification, in all lower tier covered transactions.
5. The prequalified bidder may rely upon a certification of a participant in a lower tier covered transaction that he is not debarred, suspended, ineligible, or voluntarily excluded from the covered transaction, unless he knows that the certification is erroneous. The bidder may decide the method and frequency by which he will determine the eligibility of his subcontractors.
6. Nothing contained in the foregoing shall be construed to require establishment of a system of records in order to render in good faith the certification required by this provision. The knowledge and information of a participant is not required to exceed that which is normally possessed by a prudent person in the ordinary course of business dealings.
7. Except as authorized in paragraph 6 herein, the Department may terminate any contract if the bidder knowingly enters into a lower tier covered transaction with a person who is suspended, debarred, ineligible, or voluntarily excluded from participation in this transaction, in addition to other remedies available by the Federal Government.

DEBARMENT CERTIFICATION

The prequalified bidder certifies to the best of his knowledge and belief, that he and his principals:

- a. Are not presently debarred, suspended, proposed for debarment, declared ineligible, or voluntarily excluded from covered transactions by any Federal department or agency;
- b. Have not within a three-year period preceding this proposal been convicted of or had a civil judgment rendered against them for commission of fraud or a criminal offense in connection with obtaining, attempting to obtain, or performing a public (Federal, State or local) transaction or contract under a public transaction; violation of Federal or State antitrust statutes or commission of embezzlement, theft, forgery, bribery, falsification or destruction of records; making false statements; or receiving stolen property;
- c. Are not presently indicted for or otherwise criminally or civilly charged by a governmental entity (Federal, State or local) with commission of any of the offenses enumerated in paragraph b. of this certification; and
- d. Have not within a three-year period preceding this proposal had one or more public transactions (Federal, State or local) terminated for cause or default.
- e. Will submit a revised Debarment Certification immediately if his status changes and will show in his bid proposal an explanation for the change in status.

If the prequalified bidder cannot certify that he is not debarred, he shall provide an explanation with this submittal. An explanation will not necessarily result in denial of participation in a contract.

Failure to submit a non-collusion affidavit and debarment certification will result in the prequalified bidder's bid being considered non-responsive.

Check here if an explanation is attached to this certification.

Contract No. C203788

County (ies): Union

ACCEPTED BY THE
DEPARTMENT OF TRANSPORTATION

DocuSigned by:
Ronald E. Davenport, Jr.
F81E6038A47A442...

Contract Officer

5/2/2017

Date

Execution of Contract and Bonds
Approved as to Form:

DocuSigned by:
Colin Justice
1889E4C5ADF14AE...

Attorney General

5/2/2017

Date

Signature Sheet (Bid - Acceptance by Department)

Contract No. C203788
County Union County
Bond No. 837070199

Rev 5-17-11

CONTRACT PAYMENT BOND

Date of Payment Bond Execution April 26, 2017
Name of Principal Contractor Sealand Contractors Corp.
Name of Surety: Liberty Mutual Insurance Company
Name of Contracting Body: **North Carolina Department of Transportation**
Raleigh, North Carolina
Amount of Bond: \$9,544,080.09
Contract ID No.: C203788
County Name: Union County

KNOW ALL MEN BY THESE PRESENTS, That we, the PRINCIPAL CONTRACTOR (hereafter, PRINCIPAL) and SURETY above named, are held and firmly bound unto the above named Contracting Body, hereinafter called the Contracting Body, in the penal sum of the amount stated above for the payment of which sum well and truly to be made, we bind ourselves, our heirs, executors, administrators, and successors, jointly and severally, firmly by these presents.

THE CONDITION OF THIS OBLIGATION IS SUCH, that whereas the principal entered into a certain contract with the Contracting Body, numbered as shown above and hereto attached:

NOW THEREFORE, if the principal shall promptly make payment to all persons supplying labor and material in the prosecution of the work provided for in said contract, and any and all duly authorized modifications of said contract that may hereafter be made, notice of which modifications to the surety being hereby waived, then this obligation to be void; otherwise to remain in full force and virtue.

IN WITNESS WHEREOF, the above-bound parties have executed this instrument under their several seals on the date indicated above, the name and corporate seal of each corporate party being hereto affixed and these presents duly signed by its undersigned representative, pursuant to authority of its governing body.

Contract No. C203788
County Union County

Rev 5-17-11

CONTRACT PAYMENT BOND

Affix Seal of Surety Company

Liberty Mutual Insurance Company

Print or type Surety Company Name

By Natalie M. Jimenez, Attorney-In-Fact

Print, stamp or type name of Attorney-in-Fact



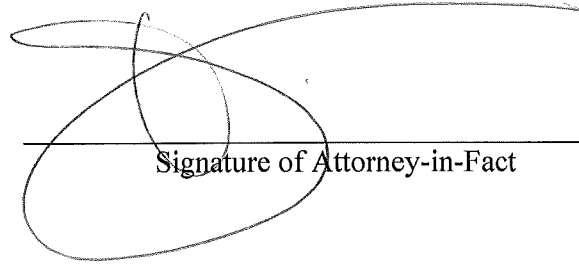

Signature of Attorney-in-Fact



Signature of Witness

Courtney Sprague, Witness

Print or type Signer's name

8 E. Main Street, Marcellus, NY 13108

Address of Attorney-in-Fact

INDIVIDUAL ACKNOWLEDGMENT

State of _____
County of _____

On this _____ day of _____, _____, before me personally appeared _____ known to me to be the person _____ described in and who executed the foregoing instrument, and _____ he _____ duly acknowledged to me that _____ he _____ executed the same.

Notary Public

CORPORATION ACKNOWLEDGMENT

State of NORTH CAROLINA
County of MECKLENBURG

On this 27th day of APRIL, 2017, before me personally appeared Daniel Bree to me known, who being by me duly sworn, did depose and say: that he/she resides at VICTOR, NY; that he/she is PRESIDENT of the corporation described in and which executed the foregoing instrument; that he/she knows the seal of said corporation; that the seal affixed to said instrument is such corporate seal; that it was so affixed by order of the Board of Directors of said corporation; and that he/she signed his/her name thereto by like order.

My commission expires October 26, 2020

Danae R Kozlowski

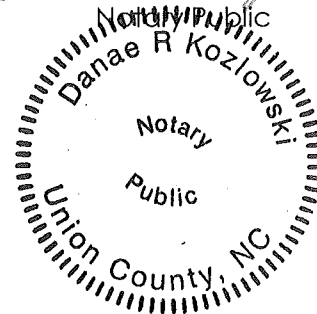

SURETY ACKNOWLEDGMENT

State of New York
County of Onondaga

On this 26th day of April, 2017, before me personally appeared Natalie M. Jimenez to me known, who being by me duly sworn, did depose and say: that he/she resides in the City of Syracuse, NY; that he/she is the Attorney-In-Fact of the above signed surety, the corporation described in and which executed the within instrument; that he/she knows the corporate seal of said corporation; that the seal affixed to said instrument is such corporate seal; that it was so affixed by order of the Board of Directors of said corporation; and that he/she signed his/her name thereto by like order.

Courtney P. Parody
Notary Public

COURTNEY PEPPER PARDY
Notary Public, State of New York
Qualified in Onondaga Co. No. 01PA6304020
My Commission Expires May 19, 2018

THIS POWER OF ATTORNEY IS NOT VALID UNLESS IT IS PRINTED ON RED BACKGROUND.

This Power of Attorney limits the acts of those named herein, and they have no authority to bind the Company except in the manner and to the extent herein stated.

Certificate No. 7586197

Liberty Mutual Insurance Company
The Ohio Casualty Insurance Company West American Insurance Company

POWER OF ATTORNEY

KNOWN ALL PERSONS BY THESE PRESENTS: That The Ohio Casualty Insurance Company is a corporation duly organized under the laws of the State of New Hampshire, that Liberty Mutual Insurance Company is a corporation duly organized under the laws of the State of Massachusetts, and West American Insurance Company is a corporation duly organized under the laws of the State of Indiana (herein collectively called the "Companies"), pursuant to and by authority herein set forth, does hereby name, constitute and appoint, Courtney P. Sprague; Edward J. Reagan; Francis A. Lowther; Monique Laroche; Natalie M. Jimenez; Robert B. Parrish

all of the city of Marcellus, state of NY each individually if there be more than one named, its true and lawful attorney-in-fact to make, execute, seal, acknowledge and deliver, for and on its behalf as surety and as its act and deed, any and all undertakings, bonds, recognizances and other surety obligations, in pursuance of these presents and shall be as binding upon the Companies as if they have been duly signed by the president and attested by the secretary of the Companies in their own proper persons.

IN WITNESS WHEREOF, this Power of Attorney has been subscribed by an authorized officer or official of the Companies and the corporate seals of the Companies have been affixed thereto this 5th day of January, 2017.



The Ohio Casualty Insurance Company
Liberty Mutual Insurance Company
West American Insurance Company

By: David M. Carey
David M. Carey, Assistant Secretary

STATE OF PENNSYLVANIA ss
COUNTY OF MONTGOMERY

On this 5th day of January, 2017, before me personally appeared David M. Carey, who acknowledged himself to be the Assistant Secretary of Liberty Mutual Insurance Company, The Ohio Casualty Company, and West American Insurance Company, and that he, as such, being authorized so to do, execute the foregoing instrument for the purposes therein contained by signing on behalf of the corporations by himself as a duly authorized officer.

IN WITNESS WHEREOF, I have hereunto subscribed my name and affixed my notarial seal at King of Prussia, Pennsylvania, on the day and year first above written.



COMMONWEALTH OF PENNSYLVANIA
Notarial Seal
Teresa Pastella, Notary Public
Upper Merion Twp., Montgomery County
My Commission Expires March 28, 2017
Member, Pennsylvania Association of Notaries

By: Teresa Pastella
Teresa Pastella, Notary Public

This Power of Attorney is made and executed pursuant to and by authority of the following By-laws and Authorizations of The Ohio Casualty Insurance Company, Liberty Mutual Insurance Company, and West American Insurance Company which resolutions are now in full force and effect reading as follows:

ARTICLE IV – OFFICERS – Section 12. Power of Attorney. Any officer or other official of the Corporation authorized for that purpose in writing by the Chairman or the President, and subject to such limitation as the Chairman or the President may prescribe, shall appoint such attorneys-in-fact, as may be necessary to act in behalf of the Corporation to make, execute, seal, acknowledge and deliver as surety any and all undertakings, bonds, recognizances and other surety obligations. Such attorneys-in-fact, subject to the limitations set forth in their respective powers of attorney, shall have full power to bind the Corporation by their signature and execution of any such instruments and to attach thereto the seal of the Corporation. When so executed, such instruments shall be as binding as if signed by the President and attested to by the Secretary. Any power or authority granted to any representative or attorney-in-fact under the provisions of this article may be revoked at any time by the Board, the Chairman, the President or by the officer or officers granting such power or authority.

ARTICLE XIII – Execution of Contracts – SECTION 5. Surety Bonds and Undertakings. Any officer of the Company authorized for that purpose in writing by the chairman or the president, and subject to such limitations as the chairman or the president may prescribe, shall appoint such attorneys-in-fact, as may be necessary to act in behalf of the Company to make, execute, seal, acknowledge and deliver as surety any and all undertakings, bonds, recognizances and other surety obligations. Such attorneys-in-fact subject to the limitations set forth in their respective powers of attorney, shall have full power to bind the Company by their signature and execution of any such instruments and to attach thereto the seal of the Company. When so executed such instruments shall be as binding as if signed by the president and attested by the secretary.

Certificate of Designation – The President of the Company, acting pursuant to the Bylaws of the Company, authorizes David M. Carey, Assistant Secretary to appoint such attorneys-in-fact as may be necessary to act on behalf of the Company to make, execute, seal, acknowledge and deliver as surety any and all undertakings, bonds, recognizances and other surety obligations.

Authorization – By unanimous consent of the Company's Board of Directors, the Company consents that facsimile or mechanically reproduced signature of any assistant secretary of the Company, wherever appearing upon a certified copy of any power of attorney issued by the Company in connection with surety bonds, shall be valid and binding upon the Company with the same force and effect as though manually affixed.

I, Renee C. Llewellyn, the undersigned, Assistant Secretary, The Ohio Casualty Insurance Company, Liberty Mutual Insurance Company, and West American Insurance Company do hereby certify that the original power of attorney of which the foregoing is a full, true and correct copy of the Power of Attorney executed by said Companies, is in full force and effect and has not been revoked.

IN TESTIMONY WHEREOF, I have hereunto set my hand and affixed the seals of said Companies this 26 day of April, 20 17.



By: Renee C. Llewellyn
Renee C. Llewellyn, Assistant Secretary

Not valid for mortgage, note, loan, letter of credit, currency rate, interest rate or residual value guarantees.

To confirm the validity of this Power of Attorney call 1-610-832-8240 between 9:00 am and 4:30 pm EST on any business day.



LIBERTY MUTUAL INSURANCE COMPANY
 FINANCIAL STATEMENT — DECEMBER 31, 2016

| Assets | Liabilities |
|-----------------------------------------------|---------------------------------------------|
| Cash and Bank Deposits | Unearned Premiums..... |
| \$1,092,914,837 | \$6,929,723,299 |
| *Bonds — U.S Government | Reserve for Claims and Claims Expense |
| 1,406,763,970 | 17,233,877,300 |
| *Other Bonds..... | Funds Held Under Reinsurance Treaties..... |
| 11,379,916,523 | 208,362,823 |
| *Stocks | Reserve for Dividends to Policyholders..... |
| 10,349,761,988 | 944,909 |
| Real Estate..... | Additional Statutory Reserve |
| 290,265,760 | 39,649,905 |
| Agents' Balances or Uncollected Premiums..... | Reserve for Commissions, Taxes and |
| 4,709,977,463 | Other Liabilities |
| Accrued Interest and Rents..... | <u>3,061,117,958</u> |
| 112,757,395 | Total |
| Other Admitted Assets..... | <u>\$27,473,676,194</u> |
| <u>14,659,523,751</u> | Special Surplus Funds..... |
| Total Admitted Assets | \$95,257,334 |
| <u>\$44,001,881,687</u> | Capital Stock..... |
| | 10,000,000 |
| | Paid in Surplus |
| | 9,229,250,104 |
| | Unassigned Surplus..... |
| | 7,193,698,055 |
| | Surplus to Policyholders..... |
| | <u>16,528,205,493</u> |
| | Total Liabilities and Surplus..... |
| | <u>\$44,001,881,687</u> |



* Bonds are stated at amortized or investment value; Stocks at Association Market Values.
 The foregoing financial information is taken from Liberty Mutual Insurance Company's financial statement filed with the state of Massachusetts Department of Insurance.

I, TIM MIKOLAJEWSKI, Assistant Secretary of Liberty Mutual Insurance Company, do hereby certify that the foregoing is a true, and correct statement of the Assets and Liabilities of said Corporation, as of December 31, 2016, to the best of my knowledge and belief.

IN WITNESS WHEREOF, I have hereunto set my hand and affixed the seal of said Corporation at Seattle, Washington, this 23rd day of March, 2017.

TAMikolajewski

Assistant Secretary

Contract No. C203788
County Union County

Rev 5-17-11

Bond No. 837070199

CONTRACT PERFORMANCE BOND

Date of Performance Bond Execution: April 26, 2017
Name of Principal Contractor: Sealand Contractors Corp.
Name of Surety: Liberty Mutual Insurance Company
Name of Contracting Body: **North Carolina Department of Transportation**
Raleigh, North Carolina
Amount of Bond: \$9,544,080.09
Contract ID No.: C203788
County Name: Union County

KNOW ALL MEN BY THESE PRESENTS, That we, the PRINCIPAL CONTRACTOR (hereafter, PRINCIPAL) and SURETY above named, are held and firmly bound unto the above named Contracting Body, hereinafter called the Contracting Body, in the penal sum of the amount stated above for the payment of which sum well and truly to be made, we bind ourselves, our heirs, executors, administrators, and successors, jointly and severally, firmly by these presents.

THE CONDITION OF THIS OBLIGATION IS SUCH, that whereas the principal entered into a certain contract with the Contracting Body, numbered as shown above and hereto attached:

NOW THEREFORE, if the principal shall well and truly perform and fulfill all the undertakings, covenants, terms, conditions, and agreements of said contract during the original term of said contract and any extensions thereof that may be granted by the Contracting Body, with or without notice to the Surety, and during the life of any guaranty required under the contract, and shall also well and truly perform and fulfill all the undertakings, covenants, terms, conditions, and agreements of any and all duly authorized modifications of said contract that may hereafter be made, notice of which modifications to the surety being hereby waived, then this obligation to be void; otherwise to remain in full force and virtue.

IN WITNESS WHEREOF, the above-bound parties have executed this instrument under their several seals on the date indicated above, the name and corporate seal of each corporate party being hereto affixed and these presents duly signed by its undersigned representative, pursuant to authority of its governing body.

Contract No. C203788
County Union County

Rev 5-17-11

CONTRACT PERFORMANCE BOND

Affix Seal of Surety Company

Liberty Mutual Insurance Company

Print or type Surety Company Name

By Natalie M. Jimenez, Attorney-In-Fact

Print, stamp or type name of Attorney-in-Fact

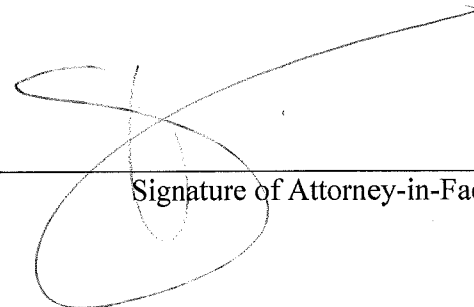

Signature of Attorney-in-Fact



Courtney Sprague

Signature of Witness

Courtney Sprague, Witness

Print or type Signer's name

8 E. Main Street, Marcellus, NY 13108

Address of Attorney-in-Fact

Contract No. C203788
County Union

Rev 5-17-11

CONTRACT PERFORMANCE BOND

CORPORATION

SIGNATURE OF CONTRACTOR (Principal)

Sealand Contractors Corp.

Full name of Corporation

1708 North Caldwell Street, Charlotte, NC 28206

Address as prequalified

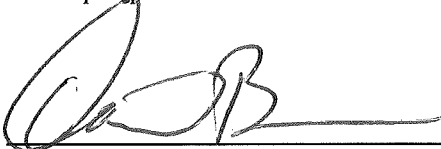
By 
Signature of President, ~~XXXXXX~~ ~~XXXXXX~~ ~~XXXXXX~~ ~~XXXXXX~~ ~~XXXXXX~~ ~~XXXXXX~~ ~~XXXXXX~~ ~~XXXXXX~~ ~~XXXXXX~~ ~~XXXXXX~~
Select appropriate title

Daniel Bree
Print or type Signer's name

Affix Corporate Seal

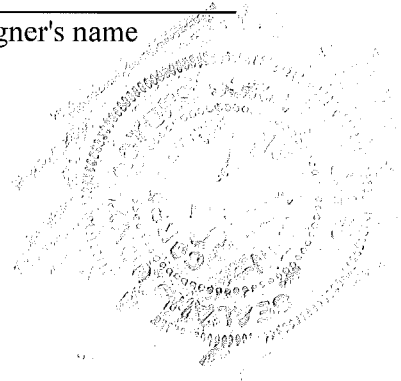

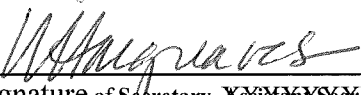
Attest 
Signature of Secretary, ~~XXXXXX~~ ~~XXXXXX~~ ~~XXXXXX~~ ~~XXXXXX~~ ~~XXXXXX~~ ~~XXXXXX~~ ~~XXXXXX~~ ~~XXXXXX~~ ~~XXXXXX~~ ~~XXXXXX~~
Select appropriate title

Valerie Hargreaves
Print or type Signer's name

INDIVIDUAL ACKNOWLEDGMENT

State of _____
County of _____

On this _____ day of _____, _____, before me personally appeared _____ known to me to be the person _____ described in and who executed the foregoing instrument, and _____ he _____ duly acknowledged to me that _____ he _____ executed the same.

Notary Public

CORPORATION ACKNOWLEDGMENT

State of NORTH CAROLINA
County of MECKLENBURG

On this 27th day of APRIL, 2017, before me personally appeared Daniel Bree to me known, who being by me duly sworn, did depose and say: that he/she resides at VECTOR, NY; that he/she is PRESIDENT of the corporation described in and which executed the foregoing instrument; that he/she knows the seal of said corporation; that the seal affixed to said instrument is such corporate seal; that it was so affixed by order of the Board of Directors of said corporation; and that he/she signed his/her name thereto by like order.

My commission expires October 26, 2020

Danae R. Kozlowski
Notary Public
Danae R. Kozlowski
Notary
Public
Union County, NC

SURETY ACKNOWLEDGMENT

State of New York
County of Onondaga

On this 26th day of April, 2017, before me personally appeared Natalie M. Jimenez to me known, who being by me duly sworn, did depose and say: that he/she resides in the City of Syracuse, NY; that he/she is the Attorney-In-Fact of the above signed surety, the corporation described in and which executed the within instrument; that he/she knows the corporate seal of said corporation; that the seal affixed to said instrument is such corporate seal; that it was so affixed by order of the Board of Directors of said corporation; and that he/she signed his/her name thereto by like order.

Courtney P. Paroly
Notary Public

COURTNEY PEPPER PARDY
Notary Public, State of New York
Qualified in Onondaga Co. No. 01PA6304020
My Commission Expires May 19, 2018

THIS POWER OF ATTORNEY IS NOT VALID UNLESS IT IS PRINTED ON RED BACKGROUND.

This Power of Attorney limits the acts of those named herein, and they have no authority to bind the Company except in the manner and to the extent herein stated.

Certificate No. 7586199

Liberty Mutual Insurance Company
The Ohio Casualty Insurance Company West American Insurance Company

POWER OF ATTORNEY

KNOWN ALL PERSONS BY THESE PRESENTS: That The Ohio Casualty Insurance Company is a corporation duly organized under the laws of the State of New Hampshire, that Liberty Mutual Insurance Company is a corporation duly organized under the laws of the State of Massachusetts, and West American Insurance Company is a corporation duly organized under the laws of the State of Indiana (herein collectively called the "Companies"), pursuant to and by authority herein set forth, does hereby name, constitute and appoint, Courtney P. Sprague; Edward J. Reagan; Francis A. Lowther; Monique Laroche; Natalie M. Jimenez; Robert B. Parrish

all of the city of Marcellus, state of NY each individually if there be more than one named, its true and lawful attorney-in-fact to make, execute, seal, acknowledge and deliver, for and on its behalf as surety and as its act and deed, any and all undertakings, bonds, recognizances and other surety obligations, in pursuance of these presents and shall be as binding upon the Companies as if they have been duly signed by the president and attested by the secretary of the Companies in their own proper persons.

IN WITNESS WHEREOF, this Power of Attorney has been subscribed by an authorized officer or official of the Companies and the corporate seals of the Companies have been affixed thereto this 5th day of January, 2017.



The Ohio Casualty Insurance Company
Liberty Mutual Insurance Company
West American Insurance Company

By: David M. Carey
David M. Carey, Assistant Secretary

STATE OF PENNSYLVANIA ss
COUNTY OF MONTGOMERY

On this 5th day of January, 2017, before me personally appeared David M. Carey, who acknowledged himself to be the Assistant Secretary of Liberty Mutual Insurance Company, The Ohio Casualty Company, and West American Insurance Company, and that he, as such, being authorized so to do, execute the foregoing instrument for the purposes therein contained by signing on behalf of the corporations by himself as a duly authorized officer.

IN WITNESS WHEREOF, I have hereunto subscribed my name and affixed my notarial seal at King of Prussia, Pennsylvania, on the day and year first above written.



COMMONWEALTH OF PENNSYLVANIA
Notarial Seal
Teresa Pastella, Notary Public
Upper Merion Twp., Montgomery County
My Commission Expires March 28, 2017
Member, Pennsylvania Association of Notaries

By: Teresa Pastella
Teresa Pastella, Notary Public

This Power of Attorney is made and executed pursuant to and by authority of the following By-laws and Authorizations of The Ohio Casualty Insurance Company, Liberty Mutual Insurance Company, and West American Insurance Company which resolutions are now in full force and effect reading as follows:

ARTICLE IV – OFFICERS – Section 12. Power of Attorney. Any officer or other official of the Corporation authorized for that purpose in writing by the Chairman or the President, and subject to such limitation as the Chairman or the President may prescribe, shall appoint such attorneys-in-fact, as may be necessary to act in behalf of the Corporation to make, execute, seal, acknowledge and deliver as surety any and all undertakings, bonds, recognizances and other surety obligations. Such attorneys-in-fact, subject to the limitations set forth in their respective powers of attorney, shall have full power to bind the Corporation by their signature and execution of any such instruments and to attach thereto the seal of the Corporation. When so executed, such instruments shall be as binding as if signed by the President and attested to by the Secretary. Any power or authority granted to any representative or attorney-in-fact under the provisions of this article may be revoked at any time by the Board, the Chairman, the President or by the officer or officers granting such power or authority.

ARTICLE XIII – Execution of Contracts – SECTION 5. Surety Bonds and Undertakings. Any officer of the Company authorized for that purpose in writing by the chairman or the president, and subject to such limitations as the chairman or the president may prescribe, shall appoint such attorneys-in-fact, as may be necessary to act in behalf of the Company to make, execute, seal, acknowledge and deliver as surety any and all undertakings, bonds, recognizances and other surety obligations. Such attorneys-in-fact subject to the limitations set forth in their respective powers of attorney, shall have full power to bind the Company by their signature and execution of any such instruments and to attach thereto the seal of the Company. When so executed such instruments shall be as binding as if signed by the president and attested by the secretary.

Certificate of Designation – The President of the Company, acting pursuant to the Bylaws of the Company, authorizes David M. Carey, Assistant Secretary to appoint such attorneys-in-fact as may be necessary to act on behalf of the Company to make, execute, seal, acknowledge and deliver as surety any and all undertakings, bonds, recognizances and other surety obligations.

Authorization – By unanimous consent of the Company's Board of Directors, the Company consents that facsimile or mechanically reproduced signature of any assistant secretary of the Company, wherever appearing upon a certified copy of any power of attorney issued by the Company in connection with surety bonds, shall be valid and binding upon the Company with the same force and effect as though manually affixed.

I, Renee C. Llewellyn, the undersigned, Assistant Secretary, The Ohio Casualty Insurance Company, Liberty Mutual Insurance Company, and West American Insurance Company do hereby certify that the original power of attorney of which the foregoing is a full, true and correct copy of the Power of Attorney executed by said Companies, is in full force and effect and has not been revoked.

IN TESTIMONY WHEREOF, I have hereunto set my hand and affixed the seals of said Companies this 26 day of April, 20 17.



By: Renee C. Llewellyn
Renee C. Llewellyn, Assistant Secretary

Not valid for mortgage, note, loan, letter of credit, currency rate, interest rate or residual value guarantees.

To confirm the validity of this Power of Attorney call 1-610-832-8240 between 9:00 am and 4:30 pm EST on any business day.



LIBERTY MUTUAL INSURANCE COMPANY
FINANCIAL STATEMENT — DECEMBER 31, 2016

| Assets | Liabilities |
|------------------------------------------------|----------------------------------------------|
| Cash and Bank Deposits | Unearned Premiums |
| \$1,092,914,837 | \$6,929,723,299 |
| *Bonds — U.S Government | Reserve for Claims and Claims Expense |
| 1,406,763,970 | 17,233,877,300 |
| *Other Bonds | Funds Held Under Reinsurance Treaties |
| 11,379,916,523 | 208,362,823 |
| *Stocks | Reserve for Dividends to Policyholders |
| 10,349,761,988 | 944,909 |
| Real Estate | Additional Statutory Reserve |
| 290,265,760 | 39,649,905 |
| Agents' Balances or Uncollected Premiums | Reserve for Commissions, Taxes and |
| 4,709,977,463 | Other Liabilities |
| Accrued Interest and Rents | <u>3,061,117,958</u> |
| 112,757,395 | Total |
| Other Admitted Assets | \$27,473,676,194 |
| <u>14,659,523,751</u> | Special Surplus Funds |
| Total Admitted Assets | \$95,257,334 |
| <u>\$44,001,881,687</u> | Capital Stock |
| | 10,000,000 |
| | Paid in Surplus |
| | 9,229,250,104 |
| | Unassigned Surplus |
| | 7,193,698,055 |
| | Surplus to Policyholders |
| | <u>16,528,205,493</u> |
| | Total Liabilities and Surplus |
| | <u>\$44,001,881,687</u> |



* Bonds are stated at amortized or investment value; Stocks at Association Market Values.
The foregoing financial information is taken from Liberty Mutual Insurance Company's financial statement filed with the state of Massachusetts Department of Insurance.

I, TIM MIKOLAJEWSKI, Assistant Secretary of Liberty Mutual Insurance Company, do hereby certify that the foregoing is a true, and correct statement of the Assets and Liabilities of said Corporation, as of December 31, 2016, to the best of my knowledge and belief.

IN WITNESS WHEREOF, I have hereunto set my hand and affixed the seal of said Corporation at Seattle, Washington, this 23rd day of March, 2017.

TAMIKOLAJEWSKI

Assistant Secretary