

STATE OF NORTH CAROLINA
DEPARTMENT OF TRANSPORTATION
RALEIGH, N.C.

C204837

CONTRACT AND
CONTRACT BONDS
FOR CONTRACT NO. C204837

WBS 34853.3.3 STATE FUNDED

T.I.P NO. U-2729

COUNTY OF FORSYTH

THIS IS THE ROADWAY & STRUCTURE CONTRACT

ROUTE NUMBER LENGTH 0.767 MILES

LOCATION SR-1672 (HANES MILL ROAD) FROM MUSEUM DRIVE TO SR-4000
(UNIVERSITY PARKWAY) IN WINSTON-SALEM.

CONTRACTOR CATON CONSTRUCTION GROUP INC

ADDRESS P.O. BOX 4488

CHARLOTTESVILLE, VA 22905

BIDS OPENED JUNE 20, 2023

CONTRACT EXECUTION 07/21/2023

STATE OF NORTH CAROLINA
DEPARTMENT OF TRANSPORTATION
RALEIGH, N.C.

PROPOSAL

DATE AND TIME OF BID OPENING: **Jun 20, 2023 AT 02:00 PM**

CONTRACT ID C204837
WBS 34853.3.3

FEDERAL-AID NO. STATE FUNDED
COUNTY FORSYTH
T.I.P NO. U-2729
MILES 0.767
ROUTE NO.
LOCATION SR-1672 (HANES MILL ROAD) FROM MUSEUM DRIVE TO SR-4000
(UNIVERSITY PARKWAY) IN WINSTON-SALEM.

TYPE OF WORK GRADING, DRAINAGE, PAVING, SIGNALS, AND STRUCTURE.

NOTICE:

ALL BIDDERS SHALL COMPLY WITH ALL APPLICABLE LAWS REGULATING THE PRACTICE OF GENERAL CONTRACTING AS CONTAINED IN CHAPTER 87 OF THE GENERAL STATUTES OF NORTH CAROLINA WHICH REQUIRES THE BIDDER TO BE LICENSED BY THE N.C. LICENSING BOARD FOR CONTRACTORS WHEN BIDDING ON ANY NON-FEDERAL AID PROJECT WHERE THE BID IS \$30,000 OR MORE, EXCEPT FOR CERTAIN SPECIALTY WORK AS DETERMINED BY THE LICENSING BOARD. BIDDERS SHALL ALSO COMPLY WITH ALL OTHER APPLICABLE LAWS REGULATING THE PRACTICES OF ELECTRICAL, PLUMBING, HEATING AND AIR CONDITIONING AND REFRIGERATION CONTRACTING AS CONTAINED IN CHAPTER 87 OF THE GENERAL STATUTES OF NORTH CAROLINA. NOTWITHSTANDING THESE LIMITATIONS ON BIDDING, THE BIDDER WHO IS AWARDED ANY FEDERAL - AID FUNDED PROJECT SHALL COMPLY WITH CHAPTER 87 OF THE GENERAL STATUTES OF NORTH CAROLINA FOR LICENSING REQUIREMENTS WITHIN 60 CALENDAR DAYS OF BID OPENING.

BIDS WILL BE RECEIVED AS SHOWN BELOW:

THIS IS A ROADWAY & STRUCTURE PROPOSAL

5% BID BOND OR BID DEPOSIT REQUIRED

**PROPOSAL FOR THE CONSTRUCTION OF
CONTRACT No. C204837 IN FORSYTH COUNTY, NORTH CAROLINA
DEPARTMENT OF TRANSPORTATION,
RALEIGH, NORTH CAROLINA**

The Bidder has carefully examined the location of the proposed work to be known as Contract No. **C204837** has carefully examined the plans and specifications, which are acknowledged to be part of the proposal, the special provisions, the proposal, the form of contract, and the forms of contract payment bond and contract performance bond; and thoroughly understands the stipulations, requirements and provisions. The undersigned bidder agrees to be bound upon his execution of the bid and subsequent award to him by the Board of Transportation in accordance with this proposal to provide the necessary contract payment bond and contract performance bond within fourteen days after the written notice of award is received by him. The undersigned Bidder further agrees to provide all necessary machinery, tools, labor, and other means of construction; and to do all the work and to furnish all materials, except as otherwise noted, necessary to perform and complete the said contract in accordance with *the 2018 Standard Specifications for Roads and Structures* by the dates(s) specified in the Project Special Provisions and in accordance with the requirements of the Engineer, and at the unit or lump sum prices, as the case may be, for the various items given on the sheets contained herein.

The Bidder shall provide and furnish all the materials, machinery, implements, appliances and tools, and perform the work and required labor to construct and complete State Highway Contract No. **C204837** in **Forsyth County**, for the unit or lump sum prices, as the case may be, bid by the Bidder in his bid and according to the proposal, plans, and specifications prepared by said Department, which proposal, plans, and specifications show the details covering this project, and hereby become a part of this contract.

The published volume entitled *North Carolina Department of Transportation, Raleigh, Standard Specifications for Roads and Structures, January 2018* with all amendments and supplements thereto, is by reference incorporated into and made a part of this contract; that, except as herein modified, all the construction and work included in this contract is to be done in accordance with the specifications contained in said volume, and amendments and supplements thereto, under the direction of the Engineer.

If the proposal is accepted and the award is made, the contract is valid only when signed either by the Contract Officer or such other person as may be designated by the Secretary to sign for the Department of Transportation. The conditions and provisions herein cannot be changed except over the signature of the said Contract Officer.

The quantities shown in the itemized proposal for the project are considered to be approximate only and are given as the basis for comparison of bids. The Department of Transportation may increase or decrease the quantity of any item or portion of the work as may be deemed necessary or expedient.

An increase or decrease in the quantity of an item will not be regarded as sufficient ground for an increase or decrease in the unit prices, nor in the time allowed for the completion of the work, except as provided for the contract.

Accompanying this bid is a bid bond secured by a corporate surety, or certified check payable to the order of the Department of Transportation, for five percent of the total bid price, which deposit is to be forfeited as liquidated damages in case this bid is accepted and the Bidder shall fail to provide the required payment and performance bonds with the Department of Transportation, under the condition of this proposal, within 14 calendar days after the written notice of award is received by him, as provided in the *Standard Specifications*; otherwise said deposit will be returned to the Bidder.



State Contract Officer

DocuSigned by:

Ronald Elton Davenport, Jr.

F81B6038A47A442...

05/19/2023

TABLE OF CONTENTS

**COVER SHEET
PROPOSAL SHEET**

PROJECT SPECIAL PROVISIONS

CONTRACTOR PREQUALIFICATION:..... G-1

INTERESTED PARTIES LIST: G-1

LIABILITY INSURANCE:..... G-2

CONTRACT TIME AND LIQUIDATED DAMAGES: G-2

INTERMEDIATE CONTRACT TIME NUMBER 1 AND LIQUIDATED DAMAGES: G-3

INTERMEDIATE CONTRACT TIME NUMBER 2 AND LIQUIDATED DAMAGES: G-3

INTERMEDIATE CONTRACT TIME NUMBER 3 AND LIQUIDATED DAMAGES: G-5

INTERMEDIATE CONTRACT TIME NUMBER 4 AND LIQUIDATED DAMAGES: G-6

INTERMEDIATE CONTRACT TIME NUMBER 5 AND LIQUIDATED DAMAGES: G-7

INTERMEDIATE CONTRACT TIME NUMBER 6 AND LIQUIDATED DAMAGES: G-7

INTERMEDIATE CONTRACT TIME NUMBER 7 AND LIQUIDATED DAMAGES FOR
FAILURE TO REPAIR A DAMAGED FIBER OPTIC COMMUNICATIONS CABLE AND
RESTORE COMMUNICATION..... G-7

INTERMEDIATE CONTRACT TIME NUMBERS 8 AND 9 FOR FAILURE TO
REESTABLISH ITS FIBER COMMUNICATIONS G-7

PERMANENT VEGETATION ESTABLISHMENT:..... G-8

DELAY IN RIGHT OF ENTRY:..... G-9

MAJOR CONTRACT ITEMS: G-9

SPECIALTY ITEMS:..... G-9

FUEL PRICE ADJUSTMENT:..... G-9

STEEL PRICE ADJUSTMENT:..... G-11

SCHEDULE OF ESTIMATED COMPLETION PROGRESS:..... G-21

MINORITY BUSINESS ENTERPRISE AND WOMEN BUSINESS ENTERPRISE:..... G-21

CONTRACTOR'S LICENSE REQUIREMENTS: G-36

RESTRICTIONS ON ITS EQUIPMENT AND SERVICES:..... G-36

USE OF UNMANNED AIRCRAFT SYSTEM (UAS): G-37

EQUIPMENT IDLING GUIDELINES:..... G-37

SUBSURFACE INFORMATION:..... G-38

PORTABLE CONCRETE BARRIER - (Partial Payments for Materials):..... G-38

REMOVABLE PAVEMENT MARKINGS - (Partial Payments for Materials):..... G-38

MAINTENANCE OF THE PROJECT: G-38

ELECTRONIC BIDDING:..... G-39

AWARD LIMITS: G-40

TWELVE MONTH GUARANTEE: G-40

OUTSOURCING OUTSIDE THE USA:..... G-41

EROSION AND SEDIMENT CONTROL/STORMWATER CERTIFICATION: G-41

PROCEDURE FOR MONITORING BORROW PIT DISCHARGE:..... G-46

ROADWAY..... R-1

STANDARD SPECIAL PROVISIONS

AVAILABILITY FUNDS – TERMINATION OF CONTRACTS SSP-1
 NCDOT GENERAL SEED SPECIFICATION FOR SEED QUALITY SSP-2
 ERRATA..... SSP-5
 PLANT AND PEST QUARANTINES SSP-13
 MINIMUM WAGES SSP-14
 TITLE VI AND NONDISCRIMINATION SSP-15
 ON-THE-JOB TRAINING SSP-23

UNIT PROJECT SPECIAL PROVISIONS

GEOTECHNICALGT-0.1
 TRAFFIC CONTROL TC-1
 UTILITY CONSTRUCTION UC-1
 UTILITY BY OTHERS.....UBO-1
 EROSION CONTROL EC-1
 TRAFFIC SIGNALS TS-1
 STRUCTURES ST-1

PROPOSAL ITEM SHEET

ITEM SHEET(S)

PROJECT SPECIAL PROVISIONS**GENERAL****CONTRACTOR PREQUALIFICATION:**

(10-18-22)

102

SP1 G01

Revise the *2018 Standard Specifications* as follows:

Page 1-10, Subarticle 102-2(A) Bidder Prequalification, lines 30-31, delete and replace the first sentence with the following:

Prospective bidders shall obtain prequalification approval at least two business days prior to any letting in which they intend to submit a bid. It is recommended that the prospective bidder file all required statements and documents with the State Prequalifications Engineer no less than 4 weeks before a given letting.

Page 1-11, Subarticle 102-2(B) Purchase Order Bidder Prequalification, lines 16-18, delete and replace the first sentence with the following:

Prospective bidders shall obtain prequalification approval at least two business days prior to any letting in which they intend to submit a bid. It is recommended that the applicant file all required statements and documents with the State Prequalifications Engineer no less than 4 weeks before a given bid opening for their bid to be considered.

Page 1-11, Subarticle 102-2(C) Subcontractor Prequalification, lines 44-45, delete and replace the first sentence with the following:

The subcontractor shall file all required statements and documents with the State Prequalifications Engineer no less than 4 weeks before beginning work.

Page 1-12, Subarticle 102-2(E) Renewal and Requalification, lines 38-40, delete and replace the first sentence with the following:

It is recommended that the renewing or requalifying firm file all required statements and documents with the State Prequalifications Engineer no less than 4 weeks before a given letting for their bid to be considered.

INTERESTED PARTIES LIST:

(6-21-22)(Rev. 7-19-22)

102

SP1 G02

Revise the *2018 Standard Specifications* as follows:

Page 1-12, Article 102-3 PROPOSALS AND PLAN HOLDER LISTS, lines 45-49, delete and replace with the following:

102-3 PROPOSALS AND INTERESTED PARTIES LIST

On Department projects advertised, the prospective bidder shall sign up on the *Interested Parties List* no later than one business day prior to the Letting day of that project, for which he intends to submit a bid. There is no cost for signing up on the *Interested Parties List* that can be found on the Department's website at connect.ncdot.gov/letting.

Page 1-12, Article 102-3 PROPOSALS AND PLAN HOLDER LISTS, lines 1-3, delete and replace the first sentence of the second paragraph with the following:

The proposal will state the location of the contemplated construction and show a schedule of contract items with the approximate quantity of each of these items for which bid prices are invited.

Page 1-14, Article 102-8 PREPARATION AND SUBMISSION OF BIDS, lines 30-31, delete and replace the first paragraph with the following:

Prior to submitting a bid on a project, the bidder shall sign up on the *Interested Parties List* in conformance with Article 102-3. The bidder shall submit a unit or lump sum price for every item in the proposal other than items that are authorized alternates to those items for which a bid price has been submitted.

LIABILITY INSURANCE:

(5-16-23)

107

SP1 G05

Revise the *2018 Standard Specifications* as follows:

Page 1-64, Article 107-15 LIABILITY INSURANCE, replace the first sentence with the following:

The Contractor shall at its sole cost and expense obtain and furnish to the Department an original standard Association for Cooperative Operations Research and Development (ACORD) certificate of liability insurance evidencing commercial general liability with a limit for bodily injury and property damage in the amount of \$5,000,000 per occurrence and \$5,000,000 general aggregate, covering the Contractor from claims or damages for bodily injury, personal injury, or for property damages that may arise from operating under the contract by the employees and agents of the Contractor.

CONTRACT TIME AND LIQUIDATED DAMAGES:

(4-17-12)(Rev. 5-16-23)

108

SP1 G08 C

The date of availability for this contract is **July 31, 2023**.

The completion date for this contract is **March 14, 2027**.

Except where otherwise provided by the contract, observation periods required by the contract will not be a part of the work to be completed by the completion date and/or intermediate contract times stated in the contract. The acceptable completion of the observation periods that extend beyond the final completion date shall be a part of the work covered by the performance and payment bonds.

The liquidated damages for this contract are **Two Hundred Dollars (\$ 200.00)** per calendar day. These liquidated damages will not be cumulative with any liquidated damages which may become chargeable under Intermediate Contract Time Number 1.

INTERMEDIATE CONTRACT TIME NUMBER 1 AND LIQUIDATED DAMAGES:

(7-1-95) (Rev. 2-21-12)

108

SP1 G13 A

Except for that work required under the Project Special Provisions entitled *Planting, Reforestation* and/or *Permanent Vegetation Establishment*, included elsewhere in this proposal, the Contractor will be required to complete all work included in this contract and shall place and maintain traffic on same.

The date of availability for this intermediate contract time is **July 31, 2023**.

The completion date for this intermediate contract time is **September 15, 2026**.

The liquidated damages for this intermediate contract time are **Two Thousand Dollars (\$ 2,000.00)** per calendar day.

Upon apparent completion of all the work required to be completed by this intermediate date, a final inspection will be held in accordance with Article 105-17 and upon acceptance, the Department will assume responsibility for the maintenance of all work except *Planting, Reforestation* and/or *Permanent Vegetation Establishment*. The Contractor will be responsible for and shall make corrections of all damages to the completed roadway caused by his planting operations, whether occurring prior to or after placing traffic through the project.

INTERMEDIATE CONTRACT TIME NUMBER 2 AND LIQUIDATED DAMAGES:

(2-20-07)

108

SP1 G14 A

The Contractor shall complete the required work of installing, maintaining, and removing the traffic control devices for lane closures and restoring traffic to the existing traffic pattern. The Contractor shall not close or narrow a lane of traffic on **US 52** during the following time restrictions:

DAY AND TIME RESTRICTIONS

Monday thru Sunday, 6:00 A.M. to 8:00 P.M.

In addition, the Contractor shall not close or narrow a lane of traffic on **US 52**, detain and/or alter the traffic flow on or during holidays, holiday weekends, special events, or any other time when traffic is unusually heavy, including the following schedules:

HOLIDAY AND HOLIDAY WEEKEND LANE CLOSURE RESTRICTIONS

1. For **unexpected occurrence** that creates unusually high traffic volumes, as directed by the Engineer.
2. For **New Year's Day**, between the hours of **6:00 A.M.** December 31st and **8:00 P.M.** January 2nd. If New Year's Day is on a Friday, Saturday, Sunday or Monday, then until **8:00 P.M.** the following Tuesday.

3. For **Easter**, between the hours of **6:00 A.M.** Thursday and **8:00 P.M.** Monday.
4. For **Memorial Day**, between the hours of **6:00 A.M.** Friday and **8:00 P.M.** Tuesday.
5. For **Independence Day**, between the hours of **6:00 A.M.** the day before Independence Day and **8:00 P.M.** the day after Independence Day.

If **Independence Day** is on a Friday, Saturday, Sunday or Monday, then between the hours of **6:00 A.M.** the Thursday before Independence Day and **8:00 P.M.** the Tuesday after Independence Day.
6. For **Labor Day**, between the hours of **6:00 A.M.** Friday and **8:00 P.M.** Tuesday.
7. For **Thanksgiving**, between the hours of **6:00 A.M.** Tuesday and **8:00 P.M.** Monday.
8. For **Christmas**, between the hours of **6:00 A.M.** the Friday before the week of Christmas Day and **8:00 P.M.** the following Tuesday after the week of Christmas Day.
9. For **Carolina Classic Fair**, between the hours of **6:00 A.M.** the day before the start of the **Carolina Classic Fair** and **8:00 P.M.** the following day after the end of the **Carolina Classic Fair**.
10. For **any Wake Forest University Event**, occurring at **Truist Field at Wake Forest University**, between **four (4)** hours before the start and **four (4)** hours after the end of **each event**.

Holidays and holiday weekends shall include New Year's, Easter, Memorial Day, Independence Day, Labor Day, Thanksgiving, and Christmas. The Contractor shall schedule his work so that lane closures will not be required during these periods, unless otherwise directed by the Engineer.

The time of availability for this intermediate contract work shall be the time the Contractor begins to install all traffic control devices for lane closures according to the time restrictions listed herein.

The completion time for this intermediate contract work shall be the time the Contractor is required to complete the removal of all traffic control devices for lane closures according to the time restrictions stated above and place traffic in the existing traffic pattern.

The liquidated damages are **One Thousand Two Hundred Fifty Dollars (\$ 1,250.00)** per fifteen **(15)** minute time period.

INTERMEDIATE CONTRACT TIME NUMBER 3 AND LIQUIDATED DAMAGES:

(2-20-07)

108

SP1 G14 A

The Contractor shall complete the required work of installing, maintaining, and removing the traffic control devices for lane closures and restoring traffic to the existing traffic pattern. The Contractor shall not close or narrow a lane of traffic on **the following roads** during the following time restrictions:

DAY AND TIME RESTRICTIONS**Hanes Mill Road (from Beginning of Project to University Parkway)****Monday thru Sunday, 6:00 A.M. to 8:00 P.M.****Hanes Mill Road (from University Parkway to End of Project)
and/or University Parkway****Monday thru Sunday, 6:00 A.M. to 9:00 A.M and 4:00 P.M. to 7:00 P.M**

In addition, the Contractor shall not close or narrow a lane of traffic on **Any Road other than US 52**, detain and/or alter the traffic flow on or during holidays, holiday weekends, special events, or any other time when traffic is unusually heavy, including the following schedules:

HOLIDAY AND HOLIDAY WEEKEND LANE CLOSURE RESTRICTIONS

1. For **unexpected occurrence** that creates unusually high traffic volumes, as directed by the Engineer.
2. For **New Year's Day**, between the hours of **6:00 A.M.** December 31st and **8:00 P.M.** January 2nd. If New Year's Day is on a Friday, Saturday, Sunday or Monday, then until **8:00 P.M.** the following Tuesday.
3. For **Easter**, between the hours of **6:00 A.M.** Thursday and **8:00 P.M.** Monday.
4. For **Memorial Day**, between the hours of **6:00 A.M.** Friday and **8:00 P.M.** Tuesday.
5. For **Independence Day**, between the hours of **6:00 A.M.** the day before Independence Day and **8:00 P.M.** the day after Independence Day.

If **Independence Day** is on a Friday, Saturday, Sunday or Monday, then between the hours of **6:00 A.M.** the Thursday before Independence Day and **8:00 P.M.** the Tuesday after Independence Day.
6. For **Labor Day**, between the hours of **6:00 A.M.** Friday and **8:00 P.M.** Tuesday.
7. For **Thanksgiving**, between the hours of **6:00 A.M.** Tuesday and **8:00 P.M.** Monday.
8. For **Christmas**, between the hours of **6:00 A.M.** the Friday before the week of Christmas Day and **8:00 P.M.** the following Tuesday after the week of Christmas Day.

9. For **Carolina Classic Fair**, between the hours of **6:00 A.M.** the day before the start of the **Carolina Classic Fair** and **8:00 P.M.** the following day after the end of the **Carolina Classic Fair**.
10. For **any Wake Forest University Event**, occurring at **Truist Field at Wake Forest University**, between **four (4)** hours before the start and **four (4)** hours after the end of **each event**.

Holidays and holiday weekends shall include New Year's, Easter, Memorial Day, Independence Day, Labor Day, Thanksgiving, and Christmas. The Contractor shall schedule his work so that lane closures will not be required during these periods, unless otherwise directed by the Engineer.

The time of availability for this intermediate contract work shall be the time the Contractor begins to install all traffic control devices for lane closures according to the time restrictions listed herein.

The completion time for this intermediate contract work shall be the time the Contractor is required to complete the removal of all traffic control devices for lane closures according to the time restrictions stated above and place traffic in the existing traffic pattern.

The liquidated damages are **Two Hundred Fifty Dollars (\$ 250.00)** per hour.

INTERMEDIATE CONTRACT TIME NUMBER 4 AND LIQUIDATED DAMAGES:

(2-20-07) (Rev. 10-15-13)

108

SP1 G14 E

The Contractor shall complete the required work of installing, maintaining and removing the traffic control devices for road closures and restoring traffic to the existing traffic pattern. The Contractor shall not close **US 52** during the following time restrictions:

DAY AND TIME RESTRICTIONS

Monday thru Sunday, 6:00 A.M. to 12:00 A.M. (Midnight)

The maximum allowable time for **hanging proposed girders and/or removing existing overhead structure** is **thirty (30)** minutes for **US 52**. The Contractor shall reopen the travel lanes to traffic until any resulting traffic queue is depleted.

The time of availability for this intermediate contract time will be the time the Contractor begins to install traffic control devices required for the road closures according to the time restrictions stated herein.

The completion time for this intermediate contract time will be the time the Contractor is required to complete the removal of traffic control devices required for the road closures according to the time restrictions stated herein and restore traffic to the existing traffic pattern.

The liquidated damages are **Two Thousand Five Hundred Dollars (\$ 2,500.00)** per fifteen **(15)** minute time period.

INTERMEDIATE CONTRACT TIME NUMBER 5 AND LIQUIDATED DAMAGES:

(2-20-07) (Rev. 6-18-13)

108

SP1 G14 H

The Contractor shall complete the work required of **Phase IV, Steps #4 thru #6** as shown on Sheet **TMP-3B** and shall place and maintain traffic on same.

The date of availability for this intermediate contract time is the date the Contractor elects to begin the work.

The completion date for this intermediate contract time is the date which is **thirty (30)** consecutive calendar days after and including the date the Contractor begins this work.

The liquidated damages are **One Thousand Five Hundred Dollars (\$ 1,500.00)** per calendar day.

INTERMEDIATE CONTRACT TIME NUMBER 6 AND LIQUIDATED DAMAGES:

(2-20-07) (Rev. 6-18-13)

108

SP1 G14 H

The Contractor shall complete the work required of **Phase IV, Steps #9 thru #11** as shown on Sheet **TMP-3B** and shall place and maintain traffic on same.

The date of availability for this intermediate contract time is the date the Contractor elects to begin the work.

The completion date for this intermediate contract time is the date which is **thirty (30)** consecutive calendar days after and including the date the Contractor begins this work.

The liquidated damages are **Two Thousand Five Hundred Dollars (\$ 2,500.00)** per calendar day.

INTERMEDIATE CONTRACT TIME NUMBER 7 AND LIQUIDATED DAMAGES FOR FAILURE TO REPAIR A DAMAGED FIBER OPTIC COMMUNICATIONS CABLE AND RESTORE COMMUNICATION

The Contractor shall repair all existing fiber optic communication cables damaged during construction. The Contractor shall immediately report damages to the Engineer and the affected owner of the fiber optic communications cable listed above. The Contractor shall repair all damage within forty-eight (48) hours at no cost to the Department. The Contractor shall bring all affected fiber optic communication cables back online within the same forty-eight (48) hours. A “damaged” fiber optic communications cable is any fiber communications cable that is damaged due to an accidental or unscheduled outage event.

Liquidated Damages for failure to repair a damaged fiber optic communications cable and restore communication within forty-eight (48) hours are Five Hundred Dollars (\$ 500.00) per hour, or any portion thereof.

INTERMEDIATE CONTRACT TIME NUMBERS 8 AND 9 FOR FAILURE TO REESTABLISH ITS FIBER COMMUNICATIONS

During construction, the Contractor shall coordinate any disruption in any fiber optic communications with the Engineer and the affected owner of the fiber optic cable a minimum of twenty-one (21) calendar days prior to all proposed disruptions in service. A minimum of twenty-

one (21) calendar days prior to any disruption in the fiber optic communications, the Contractor shall develop and provide a plan to the affected owner of the fiber optic communications cable for approval that defines 1) an anticipated disruption timeframe and 2) a plan of action for reestablishing communications within forty-eight (48) hours. Upon approval of an acceptable plan with the affected owner of the fiber optics communications cable the Contractor shall submit the approved plan(s) to the Engineer and coordinate the beginning of the planned work.

Liquidated Damages for failure to reestablish ITS fiber optic communications within forty-eight (48) hours are Two Thousand Five Hundred Dollars (\$ 2,500.00) per day, or any portion thereof.

Liquidated Damages for failure to provide a plan that defines 1) an anticipated fiber optic communications disruption timeframe and 2) a plan of action for reestablishing communications a minimum of twenty-one (21) calendar days prior to a proposed disruption in service are Ten Thousand Dollars (\$ 10,000.00) per failure.

PERMANENT VEGETATION ESTABLISHMENT:

(2-16-12) (Rev. 10-15-13)

104

SP1 G16

Establish a permanent stand of the vegetation mixture shown in the contract. During the period between initial vegetation planting and final project acceptance, perform all work necessary to establish permanent vegetation on all erodible areas within the project limits, as well as, in borrow and waste pits. This work shall include erosion control device maintenance and installation, repair seeding and mulching, supplemental seeding and mulching, mowing, and fertilizer topdressing, as directed. All work shall be performed in accordance with the applicable section of the *2018 Standard Specifications*. All work required for initial vegetation planting shall be performed as a part of the work necessary for the completion and acceptance of the Intermediate Contract Time (ICT). Between the time of ICT and Final Project acceptance, or otherwise referred to as the vegetation establishment period, the Department will be responsible for preparing the required National Pollutant Discharge Elimination System (NPDES) inspection records.

Once the Engineer has determined that the permanent vegetation establishment requirement has been achieved at an 80% vegetation density (the amount of established vegetation per given area to stabilize the soil) and no erodible areas exist within the project limits, the Contractor will be notified to remove the remaining erosion control devices that are no longer needed. The Contractor will be responsible for, and shall correct any areas disturbed by operations performed in permanent vegetation establishment and the removal of temporary erosion control measures, whether occurring prior to or after placing traffic on the project.

Payment for *Response for Erosion Control, Seeding and Mulching, Repair Seeding, Supplemental Seeding, Mowing, Fertilizer Topdressing, Silt Excavation, and Stone for Erosion Control* will be made at contract unit prices for the affected items. Work required that is not represented by contract line items will be paid in accordance with Articles 104-7 or 104-3 of the *2018 Standard Specifications*. No additional compensation will be made for maintenance and removal of temporary erosion control items.

DELAY IN RIGHT OF ENTRY:

(7-1-95) (Rev. 7-15-14)

108

SP1 G22

The Contractor will not be allowed right of entry to the following parcel(s) prior to the listed date(s) unless otherwise permitted by the Engineer.

<u>Parcel No.</u>	<u>Property Owner</u>	<u>Date</u>
003	Forsyth County	12-31-2023
004	Forsyth County	12-31-2023

MAJOR CONTRACT ITEMS:

(2-19-02)

104

SP1 G28

The following listed items are the major contract items for this contract (see Article 104-5 of the *2018 Standard Specifications*):

Line #	Description
36	Asphalt Concrete Base Course, Type B25.0C
37	Asphalt Concrete Intermediate Course, Type I19.0C
284	Reinforced Concrete Deck Slab

SPECIALTY ITEMS:

(7-1-95)(Rev. 7-20-21)

108-6

SP1 G37

Items listed below will be the specialty items for this contract (see Article 108-6 of the *2018 Standard Specifications*).

Line #	Description
77-86	Guardrail
87-89	Fencing
92-108	Signing
133-140, 142	Long-Life Pavement Markings
141, 143	Removable Tape
157-158	Permanent Pavement Markers
160-183	Utility Construction
184-215	Erosion Control
216-275	Signals/ITS System

FUEL PRICE ADJUSTMENT:

(11-15-05) (Rev. 11-15-22)

109-8

SP1 G43

Revise the *2018 Standard Specifications* as follows:

Page 1-87, Article 109-8, Fuel Price Adjustments, add the following:

The base index price for DIESEL #2 FUEL is \$ **2.6511** per gallon. Where any of the following are included as pay items in the contract, they will be eligible for fuel price adjustment.

The pay items and the fuel factor used in calculating adjustments to be made will be as follows:

Description	Units	Fuel Usage Factor Diesel
Unclassified Excavation	Gal/CY	0.29
Borrow Excavation	Gal/CY	0.29
Class IV Subgrade Stabilization	Gal/Ton	0.55
Aggregate Base Course	Gal/Ton	0.55
Sub-Ballast	Gal/Ton	0.55
Erosion Control Stone	Gal/Ton	0.55
Rip Rap, Class _____	Gal/Ton	0.55
Asphalt Concrete Base Course, Type _____	Gal/Ton	0.90 or 2.90
Asphalt Concrete Intermediate Course, Type _____	Gal/Ton	0.90 or 2.90
Asphalt Concrete Surface Course, Type _____	Gal/Ton	0.90 or 2.90
Open-Graded Asphalt Friction Course	Gal/Ton	0.90 or 2.90
Permeable Asphalt Drainage Course, Type _____	Gal/Ton	0.90 or 2.90
Sand Asphalt Surface Course, Type _____	Gal/Ton	0.90 or 2.90
Ultra-thin Bonded Wearing Course	Gal/Ton	0.90 or 2.90
Aggregate for Cement Treated Base Course	Gal/Ton	0.55
Portland Cement for Cement Treated Base Course	Gal/Ton	0.55
> 11" Portland Cement Concrete Pavement	Gal/SY	0.327
Concrete Shoulders Adjacent to > 11" Pavement	Gal/SY	0.327
9" to 11" Portland Cement Concrete Pavement	Gal/SY	0.272
Concrete Shoulders Adjacent to 9" to 11" Pavement	Gal/SY	0.272
< 9" Portland Cement Concrete Pavement	Gal/SY	0.245
Concrete Shoulders Adjacent to < 9" Pavement	Gal/SY	0.245

For the asphalt items noted in the chart as eligible for fuel adjustments, the bidder may include the *Fuel Usage Factor Adjustment Form* with their bid submission if they elect to use the fuel usage factor. The *Fuel Usage Factor Adjustment Form* is found at the following link:

<https://connect.ncdot.gov/letting/LetCentral/Fuel%20Usage%20Factor%20Adjustment%20Form%20-%20Starting%20Nov%202022%20Lettings.pdf>

Select either 2.90 Gal/Ton fuel factor or 0.90 Gal/Ton fuel factor for each asphalt line item on the *Fuel Usage Factor Adjustment Form*. The selected fuel factor for each asphalt item will remain in effect for the duration of the contract.

Failure to complete the *Fuel Usage Factor Adjustment Form* will result in using 2.90 gallons per ton as the Fuel Usage Factor for Diesel for the asphalt items noted above. The contractor will not be permitted to change the Fuel Usage Factor after the bids are submitted.

STEEL PRICE ADJUSTMENT:

(4-19-22)(Rev. 6-20-23)

SP1 G47

Description and Purpose

Steel price adjustments will be made to the payments due the Contractor for items as defined herein that are permanently incorporated into the work, when the price of raw steel mill products utilized on the contract have fluctuated. The Department will adjust monthly progress payments up or down as appropriate for cost changes in steel according to this provision.

Eligible Items

The list of eligible bid items for steel price adjustment can be found on the Departments website at the following address:

<https://connect.ncdot.gov/letting/LetCentral/Eligible%20Bid%20Items%20for%20Steel%20Price%20Adjustment.xlsx>

Nuts, bolts, anchor bolts, rebar chairs, connecting bands and other miscellaneous hardware associated with these items shall not be included in the price adjustment.

Adjustments will only be made for fluctuations in the material cost of the steel used in the above products as specified in the Product Relationship Table below. The producing mill is defined as the source of steel product before any fabrication has occurred (e.g., coil, plate, rebar, hot rolled shapes, etc.). No adjustment will be made for changes in the cost of fabrication, coating, shipping, storage, etc.

No steel price adjustments will be made for any products manufactured from steel having an adjustment date, as defined by the Product Relationship Table below, prior to the letting date.

Bid Submittal Requirements

The successful bidder, within 14 calendar days after the notice of award is received by him, shall provide the completed Form SPA-1 to the Department (State Contract Officer or Division Contract Engineer) along with the payment bonds, performance bonds and contract execution signature sheets in a single submittal. If Form SPA-1 is not included in the same submittal as the payment bonds, performance bonds and contract execution signature sheets, the Contractor will not be eligible for any steel price adjustment for any item in the contract for the life of the contract. Form SPA-1 can be found on the Department's website at the following address:

<https://connect.ncdot.gov/letting/LetCentral/Form%20SPA-1.xlsm>

The Contractor shall provide Form SPA-1 listing the Contract Line Number, (with corresponding Item Number, Item Description, and Category) for the steel products they wish to have an adjustment calculated. Only the contract items corresponding to the list of eligible item numbers for steel price adjustment may be entered on Form SPA-1. The Contractor may choose to have steel price adjustment applied to any, all, or none of the eligible items. However, the

Contractor's selection of items for steel price adjustment or non-selection (non-participation) may not be changed once Form SPA-1 has been received by the Department. Items the Bidder chooses for steel price adjustment must be designated by writing the word "Yes" in the column titled "Option" by each Pay Item chosen for adjustment. Should the bidder elect an eligible steel price item, the entire quantity of the line item will be subject to the price adjustment for the duration of the Contract. The Bidder's designations on Form SPA-1 must be written in ink or typed and signed by the Bidder (Prime Contractor) to be considered complete. Items not properly designated, designated with "No", or left blank on the Bidder's Form SPA-1 will automatically be removed from consideration for adjustment. No steel items will be eligible for steel price adjustment on this Project if the Bidder fails to return Form SPA-1 in accordance with this provision.

Establishing the Base Price

The Department will use a blend of monthly average prices as reported from the Fastmarkets platform to calculate the monthly adjustment indices (BI and MI). This data is typically available on the first day of the month for the preceding month. The indices will be calculated by the Department for the different categories found on the Product Relationship Table below. For item numbers that include multiple types of steel products, the category listed for that item number will be used for adjusting each steel component.

The bidding index for Category 1 Steel items is **\$ 48.25** per hundredweight.

The bidding index for Category 2 Steel items is **\$ 74.26** per hundredweight.

The bidding index for Category 3 Steel items is **\$ 66.48** per hundredweight.

The bidding index for Category 4 Steel items is **\$ 58.60** per hundredweight.

The bidding index for Category 5 Steel items is **\$ 59.19** per hundredweight.

The bidding index for Category 6 Steel items is **\$ 78.86** per hundredweight.

The bidding index for Category 7 Steel items is **\$ 51.93** per hundredweight.

The bidding index represents a selling price of steel based on Fastmarkets data for the month of **April 2023**.

MI = Monthly Index. – in Dollars (\$) per hundredweight (CWT). Use the adjustment indices from the month the steel was shipped from the producing mill, received on the project, or member cast as defined in the Product Relationship Table.

BI = Bidding Index. - in Dollars (\$) per hundredweight (CWT). Use the adjustment indices as listed in the proposal.

<i>Steel Product (Title)</i>	BI, MI*	Adjustment Date for MI	Category
Reinforcing Steel, Bridge Deck, and SIP Forms	Based on one or more Fastmarkets indices	Delivery Date from Producing Mill	1
Structural Steel and Encasement Pipe	Based on one or more Fastmarkets indices	Delivery Date from Producing Mill	2
Steel H-Piles, Soldier Pile Walls	Based on one or more Fastmarkets indices	Delivery Date from Producing Mill	3
Guardrail Items and Pipe Piles	Based on one or more Fastmarkets indices	Material Received Date**	4

Fence Items	Based on one or more Fastmarkets indices	Material Received Date**	5
Overhead Sign Assembly, Signal Poles, High Mount Standards	Based on one or more Fastmarkets indices	Material Received Date**	6
Prestressed Concrete Members	Based on one or more Fastmarkets indices	Cast Date of Member	7

Submit documentation to the Engineer for all items listed in the Contract for which the Contractor is requesting a steel price adjustment.

Submittal Requirements

The items in categories 1,2, and 3, shall be specifically stored, labeled, or tagged, recognizable by color marking, and identifiable by Project for inspection and audit verification immediately upon arrival at the fabricator.

Furnish the following documentation for all steel products to be incorporated into the work and documented on Form SPA-2, found on the Departments website at the following address:

<https://connect.ncdot.gov/projects/construction/Construction%20Forms/Form%20SPA-2.xlsx>

Submit all documentation to the Engineer prior to incorporation of the steel into the completed work. The Department will withhold progress payments for the affected contract line item if the documentation is not provided and at the discretion of the Engineer the work is allowed to proceed. Progress payments will be made upon receipt of the delinquent documentation.

Step 1 (Form SPA -2)

Utilizing Form SPA-2, submit separate documentation packages for each line item from Form SPA-1 for which the Contractor opted for a steel price adjustment. For line items with multiple components of steel, each component should be listed separately. Label each SPA-2 documentation package with a unique number as described below.

- a. Documentation package number: (Insert the contract line-item) - (Insert sequential package number beginning with "1").
Example: 412 - 1,
412 - 2,
424 - 1,
424 - 2,
424 - 3, etc.
- b. The steel product quantity in pounds
 - i. The following sources should be used, in declining order of precedence, to determine the weight of steel/iron, based on the Engineers decision:
 1. Department established weights of steel/iron by contract pay item per pay unit;
 2. Approved Shop Drawings;
 3. Verified Shipping Documents;

4. Contract Plans;
 5. Standard Drawing Sheets;
 6. Industry Standards (i.e., AISC Manual of Steel Construction, AWWA Standards, etc.); and
 7. Manufacture's data.
- ii. Any item requiring approved shop drawings shall have the weights of steel calculated and shown on the shop drawings or submitted and certified separately by the fabricator.
- c. The date the steel product, subject to adjustment, was shipped from the producing mill (Categories 1-3), received on the project (Categories 4-6), or casting date (Category 7).

Step 2 (Monthly Calculator Spreadsheet)

For each month, upon the incorporation of the steel product into the work, provide the Engineer the following:

- 1) Completed NCDOT Steel Price Adjustment Calculator Spreadsheet, summarizing all the steel submittal packages (Form SPA-2) actually incorporated into the completed work in the given month.
 - a. Contract Number
 - b. Bidding Index Reference Month
 - c. Contract Completion Date or Revised Completion Date
 - d. County, Route, and Project TIP information
 - e. Item Number
 - f. Line-Item Description
 - g. Submittal Number from Form SPA-2
 - h. Adjustment date
 - i. Pounds of Steel
- 2) An affidavit signed by the Contractor stating the documentation provided in the NCDOT Steel Price Adjustment Calculator Spreadsheet is true and accurate.

Price Adjustment Conditions

Download the Monthly Steel Adjustment Spreadsheet with the most current reference data from the Department's website each month at the following address:

<https://connect.ncdot.gov/projects/construction/Construction%20Forms/Form%20SPA-3%20NCDOT%20Steel%20Price%20Adjustment%20Calculator.xlsx>

If the monthly Fastmarkets data is not available, the data for the most recent immediately preceding month will be used as the basis for adjustment.

Price Adjustment Calculations

The price adjustment will be determined by comparing the percentage of change in index value listed in the proposal (BI) to the monthly index value (MI). (See included sample examples). Weights and date of shipment must be documented as required herein. The final price adjustment dollar value will be determined by multiplying this percentage increase or decrease in

the index by the represented quantity of steel incorporated into the work, and the established bidding index (BI) subject to the limitations herein.

Price increase/decrease will be computed as follows:

$$\text{SPA} = ((\text{MI} / \text{BI}) - 1) * \text{BI} * (\text{Q} / 100)$$

Where;

SPA = Steel price adjustment in dollars

MI = Monthly Shipping Index. – in Dollars (\$) per hundredweight (CWT). Use the adjustment indices from the month the steel was shipped from the producing mill, received on the project, or member cast as defined in the Product Relationship Table.

BI = Bidding Index. - in Dollars (\$) per hundredweight (CWT). Use the adjustment indices as listed in the proposal.

Q = Quantity of steel, product, pounds actually incorporated into the work as documented by the Contractor, or Design Build Team and verified by the Engineer.

Calculations for price adjustment shall be shown separate from the monthly progress estimate and will not be included in the total cost of work for determination of progress or for extension of Contract time in accordance with Subarticle 108-10(B)(1).

Any apparent attempt to unbalance bids in favor of items subject to price adjustment may result in rejection of the bid proposal.

Adjustments will be paid or charged to the Contractor only. Any Contractor receiving an adjustment under this provision shall distribute the proper proportional part of such adjustments to the subcontractor who performed the applicable work.

Delays to the work caused by steel shortages may be justification for a Contract time extension but will not constitute grounds for claims for standby equipment, extended office overhead, or other costs associated with such delays.

If an increase in the steel material price is anticipated to exceed 50% of the original quoted price, the contractor must notify the Department within 7 days prior to purchasing the material. Upon receipt of such notification, the Department will direct the Contractor to either (1) proceed with the work or (2) suspend the work and explore the use of alternate options.

If the decrease in the steel material exceeds 50% of the original quoted price, the contractor may submit to the Department additional market index information specific to the item in question to dispute the decrease. The Department will review this information and determine if the decrease is warranted.

When the steel product adjustment date, as defined in the Product Relationship Table, is after the approved contract completion date, the steel price adjustments will be based on the lesser value of either the MI for the month of the approved contract completion date or the MI for the actual adjustment date.

If the price adjustment is based on estimated material quantities for that time, and a revision to the total material quantity is made in a subsequent or final estimate, an appropriate adjustment will be made to the price adjustment previously calculated. The adjustment will be based on the same indices used to calculate the price adjustment which is being revised. If the adjustment date of the revised material quantity cannot be determined, the adjustment for the quantity in question, will be based on the indices utilized to calculate the steel price adjustment for the last initial documentation package submission, for the steel product subject to adjustment, that was incorporated into the particular item of work, for which quantities are being finalized.

Example: Structural steel for a particular bridge was provided for in three different shipments with each having a different mill shipping date. The quantity of structural steel actually used for the bridge was calculated and a steel price adjustment was made in a progress payment. At the conclusion of the work an error was found in the plans of the final quantity of structural steel used for the bridge. The quantity to be adjusted cannot be directly related to any one of the three mill shipping dates. The steel price adjustment for the quantity in question would be calculated using the indices that were utilized to calculate the steel price adjustment for the quantity of structural steel represented by the last initial structural steel documentation package submission. The package used will be the one with the greatest sequential number.

Extra Work/Force Account:

When steel products, as specified herein, are added to the contract as extra work, in accordance with the provisions of Article 104-7 or 104-3, the Engineer will determine and specify in the supplemental agreement, the need for application of steel price adjustments on a case-by-case basis. No steel price adjustments will be made for any products manufactured from steel having an adjustment date prior to the supplemental agreement execution date. Price adjustments will be made as provided herein, except the Bidding Index will be based on the month in which the supplemental agreement pricing was executed.

For work performed on force account basis, reimbursement of actual material costs, along with the specified overhead and profit markup, will be considered to include full compensation for the current cost of steel and no steel price adjustments will be made.

Examples Form SPA-2 Steel Price Adjustment Submission Form

Contract Number C203394 Bid Reference Month January 2019
 Submittal Date 8/31/2019
 Contract Line Item 237
 Line Item Description APPROX....LBS Structural Steel
 Sequential Submittal Number 2

Supplier	Description of material	Location information	Quantity in lbs.	Adjustment Date
XYZ mill	Structural Steel	Structure 3, Spans A-C	1,200,000	May 4, 2020

ABC distributing	Various channel & angle shapes	Structure 3 Spans A-C	35,000	July 14, 2020
		Total Pounds of Steel	1,235,000	

Note: Attach the following supporting documentation to this form.

- Bill of Lading to support the shipping dates
- Supporting information for weight documentation (e.g., Pay item reference, Shop drawings, shipping documents, Standards Sheets, industry standards, or manufacturer's data)

By providing this data under my signature, I attest to the accuracy of and validity of the data on this form and certify that no deliberate misrepresentation in any manner has occurred.

Printed Name

Signature

**Examples Form SPA-2
Steel Price Adjustment Submission Form**

Contract Number C203394 Bid Reference Month January 2019

Submittal Date August 31, 2019

Contract Line Item 237

Line Item Description SUPPORT, OVRHD SIGN STR -DFEB – STA 36+00

Sequential Submittal Number 2

Supplier	Description of material	Location information	Quantity in lbs.	Adjustment Date
XYZ mill	Tubular Steel (Vertical legs)	-DFEB – STA 36+00	12000	December 11, 2021
PDQ Mill	4” Tubular steel (Horizontal legs)	-DFEB – STA 36+00	5900	December 11, 2021
ABC distributing	Various channel & angle shapes (see quote)	-DFEB – STA 36+00	1300	December 11, 2021
	Catwalk assembly	-DFEB – STA 36+00	2000	December 11, 2021
Nucor	Flat plate	-DFEB – STA 36+00	650	December 11, 2021
		Total Pounds of Steel	21,850	

Note: Attach the following supporting documentation to this form.

- Bill of Lading to support the shipping dates

- Supporting information for weight documentation (e.g., Pay item reference, Shop drawings, shipping documents, Standards Sheets, industry standards, or manufacturer's data)

By providing this data under my signature, I attest to the accuracy of and validity of the data on this form and certify that no deliberate misrepresentation in any manner has occurred.

Printed Name

Signature

Price Adjustment Sample Calculation (increase)

Project bid on September 17, 2019

Line Item 635 "Structural Steel" has a plan quantity of 2,717,000 lbs.

Bidding Index for Structural Steel (Category 2) in the proposal was \$36.12/CWT = BI

450,000 lbs. of Structural Steel for Structure 2 at Station 44+08.60 were shipped to fabricator from the producing mill in same month, May 2021.

Monthly Index for Structural Steel (Category 2) for May 2021 was \$64.89/CWT = MI

The Steel Price Adjustment formula is as follows:

$$\text{SPA} = ((\text{MI} / \text{BI}) - 1) * \text{BI} * (\text{Q} / 100)$$

Where; SPA = Steel price adjustment in dollars

BI = Bidding Index – in dollars (\$) per hundredweight (CWT). Use the adjustment indices as listed in the proposal.

MI = Mill Shipping Index – in dollars (\$) per hundredweight (CWT). Use the adjustment indices from the month the steel was shipped from the producing mill, received on the project, or member cast as defined in the Product Relationship Table.

Q = Quantity of steel product, in pounds (lbs.) actually incorporated into the work as documented by the Contractor, or Design Build Team and verified by the Engineer.

BI = \$36.12/ CWT

MI = \$64.89 / CWT

$$\% \text{ change} = ((\text{MI}/ \text{BI})-1) = (\$64.89 / \$36.12 - 1) = (1.79651 - 1) = 0.79651162791$$

$$Q = 450,000 \text{ lbs.}$$

$$\text{SPA} = 0.79651162791 \times \$36.12 \times (450,000/100)$$

$$\text{SPA} = 0.79651162791 * \$36.12 * 4,500$$

$$\text{SPA} = \$129,465 \text{ pay adjustment to Contractor for Structural Steel (Structure 2 at Station 44+08.60)}$$

Price Adjustment Sample Calculation (decrease)

Project bid on December 18, 2018

Line Item 635 Structural Steel has a plan quantity of 2,717,000 lbs.

Bidding Index for Structural Steel (Category 2) in the proposal was \$46.72/CWT = BI

600,000 lbs. of Structural Steel for Structure 1 at Station 22+57.68 were shipped to fabricator from the producing mill in same month, August 2020.

Monthly Index for Structural Steel (Category 2) for August 2020 was \$27.03/CWT = MI

The Steel Price Adjustment formula is as follows:

$$\text{SPA} = ((\text{MI}/ \text{BI}) - 1) * \text{BI} * (\text{Q}/100)$$

Where; SPA = Steel price adjustment in dollars

BI = Bidding Index – in dollars (\$) per hundredweight (CWT). Use the adjustment indices as listed in the proposal.

MI = Mill Shipping Index – in dollars (\$) per hundredweight (CWT). Use the adjustment indices from the month the steel was shipped from the producing mill, received on the project, or member cast as defined in the Product Relationship Table.

Q = Quantity of steel product, in pounds (lbs.) actually incorporated into the work as documented by the Contractor, or Design Build Team and verified by the Engineer.

$$\text{BI} = \$46.72/ \text{CWT}$$

$$\text{MI} = \$27.03 / \text{CWT}$$

$$\% \text{ change} = ((\text{MI}/ \text{BI})-1) = (\$27.03/ \$46.72-1) = (0.57855-1) = -0.421446917808$$

Q = 600,000 lbs.

SPA = $-0.421446917808 * \$46.72 * (600,000/100)$

SPA = $-0.421446917808 * \$46.72 * 6,000$

SPA = \$ 118,140.00 Credit to the Department for Structural Steel (Structure 1 at Station 22+57.68)

Price Adjustment Sample Calculation (increase)

Project bid on July 16, 2020

Line Item 614 Reinforced Concrete Deck Slab has a plan quantity of 241974 lbs.

Bidding Index Reference Month was May 2020. Bidding Index for Reinforced Concrete Deck Slab (Category 1) in the proposal was \$29.21/CWT = BI

51,621 lbs. of reinforcing steel and 52,311 lbs. of epoxy coated reinforcing steel for Structure 2 at Station 107+45.55 -L- was shipped to fabricator from the producing mill in same month, May 2021.

Monthly Index for Reinforced Concrete Deck Slab (Category 1) for May 2021 was \$43.13/CWT = MI

The Steel Price Adjustment formula is as follows:

$$\text{SPA} = ((\text{MI} / \text{BI}) - 1) * \text{BI} * (\text{Q} / 100)$$

Where; SPA = Steel price adjustment in dollars

BI = Bidding Index – in dollars (\$) per hundredweight (CWT). Use the adjustment indices as listed in the proposal.

MI = Mill Shipping Index – in dollars (\$) per hundredweight (CWT). Use the adjustment indices from the month the steel was shipped from the producing mill, received on the project, or member cast as defined in the Product Relationship Table.

Q = Quantity of steel product, in pounds (lbs.) actually incorporated into the work as documented by the Contractor, or Design Build Team and verified by the Engineer.

BI = \$29.21/ CWT

MI = \$43.13 / CWT

% change = $((\text{MI} / \text{BI}) - 1) = (\$43.13 / \$29.21 - 1) = (1.47655 - 1) = 0.47654912701$

Q = 103932 lbs.

SPA = $0.47654912701 * \$29.21 * (103,932/100)$

SPA = $0.47654912701 * \$29.21 * 1,039.32$

SPA = \$14,467.33 Pay Adjustment to Contractor for Reinforced Concrete Deck Slab (Category 1) at Station 107+45.55 -L-

SCHEDULE OF ESTIMATED COMPLETION PROGRESS:

(7-15-08) (Rev. 6-20-23)

108-2

SP1 G58

The Contractor's attention is directed to the Standard Special Provision entitled *Availability of Funds Termination of Contracts* included elsewhere in this proposal. The Department of Transportation's schedule of estimated completion progress for this project as required by that Standard Special Provision is as follows:

	<u>Fiscal Year</u>	<u>Progress (% of Dollar Value)</u>
2024	(7/01/23 - 6/30/24)	37% of Total Amount Bid
2025	(7/01/24 - 6/30/25)	35% of Total Amount Bid
2026	(7/01/25 - 6/30/26)	25% of Total Amount Bid
2027	(7/01/26 - 6/30/27)	3% of Total Amount Bid

The Contractor shall also furnish his own progress schedule in accordance with Article 108-2 of the *2018 Standard Specifications*. Any acceleration of the progress as shown by the Contractor's progress schedule over the progress as shown above shall be subject to the approval of the Engineer.

MINORITY BUSINESS ENTERPRISE AND WOMEN BUSINESS ENTERPRISE:

(10-16-07)(Rev. 8-17-21)

102-15(J)

SP1 G66

Description

The purpose of this Special Provision is to carry out the North Carolina Department of Transportation's policy of ensuring nondiscrimination in the award and administration of contracts financed in whole or in part with State funds.

Definitions

Additional MBE/WBE Subcontractors - Any MBE/WBE submitted at the time of bid that will not be used to meet the Combined MBE /WBE Goal. No submittal of a Letter of Intent is required.

Combined MBE/WBE Goal: A portion of the total contract, expressed as a percentage that is to be performed by committed MBE/WBE subcontractors.

Committed MBE/WBE Subcontractor - Any MBE/WBE submitted at the time of bid that is being used to meet the Combined MBE /WBE goal by submission of a Letter of Intent. Or any MBE or WBE used as a replacement for a previously committed MBE or WBE firm.

Contract Goal Requirement - The approved participation at time of award, but not greater than the advertised Combined MBE/WBE contract goal.

Goal Confirmation Letter - Written documentation from the Department to the bidder confirming the Contractor's approved, committed participation along with a listing of the committed MBE and WBE firms.

Manufacturer - A firm that operates or maintains a factory or establishment that produces on the premises, the materials or supplies obtained by the Contractor.

MBE Participation (Anticipated) - A portion of the total contract, expressed as a percentage that is anticipated to be performed by committed MBE subcontractor(s).

Minority Business Enterprise (MBE) - A firm certified as a Disadvantaged Minority-Owned Business Enterprise through the North Carolina Unified Certification Program.

Regular Dealer - A firm that owns, operates, or maintains a store, warehouse, or other establishment in which the materials or supplies required for the performance of the contract are bought, kept in stock, and regularly sold to the public in the usual course of business. A regular dealer engages in, as its principal business and in its own name, the purchase and sale or lease of the products in question. A regular dealer in such bulk items as steel, cement, gravel, stone, and petroleum products need not keep such products in stock, if it owns and operates distribution equipment for the products. Brokers and packagers are not regarded as manufacturers or regular dealers within the meaning of this section.

Replacement / Substitution – A full or partial reduction in the amount of work subcontracted to a committed (or an approved substitute) MBE/WBE firm.

North Carolina Unified Certification Program (NCUCP) - A program that provides comprehensive services and information to applicants for MBE/WBE certification. The MBE/WBE program follows the same regulations as the federal Disadvantaged Business Enterprise (DBE) program in accordance with 49 CFR Part 26.

United States Department of Transportation (USDOT) - Federal agency responsible for issuing regulations (49 CFR Part 26) and official guidance for the DBE program.

WBE Participation (Anticipated) - A portion of the total contract, expressed as a percentage, that is anticipated to be performed by committed WBE subcontractor(s).

Women Business Enterprise (WBE) - A firm certified as a Disadvantaged Women-Owned Business Enterprise through the North Carolina Unified Certification Program.

Forms and Websites Referenced in this Provision

Payment Tracking System - On-line system in which the Contractor enters the payments made to MBE and WBE subcontractors who have performed work on the project.
<https://apps.dot.state.nc.us/Vendor/PaymentTracking/>

DBE-IS Subcontractor Payment Information - Form for reporting the payments made to all MBE/WBE firms working on the project. This form is for paper bid projects only.
<https://connect.ncdot.gov/business/Turnpike/Documents/Form%20DBE-IS%20Subcontractor%20Payment%20Information.pdf>

RF-1 MBE/WBE Replacement Request Form - Form for replacing a committed MBE or WBE.
<http://connect.ncdot.gov/projects/construction/Construction%20Forms/DBE%20MBE%20WBE%20Replacement%20Request%20Form.pdf>

SAF Subcontract Approval Form - Form required for approval to sublet the contract.
<http://connect.ncdot.gov/projects/construction/Construction%20Forms/Subcontract%20Approval%20Form%20Rev.%202012.zip>

JC-1 Joint Check Notification Form - Form and procedures for joint check notification. The form acts as a written joint check agreement among the parties providing full and prompt disclosure of the expected use of joint checks.
<http://connect.ncdot.gov/projects/construction/Construction%20Forms/Joint%20Check%20Notification%20Form.pdf>

Letter of Intent - Form signed by the Contractor and the MBE/WBE subcontractor, manufacturer or regular dealer that affirms that a portion of said contract is going to be performed by the signed MBE/WBE for the estimated amount (based on quantities and unit prices) listed at the time of bid.
<http://connect.ncdot.gov/letting/LetCentral/Letter%20of%20Intent%20to%20Perform%20as%20a%20Subcontractor.pdf>

Listing of MBE and WBE Subcontractors Form - Form for entering MBE/WBE subcontractors on a project that will meet the Combined MBE/WBE goal. This form is for paper bids only.
[http://connect.ncdot.gov/municipalities/Bid%20Proposals%20for%20LGA%20Content/09%20MBE-WBE%20Subcontractors%20\(State\).docx](http://connect.ncdot.gov/municipalities/Bid%20Proposals%20for%20LGA%20Content/09%20MBE-WBE%20Subcontractors%20(State).docx)

Subcontractor Quote Comparison Sheet - Spreadsheet for showing all subcontractor quotes in the work areas where MBEs and WBEs quoted on the project. This sheet is submitted with good faith effort packages.
<http://connect.ncdot.gov/business/SmallBusiness/Documents/DBE%20Subcontractor%20Quote%20Comparison%20Example.xls>

Combined MBE/WBE Goal

The Combined MBE/WBE Goal for this project is **4.0 %**

The Combined Goal was established utilizing the following anticipated participation for Minority Business Enterprises and Women Business Enterprises:

(A) Minority Business Enterprises **2.0 %**

- (1) *If the anticipated MBE participation is more than zero*, the Contractor shall exercise all necessary and reasonable steps to ensure that MBEs participate in at least the percent of the contract as set forth above.

- (2) *If the anticipated MBE participation is zero*, the Contractor shall make an effort to recruit and use MBEs during the performance of the contract. Any MBE participation obtained shall be reported to the Department.
- (B) Women Business Enterprises **2.0 %**
- (1) *If the anticipated WBE participation is more than zero*, the Contractor shall exercise all necessary and reasonable steps to ensure that WBEs participate in at least the percent of the contract as set forth above.
 - (2) *If the anticipated WBE participation is zero*, the Contractor shall make an effort to recruit and use WBEs during the performance of the contract. Any WBE participation obtained shall be reported to the Department.

The Bidder is required to submit only participation to meet the Combined MBE/WBE Goal. The Combined Goal may be met by submitting all MBE participation, all WBE participation, or a combination of MBE and WBE participation.

Directory of Transportation Firms (Directory)

Real-time information is available about firms doing business with the Department and firms that are certified through NCUCP in the Directory of Transportation Firms. Only firms identified in the Directory as MBE and WBE certified shall be used to meet the Combined MBE/WBE Goal. The Directory can be found at the following link.

<https://www.ebs.nc.gov/VendorDirectory/default.html>

The listing of an individual firm in the directory shall not be construed as an endorsement of the firm's capability to perform certain work.

Listing of MBE/WBE Subcontractors

At the time of bid, bidders shall submit all MBE and WBE participation that they anticipate to use during the life of the contract. Only those identified to meet the Combined MBE/WBE Goal will be considered committed, even though the listing shall include both committed MBE/WBE subcontractors and additional MBE/WBE subcontractors. Any additional MBE/WBE subcontractor participation above the goal will follow the banking guidelines found elsewhere in this provision. All other additional MBE/WBE subcontractor participation submitted at the time of bid will be used toward the Department's overall race-neutral goals. Only those firms with current MBE and WBE certification at the time of bid opening will be acceptable for listing in the bidder's submittal of MBE and WBE participation. The Contractor shall indicate the following required information:

- (A) Electronic Bids

Bidders shall submit a listing of MBE and WBE participation in the appropriate section of the electronic submittal file.

- (1) Submit the names and addresses of MBE and WBE firms identified to participate in the contract. If the bidder uses the updated listing of MBE and WBE firms shown in the electronic submittal file, the bidder may use the dropdown menu to access the name and address of the firms.
- (2) Submit the contract line numbers of work to be performed by each MBE and WBE firm. When no figures or firms are entered, the bidder will be considered to have no MBE or WBE participation.
- (3) The bidder shall be responsible for ensuring that the MBE and WBE are certified at the time of bid by checking the Directory of Transportation Firms. If the firm is not certified at the time of the bid-letting, that MBE's or WBE's participation will not count towards achieving the Combined MBE/WBE goal.

(B) Paper Bids

- (1) *If the Combined MBE/WBE Goal is more than zero,*
 - (a) Bidders, at the time the bid proposal is submitted, shall submit a listing of MBE/WBE participation, including the names and addresses on *Listing of MBE and WBE Subcontractors* contained elsewhere in the contract documents in order for the bid to be considered responsive. Bidders shall indicate the total dollar value of the MBE and WBE participation for the contract.
 - (b) If bidders have no MBE or WBE participation, they shall indicate this on the *Listing of MBE and WBE Subcontractors* by entering the word "None" or the number "0." This form shall be completed in its entirety. **Blank forms will not be deemed to represent zero participation.** Bids submitted that do not have MBE and WBE participation indicated on the appropriate form will not be read publicly during the opening of bids. The Department will not consider these bids for award and the proposal will be rejected.
 - (c) The bidder shall be responsible for ensuring that the MBE/WBE is certified at the time of bid by checking the Directory of Transportation Firms. If the firm is not certified at the time of the bid-letting, that MBE's or WBE's participation will not count towards achieving the Combined MBE/WBE Goal.
- (2) *If the Combined MBE/WBE Goal is zero,* entries on the *Listing of MBE and WBE Subcontractors* are not required for the zero goal, however any MBE or WBE participation that is achieved during the project shall be reported in accordance with requirements contained elsewhere in the special provision.

MBE or WBE Prime Contractor

When a certified MBE or WBE firm bids on a contract that contains a Combined MBE/WBE goal, the firm is responsible for meeting the goal or making good faith efforts to meet the goal, just like any other bidder. In most cases, a MBE or WBE bidder on a contract will meet the Combined MBE/WBE Goal by virtue of the work it performs on the contract with its own forces. However, all the work that is performed by the MBE or WBE bidder and any other similarly certified subcontractors will count toward the goal. The MBE or WBE bidder shall list itself along with any MBE or WBE subcontractors, if any, in order to receive credit toward the goal.

MBE/WBE prime contractors shall also follow Sections A and B listed under *Listing of MBE/WBE Subcontractor* just as a non-MBE/WBE bidder would.

Written Documentation – Letter of Intent

The bidder shall submit written documentation for each MBE/WBE that will be used to meet the Combined MBE/WBE Goal of the contract, indicating the bidder's commitment to use the MBE/WBE in the contract. This documentation shall be submitted on the Department's form titled *Letter of Intent*.

The documentation shall be received in the office of the State Contractor Utilization Engineer or at DBE@ncdot.gov no later than 10:00 a.m. of the sixth calendar day following opening of bids, unless the sixth day falls on an official state holiday. In that situation, it is due in the office of the State Contractor Utilization Engineer no later than 10:00 a.m. on the next official state business day.

If the bidder fails to submit the Letter of Intent from each committed MBE and WBE to be used toward the Combined MBE/WBE Goal, or if the form is incomplete (i.e. both signatures are not present), the MBE/WBE participation will not count toward meeting the Combined MBE/WBE Goal. If the lack of this participation drops the commitment below the Combined MBE/WBE Goal, the Contractor shall submit evidence of good faith efforts for the goal, completed in its entirety, to the State Contractor Utilization Engineer or DBE@ncdot.gov no later than 10:00 a.m. on the eighth calendar day following opening of bids, unless the eighth day falls on an official state holiday. In that situation, it is due in the office of the State Contractor Utilization Engineer no later than 10:00 a.m. on the next official state business day.

Banking MBE/WBE Credit

If the bid of the lowest responsive bidder exceeds \$500,000 and if the committed MBE/WBE participation submitted exceeds the algebraic sum of the Combined MBE/WBE Goal by \$1,000 or more, the excess will be placed on deposit by the Department for future use by the bidder. Separate accounts will be maintained for MBE and WBE participation and these may accumulate for a period not to exceed 24 months.

When the apparent lowest responsive bidder fails to submit sufficient participation by MBE and WBE firms to meet the advertised goal, as part of the good faith effort, the Department will consider allowing the bidder to withdraw funds to meet the Combined MBE/WBE Goal as long as there are adequate funds available from the bidder's MBE and WBE bank accounts.

Submission of Good Faith Effort

If the bidder fails to meet or exceed the Combined MBE/WBE Goal, the apparent lowest responsive bidder shall submit to the Department documentation of adequate good faith efforts made to reach that specific goal.

A hard copy and an electronic copy of this information shall be received in the office of the State Contractor Utilization Engineer or at DBE@ncdot.gov no later than 10:00 a.m. on the sixth calendar day following opening of bids unless the sixth day falls on an official state holiday. In that situation, it would be due in the office of the State Contractor Utilization Engineer no later than 10:00 a.m. on the next official state business day. If the contractor cannot send the information electronically, then one complete set and 5 copies of this information shall be received under the same time constraints above.

Note: Where the information submitted includes repetitious solicitation letters, it will be acceptable to submit a representative letter along with a distribution list of the firms that were solicited. Documentation of MBE/WBE quotations shall be a part of the good faith effort submittal. This documentation may include written subcontractor quotations, telephone log notations of verbal quotations, or other types of quotation documentation.

Consideration of Good Faith Effort for Projects with a Combined MBE/WBE Goal More Than Zero

Adequate good faith efforts mean that the bidder took all necessary and reasonable steps to achieve the goal which, by their scope, intensity, and appropriateness, could reasonably be expected to obtain sufficient MBE/WBE participation. Adequate good faith efforts also mean that the bidder actively and aggressively sought MBE/WBE participation. Mere *pro forma* efforts are not considered good faith efforts.

The Department will consider the quality, quantity, and intensity of the different kinds of efforts a bidder has made. Listed below are examples of the types of actions a bidder will take in making a good faith effort to meet the goals and are not intended to be exclusive or exhaustive, nor is it intended to be a mandatory checklist.

- (A) Soliciting through all reasonable and available means (e.g. attendance at pre-bid meetings, advertising, written notices, use of verifiable electronic means through the use of the NCDOT Directory of Transportation Firms) the interest of all certified MBEs/WBEs that are also prequalified subcontractors. The bidder must solicit this interest within at least 10 days prior to bid opening to allow the MBEs/WBEs to respond to the solicitation. Solicitation shall provide the opportunity to MBEs/WBEs within the Division and surrounding Divisions where the project is located. The bidder must determine with certainty if the MBEs/WBEs are interested by taking appropriate steps to follow up initial solicitations.

- (B) Selecting portions of the work to be performed by MBEs/WBEs in order to increase the likelihood that the Combined MBE/WBE Goal will be achieved.
- (1) Where appropriate, break out contract work items into economically feasible units to facilitate MBE/WBE participation, even when the prime contractor might otherwise prefer to perform these work items with its own forces.
 - (2) Negotiate with subcontractors to assume part of the responsibility to meet the advertised goal when the work to be sublet includes potential for MBE/WBE participation (2nd and 3rd tier subcontractors).
- (C) Providing interested certified MBEs/WBEs that are also prequalified subcontractors with adequate information about the plans, specifications, and requirements of the contract in a timely manner to assist them in responding to a solicitation.
- (D) (1) Negotiating in good faith with interested MBEs/WBEs. It is the bidder's responsibility to make a portion of the work available to MBE/WBE subcontractors and suppliers and to select those portions of the work or material needs consistent with the available MBE/WBE subcontractors and suppliers, so as to facilitate MBE/WBE participation. Evidence of such negotiation includes the names, addresses, and telephone numbers of MBEs/WBEs that were considered; a description of the information provided regarding the plans and specifications for the work selected for subcontracting; and evidence as to why additional agreements could not be reached for MBEs/WBEs to perform the work.
- (2) A bidder using good business judgment would consider a number of factors in negotiating with subcontractors, including MBE/WBE subcontractors, and would take a firm's price and capabilities as well as the advertised goal into consideration. However, the fact that there may be some additional costs involved in finding and using MBEs/WBEs is not in itself sufficient reason for a bidder's failure to meet the contract goal, as long as such costs are reasonable. Also, the ability or desire of a prime contractor to perform the work of a contract with its own organization does not relieve the bidder of the responsibility to make good faith efforts. Bidding contractors are not, however, required to accept higher quotes from MBEs/WBEs if the price difference is excessive or unreasonable.
- (E) Not rejecting MBEs/WBEs as being unqualified without sound reasons based on a thorough investigation of their capabilities. The bidder's standing within its industry, membership in specific groups, organizations, or associates and political or social affiliations (for example, union vs. non-union employee status) are not legitimate causes for the rejection or non-solicitation of bids in the bidder's efforts to meet the project goal.
- (F) Making efforts to assist interested MBEs/WBEs in obtaining bonding, lines of credit, or insurance as required by the recipient or bidder.
- (G) Making efforts to assist interested MBEs/WBEs in obtaining necessary equipment, supplies, materials, or related assistance or services.

- (H) Effectively using the services of available minority/women community organizations; minority/women contractors' groups; Federal, State, and local minority/women business assistance offices; and other organizations as allowed on a case-by-case basis to provide assistance in the recruitment and placement of MBEs/WBEs. Contact within 7 days from the bid opening the Business Opportunity and Work Force Development Unit at BOWD@ncdot.gov to give notification of the bidder's inability to get MBE or WBE quotes.
- (I) Any other evidence that the bidder submits which shows that the bidder has made reasonable good faith efforts to meet the advertised goal.

In addition, the Department may take into account the following:

- (1) Whether the bidder's documentation reflects a clear and realistic plan for achieving the Combined MBE/WBE Goal.
- (2) The bidders' past performance in meeting the contract goal.
- (3) The performance of other bidders in meeting the advertised goal. For example, when the apparent successful bidder fails to meet the goal, but others meet it, you may reasonably raise the question of whether, with additional reasonable efforts the apparent successful bidder could have met the goal. If the apparent successful bidder fails to meet the advertised goal, but meets or exceeds the average MBE and WBE participation obtained by other bidders, the Department may view this, in conjunction with other factors, as evidence of the apparent successful bidder having made a good faith effort.

If the Department does not award the contract to the apparent lowest responsive bidder, the Department reserves the right to award the contract to the next lowest responsive bidder that can satisfy to the Department that the Combined MBE/WBE Goal can be met or that an adequate good faith effort has been made to meet the advertised goal.

Non-Good Faith Appeal

The State Prequalification Engineer will notify the contractor verbally and in writing of non-good faith. A contractor may appeal a determination of non-good faith made by the Goal Compliance Committee. If a contractor wishes to appeal the determination made by the Committee, they shall provide written notification to the State Prequalification Engineer or at DBE@ncdot.gov. The appeal shall be made within 2 business days of notification of the determination of non-good faith.

Counting MBE/WBE Participation Toward Meeting the Combined MBE/WBE Goal

(A) Participation

The total dollar value of the participation by a committed MBE/WBE will be counted toward the contract goal requirements. The total dollar value of participation by a committed MBE/WBE will be based upon the value of work actually performed by the MBE/WBE and the actual payments to MBE/WBE firms by the Contractor.

(B) Joint Checks

Prior notification of joint check use shall be required when counting MBE/WBE participation for services or purchases that involves the use of a joint check. Notification shall be through submission of Form JC-1 (*Joint Check Notification Form*) and the use of joint checks shall be in accordance with the Department's Joint Check Procedures.

(C) Subcontracts (Non-Trucking)

A MBE/WBE may enter into subcontracts. Work that a MBE subcontracts to another MBE firm may be counted toward the anticipated MBE participation. The same holds true for work that a WBE subcontracts to another WBE firm. Work that a MBE/WBE subcontracts to a non-MBE/WBE firm does not count toward the contract goal requirement. It should be noted that every effort shall be made by MBE and WBE contractors to subcontract to the same certification (i.e., MBEs to MBEs and WBEs to WBEs), in order to fulfill the MBE or WBE participation breakdown. This, however, may not always be possible due to the limitation of firms in the area. If the MBE or WBE firm shows a good faith effort has been made to reach out to similarly certified firms and there is no interest or availability, and they can get assistance from other certified firms, the Engineer will not hold the prime responsible for meeting the individual MBE or WBE breakdown. If a MBE or WBE contractor or subcontractor subcontracts a significantly greater portion of the work of the contract than would be expected on the basis of standard industry practices, it shall be presumed that the MBE or WBE is not performing a commercially useful function.

(D) Joint Venture

When a MBE or WBE performs as a participant in a joint venture, the Contractor may count toward its contract goal requirement a portion of the total value of participation with the MBE or WBE in the joint venture, that portion of the total dollar value being a distinct clearly defined portion of work that the MBE or WBE performs with its forces.

(E) Suppliers

A contractor may count toward its MBE/ WBE requirement 60 percent of its expenditures for materials and supplies required to complete the contract and obtained from a MBE or WBE regular dealer and 100 percent of such expenditures from a MBE or WBE manufacturer.

(F) Manufacturers and Regular Dealers

A contractor may count toward its MBE/ WBE requirement the following expenditures to MBE/WBE firms that are not manufacturers or regular dealers:

- (1) The fees or commissions charged by a MBE/WBE firm for providing a *bona fide* service, such as professional, technical, consultant, or managerial services, or for providing bonds or insurance specifically required for the performance of

a DOT-assisted contract, provided the fees or commissions are determined to be reasonable and not excessive as compared with fees and commissions customarily allowed for similar services.

- (2) With respect to materials or supplies purchased from a MBE/WBE, which is neither a manufacturer nor a regular dealer, count the entire amount of fees or commissions charged for assistance in the procurement of the materials and supplies, or fees or transportation charges for the delivery of materials or supplies required on a job site (but not the cost of the materials and supplies themselves), provided the fees are determined to be reasonable and not excessive as compared with fees customarily allowed for similar services.

Commercially Useful Function

(A) MBE/WBE Utilization

The Contractor may count toward its contract goal requirement only expenditures to MBEs and WBEs that perform a commercially useful function in the work of a contract. A MBE/WBE performs a commercially useful function when it is responsible for execution of the work of the contract and is carrying out its responsibilities by actually performing, managing, and supervising the work involved. To perform a commercially useful function, the MBE/WBE shall also be responsible with respect to materials and supplies used on the contract, for negotiating price, determining quality and quantity, ordering the material and installing (where applicable) and paying for the material itself. To determine whether a MBE/WBE is performing a commercially useful function, the Department will evaluate the amount of work subcontracted, industry practices, whether the amount the firm is to be paid under the contract is commensurate with the work it is actually performing and the MBE/WBE credit claimed for its performance of the work, and any other relevant factors. If it is determined that a MBE or WBE is not performing a Commercially Useful Function, the contractor may present evidence to rebut this presumption to the Department.

(B) MBE/WBE Utilization in Trucking

The following factors will be used to determine if a MBE or WBE trucking firm is performing a commercially useful function:

- (1) The MBE/WBE shall be responsible for the management and supervision of the entire trucking operation for which it is responsible on a particular contract, and there shall not be a contrived arrangement for the purpose of meeting the Combined MBE/WBE Goal.
- (2) The MBE/WBE shall itself own and operate at least one fully licensed, insured, and operational truck used on the contract.

- (3) The MBE/WBE receives credit for the total value of the transportation services it provides on the contract using trucks it owns, insures, and operates using drivers it employs.
- (4) The MBE may subcontract the work to another MBE firm, including an owner-operator who is certified as a MBE. The same holds true that a WBE may subcontract the work to another WBE firm, including an owner-operator who is certified as a WBE. When this occurs, the MBE or WBE who subcontracts work receives credit for the total value of the transportation services the subcontracted MBE or WBE provides on the contract. It should be noted that every effort shall be made by MBE and WBE contractors to subcontract to the same certification (i.e., MBEs to MBEs and WBEs to WBEs), in order to fulfill the participation breakdown. This, however, may not always be possible due to the limitation of firms in the area. If the MBE or WBE firm shows a good faith effort has been made to reach out to similarly certified transportation service providers and there is no interest or availability, and they can get assistance from other certified providers, the Engineer will not hold the prime responsible for meeting the individual MBE or WBE participation breakdown.
- (5) The MBE/WBE may also subcontract the work to a non-MBE/WBE firm, including from an owner-operator. The MBE/WBE who subcontracts the work to a non-MBE/WBE is entitled to credit for the total value of transportation services provided by the non-MBE/WBE subcontractor not to exceed the value of transportation services provided by MBE/WBE-owned trucks on the contract. Additional participation by non-MBE/WBE subcontractors receives credit only for the fee or commission it receives as a result of the subcontract arrangement. The value of services performed under subcontract agreements between the MBE/WBE and the Contractor will not count towards the MBE/WBE contract requirement.
- (6) A MBE/WBE may lease truck(s) from an established equipment leasing business open to the general public. The lease must indicate that the MBE/WBE has exclusive use of and control over the truck. This requirement does not preclude the leased truck from working for others during the term of the lease with the consent of the MBE/WBE, so long as the lease gives the MBE/WBE absolute priority for use of the leased truck. This type of lease may count toward the MBE/WBE's credit as long as the driver is under the MBE/WBE's payroll.
- (7) Subcontracted/leased trucks shall display clearly on the dashboard the name of the MBE/WBE that they are subcontracted/leased to and their own company name if it is not identified on the truck itself. Magnetic door signs are not permitted.

MBE/WBE Replacement

When a Contractor has relied on a commitment to a MBE or WBE subcontractor (or an approved substitute MBE or WBE subcontractor) to meet all or part of a contract goal requirement, the contractor shall not terminate the MBE/WBE subcontractor for convenience. This includes, but is not limited to, instances in which the Contractor seeks to perform the work of the terminated

subcontractor with another MBE/WBE subcontractor, a non-MBE/WBE subcontractor, or with the Contractor's own forces or those of an affiliate.

The Contractor must give notice in writing both by certified mail and email to the MBE/WBE subcontractor, with a copy to the Engineer of its intent to request to terminate and/or substitute, and the reason for the request. The Contractor must give the MBE/WBE subcontractor five (5) business days to respond to the Contractor's Notice of Intent to Request Termination and/or Substitution. If the MBE/WBE subcontractor objects to the intended termination/substitution, the MBE/WBE, within five (5) business days must advise the Contractor and the Department of the reasons why the action should not be approved. The five-day notice period shall begin on the next business day after written notice is provided to the MBE/WBE subcontractor.

A committed MBE/WBE subcontractor may only be terminated after receiving the Department's written approval based upon a finding of good cause for the proposed termination and/or substitution. For purposes of this section, good cause shall include the following circumstances:

- (a) The listed MBE/WBE subcontractor fails or refuses to execute a written contract;
- (b) The listed MBE/WBE subcontractor fails or refuses to perform the work of its subcontract in a way consistent with normal industry standards. Provided, however, that good cause does not exist if the failure or refusal of the MBE/WBE subcontractor to perform its work on the subcontract results from the bad faith or discriminatory action of the prime contractor;
- (c) The listed MBE/WBE subcontractor fails or refuses to meet the prime contractor's reasonable, nondiscriminatory bond requirements;
- (d) The listed MBE/WBE subcontractor becomes bankrupt, insolvent, or exhibits credit unworthiness;
- (e) The listed MBE/WBE subcontractor is ineligible to work on public works projects because of suspension and debarment proceedings pursuant to 2 CFR Parts 180, 215 and 1,200 or applicable state law;
- (f) The listed MBE/WBE subcontractor is not a responsible contractor;
- (g) The listed MBE/WBE voluntarily withdraws from the project and provides written notice of withdrawal;
- (h) The listed MBE/WBE is ineligible to receive MBE/WBE credit for the type of work required;
- (i) A MBE/WBE owner dies or becomes disabled with the result that the listed MBE/WBE contractor is unable to complete its work on the contract;
- (j) Other documented good cause that compels the termination of the MBE/WBE subcontractor. Provided, that good cause does not exist if the prime contractor seeks to terminate a MBE/WBE it relied upon to obtain the contract so that the prime contractor can self-perform the work for which the MBE/WBE contractor was engaged or so that the prime contractor can substitute another MBE/WBE or non-MBE/WBE contractor after contract award.

The Contractor shall comply with the following for replacement of a committed MBE/WBE:

(A) Performance Related Replacement

When a committed MBE/WBE is terminated for good cause as stated above, an additional MBE/WBE that was submitted at the time of bid may be used to fulfill the MBE/WBE commitment to meet the Combined MBE/WBE Goal. A good faith effort will only be required for removing a committed MBE/WBE if there were no additional MBE/WBEs submitted at the time of bid to cover the same amount of work as the MBE/WBE that was terminated.

If a replacement MBE/WBE is not found that can perform at least the same amount of work as the terminated MBE/WBE, the Contractor shall submit a good faith effort documenting the steps taken. Such documentation shall include, but not be limited to, the following:

- (1) Copies of written notification to MBE/WBEs that their interest is solicited in contracting the work defaulted by the previous MBE/WBE or in subcontracting other items of work in the contract.
- (2) Efforts to negotiate with MBE/WBEs for specific subbids including, at a minimum:
 - (a) The names, addresses, and telephone numbers of MBE/WBEs who were contacted.
 - (b) A description of the information provided to MBE/WBEs regarding the plans and specifications for portions of the work to be performed.
- (3) A list of reasons why MBE/WBE quotes were not accepted.
- (4) Efforts made to assist the MBE/WBEs contacted, if needed, in obtaining bonding or insurance required by the Contractor.

(B) Decertification Replacement

- (1) When a committed MBE/WBE is decertified by the Department after the SAF (*Subcontract Approval Form*) has been received by the Department, the Department will not require the Contractor to solicit replacement MBE/WBE participation equal to the remaining work to be performed by the decertified firm. The participation equal to the remaining work performed by the decertified firm will count toward the contract goal requirement.
- (2) When a committed MBE/WBE is decertified prior to the Department receiving the SAF (*Subcontract Approval Form*) for the named MBE/WBE firm, the Contractor shall take all necessary and reasonable steps to replace the MBE/WBE subcontractor with another MBE/WBE subcontractor to perform at least the same amount of work to meet the Combined MBE/WBE goal requirement. If a MBE/WBE firm is not found to do the same amount of work, a good faith effort must be submitted to NCDOT (see A herein for required documentation).
- (3) Exception: If the MBE/WBE's ineligibility is caused solely by its having exceeded the size standard during the performance of the contract, the Department will not require the Contractor to solicit replacement MBE/WBE participation equal to the remaining work to be performed by the decertified firm. The participation equal to the remaining work performed by the decertified firm will count toward the contract goal requirement and overall goal.

All requests for replacement of a committed MBE/WBE firm shall be submitted to the Engineer for approval on Form RF-1 (*DBE Replacement Request*). If the Contractor fails to follow this procedure, the Contractor may be disqualified from further bidding for a period of up to 6 months.

Changes in the Work

When the Engineer makes changes that result in the reduction or elimination of work to be performed by a committed MBE/WBE, the Contractor will not be required to seek additional participation. When the Engineer makes changes that result in additional work to be performed by a MBE/WBE based upon the Contractor's commitment, the MBE/WBE shall participate in additional work to the same extent as the MBE/WBE participated in the original contract work.

When the Engineer makes changes that result in extra work, which has more than a minimal impact on the contract amount, the Contractor shall seek additional participation by MBEs/WBEs unless otherwise approved by the Engineer.

When the Engineer makes changes that result in an alteration of plans or details of construction, and a portion or all of the work had been expected to be performed by a committed MBE/WBE, the Contractor shall seek participation by MBEs/WBEs unless otherwise approved by the Engineer.

When the Contractor requests changes in the work that result in the reduction or elimination of work that the Contractor committed to be performed by a MBE/WBE, the Contractor shall seek additional participation by MBEs/WBEs equal to the reduced MBE/WBE participation caused by the changes.

Reports and Documentation

A SAF (*Subcontract Approval Form*) shall be submitted for all work which is to be performed by a MBE/WBE subcontractor. The Department reserves the right to require copies of actual subcontract agreements involving MBE/WBE subcontractors.

When using transportation services to meet the contract commitment, the Contractor shall submit a proposed trucking plan in addition to the SAF. The plan shall be submitted prior to beginning construction on the project. The plan shall include the names of all trucking firms proposed for use, their certification type(s), the number of trucks owned by the firm, as well as the individual truck identification numbers, and the line item(s) being performed.

Within 30 calendar days of entering into an agreement with a MBE/WBE for materials, supplies or services, not otherwise documented by the SAF as specified above, the Contractor shall furnish the Engineer a copy of the agreement. The documentation shall also indicate the percentage (60% or 100%) of expenditures claimed for MBE/WBE credit.

Reporting Minority and Women Business Enterprise Participation

The Contractor shall provide the Engineer with an accounting of payments made to all MBE/WBE firms, including material suppliers and contractors at all levels (prime, subcontractor, or second tier subcontractor). This accounting shall be furnished to the Engineer for any given month by the end of the following month. Failure to submit this information accordingly may result in the following action:

- (A) Withholding of money due in the next partial pay estimate; or

- (B) Removal of an approved contractor from the prequalified bidders' list or the removal of other entities from the approved subcontractors list.

While each contractor (prime, subcontractor, 2nd tier subcontractor) is responsible for accurate accounting of payments to MBEs/WBEs, it shall be the prime contractor's responsibility to report all monthly and final payment information in the correct reporting manner.

Failure on the part of the Contractor to submit the required information in the time frame specified may result in the disqualification of that contractor and any affiliate companies from further bidding until the required information is submitted.

Failure on the part of any subcontractor to submit the required information in the time frame specified may result in the disqualification of that contractor and any affiliate companies from being approved for work on future DOT projects until the required information is submitted.

Contractors reporting transportation services provided by non-MBE/WBE lessees shall evaluate the value of services provided during the month of the reporting period only.

At any time, the Engineer can request written verification of subcontractor payments.

The Contractor shall report the accounting of payments through the Department's Payment Tracking System.

Failure to Meet Contract Requirements

Failure to meet contract requirements in accordance with Subarticle 102-15(J) of the *2018 Standard Specifications* may be cause to disqualify the Contractor.

CONTRACTOR'S LICENSE REQUIREMENTS:

(7-1-95)

102-14

SP1 G88

If the successful bidder does not hold the proper license to perform any plumbing, heating, air conditioning, or electrical work in this contract, he will be required to sublet such work to a contractor properly licensed in accordance with *Article 2 of Chapter 87 of the General Statutes* (licensing of heating, plumbing, and air conditioning contractors) and *Article 4 of Chapter 87 of the General Statutes* (licensing of electrical contractors).

RESTRICTIONS ON ITS EQUIPMENT AND SERVICES:

(11-17-20)

SP01 G090

All telecommunications, video or other ITS equipment or services installed or utilized on this project must be in conformance with UNIFORM ADMINISTRATIVE REQUIREMENTS, COST PRINCIPLES, AND AUDIT REQUIREMENTS FOR FEDERAL AWARDS **2 CFR, § 200.216** **Prohibition on certain telecommunications and video surveillance services or equipment.**

USE OF UNMANNED AIRCRAFT SYSTEM (UAS):

(8-20-19)

SP1 G092

The Contractor shall adhere to all Federal, State and Local regulations and guidelines for the use of Unmanned Aircraft Systems (UAS). This includes but is not limited to US 14 CFR Part 107 *Small UAS Rule*, NC GS 15A-300.2 *Regulation of launch and recovery sites*, NC GS 63-95 *Training required for the operation of unmanned aircraft systems*, NC GS 63-96 *Permit required for commercial operation of unmanned aircraft system*, and NCDOT UAS Policy. The required operator certifications include possessing a current Federal Aviation Administration (FAA) Remote Pilot Certificate, a NC UAS Operator Permit as well as operating a UAS registered with the FAA.

Prior to beginning operations, the Contractor shall complete the NCDOT UAS – Flight Operation Approval Form and submit it to the Engineer for approval. All UAS operations shall be approved by the Engineer prior to beginning the operations.

All contractors or subcontractors operating UAS shall have UAS specific general liability insurance to cover all operations under this contract.

The use of UAS is at the Contractor's discretion. No measurement or payment will be made for the use of UAS. In the event that the Department directs the Contractor to utilize UAS, payment will be in accordance with Article 104-7 Extra Work.

EQUIPMENT IDLING GUIDELINES:

(1-19-21)

107

SP1 G096

Exercise reduced fuel consumption and reduced equipment emissions during the construction of all work associated with this contract. Employees engaged in the construction of this project should turn off vehicles when stopped for more than thirty (30) minutes and off-highway equipment should idle no longer than fifteen (15) consecutive minutes.

These guidelines for turning off vehicles and equipment when idling do not apply to:

1. Idling when queuing.
2. Idling to verify the vehicle is in safe operating condition.
3. Idling for testing, servicing, repairing or diagnostic purposes.
4. Idling necessary to accomplish work for which the vehicle was designed (such as operating a crane, mixing concrete, etc.).
5. Idling required to bring the machine system to operating temperature.
6. Emergency vehicles, utility company, construction, and maintenance vehicles where the engines must run to perform needed work.
7. Idling to ensure safe operation of the vehicle.
8. Idling when the propulsion engine is providing auxiliary power for other than heating or air conditioning. (such as hydraulic systems for pavers)
9. When specific traffic, safety, or emergency situations arise.
10. If the ambient temperature is less than 32 degrees Fahrenheit. Limited idling to provide for the safety of vehicle occupants (e.g. to run the heater).

11. If the ambient temperature is greater than 90 degrees Fahrenheit. Limited idling to provide for the safety of vehicle occupants of off-highway equipment (e.g. to run the air conditioning) no more than 30 minutes.

12. Diesel powered vehicles may idle for up to 30 minutes to minimize restart problems. Any vehicle, truck, or equipment in which the primary source of fuel is natural gas or electricity is exempt from the idling limitations set forth in this special provision.

SUBSURFACE INFORMATION:

(7-1-95)

450

SP1 G112 C

Subsurface information is available on the roadway and structure portions of this project.

PORTABLE CONCRETE BARRIER - (Partial Payments for Materials):

(7-1-95) (Rev. 8-16-11)

1170-4

SP1 G121

When so authorized by the Engineer, partial materials payments will be made up to 95 percent of the delivered cost of portable concrete barrier, provided that these materials have been delivered on the project and stored in an acceptable manner, and further provided the documents listed in Subarticle 109-5(C) of the *2018 Standard Specifications* have been furnished to the Engineer.

The provisions of Subarticle 109-5(B) of the *2018 Standard Specifications* will apply to the portable concrete barrier.

REMOVABLE PAVEMENT MARKINGS - (Partial Payments for Materials):

(7-1-95) (Rev. 8-16-11)

1205-10

SP1 G124

When so authorized by the Engineer, partial materials payments will be made up to 95 percent of the delivered cost of pavement marking tape, provided that these materials have been delivered on or in the vicinity of the project, stored in an acceptable manner, not to exceed the shelf life recommended by the manufacturer, and further provided the documents listed in Subarticle 109-5(C) of the *2018 Standard Specifications* have been furnished to the Engineer.

The Contractor shall be responsible for the material and the satisfactory performance of the material when used in the work.

The provisions of Article 109-6 of the *2018 Standard Specifications* will not apply to removable pavement marking materials.

MAINTENANCE OF THE PROJECT:

(11-20-07) (Rev. 1-17-12)

104-10

SP1 G125

Revise the *2018 Standard Specifications* as follows:

Page 1-39, Article 104-10 Maintenance of the Project, line 25, add the following after the first sentence of the first paragraph:

All guardrail/guiderail within the project limits shall be included in this maintenance.

Page 1-39, Article 104-10 Maintenance of the Project, line 30, add the following as the last sentence of the first paragraph:

The Contractor shall perform weekly inspections of guardrail and guiderail and shall report damages to the Engineer on the same day of the weekly inspection. *Where damaged guardrail or guiderail is repaired or replaced as a result of maintaining the project in accordance with this article, such repair or replacement shall be performed within 7 consecutive calendar days of such inspection report.*

Page 1-39, Article 104-10 Maintenance of the Project, lines 42-44, replace the last sentence of the last paragraph with the following:

The Contractor will not be directly compensated for any maintenance operations necessary, except for maintenance of guardrail/guiderail, as this work will be considered incidental to the work covered by the various contract items. The provisions of Article 104-7, Extra Work, and Article 104-8, Compensation and Record Keeping will apply to authorized maintenance of guardrail/guiderail. Performance of weekly inspections of guardrail/guiderail, and the damage reports required as described above, will be considered to be an incidental part of the work being paid for by the various contract items.

ELECTRONIC BIDDING:

(2-19-19)

101, 102, 103

SP1 G140

Revise the *2018 Standard Specifications* as follows:

Page 1-4, Article 101-3, DEFINITIONS, BID (OR PROPOSAL) *Electronic Bid*, line 1, replace “Bid Express®” with “the approved electronic bidding provider”.

Page 1-15, Subarticle 102-8(B), Electronic Bids, lines 39-40, replace “to Bid Express®” with “via the approved electronic bidding provider”.

Page 1-15, Subarticle 102-8(B)(1), Electronic Bids, line 41, delete “from Bid Express®”

Page 1-17, Subarticle 102-9(C)(2), Electronic Bids, line 21, replace “Bid Express® miscellaneous folder within the .ebs” with “electronic submittal”.

Page 1-29, Subarticle 103-4(C)(2), Electronic Bids, line 32, replace “.ebs miscellaneous data file of Expedite” with “electronic submittal file”

AWARD LIMITS:

(4-19-22)

103

SP1 G141

Revise the *2018 Standard Specifications* as follows:

Page 1-29, Subarticle 103-4(C), Award Limits, line 4-8, delete and replace the first sentence in the first paragraph with the following:

A bidder who desires to bid on more than one project on which bids are to be opened in the same letting and who desires to avoid receiving an award of more projects than he is equipped to handle, may bid on any number of projects but may limit the total amount of work awarded to him on selected projects by completing the form Award Limits on Multiple Projects for each project subject to the award limit.

TWELVE MONTH GUARANTEE:

(7-15-03)

108

SP1 G145

- (A) The Contractor shall guarantee materials and workmanship against latent and patent defects arising from faulty materials, faulty workmanship or negligence for a period of twelve months following the date of final acceptance of the work for maintenance and shall replace such defective materials and workmanship without cost to the Department. The Contractor will not be responsible for damage due to faulty design, normal wear and tear, for negligence on the part of the Department, and/or for use in excess of the design.
- (B) Where items of equipment or material carry a manufacturer's guarantee for any period in excess of twelve months, then the manufacturer's guarantee shall apply for that particular piece of equipment or material. The Department's first remedy shall be through the manufacturer although the Contractor is responsible for invoking the warranted repair work with the manufacturer. The Contractor's responsibility shall be limited to the term of the manufacturer's guarantee. NCDOT would be afforded the same warranty as provided by the Manufacturer.

This guarantee provision shall be invoked only for major components of work in which the Contractor would be wholly responsible for under the terms of the contract. Examples would include pavement structures, bridge components, and sign structures. This provision will not be used as a mechanism to force the Contractor to return to the project to make repairs or perform additional work that the Department would normally compensate the Contractor for. In addition, routine maintenance activities (i.e. mowing grass, debris removal, ruts in earth shoulders,) are not parts of this guarantee.

Appropriate provisions of the payment and/or performance bonds shall cover this guarantee for the project.

To ensure uniform application statewide the Division Engineer will forward details regarding the circumstances surrounding any proposed guarantee repairs to the Chief Engineer for review and approval prior to the work being performed.

OUTSOURCING OUTSIDE THE USA:

(9-21-04) (Rev. 5-16-06)

SP1 G150

All work on consultant contracts, services contracts, and construction contracts shall be performed in the United States of America. No work shall be outsourced outside of the United States of America.

Outsourcing for the purpose of this provision is defined as the practice of subcontracting labor, work, services, staffing, or personnel to entities located outside of the United States.

The North Carolina Secretary of Transportation shall approve exceptions to this provision in writing.

EROSION AND SEDIMENT CONTROL/STORMWATER CERTIFICATION:

(1-16-07) (Rev 12-15-20)

105-16, 225-2, 16

SP1 G180

General

Schedule and conduct construction activities in a manner that will minimize soil erosion and the resulting sedimentation and turbidity of surface waters. Comply with the requirements herein regardless of whether or not a National Pollution discharge Elimination System (NPDES) permit for the work is required.

Establish a chain of responsibility for operations and subcontractors' operations to ensure that the *Erosion and Sediment Control/Stormwater Pollution Prevention Plan* is implemented and maintained over the life of the contract.

- (A) *Certified Supervisor* - Provide a certified Erosion and Sediment Control/Stormwater Supervisor to manage the Contractor and subcontractor operations, insure compliance with Federal, State and Local ordinances and regulations, and manage the Quality Control Program.
- (B) *Certified Foreman* - Provide a certified, trained foreman for each construction operation that increases the potential for soil erosion or the possible sedimentation and turbidity of surface waters.
- (C) *Certified Installer* - Provide a certified installer to install or direct the installation for erosion or sediment/stormwater control practices.
- (D) *Certified Designer* - Provide a certified designer for the design of the erosion and sediment control/stormwater component of reclamation plans and, if applicable, for the design of the project erosion and sediment control/stormwater plan.

Roles and Responsibilities

- (A) *Certified Erosion and Sediment Control/Stormwater Supervisor* - The Certified Supervisor shall be Level II and responsible for ensuring the erosion and sediment control/stormwater plan is adequately implemented and maintained on the project and for conducting the quality control program. The Certified Supervisor shall be on the project within 24 hours

notice from initial exposure of an erodible surface to the project's final acceptance. Perform the following duties:

- (1) Manage Operations - Coordinate and schedule the work of subcontractors so that erosion and sediment control/stormwater measures are fully executed for each operation and in a timely manner over the duration of the contract.
 - (a) Oversee the work of subcontractors so that appropriate erosion and sediment control/stormwater preventive measures are conformed to at each stage of the work.
 - (b) Prepare the required National Pollutant Discharge Elimination System (NPDES) Inspection Record and submit to the Engineer.
 - (c) Attend all weekly or monthly construction meetings to discuss the findings of the NPDES inspection and other related issues.
 - (d) Implement the erosion and sediment control/stormwater site plans requested.
 - (e) Provide any needed erosion and sediment control/stormwater practices for the Contractor's temporary work not shown on the plans, such as, but not limited to work platforms, temporary construction, pumping operations, plant and storage yards, and cofferdams.
 - (f) Acquire applicable permits and comply with requirements for borrow pits, dewatering, and any temporary work conducted by the Contractor in jurisdictional areas.
 - (g) Conduct all erosion and sediment control/stormwater work in a timely and workmanlike manner.
 - (h) Fully perform and install erosion and sediment control/stormwater work prior to any suspension of the work.
 - (i) Coordinate with Department, Federal, State and Local Regulatory agencies on resolution of erosion and sediment control/stormwater issues due to the Contractor's operations.
 - (j) Ensure that proper cleanup occurs from vehicle tracking on paved surfaces or any location where sediment leaves the Right-of-Way.
 - (k) Have available a set of erosion and sediment control/stormwater plans that are initialed and include the installation date of Best Management Practices. These practices shall include temporary and permanent groundcover and be properly updated to reflect necessary plan and field changes for use and review by Department personnel as well as regulatory agencies.

- (2) Requirements set forth under the NPDES Permit - The Department's NPDES Stormwater permit (NCS000250) outlines certain objectives and management measures pertaining to construction activities. The permit references *NCG010000, General Permit to Discharge Stormwater* under the NPDES, and states that the Department shall incorporate the applicable requirements into its delegated Erosion and Sediment Control Program for construction activities disturbing one or more acres of land. The Department further incorporates these requirements on all contracted bridge and culvert work at jurisdictional waters, regardless of size. Some of the requirements are, but are not limited to:

- (a) Control project site waste to prevent contamination of surface or ground waters of the state, i.e. from equipment operation/maintenance, construction materials, concrete washout, chemicals, litter, fuels, lubricants, coolants, hydraulic fluids, any other petroleum products, and sanitary waste.
 - (b) Inspect erosion and sediment control/stormwater devices and stormwater discharge outfalls at least once every 7 calendar days and within 24 hours after a rainfall event equal to or greater than 1.0 inch that occurs within a 24 hour period. Additional monitoring may be required at the discretion of Division of Water Resources personnel if the receiving stream is 303(d) listed for turbidity and the project has had documented problems managing turbidity.
 - (c) Maintain an onsite rain gauge or use the Department's Multi-Sensor Precipitation Estimate website to maintain a daily record of rainfall amounts and dates.
 - (d) Maintain erosion and sediment control/stormwater inspection records for review by Department and Regulatory personnel upon request.
 - (e) Implement approved reclamation plans on all borrow pits, waste sites and staging areas.
 - (f) Maintain a log of turbidity test results as outlined in the Department's Procedure for Monitoring Borrow Pit Discharge.
 - (g) Provide secondary containment for bulk storage of liquid materials.
 - (h) Provide training for employees concerning general erosion and sediment control/stormwater awareness, the Department's NPDES Stormwater Permit NCS000250 requirements, and the applicable requirements of the *General Permit, NCG010000*.
 - (i) Report violations of the NPDES permit to the Engineer immediately who will notify the Division of Water Quality Regional Office within 24 hours of becoming aware of the violation.
- (3) Quality Control Program - Maintain a quality control program to control erosion, prevent sedimentation and follow provisions/conditions of permits. The quality control program shall:
- (a) Follow permit requirements related to the Contractor and subcontractors' construction activities.
 - (b) Ensure that all operators and subcontractors on site have the proper erosion and sediment control/stormwater certification.
 - (c) Notify the Engineer when the required certified erosion and sediment control/stormwater personnel are not available on the job site when needed.
 - (d) Conduct the inspections required by the NPDES permit.
 - (e) Take corrective actions in the proper timeframe as required by the NPDES permit for problem areas identified during the NPDES inspections.
 - (f) Incorporate erosion control into the work in a timely manner and stabilize disturbed areas with mulch/seed or vegetative cover on a section-by-section basis.
 - (g) Use flocculants approved by state regulatory authorities where appropriate and where required for turbidity and sedimentation reduction.

- (h) Ensure proper installation and maintenance of temporary erosion and sediment control devices.
- (i) Remove temporary erosion or sediment control devices when they are no longer necessary as agreed upon by the Engineer.
- (j) The Contractor's quality control and inspection procedures shall be subject to review by the Engineer. Maintain NPDES inspection records and make records available at all times for verification by the Engineer.

(B) *Certified Foreman* - At least one Certified Foreman shall be onsite for each type of work listed herein during the respective construction activities to control erosion, prevent sedimentation and follow permit provisions:

- (1) Foreman in charge of grading activities
- (2) Foreman in charge of bridge or culvert construction over jurisdictional areas
- (3) Foreman in charge of utility activities

The Contractor may request to use the same person as the Level II Supervisor and Level II Foreman. This person shall be onsite whenever construction activities as described above are taking place. This request shall be approved by the Engineer prior to work beginning.

The Contractor may request to name a single Level II Foreman to oversee multiple construction activities on small bridge or culvert replacement projects. This request shall be approved by the Engineer prior to work beginning.

(C) *Certified Installers* - Provide at least one onsite, Level I Certified Installer for each of the following erosion and sediment control/stormwater crew:

- (1) Seeding and Mulching
- (2) Temporary Seeding
- (3) Temporary Mulching
- (4) Sodding
- (5) Silt fence or other perimeter erosion/sediment control device installations
- (6) Erosion control blanket installation
- (7) Hydraulic tackifier installation
- (8) Turbidity curtain installation
- (9) Rock ditch check/sediment dam installation
- (10) Ditch liner/matting installation
- (11) Inlet protection
- (12) Riprap placement
- (13) Stormwater BMP installations (such as but not limited to level spreaders, retention/detention devices)
- (14) Pipe installations within jurisdictional areas

If a Level I *Certified Installer* is not onsite, the Contractor may substitute a Level II Foreman for a Level I Installer, provided the Level II Foreman is not tasked to another crew requiring Level II Foreman oversight.

- (D) *Certified Designer* - Include the certification number of the Level III Certified Designer on the erosion and sediment control/stormwater component of all reclamation plans and if applicable, the certification number of the Level III Certified Designer on the design of the project erosion and sediment control/stormwater plan.

Preconstruction Meeting

Furnish the names of the *Certified Erosion and Sediment Control/Stormwater Supervisor*, *Certified Foremen*, *Certified Installers* and *Certified Designer* and notify the Engineer of changes in certified personnel over the life of the contract within 2 days of change.

Ethical Responsibility

Any company performing work for the North Carolina Department of Transportation has the ethical responsibility to fully disclose any reprimand or dismissal of an employee resulting from improper testing or falsification of records.

Revocation or Suspension of Certification

Upon recommendation of the Chief Engineer to the certification entity, certification for *Supervisor*, *Certified Foremen*, *Certified Installers* and *Certified Designer* may be revoked or suspended with the issuance of an *Immediate Corrective Action (ICA)*, *Notice of Violation (NOV)*, or *Cease and Desist Order* for erosion and sediment control/stormwater related issues.

The Chief Engineer may recommend suspension or permanent revocation of certification due to the following:

- (A) Failure to adequately perform the duties as defined within this certification provision.
- (B) Issuance of an ICA, NOV, or Cease and Desist Order.
- (C) Failure to fully perform environmental commitments as detailed within the permit conditions and specifications.
- (D) Demonstration of erroneous documentation or reporting techniques.
- (E) Cheating or copying another candidate's work on an examination.
- (F) Intentional falsification of records.
- (G) Directing a subordinate under direct or indirect supervision to perform any of the above actions.
- (H) Dismissal from a company for any of the above reasons.
- (I) Suspension or revocation of one's certification by another entity.

Suspension or revocation of a certification will be sent by certified mail to the certificant and the Corporate Head of the company that employs the certificant.

A certificant has the right to appeal any adverse action which results in suspension or permanent revocation of certification by responding, in writing, to the Chief Engineer within 10 calendar days after receiving notice of the proposed adverse action.

Chief Engineer
1536 Mail Service Center
Raleigh, NC 27699-1536

Failure to appeal within 10 calendar days will result in the proposed adverse action becoming effective on the date specified on the certified notice. Failure to appeal within the time specified will result in a waiver of all future appeal rights regarding the adverse action taken. The certificant will not be allowed to perform duties associated with the certification during the appeal process.

The Chief Engineer will hear the appeal and make a decision within 7 days of hearing the appeal. Decision of the Chief Engineer will be final and will be made in writing to the certificant.

If a certification is temporarily suspended, the certificant shall pass any applicable written examination and any proficiency examination, at the conclusion of the specified suspension period, prior to having the certification reinstated.

Measurement and Payment

Certified Erosion and Sediment Control/Stormwater Supervisor, Certified Foremen, Certified Installers and Certified Designer will be incidental to the project for which no direct compensation will be made.

PROCEDURE FOR MONITORING BORROW PIT DISCHARGE:

(2-20-07) (Rev. 4-5-19)

105-16, 230, 801

SP1 G181

Water discharge from borrow pit sites shall not cause surface waters to exceed 50 NTUs (nephelometric turbidity unit) in streams not designated as trout waters and 10 NTUs in streams, lakes or reservoirs designated as trout waters. For lakes and reservoirs not designated as trout waters, the turbidity shall not exceed 25 NTUs. If the turbidity exceeds these levels due to natural background conditions, the existing turbidity level shall not be increased.

If during any operating day, the downstream water quality exceeds the standard, the Contractor shall do all of the following:

- (A) Either cease discharge or modify the discharge volume or turbidity levels to bring the downstream turbidity levels into compliance, or
- (B) Evaluate the upstream conditions to determine if the exceedance of the standard is due to natural background conditions. If the background turbidity measurements exceed the standard, operation of the pit and discharge can continue as long as the stream turbidity levels are not increased due to the discharge.
- (C) Measure and record the turbidity test results (time, date and sampler) at all defined sampling locations 30 minutes after startup and at a minimum, one additional sampling of all sampling locations during that 24-hour period in which the borrow pit is discharging.
- (D) Notify DWQ within 24 hours of any stream turbidity standard exceedances that are not brought into compliance.

During the Environmental Assessment required by Article 230-4 of the *2018 Standard Specifications*, the Contractor shall define the point at which the discharge enters into the State's surface waters and the appropriate sampling locations. Sampling locations shall include points upstream and downstream from the point at which the discharge enters these waters. Upstream sampling location shall be located so that it is not influenced by backwater conditions and represents natural background conditions. Downstream sampling location shall be located at the point where complete mixing of the discharge and receiving water has occurred.

The discharge shall be closely monitored when water from the dewatering activities is introduced into jurisdictional wetlands. Any time visible sedimentation (deposition of sediment) on the wetland surface is observed, the dewatering activity will be suspended until turbidity levels in the stilling basin can be reduced to a level where sediment deposition does not occur. Staining of wetland surfaces from suspended clay particles, occurring after evaporation or infiltration, does not constitute sedimentation. No activities shall occur in wetlands that adversely affect the functioning of a wetland. Visible sedimentation will be considered an indication of possible adverse impacts on wetland use.

The Engineer will perform independent turbidity tests on a random basis. These results will be maintained in a log within the project records. Records will include, at a minimum, turbidity test results, time, date and name of sampler. Should the Department's test results exceed those of the Contractor's test results, an immediate test shall be performed jointly with the results superseding the previous test results of both the Department and the Contractor.

The Contractor shall use the *NCDOT Turbidity Reduction Options for Borrow Pits Matrix*, available at <https://connect.ncdot.gov/resources/roadside/FieldOperationsDocuments/TurbidityReductionOptionSheet.pdf> to plan, design, construct, and maintain BMPs to address water quality standards. Tier I Methods include stilling basins which are standard compensatory BMPs. Other Tier I methods are noncompensatory and shall be used when needed to meet the stream turbidity standards. Tier II Methods are also noncompensatory and are options that may be needed for protection of rare or unique resources or where special environmental conditions exist at the site which have led to additional requirements being placed in the DWQ's 401 Certifications and approval letters, Isolated Wetland Permits, Riparian Buffer Authorization or a DOT Reclamation Plan's Environmental Assessment for the specific site. Should the Contractor exhaust all Tier I Methods on a site exclusive of rare or unique resources or special environmental conditions, Tier II Methods may be required by regulators on a case by case basis per supplemental agreement.

The Contractor may use cation exchange capacity (CEC) values from proposed site borings to plan and develop the bid for the project. CEC values exceeding 15 milliequivalents per 100 grams of soil may indicate a high potential for turbidity and should be avoided when dewatering into surface water is proposed.

No additional compensation for monitoring borrow pit discharge will be paid.

PROJECT SPECIAL PROVISIONS**ROADWAY****SHOULDER RECONSTRUCTION PER SHOULDER MILE:**

(1-18-00) (Rev. 1-17-23)

560, 1019

SPI R07R

Description

The work covered by this provision consists of clipping high shoulders and reconstructing the earth shoulder in accordance with Standard Drawing No. 560.01 and 560.02 of the *Roadway Standard Drawings* with the following exceptions: the width will be shown on typical sections, or to the existing shoulder point, whichever is nearer, as long as the desired typical is achieved. Seeding and mulching shall be performed upon completion of shoulder grading when earth borrow is used.

This work shall be performed immediately after the resurfacing operations are complete as directed by the Engineer.

Materials

The Contractor shall furnish all earth material necessary for the construction of the shoulders in accordance with Section 1019 of the *Standard Specifications*. All soil is subject to test and acceptance or rejection by the Engineer.

The Contractor **is required to use Aggregate Shoulder Borrow (ASB) at all locations with shoulder reconstruction.**

ASB shall meet the following gradation:

<u>Sieve</u>	<u>Percent Passing</u>
1 1/2"	100
1/2"	55 - 95
#4	35 - 74

Construction Methods

Obtain material from within the project limits or approved source. Prior to adding ASB material, the existing shoulder shall be scarified to provide the proper bond and shall be compacted to the satisfaction of the Engineer.

Any excess material generated by the shoulder reconstruction shall be disposed of by the Contractor in an approved disposal site.

Measurement and Payment

Shoulder Reconstruction will be measured and paid as the actual number of miles of shoulders that have been reconstructed and accepted by the Engineer. Measurement will be made along the surface of each shoulder to the nearest 0.01 of a mile. Such price will include disposing of any

excess material in an approved disposal site, and for all labor, tools, equipment, and incidentals necessary to complete the work.

Aggregate Shoulder Borrow will be measured and paid at the contract unit price per ton that has been incorporated into the completed work that is accepted by the Engineer. The number of tons of material is determined by weighing the material in trucks in accordance with Article 106-7. No deductions will be made for any moisture contained in the aggregate at time of weighing.

Incidental Stone Base will be measured and paid as provided in Article 545-6 of the *Standard Specifications*. Where ASB is used, *Incidental Stone Base* will not be required.

Seeding and Mulching will be measured and paid as provided in Article 1660-8 of the *Standard Specifications*.

Where ASB is used, seeding and mulching will not be required.

Payment will be made under:

Pay Item

Shoulder Reconstruction
Aggregate Shoulder Borrow

Pay Unit

Shoulder Mile
Ton

CLEARING AND GRUBBING - METHOD III:

(4-6-06) (Rev.8-18-15)

200

SP2 R02B

Perform clearing on this project to the limits established by Method "III" shown on Standard Drawing No. 200.03 of the *2018 Roadway Standard Drawings*. Conventional clearing methods may be used except where permit drawings or conditions have been included in the proposal which require certain areas to be cleared by hand methods.

BURNING RESTRICTIONS:

(7-1-95)

200, 210, 215

SP2 R05

Open burning is not permitted on any portion of the right-of-way limits established for this project. Do not burn the clearing, grubbing or demolition debris designated for disposal and generated from the project at locations within the project limits, off the project limits or at any waste or borrow sites in this county. Dispose of the clearing, grubbing and demolition debris by means other than burning, according to state or local rules and regulations.

TEMPORARY PAVEMENT WIDENING:

(8-15-00) (Rev. 4-21-15)

1101

SP2 R30A(rev.)

Construct the pavement widening required on this project in accordance with the typical sections in the plans or as directed by the Engineer.

After the widenings have served their purpose, remove the portions deemed unsuitable for use as a permanent part of the project as directed by the Engineer. Place pavement and earth material removed from the widenings in embankments or dispose of in waste areas furnished by the Contractor.

Pipe culverts removed from the widenings remain the property of the Contractor. Pipe culverts that are removed will be measured and will be paid at the contract unit price per linear foot for *Pipe Removal*. Payment for the construction of the widenings will be made at the contract unit prices for the various items involved.

No direct payment will be made for removing the earth material and pavement, as the cost of same shall be included in the lump sum price bid for *Grading*. Such prices and payments will be full compensation for the work of removing and for placing earth material and pavement in embankments or disposing of earth material and pavement in waste areas.

9" CONCRETE TRUCK APRON:

Description

Construct 9" Concrete Truck Apron in accordance with Section 848 of the Standard Specifications and as modified by the typical section in the plans and this provision.

Materials

Concrete shall be Class A Concrete meeting the requirements of Section 1000 of the Standard Specifications.

Wire mesh reinforcement shall be 4x4 - W3.5 x W3.5 or 6x6 - W5 x W5 wire mesh meeting the requirements of Section 1070 of the Standard Specifications.

Construction Methods

Construct concrete apron in accordance with Section 848 of the Standard Specifications. Joints for the 9" Jointed Concrete Truck Apron shall be radial. Expansion joint spacing shall not exceed 60' and contraction joint spacing shall be 1/8" wide and 4" deep not exceeding 15' on centers, measured at the outside edge of the apron, or as directed by the Engineer. Position the welded wire mesh at mid-depth of the slab.

Joints, aligned radially, shall be placed in the concrete. The spacing of these joints shall be 15' or less on top of 4" B25.0C base course.

Measurement and Payment

9" Concrete Truck Apron will be measured and paid for in square yards of 9" Concrete Truck Apron that have completed and accepted. Such price and payment will be full compensation for all work of constructing the truck apron, including but not limited to excavating and backfilling, furnishing and placing concrete, and constructing joints.

Pay Item

9" Concrete Truck Apron

Pay Unit

Square Yard

SHOULDER AND FILL SLOPE MATERIAL:

(5-21-02)

235, 560

SP2 R45 A

Description

Perform the required shoulder and slope construction for this project in accordance with the applicable requirements of Section 560 and Section 235 of the *2018 Standard Specifications*.

Measurement and Payment

Where the material has been obtained from an authorized stockpile or from a borrow source and *Borrow Excavation* is not included in the contract, no direct payment will be made for this work, as the cost of this work will be part of the work being paid at the contract lump sum price for *Grading*. If *Borrow Excavation* is included in this contract and the material has been obtained from an authorized stockpile or from a borrow source, measurement and payment will be as provided in Section 230 of the *2018 Standard Specifications* for *Borrow Excavation*.

MANUFACTURED QUARRY FINES IN EMBANKMENTS:

(01-17-17)

235

SP02 R72(Rev)

Description

This specification addresses the use of manufactured quarry fines that are not classified as select materials. The specification allows the Contractor an option, with the approval of the Engineer, to use manufactured quarry fines (MQFs) in embankments as a substitute for conventional borrow material. Furnish and place geotextile for pavement stabilization in accordance with the Geotextile for Pavement Stabilization special provision and detail. Geotextile for pavement stabilization is required to prevent pavement cracking and provide separation between the subgrade and pavement section at embankment locations where manufactured quarry fines are utilized and as directed by the Engineer.

Materials

Manufactured Quarry Fines.

Site specific approval of MQFs material will be required prior to beginning construction as detailed in the preconstruction requirements of this provision.

The following MQFs are unacceptable:

- (A) Frozen material,
- (B) Material with a maximum dry unit weight of less than 90 pounds per cubic foot when tested in accordance with AASHTO T-99 Method A or C.
- (C) Material with greater than 80% by weight Passing the #200 sieve

Collect and transport MQFs in a manner that will prevent nuisances and hazards to public health and safety. Moisture condition the MQFs as needed and transport in covered trucks to prevent dusting. If MQFs are blended with natural earth material, follow Borrow Criteria in Section 1018 of the *Standard Specifications*.

Geotextiles

Areas of embankment where MQFs are incorporated, Geotextile for Pavement Stabilization shall be used. If the Geotextile for Pavement Stabilization special provision is not included elsewhere in this contract, then it along with a detail will be incorporated as part of the contractors request to

use. Notification of subgrade elevation, sampling and waiting period as required in the Construction Methods section of the Geotextile for Pavement Stabilization special provision are not required.

Preconstruction Requirements

When MQFs are to be used as a substitute for earth borrow material, request written approval from the Engineer at least ninety (90) days in advance of the intent to use MQFs and include the following details:

- (A) Description, purpose and location of project.
- (B) Estimated start and completion dates of project.
- (C) Estimated volume of MQFs to be used on project with specific locations and construction details of the placement.
- (D) The names, address, and contact information for the generator of the MQFs.
- (E) Physical location of the site at which the MQFs were generated.

The Engineer will forward this information to the State Materials Engineer for review and material approval.

Construction Methods

Place MQFs in the core of the embankment section with at least 4 feet of earth cover to the outside limits of the embankments or subgrade.

Construct embankments by placing MQFs in level uniform lifts with no more than a lift of 10 inches and compacted to at least a density of 95 percent as determined by test methods in AASHTO T-99, Determination of Maximum Dry Density and Optimum Moisture Content, Method A or C depending upon particle size of the product. Provide a moisture content at the time of compaction of within 4 percent of optimum but not greater than one percent above optimum as determined by AASHTO T-99, Method A or C.

Areas of embankment where MQFs are incorporated, Geotextile for Pavement Stabilization shall be used. See Geotextile for Pavement Stabilization special provision for geotextile type and construction method.

Measurement and Payment

Borrow Excavation will be measured by truck volume and paid in cubic yards in accordance with Article 230-5 of the *2018 Standard Specifications*. As an alternate weigh tickets can be provided and payment made by converting weight to cubic yards based on the verifiable unit weight. Where the pay item for *Borrow Excavation* is not included in the original contract then no separate payment will be made for this item and payment will be included in the lump sum price bid for *Grading*.

Where the pay item of *Geotextile for Pavement Stabilization* is included in the original contract the material will be measured and paid in square yards (see Geotextile for Pavement Stabilization special provision). Where the pay item of *Geotextile for Pavement Stabilization* is not included in

the original contract then no payment will be made for this item and will be considered incidental to the use of MQFs in embankment.

FLOWABLE FILL:

(9-17-02) (Rev 1-17-12)

300, 340, 1000, 1530, 1540, 1550

SP3 R30

Description

This work consists of all work necessary to place flowable fill in accordance with these provisions, the plans, and as directed.

Materials

Refer to Division 10 of the *2018 Standard Specifications*.

Item

Flowable Fill

Section

1000-6

Construction Methods

Discharge flowable fill material directly from the truck into the space to be filled, or by other approved methods. The mix may be placed full depth or in lifts as site conditions dictate. The Contractor shall provide a method to plug the ends of the existing pipe in order to contain the flowable fill.

Measurement and Payment

At locations where flowable fill is called for on the plans and a pay item for flowable fill is included in the contract, *Flowable Fill* will be measured in cubic yards and paid as the actual number of cubic yards that have been satisfactorily placed and accepted. Such price and payment will be full compensation for all work covered by this provision including, but not limited to, the mix design, furnishing, hauling, placing and containing the flowable fill.

Payment will be made under:

Pay Item

Flowable Fill

Pay Unit

Cubic Yard

CORRUGATED ALUMINUM ALLOY CULVERT PIPE:

(9-21-21)

305, 310

SP3 R34

Revise the *Standard Specifications* as follows:

Page 3-5, Article 305-2, MATERIALS, add the following after line 16:

Item

Waterborne Paint

Hot Bitumen

Section

1080-9

1081-3

Page 3-5, Article 305-3, CONSTRUCTION METHODS, add the following after line 24:

Coating must be applied to the aluminum when in contact with concrete. Immediately prior to coating, aluminum surfaces to be coated shall be cleaned by a method that will remove all dirt, oil, grease, chips, and other foreign substances. Aluminum to be coated shall be given one coat of suitable quality coating such as:

Approved waterborne paint (Section 1080-9)
Approved Hot Bitumen (Section 1081-3)

Other coating materials may be submitted to the Engineer for approval.

Page 3-7, Article 310-6, MEASUREMENT AND PAYMENT, lines 6-11, delete the fourth sentence and replace with the following:

Select bedding and backfill material and coating will be included in the cost of the installed pipe. Such price and payment will be full compensation for all materials, labor, equipment, and other incidentals necessary to complete the work.

CULVERT PIPE:

(8-20-19)(Rev. 5-17-22)

305,310

SP3 R35

Revise the *2018 Standard Specifications* as follows:

Page 3-5, Article 305-1 DESCRIPTION, lines 12-14, replace with the following:

Where shown in the plans, the Contractor may use reinforced concrete pipe, aluminum alloy pipe, aluminized corrugated steel pipe, galvanized corrugated steel pipe, HDPE pipe, Polypropylene pipe or PVC pipe in accordance with the following requirements.

Page 3-5, Article 305-2 MATERIALS, add the following after line 16:

Item	Section
Polypropylene Pipe	1032-9
Galvanized Corrugated Steel Pipe	1032-3

Page 3-6, Article 310-2 MATERIALS, add the following after line 9:

Item	Section
Polypropylene Pipe	1032-9
Galvanized Corrugated Steel Pipe	1032-3

Page 3-6, Article 310-4 SIDE DRAIN PIPE, lines 24-25, replace the first sentence of the second paragraph with the following:

Where shown in the plans, side drain pipe may be Class II reinforced concrete pipe, aluminized corrugated steel pipe, galvanized corrugated steel pipe, corrugated aluminum alloy pipe, Polypropylene pipe, HDPE pipe or PVC pipe.

Page 3-7, Article 310-5 PIPE END SECTIONS, lines 2-4, replace the second sentence with the

following:

Both corrugated steel and concrete pipe end sections will work on concrete pipe, corrugated steel pipe, Polypropylene pipe and HDPE smooth lined corrugated plastic pipe.

Page 3-7, Article 310-6 MEASUREMENT AND PAYMENT, add the following after line 14:

Pay Item	Pay Unit
__" Polypropylene Pipe	Linear Foot

Page 10-60, add Article 1032-9:

(A) General

Use polypropylene pipe from sources participating in the Department's Polypropylene Pipe QA/QC Program. A list of participating sources is available from the Materials and Tests Unit. The Department will remove a manufacturer of polypropylene pipe from this program if the monitoring efforts indicated that non-specification material is being provided or test procedures are not being followed.

Use polypropylene culvert pipe that meets AASHTO M 330 for Type S or Type D, or ASTM F2881 or ASTM F2764 Double or Triple wall; and has been evaluated by NTPEP.

(B) End Treatments, Pipe Tees and Elbows

End treatments, pipe tees and elbows shall meet AASHTO M 330, Section 7.7, or ASTM F2764, Section 6.6.

(C) Marking

Clearly mark each section of pipe, end section, tee and elbow and other accessories according to the Department's Polypropylene Pipe QC/QA Program:

- (1) AASHTO or ASTM Designation
- (2) The date of manufacture
- (3) Name or trademark of the manufacturer

When polypropylene pipe, end sections, tees and elbows have been inspected and accepted a sticker will be applied to the inside of the pipe. Do not use pipe sections, flared end sections, tees or elbows which do not have this seal of approval.

BRIDGE APPROACH FILLS:

(10-19-10) (Rev. 1-16-18)

422

SP4 R02A

Description

Bridge approach fills consist of backfilling behind bridge end bents with select material or aggregate to support all or portions of bridge approach slabs. Install drains to drain water from bridge approach fills and geotextiles to separate approach fills from embankment fills, ABC and natural ground as required. For bridge approach fills behind end bents with mechanically stabilized earth (MSE) abutment walls, reinforce bridge approach fills with MSE wall reinforcement connected to end bent caps. Construct bridge approach fills in accordance with the contract, accepted submittals and 2018 Roadway Standard Drawing Nos. 422.01 or 422.02 or Roadway Detail Drawing No. 422D10.

Define bridge approach fill types as follows:

Approach Fills – Bridge approach fills in accordance with 2018 Roadway Standard Drawing Nos. 422.01 or 422.02 or Roadway Detail Drawing No. 422D10;

Standard Approach Fill – Type I Standard Bridge Approach Fill in accordance with 2018 Roadway Standard Drawing No. 422.01;

Modified Approach Fill – Type II Modified Bridge Approach Fill in accordance with 2018 Roadway Standard Drawing No. 422.02 and

Reinforced Approach Fill – Type III Reinforced Bridge Approach Fill in accordance with Roadway Detail Drawing No. 422D10.

Materials

Refer to Division 10 of the *2018 Standard Specifications*.

Item	Section
Geotextiles, Type 1	1056
Portland Cement Concrete	1000
Select Materials	1016
Subsurface Drainage Materials	1044

Provide Type 1 geotextile for separation geotextiles and Class B concrete for outlet pads. Use Class V or Class VI select material for standard and modified approach fills. For an approach fill behind a bridge end bent with an MSE abutment wall, backfill the reinforced approach fill with the same aggregate type approved for the reinforced zone in the accepted MSE wall submittal. For MSE wall aggregate, reinforcement and connector materials, see the *Mechanically Stabilized Earth Retaining Walls* provision. Provide PVC pipes, fittings and outlet pipes for subsurface drainage materials. For PVC drain pipes, use pipes with perforations that meet AASHTO M 278.

Construction Methods

Excavate as necessary for approach fills in accordance with the contract. Notify the Engineer when foundation excavation is complete. Do not place separation geotextiles or aggregate until approach fill dimensions and foundation material are approved.

For reinforced approach fills, cast MSE wall reinforcement or connectors into end bent cap backwalls within 3" of locations shown in the accepted MSE wall submittals. Install MSE wall reinforcement with the orientation, dimensions and number of layers shown in the accepted MSE wall submittals. If a reinforced approach fill is designed with geogrid reinforcement embedded in an end bent cap, cut geogrids to the required lengths and after securing ends of geogrids in place, reroll and rewrap portions of geogrids not embedded in the cap to protect geogrids from damage. Before placing aggregate, pull geosynthetic reinforcement taut so that it is in tension and free of kinks, folds, wrinkles or creases.

Attach separation geotextiles to end bent cap backwalls and wing walls with adhesives, tapes or other approved methods. Overlap adjacent separation geotextiles at least 18" with seams oriented parallel to the roadway centerline. Hold geotextiles in place with wire staples or anchor pins as needed. Contact the Engineer when existing or future obstructions such as foundations, pavements, pipes, inlets or utilities will interfere with separation geotextiles or MSE wall reinforcement.

Install continuous perforated PVC drain pipes with perforations pointing down in accordance with 2018 Roadway Standard Drawing Nos. 422.01 or 422.02. Connect drain pipes to outlet pipes just beyond wing walls. Connect PVC pipes, fittings and outlet pipes with solvent cement in accordance with Article 815-3 of the *2018 Standard Specifications* and place outlet pads in accordance with 2018 Roadway Standard Drawing No. 815.03.

Install drain pipes so water drains towards outlets. If the groundwater elevation is above drain pipe elevations, raise drains up to maintain positive drainage towards outlets. Place pipe sleeves in or under wing walls so water drains towards outlets. Use sleeves that can withstand wing wall loads.

Place select material or aggregate in 8" to 10" thick lifts. Compact fine aggregate for reinforced approach fills in accordance with Subarticle 235-3(C) of the *2018 Standard Specifications* except compact fine aggregate to a density of at least 98%. Compact select material for standard or modified approach fills and coarse aggregate for reinforced approach fills with a vibratory compactor to the satisfaction of the Engineer. Do not displace or damage geosynthetics, MSE wall reinforcement or drains when placing and compacting select material or aggregate. End dumping directly on geosynthetics is not permitted. Do not operate heavy equipment on geosynthetics or drain pipes until they are covered with at least 8" of select material or aggregate. Replace any damaged geosynthetics or drains to the satisfaction of the Engineer. When approach fills extend beyond bridge approach slabs, wrap separation geotextiles over select material or aggregate as shown in 2018 Roadway Standard Drawing No. 422.01 or 2018 Roadway Detail Drawing No. 422D10.

Measurement and Payment

Type I Standard Approach Fill, Station _____, Type II Modified Approach Fill, Station _____ and Type III Reinforced Approach Fill, Station _____ will be paid at the contract lump sum price. The lump sum price for each approach fill will be full compensation for providing labor, tools, equipment and approach fill materials, excavating, backfilling, hauling and removing excavated materials, installing geotextiles and drains, compacting backfill and supplying select material, aggregate, separation geotextiles, drain pipes, pipe sleeves, outlet pipes and pads and any incidentals necessary to construct approach fills behind bridge end bents.

The contract lump sum price for *Type III Reinforced Approach Fill, Station _____* will also be full compensation for supplying and connecting MSE wall reinforcement to end bent caps but not designing MSE wall reinforcement and connectors. The cost of designing reinforcement and connectors for reinforced approach fills behind bridge end bents with MSE abutment walls will be incidental to the contract unit price for *MSE Retaining Wall No. _____*.

Payment will be made under:

Pay Item

Type I Standard Approach Fill, Station _____
 Type II Modified Approach Fill, Station _____
 Type III Reinforced Approach Fill, Station _____

Pay Unit

Lump Sum
 Lump Sum
 Lump Sum

BRIDGE APPROACH FILLS – GEOTEXTILE:

(5-17-22)

SP4 R03

Place a single layer of Type 5 Geotextile one foot below the approach slab for the full width and length of the approach fill. Type 5 Geotextile shall meet the requirements of Section 1056 of the *Standard Specifications*. This revision applies to Roadway Standard 422.01, 422.02, 422.03 and Detail in Lieu of Standard 422DO10.

No separate measurement or payment will be made for the work required by this provision as the cost of such work shall be included in the lump sum price bid for *Type I Standard Approach Fill Station _____, Type III Reinforced Approach Fill, Station _____ or Type II Modified Approach Fill, Station _____*.

AGGREGATE SUBGRADE:

(5-15-18)(Rev. 4-18-23)

505

SP5 R8

Revise the *2018 Standard Specifications* as follows:

Page 5-8, Section 505 AGGREGATE SUBGRADE, lines 3-32, replace the section with the following:

505-1 DESCRIPTION

Construct aggregate subgrades in accordance with the contract. Install geotextile for subgrade stabilization and place Class IV subgrade stabilization at locations shown in the plans and as directed by the Engineer.

Undercut natural soil materials if necessary to construct aggregate subgrades. Define “subsoil” as the portion of the roadbed below the Class IV subgrade stabilization. For Type 2 aggregate subgrades, undercut subsoil as needed. The types of aggregate subgrade with thickness and compaction requirements for each are as shown below.

Type 1 – A 6 to 24 inch thick aggregate subgrade with Class IV subgrade stabilization compacted to 92% of AASHTO T 180 as modified by the Department or to the highest density that can be reasonably obtained.

Type 2 – An 8 inch thick aggregate subgrade on a proof rolled subsoil with Class IV subgrade stabilization compacted to 97% of AASHTO T 180 as modified by the Department.

505-2 MATERIALS

Refer to Division 10.

Item	Section
Geotextile for Subgrade Stabilization, Type 5	1056
Select Material, Class IV	1016

Use Class IV select material for Class IV subgrade stabilization.

505-3 CONSTRUCTION METHODS

When shallow undercut is required to construct aggregate subgrades, undercut 6 inches to 24 inches as shown on the plans or as directed by the Engineer. For Type 2 aggregate subgrades, proof roll subsoil in accordance with Section 260 before installing geotextile for subgrade stabilization. Perform undercut excavation in accordance with Section 225.

Do not leave geotextiles exposed for more than 7 days before covering geotextiles with Class IV subgrade stabilization (standard size no. ABC). Install geotextile for subgrade stabilization on subsoil with the long dimension, i.e., machine direction (MD), of the roll parallel to the roadway centerline and completely cover subsoil with geotextiles. For fill sections, the minimum roll width is required under roadway edges and shoulders nearest to fill slopes as shown in the plans. Overlap adjacent geotextiles at least 18 inches in the direction that ABC will be placed to prevent lifting the edge of the top geotextile. Pull geotextiles taut so they are in tension and free of kinks, folds, wrinkles or creases. Hold geotextiles in place as needed with wire staples or anchor pins.

Place Class IV subgrade stabilization by end dumping ABC on geotextiles. Do not operate heavy equipment on geotextiles until geotextiles are covered with Class IV subgrade stabilization. Compact ABC as required for the type of aggregate subgrade constructed.

Maintain Class IV subgrade stabilization in an acceptable condition and minimize the use of heavy equipment on ABC in order to avoid damaging aggregate subgrades. Provide and maintain drainage ditches and drains as required to prevent entrapping water in aggregate subgrades.

505-4 MEASUREMENT AND PAYMENT

Shallow Undercut of natural soil materials from subsoil for Type 1 aggregate subgrades will be measured and paid in cubic yards, measured in the original position and computed by the average end area method that is acceptably excavated in accordance with the contract. The contract unit price for *Shallow Undercut* will be full compensation for excavating, hauling and disposing of materials to construct aggregate subgrades.

Undercut Excavation of natural soil materials from subsoil for Type 2 aggregate subgrades will be measured and paid in accordance with Article 225-7 or 226-3. No measurement will be made for any undercut excavation of fill materials from subsoil.

Class IV Subgrade Stabilization will be measured and paid in tons. Class IV subgrade stabilization will be measured by weighing material in trucks in accordance with Article 106-7. The contract unit price for *Class IV Subgrade Stabilization* will be full compensation for furnishing, hauling, handling, placing, compacting and maintaining ABC.

Geotextile for Subgrade Stabilization will be measured and paid in square yards. Geotextiles will be measured along the ground surface as the square yards of exposed geotextiles before placing ABC. No measurement will be made for overlapping geotextiles. The contract unit price for *Geotextile for Subgrade Stabilization* will be full compensation for providing, transporting and installing geotextiles, wire staples and anchor pins.

Payment will be made under:

Pay Item	Pay Unit
Shallow Undercut	Cubic Yard
Class IV Subgrade Stabilization	Ton
Geotextile for Subgrade Stabilization	Square Yard

INCIDENTAL MILLING:

(11-15-22)(Rev. 1-17-23)

607

SP6 R02R

Revise the *2018 Standard Specifications* as follows:

Page 6-5, Article 607-3 CONSTRUCTION METHODS, add the following paragraph after line 45:

Variable depth milling is intended to improve the cross-sectional slope of the pavement.

Page 6-6, Article 607-3 CONSTRUCTION METHODS, line 9, delete and replace the first sentence in the sixth paragraph with the following:

The Engineer may require re-milling of any area exhibiting pavement laminations, scabbing or other defects.

Page 6-6, Article 607-4 TOLERANCE, lines 17-18, delete and replace the second sentence with

the following:

The Engineer may vary the depth of milling by not more than one inch. In the event the directed depth of milling cut is altered by the Engineer more than one inch, either the Department or the Contractor may request an adjustment in unit price in accordance with Article 104-3. In administering Article 104-3, the Department will give no consideration to value given to RAP due to the deletion or reduction in quantity of milling. Article 104-3 will not apply to the item of *Incidental Milling*.

Page 6-6, Subarticle 607-5(A) Milled Asphalt Pavement, lines 21-23, delete and replace the first sentence with the following:

Milled Asphalt Pavement, __" Depth will be measured and paid as the actual number of square yards of pavement surface milled in accordance with this specification.

Page 6-6, Subarticle 607-5(A) Milled Asphalt Pavement, lines 24-28, delete and replace the third and fourth sentence with the following:

The width will be the width required by the plans or directed by the Engineer, measured along the pavement surface. Areas to be paid under this item include mainline travel lanes, full width turn lanes greater than 500 feet in length, collector lanes, shoulders, and any additional equipment necessary to remove pavement in the area of manholes, water valves, curb, gutter and other obstructions.

Page 6-6, Subarticle 607-5(B) Milled Asphalt Pavement Depth Varies from Required Depth, lines 29-37, delete and replace the title and first paragraph with the following:

(B) Variable Depth Milled Asphalt Pavement

Milling Asphalt Pavement, __" to __" will be measured and paid as the actual number of square yards of pavement surface milled in accordance with this specification. In measuring this quantity, the length will be the actual length milled, measured along the pavement surface. The width will be the width required by the plans or directed by the Engineer, measured along the pavement surface. Areas to be paid under this item include mainline travel lanes, full width turn lanes greater than 500 feet in length, collector lanes, shoulders, and any additional equipment necessary to remove pavement in the area of manholes, water valves, curb, gutter and other obstructions.

Page 6-6, Subarticle 607-5(C) Incidental Milling, lines 45-49, delete and replace the first and second sentence with the following:

Incidental Milling will be measured and paid as the actual number of square yards of surface milled where the Contractor is required to mill butt joints, irregular areas, full width turn lanes 500 feet or less, intersections and re-mill areas that are not due to the Contractor's negligence. In measuring this quantity, the length will be the actual length milled, measured along the pavement surface. The width will be the width required by the plans or directed by the Engineer, measured along the pavement surface.

Page 6-7, Subarticle 607-5(D) Milling of Defects, lines 6-10, delete and replace the second sentence with the following:

If the Engineer directs re-milling of an area and is not due to the Contractor's negligence, the re-milled area will be measured as provided in Subarticle 607-5(C) and paid at the contract unit price per square yard for *Incidental Milling*.

FINE MILLING:

(8-9-13)

607

SPI 6-17

Description

This work includes fine milling of existing asphalt concrete pavement to remove the existing Ultra-thin Bonded Wearing Course as indicated in the Plans and as directed by the Engineer. The fine milled surface shall provide a texture suitable for use as a temporary riding surface and an immediate overlay with Ultra-thin Bonded Wearing Course with no further treatment or overlays.

Construction Method

(A) Equipment

Use power-driven, self-propelled fine-milling equipment possessing the size and shape to allow traffic safe passage through areas adjacent to the work. Also, ensure the fine-milling equipment will be:

- (1) Equipped with a cutting mandrel with carbide or equivalent tipped cutting teeth designed for fine-milling (5/16 inch spacing) bituminous pavement full lane width to close tolerances.
- (2) Equipped with grade and slope controls operating from a string line or ski and based on mechanical or sonic operation.
- (3) Capable of removing pavement to an accuracy of 3/8 in.
- (4) Furnished with a lighting system for night work, as necessary.
- (5) Provided with conveyors capable of side, rear, or front loading to transfer the milled material from the roadway to a truck.

(B) Fine Milling Operation

Follow the Plans to fine-mill the designated areas and depths, as required. Ensure the following requirements are met:

- (1) Ensure fine-milling methods produce a uniform finished surface and maintain a constant cross slope between extremities in each lane.
- (2) Provide positive drainage to prevent water accumulation on the fine-milled pavement, as shown on the Plans or directed by the Engineer.
- (3) Bevel back the longitudinal vertical edges greater than 2 inch produced by the removal process and left exposed to traffic. Bevel the vertical edges back at least 3 inch for each 2 inch of material removed. Use an attached mold board or other approved method.

- (4) Taper the transverse edges 10 feet to avoid creating a traffic hazard and to produce a smooth surface when removing material at ramp areas and ends of milled sections.
- (5) Protect with a temporary asphaltic concrete tie-in (paper joint) vertical edges at other areas such as bridge approach slabs, drainage structures, and utility appurtenances greater than 1/2 inch areas left open to transversing vehicles. Place the temporary tie-in at taper rate of at least 6 to 1 horizontal to vertical distance.
- (6) Remove dust, residue, and loose milled material from the fine-milled surface. Do not allow traffic on the milled surface and do not place asphaltic concrete on the milled surface until removal is complete.

(C) Quality Acceptance

Provide a fine-milled test section of a minimum of 400 feet in length for approval by the Engineer to ensure the fine milling operation provides a surface texture suitable as a temporary riding surface using a fine milling drum with adequate bit spacing and wrap configuration and proper forward cutting speed.

Ensure the fine-milling operation produces a uniform pavement texture true to line, grade, and cross section.

Fine-mill additional depth to eliminate excessive scabbing of the in place material as directed by the Engineer.

Fine-milled pavement surfaces are subject to visual and straightedge inspections. Ensure a 10 ft. straightedge is kept at the fine-milling operation to measure surface irregularities of the milled pavement surface.

Ensure the cross slope is uniform and no depressions or slope misalignments greater than 1/4 inch per 12 foot exist when the slope is tested with a straightedge placed perpendicular to the center line.

Measurement and Payment

Fine Milling will be measured and paid as the actual number of square yards of pavement surface milled in accordance with this Specification. In measuring this quantity, the length will be the actual length milled, measured along the pavement surface. The width will be the width required by the plans or directed, measured along the pavement surface. Such price and payment will be full compensation for furnishing equipment, fine-milling, hauling, stockpiling milled material, and satisfactorily performing the work.

Payment will be made under:

Pay Item
Fine Milling

Pay Unit
Square Yard

PRICE ADJUSTMENT - ASPHALT BINDER FOR PLANT MIX:

(11-21-00)

620

SP6 R25

Price adjustments for asphalt binder for plant mix will be made in accordance with Section 620 of the *2018 Standard Specifications*.

The base price index for asphalt binder for plant mix is \$ **639.38** per ton.

This base price index represents an average of F.O.B. selling prices of asphalt binder at supplier's terminals on **May 1, 2023**.

FINAL SURFACE TESTING NOT REQUIRED:

(5-18-04) (Rev. 2-16-16)

610

SP6 R45

Final surface testing is not required on this project in accordance with Section 610-13, *Final Surface Testing and Acceptance*.

MILLING ASPHALT PAVEMENT:

(1-15-19)

607

SP6 R59

Revise the *2018 Standard Specifications* as follows:

Page 6-5, Article 607-2, EQUIPMENT, lines 14-16, delete the seventh sentence of this Article and replace with the following:

Use either a non-contacting laser or sonar type ski system with a minimum of three referencing stations mounted on the milling machine at a length of at least 24 feet.

ULTRA-THIN BONDED WEARING COURSE:

(1-15-19)

661

SP6 R64

Revise the *2018 Standard Specifications* as follows:

Page 6-49, Article 661-4, CONSTRUCTION METHODS, lines 25-28, delete the third sentence of this Sub-article and replace with the following:

Unless otherwise specified, use a mobile grade reference system capable of averaging the existing grade or pavement profile over at least a 30 feet distance; or by non-contacting laser or sonar type ski with at least three referencing stations mounted on the paver at a minimum length of 24 feet.

Page 6-50, Article 661-4, CONSTRUCTION METHODS, line 9, delete the word “four” and replace with “three”.

ASPHALT CONCRETE PLANT MIX PAVEMENTS:

(2-20-18) (Rev. 6-20-23)

610, 1012

SP6 R65

Revise the *2018 Standard Specifications* as follows:

Page 6-14, Table 609-3, LIMITS OF PRECISION FOR TEST RESULTS, replace with the following:

Mix Property	Limits of Precision
25.0 mm sieve (Base Mix)	± 10.0%
19.0 mm sieve (Base Mix)	± 10.0%
12.5 mm sieve (Intermediate & Type P-57)	± 6.0%
9.5 mm sieve (Surface Mix)	± 5.0%
4.75 mm sieve (Surface Mix)	± 5.0%
2.36 mm sieve (All Mixes, except S4.75A)	± 5.0%
1.18 mm sieve (S4.75A)	± 5.0%
0.075 mm sieve (All Mixes)	± 2.0%
Asphalt Binder Content	± 0.5%
Maximum Specific Gravity (G_{mm})	± 0.020
Bulk Specific Gravity (G_{mb})	± 0.030
TSR	± 15.0%
QA retest of prepared QC Gyratory Compacted Volumetric Specimens	± 0.015
Retest of QC Core Sample	± 1.2% (% Compaction)
Comparison QA Core Sample	± 2.0% (% Compaction)
QA Verification Core Sample	± 2.0% (% Compaction)
Density Gauge Comparison of QC Test	± 2.0% (% Compaction)
QA Density Gauge Verification Test	± 2.0% (% Compaction)

Page 6-17, Table 610-1, MIXING TEMPERATURE AT THE ASPHALT PLANT, replace with the following:

Binder Grade	JMF Temperature
PG 58-28; PG 64-22	250 - 290°F
PG 76-22	300 - 325°F

Page 6-17, Subarticle 610-3(C), Job Mix Formula (JMF), lines 38-39, delete the fourth paragraph.

Page 6-18, Subarticle 610-3(C), Job Mix Formula (JMF), line 12, replace “SF9.5A” with “S9.5B”.

Page 6-18, Table 610-3, MIX DESIGN CRITERIA, replace with the following:

Mix Type	Design ESALs millions ^A	Binder PG Grade	Compaction Levels		Max. Rut Depth (mm)	Volumetric Properties ^B			
			G _{mm} @			VMA	VTM	VFA	%G _{mm}
			N _{ini}	N _{des}		% Min.	%	Min.-Max.	@ N _{ini}
S4.75A	< 1	64 - 22	6	50	11.5	16.0	4.0 - 6.0	65 - 80	≤ 91.5
S9.5B	0 - 3	64 - 22	6	50	9.5	16.0	3.0 - 5.0	70 - 80	≤ 91.5

S9.5C	3 - 30	64 - 22	7	65	6.5	15.5	3.0 - 5.0	65 - 78	≤ 90.5
S9.5D	> 30	76 - 22	8	100	4.5	15.5	3.0 - 5.0	65 - 78	≤ 90.0
I19.0C	ALL	64 - 22	7	65	-	13.5	3.0 - 5.0	65 - 78	≤ 90.5
B25.0C	ALL	64 - 22	7	65	-	12.5	3.0 - 5.0	65 - 78	≤ 90.5
Design Parameter						Design Criteria			
All Mix Types	Dust to Binder Ratio ($P_{0.075} / P_{bc}$)					0.6 - 1.4 ^C			
	Tensile Strength Ratio (TSR) ^D					85% Min. ^E			

- A. Based on 20 year design traffic.
- B. Volumetric Properties based on specimens compacted to N_{des} as modified by the Department.
- C. Dust to Binder Ratio ($P_{0.075} / P_{bc}$) for Type S4.75A is 1.0 - 2.0.
- D. NCDOT-T-283 (No Freeze-Thaw cycle required).
- E. TSR for Type S4.75A & B25.0C mixes is 80% minimum.

Page 6-19, Table 610-5, BINDER GRADE REQUIREMENTS (BASED ON RBR%), replace with the following:

**TABLE 610-5
BINDER GRADE REQUIREMENTS (BASED ON RBR%)**

Mix Type	%RBR ≤ 20%	21% ≤ %RBR ≤ 30%	%RBR ≥ 30%
S4.75A, S9.5B, S9.5C, I19.0C, B25.0C	PG 64-22	PG 64-22 ^A	PG-58-28
S9.5D, OGFC	PG 76-22 ^B	n/a	n/a

- A. If the mix contains any amount of RAS, the virgin binder shall be PG 58-28.
- B. Maximum Recycled Binder Replacement (%RBR) is 18% for mixes using PG 76-22 binder.

Page 6-20, Table 610-6, PLACEMENT TEMPERATURES FOR ASPHALT, replace with the following:

TABLE 610-6 PLACEMENT TEMPERATURES FOR ASPHALT	
Asphalt Concrete Mix Type	Minimum Surface and Air Temperature
B25.0C	35°F
I19.0C	35°F
S4.75A, S9.5B, S9.5C	40°F ^A
S9.5D	50°F

- A. For the final layer of surface mixes containing recycled asphalt shingles (RAS), the minimum surface and air temperature shall be 50°F.

Page 6-21, Article 610-8, SPREADING AND FINISHING, lines 34-35, delete the second sentence and replace with the following:

Use an MTV for all surface mix regardless of binder grade on Interstate, US Routes, and NC Routes (primary routes) that have 4 or more lanes and median divided.

Page 6-21, Article 610-8, SPREADING AND FINISHING, lines 36-38, delete the fourth sentence and replace with the following:

Use MTV for all ramps, loops, Y-line that have 4 or more lanes and are median divided, full width acceleration lanes, full width deceleration lanes, and full width turn lanes that are greater than 1000 feet in length.

Page 6-23, Table 610-7, DENSITY REQUIREMENTS, replace with the following:

TABLE 610-7 DENSITY REQUIREMENTS	
Mix Type	Minimum % G_{mm} (Maximum Specific Gravity)
S4.75A	85.0 ^A
S9.5B	90.0
S9.5C, S9.5D, I19.0C, B25.0C	92.0

- A. Compaction to the above specified density will be required when the S4.75A mix is applied at a rate of 100 lbs/sy or higher.

Page 6-24, Article 610-13, FINAL SURFACE TESTING, lines 35-36, delete the second sentence and replace with the following:

Final surface testing is not required on ramps, loops and turn lanes.

Page 6-26, Subarticle 610-13(A)(1), Acceptance for New Construction, lines 29-30, delete the second sentence and replace with the following:

Areas excluded from testing by the profiler may be tested using a 10-foot straightedge in accordance with Article 610-12.

Page 6-27, Subarticle 610-13(B), Option 2- North Carolina Hearne Straightedge, lines 41-46, delete the eighth and ninth sentence of this paragraph and replace with the following:

Take profiles over the entire length of the final surface travel lane pavement exclusive of structures, approach slabs, paved shoulders, tapers, or other irregular shaped areas of pavement, unless otherwise approved by the Engineer. Test in accordance with this provision all mainline travel lanes, full width acceleration or deceleration lanes and collector lanes.

Page 6-28, Subarticle 610-13(B), Option 2- North Carolina Hearne Straightedge, lines 1-2, delete these two lines.

Page 6-32, Article 610-16 MEASUREMENT AND PAYMENT, replace with the following:

Pay Item	Pay Unit
Asphalt Concrete Base Course, Type B25.0C	Ton
Asphalt Concrete Intermediate Course, Type I19.0C	Ton
Asphalt Concrete Surface Course, Type S4.75A	Ton
Asphalt Concrete Surface Course, Type S9.5B	Ton
Asphalt Concrete Surface Course, Type S9.5C	Ton
Asphalt Concrete Surface Course, Type S9.5D	Ton

Page 10-30, Table 1012-1, AGGREGATE CONSENSUS PROPERTIES, replace with the following:

**TABLE 1012-1
AGGREGATE CONSENSUS PROPERTIES^A**

Mix Type	Coarse Aggregate Angularity ^B	Fine Aggregate Angularity % Minimum	Sand Equivalent % Minimum	Flat and Elongated 5 : 1 Ratio % Maximum
<i>Test Method</i>	<i>ASTM D5821</i>	<i>AASHTO T 304</i>	<i>AASHTO T 176</i>	<i>ASTM D4791</i>
S4.75A; S9.5B	75 / -	40	40	-
S9.5C; I19.0C; B25.0C	95 / 90	45	45	10
S9.5D	100 / 100	45	50	10
OGFC	100 / 100	45	45	10
UBWC	100 / 85	45	45	10

A. Requirements apply to the design aggregate blend.

B. 95 / 90 denotes that 95% of the coarse aggregate has one fractured face and 90% has 2 or more fractured faces.

Page 10-30, Subarticle 1012-1(B)(6), Toughness (Resistance to Abrasion) , line 12, replace “OGAFC” with “OGFC”.

SUPPLEMENTAL SURVEYING:

(4-20-21)

801

SP8 R03

Revise the *2018 Standard Specifications* as follows:

Page 8-7, Article 801-3 MEASUREMENT AND PAYMENT, lines 10-11, replace with the following:

Supplemental Surveying Office Calculations will be paid at the stated price of \$85.00 per hour. *Supplemental Field Surveying* will be paid at the stated price of \$145.00 per hour. The

GUARDRAIL END UNITS & TEMPORARY GUARDRAIL END UNITS, TYPE - TL-2:

(10-21-08) (Rev. 5-16-23)

862

SP8 R64

Description

Furnish and install guardrail end units in accordance with the details in the plans, the applicable requirements of Section 862 of the *Standard Specifications*, and at locations shown in the plans.

Materials

Furnish guardrail end units listed on the NCDOT APL. Units shall not be modified by the manufacturer and installer once approved and on the NCDOT APL.

Prior to installation the Contractor shall submit to the Engineer certified working drawings and assembling instructions from the manufacturer for each guardrail end unit in accordance with Article 105-2 of the *Standard Specifications*.

Perform installation in accordance with the details in the plans, and details and assembling instructions furnished by the manufacturer.

Construction Methods

Guardrail end delineation is required on all approach and trailing end sections for both temporary and permanent installations. Guardrail end delineation consists of yellow reflective sheeting applied to the entire end section of the guardrail in accordance with Article 1088-3 of the *Standard Specifications* and is incidental to the cost of the guardrail end unit.

Measurement and Payment

Measurement and payment will be made in accordance with Article 862-6 of the *Standard Specifications*.

Payment will be made under:

Pay Item	Pay Unit
Guardrail End Units, Type TL-2	Each
Temporary Guardrail End Units, Type TL-2	Each

GUARDRAIL END UNITS & TEMPORARY GUARDRAIL END UNITS, TYPE - TL-3:

(4-20-04) (Rev. 5-16-23)

862

SP8 R65

Description

Furnish and install guardrail end units in accordance with the details in the plans, the applicable requirements of Section 862 of the *Standard Specifications*, and at locations shown in the plans.

Materials

Furnish guardrail end units listed on the NCDOT APL. Units shall not be modified by the manufacturer and installer once approved and on the NCDOT APL.

Prior to installation the Contractor shall submit to the Engineer certified working drawings and assembling instructions from the manufacturer for each guardrail end unit in accordance with Article 105-2 of the *Standard Specifications*.

Perform installation in accordance with the details in the plans, and details and assembling instructions furnished by the manufacturer.

Construction Methods

Guardrail end delineation is required on all approach and trailing end sections for both temporary and permanent installations. Guardrail end delineation consists of yellow reflective sheeting applied to the entire end section of the guardrail in accordance with Article 1088-3 of the *Standard Specifications* and is incidental to the cost of the guardrail end unit.

Measurement and Payment

Measurement and payment will be made in accordance with Article 862-6 of the *Standard Specifications*.

Payment will be made under:

Pay Item	Pay Unit
Guardrail End Units, Type TL-3	Each
Temporary Guardrail End Units, Type TL-3	Each

GUARDRAIL ANCHOR UNITS AND TEMPORARY GUARDRAIL ANCHOR UNITS:

(1-16-2018)

862

SP8 R70

Guardrail anchor units will be in accordance with the details in the plans and the applicable requirements of Section 862 of the *2018 Standard Specifications*.

Revise the *2018 Standard Specifications* as follows:

Page 8-42, Article 862-6 MEASUREMENT AND PAYMENT, add the following:

Guardrail Anchor Units, Type ___ and Temporary Guardrail Anchor Units Type ___ will be measured and paid as units of each completed and accepted. No separate measurement will be made of any rail, terminal sections, posts, offset blocks, concrete, hardware or any other components of the completed unit that are within the pay limits shown in the plans for the unit as all such components will be considered to be part of the unit.

Payment will be made under:

Pay Item	Pay Unit
Guardrail Anchor Units, Type _____	Each
Temporary Guardrail Anchor Units, Type _____	Each

ADJUSTMENT OF CATCH BASINS, MANHOLES, DROP INLETS, METER BOXES AND VALVE BOXES:

(11-15-22)

858

SP8 R98R

Revise the *2018 Standard Specifications* as follows:

Page 8-38, Article 858-4 MEASUREMENT AND PAYMENT, lines 10-11, delete and replace the fifth paragraph with the following:

Where any catch basin, drop inlet, manhole, meter box or valve box is adjusted more than once because of milling operations, each adjustment will be measured and paid.

FOUNDATIONS AND ANCHOR ROD ASSEMBLIES FOR METAL POLES:

(1-17-12) (Rev. 1-16-18)

9, 14, 17

SP9 R05

Description

Foundations for metal poles include foundations for signals, cameras, overhead and dynamic message signs (DMS) and high mount and light standards supported by metal poles or upright trusses. Foundations consist of footings with pedestals and drilled piers with or without grade beams or wings. Anchor rod assemblies consist of anchor rods (also called anchor bolts) with nuts and washers on the exposed ends of rods and nuts and a plate or washers on the other ends of rods embedded in the foundation.

Construct concrete foundations with the required resistances and dimensions and install anchor rod assemblies in accordance with the contract and accepted submittals. Construct drilled piers consisting of cast-in-place reinforced concrete cylindrical sections in excavated holes. Provide temporary casings or polymer slurry as needed to stabilize drilled pier excavations. Use a prequalified Drilled Pier Contractor to construct drilled piers for metal poles. Define “excavation” and “hole” as a drilled pier excavation and “pier” as a drilled pier.

This provision does not apply to foundations for signal pedestals; see Section 1743 of the *2018 Standard Specifications* and 2018 Roadway Standard Drawing No. 1743.01.

Materials

Refer to the *2018 Standard Specifications*.

Item	Section
Conduit	1091-3
Grout, Type 2	1003
Polymer Slurry	411-2(B)(2)
Portland Cement Concrete	1000
Reinforcing Steel	1070
Rollers and Chairs	411-2(C)
Temporary Casings	411-2(A)

Provide Type 3 material certifications in accordance with Article 106-3 of the *2018 Standard Specifications* for conduit, rollers, chairs and anchor rod assemblies. Store steel materials on blocking at least 12" above the ground and protect it at all times from damage; and when placing in the work make sure it is free from dirt, dust, loose mill scale, loose rust, paint, oil or other foreign materials. Load, transport, unload and store foundation and anchor rod assembly materials so materials are kept clean and free of damage. Bent, damaged or defective materials will be rejected.

Use conduit type in accordance with the contract. Use Class A concrete for footings and pedestals, Class Drilled Pier concrete for drilled piers and Class AA concrete for grade beams and wings including portions of drilled piers above bottom of wings elevations. Corrugated temporary

casings may be accepted at the discretion of the Engineer. A list of approved polymer slurry products is available from:

connect.ncdot.gov/resources/Geological/Pages/Products.aspx

Provide anchor rod assemblies in accordance with the contract consisting of the following:

- (A) Straight anchor rods,
- (B) Heavy hex top and leveling nuts and flat washers on exposed ends of rods, and
- (C) Nuts and either flat plates or washers on the other ends of anchor rods embedded in foundations.

Do not use lock washers. Use steel anchor rods, nuts and washers that meet ASTM F1554 for Grade 55 rods and Grade A nuts. Use steel plates and washers embedded in concrete with a thickness of at least 1/4". Galvanize anchor rods and exposed nuts and washers in accordance with Article 1076-4 of the *2018 Standard Specifications*. It is not necessary to galvanize nuts, plates and washers embedded in concrete.

Construction Methods

Install the required size and number of conduits in foundations in accordance with the plans and accepted submittals. Construct top of piers, footings, pedestals, grade beams and wings flat, level and within 1" of elevations shown in the plans or approved by the Engineer. Provide an Ordinary Surface finish in accordance with Subarticle 825-6(B) of the *2018 Standard Specifications* for portions of foundations exposed above finished grade. Do not remove anchor bolt templates or pedestal or grade beam forms or erect metal poles or upright trusses onto foundations until concrete attains a compressive strength of at least 3,000 psi.

(A) Drilled Piers

Before starting drilled pier construction, hold a predrill meeting to discuss the installation, monitoring and inspection of the drilled piers. Schedule this meeting after the Drilled Pier Contractor has mobilized to the site. The Resident or Division Traffic Engineer, Contractor and Drilled Pier Contractor Superintendent will attend this predrill meeting.

Do not excavate holes, install piles or allow equipment wheel loads or vibrations within 20 ft of completed piers until 16 hours after Drilled Pier concrete reaches initial set.

Check for correct drilled pier alignment and location before beginning drilling. Check plumbness of holes frequently during drilling.

Construct drilled piers with the minimum required diameters shown in the plans. Install piers with tip elevations no higher than shown in the plans or approved by the Engineer.

Excavate holes with equipment of the sizes required to construct drilled piers. Depending on the subsurface conditions encountered, drilling through rock and boulders may be required. Do not use blasting for drilled pier excavations.

Contain and dispose of drilling spoils and waste concrete as directed and in accordance with Section 802 of the *2018 Standard Specifications*. Drilling spoils consist of all materials and fluids removed from excavations.

If unstable, caving or sloughing materials are anticipated or encountered, stabilize holes with temporary casings and/or polymer slurry. Do not use telescoping temporary casings. If it becomes necessary to replace a temporary casing during drilling, backfill the excavation, insert a larger casing around the casing to be replaced or stabilize the excavation with polymer slurry before removing the temporary casing.

If temporary casings become stuck or the Contractor proposes leaving casings in place, temporary casings should be installed against undisturbed material. Unless otherwise approved, do not leave temporary casings in place for mast arm poles and cantilever signs. The Engineer will determine if casings may remain in place. If the Contractor proposes leaving temporary casings in place, do not begin drilling until a casing installation method is approved.

Use polymer slurry and additives to stabilize holes in accordance with the slurry manufacturer's recommendations. Provide mixing water and equipment suitable for polymer slurry. Maintain the required slurry properties at all times except for sand content.

Define a "sample set" as slurry samples collected from mid-height and within 2 ft of the bottom of holes. Take sample sets from excavations to test polymer slurry immediately after filling holes with slurry, at least every 4 hours thereafter and immediately before placing concrete. Do not place Drilled Pier concrete until both slurry samples from an excavation meet the required polymer slurry properties. If any slurry test results do not meet the requirements, the Engineer may suspend drilling until both samples from a sample set meet the required polymer slurry properties.

Remove soft and loose material from bottom of holes using augers to the satisfaction of the Engineer. Assemble rebar cages and place cages and Drilled Pier concrete in accordance with Subarticle 411-4(E) of the *2018 Standard Specifications* except for the following:

- (1) Inspections for tip resistance and bottom cleanliness are not required,
- (2) Temporary casings may remain in place if approved, and
- (3) Concrete placement may be paused near the top of pier elevations for anchor rod assembly installation and conduit placement or
- (4) If applicable, concrete placement may be stopped at bottom of grade beam or wings elevations for grade beam or wing construction.

If wet placement of concrete is anticipated or encountered, do not place Drilled Pier concrete until a concrete placement procedure is approved. If applicable, temporary casings and fluids may be removed when concrete placement is paused or stopped in accordance with the exceptions above provided holes are stable. Remove contaminated concrete from exposed Drilled Pier concrete after removing casings and fluids. If holes are

unstable, do not remove temporary casings until a procedure for placing anchor rod assemblies and conduit or constructing grade beams or wings is approved.

Use collars to extend drilled piers above finished grade. Remove collars after Drilled Pier concrete sets and round top edges of piers.

If drilled piers are questionable, pile integrity testing (PIT) and further investigation may be required in accordance with Article 411-5 of the *2018 Standard Specifications*. A drilled pier will be considered defective in accordance with Subarticle 411-5(D) of the *2018 Standard Specifications* and drilled pier acceptance is based in part on the criteria in Article 411-6 of the *2018 Standard Specifications* except for the top of pier tolerances in Subarticle 411-6(C) of the *2018 Standard Specifications*.

If a drilled pier is under further investigation, do not grout core holes, backfill around the pier or perform any work on the drilled pier until the Engineer accepts the pier. If the drilled pier is accepted, dewater and grout core holes and backfill around the pier with approved material to finished grade. If the Engineer determines a pier is unacceptable, remediation is required in accordance with Article 411-6 of the *2018 Standard Specifications*. No extension of completion date or time will be allowed for remediation of unacceptable drilled piers or post repair testing.

Permanently embed a plate in or mark top of piers with the pier diameter and depth, size and number of vertical reinforcing bars and the minimum compressive strength of the concrete mix at 28 days.

(B) Footings, Pedestals, Grade Beams and Wings

Excavate as necessary for footings, grade beams and wings in accordance with the plans, accepted submittals and Section 410 of the *2018 Standard Specifications*. If unstable, caving or sloughing materials are anticipated or encountered, shore foundation excavations as needed with an approved method. Notify the Engineer when foundation excavation is complete. Do not place concrete or reinforcing steel until excavation dimensions and foundation material are approved.

Construct cast-in-place reinforced concrete footings, pedestals, grade beams and wings with the dimensions shown in the plans and in accordance with Section 825 of the *2018 Standard Specifications*. Use forms to construct portions of pedestals and grade beams protruding above finished grade. Provide a chamfer with a 3/4" horizontal width for pedestal and grade beam edges exposed above finished grade. Place concrete against undisturbed soil or backfill and fill in accordance with Article 410-8 of the *2018 Standard Specifications*. Proper compaction around footings and wings is critical for foundations to resist uplift and torsion forces.

(C) Anchor Rod Assemblies

Size anchor rods for design and the required projection above top of foundations. Determine required anchor rod projections from nut, washer and base plate thicknesses,

the protrusion of 3 to 5 anchor rod threads above top nuts after tightening and the distance of one nut thickness between top of foundations and bottom of leveling nuts.

Protect anchor rod threads from damage during storage and installation of anchor rod assemblies. Before placing anchor rods in foundations, turn nuts onto and off rods past leveling nut locations. Turn nuts with the effort of one workman using an ordinary wrench without a cheater bar. Report any thread damage to the Engineer that requires extra effort to turn nuts.

Arrange anchor rods symmetrically about center of base plate locations as shown in the plans. Set anchor rod elevations based on required projections above top of foundations. Securely brace and hold rods in the correct position, orientation and alignment with a steel template. Do not weld to reinforcing steel, temporary casings or anchor rods.

Install top and leveling (bottom) nuts, washers and the base plate for each anchor rod assembly in accordance with the following procedure:

- (1) Turn leveling nuts onto anchor rods to a distance of one nut thickness between the top of foundation and bottom of leveling nuts. Place washers over anchor rods on top of leveling nuts.
- (2) Determine if nuts are level using a flat rigid template on top of washers. If necessary, lower leveling nuts to level the template in all directions or if applicable, lower nuts to tilt the template so the metal pole or upright truss will lean as shown in the plans. If leveling nuts and washers are not in full contact with the template, replace washers with galvanized beveled washers.
- (3) Verify the distance between the foundation and leveling nuts is no more than one nut thickness.
- (4) Place base plate with metal pole or upright truss over anchor rods on top of washers. High mount luminaires may be attached before erecting metal poles but do not attach cables, mast arms or trusses to metal poles or upright trusses at this time.
- (5) Place washers over anchor rods on top of base plate. Lubricate top nut bearing surfaces and exposed anchor rod threads above washers with beeswax, paraffin or other approved lubricant.
- (6) Turn top nuts onto anchor rods. If nuts are not in full contact with washers or washers are not in full contact with the base plate, replace washers with galvanized beveled washers.
- (7) Tighten top nuts to snug-tight with the full effort of one workman using a 12" wrench. Do not tighten any nut all at once. Turn top nuts in increments. Follow a star pattern cycling through each nut at least twice.
- (8) Repeat (7) for leveling nuts.
- (9) Replace washers above and below the base plate with galvanized beveled washers if the slope of any base plate face exceeds 1:20 (5%), any washer is not in firm contact with the base plate or any nut is not in firm contact with a washer. If any washers are replaced, repeat (7) and (8).

- (10) With top and leveling nuts snug-tight, mark each top nut on a corner at the intersection of 2 flats and a corresponding reference mark on the base plate. Mark top nuts and base plate with ink or paint that is not water-soluble. Use the turn-of-nut method for pretensioning. Do not pretension any nut all at once. Turn top nuts in increments for a total turn that meets the following nut rotation requirements:

NUT ROTATION REQUIREMENTS (Turn-of-Nut Pretensioning Method)	
Anchor Rod Diameter, inch	Requirement
$\leq 1 \frac{1}{2}$	1/3 turn (2 flats)
$> 1 \frac{1}{2}$	1/6 turn (1 flat)

Follow a star pattern cycling through each top nut at least twice.

- (11) Ensure nuts, washers and base plate are in firm contact with each other for each anchor rod. Cables, mast arms and trusses may now be attached to metal poles and upright trusses.
- (12) Between 4 and 14 days after pretensioning top nuts, use a torque wrench calibrated within the last 12 months to check nuts in the presence of the Engineer. Completely erect mast arm poles and cantilever signs and attach any hardware before checking top nuts for these structures. Check that top nuts meet the following torque requirements:

TORQUE REQUIREMENTS	
Anchor Rod Diameter, inch	Requirement, ft-lb
7/8	180
1	270
1 1/8	380
1 1/4	420
$\geq 1 \frac{1}{2}$	600

If necessary, retighten top nuts in the presence of the Engineer with a calibrated torque wrench to within ± 10 ft-lb of the required torque. Do not overtighten top nuts.

- (13) Do not grout under base plate.

Measurement and Payment

Foundations and anchor rod assemblies for metal poles and upright trusses will be measured and paid for elsewhere in the contract.

No payment will be made for temporary casings that remain in drilled pier excavations. No payment will be made for PIT. No payment will be made for further investigation of defective piers. Further investigation of piers that are not defective will be paid as extra work in accordance with Article 104-7 of the *2018 Standard Specifications*. No payment will be made for remediation of unacceptable drilled piers or post repair testing.

PORTLAND CEMENT CONCRETE PRODUCTION AND DELIVERY:

(9-15-20)

1000, 1014, 1024

SP10 R01

Revise the *2018 Standard Specifications* as follows:

Page 10-6, Table 1000-1, REQUIREMENTS FOR CONCRETE, replace with the following:

TABLE 1000-1 REQUIREMENTS FOR CONCRETE											
Class of Concrete	Min. Compressive Strength at 28 days	Maximum Water-Cement Ratio				Consistency Maximum Slump		Cement Content			
		Air-Entrained Concrete		Non-Air- Entrained Concrete		Vibrated	Non- Vibrated	Vibrated		Non-Vibrated	
		Rounded Aggregate	Angular Aggregate	Rounded Aggregate	Angular Aggregate			Min.	Max.	Min.	Max.
		Units	psi					inch	inch	lb/cy	lb/cy
AA	4500	0.381	0.426	---	---	3.5 ^A	---	639	715	---	---
AA Slip Form	4500	0.381	0.426	---	---	1.5	---	639	715	---	---
Drilled Pier	4500	---	---	0.450	0.450	---	5 - 7 dry 7 - 9 wet	---	---	640	800
A	3000	0.488	0.532	0.550	0.594	3.5 ^A	4.0	564	---	602	---
B	2500	0.488	0.567	0.559	0.630	1.5 machine placed 2.5 ^A hand placed	4.0	508	---	545	---
Sand Light- weight	4500	---	0.420	---	---	4.0 ^A	---	715	---	---	---
Latex Modified	3000 (at 7 days)	0.400	0.400	---	---	6.0	---	658	---	---	---
Flowable Fill excavatable	150 max. (at 56 days)	as needed	as needed	as needed	as needed	---	Flowable	---	---	40	100
Flowable Fill non- excavatable	125	as needed	as needed	as needed	as needed	---	Flowable	---	---	100	as needed
Pavement	4500 Design, field 650 flexural, design only	0.559	0.559	---	---	1.5 slip form 3.0 hand placed	---	526	---	---	---
Precast	See Table 1077-1	as needed	as needed	---	---	6.0	as needed	as needed	as needed	as needed	as needed
Prestressed	per contract	See Table 1078-1	See Table 1078-1	---	---	8.0	---	564	as needed	---	---

- A. The slump may be increased to 6 inches, provided the increase in slump is achieved by adding a chemical admixture conforming to Section 1024-3. In no case shall the water-cement ratio on the approved design be exceeded. Concrete exhibiting segregation and/or excessive bleeding will be rejected. Utilizing an Admixture to modify slump does not relinquish the contractor's responsibility to ensure the final product quality and overall configuration meets design specifications. Caution should be taken when placing these modified mixes on steep grades to prevent unintended changes to the set slope.

THERMOPLASTIC INTERMIXED BEAD TESTING:

7-19-22

1087

SP10 R04

Revise the *2018 Standard Specifications* as follows:

Page 10-183, Subarticle 1087-7(B) Thermoplastic Pavement Marking Material Composition, delete line 34 and 35.

Page 10-184, Article 1087-8 MATERIAL CERTIFICATION, delete and replace with the following after line 34:

Drop-on Glass Beads	Type 3 Material Certification and Type 4 Material Certification
Intermix Glass Beads	Type 2 Material Certification and Type 3 Material Certification
Paint	Type 3 Material Certification
Removable Tape	Type 3 Material Certification
Thermoplastic	Type 3 Material Certification and Type 4 Material Certification
Cold Applied Plastic	Type 2 Material Certification and Type 3 Material Certification
Polyurea	Type 2 Material Certification and Type 3 Material Certification

THERMOPLASTIC PAVEMENT MARKING MATERIAL – COLOR TESTING:

3-19-19

1087

SP10 R05

Revise the *2018 Standard Specifications* as follows:

Pages 10-183 and 10-184, Subarticle 1087-7(D)(1)(b) Yellow, lines 9-11, delete and replace with the following:

Obtain Color Values Y,x,y per ASTM E1349 using C/2° illuminant/observer. Results shall be $Y \geq 45\%$, and x,y shall fall within PR#1 chart chromaticity limits.

NON-CAST IRON SNOWPLOWABLE PAVEMENT MARKERS:

10-19-21 (Rev. 11-16-21)

1086, 1250, 1253

SP10 R08

Revise the *2018 Standard Specifications* as follows:

Pages 10-177 and 10-178, Subarticle 1086-3 SNOWPLOWABLE PAVEMENT MARKERS, delete items (A), (B) and (C)(1) and replace with the following:

(A) General

Use non-cast iron snowplowable pavement markers evaluated by NTPEP. The non-cast iron snowplowable pavement marker shall consist of a housing with one or more glass or plastic face lens type reflective lenses to provide the required color designation. The marker shall be designed or installed in a manner that minimizes damage from snowplow blades. Plastic lens faces shall use an abrasion resistant coating.

(B) Housings**(1) Dimensions**

The dimension, slope and minimum area of reflecting surface shall conform to dimensions as shown in the plans. The minimum area of each reflecting surface shall be 1.44 sq.in.

(2) Materials

Use non-cast iron snowplowable pavement markers that are on the NCDOT Approved Products List.

(3) Surface

The surface of the housing shall be free of scale, dirt, rust, oil, grease or any other contaminant which might reduce its bond to the epoxy adhesive.

(4) Identification

Mark the housing with the manufacturer's name and model number of marker.

(C) Reflectors**(1) General**

Laminate the reflector to an elastomeric pad and attach with adhesive to the housing. The thickness of the elastomeric pad shall be 0.04".

Pages 12-14, Subarticle 1250-3(C) Removal of Existing Pavement Markers, lines 19-29, delete and replace with the following:

Remove the existing raised pavement markers or the snowplowable pavement markers including the housings, before overlaying an existing roadway with pavement. Repair the pavement by filling holes as directed by the Engineer.

When traffic patterns are changed in work zones due to construction or reconstruction, remove all raised pavement markers or snowplowable markers including housings that conflict with the new traffic pattern before switching traffic to the new traffic pattern. Lens removal in lieu of total housing removal is not an acceptable practice for snowplowable markers.

Properly dispose of the removed pavement markers. No direct payment will be made for removal or disposal of existing pavement markers or repair of pavement, as such work will be incidental to other items in the contract.

Pages 12-16, Subarticle 1253-1 DESCRIPTION, lines 4-5, delete and replace with the following:

Furnish, install and maintain non-cast iron snowplowable pavement markers in accordance with the contract.

Pages 12-16 and 12-17, Subarticle 1253-3 CONSTRUCTION METHODS, delete items (A), (B) and (C) and replace with the following:

(A) General

Bond marker housings to the pavement with epoxy adhesive. Mechanically mix and dispense epoxy adhesives as required by the manufacturer's specifications. Place the markers immediately after the adhesive has been mixed and dispensed.

If saw cutting, milling, or grooving operations are used, promptly remove all resulting debris from the pavement surface. Install the marker housings within 7 calendar days after saw cutting, milling, or grooving the pavement. Remove and dispose of loose material from the slots by brushing, blow cleaning, or vacuuming. Dry the slots before applying the epoxy adhesive. Install non-cast iron snowplowable pavement markers according to the manufacturer's recommendations.

Protect the non-cast iron snowplowable pavement markers until the epoxy has initially cured and is track free.

(B) Reflector Replacement

In the event that a reflector is damaged, replace the damaged reflector by using adhesives and methods recommended by the manufacturer of the markers and approved by the Engineer. This work is considered incidental if damage occurs during the initial installation of the marker housings and maintenance of initial non-cast iron snowplowable markers specified in this section. This work will be paid for under the pay item for the type of reflector replacement if the damage occurred after the initial installation of the non-cast iron snowplowable pavement marker.

Missing housings shall be replaced. Broken housings shall be removed and replaced. In both cases the slot for the housings shall be properly prepared prior to installing the new housing; patch the existing marker slots as directed by the Engineer and install the new marker approximately one foot before or after the patch. Removal of broken housings and preparation of slots will be considered incidental to the work of replacing housings.

Pages 12-17, Subarticle 1253-4 MAINTENANCE, lines 5, delete and replace with the following:

Maintain all installed non-cast iron snowplowable pavement markers until acceptance.

Pages 12-17, Subarticle 1253-5 MEASUREMENT AND PAYMENT, lines 7-8, delete and replace with the following:

Non-Cast Iron Snowplowable Pavement Markers will be measured and paid as the actual number of non-cast iron snowplowable pavement markers satisfactorily placed and accepted by the Engineer.

Pages 12-17, Subarticle 1253-5 MEASUREMENT AND PAYMENT, lines 11, delete and replace with the following:

Payment will be made under:

Pay Item	Pay Unit
Non-Cast Iron Snowplowable Pavement Marker	Each
Replace Snowplowable Pavement Marker Reflector	Each

MATERIALS FOR PORTLAND CEMENT CONCRETE:

(9-15-20)

1000, 1024

SP10 R24

Revise the *2018 Standard Specifications* as follows:

Page 10-52, Article 1024-4, WATER, lines 3-6, delete and replace with the following:

Test water from wells at all locations. Test public water supplies from all out of state locations and in the following counties: Beaufort, Bertie, Brunswick, Camden, Carteret, Chowan, Craven, Currituck, Dare, Gates, Hyde, New Hanover, Onslow, Pamlico, Pasquotank, Pender, Perquimans, Tyrell and Washington unless the Engineer waives the testing requirements.

Page 10-52, Table 1024-2, PHYSICAL PROPERTIES OF WATER, replace with the following:

Property	Requirement	Test Method
Compression Strength, minimum percent of control at 3 and 7 days	90%	ASTM C1602
Time of set, deviation from control	From 1:00 hr. earlier to 1:30 hr. later	ASTM C1602
pH	4.5 to 8.5	ASTM D1293 *
Chloride Ion Content, Max.	250 ppm	ASTM D512 *
Total Solids Content (Residue), Max.	1,000 ppm	SM 2540B *
Resistivity, Min.	0.500 kohm-cm	ASTM D1125 *

*Denotes an alternate method is acceptable. Test method used shall be referenced in the test report.

GEOSYNTHETICS:

(03-21-23)(Rev. 4-18-23)

1056

SP10 R56

Revise the *Standard Specifications* as follows:

Page 10-77, Article 1056-1 DESCRIPTION, lines 13-16, delete and replace the second sentence in the second paragraph with the following:

Steel anchor pins shall have a diameter of at least 3/16 inch, a length of at least 18 inches, a point at one end and a head at the other end that will retain a steel washer with an outside diameter of at least 1.5 inches.

Page 10-77, Article 1056-2 HANDLING AND STORING, lines 20-21, delete and replace the third sentence in the first paragraph with the following:

Geosynthetics with defects, flaws, deterioration or damage will be rejected by the Engineer.

Page 10-77, Article 1056-3 CERTIFICATIONS AND IDENTIFICATION, lines 25-27, delete and replace the first sentence in the first paragraph with the following:

Provide Type 1, Type 2 or Type 4 material certifications in accordance with Article 106-3 for geosynthetics except certifications are not required for Type 1 through Type 5 geotextiles.

Page 10-77, Article 1056-3 CERTIFICATIONS AND IDENTIFICATION, lines 32-35, delete the second paragraph.

Page 10-77, Article 1056-3 CERTIFICATIONS AND IDENTIFICATION, lines 36-41, delete and replace the third paragraph with the following:

Allow the Engineer to visually identify geosynthetic products before installation. Open packaged geosynthetics just before use in the presence of the Engineer to verify the correct product. Geosynthetics that are missing original packaging or product labels or that have been unwrapped or previously opened will be rejected unless otherwise approved by the Engineer.

Page 10-77, Article 1056-4 GEOTEXTILES, lines 43-45, delete the first paragraph.

Page 10-78, Article 1056-4 GEOTEXTILES, before line 1 and lines 1-5, delete Table 1056-1 and lines 1-5 and replace with the following:

TABLE 1056-1 GEOTEXTILE REQUIREMENTS						
Property ^A	Requirement (MARV ^A)					Test Method
	Type 1	Type 2	Type 3 ^B	Type 4	Type 5 ^C	
<i>Typical Application</i>	<i>Shoulder Drains</i>	<i>Under Rip Rap</i>	<i>Silt Fence Fabric</i>	<i>Soil Stabilization</i>	<i>Subgrade Stabilization</i>	
Elongation (MD & CD)	≥ 50%	≥ 50%	≤ 25%	< 50%	< 50%	ASTM D4632
Grab Strength (MD & CD) ^A	Table 1 ^D , Class 3	Table 1 ^D , Class 1	100 lb	Table 1 ^D , Class 3	-	ASTM D4632
Tear Strength (MD & CD) ^A			-			ASTM D4533
Puncture Strength			-			ASTM D6241
Ultimate Tensile Strength (MD & CD) ^A	-	-	-	-	Table 12 ^D , Class 4A	ASTM D4595
Permittivity	Table 2 ^D , 15% to 50% <i>in Situ</i> Soil Passing 0.075 mm	Table 6 ^D , 15% to 50% <i>in Situ</i> Soil Passing 0.075 mm	Table 7 ^D	Table 5 ^D	Table 12 ^D , Class 4A	ASTM D4491
Apparent Opening Size						ASTM D4751
UV Stability (Retained Strength)						ASTM D4355

A. MD, CD and MARV per Article 1056-3.

B. Minimum roll width of 36 inches required.

C. Minimum roll width of 13 feet required unless otherwise approved by the Engineer for the application.

D. Per AASHTO M 288.

Page 10-78, Article 1056-5 GEOCOMPOSITE DRAINS, before line 9 and lines 9-10, delete Table 1056-2 and lines 9-10 and replace with the following:

TABLE 1056-2 GEOCOMPOSITE DRAIN REQUIREMENTS				
Property	Requirement			Test Method
	Sheet Drain	Strip Drain	Wick Drain	
Width	≥ 12"	12" ±1/4"	4" ±1/4"	N/A
In-Plane Flow Rate ^A (with gradient of 1.0 and 24-hour seating period)	6 gpm/ft @ applied normal compressive stress of 10 psi	15 gpm/ft @ applied normal compressive stress of 7.26 psi	1.5 gpm ^B @ applied normal compressive stress of 1.45 psi	ASTM D4716

A. MARV per Article 1056-3.

B. Per foot of width tested.

Page 10-79, Article 1056-5 GEOCOMPOSITE DRAINS, before line 3, delete Table 1056-3 and replace with the following:

TABLE 1056-3 DRAINAGE CORE REQUIREMENTS			
Property	Requirement		Test Method
	Sheet Drain	Strip Drain	
Thickness	1/4"	1"	ASTM D1777 or D5199
Compressive Strength ^A	40 psi	30 psi	ASTM D6364

A. MARV per Article 1056-3.

Page 10-79, Article 1056-5 GEOCOMPOSITE DRAINS, before line 6 and lines 6-11, delete Table 1056-4, lines 6-7 and the last paragraph and replace with the following:

TABLE 1056-4 WICK DRAIN GEOTEXTILE REQUIREMENTS		
Property	Requirement	Test Method
Elongation	≥ 50%	ASTM D4632
Grab Strength	Table 1 ^A , Class 3	ASTM D4632
Tear Strength		ASTM D4533
Puncture Strength		ASTM D6241
Permittivity ^B	0.7 sec ⁻¹	ASTM D4491
Apparent Opening Size (AOS)	Table 2 ^A , > 50% <i>in Situ</i> Soil Passing 0.075 mm	ASTM D4751
UV Stability (Retained Strength)		ASTM D4355

A. Per AASHTO M 288.

B. MARV per Article 1056-3.

For wick drains with a geotextile fused to both faces of a corrugated drainage core along the peaks of the corrugations, use wick drains with an ultimate tensile strength of at least 1,650 lbs. per 4 inch width in accordance with ASTM D4595 and geotextiles with a permittivity, AOS and UV stability that meet Table 1056-4.

Page 10-80, Article 1056-6 GEOCELLS, before line 1 and lines 1-4, delete Table 1056-5 and lines 1-4 and replace with the following:

TABLE 1056-5 GEOCELL REQUIREMENTS		
Property	Requirement	Test Method
Cell Depth	4"	N/A
Fully Expanded Cell Area	100 sq.in. max	N/A
Sheet Thickness	50 mil -5%, +10%	ASTM D5199
Density	58.4 pcf min	ASTM D1505
Carbon Black Content	1.5% min	ASTM D1603 or D4218
ESCR ^A	5000 hr min	ASTM D1693
Coefficient of Direct Sliding (with material that meets AASHTO M 145 for soil classification A-2)	0.85 min	ASTM D5321
Short-Term Seam (Peel) Strength (for 4" seam)	320 lb min	USACE ^C Technical Report GL-86-19, Appendix A
Long-Term Seam (Hang) Strength ^B (for 4" seam)	160 lb min	

A. Environmental Stress Crack Resistance.

B. Minimum test period of 168 hours with a temperature change from 74°F to 130°F in 1-hour cycles.

C. US Army Corps of Engineers (USACE).

TEMPORARY SHORING:

(2-20-07) (Rev. 10-19-21)

SP11 R02

Description

Temporary shoring includes cantilever, braced and anchored shoring and temporary mechanically stabilized earth (MSE) walls. Temporary shoring does not include trench boxes. At the Contractor's option, use any type of temporary shoring unless noted otherwise in the plans or as directed. Design and construct temporary shoring based on actual elevations and shoring dimensions in accordance with the contract and accepted submittals. Construct temporary shoring at locations shown in the plans and as directed. Temporary shoring is required to maintain traffic when a 2:1 (H:V) slope from the top of an embankment or bottom of an excavation will intersect the existing ground line less than 5 feet from the edge of pavement of an open travelway. This provision does not apply to pipe, inlet or utility installation unless noted otherwise in the plans.

Positive protection includes concrete barrier and temporary guardrail. Provide positive protection for temporary shoring at locations shown in the plans and as directed. Positive protection is required if temporary shoring is located in the clear zone in accordance with the *AASHTO Roadside Design Guide*.

(A) Cantilever and Braced Shoring

Cantilever shoring consists of steel sheet piles or H-piles with timber lagging. Braced shoring consists of sheet piles or H-piles with timber lagging and bracing such as beams, plates, walers, struts, rakers, etc. Define "piles" as sheet piles or H-piles.

(B) Anchored Shoring

Anchored shoring consists of sheet piles with walers or H-piles with timber lagging anchored with ground or helical anchors. Driven anchors may be accepted at the discretion of the Engineer. A ground anchor consists of a grouted steel bar or multi-strand tendon with an anchorage. A helical anchor consists of a lead section with a central steel shaft and at least one helix steel plate followed by extensions with only central shafts (no helixes) and an anchorage. Anchorages consist of steel bearing plates with washers and hex nuts for bars or steel wedge plates and wedges for strands. Use a prequalified Anchored Wall Contractor to install ground anchors. Define “anchors” as ground, helical or driven anchors.

(C) Temporary MSE Walls

Temporary MSE walls include temporary geosynthetic and wire walls. Define “temporary wall” as a temporary MSE wall and “Temporary Wall Vendor” as the vendor supplying the temporary MSE wall. Define “reinforcement” as geotextile, geogrid, geostrip, welded wire grid or metallic strip reinforcement.

Temporary geosynthetic walls consist of geotextiles or geogrids wrapped behind welded wire facing or geostrips connected to welded wire facing. Define “temporary geotextile wall” as a temporary geosynthetic wall with geotextile reinforcement, “temporary geogrid wall” as a temporary geosynthetic wall with geogrid reinforcement and “temporary geostrip wall” as a temporary geosynthetic wall with geostrip reinforcement.

Temporary wire walls consist of welded wire grid or metallic strip reinforcement connected to welded wire facing. Define “Wire Wall Vendor” as the vendor supplying the temporary wire wall.

(D) Embedment

Define “embedment” for cantilever, braced and anchored shoring as the pile depth below the grade in front of shoring. Define “embedment” for temporary walls as the wall embedment below the grade at the wall face.

(E) Positive Protection

Define “unanchored or anchored portable concrete barrier” as portable concrete barrier (PCB) that meets 2018 Roadway Standard Drawing No. 1170.01. Define “concrete barrier” as unanchored or anchored PCB or an approved equal. Define “temporary guardrail” as temporary steel beam guardrail that meets 2018 Roadway Standard Drawing No. 862.02.

Materials

Refer to the *2018 Standard Specifications*.

Item

Concrete Barrier Materials

Section

1170-2

Item	Section
Flowable Fill, Excavatable	1000-6
Geosynthetics	1056
Grout, Type 1	1003
Portland Cement	1024-1
Portland Cement Concrete	1000
Select Materials	1016
Steel Beam Guardrail Materials	862-2
Steel Plates	1072-2
Steel Sheet Piles and H-Piles	1084
Untreated Timber	1082-2
Water	1024-4
Welded Wire Reinforcement	1070-3

Provide Type 6 material certifications for shoring materials in accordance with Article 106-3 of the *2018 Standard Specifications*. Use Class IV select material for temporary guardrail and Class A concrete that meets Article 450-2 of the *2018 Standard Specifications* or Type 1 grout for drilled-in piles. Provide untreated timber with a thickness of at least 3 inches and a bending stress of at least 1,000 pounds per square inch for timber lagging. Provide steel bracing that meets ASTM A36.

(A) Shoring Backfill

Use Class II, Type 1, Class III, Class V or Class VI select material or material that meets AASHTO M 145 for soil classification A-2-4 with a maximum PI of 6 for shoring backfill except do not use A-2-4 soil for backfill around culverts.

(B) Anchors

Store anchor materials on blocking a minimum of 12 inches above the ground and protect it at all times from damage; and when placing in the work make sure it is free from dirt, dust, loose mill scale, loose rust, paint, oil or other foreign materials. Load, transport, unload and store anchor materials so materials are kept clean and free of damage. Bent, damaged or defective materials will be rejected.

(1) Ground Anchors

Use high-strength deformed steel bars that meet AASHTO M 275 or seven-wire strands that meet ASTM A886 or Article 1070-5 of the *2018 Standard Specifications*. Splice bars in accordance with Article 1070-9 of the *2018 Standard Specifications*. Do not splice strands. Use bondbreakers, spacers and centralizers that meet Article 6.3.5 of the *AASHTO LRFD Bridge Construction Specifications*.

Use neat cement grout that only contains cement and water with a water cement ratio of 0.4 to 0.5 which is approximately 5.5 gallons of water per 94 pounds of Portland cement. Provide grout with a compressive strength at 3 and 28 days of at least 1,500 and 4,000 psi, respectively.

(2) Helical Anchors

Use helical anchors with an ICC Evaluation Service, Inc. (ICC-ES) report. Provide couplers, thread bar adapters and bolts recommended by the Anchor Manufacturer to connect helical anchors together and to piles.

(3) Anchorages

Provide steel plates for bearing plates and steel washers, hex nuts, wedge plates and wedges recommended by the Anchor Manufacturer.

(C) Temporary Walls

(1) Welded Wire Facing

Use welded wire reinforcement for welded wire facing, struts and wires. For temporary wire walls, provide welded wire facing supplied by the Wire Wall Vendor or a manufacturer approved or licensed by the vendor. For temporary wire walls with separate reinforcement and facing components, provide connectors (e.g., bars, clamps, plates, etc.) and fasteners (e.g., bolts, nuts, washers, etc.) required by the Wire Wall Vendor.

(2) Geotextiles

Provide Type 2 geotextile for separation and retention geotextiles. Provide Type 5 geotextile for geotextile reinforcement with ultimate tensile strengths in accordance with the accepted submittals.

(3) Geogrid and Geostrip Reinforcement

Use geogrids with a roll width of at least 4 feet. Use geogrids for geogrid reinforcement and geostrips for geostrip reinforcement with an “approved” status code in accordance with the NCDOT Geosynthetic Reinforcement Evaluation Program. The list of approved geogrids and geostrips is available from: connect.ncdot.gov/resources/Geological/Pages/Products.aspx

Provide geogrids and geostrips with design strengths in accordance with the accepted submittals. Geogrids and geostrips are approved for short-term design strengths (3-year design life) in the machine direction (MD) and cross-machine direction (CD) based on material type. Define material type from the website above for shoring backfill as follows:

Material Type	Shoring Backfill
Borrow	A-2-4 Soil
Fine Aggregate	Class II, Type 1 or Class III Select Material
Coarse Aggregate	Class V or VI Select Material

(4) Welded Wire Grid and Metallic Strip Reinforcement

Provide welded wire grid and metallic strip reinforcement supplied by the Wire Wall Vendor or a manufacturer approved or licensed by the vendor. Use welded wire grid reinforcement (“mesh”, “mats” and “ladders”) that meet Article 1070-3 of the *2018 Standard Specifications* and metallic strip reinforcement (“straps”) that meet ASTM A572 or A1011.

Preconstruction Requirements

(A) Concrete Barrier

Define “clear distance” behind concrete barrier as the horizontal distance between the barrier and edge of pavement. The minimum required clear distance for concrete barrier is shown in the plans. At the Contractor’s option or if the minimum required clear distance is not available, set concrete barrier next to and up against traffic side of temporary shoring except for barrier above temporary walls. Concrete barrier with the minimum required clear distance is required above temporary walls.

(B) Temporary Guardrail

Define “clear distance” behind temporary guardrail as the horizontal distance between guardrail posts and temporary shoring. At the Contractor’s option or if clear distance for cantilever, braced and anchored shoring is less than 4 feet, attach guardrail to traffic side of shoring as shown in the plans. Place ABC in clear distance and around guardrail posts instead of pavement. Do not use temporary guardrail above temporary walls.

(C) Temporary Shoring Designs

Before beginning temporary shoring design, survey existing ground elevations in the vicinity of shoring locations to determine actual design heights (H). Submit PDF files of working drawings and design calculations for temporary shoring designs in accordance with Article 105-2 of the *2018 Standard Specifications*. Submit working drawings showing plan views, shoring profiles, typical sections and details of temporary shoring design and construction sequence. Do not begin shoring construction until a design submittal is accepted.

Have cantilever and braced shoring designed, detailed and sealed by an engineer licensed in the state of North Carolina. Use a prequalified Anchored Wall Design Consultant to design anchored shoring. Provide anchored shoring designs sealed by a Design Engineer approved as a Geotechnical Engineer (key person) for an Anchored Wall Design Consultant. Include details in anchored shoring working drawings of anchor locations and lock-off loads, unit grout/ground bond strengths for ground anchors or minimum installation torque and torsional strength rating for helical anchors and if necessary, obstructions extending through shoring or interfering with anchors. Include details in the anchored shoring construction sequence of pile and anchor installation, excavation and anchor testing.

Provide temporary wall designs sealed by a Design Engineer licensed in the state of North

Carolina and employed or contracted by the Temporary Wall Vendor. Include details in temporary wall working drawings of geotextile and reinforcement types, locations and directions and obstructions extending through walls or interfering with reinforcement.

(1) Soil Parameters

Design temporary shoring for the assumed soil parameters and groundwater or flood elevations shown in the plans. Assume the following soil parameters for shoring backfill:

(a) Unit weight (γ) = 120 pcf,

(b)

Friction Angle (ϕ)	Shoring Backfill
30°	A-2-4 Soil
34°	Class II, Type 1 or Class III Select Material
38°	Class V or VI Select Material

(c) Cohesion (c) = 0 psf.

(2) Traffic Surcharge

Design temporary shoring for a traffic surcharge of 250 pounds per square foot if traffic will be above and within H of shoring. This traffic surcharge does not apply to construction traffic. Design temporary shoring for any construction surcharge if construction traffic will be above and within H of shoring. Design temporary shoring for a traffic (live load) surcharge in accordance with Article 11.5.6 of the *AASHTO LRFD Bridge Design Specifications*.

(3) Cantilever, Braced and Anchored Shoring Designs

Use shoring backfill for fill sections and voids between cantilever, braced and anchored shoring and the critical failure surface. Use concrete or Type 1 grout for embedded portions of drilled-in H-piles. Do not use drilled-in sheet piles.

Define “top of shoring” for cantilever, braced and anchored shoring as where the grade intersects the back of sheet piles or H-piles and timber lagging. Design cantilever, braced and anchored shoring for a traffic impact load of 2,000 pounds per foot applied 18 inches above top of shoring if concrete barrier is above and next to shoring or temporary guardrail is above and attached to shoring. Extend cantilever, braced and anchored shoring at least 32 inches above top of shoring if shoring is designed for traffic impact. Otherwise, extend shoring at least 6 inches above top of shoring.

Design cantilever, braced and anchored shoring for a maximum deflection of 3 inches if the horizontal distance to the closest edge of pavement or structure is less than H. Otherwise, design shoring for a maximum deflection of 6 inches. Design cantilever and braced shoring in accordance with the plans and *AASHTO Guide Design Specifications for Bridge Temporary Works*.

Design anchored shoring in accordance with the plans and Article 11.9 of the *AASHTO LRFD Bridge Design Specifications*. Use a resistance factor of 0.80 for tensile resistance of anchors with bars, strands or shafts. Extend the unbonded length for ground anchors and the shallowest helix for helical anchors at least 5 feet behind the critical failure surface. Do not extend anchors beyond right-of-way or easement limits. If existing or future obstructions such as foundations, guardrail posts, pavements, pipes, inlets or utilities will interfere with anchors, maintain a clearance of at least 6 inches between obstructions and anchors.

(4) Temporary Wall Designs

Use shoring backfill in the reinforced zone of temporary walls. Separation geotextiles are required between shoring backfill and backfill, natural ground or culverts along the sides of the reinforced zone perpendicular to the wall face. For Class V or VI select material in the reinforced zone, separation geotextiles are also required between shoring backfill and backfill or natural ground on top of and at the back of the reinforced zone.

Design temporary walls in accordance with the plans and Article 11.10 of the *AASHTO LRFD Bridge Design Specifications*. Embed temporary walls at least 18 inches except for walls on structures or rock as determined by the Engineer. Use a uniform reinforcement length throughout the wall height of at least $0.7H$ or 6 feet, whichever is longer. Extend the reinforced zone at least 6 inches beyond end of reinforcement. Do not locate the reinforced zone outside right-of-way or easement limits.

Use the simplified method for determining maximum reinforcement loads in accordance with the AASHTO LRFD specifications. For geotextile reinforcement, use geotextile properties approved by the Department or default values in accordance with the AASHTO LRFD specifications. For geogrid and geostrip reinforcement, use approved geosynthetic reinforcement properties available from the website shown elsewhere in this provision. Use geosynthetic properties for the direction reinforcement will be installed, a 3-year design life and shoring backfill to be used in the reinforced zone.

Do not use more than 4 different reinforcement strengths for each temporary geosynthetic wall. Design temporary geotextile walls for a reinforcement coverage ratio (R_c) of 1.0. For temporary geogrid walls with an R_c of less than 1.0, use a maximum horizontal clearance between geogrids of 3 feet and stagger reinforcement so geogrids are centered over gaps in the reinforcement layer below.

For temporary geosynthetic walls, use “L” shaped welded wire facing with 18 to 24 inch long legs. Locate geosynthetic reinforcement so reinforcement layers are at the same level as the horizontal legs of welded wire facing. Use vertical reinforcement spacing equal to facing height. Wrap geotextile or geogrid reinforcement behind welded wire facing and extend reinforcement at least 3 feet back behind facing into shoring backfill. Attach geostrip reinforcement to welded

wire facing with a connection approved by the Department.

For temporary wire walls with separate reinforcement and facing components, attach welded wire grid or metallic strip reinforcement to welded wire facing with a connection approved by the Department. For temporary geogrid, geostrip and wire walls, retain shoring backfill at welded wire facing with retention geotextiles and extend geotextiles at least 3 feet back behind facing into backfill.

(D) Preconstruction Meeting

The Engineer may require a shoring preconstruction meeting to discuss the construction, inspection and testing of the temporary shoring. If required and if this meeting occurs before all shoring submittals have been accepted, additional preconstruction meetings may be required before beginning construction of temporary shoring without accepted submittals. The Resident, District or Bridge Maintenance Engineer, Area Construction Engineer, Geotechnical Operations Engineer, Contractor and Shoring Contractor Superintendent will attend preconstruction meetings.

Construction Methods

Control drainage during construction in the vicinity of shoring. Direct run off away from shoring and shoring backfill. Contain and maintain backfill and protect material from erosion.

Install positive protection in accordance with the contract and accepted submittals. Use PCB in accordance with Section 1170 of the *2018 Standard Specifications* and 2018 Roadway Standard Drawing No. 1170.01. Use temporary guardrail in accordance with Section 862 of the *2018 Standard Specifications* and 2018 Roadway Standard Drawing Nos. 862.01, 862.02 and 862.03.

(A) Tolerances

Construct shoring with the following tolerances:

- (1) Horizontal wires of welded wire facing are level in all directions,
- (2) Shoring location is within 6 inches of horizontal and vertical alignment shown in the accepted submittals, and
- (3) Shoring plumbness (batter) is not negative and within 2 degrees of vertical.

(B) Cantilever, Braced and Anchored Shoring Installation

If overexcavation behind cantilever, braced or anchored shoring is shown in the accepted submittals, excavate before installing piles. Otherwise, install piles before excavating for shoring. Install cantilever, braced or anchored shoring in accordance with the construction sequence shown in the accepted submittals. Remove piles and if applicable, timber lagging when shoring is no longer needed.

(1) Pile Installation

Install piles with the minimum required embedment and extension in accordance with Subarticles 450-3(D) and 450-3(E) of the *2018 Standard Specifications* except that a pile driving equipment data form is not required. Piles may be installed with a vibratory hammer as approved by the Engineer.

Do not splice sheet piles. Use pile excavation to install drilled-in H-piles. After filling holes with concrete or Type 1 grout to the elevations shown in the accepted submittals, remove any fluids and fill remaining portions of holes with flowable fill. Cure concrete or grout at least 7 days before excavating.

Notify the Engineer if refusal is reached before pile excavation or driven piles attain the minimum required embedment. When this occurs, a revised design submittal may be required.

(2) Excavation

Excavate in front of piles from the top down in accordance with the accepted submittals. For H-piles with timber lagging and braced and anchored shoring, excavate in staged horizontal lifts with a maximum height of 5 feet. Remove flowable fill and material in between H-piles as needed to install timber lagging. Position lagging with at least 3 inches of contact in the horizontal direction between the lagging and pile flanges. Do not excavate the next lift until timber lagging for the current lift is installed and if applicable, bracing and anchors for the current lift are accepted. Backfill behind cantilever, braced or anchored shoring with shoring backfill.

(3) Anchor Installation

If applicable, install foundations located behind anchored shoring before installing anchors. Fabricate and install ground anchors in accordance with the accepted submittals, Articles 6.4 and 6.5 of the *AASHTO LRFD Bridge Construction Specifications* and the following unless otherwise approved:

- (a) Materials in accordance with this provision are required instead of materials conforming to Articles 6.4 and 6.5.3 of the AASHTO LRFD Specifications,
- (b) Encapsulation-protected ground anchors in accordance with Article 6.4.1.2 of the AASHTO LRFD specifications are not required, and
- (c) Corrosion protection for unbonded lengths of ground anchors and anchorage covers are not required.
- (d) Mix and place neat cement grout in accordance with Subarticles 1003-5, 1003-6 and 1003-7 of the *2018 Standard Specifications*. Measure grout temperature, density and flow during grouting with at least the same frequency grout cubes are made for compressive strength. Perform density

and flow field tests in the presence of the Engineer in accordance with American National Standards Institute/American Petroleum Institute Recommended Practice 13B-1 (Section 4, Mud Balance) and ASTM C939 (Flow Cone), respectively.

Install helical anchors in accordance with the accepted submittals and Anchor Manufacturer's instructions. Measure torque during installation and do not exceed the torsional strength rating of the helical anchor. Attain the minimum required installation torque and penetration before terminating anchor installation. When replacing a helical anchor, embed last helix of the replacement anchor at least 3 helix plate diameters past the location of the first helix of the previous anchor.

(4) Anchor Testing

Proof test and lock-off anchors in accordance with the accepted submittals and Article 6.5.5 of the *AASHTO LRFD Bridge Construction Specifications* except for the acceptance criteria in Article 6.5.5.5. For the AASHTO LRFD specifications, "ground anchor" refers to a ground or helical anchor and "tendon" refers to a bar, strand or shaft.

(a) Anchor Acceptance

Anchor acceptance is based in part on the following criteria.

- (i) For ground and helical anchors, total movement is less than 0.04 inches between the 1 and 10 minute readings or less than 0.08 inches between the 6 and 60 minute readings.
- (ii) For ground anchors, total movement at maximum test load exceeds 80% of the theoretical elastic elongation of the unbonded length.

(b) Anchor Test Results

Submit PDF files of anchor test records including movement versus load plots for each load increment within 24 hours of completing each row of anchors. The Engineer will review the test records to determine if the anchors are acceptable.

If the Engineer determines an anchor is unacceptable, revise the anchor design or installation methods. Submit a revised anchored shoring design for acceptance and provide an acceptable anchor with the revised design or installation methods. If required, replace the anchor or provide additional anchors with the revised design or installation methods.

(C) Temporary Wall Installation

Excavate as necessary for temporary walls in accordance with the plans and accepted submittals. If applicable, install foundations located in the reinforced zone before placing shoring backfill or reinforcement unless otherwise approved. Notify the Engineer when

foundation excavation is complete. Do not place shoring backfill or reinforcement until excavation dimensions and foundation material are approved.

Erect welded wire facing so the wall position is as shown in the plans and accepted submittals. Set welded wire facing adjacent to each other in the horizontal and vertical direction to completely cover the wall face with facing. Stagger welded wire facing to create a running bond by centering facing over joints in the row below.

Attach geostrip reinforcement to welded wire facing and wrap geotextile reinforcement and retention geotextiles behind welded wire facing as shown in the plans and accepted submittals. Cover geotextiles with at least 3" of shoring backfill. Overlap adjacent geotextile reinforcement and retention and separation geotextiles at least 18 inches with seams oriented perpendicular to the wall face. Hold geotextiles in place with wire staples or anchor pins as needed.

Place reinforcement within 3 inches of locations shown in the plans and accepted submittals. Before placing shoring backfill, pull geosynthetic reinforcement taut so it is in tension and free of kinks, folds, wrinkles or creases. Install reinforcement with the direction shown in the plans and accepted submittals. For temporary wire walls with separate reinforcement and facing components, attach welded wire grid or metallic strip reinforcement to welded wire facing as shown in the accepted submittals. Do not splice or overlap reinforcement so seams are parallel to the wall face. Contact the Engineer when unanticipated existing or future obstructions such as foundations, pavements, pipes, inlets or utilities will interfere with reinforcement.

Place shoring backfill in the reinforced zone in 8 to 10 inch thick lifts. Compact A-2-4 soil and Class II, Type 1 and Class III select material in accordance with Subarticle 235-3(C) of the *2018 Standard Specifications*. Use only hand operated compaction equipment to compact backfill within 3 feet of welded wire facing. At a distance greater than 3 feet, compact shoring backfill with at least 4 passes of an 8 to 10 ton vibratory roller in a direction parallel to the wall face. Smooth wheeled or rubber tired rollers are also acceptable for compacting backfill. Do not use sheepsfoot, grid rollers or other types of compaction equipment with feet. Do not displace or damage reinforcement when placing and compacting shoring backfill. End dumping directly on geosynthetics is not permitted. Do not operate heavy equipment on reinforcement until it is covered with at least 8 inches of shoring backfill. Replace any damaged reinforcement to the satisfaction of the Engineer.

Backfill for temporary walls outside the reinforced zone in accordance with Article 410-8 of the *2018 Standard Specifications*. Bench temporary walls into the sides of excavations where applicable. For temporary geosynthetic walls with top of wall within 5 feet of finished grade, remove top facing and incorporate top reinforcement layer into fill when placing fill in front of wall. Temporary walls remain in place permanently unless otherwise required.

Measurement and Payment

Temporary Shoring will be measured and paid in square feet. Temporary walls will be measured as the square feet of exposed wall face area. Cantilever, braced or anchored shoring will be

measured as the square feet of exposed shoring face area with the shoring height equal to the difference between the top and bottom of shoring elevations. Define “top of shoring” as where the grade intersects the back of sheet piles or H-piles and timber lagging. Define “bottom of shoring” as where the grade intersects front of sheet piles or H-piles and timber lagging. No measurement will be made for any embedment, shoring extension above top of shoring or pavement thickness above temporary walls.

The contract unit price for *Temporary Shoring* will be full compensation for providing shoring designs, submittals and materials, excavating, backfilling, hauling and removing excavated materials and supplying all labor, tools, equipment and incidentals necessary to construct temporary shoring.

No payment will be made for temporary shoring not shown in the plans or required by the Engineer including shoring for OSHA reasons or the Contractor’s convenience. No value engineering proposals will be accepted based solely on revising or eliminating shoring locations shown in the plans or estimated quantities shown in the bid item sheets as a result of actual field measurements or site conditions.

PCB will be measured and paid in accordance with Section 1170 of the *2018 Standard Specifications*. No additional payment will be made for anchoring PCB for temporary shoring. Costs for anchoring PCB will be incidental to temporary shoring.

Temporary guardrail will be measured and paid for in accordance with Section 862 of the *2018 Standard Specifications*.

Payment will be made under:

Pay Item	Pay Unit
Temporary Shoring	Square Foot

MATERIAL AND EQUIPMENT STORAGE & PARKING OF PERSONAL VEHICLES:

11-17-21(Rev. 8-16-22)

1101

SP11 R03

Revise the *2018 Standard Specifications* as follows:

Page 11-2, Article 1101-8 MATERIAL AND EQUIPMENT STORAGE, line 35-38, delete and replace with the following:

When work is not in progress, keep all personnel, equipment, machinery, tools, construction debris, materials and supplies away from active travel lanes that meets Table 1101-1.

TABLE 1101-1	
MATERIAL AND EQUIPMENT STORAGE FROM ACTIVE TRAVEL LANES	
Posted Speed Limit (mph)	Distance (ft)
40 or less	≥ 18
45-50	≥ 28
55	≥ 32
60 or higher	≥ 40

When vehicles, equipment and materials are protected by concrete barrier or guardrail, they shall be offset at least 5 feet from the barrier or guardrail.

Page 11-2, Article 1101-9 PARKING OF PERSONAL VEHICLES, line 40-41, delete and replace with the following:

Provide staging areas for personal vehicle parking in accordance with Article 1101-8 or as directed by the Engineer before use.

WORK ZONE INSTALLER:

(7-20-21)(Rev. 8-16-22)

1101, 1150

SP11 R04

Provide the service of at least one qualified work zone installer during the setup, installation, and removal of temporary traffic control within the highway right of way. The qualified work zone installer shall serve as crew leader and shall be on site and directing the installation and removal of temporary traffic control. If multiple temporary traffic control installations or removals are occurring simultaneously, then each shall have a qualified work zone installer.

The work zone installer shall be qualified by an NCDOT approved training agency or other NCDOT approved training provider in the safe and competent set up of temporary traffic control. For a complete listing of approved training agencies, see the Work Zone Safety Training webpage.

A work zone supervisor, in accordance with Article 1101-13 of the *Standard Specifications*, may fulfill the role of the work zone installer during the setup, installation, and removal of temporary traffic control within the highway right of way provided they are on site and directing the installation and removal of temporary traffic control.

All other individuals participating in the setup, installation, and removal of temporary traffic control within the highway right of way shall be certified as a qualified flagger in accordance with Article 1150-3 of the *Standard Specifications*, even if flagging is not being performed as part of the traffic control.

Provide the name and contact information of all qualified work zone installers to the Engineer prior to or at the preconstruction conference. Additionally, provide a qualification statement that all other individuals participating in the setup, installation, and removal of temporary traffic control are qualified flaggers that have been properly trained through an NCDOT approved training agency or other NCDOT approved training provider.

All certification records for qualified work zone installers and flaggers shall be uploaded by the approved training agency or other NCDOT approved training provider to the Department's Work Zone Education Verification App (WZ-EVA) prior to the qualified work zone installer or flagger performing any traffic control duties on the project. For more information about WZ-EVA, see the Work Zone Safety Training webpage.

PORTABLE CHANGEABLE MESSAGE SIGNS:

(9-20-22)(Rev. 11-15-22)

1089, 1120

SP11 R10

Revise the *2018 Standard Specifications* as follows:

Page 10-197, Subarticle 1089-7(D) Controller, line 16, add the following after the third sentence of the first paragraph:

Change the controller password from the factory default and periodically change the controller password to deter unauthorized programming of the controller.

Page 10-197, Subarticle 1089-7(D) Controller, lines 16-19, replace the fourth sentence of the first paragraph with the following:

The password system is recommended to include at least two levels of security such that operators at one level may only change message sequences displayed using preprogrammed sequences and operators at a higher level may create and store messages or message sequences.

Page 10-197, Subarticle 1089-7(D) Controller, line 24 replace the sentence with the following:

The controller shall be stored in a locked, weather and vandal resistant box when not in use and after changes to the messages are made.

Page 11-8, Article 1120-3 CONSTRUCTION METHODS, lines 26-32, replace the second paragraph with the following:

Provide an experienced operator for the portable changeable message sign during periods of operation to ensure that the messages displayed on the sign panel are in accordance with the plans and Subarticle 1089-7(D). Change the controller password from the factory default and periodically change the controller password to deter unauthorized programming of the controller. Using two levels of password security is recommended such that operators at one level may only change message sequences displayed using preprogrammed sequences and operators at a higher level may create and store messages or message sequences. Lock the controller in a weather and vandal resistant box when not in use and after changes to the messages are made.

LAW ENFORCEMENT:

(6-21-22)(Rev. 11-15-22)

1190

SP11 R30

Revise the *2018 Standard Specifications* as follows:

Page 11-19, Article 1190-1 DESCRIPTION, lines 4-5, replace the paragraph with the following:

Furnish Law Enforcement Officers and official Law Enforcement vehicles to direct traffic in accordance with the contract.

Page 11-19, Article 1190-2 CONSTRUCTION METHODS, lines 7-10, replace the first and second paragraph with the following:

Use off duty uniformed Law Enforcement Officers and official Law Enforcement vehicles equipped with blue lights to direct or control traffic as required by the plans or by the Engineer.

Law Enforcement vehicles shall not be parked within the buffer space on any roadway. Law Enforcement vehicles shall not be used to close or block an active travel lane on multilane roadways with a posted speed limit of 45 MPH or higher, except as allowed during rolling roadblock operations as shown in the *Roadway Standard Drawings* or while responding to an emergency.

Page 11-19, Article 1190-3 MEASUREMENT AND PAYMENT, lines 14-15, replace the second sentence of the first paragraph with the following:

There will be no direct payment for official Law Enforcement vehicles as they are considered incidental to the pay item.

EXTRUDED THERMOPLASTIC PAVEMENT MARKING THICKNESS:

3-19-19 (Rev. 6-21-22)

1205

SP12 R05

Revise the *2018 Standard Specifications* as follows:

Page 12-6, Subarticle 1205-4(A)(1) General, lines 5-8, delete the second sentence and replace with the following:

Use application equipment that provides multiple width settings ranging from 4 inches to 12 inches and multiple thickness settings to achieve the required thickness above the surface of the pavement as shown in Table 1205-3.

Page 12-7, Table 1205-3, THICKNESS REQUIREMENTS FOR THERMOPLASTIC, replace with the following:

TABLE 1205-3 MINIMUM THICKNESS REQUIREMENTS FOR THERMOPLASTIC	
Thickness	Location
240 mils	In-lane and shoulder-transverse pavement markings (rumble strips). May be placed in 2 passes.
90 mils	Center lines, skip lines, transverse bands, mini-skip lines, characters, bike lane symbols, crosswalk lines, edge lines, gore lines, diagonals, and arrow symbols

PERMANENT SEEDING AND MULCHING:

(7-1-95)

1660

SP16 R02

The Department desires that permanent seeding and mulching be established on this project as soon as practical after slopes or portions of slopes have been graded. As an incentive to obtain an early stand of vegetation on this project, the Contractor's attention is called to the following:

For all permanent seeding and mulching that is satisfactorily completed in accordance with the requirements of Section 1660 in the *2018 Standard Specifications* and within the following percentages of elapsed contract times, an additional payment will be made to the Contractor as an incentive additive. The incentive additive will be determined by multiplying the number of acres of seeding and mulching satisfactorily completed times the contract unit bid price per acre for Seeding and Mulching times the appropriate percentage additive.

Percentage of Elapsed Contract Time	Percentage Additive
0% - 30%	30%
30.01% - 50%	15%

Percentage of elapsed contract time is defined as the number of calendar days from the date of availability of the contract to the date the permanent seeding and mulching is acceptably completed divided by the total original contract time.

STANDARD SPECIAL PROVISION
AVAILABILITY OF FUNDS – TERMINATION OF CONTRACTS

(5-20-08)

Z-2

General Statute 143C-6-11. (h) Highway Appropriation is hereby incorporated verbatim in this contract as follows:

(h) Amounts Encumbered. – Transportation project appropriations may be encumbered in the amount of allotments made to the Department of Transportation by the Director for the estimated payments for transportation project contract work to be performed in the appropriation fiscal year. The allotments shall be multiyear allotments and shall be based on estimated revenues and shall be subject to the maximum contract authority contained in *General Statute 143C-6-11(c)*. Payment for transportation project work performed pursuant to contract in any fiscal year other than the current fiscal year is subject to appropriations by the General Assembly. Transportation project contracts shall contain a schedule of estimated completion progress, and any acceleration of this progress shall be subject to the approval of the Department of Transportation provided funds are available. The State reserves the right to terminate or suspend any transportation project contract, and any transportation project contract shall be so terminated or suspended if funds will not be available for payment of the work to be performed during that fiscal year pursuant to the contract. In the event of termination of any contract, the contractor shall be given a written notice of termination at least 60 days before completion of scheduled work for which funds are available. In the event of termination, the contractor shall be paid for the work already performed in accordance with the contract specifications.

Payment will be made on any contract terminated pursuant to the special provision in accordance with Subarticle 108-13(D) of the *2018 Standard Specifications*.

STANDARD SPECIAL PROVISION
NCDOT GENERAL SEED SPECIFICATION FOR SEED QUALITY

(5-17-11)

Z-3

Seed shall be sampled and tested by the North Carolina Department of Agriculture and Consumer Services, Seed Testing Laboratory. When said samples are collected, the vendor shall supply an independent laboratory report for each lot to be tested. Results from seed so sampled shall be final. Seed not meeting the specifications shall be rejected by the Department of Transportation and shall not be delivered to North Carolina Department of Transportation warehouses. If seed has been delivered it shall be available for pickup and replacement at the supplier's expense.

Any re-labeling required by the North Carolina Department of Agriculture and Consumer Services, Seed Testing Laboratory, that would cause the label to reflect as otherwise specified herein shall be rejected by the North Carolina Department of Transportation.

Seed shall be free from seeds of the noxious weeds Johnsongrass, Balloonvine, Jimsonweed, Witchweed, Itchgrass, Serrated Tussock, Showy Crotalaria, Smooth Crotalaria, Sicklepod, Sandbur, Wild Onion, and Wild Garlic. Seed shall not be labeled with the above weed species on the seed analysis label. Tolerances as applied by the Association of Official Seed Analysts will NOT be allowed for the above noxious weeds except for Wild Onion and Wild Garlic.

Tolerances established by the Association of Official Seed Analysts will generally be recognized. However, for the purpose of figuring pure live seed, the found pure seed and found germination percentages as reported by the North Carolina Department of Agriculture and Consumer Services, Seed Testing Laboratory will be used. Allowances, as established by the NCDOT, will be recognized for minimum pure live seed as listed on the following pages.

The specifications for restricted noxious weed seed refers to the number per pound as follows:

<u>Restricted Noxious Weed</u>	<u>Limitations per Lb. Of Seed</u>	<u>Restricted Noxious Weed</u>	<u>Limitations per Lb. of Seed</u>
Blessed Thistle	4 seeds	Cornflower (Ragged Robin)	27 seeds
Cocklebur	4 seeds	Texas Panicum	27 seeds
Spurred Anoda	4 seeds	Bracted Plantain	54 seeds
Velvetleaf	4 seeds	Buckhorn Plantain	54 seeds
Morning-glory	8 seeds	Broadleaf Dock	54 seeds
Corn Cockle	10 seeds	Curly Dock	54 seeds
Wild Radish	12 seeds	Dodder	54 seeds
Purple Nutsedge	27 seeds	Giant Foxtail	54 seeds
Yellow Nutsedge	27 seeds	Horsenettle	54 seeds
Canada Thistle	27 seeds	Quackgrass	54 seeds
Field Bindweed	27 seeds	Wild Mustard	54 seeds
Hedge Bindweed	27 seeds		

Seed of Pensacola Bahiagrass shall not contain more than 7% inert matter, Kentucky Bluegrass, Centipede and Fine or Hard Fescue shall not contain more than 5% inert matter whereas a maximum of 2% inert matter will be allowed on all other kinds of seed. In addition, all seed shall

not contain more than 2% other crop seed nor more than 1% total weed seed. The germination rate as tested by the North Carolina Department of Agriculture shall not fall below 70%, which includes both dormant and hard seed. Seed shall be labeled with not more than 7%, 5% or 2% inert matter (according to above specifications), 2% other crop seed and 1% total weed seed.

Exceptions may be made for minimum pure live seed allowances when cases of seed variety shortages are verified. Pure live seed percentages will be applied in a verified shortage situation. Those purchase orders of deficient seed lots will be credited with the percentage that the seed is deficient.

FURTHER SPECIFICATIONS FOR EACH SEED GROUP ARE GIVEN BELOW:

Minimum 85% pure live seed; maximum 1% total weed seed; maximum 2% total other crop seed; maximum 144 restricted noxious weed seed per pound. Seed less than 83% pure live seed will not be approved.

Sericea Lespedeza
Oats (seeds)

Minimum 80% pure live seed; maximum 1% total weed seed; maximum 2% total other crop; maximum 144 restricted noxious weed seed per pound. Seed less than 78% pure live seed will not be approved.

Tall Fescue (all approved varieties)	Bermudagrass
Kobe Lespedeza	Browntop Millet
Korean Lespedeza	German Millet – Strain R
Weeping Lovegrass	Clover – Red/White/Crimson
Carpetgrass	

Minimum 78% pure live seed; maximum 1% total weed seed; maximum 2% total other crop seed; maximum 144 restricted noxious weed seed per pound. Seed less than 76% pure live seed will not be approved.

Common or Sweet Sundangrass

Minimum 76% pure live seed; maximum 1% total weed seed; maximum 2% total other crop seed; maximum 144 restricted noxious weed seed per pound. Seed less than 74% pure live seed will not be approved.

Rye (grain; all varieties)
Kentucky Bluegrass (all approved varieties)
Hard Fescue (all approved varieties)
Shrub (bicolor) Lespedeza

Minimum 70% pure live seed; maximum 1% total weed seed; maximum 2% total other crop seed; maximum 144 noxious weed seed per pound. Seed less than 70% pure live seed will not be approved.

Centipedegrass	Japanese Millet
Crownvetch	Reed Canary Grass
Pensacola Bahiagrass	Zoysia
Creeping Red Fescue	

Minimum 70% pure live seed; maximum 1% total weed seed; maximum 2% total other crop seed; maximum 5% inert matter; maximum 144 restricted noxious weed seed per pound.

Barnyard Grass
Big Bluestem
Little Bluestem
Bristly Locust
Birdsfoot Trefoil
Indiangrass
Orchardgrass
Switchgrass
Yellow Blossom Sweet Clover

STANDARD SPECIAL PROVISION**ERRATA**

(10-16-18) (Rev. 6-20-23)

Z-4

Revise the *2018 Standard Specifications* as follows:

Division 1

Page 1-1, Article 101-2 Abbreviations, line 13, replace " American National Standards Institute, Inc." with "American National Standards Institute".

Page 1-1, Article 101-2 Abbreviations, line 32, replace "Equivalent Single Axis Load" with "Equivalent Single Axle Load".

Page 1-16, Subarticle 102-9(A) General, line 26, replace "10 U.S.C. 2304(g)" with "10 U.S.C. 3205".

Page 1-43, Article 104-13 RECYCLED PRODUCTS OR SOLID WASTE MATERIALS, line 4, replace "104-13(B)(2)" with "104-13(B)".

Page 1-52, Article 106-1 RECYCLED PRODUCTS OR SOLID WASTE MATERIALS, line 25, replace "13 NCAC 7CF.0101(a)(99)" with "29 CFR 1910.1200".

Page 1-79, Article 109-1 MEASUREMENT AND PAYMENT, Test Method prior to line 34, replace "AASHTO M 32" with "AASHTO M 336".

Division 2

Page 2-5, Article 210-2 CONSTRUCTION METHODS, line 21, replace " NCGS §§ 130A-444 to -452" with "NCGS §§ 130A-444 to -453".

Page 2-13, Article 225-2 EROSION CONTROL REQUIREMENTS, line 17, replace "the Sedimentation and Pollution Control Act" with "Article 107-12".

Page 2-20, Subarticle 230-4(B)(3) Reclamation Plan, line 12, replace " Department's borrow and waste site reclamation procedures for contracted projects" with "Department's *Borrow Waste and Staging Site Reclamation Procedures for Contract Projects*".

Page 2-25, Subarticle 235-3(E) Surcharges and Waiting Periods, line 21 and 27, delete "Department's Materials and Tests Unit."

Page 2-27, Article 240-4 MEASUREMENT AND PAYMENT, line 23, replace "Section 225" with "Article 225-7".

Page 2-30, Article 275-4 MEASUREMENT AND PAYMENT, line 33, replace "Section 815" with "Article 815-4".

Division 4

Page 4-18, Subarticle 411-5(C)(3) Coring, line 11, replace "in accordance with ASTM D5079" with "with methods acceptable to the Engineer".

Page 4-50, Article 430-2 MATERIALS, prior to line 15, replace Section “1080-9” with “1080-7”.

Page 4-53, Article 440-2 MATERIALS, prior to line 6, replace Section “1080-9” with “1080-7”.

Page 4-58, Article 442-2 MATERIALS, prior to line 15, replace Section “1080-6” with “1080-12”.

Page 4-59, Subarticle 442-7(A) Blast Cleaning, line 36, replace Article “1080-6” with “1080-12”.

Page 4-76, Article 454-2 MATERIALS, prior to line 24, replace Section “815-2” with “1044”.

Page 4-79, Article 455-2 MATERIALS, prior to line 21, replace Section “815” with “1044”.

Page 4-80, Subarticle 455-3(B) Precast Gravity Wall Designs, line 23 and lines 25-26, replace “AASHTO LRFD specifications” with “*AASHTO LRFD Bridge Design Specifications*”.

Page 4-84, Article 458-5 MEASUREMENT AND PAYMENT, line 31, replace article number “454-1” with “458-1”.

Division 6

Page 6-7, Article 609-1 DESCRIPTION, line 29, replace article number “609-10” with “609-9”.

Page 6-10, Subarticle 609-6(C) Control Charts, line 17, replace Section number “7021” with “7.20.1”.

Page 6-13, Article 609-9 QUALITY ASSURANCE, line 31, replace Section number “7.60” with “7.6”.

Page 6-26, Subarticle 610-13(A)(1) Acceptance for New Construction, line 31, replace Table number “610-7” with “610-8”.

Page 6-29, Subarticle 610-13(B) North Carolina Hearne Straightedge, line 32, replace Table number “610-8” with “610-9”.

Page 6-31, Article 610-14 DENSITY ACCEPTANCE, Specified Density prior to line 30 and line 32, replace Table number “610-6” with “610-7”.

Page 6-37, Article 650-5 CONSTRUCTION METHODS, line 10, replace Section number “9.5(E)” with “9.5.1(E)”.

Page 6-44, Subarticle 660-8(B) Asphalt Mat and Seal, line 40, replace Subarticle number “660-8(A)” with “660-8(C)”.

Page 6-44, Subarticle 660-8(B) Asphalt Mat and Seal, line 42, replace Subarticle number “660-8(C)” with “660-8(A)”.

Division 7

Page 7-11, Subarticle 700-15(E) Compressive Strength, line 5, replace “AASHTO T 23” with “AASHTO R 100”.

Page 7-24, Article 723-4 Very High Early Strength Concrete for Concrete Pavement Repair, line 4, replace “AASHTO T126” with “AASHTO R 39”.

Page 7-24, Article 723-5 MEASUREMENT AND PAYMENT, line 34, replace "Section 225" with “Article 225-7”.

Page 7-24, Article 723-5 MEASUREMENT AND PAYMENT, line 36, replace "Section 270" with “Article 270-4”.

Page 7-27, Article 725-1 MEASUREMENT AND PAYMENT, line 4, replace article number “725-1” with “724-4”.

Page 7-28, Article 725-1 MEASUREMENT AND PAYMENT, line 10, replace article number “725-1” with “725-3”.

Division 8

Page 8-11, Article 815-1 MATERIALS, after line 35, replace “1080-12” with “1080-10”.

Page 8-13, Article 816-1 MATERIALS, after line 28, replace “1080-12” with “1080-10”.

Page 8-17, Article 825-1 Description, line 5, delete “853” and “855”.

Division 10

Page 10-2, Subarticle 1000-3(B) Air Entrainment, line 33, replace “Chase” with “Chace”.

Page 10-4, Subarticle 1000-4(A) Composition and Design, after line 17, replace “T23” with “R100”.

Page 10-4, Subarticle 1000-4(B) Air Entrainment, line 31 and 33, replace “Chase” with “Chace”.

Page 10-4, Subarticle 1000-4(C) Strength of Concrete, line 39 and 41, replace “T 23” with “R 100”.

Page 10-15, Subarticle 1000-11(B) Mixing Time for Central Mixed Concrete, after line 35, replace “T 23” with “R 100”.

Page 10-22, Article 1003-3 COMPOSITION AND DESIGN, line 9, replace “Engineer” with “engineer”.

Page 10-23, Article 1003-4 GROUT REQUIREMENTS, line 16 and 18, replace “T 23” with “R 100”.

Page 10-26, Article 1005-4 TESTING, after line 26, replace “1014-2€(6)” with “1014-2€(6)” in C. of Table 1005-1 footnote and replace “Lightweight^B” with “Lightweight^C”.

Page 10-29, Subarticle 1012-1(B)(4) Flat and Elongated Pieces, line 44, delete “SF9.5A”

Page 10-36, Subarticle 1012-2(E) Toughness (Resistance to Abrasion), line 31, replace “course” with “coarse”.

Page 10-37, Article 1012-4, LIGHTWEIGHT AGGREGATE, line 4, replace Table number “1012-8” with “1012-5”.

Page 10-48, Subarticle 1020-10(A) Mineral Fibers, line 27, replace “Table 1012-5” with “Table 1020-2”.

Page 10-52, Article 1024-5 FLY ASH, line 12, replace “Table 2” with “Table 3”.

Page 10-60, Subarticle 1032-6(F) Joint Materials, line 15, replace “AASHTO M 198” with “ASTM C990” and delete “Type B”.

Page 10-61, Article 1034-3 CONCRETE SEWER PIPE, line 33, replace “AASHTO M 198” with “ASTM C990” and delete “Type A or B”.

Page 10-64, Article 1040-1 BRICK, line 12, replace “ASTM C62” with “ASTM C62 or ASTM C216”.

Page 10-67, Article 1044-7 CORRUGATED PLASTIC PIPE AND FITTINGS, line 24, replace “AASHTO M 294 for heavy duty tubing” with “Article 1032-7 and AASHTO M 252”.

Page 10-68, Subarticle 1046-3(D) Offset Blocks, lines 30-32, delete “Before beginning the installation of recycled offset block, submit the FHWA acceptance letter for each type of block to the Engineer for approval.”

Page 10-69, Subarticle 1046-3(D) Offset Blocks, before line 1, replace “WIRE DIAMETER” with “COMPOSITE OFFSET BLOCKS” as the title of Table 1046-1, delete “Testing” property and associated requirement from Table 1046-1, and replace “Approval” requirement of “Approved for use by the FHWA” with “Approved for use on the NCDOT APL” in Table 1046-1.

Page 10-80, Article 1060-2 FERTILIZER, line 18, replace “North Carolina Fertilizer Law” with “North Carolina Commercial Fertilizer Law”.

Page 10-83, Article 1060-9 WATER, line 9, replace “15 NCAC 2B.0200” with “15A NCAC 02B.0200”.

Page 10-86, Article 1070-3 COLD DRAWN STEEL WIRE AND WIRE REINFORCEMENT, line 23 and 25, replace “M 32” and “M 55” with “M 336”.

Page 10-87, Article 1070-6 DOWELS AND TIE BARS FOR PORTLAND CEMENT CONCRETE PAVEMENT, line 17, replace “AASHTO M 32” with “AASHTO M 336”.

Page 10-88, Subarticle 1070-7(D) Handling, Storage and Transportation, line 40, replace “Section” with “Subarticle”.

Page 10-89, Article 1070-8 SPIRAL COLUMN REINFORCING STEEL, line 21, replace “AASHTO M 32” with “AASHTO M 336”.

Page 10-91, Article 1072-3 BEARING PLATE ASSEMBLIES, line 44, replace “Article 1080-9” with “Article 1080-7”.

Page 10-92, Subarticle 1072-5(A) General, after line 30, replace “SAMPLING REQUIREMENTS FOR HIGH STRENGTH BOLTS, NUTS AND WASHERS” with “SAMPLING REQUIREMENTS FOR HIGH STRENGTH BOLTS, NUTS AND WASHERS TO INCLUDE DIRECT TENSION INDICATORS” as the title of Table 1072-1.

Page 10-95, Subarticle 1072-5(D)(7)(a) Mill Test Report(s), line 18, replace title with “Mill Test Report(s) (MTR)”.

Page 10-95, Subarticle 1072-5(D)(7)(b) Manufacturer Certified Test Report(s), line 24, replace title with “Manufacturer Certified Test Report(s) (MCTR)”.

Page 10-96, Subarticle 1072-5(D)(7)(c) Distributor Certified Test Report(s), line 1, replace title with “Distributor Certified Test Report(s) (DCTR)”.

Page 10-98, Subarticle 1072-5(F) Galvanized High Strength Bolts, Nuts and Washers, line 11, replace “Article 1080-9” with “Article 1080-7”.

Page 10-98, Subarticle 1072-5(F) Galvanized High Strength Bolts, Nuts and Washers, line 11, replace “Article 1080-9” with “Article 1080-7”.

Page 10-111, Subarticle 1072-18(B) General, line 24, replace “Structural Welding Code-Reinforcing Steel” with “Structural Welding Code-Steel Reinforcing Bars”.

Page 10-117, Article 1074-1 WELDING, lines 21-22, replace “Structural Welding Code-Reinforcing Steel” with “Structural Welding Code-Steel Reinforcing Bars”.

Page 10-119, Article 1074-7(B) Gray Iron Castings, line 16, replace “M306” with “AASHTO M 306”.

Page 10-121, Article 1076-7, REPAIR OF GALVANIZING, line 8, replace article number “1080-9” with “1080-7”.

Page 10-125, Subarticle 1077-5(B) Testing, line 31, replace “T 23” with “R 100”.

Page 10-131, Subarticle 1078-4(A) Composition and Design, after line 23, in Table 1078-2 replace “T 23” with “R 100”.

Page 10-135, Subarticle 1078-4(J)(2) Mixing Time for Central Mixed Concrete, line 46, replace “Table 1078-2” with “Table 1078-3”

Page 10-136, Subarticle 1078-4(J)(2) Mixing Time for Central Mixed Concrete, after line 17, replace “T23” with “R100”.

Page 10-153, Subarticle 1079-1 PREFORMED BEARING PADS, line 8, replace “MIL-C882-D” with “MIL-C-882-E”.

Page 10-154, Subarticle 1079-2(A) General, line 6, delete “and 1079-2(E)”.

Page 10-156, Article 1080-5 SELF-CURING INORGANIC ZINC PAINT, line 8, replace “AASHTO M 252” with “AASHTO M 300”.

Page 10-156, Article 1080-5 SELF-CURING INORGANIC ZINC PAINT, line 20, replace “AASHTO M 253” with “AASHTO M 300”.

Page 10-156, Subarticle 1080-9(A) Composition, line 40, replace “Tables 1080-7 through 1080-14” with “Tables 1080-1 through 1080-3”.

Page 10-157, Subarticle 1080-9(B) Properties, line 5, replace “Tables 1080-7 through 1080-14” with “Tables 1080-1 through 1080-3”.

Page 10-157, Subarticle 1080-9(B) Properties, line 35, replace “Materials and Tests Standards CLS-P-1.0” with “*Structural Steel Shop Coatings Program*”.

Page 10-159, Subarticle 1080-9(E) Color Variation, Table 1080-1, replace “ASTM D1159” with “ASTM D1199”.

Page 10-159, Subarticle 1080-9(E) Color Variation, Table 1080-1, replace “NCDOT M&T P-10” with “ASTM D6280”.

Page 10-161, Subarticle 1080-9(E) Color Variation, Table 1080-3, replace “ASTM D13278” and “ASTM D3278”.

Page 10-161, Subarticle 1080-9(E) Color Variation, Table 1080-3, replace “NCDOT M&T P-10” and “Structural Steel Shop Coatings Program”.

Page 10-161, Subarticle 1080-9(E) Color Variation, Table 1080-3, add Test Method “ASTM D4400” for the Leneta Sag Test property in Table 1080-3.

Page 10-161, Subarticle 1080-9(E) Color Variation, Table 1080-3, add Test Method “ASTM D523” for the Gloss, Specular property in Table 1080-3.

Page 10-161, Subarticle 1080-9(E) Color Variation, Table 1080-3, replace Test Method “ASTM” with “ASTM E70” for the pH property in Table 1080-3.

Page 10-162, Article 1080-50 PAINT FOR VERTICAL MARKERS, line 1, replace article number “1080-50” with “1080-10”.

Page 10-162, Article 1080-61 EPOXY RESIN FOR REINFORCING STEEL, line 5, replace article number “1080-61” with “1080-11”.

Page 10-162, Article 1080-72 ABRASIVE MATERIALS FOR BLAST CLEANING STEEL, line 22, replace article number “1080-72” with “1080-12”.

Page 10-163, Article 1080-83 FIELD PERFORMANCE AND SERVICES, line 25, replace article number “1080-83” with “1080-13”.

Page 10-166, Subarticle 1081-1(E) Prequalification, line 24, replace “Value Management Unit” with “Product Evaluation Program”.

Page 10-168, Subarticle 1081-3(A) Physical Requirements, after line 25, replace “Subarticle 1081-4(B)” with “Subarticle 1081-3(B)” in Table 1081-2.

Page 10-168, Subarticle 1087-2(A) Paint Composition, lines 19-20, replace “Federal Specification TTP 1952F” with “Federal Specification TT-P-1952”.

Page 10-200, Subarticle 1090-1(C) Anchor Bolts, line 38, replace ASTM number “A325” with “F3125”.

Page 10-202, Subarticle 1091-3(F) Solid Wall HDPE Conduit, line 5, replace “, Table 1091-1, 1091-2 and 1091-3” with “and Table 1091-1”.

Page 10-208, Subarticle 1094-1(A) Breakaway or Simple Steel Beam Sign Supports, line 19, replace ASTM number “A325” with “F3125”.

Page 10-209, Subarticle 1094-1(D) Steel Square Tube Posts, line 10, replace ASTM number “A123” with “A653”.

Page 10-209, Subarticle 1094-1(E) Wood Supports, line 17, replace “Article 1082-2 and 1082-3” with “Section 1082”.

Page 10-212, Subarticle 1098-1(H) Electrical Service, line 21, replace “NEMA Type 3R” with “NEMA 3R”.

Page 10-212, Subarticle 1098-1(H) Electrical Service, line 36, replace “UL Standard 231” with “UL Standard UL-231”.

Page 10-212, Subarticle 1098-1(H) Electrical Service, line 37, replace “UL Standard 67” with “UL Standard UL-67”.

Page 10-224, Subarticle 1098-14(H)(1) Type I – Pedestrian Pushbutton Post, line 3, replace ASTM number “325” with “F3125”.

Page 10-224, Article 1098-16 CABINET BASE ADAPTER/EXTENDER, line 33, replace Section number “6.7” with “6.8”.

Division 14

Page 14-11, Subarticle 1401-2(B) Lowering Device, line 36, replace Military Specification “MIL-W-83420E” with “MIL-DTL-83420”.

Page 14-22, Article 1412-2 MATERIALS, line 29, replace UL Standard “1572” with “1598”.

Division 15

Page 15-6, Subarticle 1510-3(B) Testing and Sterilization, line 40, replace Section number “4.4.3” with “4.4”.

Page 15-14, Article 1525-2 MATERIALS, line 9, replace “AASHTO M 198” with “ASTM C990”.

Page 15-14, Article 1525-2 MATERIALS, lines 17-18, delete “in the Grout Production and Delivery provision”.

Page 15-19, Article 1550-2 MATERIALS, line 16, replace “*AASHTO LRFD Bridge Design Specifications*” with “*AASHTO LRFD Bridge Construction Specifications*”.

Division 16

Page 16-9, Article 1630-3 MEASUREMENT AND PAYMENT, line 7, replace "Section 225" with “Article 225-7”.

Page 16-9, Article 1630-3 MEASUREMENT AND PAYMENT, line 8, replace "Section 230" with “Article 230-5”.

Page 16-16, Article 1637-5 MEASUREMENT AND PAYMENT, line 17, replace "Section 310" with “Article 310-6”.

Division 17

Page 17-15, Article 1715-4 MEASUREMENT AND PAYMENT, lines 42-44, replace the second sentence with the following:

An example is an installation of a single 1.25 inch HDPE conduit would be paid as:

Directional Drill (1)(1.25") Linear Foot

Page 17-15, Subarticle 1715-3(E) Bore and Jack, line 5, replace article number “1540-4” with “1550-4”.

Page 17-15, Subarticle 1715-3(E) Bore and Jack, lines 10 & 11, replace "*NCDOT Policies and Procedures for Accommodating Utilities on Highway Rights of Way*" with “*NCDOT Utilities Accommodations Manual*”.

STANDARD SPECIAL PROVISION**PLANT AND PEST QUARANTINES****(Imported Fire Ant, Gypsy Moth, Witchweed, Emerald Ash Borer, Guava Root Knot Nematode, And Other Noxious Weeds)**

(3-18-03) (Rev. 5-21-19)

Z-04a

Within Quarantined Area

This project may be within a county regulated for plant and/or pests. If the project or any part of the Contractor's operations is located within a quarantined area, thoroughly clean all equipment prior to moving out of the quarantined area. Comply with federal/state regulations by obtaining a certificate or limited permit for any regulated article moving from the quarantined area.

Originating in a Quarantined County

Obtain a certificate or limited permit issued by the N.C. Department of Agriculture/United States Department of Agriculture. Have the certificate or limited permit accompany the article when it arrives at the project site.

Contact

Contact the N.C. Department of Agriculture/United States Department of Agriculture at 1-800-206-9333, 919-707-3730, or <https://www.ncagr.gov/plantindustry/Plant/quaran/table2.htm> to determine those specific project sites located in the quarantined area or for any regulated article used on this project originating in a quarantined county.

Regulated Articles Include

1. Soil, sand, gravel, compost, peat, humus, muck, and decomposed manure, separately or with other articles. This includes movement of articles listed above that may be associated with cut/waste, ditch pulling, and shoulder cutting.
2. Plants with roots including grass sod.
3. Plant crowns and roots.
4. Bulbs, corms, rhizomes, and tubers of ornamental plants.
5. Hay, straw, fodder, and plant litter of any kind.
6. Clearing and grubbing debris.
7. Used agricultural cultivating and harvesting equipment.
8. Used earth-moving equipment.
9. Any other products, articles, or means of conveyance, of any character, if determined by an inspector to present a hazard of spreading imported fire ant, gypsy moth, witchweed, emerald ash borer, guava root knot nematode, or other noxious weeds.

STANDARD SPECIAL PROVISION

MINIMUM WAGES

(7-21-09)

Z-5

FEDERAL: The Fair Labor Standards Act provides that with certain exceptions every employer shall pay wages at the rate of not less than SEVEN DOLLARS AND TWENTY FIVE CENTS (\$7.25) per hour.

STATE: The North Carolina Minimum Wage Act provides that every employer shall pay to each of his employees, wages at a rate of not less than SEVEN DOLLARS AND TWENTY FIVE CENTS (\$7.25) per hour.

The minimum wage paid to all skilled labor employed on this contract shall be SEVEN DOLLARS AND TWENTY FIVE CENTS (\$7.25) per hour.

The minimum wage paid to all intermediate labor employed on this contract shall be SEVEN DOLLARS AND TWENTY FIVE CENTS (\$7.25) per hour.

The minimum wage paid to all unskilled labor on this contract shall be SEVEN DOLLARS AND TWENTY FIVE CENTS (\$7.25) per hour.

This determination of the intent of the application of this act to the contract on this project is the responsibility of the Contractor.

The Contractor shall have no claim against the Department of Transportation for any changes in the minimum wage laws, Federal or State. It is the responsibility of the Contractor to keep fully informed of all Federal and State Laws affecting his contract.

STANDARD SPECIAL PROVISION**TITLE VI AND NONDISCRIMINATION:**

(6-28-77)(Rev 6/19/2018)

Z-6

Revise the *2018 Standard Specifications* as follows:

Replace Article 103-4(B) with the following:

The North Carolina Department of Transportation is committed to carrying out the U.S. Department of Transportation's policy of ensuring nondiscrimination in the award and administration of contracts.

The provisions of this section related to United States Department of Transportation (US DOT) Order 1050.2A, Title 49 Code of Federal Regulations (CFR) part 21, 23 United States Code (U.S.C.) 140 and 23 CFR part 200 (or 49 CFR 303, 49 U.S.C. 5332 or 49 U.S.C. 47123) are applicable to all North Carolina Department of Transportation (NCDOT) contracts and to all related subcontracts, material supply, engineering, architectural and other service contracts, regardless of dollar amount. Any Federal provision that is specifically required not specifically set forth is hereby incorporated by reference.

(1) **Title VI Assurances (USDOT Order 1050.2A, Appendix A)**

During the performance of this contract, the contractor, for itself, its assignees, and successors in interest (hereinafter referred to as the "contractor") agrees as follows:

(a) Compliance with Regulations

The contractor (hereinafter includes consultants) shall comply with the Acts and the Regulations relative to Nondiscrimination in Federally-assisted programs of the U.S. Department of Transportation, Federal Highway Administration (FHWA), as they may be amended from time to time, which are herein incorporated by reference and made a part of this contract.

(b) Nondiscrimination

The contractor, with regard to the work performed by it during the contract, shall not discriminate on the grounds of race, color, or national origin in the selection and retention of subcontractors, including procurements of materials and leases of equipment. The contractor shall not participate directly or indirectly in the discrimination prohibited by the Acts and the Regulations, including employment practices when the contract covers any activity, project, or program set forth in Appendix B of 49 CFR Part 21.

(c) Solicitations for Subcontractors, Including Procurements of Materials and Equipment

In all solicitations, either by competitive bidding, or negotiation made by the contractor for work to be performed under a subcontract, including procurements of materials, or leases of equipment, each potential subcontractor or supplier shall be notified by the contractor of the contractor's obligations under this contract and the Acts and the Regulations relative to Nondiscrimination on the grounds of race, color, or national origin.

(d) Information and Reports

The contractor shall provide all information and reports required by the Acts, the Regulations, and directives issued pursuant thereto and shall permit access to its books, records, accounts, other sources of information, and its facilities as may be determined by the Recipient or the FHWA to be pertinent to ascertain compliance with such Acts,

Regulations, and instructions. Where any information required of a contractor is in the exclusive possession of another who fails or refuses to furnish the information, the contractor shall so certify to the Recipient or the FHWA, as appropriate, and shall set forth what efforts it has made to obtain the information.

(e) Sanctions for Noncompliance:

In the event of a contractor's noncompliance with the Non-discrimination provisions of this contract, the Recipient will impose such contract sanctions as it and/or the FHWA may determine to be appropriate, including, but not limited to:

- (i) Withholding payments to the contractor under the contract until the contractor complies; and/or
- (ii) Cancelling, terminating, or suspending a contract, in whole or in part.

(f) Incorporation of Provisions

The contractor shall include the provisions of paragraphs (a) through (f) in every subcontract, including procurements of materials and leases of equipment, unless exempt by the Acts, the Regulations and directives issued pursuant thereto. The contractor shall take action with respect to any subcontract or procurement as the Recipient or the FHWA may direct as a means of enforcing such provisions including sanctions for noncompliance. Provided, that if the contractor becomes involved in, or is threatened with litigation by a subcontractor, or supplier because of such direction, the contractor may request the Recipient to enter into any litigation to protect the interests of the Recipient. In addition, the contractor may request the United States to enter into the litigation to protect the interests of the United States.

(2) **Title VI Nondiscrimination Program (23 CFR 200.5(p))**

The North Carolina Department of Transportation (NCDOT) has assured the USDOT that, as a condition to receiving federal financial assistance, NCDOT will comply with Title VI of the Civil Rights Act of 1964 and all requirements imposed by Title 49 CFR part 21 and related nondiscrimination authorities to ensure that no person shall, on the ground of race, color, national origin, limited English proficiency, sex, age, or disability (including religion/creed or income-level, where applicable), be excluded from participation in, be denied the benefits of, or be subjected to discrimination under any programs, activities, or services conducted or funded by NCDOT. Contractors and other organizations under contract or agreement with NCDOT must also comply with Title VI and related authorities, therefore:

(a) During the performance of this contract or agreement, contractors (e.g., subcontractors, consultants, vendors, prime contractors) are responsible for complying with NCDOT's Title VI Program. Contractors are not required to prepare or submit Title VI Programs. To comply with this section, the prime contractor shall:

1. Post NCDOT's Notice of Nondiscrimination and the Contractor's own Equal Employment Opportunity (EEO) Policy in conspicuous locations accessible to all employees, applicants and subcontractors on the jobsite.
2. Physically incorporate the required Title VI clauses into all subcontracts on federally-assisted and state-funded NCDOT projects, and ensure inclusion by subcontractors into all lower-tier subcontracts.
3. Required Solicitation Language. The Contractor shall include the following notification in all solicitations for bids and requests for work or material, regardless of funding source:

"The North Carolina Department of Transportation, in accordance with the provisions of Title VI of the Civil Rights Act of 1964 (78 Stat. 252, 42 US.C. §§ 2000d to 2000d-4) and the Regulations, hereby notifies all bidders that it will affirmatively ensure that any contract

entered into pursuant to this advertisement, disadvantaged business enterprises will be afforded full and fair opportunity to submit bids in response to this invitation and will not be discriminated against on the grounds of race, color, or national origin in consideration for an award. In accordance with other related nondiscrimination authorities, bidders and contractors will also not be discriminated against on the grounds of sex, age, disability, low-income level, creed/religion, or limited English proficiency in consideration for an award.”

4. Physically incorporate the FHWA-1273, in its entirety, into all subcontracts and subsequent lower tier subcontracts on Federal-aid highway construction contracts only.
 5. Provide language assistance services (i.e., written translation and oral interpretation), free of charge, to LEP employees and applicants. Contact NCDOT OCR for further assistance, if needed.
 6. For assistance with these Title VI requirements, contact the NCDOT Title VI Nondiscrimination Program at 1-800-522-0453.
- (b) Subrecipients (e.g. cities, counties, LGAs, planning organizations) may be required to prepare and submit a Title VI Plan to NCDOT, including Title VI Assurances and/or agreements. Subrecipients must also ensure compliance by their contractors and subrecipients with Title VI. (23 CFR 200.9(b)(7))
- (c) If reviewed or investigated by NCDOT, the contractor or subrecipient agrees to take affirmative action to correct any deficiencies found within a reasonable time period, not to exceed 90 calendar days, unless additional time is granted by NCDOT. (23 CFR 200.9(b)(15))
- (d) The Contractor is responsible for notifying subcontractors of NCDOT’s External Discrimination Complaints Process.
1. Applicability
Title VI and related laws protect participants and beneficiaries (e.g., members of the public and contractors) from discrimination by NCDOT employees, subrecipients and contractors, regardless of funding source.
 2. Eligibility
Any person—or class of persons—who believes he/she has been subjected to discrimination based on race, color, national origin, Limited English Proficiency (LEP), sex, age, or disability (and religion in the context of employment, aviation, or transit) may file a written complaint. The law also prohibits intimidation or retaliation of any sort.
 3. Time Limits and Filing Options
Complaints may be filed by the affected individual(s) or a representative and must be filed no later than 180 calendar days after the following:
 - (i) The date of the alleged act of discrimination; or
 - (ii) The date when the person(s) became aware of the alleged discrimination; or
 - (iii) Where there has been a continuing course of conduct, the date on which that conduct was discontinued or the latest instance of the conduct.Title VI and related discrimination complaints may be submitted to the following entities:
 - North Carolina Department of Transportation, Office of Civil Rights, Title VI Program, 1511 Mail Service Center, Raleigh, NC 27699-1511; toll free 1-800-522-0453
 - Federal Highway Administration, North Carolina Division Office, 310 New Bern Avenue, Suite 410, Raleigh, NC 27601, 919-747-7010

- US Department of Transportation, Departmental Office of Civil Rights, External Civil Rights Programs Division, 1200 New Jersey Avenue, SE, Washington, DC 20590; 202-366-4070
4. Format for Complaints
Complaints must be in writing and signed by the complainant(s) or a representative, and include the complainant's name, address, and telephone number. Complaints received by fax or e-mail will be acknowledged and processed. Allegations received by telephone will be reduced to writing and provided to the complainant for confirmation or revision before processing. Complaints will be accepted in other languages, including Braille.
 5. Discrimination Complaint Form
Contact NCDOT Civil Rights to receive a full copy of the Discrimination Complaint Form and procedures.
 6. Complaint Basis
Allegations must be based on issues involving race, color, national origin (LEP), sex, age, disability, or religion (in the context of employment, aviation or transit). "Basis" refers to the complainant's membership in a protected group category.

**TABLE 103-1
COMPLAINT BASIS**

Protected Categories	Definition	Examples	Applicable Nondiscrimination Authorities
Race and Ethnicity	An individual belonging to one of the accepted racial groups; or the perception, based usually on physical characteristics that a person is a member of a racial group	Black/African American, Hispanic/Latino, Asian, American Indian/Alaska Native, Native Hawaiian/Pacific Islander, White	Title VI of the Civil Rights Act of 1964; 49 CFR Part 21; 23 CFR 200; 49 U.S.C. 5332(b); 49 U.S.C. 47123. <i>(Executive Order 13166)</i>
Color	Color of skin, including shade of skin within a racial group	Black, White, brown, yellow, etc.	
National Origin (<i>Limited English Proficiency</i>)	Place of birth. Citizenship is not a factor. (<i>Discrimination based on language or a person's accent is also covered</i>)	Mexican, Cuban, Japanese, Vietnamese, Chinese	
Sex	Gender. The sex of an individual. <i>Note: Sex under this program does not include sexual orientation.</i>	Women and Men	1973 Federal-Aid Highway Act; 49 U.S.C. 5332(b); 49 U.S.C. 47123.
Age	Persons of any age	21-year-old person	Age Discrimination Act of 1975 49 U.S.C. 5332(b); 49 U.S.C. 47123.
Disability	Physical or mental impairment, permanent or temporary, or perceived.	Blind, alcoholic, para-amputee, epileptic, diabetic, arthritic	Section 504 of the Rehabilitation Act of 1973; Americans with Disabilities Act of 1990

<p>Religion (in the context of employment) <i>(Religion/ Creed in all aspects of any aviation or transit-related construction)</i></p>	<p>An individual belonging to a religious group; or the perception, based on distinguishable characteristics that a person is a member of a religious group. In practice, actions taken as a result of the moral and ethical beliefs as to what is right and wrong, which are sincerely held with the strength of traditional religious views. Note: Does not have to be associated with a recognized religious group or church; if an individual sincerely holds to the belief, it is a protected religious practice.</p>	<p>Muslim, Christian, Sikh, Hindu, etc.</p>	<p>Title VII of the Civil Rights Act of 1964; 23 CFR 230; FHWA-1273 Required Contract Provisions. <i>(49 U.S.C. 5332(b); 49 U.S.C. 47123)</i></p>
--	---	---	---

(3) Pertinent Nondiscrimination Authorities

During the performance of this contract, the contractor, for itself, its assignees, and successors in interest agrees to comply with the following non-discrimination statutes and authorities, including, but not limited to:

- (a) Title VI of the Civil Rights Act of 1964 (42 U.S.C. § 2000d et seq., 78 stat. 252), (prohibits discrimination on the basis of race, color, national origin); and 49 CFR Part 21.
- (b) The Uniform Relocation Assistance and Real Property Acquisition Policies Act of 1970, (42 U.S.C. § 4601), (prohibits unfair treatment of persons displaced or whose property has been acquired because of Federal or Federal-aid programs and projects);
- (c) Federal-Aid Highway Act of 1973, (23 U.S.C. § 324 et seq.), (prohibits discrimination on the basis of sex);
- (d) Section 504 of the Rehabilitation Act of 1973, (29 U.S.C. § 794 et seq.), as amended, (prohibits discrimination on the basis of disability) and 49 CFR Part 27;
- (e) The Age Discrimination Act of 1975, as amended, (42 U.S.C. § 6101 et seq.), (prohibits discrimination on the basis of age);
- (f) Airport and Airway Improvement Act of 1982, (49 USC § 471, Section 47123), as amended, (prohibits discrimination based on race, creed, color, national origin, or sex);
- (g) The Civil Rights Restoration Act of 1987, (PL 100-209), (Broadened the scope, coverage and applicability of Title VI of the Civil Rights Act of 1964, The Age Discrimination Act of 1975 and Section 504 of the Rehabilitation Act of 1973, by expanding the definition of the terms "programs or activities" to include all of the programs or activities of the Federal-aid recipients, sub-recipients and contractors, whether such programs or activities are Federally funded or not);
- (h) Titles II and III of the Americans with Disabilities Act, which prohibit discrimination on the basis of disability in the operation of public entities, public and private transportation systems, places of public accommodation, and certain testing entities (42 U.S.C. §§ 12131-12189) as implemented by Department of Transportation regulations at 49 C.F.R. parts 37 and 38;
- (i) The Federal Aviation Administration's Nondiscrimination statute (49 U.S.C. § 47123) (prohibits discrimination on the basis of race, color, national origin, and sex);
- (j) Executive Order 12898, Federal Actions to Address Environmental Justice in Minority Populations and Low-Income Populations, which ensures Nondiscrimination against minority populations by discouraging programs, policies, and activities with

- disproportionately high and adverse human health or environmental effects on minority and low-income populations;
- (k) Executive Order 13166, Improving Access to Services for Persons with Limited English Proficiency, and resulting agency guidance, national origin discrimination includes discrimination because of Limited English proficiency (LEP). To ensure compliance with Title VI, you must take reasonable steps to ensure that LEP persons have meaningful access to your programs (70 Fed. Reg. at 74087 to 74100);
 - (l) Title IX of the Education Amendments of 1972, as amended, which prohibits you from discriminating because of sex in education programs or activities (20 U.S.C. 1681 et seq).
 - (m) Title VII of the Civil Rights Act of 1964 (42 U.S.C. § 2000e et seq., Pub. L. 88-352), (prohibits employment discrimination on the basis of race, color, religion, sex, or national origin).
- (4) **Additional Title VI Assurances**

***The following Title VI Assurances (Appendices B, C and D) shall apply, as applicable*

- (a) Clauses for Deeds Transferring United States Property (1050.2A, Appendix B)
The following clauses will be included in deeds effecting or recording the transfer of real property, structures, or improvements thereon, or granting interest therein from the United States pursuant to the provisions of Assurance 4.

NOW, THEREFORE, the U.S. Department of Transportation as authorized by law and upon the condition that the North Carolina Department of Transportation (NCDOT) will accept title to the lands and maintain the project constructed thereon in accordance with the North Carolina General Assembly, the Regulations for the Administration of the Federal-Aid Highway Program, and the policies and procedures prescribed by the Federal Highway Administration of the U.S. Department of Transportation in accordance and in compliance with all requirements imposed by Title 49, Code of Federal Regulations, U.S. Department of Transportation, Subtitle A, Office of the Secretary, Part 21, Nondiscrimination in Federally-assisted programs of the U.S. Department of Transportation pertaining to and effectuating the provisions of Title VI of the Civil Rights Act of 1964 (78 Stat. 252; 42 U.S.C. § 2000d to 2000d-4), does hereby remise, release, quitclaim and convey unto the NCDOT all the right, title and interest of the U.S. Department of Transportation in and to said lands described in Exhibit A attached hereto and made a part hereof.

(HABENDUM CLAUSE)

TO HAVE AND TO HOLD said lands and interests therein unto the North Carolina Department of Transportation (NCDOT) and its successors forever, subject, however, to the covenants, conditions, restrictions and reservations herein contained as follows, which will remain in effect for the period during which the real property or structures are used for a purpose for which Federal financial assistance is extended or for another purpose involving the provision of similar services or benefits and will be binding on the NCDOT, its successors and assigns.

The NCDOT, in consideration of the conveyance of said lands and interests in lands, does hereby covenant and agree as a covenant running with the land for itself, its successors and assigns, that (1) no person will on the grounds of race, color, or national origin, be excluded from participation in, be denied the benefits of, or be otherwise subjected to discrimination with regard to any facility located wholly or in part on, over, or under such lands hereby conveyed [,] [and]* (2) that the NCDOT will use the lands and interests in lands and interests in lands so conveyed, in compliance with all requirements imposed by or pursuant to Title 49, Code of Federal Regulations, U.S. Department of Transportation, Subtitle A, Office of the Secretary, Part 21, Non-discrimination in Federally-assisted programs of the U.S. Department of Transportation, Effectuation of Title VI of the Civil Rights Act of 1964, and as said Regulations and Acts may be amended [, and (3) that in the event of breach of any of the above-mentioned nondiscrimination conditions, the Department will have a right to enter or re-enter said lands and facilities on said land, and that above described land and facilities will thereon revert to and vest in and become the absolute property of the U.S. Department of Transportation and its assigns as such interest existed prior to this instruction].*

(*Reverter clause and related language to be used only when it is determined that such a clause is necessary in order to make clear the purpose of Title VI.)

(b) Clauses for Transfer of Real Property Acquired or Improved Under the Activity, Facility, or Program (1050.2A, Appendix C)

The following clauses will be included in deeds, licenses, leases, permits, or similar instruments entered into by the North Carolina Department of Transportation (NCDOT) pursuant to the provisions of Assurance 7(a):

1. The (grantee, lessee, permittee, etc. as appropriate) for himself/herself, his/her heirs, personal representatives, successors in interest, and assigns, as a part of the consideration hereof, does hereby covenant and agree [in the case of deeds and leases add "as a covenant running with the land"] that:
 - (i.) In the event facilities are constructed, maintained, or otherwise operated on the property described in this (deed, license, lease, permit, etc.) for a purpose for which a U.S. Department of Transportation activity, facility, or program is extended or for another purpose involving the provision of similar services or benefits, the (grantee, licensee, lessee, permittee, etc.) will maintain and operate such facilities and services in compliance with all requirements imposed by the Acts and Regulations (as may be amended) such that no person on the grounds of race, color, or national origin, will be excluded from participation in, denied the benefits of, or be otherwise subjected to discrimination in the use of said facilities.
2. With respect to licenses, leases, permits, etc., in the event of breach of any of the above Nondiscrimination covenants, the NCDOT will have the right to terminate the (lease, license, permit, etc.) and to enter, re-enter, and repossess said lands and facilities thereon, and hold the same as if the (lease, license, permit, etc.) had never been made or issued. *
3. With respect to a deed, in the event of breach of any of the above Nondiscrimination covenants, the NCDOT will have the right to enter or re-enter the lands and facilities thereon, and the above described lands and facilities will there upon revert to and vest in and become the absolute property of the NCDOT and its assigns. *

(*Reverter clause and related language to be used only when it is determined that such a clause is necessary to make clear the purpose of Title VI.)

(c) Clauses for Construction/Use/Access to Real Property Acquired Under the Activity, Facility or Program (1050.2A, Appendix D)

The following clauses will be included in deeds, licenses, permits, or similar instruments/ agreements entered into by the North Carolina Department of Transportation (NCDOT) pursuant to the provisions of Assurance 7(b):

1. The (grantee, licensee, permittee, etc., as appropriate) for himself/herself, his/her heirs, personal representatives, successors in interest, and assigns, as a part of the consideration hereof, does hereby covenant and agree (in the case of deeds and leases add, "as a covenant running with the land") that (1) no person on the ground of race, color, or national origin, will be excluded from participation in, denied the benefits of, or be otherwise subjected to discrimination in the use of said facilities, (2) that in the construction of any improvements on, over, or under such land, and the furnishing of services thereon, no person on the ground of race, color, or national origin, will be excluded from participation in, denied the benefits of, or otherwise be subjected to discrimination, (3) that the (grantee, licensee, lessee, permittee, etc.) will use the premises in compliance with all other requirements imposed by or pursuant to the Acts and Regulations, as amended, set forth in this Assurance.
2. With respect to (licenses, leases, permits, etc.), in the event of breach of any of the above Non-discrimination covenants, the NCDOT will have the right to terminate the (license, permit, etc., as appropriate) and to enter or re-enter and repossess said land and the facilities thereon, and hold the same as if said (license, permit, etc., as appropriate) had never been made or issued. *
3. With respect to deeds, in the event of breach of any of the above Nondiscrimination covenants, the NCDOT will there upon revert to and vest in and become the absolute property of the NCDOT and its assigns. *

(*Reverter clause and related language to be used only when it is determined that such a clause is necessary to make clear the purpose of Title VI.)

STANDARD SPECIAL PROVISION**ON-THE-JOB TRAINING**

(10-16-07) (Rev. 4-21-15)

Z-10

Description

The North Carolina Department of Transportation will administer a custom version of the Federal On-the-Job Training (OJT) Program, commonly referred to as the Alternate OJT Program. All contractors (existing and newcomers) will be automatically placed in the Alternate Program. Standard OJT requirements typically associated with individual projects will no longer be applied at the project level. Instead, these requirements will be applicable on an annual basis for each contractor administered by the OJT Program Manager.

On the Job Training shall meet the requirements of 23 CFR 230.107 (b), 23 USC – Section 140, this provision and the On-the-Job Training Program Manual.

The Alternate OJT Program will allow a contractor to train employees on Federal, State and privately funded projects located in North Carolina. However, priority shall be given to training employees on NCDOT Federal-Aid funded projects.

Minorities and Women

Developing, training and upgrading of minorities and women toward journeyman level status is a primary objective of this special training provision. Accordingly, the Contractor shall make every effort to enroll minority and women as trainees to the extent that such persons are available within a reasonable area of recruitment. This training commitment is not intended, and shall not be used, to discriminate against any applicant for training, whether a member of a minority group or not.

Assigning Training Goals

The Department, through the OJT Program Manager, will assign training goals for a calendar year based on the contractors' past three years' activity and the contractors' anticipated upcoming year's activity with the Department. At the beginning of each year, all contractors eligible will be contacted by the Department to determine the number of trainees that will be assigned for the upcoming calendar year. At that time the Contractor shall enter into an agreement with the Department to provide a self-imposed on-the-job training program for the calendar year. This agreement will include a specific number of annual training goals agreed to by both parties. The number of training assignments may range from 1 to 15 per contractor per calendar year. The Contractor shall sign an agreement to fulfill their annual goal for the year.\

Training Classifications

The Contractor shall provide on-the-job training aimed at developing full journeyman level workers in the construction craft/operator positions. Preference shall be given to providing training in the following skilled work classifications:

Equipment Operators	Office Engineers
Truck Drivers	Estimators
Carpenters	Iron / Reinforcing Steel Workers
Concrete Finishers	Mechanics
Pipe Layers	Welders

The Department has established common training classifications and their respective training requirements that may be used by the contractors. However, the classifications established are not all-inclusive. Where the training is oriented toward construction applications, training will be allowed in lower-level management positions such as office engineers and estimators. Contractors shall submit new classifications for specific job functions that their employees are performing. The Department will review and recommend for acceptance to FHWA the new classifications proposed by contractors, if applicable. New classifications shall meet the following requirements:

Proposed training classifications are reasonable and realistic based on the job skill classification needs, and

The number of training hours specified in the training classification is consistent with common practices and provides enough time for the trainee to obtain journeyman level status.

The Contractor may allow trainees to be trained by a subcontractor provided that the Contractor retains primary responsibility for meeting the training and this provision is made applicable to the subcontract. However, only the Contractor will receive credit towards the annual goal for the trainee.

Where feasible, 25 percent of apprentices or trainees in each occupation shall be in their first year of apprenticeship or training. The number of trainees shall be distributed among the work classifications on the basis of the contractor's needs and the availability of journeymen in the various classifications within a reasonable area of recruitment.

No employee shall be employed as a trainee in any classification in which they have successfully completed a training course leading to journeyman level status or in which they have been employed as a journeyman.

Records and Reports

The Contractor shall maintain enrollment, monthly and completion reports documenting company compliance under these contract documents. These documents and any other information as requested shall be submitted to the OJT Program Manager.

Upon completion and graduation of the program, the Contractor shall provide each trainee with a certification Certificate showing the type and length of training satisfactorily completed.

Trainee Interviews

All trainees enrolled in the program will receive an initial and Trainee/Post graduate interview conducted by the OJT program staff.

Trainee Wages

Contractors shall compensate trainees on a graduating pay scale based upon a percentage of the prevailing minimum journeyman wages (Davis-Bacon Act). Minimum pay shall be as follows:

60 percent	of the journeyman wage for the first half of the training period
75 percent	of the journeyman wage for the third quarter of the training period
90 percent	of the journeyman wage for the last quarter of the training period

In no instance shall a trainee be paid less than the local minimum wage. The Contractor shall adhere to the minimum hourly wage rate that will satisfy both the NC Department of Labor (NCDOL) and the Department.

Achieving or Failing to Meet Training Goals

The Contractor will be credited for each trainee employed by him on the contract work who is currently enrolled or becomes enrolled in an approved program and who receives training for at least 50 percent of the specific program requirement. Trainees will be allowed to be transferred between projects if required by the Contractor's scheduled workload to meet training goals.

If a contractor fails to attain their training assignments for the calendar year, they may be taken off the NCDOT's Bidders List.

Measurement and Payment

No compensation will be made for providing required training in accordance with these contract documents.

PROJECT SPECIAL PROVISIONS

GEOTECHNICAL

STANDARD SHORING (10/19/2021)

GT-1.1 - GT-1.4

TEMPORARY SOIL NAIL WALLS (10/19/2021)

GT-2.1 - GT-2.9

MECHANICALLY STABILIZED EARTH RETAINING WALLS - (10/19/2021)

GT-3.1 - GT-3.12

ARCHITECTURAL SURFACE TREATMENT (SPECIAL)

GT-4.1 - GT-4.6

DocuSigned by:
Geotechnical Engineering Unit
05/18/2023
E06538624A11498...

STANDARD SHORING:**(10-19-21)****Description**

Standard shoring includes standard temporary shoring and standard temporary mechanically stabilized earth (MSE) walls. At the Contractor's option, use standard shoring as noted in the plans or as directed. When using standard shoring, a temporary shoring design submittal is not required. Construct standard shoring based on actual elevations and shoring dimensions in accordance with the contract and Geotechnical Standard Detail No. 1801.01 or 1801.02.

Define "standard temporary shoring" as cantilever shoring that meets the standard temporary shoring detail (Geotechnical Standard Detail No. 1801.01). Define "standard temporary wall" as a temporary MSE wall with geotextile or geogrid reinforcement that meets the standard temporary wall detail (Geotechnical Standard Detail No. 1801.02). Define "standard temporary geotextile wall" as a standard temporary wall with geotextile reinforcement and "standard temporary geogrid wall" as a standard temporary wall with geogrid reinforcement.

Provide positive protection for standard shoring at locations shown in the plans and as directed. See *Temporary Shoring* provision for positive protection types and definitions.

Materials

Refer to the *Standard Specifications*.

Item	Section
Concrete Barrier Materials	1170-2
Flowable Fill, Excavatable	1000-6
Geosynthetics	1056
Grout, Type 1	1003
Portland Cement Concrete, Class A	1000
Select Materials	1016
Steel Beam Guardrail Materials	862-2
Steel Sheet Piles and H-Piles	1084
Untreated Timber	1082-2
Welded Wire Reinforcement	1070-3

Provide Type 6 material certifications for shoring materials. Use Class IV select material for temporary guardrail. Use Class A concrete that meets Article 450-2 of the *Standard Specifications* or Type 1 grout for drilled-in piles.

Based on actual shoring height, positive protection, groundwater elevation, slope or surcharge case and traffic impact at each standard temporary shoring location, use sheet piles with the minimum required section modulus or H-piles with the sizes shown in Geotechnical Standard Detail No. 1801.01. Use untreated timber with a thickness of at least 3" and a bending stress of at least 1,000 psi for timber lagging.

(A) Shoring Backfill

Use Class II, Type 1, Class III, Class V or Class VI select material or material that meets AASHTO M 145 for soil classification A-2-4 with a maximum PI of 6 for shoring backfill except do not use the following:

- (1) A-2-4 soil for backfill around culverts,

- (2) A-2-4 soil in the reinforced zone of standard temporary walls with a back slope and
- (3) Class VI select material in the reinforced zone of standard temporary geotextile walls.

(B) Standard Temporary Walls

Use welded wire reinforcement for welded wire facing, struts and wires with the dimensions and minimum wire sizes shown in Geotechnical Standard Detail No. 1801.02. Provide Type 2 geotextile for separation and retention geotextiles. Do not use more than 4 different reinforcement strengths for each standard temporary wall.

(1) Geotextile Reinforcement

Provide Type 5 geotextile for geotextile reinforcement with a mass per unit area of at least 8 oz/sy in accordance with ASTM D5261. Based on actual wall height, groundwater elevation, slope or surcharge case and shoring backfill to be used in the reinforced zone at each standard temporary geotextile wall location, provide geotextiles with ultimate tensile strengths as shown in Geotechnical Standard Detail No. 1801.02.

(2) Geogrid Reinforcement

Use geogrids for geogrid reinforcement with a roll width of at least 4 ft and an “approved” status code in accordance with the NCDOT Geosynthetic Reinforcement Evaluation Program. The list of approved geogrids is available from:

connect.ncdot.gov/resources/Geological/Pages/Products.aspx

Based on actual wall height, groundwater or flood elevation, slope or surcharge case and shoring backfill to be used in the reinforced zone at each standard temporary geogrid wall location, provide geogrids for geogrid reinforcement with short-term design strengths as shown in Geotechnical Standard Detail No. 1801.02. Geogrids are approved for short-term design strengths (3-year design life) in the machine direction (MD) and cross-machine direction (CD) based on material type. Define material type from the website above for shoring backfill as follows:

Material Type	Shoring Backfill
Borrow	A-2-4 Soil
Fine Aggregate	Class II, Type 1 or Class III Select Material
Coarse Aggregate	Class V or VI Select Material

Preconstruction Requirements

(A) Concrete Barrier

Define “clear distance” behind concrete barrier as the horizontal distance between the barrier and edge of pavement. The minimum required clear distance for concrete barrier is shown in the plans. At the Contractor’s option or if the minimum required clear distance is not available, set concrete barrier next to and up against traffic side of standard shoring except for barrier above standard temporary walls. Concrete barrier with the minimum required clear distance is required above standard temporary walls.

(B) Temporary Guardrail

Define “clear distance” behind temporary guardrail as the horizontal distance between guardrail posts and standard shoring. At the Contractor’s option or if clear distance for standard temporary shoring is less than 4 ft, attach guardrail to traffic side of shoring as shown in the plans. Place ABC in clear distance and around guardrail posts instead of pavement. Do not use temporary guardrail above standard temporary walls.

(C) Standard Shoring Selection Forms

Before beginning standard shoring construction, survey existing ground elevations in the vicinity of standard shoring locations to determine actual shoring or wall heights (H). Submit a standard shoring selection form for each location at least 7 days before starting standard shoring construction. Standard shoring selection forms are available from:

connect.ncdot.gov/resources/Geological/Pages/Geotech_Forms_Details.aspx

Construction Methods

Construct standard shoring in accordance with the *Temporary Shoring* provision.

(A) Standard Temporary Shoring Installation

Based on actual shoring height, positive protection, groundwater elevation, slope or surcharge case and traffic impact at each standard temporary shoring location, install piles with the minimum required embedment and extension for each shoring section in accordance with Geotechnical Standard Detail No. 1801.01. For concrete barrier above and next to standard temporary shoring and temporary guardrail above and attached to standard temporary shoring, use “surcharge case with traffic impact” in accordance with Geotechnical Standard Detail No. 1801.01. Otherwise, use “slope or surcharge case with no traffic impact” in accordance with Geotechnical Standard Detail No. 1801.01. If refusal is reached before driven piles attain the minimum required embedment, use drilled-in H-piles with timber lagging for standard temporary shoring.

(B) Standard Temporary Walls Installation

Based on actual wall height, groundwater elevation, slope or surcharge case, geotextile or geogrid reinforcement and shoring backfill in the reinforced zone at each standard temporary wall location, construct walls with the minimum required reinforcement length and number of reinforcement layers for each wall section in accordance with Geotechnical Standard Detail No. 1801.02. For standard temporary walls with pile foundations in the reinforced zone, drive piles through reinforcement after constructing temporary walls.

For standard temporary walls with interior angles less than 90°, wrap geosynthetics at acute corners as directed by the Engineer. Place geosynthetics as shown in Geotechnical Standard Detail No. 1801.02. Place separation geotextiles between shoring backfill and backfill, natural ground or culverts along the sides of the reinforced zone perpendicular to the wall face. For Class V or VI select material in the reinforced zone, place separation geotextiles between shoring backfill and backfill or natural ground on top of and at the back of the reinforced zone.

Measurement and Payment

Standard shoring will be measured and paid in accordance with the *Temporary Shoring* provision.

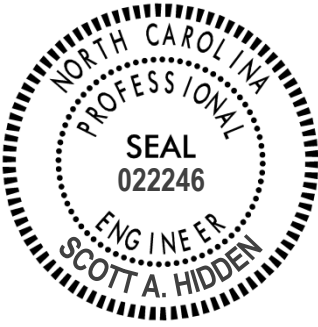

DocuSigned by:
Scott A. Hidden
F760CAEB96FC4D3...
03/27/2023

TEMPORARY SOIL NAIL WALLS:**(10-19-21)****Description**

Construct temporary soil nail walls consisting of soil nails spaced at a regular pattern and connected to a reinforced shotcrete face. A soil nail consists of a solid or hollow steel bar grouted in a drilled hole inclined at an angle below horizontal. At the Contractor's option, use temporary soil nail walls instead of temporary shoring for full cut sections. Design and construct temporary soil nail walls based on actual elevations and wall dimensions in accordance with the contract and accepted submittals. Use a prequalified Anchored Wall Contractor to construct temporary soil nail walls. Define "soil nail wall" as a temporary soil nail wall and "Soil Nail Wall Contractor" as the Anchored Wall Contractor installing soil nails and applying shotcrete. Define "nail" as a soil nail.

Provide positive protection for soil nail walls at locations shown in the plans and as directed. See *Temporary Shoring* provision for positive protection types and definitions.

Materials

Refer to Division 10 of the *Standard Specifications*.

Item	Section
Geocomposites	1056
Portland Cement	1024-1
Reinforcing Steel	1070
Shotcrete	1002
Select Material, Class IV	1016
Steel Plates	1072-2
Water	1024-4

Use neat cement grout that only contains cement and water with a water cement ratio of 0.4 to 0.5 which is approximately 5.5 gallons of water per 94 lb of Portland cement. Provide grout with a compressive strength at 3 and 28 days of at least 1,500 psi and 4,000 psi, respectively.

Use Class IV select material for temporary guardrail. Provide soil nails consisting of grouted steel bars and nail head assemblies. Use deformed solid steel bars that meet AASHTO M 275 or M 31, Grade 60, 75 or 80. Splice solid bars in accordance with Article 1070-9 of the *Standard Specifications*. Use hollow steel bars manufactured by DYWIDAG-Systems International USA Inc., Nucor Skyline, Williams Form Engineering Corp. or an approved equal.

Use centralizers that meet Article 34.3.4 of the *AASHTO LRFD Bridge Construction Specifications*. Provide nail head assemblies consisting of nuts, washers and bearing plates. Use steel plates for bearing plates and steel washers and hex nuts recommended by the Soil Nail Manufacturer.

Provide Type 6 material certifications for soil nail materials in accordance with Article 106-3 of the *Standard Specifications*. Store steel materials on blocking at least 12" above the ground and protect it at all times from damage; and when placing in the work make sure it is free from dirt, dust, loose mill scale, loose rust, paint, oil or other foreign materials. Load, transport, unload and store soil nail wall materials so materials are kept clean and free of damage. Bent, damaged or defective materials will be rejected.

Preconstruction Requirements

(A) Concrete Barrier

Define “clear distance” behind concrete barrier as the horizontal distance between the barrier and edge of pavement. The minimum required clear distance for concrete barrier is shown in the plans. At the Contractor’s option or if the minimum required clear distance is not available, set concrete barrier next to and up against traffic side of soil nail walls except for barrier above walls. Concrete barrier with the minimum required clear distance is required above soil nail walls.

(B) Temporary Guardrail

Define “clear distance” behind temporary guardrail as the horizontal distance between guardrail posts and soil nail walls. At the Contractor’s option or if clear distance for soil nail walls is less than 4 ft, use temporary guardrail with 8 ft posts and a clear distance of at least 2.5 ft. Place ABC in clear distance and around guardrail posts instead of pavement.

(C) Soil Nail Wall Designs

Before beginning soil nail wall design, survey existing ground elevations in the vicinity of wall locations to determine actual design heights (H). Use a prequalified Anchored Wall Design Consultant to design soil nail walls. Provide designs sealed by a Design Engineer approved as a Geotechnical Engineer (key person) for the Anchored Wall Design Consultant.

Design soil nail walls in accordance with the plans and the *AASHTO LRFD Bridge Design Specifications* unless otherwise required. Design soil nails that meet the following unless otherwise approved:

- (1) Horizontal and vertical spacing of at least 3 ft,
- (2) Inclination of at least 12° below horizontal and
- (3) Diameter of 4" to 10".

Do not extend nails beyond right-of-way or easement limits. If existing or future obstructions such as foundations, pavements, pipes, inlets or utilities will interfere with nails, maintain a clearance of at least 6" between obstructions and nails.

Design soil nail walls for a traffic surcharge of 250 psf if traffic will be above and within H of walls. This traffic surcharge does not apply to construction traffic. Design soil nail walls for any construction surcharge if construction traffic will be above and within H of walls. For temporary guardrail with 8 ft posts above soil nail walls, analyze shotcrete and top row of nails for a nominal horizontal load of 300 lb/ft of wall with a load factor of 1.0.

Place geocomposite sheet drains with a horizontal spacing of no more than 10 ft and center drains between adjacent nails. Attach sheet drains to excavation faces. Design shotcrete in accordance with Article 11.12.6.2 of the *AASHTO LRFD Bridge Design Specifications*.

Submit PDF files of working drawings and design calculations for soil nail wall designs in accordance with Article 105-2 of the *Standard Specifications*. Submit working drawings showing plan views, wall profiles, typical sections and details of soil nail wall

design and construction sequence. Include details in working drawings of soil nail locations, unit grout/ground bond strengths, shotcrete reinforcement and if necessary, obstructions extending through walls or interfering with nails. Include details in construction sequence of excavation, grouting, installing reinforcement, nail testing and shotcreting with mix designs and shotcrete nozzleman certifications. Do not begin soil nail wall construction until a design submittal is accepted.

Submit design calculations for each wall section with different surcharge loads, geometry or material parameters. Include analysis of temporary conditions during construction in design calculations. At least one analysis is required for each wall section with different nail lengths. Analyze internal and compound stability with a computer software program that uses limit equilibrium methods and submit all PDF output files from the program with the design calculations. See Article C11.12.2 of the AASHTO LRFD specifications for determining the maximum soil nail force, $T_{\max sn}$. Once $T_{\max sn}$ and pullout length behind slip surface, L_P , are determined from limit equilibrium methods at the target soil failure resistance factor (1 over factor of safety output from computer software), use these values for soil nail (pullout and tensile resistance) and wall facing (flexure, punching shear and headed-stud tensile resistance) design in accordance with Articles 11.12.5.2, 11.12.6.1 and 11.12.6.2 of the AASHTO LRFD specifications.

- (1) When designing soil nail walls with computer software Snail manufactured by the California Department of Transportation (CALTRANS), use Snail version 2.2.0 or later, to calculate factors of safety and $T_{\max sn}$ and L_P values in accordance with the following: Allowable Stress Design for Analysis Method with no load factors applied except those applied to factored surcharge loads from structures or traffic,
- (2) Perform Below Toe Search option selected when any soil layer has a friction angle less than 30° and
- (3) Default value of 0.33 for Interface Friction Reduction Factor.

When designing soil nail walls with computer software other than Snail, use bi-linear (or tri-linear, as applicable) search surfaces intended to reproduce Snail results. Factors of safety and $T_{\max sn}$ and L_P values are acceptable if they are within 5% of the factors of safety and $T_{\max sn}$ and L_P values calculated by the Engineer using the computer software Slide2 manufactured by Rocscience, Inc.

(D) Preconstruction Meeting

Before starting soil nail wall construction, hold a preconstruction meeting to discuss the construction, inspection and testing of the soil nail walls. If this meeting occurs before all soil nail wall submittals have been accepted, additional preconstruction meetings may be required before beginning construction of soil nail walls without accepted submittals. The Resident, District or Bridge Maintenance Engineer, Area Construction Engineer, Geotechnical Operations Engineer, Contractor and Soil Nail Wall Contractor Superintendent will attend preconstruction meetings.

Construction Methods

Control drainage during construction in the vicinity of soil nail walls. Direct run off away from soil nail walls and areas above and behind walls.

Install foundations located behind soil nail walls before beginning wall construction. Do not excavate behind soil nail walls. If overexcavation occurs, repair walls with an approved method and a revised soil nail wall design may be required.

Install positive protection in accordance with the contract and accepted submittals. Use PCB in accordance with Section 1170 of the *Standard Specifications* and Roadway Standard Drawing No. 1170.01. Use temporary guardrail in accordance with Section 862 of the *Standard Specifications* and Roadway Standard Drawing No. 862.01, 862.02 and 862.03.

(A) Excavation

Excavate for soil nail walls from the top down in accordance with the accepted submittals. Excavate in staged horizontal lifts with no negative batter (excavation face leaning forward). Excavate lifts in accordance with the following:

- (1) Heights not to exceed vertical nail spacing,
- (2) Bottom of lifts no more than 3 ft below nail locations for current lift and
- (3) Horizontal and vertical alignment within 6" of location shown in the accepted submittals.

Remove any cobbles, boulders, rubble or debris that will protrude more than 2" into the required shotcrete thickness. Rocky ground such as colluvium, boulder fills and weathered rock may be difficult to excavate without leaving voids.

Apply shotcrete to excavation faces within 24 hours of excavating each lift unless otherwise approved. Shotcreting may be delayed if it can be demonstrated that delays will not adversely affect excavation stability. If excavation faces will be exposed for more than 24 hours, use polyethylene sheets anchored at top and bottom of lifts to protect excavation faces from changes in moisture content.

If an excavation becomes unstable at any time, suspend soil nail wall construction and temporarily stabilize the excavation by immediately placing an earth berm up against the unstable excavation face. When this occurs, repair walls with an approved method and a revised soil nail wall design may be required.

Do not excavate the next lift until nail installations and testing and shotcrete application for the current lift are accepted and grout and shotcrete for the current lift have cured at least 3 days and 1 day, respectively.

(B) Soil Nails

Drill and grout nails the same day and do not leave drill holes open overnight. Control drilling and grouting to prevent excessive ground movements, damaging structures and pavements or fracturing rock and soil formations. If ground heave or subsidence occurs, suspend soil nail wall construction and take corrective action to minimize movement. If property damage occurs, make repairs with an approved method and a revised soil nail wall design may be required.

The drilling, steel bar and grouting requirements below are for solid bar nails and may not apply to hollow bar nails. Hollow bar nails are typically installed by simultaneously drilling and grouting as a sacrificial drill bit is advanced and grout is pumped through the bar. For hollow bar nails, submit drilling and grouting procedures for approval before

installing soil nails.

(1) Drilling

Use drill rigs of the sizes necessary to install soil nails and with sufficient capacity to drill through whatever materials are encountered. Drill straight and clean holes with the dimensions and inclination shown in the accepted submittals. Drill holes within 6" of locations and 2° of inclination shown in the accepted submittals unless otherwise approved.

Stabilize drill holes with temporary casings if unstable, caving or sloughing material is anticipated or encountered. Do not use drilling fluids to stabilize drill holes or remove cuttings.

(2) Steel Bars

Center solid steel bars in drill holes with centralizers. Securely attach centralizers along bars at no more than 8 ft centers. Attach uppermost and lowermost centralizers 18" from excavation faces and ends of holes.

Do not insert solid steel bars into drill holes until hole locations, dimensions, inclination and cleanliness are approved. Do not vibrate, drive or otherwise force bars into holes. If a steel bar cannot be completely and easily inserted into a drill hole, remove the bar and clean or redrill the hole.

(3) Grouting

Mix and place grout in accordance with Subarticles 1003-5, 1003-6 and 1003-7 of the *Standard Specifications*. Remove oil, rust inhibitors, residual drilling fluids and similar foreign materials from holding tanks/hoppers, stirring devices, pumps, lines, tremie pipes and any other equipment in contact with grout before use. Measure grout temperature, density and flow during grouting with at least the same frequency grout cubes are made for compressive strength. Perform density and flow field tests in the presence of the Engineer in accordance with American National Standards Institute/American Petroleum Institute Recommended Practice 13B-1 (Section 4, Mud Balance) and ASTM C939 (Flow Cone), respectively.

Inject grout at the lowest point of drill holes through tremies, e.g., grout tubes, casings, hollow-stem augers or drill rods, in one continuous operation. Fill drill holes progressively from ends of holes to excavation faces and withdraw tremies at a slow even rate as holes are filled to prevent voids in grout. Extend tremies into grout at least 5 ft at all times except when grout is initially placed in holes.

Provide grout free of segregation, intrusions, contamination, structural damage or inadequate consolidation (honeycombing). Cold joints in grout are not allowed except for test nails. Remove any temporary casings as grout is placed and record grout volume for each drill hole.

(4) Nail Heads

Install nail head assemblies after shotcreting. Before shotcrete reaches initial set, seat bearing plates and tighten nuts so plates contact shotcrete uniformly. If uniform contact is not possible, install nail head assemblies on mortar pads so nail

heads are evenly loaded.

(C) Sheet Drains

Install geocomposite sheet drains as shown in the accepted submittals. Before installing shotcrete reinforcement, place sheet drains with the geotextile side against excavation faces. For highly irregular faces and at the discretion of the Engineer, sheet drains may be placed after shotcreting over weep holes through the shotcrete. Hold sheet drains in place with anchor pins so drains are in continuous contact with surfaces to which they are attached and allow for full flow the entire height of soil nail walls. Discontinuous sheet drains are not allowed. If splices are needed, overlap sheet drains at least 12" so flow is not impeded. Cut off excess sheet drain length and expose drain ends below shotcrete when soil nail wall construction is complete.

(D) Shotcrete

Clean ungrouted zones of drill holes and excavation faces of loose materials, mud, rebound and other foreign material. Moisten surfaces to receive shotcrete. Install shotcrete reinforcement in accordance with the contract and accepted submittals. Secure reinforcing steel so shooting does not displace or vibrate reinforcement. Install approved thickness gauges on 5 ft centers in the horizontal and vertical directions to measure shotcrete thickness.

Apply shotcrete in accordance with the contract, accepted submittals and Subarticle 1002-3(F) of the *Standard Specifications*. Use approved shotcrete nozzlemen who made satisfactory preconstruction test panels to apply shotcrete. Direct shotcrete at right angles to excavation faces except when shooting around reinforcing steel. Rotate nozzle steadily in small circular patterns and apply shotcrete from bottom of lifts up.

Make shotcrete surfaces uniform and free of sloughing or sagging. Completely fill ungrouted zones of drill holes and any other voids with shotcrete. Taper construction joints to a thin edge over a horizontal distance of at least the shotcrete thickness. Wet joint surfaces before shooting adjacent sections.

Repair surface defects as soon as possible after shooting. Remove any shotcrete which lacks uniformity, exhibits segregation, honeycombing or lamination or contains any voids or sand pockets and replace with fresh shotcrete to the satisfaction of the Engineer. Protect shotcrete from freezing and rain until shotcrete reaches initial set.

(E) Construction Records

Provide 2 copies of soil nail wall construction records within 24 hours of completing each lift. Include the following in construction records:

- (1) Names of Soil Nail Wall Contractor, Superintendent, Nozzleman, Drill Rig Operator, Project Manager and Design Engineer;
- (2) Wall description, county, Department's contract, TIP and WBS element number;
- (3) Wall station and number and lift location, dimensions, elevations and description;
- (4) Nail locations, dimensions and inclinations, bar types, sizes and grades and temporary casing information;

- (5) Date and time drilling begins and ends, steel bars are inserted into drill holes, grout and shotcrete are mixed and arrives on-site and grout placement and shotcrete application begins and ends;
- (6) Grout volume, temperature, flow and density records;
- (7) Ground and surface water conditions and elevations if applicable;
- (8) Weather conditions including air temperature at time of grout placement and shotcrete application; and
- (9) All other pertinent details related to soil nail wall construction.

After completing each soil nail wall or stage of a wall, provide a PDF file of all corresponding construction records.

Nail Testing

“Proof tests” are performed on nails incorporated into walls, i.e., production nails. Define “test nail” as a nail tested with a proof test. Proof tests are typically required for at least one nail per nail row per soil nail wall or at least 5% of production nails, whichever is greater. More or less test nails may be required depending on subsurface conditions encountered. The Engineer will determine the number and locations of proof tests required. Do not test nails until grout and shotcrete attain the required 3-day compressive strength.

(A) Test Equipment

Use the following equipment to test nails:

- (1) Two dial gauges with rigid supports,
- (2) Hydraulic jack and pressure gauge and
- (3) Jacking block or reaction frame.

Provide dial gauges with enough range and precision to measure the maximum test nail movement to 0.001". Use pressure gauges graduated in 100 psi increments or less. Submit identification numbers and calibration records for load cells, jacks and pressure gauges with the soil nail wall design. Calibrate each jack and pressure gauge as a unit.

Align test equipment to uniformly and evenly load test nails. Use a jacking block or reaction frame that does not damage or contact shotcrete within 3 ft of nail heads. Place dial gauges opposite each other on either side of test nails and align gauges within 5° of bar inclinations. Set up test equipment so resetting or repositioning equipment during nail testing is not needed.

(B) Test Nails

Test nails include both unbonded and bond lengths. Grout only bond lengths before nail testing. Provide unbonded and bond lengths of at least 3 ft and 10 ft, respectively.

Steel bars for production nails may be overstressed under higher test nail loads. If necessary, use larger size or higher grade bars with more capacity for test nails instead of shortening bond lengths to less than the minimum required.

(C) Proof Tests

Test proof test nails in accordance with the accepted submittals and Article 34.5.5.3, respectively of the *AASHTO LRFD Bridge Construction Specifications*.

(D) Test Nail Acceptance

Submit 2 copies of test nail records including load versus movement and time versus creep movement plots within 24 hours of completing each proof test. The Engineer will review the test nail records to determine if test nails are acceptable. Test nail acceptance is based in part on the acceptance criteria in Article 34.5.5.4 of the *AASHTO LRFD Bridge Construction Specifications*.

Maintain stability of unbonded lengths for subsequent grouting. If a test nail is accepted but the unbonded length cannot be satisfactorily grouted, do not incorporate the test nail into the soil nail wall and add another production nail to replace the test nail.

If the Engineer determines a test nail is unacceptable, either perform additional proof tests on adjacent production nails or revise the soil nail design or installation methods for the production nails represented by the unacceptable test nail as determined by the Engineer. Submit a revised soil nail wall design for acceptance, provide an acceptable test nail with the revised design or installation methods and install additional production nails for the nails represented by the unacceptable test nail.

After completing nail testing for each soil nail wall or stage of a wall, provide a PDF file of all corresponding test nail records.

Measurement and Payment

Temporary soil nail walls will be measured and paid in square feet. Temporary soil nail walls will be paid for at the contract unit price for *Temporary Shoring*. Temporary soil nail walls will be measured as the square feet of exposed wall face area. No measurement will be made for any embedment or pavement thickness above soil nail walls.

The contract unit price for *Temporary Shoring* will be full compensation for providing soil nail wall designs, submittals, labor, tools, equipment and soil nail wall materials, excavating, hauling and removing excavated materials, installing and testing soil nails, grouting, shotcreting and supplying sheet drains and any incidentals necessary to construct soil nail walls. No additional payment will be made and no extension of completion date or time will be allowed for repairing property damage, overexcavations or unstable excavations, unacceptable test nails or thicker shotcrete.

No payment will be made for temporary shoring not shown in the plans or required by the Engineer including shoring for OSHA reasons or the Contractor's convenience. No value engineering proposals will be accepted based solely on revising or eliminating shoring locations shown in the plans or estimated quantities shown in the bid item sheets as a result of actual field measurements or site conditions.

PCB will be measured and paid in accordance with Section 1170 of the *Standard Specifications*. No additional payment will be made for anchoring PCB for soil nail walls. Costs for anchoring PCB will be incidental to soil nail walls.

Temporary guardrail will be measured and paid for in accordance with Section 862 of the *Standard Specifications*.



DocuSigned by:
Scott A. Hidden
F760CAEB96FC4D3...
03/27/2023

MECHANICALLY STABILIZED EARTH RETAINING WALLS**(10-19-21)****1.0 GENERAL**

Construct mechanically stabilized earth (MSE) retaining walls consisting of steel or geosynthetic reinforcement in the reinforced zone connected to vertical facing elements. Use precast concrete panels for vertical facing elements and coarse aggregate in the reinforced zone unless noted otherwise in the plans. Provide reinforced concrete coping and pile sleeves as required. Design and construct MSE retaining walls based on actual elevations and wall dimensions in accordance with the contract and accepted submittals. Use a prequalified MSE Wall Installer to construct MSE retaining walls.

Define MSE wall terms as follows:

Geosynthetic Reinforcement – Polyester Type (PET), HDPE or Polypropylene (PP) geosynthetic grids, i.e., geogrid reinforcement or polymer straps, i.e., geostrip reinforcement,

Geogrid – PET, HDPE or PP geogrid,

Reinforcement – Steel or geosynthetic reinforcement,

Aggregate – Coarse or fine aggregate,

Panel – Precast concrete panel,

Coping – Precast or CIP concrete coping,

Design Height (H) – Wall height + wall embedment as shown in the plans,

MSE Wall – Mechanically stabilized earth retaining wall,

MSE Wall Vendor – Vendor supplying the chosen MSE wall system,

MSE Panel Wall – MSE wall with panels,

MSE Segmental Wall – MSE wall with segmental retaining wall (SRW) units and

Abutment Wall – MSE wall with bridge foundations in any portion of the reinforced zone or an MSE wall connected to an abutment wall (even if bridge foundations only penetrate a small part of the reinforced zone, the entire MSE wall is considered an abutment wall).

For bridge approach fills behind end bents with MSE abutment walls, design reinforcement connected to end bent caps in accordance with the plans and this provision. Construct Type III Reinforced Bridge Approach Fills in accordance with the *Bridge Approach Fills* provision and Roadway Detail Drawing No. 422D10.

Use an approved MSE wall system in accordance with the plans and any NCDOT restrictions or exceptions for the chosen system. Value engineering proposals for other MSE wall systems will not be considered. Do not use MSE wall systems with an “approved for provisional use” status for MSE walls with design heights greater than 35 ft or walls supporting or adjacent to railroads or interstate highways. The list of approved MSE wall systems with approval status is available from:

connect.ncdot.gov/resources/Geological/Pages/Products.aspx

2.0 MATERIALS

Refer to the *Standard Specifications*.

Item

Section

Aggregate	1014
Asphalt Concrete Base Course, Type B25.0C	620
Corrugated Steel Pipe	1032-3
Epoxy, Type 3A	1081
Geosynthetics	1056
Grout, Type 3	1003
Joint Materials	1028
Portland Cement Concrete, Class A	1000
Precast Retaining Wall Coping	1077
Reinforcing Steel	1070
Retaining Wall Panels	1077
Segmental Retaining Wall Units	1040-4
Select Material, Class V	1016
Shoulder Drain Materials	816-2
Steel Pipe	1036-4(A)

Use galvanized corrugated steel pipe with a zinc coating weight of 2 oz/sf (G200) for pile sleeves. Provide Type 2 geotextile for filtration and separation geotextiles. Use Class A concrete for CIP coping, leveling concrete and pads. Use galvanized steel pipe, threaded rods and nuts for the PET geogrid reinforcement vertical obstruction detail. Provide galvanized Grade 36 anchor rods and Grade A hex nuts that meet AASHTO M 314 for threaded rods and nuts.

Use panels and SRW units from producers approved by the Department and licensed by the MSE Wall Vendor. Provide steel strip connectors embedded in panels fabricated from structural steel that meets the requirements for steel strip reinforcement. Unless required otherwise in the contract, produce panels with a smooth flat final finish that meets Article 1077-11 of the *Standard Specifications*. Accurately locate and secure reinforcement connectors in panels and maintain required concrete cover. Produce panels within 1/4" of the panel dimensions shown in the accepted submittals.

Damaged panels or SRW units with excessive discoloration, chips or cracks as determined by the Engineer will be rejected. Do not damage reinforcement connection devices or mechanisms in handling or storing panels and SRW units.

Store steel materials on blocking at least 12" above the ground and protect it at all times from damage; and when placing in the work make sure it is free from dirt, dust, loose mill scale, loose rust, paint, oil or other foreign materials. Handle and store geosynthetics in accordance with Article 1056-2 of the *Standard Specifications*. Load, transport, unload and store MSE wall materials so materials are kept clean and free of damage. Bent, damaged or defective materials will be rejected.

A. Aggregate

Use standard size No. 57, 57M, 67 or 78M that meets Table 1005-1 of the *Standard Specifications* for coarse aggregate and the following for fine aggregate:

1. Standard size No. 1S, 2S, 2MS or 4S that meets Table 1005-2 of the *Standard*

Specifications or

2. Gradation that meets Class III, Type 3 select material in accordance with Article 1016-3 of the *Standard Specifications*.

Fine aggregate is exempt from mortar strength in Subarticle 1014-1(E) of the *Standard Specifications*. Use fine aggregate with a maximum organic content of 1.0%. Provide aggregate with chemical properties that meet the following requirements:

AGGREGATE pH REQUIREMENTS		
Aggregate Type (in reinforced zone)	Reinforcement or Connector Material	pH
Coarse or Fine	Steel	5 – 10
Coarse or Fine	Geosynthetic	4.5 – 9

AGGREGATE ELECTROCHEMICAL REQUIREMENTS (Steel Reinforcement/Connector Materials Only)			
Aggregate Type (in reinforced zone)	Resistivity	Chlorides	Sulfates
Coarse	$\geq 5,000 \Omega \cdot \text{cm}$	$\leq 100 \text{ ppm}$	$\leq 200 \text{ ppm}$
Fine	$\geq 3,000 \Omega \cdot \text{cm}$		

Use aggregate from sources participating in the Department's Aggregate QC/QA Program as described in Section 1006 of the *Standard Specifications*. Sample and test aggregate in accordance with the *Mechanically Stabilized Earth Wall Aggregate Sampling and Testing Procedures*.

B. Reinforcement

Provide steel or geosynthetic reinforcement supplied by the MSE Wall Vendor or a manufacturer approved or licensed by the vendor. Use reinforcement approved for the chosen MSE wall system. The list of approved reinforcement for each MSE wall system is available from the website shown elsewhere in this provision.

1. Steel Reinforcement

Provide Type 1 material certifications in accordance with Article 106-3 of the *Standard Specifications* for steel reinforcement. Use welded wire grid reinforcement ("mesh", "mats" and "ladders") that meet Article 1070-3 of the *Standard Specifications* and steel strip reinforcement ("straps") that meet ASTM A572, A1011 or A463. Use 10 gauge or heavier structural steel Grade 50 or higher for steel strip reinforcement. Galvanize steel reinforcement in accordance with Section 1076 of the *Standard Specifications* or provide aluminized steel strip reinforcement that meet ASTM A463, Type 2-100.

2. Geosynthetic Reinforcement

Provide Type 1 material certifications and identify geosynthetic reinforcement in accordance with Article 1056-3 of the *Standard Specifications*. Define machine direction (MD) and cross-machine direction (CD) for geogrids per Article 1056-3 of the *Standard Specifications*.

Use HDPE or PP geogrid for geogrid reinforcement cast into backwalls of end bent caps. Use PET or HDPE geogrid for geogrid reinforcement connected directly to SRW units and only HDPE geogrid for geogrid reinforcement cast into panels.

Provide extruded geogrids produced in the United States and manufactured from punched and drawn polypropylene sheets for PP geogrids that meet the following:

PP GEOGRID REQUIREMENTS		
Property	Requirement¹	Test Method
Aperture Dimensions ²	1" x 1.2"	N/A
Minimum Rib Thickness ²	0.07" x 0.07"	N/A
Tensile Strength @ 2% Strain ²	580 lb/ft x 690 lb/ft	ASTM D6637, Method B
Tensile Strength @ 5% Strain ²	1,200 lb/ft x 1,370 lb/ft	
Ultimate Tensile Strength ²	1,850 lb/ft x 2,050 lb/ft	
Junction Efficiency ³ (MD)	93%	ASTM D7737
Flexural Rigidity ⁴	2,000,000 mg-cm	ASTM D7748
Aperture Stability Modulus ⁵	0.55 lb-ft/degrees	ASTM D7864
UV Stability (Retained Strength)	100% (after 500 hr of exposure)	ASTM D4355

- MARV per Article 1056-3 of the *Standard Specifications* except dimensions and thickness are nominal.
- Requirement for MD x CD.
- Junction Efficiency (%) = (Average Junction Strength ($X_{j_{ave}}$) / Ultimate Tensile Strength in the MD from ASTM D6637, Method A) \times 100.
- Test specimens two ribs wide, with transverse ribs cut flush with exterior edges of longitudinal ribs, and sufficiently long to enable measurement of the overhang dimension.
- Applied moment of 17.7 lb-inch (torque increment).

C. Bearing Pads

For MSE panel walls, use preformed ethylene propylene diene monomer rubber bearing pads that meet ASTM D2000 Grade 2, Type A, Class A with a durometer hardness of 60 or 80 \pm 5. Provide bearing pads with thicknesses that meet the following:

BEARING PAD THICKNESS	
Facing Area per Panel (A)	Minimum Pad Thickness After Compression (based on 2 times panel weight above pads)
$A \leq 30$ sf	1/2"
$30 \text{ sf} < A \leq 75$ sf	3/4"

D. Miscellaneous Components

Miscellaneous components may include connectors (e.g., anchors, bars, clamps, pins, plates, ties, etc.), fasteners (e.g., bolts, nuts, washers, etc.) and any other MSE wall components not included above. Use 10 gauge or heavier structural steel Grade 50 or higher for steel strip panel anchors and connectors. Galvanize steel components in accordance with Section 1076 of the *Standard Specifications*. Provide miscellaneous components approved for the chosen MSE wall system. The list of approved miscellaneous components for each MSE wall system is available from the website shown elsewhere in this provision.

3.0 PRECONSTRUCTION REQUIREMENTS**A. MSE Wall Surveys**

The Retaining Wall Plans show a plan view, typical sections, details, notes and an elevation or profile view (wall envelope) for each MSE wall. Before beginning MSE wall design, survey existing ground elevations shown in the plans and other elevations in the vicinity of MSE wall locations as needed. For proposed slopes above or below MSE walls, survey existing ground elevations to at least 10 ft beyond slope stake points. Based on these elevations, finished grades and actual MSE wall dimensions and details, submit revised wall envelopes for acceptance. Use accepted wall envelopes for design.

B. MSE Wall Designs

For MSE wall designs, submit PDF files of working drawings and design calculations at least 30 days before the preconstruction meeting. Note name and NCDOT ID number of the panel or SRW unit production facility on working drawings. Do not begin MSE wall construction until a design submittal is accepted.

Use a prequalified MSE Segmental Wall Design Consultant to design MSE segmental walls. Provide MSE segmental wall designs sealed by a Design Engineer approved as a Geotechnical Engineer (key person) for the MSE Segmental Wall Design Consultant. Provide MSE panel wall designs sealed by a Design Engineer licensed in the state of North Carolina and employed or contracted by the MSE Wall Vendor.

Design MSE walls in accordance with the plans, *AASHTO LRFD Bridge Design Specifications* and any NCDOT restrictions for the chosen MSE wall system unless otherwise required. For abutment walls only, design MSE walls for seismic if wall sites meet either or both of the following:

- Wall site is in seismic zone 2 based on Figure 2-1 of the *Structure Design Manual*,
- Wall site is classified as AASHTO Site Class E, as noted in the plans, and is in or west of Pender, Duplin, Wayne, Johnston, Wake, Durham or Person County.

Connect reinforcement to panels or SRW units with methods or devices approved for the chosen system. Use a uniform reinforcement length throughout the height of the

wall of at least 0.7H or 6 ft, whichever is longer, unless noted otherwise in the plans. Extend the reinforced zone at least 6" beyond end of reinforcement. Do not locate drains, the reinforced zone or leveling pads outside right-of-way or easement limits.

Use the simplified method for determining maximum reinforcement loads and design parameters approved for the chosen MSE wall system or default values in accordance with the AASHTO LRFD specifications. Design steel components including reinforcement and connectors for the design life noted in the plans and aggregate type in the reinforced zone. If an MSE wall system with geosynthetic reinforcement includes any steel parts for obstructions, bin walls, connections or other components, design steel exposed to aggregate for the design life noted in the plans and aggregate type in the reinforced zone. Use "loss of galvanizing" metal loss rates for nonaggressive backfill in accordance with the AASHTO LRFD specifications for galvanized and aluminized steel and metal loss rates for carbon steel in accordance with the following:

CARBON STEEL CORROSION RATES	
Aggregate Type (in reinforced zone)	Carbon Steel Loss Rate (after coating depletion)
Coarse	0.47 mil/year
Fine (except abutment walls)	0.58 mil/year
Fine (abutment walls)	0.70 mil/year

For PET or HDPE geogrid and geostrip reinforcement and geosynthetic connectors, use approved geosynthetic properties for the design life noted in the plans and aggregate type in the reinforced zone. For geogrid reinforcement connected to end bent caps, embed reinforcement or connectors in caps as shown in the plans. For PP geogrid reinforcement connected to end bent caps, use the following design parameters for the aggregate type in the reinforced approach fill.

PP GEOGRID REINFORCEMENT DESIGN PARAMETERS				
Aggregate Type (in reinforced zone)	T_{al} (MD)	F*	α	ρ
Coarse	400 lb/ft	0.70	0.8	32.0°
Fine	428 lb/ft	0.54	0.8	28.35°

Where,

- T_{al} = long-term design strength (LTDS),
 F* = pullout resistance factor,
 α = scale effect correction factor and
 ρ = soil-geogrid friction angle.

When noted in the plans, design MSE walls for a live load (traffic) surcharge of 250 psf in accordance with Figure C11.5.6-3(b) of the AASHTO LRFD specifications. For steel beam guardrail with 8 ft posts or concrete barrier rail above MSE walls, analyze top 2 reinforcement layers for traffic impact loads in accordance with Section 7.2 of *FHWA Design and Construction of Mechanically Stabilized Earth Walls and*

Reinforced Soil Slopes – Volume I (Publication No. FHWA-NHI-10-024) except use the following for geosynthetic reinforcement rupture:

$$\phi T_{al} R_c \geq T_{max} + (T_I / RF_{CR})$$

Where,

- ϕ = resistance factor for tensile resistance in accordance with Section 7.2.1 of the FHWA MSE wall manual,
- T_{al} = long-term geosynthetic design strength approved for chosen MSE wall system,
- R_c = reinforcement coverage ratio = 1 for continuous geosynthetic reinforcement,
- T_{max} = factored static load in accordance with Section 7.2 of the FHWA MSE wall manual,
- T_I = factored impact load in accordance with Section 7.2 of the FHWA MSE wall manual and
- RF_{CR} = creep reduction factor approved for chosen MSE wall system.

When shown in the plans for abutment walls, use pile sleeves to segregate piles from aggregate in the reinforced zone. If existing or future obstructions such as foundations, guardrail, fence or handrail posts, moment slabs, pavements, pipes, inlets or utilities will interfere with reinforcement, maintain a clearance of at least 3" between obstructions and reinforcement unless otherwise approved. Design reinforcement for obstructions and locate reinforcement layers so all of reinforcement length is within 3" of corresponding connection elevations. Modify PET geogrid reinforcement for obstructions as shown in the plans.

Use 6" thick CIP unreinforced concrete leveling pads beneath panels and SRW units that are continuous at steps and extend at least 6" in front of and behind bottom row of panels or SRW units. Unless required otherwise in the plans, embed top of leveling pads in accordance with the following requirements:

WALL EMBEDMENT REQUIREMENTS		
Front Slope¹ (H:V)	Minimum Embedment Depth² (whichever is greater)	
6:1 or flatter (except abutment walls)	H/20	1 ft for H ≤ 10 ft 2 ft for H > 10 ft
6:1 or flatter (abutment walls)	H/10	2 ft
> 6:1 to < 3:1	H/10	2 ft
3:1 to 2:1	H/7	2 ft

1. Front slope is as shown in the plans.
2. H is the maximum design height per wall.

When noted in the plans, locate a continuous aggregate shoulder drain along the base of the reinforced zone behind the aggregate. Provide wall drainage systems consisting of drains and outlet components in accordance with Roadway Standard Drawing No. 816.02.

For MSE panel walls, cover joints at back of panels with filtration geotextiles at least 12" wide. If the approval of the chosen MSE wall system does not require a minimum number of bearing pads, provide the number of pads in accordance with the following:

NUMBER OF BEARING PADS		
Facing Area per Panel (A)	Maximum Height of Wall Above Horizontal Panel Joint	Minimum Number of Pads per Horizontal Panel Joint
A ≤ 30 sf	25 ft	2
	35 ft ¹	3
30 sf < A ≤ 75 sf	25 ft	3
	35 ft ¹	4

1. Additional bearing pads per horizontal panel joint may be required for wall heights above joints greater than 35 ft.

For MSE segmental walls, coarse aggregate is required in any SRW unit core spaces and between and behind SRW units for a horizontal distance of at least 18".

Separation geotextiles are required between the aggregate and overlying fill sections. When noted in the plans, separation geotextiles are also required at the back of the reinforced zone between the aggregate and backfill or natural ground. When placing pavement sections directly on the reinforced zone, cap aggregate with 4" of asphalt concrete base course. Unless required otherwise in the plans, use reinforced concrete coping at top of walls that meets the following requirements:

1. Coping dimensions as shown in the plans,
2. At the Contractor's option, coping that is precast or CIP concrete for MSE panel walls unless CIP coping is required as shown in the plans,
3. CIP concrete coping for MSE segmental walls and
4. At the Contractor's option and when shown in the plans, CIP concrete coping that extends down back of panels or SRW units or connects to panels or SRW units with dowels.

For MSE segmental walls with dowels, attach dowels to top courses of SRW units in accordance with the following:

1. Set dowels in core spaces of SRW units filled with grout instead of coarse aggregate or
2. Embed adhesively anchored dowels in holes of solid SRW units with epoxy.

For MSE panel walls with coping, connect CIP concrete coping or leveling concrete for precast concrete coping to top row of panels with dowels cast into panels. When concrete barrier rail is required above MSE walls, use concrete barrier rail with moment slab as shown in the plans.

Submit working drawings and design calculations for acceptance in accordance with

Article 105-2 of the *Standard Specifications*. Submit working drawings showing plan views, wall profiles with foundation pressures, typical sections with reinforcement and connection details, aggregate locations and types, geotextile locations and details of leveling pads, panels or SRW units, coping, bin walls, slip joints, pile sleeves, etc. If necessary, include details on working drawings for concrete barrier rail with moment slab, reinforcement splices if allowed for the chosen MSE wall system, reinforcement connected to end bent caps, curved MSE walls with tight (short) radii and obstructions extending through walls or interfering with reinforcement, leveling pads, barriers or moment slabs. Submit design calculations for each wall section with different surcharge loads, geometry or material parameters. At least one analysis is required for each wall section with different reinforcement lengths. When designing MSE walls with computer software other than MSEW, use MSEW manufactured by ADAMA Engineering, Inc. to verify the design. At least one MSEW analysis is required per 100 ft of wall length with at least one analysis for the wall section with the longest reinforcement. Submit electronic MSEW input files and PDF output files with design calculations.

C. Preconstruction Meeting

Before starting MSE wall construction, hold a preconstruction meeting to discuss the construction and inspection of the MSE walls. If this meeting occurs before all MSE wall submittals have been accepted, additional preconstruction meetings may be required before beginning construction of MSE walls without accepted submittals. The Resident or Bridge Maintenance Engineer, Area Construction Engineer, Geotechnical Operations Engineer, Contractor and MSE Wall Installer Superintendent will attend preconstruction meetings.

4.0 CORROSION MONITORING

Corrosion monitoring is required for MSE walls with steel reinforcement. The Engineer will determine the number of monitoring locations and where to install the instrumentation. Contact M&T before beginning wall construction. M&T will provide the corrosion monitoring instrumentation kits and if necessary, assistance with installation.

5.0 SITE ASSISTANCE

Unless otherwise approved, an MSE Wall Vendor representative is required to assist and guide the MSE Wall Installer on-site for at least 8 hours when the first panels or SRW units and reinforcement layer are placed. If problems are encountered during construction, the Engineer may require the vendor representative to return to the site for a time period determined by the Engineer.

6.0 CONSTRUCTION METHODS

Control drainage during construction in the vicinity of MSE walls. Direct run off away from MSE walls, aggregate and backfill. Contain and maintain aggregate and backfill and protect material from erosion.

Excavate as necessary for MSE walls in accordance with the accepted submittals. If applicable and at the Contractor's option, use temporary shoring for wall construction instead of temporary slopes to construct MSE walls. Define "temporary shoring for wall construction" as temporary shoring not shown in the plans or required by the Engineer including shoring for OSHA reasons or the Contractor's convenience.

Unless required otherwise in the plans, install foundations and if required, pile sleeves located in the reinforced zone before placing aggregate or reinforcement. Brace piles in the reinforced zone to maintain alignment when placing and compacting aggregate. Secure piles together with steel members near top of piles. Clamp members to piles instead of welding if bracing is at or below pile cut-off elevations.

Notify the Engineer when foundation excavation is complete. Do not place leveling pad concrete, aggregate or reinforcement until excavation dimensions and foundation material are approved.

Construct CIP concrete leveling pads at elevations and with dimensions shown in the accepted submittals and in accordance with Section 420 of the *Standard Specifications*. Cure leveling pads at least 24 hours before placing panels or SRW units.

Erect and support panels and stack SRW units so the final wall position is as shown in the accepted submittals. Stagger SRW units to create a running bond by centering SRW units over joints in the row below as shown in the accepted submittals. Space bearing pads in horizontal panel joints as shown in the accepted submittals and cover all panel joints with filtration geotextiles as shown in the accepted submittals. Attach filtration geotextiles to back of panels with adhesives, tapes or other approved methods.

Construct MSE walls with the following tolerances:

- A. SRW units are level from front to back and between units when checked with a 4 ft long level,
- B. Vertical joint widths are 1/4" maximum for SRW units and 3/4", $\pm 1/4$ " for panels,
- C. Final wall face is within 3/4" of horizontal and vertical alignment shown in the accepted submittals when measured along a 10 ft straightedge and
- D. Final wall plumbness (batter) is not negative (wall face leaning forward) and within 0.5° of vertical unless otherwise approved.

Place reinforcement at locations and elevations shown in the accepted submittals and within 3" of corresponding connection elevations. Install reinforcement with the direction shown in the accepted submittals. Before placing aggregate, pull geosynthetic reinforcement taut so it is in tension and free of kinks, folds, wrinkles or creases. Reinforcement may be spliced once per reinforcement length if shown in the accepted submittals. Use reinforcement pieces at least 6 ft long. Contact the Engineer when unanticipated existing or future obstructions such as foundations, guardrail, fence or handrail posts, pavements, pipes, inlets or utilities will interfere with reinforcement. To avoid obstructions, deflect, skew or modify reinforcement as shown in the accepted submittals.

Place aggregate in the reinforced zone in 8" to 10" thick lifts. Compact fine aggregate in accordance with Subarticle 235-3(C) of the *Standard Specifications*. Use only hand operated compaction equipment to compact aggregate within 3 ft of panels or SRW units. At a distance greater than 3 ft, compact aggregate with at least 4 passes of an 8 ton to 10 ton vibratory roller in a direction parallel to the wall face. Smooth wheeled or rubber tired rollers are also acceptable for compacting aggregate. Do not use sheepsfoot, grid rollers or other types of compaction equipment with feet. Do not displace or damage reinforcement when placing and compacting aggregate. End dumping directly on geosynthetics is not permitted. Do not operate heavy equipment on reinforcement until it is covered with at least 8" of aggregate. Replace any damaged reinforcement to the satisfaction of the Engineer.

Backfill for MSE walls outside the reinforced zone in accordance with Article 410-8 of the *Standard Specifications*. If a drain is required, install wall drainage systems as shown in the accepted submittals and in accordance with Section 816 of the *Standard Specifications*. If pile sleeves are required, fill sleeves with loose uncompacted sand before constructing end bent caps.

Install dowels as necessary for SRW units and place and construct coping and leveling concrete as shown in the accepted submittals. Construct leveling concrete in accordance with Section 420 of the *Standard Specifications*. Construct CIP concrete coping in accordance with Subarticle 452-4(B) of the *Standard Specifications*. When single faced precast concrete barrier is required in front of and against MSE walls, stop coping just above barrier so coping does not interfere with placing barrier up against wall faces. If the gap between a single faced barrier and wall face is wider than 2", fill gap with Class V select material (standard size No. 78M stone). Otherwise, fill gap with backer rod and seal joint between barrier and MSE wall with silicone sealant.

When separation geotextiles are required, overlap adjacent geotextiles at least 18" and hold geotextiles in place with wire staples or anchor pins as needed. Seal joints above and behind MSE walls between coping and concrete slope protection with silicone sealant.

7.0 MEASUREMENT AND PAYMENT

MSE Retaining Wall No. ___ will be measured and paid in square feet. MSE walls will be measured as the square feet of wall face area with the pay height equal to the difference between top of wall and top of leveling pad elevations. Define "top of wall" as top of coping or top of panels or SRW units for MSE walls without coping.

The contract unit price for *MSE Retaining Wall No. ___* will be full compensation for providing designs, submittals, labor, tools, equipment and MSE wall materials, excavating, hauling and removing excavated materials, placing and compacting aggregate and backfill material and supplying site assistance, leveling pads, panels, SRW units, reinforcement, aggregate, wall drainage systems, geotextiles, aggregate concrete base course, bearing pads, coping, miscellaneous components and any incidentals necessary to construct MSE walls. The contract unit price for *MSE Retaining Wall No. ___* will also be full compensation for reinforcement and connector design for reinforcement connected to end

bent caps, wall modifications for obstructions, pile sleeves filled with sand, joints sealed with silicone sealant and gaps between barriers and MSE walls filled with backer rod or No. 78M stone, if required.

No separate payment will be made for temporary shoring for wall construction. Temporary shoring for wall construction will be incidental to the contract unit price for *MSE Retaining Wall No. __*.

The contract unit price for *MSE Retaining Wall No. __* does not include the cost for ditches, fences, handrails, barrier or guardrail associated with MSE walls as these items will be paid for elsewhere in the contract. The contract unit price for *MSE Retaining Wall No. __* also does not include the cost for constructing bridge approach fills behind end bents with MSE abutment walls. See *Bridge Approach Fills* provision for measurement and payment of Type III Reinforced Bridge Approach Fills.

Where it is necessary to provide backfill material behind the reinforced zone from sources other than excavated areas or borrow sources used in connection with other work in the contract, payment for furnishing and hauling such backfill material will be paid as extra work in accordance with Article 104-7 of the *Standard Specifications*. Placing and compacting such backfill material is not considered extra work but is incidental to the work being performed.

Payment will be made under:

Pay Item
MSE Retaining Wall No. __

Pay Unit
Square Foot



DocuSigned by:
Scott A. Hidden
F760CAEB86FC4D3...
05/01/2023

ARCHITECTURAL SURFACE TREATMENT**(SPECIAL)****1.0 GENERAL**

The work covered by this special provision consists of constructing textured surfaces on formed reinforced concrete surfaces as indicated on the Plans and in this Special Provision. The Contractor shall furnish all materials, labor, equipment, and incidentals necessary for the construction of architectural concrete surface treatment using simulated stone masonry form liners (molds) and a compatible concrete coloring system.

The architectural concrete surface treatment should match the appearance (stone size and shape, stone color, and stone texture, pattern, and relief) of natural stone and rock, in the project vicinity, or as directed by the Engineer. Grout pattern joints (mortar joints) and bed thickness should re-create the appearance and color of natural stone on the cast-in-place and/or precast concrete panels for the Soil Nail Retaining Wall No. -Y- as indicated in the Plans, this Special Provision, or as directed by the Engineer.

2.0 SUBMITTALS

Shop Drawings - The Contractor shall submit for review and acceptance, plan and elevation views and details showing overall simulated stone pattern, joint locations, form tie locations, and end, edge or other special conditions. The drawings should include typical cross sections of applicable surfaces, joints, corners, stone relief, stone size, pitch/working line, mortar joint and bed depths. If necessary, the Contractor shall revise the shop drawings until the proposed form liner patterns and arrangement have been accepted by the Engineer. Shop drawings should be of sufficient scale to show the detail of all stone and joints patterns. The size of the sheets used for the shop drawings shall be 22" x 34".

The form liner shall be patterned such that long continuous horizontal or vertical lines do not occur on the finished exposed surface. The line pattern shall be random in nature and shall conceal construction joint lines. Special attention should be given to details for wrapping form liners around corners.

Shop drawings shall be reviewed and accepted prior to fabrication of form liners.

Sample Panels – After the shop drawings have been reviewed and accepted by the Engineer, the Contractor shall construct 24" x 24" transportable sample panel(s) at the project site. The materials used in construction of the sample panel(s) shall comply with section 420 of the Standard Specifications. The sample panel(s) shall be constructed using approved form liners. Sample panels will be required for each different form liner pattern that is to be used on the project. Any sample panel that is not accepted by the Engineer is to be removed from the project site and a new sample panel produced at no additional expense to the Department.

Architectural surface treatments and patterns of the finished work shall achieve the same final effect as demonstrated on the accepted sample panel(s). Upon acceptance by the Engineer, the sample panel(s) shall be used as the quality standard for the project. After

the acceptance of the completed structure, the Contractor shall dispose of the sample panels as directed by the Engineer.

3.0 MATERIAL REQUIREMENTS

Form Liner – The form liner shall be a high quality, re-useable product manufactured of high strength urethane rubber or other approved material which attaches easily to the form work system, and shall not compress more than ¼” when concrete is poured at a rate of 10 vertical feet (3 vertical meters) per hour. The form liners shall be removable without causing deterioration of the surface or underlying concrete.

The Contractor is required to use the same source of form liner for all required elements. The architectural concrete surface treatment should match the appearance (stone size and shape, stone texture, pattern and relief) of cut and mortared natural stone to resemble a pattern similar to the #919 Weathered Cut Ashlar by Architectural Polymer, Inc., as shown below.



All texture is to be in addition to the nominal thickness of each element within tolerances. Maximum relief of the textured surface shall be ¼ inch or less.

The form liners are to be patterned as referenced above and as directed by the Engineer.

The Contractor may choose one of the following manufactures to supply the stone-textured surface treatment as specified above. One form liner pattern will be used on this project.

- Architectural Polymers <http://www.apformliner.com/>
- Custom Rock <http://www.customrock.com/>
- Fitzgerald <http://www.formliners.com/>
- Scott System <http://www.scottsystem.com/>
- Spec Formliners <http://www.specformliners.com/>
- U.S. Formliner <http://www.usformliner.com/>
- American Formliners <http://www.americanformliners.com/>

Form Release Agent – Form release agent shall be a nonstaining petroleum distillate free from water, asphaltic, and other insoluble residue, or an equivalent product. Form release agents shall be compatible with the color system applied and any special surface finish.

Form Ties - Form ties shall be set back a minimum of 2” from the finished concrete surface. The ties shall be designed so that all material in the device to a depth of at least 2” back of the concrete face (bottom of simulated mortar groove) can be disengaged and removed without spalling or damaging the concrete. The Contractor shall submit the type of form ties to the Engineer for approval.

Concrete Color – The final coloration of the wall is to of a base stain and two additional stain colors and shall be placed in such a way as to appear as natural stone. Stain the sample panel using the proposed colors and once approved by the Engineer they can be used on the wall.

Color stains shall be a special penetrating stain mix as provided by the manufacturer and shall be in multiple colors of gray, brown, white, and black to achieve a full, natural color variation in the finished surface. The stain shall create a surface finish that is breathable (allowing water vapor transmission), and that resists deterioration from water, acid, alkali, fungi, sunlight, or weathering. Stain mix shall meet the requirements for mildew resistance of Federal Test Method Standard 144, Method 6271, and requirements for weathering resistance of 1.000 hours accelerated exposure measures by Weatherometer in accordance with ASTM G 26. Color samples must be submitted for approval. Concrete stains shall be supplied by one of the following or as approved by the Engineer.

Sherwin Williams
H & C Shield Plus
101 Prospect Ave., NW
Cleveland, OH 44115

Canyon Tone Stain
United Coatings
E 1901 Cataldo
Green Acres, Washington 90016

Cementrate Acrylic Stain
Fosroc, Inc.
55 Skyline Drive
Plainview, New York 11803

Hydroshield Stain
Robson-Downes Associates, Inc.
Oxford, Maryland 21654

Anti-Graffiti Coating Application – The coating shall be applied after full cure of the color coating. Apply the anti-graffiti coating by brush, roller or airless spray when ambient temperature is between 45 and 90 degrees F, and the surface temperature is between 50 and 100 degrees F. Ensure the surface is clean and dry before applying the anti-graffiti coating. The minimum dry film thickness of the anti-graffiti coating shall be 2.0 mils.

Quality Standards - Manufacturer of simulated stone masonry form liners and custom coloring system shall have at least five years experience making stone masonry molds and color stains to create formed concrete surfaces to match natural stone shapes, surface textures and colors. The Contractor shall schedule

A pre-installation conference with manufacturer representative and the Engineer to assure understanding of simulated stone masonry form liner use, color application, requirements for construction of sample panel(s), and to coordinate the work. The Contractor shall be required to disclose their source of simulated stone masonry manufacturer and final coloration contractor at the Preconstruction Conference.

4.0 CONSTRUCTION

Simulated Stone Form Liner System and Surface Finish

The Contractor shall demonstrate his workmanship by first constructing a sample panel of the simulated stone masonry form liner pattern and coloration. The sample panel shall be constructed on site a minimum of six weeks prior to the construction of the walls. The sample panel shall measure 3' height by 5' length by 8" thick and shall be unreinforced, vertically cast, and of concrete construction to determine the surface texture resulting from the use of form liners. Sample panels shall be cast, finished, and stained until approved by the Engineer. The approved sample panel shall remain on site as the basis for comparison for work constructed on the project. The architectural surface treatment and pattern of the finished work shall achieve the same final effect as demonstrated on the approved sample panel. Upon completion of all work, the panel shall be removed from the site.

The simulated stone form liners are to be capable of withstanding anticipated concrete pour pressures without leakage or without causing physical or visual defects. The simulated stone form liners are to be removable without causing concrete surface

deterioration or weakness in the substrate. Form release agents, form stripping methods, patching materials, as well as related construction are to be in accordance with the manufacturer's recommendations or as directed by the Engineer.

Linear butt joints shall be carefully blended into the approved pattern and finished off the final concrete surface. No visible vertical or horizontal seams or conspicuous form marks created by butt joining will be permitted.

The Contractor shall submit the type of form ties to be used in this construction to the Engineer for approval prior to use. Form tie holes shall be finished in accordance with standard concreting practices and shall be acceptable to the Engineer. All patching material shall exactly match the color and appearance of the poured concrete surface.

Concrete surfaces shall be clean, free of laitance, dirt, dust, grease, efflorescence, paint, or other foreign material, following manufacturer's specifications for surface preparation prior to application of color stain. The surface area shall also be free of blemishes, discolorations, surface voids, and unnatural form marks. The Contractor is advised that sandblasting will not be allowed for cleaning concrete surfaces. Pressure washing for removal of laitance shall be used.

If required on the plans, the Contractor shall provide a Color Application Artist who is trained in the special techniques to achieve realistic surface appearances, if requested by the Engineer. To avoid contaminating or damaging the wall surfaces, color stain application shall be scheduled when all concrete work is completed, the concrete has cured a minimum of 28 days, the surface has been determined to be acceptable for coloring, and after adjacent earthwork is complete. The Contractor is to coordinate coloring applications without interference from other work. The Contractor is required to apply coloring to an appropriate test area of 50 square feet and as designated by the Engineer, which will serve as a quality standard for the remaining surface to be colored. Upon approval of the test area by the Engineer, the remaining surfaces may be colored. Stains shall be applied when ambient air temperatures are in accordance with manufacturer's specifications or as directed by the Engineer. The number of coats of stain applied shall be in accordance with manufacturer's specifications or as directed by the Engineer. Treated surfaces located adjacent to exposed soil or pavement shall be temporarily covered to prevent dirt or soil splatter from rain.

Following the completion of all work, repairs of any damage made by other construction operations shall be made to the form lined and colored surfaces as directed by the Engineer.

Experience and Qualifications - The Contractor shall have a minimum of three consecutive years of experience in architectural concrete surface treatment construction on similar types of projects. The Contractor shall furnish to the Engineer 5 references who were responsible for supervision of similar projects and will testify to the successful completion of these projects. Include name, address, telephone number, and specific type of application.

5.0 MEASUREMENT AND PAYMENT

Architectural Surface Treatment as described in this Special Provision will be paid for as the contract unit price for “Architectural Surface Treatment”. Payment will include the furnishing and use of all form liners, the construction, finishing, staining, anti-graffiti coating and removal of all sample panels, and all equipment, materials, labor, and incidentals necessary to complete the work in conformance with the Contract Documents.

Payment will be made under:

Architectural Surface Treatment.....Square Feet

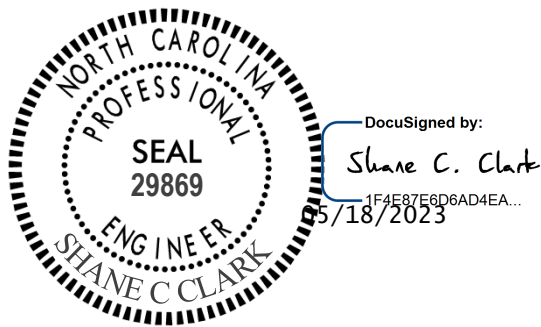

TC-1

U-2729

Forsyth County

WORK ZONE TRAFFIC CONTROL Project Special Provisions Table of Contents

Special Provision	Page
ADA Compliant Pedestrian Traffic Control Devices	TC-2
High Visibility Devices	TC-3
Pedestrian Transport Service	TC-5
Sequential Flashing Warning Lights	TC-7

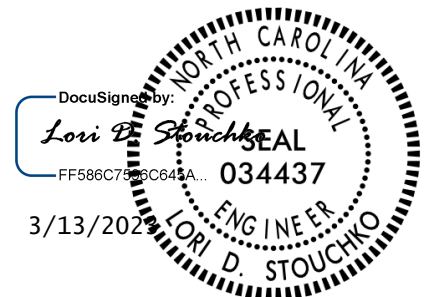

TC-2

U-2729

Forsyth County

ADA COMPLIANT PEDESTRIAN TRAFFIC CONTROL DEVICES:

(10/31/2017) (Rev. 6/3/2022)

Description

Furnish, install, and maintain all ADA compliant pedestrian traffic control devices for existing pedestrian facilities that are disrupted, closed, or relocated by planned work activities.

The ADA compliant pedestrian traffic control devices used to either close, redirect, divert or detour pedestrian traffic are Pedestrian Channelizing Devices, and Audible Warning Devices.

Construction Methods

The ADA compliant pedestrian traffic control devices involved in the closing or redirecting of pedestrians as designated on the Transportation Management Plan (TMP) shall be manufactured and assembled in accordance with the requirements of the Americans with Disabilities Act (ADA) and be on the NCDOT approved products list.

Pedestrian Channelizing Devices shall be manufactured and assembled to be connected as to eliminate any gaps that allow pedestrians to stray from the channelizing path. Any Pedestrian Channelizing Devices used to close or block a pedestrian facility shall have a "SIDEWALK CLOSED" sign affixed to it and any audible warning devices, if designated on the TMP.

Audible Warning Devices shall be manufactured to include a locator tone activated by a motion sensor and have the ability to program a message for a duration of at least 1 minute. The motion sensor shall have the ability to detect pedestrians a minimum of 10' away. The voice module may be automatic or it may be push button activated. If push button activated, it shall be mounted at a height of approximately 3.5 feet, but no more than 4 feet, above the pedestrian facility.

Measurement and Payment

Pedestrian Channelizing Devices will be measured and paid as the maximum number of linear feet of *Pedestrian Channelizing Devices* furnished, acceptably placed, and in use at any one time during the life of the project.

No direct payment will be made for any sign affixed to a pedestrian channelizing device. Signs mounted to pedestrian channelizing devices will be considered incidental to the device.

Audible Warning Devices will be measured and paid as the maximum number of *Audible Warning Devices* furnished, acceptably installed, and in use at any one time during the life of the project.

TC-3

U-2729

Forsyth County

Relocation, replacement, repair, maintenance, or disposal of *Pedestrian Channelizing Devices* and *Audible Warning Devices* will be incidental to the pay item.

Payment will be made under:

Pay Item	Pay Unit
Pedestrian Channelizing Devices	Linear Foot
Audible Warning Devices	Each

HIGH VISIBILITY DEVICES

(10/25/2019) (Rev. 5/10/2021)

Description

Furnish and install High Visibility Devices for projects on interstates and freeways. High Visibility Devices include drums, skinny drums, stationary work zone signs and rigid portable work zone signs. All of these devices shall be new. Used devices are not acceptable.

Materials

A) General

Use materials in accordance with the Manufacturer's recommendations that will retain both durability and retroreflectivity as described elsewhere in this specification for a period of at least 36 months.

The following are required High Visibility Devices to be used for work zone performance applications.

- Drums
- Stationary Work Zone Signs
- Rigid Portable Work Zone Signs

All drums and skinny drums shall be new and meet the existing requirements of Section 1089-5 of the NCDOT Standard Specifications for Roads and Structures and shall have Grade B flexible, fluorescent orange sheeting that meets the retroreflective requirements of Section 1092-2 of the NCDOT Standard Specifications for Roads and Structures.

All stationary work zone signs shall be new and meet the existing requirements of Section 1089-1 of the NCDOT Standard Specifications for Roads and Structures. Legend overlays are prohibited and shall not be accepted on the interstate/freeway or associated intersecting roadways. Vertical sign post reflector strips shall be added to all stationary sign supports. Use Grade B fluorescent

TC-4

U-2729

Forsyth County

orange for work zone signs and Grade B fluorescent yellow for exit sign supports. Install strips a minimum of 6' in length on sign supports with one sign mounted and a minimum of 4.5' in length for sign supports with two or more signs mounted vertically.

All portable work zone signs shall be new and have composite substrates as described in Section 1089-1 of the NCDOT Standard Specifications for Roads and Structures. Roll-up signs do not meet the requirements of this provision. The remainder of the existing requirements of Section 1089-1 of the NCDOT Standard Specifications for Roads and Structures remain. Used sign stands are acceptable.

B) Material Qualifications/Certifications

Only use materials as listed above that are on the NCDOT Approved Products List. In addition, provide a Type 3 Material Certification for all materials in accordance with Section 106-3 and Section 1087-4.

(C) Performance

Poor performance of any device or sign at any site, whether or not related to a specific contract may be grounds for removing the material from the NCDOT Approved Products List and/or removing from any project under contract.

Construction Methods

All requirements of Section 1110-3 and Section 1130-3 of the NCDOT Standard Specifications for Roads and Structures shall apply except roll up signs are not permitted for use.

The use of skinny drums is prohibited for any nighttime lane closures on interstates/freeways.

Maintenance

Replace any sign or drum that prematurely fails due to any damage or defect that causes it to perform unsatisfactorily with an "in kind" device of similar quality and age according to the guidelines set forth in the American Traffic Safety Service Association's (ATSSA) Quality Guidelines for Work Zone Traffic Control Devices. An "in kind" replacement sign or drum is not required to be new, however, it shall be less than 1 year old and have 100% of its original sheeting area and at least 85% of the retroreflective qualities of a new device, so that it is undetectable adjacent to the original devices and signs placed on the project.

Measurement and Payment

High Visibility Drums will be measured and paid as the maximum number of drums placed and in use at any one time during the life of the project.

TC-5

U-2729

Forsyth County

High Visibility Stationary Signs will be measured as the actual number of square feet satisfactorily installed at each location and accepted by the Engineer. Where a particular sign is used at more than one location, measurement will be made at each location.

High Visibility Portable Signs will be measured and paid as the actual number of square feet satisfactorily installed and accepted by the Engineer. Payment will be made for the initial installation only. Relocation of signs will be incidental to the measurement of the quantity of High Visibility Portable Signs.

No direct payment will be made for stationary work zone sign supports or portable work zone sign stands. All stationary work zone sign support or portable work zone sign stands will be incidental to the work of providing work zone signs.

Payment will be made under:

Pay Item:

High Visibility Drums
High Visibility Stationary Signs
High Visibility Portable Signs

Pay Unit

Each
Square Foot
Square Foot

PEDESTRIAN TRANSPORT SERVICE:

(09/07/2018)

Description

The Contractor shall provide a Pedestrian Transport Service through and/or around the project when a traversable, firm, stable, and slip-resistant path for pedestrians cannot be maintained through the work area. At minimum, the Pedestrian Transport Service shall be on-call between the hours of 7:00 a.m. and 8:00 p.m. Monday thru Sunday, and operate at no-cost to the users.

Construction Methods

The Contractor shall enlist the services of a registered, licensed, and insured transportation service (which may include ride-sharing or taxi services) during the times listed above.

The Pedestrian Transport Service shall operate on an on-call basis with wait times not exceeding 15 minutes. Pedestrians shall be able to request a ride by calling or text messaging a conspicuously posted number using standard cellular phone. The posted number shall either automatically dispatch a transport vehicle to the pedestrian's location, or shall connect to a responsible individual who can manually dispatch a transport vehicle to the pedestrian's location.

Solely requiring pedestrians to use a third-party cellular phone application (smart phone app) to dispatch the transport vehicle shall be considered non-compliant with this section, but offering a

TC-6

U-2729

Forsyth County

smart phone app to directly dispatch the service is encouraged as a supplement to the posted number.

Pedestrians shall not be required to present any form of payment for the service, and shall not be required to provide any form of identification other than their name.

The Contractor shall install notification signage and Audible Warning Devices at pedestrian path closure points to notify pedestrians of the Pedestrian Transport Service, instruct them how to dispatch the service (by either texting or calling the posted number), and where to wait. Both the Audible Warning Devices and notification signage shall convey the same message and be approved by the Engineer.

The Pedestrian Transport Service shall operate at a prudent speed and have designated, safe, accessible, and traversable areas for pedestrians to wait for the pedestrian transport vehicle. There shall be a location for the Pedestrian Transport Service to safely pull the transport vehicle off the roadway traffic lane or into a closed traffic lane to load or unload passengers. Pedestrians with ADA needs shall not be unloaded in a location where the surface or facility is not accessible or traversable.

If flaggers are present on the job, the flaggers shall direct pedestrians to use the Pedestrian Transport Service to pass through or around the work zone.

Measurement and Payment

Pedestrian Transport Service (per trip) will be measured and paid as the actual number of completed trips provided to pedestrians. Multiple pedestrians transported using a single trip will be paid as a single trip. No direct payment will be made for the responsible individual dispatching the vehicle the smart phone app, pedestrian loading and unloading areas, or notification signage as these items will be considered incidental to the Pedestrian Transport Service.

Audible Warning Devices will be measured and paid under the ADA Compliant Pedestrian Traffic Control Devices special provision.

Payment will be made under:

Pay Item	Pay Unit
Pedestrian Transport Service (per trip)	Each

SEQUENTIAL FLASHING WARNING LIGHTS

TC-7

U-2729

Forsyth County

(10/08/2016) (Rev. 5/10/2021)

Description

Furnish and install Sequential Flashing Warning Lights on drums used for the merging tapers of nightly lane closures on all multilane roadways with speed limits of 55 mph or greater.

Materials

The Sequential Flashing Warning Lights shall meet all of the requirements for warning lights within the current edition of the Manual of Uniform Traffic Control Devices (MUTCD).

Each light unit shall be capable of operating fully and continuously for a minimum of 200 hours when equipped with a standard battery set.

Each light in the sequence shall be flashed at a rate of not less than 55 times per minute and not more than 75 times per minute. The flash rate and flash duration shall be consistent throughout the sequence.

Supply a Type 3 Certification (Independent Test Lab results) documenting all actual test results for the specified parameters contained in the Institute of Transportation Engineer's (ITE's) *Purchase Specification for Flashing and Steady Burn Warning Lights*. The laboratory shall also identify all manufacturer codes and part numbers for the incandescent lamp or LED clusters, lenses, battery, and circuitry, and the total width of the light with the battery in place. The complete assembly shall be certified as crashworthy when firmly affixed to the channelizing device.

All Sequential Flashing Warning Lights shall be on the NCDOT Approved Products List.

Construction Methods

These lights shall flash sequentially beginning with the first light and continuing until the final light.

The Sequential Flashing Warning Lights shall automatically flash in sequence when placed on the drums that form the merging taper.

The number of lights used in the drum taper shall equal the number of drums used in the taper.

Drums are the only channelizing device allowed to mount sequential flashing warning lights.

The Sequential Flashing Warning Lights shall be weather independent and visual obstructions shall not interfere with the operation of the lights.

The Sequential Flashing Warning Lights shall automatically sequence when placed in line in an open area with a distance between lights of 10 to 100 feet.

TC-8

U-2729

Forsyth County

If one light fails, the flashing sequence shall continue. If more than 1 light fails, all of the lights are to be automatically turned to the “off” mode. Non-sequential flashing is prohibited.

When lane closures are not in effect, the Sequential Flashing Warning Lights shall be deactivated.

Measurement and Payment

Sequential Flashing Warning Lights will be measured and paid as the maximum number of sequential flashing warning lights satisfactorily installed and properly functioning at any one time during the life of the project.

This includes all materials and labor to install, maintain and remove all the Sequential Flashing Warning Lights.

Pay Item

Sequential Flashing Warning Lights

Pay Unit

Each

Exhibit C

PROJECT SPECIAL PROVISIONS
Utility Construction

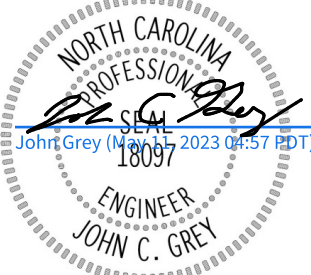
 <p>THE WOOTEN COMPANY 300 S. Main Street, Lower Level Winston-Salem, NC 27101-5217 336.722.5326 fax 336.722.5329 License No. F-0115</p>	
<p>Document Not Considered Final Unless All Signatures Completed.</p>	<p>(Seal)</p>

UTILITY OWNER

City of Winston-Salem
Todd Lewis, PE

Physical Address
100 East First Street
P.O. Box 2511
Winston-Salem, NC 27102
Phone: (336) 747-6842
Email: toddl@cityofws.org

Exhibit C

PROJECT SPECIAL PROVISIONS
Utility Construction

General Note:

In these Project Special Provisions, where manufacturers are listed for certain products, the cited examples are used only to denote the quality standard of the products desired, and they do not restrict bidders to a specific brand, make, manufacturer or specific name; they are used only to set forth and convey to bidders the general style, type, character and quality of products desired; and equivalent products will be acceptable, subject to review and approval by utility system owner.

Revise the 2018 Standard Specifications as follows:

Page 1-49, Sub-article 105-11 Inspection of Work

add the following paragraphs:

VIDEO INSPECTION: As a final measure required for acceptance, the Contractor shall clean and televise all sanitary sewer mains prior to requesting final inspection. The Contractor shall televise the entire sewer main and all service connections using standardized NASSCO (PACP, MACP, & LACP) practices, unless otherwise specified below. The process shall begin at the upstream manhole for each segment, and proceed to the downstream manhole for that same segment. Connections shall be televised from the cleanout to the main. Video inspection may occur only after Record Drawings are accepted and approved by the City of Winston-Salem. Prior to beginning the process, a 24 hour notice must be given by the Contractor to the Engineer. Prior to video inspection in paved areas, structures must be raised to final grade and 2" of asphalt must be in place. The City will not accept video that is more than 180 days old unless approved by the Engineer.

The cameras used for inspection shall be ones specifically designed and constructed for sanitary sewer pipeline inspection. Lighting for the cameras shall be suitable to provide a clear color picture of the entire periphery of the pipe. The cameras used for mains must be able to pan, tilt and zoom in order to allow for 360 degree viewing. The television system shall be equipped to indicate the camera travel distance in feet by display on the video viewing screen. All television equipment (camera, monitor, etc.) must be capable of producing picture quality which is satisfactory to the Engineer.

Within 2 hours of the video inspection, the Contractor shall clean the sewer mains and service connections with a high velocity water jet. All debris shall be collected in the downstream manhole and removed by the Contractor. Debris shall not be released into the existing sewer system. During the entire video process, the distance counter must be set at zero at each upstream manhole for each segment (set the counter at zero at the ground for each service connection). The Contractor will be required to pan and tilt at

each manhole and at each service connection. The interior of each manhole must be marked with the manhole station (or manhole number) with paint or some other legible identifier (6" - 12" high letters or numbers). Each cleanout stack must be marked with the house number or the lot number. For mains, the Contractor will also be required to pan, tilt and zoom at all couplings, at all dates for lined ductile iron pipe, and when any potential problems or abnormalities are noticed or suspected. Travel speed for the camera will be 15 - 30 feet per minute. The following video screen data will be required:

- Project name and project number
- Date of inspection
- Travel distance and time
- Station of start and end manholes
- Depth of start and end manholes
- Size of main
- Type of pipe

All above data shall be shown at the start and end manholes of each segment. While the camera is moving through the main and service connections, distance shall be the only data shown on the screen (top left or top right of screen).

For mains, a stream of water approximately 1" in width must be flowing during the entire video process. For service connections, a minimum of 5 gallons of water must be introduced into each cleanout stack just prior to the video process. In all cases, the flow must be shown on the bottom of the video screen.

Two copies of the entire video inspection along with a properly formatted PACP standard exchange database shall be submitted to the Engineer on a data disc (DVD or flash drive). A "properly formatted PACP standard exchange database" includes properly PACP coded defects (NASSCO version 6.x), proper media paths to associated video files, and all asset IDs used in the inspection must match what the submitted record drawings indicate for each asset. The video file shall be formatted to MPEG-4 (MP4) with software compatible and readable by the City of Winston-Salem. The City of Winston-Salem shall not be responsible for purchasing additional software necessary to view the video file. Each inspection (manhole to manhole or cleanout to main) shall be separated into its own chapter or file. In the event of a main inspection, the chapter or file shall be named to indicate the upstream manhole station or number and then the downstream manhole station or number (e.g. MH1-MH2). In the event of a service connection inspection, the chapter or file shall be named to indicate the house number or lot number associated with the inspection. All file naming should match the identification numbers (manhole station or number, house number, or lot number) shown on the Record Drawings. The submitted video must have the ability to be viewed using fast forward and rewind.

Any video that does not clearly show the pipe and service connections will be rejected. In the event that repairs are made, the segment receiving the repairs shall be flushed and televised again. The Engineer must oversee the entire cleaning and televising process.

Final approval of the video inspection will only be after the Engineer has reviewed the video in the office (videos will not be field approved).

Measurement and Payment:

No direct payment will be made for cleaning and video inspection, as such work will be incidental to the installation of the pipe and/or service connections.

Page 2-1, Sub-article 200-3, Construction Methods (D)

Delete the following:

Cut off and plug at the right-of-way or construction limits any private water or sewer line intercepted during the construction of the project.

Replace with the following:

Locate and do not damage any private water or sewer line intercepted during the construction of the project. Immediately repair any water or sewer line damaged during construction of the project.

Page 2-8, Sub-article 220-3, Construction Methods

Add the following:

All blasting operations will be conducted in strict conformance with the existing ordinances of the City of Winston-Salem (or any other governing authority) and accepted safe practices relative to the storage and use of explosives.

Page 3-2, Article 300-4 Preparation of Pipe Foundation:

Delete the last 2 sentences of the second paragraph.

Page 3-3, Article 300-7 Backfilling:

add the following to line 39:

Flowable fill, if approved, must not come in contact with the pipe.

Page 10-61, Sub-article 1034-2, Plastic Pipe

Delete in its entirety. City does not allow PVC pipe in its gravity sewer system and there is no force main replacement included in this project.

Page 10-61, Sub-article 1034-3, Concrete Pipe

Delete in its entirety. City does not allow new concrete pipe in its sewer system.

Page 10-61, Sub-article 1034-4, Ductile Iron Pipe, third paragraph

Add the following sentences to paragraph 2:

Rubber gasket joints shall conform to ANSI A21.11 (AWWA C111). Pipe design laying condition will be Type 2, flat-bottom trench with backfill lightly consolidated to centerline of pipe. Pipe for sanitary sewer shall be minimum thickness Class 50. Pipe for water shall be pressure Class 350 for 3" – 16" and pressure Class 250 for 18" and above.

The interior of pipe for sanitary sewer will be lined with 40 mils of ceramic epoxy. All bells and spigots for sanitary sewer pipe must be lined with a minimum of 8 mils of joint compound. The exterior of all pipe shall be coated with a bituminous coating.

For fittings, all glands shall be ductile iron, not gray iron. Fittings shall have a minimum pressure rating of 250 psi. Rubber gasket joints shall conform to ANSI A21.11 (AWWA C111). "DI" or "Ductile" shall be cast on each fitting.

The interior of fittings for sanitary sewer will be lined with 40 mils of ceramic epoxy. All bells and spigots for sanitary sewer fittings must be lined with a minimum of 8 mils of joint compound. The exterior of all fittings shall be coated with a bituminous coating. Fittings coated on the interior and exterior with 8 mils of fusion bonded epoxy in accordance with ANSI/AWWA C116 and ANSI/AWWA C550 are acceptable.

Restrained joint pipe and fittings with a gripping gasket as the only means of restraint will not be allowed.

Page 10-61, Sub-article 1034-4(B) Force Main Sewer Pipe

Delete in its entirety. There is no force main in this project.

Page 10-61, Section 1034 Sanitary Sewer Pipe and Fittings:

add the following:

1034-5 Cast Iron Soil Pipe

All cast iron soil pipe and fittings will conform to ASTM A74 and be classified as SV (service weight). Single or double hub is acceptable. No-hub pipe shall not be used. All pipe and fittings shall be uniformly coated with bituminous coating. Joints will be rubber gasket. Rubber gaskets shall conform to ASTM C564. 4" x 4" combination wye and eighth bends shall be short pattern - Fig. No. SV-32 by Charlotte Pipe and Foundry (or approved equal). 4" cleanouts shall consist of a 4" service weight cast iron ferrule (with 3" iron pipe size tap) and a 3" brass plug. The plug shall have a low raised square head (Southern Code). Cleanouts shall be Part Number 184 by Jumbo Manufacturing Company (or approved equal).

Page 10-62, Sub-article 1036-2, Copper Pipe second paragraph

Delete:

“Use flared or”

Page 10-62, Sub-article 1036-4, Steel Pipe

Delete (A) Water Pipe in its entirety. City does not allow new steel pipe in its water system.

Page 10-63, Sub-article 1036-5, Ductile Iron Pipe, third paragraph

Add the following sentences to paragraph 2:

Rubber gasket joints for pipe shall conform to ANSI A21.11 (AWWA C111). Pipe design laying condition will be Type 2, flat-bottom trench with backfill lightly consolidated to centerline of pipe. Pipe for water shall be pressure Class 350 for 3"-16".

The exterior of all pipe and fittings shall be coated with a bituminous coating.

For fittings, all glands shall be ductile iron, not gray iron. Fittings shall have a minimum pressure rating of 250 psi. Rubber gasket joints shall conform to ANSI A21.11 (AWWA C111). “DI” or “Ductile” shall be cast on each fitting.

Page 10-63, Sub-article 1036-6 Fire Hydrants

Delete the following:

“Outlets shall have national standard fire hose coupling threads. Use fire hydrants with a minimum bury length of 36”.

Add the following:

All fire hydrants shall be dry-barrel fire hydrants which comply with ANSI/AWWA C502. All hydrants will have a dry top with O-ring seals which permanently seal off the stem operating threads from water and keep the lubricant in. All hydrants shall be opened by turning the operating nut on top of the hydrant counterclockwise. The operating nut and cap nuts shall be pentagon-shaped, 1 ½” measured point to flat. The main valve shall be a compression type valve with a valve opening of 5 ¼”. Each hydrant will have two hose nozzles and one steamer nozzle. The 2 ½" hose nozzles shall have national standard threads. The steamer nozzle shall have a 5” integral Storz connection. The nozzle shall be fastened into the hydrant barrel by mechanical means, but shall not be leaded into the barrel. Nozzle caps shall be chained to the barrel. All hydrants will be furnished with a breakable traffic feature that will break upon impact. The feature shall consist of a breakable safety flange on the barrel and a breakable safety coupling in the main valve stem. Hydrants must have a bronze main valve seat ring that threads into a bronze drain ring. Each hydrant shall have at least two bronze drain outlets. All hydrants will have 6" mechanical joint base connections or the Alpha connection by American Flow Control unless otherwise specified by the Engineer. Hydrants shall be designed for a minimum working pressure of 250 psi. Assembled hydrants shall be subjected to hydrostatic tests of twice the rated

working pressure in accordance with ANSI/AWWA C502. All exterior iron surfaces below ground level shall be covered with two coats of asphaltic varnish or fusion bonded epoxy. All exterior iron surfaces above ground level shall be painted yellow to the satisfaction of the Engineer. Yellow paint shall be Rust-Oleum 7446, Rust-Oleum V2148, Kimball Midwest 80-942, or manufacturer's standard equivalent. All interior iron surfaces of the hydrant shoe which are in contact with water (including the lower valve plate and nut) shall be coated with a minimum of 8 mils of fusion bonded epoxy or liquid epoxy in accordance with ANSI/AWWA C550. All hydrants shall have a thrust or anti-friction washer in the operating area of the hydrant bonnet. A weather cap around the operating nut on top of the hydrant is required. Hydrants accepted by the City of Winston- Salem are as follows:

- (1) Super Centurion 250, manufactured by Mueller Company
- (2) B-84-B-5, manufactured by American Flow Control
- (3) K-81D Guardian, manufactured by Kennedy Valve Company
- (4) Medallion, manufactured by Clow Valve Company

Page 10-63, Sub-article 1036-7 Water Valves (A) Gate Valves

replace with the following:

All gate valves shall be resilient-seated gate valves which meet the specifications of ANSI/AWWA C509 or ANSI/AWWA C515. The valve body, bonnet and seal plate shall be coated on all exterior and interior surfaces with a minimum of 8-10 mils of fusion bonded epoxy in accordance with ANSI/AWWA C550. The valve shall incorporate a guide system with guide lugs on the wedge or on the body. The wedge shall be gray or ductile iron, fully encapsulated with rubber (including guide lugs and stem nut holder). Non-rising stem valves shall have two O-ring seals above the stem thrust collar that can be replaced with the valve under pressure. Non-rising stem valves shall also have a thrust washer on the stem thrust collar. Valves used for buried service will have a non-rising stem, mechanical joint end connections, and a 2" square operating nut. The word "OPEN" and an arrow to indicate the direction of opening the valve shall be cast on the flanged base of the operating nut. Above ground valves, unless otherwise specified, will have an outside screw and yoke rising stem or a non-rising stem, flanged end connections, and a handwheel to operate the valve. The word "OPEN" and an arrow to indicate the direction of opening the valve shall be cast on the rim of the handwheel. All valves will open by turning the nut or handwheel counterclockwise. Valves installed in manholes will normally be considered to be buried service valves and valves installed in vaults will normally be considered to be above ground valves.

Resilient-seated gate valves shall be designed for a minimum working pressure of 250 psi. Each valve shall be seat tested at the rated working pressure and shell tested at twice the rated working pressure in accordance with ANSI/AWWA C509 - Section 5 or ANSI/AWWA C515 - Section 5.

All valves shall be warranted for 10 years from date of purchase against defective materials and workmanship. Gate valves furnished under these specifications must be manufactured by one of the following or approved equal:

- (1) Clow Valve Company
- (2) M & H Valve Company
- (3) American Flow Control
- (4) U.S. Pipe and Foundry Company
- (5) Mueller Company
- (6) Kennedy Valve Company

Page 10-63, Sub-article 1036-7 (B) Bronze Gate Valves:

replace with the following:

The use of bronze gate valves shall not be permitted.

Page 10-64, Sub-article 1036-9, Service Line Valves and Fittings, Paragraph 1

Add the following:

All corporation cocks shall be made of brass. All brass fittings shall be manufactured in accordance with AWWA C800 and ASTM B-584. All brass components in contact with potable water must be made from CDA/UNS Brass Alloy C89833 with a maximum lead content of .25% by weight. Brass alloys not listed in ANSI/AWWA C800 Paragraph 4.1.2 are not approved. All fittings shall be UL classified to NSF/ANSI 61 and NSF/ANSI 372 standards and stamped or embossed with a mark or name indicating that the product is manufactured from the low-lead alloy as specified. All corporation cocks shall be of the ball valve type with AWWA inlet threads.

Page 10-64, Section 1036 Water Pipe and Fittings:

add the following:

1036-10 Retainer Glands

All retainer glands shall be wedge action glands with torque limiting twist off nuts. Glands shall be Megalug Series 1100 by EBAA Iron, Inc., Uni- Flange Series 1400 by Ford Meter Box Company, Inc., RomaGrip by Romac Industries, Inc., One-Lok Series SLDE by Sigma Corp., Stargrip Series 3000 by Star Pipe Products, Cam-Lock Series 111 by Smith-Blair, Inc., EZ Grip by SIP Industries, Tufgrip by Tyler Union, or approved equal.

1036-12 Brass Fittings

All brass fittings shall be manufactured in accordance with AWWA C800 and ASTM B-584. All

brass components in contact with potable water must be made from CDA/UNS Brass Alloy C89833 with a maximum lead content of .25% by weight. Brass alloys not listed in ANSI/AWWA C800 Paragraph 4.1.2 are not approved. All fittings shall be UL classified to NSF/ANSI 61 and NSF/ANSI 372 standards and stamped or embossed with a mark or name indicating that the product is manufactured from the low-lead alloy as specified.

Page 10-119, Article 1074-8 Steps:

replace with the following:

All manhole steps shall conform to current OSHA standards and ASTM C478. The approved step shall conform to the City of Winston-Salem detail drawing for "Polypropylene Manhole Step". All other steps must be approved by the Engineer prior to being installed.

Page 15-1, Sub-article 1500-2 Cooperation with the Utility Owner, paragraph 2:

Add the following sentences:

The utility owner is the City of Winston-Salem City/County Utilities Division (City). The contact person is Todd Lewis, PE, Senior Civil Engineer. He can be reached by phone at (336) 747-6842.

Page 15-2, Sub-article 1500-9 Placing Pipelines into Service

Add the following sentences:

Obtain approval from City prior to placing a new water line into service. Use backflow prevention assemblies for temporary connections to isolate new water lines from existing water line. A representative from City will witness all tests performed on their water facilities.

Obtain approval from City prior to placing a new sewer line into service. A representative from City will witness all tests performed on their sewer facilities.

Page 15-3, Article 1505-2 Materials:

replace line 12 with the following:

Use Class VI select material for foundation conditioning and bedding.

Page 15-4, Sub-article 1505-3 (C), Bedding:

replace the first three (3) sentences with the following:

The limits for stone bedding will normally be shown on the profile of the Engineer's drawing. Stone bedding shall have a minimum thickness beneath the pipe of four inches (4") or one-eighth of the outside diameter of the pipe, whichever is greater. The required thickness shall be determined by the Engineer.

Page 15-4, Sub-article 1505-3 (E), Thrust Restraint:

replace the fourth paragraph with the following:

Concrete thrust blocks shall be constructed as directed by the Engineer at all bends, tees, tapping sleeves, tapping saddles, reducers, plugs, etc. to provide restraint against thrust resulting from internal pressure. Any exceptions to this such as restrained joints or mechanical joints with retainer glands will be noted on the Engineer's drawings or otherwise specified. Thrust blocks will not be required for restrained joint pipe (exception - blocking will be required when connecting restrained pipe to existing pipe).

All thrust blocks will be constructed of a minimum of Class A concrete. Thrust blocks for bends, fire hydrants, tees and stub-outs shall be constructed in accordance with the City of Winston-Salem thrust block detail drawings.

Polyethylene shall be placed over all fittings before the concrete is poured. All nuts and bolts shall be clear of concrete so that the joint will be accessible. Plywood shall be used as forms for blocking. Concrete is to be poured only against stable undisturbed soil and should be allowed to set prior to any backfilling. Thrust blocks should be allowed to cure two days prior to pressure testing the water main. Higher strength concrete may be required when it is necessary to pressure test prior to the end of the two-day curing time.

Page 15-6, Sub-article 1510-3 (A) General

Replace the words "36" to 42" of cover" with "a minimum of 36" of cover".

Page 15-6, Sub-article 1510-3 (B), Testing and Sterilization

Add the following to second paragraph:

The backflow preventer must be approved by the City.

Page 15-6, Sub-article 1510-3 (B), Testing and Sterilization

Add the following to the 5th paragraph:

Prior to pressure testing and disinfection, the Contractor shall flush all water mains with a polyurethane foam pipe pig (minimum 5 pounds per cubic foot density) by Knapp Poly Pig, Inc. or approved equal. The pipe pig shall be propelled hydraulically through the mains at a rate sufficient to remove all foreign matter. Valves shall be operated in a manner which will direct the pipe pig toward the end of the main or a selected discharge point. The pig shall be removed through an open end of the main, a fitting, or through a fire hydrant which has the main valve seat ring removed. Flushing shall continue until the Engineer determines that the mains are free from all foreign matter. The Engineer must be present during the entire flushing process. Any work done without the Engineer's supervision will not be accepted.

Page 15-6, Sub-article 1510-3 (B), Testing and Sterilization

Add the following to ninth paragraph:

The Engineer must be present during the entire sterilization process. Any work done without his supervision will not be accepted. Pounds of calcium hypochlorite used for sterilization shall be

as follows:

<u>POUNDS OF CALCIUM HYPOCHLORITE REQUIRED TO STERILIZE</u>	
<u>WATER MAINS WITH 100 PARTS PER MILLION OF CHLORINE</u>	
<u>MAIN SIZE</u>	<u>POUNDS PER 1000 FEET OF PIPE</u>
2"	0.2
4"	0.8
6"	1.8
8"	3.1
12"	7.0

Page 15-6, Sub-article 1510-3 (B), Testing and Sterilization

Add the following to tenth paragraph:

The City must be notified prior to flushing. Dechlorination shall be accomplished using equipment by Pollard or approved equal. While the main is being flushed, all service connections shall be thoroughly flushed in order to disinfect each connection.

Page 15-6, Sub-article 1510-3 (B), Testing and Sterilization

Add the following paragraphs:

After final flushing and before the main is placed in service, a sample or samples shall be collected by City personnel from the line and tested for bacteriological quality. The City, upon 24 hours advance notice, will furnish the personnel and laboratory facilities to conduct the required bacteriological tests. No samples will be taken on Friday, the day before a holiday or on a holiday. The City will sample water from the pipes and test the water in their laboratory. Do not place the water lines into service until tests performed by the City are satisfactory.

Page 15-8, sub-article 1515-3(A) Valves

Add the following paragraph:

All existing valves larger than 12" that must be operated shall be operated by the City.

Page 15-8, sub-article 1515-3(B) Meters

Add the following paragraph:

For relocated meters (with change to horizontal location):
The Contractor shall install a new meter box, angle valves, yoke, tee and ball valve as directed by the Engineer. The Contractor shall expose a portion of the water line from the dwelling or business to determine the material and have proper fittings for reconnection to the new meter box. At the approval of the Engineer, the Contractor shall remove the existing meter and install it in the new yoke. The Contractor shall reconnect the property side water line from the existing meter box to the new meter box. This reconnection shall be directed by the Engineer and

performed in a timely manner so that the property is without water for a minimal amount of time.

The Contractor shall remove and dispose of the existing meter box and yoke and backfill as shown on the plans or as directed by the Engineer.

Page 15-10, Sub-article 1520-2, Materials

Delete the following:

Use screw type plastic or brass cleanouts.

Replace with the following:

Cleanouts shall be constructed of cast iron soil pipe with brass plug.

Page 15-10, Sub-article 1520-3, Construction Method

Delete third paragraph in its entirety. No PVC pipe is allowed on this project.

Page 15-10, Sub-article 1520-3, Construction Methods

Add the following to the third sentence of the fifth paragraph:

“or within fenced areas”

Page 15-10, Sub-article 1520-3, Construction Methods

Delete the following:

“10%”

Replace with the following

“18%-22%”

Page 15-10, Sub-article 1520-3, Construction Methods

Delete the seventh paragraph in its entirety.

Replace with the following:

The standard fall through manhole is 1” (0.08’) including 6” connections into a manhole.

Page 15-10, Article 1520-3 Construction Methods:

add the following:

Sewer connections shall be installed as shown on the appropriate City of Winston-Salem detail drawing. Wyes or taps will not be allowed within 5 feet of a manhole. Only one bend will be allowed for connecting the sewer connection to the sewer main. If more than one bend is needed

(Ex: bored sewer connection), the road shall be open cut and the connection installed properly.

Sewer connections shall be a maximum of 75 feet from the sewer main to the cleanout.

Cleanouts shall be installed between property corners of the lot for which the connection is intended. Connections into manholes will require a flexible sleeve at the manhole. If approved

by the Engineer, four-inch (4") connections will be allowed to spill into deep manholes. For connections which spill, the 4" pipe shall protrude a minimum of 4" and a maximum of 6" beyond the inside wall of the manhole. Connections into manholes must be at least 6" from the nearest manhole step. Six-inch (6") connections must connect into a manhole.

When installing new sewer connections intended to replace existing ones, the new sewer connection shall be of like size to the existing. Reconnection of the old connection to the new shall be performed by a qualified utility contractor or by a licensed plumbing contractor. The Contractor shall be responsible for all permits and inspections required for the reconnection.

Page 15-11, Sub-article 1520-3, Construction Methods

(A) Gravity Sanitary Sewer

Add the following to the first paragraph:

and City of Winston-Salem, North Carolina Department of Public Works Engineering Division

Page 15-11, Sub-article 1520-3, Construction Methods

(A) Gravity Sanitary Sewer (2) Testing

Delete in its entirety and replace with the following

A low-pressure air test shall be performed by the Contractor after the pipeline is completely backfilled and before being placed into service. The Engineer must be present during the entire testing process. Any work done without their supervision will not be accepted.

(a) Low Pressure Air Testing Requirements:

The Contractor shall use an approved pressure gauge and perform the test in accordance with ASTM C-828. Each section of pipeline (including connections) between manholes will be tested by plugging the upstream manhole and the downstream manhole. By using mirrors, lights, etc., the Contractor must show the Engineer that the 2 plugs are at the proper location and that the line is clear between the plugs. Air is added to the line until the pressure is between 3.0 psi and 4.0 psi. If the pressure drops more than 1.0 psi during the time shown on the chart below, the line is presumed to have failed the test. An obvious leak in any section will be corrected even if the section passes testing. The Contractor will be responsible for the complete removal of all plugs.

Air test time shall be as follows:

Minimum Air Test Time

Main Size	Time (minutes per 100 feet of pipe)
8"	1.5
10"	1.8
12"	2.1
15"	2.4
18"	2.7
21"	3.3
24"	3.9
27"	4.5
30"	5.1

(b) Video Inspection:

As a final measure required for acceptance, the Contractor shall clean and televise all sanitary sewer mains prior to requesting final inspection. The Contractor shall televise the entire sewer main and all service connections using standardized NASSCO (PACP, MACP, & LACP) practices, unless otherwise specified below. The process shall begin at the upstream manhole for each segment, and proceed to the downstream manhole for that same segment. Connections shall be televised from the cleanout to the main. Video inspection may occur only after Record Drawings are accepted and approved by the City of Winston-Salem. Prior to beginning the process, a 24 hour notice must be given by the Contractor to the Engineer. Prior to video inspection in paved areas, structures must be raised to final grade and 2" of asphalt must be in place. The City will not accept video that is more than 180 days old unless approved by the Engineer.

The cameras used for inspection shall be ones specifically designed and constructed for sanitary sewer pipeline inspection. Lighting for the cameras shall be suitable to provide a clear color picture of the entire periphery of the pipe. The cameras used for mains must be able to pan, tilt and zoom in order to allow for 360 degree viewing. The television system shall be equipped to indicate the camera travel distance in feet by display on the video viewing screen. All television equipment (camera, monitor, etc.) must be capable of producing picture quality which is satisfactory to the Engineer.

Within 2 hours of the video inspection, the Contractor shall clean the sewer mains and service connections with a high velocity water jet. All debris shall be collected in the downstream manhole and removed by the Contractor. Debris shall not be released into the existing sewer system. During the entire video process, the distance counter must be set at zero at each upstream manhole for each segment (set the counter at zero at the ground for each service connection). The Contractor will be required to pan and tilt at each manhole and at each service connection. The interior of each manhole must be marked with the manhole station (or manhole number) with paint or some other legible identifier (6" - 12" high letters or numbers). Each cleanout stack must be marked with the house number or the lot number. For mains, the Contractor will also be required to pan, tilt and zoom at all

couplings, at all dates for lined ductile iron pipe, and when any potential problems or abnormalities are noticed or suspected. Travel speed for the camera will be 15 - 30 feet per minute. The following video screen data will be required:

- Project name and project number
- Date of inspection
- Travel distance and time
- Station of start and end manholes
- Depth of start and end manholes
- Size of main
- Type of pipe

All above data shall be shown at the start and end manholes of each segment. While the camera is moving through the main and service connections, distance shall be the only data shown on the screen (top left or top right of screen).

For mains, a stream of water approximately 1" in width must be flowing during the entire video process. For service connections, a minimum of 5 gallons of water must be introduced into each cleanout stack just prior to the video process. In all cases, the flow must be shown on the bottom of the video screen.

Two copies of the entire video inspection along with a properly formatted PACP standard exchange database shall be submitted to the Engineer on a data disc (DVD or flash drive). A "properly formatted PACP standard exchange database" includes properly PACP coded defects (NASSCO version 6.x), proper media paths to associated video files, and all asset IDs used in the inspection must match what the submitted record drawings indicate for each asset. The video file shall be formatted to MPEG-4 (MP4) with software compatible and readable by the City of Winston-Salem. The City of Winston-Salem shall not be responsible for purchasing additional software necessary to view the video file. Each inspection (manhole to manhole or cleanout to main) shall be separated into its own chapter or file. In the event of a main inspection, the chapter or file shall be named to indicate the upstream manhole station or number and then the downstream manhole station or number (e.g. MH1-MH2). In the event of a service connection inspection, the chapter or file shall be named to indicate the house number or lot number associated with the inspection. All file naming should match the identification numbers (manhole station or number, house number, or lot number) shown on the Record Drawings. The submitted video must have the ability to be viewed using fast forward and rewind.

Any video that does not clearly show the pipe and service connections will be rejected. In the event that repairs are made, the segment receiving the repairs shall be flushed and televised again. The Engineer must oversee the entire cleaning and televising process. Final approval of the video inspection will only be after the Engineer has reviewed the video in the office (videos will not be field approved).

No direct payment will be made for cleaning and video inspection, as such work will be incidental to the installation of the pipe and/or service connections.

Page 15-14, Sub-article 1525-2, Materials

First paragraph, add the following after the second sentence:

All manhole joints shall be sealed on the outside of the manhole with butyl adhesive tape (minimum 6" wide). When unstable subgrade is encountered, manholes shall be bedded on stabilization stone.

Page 15-14, Sub-article 1525-2, Materials

First paragraph, delete third sentence in its entirety.

Replace with the following:

Flexible manhole connectors shall conform to ASTM C923.

Page 15-14, Article 1525-2, Materials, line 10:

add the following:

Connectors shall be manufactured by Press-Seal Gasket Corporation, Hamilton Kent, NPC Inc. or approved equal.

Page 15-14, Article 1525-2, Materials, lines 12-16:

replace with the following:

Type 1 manhole rings and covers will be made of cast iron and will conform to ASTM A48, Class 35B. In addition, all manhole rings and covers shall be designed to support an H-20 wheel load. All castings will conform to the shape and dimensions shown on the City of Winston-Salem detail drawing for "Manhole Ring and Cover (Type 1)" and will be free from holes, cracks or any other defects. Rings and covers will have machined seats so that the cover will not rattle. Rings will weigh a minimum of 190 pounds and covers a minimum of 120 pounds. The name of the manufacturer and the part number shall be cast permanently on the ring and the cover. Castings that do not meet specifications shall be rejected.

Page 15-14, Sub-article 1525-3, Construction Methods

Second paragraph, first sentence, delete the following:

"resilient"

Replace with the following:

"flexible"

Delete the second and third sentences in their entirety.

Page 15-14, Sub-article 1525-3, Construction Methods

Fifth paragraph, fourth sentence, delete the following:

“recommended but not required”

Replace with the following:

“required”

Page 15-15, Sub-Article 1525-3 (D), Testing:

replace with the following:

Each manhole constructed by the Contractor shall be vacuum tested by the Contractor after assembly of the manhole. Prior to testing, and as directed by the Engineer, the Contractor shall clean out each manhole without foreign material being discharged into the existing sanitary sewer system. The test shall be conducted in accordance with ASTM C-1244. The test shall be performed after all grade rings and rings and covers have been installed. After the testing equipment is in place, a vacuum of 10 inches of mercury shall be drawn on the manhole. The time for the vacuum to drop to 9 inches of mercury must be greater than the minimum time listed below:

Minimum Vacuum Test Time (Seconds)

Manhole Depth	Diameter of Manhole		
	4'	5'	6'
0 - 10'	60 sec.	75 sec.	90 sec.
10 - 5'	75 sec.	90 sec.	105 sec.
15 - 25'	90 sec.	105 sec.	120 sec.
25 - 30'	105 sec.	120 sec.	135 sec.

The Engineer shall be present during the entire testing process. Any subsequent repairs to manholes which fail the vacuum test must be made on the inside and outside of each manhole. The Contractor will be responsible for the complete removal of all plugs.

No direct payment will be made for vacuum testing of manholes, as such work will be incidental to the installation of the manhole.

Page 15-16, sub-article 1530-3(A) Abandoning Pipe,

Add the following paragraph:

When abandoning water mains up to a main that is to remain in service, any valve or tee associated with the main to be abandoned shall be removed. A sleeve and any necessary piping shall be installed to reconnect the water main to remain in service. All other main line valves on abandoned water mains that are plugged and left in place shall be abandoned by removing the valve box. Hydrants connected to abandoned mains that are plugged and left in place shall

also be abandoned by removing the hydrant and valve box. The work covered in this paragraph shall be considered incidental to the abandonment.

Page 15-17, Sub-article 1530-3 (C), Remove Water Meter:

replace the first sentence with the following:

Remove water meter by closing the corporation cock at the main and removing the lateral including the angle valve, setter and meter box.

Page 15-18, Article 1540-2, Materials:

add the following:

Item	Section
Casing Spacers	1036-10

Page 15-18, Sub-article 1540-3 (D), Carrier Pipe Installation, lines 16-18:

replace with the following:

Carrier pipe installed through encasement shall be ductile iron flexible restrained joint pipe. Casing spacers are required and shall be placed at 10 foot intervals within the encasement. One spacer shall be placed not more than 2 feet from each end of the encasement. Only the runners of the casing spacer shall be in contact with the encasement. The bell of the carrier pipe will not be allowed to be in contact with the encasement. The Engineer must be present to observe the entire installation of the carrier pipe.

Product List

Hydrants accepted by the City of Winston-Salem are as follows:

- (1) Super Centurion 250, manufactured by Mueller Company
- (2) B-84-B-5, manufactured by American Flow Control
- (3) K -81D Guardian, manufactured by Kennedy Valve Company
- (4) Medallion , Manufactured by Clow Valve Company

Gate valves furnished under these specifications must be manufactured by one of the following:

- (1) Clow Valve Company
- (2) M & H Valve Company
- (3) American Flow Control
- (4) U.S. Pipe and Foundry Company
- (5) Mueller Company

(6) Kennedy Valve Company

Approved tapping saddles are as follows:

- (1) American Flow Control
- (2) U.S. Pipe and Foundry Company

Approved tapping sleeves are as follows:

- (1) Mueller Company
- (2) American Flow Control
- (3) Tyler Pipe Company
- (4) U.S. Pipe and Foundry Company
- (5) Kennedy Valve Company

Approved tapping valves are as follows:

- (1) Clow Valve Company
- (2) M & H Valve Company
- (3) American Flow Control
- (4) U.S. Pipe and Foundry Company
- (5) Mueller Company
- (6) Kennedy Valve Company

All corporation cocks shall be: 3/4", 1", 1 1/2" and 2"- FB1000-G by Ford or 74701BT by McDonald

Saddles shall be Model 202SSU by Romac Industries, Inc. or Model F202-SSB by Ford
Ductile iron flexible restrained joint pipe and fittings accepted by the City of Winston-Salem are as follows:

- (1) Flex Ring by American
- (2) TRFlex by US Pipe
- (3) TR Flex by McWane

Approved flexible manhole connectors are as follows:

- (1) Press-Seal Gasket Corporation
- (2) Hamilton Kent

Approved manhole rings and covers are as follows:

- (1) East Jordan Iron Works
- (2) U.S. Foundry & Manufacturing Corp.

All interior linings for a sewer ductile iron pipe, restrained joint ductile iron and fittings shall be a Ceramic Epoxy. The material shall be an amine cured novalac epoxy containing at least 20% by volume

of ceramic quartz pigment. The lined pipe shall pass testing in compliance with ASTM E-96 Procedure A with a test duration of 30 days and a permeability rating of 0.00. Other testing shall be in compliance with ASTM B-117 Salt Spray with 0.0 undercutting after 2 years, ASTM G-95 with results less than 0.5 mm undercutting after 30 days, and ASTM D-714 with no affect after 2 years.

PROJECT SPECIAL PROVISIONS
Utilities by Others



120 N. Boylan Avenue
Raleigh, NC 27603
(919) 828-0531
License Number: F-0115

General:

The following utility companies have facilities which are in conflict with the construction of this project:

- A) Duke Energy Distribution
- B) AT&T Communications-Local Service
- C) MCI/Verizon
- D) Level 3
- E) Segra
- F) Windstream Communications
- G) Piedmont Natural Gas
- H) Spectrum

The conflicting facilities of these companies will be adjusted/relocated by the date of **January 31, 2024**, unless otherwise noted and are therefore listed in these special provisions for the benefit of the Contractor. All utility work listed herein will be done by the utility owners. All utilities are shown on the plans from the best available information.

The Contractor's attention is directed to Article 105-8 of the 2018 Standard Specifications.

Utilities Requiring Adjustment:

Utility relocations are shown on the Utilities by Others Plans.

A) Duke Energy – Distribution Power

- 1) Duke Energy will remove and replace its facilities within the project limits as shown on the Project UBO Drawings.
- 2) Contact Person: Mr. Larry Robinson, 803-203-2239, larry.robinson2@duke-energy.com

PROJECT SPECIAL PROVISIONS

Utilities by Others

B) AT&T Communications- Local Service

- 1) AT&T will abandon and replace its facilities within the project limits as shown on the Project UBO Drawings.
- 2) Contact Person: Mr. Will Pace, 336-391-4843, wp678r@att.com

C) MCI/Verizon - Communication

- 1) MCI/Verizon will abandon and replace its facilities within the project limits as shown on the Project UBO Drawings.
- 2) Contact Person: Leon Jones, 336-289-8847 leon.jones@verizon.com

D) Level 3 - Communication

- 1) Level 3 will abandon and replace its facilities within the project limits as shown on the Project UBO Drawings.
- 2) Contact Person: Mr. Taylor Harmon, 704-640-8971
tharmon@sourceonecorp.com

E) Segra - Communication

- 1) Segra will abandon and replace its facilities within the project limits as shown on the Project UBO Drawings.
- 2) Contact Person: Mr. Justin Calloway, 336-285-7497,
justin@tprcbroadband.com

F) Windstream Communication

- 1) Windstream Communication will abandon and replace its facilities within the project limits as shown on the Project UBO Drawings.
- 2) Contact Person: Mr. Maxx Curtis, 704-961-6700, maxx.curtis@byers.com

PROJECT SPECIAL PROVISIONS

Utilities by Others

G) Piedmont Natural Gas

1. PNG will abandon and replace its facilities within the project limits as shown on the Project UBO Drawings.
2. Contact Person: Mr. Kenneth State, 336-403-9984, kenneth.state@duke-energy.com

H) Spectrum - Communication

1. Spectrum will abandon and replace its facilities within the project limits as shown on the Project UBO Drawings.
2. Contact Person: Mr. Scottie Chilton, 336-451-9092, scottie.chilton@charter.com

STABILIZATION REQUIREMENTS:

(3-11-2016)

Stabilization for this project shall comply with the time frame guidelines as specified by the NCG-010000 general construction permit effective April 1, 2019 issued by the North Carolina Department of Environmental Quality Division of Water Resources. Temporary or permanent ground cover stabilization shall occur within 7 calendar days from the last land-disturbing activity, with the following exceptions in which temporary or permanent ground cover shall be provided in 14 calendar days from the last land-disturbing activity:

- Slopes between 2:1 and 3:1, with a slope length of 10 ft. or less
- Slopes 3:1 or flatter, with a slope of length of 50 ft. or less
- Slopes 4:1 or flatter

The stabilization timeframe for High Quality Water (HQW) Zones shall be 7 calendar days with no exceptions for slope grades or lengths. High Quality Water Zones (HQW) Zones are defined by North Carolina Administrative Code 15A NCAC 04A.0105 (25). Temporary and permanent ground cover stabilization shall be achieved in accordance with the provisions in this contract and as directed.

SEEDING AND MULCHING:

(West)

The kinds of seed and fertilizer, and the rates of application of seed, fertilizer, and limestone, shall be as stated below. During periods of overlapping dates, the kind of seed to be used shall be determined. All rates are in pounds per acre.

Shoulder and Median Areas

August 1 - June 1		May 1 - September 1	
20#	Kentucky Bluegrass	20#	Kentucky Bluegrass
75#	Hard Fescue	75#	Hard Fescue
25#	Rye Grain	10#	German or Browntop Millet
500#	Fertilizer	500#	Fertilizer
4000#	Limestone	4000#	Limestone

Areas Beyond the Mowing Pattern, Waste and Borrow Areas:

August 1 - June 1		May 1 - September 1	
100#	Tall Fescue	100#	Tall Fescue
15#	Kentucky Bluegrass	15#	Kentucky Bluegrass
30#	Hard Fescue	30#	Hard Fescue
25#	Rye Grain	10#	German or Browntop Millet
500#	Fertilizer	500#	Fertilizer
4000#	Limestone	4000#	Limestone

Approved Tall Fescue Cultivars

06 Dust	Escalade	Justice	Serengeti
2 nd Millennium	Essential	Kalahari	Shelby
3 rd Millennium	Evergreen 2	Kitty Hawk 2000	Sheridan
Apache III	Falcon IV	Legitimate	Signia
Avenger	Falcon NG	Lexington	Silver Hawk
Barlexas	Falcon V	LSD	Sliverstar
Barlexas II	Faith	Magellan	Shenandoah Elite
Bar Fa	Fat Cat	Matador	Sidewinder
Barrera	Festnova	Millennium SRP	Skyline
Barrington	Fidelity	Monet	Solara
Barrobusto	Finelawn Elite	Mustang 4	Southern Choice II
Barvado	Finelawn Xpress	Ninja 2	Speedway
Biltmore	Finesse II	Ol' Glory	Spyder LS
Bingo	Firebird	Olympic Gold	Sunset Gold
Bizem	Firecracker LS	Padre	Taccoa
Blackwatch	Firenza	Patagonia	Tanzania
Blade Runner II	Five Point	Pedigree	Trio
Bonsai	Focus	Picasso	Tahoe II
Braveheart	Forte	Piedmont	Talladega
Bravo	Garrison	Plantation	Tarheel
Bullseye	Gazelle II	Proseeds 5301	Terrano
Cannavaro	Gold Medallion	Prospect	Titan Ltd
Catalyst	Grande 3	Pure Gold	Titanium LS
Cayenne	Greenbrooks	Quest	Tracer
Cessane Rz	Greenkeeper	Raptor II	Traverse SRP
Chipper	Gremlin	Rebel Exeda	Tulsa Time
Cochise IV	Greystone	Rebel Sentry	Turbo
Constitution	Guardian 21	Rebel IV	Turbo RZ
Corgi	Guardian 41	Regiment II	Tuxedo RZ
Corona	Hemi	Regenerate	Ultimate
Coyote	Honky Tonk	Rendition	Venture
Darlington	Hot Rod	Rhambler 2 SRP	Umbrella
Davinci	Hunter	Rembrandt	Van Gogh
Desire	Inferno	Reunion	Watchdog
Dominion	Innovator	Riverside	Wolfpack II
Dynamic	Integrity	RNP	Xtremegreen
Dynasty	Jaguar 3	Rocket	
Endeavor	Jamboree	Scorpion	

Approved Kentucky Bluegrass Cultivars:

4-Season	Blue Velvet	Gladstone	Quantum Leap
Alexa II	Blueberry	Granite	Rambo
America	Boomerang	Hampton	Rhapsody
Apollo	Brilliant	Harmonie	Rhythm

Arcadia	Cabernet	Impact	Rita
Aries	Champagne	Jefferson	Royce
Armada	Champlain	Juliet	Rubicon
Arrow	Chicago II	Jump Start	Rugby II
Arrowhead	Corsair	Keeneland	Shiraz
Aura	Courtyard	Langara	Showcase
Avid	Delight	Liberator	Skye
Award	Diva	Madison	Solar Eclipse
Awesome	Dynamo	Mercury	Sonoma
Bandera	Eagleton	Midnight	Sorbonne
Barduke	Emblem	Midnight II	Starburst
Barnique	Empire	Moon Shadow	Sudden Impact
Baroness	Envicta	Moonlight SLT	Total Eclipse
Barrister	Everest	Mystere	Touche
Barvette HGT	Everglade	Nu Destiny	Tsunami
Bedazzled	Excursion	NuChicago	Unique
Belissimo	Freedom II	NuGlade	Valor
Bewitched	Freedom III	Odyssey	Voyager II
Beyond	Front Page	Perfection	Washington
Blacksburg II	Futurity	Pinot	Zinfandel
Blackstone	Gaelic	Princeton 105	
Blue Note	Ginney II	Prosperity	

Approved Hard Fescue Cultivars:

Aurora II	Eureka II	Oxford	Scaldis II
Aurora Gold	Firefly	Reliant II	Spartan II
Berkshire	Granite	Reliant IV	Stonehenge
Bighorn GT	Heron	Rescue 911	
Chariot	Nordic	Rhino	

On cut and fill slopes 2:1 or steeper add 20# Sericea Lespedeza January 1 - December 31.

Fertilizer shall be 10-20-20 analysis. A different analysis of fertilizer may be used provided the 1-2-2 ratio is maintained and the rate of application adjusted to provide the same amount of plant food as a 10-20-20 analysis and as directed.

TEMPORARY SEEDING:

Fertilizer shall be the same analysis as specified for *Seeding and Mulching* and applied at the rate of 400 pounds and seeded at the rate of 50 pounds per acre. German Millet, or Browntop Millet shall be used in summer months and rye grain during the remainder of the year. The Engineer will determine the exact dates for using each kind of seed.

FERTILIZER TOPDRESSING:

Fertilizer used for topdressing shall be 16-8-8 grade and shall be applied at the rate of 500 pounds per acre. A different analysis of fertilizer may be used provided the 2-1-1 ratio is maintained and the rate of application adjusted to provide the same amount of plant food as 16-8-8 analysis and as directed.

SUPPLEMENTAL SEEDING:

The kinds of seed and proportions shall be the same as specified for *Seeding and Mulching*, and the rate of application may vary from 25# to 75# per acre. The actual rate per acre will be determined prior to the time of topdressing and the Contractor will be notified in writing of the rate per acre, total quantity needed, and areas on which to apply the supplemental seed. Minimum tillage equipment, consisting of a sod seeder shall be used for incorporating seed into the soil as to prevent disturbance of existing vegetation. A clodbuster (ball and chain) may be used where degree of slope prevents the use of a sod seeder.

MOWING:

The minimum mowing height on this project shall be six inches.

RESPONSE FOR EROSION CONTROL:

Description

Furnish the labor, materials, tools and equipment necessary to move personnel, equipment, and supplies to the project necessary for the pursuit of any or all of the following work as shown herein, by an approved subcontractor.

Section	Erosion Control Item	Unit
1605	Temporary Silt Fence	LF
1606	Special Sediment Control Fence	LF/TON
1615	Temporary Mulching	ACR
1620	Seed - Temporary Seeding	LB
1620	Fertilizer - Temporary Seeding	TN
1631	Matting for Erosion Control	SY
SP	Coir Fiber Mat	SY
1640	Coir Fiber Baffles	LF
SP	Permanent Soil Reinforcement Mat	SY
1660	Seeding and Mulching	ACR
1661	Seed - Repair Seeding	LB
1661	Fertilizer - Repair Seeding	TON

1662	Seed - Supplemental Seeding	LB
1665	Fertilizer Topdressing	TON
SP	Safety/Highly Visible Fencing	LF
SP	Response for Erosion Control	EA

Construction Methods

Provide an approved subcontractor who performs an erosion control action as described in the NPDES Inspection Form SPPP30. Each erosion control action may include one or more of the above work items.

Measurement and Payment

Response for Erosion Control will be measured and paid for by counting the actual number of times the subcontractor moves onto the project, including borrow and waste sites, and satisfactorily completes an erosion control action described in Form 1675. The provisions of Article 104-5 of the *Standard Specifications* will not apply to this item of work.

Payment will be made under:

Pay Item

Response for Erosion Control

Pay Unit

Each

MINIMIZE REMOVAL OF VEGETATION:

The Contractor shall minimize removal of vegetation within project limits to the maximum extent practicable. Vegetation along stream banks and adjacent to other jurisdictional resources outside the construction limits shall only be removed upon approval of Engineer. No additional payment will be made for this minimization work.

STOCKPILE AREAS:

The Contractor shall install and maintain erosion control devices sufficient to contain sediment around any erodible material stockpile areas as directed.

ACCESS AND HAUL ROADS:

At the end of each working day, the Contractor shall install or re-establish temporary diversions or earth berms across access/haul roads to direct runoff into sediment devices. Silt fence sections that are temporarily removed shall be reinstalled across access/haul roads at the end of each working day.

CONSTRUCTION MATERIALS MANAGEMENT

(3-19-19) (rev. 04-27-20)

Description

The requirements set forth shall be adhered to in order to meet the applicable materials handling requirements of the NCG010000 permit. Structural controls installed to manage construction materials stored or used on site shall be shown on the E&SC Plan. Requirements for handling materials on construction sites shall be as follows:

Polyacrylamides (PAMS) and Flocculants

Polyacrylamides (PAMS) and flocculants shall be stored in leak-proof containers that are kept under storm-resistant cover or surrounded by secondary containment structures designed to protect adjacent surface waters. PAMS or other flocculants used shall be selected from the NC DWR List of Approved PAMS/Flocculants. The concentration of PAMS and other flocculants used shall not exceed those specified in the NC DWR List of Approved PAMS/Flocculants and in accordance with the manufacturer's instructions. The NC DWR List of Approved PAMS/Flocculants is available at:

https://files.nc.gov/ncdeq/Water+Quality/Environmental+Sciences/ATU/PAM8_30_18.pdf

Equipment Fluids

Fuels, lubricants, coolants, and hydraulic fluids, and other petroleum products shall be handled and disposed of in a manner so as not to enter surface or ground waters and in accordance with applicable state and federal regulations. Equipment used on the site must be operated and maintained properly to prevent discharge of fluids. Equipment, vehicle, and other wash waters shall not be discharged into E&SC basins or other E&SC devices. Alternative controls should be provided such that there is no discharge of soaps, solvents, or detergents.

Waste Materials

Construction materials and land clearing waste shall be disposed of in accordance with North Carolina General Statutes, Chapter 130A, Article 9 - Solid Waste Management, and rules governing the disposal of solid waste (15A NCAC 13B). Areas dedicated for managing construction material and land clearing waste shall be at least 50 feet away from storm drain inlets and surface waters unless it can be shown that no other alternatives are reasonably available. Paint and other liquid construction material waste shall not be dumped into storm drains. Paint and other liquid construction waste washouts should be located at least 50 feet away from storm drain inlets unless there is no alternative. Other options are to install lined washouts or use portable, removable bags or bins. Hazardous or toxic waste shall be managed in accordance with the federal Resource Conservation and Recovery Act (RCRA) and NC Hazardous Waste Rules at 15A NCAC, Subchapter 13A. Litter and sanitary waste shall be managed in a manner to prevent it from entering jurisdictional waters and shall be disposed of offsite.

Herbicide, Pesticide, and Rodenticides

Herbicide, pesticide, and rodenticides shall be stored and applied in accordance with the Federal Insecticide, Fungicide, and Rodenticide Act, North Carolina Pesticide Law of 1971 and labeling restrictions.

Concrete Materials

Concrete materials onsite, including excess concrete, must be controlled and managed to avoid contact with surface waters, wetlands or buffers. No concrete or cement slurry shall be discharged from the site. (Note that discharges from onsite concrete plants require coverage under a separate NPDES permit – NCG140000.) Concrete wash water shall be managed in accordance with the *Concrete Washout Structure* provision. Concrete slurry shall be managed and disposed of in accordance with *NCDOT DGS and HOS DCAR Distribution of Class A Residuals Statewide* (Permit No. WQ0035749). Any hardened concrete residue will be disposed of, or recycled on site, in accordance with state solid waste regulations.

Earthen Material Stock Piles

Earthen material stock piles shall be located at least 50 feet away from storm drain inlets and surface waters unless it can be shown that no other alternatives are reasonably available.

Measurement and Payment

Conditions set within the *Construction Materials Management* provision are incidental to the project for which no direct compensation will be made.

WASTE AND BORROW SOURCES:

(2-16-11) (Rev. 3-17-22)

Payment for temporary erosion control measures, except those made necessary by the Contractor's own negligence or for his own convenience, will be paid for at the appropriate contract unit price for the devices or measures utilized in borrow sources and waste areas.

No additional payment will be made for erosion control devices or permanent seeding and mulching in any commercial borrow or waste pit. All erosion and sediment control practices that may be required on a commercial borrow or waste site will be done at the Contractor's expense.

All offsite Staging Areas, Borrow and Waste sites shall be in accordance with "Borrow and Waste Site Reclamation Procedures for Contracted Projects" located at:

<https://connect.ncdot.gov/resources/roadside/FieldOperationsDocuments/Contract%20Reclamation%20Procedures.pdf>

All forms and documents referenced in the "Borrow and Waste Site Reclamation Procedures for Contracted Projects" shall be included with the reclamation plans for offsite staging areas, and borrow and waste sites.

TEMPORARY DIVERSION:

This work consists of installation, maintenance, and cleanout of *Temporary Diversions* in accordance with Section 1630 of the *Standard Specifications*. The quantity of excavation for installation and cleanout will be measured and paid for as *Silt Excavation* in accordance with Article 1630-3 of the *Standard Specifications*.

SAFETY FENCE AND JURISDICTIONAL FLAGGING:**Description**

Safety Fence shall consist of furnishing materials, installing and maintaining polyethylene or polypropylene fence along the outside riparian buffer, wetland, or water boundary, or other boundaries located within the construction corridor to mark the areas that have been approved to infringe within the buffer, wetland, endangered vegetation, culturally sensitive areas or water. The fence shall be installed prior to any land disturbing activities.

Interior boundaries for jurisdictional areas noted above shall be delineated by stakes and highly visible flagging.

Jurisdictional boundaries at staging areas, waste sites, or borrow pits, whether considered outside or interior boundaries shall be delineated by stakes and highly visible flagging.

Materials**(A) Safety Fencing**

Polyethylene or polypropylene fence shall be a highly visible preconstructed safety fence approved by the Engineer. The fence material shall have an ultraviolet coating.

Either wood posts or steel posts may be used. Wood posts shall be hardwood with a wedge or pencil tip at one end, and shall be at least 5 ft. in length with a minimum nominal 2" x 2" cross section. Steel posts shall be at least 5 ft. in length, and have a minimum weight of 0.85 lb/ft of length.

(B) Boundary Flagging

Wooden stakes shall be 4 feet in length with a minimum nominal 3/4" x 1-3/4" cross section. The flagging shall be at least 1" in width. The flagging material shall be vinyl and shall be orange in color and highly visible.

Construction Methods

No additional clearing and grubbing is anticipated for the installation of this fence. The fence shall be erected to conform to the general contour of the ground.

(A) Safety Fencing

Posts shall be set at a maximum spacing of 10 ft., maintained in a vertical position and hand set or set with a post driver. Posts shall be installed a minimum of 2 ft. into the ground. If hand set, all backfill material shall be thoroughly tamped. Wood posts may be sharpened to a dull point if power driven. Posts damaged by power driving shall be removed and replaced prior to final acceptance. The tops of all wood posts shall be cut at a 30-degree angle. The wood posts may, at the option of the Contractor, be cut at this angle either before or after the posts are erected.

The fence geotextile shall be attached to the wood posts with one 2" galvanized wire staple across each cable or to the steel posts with wire or other acceptable means.

Place construction stakes to establish the location of the safety fence in accordance with Article 105-9 or Article 801-1 of the *Standard Specifications*. No direct pay will be made for the staking of the safety fence. All stakeouts for safety fence shall be considered incidental to the work being paid for as "Construction Surveying", except that where there is no pay item for construction surveying, all safety fence stakeout will be performed by state forces.

The Contractor shall be required to maintain the safety fence in a satisfactory condition for the duration of the project as determined by the Engineer.

(B) Boundary Flagging

Boundary flagging delineation of interior boundaries shall consist of wooden stakes on 25 feet maximum intervals with highly visible orange flagging attached. Stakes shall be installed a minimum of 6" into the ground. Interior boundaries may be staked on a tangent that runs parallel to buffer but must not encroach on the buffer at any location. Interior boundaries of hand clearing shall be identified with a different colored flagging to distinguish it from mechanized clearing.

Boundary flagging delineation of interior boundaries will be placed in accordance with Article 105-9 or Article 801-1 of the *Standard Specifications*. No direct pay will be made for delineation of the interior boundaries. This delineation will be considered incidental to the work being paid for as *Construction Surveying*, except that where there is no pay item or construction surveying the cost of boundary flagging delineation shall be included in the unit prices bid for the various items in the contract. Installation for delineation of all jurisdictional boundaries at staging areas, waste sites, or borrow pits shall consist of wooden stakes on 25 feet maximum intervals with highly visible orange flagging attached. Stakes shall be installed a minimum of 6" into the ground. Additional flagging may be placed on overhanging vegetation to enhance visibility but does not substitute for installation of stakes.

Installation of boundary flagging for delineation of all jurisdictional boundaries at staging areas, waste sites, or borrow pits shall be performed in accordance with Subarticle 230-4(B)(5) or Subarticle 802-2(F) of the *Standard Specifications*. No direct pay will be made for this delineation, as the cost of same shall be included in the unit prices bid for the various items in the contract.

The Contractor shall be required to maintain alternative stakes and highly visible flagging in a satisfactory condition for the duration of the project as determined by the Engineer.

Measurement and Payment

Safety Fence will be measured and paid as the actual number of linear feet of polyethylene or polypropylene fence installed in place and accepted. Such payment will be full compensation including but not limited to furnishing and installing fence geotextile with necessary posts and post bracing, staples, tie wires, tools, equipment and incidentals necessary to complete this work.

Payment will be made under:

Pay Item	Pay Unit
Safety Fence	Linear Foot

PERMANENT SOIL REINFORCEMENT MAT:

Description

This work consists of furnishing and placing *Permanent Soil Reinforcement Mat*, of the type specified, over previously prepared areas as directed.

Materials

The product shall be a permanent erosion control reinforcement mat and shall be constructed of synthetic or a combination of coconut and synthetic fibers evenly distributed throughout the mat between a bottom UV stabilized netting and a heavy duty UV stabilized top net. The matting shall be stitched together with UV stabilized polypropylene thread to form a permanent three-dimensional structure. The mat shall have the following minimum physical properties:

Property	Test Method	Value	Unit
Light Penetration	ASTM D6567	9	%
Thickness	ASTM D6525	0.40	in
Mass Per Unit Area	ASTM D6566	0.55	lb/sy
Tensile Strength	ASTM D6818	385	lb/ft
Elongation (Maximum)	ASTM D6818	49	%
Resiliency	ASTM D1777	>70	%
UV Stability *	ASTM D4355	≥80	%
Porosity (Permanent Net)	ECTC Guidelines	≥85	%
Maximum Permissible Shear Stress (Vegetated)	Performance Bench Test	≥8.0	lb/ft ²
Maximum Allowable Velocity (Vegetated)	Performance Bench Test	≥16.0	ft/s

*ASTM D1682 Tensile Strength and % strength retention of material after 1000 hours of exposure.

Submit a certification (Type 1, 2, or 3) from the manufacturer showing:

- (A) the chemical and physical properties of the mat used, and
- (B) conformance of the mat with this specification.

Construction Methods

Matting shall be installed in accordance with Subarticle 1631-3(B) of the *Standard Specifications*.

All areas to be protected with the mat shall be brought to final grade and seeded in accordance with Section 1660 of the *Standard Specifications*. The surface of the soil shall be smooth, firm, stable and free of rocks, clods, roots or other obstructions that would prevent the mat from lying in direct contact with the soil surface. Areas where the mat is to be placed will not need to be mulched.

Measurement and Payment

Permanent Soil Reinforcement Mat will be measured and paid for as the actual number of square yards measured along the surface of the ground over which Permanent Soil Reinforcement Mat is installed and accepted. Overlaps will not be included in the measurement, and will be considered as incidental to the work. Such payment shall be full compensation for furnishing and installing the mat, including overlaps, and for all required maintenance.

Payment will be made under:

Pay Item

Permanent Soil Reinforcement Mat

Pay Unit

Square Yard

SKIMMER BASIN WITH BAFFLES:

Description

Provide a skimmer basin to remove sediment from construction site runoff at locations shown in the erosion control plans. See the Skimmer Basin with Baffles Detail sheet provided in the erosion control plans. Work includes constructing sediment basin, installation of temporary slope drain pipe and coir fiber baffles, furnishing, installation and cleanout of skimmer, providing and placing stone pad on bottom of basin underneath skimmer device, providing and placing a geotextile spillway liner, providing coir fiber mat stabilization for the skimmer outlet, disposing of excess materials, removing temporary slope drain, coir fiber baffles, geotextile liner and skimmer device, backfilling basin area with suitable material and providing proper drainage when basin area is abandoned.

Materials

Item

Section

Stone for Erosion Control, Class B	1042
Geotextile for Soil Stabilization, Type 4	1056
Fertilizer for Temporary Seeding	1060-2
Seed for Temporary Seeding	1060-4
Seeding and Mulching	1060-4
Matting for Erosion Control	1060-8
Staples	1060-8
Coir Fiber Mat	1060-14
Temporary Slope Drain	1622-2
Coir Fiber Baffle	1640

Provide appropriately sized and approved skimmer device.

Provide Schedule 40 PVC pipe with a length of 6 ft. to attach to the skimmer and the coupling connection to serve as the arm pipe. For skimmer sizes of 2.5 in. and smaller, the arm pipe diameter shall be 1.5 inches. For skimmer sizes of 3 in. and larger, refer to manufacturer recommendation.

Provide 4" diameter Schedule 40 PVC pipe to attach to coupling connection of skimmer to serve as the barrel pipe through the earthen dam.

Anchors: Staples, stakes, or reinforcement bars shall be used as anchors.

Wooden Stakes:

Provide hardwood stakes 12"- 24" long with a 2" x 2" nominal square cross section. One end of the stake must be sharpened or beveled to facilitate driving through the coir fiber mat and down into the underlying soil. The other end of the stake needs to have a 1"- 2" long head at the top with a 1"- 2" notch following to catch and secure the coir fiber mat.

Steel Reinforcement Bars:

Provide uncoated #10 steel reinforcement bars 24" nominal length. The bars shall have a 4" diameter bend at one end with a 4" straight section at the tip to catch and secure the coir fiber mat.

Staples:

Provide staples made of 0.125" diameter new steel wire formed into a *u* shape not less than 12" in length with a throat of 1" in width.

Construction Methods

Excavate basin according to the erosion control plans with basin surface free of obstructions, debris, and pockets of low-density material. Install temporary slope drain pipe and construct the primary spillway according to the Skimmer Basin with Baffles Detail sheet in the erosion control plans. Temporary slope drain pipe at inlet of basin may be replaced by geotextile as directed.

Construct the coir fiber baffles according to *Roadway Standard Drawings* No. 1640.01 and Section 1640 of the *Standard Specifications*.

Install skimmer device according to manufacturer recommendations. Install 4" Schedule 40 PVC pipe into dam on the lower side of basin 1 ft. from the bottom of the basin and according to the detail, and extend the pipe so the basin will drain. Attach a 6 ft. arm pipe to the coupling connection and skimmer according to manufacturer recommendations. The coupling shall be rigid and non-buoyant and not exceed a diameter of 4" and 12" in length. Attach the rope included with the skimmer to the tee between the vent socket and the tube inlet, and the other end to a wooden stake or metal post. Clean out skimmer device when it becomes clogged with sediment and/or debris and is unable to float at the top of water in skimmer basin. Take appropriate measures to avoid ice accumulation in the skimmer device. Construct a stone pad of Class B stone directly underneath the skimmer device at bottom of basin. The pad shall be a minimum of 12" in height, and shall have a minimum cross sectional area of 4 ft. by 4 ft.

Line primary spillway with geotextile unrolled in the direction of flow and lay smoothly but loosely on soil surface without creases. Bury edges of geotextile in a trench at least 5" deep and tamp firmly. If geotextile for the primary spillway is not one continuous piece of material, make horizontal overlaps a minimum of 18" with upstream geotextile overlapping the downstream geotextile. Secure geotextile with eleven gauge wire staples shaped into a *u* shape with a length of not less than 12" and a throat not less than 1" in width. Place staples along outer edges and throughout the geotextile a maximum of 3 ft. horizontally and vertically. Geotextile shall be placed to the bottom and across the entire width of the basin according to the Skimmer Basin with Baffles detail. Place sealant inside basin around barrel pipe on top of geotextile with a minimum width of 6 in.

At the skimmer outlet, provide a smooth soil surface free from stones, clods, or debris that will prevent contact of the coir fiber matting with the soil. Unroll the matting and apply without stretching such that it will lie smoothly but loosely on the soil surface. Wooden stakes, reinforcement bars, or staples may be used as anchors in accordance with the details in the plans and as directed. Place anchors across the matting at the ends approximately 1 ft. apart. Place anchors along the outer edges and down the center of the matting 3 ft. apart.

All bare side slope sections of the skimmer basin shall be seeded with a temporary or permanent seed mix as directed and in accordance with Articles 1620-3, 1620-4, 1620-5, 1660-4, 1660-5 and 1660-7 of the *Standard Specifications*. Straw or excelsior matting shall be installed on all bare side slope sections immediately upon the completion of seeding and in accordance with Article 1631-3 of the *Standard Specifications*.

Measurement and Payment

Silt Excavation will be measured and paid for in accordance with Article 1630-4 of the *Standard Specifications*, as calculated from the typical section throughout the length of the basin as shown on the final approved plans.

Geotextile for Soil Stabilization will be measured and paid for in accordance with Article 270-4 of the *Standard Specifications*.

Coir Fiber Baffles will be measured and paid for in accordance with Article 1640-4 of the *Standard Specifications*.

___" *Skimmer* will be measured in units of each. ___" *Skimmer* will be measured and paid for as the maximum number of each size skimmer acceptably installed and in use at any one time during the life of the project. Barrel and arm pipe, cleanout, relocation and reinstallation of ___" *Skimmer* is considered incidental to the measurement of the quantity of ___" *Skimmer* and no separate payment will be made. No separate payment shall be made if ___" *Skimmer*, barrel and/or arm pipe(s) are damaged by ice accumulation.

Coir Fiber Mat will be measured and paid for as the actual number of square yards measured along the surface of the ground over which coir fiber mat is installed and accepted.

Temporary Slope Drain will be measured and paid for in accordance with Article 1622-4 of the *Standard Specifications*.

Stone for Erosion Control, Class ___ will be measured and paid for in accordance with Article 1610-4 of the *Standard Specifications*.

Seeding and Mulching will be measured and paid for in accordance with Article 1660-8 of the *Standard Specifications*.

Seed for Temporary Seeding will be measured and paid for in accordance with Article 1620-6 of the *Standard Specifications*.

Fertilizer for Temporary Seeding will be measured and paid for in accordance with Article 1620-6 of the *Standard Specifications*.

Matting for Erosion Control will be measured and paid for in accordance with Article 1631-4 of the *Standard Specifications*.

No measurement will be made for other items or for over excavation or stockpiling.

Payment will be made under:

Pay Item

___" Skimmer
Coir Fiber Mat

Pay Unit

Each
Square Yard

TIERED SKIMMER BASIN WITH BAFFLES:

Description

Provide a tiered skimmer basin to remove sediment from construction site runoff at locations shown in the erosion control plans. See the Tiered Skimmer Basin Detail sheet provided in the erosion control plans. Tiered Skimmer Basins shall be installed in areas where topography creates a large elevation difference between the inlet and outlet of a single skimmer basin. Work includes constructing sediment basins, installation of coir fiber baffles, installation of temporary slope drain pipe, furnishing, installation and cleanout of skimmer, providing and placing stone pad on bottom of basin underneath skimmer device, providing and placing geotextile spillway liners, providing coir fiber mat stabilization for the skimmer outlet, disposing of excess materials, removing temporary slope drain pipe, coir fiber baffles, geotextile liner and skimmer device, backfilling basin area with suitable material and providing proper drainage when basin area is abandoned.

Materials

Item	Section
Stone for Erosion Control, Class B	1042
Geotextile for Soil Stabilization, Type 4	1056
Fertilizer for Temporary Seeding	1060-2
Seed for Temporary Seeding	1060-4
Seeding and Mulching	1060-4
Matting for Erosion Control	1060-8
Staples	1060-8
Coir Fiber Mat	1060-14
Temporary Slope Drain	1622-2
Coir Fiber Baffle	1640

Provide appropriately sized and approved skimmer device.

Provide Schedule 40 PVC pipe with a length of 6 ft. to attach to the skimmer and the coupling connection to serve as the arm pipe. For skimmer sizes of 2.5 in. and smaller, the arm pipe diameter shall be 1.5 inches. For skimmer sizes of 3 in. and larger, refer to manufacturer recommendation.

Provide 4" diameter Schedule 40 PVC pipe to attach to coupling connection of skimmer to serve as the barrel pipe through the earthen dam.

Anchors: Staples, stakes, or reinforcement bars shall be used as anchors.

Wooden Stakes:

Provide hardwood stakes 12"- 24" long with a 2" x 2" nominal square cross section. One end of the stake must be sharpened or beveled to facilitate driving through the coir fiber mat and down into the underlying soil. The other end of the stake needs to have a 1"- 2" long head at the top with a 1"- 2" notch following to catch and secure the coir fiber mat.

Steel Reinforcement Bars:

Provide uncoated #10 steel reinforcement bars 24" nominal length. The bars shall have a 4" diameter bend at one end with a 4" straight section at the tip to catch and secure the coir fiber mat.

Staples:

Provide staples made of 0.125" diameter new steel wire formed into a *u* shape not less than 12" in length with a throat of 1" in width.

Construction Methods

Excavate basins according to the erosion control plans with basin surface free of obstructions, debris, and pockets of low-density material. Install temporary slope drain pipe and construct the primary spillways according to the Tiered Skimmer Basin Detail sheet in the erosion control plans. Construct the coir fiber baffles according to *Roadway Standard Drawings* No. 1640.01 and Section 1640 of the *Standard Specifications*. Multiple upper basins, or Modified Silt Basins Type 'B' as labeled on the detail, may be required based on site conditions and as directed.

Install skimmer device according to manufacturer recommendations. Install 4" Schedule 40 PVC pipe into dam on the lower side of basin 1 ft. from the bottom of the basin and according to the detail, and extend the pipe so the basin will drain. Attach a 6 ft. arm pipe to the coupling connection and skimmer according to manufacturer recommendations. The coupling shall be rigid and non-buoyant and not exceed a diameter of 4" and 12" in length. Attach the rope included with the skimmer to the tee between the vent socket and the tube inlet, and the other end to a wooden stake or metal post. Clean out skimmer device when it becomes clogged with sediment and/or debris and is unable to float at the top of water in skimmer basin. Take appropriate measures to avoid ice accumulation in the skimmer device. Construct a stone pad of Class B stone directly underneath the skimmer device at bottom of basin. The pad shall be a minimum of 12" in height, and shall have a minimum cross sectional area of 4 ft. by 4 ft.

Line primary spillways with geotextile unrolled in the direction of flow and lay smoothly but loosely on soil surface without creases. Bury edges of geotextile in a trench at least 5" deep and tamp firmly. If geotextile for primary spillways is not one continuous piece of material, make horizontal overlaps a minimum of 18" with upstream geotextile overlapping the downstream geotextile. Secure geotextile with eleven gauge wire staples shaped into a *u* shape with a length of not less than 12" and a throat not less than 1" in width. Place staples along outer edges and throughout the geotextile a maximum of 3 ft. horizontally and vertically. Geotextile shall be placed to the bottom and across the entire width of the basin according to the Tiered Skimmer Basin with Baffles detail.

At the skimmer outlet, provide a smooth soil surface free from stones, clods, or debris that will prevent contact of the coir fiber matting with the soil. Unroll the matting and apply without stretching such that it will lie smoothly but loosely on the soil surface. Wooden stakes, reinforcement bars, or staples may be used as anchors in accordance with the details in the plans and as directed. Place anchors across the matting at the ends approximately 1 ft. apart. Place

anchors along the outer edges and down the center of the matting 3 ft. apart. Place sealant inside basin around barrel pipe on top of geotextile with a minimum width of 6 in.

All bare side slope sections of the skimmer basin shall be seeded with a temporary or permanent seed mix as directed and in accordance with Articles 1620-3, 1620-4, 1620-5, 1660-4, 1660-5 and 1660-7 of the *Standard Specifications*. Straw or excelsior matting shall be installed on all bare side slope sections immediately upon the completion of seeding and in accordance with Article 1631-3 of the *Standard Specifications*.

Measurement and Payment

Silt Excavation will be measured and paid for in accordance with Article 1630-4 of the *Standard Specifications*, as calculated from the typical section throughout the length of the basin as shown on the final approved plans.

Geotextile for Soil Stabilization will be measured and paid for in accordance with Article 270-4 of the *Standard Specifications*.

Coir Fiber Baffles will be measured and paid for in accordance with Article 1640-4 of the *Standard Specifications*.

___" *Skimmer* will be measured in units of each. ___" *Skimmer* will be measured and paid for as the maximum number of each size skimmer acceptably installed and in use at any one time during the life of the project. Barrel and arm pipe, cleanout, relocation and reinstallation of ___" *Skimmer* is considered incidental to the measurement of the quantity of ___" *Skimmer* and no separate payment will be made. No separate payment shall be made if ___" *Skimmer*, barrel and/or arm pipe(s) are damaged by ice accumulation.

Coir Fiber Mat will be measured and paid for as the actual number of square yards measured along the surface of the ground over which coir fiber mat is installed and accepted.

Temporary Slope Drain will be measured and paid for in accordance with Article 1622-4 of the *Standard Specifications*.

Stone for Erosion Control, Class ___ will be measured and paid for in accordance with Article 1610-4 of the *Standard Specifications*.

Seeding and Mulching will be measured and paid for in accordance with Article 1660-8 of the *Standard Specifications*.

Seed for Temporary Seeding will be measured and paid for in accordance with Article 1620-6 of the *Standard Specifications*.

Fertilizer for Temporary Seeding will be measured and paid for in accordance with Article 1620-6 of the *Standard Specifications*.

Matting for Erosion Control will be measured and paid for in accordance with Article 1631-4 of the *Standard Specifications*.

No measurement will be made for other items or for over excavation or stockpiling.

Payment will be made under:

Pay Item	Pay Unit
___" Skimmer	Each
Coir Fiber Mat	Square Yard

COIR FIBER WATTLES WITH POLYACRYLAMIDE (PAM):

Description

Coir Fiber Wattles are tubular products consisting of coir fibers (coconut fibers) encased in coir fiber netting. Coir Fiber Wattles are used on slopes or channels to intercept runoff and act as a velocity break. Coir Fiber Wattles are to be placed at locations shown on the plans or as directed. Installation shall follow the detail provided in the plans and as directed. Work includes furnishing materials, installation of coir fiber wattles, matting installation, PAM application, and removing wattles.

Materials

Coir Fiber Wattle shall meet the following specifications:

100% Coir (Coconut) Fibers	
Minimum Diameter	12 in.
Minimum Density	3.5 lb/ft ³ +/- 10%
Net Material	Coir Fiber
Net Openings	2 in. x 2 in.
Net Strength	90 lbs.
Minimum Weight	2.6 lbs./ft. +/- 10%

Anchors: Stakes shall be used as anchors.

Wooden Stakes:

Provide hardwood stakes a minimum of 2-ft. long with a 2 in. x 2 in. nominal square cross section. One end of the stake must be sharpened or beveled to facilitate driving down into the underlying soil.

Matting shall meet the requirements of Article 1060-8 of the *Standard Specifications*, or shall meet specifications provided elsewhere in this contract.

Provide staples made of 0.125" diameter new steel wire formed into a *u* shape not less than 12" in length with a throat of 1" in width.

Polyacrylamide (PAM) shall be applied in powder form and shall be anionic or neutrally charged. Soil samples shall be obtained in areas where the wattles will be placed, and from offsite material used to construct the roadway, and analyzed for the appropriate PAM flocculant to be utilized with each wattle. The PAM product used shall be listed on the North Carolina Department of Environmental Quality Division of Water Resources web site as an approved PAM product for use in North Carolina.

Construction Methods

Coir Fiber Wattles shall be secured to the soil by wire staples approximately every 1 linear foot and at the end of each section of wattle. A minimum of 4 stakes shall be installed on the downstream side of the wattle with a maximum spacing of 2 linear feet along the wattle, and according to the detail. Install a minimum of 2 stakes on the upstream side of the wattle according to the detail provided in the plans. Stakes shall be driven into the ground a minimum of 10 in. with no more than 2 in. projecting from the top of the wattle. Drive stakes at an angle according to the detail provided in the plans.

Only install coir fiber wattle(s) to a height in ditch so flow will not wash around wattle and scour ditch slopes and according to the detail provided in the plans and as directed. Overlap adjoining sections of wattles a minimum of 6 in.

Installation of matting shall be in accordance with the detail provided in the plans, and in accordance with Article 1631-3 of the *Standard Specifications*, or in accordance with specifications provided elsewhere in this contract.

Apply PAM over the lower center portion of the coir fiber wattle where the water is going to flow over at a rate of 2 ounces per wattle, and 1 ounce of PAM on matting on each side of the wattle. PAM applications shall be done during construction activities after every rainfall event that is equal to or exceeds 0.50 in.

The Contractor shall maintain the coir fiber wattles until the project is accepted or until the wattles are removed, and shall remove and dispose of silt accumulations at the wattles when so directed in accordance with the requirements of Section 1630 of the *Standard Specifications*.

Measurement and Payment

Coir Fiber Wattles will be measured and paid for by the actual number of linear feet of wattles which are installed and accepted. Such price and payment will be full compensation for all work covered by this section, including, but not limited to, furnishing all materials, labor, equipment and incidentals necessary to install the *Coir Fiber Wattles*.

Matting will be measured and paid for in accordance with Article 1631-4 of the *Standard Specifications*, or in accordance with specifications provided elsewhere in this contract.

Polyacrylamide(PAM) will be measured and paid for by the actual weight in pounds of PAM applied to the coir fiber wattles. Such price and payment will be full compensation for all work covered by this section, including, but not limited to, furnishing all materials, labor, equipment and incidentals necessary to apply the *Polyacrylamide(PAM)*.

Payment will be made under:

Pay Item	Pay Unit
Polyacrylamide(PAM)	Pound
Coir Fiber Wattle	Linear Foot

TEMPORARY ROCK SILT CHECK TYPE A WITH EXCELSIOR MATTING AND POLYACRYLAMIDE (PAM):

Description

Temporary Rock Silt Checks Type A with Excelsior Matting and Polyacrylamide (PAM) are devices utilized in temporary and permanent ditches to reduce runoff velocity and incorporate PAM into the construction runoff to increase settling of sediment particles and reduce turbidity of runoff. Temporary Rock Silt Checks Type A with Excelsior Matting and PAM are to be placed at locations shown on the plans or as directed. Installation shall follow the detail provided in the plans and as directed. Work includes furnishing materials, installation of Temporary Rock Silt Checks Type A, matting installation, PAM application, and removing Temporary Rock Silt Checks Type A with Excelsior Matting and PAM.

Materials

Structural stone shall be class B stone that meets the requirements of Section 1042 of the *Standard Specifications* for Stone for Erosion Control, Class B.

Sediment control stone shall be #5 or #57 stone, which meets the requirements of Section 1005 of the *Standard Specifications* for these stone sizes.

Matting shall meet the requirements of Excelsior Matting in Subarticle 1060-8(B) of the *Standard Specifications*, or shall meet specifications provided elsewhere in this contract.

Polyacrylamide (PAM) shall be applied in powder form and shall be anionic or neutrally charged. Soil samples shall be obtained in areas where the Temporary Rock Silt Checks Type A with Excelsior Matting and PAM will be placed, and from offsite material used to construct the roadway, and analyzed for the appropriate PAM flocculant to be utilized with each Temporary Rock Silt Check Type A. The PAM product used shall be listed on the North Carolina Department of Environmental Quality Division of Water Resources web site as an approved PAM product for use in North Carolina.

Construction Methods

Temporary Rock Silt Checks Type A shall be installed in accordance with Subarticle 1633-3(A) of the *Standard Specifications*, Roadway Standard Drawing No. 1633.01 and the detail provided in the plans.

Installation of matting shall be in accordance with the detail provided in the plans, and anchored by placing Class B stone on top of the matting at the upper and lower ends.

Apply PAM at a rate of 4 ounces over the center portion of the Temporary Rock Silt Checks Type A and matting where the water is going to flow over. PAM applications shall be done during construction activities and after every rainfall event that is equal to or exceeds 0.50 in.

The Contractor shall maintain the Temporary Rock Silt Checks Type A with Excelsior Matting and PAM until the project is accepted or until the Temporary Rock Silt Checks Type A with Excelsior Matting and PAM are removed, and shall remove and dispose of silt accumulations at the Temporary Rock Silt Checks Type A with Excelsior Matting and PAM when so directed in accordance with the requirements of Section 1630 of the *Standard Specifications*.

Measurement and Payment

Temporary Rock Silt Checks Type A will be measured and paid for in accordance with Article 1633-5 of the *Standard Specifications*, or in accordance with specifications provided elsewhere in this contract.

Matting will be measured and paid for in accordance with Article 1631-4 of the *Standard Specifications*, or in accordance with specifications provided elsewhere in this contract.

Polyacrylamide(PAM) will be measured and paid for by the actual weight in pounds of PAM applied to the Temporary Rock Silt Checks Type A. Such price and payment will be full compensation for all work covered by this section, including, but not limited to, furnishing all materials, labor, equipment and incidentals necessary to apply the *Polyacrylamide(PAM)*.

Payment will be made under:

Pay Item	Pay Unit
Polyacrylamide(PAM)	Pound

COIR FIBER MAT:

Description

Furnish material, install and maintain coir fiber mat in locations shown on the plans or in locations as directed. Work includes providing all materials, excavating and backfilling, and placing and securing coir fiber mat with stakes, steel reinforcement bars or staples as directed.

Materials

Item	Section
Coir Fiber Mat	1060-14

Anchors: Stakes, reinforcement bars, or staples shall be used as anchors.

Wooden Stakes:

Provide hardwood stakes 12" - 24" long with a 2" x 2" nominal square cross section. One end of the stake must be sharpened or beveled to facilitate driving through the coir fiber mat and down into the underlying soil. The other end of the stake needs to have a 1" - 2" long head at the top with a 1" - 2" notch following to catch and secure the coir fiber mat.

Steel Reinforcement Bars:

Provide uncoated #10 steel reinforcement bars 24" nominal length. The bars shall have a 4" diameter bend at one end with a 4" straight section at the tip to catch and secure the coir fiber mat.

Staples:

Provide staples made of 0.125" diameter new steel wire formed into a *u* shape not less than 12" in length with a throat of 1" in width.

Construction Methods

Place the coir fiber mat immediately upon final grading. Provide a smooth soil surface free from stones, clods, or debris that will prevent the contact of the mat with the soil. Unroll the mat and apply without stretching such that it will lie smoothly but loosely on the soil surface.

For stream relocation applications, take care to preserve the required line, grade, and cross section of the area covered. Bury the top slope end of each piece of mat in a narrow trench at least 6 in. deep and tamp firmly. Where one roll of matting ends and a second roll begins, overlap the end of the upper roll over the buried end of the second roll so there is a 6 in. overlap. Construct check trenches at least 12 in. deep every 50 ft. longitudinally along the edges of the mat or as directed. Fold over and bury mat to the full depth of the trench, close and tamp firmly. Overlap mat at least 6 in. where 2 or more widths of mat are installed side by side.

Place anchors across the mat at the ends approximately 1 ft. apart. Place anchors along the outer edges and down the center of the mat 3 ft. apart.

Adjustments in the trenching or anchoring requirements to fit individual site conditions may be required.

Measurement and Payment

Coir Fiber Mat will be measured and paid for as the actual number of square yards measured along the surface of the ground over which coir fiber mat is installed and accepted.

No measurement will be made for anchor items.

Payment will be made under:

Pay Item	Pay Unit
Coir Fiber Mat	Square Yard

CONCRETE WASHOUT STRUCTURE:

(12-10-20)

Description

Concrete washout structures are enclosures above or below grade to contain concrete waste water and associated concrete mix from washing out ready-mix trucks, drums, pumps, or other equipment. Concrete washouts must collect and retain all the concrete washout water and solids, so that this material does not migrate to surface waters or into the ground water. These enclosures are not intended for concrete waste not associated with wash out operations.

The concrete washout structure may include constructed devices above or below ground and or commercially available devices designed specifically to capture concrete wash water.

Materials

Item	Section
Temporary Silt Fence	1605

Safety Fence shall meet the specifications as provided elsewhere in this contract.

Geomembrane basin liner shall meet the following minimum physical properties for low permeability; it shall consist of a polypropylene or polyethylene 10 mil think geomembrane. If the minimum setback dimensions can be achieved the liner is not required. (5 feet above groundwater, 50 feet from top of bank of perennial stream, other surface water body, or wetland.)

Construction Methods

Build an enclosed earthen berm or excavate to form an enclosure in accordance with the details and as directed.

Install temporary silt fence around the perimeter of the enclosure in accordance with the details and as directed if structure is not located in an area where existing erosion and sedimentation control devices are capable to containing any loss of sediment.

Post a sign with the words “Concrete Washout” in close proximity of the concrete washout area, so it is clearly visible to site personnel. Install safety fence as directed for visibility to construction traffic.

The construction details for the above grade and below grade concrete washout structures can be found on the following web page link:

<https://connect.ncdot.gov/resources/roadside/SoilWaterDocuments/ConcreteWashoutStructuredetail.pdf>

[Alternate details for accommodating concrete washout may be submitted for review and approval.](#)

[The alternate details shall include the method used to retain and dispose of the concrete waste water within the project limits and in accordance with the minimum setback requirements.](#) (5 feet above groundwater, 50 feet from top of bank of perennial stream, other surface water body, or wetland.)

Maintenance and Removal

Maintain the concrete washout structure(s) to provide adequate holding capacity plus a minimum freeboard of 12 inches. Remove and dispose of hardened concrete and return the structure to a functional condition after reaching 75% capacity.

Inspect concrete washout structures for damage and maintain for effectiveness.

Remove the concrete washout structures and sign upon project completion. Grade the earth material to match the existing contours and permanently seed and mulch area.

Measurement and Payment

Concrete Washout Structure will be paid for per each enclosure installed in accordance with the details. If alternate details or commercially available devices are approved, then those devices will also be paid for per each approved and installed device.

Temporary Silt Fence will be measured and paid for in accordance with Article 1605-5 of the *Standard Specifications*.

Safety Fence shall be measured and paid for as provided elsewhere in this contract.

No measurement will be made for other items or for over excavation or stockpiling.

Payment will be made under:

Pay Item

Concrete Washout Structure

Pay Unit

Each

LITTER REMOVAL (MOWING AREAS ONLY):

(07-19-22)

Description

This work consists of the pickup, removal, and disposal of litter from roadsides within the construction project prior to mowing operations.

Construction Methods

Provide labor, equipment and materials necessary for the pickup and removal of litter from non-construction sources and the disposal of same into state approved landfills. The Contractor shall abide by all ordinances, laws and regulations regarding disposal of litter and recycling of eligible materials. Wastes generated from construction activities shall be managed as provided elsewhere in the contract. Litter items may consist of any item not considered normal to the right-of-way, including but not limited to, varied sizes of bottles, cans, paper, tires, tire pieces, lumber, vehicle parts, building supplies, metals, household furnishings, cardboard, plastics, ladders, brush and other items not considered normal to the right of way. Litter removal shall be performed in designated areas within five days prior to any mowing operations and as directed by the Engineer. Designated areas shall include vegetated medians and shoulders within the project limits including all interchange ramps and other areas to be mown. Designated areas may be omitted for litter removal by the Engineer due to safety concerns.

The Contractor shall provide adequate personnel and materials to collect and remove litter. The Contractor shall be responsible for locating and utilizing approved local landfills and recycling facilities. Refer to Section 105-27 of the *Standard Specifications* for potential hazardous materials. All collected litter shall be containerized immediately and kept off the traveled portions of the roadway, shoulders, and rights-of-way (including paved shoulders). All collected litter that is small enough to be placed in a bag shall be bagged immediately. All collected litter that is too large for a bag shall be placed into a vehicle. Extended storage or stockpiling of collected litter and recyclables will not be permitted.

The Contractor's personnel shall dispose of any litter in a landfill approved by North Carolina Division of Waste Management. The Contractor will not be allowed to use NCDOT accounts at the landfills/recycling centers nor be allowed to dispose of the litter in NCDOT trash containers on any NCDOT property.

The Contractor shall report online the number of bags of litter and any recycling on the NCDOT Litter Management Website on the date of the pickup at the following website:

<https://apps.ncdot.gov/LM>

An access code ('Pickup Key') for the online reporting portal may be obtained via emailing the Roadside Environmental Unit Litter Management Section at ncdot.clr@ncdot.gov. The Contractor shall request access to the litter removal reporting website prior to starting initial litter collection operations.

Measurement and Payment

The quantity of litter removal to be performed will be affected by the actual conditions that occur during construction of the project. The quantity of litter removal may be increased, decreased, or eliminated entirely as directed by the Engineer. Such variations in quantity will not be considered as alterations in the details of construction or a change in the character of the work.

Manual Litter Removal will be measured and paid as the actual number of man hours each worker spends picking up litter. Such price and payment will be full compensation for all litter removal work covered by *Litter Removal*, including, but not limited to, furnishing all materials, labor, equipment, transport, reporting, and incidentals necessary to accomplish the work.

Litter Disposal will be measured and paid for by the actual number of tons of litter collected and properly disposed of at a state approved landfill. Such price and payment will be full compensation for all fees, labor, transport, and incidentals necessary to dispose of collected litter associated with *Litter Removal*.

All traffic control necessary to provide a safe work area for *Litter Removal* shall be paid for as specified elsewhere in the contract.

Payment will be made under:

Pay Item	Pay Unit
Manual Litter Removal	MHR
Litter Disposal	TON

FABRIC INSERT INLET PROTECTION DEVICE (HIGH FLOW)

(6-29-17)

Description

This work shall consist of installing, maintaining, and removing *Fabric Insert Inlet Protection Device*, of the type specified, in inlet structures (catch basins, drop inlets, etc) in areas where asphalt or concrete may prevent the proper installation of a Rock Inlet Sediment Traps Type C, or as directed.

Materials

The product shall be a fabric inlet protection device composed of a fitted woven polypropylene geotextile double sewn with nylon thread suspended sack. The *Fabric Insert Inlet Protection Device* shall be manufactured to fit the opening of the catch basin or drop inlet or shall have a

deflector to direct runoff from the curb opening into the fabric sack. The *Fabric Insert Inlet Protection Device* shall have a rigid frame or support system to support the loaded weight of the product. The product shall have lifting loops for removing the device from the basin and will have dump straps attached at the bottom to facilitate the emptying of the device. The *Fabric Insert Inlet Protection Device* shall have an overflow system to allow stormwater to enter the inlet structure and avoid ponding on the roadway when the device reaches capacity

The stitching shall meet the following physical properties:

Physical	Test Method	English
Average Wide Width Strength	ASTM D-4884	165 lb/in

The fitted filter assembly shall have the following physical properties:

Physical	Test Method	English
Grab Tensile	ASTM D-4632	255 x 275 lbs
Minimum Puncture Strength	ASTM D-4833	125 lbs
Mullen Burst	ASTM D-3786	420 PSI
Minimum UV Resistance	ASTM D-4355	70 %.
Flow Rate	ASTM D-4491	200 gal/min/ft ²
Apparent Opening	ASTM D-4751	20 US Sieve
Permittivity	ASTM D-4491	1.5 sec ⁻¹

Construction Methods

Strictly comply with manufacturer’s installation instructions and recommendations. Maintenance shall include regular daily inspections and after each qualifying rain event. The *Fabric Insert Inlet Protection Device* shall be emptied, cleaned and placed back into the basin when it reaches 50% capacity or as directed.

Measurement and Payment

This work will be paid for at the contract unit price per *Fabric Insert Inlet Protection Device* of the type specified, complete in place and accepted. Such payment shall be full compensation for furnishing and installing the *Fabric Insert Inlet Protection Device* in accordance with this specification and for all required maintenance.

Maintenance of the device, cleanout and disposal of accumulated sediments shall be paid for by *Fabric Insert Inlet Protection Device Cleanout*.

Payment will be made under:

Pay Item	Pay Unit
Fabric Insert Inlet Protection Device	Each
Fabric Insert Inlet Protection Device Cleanout	Each

TACK FOR MULCH FOR EROSION CONTROL:

(07-19-22)

Description

This work consists of supplying and installing of an approved material for binding mulch for erosion control in accordance with Section 1060-5, Section 1615 and Section 1660 of the *Standard Specifications*. This provision defines acceptable materials and rates for tacking material for holding mulch in place.

Materials

(a) Emulsified Asphalt

Asphalt emulsion tack shall conform to the requirements of AASHTO M 140, Specification for Emulsified Asphalt. The emulsified asphalt may be rapid setting, medium setting, or slow setting. Apply emulsified asphalt tackifier at a rate of 0.10 gallons per square yard (approximately 484 gallons per acre).

(b) Cellulose Hydromulch

Cellulose hydromulch products shall be non-toxic, weed-free, prepackaged cellulose fiber (pulp) material containing no more than 3% ash or other inert materials. Cellulose hydromulches may contain dyes or binders specifically formulated to enhance the adhesive qualities of the hydromulch. Apply cellulose hydromulches at a rate of 1000 pounds (dry weight) per acre.

Wood fiber or wood fiber blend hydromulches may be substituted for cellulose hydromulch at the same application rate.

(c) Other tackifiers

Other approved materials, specifically designed and manufactured for application as a straw mulch tacking agent, may be used at the manufacturer's recommended rate.

Construction Methods

Apply the Tack for Mulch for Erosion Control uniformly across straw mulch per Section 1615 and Section 1660 of the *Standard Specifications*.

Payment

Tack for Mulch for Erosion Control is incidental to the application of *Temporary Mulching*, Section 1615-4, and *Seeding and Mulching*, Section 1660-8, and no additional payment will be made.

Signals and Intelligent Transportation Systems
Project Special Provisions
(Version 18.7)

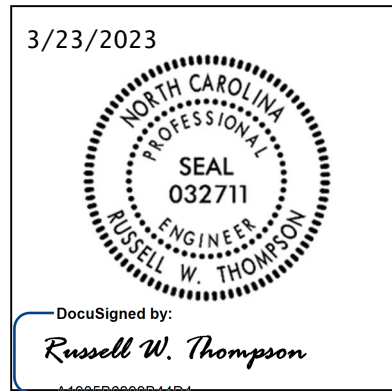

Prepared By: RWT
23-Mar-23

Document not considered final
unless all signatures completed.

Contents

1. 2018 STANDARD SPECIFICATIONS FOR ROADS & STRUCTURES.....4
1.1. GENERAL REQUIREMENTS – MATERIALS (1098-1(H))4
1.2. GENERAL REQUIREMENTS – CONSTRUCTION METHODS (1700-3(K))4
1.3. GENERAL REQUIREMENTS – CONSTRUCTION METHODS (1700-3(L)).....5
1.4. GENERAL REQUIREMENTS – CONSTRUCTION METHODS (1700-3(M)).....5
1.5. WOOD POLES – CONSTRUCTION METHODS (1720-3)5
2. SIGNAL HEADS.....5
2.1. MATERIALS5
A. General:5
B. Vehicle Signal Heads:.....7
C. Pedestrian Signal Heads:9
D. Signal Cable:.....10
3. CONTROLLERS WITH CABINETS11
3.1. MATERIALS – TYPE 2070E CONTROLLERS11
3.2. MATERIALS – GENERAL CABINETS11
3.3. MATERIALS – TYPE 170E CABINETS12
A. Type 170 E Cabinets General:12
B. Type 170 E Cabinet Electrical Requirements:12
C. Type 170 E Cabinet Physical Requirements:.....19
D. Model 2018 Enhanced Conflict Monitor:22
3.4. MATERIALS – TYPE 170 DETECTOR SENSOR UNITS32
4. VIDEO IMAGING LOOP EMULATOR DETECTOR SYSTEMS32
4.1. DESCRIPTION32
4.2. MATERIALS33
A. General:33
B. Loop Emulator System:34
C. Video Imaging Loop Emulator System Support:.....35
4.3. CONSTRUCTION METHODS35
4.4. MEASUREMENT AND PAYMENT36
5. METAL POLE SUPPORTS37
5.1. METAL POLES37
A. General:37
B. Materials:38
C. Design:.....40
D. Strain Poles:.....42
5.2. DRILLED PIER FOUNDATIONS FOR METAL POLES.....43

U-2729**TS-2****Forsyth County**

A.	Description:	43
B.	Soil Test and Foundation Determination:	44
C.	Drilled Pier Construction:	46
5.3.	POLE NUMBERING SYSTEM	46
5.4.	MEASUREMENT AND PAYMENT	46
6.	BACK PULL FIBER OPTIC CABLE	47
6.1.	DESCRIPTION	47
6.2.	CONSTRUCTION	47
6.3.	MEASUREMENT AND PAYMENT	47
7.	ETHERNET EDGE SWITCH.....	47
7.1.	DESCRIPTION	47
A.	Ethernet Edge Switch:	47
B.	Network Management:	48
7.2.	MATERIALS	48
A.	General:	48
B.	Compatibility Acceptance.....	48
C.	Standards:	48
D.	Functional:	49
E.	Physical Features:	49
F.	Management Capabilities:	50
G.	Electrical Specifications:	51
H.	Environmental Specifications:.....	51
I.	Ethernet Patch Cable:	52
7.3.	CONSTRUCTION METHODS	52
A.	General:	52
B.	Edge Switch:.....	52
7.4.	MEASUREMENT AND PAYMENT	52
8.	DIGITAL CCTV CAMERA ASSEMBLY	53
8.1.	DESCRIPTION.....	53
8.2.	MATERIALS	53
A.	General.....	53
B.	Camera and Lens	53
C.	Camera Housing	55
D.	Pan and Tilt Unit.....	55
E.	Video Ethernet Encoder.....	55
F.	Control Receiver/Driver	55
G.	Electrical.....	56
H.	CCTV Camera Attachment to Pole.....	56
I.	Riser.....	56
J.	Data line Surge Suppression.....	56
K.	POE Injector	57
8.3.	CONSTRUCTION METHODS	57
A.	General.....	57
B.	Electrical and Mechanical Requirements.....	58
C.	General Test Procedure.....	58
D.	Compatibility Tests.....	59
E.	Operational Field Test (On-Site Commissioning)	59
F.	Local Field Testing	59
G.	Central Operations Testing	60
8.4.	MEASUREMENT AND PAYMENT.....	60
9.	CCTV FIELD EQUIPMENT CABINET.....	61
9.1.	DESCRIPTION.....	61
9.2.	MATERIALS	61

A.	CCTV Cabinet	61
B.	Shelf Drawer.....	61
C.	Cabinet Light	61
D.	Surge Protection for System Equipment.....	62
9.3.	CONSTRUCTION METHODS	63
A.	General.....	63
9.4.	MEASUREMENT AND PAYMENT.....	63
10.	CCTV WOOD POLE	63
10.1.	DESCRIPTION.....	63
10.2.	MATERIALS	64
10.3.	CCTV WOOD POLE.....	64
10.4.	CONSTRUCTION METHODS	64
10.5.	MEASUREMENT AND PAYMENT.....	64
11.	AIR TERMINAL & LIGHTNING PROTECTION SYSTEM.....	64
11.1.	DESCRIPTION.....	64
11.2.	MATERIALS	64
A.	General.....	64
B.	Wood Pole	65
C.	Metal Pole.....	65
D.	Copper Lightning Conductor and Ground Rods	65
11.3.	CONSTRUCTION METHODS	65
A.	Wood Pole	65
B.	Metal Pole.....	66
C.	Copper Lightning Conductor and Ground Rods	66
11.4.	MEASUREMENT AND PAYMENT.....	66
12.	ELECTRICAL SERVICE FOR ITS DEVICES	66
12.1.	DESCRIPTION	66
12.2.	MATERIAL	67
A.	Meter Base/Disconnect Combination Panel	67
B.	3-Wire Copper Service Entrance Conductors.....	68
C.	3-Wire Copper Feeder Conductors	68
D.	Grounding System	68
12.3.	CONSTRUCTION METHODS	68
A.	General.....	68
B.	Meter Base/Disconnect Combination Panel	68
C.	3-Wire Copper Service Entrance Conductors.....	69
D.	3-Wire Copper Feeder Conductors	69
E.	Grounding System	69
12.4.	MEASUREMENT AND PAYMENT	69
13.	OBSERVATION PERIOD FOR ITS DEVICES	70
13.1.	30-DAY OBSERVATION PERIOD.....	70
13.2.	FINAL ACCEPTANCE.....	71
13.3.	MEASUREMENT AND PAYMENT.....	71

1. 2018 STANDARD SPECIFICATIONS FOR ROADS & STRUCTURES

The 2018 Standard Specifications are revised as follows:

1.1. GENERAL REQUIREMENTS – Materials (1098-1(H))

Page 10-212, line 12, revise title of section 1098-1(H) from “Electrical Service” to “Electrical Service for Traffic Signals”.

Page 10-212, revise paragraph beginning on line 13 to read “Furnish external electrical service disconnects with a single pole 50 ampere inverse time circuit breaker with at least 10,000 RMS symmetrical amperes short circuit current rating in a lockable NEMA 3R enclosure. For electrical service to an Advanced Transportation Controller (ATC) cabinet, provide a single pole 30 ampere inverse time circuit breaker with at least 10,000 RMS symmetrical amperes short circuit current rating. Ensure service disconnects are listed as meeting UL Standard UL-489 and marked as being suitable for use as service equipment. Fabricate enclosure from galvanized steel and electrostatically apply dry powder paint finish, light gray in color, to yield a minimum thickness of 2.4 mils. Provide ground bus and neutral bus with at least 5 terminals with minimum wire capacity range of number 14 through number 4. Ensure each service has only one disconnecting means in the enclosure. Place barriers in service equipment such that no uninsulated, ungrounded service busbar, or service terminal is exposed.”

1.2. GENERAL REQUIREMENTS – Construction Methods (1700-3(K))

Page 17-4, revise paragraph starting on line 10 to read:

“Where electrical services do not include an external electrical service disconnect, modify service to include electrical service disconnect and a new grounding electrode system.

Provide a grounding electrode system at all new electrical services. All grounding and bonding equipment shall conform to UL Standard 467. Permanently bond grounding conductor to ground rod using an irreversible ground connector. Unless the irreversible ground connectors are designed for use with more than one conductor, only one conductor shall be used with each irreversible ground connector. Ensure all irreversible ground connectors are installed per manufacturer’s installation instructions. Irreversible compression ground connectors requiring the use of a die for installation shall be made using a hydraulic, power, or ratcheting type crimper with appropriate dies. The use of handheld pliers for crimping irreversible compression ground connectors is prohibited.

Modify existing electrical services, as necessary, to meet the grounding requirements of the NEC, these Standard Specifications and the project plans. Remove any ground rods in the cabinet foundation and install a new grounding electrode system. Cut off abandoned ground rods in the cabinet foundation flush with the foundation surface.

In addition to NEC requirements, test grounding electrode resistance for a maximum of 20 ohms. Furnish and install additional ground rods to grounding electrode system as necessary to meet the Standard Specifications, Standard Drawings, and test requirements. Grounding electrode resistance test shall be verified or witnessed by the Engineer or the Engineer’s designated representative.

Follow test equipment’s procedures for measuring grounding electrode resistance. When using clamp-type ground resistance meters, readings of less than one ohm typically indicate a ground loop. Rework bonding and grounding circuits as necessary to remove ground loop circuits and retest. If a ground loop cannot be identified and removed to allow the proper use of a clamp-type ground resistance meter, use the three-point test method.

Submit a completed Inductive Loop & Grounding Test Form available on the Department's website.

For ease of inspection, the top of ground rods shall be 12 inches (\pm 1 inch) below finished grade and shall remain exposed until electrical inspection is complete. Provide a length of marker tape 6 inches below finished grade directly over grounding electrodes and conductors.

For ground rods installed in areas where the slope is greater than 4:1, the top of the ground rods shall be a minimum of 24" below finished grade. Provide a length of marker tape 6 inches to 12 inches below finished grade directly over grounding electrodes and conductors."

1.3. GENERAL REQUIREMENTS – Construction Methods (1700-3(L))

Page 17-4, revise paragraph starting on line 35 to read "Using an approved termination means, connect a #14 AWG minimum, 19-strand copper conductor (Type THWN) with insulation that is green or green with one or more yellow stripes to serve as an equipment grounding conductor to metal poles, vehicular and pedestrian signal pedestals, and other metallic components which are not otherwise bonded through means approved by the Engineer. For traffic signal installations, equipment grounding conductors shall have insulation that is green with one or more yellow stripes."

1.4. GENERAL REQUIREMENTS – Construction Methods (1700-3(M))

Page 17-4, Replace the sentence beginning on line 41 with "Prior to placing signal in the steady (stop-and-go) mode, the signal should be placed in the flashing mode for up to 7 days or as directed by the Engineer. The signal should not be placed in the steady (stop-and-go) mode on a Saturday or Sunday without prior approval from the Engineer. Do not place the signal in steady (stop-and-go) mode until inspected and without the prior approval of the Engineer."

1.5. WOOD POLES – Construction Methods (1720-3)

Page 17-18, revise sentence starting on line 13 to read "On new Department-owned poles, install a grounding system consisting of #6 AWG solid bare copper wire that is connected with an **irreversible ground connector** to a single ground rod installed at base of pole or to the electrical service grounding electrode system located within 10 feet of the pole."

2. SIGNAL HEADS

2.1. MATERIALS

A. General:

Fabricate vehicle signal head housings and end caps from die-cast aluminum. Fabricate 16-inch pedestrian signal head housings and end caps from die-cast aluminum. Provide visor mounting screws, door latches, and hinge pins fabricated from stainless steel. Provide interior screws, fasteners, and metal parts fabricated from stainless steel.

Fabricate tunnel and traditional visors from sheet aluminum.

Paint all surfaces inside and outside of signal housings and doors. Paint outside surfaces of tunnel and traditional visors, wire outlet bodies, wire entrance fitting brackets and end caps when supplied as components of messenger cable mounting assemblies, pole and pedestal mounting assemblies, and pedestrian pushbutton housings. Have electrostatically-applied, fused-polyester paint in highway yellow (Federal Standard 595C, Color Chip Number 13538) a minimum of 2.5 to 3.5 mils thick. Do not apply paint to the latching hardware, rigid vehicle signal head mounting brackets for mast-arm attachments, messenger cable hanger components or balance adjuster components.

U-2729

TS-6

Forsyth County

Have the interior surfaces of tunnel and traditional visors painted an alkyd urea black synthetic baking enamel with a minimum gloss reflectance and meeting the requirements of MIL-E-10169, "Enamel Heat Resisting, Instrument Black."

Where required, provide polycarbonate signal heads and visors that comply with the provisions pertaining to the aluminum signal heads listed on the QPL with the following exceptions:

Fabricate signal head housings, end caps, and visors from virgin polycarbonate material. Provide UV stabilized polycarbonate plastic with a minimum thickness of 0.1 ± 0.01 inches that is highway yellow (Federal Standard 595C, Color Chip 13538). Ensure the color is incorporated into the plastic material before molding the signal head housings and end caps. Ensure the plastic formulation provides the following physical properties in the assembly (tests may be performed on separately molded specimens):

Test	Required	Method
Specific Gravity	1.17 minimum	ASTM D 792
Flammability	Self-extinguishing	ASTM D 635
Tensile Strength, yield, PSI	8500 minimum	ASTM D 638
Izod impact strength, ft-lb/in [notched, 1/8 inch]	12 minimum	ASTM D 256

For pole mounting, provide side of pole mounting assemblies with framework and all other hardware necessary to make complete, watertight connections of the signal heads to the poles and pedestals. Fabricate the mounting assemblies and frames from aluminum with all necessary hardware, screws, washers, etc. to be stainless steel. Provide mounting fittings that match the positive locking device on the signal head with the serrations integrally cast into the brackets. Provide upper and lower pole plates that have a 1 ¼-inch vertical conduit entrance hubs with the hubs capped on the lower plate and 1 ½-inch horizontal hubs. Ensure that the assemblies provide rigid attachments to poles and pedestals so as to allow no twisting or swaying of the signal heads. Ensure that all raceways are free of sharp edges and protrusions, and can accommodate a minimum of ten Number 14 AWG conductors.

For pedestal mounting, provide a post-top slipfitter mounting assembly that matches the positive locking device on the signal head with serrations integrally cast into the slipfitter. Provide stainless steel hardware, screws, washers, etc. Provide a minimum of six 3/8 X 3/4-inch long square head bolts for attachment to pedestal. Provide a center post for multi-way slipfitters.

For light emitting diode (LED) traffic signal modules, provide the following requirements for inclusion on the Department's Qualified Products List for traffic signal equipment.

1. Sample submittal,
2. Third-party independent laboratory testing results for each submitted module with evidence of testing and conformance with all of the Design Qualification Testing specified in section 6.4 of each of the following Institute of Transportation Engineers (ITE) specifications:
 - Vehicle Traffic Control Signal Heads – Light Emitting Diode (LED) Circular Signal Supplement
 - Vehicle Traffic Control Signal Heads – Light Emitting Diode (LED) Vehicle Arrow Traffic Signal Supplement
 - Pedestrian Traffic Control Signal Indications –Light Emitting Diode (LED) Signal Modules.

(Note: The Department currently recognizes two approved independent testing laboratories. They are Intertek ETL Semko and Light Metrics, Incorporated with Garwood Laboratories. Independent laboratory tests from other laboratories may be considered as part of the QPL submittal at the discretion of the Department,

3. Evidence of conformance with the requirements of these specifications,
4. A manufacturer's warranty statement in accordance with the required warranty, and
5. Submittal of manufacturer's design and production documentation for the model, including but not limited to, electrical schematics, electronic component values, proprietary part numbers, bill of materials, and production electrical and photometric test parameters.
6. Evidence of approval of the product to bear the Intertek ETL Verified product label for LED traffic signal modules.

Ensure LED traffic signal modules meet the performance requirements for the minimum period of 15 years, provide a written warranty against defects in materials and workmanship for the modules for a period of 15 years after installation of the modules. During the warranty period, the manufacturer must provide new replacement modules within 45 days of receipt of modules that have failed at no cost to the State. Repaired or refurbished modules may not be used to fulfill the manufacturer's warranty obligations. Provide manufacturer's warranty documentation to the Department during evaluation of product for inclusion on Qualified Products List (QPL).

B. Vehicle Signal Heads:

Comply with the ITE standard "Vehicle Traffic Control Signal Heads". Provide housings with provisions for attaching backplates.

Provide visors that are 10 inches in length for 12-inch vehicle signal heads.

Provide a termination block with one empty terminal for field wiring for each indication plus one empty terminal for the neutral conductor. Have all signal sections wired to the termination block. Provide barriers between the terminals that have terminal screws with a minimum Number 8 thread size and that will accommodate and secure spade lugs sized for a Number 10 terminal screw.

Mount termination blocks in the yellow signal head sections on all in-line vehicle signal heads. Mount the termination block in the red section on five-section vehicle signal heads.

Furnish vehicle signal head interconnecting brackets. Provide one-piece aluminum brackets less than 4.5 inches in height and with no threaded pipe connections. Provide hand holes on the bottom of the brackets to aid in installing wires to the signal heads. Lower brackets that carry no wires and are used only for connecting the bottom signal sections together may be flat in construction.

For messenger cable mounting, provide messenger cable hangers, wire outlet bodies, balance adjusters, bottom caps, wire entrance fitting brackets, and all other hardware necessary to make complete, watertight connections of the vehicle signal heads to the messenger cable. Fabricate messenger cable hanger components, wire outlet bodies and balance adjuster components from stainless steel or malleable iron galvanized in accordance with ASTM A153 (Class A) or ASTM A123. Provide serrated rings made of aluminum. Provide messenger cable hangers with U-bolt clamps. Fabricate washers, screws, hex-head bolts and associated nuts, clevis pins, cotter pins, U-bolt clamps and nuts from stainless steel.

Provide LED vehicular traffic signal modules (hereafter referred to as modules) that consist of an assembly that uses LEDs as the light source in lieu of an incandescent lamp for use in traffic signal sections. Use LEDs that are aluminum indium gallium phosphorus (AlInGaP) technology for red and yellow indications and indium gallium nitride (InGaN) for green indications. Install the ultra bright

U-2729

TS-8

Forsyth County

type LEDs that are rated for 100,000 hours of continuous operation from -40°F to +165°F. Design modules to have a minimum useful life of 15 years and to meet all parameters of this specification during this period of useful life.

For the modules, provide spade terminals crimped to the lead wires and sized for a #10 screw connection to the existing terminal block in a standard signal head. Do not provide other types of crimped terminals with a spade adapter.

Ensure the power supply is integral to the module assembly. On the back of the module, permanently mark the date of manufacture (month & year) or some other method of identifying date of manufacture.

Tint the red, yellow and green lenses to correspond with the wavelength (chromaticity) of the LED. Transparent tinting films are unacceptable. Provide a lens that is integral to the unit with a smooth outer surface.

1. LED Circular Signal Modules:

Provide modules in the following configurations: 12-inch circular sections. All makes and models of LED modules purchased for use on the State Highway System shall appear on the current NCDOT Traffic Signal Qualified Products List (QPL).

Provide the manufacturer's model number and the product number (assigned by the Department) for each module that appears on the 2018 or most recent Qualified Products List. In addition, provide manufacturer's certification in accordance with Article 106-3 of the *Standard Specifications*, that each module meets or exceeds the ITE "Vehicle Traffic Control Signal Heads – Light Emitting Diode (LED) Circular Signal Supplement" dated June 27, 2005 (hereafter referred to as VTCSH Circular Supplement) and other requirements stated in this specification.

Provide modules that meet the following requirements when tested under the procedures outlined in the VTCSH Circular Supplement:

Module Type	Max. Wattage at 165° F	Nominal Wattage at 77° F
12-inch red circular	17	11
12-inch green circular	15	15

For yellow circular signal modules, provide modules tested under the procedures outlined in the VTCSH Circular Supplement to insure power required at 77° F is 22 Watts or less for the 12-inch circular module.

Note: Use a wattmeter having an accuracy of $\pm 1\%$ to measure the nominal wattage and maximum wattage of a circular traffic signal module. Power may also be derived from voltage, current and power factor measurements.

2. LED Arrow Signal Modules

Provide 12-inch omnidirectional arrow signal modules. All makes and models of LED modules purchased for use on the State Highway System shall appear on the current NCDOT Traffic Signal Qualified Products List (QPL).

Provide the manufacturer's model number and the product number (assigned by the Department) for each module that appears on the 2018 or most recent Qualified Products List. In addition, provide manufacturer's certification in accordance with Article 106-3 of the *Standard Specifications*, that each module meets or exceeds the requirements for 12-inch omnidirectional modules specified in the ITE "Vehicle Traffic Control Signal Heads – Light Emitting Diode (LED) Vehicle Arrow Traffic

U-2729**TS-9****Forsyth County**

Signal Supplement” dated July 1, 2007 (hereafter referred to as VTCSH Arrow Supplement) and other requirements stated in this specification.

Provide modules that meet the following requirements when tested under the procedures outlined in the VTCSH Arrow Supplement:

Module Type	Max. Wattage at 165° F	Nominal Wattage at 77° F
12-inch red arrow	12	9
12-inch green arrow	11	11

For yellow arrow signal modules, provide modules tested under the procedures outlined in the VTCSH Arrow Supplement to insure power required at 77° F is 12 Watts or less.

Note: Use a wattmeter having an accuracy of $\pm 1\%$ to measure the nominal wattage and maximum wattage of an arrow traffic signal module. Power may also be derived from voltage, current and power factor measurements.

C. Pedestrian Signal Heads:

Provide pedestrian signal heads with international symbols that meet the MUTCD. Do not provide letter indications.

Comply with the ITE standard for “Pedestrian Traffic Control Signal Indications” and the following sections of the ITE standard for “Vehicle Traffic Control Signal Heads” in effect on the date of advertisement:

- Section 3.00 - “Physical and Mechanical Requirements”
- Section 4.01 - “Housing, Door, and Visor: General”
- Section 4.04 - “Housing, Door, and Visor: Materials and Fabrication”
- Section 7.00 - “Exterior Finish”

Provide a double-row termination block with three empty terminals and number 10 screws for field wiring. Provide barriers between the terminals that accommodate a spade lug sized for number 10 terminal screws. Mount the termination block in the hand section. Wire all signal sections to the terminal block.

Where required by the plans, provide 16-inch pedestrian signal heads with traditional three-sided, rectangular visors, 6 inches long.

Provide 2-inch diameter pedestrian push-buttons with weather-tight housings fabricated from die-cast aluminum and threading in compliance with the NEC for rigid metal conduit. Provide a weep hole in the housing bottom and ensure that the unit is vandal resistant.

Provide push-button housings that are suitable for mounting on flat or curved surfaces and that will accept 1/2-inch conduit installed in the top. Provide units that have a heavy duty push-button assembly with a sturdy, momentary, normally-open switch. Have contacts that are electrically insulated from the housing and push-button. Ensure that the push-buttons are rated for a minimum of 5 mA at 24 volts DC and 250 mA at 12 volts AC.

Provide standard R10-3 signs with mounting hardware that comply with the MUTCD in effect on the date of advertisement. Provide R10-3E signs for countdown pedestrian heads and R10-3B for non-countdown pedestrian heads.

Design the LED pedestrian traffic signal modules (hereafter referred to as modules) for installation into standard pedestrian traffic signal sections that do not contain the incandescent signal section reflector, lens, eggcrate visor, gasket, or socket. Provide modules that consist of an assembly

U-2729

TS-10

Forsyth County

that uses LEDs as the light source in lieu of an incandescent lamp. Use LEDs that are of the latest aluminum indium gallium phosphorus (AlInGaP) technology for the Portland Orange hand and countdown displays. Use LEDs that are of the latest indium gallium nitride (InGaN) technology for the Lunar White walking man displays. Install the ultra-bright type LEDs that are rated for 100,000 hours of continuous operation from -40°F to +165°F. Design modules to have a minimum useful life of 60 months and to meet all parameters of this specification during this period of useful life.

Design all modules to operate using a standard 3 - wire field installation. Provide spade terminals crimped to the lead wires and sized for a #10 screw connection to the existing terminal block in a standard pedestrian signal housing. Do not provide other types of crimped terminals with a spade adapter.

Ensure the power supply is integral to the module assembly. On the back of the module, permanently mark the date of manufacture (month & year) or some other method of identifying date of manufacture.

Provide modules in the following configuration: 16-inch displays which have the solid hand/walking man overlay on the left and the countdown on the right. All makes and models of LED modules purchased for use on the State Highway System shall appear on the current NCDOT Traffic Signal Qualified Products List (QPL).

Provide the manufacturer's model number and the product number (assigned by the Department) for each module that appears on the 2018 or most recent Qualified Products List. In addition, provide manufacturer's certification in accordance with Article 106-3 of the *Standard Specifications*, that each module meets or exceeds the ITE "Pedestrian Traffic Control Signal Indicators - Light Emitting Diode (LED) Signal Modules" dated August 04, 2010 (hereafter referred to as PTCSI Pedestrian Standard) and other requirements stated in this specification.

Provide modules that meet the following requirements when tested under the procedures outlined in the PTCSI Pedestrian Standard:

Module Type	Max. Wattage at 165° F	Nominal Wattage at 77° F
Hand Indication	16	13
Walking Man Indication	12	9
Countdown Indication	16	13

Note: Use a wattmeter having an accuracy of $\pm 1\%$ to measure the nominal wattage and maximum wattage of a circular traffic signal module. Power may also be derived from voltage, current and power factor measurements.

Provide module lens that is hard coated or otherwise made to comply with the material exposure and weathering effects requirements of the Society of Automotive Engineers (SAE) J576. Ensure all exposed components of the module are suitable for prolonged exposure to the environment, without appreciable degradation that would interfere with function or appearance.

Ensure the countdown display continuously monitors the traffic controller to automatically learn the pedestrian phase time and update for subsequent changes to the pedestrian phase time.

Ensure the countdown display begins normal operation upon the completion of the preemption sequence and no more than one pedestrian clearance cycle.

D. Signal Cable:

Furnish 16-4 and 16-7 signal cable that complies with IMSA specification 20-1 except provide the following conductor insulation colors:

U-2729

TS-11

Forsyth County

- For 16-4 cable: white, yellow, red, and green
- For 16-7 cable: white, yellow, red, green, yellow with black stripe tracer, red with black stripe tracer, and green with black stripe tracer. Apply continuous stripe tracer on conductor insulation with a longitudinal or spiral pattern.

Provide a ripcord to allow the cable jacket to be opened without using a cutter. IMSA specification 19-1 will not be acceptable. Provide a cable jacket labeled with the IMSA specification number and provide conductors constructed of stranded copper.

3. CONTROLLERS WITH CABINETS

3.1. MATERIALS – TYPE 2070E CONTROLLERS

Furnish model 2070E controller units that conform to CALTRANS *Transportation Electrical Equipment Specifications* (TEES) (dated March 12, 2009, plus Errata 1 dated January 21, 2010 and Errata 2 dated December 5, 2014) except as required herein.

The Department will provide software at the beginning of the burning-in period. Contractor shall give 5 working days notice before needing software. Program software provided by the Department.

Provide model 2070E controllers with OS-9 release 1.3.1 or later with kernel edition #380 or later operating software and device drivers, composed of the unit chassis and at a minimum the following modules and assemblies:

- MODEL 2070-1E, CPU Module, Single Board, with 8Mb Datakey (blue in color)
- MODEL 2070-2E+, Field I/O Module (FI/O)
 - Note: Configure the Field I/O Module to disable both the External WDT Shunt/Toggle Switch and SP3 (SP3 active indicator is “off”)
- MODEL 2070-3B, Front Panel Module (FP), Display B (8x40)
- MODEL 2070-4A, Power Supply Module, 10 AMP
- MODEL 2070-7A, Async Serial Com Module (9-pin RS-232)

3.2. MATERIALS – GENERAL CABINETS

Provide a moisture resistant coating on all circuit boards.

Provide one 20 mm diameter radial lead UL-recognized metal oxide varistor (MOV) between each load switch field terminal and equipment ground. Electrical performance is outlined below.

PROPERTIES OF MOV SURGE PROTECTOR	
Maximum Continuous Applied Voltage at 185° F	150 VAC (RMS) 200 VDC
Maximum Peak 8x20µs Current at 185° F	6500 A
Maximum Energy Rating at 185° F	80 J
Voltage Range 1 mA DC Test at 77° F	212-268 V
Max. Clamping Voltage 8x20µs, 100A at 77° F	395 V
Typical Capacitance (1 MHz) at 77° F	1600 pF

Provide a power line surge protector that is a two-stage device that will allow connection of the radio frequency interference filter between the stages of the device. Ensure that a maximum continuous current is at least 10A at 120V. Ensure that the device can withstand a minimum of 20 peak surge current occurrences at 20,000A for an 8x20 microsecond waveform. Provide a maximum clamp voltage of 395V at 20,000A with a nominal series inductance of 200 μ h. Ensure that the voltage does not exceed 395V. Provide devices that comply with the following:

Frequency (Hz)	Minimum Insertion Loss (dB)
60	0
10,000	30
50,000	55
100,000	50
500,000	50
2,000,000	60
5,000,000	40
10,000,000	20
20,000,000	25

3.3. MATERIALS – TYPE 170E CABINETS

A. Type 170 E Cabinets General:

Conform to the city of Los Angeles' Specification No. 54-053-08, *Traffic Signal Cabinet Assembly Specification* (dated July 2008), except as required herein.

Furnish model 336S pole mounted cabinets configured for 8 vehicle phases, 4 pedestrian phases, and 6 overlaps. Do not reassign load switches to accommodate overlaps unless shown on electrical details. Provide 336S pole mounted cabinets that are 46" high with 40" high internal rack assemblies.

Furnish model 332 base mounted cabinets configured for 8 vehicle phases, 4 pedestrian phases, and 6 overlaps. When overlaps are required, provide auxiliary output files for the overlaps. Do not reassign load switches to accommodate overlaps unless shown on electrical details.

Provide model 200 load switches, model 222 loop detector sensors, model 252 AC isolators, and model 242 DC isolators according to the electrical details. As a minimum, provide one (1) model 2018 conflict monitor, one (1) model 206L power supply unit, two (2) model 204 flashers, one (1) DC isolator (located in slot I14), and four (4) model 430 flash transfer relays (provide seven (7) model 430 flash transfer relays if auxiliary output file is installed) with each cabinet.

Removal of existing signal cabinet and equipment will be delivered to the City of Winston-Salem Department of Transportation, Traffic Maintenance Building at 651 Paul Howell Drive, Winston-Salem NC 27101

B. Type 170 E Cabinet Electrical Requirements:

Provide a cabinet assembly designed to ensure that upon leaving any cabinet switch or conflict monitor initiated flashing operation, the controller starts up in the programmed start up phases and start up interval.

Furnish two sets of non-fading cabinet wiring diagrams and schematics in a paper envelope or container and placed in the cabinet drawer.

All AC+ power is subject to radio frequency signal suppression.

Provide surge suppression in the cabinet for each type of cabinet device. Provide surge protection for the full capacity of the cabinet input file. Provide surge suppression devices that operate properly over a temperature range of -40° F to +185° F. Ensure the surge suppression devices provide both common and differential modes of protection.

Provide a pluggable power line surge protector that is installed on the back of the PDA (power distribution assembly) chassis to filter and absorb power line noise and switching transients. Ensure the device incorporates LEDs for failure indication and provides a dry relay contact closure for the purpose of remote sensing. Ensure the device meets the following specifications:

Peak Surge Current (Single pulse, 8x20µs).....20,000A
 Occurrences (8x20µs waveform).....10 minimum @ 20,000A
 Maximum Clamp Voltage.....395VAC
 Operating Current.....15 amps
 Response Time.....< 5 nanoseconds

Provide a loop surge suppressor for each set of loop terminals in the cabinet. Ensure the device meets the following specifications:

Peak Surge Current (6 times, 8x20µs)
 (Differential Mode).....400A
 (Common Mode).....1,000A
 Occurrences (8x20µs waveform).....500 min @ 200A
 Maximum Clamp Voltage
 (Differential Mode @400A).....35V
 (Common Mode @1,000A).....35V
 Response Time.....< 5 nanoseconds
 Maximum Capacitance.....35 pF

Provide a data communications surge suppressor for each communications line entering or leaving the cabinet. Ensure the device meets the following specifications:

Peak Surge Current (Single pulse, 8x20µs).....10,000A
 Occurrences (8x20µs waveform).....100 min @ 2,000A
 Maximum Clamp Voltage.....Rated for equipment protected
 Response Time.....< 1 nanosecond
 Maximum Capacitance.....1,500 pF
 Maximum Series Resistance.....15Ω

Provide a DC signal surge suppressor for each DC input channel in the cabinet. Ensure the device meets the following specifications:

- Peak Surge Current (Single pulse, 8x20µs).....10,000A
- Occurrences (8x20µs waveform).....100 @ 2,000A
- Maximum Clamp Voltage.....30V
- Response Time.....< 1 nanosecond

Provide a 120 VAC signal surge suppressor for each AC+ interconnect signal input. Ensure the device meets the following specifications:

- Peak Surge Current (Single pulse, 8x20µs).....20,000A
- Maximum Clamp Voltage.....350VAC
- Response Time.....< 200 nanoseconds
- Discharge Voltage.....<200 Volts @ 1,000A
- Insulation Resistance.....≥100 MΩ

Provide conductors for surge protection wiring that are of sufficient size (ampacity) to withstand maximum overcurrents which could occur before protective device thresholds are attained and current flow is interrupted.

If additional surge protected power outlets are needed to accommodate fiber transceivers, modems, etc., install a UL listed, industrial, heavy-duty type power outlet strip with a minimum rating of 15 A / 125 VAC, 60 Hz. Provide a strip that has a minimum of 3 grounded outlets. Ensure the power outlet strip plugs into one of the controller unit receptacles located on the rear of the PDA. Ensure power outlet strip is mounted securely; provide strain relief if necessary.

Provide a door switch in the front and a door switch in the rear of the cabinet that will provide the controller unit with a Door Ajar alarm when either the front or the rear door is open. Ensure the door switches apply DC ground to the Input File when either the front door or the rear door is open.

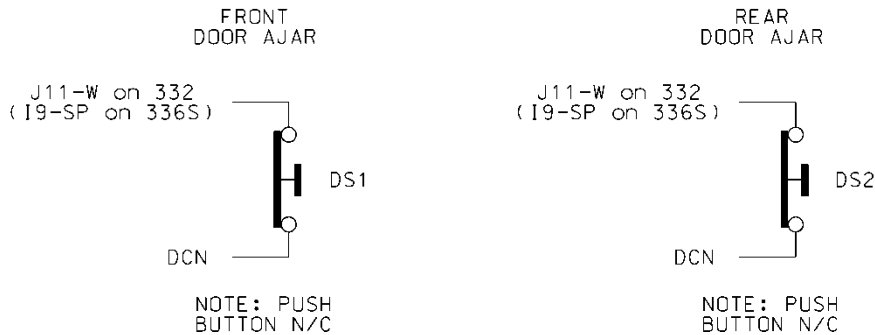

Furnish a fluorescent fixture in the rear across the top of the cabinet and another fluorescent fixture in the front across the top of the cabinet at a minimum. Ensure that the fixtures provide sufficient light to illuminate all terminals, labels, switches, and devices in the cabinet. Conveniently

U-2729

TS-15

Forsyth County

locate the fixtures so as not to interfere with a technician's ability to perform work on any devices or terminals in the cabinet. Provide a protective diffuser to cover exposed bulbs. Install 16 watt T-4 lamps in the fluorescent fixtures. Provide a door switch to provide power to each fixture when the respective door is open. Wire the fluorescent fixtures to the 15 amp ECB (equipment circuit breaker).

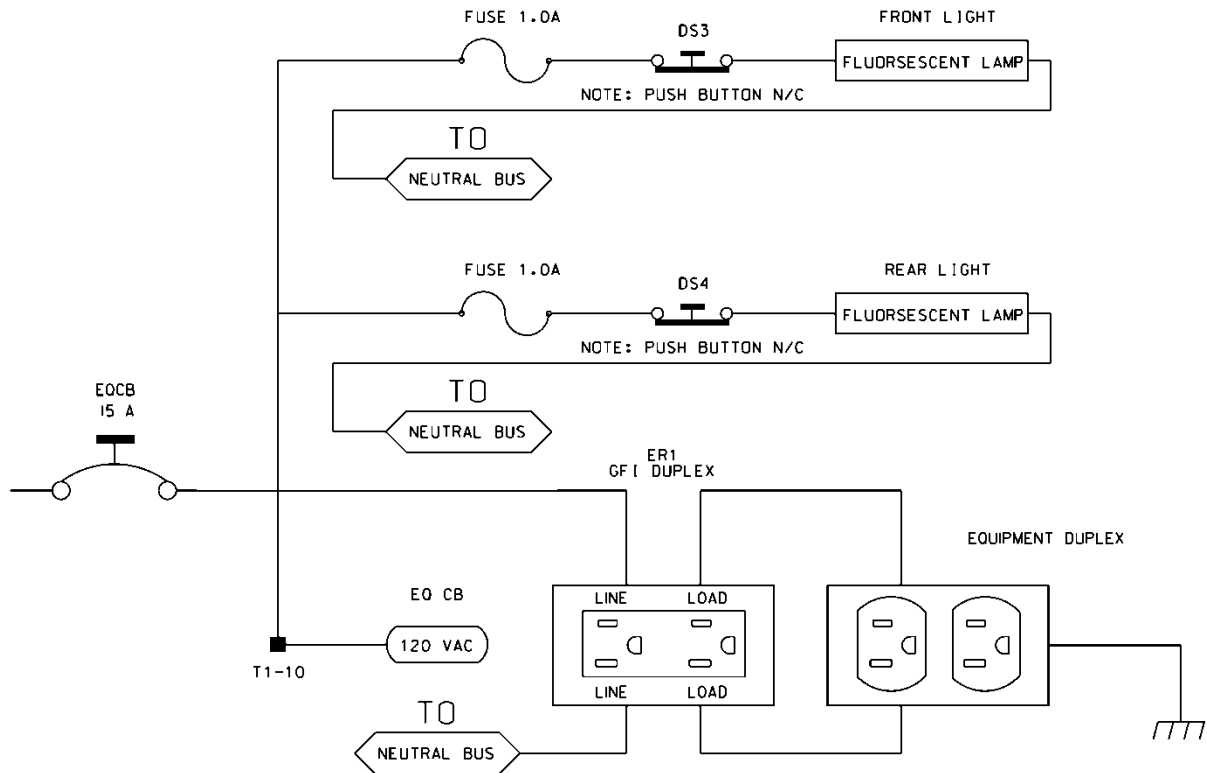

Furnish a police panel with a police panel door. For model 336S cabinets, mount the police panel on the rear door. Ensure that the police panel door permits access to the police panel when the main door is closed. Ensure that no rainwater can enter the cabinet even with the police panel door open. Provide a police panel door hinged on the right side as viewed from the front. Provide a police panel door lock that is keyed to a standard police/fire call box key. In addition to the requirements of LA Specification No. 54-053-08, provide the police panel with a toggle switch connected to switch the intersection operation between normal stop-and-go operation (AUTO) and manual operation (MANUAL). Ensure that manual control can be implemented using inputs and software such that the controller provides full programmed clearance times for the yellow clearance and red clearance for each phase while under manual control.

Provide a 1/4-inch locking phone jack in the police panel for a hand control to manually control the intersection. Provide sufficient room in the police panel for storage of a hand control and cord.

Ensure the 336S cabinet Input File is wired as follows:

U-2729

TS-16

Forsyth County

336S Cabinet														
Port-Bit/C-1 Pin Assignment														
Slot #	1	2	3	4	5	6	7	8	9	10	11	12	13	14
C-1 (Spares)	59	60	61	62	63	64	65	66	75	76	77	78	79	80
Port C-1	3-2 56	1-1 39	3-4 58	1-3 41	3-1 55	1-2 40	3-3 57	1-4 42	2-5 51	5-5 71	5-6 72	5-1 67	5-2 68	6-7 81
Port C-1	2-1 47	1-5 43	2-3 49	1-7 45	2-2 48	1-6 44	2-4 50	1-8 46	2-6 52	5-7 73	5-8 74	5-3 69	5-4 70	6-8 82

For model 332 base mounted cabinets, ensure terminals J14-E and J14-K are wired together on the rear of the Input File. Connect TB9-12 (J14 Common) on the Input Panel to T1-2 (AC-) on the rear of the PDA.

Provide detector test switches mounted at the top of the cabinet rack or other convenient location which may be used to place a call on each of eight phases based on the chart below. Provide three positions for each switch: On (place call), Off (normal detector operation), and Momentary On (place momentary call and return to normal detector operation after switch is released). Ensure that the switches are located such that the technician can read the controller display and observe the intersection.

Connect detector test switches for cabinets as follows:

336S Cabinet		332 Cabinet	
Detector Call Switches	Terminals	Detector Call Switches	Terminals
Phase 1	I1-F	Phase 1	I1-W
Phase 2	I2-F	Phase 2	I4-W
Phase 3	I3-F	Phase 3	I5-W
Phase 4	I4-F	Phase 4	I8-W
Phase 5	I5-F	Phase 5	J1-W
Phase 6	I6-F	Phase 6	J4-W
Phase 7	I7-F	Phase 7	J5-W
Phase 8	I8-F	Phase 8	J8-W

Provide the PCB 28/56 connector for the conflict monitor unit (CMU) with 28 independent contacts per side, dual-sided with 0.156 inch contact centers. Provide the PCB 28/56 connector contacts with solder eyelet terminations. Ensure all connections to the PCB 28/56 connector are soldered to the solder eyelet terminations.

Ensure that all cabinets have the CMU connector wired according to the 332 cabinet connector pin assignments (include all wires for auxiliary output file connection). Wire pins 13, 16, R, and U of the CMU connector to a separate 4 pin plug, P1, as shown below. Provide a second plug, P2, which will mate with P1 and is wired to the auxiliary output file as shown below. Provide an additional plug, P3, which will mate with P1 and is wired to the pedestrian yellow circuits as shown

U-2729

TS-17

Forsyth County

below. When no auxiliary output file is installed in the cabinet, provide wires for the green and yellow inputs for channels 11, 12, 17, and 18, the red inputs for channels 17 and 18, and the wires for the P2 plug. Terminate the two-foot wires with ring type lugs, insulated, and bundled for optional use.

PIN	P1		P2		P3	
	FUNCTION	CONN TO	FUNCTION	CONN TO	FUNCTION	CONN TO
1	CH-9G	CMU-13	OLA-GRN	A123	2P-YEL	114
2	CH-9Y	CMU-16	OLA-YEL	A122	4P-YEL	105
3	CH-10G	CMU-R	OLB-GRN	A126	6P-YEL	120
4	CH-10Y	CMU-U	OLB-YEL	A125	8P-YEL	111

Do not provide the P20 terminal assembly (red monitor board) or red interface ribbon cable as specified in LA Specification No. 54-053-08.

Provide a P20 connector that mates with and is compatible with the red interface connector mounted on the front of the conflict monitor. Ensure that the P20 connector and the red interface connector on the conflict monitor are center polarized to ensure proper connection. Ensure that removal of the P20 connector will cause the conflict monitor to recognize a latching fault condition and place the cabinet into flashing operation.

Wire the P20 connector to the output file and auxiliary output file using 22 AWG stranded wires. Ensure the length of these wires is a minimum of 42 inches in length. Provide a durable braided sleeve around the wires to organize and protect the wires.

Wire the P20 connector to the traffic signal red displays to provide inputs to the conflict monitor as shown below. Ensure the pedestrian Don't Walk circuits are wired to channels 13 through 16 of the P20 connector. When no auxiliary output file is installed in the cabinet, provide wires for channels 9 through 12 reds. Provide a wire for special function 1. Terminate the unused wires with ring type lugs, insulated, and bundled for optional use.

P20 Connector					
PIN	FUNCTION	CONN TO	PIN	FUNCTION	CONN TO
1	Channel 15 Red	119	2	Channel 16 Red	110
3	Channel 14 Red	104	4	Chassis GND	01-9
5	Channel 13 Red	113	6	N/C	
7	Channel 12 Red	AUX 101	8	Spec Function 1	
9	Channel 10 Red	AUX 124	10	Channel 11 Red	AUX 114
11	Channel 9 Red	AUX 121	12	Channel 8 Red	107

13	Channel 7 Red	122	14	Channel 6 Red	134
15	Channel 5 Red	131	16	Channel 4 Red	101
17	Channel 3 Red	116	18	Channel 2 Red	128
19	Channel 1 Red	125	20	Red Enable	01-14

Ensure the controller unit outputs to the auxiliary output file are pre-wired to the C5 connector. When no auxiliary output file is installed in the cabinet, connect the C5 connector to a storage socket located on the Input Panel or on the rear of the PDA.

Do not wire pin 12 of the load switch sockets.

In addition to the requirements of LA Specification No. 54-053-08, ensure relay K1 on the Power Distribution Assembly (PDA) is a four pole relay and K2 on the PDA is a two pole relay.

Provide a two pole, ganged circuit breaker for the flash bus circuit. Ensure the flash bus circuit breaker is an inverse time circuit breaker rated for 10 amps at 120 VAC with a minimum of 10,000 RMS symmetrical amperes short circuit current rating. Do not provide the auxiliary switch feature on the flash bus circuit breaker. Ensure the ganged flash bus circuit breaker is certified by the circuit breaker manufacturer to provide gang tripping operation.

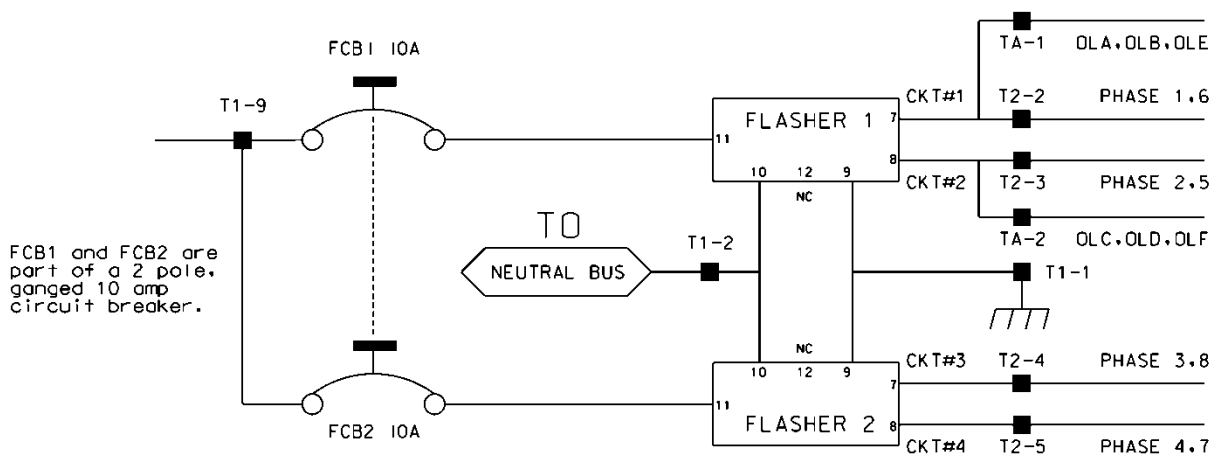

Ensure auxiliary output files are wired as follows:

U-2729

TS-19

Forsyth County

AUXILIARY OUTPUT FILE TERMINAL BLOCK TA ASSIGNMENTS	
POSITION	FUNCTION
1	Flasher Unit #1, Circuit 1/FTR1 (OLA, OLB)/FTR3 (OLE)
2	Flasher Unit #1, Circuit 2/FTR2 (OLC, OLD)/FTR3 (OLF)
3	Flash Transfer Relay Coils
4	AC -
5	Power Circuit 5
6	Power Circuit 5
7	Equipment Ground Bus
8	NC

Provide four spare load resistors mounted in each cabinet. Ensure each load resistor is rated as shown in the table below. Wire one side of each load resistor to AC-. Connect the other side of each resistor to a separate terminal on a four (4) position terminal block. Mount the load resistors and terminal block either inside the back of Output File No. 1 or on the upper area of the Service Panel.

ACCEPTABLE LOAD RESISTOR VALUES	
VALUE (ohms)	WATTAGE
1.5K – 1.9 K	25W (min)
2.0K – 3.0K	10W (min)

Provide Model 200 load switches, Model 204 flashers, Model 242 DC isolators, Model 252 AC isolators, and Model 206L power supply units that conform to CALTRANS' "Transportation Electrical Equipment Specifications" dated March 12, 2009 with Erratum 1.

C. Type 170 E Cabinet Physical Requirements:

Do not mold, cast, or scribe the name "City of Los Angeles" on the outside of the cabinet door as specified in LA Specification No. 54-053-08. Do not provide a Communications Terminal Panel as specified in LA Specification No. 54-053-08. Do not provide terminal block TBB on the Service Panel. Do not provide Cabinet Verification Test Program software or associated test jigs as specified in LA Specification No. 54-053-08.

Furnish unpainted, natural, aluminum cabinet shells. Ensure that all non-aluminum hardware on the cabinet is stainless steel or a Department approved non-corrosive alternate.

Ensure the lifting eyes, gasket channels, police panel, and all supports welded to the enclosure and doors are fabricated from 0.125 inch minimum thickness aluminum sheet and meet the same standards as the cabinet and doors.

Provide front and rear doors with latching handles that allow padlocking in the closed position. Furnish 0.75 inch minimum diameter stainless steel handles with a minimum 0.5 inch shank. Place

U-2729**TS-20****Forsyth County**

the padlocking attachment at 4.0 inches from the handle shank center to clear the lock and key. Provide an additional 4.0 inches minimum gripping length.

Provide Corbin #2 locks on the front and rear doors. Provide one (1) Corbin #2 and one (1) police master key with each cabinet. Ensure main door locks allow removal of keys in the locked position only.

Provide a surge protection panel with 16 loop surge protection devices and designed to allow sufficient free space for wire connection/disconnection and surge protection device replacement. For model 332 cabinets, provide an additional 20 loop surge protection devices. Provide an additional two AC+ interconnect surge devices to protect one slot and eight DC surge protection devices to protect four slots. Provide no protection devices on slot I14.

For pole mounted cabinets, mount surge protection devices for the AC+ interconnect inputs, inductive loop detector inputs, and low voltage DC inputs on a swing down panel assembly fabricated from sturdy aluminum. Attach the swing down panel to the bottom rear cabinet rack assembly using thumb screws. Ensure the swing down panel allows for easy removal of the input file without removing the surge protection panel assembly or its parts. Have the surge protection devices mounted horizontally on the panel and soldered to the feed through terminals of four 14 position terminal blocks with #8 screws mounted on the other side. Ensure the top row of terminals is connected to the upper slots and the bottom row of terminals is connected to the bottom slots. Provide a 15 position copper equipment ground bus attached to the field terminal side (outside) of the swing down panel for termination of loop lead-in shield grounds. Ensure that a Number 4 AWG green wire connects the surge protection panel assembly ground bus to the main cabinet equipment ground.

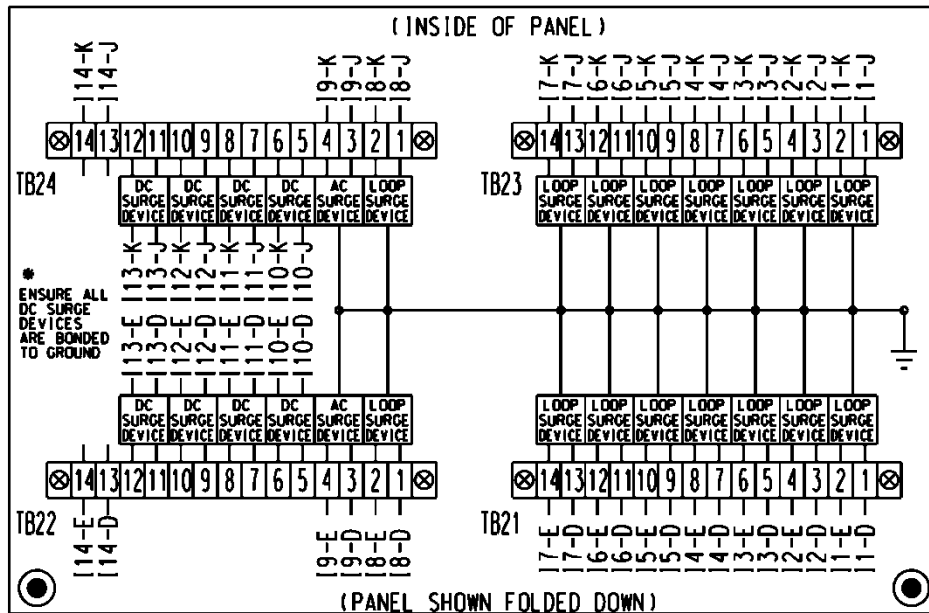
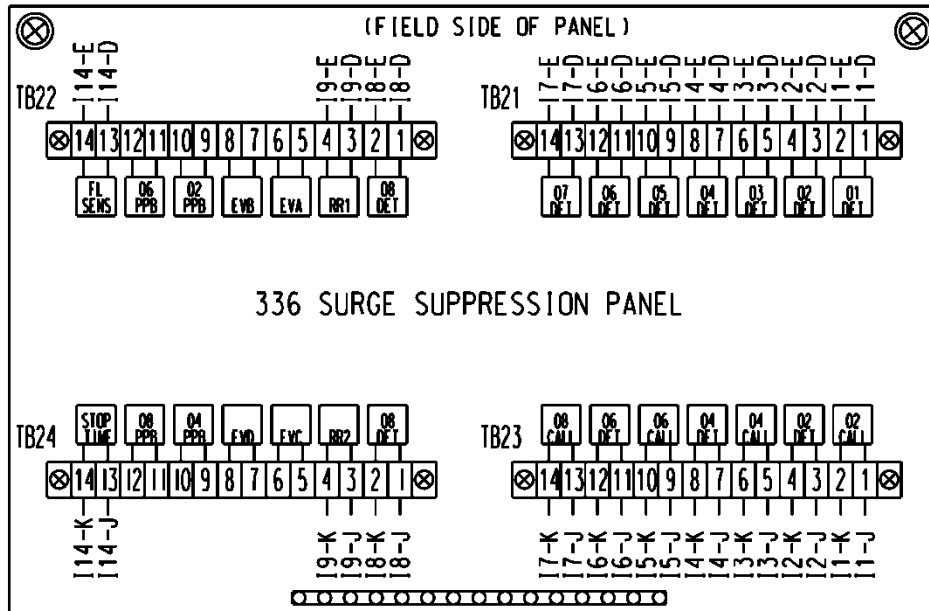

For base mounted cabinets, mount surge protection panels on the left side of the cabinet as viewed from the rear. Attach each panel to the cabinet rack assembly using bolts and make it easily removable. Mount the surge protection devices in vertical rows on each panel and connect the devices to one side of 12 position, double row terminal blocks with #8 screws. For each surge protection panel, terminate all grounds from the surge protection devices on a copper equipment ground bus attached to the surge protection panel. Wire the terminals to the rear of a standard input file using spade lugs for input file protection.

Provide permanent labels that indicate the slot and the pins connected to each terminal that may be viewed from the rear cabinet door. Label and orient terminals so that each pair of inputs is next to each other. Indicate on the labeling the input file (I or J), the slot number (1-14) and the terminal pins of the input slots (either D & E for upper or J & K for lower).

Provide a minimum 14 x 16 inch pull out, hinged top shelf located immediately below controller mounting section of the cabinet. Ensure the shelf is designed to fully expose the table surface outside the controller at a height approximately even with the bottom of the controller. Ensure the shelf has a storage bin interior which is a minimum of 1 inch deep and approximately the same dimensions as the shelf. Provide an access to the storage area by lifting the hinged top of the shelf. Fabricate the shelf and slide from aluminum or stainless steel and ensure the assembly can support the 2070L controller plus 15 pounds of additional weight. Ensure shelf has a locking mechanism to secure it in the fully extended position and does not inhibit the removal of the 2070L controller or removal of cards inside the controller when fully extended. Provide a locking mechanism that is easily released when the shelf is to be returned to its non-use position directly under the controller.

D. Model 2018 Enhanced Conflict Monitor:

Furnish Model 2018 Enhanced Conflict Monitors that provide monitoring of 18 channels. Ensure each channel consists of a green, yellow, and red field signal input. Ensure that the conflict monitor meets or exceeds CALTRANS' Transportation Electrical Equipment Specifications dated March 12, 2009, with Erratum 1 (hereafter referred to as CALTRANS' 2009 TEES) for a model 210 monitor unit and other requirements stated in this specification.

Ensure the conflict monitor is provided with an 18 channel conflict programming card. Pin EE and Pin T of the conflict programming card shall be connected together. Pin 16 of the conflict programming card shall be floating. Ensure that the absence of the conflict programming card will cause the conflict monitor to trigger (enter into fault mode), and remain in the triggered state until the programming card is properly inserted and the conflict monitor is reset.

Provide a conflict monitor that incorporates LED indicators into the front panel to dynamically display the status of the monitor under normal conditions and to provide a comprehensive review of field inputs with monitor status under fault conditions. Ensure that the monitor indicates the channels that were active during a conflict condition and the channels that experienced a failure for all other per channel fault conditions detected. Ensure that these indications and the status of each channel are retained until the Conflict Monitor is reset. Furnish LED indicators for the following:

- AC Power (Green LED indicator)
- VDC Failed (Red LED indicator)
- WDT Error (Red LED indicator)
- Conflict (Red LED indicator)
- Red Fail (Red LED indicator)
- Dual Indication (Red LED indicator)
- Yellow/Clearance Failure (Red LED indicator)
- PCA/PC Ajar (Red LED indicator)
- Monitor Fail/Diagnostic Failure (Red LED indicator)
- 54 Channel Status Indicators (1 Red, 1 Yellow, and 1 Green LED indicator for each of the 18 channels)

Provide a switch to set the Red Fail fault timing. Ensure that when the switch is in the ON position the Red Fail fault timing value is set to 1350 +/- 150 ms (2018 mode). Ensure that when the switch is in the OFF position the Red Fail fault timing value is set to 850 +/- 150 ms (210 mode).

Provide a switch to set the Watchdog fault timing. Ensure that when the switch is in the ON position the Watchdog fault timing value is set to 1.0 +/- 0.1 s (2018 mode). Ensure that when the switch is in the OFF position the Watchdog fault timing value is set to 1.5 +/- 0.1 s (210 mode).

Provide a jumper or switch to set the AC line brown-out levels. Ensure that when the jumper is present or the switch is in the ON position the AC line dropout voltage threshold is 98 +/- 2 Vrms, the AC line restore voltage threshold is 103 +/- 2 Vrms, and the AC line brown-out timing value is set to 400 +/- 50ms (2018 mode). Ensure that when the jumper is not present or the switch is in the OFF position the AC line dropout voltage threshold is 92 +/- 2 Vrms, the AC line restore voltage threshold is 98 +/- 2 Vrms, and the AC line brown-out timing value is set to 80 +/- 17 ms (210 mode).

Provide a jumper or switch that will enable and disable the Watchdog Latch function. Ensure that when the jumper is not present or the switch is in the OFF position the Watchdog Latch function is disabled. In this mode of operation, a Watchdog fault will be reset following a power loss, brownout, or power interruption. Ensure that when the jumper is present or the switch is in the ON position the Watchdog Latch function is enabled. In this mode of operation, a Watchdog fault will be retained until a Reset command is issued.

Provide a jumper that will reverse the active polarity for pin #EE (output relay common). Ensure that when the jumper is not present pin #EE (output relay common) will be considered 'Active' at a voltage greater than 70 Vrms and 'Not Active' at a voltage less than 50 Vrms (Caltrans mode). Ensure that when the jumper is present pin #EE (output relay common) will be considered 'Active' at a voltage less than 50 Vrms and 'Not Active' at a voltage greater than 70 Vrms (Failsafe mode).

In addition to the connectors required by CALTRANS' 2009 TEES, provide the conflict monitor with a red interface connector mounted on the front of the monitor. Ensure the connector is a 20 pin, right angle, center polarized, male connector with latching clip locks and polarizing keys. Ensure the right angle solder tails are designed for a 0.062" thick printed circuit board. Keying of the connector shall be between pins 3 and 5, and between 17 and 19. Ensure the connector has two rows of pins with the odd numbered pins on one row and the even pins on the other row. Ensure the connector pin row spacing is 0.10" and pitch is 0.10". Ensure the mating length of the connector pins is 0.24". Ensure the pins are finished with gold plating 30μ" thick.

U-2729

TS-24

Forsyth County

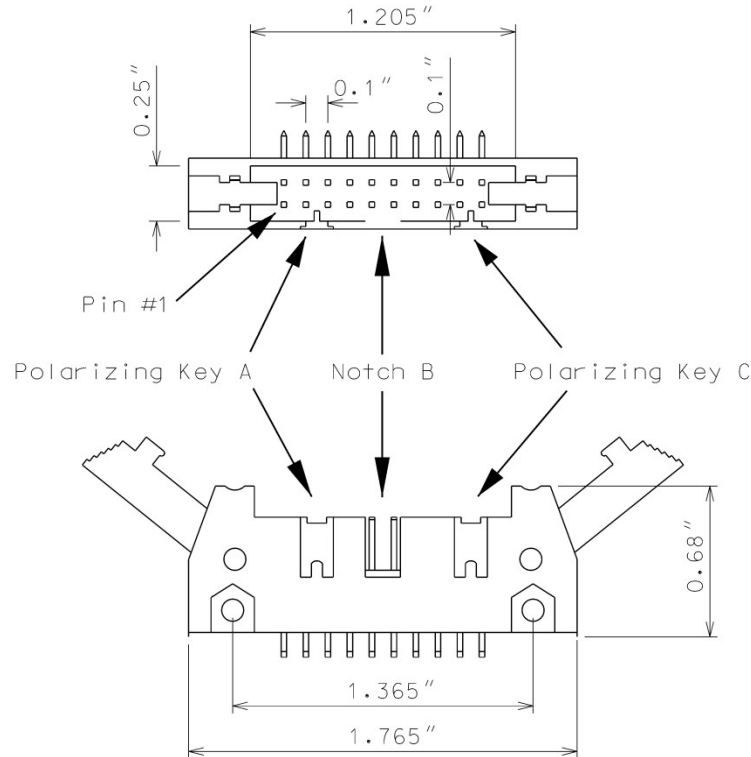

Ensure the red interface connector pins on the monitor have the following functions:

Pin #	Function	Pin #	Function
1	Channel 15 Red	2	Channel 16 Red
3	Channel 14 Red	4	Chassis Ground
5	Channel 13 Red	6	Special Function 2
7	Channel 12 Red	8	Special Function 1
9	Channel 10 Red	10	Channel 11 Red
11	Channel 9 Red	12	Channel 8 Red
13	Channel 7 Red	14	Channel 6 Red
15	Channel 5 Red	16	Channel 4 Red
17	Channel 3 Red	18	Channel 2 Red
19	Channel 1 Red	20	Red Enable

Ensure that removal of the P20 cable connector will cause the conflict monitor to recognize a latching fault condition and place the cabinet into flashing operation.

Provide Special Function 1 and Special Function 2 inputs to the unit which shall disable only Red Fail Monitoring when either input is sensed active. A Special Function input shall be sensed active when the input voltage exceeds 70 Vrms with a minimum duration of 550 ms. A Special Function input shall be sensed not active when the input voltage is less than 50 Vrms or the duration is less

than 250 ms. A Special Function input is undefined by these specifications and may or may not be sensed active when the input voltage is between 50 Vrms and 70 Vrms or the duration is between 250 ms and 550 ms.

Ensure the conflict monitor recognizes field signal inputs for each channel that meet the following requirements:

- consider a Red input greater than 70 Vrms and with a duration of at least 500 ms as an “on” condition;
- consider a Red input less than 50 Vrms or with a duration of less than 200 ms as an “off” condition (no valid signal);
- consider a Red input between 50 Vrms and 70 Vrms or with a duration between 200 ms and 500 ms to be undefined by these specifications;
- consider a Green or Yellow input greater than 25 Vrms and with a duration of at least 500 ms as an “on” condition;
- consider a Green or Yellow input less than 15 Vrms or with a duration of less than 200 ms as an “off” condition; and
- consider a Green or Yellow input between 15 Vrms and 25 Vrms or with a duration between 200 ms and 500 ms to be undefined by these specifications.

Provide a conflict monitor that recognizes the faults specified by CALTRANS’ 2009 TEES and the following additional faults. Ensure the conflict monitor will trigger upon detection of a fault and will remain in the triggered (in fault mode) state until the unit is reset at the front panel or through the external remote reset input for the following failures:

1. **Red Monitoring or Absence of Any Indication (Red Failure):** A condition in which no “on” voltage signal is detected on any of the green, yellow, or red inputs to a given monitor channel. If a signal is not detected on at least one input (R, Y, or G) of a conflict monitor channel for a period greater than 1000 ms when used with a 170 controller and 1500 ms when used with a 2070 controller, ensure monitor will trigger and put the intersection into flash. If the absence of any indication condition lasts less than 700 ms when used with a 170 controller and 1200 ms when used with a 2070 controller, ensure conflict monitor will not trigger. Red fail monitoring shall be enabled on a per channel basis by the use of switches located on the conflict monitor. Have red monitoring occur when all of the following input conditions are in effect:
 - a) Red Enable input to monitor is active (Red Enable voltages are “on” at greater than 70 Vrms, off at less than 50 Vrms, undefined between 50 and 70 Vrms), and
 - b) Neither Special Function 1 nor Special Function 2 inputs are active.
 - c) Pin #EE (output relay common) is not active
2. **Short/Missing Yellow Indication Fault (Clearance Error):** Yellow indication following a green is missing or shorter than 2.7 seconds (with ± 0.1 -second accuracy). If a channel fails to detect an “on” signal at the Yellow input for a minimum of 2.7 seconds (± 0.1 second) following the detection of an “on” signal at a Green input for that channel, ensure that the monitor triggers and generates a clearance/short yellow error fault indication. Short/missing

yellow (clearance) monitoring shall be enabled on a per channel basis by the use of switches located on the conflict monitor. This fault shall not occur when the channel is programmed for Yellow Inhibit, when the Red Enable signal is inactive or pin #EE (output relay common) is active.

3. **Dual Indications on the Same Channel:** In this condition, more than one indication (R,Y,G) is detected as “on” at the same time on the same channel. If dual indications are detected for a period greater than 500 ms, ensure that the conflict monitor triggers and displays the proper failure indication (Dual Ind fault). If this condition is detected for less than 200 ms, ensure that the monitor does not trigger. G-Y-R dual indication monitoring shall be enabled on a per channel basis by the use of switches located on the conflict monitor. G-Y dual indication monitoring shall be enabled for all channels by use of a switch located on the conflict monitor. This fault shall not occur when the Red Enable signal is inactive or pin #EE (output relay common) is active.
4. **Configuration Settings Change:** The configuration settings are comprised of (as a minimum) the permissive diode matrix, dual indication switches, yellow disable jumpers, any option switches, any option jumpers, and the Watchdog Enable switch. Ensure the conflict monitor compares the current configuration settings with the previous stored configuration settings on power-up, on reset, and periodically during operation. If any of the configuration settings are changed, ensure that the conflict monitor triggers and causes the program card indicator to flash. Ensure that configuration change faults are only reset by depressing and holding the front panel reset button for a minimum of three seconds. Ensure the external remote reset input does not reset configuration change faults.

Ensure the conflict monitor will trigger and the AC Power indicator will flash at a rate of 2 Hz \pm 20% with a 50% duty cycle when the AC Line voltage falls below the “drop-out” level. Ensure the conflict monitor will resume normal operation when the AC Line voltage returns above the “restore” level. Ensure the AC Power indicator will remain illuminated when the AC voltage returns above the “restore” level. Should an AC Line power interruption occur while the monitor is in the fault mode, then upon restoration of AC Line power, the monitor will remain in the fault mode and the correct fault and channel indicators will be displayed.

Provide a flash interval of at least 6 seconds and at most 10 seconds in duration following a power-up, an AC Line interruption, or a brownout restore. Ensure the conflict monitor will suspend all fault monitoring functions, close the Output relay contacts, and flash the AC indicator at a rate of 4 Hz \pm 20% with a 50% duty cycle during this interval. Ensure the termination of the flash interval after at least 6 seconds if the Watchdog input has made 5 transitions between the True and False state and the AC Line voltage is greater than the “restore” level. If the watchdog input has not made 5 transitions between the True and False state within 10 \pm 0.5 seconds, the monitor shall enter a WDT error fault condition.

Ensure the conflict monitor will monitor an intersection with a minimum of four approaches using the four-section Flashing Yellow Arrow (FYA) vehicle traffic signal as outlined by the NCHRP 3-54 research project for protected-permissive left turn signal displays. Ensure the conflict monitor will operate in the FYA mode and FYAc (Compact) mode as specified below to monitor each channel pair for the following fault conditions: Conflict, Flash Rate Detection, Red Fail, Dual Indication, and

U-2729

TS-27

Forsyth County

Clearance. Provide a switch to select between the FYA mode and FYAc mode. Provide a switch to select each FYA phase movement for monitoring.

FYA mode

FYA Signal Head	Phase 1	Phase 3	Phase 5	Phase 7
Red Arrow	Channel 9 Red	Channel 10 Red	Channel 11 Red	Channel 12 Red
Yellow Arrow	Channel 9 Yellow	Channel 10 Yellow	Channel 11 Yellow	Channel 12 Yellow
Flashing Yellow Arrow	Channel 9 Green	Channel 10 Green	Channel 11 Green	Channel 12 Green
Green Arrow	Channel 1 Green	Channel 3 Green	Channel 5 Green	Channel 7 Green

FYAc mode

FYA Signal Head	Phase 1	Phase 3	Phase 5	Phase 7
Red Arrow	Channel 1 Red	Channel 3 Red	Channel 5 Red	Channel 7 Red
Yellow Arrow	Channel 1 Yellow	Channel 3 Yellow	Channel 5 Yellow	Channel 7 Yellow
Flashing Yellow Arrow	Channel 1 Green	Channel 3 Green	Channel 5 Green	Channel 7 Green
Green Arrow	Channel 9 Green	Channel 9 Yellow	Channel 10 Green	Channel 10 Yellow

If a FYA channel pair is enabled for FYA operation, the conflict monitor will monitor the FYA logical channel pair for the additional following conditions:

1. **Conflict:** Channel conflicts are detected based on the permissive programming jumpers on the program card. This operation remains unchanged from normal operation except for the solid Yellow arrow (FYA clearance) signal.
2. **Yellow Change Interval Conflict:** During the Yellow change interval of the Permissive Turn channel (flashing Yellow arrow) the conflict monitor shall verify that no conflicting channels to the solid Yellow arrow channel (clearance) are active. These conflicting channels shall be determined by the program card compatibility programming of the Permissive Turn channel (flashing Yellow arrow). During the Yellow change interval of the Protected Turn channel (solid Green arrow) the conflict monitor shall verify that no conflicting channels to the solid Yellow arrow channel (clearance) are active as determined by the program card compatibility programming of the Protected Turn channel (solid Green arrow).

3. **Flash Rate Detection:** The conflict monitor unit shall monitor for the absence of a valid flash rate for the Permissive turn channel (flashing Yellow arrow). If the Permissive turn channel (flashing Yellow arrow) is active for a period greater than 1600 milliseconds, ensure the conflict monitor triggers and puts the intersection into flash. If the Permissive turn channel (flashing Yellow arrow) is active for a period less than 1400 milliseconds, ensure the conflict monitor does not trigger. Ensure the conflict monitor will remain in the triggered (in fault mode) state until the unit is reset at the front panel or through the external remote reset input. Provide a jumper or switch that will enable and disable the Flash Rate Detection function. Ensure that when the jumper is not present or the switch is in the OFF position the Flash Rate Detection function is enabled. Ensure that when the jumper is present or the switch is in the ON position the Flash Rate Detection function is disabled.
4. **Red Monitoring or Absence of Any Indication (Red Failure):** The conflict monitor unit shall detect a red failure if there is an absence of voltage on all four of the inputs of a FYA channel pair (RA, YA, FYA, GA).
5. **Dual Indications on the Same Channel:** The conflict monitor unit shall detect a dual indication if two or more inputs of a FYA channel pair (RA, YA, FYA, GA) are “on” at the same time.
6. **Short/Missing Yellow Indication Fault (Clearance Error):** The conflict monitor unit shall monitor the solid Yellow arrow for a clearance fault when terminating both the Protected Turn channel (solid Green arrow) interval and the Permissive Turn channel (flashing Yellow arrow) interval.

Ensure that the conflict monitor will log at least nine of the most recent events detected by the monitor in non-volatile EEPROM memory (or equivalent). For each event, record at a minimum the time, date, type of event, status of each field signal indication with RMS voltage, and specific channels involved with the event. Ensure the conflict monitor will log the following events: monitor reset, configuration, previous fault, and AC line. Furnish the signal sequence log that shows all channel states (Greens, Yellows, and Reds) and the Red Enable State for a minimum of 2 seconds prior to the current fault trigger point. Ensure the display resolution of the inputs for the signal sequence log is not greater than 50 ms.

For conflict monitors used within an Ethernet communications system, provide a conflict monitor with an Ethernet 10/100 Mbps, RJ-45 port for data communication access to the monitor by a local notebook computer and remotely via a workstation or notebook computer device connected to the signal system local area network. The Ethernet port shall be electrically isolated from the conflict monitor’s electronics and shall provide a minimum of 1500 Vrms isolation. Integrate monitor with Ethernet network in cabinet. Provide software to retrieve the time and date from a network server in order to synchronize the on-board times between the conflict monitor and the controller. Furnish and install the following Windows based, graphic user interface software on workstations and notebook computers where the signal system client software is installed: 1) software to view and retrieve all event log information, 2) software that will search and display a list of conflict monitor IP addresses and IDs on the network, and 3) software to change the conflict monitor’s network parameters such as IP address and subnet mask.

For non-Ethernet connected monitors, provide a RS-232C/D compliant port (DB-9 female connector) on the front panel of the conflict monitor in order to provide communications from the conflict monitor to the 170/2070 controller or to a Department-furnished laptop computer. Electrically isolate the port interface electronics from all monitor electronics, excluding Chassis Ground. Ensure that the controller can receive all event log information through a controller

U-2729**TS-29****Forsyth County**

Asynchronous Communications Interface Adapter (Type 170E) or Async Serial Comm Module (2070). Furnish and connect a serial cable from the conflict monitor's DB-9 connector to Comm Port 1 of the 2070 controller. Ensure conflict monitor communicates with the controller. Provide a Windows based graphic user interface software to communicate directly through the same monitor RS-232C/D compliant port to retrieve and view all event log information to a Department-furnished laptop computer. The RS-232C/D compliant port on the monitor shall allow the monitor to function as a DCE device with pin connections as follows:

Conflict Monitor RS-232C/D (DB-9 Female) Pinout		
Pin Number	Function	I/O
1	DCD	O
2	TX Data	O
3	RX Data	I
4	DTR	I
5	Ground	-
6	DSR	O
7	CTS	I
8	RTS	O
9	NC	-

U-2729

TS-30

Forsyth County

MONITOR BOARD EDGE CONNECTOR

Pin #	Function (Back Side)	Pin #	Function (Component Side)
1	Channel 2 Green	A	Channel 2 Yellow
2	Channel 13 Green	B	Channel 6 Green
3	Channel 6 Yellow	C	Channel 15 Green
4	Channel 4 Green	D	Channel 4 Yellow
5	Channel 14 Green	E	Channel 8 Green
6	Channel 8 Yellow	F	Channel 16 Green
7	Channel 5 Green	H	Channel 5 Yellow
8	Channel 13 Yellow	J	Channel 1 Green
9	Channel 1 Yellow	K	Channel 15 Yellow
10	Channel 7 Green	L	Channel 7 Yellow
11	Channel 14 Yellow	M	Channel 3 Green
12	Channel 3 Yellow	N	Channel 16 Yellow
13	Channel 9 Green	P	Channel 17 Yellow
14	Channel 17 Green	R	Channel 10 Green
15	Channel 11 Yellow	S	Channel 11 Green
16	Channel 9 Yellow	T	Channel 18 Yellow
17	Channel 18 Green	U	Channel 10 Yellow
--		--	
18	Channel 12 Yellow	V	Channel 12 Green
19	Channel 17 Red	W	Channel 18 Red
20	Chassis Ground	X	Not Assigned
21	AC-	Y	DC Common
22	Watchdog Timer	Z	External Test Reset
23	+24VDC	AA	+24VDC
24	Tied to Pin 25	BB	Stop Time (Output)
25	Tied to Pin 24	CC	Not Assigned
26	Not Assigned	DD	Not Assigned
27	Relay Output, Side #3, N.O.	EE	Relay Output, Side #2, Common
28	Relay Output, Side #1, N.C.	FF	AC+

-- Slotted for keying between Pins 17/U and 18/V

U-2729

TS-31

Forsyth County

CONFLICT PROGRAM CARD PIN ASSIGNMENTS

Pin #	Function (Back Side)	Pin #	Function (Component Side)
1	Channel 2 Green	A	Channel 1 Green
2	Channel 3 Green	B	Channel 2 Green
3	Channel 4 Green	C	Channel 3 Green
4	Channel 5 Green	D	Channel 4 Green
5	Channel 6 Green	E	Channel 5 Green
6	Channel 7 Green	F	Channel 6 Green
7	Channel 8 Green	H	Channel 7 Green
8	Channel 9 Green	J	Channel 8 Green
9	Channel 10 Green	K	Channel 9 Green
10	Channel 11 Green	L	Channel 10 Green
11	Channel 12 Green	M	Channel 11 Green
12	Channel 13 Green	N	Channel 12 Green
13	Channel 14 Green	P	Channel 13 Green
14	Channel 15 Green	R	Channel 14 Green
15	Channel 16 Green	S	Channel 15 Green
16	N/C	T	PC AJAR
17	Channel 1 Yellow	U	Channel 9 Yellow
18	Channel 2 Yellow	V	Channel 10 Yellow
19	Channel 3 Yellow	W	Channel 11 Yellow
20	Channel 4 Yellow	X	Channel 12 Yellow
21	Channel 5 Yellow	Y	Channel 13 Yellow
22	Channel 6 Yellow	Z	Channel 14 Yellow
23	Channel 7 Yellow	AA	Channel 15 Yellow
24	Channel 8 Yellow	BB	Channel 16 Yellow
--		--	
25	Channel 17 Green	CC	Channel 17 Yellow
26	Channel 18 Green	DD	Channel 18 Yellow
27	Channel 16 Green	EE	PC AJAR (Program Card)
28	Yellow Inhibit Common	FF	Channel 17 Green

-- Slotted for keying between Pins 24/BB and 25/CC

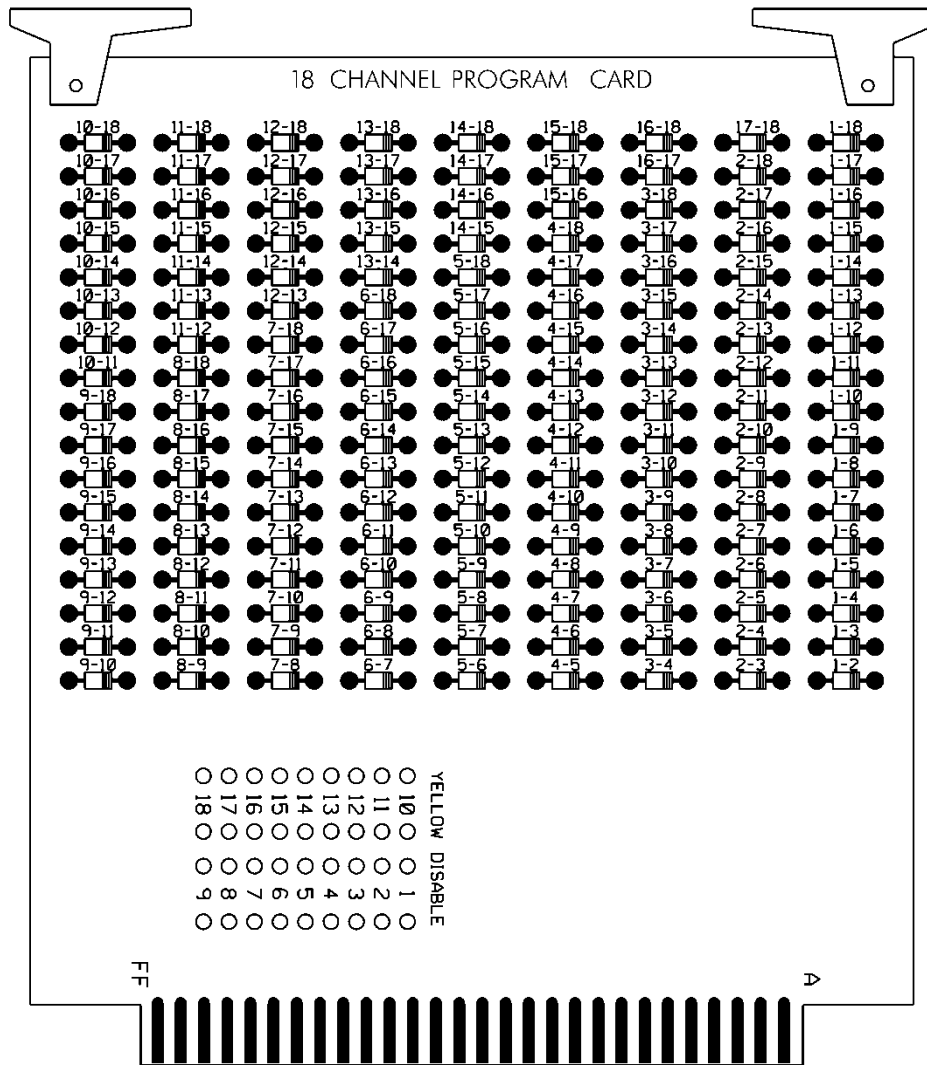

3.4. MATERIALS – TYPE 170 DETECTOR SENSOR UNITS

Furnish detector sensor units that comply with Chapter 5 Section 1, “General Requirements,” and Chapter 5 Section 2, “Model 222 & 224 Loop Detector Sensor Unit Requirements,” of the CALTRANS “Transportation Electrical Equipment Specifications” dated March 12, 2009 with Erratum 1.

4. VIDEO IMAGING LOOP EMULATOR DETECTOR SYSTEMS

4.1. DESCRIPTION

Design, furnish, provide training, and install video imaging loop emulator detection systems with all necessary hardware in accordance with the plans and specifications.

Unless otherwise specified in the contract, all loop emulator detection equipment will remain the property of the contractor.

4.2. MATERIALS

A. General:

Material and equipment furnished under this section must be pre-approved on the Department's QPL by the date of installation except miscellaneous hardware such as cables and mounting hardware do not need to be pre-approved.

Used equipment will be acceptable provided the following conditions have been met:

- Equipment is listed on the current QPL.
- Equipment is in good working condition.
- Equipment is to remain the property of the contractor.

Ensure that software is licensed for use by the Department and by any other agency responsible for maintaining or operating the loop emulation system. Provide the Department with a license to duplicate and distribute the software as necessary for design and maintenance support.

Design and furnish video imaging loop emulator detection systems that detect vehicles at signalized intersections by processing video images and providing detection outputs to the signal controller in real time (within 112 milliseconds of vehicle arrival).

Furnish all required camera sensor units, loop emulator processor units, hardware and software packages, cabling, poles, mast arms, harnesses, camera mounting assemblies, surge protection panels, grounding systems, messenger cable and all necessary hardware. Furnish systems that allow the display of detection zones superimposed on an image of the roadway on a Department-furnished monitor or laptop computer screen. Ensure detection zones can be defined and data entered using a simple keyboard or mouse and monitor, or using a laptop PC with software.

Provide design drawings showing design details and camera sensor unit locations for review and acceptance before installation. Provide mounting height and location requirements for camera sensor units on the design based on site survey. Design video imaging loop emulator detection systems with all necessary hardware. Indicate all necessary poles, spans, mast arms, luminaire arms, cables, camera mounting assemblies and hardware to achieve the required detection zones where Department owned poles are not adequate to locate the camera sensor units. Do not design for the installation of poles in medians.

Obtain the Engineer's approval before furnishing video imaging loop emulator detection systems. The contractor is responsible for the final design of video imaging loop emulator detection systems. Review and acceptance of the designs by the Department does not relieve the contractor from the responsibility to provide fully functional systems and to ensure that the required detection zones can be provided.

Provide the ability to program each detection call (input to the controller) with the following functions:

- Full Time Delay – Delay timer is active continuously,
- Normal Delay – Delay timer is inhibited when assigned phase is green (except when used with TS 2 and 170/2070L controllers),
- Extend – Call is extended for this amount of time after vehicle leaves detection area,
- Delay Call/Extend Call – This feature uses a combination of full time delay and extend time on the same detection call. Ensure operation is as follows: Vehicle calls are received after the delay timer times out. When a call is detected, it is held until the detection area is empty and the programmed extend time expires. If another vehicle enters the detection area before the

extend timer times out, the call is held and the extend time is reset. When the extend timer times out, the delay timer has to expire before another vehicle call can be received.

Provide the ability to program each detection zone as one of the following functions:

- Presence detector,
- Directional presence detector,
- Pulse detector,
- Directional pulse detector.

Ensure previously defined detector zones and configurations can be edited.

Provide each individual system with all the necessary equipment to focus and zoom the camera lenses without the need to enter the camera enclosure.

Provide systems that allow for the placement of at least 8 detection zones within the combined field of view of a single camera sensor unit. Provide a minimum of 8 detection outputs per camera.

Provide detection zones that can be overlapped. Ensure systems reliably detect vehicles when the horizontal distance from the camera sensor unit to the detection zone area is less than ten times the mounting height of the sensor. Ensure systems detect vehicles in multiple travel lanes.

Ensure systems can detect vehicle presence within a 98 to 102 percent accuracy (up to 2 percent of the vehicles missed and up to 2 percent of false detection) for clear, dry, daylight conditions, a 96 to 105 percent accuracy (up to 4 percent of the vehicles missed and up to 5 percent false detection) for dawn and dusk conditions, and a 96 percent accuracy (up to 4 percent of the vehicles missed) for night and adverse conditions (fog, snow, rain, etc.) using standard sensor optics and in the absence of occlusion.

Repair and replace all failed components within 72 hours.

The Department may conduct field-testing to ensure the accuracy of completed video imaging loop emulator detection systems.

B. Loop Emulator System:

Furnish loop emulator systems that receive and simultaneously process information from camera sensor units, and provides detector outputs to signal controllers.

Ensure systems provide the following:

- Operate in a typical roadside environment and meet the environmental specifications and are fully compatible with NEMA TS 1, NEMA TS 2, or Type 170/2070L controllers and cabinets,
- provide a “fail-safe” mode whereby failure of one or more of the camera sensor units or power failure of the loop emulator system will cause constant calls to be placed on the affected vehicle detection outputs to the signal controller,
- provide compensation for minor camera movement of up to 2 percent of the field of view at 400 feet without falsely detecting vehicles,
- process the video at a minimum rate of 30 times per second,
- provide separate wired connectors inside the controller cabinet for video recording each camera,
- provide remote video monitoring with a minimum refresh rate at 1 frame per second over a standard dial-up telephone line,
- provide remote video detection monitoring.

Furnish camera sensor units that comply with the following:

- have an output signal conforming to EIA RS-170 standard,
- have a nominal output impedance of 75 ohms,
- be immune to bright light sources, or have built in circuitry or protective devices to prevent damage to the sensor when pointed directly at strong light sources,
- be housed in a light colored environmental enclosure that is water proof and dust tight, and that conforms to NEMA-4 specifications or better,
- simultaneously monitor at least five travel lanes when placed at the proper mounting location with a zoom lens,
- have a sunshield attached to the environmental enclosure to minimize solar heating,
- meet FCC class B requirements for electromagnetic interference emissions,
- have a heater attached to the viewing window of the environmental enclosure to prevent ice and condensation in cold weather.

Where coaxial video cables and other cables are required between the camera sensor and other components located in the controller cabinet, furnish surge protection in the controller cabinet.

If furnishing coaxial communications cable comply with the following, as recommended by the approved loop emulator manufacturer:

- Number 20 AWG, solid bare copper conductor terminated with crimped-on BNC connectors (do not use BNC adapters) from the camera sensor to the signal controller cabinet.
- Number 22 AWG, stranded bare copper conductor terminated with crimped-on BNC connectors (do not use BNC adapters) from the camera sensor unit to the junction box, and within the signal controller cabinet.

Furnish power cable appropriately sized to meet the power requirements of the sensors. At a minimum, provide three conductor 120 VAC field power cable.

As determined during the site survey, furnish sensor junction boxes with nominal 6 x 10 x 6 inches dimensions at each sensor location. Provide terminal blocks and tie points for coaxial cable.

C. Video Imaging Loop Emulator System Support:

Furnish video imaging loop emulator systems with either a simple keyboard or a mouse with monitor and appropriate software, or with system software for use on department-owned laptop PCs. Ensure the system is Windows 2000 and Windows XP compatible.

Provide Windows 2000 and Windows XP compatible personal computer software, if needed, to provide remote video and video detection monitoring.

Ensure systems allow the user to edit previously defined detector configurations. When a vehicle is within a detection zone, provide for a change in color or intensity of the detection zone perimeter or other appropriate display changes on the Department-furnished monitor or laptop computer screen.

Provide cabling and interconnection hardware with 6-foot minimum length interconnection cable to interface with the system.

Provide all associated equipment manuals and documentation.

4.3. CONSTRUCTION METHODS

Arrange and conduct site surveys with the system manufacturer's representative and Department personnel to determine proper camera sensor unit selection and placement. Provide the Department

at least 3 working days notice before conducting site surveys. Upon completion of the site surveys the Department will provide revised plans reflecting the findings of the site survey.

Before beginning work at locations requiring video imaging loop emulator detection systems, furnish system software. Upon activation of detection zones, provide detector configuration files. Ensure that up-to-date detection configuration files are furnished for various detection zone configurations that may be required for construction phasing.

Place into operation loop emulator detection systems. Configure loop emulator detection systems to achieve required detection in designated zones. Have a certified manufacturer’s representative on site to supervise and assist with installation, set up, and testing of the system.

Install the necessary processing and communications equipment in the signal controller cabinet. Make all necessary modifications to install equipment, cabling harnesses, and camera sensor interface panels with surge suppression.

Perform modifications to camera sensor unit gain, sensitivity, and iris limits necessary to complete the installation.

Do not install camera sensor units on signal poles unless approved by the Engineer.

Install the necessary cables from each sensor to the signal controller cabinet along signal cabling routes. Install surge protection and terminate all cable conductors.

Reconfigure detection zones as necessary according to the plans for construction phases.

Provide at least 8 hours of training on the set up, operation, troubleshooting, and maintenance of the loop emulator detection system to a maximum of ten Department personnel. Arrange for training to be conducted by the manufacturer’s representative at an approved site within the Division responsible for administration of the project. Thirty days before conducting training submit a detailed course curriculum, draft manuals and materials, and resumes. Obtain approval of the submittal before conducting the training. At least one week before beginning training, provide three sets of complete documentation necessary to maintain and operate the system. Do not perform training until installation of loop emulator detection systems is complete.

4.4. MEASUREMENT AND PAYMENT

Actual number of site surveys, arranged, conducted, and accepted.

Actual number of luminaire arms for video systems furnished, installed, and accepted.

Actual number of cameras without internal loop emulator processing units furnished, installed, and accepted.

Actual number of external loop emulator processing units furnished, installed, and accepted.

No measurement will be made of video imaging loop emulator system support or training, power and video cables, and trenching as these items will be considered incidental to furnishing and installing video imaging loop emulator detection systems.

Payment will be made under:

Site Survey	Each
Luminaire Arm for Video System	Each
Camera without Internal Loop Emulator Processing Unit.....	Each
External Loop Emulator Processing Unit	Each

U-2729

TS-37

Forsyth County

5. METAL POLE SUPPORTS

5.1. METAL POLES

A. General:

Furnish and install metal poles, grounding systems, and all necessary hardware. Work covered under this special provision includes requirements for design, fabrication, and installation of standard and custom/site-specific designed metal pole supports and associated foundations.

Comply with applicable sections of the *2018 STANDARD SPECIFICATIONS FOR ROADS & STRUCTURES*, hereinafter referred to as the *Standard Specifications*. Provide designs of completed assemblies with hardware equaling or exceeding AASHTO *Standard Specifications for Structural Supports for Highway Signs, Luminaires and Traffic Signals* 6th Edition, 2013 (hereinafter called 6th Edition AASHTO), including the latest interim specifications. Provide assemblies with a round or near-round (18 sides or more) cross-section, or a multi-sided cross section with no less than six sides. The sides may be straight, convex, or concave.

For bid purposes, pole heights shown on plans are estimated from available data. Prior to furnishing metal poles, use field measurements and adjusted cross-sections to determine whether pole heights will meet required clearances. If pole heights do not meet required clearances, the Contractor should immediately notify the Engineer of the required revised pole heights.

Standard Drawings for Metal Poles are available that supplement these project special provisions. The drawings are located on the Department's website:

<https://connect.ncdot.gov/resources/safety/pages/ITS-Design-Resources.aspx>

Comply with article 1098-1B of the *Standard Specifications* for submittal requirements. Furnish shop drawings for approval. Provide copies of detailed shop drawings for each type of structure as summarized below. Ensure shop drawings include material specifications for each component. Ensure shop drawings identify welds by type and size on the detail drawing only, not in table format. **Do not release structures for fabrication until shop drawings have been approved by NCDOT.** Ensure shop drawings contain an itemized bill of materials for all structural components and associated connecting hardware.

Comply with article 1098-1A of the *Standard Specifications* for Qualified Products List (QPL) submittals. All shop drawings must include project location description, signal or asset inventory number(s) and project number or work order number.

Summary of information required for metal pole review submittal:

Item	Electronic Submittal	Comments / Special Instructions
Sealed, Approved Signal or ITS Plan/Loading Diagram	1 set	All structure design information needs to reflect the latest approved Signal or ITS plans
Custom Pole Shop Drawings	1 set	Submit drawings on 11" x 17" format media. Show NCDOT signal or asset inventory number(s), Contractor's name and relevant revision number in the title block. All drawings must have a <u>unique drawing number</u> for each project.
Standard Strain Pole Shop Drawings (from the QPL)	1 set	Submit drawings on 11" x 17" format media. Show NCDOT signal inventory number(s),

U-2729

TS-38

Forsyth County

		Contractor's name and relevant revision number in the title block. All drawings must have a <u>unique drawing number</u> for each project.
Structure Calculations	1 set	Not required for Standard QPL Poles
Standard Strain Pole Foundation Drawings	1 set	Submit drawings on 11" x 17" format media. Submit a completed Standard Foundation Selection form for each pole using foundation table on Metal Pole Drawing M8.
Custom Foundation Drawings	1 set	Submit drawings on 11" x 17" format media. Show NCDOT signal or asset inventory number(s), Contractor's name and relevant revision number in the title block. All drawings must have a <u>unique drawing number</u> for each project. If QPL Poles are used, include the corresponding QPL pole shop drawings with this submittal.
Foundation Calculations	1 set	Submit copies of LPILE input, output, and pile tip deflection graph per Section titled Drilled Pier Foundations for Metal Poles of this specification for each foundation. Not required for Standard Strain Poles (from the QPL)
Soil Boring Logs and Report	1 set	Report shall include a location plan and a soil classification report including soil capacity, water level, hammer efficiency, soil bearing pressure, soil density, etc. for each pole.

NOTE – All shop drawings and custom foundation design drawings must be sealed by a Professional Engineer licensed in the state of North Carolina. All geotechnical information must be sealed by either a Professional Engineer or Geologist licensed in the state of North Carolina. Include a title block and revision block on the shop drawings and foundation drawings showing the NCDOT signal or asset inventory number(s).

Shop drawings and foundation drawings may be submitted together or separately for approval. However, shop drawings must be approved before foundations can be reviewed. Foundation designs will be returned without review if the associated shop drawing has not been approved. Boring reports shall include the following: Engineer's summary, boring location maps, soil classification per AASHTO Classification System, hammer efficiency, and Metal Pole Standard Foundation Selection Form. Incomplete submittals will be returned without review. The Reviewer has the right to request additional analysis and copies of the calculations to expedite the approval process.

B. Materials:

Fabricate metal pole from coil or plate steel that meet the requirements of ASTM A 572 Gr 55 or ASTM A 595 Grade A tubes. For structural steel shapes, plates, and bars use, as a minimum, ASTM A572 Gr 50, AASHTO M270 Gr 50, ASTM A709 Gr 50, or an approved equivalent. Provide pole shafts of round or near round (18 sides or more) cross-section, or multi-sided tubular cross-section with no less than six sides, having a uniform linear taper of 0.14 in/ft. Construct shafts from one

piece of single-ply plate or coil. For anchor base fabrication, conform to the applicable bolt pattern and orientation as shown on Metal Pole Standard Drawing Sheet M2.

Use the submerged arc process, or other NCDOT previously approved process suitable for shafts, to continuously weld pole shafts along their entire length. Finish the longitudinal seam weld flush with the outside contour of the base metal. Ensure shaft has no circumferential welds except at the lower end joining the shaft to the pole base. Use full penetration groove welds with backing ring for all tube-to-transverse-plate connections in accordance with 6th Edition AASHTO. Provide welding that conforms to Article 1072-18 of the *Standard Specifications*. No field welding on any part of the pole will be permitted unless approved by a qualified Engineer.

After fabrication, hot-dip galvanize steel poles and all assembly components in accordance with section 1076-3 of the *Standard Specifications*. Design structural assemblies with weep holes large enough and properly located to drain molten zinc during the galvanization process. Galvanize hardware in accordance with section 1076-4 of the *Standard Specifications*. Ensure threaded material is brushed and retapped as necessary after galvanizing. Perform repair of damaged galvanizing in accordance with section 1076-7 of the *Standard Specifications*. Ensure all hardware is galvanized steel or stainless steel. The Contractor is responsible for ensuring the Designer/Fabricator specifies connecting hardware and/or materials that prevent a dissimilar metal corrosive reaction.

Ensure each anchor rod is 2-inch minimum diameter and 60-inch length. Provide 10-inch minimum thread projection at the top of the rod, and 8-inch minimum at the bottom of the rod. Use anchor rod assembly and drilled pier foundation materials complying with SP09_R005, hereinafter referred to as *Foundations and Anchor Rod Assemblies for Metal Poles*.

Ensure anchor bolt hole diameters are ¼-inch larger than the anchor bolt diameters in the base plate.

Provide a circular anchor bolt lock plate securing the anchor bolts at the embedded end with two (2) washers and two (2) nuts. Provide a base plate template matching the bolt circle diameter of the anchor bolt lock plate. Construct plates and templates from ¼-inch minimum thick steel with a minimum width of 4 inches. Hot-dip galvanizing is not required for both plates.

Provide four (4) heavy hex nuts and four (4) flat washers for each anchor bolt. For nuts, use AASHTO M291 grade 2H, DH, or DH3 or equivalent material. For flat washers, use AASHTO M293 or equivalent material. Ensure anchor bolts have required diameters, lengths, and positions, and will develop strengths comparable to their respective poles.

For each pole, provide a grounding lug with a ½-inch minimum thread diameter, coarse thread stud and nut that will accommodate #4 AWG ground wire. Ensure the lug is electrically bonded to the pole and is conveniently located inside the pole at the hand hole.

Provide a removable pole cap with stainless steel attachment screws for the top of each pole. Ensure cap is cast aluminum conforming to Aluminum Association Alloy 356.0F. Furnish cap attached to the pole with a sturdy stainless-steel chain that is long enough to permit cap to hang clear of the pole-top opening when cap is removed.

Where required by the plans, furnish couplings 42 inches above bottom of the pole base for mounting of pedestrian pushbuttons. Provide mounting points consisting of 1½-inch internally threaded half-couplings complying with the NEC, mounted within the poles. Ensure that couplings are essentially flush with the outside surfaces of the poles and are installed before any required hot-dip galvanizing. Provide a threaded plug in each mounting point. Ensure the surface of the plug is

essentially flush with the outer end of the mounting point when installed and has a recessed slot that will accommodate a ½ “drive standard socket wrench.

Metal poles may be erected and fully loaded after concrete has attained a minimum allowable compressive strength of 3,000 psi.

Connect poles to grounding electrodes and bond them to the electrical service grounding electrodes.

When field drilling is necessary for wire or cable entrances into the pole, comply with the following requirements:

- Do not drill holes within 2 inches of any welds.
- Do not drill any holes larger than 3 inches in diameter without checking with the ITS & Signals Structure Engineers.
- Avoid drilling multiple holes along the same cross section of tube shafts.
- Install rubber grommets in all field drilled holes that wire, or cable will directly enter unless holes are drilled for installation of weather heads or couplings.
- Treat the inside of the drilled holes and repair all galvanized surfaces in accordance with Section 1076-7 of the latest edition of the *Standard Specification prior to installing grommets, caps, or plugs*.
- Cap or plug any existing field drilled holes that are no longer used with rubber, aluminum, or stainless-steel hole plugs.

When street lighting is installed on metal signal structures, isolate the conductors feeding the luminaires inside the pole shaft using liquid tight flexible metal conduit (Type LFMC), liquid tight flexible nonmetallic conduit (Type LFNC), high density polyethylene conduit (Type HDPE), or approved equivalent. All conductors supplying power for luminaires must run through an external disconnect prior to entrance into the structure. Comply with applicable National Electrical Safety Codes (NESC). Refer to Article “G” Luminaire Arms.

Install a ¼-inch thick plate for a concrete foundation tag to include the following information: concrete grade, depth, diameter, and reinforcement sizes of the installed foundation. Install galvanized wire mesh to cover gap between the base plate and top of foundation for debris and pest control. Refer to standard drawing M7 for further details.

Immediately notify the Engineer of any structural deficiency that becomes apparent in any assembly, or member of any assembly, because of the design requirements imposed by these specifications, the plans, or the typical drawings.

C. Design:

Unless otherwise specified, design all metal pole support structures using the following 6th Edition AASHTO specifications:

- Design for a 50-year service life as recommended by Table 3.8.3-2.
- Use wind pressure map developed from 3-second gust speeds, as provided in Section 3.8.
- Assume wind loads as shown in Figures 3.9.4.2-2 and 3.9.4.2-3 of the 6th Edition AASHTO for Group III loading with Ice.
- Ensure metal pole support structures include natural wind gust loading and truck-induced gust loading for fatigue design, as provided in Sections 11.7.1.2 and 11.7.1.3, respectively. Designs need not consider periodic galloping forces.

- Assume 11.2 mph natural wind gust speed in North Carolina. For natural wind fatigue stress calculations, utilize a drag coefficient (C_d) based on the yearly mean wind velocity of 11.2 mph.
- When selecting Fatigue Importance Factors, utilize Fatigue Importance Category II, as provided for in Table 11.6-1, unless otherwise specified.
- Calculate all stresses using applicable equations from Section 5. The Maximum allowable stress ratio for all metal pole support designs is 0.9.
- Conform to Sections 10.4.2 and 11.8 for deflection requirements. For CCTV and MVD support structures, ensure maximum deflection at top of pole does not exceed 2.0 percent of pole height.
- Assume the combined minimum weight of a messenger cable bundle (including messenger cable, signal cable and detector lead-in cables) is 1.3 lbs/ft. Assume the combined minimum diameter of the cable bundle is 1.3 inches.
- All CCTV and MVD poles shall meet the compact section limits per section 5.5.2 along with Table 5.5.2-1. Minimum thickness of CCTV and MVD pole shafts shall be ¼-inch.
- All CCTV and MVD poles shall use full-penetration groove weld tube-to-transverse plate connection with backing ring. Refer to Metal Pole Standard Drawing Sheet M9 for details. Fillet-welded tube-to-transverse-plate connections are not permitted.

Unless otherwise specified by special loading criteria, the following computed surface area for ice load on signal heads shall be used:

- 3-section, 12-inch, Surface area: 26.0 ft²
- 4-section, 12-inch, Surface area: 32.0 ft²
- 5-section, 12-inch, Surface area: 42.0 ft²

Design a base plate for each pole. The minimum base plate thickness for all poles is determined by the following criteria:

Case 1 Circular or rectangular solid base plate with the upright pole welded to the top surface of base plate with full penetration butt weld, where no stiffeners are provided. A base plate with a small center hole, which is less than 1/3 of the upright diameter, and located concentrically with the upright pole, may be considered as a solid base plate.

The magnitude of bending moment in the base plate, induced by the anchoring force of each anchor bolt is $M = (P \times D_1) / 2$, where

M = bending moment at the critical section of the base plate induced by one (1) anchor bolt

P = anchoring force of each anchor bolt

D_1 = horizontal distance between the anchor bolt center and the outer face of the upright, or the difference between the bolt circle radius and the outside radius of the upright

Locate the critical section at the face of the anchor bolt and perpendicular to the bolt circle radius. The overlapped part of two (2) adjacent critical sections is considered ineffective.

Case 2 Circular or rectangular base plate with the upright pole socketed into and attached to the base plate with two (2) lines of fillet weld, and where no stiffeners are provided, or any base plate with a center hole that is larger in diameter than 1/3 of the upright diameter.

The magnitude of bending moment induced by the anchoring force of each anchor bolt is $M = P \times D_2$,

where P = anchoring force of each anchor bolt

D_2 = horizontal distance between the face of the upright and the face of the anchor bolt nut

Locate the critical section at the face of the anchor bolt top nut and perpendicular to the radius of the bolt circle. The overlapped part of two (2) adjacent critical sections is considered ineffective. If the base plate thickness calculated for Case 2 is less than Case 1, use the thickness calculated for Case 1.

The following additional requirements apply concerning pole base plates.

- Ensure that whichever case governs as defined above, the anchor bolt diameter is set to match the base plate thickness. If the minimum diameter required for the anchor bolt exceeds the thickness required for the base plate, set the base plate thickness equal to the required bolt diameter.
- For all metal poles, use a full penetration groove weld with a backing ring to connect the pole upright component to the base. Refer to Metal Pole Standard Drawing Sheet M3 or M4.

The Professional Engineer is wholly responsible for the design of all poles. Review and acceptance of these designs by the Department does not relieve the said Professional Engineer of his or her responsibility.

D. Strain Poles:

Refer to Metal Pole Standard Drawing Sheets M2 and M3 for fabrication details.

Provide two (2) messenger cable (span wire) clamps and associated hardware for attachment of messenger cable. Ensure diameter of the clamp is appropriate to its location on the pole and is appropriately designed for adjustment from 1'-6" below the top, down to 6'-6" below the top of the pole. Do not attach more than one (1) support cable to a messenger cable clamp.

Provide a minimum of three (3) 2-inch holes equipped with an associated coupling and weatherhead on the messenger cable load side of the pole to accommodate passage of signal cables from inside the pole. Provide galvanized threaded plugs for all unused couplings at pole entrance points. Refer to Metal Pole Standard Drawing Sheet M3 for fabrication details.

Provide designs with a 6" x 12" hand hole with reinforcing frame for each pole.

Provide a terminal compartment with cover and screws in each pole encompassing the hand hole and containing a 12-terminal barrier type terminal block. Provide two (2) terminal screws with a removable shorting bar between them for each termination. Furnish terminal compartment covers attached to the pole by a sturdy chain or cable approved by the Engineer. Ensure chain or cable is long enough to permit cover to hang clear of the compartment opening when cover is removed and is strong enough to prevent vandalism. Ensure chain or cable will not interfere with service to cables in the pole base.

Have poles permanently stamped above the hand holes with the identification tag details as shown on Metal Pole Standard Drawing Sheets M2 and M3.

Provide grounding lug(s) in the approximate vicinity of the messenger cable clamp for bonding and grounding messenger cable. Lugs must accept #4 AWG wire to bond messenger cables to the pole in order to provide an effective ground fault circuit path. Refer to Metal Pole Standard Drawing Sheet M6 for construction details.

Install metal poles, hardware, and fittings as shown on the manufacturer's installation drawings. Ensure the installed pole, when fully loaded, is within 1 degree 40 minutes (1°40') of vertical. Install poles with the manufacturer's recommended "rake." Where required, use threaded leveling nuts to establish rake.

5.2. DRILLED PIER FOUNDATIONS FOR METAL POLES

Analysis procedures and formulas shall be based on AASHTO 6th Edition, latest ACI-318 code and the *Drilled Shafts: Construction Procedures and Design Methods* FHWA-NHI-10-016 manual. Design methods based on engineering publications or research papers must have prior approval from NCDOT. The Department reserves the right to accept or reject any method used for the analysis.

Use the following Safety Factors for the foundation design:

- 1.0 x Service (Unfactored) Loads for L-Pile Shaft Lateral Deflection
- 1.3 x Torsion (Unfactored) Load for Drilled Shaft Concrete and Steel Strength
- (1.3 / 1.33) x Torsion (Unfactored) Load for Shaft Soil-to-Concrete Torsion Capacity
- (2.0 / 1.33) x Axial (Unfactored) Load for Shaft Axial Capacity in Soil

Ensure deflection at top of foundation does not exceed 1 inch for worst-case lateral load.

Use LPILE Plus V6.0 or later for lateral analysis. Submit inputs, results and corresponding graphs with the design calculations.

Calculate skin friction using the α -method for cohesive soils and the β -method for cohesion-less soils (**Broms method will not be accepted**). Detailed descriptions of the " α " and " β " methods can be found in *FHWA-NHI-10-016*.

Omit first 2.5 feet for cohesive soils when calculating skin friction.

Assume a hammer efficiency of 0.70 unless value is provided.

All CCTV and MVD pole drilled shafts shall be a minimum of 4'-0" diameter. Refer to Standard Drawing Nos. M7 and M8.

Design custom foundations to carry maximum capacity of each metal pole. For standard case strain poles with custom design, use actual shear, axial and moment reactions from the Standard Strain Pole Foundation Selection Table shown on Standard Drawing No. M8.

When poor soil conditions are encountered, which could create an excessively large foundation design, consideration may be given to allow an exemption to the maximum capacity design. The Contractor must gain approval from the Engineer before reducing a foundation's capacity. On projects where poor soil is known to be present, the Contractor should have foundation designs approved before releasing poles for fabrication.

Have the Contractor notify the Engineer if the proposed foundation is to be installed on a slope other than 8H: 1V or flatter.

A. Description:

Furnish and install foundations for NCDOT metal poles with all necessary hardware in accordance with the plans and specifications.

Metal Pole Standards have been developed and implemented by NCDOT for use at signalized intersections in North Carolina. If the plans call for a standard strain pole, then a standard foundation may be selected from the plans. However, the Contractor is not required to use a standard foundation. If the Contractor chooses to design a non-standard site-specific foundation for a standard strain pole or if the plans call for a non-standard site-specific pole, design the foundation to conform to the applicable provisions in the NCDOT Metal Pole Standard Drawings and Section

B4 (Non-Standard Foundation Design) below. If non-standard site-specific foundations are designed for standard QPL approved strain poles, the foundation designer must use the design moment specified by load case on Metal Pole Standard Drawing Sheet M8. Failure to conform to this requirement will be grounds for rejection of the design.

If the Contractor chooses to design a non-standard foundation for a standard strain pole and the soil test results indicate a standard foundation is feasible for the site, the Contractor will be paid the cost of the standard foundation. Any additional cost associated with a non-standard site-specific foundation including additional materials, labor and equipment will be considered incidental to the cost of the standard foundation. All costs for the non-standard foundation design will be considered incidental to the cost of the standard foundation.

B. Soil Test and Foundation Determination:

1. General:

Drilled piers are reinforced concrete sections, cast-in-place against in situ, undisturbed material. Drilled piers are of straight shaft type and vertical.

2. Soil Test:

Perform a soil test at each proposed metal pole location. Complete all required fill placement and excavation at each pole location to finished grade before drilling each boring. Soil tests performed that are not in compliance with this requirement may be rejected and will not be paid. Drill one boring to a depth of 26 feet within a 25-foot radius of each proposed foundation.

Perform standard penetration tests (SPT) in accordance with ASTM D 1586 at depths of 1, 2.5, 5, 7.5, 10, 15, 20 and 26 feet. Discontinue the boring if one of the following occurs:

- A total of 100 blows have been applied in any two consecutive 6-inch intervals.
- A total of 50 blows have been applied with < 3-inch penetration.

Describe each pole location along the project corridor in a manner that is easily discernible to both the Contractor's Designer and NCDOT Reviewers. If the pole is at an intersection, label the boring the "Intersection of (*Route or SR #*), (*Street Name*) and (*Route or SR #*), (*Street Name*), _____ County, Signal or Asset Inventory No. _____". Label borings with "B- *N, S, E, W, NE, NW, SE or SW*" corresponding to the quadrant location within the intersection.

If the pole location is located between intersections, provide a coordinate location and offset, or milepost number and offset. Pole numbers should be made available to the Drill Contractor. Include pole numbers in the boring label if they are available. If they are not available, ensure the boring labels can be cross-referenced to corresponding pole numbers. For each boring, submit a legible (hand-written or typed) boring log signed and sealed by a licensed Geologist or Professional Engineer registered in North Carolina. Include on each boring the SPT blow counts and N-values at each depth, depth of the boring, hammer efficiency, depth of water table and a general description of the soil types encountered using the AASHTO Classification System.

Borings that cannot be easily correlated to their specific pole location will be returned to the Contractor for clarification; or if approved by the Engineer, the foundation may be designed using the worst-case soil condition obtained as part of this project.

3. Standard Foundation Determination:

Use the following method for determining the Design N-value:

$$N_{AVG} = \frac{N_{@1'} + N_{@2.5'} + \dots + N_{@Deepest\ Boring\ Dept}}{Total\ Number\ of\ N\ values}$$

U-2729

TS-45

Forsyth County

$$Y = (N_{@1'})^2 + (N_{@2.5'})^2 + \dots + (N_{@Deepest\ Boring\ Depth})^2$$

$$Z = N_{@1'} + N_{@2.5'} + \dots + N_{@Deepest\ Boring\ Depth}$$

$$N_{STD\ DEV} = \sqrt{\left(\frac{(Total\ Number\ of\ N\ values \times Y) - Z^2}{(Total\ Number\ of\ N\ values) \times (Total\ Number\ of\ N\ values - 1)} \right)}$$

Design N-value equals lesser of the following two conditions:

$$N_{AVG} - (N_{STD\ DEV} \times 0.45)$$

OR

$$Average\ of\ First\ Four\ (4)\ N\ values = \frac{N_{@1'} + N_{@2.5'} + N_{@5'} + N_{@7.5'}}{4}$$

Note: If less than four (4) N-values are obtained because of criteria listed in Section 2 above, use average of N-values collected for second condition. Do not include the N-value at the deepest boring depth for above calculations if the boring is discontinued at or before the required boring depth because of criteria listed in Section 2 above. Use N-value of zero (0) for weight of hammer or weight of rod. If N-value is greater than fifty (50), reduce N-value to fifty (50) for calculations.

If standard NCDOT strain poles are shown on the plans and the Contractor chooses to use standard foundations, determine a drilled pier length, "L," for each signal pole from the Standard Strain Pole Foundations Chart (sheet M8) based on the Design N-value and the predominant soil type. For each standard pole location, submit a completed "Metal Pole Standard Foundation Selection Form" signed by the Contractor's representative. Signature on form is for verification purposes only. Include the Design N-value calculation and resulting drilled pier length, "L," on each form.

If non-standard site-specific poles are shown on the plans, submit completed boring logs collected in accordance with Section 2 (Soil Test) along with pole loading diagrams from the plans to the Contractor-selected pole Fabricator to assist in the pole and foundation design.

If one of the following occurs, the Standard Foundations Chart shown on the plans may not be used and a non-standard foundation may be required. In such case, contact the Engineer.

- The Design N-value is less than four (4).
- The drilled pier length, "L", determined from the Standard Foundations Chart, is greater than the depth of the corresponding boring.

In the case where a standard foundation cannot be used, the Department will be responsible for the additional cost of the non-standard foundation.

Foundation designs are based on level ground around the traffic signal pole. If the slope around the edge of the drilled pier is steeper than 8:1 (H:V) or the proposed foundation will be less than 10

feet from the top of an embankment slope, the Contractor is responsible for providing slope information to the foundation Designer and to the Engineer so it can be considered in the design.

The “Metal Pole Standard Foundation Selection Form” may be found at:

<https://connect.ncdot.gov/resources/safety/Pages/ITS-Design-Resources.aspx>

If assistance is needed, contact the Engineer.

4. Non-Standard Foundation Design:

Design non-standard foundations based upon site-specific soil test information collected in accordance with Section 2 (Soil Test). Design drilled piers for side resistance in accordance with Section 4.6 of the 2002 AASHTO Standard Specifications for Highway Bridges, 17th Edition. Use computer software LPILE version-6.0 or later manufactured by Ensoft, Inc. to analyze drilled piers. Use computer software gINT V8i or later manufactured by Bentley Systems, Inc. with the current NCDOT gINT library and data template to produce SPT boring logs. Provide a drilled pier foundation for each pole with a length and diameter resulting in horizontal lateral movement less than 1 inch at top of the pier, and horizontal rotational movement less than 1 inch at the edge of pier. Contact the Engineer for pole loading diagrams of standard poles used for non-standard foundation designs. Submit non-standard foundation designs including drawings, calculations, and soil boring logs to the Engineer for review and approval before construction.

C. Drilled Pier Construction:

Construct drilled pier foundation and Install anchor rod assemblies in accordance with the Foundations and Anchor Rod Assemblies for Metal Poles Standard Special Provision SP09-R005 located at:

<https://connect.ncdot.gov/resources/Specifications/Pages/2018-Specifications-and-Special-Provisions.aspx>

5.3. POLE NUMBERING SYSTEM

Attach an identification tag to each pole shaft section as shown on Metal Pole Standard Sheet M2 “Typical Fabrication Details for All Metal Poles.”

5.4. MEASUREMENT AND PAYMENT

Actual number of metal strain signal poles (without regard to height or load capacity) furnished, installed and accepted.

Actual number of soil tests with SPT borings drilled furnished and accepted.

Actual volume of concrete poured in cubic yards of drilled pier foundation furnished, installed and accepted.

No measurement will be made for foundation designs prepared with metal pole designs, as these will be considered incidental to designing Traffic Signal , CCTV or MVD support structures.

Payment will be made under:

Metal Strain Signal Pole	Each
Soil Test	Each
Drilled Pier Foundation.....	Cubic Yard

6. BACK PULL FIBER OPTIC CABLE

6.1. DESCRIPTION

Back pull and store or back pull and reinstall existing communications cable.

6.2.CONSTRUCTION

During project construction where instructed to back pull existing aerial sections of fiber optic communications cable, de-lash the cable from the messenger cable and back pull the cable to a point where it can be stored or re-routed as shown on the plans. If instructed, remove and discard the existing messenger cable and pole mounting hardware once the fiber optic cable is safely out of harm’s way.

During project construction where instructed to back pull existing underground sections of fiber optic communications cable, back pull the cable to a point where it can be stored or re-routed as shown on the plans. If instructed, remove abandoned junction boxes and backfill with a suitable material to match the existing grade. Leave abandoned conduits in place unless otherwise noted.

Where instructed, re-pull the fiber optic cable back along messenger cable or through conduit systems.

6.3.MEASUREMENT AND PAYMENT

Back Pull Fiber Optic Cable will be paid for as the actual linear feet of fiber optic cable back pulled and stored or back pulled and rerouted. Payment is for the actual linear feet of cable back pulled.

No payment will be made for removing messenger cable and pole mounting hardware or removing junction boxes and back filling to match the surrounding grade as these items of work will be considered incidental to back pulling the fiber optic cable.

Payment will be made under:

Back Pull Fiber Optic Cable Linear Feet

7. ETHERNET EDGE SWITCH

Furnish and install a managed Ethernet edge switch as specified below that is fully compatible, interoperable, and completely interchangeable and functional within the existing City, Division, or Statewide traffic signal system communications network.

7.1. DESCRIPTION

A. Ethernet Edge Switch:

Furnish and install a hardened, field Ethernet edge switch (hereafter “edge switch”) for the traffic signal controller or ITS device as specified below. Ensure that the edge switch provides wire-speed, fast Ethernet connectivity at transmission rates of 1000 megabits per second from each remote traffic signal controller or ITS device location to the routing switches.

Contact the City or NCDIT to arrange for the programming of the new Field Ethernet Switches with the necessary network configuration data, including but not limited to, the IP Address, Default Gateway, Subnet Mask and VLAN ID information. Provide a minimum ten (10) working days notice to allow the City or NCDIT to program the new devices.

B. Network Management:

Ensure that the edge switch is fully compatible with the existing City, Division, or Statewide Network Management Software.

7.2. MATERIALS**A. General:**

Ensure that the edge switch is fully compatible and interoperable with the trunk Ethernet network interface and that the edge switch supports half and full duplex Ethernet communications.

Furnish an edge switch that provide 99.999% error-free operation, and that complies with the Electronic Industries Alliance (EIA) Ethernet data communication requirements using single-mode fiber-optic transmission medium and copper transmission medium. Ensure that the edge switch has a minimum mean time between failures (MTBF) of 10 years, or 87,600 hours, as calculated using the Bellcore/Telcordia SR-332 standard for reliability prediction.

B. Compatibility Acceptance

The Engineer has the authority to require the Contractor to submit a sample Field Ethernet Switch and SFP along with all supporting documentation, software and testing procedures to allow a compatibility acceptance test be performed prior to approving the proposed Field Ethernet Switch and Field Ethernet Transceiver for deployment. **The Compatibility Acceptance testing will ensure that the proposed device is 100% compatible and interoperable with the existing City, Division, or Statewide Signal System network, monitoring software and Traffic Operations Center network hardware.** Allow fifteen (15) working days for the Compatibility Acceptance Testing to be performed

C. Standards:

Ensure that the edge switch complies with all applicable IEEE networking standards for Ethernet communications, including but not limited to:

- IEEE 802.1D standard for media access control (MAC) bridges used with the Spanning Tree Protocol (STP);
- IEEE 802.1Q standard for port-based virtual local area networks (VLANs);
- IEEE 802.1P standard for Quality of Service (QoS);
- IEEE 802.1w standard for MAC bridges used with the Rapid Spanning Tree Protocol (RSTP);
- IEEE 802.1s standard for MAC bridges used with the Multiple Spanning Tree Protocol;
- IEEE 802.1x standard for port based network access control, including RADIUS;
- IEEE 802.3 standard for local area network (LAN) and metropolitan area network (MAN) access and physical layer specifications;
- IEEE 802.3u supplement standard regarding 100 Base TX/100 Base FX;
- IEEE 802.3x standard regarding flow control with full duplex operation; and
- IFC 2236 regarding IGMP v2 compliance.
- IEEE 802.1AB Link Layer Discovery Protocol (LLDP)
- IEEE 802.3ad Ethernet Link Aggregation
- IEEE 802.3i for 10BASE-T (10 Mbit/s over Fiber-Optic)
- IEEE 802.3ab for 1000BASE-T (1Gbit/s over Ethernet)
- IEEE 802.3z for 1000BASE-X (1 Gbit/s Ethernet over Fiber-Optic)

D. Functional:

Ensure that the edge switch supports all Layer 2 management features and certain Layer 3 features related to multicast data transmission and routing. These features shall include, but not be limited to:

- An STP healing/convergence rate that meets or exceeds specifications published in the IEEE 802.1D standard.
- An RSTP healing/convergence rate that meets or exceeds specifications published in the IEEE 802.1w standard.
- An Ethernet edge switch that is a port-based VLAN and supports VLAN tagging that meets or exceeds specifications as published in the IEEE 802.1Q standard, and has a minimum 4-kilobit VLAN address table (254 simultaneous).
- A forwarding/filtering rate that is a minimum of 14,880 packets per second for 10 megabits per second and 148,800 packets per second for 100 megabits per second.
- A minimum 4-kilobit MAC address table.
- Support of Traffic Class Expediting and Dynamic Multicast Filtering.
- Support of, at a minimum, snooping of Version 2 & 3 of the Internet Group Management Protocol (IGMP).
- Support of remote and local setup and management via telnet or secure Web-based GUI and command line interfaces.
- Support of the Simple Network Management Protocol version 3 (SNMPv3). Verify that the Ethernet edge switch can be accessed using the resident EIA-232 management port, a telecommunication network, or the Trivial File Transfer Protocol (TFTP).
- Port security through controlling access by the users. Ensure that the Ethernet edge switch has the capability to generate an alarm and shut down ports when an unauthorized user accesses the network.
- Support of remote monitoring (RMON-1 & RMON-2) of the Ethernet agent.
- Support of the TFTP and SNTP. Ensure that the Ethernet edge switch supports port mirroring for troubleshooting purposes when combined with a network analyzer.

E. Physical Features:

Ports: Provide 10/100/1000 Mbps auto-negotiating ports (RJ-45) copper Fast Ethernet ports for all edge switches. Provide auto-negotiation circuitry that will automatically negotiate the highest possible data rate and duplex operation possible with attached devices supporting the IEEE 802.3 Clause 28 auto-negotiation standard.

Optical Ports: Ensure that all fiber-optic link ports operate at 1310 or 1550 nanometers in single mode. Provide Type LC connectors for the optical ports, as specified in the Plans or by the Engineer. Do not use mechanical transfer registered jack (MTRJ) type connectors.

Provide an edge switch having a minimum of two optical 100/1000 Base X ports capable of transmitting data at 100/1000 megabits per second. Ensure that each optical port consists of a pair of fibers; one fiber will transmit (TX) data and one fiber will receive (RX) data. Ensure that the optical ports have an optical power budget of at least 15 dB. Provide small form-factor pluggable modules (SFPs) with a maximum range that meets or exceeds the distance requirement as indicated on the Plans.

Copper Ports: Provide an edge switch that includes a minimum of four copper ports. Provide Type RJ-45 copper ports and that auto-negotiate speed (i.e., 10/100/1000 Base) and duplex (i.e., full

or half). Ensure that all 10/100/1000 Base TX ports meet the specifications detailed in this section and are compliant with the IEEE 802.3 standard pinouts. Ensure that all Category 6 unshielded twisted pair/shielded twisted pair network cables are compliant with the EIA/TIA-568-B standard.

Port Security: Ensure that the edge switch supports/complies with the following (remotely) minimum requirements:

- Ability to configure static MAC addresses access;
- Ability to disable automatic address learning per ports; know hereafter as Secure Port. Secure Ports only forward; and
- Trap and alarm upon any unauthorized MAC address and shutdown for programmable duration. Port shutdown requires administrator to manually reset the port before communications are allowed.

F. Management Capabilities:

Ensure that the edge switch supports all Layer 2 management features and certain Layer 3 features related to multicast data transmission and routing. These features shall include, but not be limited to:

- An STP healing/convergence rate that meets or exceeds specifications published in the IEEE 802.1 D standards;
- An RSTP healing/convergence rate that meets or exceeds specifications published in the IEEE 802.1w standard;
- An Ethernet edge switch that is a port-based VLAN and supports VLAN tagging that meets or exceeds specifications as published in the IEEE 802.1Q standard, and has a minimum 4-kilobit VLAN address table (254 simultaneous);
- A forwarding/filtering rate that is a minimum of 14,880 packets per second for 10 megabits per second, 148,800 packets per second for 100 megabits per second and 1,488,000 packets per second for 1000 megabits per second;
- A minimum 4-kilobit MAC address table;
- Support of Traffic Class Expediting and Dynamic Multicast Filtering.
- Support of, at a minimum, snooping of Version 2 & 3 of the Internet Group Management Protocol (IGMP);
- Support of remote and local setup and management via telnet or secure Web-based GUI and command line interfaces; and
- Support of the Simple Network Management Protocol (SNMP). Verify that the Ethernet edge switch can be accessed using the resident EIA-232 management port, a telecommunication network, or the Trivial File Transfer Protocol (TFTP).

Network Capabilities: Provide an edge switch that supports/complies with the following minimum requirements:

- Provide full implementation of IGMPv2 snooping (RFC 2236);
- Provide full implementation of SNMPv1, SNMPv2c, and/or SNMPv3;
- Provide support for the following RMON–I groups, at a minimum:
 - Part 1: Statistics
 - Part 2: History
 - Part 3: Alarm
 - Part 9: Event
- Provide support for the following RMON–2 groups, at a minimum:

- Part 13: Address Map
- Part 17: Layer Matrix
- Part 16: Layer Host
- Part 18: User History

- Capable of mirroring any port to any other port within the switch;
- Meet the IEEE 802.1Q (VLAN) standard per port for up to four VLANs;
- Meet the IEEE 802.3ad (Port Trunking) standard for a minimum of two groups of four ports;
- Password manageable;
- Telnet/CLI;
- HTTP (Embedded Web Server) with Secure Sockets Layer (SSL); and
- Full implementation of RFC 783 (TFTP) to allow remote firmware upgrades.

Network Security: Provide an edge switch that supports/complies with the following (remotely) minimum network security requirements:

- Multi-level user passwords;
- RADIUS centralized password management (IEEE 802.1X);
- SNMPv3 encrypted authentication and access security;
- Port security through controlling access by the users: ensure that the Ethernet edge switch has the capability to generate an alarm and shut down ports when an unauthorized user accesses the network;
- Support of remote monitoring (RMON-1&2) of the Ethernet agent; and
- Support of the TFTP and SNTP. Ensure that the Ethernet edge switch supports port mirroring for troubleshooting purposes when combined with a network analyzer.

G. Electrical Specifications:

Ensure that the edge switch operates and power is supplied with 115 volts of alternating current (VAC). Ensure that the edge switch has a minimum operating input of 110 VAC and a maximum operating input of 130 VAC. Ensure that if the device requires operating voltages other than 120 VAC, supply the required voltage converter. Ensure that the maximum power consumption does not exceed 50 watts. Ensure that the edge switch has diagnostic light emitting diodes (LEDs), including link, TX, RX, speed (for Category 6 ports only), and power LEDs.

H. Environmental Specifications:

Ensure that the edge switch performs all of the required functions during and after being subjected to an ambient operating temperature range of -30 degrees to 165 degrees Fahrenheit as defined in the environmental requirements section of the NEMA TS 2 standard, with a noncondensing humidity of 0 to 95%.

Provide certification that the device has successfully completed environmental testing as defined in the environmental requirements section of the NEMA TS 2 standard. Provide certification that the device meets the vibration and shock resistance requirements of Sections 2.1.9 and 2.1.10, respectively, of the NEMA TS 2 standard. Ensure that the edge switch is protected from rain, dust, corrosive elements, and typical conditions found in a roadside environment.

The edge switch shall meet or exceed the following environmental standards:

- IEEE 1613 (electric utility substations)
- IEC 61850-3 (electric utility substations)
- IEEE 61800-3 (variable speed drive systems)

- IEC 61000-6-2 (generic industrial)
- EMF – FCC Part 15 CISPR (EN5502) Class A

I. Ethernet Patch Cable:

Furnish a factory pre-terminated/pre-connectorized Ethernet patch cable with each edge switch. Furnish Ethernet patch cables meeting the following physical requirements:

- Five (5)-foot length
- Category 6 or better
- Factory-installed RJ-45 connectors on both ends
- Molded anti-snag hoods over connectors
- Gold plated connectors
- Copper-clad aluminum is **NOT** allowed.

Furnish Fast Ethernet patch cords meeting the following minimum performance requirements:

- TIA/EIA-568-B-5, Additional Transmission Performance Specifications for 4-pair 100 Ω Enhanced Category 6 Cabling
- Frequency Range: 1-100 MHz
- Near-End Crosstalk (NEXT): 30.1 dB
- Power-sum NEXT: 27.1 dB
- Attenuation to Crosstalk Ratio (ACR): 6.1 dB
- Power-sum ACR: 3.1 dB
- Return Loss: 10dB
- Propagation Delay: 548 nsec

7.3. CONSTRUCTION METHODS

A. General:

Ensure that the edge switch is UL listed.

Verify that network/field/data patch cords meet all ANSI/EIA/TIA requirements for Category 6 four-pair unshielded twisted pair cabling with stranded conductors and RJ45 connectors.

Contact the City, Division, or NCDIT a minimum of 10 working days prior to installation to allow for the programming of the edge switch.

B. Edge Switch:

Mount the edge switch inside each field cabinet by securely fastening the edge switch to the upper end of the right rear vertical rail of the equipment rack using manufacturer-recommended or Engineer-approved attachment methods, attachment hardware and fasteners.

Ensure that the edge switch is mounted securely in the cabinet and is fully accessible by field technicians without blocking access to other equipment. Verify that fiber-optic jumpers consist of a length of cable that has connectors on both ends, primarily used for interconnecting termination or patching facilities and/or equipment.

7.4. MEASUREMENT AND PAYMENT

Ethernet edge switch will be measured and paid as the actual number of Ethernet edge switches furnished, installed, and accepted.

U-2729

TS-53

Forsyth County

No separate measurement will be made for Ethernet patch cable, small form factor pluggable modules (SFPs), power cord, mounting hardware, nuts, bolts, brackets, or edge switch programming as these will be considered incidental to furnishing and installing the edge switch.

Payment will be made under:

Ethernet Edge Switch.....Each

8. DIGITAL CCTV CAMERA ASSEMBLY

8.1.DESCRPTION

Furnish and install a Digital CCTV Camera Assembly as described in these Project Special Provisions. All new CCTV cameras shall be fully compatible with the video management software currently in use by the Region and the Statewide Traffic Operations Center (STOC). Provide a Pelco Spectra Enhanced low light 30X minimum zoom, Axis Dome Network Camera low light 30X minimum zoom or an approved equivalent that meets the requirements of these Project Special Provisions.

8.2.MATERIALS

A. General

Furnish and install new CCTV camera assembly at the locations shown on the Plans and as approved by the Engineer. Each assembly consists of the following:

- One dome CCTV color digital signal processing camera unit with zoom lens, filter, control circuit, and accessories in a single enclosed unit
- A NEMA-rated enclosure constructed of aluminum with a clear acrylic dome or approved equal Camera Unit housing.
- Motorized pan, tilt, and zoom
- Built-in video encoder capable of H.264/MPEG-4 compression for video-over IP transmission
- Pole-mount camera attachment assembly
- A lightning arrestor installed in-line between the CCTV camera and the equipment cabinet components.
- All necessary cable, connectors and incidental hardware to make a complete and operable system.

B. Camera and Lens

1. Cameras

Furnish a new CCTV camera that utilizes charged-coupled device (CCD) technology or Complementary Metal-Oxide-Semiconductor (CMOS) technology. The camera must meet the following minimum requirements:

- Video Resolution: Minimum 1920x1080 (HDTV 1080p)
- Aspect Ratio: 16:9
- Overexposure protection: The camera shall have built-in circuitry or a protection device to prevent any damage to the camera when pointed at strong light sources, including the sun

- Low light condition imaging
- Wide Dynamic Range (WDR) operation
- Electronic Image Stabilization (EIS)
- Automatic focus with manual override

2. **Zoom Lens**

Furnish each camera with a motorized zoom lens that is a high-performance integrated dome system or approved equivalent with automatic iris control with manual override and neutral density spot filter. Furnish lenses that meet the following optical specifications:

- 30X minimum optical zoom, and 12X minimum digital zoom
- Preset positioning: minimum of 128 presets

The lens must be capable of both automatic and remote manual control iris and focus override operation. The lens must be equipped for remote control of zoom and focus, including automatic movement to any of the preset zoom and focus positions. Mechanical or electrical means must be provided to protect the motors from overrunning in extreme positions. The operating voltages of the lens must be compatible with the outputs of the camera control.

3. **Communication Standards:**

The CCTV camera shall support the appropriate NTCIP 1205 communication protocol (version 1.08 or higher), ONVIF Profile G protocol, or approved equal.

4. **Networking Standards:**

- Network Connection: Minimum 10/100 Mbps auto-negotiate
- Frame Rate: 30 to 60 fps
- Data Rate: scalable
- Built-in Web Server
- Unicast & multicast support
- Two simultaneous video streams (Dual H.264 and MJPEG):
 - Video 1: H.264 (Main Profile, at minimum)
 - Video 2: H.264 or MJPEG
- Supported Protocols: DNS, IGMPv2, NTP, RTSP, RTP, TCP, UDP, DHCP, HTTP, IPv4, IP6
- 130 db Wide Dynamic Range (WDR)

The video camera shall allow for the simultaneous encoding and transmission of the two digital video streams, one in H.264 format (high-resolution) and one in H.264 or MJPEG format (low- resolution).

Initially use UDP/IP for video transport and TCP/IP for camera control transport unless otherwise approved by the Engineer.

The 10/100BaseTX port shall support half-duplex or full-duplex and provide auto negotiation and shall be initially configured for full-duplex.

The camera unit shall be remotely manageable using standard network applications via web browser interface administration. Telnet or SNMP monitors shall be provided.

C. Camera Housing

Furnish new dome style enclosure for the CCTV assembly. Equip each housing with mounting assembly for attachment to the CCTV camera pole. The enclosures must be equipped with a sunshield and be fabricated from corrosion resistant aluminum and finished in a neutral color of weather resistant enamel. The enclosure must meet or exceed NEMA 4X ratings. The viewing area of the enclosure must be tempered glass. The pendant must meet NEMA Type 4X, IP66 rating and use 1-1/2-inch NPT thread. The sustained operating temperature must be -50 to 60C (-58 to 144F), condensing temperature 10 to 100% Relative Humidity (RH).

D. Pan and Tilt Unit

Equip each new dome style assembly with a pan and tilt unit. The pan and tilt unit must be integral to the high-performance integrated dome system. The pan and tilt unit must be rated for outdoor operation, provide dynamic braking for instantaneous stopping, prevent drift, and have minimum backlash. The pan and tilt units must meet or exceed the following specifications:

- Pan: continuous 360 Degrees rotation
- Tilt: up/down +2 to -90 degrees minimum
- Motors: Two-phase induction type, continuous duty, instantaneous reversing
- Preset Positioning: minimum of 128 presets
- Low latency for improved Pan and Tilt Control
- FCC, Class A; UL/cUL Listed

E. Video Ethernet Encoder

Furnish cameras with a built-in digital video Ethernet encoder to allow video-over-IP transmission. The encoder units must be built into the camera housing and require no additional equipment to transmit encoded video over IP networks.

Encoders must have the following minimum features:

- Network Interface: Ethernet 10/100Base-TX (RJ-45 connector)
- Protocols: IPv4, Ipv6, HTTP, UpnP, DNS, NTP, RTP, RTSP, TCP, UDP, IGMP, and DHCP
- Security: SSL, SSH, 802.1x, HTTPS encryption with password-controlled browser interface
- Video Streams: Minimum 2 simultaneous streams, user configurable
- Compression: H.264 (MPEG-4 Part 10/AVC)
- Resolution Scalable: NTSC-compatible 320x176 to 1920x1080 (HDTV 1080p)
- Aspect Ratio: 16:9
- Frame Rate: 1-30 FPS programmable (full motion)
- Bandwidth: 30 kbps – 6 Mbps, configurable depending on resolution
- Edge Storage: SD/SDHC/SDXC slot supporting up to 64GB memory card

F. Control Receiver/Driver

Provide each new camera unit with a control receiver/driver that is integral to the CCTV dome assembly. The control receiver/driver will receive serial asynchronous data initiated from a camera control unit, decode the command data, perform error checking, and drive the pan/tilt unit, camera controls, and motorized lens. As a minimum, the control receiver/drivers must provide the following functions:

- Zoom in/out
- Automatic focus with manual override
- Tilt up/down
- Automatic iris with manual override
- Pan right/left
- Minimum 128 preset positions for pan, tilt, and zoom, 16 Preset Tours, 256 Dome Presets
- Up to 32 Window Blanks.

In addition, each control receiver/driver must accept status information from the pan/tilt unit and motorized lens for preset positioning of those components. The control receiver/driver will relay pan, tilt, zoom, and focus positions from the field to the remote camera control unit. The control receiver/driver must accept “goto” preset commands from the camera control unit, decode the command data, perform error checking, and drive the pan/tilt and motorized zoom lens to the correct preset position. The preset commands from the camera control unit will consist of unique values for the desired pan, tilt, zoom, and focus positions.

G. Electrical

The camera assembly shall support Power-over-Ethernet (PoE) in compliance with IEEE 802.3. Provide any external power injector that is required for PoE with each CCTV assembly.

H. CCTV Camera Attachment to Pole

Furnish and install an attachment assembly for the CCTV camera unit. Use stainless steel banding approved by the Engineer.

Furnish CCTV attachments that allow for the removal and replacement of the CCTV enclosure as well as providing a weatherproof, weather tight, seal that does not allow moisture to enter the enclosure.

Furnish a CCTV Camera Attachment Assembly that can withstand wind loading at the maximum wind speed and gust factor called for in these Special Provisions and can support a minimum camera unit dead load of 45 pounds (20.4 kg).

I. Riser

Furnish material meeting the requirements of Section 1091-3 and 1098-4 of the 2018 Standard Specifications for Roads and Structures. Furnish a 1” riser with weatherhead for instances where the riser is only carrying an Ethernet cable. For installations where fiber optic cable is routed to the cabinet through a 2” riser with heat shrink tubing the Contractor may elect to install the Ethernet cable in the same riser with the fiber cable.

J. Data line Surge Suppression

Furnish data line surge protection devices (SPD) shall meet the following minimum requirements:

- UL497B
- Service Voltage: < 60 V
- Protection Modes: L-G (All), L-L (All)
- Response Time: <5 nanoseconds
- Port Type: Shielded RJ-45 IN/Out
- Clamping Level: 75 V

U-2729**TS-57****Forsyth County**

- Surge Current Rating: 20 kA/Pair
- Power Handling: 144 Watts
- Data Rate: up to 10 GbE
- Operating Temperature: -40° F to + 158° F
- Standards Compliance: Cat-5e, EIA/TIA 568A and EIA/TIA 568B
- Warranty: Minimum of 5-year limited warranty

The data line surge protector shall be designed to operate with Power Over Ethernet (POE) devices. The SPD shall be designed such that when used with shielded cabling, a separate earth ground is not required. It shall be compatible with Cat-5e, Cat 6, and Cat-6A cabling.

Protect the electrical and Ethernet cables from the CCTV unit entering the equipment cabinet with surge protection. Provide an integrated unit that accepts unprotected electrical and Ethernet connections and outputs protected electrical and Ethernet connections.

K. POE Injector

Furnish POE Injectors meeting the following minimum performance requirements and that is compatible with the CCTV Camera and Ethernet Switch provided for the project.

- Working temp/humidity: 14° F to 131° F/maximum 90%, non-condensing
- Connectors: Shielded RJ-45, EIA 568A and EIA 568B
- Input Power: 100 to 240 VAC, 50 to 60 Hz
- Pass Through Data Rates: 10/100/1000 Mbps
- Regulatory: IEEE 802.3at (POE)
- Number of Ports: 1 In and 1 Out
- Safety Approvals: UL Listed

Ensure the POE Injector is designed for Plug-and-Play installation, requiring no configurations and supports automatic detection and protection of non-standard Ethernet Terminal configurations.

8.3.CONSTRUCTION METHODS

A. General

Obtain approval of the camera locations and orientation from the Engineer prior to installing the CCTV camera assembly.

Mount CCTV camera units at a height to adequately see traffic in all directions and as approved by the Engineer. The maximum attachment height is 45 feet above ground level unless specified elsewhere or directed by the Engineer.

Mount the CCTV camera units such that a minimum 5 feet of clearance is maintained between the camera and the top of the pole to ensure adequate lightning protection is provided by the air terminal.

Mount CCTV cameras on the side of poles nearest intended field of view. Avoid occluding the view with the pole.

Install the data line surge protection device and POE Injector in accordance with the manufacturer's recommendations.

Install the riser in accordance with Section 1722 of the 2018 Standard Specifications for Roads and Structures. Install the Ethernet cable in the riser from the field cabinet to the CCTV camera.

B. Electrical and Mechanical Requirements

Install an "Air Terminal and Lightning Protections System" in accordance with the Air Terminal and Lightning Protection System Project Special Provisions for the CCTV Camera Assembly. Ground all equipment as called for in the Standard Specifications, these Special Provisions, and the Plans. **Do not install lightning protection when installing a CCTV camera assembly on a signal pole.**

Install surge protectors on all ungrounded conductors entering the CCTV enclosure.

C. General Test Procedure

Test the CCTV Camera and its components in a series of functional tests and ensure the results of each test meet the specified requirements. These tests should not damage the equipment. The Engineer will reject equipment that fails to fulfill the requirements of any test. Resubmit rejected equipment after correcting non-conformities and re-testing; completely document all diagnoses and corrective actions. Modify all equipment furnished under this contract, without additional cost to the Department, to incorporate all design changes necessary to pass the required tests.

Provide 4 copies of all test procedures and requirements to the Engineer for review and approval at least 30 days prior to the testing start date.

Only use approved procedures for the tests. Include the following in the test procedures:

- A step-by-step outline of the test sequence that demonstrates the testing of every function of the equipment or system tested
- A description of the expected nominal operation, output, and test results, and the pass / fail criteria
- An estimate of the test duration and a proposed test schedule
- A data form to record all data and quantitative results obtained during the test
- A description of any special equipment, setup, manpower, or conditions required by the test

Provide all necessary test equipment and technical support. Use test equipment calibrated to National Institute of Standards and Technology (NIST) standards. Provide calibration documentation upon request.

Conform to these testing requirements and the requirements of these specifications. It is the Contractor's responsibility to ensure the system functions properly even after the Engineer accepts the CCTV test results.

Provide 4 copies of the quantitative test results and data forms containing all data taken, highlighting any non-conforming results and remedies taken, to the Engineer for approval. An authorized representative of the manufacturer must sign the test results and data forms.

D. Compatibility Tests**1. CCTV System**

Compatibility Tests are applicable to CCTV cameras that the Contractor wishes to furnish but are of a different manufacturer or model series than the existing units installed in the Region. If required, the Compatibility Test shall be completed and accepted by the Engineer prior to approval of the material submittal.

The Compatibility Test shall be performed in a laboratory environment at a facility chosen by the Engineer based on the type of unit being tested. Provide notice to the Engineer with the material submitted that a Compatibility Test is requested. The notice shall include a detailed test plan that will show compatibility with existing equipment. The notice shall be given a minimum of 15 calendar days prior to the beginning of the Compatibility Test.

The Contractor shall provide, install, and integrate a full-functioning unit to be tested. The Department will provide access to existing equipment to facilitate these testing procedures. The Engineer will determine if the Compatibility Test was acceptable for each proposed device. To prove compatibility the Contractor is responsible for configuring the proposed equipment at the applicable Traffic Operations Center (TOC) with the accompaniment of an approved TOC employee.

E. Operational Field Test (On-Site Commissioning)**1. CCTV System**

Final CCTV locations must be field verified and approved by the Engineer. Perform the following local operational field tests at the camera assembly field site in accordance with the test plans and in the presence of the Engineer. The Contractor is responsible for providing a laptop for camera control and positioning during the test. After completing the installation of the camera assemblies, including the camera hardware, power supply, and connecting cables, the contractor shall:

F. Local Field Testing

Furnish all equipment and labor necessary to test the installed camera and perform the following tests before any connections are made.

- Verify that physical construction has been completed.
- Inspect the quality and tightness of ground and surge protector connections.
- Check the power supply voltages and outputs, check connection of devices to power source.
- Verify installation of specified cables and connection between the camera, PTZ, camera control receiver, and control cabinet.
- Make sure cabinet wiring is neat and labeled properly; check wiring for any wear and tear; check for exposed or loose wires.
- Perform the CCTV assembly manufacturer's initial power-on test in accordance with the manufacturer's recommendation.
- Set the camera control address.
- Exercise the pan, tilt, zoom, and focus operations along with preset positioning, and power on/off functions.
- Demonstrate the pan, tilt and zoom speeds and movement operation meet all applicable standards, specifications, and requirements.

- Define, test and/or change presets.
- Ensure camera field of view is adjusted properly and there are no objects obstructing the view.
- Ensure camera lens is dust-free.
- Ensure risers are bonded and conduits entering cabinets are sealed properly.
- Lightning arrestor bonded correctly.

G. Central Operations Testing

- Interconnect the CCTV Camera’s communication interface device with one of the following methods as depicted on the plans:
 - communication network’s assigned Ethernet switch and assigned fiber-optic trunk cable and verify a transmit/receive LED is functioning and that the CCTV camera is fully operational at the TOC.

OR

- to the DOT furnished cellular modem and verify a transmit/receive LED is functioning and that the CCTV camera is fully operational at the TOC.
- Exercise the pan, tilt, zoom, and focus operations along with preset positioning, and power on/off functions.
- Demonstrate the pan, tilt and zoom speeds and movement operation meet all applicable standards, specifications, and requirements.
- Define, test and/or change presets.

Approval of Operational Field Test results does not relieve the Contractor to conform to the requirements in these Project Special Provisions. If the CCTV system does not pass these tests, document a correction or substitute a new unit as approved by the Engineer. Re-test the system until it passes all requirements.

8.4.MEASUREMENT AND PAYMENT

Digital CCTV Camera Assembly will be measured and paid as the actual number of digital CCTV assemblies furnished, installed, integrated, and accepted. No separate measurement will be made for electrical cabling, connectors, CCTV camera attachment assemblies, conduit, condulets, risers, grounding equipment, surge protectors, PoE Injectors, PoE Cable, Air Terminal and Lightning Protection System, compatibility testing, operational testing or any other equipment or labor required to install the digital CCTV assembly.

Payment will be made under:

Digital CCTV Camera AssemblyEach

9. CCTV FIELD EQUIPMENT CABINET

9.1.DESCRPTION

For standalone CCTV Camera installations, furnish pole mounted cabinets and all necessary hardware in accordance with the plans and specifications to house CCTV control and transmission equipment.

9.2.MATERIALS

A. CCTV Cabinet

Furnish Type 336S style or equivalent pole-mounted cabinet meeting the following minimum requirements:

- Single doors on both front and rear of cabinet;
- Grounding bus bar;
- 19-inch rack system for mounting of all devices in the cabinet;
- Pull-out shelf drawer for laptop and maintenance use;
- Maintenance access connections;
- LED lighting;
- Ventilation fans;
- 120VAC power supply;
- 120VAC ground fault circuit interrupter (GFCI)-protected duplex outlets for tools;
- 120VAC surge-protected duplex outlets for equipment.
- Lightning and surge protection on incoming and outgoing electrical lines (power and data);
- UPS with sufficient capacity to hold hub's electrical load for 4 hours.
- Managed Ethernet Edge switch if called for in the plans (paid separately);
- Fiber-optic interconnect centers if called for in the plans (paid separately)

Furnish terminal blocks for power for cabinet CCTV and communications devices as needed to accommodate the number of devices in the cabinet.

Furnish all conduits, shelving, mounting adapters, and other equipment as necessary to route cabling, mount equipment and terminate conduit in the equipment cabinet.

B. Shelf Drawer

Provide a pull out, hinged-top drawer, having sliding tracks, with lockout and quick disconnect feature, such as a Vent-Rak Retractable Writing Shelf, #D-4090-13 or equivalent in the equipment cabinet. Furnish a pullout drawer that extends a minimum of 14 inches that is capable of being lifted to gain access to the interior of the drawer. Minimum interior dimensions of the drawer are to be 1 inch high, 13 inches deep, and 16 inches wide. Provide drawers capable of supporting a 40-pound device or component when fully extended.

C. Cabinet Light

Each cabinet must include two (2) LED lighting fixtures (one front, one back) mounted horizontally inside the top portion of the cabinet. The fixtures must include a cool white lamp and

must be operated by normal power factor UL-listed ballast. A door-actuated switch must be installed to turn on the applicable cabinet light when the front door or back door is opened. The lights must be mounted not to interfere with the upper door stay.

D. Surge Protection for System Equipment

Each cabinet must be provided with devices to protect the CCTV and communications equipment from electrical surges and over voltages as described below.

1. Main AC Power Input

Each cabinet must be provided with a hybrid-type, power line surge protection device mounted inside the power distribution assembly. The protector must be installed between the applied line voltage and earth ground. The surge protector must be capable of reducing the effect of lighting transient voltages applied to the AC line. The protector must be mounted inside the Power Distribution Assembly housing facing the rear of the cabinet. The protector must include the following features and functions:

- Maximum AC line voltage: 140 VAC.
- Twenty pulses of peak current, each of which must rise in 8 microseconds and fall in 20 microseconds to ½ the peak: 20000 Amperes.
- The protector must be provided with the following terminals:
 - Main Line (AC Line first stage terminal).
 - Main Neutral (AC Neutral input terminal).
 - Equipment Line Out (AC line second state output terminal, 19 amps).
 - Equipment Neutral Out (Neutral terminal to protected equipment).
 - GND (Earth connection).
- The Main AC line in and the Equipment Line out terminals must be separated by a 200 Microhenry (minimum) inductor rated to handle 10 AMP AC Service.
- The first stage clamp must be between Main Line and Ground terminals.
- The second stage clamp must be between Equipment Line Out and Equipment Neutral.
- The protector for the first and second stage clamp must have an MOV or similar solid state device rated at 20 KA and must be of a completely solid-state design (i.e., no gas discharge tubes allowed).
- The Main Neutral and Equipment Neutral Out must be connected together internally and must have an MOV similar solid-state device or gas discharge tube rated at 20 KA between Main Neutral and Ground terminals.
- Peak Clamp Voltage: 350 volts at 20 KA. (Voltage measured between Equipment Line Out and Equipment Neutral Out terminals. Current applied between Main Line and Ground Terminals with Ground and Main Neutral terminals externally tied together).
- Voltage must never exceed 350 volts.
- The Protector must be epoxy-encapsulated in a flame-retardant material.
- Continuous service current: 10 Amps at 120 VAC RMS.
- The Equipment Line Out must provide power to cabinet CCTV and communications equipment.

2. Ground Bus

Provide a neutral bus that is not connected to the earth ground or the logic ground anywhere within the cabinet. Ensure that the earth ground bus and the neutral ground bus each have ten compression type terminals, each of which can accommodate wires ranging from number 14 through number 4 AWG.

9.3.CONSTRUCTION METHODS

A. General

For each field equipment cabinet installation, use stainless steel banding or other methods approved by the Engineer to fasten the cabinet to the pole. Install field equipment cabinets so that the height to the middle of the enclosure is 4 feet from ground level. No risers shall enter the top or sides of the equipment cabinet.

Install all conduits, condulets, and attachments to equipment cabinets in a manner that preserves the minimum bending radius of cables and creates waterproof connections and seals.

Install a UPS in each cabinet and power all CCTV and communications equipment from the UPS.

9.4.MEASUREMENT AND PAYMENT

Field equipment cabinet will be measured and paid as the actual number of CCTV equipment cabinets furnished, installed and accepted.

No payment will be made for the UPS, cabling, connectors, cabinet attachment assemblies, conduit, condulets, risers, grounding equipment, surge protectors, or any other equipment or labor required to install the field equipment cabinet and integrate the cabinets with the CCTV equipment.

Payment will be made under:

Pay Item	Pay Unit
Field Equipment Cabinet	Each

10. CCTV WOOD POLE

10.1. DESCRIPTION

Furnish and install wood poles, grounding systems and all necessary hardware for CCTV camera installations. Reference applicable Sections of Article 1720 of the 2018 Standard Specifications for Roads and Structures for Materials and Construction.

Furnish an air terminal and lightning protection system in accordance with the “Air Terminal & Lightning Protection System” Project Special Provisions.

Furnish and install wood poles with grounding systems and all necessary hardware in accordance with Section 1720 of the 2018 Standard Specifications for Roads and Structures.

10.2. MATERIALS

Material, equipment, and hardware furnished under this section shall be pre-approved on the Department’s QPL. For Wood poles refer to Sub articles 1082-3(F) Treated Timber and Lumber – Poles and 1082-4(A) – General; 1082-4 (B) – Timber Preservatives; 1082-4(G) – Poles; in the 2018 Standard Specifications for Roads and Structures.

10.3. CCTV WOOD POLE

Unless otherwise specified in the Plans, furnish Class 3 or better wood poles that are a minimum of 60’ long to permit the CCTV camera to be mounted approximately 45 feet above the ground and a minimum 5 feet from the top of the pole.

10.4. CONSTRUCTION METHODS

Mark final pole locations and receive approval from the Engineer before installing poles. Comply with all requirements of Section 1720-3 of the 2018 Standard Specifications for Roads and Structures.

Install the required Air Terminal & Lightning Protection System as described in the Air Terminal & Lighting Protection Specifications and as referenced in the following Typical Details:

- CCTV Camera Installation for Wood Pole with Aerial Electrical Service
- CCTV Camera Installation for Wood Pole with Underground Electrical Service

10.5. MEASUREMENT AND PAYMENT

CCTV Wood Pole will be measured and paid as the actual number of wood poles for CCTV camera furnished, installed and accepted.

No measurement will be made for equipment, labor and materials, to install the wood pole as these items of work will be incidental to furnishing and installing CCTV wood poles.

No measurement will be made for furnishing and installing the “Air Terminal and Lightning Protection System” as this will be considered incidental to the “CCTV Wood Pole” installation.

Payment will be made under:

CCTV Wood PoleEach

11. AIR TERMINAL & LIGHTNING PROTECTION SYSTEM

11.1. DESCRIPTION

Furnish an air terminal and lightning protection system that is comprised of items meeting UL 96 and UL 467 product standards for lightning protection and installed to be compliant with the National Fire Protection Association 780 Standards for Lightning Protection Systems. The lightning protection system shall consist of, as a minimum, an Air Terminal, vertical Air Terminal Base (wood pole) or Air Terminal Rod Clamps (metal pole), 28-Strand bare-copper lightning conductor, 4-point grounding systems (grounding electrodes), #4 AWG copper bonding conductors, marker tape and other miscellaneous hardware.

11.2. Materials

A. General

Reference the following Typical Details where applicable:

- CCTV Camera Installation for Metal Pole with Aerial Electrical Service
- CCTV Camera Installation for Metal Pole with Underground Electrical Service
- CCTV Camera Installation for Wood Pole with Aerial Electrical Service
- CCTV Camera Installation for Wood Pole with Underground Electrical Service

B. Wood Pole

Furnish a UL Listed Class II, copper clad minimum 48" long by ½" diameter air terminal. Ensure the air terminal has a tapered tip with a rounded point on one end and is threaded on the connection end with standard Unified Coarse (UNC) 13 threads per inch.

Furnish a copper vertical air terminal base that has internal threading to accept a ½" diameter air terminal with UNC 13 threads per inch. Provide a base that allows for a minimum ¼" mounting hole to secure the base to the vertical side of a wood pole. Ensure the air terminal base includes (2) 5/16" cap screws to secure the bare copper lightning conductor. Additionally, provide (2) ½" copper tube straps (conduit clamps) to secure the air terminal and bare copper lightning conductor to the pole.

C. Metal Pole

Furnish a UL Listed Class II, stainless steel minimum 48" long by ½" diameter air terminal with a tapered tip with a rounded point on one end. No threading is required on the opposing end.

Furnish an air terminal rod clamp manufactured out of 304 stainless steel. Ensure the air terminal rod clamp has two horizontal support arms that are 2" wide by 3/16" thick and design to offset the air terminal approximately 8" away from the metal pole. Ensure the support arms at the point where the air terminal is to be installed has an internal crease to secure the air terminal along with four (4) bolts to provide the clamping action between the two support arms. Provide two (2) stainless steel banding clamps to secure the air terminal rod clamp's base plate to the metal pole.

D. Copper Lightning Conductor and Ground Rods

Furnish a Class II rated copper lightning conductor which consists of 28 strands (minimum) of 15 AWG copper wires to form a rope-lay bare copper lightning conductor. Furnish 5/8" diameter, 10-foot-long copper-clad steel ground rods with a 10-mil thick copper cladding to serve as an integral part of the 4-point grounding system. Furnish irreversible mechanical clamps to secure the 28-strand lightning conductor, #4 AWG bare copper ground wires and grounding electrodes together to complete the grounding system.

11.3. Construction Methods

A. Wood Pole

Install the vertical air terminal base approximately 12" below the top of the wood pole and install the air terminal to the threaded connection on the base. Install a ½" copper tube strap (conduit clamp) over the air terminal, 6" from the top of the pole. Additionally, secure the copper lightning conductor under both 5/16" diameter cap screws located on the base. Install an additional ½" copper tube strap (conduit clamp) over the bare copper lightning conductor, 6" below the air terminal base. Locate the ¼" mounting hole on the vertical air terminal base and install a ¼" by 3" (minimum) long lag bolt through the base and into the wood pole to support the air terminal assembly.

Route the bare copper lightning conductor to maintain maximum horizontal separation from any risers that traverse up the pole. Secure the bare copper lightning conductor to the pole on 24" centers using copper cable clips. From the bottom of the pole (ground level) install a 2" by 10' long PVC U-Guard over the bare copper lightning conductor to protect the cable from vandalism.

B. Metal Pole

Install two (2) stainless steel air terminal rod clamps to the side of the metal pole structure starting at 6” below the top of the pole with the second air terminal clamp 12” from the top of the pole (approximately 6” of separation between the 2 clamps). Secure each air terminal rod clamp to the pole structure with two (2) stainless steel banding clamps. Install the air terminal between the horizontal support arms on each air terminal rod clamp and tighten the bolts to provide a secure connection.

C. Copper Lightning Conductor and Ground Rods

Install the 4-point grounding system by installing a central grounding electrode that is surrounded by a minimum of three (3) additional grounding electrodes spaced approximately 20 feet away from the central grounding electrode and approximately 120 degrees apart. Interconnect each grounding electrode using a #4 AWG bare copper conductor back to the central grounding electrode using irreversible mechanical crimps. Additionally, using an irreversible mechanical crimp, connect the bare copper lightning conductor to the central grounding electrode. Install each grounding electrode and its corresponding #4 AWG bare copper grounding wire and 28 strand copper lightning conductor such that the wires are 24” below grade. Install marker tape 12” below grade and above all grounding conductors.

In instances where right-of-way does not allow for ground rod spacing as required above, reference the 2018 Roadway Standard Drawings - Section 1700.02 “Electrical Service Grounding” for “Limited Shoulder” or “Restricted Space” installation alternatives.

Prior to connecting the lightning protection system to an electrical service, perform a grounding electrode test on the lightning protection system to obtain a maximum of 20 ohms or less. Install additional grounding electrodes as need to obtain the 20 ohms or less requirement. The grounding electrode resistance test shall be verified or witnessed by the Engineer or the Engineer’s designated representative.

Follow test equipment’s procedures for measuring grounding electrode resistance. When using clamp-type ground resistance meters, readings of less than one ohm typically indicate a ground loop. Rework bonding and grounding circuits as necessary to remove ground loop circuits and retest. If a ground loop cannot be identified and removed to allow the proper use of a clamp-type ground resistance meter, use the three-point test method. Submit a completed inductive Loop & Grounding Test Form available on the Department’s website.

11.4. Measurement and Payment

No measurement will be made for furnishing and installing the “Air Terminal and Lightning Protection System” as this will be considered incidental to “CCTV Metal Pole” & “CCTV Wood Pole” installations.

12. ELECTRICAL SERVICE FOR ITS DEVICES**12.1. DESCRIPTION**

Install new electrical service equipment as shown in the plans. Installation of all new electrical service pedestals, poles, and meter base/disconnect combination panels shall be the first item of work on this project to expedite the power service connections. Comply with the National Electrical Code (NEC), the National Electrical Safety Code (NESC), the Standard Specifications, the Project Special Provisions, and all local ordinances. All work involving electrical service shall be coordinated with the appropriate utility company and the Engineer.

Obtain the maximum available ground fault current from the utility company. Print this information on a durable label and adhere to the dead front of the disconnect.

12.2. MATERIAL

A. Meter Base/Disconnect Combination Panel

Furnish and install new meter base/disconnect combination panels as shown in the Plans. Provide meter base/disconnect combination panels that have a minimum 125A main service disconnect and a minimum of eight (8) additional spaces. Furnish a single pole 15A circuit breaker at CCTV locations. Furnish a double pole 50A circuit breakers at single DMS locations. Furnish a double pole 100A circuit breakers at dual DMS locations. Furnish each with a minimum of 10,000 RMS symmetrical amperes short circuit current rating in a lockable NEMA 3R enclosure. Ensure meter base/ disconnect combination panel is listed as meeting UL Standard UL-67 and marked as being suitable for use as service equipment. Ensure circuit breakers are listed as meeting UL-489. Place barriers so that no uninsulated, ungrounded service busbar or service terminal is exposed to inadvertent contact by persons or maintenance equipment while servicing load terminations. Fabricate enclosure from galvanized steel and electrostatically apply dry powder paint finish, light gray in color, to yield a minimum thickness of 2.4 mils. All exterior surfaces must be powder coated steel. Provide ground bus and neutral bus with a minimum of four terminals and a minimum wire capacity range of number 8 through number 3/0 AWG.

Furnish NEMA Type 3R combinational panels rated 100 Ampere minimum for overhead services and 200 Ampere minimum for underground services that meet the requirements of the local utility. Provide meter base with sockets' ampere rating based on sockets being wired with a minimum of 167 degrees F insulated wire. Furnish 4 terminal, 600 volt, single phase, 3-wire meter bases that comply with the following:

- Line, Load, and Neutral Terminals accept 4/0 AWG and smaller Copper/Aluminum wire
- With or without horn bypass
- Made of galvanized steel
- Listed as meeting UL Standard US-414
- Overhead or underground service entrance specified.

Furnish 1.5" watertight hub for threaded rigid conduit with meter base.

At the main service disconnect, furnish and install UL-approved lightning arrestors that meet the following requirements:

Type of design	Silicon Oxide Varistor
Voltage	120/240 Single Phase, 3 wire
Maximum current	100,000 amps
Maximum energy	3000 joules per pole
Maximum number of surges	Unlimited
Response time one milliamp test	5 nanoseconds

U-2729

TS-68

Forsyth County

Response time to clamp 10,000 amps	10 nanoseconds
Response time to clamp 50,000 amps	25 nanoseconds
Leak current at double the rated voltage	None
Ground wire	Separate

B. 3-Wire Copper Service Entrance Conductors

Furnish 3-wire stranded copper service entrance conductors with THWN rating. Provide conductors with black, red, and white insulation that are intended for power circuits at 600 Volts or less and comply with the following:

- Listed as meeting UL Standard UL-83
- Meets ASTM B-3 and B-8 or B-787 standards.

See the Plans for wire sizes and quantities.

C. 3-Wire Copper Feeder Conductors

Furnish 3-wire stranded copper feeder conductors with THWN rating for supplying power to ITS field equipment cabinets. Provide conductors with black or red, white, and green insulation that are intended for power circuits at 600 Volts or less and comply with the following:

- Listed as meeting UL Standard UL-83
- Meets ASTM B-3 and B-8 or B-787 standards.

See the Plans for wire sizes and quantities.

D. Grounding System

Furnish 5/8"x10' copper clad steel grounding electrodes (ground rods), #4 AWG solid bare copper conductors. Comply with the NEC, Standard Specifications, these Project Special Provisions, and the Plans.

12.3. CONSTRUCTION METHODS

A. General

Coordinate with the Engineer and the utility company to de-energize the existing service temporarily prior to starting any modifications.

Permanently label cables at all access points using nylon tags labeled with permanent ink. Ensure each cable has a unique identifier. Label cables immediately upon installation. Use component name and labeling scheme approved by the Engineer.

B. Meter Base/Disconnect Combination Panel

Install meter base/disconnect combination panels with lightning arrestors as called for in the Plans. At all new DMS locations, route the feeder conductors from the meter base/disconnect to the DMS equipment cabinet in conduit. At all new CCTV locations, route the feeder conductors from the meter base/disconnect to the CCTV equipment cabinet in conduit. Provide rigid galvanized conduit for above ground and PVC for below ground installations.

U-2729

TS-69

Forsyth County

C. 3-Wire Copper Service Entrance Conductors

At locations shown in the Plans, furnish and install 3-wire THWN stranded copper service entrance conductors in 1.25 inch rigid galvanized risers as shown in the plans. Install a waterproof hub on top of the electrical service disconnect for riser entrance/exit. Size the conductors as specified in the Plans. Comply with the Standard Specifications and Standard Drawings and all applicable electrical codes.

D. 3-Wire Copper Feeder Conductors

At locations shown in the Plans, install 3-wire THWN stranded copper feeder conductors to supply 120 VAC to the CCTV field equipment cabinets. Size the conductors as specified in the Plans. Comply with the Standard Specifications and Standard Drawings and all applicable electrical codes.

E. Grounding System

Install ground rods as indicated in the Plans. Connect the #4 AWG grounding conductor to ground rods using an irreversible mechanical crimping method. Test the system to ensure a ground resistance of 20-ohms or less is achieved. Drive additional ground rods as necessary or as directed by the Engineer to achieve the proper ground resistance.

12.4. MEASUREMENT AND PAYMENT

Meter base/disconnect combination panel will be measured and paid as the actual number of complete and functional meter base/disconnect combination panel service locations furnished, installed and accepted. Breakers, lightning arrestors, exposed vertical conduit runs to the cabinet, and any remaining hardware, fittings, and conduit bodies to connect the electrical service to the cabinet will be considered incidental to meter base/disconnect combination panels.

3-Wire copper service entrance conductors will be incidental to furnish and installing the meter base/disconnect combination panel. All other required feeder conductors will be paid for separately.

3-Wire copper feeder conductors will be measured and paid as the actual linear feet of 3-wire THWN stranded copper feeder conductors furnished, installed and accepted. Payment is for all three conductors. Measurement will be for the actual linear footage of combined conductors after all terminations are complete. No separate payment will be made for each individual conductor. No separate payment will be made for different wire sizes. No payment will be made for excess wire in the cabinets.

5/8" X 10' grounding electrode (ground rod) will be measured and paid as the actual number of 5/8" copper clad steel ground rods furnished, installed and accepted. No separate payment will be made for irreversible mechanical crimping tool as this will be considered incidental to the installation of the ground rod.

#4 solid bare grounding conductor will be measured and paid as the actual linear feet of #4 AWG solid bare copper grounding conductor furnished, installed and accepted. Measurement will be along the approximate centerline from the base of the electrical service disconnect to the last grounding electrode.

Payment will be made under:

Pay Item**Pay Unit**

U-2729**TS-70****Forsyth County**

Meter Base/Disconnect Combination Panel	Each
3-Wire Copper Service Entrance Conductors.....	Linear Foot
3-Wire Copper Feeder Conductors	Linear Foot
5/8" X 10' Grounding Electrode.....	Each
#4 Solid Bare Grounding Conductor	Linear Foot

13. OBSERVATION PERIOD FOR ITS DEVICES

13.1. 30-DAY OBSERVATION PERIOD

The 30-Day Observation Period shall be considered part of work to be completed by the project completion date.

Upon successful completion of all project work the 30-day Observation Period may commence. Examples of project work includes but is not limited to:

- Installation of all project devices and communications infrastructure.
- Field Acceptance Testing of all devices.
- Central System Testing of all devices and network communications.
- Correction of all deficiencies and punch list items. (including minor construction items)

This observation consists of a 30-day period of normal, day-to-day operations of the field equipment in operation with new or existing central equipment without any failures. The purpose of this period is to ensure that all components of the system function in accordance with the Plans and these Project Special Provisions.

Respond to system or component failures (or reported failures) that occur during the 30-day Observation Period within twenty-four (24) hours. Correct any failures within forty-eight (48) hours (includes time of notification). Any failure that affects a major system component as defined below for more than forty-eight (48) hours will suspend the timing of the 30-day Observation Period beginning at the time when the Contractor is was notified that the failure occurred. After the cause of such failures has been corrected, timing of the 30-day Observation Period will resume. System or component failures that necessitate a redesign of any component or a failure in any of the major system components exceeding a total of three (3) occurrences will terminate the 30-day Observation Period for that system. The 30-day Observation Period will be restarted from day zero when the redesigned components have been installed and/or the failures corrected. The major system components are:

- CCTV Cameras and Central Operations
- Dynamic Message Sign (DMS) and Central equipment/Operations
- Portable Changeable Message Sign (PCMS)
- Communications infrastructure (examples: Fiber, Radios, Ethernet Switches, Core Switches, etc.)
- Any other ITS Devices not named above (examples: DSRC radios, Radar and Out-of-Street Detection, etc.)

U-2729**TS-71****Forsyth County****13.2. FINAL ACCEPTANCE**

Final system acceptance is defined as the time when all work and materials described in the Plans and these Project Special Provisions have been furnished and completely installed by the Contractor; all parts of the work have been approved and accepted by the Engineer; and successful completion of the 30-day observation period.

The completed System will be ready for final acceptance upon the satisfactory completion of all acceptance tests as detailed in their respective Section of the Project Special provisions; the rectification of all punch-list discrepancies; and the submittal of all project documentation including as-built plans.

13.3. MEASUREMENT AND PAYMENT

There will be no payment for this item of work as it is incidental to the project as a whole and to the item of work in which it is associated.

ST-1

Project U-2729

Forsyth County

Project Special Provisions

Structure

Table of Contents

	Page #
Maintenance and Protection of Traffic Beneath Proposed Structure at Station 33+99.11 -L-	(8-13-04)ST-2
Steel Reinforced Elastomeric Bearings	(6-22-16)ST-3
Thermal Sprayed Coatings (Metallization)	(12-1-17)ST-4
Strip Seal Expansion Joints	(6-25-20)ST-6
Falsework and Formwork	(2-14-22)ST-11
Submittal of Working Drawings	(2-14-22)ST-18
Crane Safety	(6-20-19)ST-24
Grout for Structures	(12-1-17)ST-25
Asbestos Assessment for Bridge Demolition and Renovation Activities	(12-30-15)ST-26

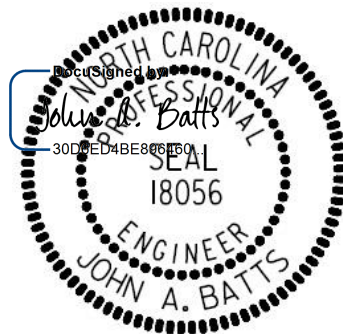

3/24/2023 | 8:04 AM PDT

ST-2

MAINTENANCE AND PROTECTION OF TRAFFIC **BENEATH PROPOSED STRUCTURE AT STATION 33 + 99.11 -L-**

(8-13-04)

1.0 GENERAL

Maintain traffic on SR 1672 (W. Hanes Mill Rd.) as shown in Traffic Control Plans and as directed by the Engineer.

Provide a minimum temporary vertical clearance of 15.59 ft at all times during construction.

Submit plans and calculations for review and approval for protecting traffic and bracing girders, as described herein, at the above station before beginning work at this location. Have the drawings and design calculations prepared, signed, and sealed by a North Carolina Registered Professional Engineer. The approval of the Engineer will not relieve the Contractor of the responsibility for the safety of the method or equipment.

2.0 PROTECTION OF TRAFFIC

Protect traffic from any operation that affords the opportunity for construction materials, equipment, tools, etc. to be dropped into the path of traffic beneath the structure. Based on Contractor means and methods determine and clearly define all dead and live loads for this system, which, at a minimum, shall be installed between beams or girders over any travelway or shoulder area where traffic is maintained. Install the protective system before beginning any construction operations over traffic. In addition, for these same areas, keep the overhang falsework in place until after the rails have been poured.

3.0 BRACING GIRDERS

Brace girders to resist wind forces, weight of forms and other temporary loads, especially those eccentric to the vertical axis of the member during all stages of erection and construction. Before casting of intermediate diaphragms, decks, or connecting steel diaphragms do not allow the horizontal movement of girders to exceed ½ inch.

4.0 BASIS OF PAYMENT

Payment at the contract unit prices for the various pay items will be full compensation for the above work.

ST-3

STEEL REINFORCED ELASTOMERIC BEARINGS

(6-22-16)

The 2018 Standard Specifications shall be revised as follows:

In **Section 1079-2(A) – Elastomeric Bearings** add the following after the second paragraph:

Internal holding pins are required for all shim plates when the contract plans indicate the structure contains the necessary corrosion protection for a corrosive site.

Repair laminated (reinforced) bearing pads utilizing external holding pins via vulcanization. Submit product data for repair material and a detailed application procedure to the Materials and Tests Unit for approval before use and annually thereafter.

ST-4

THERMAL SPRAYED COATINGS (METALLIZATION)

(12-1-2017)

1.0 DESCRIPTION

Apply a thermal sprayed coating (TSC) and sealer to metal surfaces in accordance with the Thermal Sprayed Coatings (Metallization) Program and as specified herein when called for on the plans or by other Special Provisions. Use only Arc Sprayed application methods to apply TSC. The Engineer must approve other methods of application.

The Thermal Sprayed Coatings (Metallization) Program is available on the Materials and Tests Unit website.

2.0 QUALIFICATIONS

Only use NCDOT approved TSC Contractors meeting the requirements outlined in the Thermal Sprayed Coatings (Metallization) Program.

3.0 MATERIALS

Use only materials meeting the requirements of Section 7 of the Thermal Sprayed Coatings (Metallization) Program.

4.0 SURFACE PREPARATION AND TSC APPLICATION

Surface preparation of TSC surfaces shall meet the requirements of Section 8 of the Thermal Sprayed Coatings (Metallization) Program. Apply TSC with the alloy to the thickness specified on the plans or as required by Thermal Sprayed Coatings (Metallization) Program.

5.0 INSPECTION AND TESTING

The TSC Contractor must conduct inspections and tests listed in the Thermal Sprayed Coatings (Metallization) Program.

6.0 REPAIRS

Perform all shop repairs in accordance with the procedures outlined in the Thermal Sprayed Coatings (Metallization) Program.

Repairs associated with field welding shall be made by removing the existing metallizing by blast or power tool cleaning. Affected areas shall be addressed as follows:

- For Marine Environments, incorporate a minimum surface preparation in accordance with SSPC SP-11 (Power Tool Cleaning to Bare Metal) and require an approved epoxy mastic coating applied in accordance with the manufacturer's recommendation. Apply a minimum of two (2) coats at a rate of 5-7 (WFT) per coat to the affected area.

ST-5

- For Non-Marine Environments, incorporate a minimum surface preparation in accordance with SSPC SP-11 (Power Tool Cleaning to Bare Metal) and require an approved organic zinc-rich coating applied in accordance with the manufacturer's recommendation. Apply a minimum of two (2) coats at a rate of 5-7 (WFT) per coat to the affected area.
 1. Minor localized areas less than or equal to 0.1 ft² with exposed substrate shall be repaired as outlined above for marine and non-marine environments.
 2. Large localized areas greater than 0.1 ft² with exposed substrate shall require the Contractor to submit a detailed repair procedure to the Engineer for review and approval.
- Repair methods for areas where the substrate has not been exposed shall be mutually agreed upon between the Contractor and TSC Contractor as approved by the Engineer.

7.0 TWELVE MONTH OBSERVATION PERIOD

All TSC materials applied under the Thermal Sprayed Coatings (Metallization) Program shall be evaluated twelve (12) months after project acceptance for defective materials and workmanship.

8.0 BASIS OF PAYMENT

The contract price bid for the metal component to which the TSC is applied will be full compensation for the thermal sprayed coating.

ST-6

STRIP SEAL EXPANSION JOINTS

(06-25-2020)

1.0 GENERAL

This Special Provision covers furnishing and installing strip seal expansion joints as shown on the contract drawings and in accordance with this Special Provision, the Standard Specifications and the manufacturer's recommendation. All materials, labor, equipment, and incidentals necessary for proper installation of the strip seal expansion joints are included.

2.0 MATERIALS

Provide strip seal expansion joints capable of accommodating a total movement measured parallel to the centerline of the roadway as shown on plans. The components of the expansion joint include steel retainer rails and a neoprene seal gland.

The steel retainer rails shall consist of a "P" shape profile configuration with anchor studs welded to the concrete face. The rails shall have a minimum height of 8 inches, a minimum thickness of ½ inch and a maximum top surface (at the riding surface) width of 2 inches. Use AASHTO M270 Grade 36 or Grade 50 steel for the steel retainer rails.

The neoprene gland shall be extruded synthetic rubber with virgin polychloroprene as the only polymer. The gland manufacturer shall provide a Type 4 certification, in accordance with the Standard Specifications, attesting the gland has been tested and meets the following minimum properties:

PHYSICAL PROPERTY	TEST METHOD	REQUIREMENTS
Tensile Strength, psi (min.)	ASTM D412	2000
Elongation at break, % (min.)	ASTM D412	250
Hardness, Type A durometer, points	ASTM D2240 Modified	60 ± 10
Oven aging, 70h @ 212°F Tensile strength, % change (max.) Elongation, % change (max.) Hardness, points change (max.)	ASTM D573	-20 -20 0 to +10
Oil Swell, ASTM Oil No. 3, 70h @ 212°F Weight change, % (max.)	ASTM D471	45
Ozone resistance 20% strain, 300 pphm in air 70h @ 104°F	ASTM D1149 Modified	No cracks
Low temperature stiffening, 7 days @ 14°F Hardness, Type A durometer, points change	ASTM D2240	0 to +15
Compression Set,	ASTM D395	40%

ST-7

70h @ 212°F (max.)	Method B (modified)	
--------------------	---------------------	--

3.0 SHOP DRAWINGS

Submit a set of complete shop drawings to the Engineer via email for review, comments and acceptance and carbon copy (cc) the Structures Management Unit Working Drawing Review Group (SMU-wdr@ncdot.gov). Send the drawings well in advance of the scheduled installation time for the strip seal expansion joint rail. Prior to submitting the shop drawings, have someone, other than the draftsman who prepares the drawings, check all detailed drawings and include the signatures of both the draftsman and checker on each sheet of the drawings. The Engineer returns unchecked drawings to the Contractor.

Steel retainer rails shall consist of one-piece construction including upturns. Welding two or more components to obtain the required cross-sectional shape is not permitted. Show all dimensions, anchor stud locations, welded splice details, splice locations and any other details or data necessary to fabricate the joint on the shop drawings. Include the joint model number and joint movement range. Draw all details to scale. Identify, in detail, welding procedures to be performed in fabricating the joint. As a minimum, also show the following on the drawings:

- All field splice locations. Steel retainer rail field splices are only permitted at crown points, locations with abrupt changes in the deck slab cross slope, and at travel lane lines. Splices within travel lanes are not permitted and splicing on edge lines is not required. For the location of travel lane markings at the strip seal expansion joint, see the structure plans. At the field splice locations, locate the horizontal stud anchors 3 inches from the centerline of the splice.
- Details of the shipping device for the steel retainer rail assemblies. Ensure the device is capable of resisting shipping and handling forces without causing damage to the steel retainer rail assemblies or metallized coating.
- The method of supporting steel retainer rails horizontally and vertically during joint installation and placement of concrete to ensure stability and proper alignment. Ensure the method is capable of resisting construction forces without causing damage to the steel retainer rail assemblies or metalized coating and are adjustable to account for variable temperature settings. Place supports near field splices of steel retainer rails to ensure that splices are straight and even.
- The proposed procedure to correct for the effects of beam movement and rotation when setting width of joint opening.
- The proposed installation procedure including the sequence and suggested direction of the concrete pour(s).
- The proposed mechanism to allow joint translation after the deck pour.

ST-8

- A section through the joint detail showing horizontal offset dimensions of the steel retainer rails from the centerline of the joint. This detail is required when the vertical face of the joint opening is not perpendicular to the roadway surface (e.g. when the roadway grade is significant).

4.0 FABRICATION

Fabricate the strip seal joint components in accordance with the approved shop drawings and the plans.

Splice sections of steel retainer rail in the shop to obtain required lengths. Do not use short pieces of steel retainer rail less than 6 feet 0 inches long unless required at curbs, sidewalks or staged construction locations. Splices in an individual steel retainer rail are only permitted where a construction joint is specifically required by the plans, joint segment length exceeds 50 feet, or approved by the Engineer in writing.

At splice locations where changes in deck slab cross slope occur, cut the ends of steel retainer rails parallel to the bridge centerline for skews less than 80° and greater than 100°.

Provide a neoprene gland that is compatible with the steel retainer rail. Produce a single continuous neoprene gland for the entire length of the joint. When necessary, only vulcanized splicing of the gland in the shop is permitted. Ensure the convolution(s) of the gland does not project above the top of the steel retainer rails when the ambient temperature results in the minimum joint opening.

5.0 SHIPMENT

Bolt the steel retainer rails together in the shop to form matching pairs. Clearly mark each pair to identify where they are to be placed. Ship the neoprene gland(s) together with the steel retainer rail(s) and clearly mark them to identify where they are to be placed.

6.0 INSTALLATION

Install the strip seal expansion joint in accordance with the plan details, this Special Provision, the Standard Specifications, and the manufacturer's recommended installation procedures. Have a manufacturer's representative present during installation of the joint.

Install the steel retainer rail assemblies at proper grade and alignment. See contract drawings for width of joint opening.

Bolt, weld or clamp steel retainer rail assemblies in position using temporary or sacrificial brackets as required. Do not use temporary or sacrificial support brackets, bolts, clamps, etc. between the faces of the steel retainer rails. Do not weld within 2 inches of steel retainer rail surfaces exposed in the completed structure. Do not weld strip seal expansion joint components to reinforcing steel or structural steel.

For staged construction, install steel retainer rail assemblies in a given subsequent stage to align with those installed in an adjacent prior stage after deflection and rotation due to deck casting of adjoining spans has occurred.

ST-9

Protect metalized steel retainer rail assemblies during screeding operations per the manufacturer's recommendations. Provide temporary blocking material in the steel retainer rail seal cavities to prevent concrete intrusion during deck pour and finishing.

Loosen any temporary or sacrificial support brackets, bolts, clamps, etc. that span across the joint after initial set of concrete, but not more than two hours after conclusion of concrete placement.

Install the neoprene gland after completion of deck casting. Use a single continuous neoprene gland for the entire length of the joint. Field splicing of the neoprene gland is not permitted. Remove all joint form material and blocking material prior to installing the gland. Field install the gland in accordance with manufacturer's recommendations. Thoroughly coat all contact surfaces between the gland and the steel retainer rail seal cavities with an adhesive lubricant before setting the gland in place. Use lubricant adhesive that conforms to ASTM D4070 and is compatible with manufacture's strip seal expansion joint to attach neoprene gland to the steel retainer rails.

7.0 INSPECTION

The Engineer inspects the joint system for proper alignment and proper stud placement and attachment. If any aspect of the strip seal expansion joint is deemed unacceptable, make the necessary corrections.

When concrete is cast, use a non-aluminum, 10 foot, true-to-line straight-edge to check and grade the top of the slab on each side of the joint to ensure smooth transition between spans.

Watertight Integrity Test

- Upon completion of each strip seal expansion joint, perform a watertight integrity test on the top surface to detect any leakage. Cover the roadway section of the joint from curb to curb, or barrier rail to barrier rail, with water, either ponded or flowing, not less than 1 inch above the roadway surface at all points. Block sidewalk sections and secure an unnozzled water hose delivering approximately 1 gallon of water per minute to the inside face of the bridge railing, trained in a downward position about 6 inches above the sidewalk, such that there is continuous flow of water across the sidewalk and down the curb face of the joint.
- Maintain the ponding or flowing of water on the roadway and continuous flow across sidewalks and curbs for a period of 5 hours. At the conclusion of the test, the underside of the joint is closely examined for leakage. The strip seal expansion joint is considered watertight if no obvious wetness is visible on the Engineer's finger after touching a number of underdeck areas. Damp concrete that does not impart wetness to the finger is not considered a sign of leakage.
- If the joint system leaks, locate the place(s) of leakage and take any repair measures necessary to stop the leakage at no additional cost to the Department. Use repair measures recommended by the manufacturer and approved by the Engineer prior to beginning corrective work.

ST-10

- If measures to eliminate leakage are taken, perform a subsequent watertight integrity test subject to the same conditions as the original test. Subsequent tests carry the same responsibility as the original test and are performed at no additional cost to the Department.

8.0 BASIS OF PAYMENT

Basis of payment for all strip seal expansion joints will be at the lump sum contract price for "Strip Seal Expansion Joints." Payment will be full compensation for furnishing all material, including any steel accessory plates for sidewalks, medians and rails, labor, tools, and incidentals necessary for installing the strip seal expansion joint in place and including all materials, labor, tools and incidentals for performing the original watertight integrity test.

ST-11

FALSEWORK AND FORMWORK

(2-14-22)

1.0 DESCRIPTION

Use this Special Provision as a guide to develop temporary works submittals required by the Standard Specifications or other provisions; no additional submittals are required herein. Such temporary works include, but are not limited to, falsework and formwork.

Falsework is any temporary construction used to support the permanent structure until it becomes self-supporting. Formwork is the temporary structure or mold used to retain plastic or fluid concrete in its designated shape until it hardens. Access scaffolding is a temporary structure that functions as a work platform that supports construction personnel, materials, and tools, but is not intended to support the structure. Scaffolding systems that are used to temporarily support permanent structures (as opposed to functioning as work platforms) are considered to be falsework under the definitions given. Shoring is a component of falsework such as horizontal, vertical, or inclined support members. Where the term “temporary works” is used, it includes all of the temporary facilities used in bridge construction that do not become part of the permanent structure.

Design and construct safe and adequate temporary works that will support all loads imposed and provide the necessary rigidity to achieve the lines and grades shown on the plans in the final structure.

2.0 MATERIALS

Select materials suitable for temporary works; however, select materials that also ensure the safety and quality required by the design assumptions. The Engineer has authority to reject material on the basis of its condition, inappropriate use, safety, or nonconformance with the plans. Clearly identify allowable loads or stresses for all materials or manufactured devices on the plans. Revise the plan and notify the Engineer if any change to materials or material strengths is required.

3.0 DESIGN REQUIREMENTS

A. Working Drawings

Provide working drawings for items as specified in the contract, or as required by the Engineer, with design calculations and supporting data in sufficient detail to permit a structural and safety review of the proposed design of the temporary work.

On the drawings, show all information necessary to allow the design of any component to be checked independently as determined by the Engineer.

When concrete placement is involved, include data such as the drawings of proposed sequence, rate of placement, direction of placement, and location of all construction joints.

ST-12

When required, have the drawings and calculations prepared under the guidance of, and sealed by, a North Carolina Registered Professional Engineer who is knowledgeable in temporary works design.

If requested by the Engineer, submit with the working drawings manufacturer's catalog data listing the weight of all construction equipment that will be supported on the temporary work. Show anticipated total settlements and/or deflections of falsework and forms on the working drawings. Include falsework footing settlements, joint take-up, and deflection of beams or girders.

As an option for the Contractor, overhang falsework hangers may be uniformly spaced, at a maximum of 36 inches, provided the following conditions are met:

Member Type (PCG)	Member Depth, (inches)	Max. Overhang Width, (inches)	Max. Slab Edge Thickness, (inches)	Max. Screenshot Wheel Weight, (lbs.)	Bracket Min. Vertical Leg Extension, (inches)
II	36	39	14	2000	26
III	45	42	14	2000	35
IV	54	45	14	2000	44
MBT	63	51	12	2000	50
MBT	72	55	12	1700	48

Overhang width is measured from the centerline of the girder to the edge of the deck slab. For Type II, III & IV prestressed concrete girders (PCG), 45-degree cast-in-place half hangers and rods must have a minimum safe working load of 6,000 lbs.

For MBT prestressed concrete girders, 45-degree angle holes for falsework hanger rods shall be cast through the girder top flange and located, measuring along the top of the member, 1'-2 1/2" from the edge of the top flange. Hanger hardware and rods must have a minimum safe working load of 6,000 lbs.

For links slabs, the tops of girders directly beneath the link slab shall be free of overhang falsework attachments or other hardware. Submit calculations and working drawings for overhang falsework in the link slab region.

The overhang bracket provided for the diagonal leg shall have a minimum safe working load of 3,750 lbs. The vertical leg of the bracket shall extend to the point that the heel bears on the girder bottom flange, no closer than 4 inches from the bottom of the member. However, for 72-inch members, the heel of the bracket shall bear on the web, near the bottom flange transition.

Provide adequate overhang falsework and determine the appropriate adjustments for deck geometry, equipment, casting procedures and casting conditions.

ST-13

If the optional overhang falsework spacing is used, indicate this on the falsework submittal and advise the girder producer of the proposed details. Failure to notify the Engineer of hanger type and hanger spacing on prestressed concrete girder casting drawings may delay the approval of those drawings.

Falsework hangers that support concentrated loads and are installed at the edge of thin top flange concrete girders (such as bulb tee girders) shall be spaced so as not to exceed 75% of the manufacturer's stated safe working load. Use of dual leg hangers (such as Meadow Burke HF-42 and HF-43) are not allowed on concrete girders with thin top flanges. Design the falsework and forms supporting deck slabs and overhangs on girder bridges so that there will be no differential settlement between the girders and the deck forms during placement of deck concrete.

When staged construction of the bridge deck is required, detail falsework and forms for screed and fluid concrete loads to be independent of any previous deck pour components when the mid-span girder deflection due to deck weight is greater than $\frac{3}{4}$ ".

Note on the working drawings any anchorages, connectors, inserts, steel sleeves or other such devices used as part of the falsework or formwork that remains in the permanent structure. If the plan notes indicate that the structure contains the necessary corrosion protection required for a Corrosive Site, epoxy coat, galvanize or metalize these devices. Electroplating will not be allowed. Any coating required by the Engineer will be considered incidental to the various pay items requiring temporary works.

Design falsework and formwork requiring submittals in accordance with the 1995 AASHTO *Guide Design Specifications for Bridge Temporary Works* except as noted herein.

1. Wind Loads

Table 2.2 of Article 2.2.5.1 is modified to include wind velocities up to 110 mph. In addition, Table 2.2A is included to provide the maximum wind speeds by county in North Carolina.

Table 2.2 - Wind Pressure Values

Height Zone feet above ground	Pressure, lb/ft ² for Indicated Wind Velocity, mph				
	70	80	90	100	110
0 to 30	15	20	25	30	35
30 to 50	20	25	30	35	40
50 to 100	25	30	35	40	45
over 100	30	35	40	45	50

ST-14

2. Time of Removal

The following requirements replace those of Article 3.4.8.2.

Do not remove forms until the concrete has attained strengths required in Article 420-16 of the Standard Specifications and these Special Provisions.

Do not remove forms until the concrete has sufficient strength to prevent damage to the surface.

ST-15

Table 2.2A - Steady State Maximum Wind Speeds by Counties in North Carolina

COUNTY	25 YR (mph)	COUNTY	25 YR (mph)	COUNTY	25 YR (mph)
Alamance	70	Franklin	70	Pamlico	100
Alexander	70	Gaston	70	Pasquotank	100
Alleghany	70	Gates	90	Pender	100
Anson	70	Graham	80	Perquimans	100
Ashe	70	Granville	70	Person	70
Avery	70	Greene	80	Pitt	90
Beaufort	100	Guilford	70	Polk	80
Bertie	90	Halifax	80	Randolph	70
Bladen	90	Harnett	70	Richmond	70
Brunswick	100	Haywood	80	Robeson	80
Buncombe	80	Henderson	80	Rockingham	70
Burke	70	Hertford	90	Rowan	70
Cabarrus	70	Hoke	70	Rutherford	70
Caldwell	70	Hyde	110	Sampson	90
Camden	100	Iredell	70	Scotland	70
Carteret	110	Jackson	80	Stanley	70
Caswell	70	Johnston	80	Stokes	70
Catawba	70	Jones	100	Surry	70
Cherokee	80	Lee	70	Swain	80
Chatham	70	Lenoir	90	Transylvania	80
Chowan	90	Lincoln	70	Tyrell	100
Clay	80	Macon	80	Union	70
Cleveland	70	Madison	80	Vance	70
Columbus	90	Martin	90	Wake	70
Craven	100	McDowell	70	Warren	70
Cumberland	80	Mecklenburg	70	Washington	100
Currituck	100	Mitchell	70	Watauga	70
Dare	110	Montgomery	70	Wayne	80
Davidson	70	Moore	70	Wilkes	70
Davie	70	Nash	80	Wilson	80
Duplin	90	New Hanover	100	Yadkin	70
Durham	70	Northampton	80	Yancey	70
Edgecombe	80	Onslow	100		
Forsyth	70	Orange	70		

ST-16

B. Review and Approval

The Engineer is responsible for the review and approval of temporary works' drawings.

Submit the working drawings sufficiently in advance of proposed use to allow for their review, revision (if needed), and approval without delay to the work.

The time period for review of the working drawings does not begin until complete drawings and design calculations, when required, are received by the Engineer.

Do not start construction of any temporary work for which working drawings are required until the drawings have been approved. Such approval does not relieve the Contractor of the responsibility for the accuracy and adequacy of the working drawings.

2.0 CONSTRUCTION REQUIREMENTS

All requirements of Section 420 of the Standard Specifications apply.

Construct temporary works in conformance with the approved working drawings. Ensure that the quality of materials and workmanship employed is consistent with that assumed in the design of the temporary works. Do not weld falsework members to any portion of the permanent structure unless approved. Show any welding to the permanent structure on the approved construction drawings.

Provide tell-tales attached to the forms and extending to the ground, or other means, for accurate measurement of falsework settlement. Make sure that the anticipated compressive settlement and/or deflection of falsework does not exceed 1 inch. For cast-in-place concrete structures, make sure that the calculated deflection of falsework flexural members does not exceed 1/240 of their span regardless of whether or not the deflection is compensated by camber strips.

A. Maintenance and Inspection

Inspect and maintain the temporary work in an acceptable condition throughout the period of its use. Certify that the manufactured devices have been maintained in a condition to allow them to safely carry their rated loads. Clearly mark each piece so that its capacity can be readily determined at the job site.

Perform an in-depth inspection of an applicable portion(s) of the temporary works, in the presence of the Engineer, not more than 24 hours prior to the beginning of each concrete placement. Inspect other temporary works at least once a month to ensure that they are functioning properly. Have a North Carolina Registered Professional Engineer inspect the cofferdams, shoring, sheathing, support of excavation structures, and support systems for load tests prior to loading.

ST-17

B. Foundations

Determine the safe bearing capacity of the foundation material on which the supports for temporary works rest. If required by the Engineer, conduct load tests to verify proposed bearing capacity values that are marginal or in other high-risk situations.

The use of the foundation support values shown on the contract plans of the permanent structure is permitted if the foundations are on the same level and on the same soil as those of the permanent structure.

Allow for adequate site drainage or soil protection to prevent soil saturation and washout of the soil supporting the temporary works supports.

If piles are used, the estimation of capacities and later confirmation during construction using standard procedures based on the driving characteristics of the pile is permitted. If preferred, use load tests to confirm the estimated capacities; or, if required by the Engineer conduct load tests to verify bearing capacity values that are marginal or in other high risk situations.

The Engineer reviews and approves the proposed pile and soil bearing capacities.

3.0 REMOVAL

Unless otherwise permitted, remove and keep all temporary works upon completion of the work. Do not disturb or otherwise damage the finished work.

Remove temporary works in conformance with the contract documents. Remove them in such a manner as to permit the structure to uniformly and gradually take the stresses due to its own weight.

4.0 METHOD OF MEASUREMENT

Unless otherwise specified, temporary works will not be directly measured.

5.0 BASIS OF PAYMENT

Payment at the contract unit prices for the various pay items requiring temporary works will be full compensation for the above falsework and formwork.

ST-18

SUBMITTAL OF WORKING DRAWINGS

(2-14-22)

1.0 GENERAL

Submit working drawings in accordance with Article 105-2 of the *Standard Specifications* and this provision. For this provision, “submittals” refers to only those listed in this provision. The list of submittals contained herein does not represent a list of required submittals for the project. Submittals are only necessary for those items as required by the contract. Make submittals that are not specifically noted in this provision directly to the Engineer. Either the Structures Management Unit or the Geotechnical Engineering Unit or both units will jointly review submittals.

If a submittal contains variations from plan details or specifications or significantly affects project cost, field construction or operations, discuss the submittal with and submit all copies to the Engineer. State the reason for the proposed variation in the submittal. To minimize review time, make sure all submittals are complete when initially submitted. Provide a contact name and information with each submittal. Direct any questions regarding submittal requirements to the Engineer, Structures Management Unit contacts or the Geotechnical Engineering Unit contacts noted below.

To facilitate in-plant inspection by NCDOT and approval of working drawings, provide the name, address and telephone number of the facility where fabrication will actually be done if different than shown on the title block of the submitted working drawings. This includes, but is not limited to, precast concrete items, prestressed concrete items and fabricated steel or aluminum items.

2.0 ADDRESSES AND CONTACTS

For submittals to the Structures Management Unit, use the following addresses:

Via Email: SMU-wdr@ncdot.gov (do not cc SMU Working Drawings staff)

Via US mail:

Mr. B. C. Hanks, P. E.
State Structures Engineer
North Carolina Department
of Transportation
Structures Management Unit
1581 Mail Service Center
Raleigh, NC 27699-1581

Attention: Mr. J. L. Bolden, P. E.

Via other delivery service:

Mr. B. C. Hanks, P. E.
State Structures Engineer
North Carolina Department
of Transportation
Structures Management Unit
1000 Birch Ridge Drive
Raleigh, NC 27610

Attention: Mr. J. L. Bolden, P. E.

For submittals to the Geotechnical Engineering Unit, use the following addresses:

For projects in Divisions 1-7, use the following Eastern Regional Office addresses:

ST-19

Via Email: EastGeotechnicalSubmittal@ncdot.gov

Via US mail:

Mr. David Hering, L.G., P. E.
Assistant State Geotechnical
Engineer – Eastern Region
North Carolina Department
of Transportation
Geotechnical Engineering Unit
Eastern Regional Office
1570 Mail Service Center
Raleigh, NC 27699-1570

Via other delivery service:

Mr. David Hering, L.G., P. E.
Assistant State Geotechnical
Engineer – Eastern Region
North Carolina Department
of Transportation
Geotechnical Engineering Unit
Eastern Regional Office
3301 Jones Sausage Road, Suite 100
Garner, NC 27529

For projects in Divisions 8-14, use the following Western Regional Office addresses:

Via Email: WestGeotechnicalSubmittal@ncdot.gov

Via US mail or other delivery service:

Mr. Eric Williams, P. E.
Assistant State Geotechnical
Engineer – Western Region
North Carolina Department
of Transportation
Geotechnical Engineering Unit
Western Regional Office
5253 Z Max Boulevard
Harrisburg, NC 28075

The status of the review of structure-related submittals sent to the Structures Management Unit can be viewed from the Unit's website, via the "[Drawing Submittal Status](#)" link.

The status of the review of geotechnical-related submittals sent to the Geotechnical Engineering Unit can be viewed from the Unit's website, via the "[Geotechnical Construction Submittals](#)" link.

Direct any questions concerning submittal review status, review comments or drawing markups to the following contacts:

Primary Structures Contact:

James Bolden (919) 707 – 6408
jlbolden@ncdot.gov

Secondary Structures Contacts:

Emmanuel Omile (919) 707 – 6451
eomile@ncdot.gov

Madonna Rorie (919) 707 – 6508
mrorie@ncdot.gov

ST-20

Eastern Regional Geotechnical Contact (Divisions 1-7):

David Hering (919) 662 – 4710
dthering@ncdot.gov

Western Regional Geotechnical Contact (Divisions 8-14):

Eric Williams (704) 455 – 8902
ewilliams3@ncdot.gov

3.0 SUBMITTAL COPIES

Furnish one complete copy of each submittal, including all attachments, to the Engineer. At the same time, submit a copy of the same complete submittal directly to the Structures Management Unit and/or the Geotechnical Engineering Unit as specified in the tables below.

The first table below covers “Structure Submittals.” The Engineer will receive review comments and drawing markups for these submittals from the Structures Management Unit. The second table in this section covers “Geotechnical Submittals.” The Engineer will receive review comments and drawing markups for these submittals from the Geotechnical Engineering Unit.

Unless otherwise required, submit one set of supporting calculations to either the Structures Management Unit or the Geotechnical Engineering Unit unless both units require submittal copies in which case submit a set of supporting calculations to each unit. Provide additional copies of any submittal as directed.

STRUCTURE SUBMITTALS

Submittal	Submittal Required by Structures Management Unit?	Submittal Required by Geotechnical Engineering Unit?	Contract Reference Requiring Submittal ¹
Arch Culvert Falsework	Y	N	Plan Note, SN Sheet & “Falsework and Formwork”
Box Culvert Falsework ⁷	Y	N	Plan Note, SN Sheet & “Falsework and Formwork”
Cofferdams	Y	Y	Article 410-4
Foam Joint Seals ⁶	Y	N	“Foam Joint Seals”
Expansion Joint Seals (hold down plate type with base angle)	Y	N	“Expansion Joint Seals”
Expansion Joint Seals	Y	N	“Modular Expansion Joint

ST-21

(modular)			Seals”
Expansion Joint Seals (strip seals)	Y	N	“Strip Seal Expansion Joints”
Falsework & Forms ² (substructure)	Y	N	Article 420-3 & “Falsework and Formwork”
Falsework & Forms (superstructure)	Y	N	Article 420-3 & “Falsework and Formwork”
Girder Erection over Railroad	Y	N	Railroad Provisions
Maintenance and Protection of Traffic Beneath Proposed Structure	Y	N	“Maintenance and Protection of Traffic Beneath Proposed Structure at Station ____”
Metal Bridge Railing	Y	N	Plan Note
Metal Stay-in-Place Forms	Y	N	Article 420-3
Metalwork for Elastomeric Bearings ^{4,5}	Y	N	Article 1072-8
Miscellaneous Metalwork ^{4,5}	Y	N	Article 1072-8
Disc Bearings ⁴	Y	N	“Disc Bearings”
Overhead and Digital Message Signs (DMS) (metalwork and foundations)	Y	N	Applicable Provisions
Placement of Equipment on Structures (cranes, etc.)	Y	N	Article 420-20
Prestressed Concrete Box Beam (detensioning sequences) ³	Y	N	Article 1078-11
Precast Concrete Box Culverts	Y	N	“Optional Precast Reinforced Concrete Box Culvert at Station ____”
Prestressed Concrete Cored Slab (detensioning sequences) ³	Y	N	Article 1078-11
Prestressed Concrete Deck Panels	Y	N	Article 420-3
Prestressed Concrete Girder (strand elongation and detensioning sequences)	Y	N	Articles 1078-8 and 1078- 11
Removal of Existing Structure over Railroad	Y	N	Railroad Provisions

ST-22

Revised Bridge Deck Plans (adaptation to prestressed deck panels)	Y	N	Article 420-3
Revised Bridge Deck Plans (adaptation to modular expansion joint seals)	Y	N	“Modular Expansion Joint Seals”
Sound Barrier Wall (precast items)	Y	N	Article 1077-2 & “Sound Barrier Wall”
Sound Barrier Wall Steel Fabrication Plans ⁵	Y	N	Article 1072-8 & “Sound Barrier Wall”
Structural Steel ⁴	Y	N	Article 1072-8
Temporary Detour Structures	Y	Y	Article 400-3 & “Construction, Maintenance and Removal of Temporary Structure at Station _____”
TFE Expansion Bearings ⁴	Y	N	Article 1072-8

FOOTNOTES

- References are provided to help locate the part of the contract where the submittals are required. References in quotes refer to the provision by that name. Articles refer to the *Standard Specifications*.
- Submittals for these items are necessary only when required by a note on plans.
- Submittals for these items may not be required. A list of pre-approved sequences is available from the producer or the Materials & Tests Unit.
- The fabricator may submit these items directly to the Structures Management Unit.
- The two sets of preliminary submittals required by Article 1072-8 of the *Standard Specifications* are not required for these items.
- Submittals for Fabrication Drawings are not required. Submittals for Catalogue Cuts of Proposed Material are required. See Section 5.A of the referenced provision.
- Submittals are necessary only when the top slab thickness is 18” or greater.

ST-23

GEOTECHNICAL SUBMITTALS

Submittal	Submittals Required by Geotechnical Engineering Unit	Submittals Required by Structures Management Unit	Contract Reference Requiring Submittal ¹
Drilled Pier Construction Plans ²	Y	N	Subarticle 411-3(A)
Crosshole Sonic Logging (CSL) Reports ²	Y	N	Subarticle 411-5(A)(2)
Pile Driving Equipment Data Forms ^{2,3}	Y	N	Subarticle 450-3(D)(2)
Pile Driving Analyzer (PDA) Reports ²	Y	N	Subarticle 450-3(F)(3)
Retaining Walls ⁴	Y; drawings and calculations	Y; drawings	Applicable Provisions
Temporary Shoring ⁴	Y; drawings and calculations	Y; drawings	“Temporary Shoring” & “Temporary Soil Nail Walls”

FOOTNOTES

- References are provided to help locate the part of the contract where the submittals are required. References in quotes refer to the provision by that name. Subarticles refer to the *Standard Specifications*.
- Submit one hard copy of submittal to the Engineer. Submit a second copy of submittal electronically (PDF via email), US mail or other delivery service to the appropriate Geotechnical Engineering Unit regional office. Electronic submission is preferred.
- The Pile Driving Equipment Data Form is available from:
https://connect.ncdot.gov/resources/Geological/Pages/Geotech_Forms_Details.aspx
See second page of form for submittal instructions.
- Electronic copy of submittal is required. See referenced provision.

ST-24

CRANE SAFETY**(6-20-19)**

Comply with the manufacturer specifications and limitations applicable to the operation of any and all cranes and derricks. Prime contractors, sub-contractors, and fully operated rental companies shall comply with the current Occupational Safety and Health Administration (OSHA) regulations.

Submit all items listed below to the Engineer prior to beginning crane operations. Changes in personnel or equipment must be reported to the Engineer and all applicable items listed below must be updated and submitted prior to continuing with crane operations.

CRANE SAFETY SUBMITTAL LIST

Competent Person: Provide the name and qualifications of the “Competent Person” responsible for crane safety and lifting operations. The named competent person will have the responsibility and authority to stop any work activity due to safety concerns.

Riggers: Provide the qualifications and experience of the persons responsible for rigging operations. Qualifications and experience should include, but not be limited to, weight calculations, center of gravity determinations, selection and inspection of sling and rigging equipment, and safe rigging practices.

Crane Inspections: Inspection records for all cranes shall be current and readily accessible for review upon request.

Certifications: Crane operators shall be certified by the National Commission for the Certification of Crane Operators (NCCCO) or the National Center for Construction Education and Research (NCCER). Other approved nationally accredited programs will be considered upon request. In addition, crane operators shall have a current CDL medical card. Submit a list of crane operator(s) and include current certification for each type of crane operated (small hydraulic, large hydraulic, small lattice, large lattice) and medical evaluations for each operator.

ST-25

GROUT FOR STRUCTURES

(12-1-17)

1.0 DESCRIPTION

This special provision addresses grout for use in pile blockouts, grout pockets, shear keys, dowel holes and recesses for structures. This provision does not apply to grout placed in post-tensioning ducts for bridge beams, girders, decks, end bent caps, or bent caps. Mix and place grout in accordance with the manufacturer's recommendations, the applicable sections of the Standard Specifications and this provision.

2.0 MATERIAL REQUIREMENTS

Unless otherwise noted on the plans, use a Type 3 Grout in accordance with Section 1003 of the Standard Specifications.

Initial setting time shall not be less than 10 minutes when tested in accordance with ASTM C266.

Construction loading and traffic loading shall not be allowed until the 3 day compressive strength is achieved.

3.0 SAMPLING AND PLACEMENT

Place and maintain components in final position until grout placement is complete and accepted. Concrete surfaces to receive grout shall be free of defective concrete, laitance, oil, grease and other foreign matter. Saturate concrete surfaces with clean water and remove excess water prior to placing grout.

4.0 BASIS OF PAYMENT

No separate payment will be made for "Grout for Structures". The cost of the material, equipment, labor, placement, and any incidentals necessary to complete the work shall be considered incidental to the structure item requiring grout.

ST-26

ASBESTOS ASSESSMENT FOR BRIDGE DEMOLITION AND RENOVATION ACTIVITIES

(12-30-15)

1.0 INSPECTION FOR ASBESTOS CONTAINING MATERIAL

Prior to conducting bridge demolition or renovation activities, the Contractor shall thoroughly inspect the bridge or affected components for the presence of asbestos containing material (ACM) using a firm prequalified by NCDOT to perform asbestos surveys. The inspection must be performed by a N.C. accredited asbestos inspector with experience inspecting bridges or other industrial structures. The N.C. accredited asbestos inspector must conduct a thorough inspection, identifying all asbestos-containing material as required by the Environmental Protection Agency National Emission Standards for Hazardous Air Pollutants (NESHAP) Code of Federal Regulations (CFR) 40 CFR, Part 61, Subpart M.

The Contractor shall submit an inspection report to the Engineer, which at a minimum must include information required in 40 CFR 763.85 (a)(4) vi)(A)-(E), as well as a project location map, photos of existing structure, the date of inspection and the name, N.C. accreditation number, and signature of the N.C. accredited asbestos inspector who performed the inspection and completed the report. The cover sheet of the report shall include project identification information. Place the following notes on the cover sheet of the report and check the appropriate box:

- ACM was found
 ACM was not found

2.0 REMOVAL AND DISPOSAL OF ASBESTOS CONTAINING MATERIAL

If ACM is found, notify the Engineer. Compensation for removal and disposal of ACM is considered extra work in accordance with Article 104-7 of the Standard Specifications.

An Asbestos Removal Permit must be obtained from the Health Hazards Control Unit (HHCU) of the N.C. Department of Health & Human Services, Division of Public Health, if more than 35 cubic feet, 160 square feet, or 260 linear feet of regulated ACM (RACM) is to be removed from a structure and this work must be completed by a contractor prequalified by NCDOT to perform asbestos abatement. RACM is defined in 40 CFR, Part 61, Subpart M. Note: 40 CFR 763.85 (a)(4) vi)(D) defines ACM as surfacing, TSI and Miscellaneous which does not meet the NESHAP RACM.

3.0 DEMOLITION NOTIFICATION

Even if no ACM is found (or if quantities are less than those required for a permit), a Demolition Notification (DHHS-3768) must be submitted to the HHCU. Notifications and Asbestos Permit applications require an original signature and must be submitted to the HHCU 10 working days prior to beginning demolition activities. The 10 working day period starts based on the post-marked date or date of hand delivery. Demolition that does not begin as originally notified requires submission of a separate revision form HHCU

ST-27

3768-R to HHCU. Reference the North Carolina Administrative Code, Chapter 10A, Subchapter 41C, Article .0605 for directives on revision submissions.

Contact Information

Health Hazards Control Unit (HHCU)
N.C. Department of Health and Human Services
1912 Mail Service Center
Raleigh, NC 27699-1912
Telephone: (919) 707-5950
Fax: (919) 870-4808

4.0 SPECIAL CONSIDERATIONS

Buncombe, Forsyth, and Mecklenburg counties also have asbestos permitting and NESHAP requirements must be followed. For projects involving permitted RACM removals, both the applicable county and the state (HHCU) must be notified.

For demolitions with no RACM, only the local environmental agencies must be notified. Contact information is as follows:

Buncombe County

WNC Regional Air Pollution Control Agency
49 Mt. Carmel Road
Asheville, NC 28806
(828) 250-6777

Forsyth County

Environmental Affairs Department
537 N. Spruce Street
Winston-Salem, NC 27101
(336) 703-2440

Mecklenburg County

Land Use and Environmental Services Agency
Mecklenburg Air Quality
700 N. Tryon Street
Charlotte, NC 28202
(704) 336-5430

5.0 ADDITIONAL INFORMATION

Additional information may be found on N.C. asbestos rules, regulations, procedures and N.C. accredited inspectors, as well as associated forms for demolition notifications and asbestos permit applications at the N.C. Asbestos Hazard Management Program website:

<https://epi.dph.ncdhhs.gov/asbestos/ahmp.html>

ST-28

6.0 BASIS OF PAYMENT

Payment for the work required in this provision will be at the lump sum contract unit price for "Asbestos Assessment". Such payment will be full compensation for all asbestos inspections, reports, permitting and notifications.

County: FORSYTH

Line #	Item Number	Sec #	Description	Quantity	Unit Cost	Amount
ROADWAY ITEMS						
0001	0000100000-N	800	MOBILIZATION	Lump Sum	L.S.	
0002	0000400000-N	801	CONSTRUCTION SURVEYING	Lump Sum	L.S.	
0003	0008000000-E	200	SUPPLEMENTARY CLEARING & GRUBBING	1 ACR		
0004	0015000000-N	205	SEALING ABANDONED WELLS	2 EA		
0005	0029000000-N	SP	TYPE III REINFORCED APPROACH FILL, STATION ***** (33+99.11 -L-)	Lump Sum	L.S.	
0006	0043000000-N	226	GRADING	Lump Sum	L.S.	
0007	0057000000-E	226	UNDERCUT EXCAVATION	450 CY		
0008	0134000000-E	240	DRAINAGE DITCH EXCAVATION	290 CY		
0009	0194000000-E	265	SELECT GRANULAR MATERIAL, CLASS III	400 CY		
0010	0196000000-E	270	GEOTEXTILE FOR SOIL STABILIZATION	500 SY		
0011	0199000000-E	SP	TEMPORARY SHORING	6,232 SF		
0012	0318000000-E	300	FOUNDATION CONDITIONING MATERIAL, MINOR STRUCTURES	735 TON		
0013	0320000000-E	300	FOUNDATION CONDITIONING GEOTEXTILE	2,300 SY		
0014	0448200000-E	310	15" RC PIPE CULVERTS, CLASS IV	1,024 LF		
0015	0448300000-E	310	18" RC PIPE CULVERTS, CLASS IV	3,746 LF		
0016	0448400000-E	310	24" RC PIPE CULVERTS, CLASS IV	988 LF		
0017	0448500000-E	310	30" RC PIPE CULVERTS, CLASS IV	80 LF		

County: FORSYTH

Line #	Item Number	Sec #	Description	Quantity	Unit Cost	Amount
0018	0448600000-E	310	36" RC PIPE CULVERTS, CLASS IV	16 LF		
0019	0448700000-E	310	42" RC PIPE CULVERTS, CLASS IV	288 LF		
0020	0582000000-E	310	15" CS PIPE CULVERTS, 0.064" THICK	164 LF		
0021	0588000000-E	310	18" CS PIPE CULVERTS, 0.064" THICK	220 LF		
0022	0594000000-E	310	24" CS PIPE CULVERTS, 0.064" THICK	44 LF		
0023	0636000000-E	310	*** CS PIPE ELBOWS, ***** THICK (15", 0.064")	10 EA		
0024	0636000000-E	310	*** CS PIPE ELBOWS, ***** THICK (18", 0.064")	6 EA		
0025	0636000000-E	310	*** CS PIPE ELBOWS, ***** THICK (24", 0.064")	2 EA		
0026	0995000000-E	340	PIPE REMOVAL	4,135 LF		
0027	1004500000-E	505	GENERIC GRADING ITEM GEOTEXTILE FOR SUBGRADE STABILIZATION	7,200 SY		
0028	1099500000-E	505	SHALLOW UNDERCUT	2,800 CY		
0029	1099700000-E	505	CLASS IV SUBGRADE STABILIZATION	6,600 TON		
0030	1220000000-E	545	INCIDENTAL STONE BASE	200 TON		
0031	1245000000-E	SP	SHOULDER RECONSTRUCTION	3.6 SMI		
0032	1260000000-E	SP	AGGREGATE SHOULDER BORROW	2,000 TON		
0033	1297000000-E	607	MILLING ASPHALT PAVEMENT, **** DEPTH (4")	2,340 SY		
0034	1297000000-E	607	MILLING ASPHALT PAVEMENT, **** DEPTH (6")	11,390 SY		

County: FORSYTH

Line #	Item Number	Sec #	Description	Quantity	Unit Cost	Amount
0035	1330000000-E	607	INCIDENTAL MILLING	26,850 SY		
0036	1491000000-E	610	ASPHALT CONC BASE COURSE, TYPE B25.0C	14,230 TON		
0037	1503000000-E	610	ASPHALT CONC INTERMEDIATE COURSE, TYPE I19.0C	10,320 TON		
0038	1519000000-E	610	ASPHALT CONC SURFACE COURSE, TYPE S9.5B	5,990 TON		
0039	1523000000-E	610	ASPHALT CONC SURFACE COURSE, TYPE S9.5C	960 TON		
0040	1575000000-E	620	ASPHALT BINDER FOR PLANT MIX	1,585 TON		
0041	1577000000-E	620	POLYMER MODIFIED ASPHALT BINDER FOR PLANT MIX	55 TON		
0042	1693000000-E	654	ASPHALT PLANT MIX, PAVEMENT REPAIR	800 TON		
0043	1839140000-E	661	ULTRA-THIN BONDED WEARING COURSE	1,010 TON		
0044	1840000000-E	665	MILLED RUMBLE STRIPS (ASPHALT CONCRETE)	14,760 LF		
0045	1891000000-E	SP	GENERIC PAVING ITEM FINE MILLING	28,650 SY		
0046	2000000000-N	806	RIGHT-OF-WAY MARKERS	70 EA		
0047	2022000000-E	815	SUBDRAIN EXCAVATION	44.8 CY		
0048	2026000000-E	815	GEOTEXTILE FOR SUBSURFACE DRAINS	200 SY		
0049	2036000000-E	815	SUBDRAIN COARSE AGGREGATE	33.6 CY		
0050	2044000000-E	815	6" PERFORATED SUBDRAIN PIPE	200 LF		
0051	2070000000-N	815	SUBDRAIN PIPE OUTLET	1 EA		

County: FORSYTH

Line #	Item Number	Sec #	Description	Quantity	Unit Cost	Amount
0052	2077000000-E	815	6" OUTLET PIPE	6 LF		
0053	2190000000-N	828	TEMPORARY STEEL PLATE COVERS FOR MASONRY DRAINAGE STRUCTURE	7 EA		
0054	2209000000-E	838	ENDWALLS	3.4 CY		
0055	2275000000-E	SP	FLOWABLE FILL	2 CY		
0056	2286000000-N	840	MASONRY DRAINAGE STRUCTURES	112 EA		
0057	2308000000-E	840	MASONRY DRAINAGE STRUCTURES	47.1 LF		
0058	2364000000-N	840	FRAME WITH TWO GRATES, STD 840.16	26 EA		
0059	2374000000-N	840	FRAME WITH GRATE & HOOD, STD 840.03, TYPE ** (E)	7 EA		
0060	2374000000-N	840	FRAME WITH GRATE & HOOD, STD 840.03, TYPE ** (F)	41 EA		
0061	2374000000-N	840	FRAME WITH GRATE & HOOD, STD 840.03, TYPE ** (G)	28 EA		
0062	2396000000-N	840	FRAME WITH COVER, STD 840.54	12 EA		
0063	2535000000-E	846	*** X *** CONCRETE CURB (8" X 12")	490 LF		
0064	2542000000-E	846	1'-6" CONCRETE CURB & GUTTER	1,120 LF		
0065	2549000000-E	846	2'-6" CONCRETE CURB & GUTTER	10,940 LF		
0066	2591000000-E	848	4" CONCRETE SIDEWALK	4,160 SY		
0067	2605000000-N	848	CONCRETE CURB RAMPS	45 EA		

County: FORSYTH

Line #	Item Number	Sec #	Description	Quantity	Unit Cost	Amount
0068	2612000000-E	848	6" CONCRETE DRIVEWAY	30 SY		
0069	2655000000-E	852	5" MONOLITHIC CONCRETE ISLANDS (KEYED IN)	4,620 SY		
0070	2724000000-E	857	PRECAST REINFORCED CONCRETE BARRIER, SINGLE FACED	425 LF		
0071	2738000000-E	SP	GENERIC PAVING ITEM 9" CONCRETE TRUCK APRON	630 SY		
0072	2753000000-E	846	GENERIC PAVING ITEM 2'-6" CONCRETE CURB AND GUTTER (MODIFIED)	240 LF		
0073	2753000000-E	846	GENERIC PAVING ITEM CONCRETE VALLEY GUTTER (MODIFIED)	360 LF		
0074	2830000000-N	858	ADJUSTMENT OF MANHOLES	17 EA		
0075	2845000000-N	858	ADJUSTMENT OF METER BOXES OR VALVE BOXES	10 EA		
0076	2950000000-N	859	CONVERT EXISTING JUNCTION BOX TO DROP INLET	1 EA		
0077	3030000000-E	862	STEEL BEAM GUARDRAIL	1,737.5 LF		
0078	3045000000-E	862	STEEL BEAM GUARDRAIL, SHOP CURVED	275 LF		
0079	3150000000-N	862	ADDITIONAL GUARDRAIL POSTS	5 EA		
0080	3195000000-N	862	GUARDRAIL END UNITS, TYPE AT-1	1 EA		
0081	3210000000-N	862	GUARDRAIL END UNITS, TYPE CAT-1	6 EA		
0082	3215000000-N	SP	GUARDRAIL ANCHOR UNITS, TYPE III	3 EA		
0083	3287000000-N	SP	GUARDRAIL END UNITS, TYPE TL-3	5 EA		
0084	3288000000-N	SP	GUARDRAIL END UNITS, TYPE TL-2	1 EA		

County: FORSYTH

Line #	Item Number	Sec #	Description	Quantity	Unit Cost	Amount
0085	3317000000-N	SP	GUARDRAIL ANCHOR UNITS, TYPE B-77	8 EA		
0086	3360000000-E	863	REMOVE EXISTING GUARDRAIL	1,404 LF		
0087	3533000000-E	866	CHAIN LINK FENCE, *** FABRIC (72")	300 LF		
0088	3539000000-E	866	METAL LINE POSTS FOR *** CHAIN LINK FENCE (72")	25 EA		
0089	3545000000-E	866	METAL TERMINAL POSTS FOR *** CHAIN LINK FENCE (72")	5 EA		
0090	3649000000-E	876	RIP RAP, CLASS B	325 TON		
0091	3656000000-E	876	GEOTEXTILE FOR DRAINAGE	2,330 SY		
0092	4048000000-E	902	REINFORCED CONCRETE SIGN FOUNDATIONS	4 CY		
0093	4054000000-E	902	PLAIN CONCRETE SIGN FOUNDATIONS	2 CY		
0094	4060000000-E	903	SUPPORTS, BREAKAWAY STEEL BEAM	3,114 LB		
0095	4066000000-E	903	SUPPORTS, SIMPLE STEEL BEAM	1,850 LB		
0096	4072000000-E	903	SUPPORTS, 3-LB STEEL U-CHANNEL	1,450 LF		
0097	4096000000-N	904	SIGN ERECTION, TYPE D	2 EA		
0098	4102000000-N	904	SIGN ERECTION, TYPE E	76 EA		
0099	4108000000-N	904	SIGN ERECTION, TYPE F	4 EA		
0100	4110000000-N	904	SIGN ERECTION, TYPE *** (GROUND MOUNTED) (A)	10 EA		

County: FORSYTH

Line #	Item Number	Sec #	Description	Quantity	Unit Cost	Amount
0101	4110000000-N	904	SIGN ERECTION, TYPE *** (GROUND MOUNTED) (B)	2 EA		
0102	4116100000-N	904	SIGN ERECTION, RELOCATE TYPE **** (GROUND MOUNTED) (A)	5 EA		
0103	4116100000-N	904	SIGN ERECTION, RELOCATE TYPE **** (GROUND MOUNTED) (B)	2 EA		
0104	4116100000-N	904	SIGN ERECTION, RELOCATE TYPE **** (GROUND MOUNTED) (E)	7 EA		
0105	4138000000-N	907	DISPOSAL OF SUPPORT, STEEL BEAM	7 EA		
0106	4152000000-N	907	DISPOSAL OF SIGN SYSTEM, STEEL BEAM	1 EA		
0107	4155000000-N	907	DISPOSAL OF SIGN SYSTEM, U-CHANNEL	50 EA		
0108	4192000000-N	907	DISPOSAL OF SUPPORT, U-CHANNEL	7 EA		
0109	4400000000-E	1110	WORK ZONE SIGNS (STATIONARY)	561 SF		
0110	4402000000-E	SP	HIGH VISIBILITY STATIONARY SIGNS	192 SF		
0111	4405000000-E	1110	WORK ZONE SIGNS (PORTABLE)	680 SF		
0112	4407000000-E	SP	HIGH VISIBILITY PORTABLE SIGNS	554 SF		
0113	4410000000-E	1110	WORK ZONE SIGNS (BARRICADE MOUNTED)	54 SF		
0114	4415000000-N	1115	FLASHING ARROW BOARD	5 EA		
0115	4420000000-N	1120	PORTABLE CHANGEABLE MESSAGE SIGN	4 EA		
0116	4430000000-N	1130	DRUMS	300 EA		

County: FORSYTH

Line #	Item Number	Sec #	Description	Quantity	Unit Cost	Amount
0117	4432000000-N	SP	HIGH VISIBILITY DRUMS	182 EA		
0118	4434000000-N	SP	SEQUENTIAL FLASHING WARNING LIGHTS	12 EA		
0119	4435000000-N	1135	CONES	100 EA		
0120	4445000000-E	1145	BARRICADES (TYPE III)	56 LF		
0121	4447000000-E	SP	PEDESTRIAN CHANNELIZING DEVICES	314 LF		
0122	4455000000-N	1150	FLAGGER	390 DAY		
0123	4465000000-N	1160	TEMPORARY CRASH CUSHIONS	9 EA		
0124	4470000000-N	1160	REMOVE & RESET TEMPORARY CRASH CUSHION	1 EA		
0125	4480000000-N	1165	TMA	2 EA		
0126	4485000000-E	1170	PORTABLE CONCRETE BARRIER	1,720 LF		
0127	4490000000-E	1170	PORTABLE CONCRETE BARRIER (ANCHORED)	200 LF		
0128	4505000000-E	1170	REMOVE & RESET PORTABLE CONCRETE BARRIER (ANCHORED)	550 LF		
0129	4510000000-N	1190	LAW ENFORCEMENT	240 HR		
0130	4600000000-N	SP	GENERIC TRAFFIC CONTROL ITEM AUDIBLE WARNING DEVICES	3 EA		
0131	4600000000-N	SP	GENERIC TRAFFIC CONTROL ITEM PEDESTRIAN TRANSPORT SERVICE (PER TRIP)	300 EA		
0132	4650000000-N	1251	TEMPORARY RAISED PAVEMENT MARKERS	840 EA		
0133	4685000000-E	1205	THERMOPLASTIC PAVEMENT MARKING LINES (4", 90 MILS)	18,388 LF		

County: FORSYTH

Line #	Item Number	Sec #	Description	Quantity	Unit Cost	Amount
0134	4688000000-E	1205	THERMOPLASTIC PAVEMENT MARKING LINES (6", 90 MILS)	25,350 LF		
0135	4695000000-E	1205	THERMOPLASTIC PAVEMENT MARKING LINES (8", 90 MILS)	4,240 LF		
0136	4700000000-E	1205	THERMOPLASTIC PAVEMENT MARKING LINES (12", 90 MILS)	1,860 LF		
0137	4709000000-E	1205	THERMOPLASTIC PAVEMENT MARKING LINES (24", 90 MILS)	1,950 LF		
0138	4720000000-E	1205	THERMOPLASTIC PAVEMENT MARKING CHARACTER (90 MILS)	12 EA		
0139	4725000000-E	1205	THERMOPLASTIC PAVEMENT MARKING SYMBOL (90 MILS)	109 EA		
0140	4770000000-E	1205	COLD APPLIED PLASTIC PAVEMENT MARKING LINES, TYPE ** (4") (II)	1,362 LF		
0141	4770000000-E	1205	COLD APPLIED PLASTIC PAVEMENT MARKING LINES, TYPE ** (4") (IV)	2,599 LF		
0142	4805000000-N	1205	COLD APPLIED PLASTIC PAVEMENT MARKING SYMBOL, TYPE ** (II)	4 EA		
0143	4805000000-N	1205	COLD APPLIED PLASTIC PAVEMENT MARKING SYMBOL, TYPE ** (IV)	3 EA		
0144	4810000000-E	1205	PAINT PAVEMENT MARKING LINES (4")	155,202 LF		
0145	4815000000-E	1205	PAINT PAVEMENT MARKING LINES (6")	35,352 LF		
0146	4820000000-E	1205	PAINT PAVEMENT MARKING LINES (8")	19,034 LF		
0147	4825000000-E	1205	PAINT PAVEMENT MARKING LINES (12")	2,120 LF		
0148	4835000000-E	1205	PAINT PAVEMENT MARKING LINES (24")	2,892 LF		
0149	4840000000-N	1205	PAINT PAVEMENT MARKING CHARACTER	28 EA		

County: FORSYTH

Line #	Item Number	Sec #	Description	Quantity	Unit Cost	Amount
0150	4845000000-N	1205	PAINT PAVEMENT MARKING SYMBOL	300 EA		
0151	4850000000-E	1205	REMOVAL OF PAVEMENT MARKING LINES (4")	48,050 LF		
0152	4855000000-E	1205	REMOVAL OF PAVEMENT MARKING LINES (6")	19,109 LF		
0153	4860000000-E	1205	REMOVAL OF PAVEMENT MARKING LINES (8")	2,105 LF		
0154	4865000000-E	1205	REMOVAL OF PAVEMENT MARKING LINES (12")	500 LF		
0155	4870000000-E	1205	REMOVAL OF PAVEMENT MARKING LINES (24")	915 LF		
0156	4875000000-N	1205	REMOVAL OF PAVEMENT MARKING SYMBOLS & CHARACTERS	173 EA		
0157	4900000000-N	1251	PERMANENT RAISED PAVEMENT MARKERS	25 EA		
0158	4905100000-N	SP	NON-CAST IRON SNOWPLOWABLE PAVEMENT MARKER	900 EA		
0159	5255000000-N	1413	PORTABLE LIGHTING	Lump Sum	L.S.	
0160	5325600000-E	1510	6" WATER LINE	184 LF		
0161	5326200000-E	1510	12" WATER LINE	270 LF		
0162	5326600000-E	1510	16" WATER LINE	353 LF		
0163	5329000000-E	1510	DUCTILE IRON WATER PIPE FITTINGS	10,695 LB		
0164	5540000000-E	1515	6" VALVE	4 EA		
0165	5558000000-E	1515	12" VALVE	2 EA		
0166	5558600000-E	1515	16" VALVE	1 EA		

County: FORSYTH

Line #	Item Number	Sec #	Description	Quantity	Unit Cost	Amount
0167	5648000000-N	1515	RELOCATE WATER METER	14 EA		
0168	5649000000-N	1515	RECONNECT WATER METER	3 EA		
0169	5656100000-E	1515	RELOCATE *** RPZ BACKFLOW PREVENTION ASSEMBLY (1")	4 EA		
0170	5656210000-E	1515	RELOCATE 2" RPZ BACKFLOW PREVENTION ASSEMBLY	1 EA		
0171	5666000000-N	1515	FIRE HYDRANT	3 EA		
0172	5672000000-N	1515	RELOCATE FIRE HYDRANT	2 EA		
0173	5673000000-E	1515	FIRE HYDRANT LEG	237 LF		
0174	5686500000-E	1515	WATER SERVICE LINE	827 LF		
0175	5691300000-E	1520	8" SANITARY GRAVITY SEWER	195 LF		
0176	5768000000-N	1520	SANITARY SEWER CLEAN-OUT	11 EA		
0177	5768500000-E	1520	SEWER SERVICE LINE	194 LF		
0178	5775000000-E	1525	4' DIA UTILITY MANHOLE	3 EA		
0179	5781000000-E	1525	UTILITY MANHOLE WALL 4' DIA	8 LF		
0180	5800000000-E	1530	ABANDON 6" UTILITY PIPE	714 LF		
0181	5801000000-E	1530	ABANDON 8" UTILITY PIPE	161 LF		
0182	5804000000-E	1530	ABANDON 12" UTILITY PIPE	260 LF		
0183	5816000000-N	1530	ABANDON UTILITY MANHOLE	3 EA		

County: FORSYTH

Line #	Item Number	Sec #	Description	Quantity	Unit Cost	Amount
0184	6000000000-E	1605	TEMPORARY SILT FENCE	14,035 LF		
0185	6006000000-E	1610	STONE FOR EROSION CONTROL, CLASS A	700 TON		
0186	6009000000-E	1610	STONE FOR EROSION CONTROL, CLASS B	1,360 TON		
0187	6012000000-E	1610	SEDIMENT CONTROL STONE	2,255 TON		
0188	6015000000-E	1615	TEMPORARY MULCHING	43 ACR		
0189	6018000000-E	1620	SEED FOR TEMPORARY SEEDING	2,100 LB		
0190	6021000000-E	1620	FERTILIZER FOR TEMPORARY SEEDING	12.5 TON		
0191	6024000000-E	1622	TEMPORARY SLOPE DRAINS	635 LF		
0192	6029000000-E	SP	SAFETY FENCE	1,600 LF		
0193	6030000000-E	1630	SILT EXCAVATION	4,270 CY		
0194	6036000000-E	1631	MATTING FOR EROSION CONTROL	20,800 SY		
0195	6037000000-E	SP	COIR FIBER MAT	40 SY		
0196	6038000000-E	SP	PERMANENT SOIL REINFORCEMENT MAT	75 SY		
0197	6042000000-E	1632	1/4" HARDWARE CLOTH	8,625 LF		
0198	6071012000-E	SP	COIR FIBER WATTLE	400 LF		
0199	6071020000-E	SP	POLYACRYLAMIDE (PAM)	115 LB		
0200	6071030000-E	1640	COIR FIBER BAFFLE	645 LF		

County: FORSYTH

Line #	Item Number	Sec #	Description	Quantity	Unit Cost	Amount
0201	6071050000-E	SP	*** SKIMMER (1-1/2")	2 EA		
0202	6071050000-E	SP	*** SKIMMER (2")	1 EA		
0203	6084000000-E	1660	SEEDING & MULCHING	33 ACR		
0204	6087000000-E	1660	MOWING	30 ACR		
0205	6090000000-E	1661	SEED FOR REPAIR SEEDING	450 LB		
0206	6093000000-E	1661	FERTILIZER FOR REPAIR SEEDING	1.25 TON		
0207	6096000000-E	1662	SEED FOR SUPPLEMENTAL SEEDING	775 LB		
0208	6108000000-E	1665	FERTILIZER TOPDRESSING	23.25 TON		
0209	6114500000-N	1667	SPECIALIZED HAND MOWING	10 MHR		
0210	6114800000-N	SP	MANUAL LITTER REMOVAL	17 MHR		
0211	6114900000-E	SP	LITTER DISPOSAL	2 TON		
0212	6117000000-N	SP	RESPONSE FOR EROSION CONTROL	100 EA		
0213	6117500000-N	SP	CONCRETE WASHOUT STRUCTURE	10 EA		
0214	6132000000-N	SP	GENERIC EROSION CONTROL ITEM FABRIC INSERT INLET PROTECTION DEVICE	108 EA		
0215	6132000000-N	SP	GENERIC EROSION CONTROL ITEM FABRIC INSERT INLET PROTECTION DEVICE CLEANOUT	324 EA		
0216	7048500000-E	1705	PEDESTRIAN SIGNAL HEAD (16", 1 SECTION W/COUNTDOWN)	20 EA		
0217	7060000000-E	1705	SIGNAL CABLE	9,225 LF		

County: FORSYTH

Line #	Item Number	Sec #	Description	Quantity	Unit Cost	Amount
0218	7120000000-E	1705	VEHICLE SIGNAL HEAD (12", 3 SECTION)	60 EA		
0219	7132000000-E	1705	VEHICLE SIGNAL HEAD (12", 4 SECTION)	9 EA		
0220	7144000000-E	1705	VEHICLE SIGNAL HEAD (12", 5 SECTION)	9 EA		
0221	7252000000-E	1710	MESSENGER CABLE (1/4")	3,375 LF		
0222	7264000000-E	1710	MESSENGER CABLE (3/8")	3,585 LF		
0223	7279000000-E	1715	TRACER WIRE	2,270 LF		
0224	7288000000-E	1715	PAVED TRENCHING (*****) (1, 2")	100 LF		
0225	7300000000-E	1715	UNPAVED TRENCHING (*****) (1, 2")	1,865 LF		
0226	7300000000-E	1715	UNPAVED TRENCHING (*****) (2, 2")	20 LF		
0227	7300000000-E	1715	UNPAVED TRENCHING (*****) (3, 2")	115 LF		
0228	7301000000-E	1715	DIRECTIONAL DRILL (*****) (1, 2")	405 LF		
0229	7301000000-E	1715	DIRECTIONAL DRILL (*****) (2, 2")	925 LF		
0230	7301000000-E	1715	DIRECTIONAL DRILL (*****) (3, 2")	1,050 LF		
0231	7312000000-N	1716	JUNCTION BOX (*****) (SPECIAL OVERSIZED, HEAVY DUTY, 36" X 24" X 24")	6 EA		
0232	7324000000-N	1716	JUNCTION BOX (STANDARD SIZE)	31 EA		
0233	7348000000-N	1716	JUNCTION BOX (OVER-SIZED, HEAVY DUTY)	13 EA		
0234	7360000000-N	1720	WOOD POLE	4 EA		

County: FORSYTH

Line #	Item Number	Sec #	Description	Quantity	Unit Cost	Amount
0235	7372000000-N	1721	GUY ASSEMBLY	33 EA		
0236	7396000000-E	1722	1/2" RISER WITH WEATHERHEAD	7 EA		
0237	7408000000-E	1722	1" RISER WITH WEATHERHEAD	5 EA		
0238	7420000000-E	1722	2" RISER WITH WEATHERHEAD	8 EA		
0239	7432000000-E	1722	2" RISER WITH HEAT SHRINK TUBING	12 EA		
0240	7444000000-E	1725	INDUCTIVE LOOP SAWCUT	5,475 LF		
0241	7456000000-E	1726	LEAD-IN CABLE (***** (14-2)	27,357 LF		
0242	7481000000-N	SP	SITE SURVEY	4 EA		
0243	7481200000-N	SP	LUMINAIRE ARM FOR VIDEO SYSTEM	11 EA		
0244	7481240000-N	SP	CAMERA WITHOUT INTERNAL LOOP EMULATOR PROCESSING UNIT	10 EA		
0245	7481260000-N	SP	EXTERNAL LOOP EMULATOR PROCESSING UNIT	4 EA		
0246	7516000000-E	1730	COMMUNICATIONS CABLE (** FIBER) (24)	5,400 LF		
0247	7516000000-E	1730	COMMUNICATIONS CABLE (** FIBER) (96)	6,650 LF		
0248	7528000000-E	1730	DROP CABLE	2,535 LF		
0249	7540000000-N	1731	SPLICE ENCLOSURE	10 EA		
0250	7541000000-N	1731	MODIFY SPLICE ENCLOSURE	3 EA		
0251	7552000000-N	1731	INTERCONNECT CENTER	5 EA		

County: FORSYTH

Line #	Item Number	Sec #	Description	Quantity	Unit Cost	Amount
0252	7566000000-N	1733	DELINEATOR MARKER	13 EA		
0253	7575160000-E	1734	REMOVE EXISTING COMMUNICATIONS CABLE	4,750 LF		
0254	7575180000-N	1735	CABLE TRANSFER	2 EA		
0255	7576000000-N	SP	METAL STRAIN SIGNAL POLE	12 EA		
0256	7613000000-N	SP	SOIL TEST	12 EA		
0257	7614100000-E	SP	DRILLED PIER FOUNDATION	72 CY		
0258	7636000000-N	1745	SIGN FOR SIGNALS	25 EA		
0259	7642100000-N	1743	TYPE I POST WITH FOUNDATION	8 EA		
0260	7642200000-N	1743	TYPE II PEDESTAL WITH FOUNDATION	11 EA		
0261	7684000000-N	1750	SIGNAL CABINET FOUNDATION	3 EA		
0262	7696000000-N	1751	CONTROLLERS WITH CABINET (*****) (2070E, BASE MOUNTED)	3 EA		
0263	7696000000-N	1751	CONTROLLERS WITH CABINET (*****) (2070E, POLE MOUNTED)	1 EA		
0264	7744000000-N	1751	DETECTOR CARD (TYPE 170)	36 EA		
0265	7901000000-N	1753	CABINET BASE EXTENDER	3 EA		
0266	7980000000-N	SP	GENERIC SIGNAL ITEM 5/8" X 10' GROUNDING ELECTRODE	4 EA		
0267	7980000000-N	SP	GENERIC SIGNAL ITEM CCTV WOOD POLE	1 EA		
0268	7980000000-N	SP	GENERIC SIGNAL ITEM DIGITAL CCTV CAMERA ASSEMBLY	1 EA		

County: FORSYTH

Line #	Item Number	Sec #	Description	Quantity	Unit Cost	Amount
0269	7980000000-N	SP	GENERIC SIGNAL ITEM ETHERNET EDGE SWITCH	4 EA		
0270	7980000000-N	SP	GENERIC SIGNAL ITEM FIELD EQUIPMENT CABINET	1 EA		
0271	7980000000-N	SP	GENERIC SIGNAL ITEM METER BASE/DISCONNECT COMBINATION PANEL	1 EA		
0272	7990000000-E	SP	GENERIC SIGNAL ITEM #4 SOLID BARE GROUNDING CONDUCTOR	40 LF		
0273	7990000000-E	SP	GENERIC SIGNAL ITEM 3-WIRE COPPER FEEDER CONDUCTORS	40 LF		
0274	7990000000-E	SP	GENERIC SIGNAL ITEM 3-WIRE COPPER SERVICE ENTRANCE CONDUCTORS	20 LF		
0275	7990000000-E	SP	GENERIC SIGNAL ITEM BACK PULL FIBER OPTIC CABLE	830 LF		
WALL ITEMS						
0276	8801000000-E	SP	MSE RETAINING WALL NO **** (1)	2,815 SF		
0277	8801000000-E	SP	MSE RETAINING WALL NO **** (2)	2,280 SF		
0278	8847000000-E	SP	GENERIC RETAINING WALL ITEM ARCHITECTURAL SURFACE TREATMENT	5,095 SF		
STRUCTURE ITEMS						
0279	8035000000-N	402	REMOVAL OF EXISTING STRUCTURE AT STATION ***** (33+99.11 -L-)	Lump Sum	L.S.	
0280	8065000000-N	SP	ASBESTOS ASSESSMENT	Lump Sum	L.S.	
0281	8091000000-N	410	FOUNDATION EXCAVATION FOR BENT ** AT STATION ***** (1, 33+99.11 -L-)	Lump Sum	L.S.	

County: FORSYTH

Line #	Item Number	Sec #	Description	Quantity	Unit Cost	Amount
0282	8091000000-N	410	FOUNDATION EXCAVATION FOR BENT ** AT STATION ***** (2, 33+99.11 -L-)	Lump Sum	L.S.	
0283	8121000000-N	412	UNCLASSIFIED STRUCTURE EXCAVATION AT STATION ***** (33+99.11 -L-)	Lump Sum	L.S.	
0284	8147000000-E	420	REINFORCED CONCRETE DECK SLAB	17,988 SF		
0285	8161000000-E	420	GROOVING BRIDGE FLOORS	17,900 SF		
0286	8182000000-E	420	CLASS A CONCRETE (BRIDGE)	367.6 CY		
0287	8210000000-N	422	BRIDGE APPROACH SLABS, STATION ***** (33+99.11 -L-)	Lump Sum	L.S.	
0288	8217000000-E	425	REINFORCING STEEL (BRIDGE)	55,961 LB		
0289	8238000000-E	425	SPIRAL COLUMN REINFORCING STEEL (BRIDGE)	3,970 LB		
0290	8262000000-E	430	45" PRESTRESSED CONCRETE GIRDERS	2,255.46 LF		
0291	8328200000-E	450	PILE DRIVING EQUIPMENT SETUP FOR *** STEEL PILES (HP 12 X 53)	74 EA		
0292	8364000000-E	450	HP 12 X 53 STEEL PILES	5,900 LF		
0293	8482000000-E	460	THREE BAR METAL RAIL	397.77 LF		
0294	8531000000-E	462	4" SLOPE PROTECTION	61 SY		
0295	8657000000-N	430	ELASTOMERIC BEARINGS	Lump Sum	L.S.	
0296	8860000000-N	SP	GENERIC STRUCTURE ITEM STRIP SEAL EXPANSION JOINTS	Lump Sum	L.S.	

Vendor 1 of 4: CATON CONSTRUCTION GROUP INC (16466)
Call Order 004 (Proposal: C204837)

Bid Information

Proposal County: FORSYTH

Vendor Address: P.O. Box 4488
CHARLOTTESVILLE , VA , 22905

Signature Check: Diane Elliott Caton

Time Bid Received: June 20, 2023 01:37 PM

Amendment Count: 0

Bid Checksum: BB79C6C5C8

Bid Total: \$23,925,288.63

Items Total: \$23,925,288.63

Time Total: \$0.00

Bidding Errors:

None.

DBE GOAL SET: 4.00%
DBE GOAL OBT: 4.04%

Vendor 1 of 4: CATON CONSTRUCTION GROUP INC (16466)
Call Order 004 (Proposal: C204837)

Bid Bond Information

Projects:	Bond Maximum:
Counties:	State of Incorporation:
Bond ID: SNC06152828	Agency Execution Date: 06/15/2023 02
Paid by Check: No	Surety Name: Surety2000
Bond Percent: 5%	Bond Agency Name: Markel Insurance Company

DBE Load Information

Letting ID: L230620
Letting Date: 06/20/2023
Call Order: 004
Contract ID: C204837
Project: STATE FUNDEDSTATE FUNDEDSTATE FUNDEDSTATE FUNDED
Bid Total: \$23,925,288.63
DBE Goal: 4.00% (\$957,011.55)

DBE GOAL SET: 4.00%
DBE GOAL OBT: 4.04%

Vendor ID: 16466
Vendor Name: Caton Construction Group, Inc.
DBE Entered: 4.04% (\$967,124.84)

Vendor ID	DBE Name	Is Supplier?	City/State	Goods/Service	Amount
16042	NPS SOLUTIONS LLC	False	P.O. Box 58344 RALEIGH, NC 27658	SubContractor Committed	347,288.27
12802	NICKELSTON INDUSTRIES INC	False	P.O. Box 133 LAWSONVILLE, NC 27022	SubContractor Committed	131,385.41
4388	FOOTHILLS CONSTRUCTION SERVICES INC	False	6081 PEA RIDGE PASS HAMPTONVILLE, NC 27020	SubContractor Committed	420,512.58
12578	LOPEZ REBAR LLC	False	2641 EVA DRIVE NW CONCORD, NC 28027	SubContractor Committed	67,938.58

Letting: L230620
06/20/2023 02:00:00 PM

North Carolina Department of Transportation
16466 - Caton Construction Group, Inc.

Contract ID: C204837
Call: 004

BondID: SNC06152828
Surety Registry Agency: Surety2000
Verified?: 1
Surety Agency: Markel Insurance Company
Bond Execution Date: 06/15/2023 02:25:10 PM

Line Number	Item Number	Quantity	Unit	Unit Price	Extension Price
Section 0001 ROADWAY ITEMS					
0001	0000100000-N MOBILIZATION	1.000	LS	\$1,196,264.4300	\$1,196,264.43
0002	0000400000-N CONSTRUCTION SURVEYING	1.000	LS	\$149,657.5000	\$149,657.50
0003	0008000000-E SUPPLEMENTARY CLEARING & GRUBBING	1.000	ACR	\$14,965.7500	\$14,965.75
0004	0015000000-N SEALING ABANDONED WELLS	2.000	EA	\$1,455.2200	\$2,910.44
0005	0029000000-N TYPE III REINFORCED APPROACH FILL, STATION ***** (33+99.11 -L-)	1.000	LS	\$152,434.0000	\$152,434.00
0006	0043000000-N GRADING	1.000	LS	\$2,882,823.1700	\$2,882,823.17
0007	0057000000-E UNDERCUT EXCAVATION	450.000	CY	\$20.3300	\$9,148.50
0008	0134000000-E DRAINAGE DITCH EXCAVATION	290.000	CY	\$8.8700	\$2,572.30
0009	0194000000-E SELECT GRANULAR MATERIAL, CLASS III	400.000	CY	\$94.2300	\$37,692.00
0010	0196000000-E GEOTEXTILE FOR SOIL STABILIZATION	500.000	SY	\$1.4400	\$720.00
0011	0199000000-E TEMPORARY SHORING	6232.000	SF	\$52.4700	\$326,993.04
0012	0318000000-E FOUNDATION CONDITIONING MATERIAL, MINOR STRUCTURES	735.000	TON	\$71.3100	\$52,412.85
0013	0320000000-E FOUNDATION CONDITIONING GEOTEXTILE	2300.000	SY	\$3.1800	\$7,314.00
0014	0448200000-E 15" RC PIPE CULVERTS, CLASS IV	1024.000	LF	\$136.2100	\$139,479.04
0015	0448300000-E 18" RC PIPE CULVERTS, CLASS IV	3746.000	LF	\$174.3900	\$653,264.94
0016	0448400000-E 24" RC PIPE CULVERTS, CLASS IV	988.000	LF	\$205.3900	\$202,925.32
0017	0448500000-E 30" RC PIPE CULVERTS, CLASS IV	80.000	LF	\$316.2900	\$25,303.20
0018	0448600000-E 36" RC PIPE CULVERTS, CLASS IV	16.000	LF	\$247.7100	\$3,963.36
0019	0448700000-E 42" RC PIPE CULVERTS, CLASS IV	288.000	LF	\$328.0500	\$94,478.40
0020	0582000000-E 15" CS PIPE CULVERTS, 0.064" THICK	164.000	LF	\$90.2300	\$14,797.72
0021	0588000000-E 18" CS PIPE CULVERTS, 0.064" THICK	220.000	LF	\$102.6400	\$22,580.80
0022	0594000000-E 24" CS PIPE CULVERTS, 0.064" THICK	44.000	LF	\$116.2100	\$5,113.24
0023	0636000000-E **" CS PIPE ELBOWS, ***** THICK (15", 0.064")	10.000	EA	\$478.1500	\$4,781.50

0024	0636000000-E	6.000 EA	\$521.7300	\$3,130.38
	*** CS PIPE ELBOWS, ***** THICK (18", 0.064")			
0025	0636000000-E	2.000 EA	\$672.4700	\$1,344.94
	*** CS PIPE ELBOWS, ***** THICK (24", 0.064")			
0026	0995000000-E	4135.000 LF	\$49.1700	\$203,317.95
	PIPE REMOVAL			
0027	1004500000-E	7200.000 SY	\$1.4400	\$10,368.00
	GENERIC GRADING ITEM GEOTEXTILE FOR SUBGRADE STABILIZATION			
0028	1099500000-E	2800.000 CY	\$36.2500	\$101,500.00
	SHALLOW UNDERCUT			
0029	1099700000-E	6600.000 TON	\$60.5100	\$399,366.00
	CLASS IV SUBGRADE STABILIZATION			
0030	1220000000-E	200.000 TON	\$63.6900	\$12,738.00
	INCIDENTAL STONE BASE			
0031	1245000000-E	3.600 SMI	\$58,353.5000	\$210,072.60
	SHOULDER RECONSTRUCTION			
0032	1260000000-E	2000.000 TON	\$71.3900	\$142,780.00
	AGGREGATE SHOULDER BORROW			
0033	1297000000-E	2340.000 SY	\$7.5000	\$17,550.00
	MILLING ASPHALT PAVEMENT, ***" DEPTH (4")			
0034	1297000000-E	11390.000 SY	\$3.4300	\$39,067.70
	MILLING ASPHALT PAVEMENT, ***" DEPTH (6")			
0035	1330000000-E	26850.000 SY	\$3.6800	\$98,808.00
	INCIDENTAL MILLING			
0036	1491000000-E	14230.000 TON	\$90.2400	\$1,284,115.20
	ASPHALT CONC BASE COURSE, TYPE B25.0C			
0037	1503000000-E	10320.000 TON	\$90.2400	\$931,276.80
	ASPHALT CONC INTERMEDIATE COURSE, TYPE I19.0C			
0038	1519000000-E	5990.000 TON	\$90.2400	\$540,537.60
	ASPHALT CONC SURFACE COURSE, TYPE S9.5B			
0039	1523000000-E	960.000 TON	\$110.3100	\$105,897.60
	ASPHALT CONC SURFACE COURSE, TYPE S9.5C			
0040	1575000000-E	1585.000 TON	\$852.3100	\$1,350,911.35
	ASPHALT BINDER FOR PLANT MIX			
0041	1577000000-E	55.000 TON	\$1,002.7300	\$55,150.15
	POLYMER MODIFIED ASPHALT BINDER FOR PLANT MIX			
0042	1693000000-E	800.000 TON	\$313.5900	\$250,872.00
	ASPHALT PLANT MIX, PAVEMENT REPAIR			
0043	1839140000-E	1010.000 TON	\$175.4700	\$177,224.70
	ULTRA-THIN BONDED WEARING COURSE			
0044	1840000000-E	14760.000 LF	\$1.3200	\$19,483.20
	MILLED RUMBLE STRIPS (ASPHALT CONCRETE)			
0045	1891000000-E	28650.000 SY	\$1.9100	\$54,721.50
	GENERIC PAVING ITEM FINE MILLING			
0046	2000000000-N	70.000 EA	\$149.6600	\$10,476.20
	RIGHT-OF-WAY MARKERS			
0047	2022000000-E	44.800 CY	\$82.6600	\$3,703.17
	SUBDRAIN EXCAVATION			
0048	2026000000-E	200.000 SY	\$21.9900	\$4,398.00

GEOTEXTILE FOR SUBSURFACE DRAINS

0049	2036000000-E	33.600 CY	\$154.4900	\$5,190.86
	SUBDRAIN COARSE AGGREGATE			
0050	2044000000-E	200.000 LF	\$37.9000	\$7,580.00
	6" PERFORATED SUBDRAIN PIPE			
0051	2070000000-N	1.000 EA	\$1,605.4900	\$1,605.49
	SUBDRAIN PIPE OUTLET			
0052	2077000000-E	6.000 LF	\$104.1200	\$624.72
	6" OUTLET PIPE			
0053	2190000000-N	7.000 EA	\$1,212.1600	\$8,485.12
	TEMPORARY STEEL PLATE COVERS FOR MASONRY DRAINAGE STRUCTURE			
0054	2209000000-E	3.400 CY	\$2,778.8600	\$9,448.12
	ENDWALLS			
0055	2275000000-E	2.000 CY	\$538.3700	\$1,076.74
	FLOWABLE FILL			
0056	2286000000-N	112.000 EA	\$4,200.5500	\$470,461.60
	MASONRY DRAINAGE STRUCTURES			
0057	2308000000-E	47.100 LF	\$850.1800	\$40,043.48
	MASONRY DRAINAGE STRUCTURES			
0058	2364000000-N	26.000 EA	\$1,344.2600	\$34,950.76
	FRAME WITH TWO GRATES, STD 840.16			
0059	2374000000-N	7.000 EA	\$1,710.3800	\$11,972.66
	FRAME WITH GRATE & HOOD, STD 840.03, TYPE ** (E)			
0060	2374000000-N	41.000 EA	\$1,710.3800	\$70,125.58
	FRAME WITH GRATE & HOOD, STD 840.03, TYPE ** (F)			
0061	2374000000-N	28.000 EA	\$1,710.3800	\$47,890.64
	FRAME WITH GRATE & HOOD, STD 840.03, TYPE ** (G)			
0062	2396000000-N	12.000 EA	\$1,265.9000	\$15,190.80
	FRAME WITH COVER, STD 840.54			
0063	2535000000-E	490.000 LF	\$33.1800	\$16,258.20
	**" X **" CONCRETE CURB (8" X 12")			
0064	2542000000-E	1120.000 LF	\$33.1800	\$37,161.60
	1'-6" CONCRETE CURB & GUTTER			
0065	2549000000-E	10940.000 LF	\$34.6800	\$379,399.20
	2'-6" CONCRETE CURB & GUTTER			
0066	2591000000-E	4160.000 SY	\$40.4000	\$168,064.00
	4" CONCRETE SIDEWALK			
0067	2605000000-N	45.000 EA	\$2,793.6000	\$125,712.00
	CONCRETE CURB RAMPS			
0068	2612000000-E	30.000 SY	\$49.8900	\$1,496.70
	6" CONCRETE DRIVEWAY			
0069	2655000000-E	4620.000 SY	\$79.8000	\$368,676.00
	5" MONOLITHIC CONCRETE ISLANDS (KEYED IN)			
0070	2724000000-E	425.000 LF	\$97.3000	\$41,352.50
	PRECAST REINFORCED CONCRETE BARRIER, SINGLE FACED			
0071	2738000000-E	630.000 SY	\$139.6700	\$87,992.10
	GENERIC PAVING ITEM 9" CONCRETE TRUCK APRON			
0072	2753000000-E	240.000 LF	\$34.6800	\$8,323.20
	GENERIC PAVING ITEM 2'-6" CONCRETE CURB AND GUTTER (MODIFIED)			

0073	2753000000-E	360.000 LF	\$36.1900	\$13,028.40
	GENERIC PAVING ITEM CONCRETE VALLEY GUTTER (MODIFIED)			
0074	2830000000-N	17.000 EA	\$1,720.0500	\$29,240.85
	ADJUSTMENT OF MANHOLES			
0075	2845000000-N	10.000 EA	\$1,084.1200	\$10,841.20
	ADJUSTMENT OF METER BOXES OR VALVE BOXES			
0076	2950000000-N	1.000 EA	\$3,440.1000	\$3,440.10
	CONVERT EXISTING JUNCTION BOX TO DROP INLET			
0077	3030000000-E	1737.500 LF	\$27.9300	\$48,528.38
	STEEL BEAM GUARDRAIL			
0078	3045000000-E	275.000 LF	\$30.9300	\$8,505.75
	STEEL BEAM GUARDRAIL, SHOP CURVED			
0079	3150000000-N	5.000 EA	\$54.8700	\$274.35
	ADDITIONAL GUARDRAIL POSTS			
0080	3195000000-N	1.000 EA	\$1,247.1700	\$1,247.17
	GUARDRAIL END UNITS, TYPE AT-1			
0081	3210000000-N	6.000 EA	\$1,247.1600	\$7,482.96
	GUARDRAIL END UNITS, TYPE CAT-1			
0082	3215000000-N	3.000 EA	\$2,793.6200	\$8,380.86
	GUARDRAIL ANCHOR UNITS, TYPE III			
0083	3287000000-N	5.000 EA	\$3,791.3500	\$18,956.75
	GUARDRAIL END UNITS, TYPE TL-3			
0084	3288000000-N	1.000 EA	\$3,591.8000	\$3,591.80
	GUARDRAIL END UNITS, TYPE TL-2			
0085	3317000000-N	8.000 EA	\$2,793.6000	\$22,348.80
	GUARDRAIL ANCHOR UNITS, TYPE B-77			
0086	3360000000-E	1404.000 LF	\$1.2600	\$1,769.04
	REMOVE EXISTING GUARDRAIL			
0087	3533000000-E	300.000 LF	\$23.9400	\$7,182.00
	CHAIN LINK FENCE, *** FABRIC (72")			
0088	3539000000-E	25.000 EA	\$94.7700	\$2,369.25
	METAL LINE POSTS FOR *** CHAIN LINK FENCE (72")			
0089	3545000000-E	5.000 EA	\$149.6600	\$748.30
	METAL TERMINAL POSTS FOR *** CHAIN LINK FENCE (72")			
0090	3649000000-E	325.000 TON	\$83.1000	\$27,007.50
	RIP RAP, CLASS B			
0091	3656000000-E	2330.000 SY	\$2.3900	\$5,568.70
	GEOTEXTILE FOR DRAINAGE			
0092	4048000000-E	4.000 CY	\$1,197.2700	\$4,789.08
	REINFORCED CONCRETE SIGN FOUNDATIONS			
0093	4054000000-E	2.000 CY	\$798.1600	\$1,596.32
	PLAIN CONCRETE SIGN FOUNDATIONS			
0094	4060000000-E	3114.000 LB	\$9.9700	\$31,046.58
	SUPPORTS, BREAKAWAY STEEL BEAM			
0095	4066000000-E	1850.000 LB	\$7.9900	\$14,781.50
	SUPPORTS, SIMPLE STEEL BEAM			
0096	4072000000-E	1450.000 LF	\$7.9900	\$11,585.50
	SUPPORTS, 3-LB STEEL U-CHANNEL			
0097	4096000000-N	2.000 EA	\$299.3100	\$598.62

SIGN ERECTION, TYPE D					
0098	4102000000-N	76.000	EA	\$99.7800	\$7,583.28
SIGN ERECTION, TYPE E					
0099	4108000000-N	4.000	EA	\$124.7200	\$498.88
SIGN ERECTION, TYPE F					
0100	4110000000-N	10.000	EA	\$99.8000	\$998.00
SIGN ERECTION, TYPE *** (GROUND MOUNTED) (A)					
0101	4110000000-N	2.000	EA	\$99.7900	\$199.58
SIGN ERECTION, TYPE *** (GROUND MOUNTED) (B)					
0102	4116100000-N	5.000	EA	\$249.4500	\$1,247.25
SIGN ERECTION, RELOCATE TYPE **** (GROUND MOUNTED) (A)					
0103	4116100000-N	2.000	EA	\$249.4400	\$498.88
SIGN ERECTION, RELOCATE TYPE **** (GROUND MOUNTED) (B)					
0104	4116100000-N	7.000	EA	\$249.4300	\$1,746.01
SIGN ERECTION, RELOCATE TYPE **** (GROUND MOUNTED) (E)					
0105	4138000000-N	7.000	EA	\$99.7900	\$698.53
DISPOSAL OF SUPPORT, STEEL BEAM					
0106	4152000000-N	1.000	EA	\$149.6900	\$149.69
DISPOSAL OF SIGN SYSTEM, STEEL BEAM					
0107	4155000000-N	50.000	EA	\$99.7800	\$4,989.00
DISPOSAL OF SIGN SYSTEM, U-CHANNEL					
0108	4192000000-N	7.000	EA	\$99.7800	\$698.46
DISPOSAL OF SUPPORT, U-CHANNEL					
0109	4400000000-E	561.000	SF	\$6.9900	\$3,921.39
WORK ZONE SIGNS (STATIONARY)					
0110	4402000000-E	192.000	SF	\$9.1800	\$1,762.56
HIGH VISIBILITY STATIONARY SIGNS					
0111	4405000000-E	680.000	SF	\$8.8400	\$6,011.20
WORK ZONE SIGNS (PORTABLE)					
0112	4407000000-E	554.000	SF	\$9.7300	\$5,390.42
HIGH VISIBILITY PORTABLE SIGNS					
0113	4410000000-E	54.000	SF	\$9.4800	\$511.92
WORK ZONE SIGNS (BARRICADE MOUNTED)					
0114	4415000000-N	5.000	EA	\$2,394.5300	\$11,972.65
FLASHING ARROW BOARD					
0115	4420000000-N	4.000	EA	\$10,376.2500	\$41,505.00
PORTABLE CHANGEABLE MESSAGE SIGN					
0116	4430000000-N	300.000	EA	\$45.8900	\$13,767.00
DRUMS					
0117	4432000000-N	182.000	EA	\$59.3500	\$10,801.70
HIGH VISIBILITY DRUMS					
0118	4434000000-N	12.000	EA	\$139.6700	\$1,676.04
SEQUENTIAL FLASHING WARNING LIGHTS					
0119	4435000000-N	100.000	EA	\$21.9500	\$2,195.00
CONES					
0120	4445000000-E	56.000	LF	\$25.9400	\$1,452.64
BARRICADES (TYPE III)					
0121	4447000000-E	314.000	LF	\$74.8300	\$23,496.62
PEDESTRIAN CHANNELIZING DEVICES					

0122	4455000000-N FLAGGER	390.000 DAY	\$368.2200	\$143,605.80
0123	4465000000-N TEMPORARY CRASH CUSHIONS	9.000 EA	\$11,366.2500	\$102,296.25
0124	4470000000-N REMOVE & RESET TEMPORARY CRASH CUSHION	1.000 EA	\$2,980.5500	\$2,980.55
0125	4480000000-N TMA	2.000 EA	\$52,679.5000	\$105,359.00
0126	4485000000-E PORTABLE CONCRETE BARRIER	1720.000 LF	\$50.6200	\$87,066.40
0127	4490000000-E PORTABLE CONCRETE BARRIER (ANCHORED)	200.000 LF	\$72.6900	\$14,538.00
0128	4505000000-E REMOVE & RESET PORTABLE CONCRETE BARRIER (ANCHORED)	550.000 LF	\$25.2400	\$13,882.00
0129	4510000000-N LAW ENFORCEMENT	240.000 HR	\$99.7800	\$23,947.20
0130	4600000000-N GENERIC TRAFFIC CONTROL ITEM AUDIBLE WARNING DEVICES	3.000 EA	\$384.1200	\$1,152.36
0131	4600000000-N GENERIC TRAFFIC CONTROL ITEM PEDESTRIAN TRANSPORT SERVICE (PER TRIP)	300.000 EA	\$149.6600	\$44,898.00
0132	4650000000-N TEMPORARY RAISED PAVEMENT MARKERS	840.000 EA	\$8.2300	\$6,913.20
0133	4685000000-E THERMOPLASTIC PAVEMENT MARKING LINES (4", 90 MILS)	18388.000 LF	\$0.8800	\$16,181.44
0134	4688000000-E THERMOPLASTIC PAVEMENT MARKING LINES (6", 90 MILS)	25350.000 LF	\$1.3000	\$32,955.00
0135	4695000000-E THERMOPLASTIC PAVEMENT MARKING LINES (8", 90 MILS)	4240.000 LF	\$2.3200	\$9,836.80
0136	4700000000-E THERMOPLASTIC PAVEMENT MARKING LINES (12", 90 MILS)	1860.000 LF	\$2.8400	\$5,282.40
0137	4709000000-E THERMOPLASTIC PAVEMENT MARKING LINES (24", 90 MILS)	1950.000 LF	\$10.0300	\$19,558.50
0138	4720000000-E THERMOPLASTIC PAVEMENT MARKING CHARACTER (90 MILS)	12.000 EA	\$128.5700	\$1,542.84
0139	4725000000-E THERMOPLASTIC PAVEMENT MARKING SYMBOL (90 MILS)	109.000 EA	\$159.4400	\$17,378.96
0140	4770000000-E COLD APPLIED PLASTIC PAVEMENT MARKING LINES, TYPE ** (4") (II)	1362.000 LF	\$2.8400	\$3,868.08
0141	4770000000-E COLD APPLIED PLASTIC PAVEMENT MARKING LINES, TYPE ** (4") (IV)	2599.000 LF	\$3.8800	\$10,084.12
0142	4805000000-N COLD APPLIED PLASTIC PAVEMENT MARKING SYMBOL, TYPE ** (II)	4.000 EA	\$1,249.7200	\$4,998.88
0143	4805000000-N COLD APPLIED PLASTIC PAVEMENT MARKING SYMBOL, TYPE ** (IV)	3.000 EA	\$668.5900	\$2,005.77
0144	4810000000-E PAINT PAVEMENT MARKING LINES (4")	155202.000 LF	\$0.2100	\$32,592.42
0145	4815000000-E PAINT PAVEMENT MARKING LINES (6")	35352.000 LF	\$0.4600	\$16,261.92
0146	4820000000-E	19034.000 LF	\$0.6700	\$12,752.78

PAINT PAVEMENT MARKING LINES (8")				
0147	4825000000-E	2120.000	LF	\$1.5300 \$3,243.60
PAINT PAVEMENT MARKING LINES (12")				
0148	4835000000-E	2892.000	LF	\$2.0000 \$5,784.00
PAINT PAVEMENT MARKING LINES (24")				
0149	4840000000-N	28.000	EA	\$36.0000 \$1,008.00
PAINT PAVEMENT MARKING CHARACTER				
0150	4845000000-N	300.000	EA	\$46.2900 \$13,887.00
PAINT PAVEMENT MARKING SYMBOL				
0151	4850000000-E	48050.000	LF	\$0.6700 \$32,193.50
REMOVAL OF PAVEMENT MARKING LINES (4")				
0152	4855000000-E	19109.000	LF	\$1.0200 \$19,491.18
REMOVAL OF PAVEMENT MARKING LINES (6")				
0153	4860000000-E	2105.000	LF	\$1.5300 \$3,220.65
REMOVAL OF PAVEMENT MARKING LINES (8")				
0154	4865000000-E	500.000	LF	\$2.0500 \$1,025.00
REMOVAL OF PAVEMENT MARKING LINES (12")				
0155	4870000000-E	915.000	LF	\$3.5800 \$3,275.70
REMOVAL OF PAVEMENT MARKING LINES (24")				
0156	4875000000-N	173.000	EA	\$66.8600 \$11,566.78
REMOVAL OF PAVEMENT MARKING SYMBOLS & CHARACTERS				
0157	4900000000-N	25.000	EA	\$8.2300 \$205.75
PERMANENT RAISED PAVEMENT MARKERS				
0158	4905100000-N	900.000	EA	\$66.8600 \$60,174.00
NON-CAST IRON SNOWPLOWABLE PAVEMENT MARKER				
0159	5255000000-N	1.000	LS	\$55,361.0000 \$55,361.00
PORTABLE LIGHTING				
0160	5325600000-E	184.000	LF	\$329.9100 \$60,703.44
6" WATER LINE				
0161	5326200000-E	270.000	LF	\$294.3800 \$79,482.60
12" WATER LINE				
0162	5326600000-E	353.000	LF	\$422.1900 \$149,033.07
16" WATER LINE				
0163	5329000000-E	10695.000	LB	\$10.4700 \$111,976.65
DUCTILE IRON WATER PIPE FITTINGS				
0164	5540000000-E	4.000	EA	\$3,188.1500 \$12,752.60
6" VALVE				
0165	5558000000-E	2.000	EA	\$7,696.2500 \$15,392.50
12" VALVE				
0166	5558600000-E	1.000	EA	\$19,300.2500 \$19,300.25
16" VALVE				
0167	5648000000-N	14.000	EA	\$3,104.2500 \$43,459.50
RELOCATE WATER METER				
0168	5649000000-N	3.000	EA	\$2,502.7500 \$7,508.25
RECONNECT WATER METER				
0169	5656100000-E	4.000	EA	\$2,179.5200 \$8,718.08
RELOCATE *** RPZ BACKFLOW PREVENTION ASSEMBLY (1")				
0170	5656210000-E	1.000	EA	\$2,792.2500 \$2,792.25
RELOCATE 2" RPZ BACKFLOW PREVENTION ASSEMBLY				

0171	5666000000-N	3.000	EA	\$9,853.6500	\$29,560.95
	FIRE HYDRANT				
0172	5672000000-N	2.000	EA	\$2,218.4900	\$4,436.98
	RELOCATE FIRE HYDRANT				
0173	5673000000-E	237.000	LF	\$239.9000	\$56,856.30
	FIRE HYDRANT LEG				
0174	5686500000-E	827.000	LF	\$85.2200	\$70,476.94
	WATER SERVICE LINE				
0175	5691300000-E	195.000	LF	\$241.6700	\$47,125.65
	8" SANITARY GRAVITY SEWER				
0176	5768000000-N	11.000	EA	\$6,097.5500	\$67,073.05
	SANITARY SEWER CLEAN-OUT				
0177	5768500000-E	194.000	LF	\$164.5000	\$31,913.00
	SEWER SERVICE LINE				
0178	5775000000-E	3.000	EA	\$7,711.9000	\$23,135.70
	4' DIA UTILITY MANHOLE				
0179	5781000000-E	8.000	LF	\$313.7300	\$2,509.84
	UTILITY MANHOLE WALL 4' DIA				
0180	5800000000-E	714.000	LF	\$47.8200	\$34,143.48
	ABANDON 6" UTILITY PIPE				
0181	5801000000-E	161.000	LF	\$79.6800	\$12,828.48
	ABANDON 8" UTILITY PIPE				
0182	5804000000-E	260.000	LF	\$78.4000	\$20,384.00
	ABANDON 12" UTILITY PIPE				
0183	5816000000-N	3.000	EA	\$1,141.0600	\$3,423.18
	ABANDON UTILITY MANHOLE				
0184	6000000000-E	14035.000	LF	\$4.3500	\$61,052.25
	TEMPORARY SILT FENCE				
0185	6006000000-E	700.000	TON	\$70.9200	\$49,644.00
	STONE FOR EROSION CONTROL, CLASS A				
0186	6009000000-E	1360.000	TON	\$75.6500	\$102,884.00
	STONE FOR EROSION CONTROL, CLASS B				
0187	6012000000-E	2255.000	TON	\$57.8100	\$130,361.55
	SEDIMENT CONTROL STONE				
0188	6015000000-E	43.000	ACR	\$1,601.3300	\$68,857.19
	TEMPORARY MULCHING				
0189	6018000000-E	2100.000	LB	\$1.9900	\$4,179.00
	SEED FOR TEMPORARY SEEDING				
0190	6021000000-E	12.500	TON	\$1,089.5200	\$13,619.00
	FERTILIZER FOR TEMPORARY SEEDING				
0191	6024000000-E	635.000	LF	\$16.5000	\$10,477.50
	TEMPORARY SLOPE DRAINS				
0192	6029000000-E	1600.000	LF	\$3.7400	\$5,984.00
	SAFETY FENCE				
0193	6030000000-E	4270.000	CY	\$1.9000	\$8,113.00
	SILT EXCAVATION				
0194	6036000000-E	20800.000	SY	\$1.9800	\$41,184.00
	MATTING FOR EROSION CONTROL				
0195	6037000000-E	40.000	SY	\$4.5000	\$180.00

COIR FIBER MAT

0196	6038000000-E	75.000	SY	\$7.3700	\$552.75
	PERMANENT SOIL REINFORCEMENT MAT				
0197	6042000000-E	8625.000	LF	\$3.7500	\$32,343.75
	1/4" HARDWARE CLOTH				
0198	6071012000-E	400.000	LF	\$11.4800	\$4,592.00
	COIR FIBER WATTLE				
0199	6071020000-E	115.000	LB	\$23.7100	\$2,726.65
	POLYACRYLAMIDE (PAM)				
0200	6071030000-E	645.000	LF	\$8.5400	\$5,508.30
	COIR FIBER BAFFLE				
0201	6071050000-E	2.000	EA	\$2,904.0600	\$5,808.12
	*** SKIMMER (1-1/2")				
0202	6071050000-E	1.000	EA	\$3,067.1500	\$3,067.15
	*** SKIMMER (2")				
0203	6084000000-E	33.000	ACR	\$4,090.6500	\$134,991.45
	SEEDING & MULCHING				
0204	6087000000-E	30.000	ACR	\$149.6600	\$4,489.80
	MOWING				
0205	6090000000-E	450.000	LB	\$4.1500	\$1,867.50
	SEED FOR REPAIR SEEDING				
0206	6093000000-E	1.250	TON	\$1,089.5200	\$1,361.90
	FERTILIZER FOR REPAIR SEEDING				
0207	6096000000-E	775.000	LB	\$4.9800	\$3,859.50
	SEED FOR SUPPLEMENTAL SEEDING				
0208	6108000000-E	23.250	TON	\$1,089.5200	\$25,331.34
	FERTILIZER TOPDRESSING				
0209	6114500000-N	10.000	MHR	\$34.9200	\$349.20
	SPECIALIZED HAND MOWING				
0210	6114800000-N	17.000	MHR	\$149.6600	\$2,544.22
	MANUAL LITTER REMOVAL				
0211	6114900000-E	2.000	TON	\$149.6500	\$299.30
	LITTER DISPOSAL				
0212	6117000000-N	100.000	EA	\$74.8300	\$7,483.00
	RESPONSE FOR EROSION CONTROL				
0213	6117500000-N	10.000	EA	\$498.8600	\$4,988.60
	CONCRETE WASHOUT STRUCTURE				
0214	6132000000-N	108.000	EA	\$174.6000	\$18,856.80
	GENERIC EROSION CONTROL ITEM FABRIC INSERT INLET PROTECTION DEVICE				
0215	6132000000-N	324.000	EA	\$174.6000	\$56,570.40
	GENERIC EROSION CONTROL ITEM FABRIC INSERT INLET PROTECTION DEVICE CLEANOUT				
0216	7048500000-E	20.000	EA	\$1,048.1200	\$20,962.40
	PEDESTRIAN SIGNAL HEAD (16", 1 SECTION W/COUNTDOWN)				
0217	7060000000-E	9225.000	LF	\$3.5100	\$32,379.75
	SIGNAL CABLE				
0218	7120000000-E	60.000	EA	\$967.4800	\$58,048.80
	VEHICLE SIGNAL HEAD (12", 3 SECTION)				
0219	7132000000-E	9.000	EA	\$1,224.4600	\$11,020.14
	VEHICLE SIGNAL HEAD (12", 4 SECTION)				

0220	7144000000-E	9.000 EA	\$1,662.8600	\$14,965.74
	VEHICLE SIGNAL HEAD (12", 5 SECTION)			
0221	7252000000-E	3375.000 LF	\$3.5100	\$11,846.25
	MESSENGER CABLE (1/4")			
0222	7264000000-E	3585.000 LF	\$5.5400	\$19,860.90
	MESSENGER CABLE (3/8")			
0223	7279000000-E	2270.000 LF	\$1.0100	\$2,292.70
	TRACER WIRE			
0224	7288000000-E	100.000 LF	\$58.4500	\$5,845.00
	PAVED TRENCHING (***** (1, 2"))			
0225	7300000000-E	1865.000 LF	\$9.5600	\$17,829.40
	UNPAVED TRENCHING (***** (1, 2"))			
0226	7300000000-E	20.000 LF	\$30.2400	\$604.80
	UNPAVED TRENCHING (***** (2, 2"))			
0227	7300000000-E	115.000 LF	\$35.2800	\$4,057.20
	UNPAVED TRENCHING (***** (3, 2"))			
0228	7301000000-E	405.000 LF	\$20.1600	\$8,164.80
	DIRECTIONAL DRILL (***** (1, 2"))			
0229	7301000000-E	925.000 LF	\$24.7000	\$22,847.50
	DIRECTIONAL DRILL (***** (2, 2"))			
0230	7301000000-E	1050.000 LF	\$26.2000	\$27,510.00
	DIRECTIONAL DRILL (***** (3, 2"))			
0231	7312000000-N	6.000 EA	\$2,297.7700	\$13,786.62
	JUNCTION BOX (***** (SPECIAL OVERSIZED, HEAVY DUTY, 36" X 24" X 24"))			
0232	7324000000-N	31.000 EA	\$564.3700	\$17,495.47
	JUNCTION BOX (STANDARD SIZE)			
0233	7348000000-N	13.000 EA	\$1,098.5100	\$14,280.63
	JUNCTION BOX (OVER-SIZED, HEAVY DUTY)			
0234	7360000000-N	4.000 EA	\$1,310.1400	\$5,240.56
	WOOD POLE			
0235	7372000000-N	33.000 EA	\$907.0200	\$29,931.66
	GUY ASSEMBLY			
0236	7396000000-E	7.000 EA	\$403.1200	\$2,821.84
	1/2" RISER WITH WEATHERHEAD			
0237	7408000000-E	5.000 EA	\$503.8800	\$2,519.40
	1" RISER WITH WEATHERHEAD			
0238	7420000000-E	8.000 EA	\$1,007.8000	\$8,062.40
	2" RISER WITH WEATHERHEAD			
0239	7432000000-E	12.000 EA	\$1,209.3600	\$14,512.32
	2" RISER WITH HEAT SHRINK TUBING			
0240	7444000000-E	5475.000 LF	\$10.0800	\$55,188.00
	INDUCTIVE LOOP SAWCUT			
0241	7456000000-E	27357.000 LF	\$2.0100	\$54,987.57
	LEAD-IN CABLE (***** (14-2))			
0242	7481000000-N	4.000 EA	\$1,007.8000	\$4,031.20
	SITE SURVEY			
0243	7481200000-N	11.000 EA	\$1,158.9800	\$12,748.78
	LUMINAIRE ARM FOR VIDEO SYSTEM			
0244	7481240000-N	10.000 EA	\$6,248.4000	\$62,484.00

CAMERA WITHOUT INTERNAL LOOP EMULATOR PROCESSING UNIT

0245	7481260000-N	4.000 EA	\$4,635.8500	\$18,543.40
	EXTERNAL LOOP EMULATOR PROCESSING UNIT			
0246	7516000000-E	5400.000 LF	\$3.3000	\$17,820.00
	COMMUNICATIONS CABLE (** FIBER) (24)			
0247	7516000000-E	6650.000 LF	\$4.4300	\$29,459.50
	COMMUNICATIONS CABLE (** FIBER) (96)			
0248	7528000000-E	2535.000 LF	\$3.5100	\$8,897.85
	DROP CABLE			
0249	7540000000-N	10.000 EA	\$5,190.2000	\$51,902.00
	SPLICE ENCLOSURE			
0250	7541000000-N	3.000 EA	\$1,511.7000	\$4,535.10
	MODIFY SPLICE ENCLOSURE			
0251	7552000000-N	5.000 EA	\$1,814.0300	\$9,070.15
	INTERCONNECT CENTER			
0252	7566000000-N	13.000 EA	\$138.0800	\$1,795.04
	DELINEATOR MARKER			
0253	7575160000-E	4750.000 LF	\$1.5100	\$7,172.50
	REMOVE EXISTING COMMUNICATIONS CABLE			
0254	7575180000-N	2.000 EA	\$503.8900	\$1,007.78
	CABLE TRANSFER			
0255	7576000000-N	12.000 EA	\$14,209.7500	\$170,517.00
	METAL STRAIN SIGNAL POLE			
0256	7613000000-N	12.000 EA	\$1,310.1400	\$15,721.68
	SOIL TEST			
0257	7614100000-E	72.000 CY	\$1,536.9000	\$110,656.80
	DRILLED PIER FOUNDATION			
0258	7636000000-N	25.000 EA	\$503.8800	\$12,597.00
	SIGN FOR SIGNALS			
0259	7642100000-N	8.000 EA	\$1,763.6300	\$14,109.04
	TYPE I POST WITH FOUNDATION			
0260	7642200000-N	11.000 EA	\$2,922.5700	\$32,148.27
	TYPE II PEDESTAL WITH FOUNDATION			
0261	7684000000-N	3.000 EA	\$3,023.4000	\$9,070.20
	SIGNAL CABINET FOUNDATION			
0262	7696000000-N	3.000 EA	\$20,155.7500	\$60,467.25
	CONTROLLERS WITH CABINET (***** (2070E, BASE MOUNTED)			
0263	7696000000-N	1.000 EA	\$18,140.2500	\$18,140.25
	CONTROLLERS WITH CABINET (***** (2070E, POLE MOUNTED)			
0264	7744000000-N	36.000 EA	\$251.9500	\$9,070.20
	DETECTOR CARD (TYPE 170)			
0265	7901000000-N	3.000 EA	\$725.6200	\$2,176.86
	CABINET BASE EXTENDER			
0266	7980000000-N	4.000 EA	\$680.2700	\$2,721.08
	GENERIC SIGNAL ITEM 5/8" X 10' GROUNDING ELECTRODE			
0267	7980000000-N	1.000 EA	\$3,527.3000	\$3,527.30
	GENERIC SIGNAL ITEM CCTV WOOD POLE			
0268	7980000000-N	1.000 EA	\$6,550.7000	\$6,550.70
	GENERIC SIGNAL ITEM DIGITAL CCTV CAMERA ASSEMBLY			

0269	7980000000-N	4.000 EA	\$2,015.6000	\$8,062.40
	GENERIC SIGNAL ITEM ETHERNET EDGE SWITCH			
0270	7980000000-N	1.000 EA	\$6,550.7000	\$6,550.70
	GENERIC SIGNAL ITEM FIELD EQUIPMENT CABINET			
0271	7980000000-N	1.000 EA	\$3,224.9500	\$3,224.95
	GENERIC SIGNAL ITEM METER BASE/DISCONNECT COMBINATION PANEL			
0272	7990000000-E	40.000 LF	\$12.0900	\$483.60
	GENERIC SIGNAL ITEM #4 SOLID BARE GROUNDING CONDUCTOR			
0273	7990000000-E	40.000 LF	\$8.0600	\$322.40
	GENERIC SIGNAL ITEM 3-WIRE COPPER FEEDER CONDUCTORS			
0274	7990000000-E	20.000 LF	\$25.1900	\$503.80
	GENERIC SIGNAL ITEM 3-WIRE COPPER SERVICE ENTRANCE CONDUCTORS			
0275	7990000000-E	830.000 LF	\$3.0100	\$2,498.30
	GENERIC SIGNAL ITEM BACK PULL FIBER OPTIC CABLE			
Section 0001 Total				\$18,286,307.79

Section 0003
WALL ITEMS

0276	8801000000-E	2815.000 SF	\$160.7700	\$452,567.55
	MSE RETAINING WALL NO **** (1)			
0277	8801000000-E	2280.000 SF	\$170.2100	\$388,078.80
	MSE RETAINING WALL NO **** (2)			
0278	8847000000-E	5095.000 SF	\$15.3600	\$78,259.20
	GENERIC RETAINING WALL ITEM ARCHITECTURAL SURFACE TREATMENT			
Section 0003 Total				\$918,905.55

Section 0004
STRUCTURE ITEMS

0279	8035000000-N	1.000 LS	\$203,597.0000	\$203,597.00
	REMOVAL OF EXISTING STRUCTURE AT STATION ***** (33+99.11 -L-)			
0280	8065000000-N	1.000 LS	\$34,722.5000	\$34,722.50
	ASBESTOS ASSESSMENT			
0281	8091000000-N	1.000 LS	\$20,997.0000	\$20,997.00
	FOUNDATION EXCAVATION FOR BENT ** AT STATION ***** (1, 33+99.11 -L-)			
0282	8091000000-N	1.000 LS	\$19,829.5000	\$19,829.50
	FOUNDATION EXCAVATION FOR BENT ** AT STATION ***** (2, 33+99.11 -L-)			
0283	8121000000-N	1.000 LS	\$7,311.3000	\$7,311.30
	UNCLASSIFIED STRUCTURE EXCAVATION AT STATION ***** (33+99.11 -L-)			
0284	8147000000-E	17988.000 SF	\$72.7200	\$1,308,087.36
	REINFORCED CONCRETE DECK SLAB			
0285	8161000000-E	17900.000 SF	\$0.6100	\$10,919.00
	GROOVING BRIDGE FLOORS			
0286	8182000000-E	367.600 CY	\$1,465.8200	\$538,835.43
	CLASS A CONCRETE (BRIDGE)			
0287	8210000000-N	1.000 LS	\$212,779.0000	\$212,779.00
	BRIDGE APPROACH SLABS, STATION ***** (33+99.11 -L-)			

0288	8217000000-E	55961.000 LB	\$1.9000	\$106,325.90
	REINFORCING STEEL (BRIDGE)			
0289	8238000000-E	3970.000 LB	\$1.7300	\$6,868.10
	SPIRAL COLUMN REINFORCING STEEL (BRIDGE)			
0290	8262000000-E	2255.460 LF	\$499.5200	\$1,126,647.38
	45" PRESTRESSED CONCRETE GIRDERS			
0291	8328200000-E	74.000 EA	\$1,749.9800	\$129,498.52
	PILE DRIVING EQUIPMENT SETUP FOR *** STEEL PILES (HP 12 X 53)			
0292	8364000000-E	5900.000 LF	\$98.0700	\$578,613.00
	HP 12 X 53 STEEL PILES			
0293	8482000000-E	397.770 LF	\$403.3900	\$160,456.44
	THREE BAR METAL RAIL			
0294	8531000000-E	61.000 SY	\$154.2600	\$9,409.86
	4" SLOPE PROTECTION			
0295	8657000000-N	1.000 LS	\$87,697.5000	\$87,697.50
	ELASTOMERIC BEARINGS			
0296	8860000000-N	1.000 LS	\$157,480.5000	\$157,480.50
	GENERIC STRUCTURE ITEM STRIP SEAL EXPANSION JOINTS			
Section 0004 Total				\$4,720,075.29
Item Total				\$23,925,288.63

ELECTRONIC BID SUBMISSION

By submitting this bid electronically, I hereby acknowledge that all requirements included in the hard copy proposal, addendum, amendments, plans, standard specifications, supplemental specifications and special provisions are part of the bid and contract. Further, I acknowledge that I have read, understand, accept, acknowledge and agree to comply with all statements in this electronic bid.

=====

NON-COLLUSION, DEBARMENT AND GIFT BAN CERTIFICATION

The prequalified bidder declares (or certifies, verifies, or states) under penalty of perjury under the laws of the United States that neither he, nor any official, agent or employee has entered into any agreement, participated in any collusion, or otherwise taken any action which is in restraint of free competitive bidding in connection with any bid or contract, that the prequalified bidder has not been convicted of violating N.C.G.S. §133-24 within the last three years, and that the prequalified bidder intends to do the work with his own bonafide employees or subcontractors and will not bid for the benefit of another contractor.

By submitting this non-collusion, debarment and gift ban certification, the Contractor is attesting his status under penalty of perjury under the laws of the United States in accordance with the Debarment Certification attached, provided that the Debarment Certification also includes any required statements concerning exceptions that are applicable.

N.C.G.S. §133-32 and Executive Order 24 prohibit the offer to, or acceptance by, any State Employee of any gift from anyone with a contract with the State, or from any person seeking to do business with the State. By execution of any response in this procurement, you attest, for your entire organization and its employees or agents, that you are not aware that any such gift has been offered, accepted, or promised by any employees of your organization.

DEBARMENT CERTIFICATION OF PREQUALIFIED BIDDER

Conditions for certification:

1. The prequalified bidder shall provide immediate written notice to the Department if at any time the bidder learns that his certification was erroneous when he submitted his debarment certification or explanation that is file with the Department, or has become erroneous because of changed circumstances.
2. The terms covered transaction, debarred, suspended, ineligible, lower tier

covered transaction, participant, person, primary covered transaction, principal, proposal, and voluntarily excluded, as used in this provision, have the meanings set out in the Definitions and Coverage sections of the rules implementing Executive Order 12549. A copy of the Federal Rules requiring this certification and detailing the definitions and coverages may be obtained from the Contract Officer of the Department.

3. The prequalified bidder agrees by submitting this form, that he will not knowingly enter into any lower tier covered transaction with a person who is debarred, suspended, declared ineligible, or voluntarily excluded from participation in NCDOT contracts, unless authorized by the Department.

4. For Federal Aid projects, the prequalified bidder further agrees that by submitting this form he will include the Federal- Aid Provision titled Required Contract Provisions Federal-Aid Construction Contract (Form FHWA PR 1273) provided by the Department, without subsequent modification, in all lower tier covered transactions.

5. The prequalified bidder may rely upon a certification of a participant in a lower tier covered transaction that he is not debarred, suspended, ineligible, or voluntarily excluded from the covered transaction, unless he knows that the certification is erroneous. The bidder may decide the method and frequency by which he will determine the eligibility of his subcontractors.

6. Nothing contained in the foregoing shall be construed to require establishment of a system of records in order to render in good faith the certification required by this provision. The knowledge and information of a participant is not required to exceed that which is normally possessed by a prudent person in the ordinary course of business dealings.

7. Except as authorized in paragraph 6 herein, the Department may terminate any contract if the bidder knowingly enters into a lower tier covered transaction with a person who is suspended, debarred, ineligible, or voluntarily excluded from participation in this transaction, in addition to other remedies available by the Federal Government.

DEBARMENT CERTIFICATION

The prequalified bidder certifies to the best of his knowledge and belief, that he and his principals:

a. Are not presently debarred, suspended, proposed for debarment, declared ineligible, or voluntarily excluded from covered transactions by any Federal department or agency;

b. Have not within a three-year period preceding this proposal been convicted of or had a civil judgment rendered against them for commission of fraud or a criminal offense in connection with obtaining, attempting to obtain, or performing a public (Federal, State or local) transaction or contract under a public transaction; violation of Federal or State antitrust statutes or

commission of embezzlement, theft, forgery, bribery, falsification or destruction of records; making false statements; or receiving stolen property;

c. Are not presently indicted for or otherwise criminally or civilly charged by a governmental entity (Federal, State or local) with commission of any of the offenses enumerated in paragraph b. of this certification; and

d. Have not within a three-year period preceding this proposal had one or more public transactions (Federal, State or local) terminated for cause or default.

e. Will submit a revised Debarment Certification immediately if his status changes and will show in his bid proposal an explanation for the change in status.

If the prequalified bidder cannot certify that he is not debarred, he shall provide an explanation with this submittal. An explanation will not necessarily result in denial of participation in a contract.

Failure to submit a non-collusion and debarment certification will result in the prequalified bidder's bid being considered non-responsive.

EXPLANATION:

=====

Award Limits on Multiple Projects

By answering YES to this statement, the bidder acknowledges that they are using the award limits on multiple projects? **Yes** **No**

A bidder who desires to bid on more than one project on which bids are to be opened on the same date, and who also desires to avoid receiving an award of more projects than he is equipped to handle, may bid on any number of projects but may limit the total amount of work awarded to him on selected projects by completing the AWARD LIMITS ON MULTIPLE PROJECTS.

The Award Limits on Multiple Projects must be filled in on each project bid for which the Bidder desires protection.

It is the desire of the Bidder to be awarded contracts, the value of which will not exceed a total of for those

projects indicated herein, for which bids will be opened on (MM/DD/YY)

The Award Limits shall apply to the following projects:

Contract Number
County

Contract Number
County

Contract Number
County

Contract Number
County

Contract Number
County

Contract Number
County

It is agreed that if I am (we are) the low Bidder(s) on indicated projects, the total value of which is more than the above stipulated award limits, the Board of Transportation will award me (us) projects from among those indicated

that have a total value not to exceed the award limit and will result in the lowest total bids to the Department of Transportation.

DBE List Summary

Project: STATE FUNDED
Bid Total: 23,925,288.63

Bidder ID: 16466
Business Name: Caton Construction Group,
Inc.

Goal: 4.00% (957,011.55)
Total Entered: 4.04% (967,124.84)

ID	Name	Is Supplier?	Item Count	Amount	Is Complete?
16042	NPS SOLUTIONS LLC	False	27	347,288.27	True
12802	NICKELSTON INDUSTRIES INC	False	13	131,385.41	True
4388	FOOTHILLS CONSTRUCTION SERVICES INC	False	20	420,512.58	True
12578	LOPEZ REBAR LLC	False	4	67,938.58	True

Name: NPS SOLUTIONS LLC ID: 16042

Address: P.O. Box 58344 RALEIGH, NC 27658

Used As: SubContractor DBE Items Total:\$347,288.27

Items for NPS SOLUTIONS LLC

0001 ROADWAY ITEMS				
0132	4650000000-N	840.000 EA	\$8.2300	\$6,913.20
	TEMPORARY RAISED PAVEMENT MARKERS			
0133	4685000000-E	18388.000 LF	\$0.8800	\$16,181.44
	THERMOPLASTIC PAVEMENT MARKING LINES (4", 90 MILS)			
0134	4688000000-E	25350.000 LF	\$1.3000	\$32,955.00
	THERMOPLASTIC PAVEMENT MARKING LINES (6", 90 MILS)			
0135	4695000000-E	4240.000 LF	\$2.3200	\$9,836.80
	THERMOPLASTIC PAVEMENT MARKING LINES (8", 90 MILS)			
0136	4700000000-E	1860.000 LF	\$2.8400	\$5,282.40
	THERMOPLASTIC PAVEMENT MARKING LINES (12", 90 MILS)			
0137	4709000000-E	1950.000 LF	\$10.0300	\$19,558.50
	THERMOPLASTIC PAVEMENT MARKING LINES (24", 90 MILS)			
0138	4720000000-E	12.000 EA	\$128.5700	\$1,542.84
	THERMOPLASTIC PAVEMENT MARKING CHARACTER (90 MILS)			
0139	4725000000-E	109.000 EA	\$159.4400	\$17,378.96
	THERMOPLASTIC PAVEMENT MARKING SYMBOL (90 MILS)			
0140	4770000000-E	1362.000 LF	\$2.8400	\$3,868.08
	COLD APPLIED PLASTIC PAVEMENT MARKING LINES, TYPE ** (4") (II)			
0141	4770000000-E	2599.000 LF	\$3.8800	\$10,084.12
	COLD APPLIED PLASTIC PAVEMENT MARKING LINES, TYPE ** (4") (IV)			
0142	4805000000-N	4.000 EA	\$1,249.7200	\$4,998.88
	COLD APPLIED PLASTIC PAVEMENT MARKING SYMBOL, TYPE ** (II)			
0143	4805000000-N	3.000 EA	\$668.5900	\$2,005.77
	COLD APPLIED PLASTIC PAVEMENT MARKING SYMBOL, TYPE ** (IV)			
0144	4810000000-E	155202.000 LF	\$0.2100	\$32,592.42
	PAINT PAVEMENT MARKING LINES (4")			
0145	4815000000-E	35352.000 LF	\$0.4600	\$16,261.92
	PAINT PAVEMENT MARKING LINES (6")			
0146	4820000000-E	19034.000 LF	\$0.6700	\$12,752.78
	PAINT PAVEMENT MARKING LINES (8")			
0147	4825000000-E	2120.000 LF	\$1.5300	\$3,243.60
	PAINT PAVEMENT MARKING LINES (12")			
0148	4835000000-E	2892.000 LF	\$2.0000	\$5,784.00
	PAINT PAVEMENT MARKING LINES (24")			
0149	4840000000-N	28.000 EA	\$36.0000	\$1,008.00
	PAINT PAVEMENT MARKING CHARACTER			

0150	4845000000-N	300.000 EA	\$46.2900	\$13,887.00
	PAINT PAVEMENT MARKING SYMBOL			
0151	4850000000-E	48050.000 LF	\$0.6700	\$32,193.50
	REMOVAL OF PAVEMENT MARKING LINES (4")			
0152	4855000000-E	19109.000 LF	\$1.0200	\$19,491.18
	REMOVAL OF PAVEMENT MARKING LINES (6")			
0153	4860000000-E	2105.000 LF	\$1.5300	\$3,220.65
	REMOVAL OF PAVEMENT MARKING LINES (8")			
0154	4865000000-E	500.000 LF	\$2.0500	\$1,025.00
	REMOVAL OF PAVEMENT MARKING LINES (12")			
0155	4870000000-E	915.000 LF	\$3.5800	\$3,275.70
	REMOVAL OF PAVEMENT MARKING LINES (24")			
0156	4875000000-N	173.000 EA	\$66.8600	\$11,566.78
	REMOVAL OF PAVEMENT MARKING SYMBOLS & CHARACTERS			
0157	4900000000-N	25.000 EA	\$8.2300	\$205.75
	PERMANENT RAISED PAVEMENT MARKERS			
0158	4905100000-N	900.000 EA	\$66.8600	\$60,174.00
	NON-CAST IRON SNOWPLOWABLE PAVEMENT MARKER			
Section 0001 Total				\$347,288.27
Item Total				\$347,288.27

Name: NICKELSTON INDUSTRIES INC ID: 12802

Address: P.O. Box 133 LAWSONVILLE, NC 27022

Used As: SubContractor DBE Items Total:\$131,385.41

Items for NICKELSTON INDUSTRIES INC

0001 ROADWAY ITEMS					
0077	3030000000-E	1737.500	LF	\$27.9300	\$48,528.38
	STEEL BEAM GUARDRAIL				
0078	3045000000-E	275.000	LF	\$30.9300	\$8,505.75
	STEEL BEAM GUARDRAIL, SHOP CURVED				
0079	3150000000-N	5.000	EA	\$54.8700	\$274.35
	ADDITIONAL GUARDRAIL POSTS				
0080	3195000000-N	1.000	EA	\$1,247.1700	\$1,247.17
	GUARDRAIL END UNITS, TYPE AT-1				
0081	3210000000-N	6.000	EA	\$1,247.1600	\$7,482.96
	GUARDRAIL END UNITS, TYPE CAT-1				
0082	3215000000-N	3.000	EA	\$2,793.6200	\$8,380.86
	GUARDRAIL ANCHOR UNITS, TYPE III				
0083	3287000000-N	5.000	EA	\$3,791.3500	\$18,956.75
	GUARDRAIL END UNITS, TYPE TL-3				
0084	3288000000-N	1.000	EA	\$3,591.8000	\$3,591.80
	GUARDRAIL END UNITS, TYPE TL-2				
0085	3317000000-N	8.000	EA	\$2,793.6000	\$22,348.80
	GUARDRAIL ANCHOR UNITS, TYPE B-77				
0086	3360000000-E	1404.000	LF	\$1.2600	\$1,769.04
	REMOVE EXISTING GUARDRAIL				
0087	3533000000-E	300.000	LF	\$23.9400	\$7,182.00
	CHAIN LINK FENCE, *** FABRIC (72")				
0088	3539000000-E	25.000	EA	\$94.7700	\$2,369.25
	METAL LINE POSTS FOR *** CHAIN LINK FENCE (72")				
0089	3545000000-E	5.000	EA	\$149.6600	\$748.30
	METAL TERMINAL POSTS FOR *** CHAIN LINK FENCE (72")				
Section 0001 Total					\$131,385.41
Item Total					\$131,385.41

Name: Foothills Construction Services Inc ID: 4388

Address: 6081 PEA RIDGE PASS HAMPTONVILLE, NC 27020

Used As: SubContractor DBE Items Total:\$420,512.58

Items for Foothills Construction Services Inc

0001 ROADWAY ITEMS					
0184	6000000000-E	14035.000	LF	\$4.3500	\$61,052.25
	TEMPORARY SILT FENCE				
0188	6015000000-E	43.000	ACR	\$1,601.3300	\$68,857.19
	TEMPORARY MULCHING				
0189	6018000000-E	2100.000	LB	\$1.9900	\$4,179.00
	SEED FOR TEMPORARY SEEDING				
0190	6021000000-E	12.500	TON	\$1,089.5200	\$13,619.00
	FERTILIZER FOR TEMPORARY SEEDING				
0192	6029000000-E	1600.000	LF	\$3.7400	\$5,984.00
	SAFETY FENCE				
0194	6036000000-E	20800.000	SY	\$1.9800	\$41,184.00
	MATTING FOR EROSION CONTROL				
0195	6037000000-E	40.000	SY	\$4.5000	\$180.00
	COIR FIBER MAT				
0196	6038000000-E	75.000	SY	\$7.3700	\$552.75
	PERMANENT SOIL REINFORCEMENT MAT				
0197	6042000000-E	8625.000	LF	\$3.7500	\$32,343.75
	1/4" HARDWARE CLOTH				
0198	6071012000-E	400.000	LF	\$11.4800	\$4,592.00
	COIR FIBER WATTLE				
0199	6071020000-E	115.000	LB	\$23.7100	\$2,726.65
	POLYACRYLAMIDE (PAM)				
0200	6071030000-E	645.000	LF	\$8.5400	\$5,508.30
	COIR FIBER BAFFLE				
0203	6084000000-E	33.000	ACR	\$4,090.6500	\$134,991.45
	SEEDING & MULCHING				
0204	6087000000-E	30.000	ACR	\$149.6600	\$4,489.80
	MOWING				
0205	6090000000-E	450.000	LB	\$4.1500	\$1,867.50
	SEED FOR REPAIR SEEDING				
0206	6093000000-E	1.250	TON	\$1,089.5200	\$1,361.90
	FERTILIZER FOR REPAIR SEEDING				
0207	6096000000-E	775.000	LB	\$4.9800	\$3,859.50
	SEED FOR SUPPLEMENTAL SEEDING				
0208	6108000000-E	23.250	TON	\$1,089.5200	\$25,331.34
	FERTILIZER TOPDRESSING				

0209	6114500000-N	10.000 MHR	\$34.9200	\$349.20
	SPECIALIZED HAND MOWING			
0212	6117000000-N	100.000 EA	\$74.8300	\$7,483.00
	RESPONSE FOR EROSION CONTROL			
Section 0001 Total				\$420,512.58
Item Total				\$420,512.58

Name: LOPEZ REBAR LLC ID: 12578

Address: 2641 EVA DRIVE NW CONCORD, NC 28027

Used As: SubContractor DBE Items Total:\$67,938.58

Items for LOPEZ REBAR LLC

0004	STRUCTURE ITEMS			
0284	8147000000-E	17988.000 SF	\$2.3100	\$41,552.28
	REINFORCED CONCRETE DECK SLAB			
0287	8210000000-N	1.000 LS	\$8,407.0000	\$8,407.00
	BRIDGE APPROACH SLABS, STATION ***** (33+99.11 -L-)			
0288	8217000000-E	55961.000 LB	\$0.3000	\$16,788.30
	REINFORCING STEEL (BRIDGE)			
0289	8238000000-E	3970.000 LB	\$0.3000	\$1,191.00
	SPIRAL COLUMN REINFORCING STEEL (BRIDGE)			
Section 0004 Total				\$67,938.58
Item Total				\$67,938.58

THIS PROPOSAL CONTAINS THE FOLLOWING ERRORS/WARNINGS (IF ANY)

This Bid contains 0 amendment files

Electronic Bid Submission

By submitting this bid electronically, I hereby acknowledge that all requirements included in the hard copy proposal, addendum, amendments, plans, standard specifications, supplemental specifications and special provisions are part of the bid and contract. Further, I acknowledge that I have read, understand, accept, acknowledge and agree to comply with all statements in this electronic bid.

I hereby certify that I have the authority to submit this bid.

Signature _____

Agency _____

Date _____

Signature _____

Agency _____

Date _____

Signature _____

Agency _____

Date _____

Attachments

Failure to complete and attach the Fuel Usage Factor Adjustment Form will result in using 2.90 gallons per ton as the Fuel Usage Factor for Diesel for the asphalt items included on the form. The contractor will not be permitted to change the option after the bids are submitted.

NOTE: The maximum upload limit is 5 MB.

Verify

Line #	ItemNumber	Sec #	Description	Quantity Unit	Unit Bid Price	Amount Bid
ROADWAY ITEMS						
0001	0000100000-N	800	MOBILIZATION	LUMP SUM	1,196,264.43	1,196,264.43
0002	0000400000-N	801	CONSTRUCTION SURVEYING	LUMP SUM	149,657.50	149,657.50
0003	0008000000-E	200	SUPPLEMENTARY CLEARING & GRUBBING	1 ACR	14,965.75	14,965.75
0004	0015000000-N	205	SEALING ABANDONED WELLS	2 EA	1,455.22	2,910.44
0005	0029000000-N	SP	TYPE III REINFORCED APPROACH FILL, STATION ***** (33+99.11 -L-)	LUMP SUM	152,434.00	152,434.00
0006	0043000000-N	226	GRADING	LUMP SUM	2,882,823.17	2,882,823.17
0007	0057000000-E	226	UNDERCUT EXCAVATION	450 CY	20.33	9,148.50
0008	0134000000-E	240	DRAINAGE DITCH EXCAVATION	290 CY	8.87	2,572.30
0009	0194000000-E	265	SELECT GRANULAR MATERIAL, CLASS III	400 CY	94.23	37,692.00
0010	0196000000-E	270	GEOTEXTILE FOR SOIL STABILIZATION	500 SY	1.44	720.00
0011	0199000000-E	SP	TEMPORARY SHORING	6,232 SF	52.47	326,993.04
0012	0318000000-E	300	FOUNDATION CONDITIONING MATERIAL, MINOR STRUCTURES	735 TON	71.31	52,412.85
0013	0320000000-E	300	FOUNDATION CONDITIONING GEOTEXTILE	2,300 SY	3.18	7,314.00
0014	0448200000-E	310	15" RC PIPE CULVERTS, CLASS IV	1,024 LF	136.21	139,479.04
0015	0448300000-E	310	18" RC PIPE CULVERTS, CLASS IV	3,746 LF	174.39	653,264.94
0016	0448400000-E	310	24" RC PIPE CULVERTS, CLASS IV	988 LF	205.39	202,925.32
0017	0448500000-E	310	30" RC PIPE CULVERTS, CLASS IV	80 LF	316.29	25,303.20
0018	0448600000-E	310	36" RC PIPE CULVERTS, CLASS IV	16 LF	247.71	3,963.36
0019	0448700000-E	310	42" RC PIPE CULVERTS, CLASS IV	288 LF	328.05	94,478.40
0020	0582000000-E	310	15" CS PIPE CULVERTS, 0.064" THICK	164 LF	90.23	14,797.72
0021	0588000000-E	310	18" CS PIPE CULVERTS, 0.064" THICK	220 LF	102.64	22,580.80
0022	0594000000-E	310	24" CS PIPE CULVERTS, 0.064" THICK	44 LF	116.21	5,113.24

Line #	ItemNumber	Sec #	Description	Quantity Unit	Unit Bid Price	Amount Bid
0023	0636000000-E	310	*** CS PIPE ELBOWS, ***** THICK (15", 0.064")	10 EA	478.15	4,781.50
0024	0636000000-E	310	*** CS PIPE ELBOWS, ***** THICK (18", 0.064")	6 EA	521.73	3,130.38
0025	0636000000-E	310	*** CS PIPE ELBOWS, ***** THICK (24", 0.064")	2 EA	672.47	1,344.94
0026	0995000000-E	340	PIPE REMOVAL	4,135 LF	49.17	203,317.95
0027	1004500000-E	505	GENERIC GRADING ITEM GEOTEXTILE FOR SUBGRADE STABILIZATION	7,200 SY	1.44	10,368.00
0028	1099500000-E	505	SHALLOW UNDERCUT	2,800 CY	36.25	101,500.00
0029	1099700000-E	505	CLASS IV SUBGRADE STABILIZATION	6,600 TON	60.51	399,366.00
0030	1220000000-E	545	INCIDENTAL STONE BASE	200 TON	63.69	12,738.00
0031	1245000000-E	SP	SHOULDER RECONSTRUCTION	3.6 SMI	58,353.50	210,072.60
0032	1260000000-E	SP	AGGREGATE SHOULDER BORROW	2,000 TON	71.39	142,780.00
0033	1297000000-E	607	MILLING ASPHALT PAVEMENT, **** DEPTH (4")	2,340 SY	7.50	17,550.00
0034	1297000000-E	607	MILLING ASPHALT PAVEMENT, **** DEPTH (6")	11,390 SY	3.43	39,067.70
0035	1330000000-E	607	INCIDENTAL MILLING	26,850 SY	3.68	98,808.00
0036	1491000000-E	610	ASPHALT CONC BASE COURSE, TYPE B25.0C	14,230 TON	90.24	1,284,115.20
0037	1503000000-E	610	ASPHALT CONC INTERMEDIATE COURSE, TYPE I19.0C	10,320 TON	90.24	931,276.80
0038	1519000000-E	610	ASPHALT CONC SURFACE COURSE, TYPE S9.5B	5,990 TON	90.24	540,537.60
0039	1523000000-E	610	ASPHALT CONC SURFACE COURSE, TYPE S9.5C	960 TON	110.31	105,897.60
0040	1575000000-E	620	ASPHALT BINDER FOR PLANT MIX	1,585 TON	852.31	1,350,911.35
0041	1577000000-E	620	POLYMER MODIFIED ASPHALT BINDER FOR PLANT MIX	55 TON	1,002.73	55,150.15
0042	1693000000-E	654	ASPHALT PLANT MIX, PAVEMENT REPAIR	800 TON	313.59	250,872.00
0043	1839140000-E	661	ULTRA-THIN BONDED WEARING COURSE	1,010 TON	175.47	177,224.70

Line #	ItemNumber	Sec #	Description	Quantity Unit	Unit Bid Price	Amount Bid
0044	1840000000-E	665	MILLED RUMBLE STRIPS (ASPHALT CONCRETE)	14,760 LF	1.32	19,483.20
0045	1891000000-E	SP	GENERIC PAVING ITEM FINE MILLING	28,650 SY	1.91	54,721.50
0046	2000000000-N	806	RIGHT-OF-WAY MARKERS	70 EA	149.66	10,476.20
0047	2022000000-E	815	SUBDRAIN EXCAVATION	44.8 CY	82.66	3,703.17
0048	2026000000-E	815	GEOTEXTILE FOR SUBSURFACE DRAINS	200 SY	21.99	4,398.00
0049	2036000000-E	815	SUBDRAIN COARSE AGGREGATE	33.6 CY	154.49	5,190.86
0050	2044000000-E	815	6" PERFORATED SUBDRAIN PIPE	200 LF	37.90	7,580.00
0051	2070000000-N	815	SUBDRAIN PIPE OUTLET	1 EA	1,605.49	1,605.49
0052	2077000000-E	815	6" OUTLET PIPE	6 LF	104.12	624.72
0053	2190000000-N	828	TEMPORARY STEEL PLATE COVERS FOR MASONRY DRAINAGE STRUCTURE	7 EA	1,212.16	8,485.12
0054	2209000000-E	838	ENDWALLS	3.4 CY	2,778.86	9,448.12
0055	2275000000-E	SP	FLOWABLE FILL	2 CY	538.37	1,076.74
0056	2286000000-N	840	MASONRY DRAINAGE STRUCTURES	112 EA	4,200.55	470,461.60
0057	2308000000-E	840	MASONRY DRAINAGE STRUCTURES	47.1 LF	850.18	40,043.48
0058	2364000000-N	840	FRAME WITH TWO GRATES, STD 840.16	26 EA	1,344.26	34,950.76
0059	2374000000-N	840	FRAME WITH GRATE & HOOD, STD 840.03, TYPE ** (E)	7 EA	1,710.38	11,972.66
0060	2374000000-N	840	FRAME WITH GRATE & HOOD, STD 840.03, TYPE ** (F)	41 EA	1,710.38	70,125.58
0061	2374000000-N	840	FRAME WITH GRATE & HOOD, STD 840.03, TYPE ** (G)	28 EA	1,710.38	47,890.64
0062	2396000000-N	840	FRAME WITH COVER, STD 840.54	12 EA	1,265.90	15,190.80
0063	2535000000-E	846	*** X *** CONCRETE CURB (8" X 12")	490 LF	33.18	16,258.20
0064	2542000000-E	846	1'-6" CONCRETE CURB & GUTTER	1,120 LF	33.18	37,161.60

Line #	ItemNumber	Sec #	Description	Quantity Unit	Unit Bid Price	Amount Bid
0065	2549000000-E	846	2'-6" CONCRETE CURB & GUTTER	10,940 LF	34.68	379,399.20
0066	2591000000-E	848	4" CONCRETE SIDEWALK	4,160 SY	40.40	168,064.00
0067	2605000000-N	848	CONCRETE CURB RAMPS	45 EA	2,793.60	125,712.00
0068	2612000000-E	848	6" CONCRETE DRIVEWAY	30 SY	49.89	1,496.70
0069	2655000000-E	852	5" MONOLITHIC CONCRETE ISLANDS (KEYED IN)	4,620 SY	79.80	368,676.00
0070	2724000000-E	857	PRECAST REINFORCED CONCRETE BARRIER, SINGLE FACED	425 LF	97.30	41,352.50
0071	2738000000-E	SP	GENERIC PAVING ITEM 9" CONCRETE TRUCK APRON	630 SY	139.67	87,992.10
0072	2753000000-E	846	GENERIC PAVING ITEM 2'-6" CONCRETE CURB AND GUTTER (MODIFIED)	240 LF	34.68	8,323.20
0073	2753000000-E	846	GENERIC PAVING ITEM CONCRETE VALLEY GUTTER (MODIFIED)	360 LF	36.19	13,028.40
0074	2830000000-N	858	ADJUSTMENT OF MANHOLES	17 EA	1,720.05	29,240.85
0075	2845000000-N	858	ADJUSTMENT OF METER BOXES OR VALVE BOXES	10 EA	1,084.12	10,841.20
0076	2950000000-N	859	CONVERT EXISTING JUNCTION BOX TO DROP INLET	1 EA	3,440.10	3,440.10
0077	3030000000-E	862	STEEL BEAM GUARDRAIL	1,737.5 LF	27.93	48,528.38
0078	3045000000-E	862	STEEL BEAM GUARDRAIL, SHOP CURVED	275 LF	30.93	8,505.75
0079	3150000000-N	862	ADDITIONAL GUARDRAIL POSTS	5 EA	54.87	274.35
0080	3195000000-N	862	GUARDRAIL END UNITS, TYPE AT-1	1 EA	1,247.17	1,247.17
0081	3210000000-N	862	GUARDRAIL END UNITS, TYPE CAT-1	6 EA	1,247.16	7,482.96
0082	3215000000-N	SP	GUARDRAIL ANCHOR UNITS, TYPE III	3 EA	2,793.62	8,380.86
0083	3287000000-N	SP	GUARDRAIL END UNITS, TYPE TL-3	5 EA	3,791.35	18,956.75
0084	3288000000-N	SP	GUARDRAIL END UNITS, TYPE TL-2	1 EA	3,591.80	3,591.80
0085	3317000000-N	SP	GUARDRAIL ANCHOR UNITS, TYPE B-77	8 EA	2,793.60	22,348.80
0086	3360000000-E	863	REMOVE EXISTING GUARDRAIL	1,404 LF	1.26	1,769.04

Line #	ItemNumber	Sec #	Description	Quantity Unit	Unit Bid Price	Amount Bid
0087	3533000000-E	866	CHAIN LINK FENCE, **** FABRIC (72")	300 LF	23.94	7,182.00
0088	3539000000-E	866	METAL LINE POSTS FOR **** CHAIN LINK FENCE (72")	25 EA	94.77	2,369.25
0089	3545000000-E	866	METAL TERMINAL POSTS FOR **** CHAIN LINK FENCE (72")	5 EA	149.66	748.30
0090	3649000000-E	876	RIP RAP, CLASS B	325 TON	83.10	27,007.50
0091	3656000000-E	876	GEOTEXTILE FOR DRAINAGE	2,330 SY	2.39	5,568.70
0092	4048000000-E	902	REINFORCED CONCRETE SIGN FOUNDATIONS	4 CY	1,197.27	4,789.08
0093	4054000000-E	902	PLAIN CONCRETE SIGN FOUNDATIONS	2 CY	798.16	1,596.32
0094	4060000000-E	903	SUPPORTS, BREAKAWAY STEEL BEAM	3,114 LB	9.97	31,046.58
0095	4066000000-E	903	SUPPORTS, SIMPLE STEEL BEAM	1,850 LB	7.99	14,781.50
0096	4072000000-E	903	SUPPORTS, 3-LB STEEL U-CHANNEL	1,450 LF	7.99	11,585.50
0097	4096000000-N	904	SIGN ERECTION, TYPE D	2 EA	299.31	598.62
0098	4102000000-N	904	SIGN ERECTION, TYPE E	76 EA	99.78	7,583.28
0099	4108000000-N	904	SIGN ERECTION, TYPE F	4 EA	124.72	498.88
0100	4110000000-N	904	SIGN ERECTION, TYPE *** (GROUND MOUNTED) (A)	10 EA	99.80	998.00
0101	4110000000-N	904	SIGN ERECTION, TYPE *** (GROUND MOUNTED) (B)	2 EA	99.79	199.58
0102	4116100000-N	904	SIGN ERECTION, RELOCATE TYPE **** (GROUND MOUNTED) (A)	5 EA	249.45	1,247.25
0103	4116100000-N	904	SIGN ERECTION, RELOCATE TYPE **** (GROUND MOUNTED) (B)	2 EA	249.44	498.88
0104	4116100000-N	904	SIGN ERECTION, RELOCATE TYPE **** (GROUND MOUNTED) (E)	7 EA	249.43	1,746.01
0105	4138000000-N	907	DISPOSAL OF SUPPORT, STEEL BEAM	7 EA	99.79	698.53

Line #	ItemNumber	Sec #	Description	Quantity Unit	Unit Bid Price	Amount Bid
0106	4152000000-N	907	DISPOSAL OF SIGN SYSTEM, STEEL BEAM	1 EA	149.69	149.69
0107	4155000000-N	907	DISPOSAL OF SIGN SYSTEM, U-CHANNEL	50 EA	99.78	4,989.00
0108	4192000000-N	907	DISPOSAL OF SUPPORT, U-CHANNEL	7 EA	99.78	698.46
0109	4400000000-E	1110	WORK ZONE SIGNS (STATIONARY)	561 SF	6.99	3,921.39
0110	4402000000-E	SP	HIGH VISIBILITY STATIONARY SIGNS	192 SF	9.18	1,762.56
0111	4405000000-E	1110	WORK ZONE SIGNS (PORTABLE)	680 SF	8.84	6,011.20
0112	4407000000-E	SP	HIGH VISIBILITY PORTABLE SIGNS	554 SF	9.73	5,390.42
0113	4410000000-E	1110	WORK ZONE SIGNS (BARRICADE MOUNTED)	54 SF	9.48	511.92
0114	4415000000-N	1115	FLASHING ARROW BOARD	5 EA	2,394.53	11,972.65
0115	4420000000-N	1120	PORTABLE CHANGEABLE MESSAGE SIGN	4 EA	10,376.25	41,505.00
0116	4430000000-N	1130	DRUMS	300 EA	45.89	13,767.00
0117	4432000000-N	SP	HIGH VISIBILITY DRUMS	182 EA	59.35	10,801.70
0118	4434000000-N	SP	SEQUENTIAL FLASHING WARNING LIGHTS	12 EA	139.67	1,676.04
0119	4435000000-N	1135	CONES	100 EA	21.95	2,195.00
0120	4445000000-E	1145	BARRICADES (TYPE III)	56 LF	25.94	1,452.64
0121	4447000000-E	SP	PEDESTRIAN CHANNELIZING DEVICES	314 LF	74.83	23,496.62
0122	4455000000-N	1150	FLAGGER	390 DAY	368.22	143,605.80
0123	4465000000-N	1160	TEMPORARY CRASH CUSHIONS	9 EA	11,366.25	102,296.25
0124	4470000000-N	1160	REMOVE & RESET TEMPORARY CRASH CUSHION	1 EA	2,980.55	2,980.55
0125	4480000000-N	1165	TMA	2 EA	52,679.50	105,359.00
0126	4485000000-E	1170	PORTABLE CONCRETE BARRIER	1,720 LF	50.62	87,066.40
0127	4490000000-E	1170	PORTABLE CONCRETE BARRIER (ANCHORED)	200 LF	72.69	14,538.00
0128	4505000000-E	1170	REMOVE & RESET PORTABLE CONCRETE BARRIER (ANCHORED)	550 LF	25.24	13,882.00

Line #	ItemNumber	Sec #	Description	Quantity Unit	Unit Bid Price	Amount Bid
0129	4510000000-N	1190	LAW ENFORCEMENT	240 HR	99.78	23,947.20
0130	4600000000-N	SP	GENERIC TRAFFIC CONTROL ITEM AUDIBLE WARNING DEVICES	3 EA	384.12	1,152.36
0131	4600000000-N	SP	GENERIC TRAFFIC CONTROL ITEM PEDESTRIAN TRANSPORT SERVICE (PER TRIP)	300 EA	149.66	44,898.00
0132	4650000000-N	1251	TEMPORARY RAISED PAVEMENT MARKERS	840 EA	8.23	6,913.20
0133	4685000000-E	1205	THERMOPLASTIC PAVEMENT MARKING LINES (4", 90 MILS)	18,388 LF	0.88	16,181.44
0134	4688000000-E	1205	THERMOPLASTIC PAVEMENT MARKING LINES (6", 90 MILS)	25,350 LF	1.30	32,955.00
0135	4695000000-E	1205	THERMOPLASTIC PAVEMENT MARKING LINES (8", 90 MILS)	4,240 LF	2.32	9,836.80
0136	4700000000-E	1205	THERMOPLASTIC PAVEMENT MARKING LINES (12", 90 MILS)	1,860 LF	2.84	5,282.40
0137	4709000000-E	1205	THERMOPLASTIC PAVEMENT MARKING LINES (24", 90 MILS)	1,950 LF	10.03	19,558.50
0138	4720000000-E	1205	THERMOPLASTIC PAVEMENT MARKING CHARACTER (90 MILS)	12 EA	128.57	1,542.84
0139	4725000000-E	1205	THERMOPLASTIC PAVEMENT MARKING SYMBOL (90 MILS)	109 EA	159.44	17,378.96
0140	4770000000-E	1205	COLD APPLIED PLASTIC PAVEMENT MARKING LINES, TYPE ** (4") (II)	1,362 LF	2.84	3,868.08
0141	4770000000-E	1205	COLD APPLIED PLASTIC PAVEMENT MARKING LINES, TYPE ** (4") (IV)	2,599 LF	3.88	10,084.12
0142	4805000000-N	1205	COLD APPLIED PLASTIC PAVEMENT MARKING SYMBOL, TYPE ** (II)	4 EA	1,249.72	4,998.88
0143	4805000000-N	1205	COLD APPLIED PLASTIC PAVEMENT MARKING SYMBOL, TYPE ** (IV)	3 EA	668.59	2,005.77
0144	4810000000-E	1205	PAINT PAVEMENT MARKING LINES (4")	155,202 LF	0.21	32,592.42
0145	4815000000-E	1205	PAINT PAVEMENT MARKING LINES (6")	35,352 LF	0.46	16,261.92
0146	4820000000-E	1205	PAINT PAVEMENT MARKING LINES (8")	19,034 LF	0.67	12,752.78
0147	4825000000-E	1205	PAINT PAVEMENT MARKING LINES (12")	2,120 LF	1.53	3,243.60
0148	4835000000-E	1205	PAINT PAVEMENT MARKING LINES (24")	2,892 LF	2.00	5,784.00

Line #	ItemNumber	Sec #	Description	Quantity Unit	Unit Bid Price	Amount Bid
0149	4840000000-N	1205	PAINT PAVEMENT MARKING CHARACTER	28 EA	36.00	1,008.00
0150	4845000000-N	1205	PAINT PAVEMENT MARKING SYMBOL	300 EA	46.29	13,887.00
0151	4850000000-E	1205	REMOVAL OF PAVEMENT MARKING LINES (4")	48,050 LF	0.67	32,193.50
0152	4855000000-E	1205	REMOVAL OF PAVEMENT MARKING LINES (6")	19,109 LF	1.02	19,491.18
0153	4860000000-E	1205	REMOVAL OF PAVEMENT MARKING LINES (8")	2,105 LF	1.53	3,220.65
0154	4865000000-E	1205	REMOVAL OF PAVEMENT MARKING LINES (12")	500 LF	2.05	1,025.00
0155	4870000000-E	1205	REMOVAL OF PAVEMENT MARKING LINES (24")	915 LF	3.58	3,275.70
0156	4875000000-N	1205	REMOVAL OF PAVEMENT MARKING SYMBOLS & CHARACTERS	173 EA	66.86	11,566.78
0157	4900000000-N	1251	PERMANENT RAISED PAVEMENT MARKERS	25 EA	8.23	205.75
0158	4905100000-N	SP	NON-CAST IRON SNOWPLOWABLE PAVEMENT MARKER	900 EA	66.86	60,174.00
0159	5255000000-N	1413	PORTABLE LIGHTING	LUMP SUM	55,361.00	55,361.00
0160	5325600000-E	1510	6" WATER LINE	184 LF	329.91	60,703.44
0161	5326200000-E	1510	12" WATER LINE	270 LF	294.38	79,482.60
0162	5326600000-E	1510	16" WATER LINE	353 LF	422.19	149,033.07
0163	5329000000-E	1510	DUCTILE IRON WATER PIPE FITTINGS	10,695 LB	10.47	111,976.65
0164	5540000000-E	1515	6" VALVE	4 EA	3,188.15	12,752.60
0165	5558000000-E	1515	12" VALVE	2 EA	7,696.25	15,392.50
0166	5558600000-E	1515	16" VALVE	1 EA	19,300.25	19,300.25
0167	5648000000-N	1515	RELOCATE WATER METER	14 EA	3,104.25	43,459.50
0168	5649000000-N	1515	RECONNECT WATER METER	3 EA	2,502.75	7,508.25
0169	5656100000-E	1515	RELOCATE **** RPZ BACKFLOW PREVENTION ASSEMBLY (1")	4 EA	2,179.52	8,718.08
0170	5656210000-E	1515	RELOCATE 2" RPZ BACKFLOW PREVENTION ASSEMBLY	1 EA	2,792.25	2,792.25

Line #	ItemNumber	Sec #	Description	Quantity Unit	Unit Bid Price	Amount Bid
0171	5666000000-N	1515	FIRE HYDRANT	3 EA	9,853.65	29,560.95
0172	5672000000-N	1515	RELOCATE FIRE HYDRANT	2 EA	2,218.49	4,436.98
0173	5673000000-E	1515	FIRE HYDRANT LEG	237 LF	239.90	56,856.30
0174	5686500000-E	1515	WATER SERVICE LINE	827 LF	85.22	70,476.94
0175	5691300000-E	1520	8" SANITARY GRAVITY SEWER	195 LF	241.67	47,125.65
0176	5768000000-N	1520	SANITARY SEWER CLEAN-OUT	11 EA	6,097.55	67,073.05
0177	5768500000-E	1520	SEWER SERVICE LINE	194 LF	164.50	31,913.00
0178	5775000000-E	1525	4' DIA UTILITY MANHOLE	3 EA	7,711.90	23,135.70
0179	5781000000-E	1525	UTILITY MANHOLE WALL 4' DIA	8 LF	313.73	2,509.84
0180	5800000000-E	1530	ABANDON 6" UTILITY PIPE	714 LF	47.82	34,143.48
0181	5801000000-E	1530	ABANDON 8" UTILITY PIPE	161 LF	79.68	12,828.48
0182	5804000000-E	1530	ABANDON 12" UTILITY PIPE	260 LF	78.40	20,384.00
0183	5816000000-N	1530	ABANDON UTILITY MANHOLE	3 EA	1,141.06	3,423.18
0184	6000000000-E	1605	TEMPORARY SILT FENCE	14,035 LF	4.35	61,052.25
0185	6006000000-E	1610	STONE FOR EROSION CONTROL, CLASS A	700 TON	70.92	49,644.00
0186	6009000000-E	1610	STONE FOR EROSION CONTROL, CLASS B	1,360 TON	75.65	102,884.00
0187	6012000000-E	1610	SEDIMENT CONTROL STONE	2,255 TON	57.81	130,361.55
0188	6015000000-E	1615	TEMPORARY MULCHING	43 ACR	1,601.33	68,857.19
0189	6018000000-E	1620	SEED FOR TEMPORARY SEEDING	2,100 LB	1.99	4,179.00
0190	6021000000-E	1620	FERTILIZER FOR TEMPORARY SEEDING	12.5 TON	1,089.52	13,619.00
0191	6024000000-E	1622	TEMPORARY SLOPE DRAINS	635 LF	16.50	10,477.50
0192	6029000000-E	SP	SAFETY FENCE	1,600 LF	3.74	5,984.00
0193	6030000000-E	1630	SILT EXCAVATION	4,270 CY	1.90	8,113.00

Line #	ItemNumber	Sec #	Description	Quantity Unit	Unit Bid Price	Amount Bid
0194	6036000000-E	1631	MATTING FOR EROSION CONTROL	20,800 SY	1.98	41,184.00
0195	6037000000-E	SP	COIR FIBER MAT	40 SY	4.50	180.00
0196	6038000000-E	SP	PERMANENT SOIL REINFORCEMENT MAT	75 SY	7.37	552.75
0197	6042000000-E	1632	1/4" HARDWARE CLOTH	8,625 LF	3.75	32,343.75
0198	6071012000-E	SP	COIR FIBER WATTLE	400 LF	11.48	4,592.00
0199	6071020000-E	SP	POLYACRYLAMIDE (PAM)	115 LB	23.71	2,726.65
0200	6071030000-E	1640	COIR FIBER BAFFLE	645 LF	8.54	5,508.30
0201	6071050000-E	SP	*** SKIMMER (1-1/2")	2 EA	2,904.06	5,808.12
0202	6071050000-E	SP	*** SKIMMER (2")	1 EA	3,067.15	3,067.15
0203	6084000000-E	1660	SEEDING & MULCHING	33 ACR	4,090.65	134,991.45
0204	6087000000-E	1660	MOWING	30 ACR	149.66	4,489.80
0205	6090000000-E	1661	SEED FOR REPAIR SEEDING	450 LB	4.15	1,867.50
0206	6093000000-E	1661	FERTILIZER FOR REPAIR SEEDING	1.25 TON	1,089.52	1,361.90
0207	6096000000-E	1662	SEED FOR SUPPLEMENTAL SEEDING	775 LB	4.98	3,859.50
0208	6108000000-E	1665	FERTILIZER TOPDRESSING	23.25 TON	1,089.52	25,331.34
0209	6114500000-N	1667	SPECIALIZED HAND MOWING	10 MHR	34.92	349.20
0210	6114800000-N	SP	MANUAL LITTER REMOVAL	17 MHR	149.66	2,544.22
0211	6114900000-E	SP	LITTER DISPOSAL	2 TON	149.65	299.30
0212	6117000000-N	SP	RESPONSE FOR EROSION CONTROL	100 EA	74.83	7,483.00
0213	6117500000-N	SP	CONCRETE WASHOUT STRUCTURE	10 EA	498.86	4,988.60
0214	6132000000-N	SP	GENERIC EROSION CONTROL ITEM FABRIC INSERT INLET PROTECTION DEVICE	108 EA	174.60	18,856.80
0215	6132000000-N	SP	GENERIC EROSION CONTROL ITEM FABRIC INSERT INLET PROTECTION DEVICE CLEANOUT	324 EA	174.60	56,570.40

Line #	ItemNumber	Sec #	Description	Quantity Unit	Unit Bid Price	Amount Bid
0216	7048500000-E	1705	PEDESTRIAN SIGNAL HEAD (16", 1 SECTION W/COUNTDOWN)	20 EA	1,048.12	20,962.40
0217	7060000000-E	1705	SIGNAL CABLE	9,225 LF	3.51	32,379.75
0218	7120000000-E	1705	VEHICLE SIGNAL HEAD (12", 3 SECTION)	60 EA	967.48	58,048.80
0219	7132000000-E	1705	VEHICLE SIGNAL HEAD (12", 4 SECTION)	9 EA	1,224.46	11,020.14
0220	7144000000-E	1705	VEHICLE SIGNAL HEAD (12", 5 SECTION)	9 EA	1,662.86	14,965.74
0221	7252000000-E	1710	MESSENGER CABLE (1/4")	3,375 LF	3.51	11,846.25
0222	7264000000-E	1710	MESSENGER CABLE (3/8")	3,585 LF	5.54	19,860.90
0223	7279000000-E	1715	TRACER WIRE	2,270 LF	1.01	2,292.70
0224	7288000000-E	1715	PAVED TRENCHING (*****) (1, 2")	100 LF	58.45	5,845.00
0225	7300000000-E	1715	UNPAVED TRENCHING (*****) (1, 2")	1,865 LF	9.56	17,829.40
0226	7300000000-E	1715	UNPAVED TRENCHING (*****) (2, 2")	20 LF	30.24	604.80
0227	7300000000-E	1715	UNPAVED TRENCHING (*****) (3, 2")	115 LF	35.28	4,057.20
0228	7301000000-E	1715	DIRECTIONAL DRILL (*****) (1, 2")	405 LF	20.16	8,164.80
0229	7301000000-E	1715	DIRECTIONAL DRILL (*****) (2, 2")	925 LF	24.70	22,847.50
0230	7301000000-E	1715	DIRECTIONAL DRILL (*****) (3, 2")	1,050 LF	26.20	27,510.00
0231	7312000000-N	1716	JUNCTION BOX (*****) (SPECIAL OVERSIZED, HEAVY DUTY, 36" X 24" X 24")	6 EA	2,297.77	13,786.62
0232	7324000000-N	1716	JUNCTION BOX (STANDARD SIZE)	31 EA	564.37	17,495.47
0233	7348000000-N	1716	JUNCTION BOX (OVER-SIZED, HEAVY DUTY)	13 EA	1,098.51	14,280.63
0234	7360000000-N	1720	WOOD POLE	4 EA	1,310.14	5,240.56
0235	7372000000-N	1721	GUY ASSEMBLY	33 EA	907.02	29,931.66
0236	7396000000-E	1722	1/2" RISER WITH WEATHERHEAD	7 EA	403.12	2,821.84
0237	7408000000-E	1722	1" RISER WITH WEATHERHEAD	5 EA	503.88	2,519.40

Line #	ItemNumber	Sec #	Description	Quantity Unit	Unit Bid Price	Amount Bid
0238	7420000000-E	1722	2" RISER WITH WEATHERHEAD	8 EA	1,007.80	8,062.40
0239	7432000000-E	1722	2" RISER WITH HEAT SHRINK TUBING	12 EA	1,209.36	14,512.32
0240	7444000000-E	1725	INDUCTIVE LOOP SAWCUT	5,475 LF	10.08	55,188.00
0241	7456000000-E	1726	LEAD-IN CABLE (***** (14-2)	27,357 LF	2.01	54,987.57
0242	7481000000-N	SP	SITE SURVEY	4 EA	1,007.80	4,031.20
0243	7481200000-N	SP	LUMINAIRE ARM FOR VIDEO SYSTEM	11 EA	1,158.98	12,748.78
0244	7481240000-N	SP	CAMERA WITHOUT INTERNAL LOOP EMULATOR PROCESSING UNIT	10 EA	6,248.40	62,484.00
0245	7481260000-N	SP	EXTERNAL LOOP EMULATOR PROCESSING UNIT	4 EA	4,635.85	18,543.40
0246	7516000000-E	1730	COMMUNICATIONS CABLE (** FIBER) (24)	5,400 LF	3.30	17,820.00
0247	7516000000-E	1730	COMMUNICATIONS CABLE (** FIBER) (96)	6,650 LF	4.43	29,459.50
0248	7528000000-E	1730	DROP CABLE	2,535 LF	3.51	8,897.85
0249	7540000000-N	1731	SPLICE ENCLOSURE	10 EA	5,190.20	51,902.00
0250	7541000000-N	1731	MODIFY SPLICE ENCLOSURE	3 EA	1,511.70	4,535.10
0251	7552000000-N	1731	INTERCONNECT CENTER	5 EA	1,814.03	9,070.15
0252	7566000000-N	1733	DELINEATOR MARKER	13 EA	138.08	1,795.04
0253	7575160000-E	1734	REMOVE EXISTING COMMUNICATIONS CABLE	4,750 LF	1.51	7,172.50
0254	7575180000-N	1735	CABLE TRANSFER	2 EA	503.89	1,007.78
0255	7576000000-N	SP	METAL STRAIN SIGNAL POLE	12 EA	14,209.75	170,517.00
0256	7613000000-N	SP	SOIL TEST	12 EA	1,310.14	15,721.68
0257	7614100000-E	SP	DRILLED PIER FOUNDATION	72 CY	1,536.90	110,656.80
0258	7636000000-N	1745	SIGN FOR SIGNALS	25 EA	503.88	12,597.00
0259	7642100000-N	1743	TYPE I POST WITH FOUNDATION	8 EA	1,763.63	14,109.04
0260	7642200000-N	1743	TYPE II PEDESTAL WITH FOUNDATION	11 EA	2,922.57	32,148.27

Line #	ItemNumber	Sec #	Description	Quantity Unit	Unit Bid Price	Amount Bid
0261	7684000000-N	1750	SIGNAL CABINET FOUNDATION	3 EA	3,023.40	9,070.20
0262	7696000000-N	1751	CONTROLLERS WITH CABINET (***** (2070E, BASE MOUNTED)	3 EA	20,155.75	60,467.25
0263	7696000000-N	1751	CONTROLLERS WITH CABINET (***** (2070E, POLE MOUNTED)	1 EA	18,140.25	18,140.25
0264	7744000000-N	1751	DETECTOR CARD (TYPE 170)	36 EA	251.95	9,070.20
0265	7901000000-N	1753	CABINET BASE EXTENDER	3 EA	725.62	2,176.86
0266	7980000000-N	SP	GENERIC SIGNAL ITEM 5/8" X 10' GROUNDING ELECTRODE	4 EA	680.27	2,721.08
0267	7980000000-N	SP	GENERIC SIGNAL ITEM CCTV WOOD POLE	1 EA	3,527.30	3,527.30
0268	7980000000-N	SP	GENERIC SIGNAL ITEM DIGITAL CCTV CAMERA ASSEMBLY	1 EA	6,550.70	6,550.70
0269	7980000000-N	SP	GENERIC SIGNAL ITEM ETHERNET EDGE SWITCH	4 EA	2,015.60	8,062.40
0270	7980000000-N	SP	GENERIC SIGNAL ITEM FIELD EQUIPMENT CABINET	1 EA	6,550.70	6,550.70
0271	7980000000-N	SP	GENERIC SIGNAL ITEM METER BASE/DISCONNECT COMBINATION PANEL	1 EA	3,224.95	3,224.95
0272	7990000000-E	SP	GENERIC SIGNAL ITEM #4 SOLID BARE GROUNDING CONDUCTOR	40 LF	12.09	483.60
0273	7990000000-E	SP	GENERIC SIGNAL ITEM 3-WIRE COPPER FEEDER CONDUCTORS	40 LF	8.06	322.40
0274	7990000000-E	SP	GENERIC SIGNAL ITEM 3-WIRE COPPER SERVICE ENTRANCE CONDUCTORS	20 LF	25.19	503.80
0275	7990000000-E	SP	GENERIC SIGNAL ITEM BACK PULL FIBER OPTIC CABLE	830 LF	3.01	2,498.30

Contract Item Sheets For C204837

Line #	ItemNumber	Sec #	Description	Quantity Unit	Unit Bid Price	Amount Bid
WALL ITEMS						
0276	8801000000-E	SP	MSE RETAINING WALL NO **** (1)	2,815 SF	160.77	452,567.55
0277	8801000000-E	SP	MSE RETAINING WALL NO **** (2)	2,280 SF	170.21	388,078.80
0278	8847000000-E	SP	GENERIC RETAINING WALL ITEM ARCHITECTURAL SURFACE TREATMENT	5,095 SF	15.36	78,259.20

Line #	ItemNumber	Sec #	Description	Quantity Unit	Unit Bid Price	Amount Bid
STRUCTURE ITEMS						
0279	8035000000-N	402	REMOVAL OF EXISTING STRUCTURE AT STATION ***** (33+99.11 -L-)	LUMP SUM	203,597.00	203,597.00
0280	8065000000-N	SP	ASBESTOS ASSESSMENT	LUMP SUM	34,722.50	34,722.50
0281	8091000000-N	410	FOUNDATION EXCAVATION FOR BENT ** AT STATION ***** (1, 33+99.11 -L-)	LUMP SUM	20,997.00	20,997.00
0282	8091000000-N	410	FOUNDATION EXCAVATION FOR BENT ** AT STATION ***** (2, 33+99.11 -L-)	LUMP SUM	19,829.50	19,829.50
0283	8121000000-N	412	UNCLASSIFIED STRUCTURE EXCAVATION AT STATION ***** (33+99.11 -L-)	LUMP SUM	7,311.30	7,311.30
0284	8147000000-E	420	REINFORCED CONCRETE DECK SLAB	17,988 SF	72.72	1,308,087.36
0285	8161000000-E	420	GROOVING BRIDGE FLOORS	17,900 SF	0.61	10,919.00
0286	8182000000-E	420	CLASS A CONCRETE (BRIDGE)	367.6 CY	1,465.82	538,835.43
0287	8210000000-N	422	BRIDGE APPROACH SLABS, STATION ***** (33+99.11 -L-)	LUMP SUM	212,779.00	212,779.00
0288	8217000000-E	425	REINFORCING STEEL (BRIDGE)	55,961 LB	1.90	106,325.90
0289	8238000000-E	425	SPIRAL COLUMN REINFORCING STEEL (BRIDGE)	3,970 LB	1.73	6,868.10
0290	8262000000-E	430	45" PRESTRESSED CONCRETE GIRDERS	2,255.46 LF	499.52	1,126,647.38
0291	8328200000-E	450	PILE DRIVING EQUIPMENT SETUP FOR *** STEEL PILES (HP 12 X 53)	74 EA	1,749.98	129,498.52
0292	8364000000-E	450	HP 12 X 53 STEEL PILES	5,900 LF	98.07	578,613.00
0293	8482000000-E	460	THREE BAR METAL RAIL	397.77 LF	403.39	160,456.44
0294	8531000000-E	462	4" SLOPE PROTECTION	61 SY	154.26	9,409.86
0295	8657000000-N	430	ELASTOMERIC BEARINGS	LUMP SUM	87,697.50	87,697.50
0296	8860000000-N	SP	GENERIC STRUCTURE ITEM STRIP SEAL EXPANSION JOINTS	LUMP SUM	157,480.50	157,480.50

TOTAL AMOUNT OF BID FOR ENTIRE PROJECT

\$23,925,288.63

Contract Number	C204837
TIP Number	U-2729
County and Route	Forsyth / SR 1672 from Museum Drive to SR 4000 (University Parkway) in Winston-Salem

Bid Items Eligible for Steel Price Adjustment

Instructions: This form shall be completed in accordance with the Special Provision. If you choose to have Steel Price Adjustments applied to any of the items listed below, write the word "Yes" in the "Option" column corresponding to the item. The form must be signed, dated, and submitted to the Contract Engineer within timeframe required by the Special Provision.

Contract Line Number	Item Number	Description	Category	Option (Yes or No)
0077	3030000000-E	STEEL BEAM GUARDRAIL,	4	No
0078	3045000000-E	STEEL BEAM GUARDRAIL, SHOP CURVED,	4	No
0079	3150000000-N	ADDITIONAL GUARDRAIL POSTS,	4	No
0080	3195000000-N	GUARDRAIL END UNITS, TYPE AT-1,	4	No
0081	3210000000-N	GUARDRAIL END UNITS, TYPE CAT-1,	4	No
0082	3215000000-N	GUARDRAIL ANCHOR UNITS, TYPE III,	4	No
0083	3287000000-N	GUARDRAIL END UNITS, TYPE TL-3,	4	No
0084	3288000000-N	GUARDRAIL END UNITS, TYPE TL-2,	4	No
0085	3317000000-N	GUARDRAIL ANCHOR UNITS, TYPE B-77,	4	No
0087	3533000000-E	CHAIN LINK FENCE, ** FABRIC,	5	No
0088	3539000000-E	METAL LINE POSTS FOR ** CHAINLINK FENCE,"	5	No
0089	3545000000-E	METAL TERMINAL POSTS FOR ** CHAIN LINK FENCE,"	5	No
0094	4060000000-E	SUPPORTS, BREAKAWAY STEEL BEAM,	5	No
0095	4066000000-E	SUPPORTS, SIMPLE STEEL BEAM,	5	No
0096	4072000000-E	SUPPORTS, 3-LB STEEL U-CHANNEL,	5	No
0255	7576000000-N	METAL STRAIN SIGNAL POLE,	6	No
0284	8147000000-E	REINFORCED CONCRETE DECK SLAB,	1	No
0287	8210000000-N	BRIDGE APPROACH SLABS, STATION*****,	1	No
0288	8217000000-E	REINFORCING STEEL (BRIDGE),	1	No
0289	8238000000-E	SPIRAL COLUMN REINFORCING STEEL (BRIDGE),	1	No
0290	8262000000-E	45 PRESTRESSED CONCRETE GIRDERS,"	7	No
0292	8364000000-E	HP12X53 STEEL PILES,	3	No
Signature				
 Matthew G. Shaw <small>Matthew G. Shaw, President, Caton Construction Group, Inc. 10000 University Parkway, Suite 1000, Winston-Salem, NC 27157 Phone: 703.222.2777 Fax: 703.222.2400</small>		Firm or Corporation Caton Construction Group, Inc.		
Date:		Vendor Number 16466		

Contract No. C204837
County FORSYTH

Rev. 1-16-18

**EXECUTION OF CONTRACT
NON-COLLUSION, DEBARMENT AND GIFT BAN CERTIFICATION**

CORPORATION

The Contractor declares (or certifies, verifies, or states) under penalty of perjury under the laws of the United States that neither he, nor any official, agent or employee has entered into any agreement, participated in any collusion, or otherwise taken any action which is in restraint of free competitive bidding in connection with this Contract, that the Contractor has not been convicted of violating N.C.G.S. § 133-24 within the last three years, and that the Contractor intends to do the work with its own bona fide employees or subcontractors and did not bid for the benefit of another contractor.

By submitting this Execution of Contract, Non-Collusion and Debarment Certification, the Contractor is certifying his status under penalty of perjury under the laws of the United States in accordance with the Debarment Certification attached, provided that the Debarment Certification also includes any required statements concerning exceptions that are applicable.

N.C.G.S. § 133-32 and Executive Order 24 prohibit the offer to, or acceptance by, any State Employee of any gift from anyone with a contract with the State, or from any person seeking to do business with the State. By execution of any response in this procurement, you attest, for your entire organization and its employees or agents, that you are not aware that any such gift has been offered, accepted, or promised by any employees of your organization.

**SIGNATURE OF CONTRACTOR
CATON CONSTRUCTION GROUP, INC.**

Full name of Corporation

P.O. BOX 4488, CHARLOTTESVILLE, VA 22905

Address as Prequalified

Attest Dean T. Wenger
Secretary/Assistant Secretary
Select appropriate title

DEAN T. WENGER

Print or type Signer's name

By [Signature]
~~President/Vice President/Assistant Vice President~~
Select appropriate title

DIANE E. CATON

Print or type Signer's name

CORPORATE SEAL

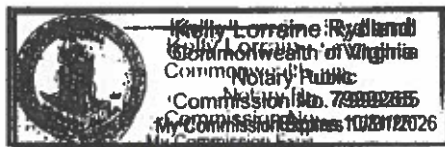

Kelly Rydland



DEBARMENT CERTIFICATION

Conditions for certification:

1. The prequalified bidder shall provide immediate written notice to the Department if at any time the bidder learns that his certification was erroneous when he submitted his debarment certification or explanation filed with the Department, or has become erroneous because of changed circumstances.
2. The terms *covered transaction, debarred, suspended, ineligible, lower tier covered transaction, participant, person, primary covered transaction, principal, proposal, and voluntarily excluded*, as used in this provision, have the meanings set out in the Definitions and Coverage sections of the rules implementing Executive Order 12549. A copy of the Federal Rules requiring this certification and detailing the definitions and coverages may be obtained from the Contract Officer of the Department.
3. The prequalified bidder agrees by submitting this form, that he will not knowingly enter into any lower tier covered transaction with a person who is debarred, suspended, declared ineligible, or voluntarily excluded from participation in NCDOT contracts, unless authorized by the Department.
4. For Federal Aid projects, the prequalified bidder further agrees that by submitting this form he will include the Federal-Aid Provision titled *Required Contract Provisions Federal-Aid Construction Contract (Form FHWA PR 1273)* provided by the Department, without subsequent modification, in all lower tier covered transactions.
5. The prequalified bidder may rely upon a certification of a participant in a lower tier covered transaction that he is not debarred, suspended, ineligible, or voluntarily excluded from the covered transaction, unless he knows that the certification is erroneous. The bidder may decide the method and frequency by which he will determine the eligibility of his subcontractors.
6. Nothing contained in the foregoing shall be construed to require establishment of a system of records in order to render in good faith the certification required by this provision. The knowledge and information of a participant is not required to exceed that which is normally possessed by a prudent person in the ordinary course of business dealings.
7. Except as authorized in paragraph 6 herein, the Department may terminate any contract if the bidder knowingly enters into a lower tier covered transaction with a person who is suspended, debarred, ineligible, or voluntarily excluded from participation in this transaction, in addition to other remedies available by the Federal Government.

DEBARMENT CERTIFICATION

The prequalified bidder certifies to the best of his knowledge and belief, that he and his principals:

- a. Are not presently debarred, suspended, proposed for debarment, declared ineligible, or voluntarily excluded from covered transactions by any Federal department or agency;
- b. Have not within a three-year period preceding this proposal been convicted of or had a civil judgment rendered against them for commission of fraud or a criminal offense in connection with obtaining, attempting to obtain, or performing a public (Federal, State or local) transaction or contract under a public transaction; violation of Federal or State antitrust statutes or commission of embezzlement, theft, forgery, bribery, falsification or destruction of records; making false statements; or receiving stolen property;
- c. Are not presently indicted for or otherwise criminally or civilly charged by a governmental entity (Federal, State or local) with commission of any of the offenses enumerated in paragraph b. of this certification; and
- d. Have not within a three-year period preceding this proposal had one or more public transactions (Federal, State or local) terminated for cause or default.
- e. Will submit a revised Debarment Certification immediately if his status changes and will show in his bid proposal an explanation for the change in status.

If the prequalified bidder cannot certify that he is not debarred, he shall provide an explanation with this submittal. An explanation will not necessarily result in denial of participation in a contract.

Failure to submit a non-collusion and debarment certification will result in the prequalified bidder's bid being considered non-responsive.

Check here if an explanation is attached to this certification.

Contract No. **C204837**

County (ies): **Forsyth**

ACCEPTED BY THE
DEPARTMENT OF TRANSPORTATION

DocuSigned by:

Ronald E. Davenport, Jr.

F81B6038A47A442...

Contract Officer

07/21/2023

Date

Execution of Contract and Bonds
Approved as to Form:

DocuSigned by:

Colin Justice

1889E4C5ADF14AE...

Attorney General

07/21/2023

Date

Contract No. C204837
County FORSYTH

Rev 5-17-11

Bond No. 4467794

CONTRACT PAYMENT BOND

Date of Payment Bond Execution July 11, 2023
Name of Principal Contractor Caton Construction Group, Inc.
Name of Surety: Markel Insurance Company
Name of Contracting Body: North Carolina Department of Transportation
Raleigh, North Carolina
Amount of Bond: \$23,925,288.63
Contract ID No.: C204837
County Name: Forsyth

KNOW ALL MEN BY THESE PRESENTS, That we, the PRINCIPAL CONTRACTOR (hereafter, PRINCIPAL) and SURETY above named, are held and firmly bound unto the above named Contracting Body, hereinafter called the Contracting Body, in the penal sum of the amount stated above for the payment of which sum well and truly to be made, we bind ourselves, our heirs, executors, administrators, and successors, jointly and severally, firmly by these presents.

THE CONDITION OF THIS OBLIGATION IS SUCH, that whereas the principal entered into a certain contract with the Contracting Body, numbered as shown above and hereto attached:

NOW THEREFORE, if the principal shall promptly make payment to all persons supplying labor and material in the prosecution of the work provided for in said contract, and any and all duly authorized modifications of said contract that may hereafter be made, notice of which modifications to the surety being hereby waived, then this obligation to be void; otherwise to remain in full force and virtue.

IN WITNESS WHEREOF, the above-bound parties have executed this instrument under their several seals on the date indicated above, the name and corporate seal of each corporate party being hereto affixed and these presents duly signed by its undersigned representative, pursuant to authority of its governing body.

Contract No. C204837
County Forsyth

Rev 5-17-11

CONTRACT PAYMENT BOND

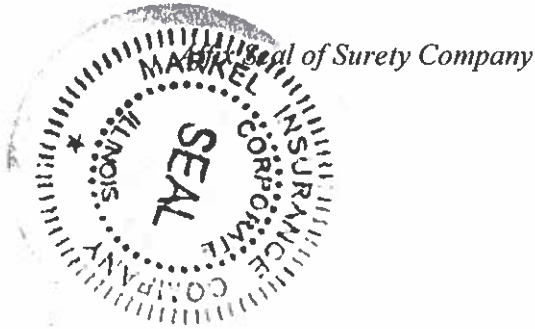

Markel Insurance Company
Print or type Surety Company Name

By Theresa S. Stump, Attorney-In-Fact
Print, stamp or type name of Attorney-in-Fact

Theresa S. Stump
Signature of Attorney-in-Fact

[Handwritten Signature]
Signature of Witness

Deanna W. Sparks, Witness
Print or type Signer's name

10 Franklin Road, S.E., Suite 550, Roanoke, VA 24011
Address of Attorney-in-Fact

Contract No.
County

C204837

Forsyth

Rev 5-17-11

CONTRACT PAYMENT BOND

CORPORATION

SIGNATURE OF CONTRACTOR (Principal)

CATON CONSTRUCTION GROUP INC

Full name of Corporation

P.O. BOX 4488, Charlottesville, VA 22905

Address as prequalified

By

Signature of ~~President, Vice President, Assistant Vice President~~

Select appropriate title

Diane E. Caton, Vice President

Print or type Signer's name

Affix Corporate Seal

Attest

Signature of Secretary, ~~Assistant Secretary~~

Select appropriate title

Dean T. Wenger, Secretary

Print or type Signer's name



Contract No. C204837
County Forsyth

Rev 5-17-11

Bond No. 4467794

CONTRACT PERFORMANCE BOND

Date of Performance Bond Execution: July 11, 2023
Name of Principal Contractor: Caton Construction Group, Inc.
Name of Surety: Markel Insurance Company
Name of Contracting Body: North Carolina Department of Transportation
Raleigh, North Carolina
Amount of Bond: \$23,925,288.63
Contract ID No.: C204837
County Name: Forsyth

KNOW ALL MEN BY THESE PRESENTS, That we, the PRINCIPAL CONTRACTOR (hereafter, PRINCIPAL) and SURETY above named, are held and firmly bound unto the above named Contracting Body, hereinafter called the Contracting Body, in the penal sum of the amount stated above for the payment of which sum well and truly to be made, we bind ourselves, our heirs, executors, administrators, and successors, jointly and severally, firmly by these presents.

THE CONDITION OF THIS OBLIGATION IS SUCH, that whereas the principal entered into a certain contract with the Contracting Body, numbered as shown above and hereto attached:

NOW THEREFORE, if the principal shall well and truly perform and fulfill all the undertakings, covenants, terms, conditions, and agreements of said contract during the original term of said contract and any extensions thereof that may be granted by the Contracting Body, with or without notice to the Surety, and during the life of any guaranty required under the contract, and shall also well and truly perform and fulfill all the undertakings, covenants, terms, conditions, and agreements of any and all duly authorized modifications of said contract that may hereafter be made, notice of which modifications to the surety being hereby waived, then this obligation to be void; otherwise to remain in full force and virtue.

IN WITNESS WHEREOF, the above-bound parties have executed this instrument under their several seals on the date indicated above, the name and corporate seal of each corporate party being hereto affixed and these presents duly signed by its undersigned representative, pursuant to authority of its governing body.

Contract No. C204837
County Forsyth

Rev 5-17-11

CONTRACT PERFORMANCE BOND

Markel Insurance Company

Print or type Surety Company Name

By **Theresa S. Stump, Attorney-In-Fact**

Print, stamp or type name of Attorney-in-Fact



Signature of Attorney-in-Fact



Signature of Witness

Deanna W. Sparks, Witness

Print or type Signer's name

10 Franklin Road, S.E., Suite 550, Roanoke, VA 24011

Address of Attorney-in-Fact

Contract No. C204837
County Forsyth

Rev 5-17-11

**CONTRACT PERFORMANCE BOND
CORPORATION**

SIGNATURE OF CONTRACTOR (Principal)

CATON CONSTRUCTION GROUP INC

Full name of Corporation

P.O. BOX 4488, Charlottesville, VA 22905

Address as prequalified

By

Signature of President, Vice President, Assistant Vice President
Select appropriate title

Diane E. Caton, Vice President

Print or type Signer's name

Affix Corporate Seal



Attest



Signature of Secretary, Assistant Secretary
Select appropriate title

Dean T. Wenger, Secretary

Print or type Signer's name

JOINT LIMITED POWER OF ATTORNEY

KNOW ALL MEN BY THESE PRESENTS: That SureTec Insurance Company, a Corporation duly organized and existing under the laws of the State of Texas and having its principal office in the County of Harris, Texas and Markel Insurance Company (the "Company"), a corporation duly organized and existing under the laws of the state of Illinois, and having its principal administrative office in Glen Allen, Virginia, does by these presents make, constitute and appoint:

James J. Roberts, III, Theresa S. Stump

Their true and lawful agent(s) and attorney(s)-in-fact, each in their separate capacity if more than one is named above, to make, execute, seal and deliver for and on their own behalf, individually as a surety or jointly, as co-sureties, and as their act and deed any and all bonds and other undertaking in suretyship provided, however, that the penal sum of any one such instrument executed hereunder shall not exceed the sum of:

Fifty Million and 00/100 Dollars (\$50,000,000.00)

This Power of Attorney is granted and is signed and sealed under and by the authority of the following Resolutions adopted by the Board of Directors of SureTec Insurance Company and Markel Insurance Company:

"RESOLVED, That the President, any Senior Vice President, Vice President, Assistant Vice President, Secretary, Assistant Secretary, Treasurer or Assistant Treasurer and each of them hereby is authorized to execute powers of attorney, and such authority can be executed by use of facsimile signature, which may be attested or acknowledged by any officer or attorney, of the company, qualifying the attorney or attorneys named in the given power of attorney, to execute in behalf of, and acknowledge as the act and deed of the SureTec Insurance Company and Markel Insurance Company, as the case may be, all bond undertakings and contracts of suretyship, and to affix the corporate seal thereto."

IN WITNESS WHEREOF, Markel Insurance Company and SureTec Insurance Company have caused their official seal to be hereunto affixed and these presents to be signed by their duly authorized officers on the 27th day of January, 2023.

SureTec Insurance Company

By: 
Michael C. Keimig, President

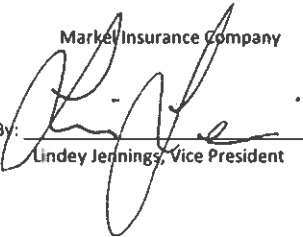

Markel Insurance Company

By: 
Lindsey Jennings, Vice President

State of Texas
County of Harris:

On this 27th day of January, 2023 A. D., before me, a Notary Public of the State of Texas, in and for the County of Harris, duly commissioned and qualified, came THE ABOVE OFFICERS OF THE COMPANIES, to me personally known to be the individuals and officers described in, who executed the preceding instrument, and they acknowledged the execution of same, and being by me duly sworn, disposed and said that they are the officers of the said companies aforesaid, and that the seals affixed to the proceeding instrument are the Corporate Seals of said Companies, and the said Corporate Seals and their signatures as officers were duly affixed and subscribed to the said instrument by the authority and direction of the said companies, and that Resolutions adopted by the Board of Directors of said Companies referred to in the preceding instrument is now in force.

IN TESTIMONY WHEREOF, I have hereunto set my hand, and affixed my Official Seal at the County of Harris, the day and year first above written.

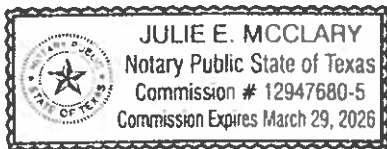

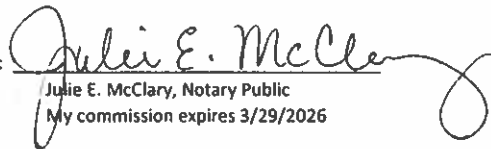
By: 
Julie E. McClary, Notary Public
My commission expires 3/29/2026

We, the undersigned Officers of SureTec Insurance Company and Markel Insurance Company do hereby certify that the original POWER OF ATTORNEY of which the foregoing is a full, true and correct copy is still in full force and effect and has not been revoked.

IN WITNESS WHEREOF, we have hereunto set our hands, and affixed the Seals of said Companies, on the 11th day of July, 2023.

SureTec Insurance Company

By: 
M. Brent Beatty, Assistant Secretary

Markel Insurance Company

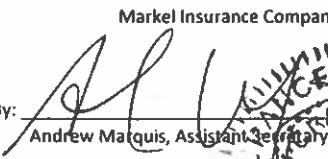
By: 
Andrew Marquis, Assistant Secretary

