



STATE OF NORTH CAROLINA  
DEPARTMENT OF TRANSPORTATION

ROY COOPER  
GOVERNOR

J.R. "JOEY" HOPKINS  
SECRETARY

November 14, 2024

**Addendum No. 1**

RE: Contract # C204942

WBS # 48662.3.1

STATE FUNDED

**New Hanover County (U-6202)**

SR-2048 (GORDON RD) FROM US-17 (MARKET ST) TO I-40.

**November 19, 2024 Letting**

To Whom It May Concern:

Reference is made to the proposal and plans furnished to you on this project.

The following revision has been made to the Roadway Plans.

Sheet No.	Revision
2D-1	General Note 5 revised. General Note 7 added.

Please void the above listed Sheet in your Plans and staple the revised Sheet thereto.

The following revisions have been made to the Signals Plans.

Sheet No.	Revision
Sig. 2.1, Sig. 3.1, Sig. 4.1, Sig. 5.1, Sig. 6.1, Sig. 7.1, Sig. 8.1, Sig. 12.1, Sig. 13.1, Sig. 14.1, Sig. 22.1, Sig. 23.1, Sig. 24.1	Equipment Information updated to reflect new pay items below.

Please void the above listed Sheets in your Plans and staple the revised Sheets thereto.

The following revisions have been made to the proposal.

<b>Page No.</b>	<b>Revision</b>
Proposal Cover	Note added that reads “Includes Addendum No. 1 Dated 11-14-2024”.
G-8	The Project Special Provision entitled <b>SPECIALTY ITEMS</b> has been revised.
UC-1	The Utilities Unit Project Special Provisions have been revised. Language following “ <b>Page 10-65, Sub-article 1034-2 Plastic Pipe, (A) PVC Gravity Flow Sewer Pipe, line 13: Remove the paragraph and replace with the following:</b> ” has been revised.
UC -12 thru UC-15	The Utilities Unit Project Special Provisions have been revised. Language following “ <b>Page 15-14, Sub-article 1525-2 Materials, line 22: Add the following paragraphs to the end of the section:</b> ” has been revised on pages UC-12 thru UC-13.
UC -16 thru UC-18	The Utilities Unit Project Special Provisions have been revised. Language following “ <b>Page 15-19, Sub-article 1550-2 Materials, line 19: Add the following paragraph to the end of the section:</b> ” has been revised on UC-16
TS-1 thru TS-70	The Signals Unit Project Special Provisions have been revised to reflect new pay items shown below. Section 3.5 Measurement and Payment added to “Controller with Cabinets”.

Please void the above listed existing Pages in your proposal and staple the revised Pages thereto.

On the item sheets the following pay item revisions have been made:

<b><u>Item</u></b>	<b><u>Description</u></b>	<b><u>Old Quantity</u></b>	<b><u>New Quantity</u></b>
0270-7696000000-N 1751	CONTROLLERS WITH CABINET (2070LX BASE MTD)	10 EA	DELETED
0291-7980000000-N SP	INSTALL DEPARTMENT SUPPLIED 2070 CONTROLLER	NEW ITEM	9 EACH
0292-7980000000-N SP	CABINET WITHOUT CONTROLLER (TYPE 170E, BASE MOUNTED)	NEW ITEM	9 EACH

The Contractor's bid must include these pay item revisions.

The electronic bidding file has been updated to reflect these revisions. Please download the Addendum File and follow the instructions for applying the addendum. Bid Express will not accept your bid unless the addendum has been applied.

The contract will be prepared accordingly.

Sincerely,

Signed by:  
  
52C46046381F443...

Ronald E. Davenport, Jr., PE  
State Contract Officer

RED/cms  
Attachments

cc: Mr. Wiley W. Jones III, PE  
Mr. Trevor Carroll, PE  
Mr. Ken Kennedy, PE  
Mr. Malcolm Bell

Mr. Forrest Dungan, PE  
Ms. Jaci Kincaid  
Mr. Jon Weathersbee, PE  
Project File (2)

STATE OF NORTH CAROLINA  
DEPARTMENT OF TRANSPORTATION  
RALEIGH, N.C.

PROPOSAL

**INCLUDES ADDENDUM No. 1 DATED 11-14-2024**

DATE AND TIME OF BID OPENING: **Nov 19, 2024 AT 02:00 PM**

CONTRACT ID        C204942  
WBS                    48662.3.1

FEDERAL-AID NO.    STATE FUNDED  
COUNTY             NEW HANOVER  
T.I.P NO.             U-6202  
MILES                 2.574  
ROUTE NO.            SR-2048  
LOCATION               SR-2048 (GORDON RD) FROM US-17 (MARKET ST) TO I-40.

TYPE OF WORK       GRADING, DRAINAGE, PAVING, SIGNALS, AND CULVERT.

**NOTICE:**

ALL BIDDERS SHALL COMPLY WITH ALL APPLICABLE LAWS REGULATING THE PRACTICE OF GENERAL CONTRACTING AS CONTAINED IN CHAPTER 87 OF THE GENERAL STATUTES OF NORTH CAROLINA WHICH REQUIRES THE BIDDER TO BE LICENSED BY THE N.C. LICENSING BOARD FOR CONTRACTORS WHEN BIDDING ON ANY NON-FEDERAL AID PROJECT WHERE THE BID IS \$30,000 OR MORE, EXCEPT FOR CERTAIN SPECIALTY WORK AS DETERMINED BY THE LICENSING BOARD. BIDDERS SHALL ALSO COMPLY WITH ALL OTHER APPLICABLE LAWS REGULATING THE PRACTICES OF ELECTRICAL, PLUMBING, HEATING AND AIR CONDITIONING AND REFRIGERATION CONTRACTING AS CONTAINED IN CHAPTER 87 OF THE GENERAL STATUTES OF NORTH CAROLINA. NOTWITHSTANDING THESE LIMITATIONS ON BIDDING, THE BIDDER WHO IS AWARDED ANY FEDERAL - AID FUNDED PROJECT SHALL COMPLY WITH CHAPTER 87 OF THE GENERAL STATUTES OF NORTH CAROLINA FOR LICENSING REQUIREMENTS WITHIN 60 CALENDAR DAYS OF BID OPENING.

**BIDS WILL BE RECEIVED AS SHOWN BELOW:**

**THIS IS A ROADWAY & CULVERT PROPOSAL**

**5% BID BOND OR BID DEPOSIT REQUIRED**

---

**SPECIALTY ITEMS:**

(7-1-95)(Rev. 1-16-24)

108-6

SP1 G37

Items listed below will be the specialty items for this contract (see Article 108-6 of the *Standard Specifications*).

<b>Line #</b>	<b>Description</b>
77-83	Guardrail
84-85	Fencing
89-105	Signing
125-131	Long-Life Pavement Markings
143	Permanent Pavement Markers
145-197	Utility Construction
198-229	Erosion Control
230-285, 291-292	Signals/ITS System

**FUEL PRICE ADJUSTMENT:**

(11-15-05)(Rev. 1-16-24)

109-8

SP1 G43

**Page 1-82, Article 109-8, FUEL PRICE ADJUSTMENTS**, add the following:

The base index price for DIESEL #2 FUEL is \$ **2.2387** per gallon. Where any of the following are included as pay items in the contract, they will be eligible for fuel price adjustment.

Project: U-6202

UC-1

County: NEW HANOVER

PROJECT SPECIAL PROVISIONS  
Utility Construction



2052 Energy Drive  
Apex, NC 27502  
Phone: 919.297.0220  
NC License: C-4647

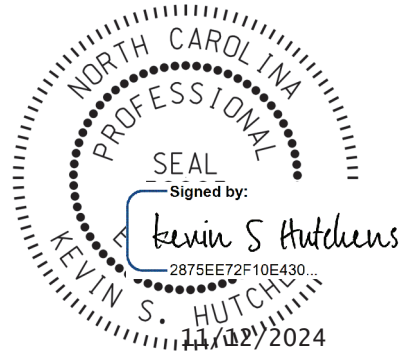

**DOCUMENT NOT CONSIDERED FINAL  
UNLESS ALL SIGNATURES COMPLETED**

Where brand names and model numbers are specified in these Special Provisions or in the plans, the cited examples are used only to denote the quality standard of product desired and do not restrict bidders to a specific brand, make, or manufacturer. They are provided to set forth the general style, type, character, and quality of the product desired. Equivalent products will be acceptable.

The utility owner is the Cape Fear Public Utility Authority. The contact person is David Dailey, and he can be reached by phone at 910-332-6626.

The provisions contained within these Utilities Construction Project Special Provisions modify the *Standard Specifications* only for materials used and work performed constructing water or sewer facilities owned by Cape Fear Public Utility Authority.

**SUBMITTALS AND RECORDS**  
**(9-5-23)**

Revise the 2024 *Standard Specifications* as follows:

**Page 10-65, Sub-article 1034-2 Plastic Pipe, (A) PVC Gravity Flow Sewer Pipe, line 13:**  
Remove the paragraph and replace with the following:

For pipe sizes 8" through 12", pipe shall be SRD-35 conforming to the requirements of ASTM D3034.

Couplings shall be mechanical joint ductile iron.

Project: U-6202

**UC-12**

County: NEW HANOVER

Use precast concrete manholes with monolithic bottoms which conform to ASTM C478, AASHTO M 199 and are as shown in the plans or in Roadway Standard Drawings. Joint surfaces between bases, risers and cones shall be manufactured to the joint surface design and tolerance requirements of ASTM C76. Use ASTM C443 gaskets or AASHTO M 198 flexible sealants for joints between precast manhole sections. Internal seals shall consist of Type S mortar grout. Use resilient connectors for piping conforming to ASTM C923.

**Page 15-14, Sub-article 1525-2 Materials, line 16:**

Edit the paragraph to read as follows:

Use manhole frames and covers made of cast iron conforming to ASTM A48 Class 35B, which are capable of withstanding a minimum H-20 type loading, have machined contact surfaces and are sized as shown. Standard covers shall have up to four 1" diameter vent holes. All covers shall have lifting bars in lieu of pickholes. Watertight covers are required on all manholes where the rim elevation is less than 1 foot above the 100-year flood. Use covers with "Sanitary Sewer" or "Water" cast in large letters as appropriate for the type of utility. Standard and watertight frames shall have a 24 inch clear opening.

**Page 15-14, Sub-article 1525-2 Materials, line 21:**

Edit the paragraph to read as follows:

Grout for sealing openings and joints in manholes shall be Type S mortar. No Preco or Hydraulic Cement shall be permitted.

**Page 15-14, Sub-article 1525-2 Materials, line 22:**

Add the following paragraphs to the end of the section:

Concrete shall conform to ASTM C478, ASTM C913 and as follows:

- a. Compressive strength: 4000 psi minimum at 28 days.
- b. Air Content: 4 percent minimum.
- c. Cementitious Materials: Minimum of 564 pounds per c.y.
- d. Coarse Aggregates: ASTM C33.
- e. Fine Aggregates: ASTM C33. Free from organic impurities.
- f. Chemical Admixtures: ASTM C494. Calcium Chloride or admixtures containing calcium shall not be used.
- g. Air Entraining Admixtures: ASTM C260.

Mortar shall conform to ASTM C270, Type S.

All structures shall be coated prior to testing. The exterior of all structures shall be coated with two coats of a bituminous coating system at a rate of 120 square feet per gallon prior to testing.

The interior of all structures shall be lined with Polycrete or RAVEN 405 which shall meet or exceed the performance specifications of:

Project: U-6202

# UC-13

County: NEW HANOVER

- Manufacture shall warrant material and workmanship for a minimum period of ten (10) years.
- Shall be high bond epoxy coating with broad chemical resistance.
- Shall provide a waterproof, corrosion resistant liner to prevent any deterioration of concrete surfaces from hydrogen sulfide and other corrosive gases/acids produced by wastewater.
- Can be used to rehabilitate and protect concrete, steel, fiberglass, or masonry surfaces.
- System shall restore structural integrity of brick/concrete structures.
- Shall use an approved quick setting cementitious material to bring substrate to profile.
- To ensure total unit responsibility, all material and installation shall be furnished by, and coordinated with, one supplier/ manufacturer.
- The resin based material shall be used to form the sprayed on/structure enhanced monolithic liner covering all interior surfaces to be protected and shall include the walls, ceiling, benches, inverts and pipe entries.
- Application of liner system shall be in strict accordance with manufacture’s recommendation.

### Liner System Minimum Physical/Material Properties

Flexural Strength	ASTM D790	13,000 psi
Comprehensive Strength	ASTM D695	18,000 psi
Tensile Strength	ASTM D638	7,600 psi
Hardness, Shore D	ASTM D2240	88
Adhesive Strength	Direct to Metal	>1,400 psi
Adhesive Strength	Direct to Concrete	Substrate Failure

Each manhole shall be equipped with an insert of high-density copolymer meeting the requirements of ASTM 124 for non-traffic areas and 304 stainless steel with a thickness of not less than 18-gauge for traffic areas, with gas relief valves matching manhole covers and rings. The gas relief valve shall be designed to release at a pressure of 0.5 to 1.5 psi and have a water leak down rate no greater than 5 gallons per 24 hours.

Vents in remote or outfall areas shall be constructed of aluminum or 316 stainless steel or better and shall extend a minimum of 2 feet above the 100-year flood elevation with integral non-corrosive insect screen. Vents in residential neighborhoods and commercial areas require special approval by the utility owner.

**Page 15-15, Sub-article 1525-3 Construction Methods, line 1:**

Edit the paragraph to read as follows:

Drop manholes shall be inside drop only with minimum 5' diameter for influent 8” or larger. Where sewer lines enter on a grade 30 inches or more above the invert of the discharge line, a drop manhole shall be constructed as directed by the Engineer. The drop or drops, shall be constructed in accordance with the Standard Detail, as shown on the plans, of 316 stainless steel or better excluding pipe with intermediate supports on 60-inch spacing as required.



Project: U-6202

**UC-14**

County: NEW HANOVER

**Page 15-15, Sub-article 1525-3 Construction Methods, line 1:**

Add the following to the end of the paragraph:

Steps shall be secured to the wall with a compression fit in tapered holes or cast in place. Steps shall not be vibrated or driven into freshly cast concrete or grouted in place.

**Page 15-15, Sub-article 1525-3 Construction Methods, line 6:**

Edit the paragraph to read as follows:

Construct invert channels to confine and direct the flow through sanitary sewer manholes. Use smooth finished invert channels that provide easy transition from inlet to outlet. Finish the benches or shelves to a non-slip texture and slope toward the invert channel. The invert channels shall be formed directly in the concrete of the manhole base with 3,000 psi concrete, 28 day strength. The invert channels shall be 3/4 the depth of the largest pipe.

**Page 15-15, Sub-article 1525-3 Construction Methods, line 15:**

Add the following paragraphs to the end of the section:

Joints between precast components shall be sealed between the tongue and the groove and additionally around the internal and external perimeter. Tongue and groove seals shall consist of a plastic or paper-backed butyl rubber rope no less than 14 feet long and having a cross-sectional area no less than the annular space times the height of the joint. Internal seals shall consist of Type S mortar grout. External seals shall consist of Type S mortar grout or plastic or paper-backed butyl rubber rope no less than 14 feet long and having a cross-sectional area no less than the annular space times the height of the joint.

Manholes 4-feet deep or less shall have an eccentric cone or a flat top. Manholes over 4-feet deep shall have an eccentric cone.

Manholes shall have a minimum inside diameter of 4 feet for sewer mains 12 inches diameter and smaller manholes shall be 5 feet inside diameter for sewer mains larger than 12 inches. Larger inside diameters may be required for larger pipe sizes, more than two pipes, or when entrance/exit angle requires. 5 foot diameter manholes shall have an 8 inch extended base. 4 foot diameter manholes shall have a 6 inch extended base. All extended bases shall have a minimum thickness of 6-inches.

Manholes shall be constructed of pre-cast concrete rings in accordance with the Drawings. The pre-cast concrete base shall be placed on a six inch (minimum) stone bedding foundation which shall extend up around the pipes to at least 3 inches above the top line of the pipes. The stone bedding shall be considered as incidental to the unit price bid for the installed manhole. All pre-cast manhole components shall be lifted and moved by use of suitable lifting slings and plugs that will not damage the pre-cast manhole lip.

Provide a minimum of six inches of separation between edge of manhole core holes and manhole barrel joints. Provide a minimum of six inches separation between edges of core holes. Coring

Project: U-6202

**UC-15**

County: NEW HANOVER

the manhole cone section is not allowed. All manhole main line and service piping shall be installed at a minimum of crown to crown of the largest diameter pipe.

All damage to pre-cast sections shall be thoroughly repaired in the presence of the Engineer. Repair and patching of minor breaks shall be done by chipping and scarifying the defective area before application of grout. Pre-cast sections shall be subject to rejection on account of failure to conform to any of the specification requirements. In addition, individual sections of manhole sections may be rejected because of fractures or cracks passing through the wall, except for a single end crack that does not exceed the depth of the joint; defects that indicate imperfect proportioning, mixing, and molding; surface defects indicating honey-combed or open texture; damaged or cracked end, where such damage would prevent making a satisfactory joint; and/or any continuous crack having a surface which width of 0.01 inches or more and extending for a length of 12 inches or more, regardless of position in the section wall.

All upstream pipes (including services) shall have sloped invert channel slides that provide smooth transitions to the downstream invert channel. Invert channel slides shall be the diameter of the entering pipe and be formed as a channel that is at least 3/4 pipe deep. Upstream pipes that enter at the shelf shall have their invert channel slides smoothly cast into the shelf with a sloping transition to the downstream pipe invert.

The floor of the manhole outside the channels, or slides, shall be smooth and shall slope toward the channels at 1 inch per foot.

Manhole castings shall be installed to grade using 24 inch inside diameter pre-cast concrete grade rings, or brick grouted in place, for a maximum adjustment of 8 inches. Manhole sections shall be used for greater adjustment, unless approved otherwise. Flat top manholes shall not be adjusted by more than one course of brick (4 inches).

For the bid item "Connect Proposed Sewer Lines to Existing Manhole", where new sewer lines are to be connected to existing manholes, holes of the proper size shall be cored at the proper location into the existing manholes. The bottom of the manhole shall be rechanneled to provide smooth flow through the manhole and shall match the bottom of the pipe. Other methods of coring shall be approved by utility owner. If the manhole cannot successfully cored due to its condition, a hole shall be cut into the existing manhole. The sewer pipe shall then be inserted, and the end of the pipe shall be flush with the inside of the manhole connection made smooth and water-tight with a Type "A" mortar.

**Page 15-16, Sub-article 1525-4 Measurement and Payment, line 11:**

Add the following to the end of the paragraph:

The work performed and materials furnished for "*Generic Utility Item: Adjust Existing Manhole to Grade*", will be measured and paid per Each. This price is a full compensation for all materials, including excavation and backfill, tools equipment, labor and incidentals as required to complete this work.

"*Generic Utility Item – Connect Existing Line to Proposed Manhole*", will be measured and paid per Each manhole a new connection is made to. Price shall include all means necessary for complete connection, including cutting the hole in the manhole, rechanneling and reshaping the bottom as necessary to provide

Project: U-6202

# UC-16

County: NEW HANOVER

smooth flow, grouting of the pipe and including and furnishing of all equipment, labor, materials, tools, power, testing and incidentals necessary to complete the work except the proposed sanitary sewer manhole.

*“Generic Utility Item – Connect Proposed Sewer Line to Existing Manhole”*, will be measured and paid *per Each* new connection of proposed sanitary sewer line to an existing sewer manhole. Price shall include all means necessary for complete connection, including cutting the hole in the manhole, rechanneling and reshaping the bottom as necessary to provide smooth flow, grouting of the pipe, watertight seal, testing and including and furnishing of all equipment, labor, materials, tools, power and incidentals necessary to complete the work except the proposed sanitary sewer line.

*“Generic Utility Item – Connect Proposed Force Main Line to Existing Manhole”*, will be measured per Each connection of proposed force main line to a Existing Sanitary Sewer Manhole. Price shall include all means necessary for complete connection, including cutting the hole in the manhole or tie-in precast hole, rechanneling and reshaping the bottom to provide smooth flow, grouting of the pipe, watertight seal, testing and including and furnishing of all equipment, labor, materials, tools, power and incidentals necessary to complete the work except the proposed sanitary force main sewer line.

**Page 15-16, Sub-article 1525-4 Measurement and Payment, line 12:**

Add the following to the end of paragraph:

<b>Pay Item</b>	<b>Pay Unit</b>
“Generic Utility Item - Adjust Existing Manhole to Grade.”	per Each.
“Generic Utility Item – Connect Existing Line to Proposed Manhole”,	per Each.
“Generic Utility Item – Connect Proposed Sewer Line to Existing Manhole”,	per Each.
“Generic Utility Item – Connect Proposed Force Main Line to Existing Manhole”,	per Each.

**Page 15-19, Sub-article 1550-2 Materials, line 19:**

Add the following paragraph to the end of the section:

Material shall be fusible PVC C900 DR-18 may be considered for mains 4” and larger when hydraulic or availability restrictions apply, only by utility owner approval. Compression type connections are not acceptable. Pipe shall be heat fusion welded. Mechanical fittings shall be authorized by the manufacturer for use on polyethylene pipe. Pipe shall meet and exceed all performance specifications in the current version of AWWA C900 and pipe shall be (Green) for Sanitary Sewers and (Blue) for Water Mains.

**Page 15-20, Sub-article 1550-3 Construction Methods, (E) Pre-Construction Meeting, line 33:**

Add the following paragraph to the end of the section:

The Contractor must submit to the Engineer shop drawings on pipe materials, manufacturer’s installation manual, erosion control plan and work plan detailing the procedure and schedule to be used to execute the project. The work plan should include a description of all equipment to be used, down-hole tools, a list of personnel and their qualifications and experience (including

Project: U-6202

**UC-17**

County: NEW HANOVER

back-up personnel in the event that an individual is unavailable), list of subcontractors, a schedule of work activity, a safety plan (including MSDS of any potentially hazardous substances to be used), traffic control plan (if applicable), an environmental protection plan and contingency plans for possible problems. Work plan should be comprehensive, realistic, and based on actual working conditions for this particular project. Plan should document the thoughtful planning required to successfully complete the project.

**Page 15-22, Sub-article 1550-4 Trenchless Methods, (B) Directional Drilling, line 28:**

Add the following sentence to the end of the section:

Two tracer wires shall be installed and taped to the drill host pipe at 10' intervals.

**The following sections from CFPUA's Technical Specifications shall be incorporated into these Special Provisions:**

**01 40 00 Quality Requirements**

Contractor shall provide CFPUA with a minimum of two business days' notice (by email) prior to the following activities and/or inspections:

1. When construction begins
2. Operating any CFPUA valve (including tapping, tie-in, fire line or service valves)
3. If the contractor pulls off the site for more than two (2) weeks
4. Installing a sewer main out of a tie-in to an existing manhole
5. Cutting in a new manhole on an existing line
6. Coring an existing manhole
7. Tapping an existing sewer main, water main or force main.
8. Any bores and threading carrier pipes
9. All camera work, testing, chlorination, and water sampling
10. Setting up or operating a sewer by-pass
11. Concrete placement
12. Excavating, trenching, dewatering, and backfilling
13. Disinfection of water pipelines, facilities, and appurtenances
14. When material is delivered to the job site

**01 51 00 Temporary Sewer Bypass Pumping**

Provide the following submittals:

1. Temporary Bypass Pumping Plans designated by type and location.
  - a. The Engineering Committee of the NC Board of Examiners for Engineers and Surveyors (NCBELS) ruled that providing design plans and calculations for temporary bypass pump systems is the practice of engineering and requires licensure with NCBELS per G.S. 89C-23 and -24, meaning the design work shall be done by Professional Engineers and companies licensed to practice engineering in North Carolina.

Project: U-6202

**UC-18**

County: NEW HANOVER

2. System test results and operation logs.
3. Obtain Engineer and ORC approval of submittals prior to mobilization of equipment included in the plans.

**33 05 09.33 Thrust Restraint for Utility Piping**

Unless otherwise indicated, provide pressure pipelines (water and force mains) with restrained joints and/or blocking at any change in direction including hydrant assemblies, bends, tees, reducers, blow-offs, dead-end mains, cut-in tees, tapping sleeves, etc.

U-6202

TS-1

New Hanover County

Signals and Intelligent Transportation Systems  
Project Special Provisions  
(Version 24.0)

Prepared By: NRS  
8-Nov-24

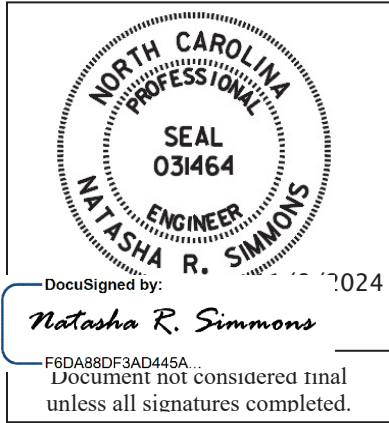

Contents

1.1. MATERIALS – JUNCTION BOXES (1098-6 (D)).....4

2. SIGNAL HEADS.....4

2.1. MATERIALS .....4

A. General: .....4

B. Vehicle Signal Heads:.....6

C. Pedestrian Signal Heads: .....8

3. CONTROLLERS WITH CABINETS .....10

3.1. MATERIALS – DEPARTMENT FURNISHED TYPE 2070 CONTROLLERS .....10

3.2. MATERIALS – GENERAL CABINETS .....10

3.3. MATERIALS – TYPE 170E CABINETS .....11

A. Type 170 E Cabinets General: .....11

B. Type 170 E Cabinet Electrical Requirements: .....11

C. Type 170 E Cabinet Physical Requirements: .....17

D. Model 2018 Enhanced Conflict Monitor: .....18

3.4. MATERIALS – TYPE 170 DETECTOR SENSOR UNITS .....29

3.5. MEASUREMENT AND PAYMENT .....29

4. MICROWAVE VEHICLE DETECTION SYSTEM - MULTIPLE DETECTION ZONES.....30

4.1. DESCRIPTION .....30

4.2. MATERIALS .....30

4.3. CONSTRUCTION METHODS .....31

4.4. MEASUREMENT AND PAYMENT .....31

5. METAL POLE SUPPORTS .....31

5.1. METAL POLES .....31

A. General: .....31

B. Materials: .....33

C. Design:.....35

D. Strain Poles: .....37

E. Mast Arm Poles: .....37

5.2. DRILLED PIER FOUNDATIONS FOR METAL POLES.....39

A. Description: .....39

B. Soil Test and Foundation Determination: .....40

C. Drilled Pier Construction: .....42

5.3. METAL POLE REMOVALS .....42

A. Description: .....42

B. Construction Methods:.....42

5.4. POLE NUMBERING SYSTEM .....43

5.5. MEASUREMENT AND PAYMENT .....43

6. ETHERNET EDGE SWITCH.....44

- 6.1. DESCRIPTION ..... 44
  - A. Ethernet Edge Switch: ..... 44
  - B. Network Management: ..... 44
- 6.2. MATERIALS ..... 44
  - A. General: ..... 44
  - B. Compatibility Acceptance..... 44
  - C. Standards: ..... 44
  - D. Functional: ..... 45
  - E. Physical Features: ..... 46
  - F. Management Capabilities: ..... 46
  - G. Electrical Specifications: ..... 47
  - H. Environmental Specifications: ..... 48
  - I. Ethernet Patch Cable: ..... 48
- 6.3. CONSTRUCTION METHODS ..... 49
  - A. General: ..... 49
  - B. Edge Switch: ..... 49
- 6.4. MEASUREMENT AND PAYMENT ..... 49
- 7. DIGITAL CCTV CAMERA ASSEMBLY ..... 49**
  - 7.1. DESCRIPTION ..... 49
  - 7.2. MATERIALS ..... 49
    - A. General..... 49
    - B. Camera and Lens ..... 50
    - C. Camera Housing ..... 51
    - D. Pan and Tilt Unit..... 51
    - E. Video Ethernet Encoder..... 52
    - F. Control Receiver/Driver ..... 52
    - G. Electrical..... 52
    - H. CCTV Camera Attachment to Pole..... 53
    - I. Riser..... 53
    - J. Data line Surge Suppression ..... 53
    - K. POE Injector ..... 53
  - 7.3. CONSTRUCTION METHODS ..... 54
    - A. General..... 54
    - B. Electrical and Mechanical Requirements..... 54
    - C. General Test Procedure..... 54
    - A. Compatibility Tests..... 55
    - B. Operational Field Test (On-Site Commissioning) ..... 55
    - C. Local Field Testing ..... 56
    - D. Central Operations Testing ..... 56
  - 7.4. MEASUREMENT AND PAYMENT ..... 57
- 8. CCTV FIELD EQUIPMENT CABINET..... 57**
  - 8.1. DESCRIPTION ..... 57
  - 8.2. MATERIALS ..... 57
    - A. CCTV Cabinet ..... 57
    - B. Shelf Drawer..... 58
    - C. Cabinet Light ..... 58
    - D. Surge Protection for System Equipment..... 58
  - 8.3. CONSTRUCTION METHODS ..... 60
    - A. General..... 60
  - 8.4. MEASUREMENT AND PAYMENT ..... 60
- 9. CCTV WOOD POLE ..... 61**
  - 9.1. DESCRIPTION ..... 61
  - 9.2. MATERIALS ..... 61
  - 9.3. CCTV WOOD POLE ..... 61

9.4. CONSTRUCTION METHODS ..... 61

9.5. MEASUREMENT AND PAYMENT ..... 61

**10. AIR TERMINAL & LIGHTNING PROTECTION SYSTEM..... 62**

10.1. DESCRIPTION ..... 62

10.2. MATERIALS ..... 62

    A. General..... 62

    B. Wood Pole ..... 62

    C. Copper Lightning Conductor and Ground Rods ..... 62

10.3. CONSTRUCTION METHODS ..... 63

    A. Wood Pole ..... 63

    B. Copper Lightning Conductor and Ground Rods ..... 63

10.4. MEASUREMENT AND PAYMENT ..... 63

**11. DROP CABLE ASSEMBLY ..... 64**

11.1. DESCRIPTION ..... 64

11.2. MATERIALS ..... 64

11.3. CONSTRUCTION METHODS ..... 64

11.4. MEASUREMENT AND PAYMENT ..... 65

**12. ELECTRICAL SERVICE FOR ITS DEVICES ..... 66**

12.1. DESCRIPTION ..... 66

12.2. MATERIAL ..... 66

    A. Meter Base/Disconnect Combination Panel ..... 66

    B. Equipment Cabinet Disconnect..... 67

    E. 3-Wire Copper Feeder Conductors ..... 68

    F. Grounding System ..... 68

12.3. CONSTRUCTION METHODS ..... 68

12.4. MEASUREMENT AND PAYMENT ..... 69



**1. 2024 STANDARD SPECIFICATIONS FOR ROADS & STRUCTURES**

*The 2024 Standard Specifications are revised as follows:*

**1.1. MATERIALS – Junction Boxes (1098-6 (D))**

Page 10-220, add section after line 16 to read:

**(D) Special Oversized Heavy Duty Junction Boxes**

Provide special oversized heavy duty junction boxes and covers with minimum inside dimensions of 36” (l) x 24” (w) x 24” (d).

**2. SIGNAL HEADS**

**2.1. MATERIALS**

**A. General:**

Fabricate vehicle signal head housings and end caps from die-cast aluminum. Fabricate 12-inch and 16-inch pedestrian signal head housings and end caps from die-cast aluminum. Provide visor mounting screws, door latches, and hinge pins fabricated from stainless steel. Provide interior screws, fasteners, and metal parts fabricated from stainless steel.

Fabricate tunnel and traditional visors from sheet aluminum.

Paint all surfaces inside and outside of signal housings and doors. Paint outside surfaces of tunnel and traditional visors, wire outlet bodies, wire entrance fitting brackets and end caps when supplied as components of messenger cable mounting assemblies, pole and pedestal mounting assemblies, and pedestrian pushbutton housings. Have electrostatically-applied, fused-polyester paint in highway yellow (Federal Standard 595C, Color Chip Number 13538) a minimum of 2.5 to 3.5 mils thick. Do not apply paint to the latching hardware, rigid vehicle signal head mounting brackets for mast-arm attachments, messenger cable hanger components or balance adjuster components.

Have the interior surfaces of tunnel and traditional visors painted an alkyd urea black synthetic baking enamel with a minimum gloss reflectance and meeting the requirements of MIL-E-10169, “Enamel Heat Resisting, Instrument Black.”

Where required, provide polycarbonate signal heads and visors that comply with the provisions pertaining to the aluminum signal heads listed on the QPL with the following exceptions:

Fabricate signal head housings, end caps, and visors from virgin polycarbonate material. Provide UV stabilized polycarbonate plastic with a minimum thickness of 0.1 ± 0.01 inches that is highway yellow (Federal Standard 595C, Color Chip 13538). Ensure the color is incorporated into the plastic material before molding the signal head housings and end caps. Ensure the plastic formulation provides the following physical properties in the assembly (tests may be performed on separately molded specimens):

Test	Required	Method
Specific Gravity	1.17 minimum	ASTM D 792
Flammability	Self-extinguishing	ASTM D 635
Tensile Strength, yield, PSI	8500 minimum	ASTM D 638
Izod impact strength, ft-lb/in [notched, 1/8 inch]	12 minimum	ASTM D 256

For pole mounting, provide side of pole mounting assemblies with framework and all other hardware necessary to make complete, watertight connections of the signal heads to the poles and pedestals. Fabricate the mounting assemblies and frames from aluminum with all necessary hardware, screws, washers, etc. to be stainless steel. Provide mounting fittings that match the positive locking device on the signal head with the serrations integrally cast into the brackets. Provide upper and lower pole plates that have a 1 ¼-inch vertical conduit entrance hubs with the hubs capped on the lower plate and 1 ½-inch horizontal hubs. Ensure that the assemblies provide rigid attachments to poles and pedestals so as to allow no twisting or swaying of the signal heads. Ensure that all raceways are free of sharp edges and protrusions, and can accommodate a minimum of ten Number 14 AWG conductors.

For pedestal mounting, provide a post-top slipfitter mounting assembly that matches the positive locking device on the signal head with serrations integrally cast into the slipfitter. Provide stainless steel hardware, screws, washers, etc. Provide a minimum of six 3/8 X 3/4-inch long square head bolts for attachment to pedestal. Provide a center post for multi-way slipfitters.

For light emitting diode (LED) traffic signal modules, provide the following requirements for inclusion on the Department's Qualified Products List for traffic signal equipment.

1. Sample submittal,
2. Third-party independent laboratory testing results for each submitted module with evidence of testing and conformance with all of the Design Qualification Testing specified in section 6.4 of each of the following Institute of Transportation Engineers (ITE) specifications:
  - Vehicle Traffic Control Signal Heads – Light Emitting Diode (LED) Circular Signal Supplement
  - Vehicle Traffic Control Signal Heads – Light Emitting Diode (LED) Vehicle Arrow Traffic Signal Supplement
  - Pedestrian Traffic Control Signal Indications –Light Emitting Diode (LED) Signal Modules.

(Note: The Department currently recognizes two approved independent testing laboratories. They are Intertek ETL Semko and Light Metrics, Incorporated with Garwood Laboratories. Independent laboratory tests from other laboratories may be considered as part of the QPL submittal at the discretion of the Department,

3. Evidence of conformance with the requirements of these specifications,
4. A manufacturer's warranty statement in accordance with the required warranty, and
5. Submittal of manufacturer's design and production documentation for the model, including but not limited to, electrical schematics, electronic component values, proprietary part numbers, bill of materials, and production electrical and photometric test parameters.
6. Evidence of approval of the product to bear the Intertek ETL Verified product label for LED traffic signal modules.

Ensure LED traffic signal modules meet the performance requirements for the minimum period of 15 years, provide a written warranty against defects in materials and workmanship for the modules for a period of 15 years after installation of the modules. During the warranty period, the manufacturer must provide new replacement modules within 45 days of receipt of modules that have failed at no cost to the State. Repaired or refurbished modules may not be used to fulfill the manufacturer's warranty obligations. Provide manufacturer's warranty documentation to the Department during evaluation of product for inclusion on Qualified Products List (QPL).

**B. Vehicle Signal Heads:**

Comply with the ITE standard "Vehicle Traffic Control Signal Heads". Provide housings with provisions for attaching backplates.

Provide visors that are 10 inches in length for 12-inch vehicle signal heads.

Provide a termination block with one empty terminal for field wiring for each indication plus one empty terminal for the neutral conductor. Have all signal sections wired to the termination block. Provide barriers between the terminals that have terminal screws with a minimum Number 8 thread size and that will accommodate and secure spade lugs sized for a Number 10 terminal screw.

Mount termination blocks in the yellow signal head sections on all in-line vehicle signal heads. Mount the termination block in the red section on five-section vehicle signal heads.

Furnish vehicle signal head interconnecting brackets. Provide one-piece aluminum brackets less than 4.5 inches in height and with no threaded pipe connections. Provide hand holes on the bottom of the brackets to aid in installing wires to the signal heads. Lower brackets that carry no wires and are used only for connecting the bottom signal sections together may be flat in construction.

For messenger cable mounting, provide messenger cable hangers, wire outlet bodies, balance adjusters, bottom caps, wire entrance fitting brackets, and all other hardware necessary to make complete, watertight connections of the vehicle signal heads to the messenger cable. Fabricate messenger cable hanger components, wire outlet bodies and balance adjuster components from stainless steel or malleable iron galvanized in accordance with ASTM A153 (Class A) or ASTM A123. Provide serrated rings made of aluminum. Provide messenger cable hangers with U-bolt clamps. Fabricate washers, screws, hex-head bolts and associated nuts, clevis pins, cotter pins, U-bolt clamps and nuts from stainless steel.

For mast-arm mounting, provide rigid vehicle signal head mounting brackets and all other hardware necessary to make complete, watertight connections of the vehicle signal heads to the mast arms and to provide a means for vertically adjusting the vehicle signal heads to proper alignment. Fabricate the mounting assemblies from aluminum, and provide serrated rings made of aluminum. Provide stainless steel cable attachment assemblies to secure the brackets to the mast arms. Ensure all fastening hardware and fasteners are fabricated from stainless steel.

Provide LED vehicular traffic signal modules (hereafter referred to as modules) that consist of an assembly that uses LEDs as the light source in lieu of an incandescent lamp for use in traffic signal sections. Use LEDs that are aluminum indium gallium phosphorus (AlInGaP) technology for red and yellow indications and indium gallium nitride (InGaN) for green indications. Install the ultra bright type LEDs that are rated for 100,000 hours of continuous operation from -40°F to +165°F. Design modules to have a minimum useful life of 15 years and to meet all parameters of this specification during this period of useful life.

For the modules, provide spade terminals crimped to the lead wires and sized for a #10 screw connection to the existing terminal block in a standard signal head. Do not provide other types of crimped terminals with a spade adapter.

Ensure the power supply is integral to the module assembly. On the back of the module, permanently mark the date of manufacture (month & year) or some other method of identifying date of manufacture.

Tint the red, yellow and green lenses to correspond with the wavelength (chromaticity) of the LED. Transparent tinting films are unacceptable. Provide a lens that is integral to the unit with a smooth outer surface.

**1. LED Circular Signal Modules:**

Provide modules in the following configurations: 12-inch circular sections, and 8-inch circular sections. All makes and models of LED modules purchased for use on the State Highway System shall appear on the current NCDOT Traffic Signal Qualified Products List (QPL).

Provide the manufacturer’s model number and the product number (assigned by the Department) for each module that appears on the 2024 or most recent Qualified Products List. In addition, provide manufacturer’s certification in accordance with Article 106-3 of the *Standard Specifications*, that each module meets or exceeds the ITE “Vehicle Traffic Control Signal Heads – Light Emitting Diode (LED) Circular Signal Supplement” dated June 27, 2005 (hereafter referred to as VTCSH Circular Supplement) and other requirements stated in this specification.

Provide modules that meet the following requirements when tested under the procedures outlined in the VTCSH Circular Supplement:

Module Type	Max. Wattage at 165° F	Nominal Wattage at 77° F
12-inch red circular	17	11
12-inch green circular	15	15

For yellow circular signal modules, provide modules tested under the procedures outlined in the VTCSH Circular Supplement to insure power required at 77° F is 22 Watts or less for the 12-inch circular module.

Note: Use a wattmeter having an accuracy of ±1% to measure the nominal wattage and maximum wattage of a circular traffic signal module. Power may also be derived from voltage, current and power factor measurements.

**2. LED Arrow Signal Modules:**

Provide 12-inch omnidirectional arrow signal modules. All makes and models of LED modules purchased for use on the State Highway System shall appear on the current NCDOT Traffic Signal Qualified Products List (QPL).

Provide the manufacturer’s model number and the product number (assigned by the Department) for each module that appears on the 2024 or most recent Qualified Products List. In addition, provide manufacturer’s certification in accordance with Article 106-3 of the *Standard Specifications*, that each module meets or exceeds the requirements for 12-inch omnidirectional modules specified in the ITE “Vehicle Traffic Control Signal Heads – Light Emitting Diode (LED) Vehicle Arrow Traffic Signal Supplement” dated July 1, 2007 (hereafter referred to as VTCSH Arrow Supplement) and other requirements stated in this specification.

Provide modules that meet the following requirements when tested under the procedures outlined in the VTCSH Arrow Supplement:

Module Type	Max. Wattage at 165° F	Nominal Wattage at 77° F
12-inch red arrow	12	9
12-inch green arrow	11	11

For yellow arrow signal modules, provide modules tested under the procedures outlined in the VTCSH Arrow Supplement to ensure power required at 77° F is 12 Watts or less.

Note: Use a wattmeter having an accuracy of ±1% to measure the nominal wattage and maximum wattage of an arrow traffic signal module. Power may also be derived from voltage, current and power factor measurements.

**3. LED U-Turn Arrow Signal Modules:**

Provide modules in the following configurations: 12-inch left u-turn arrow signal modules and 12-inch right u-turn arrow signal modules.

Modules are not required to be listed on the ITS and Signals Qualified Products List. Provide manufacturer’s certification in accordance with Article 106-3 of the *Standard Specifications*, that each module meets or exceeds the ITE “Vehicle Traffic Control Signal Heads – Light Emitting Diode (LED) Circular Signal Supplement” dated June 27, 2005 (hereafter referred to as VTCSH Circular Supplement) and other requirements stated in this specification.

Provide modules that have minimum maintained luminous intensity values that are not less than 16% of the values calculated using the method described in section 4.1 of the VTCSH Circular Supplement.

Provide modules that meet the following requirements when tested under the procedures outlined in the VTCSH Circular Supplement:

Module Type	Max. Wattage at 165° F	Nominal Wattage at 77° F
12-inch red u-turn arrow	17	11
12-inch green u-turn arrow	15	15

For yellow u-turn arrow signal modules, provide modules tested under the procedures outlined in the VTCSH Circular Supplement to ensure power required at 77° F is 22 Watts or less.

Note: Use a wattmeter having an accuracy of ±1% to measure the nominal wattage and maximum wattage of a circular traffic signal module. Power may also be derived from voltage, current and power factor measurements.

**C. Pedestrian Signal Heads:**

Provide pedestrian signal heads with international symbols that meet the MUTCD. Do not provide letter indications.

Comply with the ITE standard for “Pedestrian Traffic Control Signal Indications” and the following sections of the ITE standard for “Vehicle Traffic Control Signal Heads” in effect on the date of advertisement:

- Section 3.00 - “Physical and Mechanical Requirements”
- Section 4.01 - “Housing, Door, and Visor: General”
- Section 4.04 - “Housing, Door, and Visor: Materials and Fabrication”
- Section 7.00 - “Exterior Finish”

Provide a double-row termination block with three empty terminals and number 10 screws for field wiring. Provide barriers between the terminals that accommodate a spade lug sized for number 10 terminal screws. Mount the termination block in the hand section. Wire all signal sections to the terminal block.

Where required by the plans, provide 16-inch pedestrian signal heads with traditional three-sided, rectangular visors, 6 inches long.

Provide 2-inch diameter pedestrian push-buttons with weather-tight housings fabricated from die-cast aluminum and threading in compliance with the NEC for rigid metal conduit. Provide a weep hole in the housing bottom and ensure that the unit is vandal resistant.

Provide push-button housings that are suitable for mounting on flat or curved surfaces and that will accept 1/2-inch conduit installed in the top. Provide units that have a heavy duty push-button



assembly with a sturdy, momentary, normally-open switch. Have contacts that are electrically insulated from the housing and push-button. Ensure that the push-buttons are rated for a minimum of 5 mA at 24 volts DC and 250 mA at 12 volts AC.

Provide standard R10-3 signs with mounting hardware that comply with the MUTCD in effect on the date of advertisement. Provide R10-3E signs for countdown pedestrian heads and R10-3B for non-countdown pedestrian heads.

Design the LED pedestrian traffic signal modules (hereafter referred to as modules) for installation into standard pedestrian traffic signal sections that do not contain the incandescent signal section reflector, lens, eggcrate visor, gasket, or socket. Provide modules that consist of an assembly that uses LEDs as the light source in lieu of an incandescent lamp. Use LEDs that are of the latest aluminum indium gallium phosphorus (AlInGaP) technology for the Portland Orange hand and countdown displays. Use LEDs that are of the latest indium gallium nitride (InGaN) technology for the Lunar White walking man displays. Install the ultra-bright type LEDs that are rated for 100,000 hours of continuous operation from -40°F to +165°F. Design modules to have a minimum useful life of 60 months and to meet all parameters of this specification during this period of useful life.

Design all modules to operate using a standard 3 - wire field installation. Provide spade terminals crimped to the lead wires and sized for a #10 screw connection to the existing terminal block in a standard pedestrian signal housing. Do not provide other types of crimped terminals with a spade adapter.

Ensure the power supply is integral to the module assembly. On the back of the module, permanently mark the date of manufacture (month & year) or some other method of identifying date of manufacture.

Provide modules in the following configuration: 16-inch displays which have the solid hand/walking man overlay on the left and the countdown on the right, and 12-inch displays which have the solid hand/walking man module as an overlay. All makes and models of LED modules purchased for use on the State Highway System shall appear on the current NCDOT Traffic Signal Qualified Products List (QPL).

Provide the manufacturer’s model number and the product number (assigned by the Department) for each module that appears on the 2024 or most recent Qualified Products List. In addition, provide manufacturer’s certification in accordance with Article 106-3 of the *Standard Specifications*, that each module meets or exceeds the ITE “Pedestrian Traffic Control Signal Indicators - Light Emitting Diode (LED) Signal Modules” dated August 04, 2010 (hereafter referred to as PTCSI Pedestrian Standard) and other requirements stated in this specification.

Provide modules that meet the following requirements when tested under the procedures outlined in the PTCSI Pedestrian Standard:

Module Type	Max. Wattage at 165° F	Nominal Wattage at 77° F
Hand Indication	16	13
Walking Man Indication	12	9
Countdown Indication	16	13

Note: Use a wattmeter having an accuracy of ±1% to measure the nominal wattage and maximum wattage of a circular traffic signal module. Power may also be derived from voltage, current and power factor measurements.

Provide module lens that is hard coated or otherwise made to comply with the material exposure and weathering effects requirements of the Society of Automotive Engineers (SAE) J576. Ensure all

exposed components of the module are suitable for prolonged exposure to the environment, without appreciable degradation that would interfere with function or appearance.

Ensure the countdown display continuously monitors the traffic controller to automatically learn the pedestrian phase time and update for subsequent changes to the pedestrian phase time.

Ensure the countdown display begins normal operation upon the completion of the preemption sequence and no more than one pedestrian clearance cycle.

**3. CONTROLLERS WITH CABINETS**

**3.1. MATERIALS – DEPARTMENT FURNISHED TYPE 2070 CONTROLLERS**

Install 2070 controller furnished by the Department in a contractor supplied 170 cabinet that meets the material requirements of this Project Special Provision.

The Department will provide controller at the beginning of the burning-in period. Contractor shall give 5 working days notice before needing the controller.

**3.2. MATERIALS – GENERAL CABINETS**

Provide a moisture resistant coating on all circuit boards.

Provide one 20 mm diameter radial lead UL-recognized metal oxide varistor (MOV) between each load switch field terminal and equipment ground. Electrical performance is outlined below.

<b>PROPERTIES OF MOV SURGE PROTECTOR</b>	
Maximum Continuous Applied Voltage at 185° F	150 VAC (RMS) 200 VDC
Maximum Peak 8x20µs Current at 185° F	6500 A
Maximum Energy Rating at 185° F	80 J
Voltage Range 1 mA DC Test at 77° F	212-268 V
Max. Clamping Voltage 8x20µs, 100A at 77° F	395 V
Typical Capacitance (1 MHz) at 77° F	1600 pF

Provide a power line surge protector that is a two-stage device that will allow connection of the radio frequency interference filter between the stages of the device. Ensure that a maximum continuous current is at least 10A at 120V. Ensure that the device can withstand a minimum of 20 peak surge current occurrences at 20,000A for an 8x20 microsecond waveform. Provide a maximum clamp voltage of 395V at 20,000A with a nominal series inductance of 200µh. Ensure that the voltage does not exceed 395V. Provide devices that comply with the following:

Frequency (Hz)	Minimum Insertion Loss (dB)
60	0
10,000	30
50,000	55
100,000	50
500,000	50
2,000,000	60
5,000,000	40
10,000,000	20
20,000,000	25

### 3.3. MATERIALS – TYPE 170E CABINETS

#### A. Type 170 E Cabinets General:

Conform to the city of Los Angeles' Specification No. 54-053-08, *Traffic Signal Cabinet Assembly Specification* (dated July 2008), except as required herein.

Furnish model 332 base mounted cabinets configured for 8 vehicle phases, 4 pedestrian phases, and 6 overlaps. When overlaps are required, provide auxiliary output files for the overlaps. Do not reassign load switches to accommodate overlaps unless shown on electrical details.

Provide model 200 load switches, model 222 loop detector sensors, model 252 AC isolators, and model 242 DC isolators according to the electrical details. As a minimum, provide one (1) model 2018 conflict monitor, one (1) model 206L power supply unit, two (2) model 204 flashers, one (1) DC isolator (located in slot I14), and four (4) model 430 flash transfer relays (provide seven (7) model 430 flash transfer relays if auxiliary output file is installed) with each cabinet.

#### B. Type 170 E Cabinet Electrical Requirements:

Provide a cabinet assembly designed to ensure that upon leaving any cabinet switch or conflict monitor initiated flashing operation, the controller starts up in the programmed start up phases and start up interval.

Furnish two sets of non-fading cabinet wiring diagrams and schematics in a paper envelope or container and placed in the cabinet drawer.

All AC+ power is subject to radio frequency signal suppression.

Provide surge suppression in the cabinet for each type of cabinet device. Provide surge protection for the full capacity of the cabinet input file. Provide surge suppression devices that operate properly over a temperature range of -40° F to +185° F. Ensure the surge suppression devices provide both common and differential modes of protection.

Provide a pluggable power line surge protector that is installed on the back of the PDA (power distribution assembly) chassis to filter and absorb power line noise and switching transients. Ensure the device incorporates LEDs for failure indication and provides a dry relay contact closure for the purpose of remote sensing. Ensure the device meets the following specifications:



**U-6202**

**TS-12**

**New Hanover County**

Peak Surge Current (Single pulse, 8x20µs).....	20,000A
Occurrences (8x20µs waveform).....	10 minimum @ 20,000A
Maximum Clamp Voltage.....	395VAC
Operating Current.....	15 amps
Response Time.....	< 5 nanoseconds

Provide a loop surge suppressor for each set of loop terminals in the cabinet. Ensure the device meets the following specifications:

Peak Surge Current (6 times, 8x20µs)	
(Differential Mode).....	400A
(Common Mode).....	1,000A
Occurrences (8x20µs waveform).....	500 min @ 200A
Maximum Clamp Voltage	
(Differential Mode @400A).....	35V
(Common Mode @1,000A).....	35V
Response Time.....	< 5 nanoseconds
Maximum Capacitance.....	35 pF

Provide a data communications surge suppressor for each communications line entering or leaving the cabinet. Ensure the device meets the following specifications:

Peak Surge Current (Single pulse, 8x20µs).....	10,000A
Occurrences (8x20µs waveform).....	100 min @ 2,000A
Maximum Clamp Voltage.....	Rated for equipment protected
Response Time.....	< 1 nanosecond
Maximum Capacitance.....	1,500 pF
Maximum Series Resistance.....	15Ω

Provide a DC signal surge suppressor for each DC input channel in the cabinet. Ensure the device meets the following specifications:

Peak Surge Current (Single pulse, 8x20µs).....	10,000A
Occurrences (8x20µs waveform).....	100 @ 2,000A
Maximum Clamp Voltage.....	30V
Response Time.....	< 1 nanosecond

**U-6202**

**TS-13**

**New Hanover County**

Provide a 120 VAC signal surge suppressor for each AC+ interconnect signal input. Ensure the device meets the following specifications:

- Peak Surge Current (Single pulse, 8x20µs).....20,000A
- Maximum Clamp Voltage.....350VAC
- Response Time.....< 200 nanoseconds
- Discharge Voltage.....<200 Volts @ 1,000A
- Insulation Resistance.....≥100 MΩ

Provide conductors for surge protection wiring that are of sufficient size (ampacity) to withstand maximum overcurrents which could occur before protective device thresholds are attained and current flow is interrupted.

If additional surge protected power outlets are needed to accommodate fiber transceivers, modems, etc., install a UL listed, industrial, heavy-duty type power outlet strip with a minimum rating of 15 A / 125 VAC, 60 Hz. Provide a strip that has a minimum of 3 grounded outlets. Ensure the power outlet strip plugs into one of the controller unit receptacles located on the rear of the PDA. Ensure power outlet strip is mounted securely; provide strain relief if necessary.

Provide a door switch in the front and a door switch in the rear of the cabinet that will provide the controller unit with a Door Ajar alarm when either the front or the rear door is open. Ensure the door switches apply DC ground to the Input File when either the front door or the rear door is open.

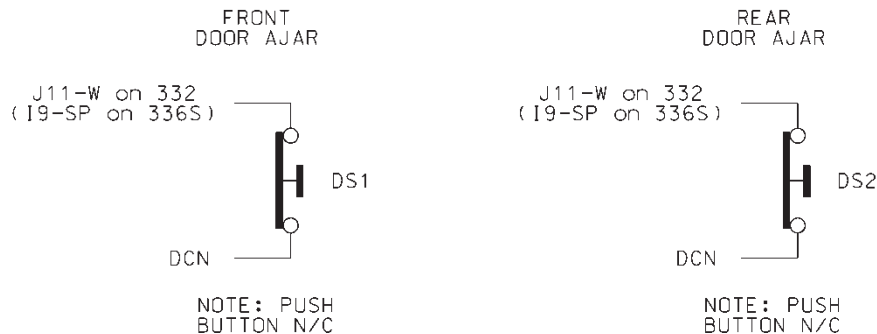

Furnish a fluorescent fixture in the rear across the top of the cabinet and another fluorescent fixture in the front across the top of the cabinet at a minimum. Ensure that the fixtures provide sufficient light to illuminate all terminals, labels, switches, and devices in the cabinet. Conveniently locate the fixtures so as not to interfere with a technician’s ability to perform work on any devices or terminals in the cabinet. Provide a protective diffuser to cover exposed bulbs. Install 16 watt T-4 lamps in the fluorescent fixtures. Provide a door switch to provide power to each fixture when the respective door is open. Wire the fluorescent fixtures to the 15 amp ECB (equipment circuit breaker).

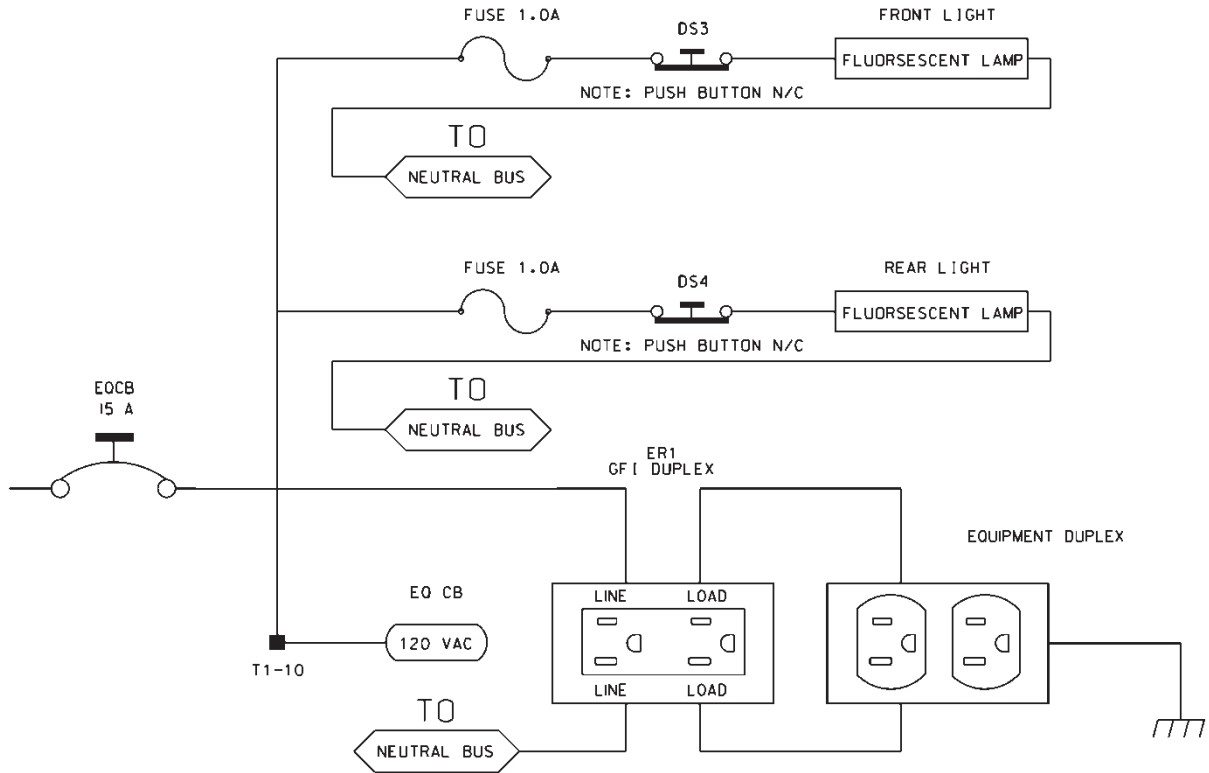

For model 332 base mounted cabinets, ensure terminals J14-E and J14-K are wired together on the rear of the Input File. Connect TB9-12 (J14 Common) on the Input Panel to T1-2 (AC-) on the rear of the PDA.

Provide detector test switches mounted at the top of the cabinet rack or other convenient location which may be used to place a call on each of eight phases based on the chart below. Provide three positions for each switch: On (place call), Off (normal detector operation), and Momentary On (place momentary call and return to normal detector operation after switch is released). Ensure that the switches are located such that the technician can read the controller display and observe the intersection.

Connect detector test switches for cabinets as follows:

332 Cabinet	
Detector Call Switches	Terminals
Phase 1	I1-W
Phase 2	I4-W
Phase 3	I5-W
Phase 4	I8-W
Phase 5	J1-W
Phase 6	J4-W
Phase 7	J5-W
Phase 8	J8-W

Provide the PCB 28/56 connector for the conflict monitor unit (CMU) with 28 independent contacts per side, dual-sided with 0.156 inch contact centers. Provide the PCB 28/56 connector contacts with solder eyelet terminations. Ensure all connections to the PCB 28/56 connector are soldered to the solder eyelet terminations.

Ensure that all cabinets have the CMU connector wired according to the 332 cabinet connector pin assignments (include all wires for auxiliary output file connection). Wire pins 13, 16, R, and U of the CMU connector to a separate 4 pin plug, P1, as shown below. Provide a second plug, P2, which will mate with P1 and is wired to the auxiliary output file as shown below. Provide an additional plug, P3, which will mate with P1 and is wired to the pedestrian yellow circuits as shown below. When no auxiliary output file is installed in the cabinet, provide wires for the green and yellow inputs for channels 11, 12, 17, and 18, the red inputs for channels 17 and 18, and the wires for the P2 plug. Terminate the two-foot wires with ring type lugs, insulated, and bundled for optional use.

PIN	P1		P2		P3	
	FUNCTION	CONN TO	FUNCTION	CONN TO	FUNCTION	CONN TO
1	CH-9G	CMU-13	OLA-GRN	A123	2P-YEL	114
2	CH-9Y	CMU-16	OLA-YEL	A122	4P-YEL	105
3	CH-10G	CMU-R	OLB-GRN	A126	6P-YEL	120
4	CH-10Y	CMU-U	OLB-YEL	A125	8P-YEL	111

Do not provide the P20 terminal assembly (red monitor board) or red interface ribbon cable as specified in LA Specification No. 54-053-08.

Provide a P20 connector that mates with and is compatible with the red interface connector mounted on the front of the conflict monitor. Ensure that the P20 connector and the red interface connector on the conflict monitor are center polarized to ensure proper connection. Ensure that removal of the P20 connector will cause the conflict monitor to recognize a latching fault condition and place the cabinet into flashing operation.

Wire the P20 connector to the output file and auxiliary output file using 22 AWG stranded wires. Ensure the length of these wires is a minimum of 42 inches in length. Provide a durable braided sleeve around the wires to organize and protect the wires.

Wire the P20 connector to the traffic signal red displays to provide inputs to the conflict monitor as shown below. Ensure the pedestrian Don't Walk circuits are wired to channels 13 through 16 of the P20 connector. When no auxiliary output file is installed in the cabinet, provide wires for channels 9 through 12 reds. Provide a wire for special function 1. Terminate the unused wires with ring type lugs, insulated, and bundled for optional use.

P20 Connector					
PIN	FUNCTION	CONN TO	PIN	FUNCTION	CONN TO
1	Channel 15 Red	119	2	Channel 16 Red	110
3	Channel 14 Red	104	4	Chassis GND	01-9
5	Channel 13 Red	113	6	N/C	
7	Channel 12 Red	AUX 101	8	Spec Function 1	
9	Channel 10 Red	AUX 124	10	Channel 11 Red	AUX 114
11	Channel 9 Red	AUX 121	12	Channel 8 Red	107
13	Channel 7 Red	122	14	Channel 6 Red	134
15	Channel 5 Red	131	16	Channel 4 Red	101
17	Channel 3 Red	116	18	Channel 2 Red	128
19	Channel 1 Red	125	20	Red Enable	01-14

Ensure the controller unit outputs to the auxiliary output file are pre-wired to the C5 connector. When no auxiliary output file is installed in the cabinet, connect the C5 connector to a storage socket located on the Input Panel or on the rear of the PDA.

Do not wire pin 12 of the load switch sockets.

In addition to the requirements of LA Specification No. 54-053-08, ensure relay K1 on the Power Distribution Assembly (PDA) is a four pole relay and K2 on the PDA is a two pole relay.

Provide a two pole, ganged circuit breaker for the flash bus circuit. Ensure the flash bus circuit breaker is an inverse time circuit breaker rated for 10 amps at 120 VAC with a minimum of 10,000 RMS symmetrical amperes short circuit current rating. Do not provide the auxiliary switch feature on the flash bus circuit breaker. Ensure the ganged flash bus circuit breaker is certified by the circuit breaker manufacturer to provide ganging tripping operation.

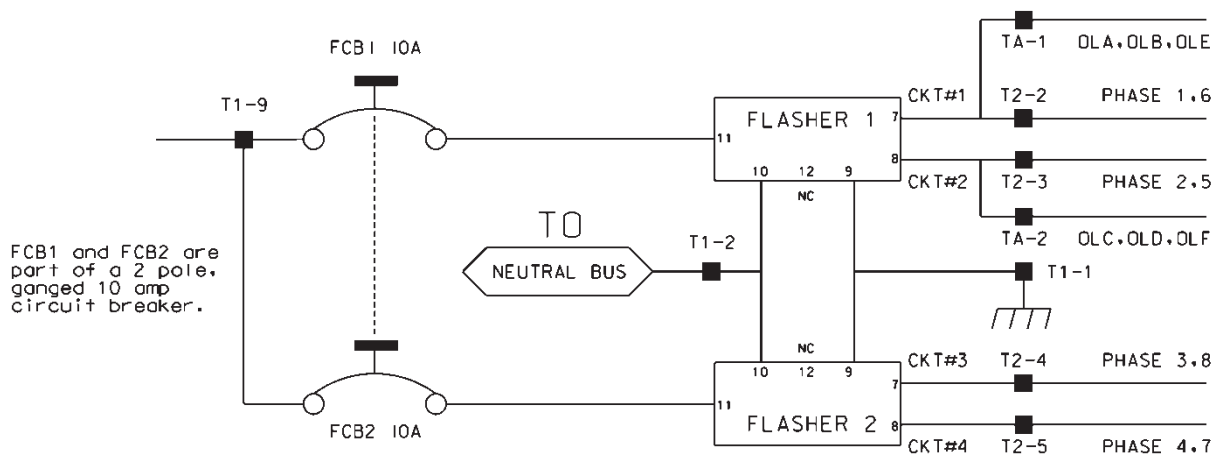

Ensure auxiliary output files are wired as follows:

AUXILIARY OUTPUT FILE TERMINAL BLOCK TA ASSIGNMENTS	
POSITION	FUNCTION
1	Flasher Unit #1, Circuit 1/FTR1 (OLA, OLB)/FTR3 (OLE)
2	Flasher Unit #1, Circuit 2/FTR2 (OLC, OLD)/FTR3 (OLF)
3	Flash Transfer Relay Coils
4	AC -
5	Power Circuit 5
6	Power Circuit 5
7	Equipment Ground Bus
8	NC

Provide four spare load resistors mounted in each cabinet. Ensure each load resistor is rated as shown in the table below. Wire one side of each load resistor to AC-. Connect the other side of each resistor to a separate terminal on a four (4) position terminal block. Mount the load resistors and terminal block either inside the back of Output File No. 1 or on the upper area of the Service Panel.

ACCEPTABLE LOAD RESISTOR VALUES	
VALUE (ohms)	WATTAGE
1.5K – 1.9K	25W (min)
2.0K – 3.0K	10W (min)

Provide Model 200 load switches, Model 204 flashers, Model 242 DC isolators, Model 252 AC isolators, and Model 206L power supply units that conform to CALTRANS’ “*Transportation Electrical Equipment Specifications*” dated March 12, 2009 with Erratum 1.

**C. Type 170 E Cabinet Physical Requirements:**

Do not mold, cast, or scribe the name “City of Los Angeles” on the outside of the cabinet door as specified in LA Specification No. 54-053-08. Do not provide a Communications Terminal Panel as specified in LA Specification No. 54-053-08. Do not provide terminal block TBB on the Service Panel. Do not provide Cabinet Verification Test Program software or associated test jigs as specified in LA Specification No. 54-053-08.

Furnish unpainted, natural, aluminum cabinet shells. Ensure that all non-aluminum hardware on the cabinet is stainless steel or a Department approved non-corrosive alternate.

Ensure the lifting eyes, gasket channels, police panel, and all supports welded to the enclosure and doors are fabricated from 0.125 inch minimum thickness aluminum sheet and meet the same standards as the cabinet and doors.

Provide front and rear doors with latching handles that allow padlocking in the closed position. Furnish 0.75 inch minimum diameter stainless steel handles with a minimum 0.5 inch shank. Place the padlocking attachment at 4.0 inches from the handle shank center to clear the lock and key. Provide an additional 4.0 inches minimum gripping length.

Provide Corbin #2 locks on the front and rear doors. Provide one (1) Corbin #2 and one (1) police master key with each cabinet. Ensure main door locks allow removal of keys in the locked position only.

Provide a surge protection panel with 16 loop surge protection devices and designed to allow sufficient free space for wire connection/disconnection and surge protection device replacement. For model 332 cabinets, provide an additional 20 loop surge protection devices. Provide an additional two AC+ interconnect surge devices to protect one slot and eight DC surge protection devices to protect four slots. Provide no protection devices on slot I14.

For base mounted cabinets, mount surge protection panels on the left side of the cabinet as viewed from the rear. Attach each panel to the cabinet rack assembly using bolts and make it easily removable. Mount the surge protection devices in vertical rows on each panel and connect the devices to one side of 12 position, double row terminal blocks with #8 screws. For each surge protection panel, terminate all grounds from the surge protection devices on a copper equipment ground bus attached to the surge protection panel. Wire the terminals to the rear of a standard input file using spade lugs for input file protection.

Provide permanent labels that indicate the slot and the pins connected to each terminal that may be viewed from the rear cabinet door. Label and orient terminals so that each pair of inputs is next to each other. Indicate on the labeling the input file (I or J), the slot number (1-14) and the terminal pins of the input slots (either D & E for upper or J & K for lower).

Provide a minimum 14 x 16 inch pull out, hinged top shelf located immediately below controller mounting section of the cabinet. Ensure the shelf is designed to fully expose the table surface outside the controller at a height approximately even with the bottom of the controller. Ensure the shelf has a storage bin interior which is a minimum of 1 inch deep and approximately the same dimensions as the shelf. Provide an access to the storage area by lifting the hinged top of the shelf. Fabricate the shelf and slide from aluminum or stainless steel and ensure the assembly can support the 2070L controller plus 15 pounds of additional weight. Ensure shelf has a locking mechanism to secure it in the fully extended position and does not inhibit the removal of the 2070L controller or removal of cards inside the controller when fully extended. Provide a locking mechanism that is easily released when the shelf is to be returned to its non-use position directly under the controller.

#### **D. Model 2018 Enhanced Conflict Monitor:**

Furnish Model 2018 Enhanced Conflict Monitors that provide monitoring of 18 channels. Ensure each channel consists of a green, yellow, and red field signal input. Ensure that the conflict monitor meets or exceeds CALTRANS' Transportation Electrical Equipment Specifications dated March 12, 2009, with Erratum 1 (hereafter referred to as CALTRANS' 2009 TEES) for a model 210 monitor unit and other requirements stated in this specification.

Ensure the conflict monitor is provided with an 18 channel conflict programming card. Pin EE and Pin T of the conflict programming card shall be connected together. Pin 16 of the conflict programming card shall be floating. Ensure that the absence of the conflict programming card will cause the conflict monitor to trigger (enter into fault mode), and remain in the triggered state until the programming card is properly inserted and the conflict monitor is reset.



Provide a conflict monitor that incorporates LED indicators into the front panel to dynamically display the status of the monitor under normal conditions and to provide a comprehensive review of field inputs with monitor status under fault conditions. Ensure that the monitor indicates the channels that were active during a conflict condition and the channels that experienced a failure for all other per channel fault conditions detected. Ensure that these indications and the status of each channel are retained until the Conflict Monitor is reset. Furnish LED indicators for the following:

- AC Power (Green LED indicator)
- VDC Failed (Red LED indicator)
- WDT Error (Red LED indicator)
- Conflict (Red LED indicator)
- Red Fail (Red LED indicator)
- Dual Indication (Red LED indicator)
- Yellow/Clearance Failure (Red LED indicator)
- PCA/PC Ajar (Red LED indicator)
- Monitor Fail/Diagnostic Failure (Red LED indicator)
- 54 Channel Status Indicators (1 Red, 1 Yellow, and 1 Green LED indicator for each of the 18 channels)

Provide a switch to set the Red Fail fault timing. Ensure that when the switch is in the ON position the Red Fail fault timing value is set to 1350 +/- 150 ms (2018 mode). Ensure that when the switch is in the OFF position the Red Fail fault timing value is set to 850 +/- 150 ms (210 mode).

Provide a switch to set the Watchdog fault timing. Ensure that when the switch is in the ON position the Watchdog fault timing value is set to 1.0 +/- 0.1 s (2018 mode). Ensure that when the switch is in the OFF position the Watchdog fault timing value is set to 1.5 +/- 0.1 s (210 mode).

Provide a jumper or switch to set the AC line brown-out levels. Ensure that when the jumper is present or the switch is in the ON position the AC line dropout voltage threshold is 98 +/- 2 Vrms, the AC line restore voltage threshold is 103 +/- 2 Vrms, and the AC line brown-out timing value is set to 400 +/- 50ms (2018 mode). Ensure that when the jumper is not present or the switch is in the OFF position the AC line dropout voltage threshold is 92 +/- 2 Vrms, the AC line restore voltage threshold is 98 +/- 2 Vrms, and the AC line brown-out timing value is set to 80 +/- 17 ms (210 mode).

Provide a jumper or switch that will enable and disable the Watchdog Latch function. Ensure that when the jumper is not present or the switch is in the OFF position the Watchdog Latch function is disabled. In this mode of operation, a Watchdog fault will be reset following a power loss, brownout, or power interruption. Ensure that when the jumper is present or the switch is in the ON position the Watchdog Latch function is enabled. In this mode of operation, a Watchdog fault will be retained until a Reset command is issued.

Provide a jumper that will reverse the active polarity for pin #EE (output relay common). Ensure that when the jumper is not present pin #EE (output relay common) will be considered 'Active' at a voltage greater than 70 Vrms and 'Not Active' at a voltage less than 50 Vrms (Caltrans mode). Ensure that when the jumper is present pin #EE (output relay common) will be considered 'Active' at a voltage less than 50 Vrms and 'Not Active' at a voltage greater than 70 Vrms (Failsafe mode).



U-6202

TS-20

New Hanover County

In addition to the connectors required by CALTRANS' 2009 TEES, provide the conflict monitor with a red interface connector mounted on the front of the monitor. Ensure the connector is a 20 pin, right angle, center polarized, male connector with latching clip locks and polarizing keys. Ensure the right angle solder tails are designed for a 0.062" thick printed circuit board. Keying of the connector shall be between pins 3 and 5, and between 17 and 19. Ensure the connector has two rows of pins with the odd numbered pins on one row and the even pins on the other row. Ensure the connector pin row spacing is 0.10" and pitch is 0.10". Ensure the mating length of the connector pins is 0.24". Ensure the pins are finished with gold plating 30μ" thick.

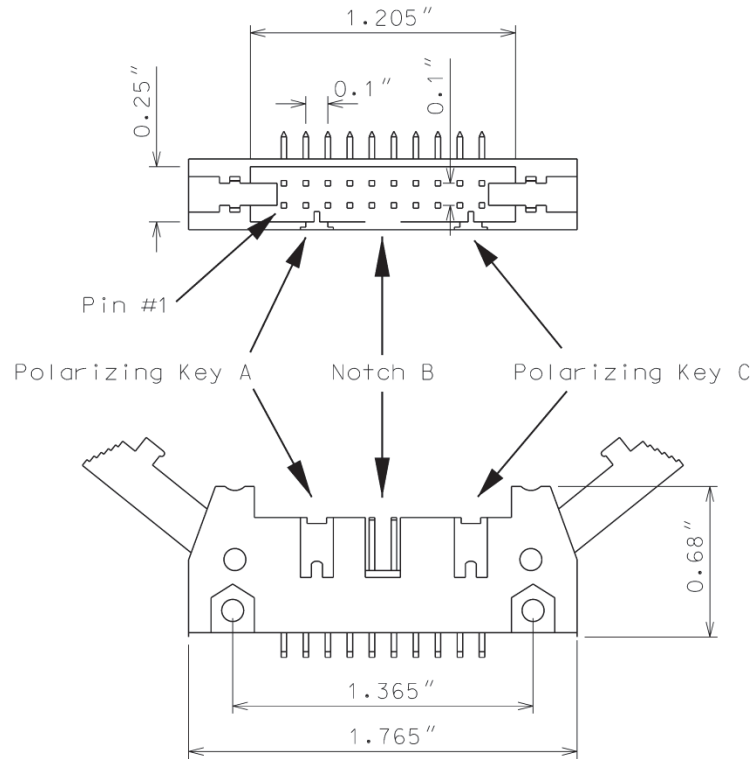

Ensure the red interface connector pins on the monitor have the following functions:

Pin #	Function	Pin #	Function
1	Channel 15 Red	2	Channel 16 Red
3	Channel 14 Red	4	Chassis Ground
5	Channel 13 Red	6	Special Function 2
7	Channel 12 Red	8	Special Function 1
9	Channel 10 Red	10	Channel 11 Red
11	Channel 9 Red	12	Channel 8 Red
13	Channel 7 Red	14	Channel 6 Red
15	Channel 5 Red	16	Channel 4 Red
17	Channel 3 Red	18	Channel 2 Red
19	Channel 1 Red	20	Red Enable

Ensure that removal of the P20 cable connector will cause the conflict monitor to recognize a latching fault condition and place the cabinet into flashing operation.

Provide Special Function 1 and Special Function 2 inputs to the unit which shall disable only Red Fail Monitoring when either input is sensed active. A Special Function input shall be sensed active when the input voltage exceeds 70 Vrms with a minimum duration of 550 ms. A Special Function input shall be sensed not active when the input voltage is less than 50 Vrms or the duration is less than 250 ms. A Special Function input is undefined by these specifications and may or may not be sensed active when the input voltage is between 50 Vrms and 70 Vrms or the duration is between 250 ms and 550 ms.

Ensure the conflict monitor recognizes field signal inputs for each channel that meet the following requirements:

- consider a Red input greater than 70 Vrms and with a duration of at least 500 ms as an “on” condition;
- consider a Red input less than 50 Vrms or with a duration of less than 200 ms as an “off” condition (no valid signal);
- consider a Red input between 50 Vrms and 70 Vrms or with a duration between 200 ms and 500 ms to be undefined by these specifications;
- consider a Green or Yellow input greater than 25 Vrms and with a duration of at least 500 ms as an “on” condition;
- consider a Green or Yellow input less than 15 Vrms or with a duration of less than 200 ms as an “off” condition; and
- consider a Green or Yellow input between 15 Vrms and 25 Vrms or with a duration between 200 ms and 500 ms to be undefined by these specifications.

Provide a conflict monitor that recognizes the faults specified by CALTRANS’ 2009 TEES and the following additional faults. Ensure the conflict monitor will trigger upon detection of a fault and

will remain in the triggered (in fault mode) state until the unit is reset at the front panel or through the external remote reset input for the following failures:

1. **Red Monitoring or Absence of Any Indication (Red Failure):** A condition in which no “on” voltage signal is detected on any of the green, yellow, or red inputs to a given monitor channel. If a signal is not detected on at least one input (R, Y, or G) of a conflict monitor channel for a period greater than 1000 ms when used with a 170 controller and 1500 ms when used with a 2070 controller, ensure monitor will trigger and put the intersection into flash. If the absence of any indication condition lasts less than 700 ms when used with a 170 controller and 1200 ms when used with a 2070 controller, ensure conflict monitor will not trigger. Red fail monitoring shall be enabled on a per channel basis by the use of switches located on the conflict monitor. Have red monitoring occur when all of the following input conditions are in effect:
  - a) Red Enable input to monitor is active (Red Enable voltages are “on” at greater than 70 Vrms, off at less than 50 Vrms, undefined between 50 and 70 Vrms), and
  - b) Neither Special Function 1 nor Special Function 2 inputs are active.
  - c) Pin #EE (output relay common) is not active
2. **Short/Missing Yellow Indication Fault (Clearance Error):** Yellow indication following a green is missing or shorter than 2.7 seconds (with  $\pm 0.1$ -second accuracy). If a channel fails to detect an “on” signal at the Yellow input for a minimum of 2.7 seconds ( $\pm 0.1$  second) following the detection of an “on” signal at a Green input for that channel, ensure that the monitor triggers and generates a clearance/short yellow error fault indication. Short/missing yellow (clearance) monitoring shall be enabled on a per channel basis by the use of switches located on the conflict monitor. This fault shall not occur when the channel is programmed for Yellow Inhibit, when the Red Enable signal is inactive or pin #EE (output relay common) is active.
3. **Dual Indications on the Same Channel:** In this condition, more than one indication (R,Y,G) is detected as “on” at the same time on the same channel. If dual indications are detected for a period greater than 500 ms, ensure that the conflict monitor triggers and displays the proper failure indication (Dual Ind fault). If this condition is detected for less than 200 ms, ensure that the monitor does not trigger. G-Y-R dual indication monitoring shall be enabled on a per channel basis by the use of switches located on the conflict monitor. G-Y dual indication monitoring shall be enabled for all channels by use of a switch located on the conflict monitor. This fault shall not occur when the Red Enable signal is inactive or pin #EE (output relay common) is active.
4. **Configuration Settings Change:** The configuration settings are comprised of (as a minimum) the permissive diode matrix, dual indication switches, yellow disable jumpers, any option switches, any option jumpers, and the Watchdog Enable switch. Ensure the conflict monitor compares the current configuration settings with the previous stored configuration settings on power-up, on reset, and periodically during operation. If any of the configuration settings are changed, ensure that the conflict monitor triggers and causes the program card

indicator to flash. Ensure that configuration change faults are only reset by depressing and holding the front panel reset button for a minimum of three seconds. Ensure the external remote reset input does not reset configuration change faults.

Ensure the conflict monitor will trigger and the AC Power indicator will flash at a rate of 2 Hz ± 20% with a 50% duty cycle when the AC Line voltage falls below the “drop-out” level. Ensure the conflict monitor will resume normal operation when the AC Line voltage returns above the “restore” level. Ensure the AC Power indicator will remain illuminated when the AC voltage returns above the “restore” level. Should an AC Line power interruption occur while the monitor is in the fault mode, then upon restoration of AC Line power, the monitor will remain in the fault mode and the correct fault and channel indicators will be displayed.

Provide a flash interval of at least 6 seconds and at most 16 seconds in duration following a power-up, an AC Line interruption, or a brownout restore. Ensure the conflict monitor will suspend all fault monitoring functions, close the Output relay contacts, and flash the AC indicator at a rate of 4 Hz ± 20% with a 50% duty cycle during this interval. Ensure the termination of the flash interval after at least 6 seconds if the Watchdog input has made 5 transitions between the True and False state and the AC Line voltage is greater than the “restore” level. If the watchdog input has not made 5 transitions between the True and False state within 10 ± 0.5 seconds, the monitor shall enter a WDT error fault condition.

Ensure the conflict monitor will monitor an intersection with a minimum of four approaches using the four-section Flashing Yellow Arrow (FYA) vehicle traffic signal as outlined by the NCHRP 3-54 research project for protected-permissive left turn signal displays. Ensure the conflict monitor will operate in the FYA mode and FYAc (Compact) mode as specified below to monitor each channel pair for the following fault conditions: Conflict, Flash Rate Detection, Red Fail, Dual Indication, and Clearance. Provide a switch to select between the FYA mode and FYAc mode. Provide a switch to select each FYA phase movement for monitoring.

**FYA mode**

FYA Signal Head	Phase 1	Phase 3	Phase 5	Phase 7
Red Arrow	Channel 9 Red	Channel 10 Red	Channel 11 Red	Channel 12 Red
Yellow Arrow	Channel 9 Yellow	Channel 10 Yellow	Channel 11 Yellow	Channel 12 Yellow
Flashing Yellow Arrow	Channel 9 Green	Channel 10 Green	Channel 11 Green	Channel 12 Green
Green Arrow	Channel 1 Green	Channel 3 Green	Channel 5 Green	Channel 7 Green

FYAc mode

FYA Signal Head	Phase 1	Phase 3	Phase 5	Phase 7
Red Arrow	Channel 1 Red	Channel 3 Red	Channel 5 Red	Channel 7 Red
Yellow Arrow	Channel 1 Yellow	Channel 3 Yellow	Channel 5 Yellow	Channel 7 Yellow
Flashing Yellow Arrow	Channel 1 Green	Channel 3 Green	Channel 5 Green	Channel 7 Green
Green Arrow	Channel 9 Green	Channel 9 Yellow	Channel 10 Green	Channel 10 Yellow

If a FYA channel pair is enabled for FYA operation, the conflict monitor will monitor the FYA logical channel pair for the additional following conditions:

1. **Conflict:** Channel conflicts are detected based on the permissive programming jumpers on the program card. This operation remains unchanged from normal operation except for the solid Yellow arrow (FYA clearance) signal.
2. **Yellow Change Interval Conflict:** During the Yellow change interval of the Permissive Turn channel (flashing Yellow arrow) the conflict monitor shall verify that no conflicting channels to the solid Yellow arrow channel (clearance) are active. These conflicting channels shall be determined by the program card compatibility programming of the Permissive Turn channel (flashing Yellow arrow). During the Yellow change interval of the Protected Turn channel (solid Green arrow) the conflict monitor shall verify that no conflicting channels to the solid Yellow arrow channel (clearance) are active as determined by the program card compatibility programming of the Protected Turn channel (solid Green arrow).
3. **Flash Rate Detection:** The conflict monitor unit shall monitor for the absence of a valid flash rate for the Permissive turn channel (flashing Yellow arrow). If the Permissive turn channel (flashing Yellow arrow) is active for a period greater than 1600 milliseconds, ensure the conflict monitor triggers and puts the intersection into flash. If the Permissive turn channel (flashing Yellow arrow) is active for a period less than 1400 milliseconds, ensure the conflict monitor does not trigger. Ensure the conflict monitor will remain in the triggered (in fault mode) state until the unit is reset at the front panel or through the external remote reset input. Provide a jumper or switch that will enable and disable the Flash Rate Detection function. Ensure that when the jumper is not present or the switch is in the OFF position the Flash Rate Detection function is enabled. Ensure that when the jumper is present or the switch is in the ON position the Flash Rate Detection function is disabled.
4. **Red Monitoring or Absence of Any Indication (Red Failure):** The conflict monitor unit shall detect a red failure if there is an absence of voltage on all four of the inputs of a FYA channel pair (RA, YA, FYA, GA).
5. **Dual Indications on the Same Channel:** The conflict monitor unit shall detect a dual indication if two or more inputs of a FYA channel pair (RA, YA, FYA, GA) are “on” at the same time.

6. **Short/Missing Yellow Indication Fault (Clearance Error):** The conflict monitor unit shall monitor the solid Yellow arrow for a clearance fault when terminating both the Protected Turn channel (solid Green arrow) interval and the Permissive Turn channel (flashing Yellow arrow) interval.

Ensure that the conflict monitor will log at least nine of the most recent events detected by the monitor in non-volatile EEPROM memory (or equivalent). For each event, record at a minimum the time, date, type of event, status of each field signal indication with RMS voltage, and specific channels involved with the event. Ensure the conflict monitor will log the following events: monitor reset, configuration, previous fault, and AC line. Furnish the signal sequence log that shows all channel states (Greens, Yellows, and Reds) and the Red Enable State for a minimum of 2 seconds prior to the current fault trigger point. Ensure the display resolution of the inputs for the signal sequence log is not greater than 50 ms.

For conflict monitors used within an Ethernet communications system, provide a conflict monitor with an Ethernet 10/100 Mbps, RJ-45 port for data communication access to the monitor by a local notebook computer and remotely via a workstation or notebook computer device connected to the signal system local area network. The Ethernet port shall be electrically isolated from the conflict monitor's electronics and shall provide a minimum of 1500 Vrms isolation. Integrate monitor with Ethernet network in cabinet. Provide software to retrieve the time and date from a network server in order to synchronize the on-board times between the conflict monitor and the controller. Furnish and install the following Windows based, graphic user interface software on workstations and notebook computers where the signal system client software is installed: 1) software to view and retrieve all event log information, 2) software that will search and display a list of conflict monitor IP addresses and IDs on the network, and 3) software to change the conflict monitor's network parameters such as IP address and subnet mask.

For non-Ethernet connected monitors, provide a RS-232C/D compliant port (DB-9 female connector) on the front panel of the conflict monitor in order to provide communications from the conflict monitor to the 170/2070 controller or to a Department-furnished laptop computer. Electrically isolate the port interface electronics from all monitor electronics, excluding Chassis Ground. Ensure that the controller can receive all event log information through a controller Asynchronous Communications Interface Adapter (Type 170E) or Async Serial Comm Module (2070). Furnish and connect a serial cable from the conflict monitor's DB-9 connector to Comm Port 1 of the 2070 controller. Ensure conflict monitor communicates with the controller. Provide a Windows based graphic user interface software to communicate directly through the same monitor RS-232C/D compliant port to retrieve and view all event log information to a Department-furnished laptop computer. The RS-232C/D compliant port on the monitor shall allow the monitor to function as a DCE device with pin connections as follows:

U-6202

TS-26

New Hanover County

<b>Conflict Monitor RS-232C/D (DB-9 Female) Pinout</b>		
<b>Pin Number</b>	<b>Function</b>	<b>I/O</b>
1	DCD	O
2	TX Data	O
3	RX Data	I
4	DTR	I
5	Ground	-
6	DSR	O
7	CTS	I
8	RTS	O
9	NC	-

U-6202

TS-27

New Hanover County

---

**MONITOR BOARD EDGE CONNECTOR**

---

<b>Pin #</b>	<b>Function (Back Side)</b>	<b>Pin #</b>	<b>Function (Component Side)</b>
1	Channel 2 Green	A	Channel 2 Yellow
2	Channel 13 Green	B	Channel 6 Green
3	Channel 6 Yellow	C	Channel 15 Green
4	Channel 4 Green	D	Channel 4 Yellow
5	Channel 14 Green	E	Channel 8 Green
6	Channel 8 Yellow	F	Channel 16 Green
7	Channel 5 Green	H	Channel 5 Yellow
8	Channel 13 Yellow	J	Channel 1 Green
9	Channel 1 Yellow	K	Channel 15 Yellow
10	Channel 7 Green	L	Channel 7 Yellow
11	Channel 14 Yellow	M	Channel 3 Green
12	Channel 3 Yellow	N	Channel 16 Yellow
13	Channel 9 Green	P	Channel 17 Yellow
14	Channel 17 Green	R	Channel 10 Green
15	Channel 11 Yellow	S	Channel 11 Green
16	Channel 9 Yellow	T	Channel 18 Yellow
17	Channel 18 Green	U	Channel 10 Yellow
--		--	
18	Channel 12 Yellow	V	Channel 12 Green
19	Channel 17 Red	W	Channel 18 Red
20	Chassis Ground	X	Not Assigned
21	AC-	Y	DC Common
22	Watchdog Timer	Z	External Test Reset
23	+24VDC	AA	+24VDC
24	Tied to Pin 25	BB	Stop Time (Output)
25	Tied to Pin 24	CC	Not Assigned
26	Not Assigned	DD	Not Assigned
27	Relay Output, Side #3, N.O.	EE	Relay Output, Side #2, Common
28	Relay Output, Side #1, N.C.	FF	AC+

-- Slotted for keying between Pins 17/U and 18/V



**CONFLICT PROGRAM CARD PIN ASSIGNMENTS**

<b>Pin #</b>	<b>Function (Back Side)</b>	<b>Pin #</b>	<b>Function (Component Side)</b>
1	Channel 2 Green	A	Channel 1 Green
2	Channel 3 Green	B	Channel 2 Green
3	Channel 4 Green	C	Channel 3 Green
4	Channel 5 Green	D	Channel 4 Green
5	Channel 6 Green	E	Channel 5 Green
6	Channel 7 Green	F	Channel 6 Green
7	Channel 8 Green	H	Channel 7 Green
8	Channel 9 Green	J	Channel 8 Green
9	Channel 10 Green	K	Channel 9 Green
10	Channel 11 Green	L	Channel 10 Green
11	Channel 12 Green	M	Channel 11 Green
12	Channel 13 Green	N	Channel 12 Green
13	Channel 14 Green	P	Channel 13 Green
14	Channel 15 Green	R	Channel 14 Green
15	Channel 16 Green	S	Channel 15 Green
16	N/C	T	PC AJAR
17	Channel 1 Yellow	U	Channel 9 Yellow
18	Channel 2 Yellow	V	Channel 10 Yellow
19	Channel 3 Yellow	W	Channel 11 Yellow
20	Channel 4 Yellow	X	Channel 12 Yellow
21	Channel 5 Yellow	Y	Channel 13 Yellow
22	Channel 6 Yellow	Z	Channel 14 Yellow
23	Channel 7 Yellow	AA	Channel 15 Yellow
24	Channel 8 Yellow	BB	Channel 16 Yellow
--		--	
25	Channel 17 Green	CC	Channel 17 Yellow
26	Channel 18 Green	DD	Channel 18 Yellow
27	Channel 16 Green	EE	PC AJAR (Program Card)
28	Yellow Inhibit Common	FF	Channel 17 Green

-- Slotted for keying between Pins 24/BB and 25/CC

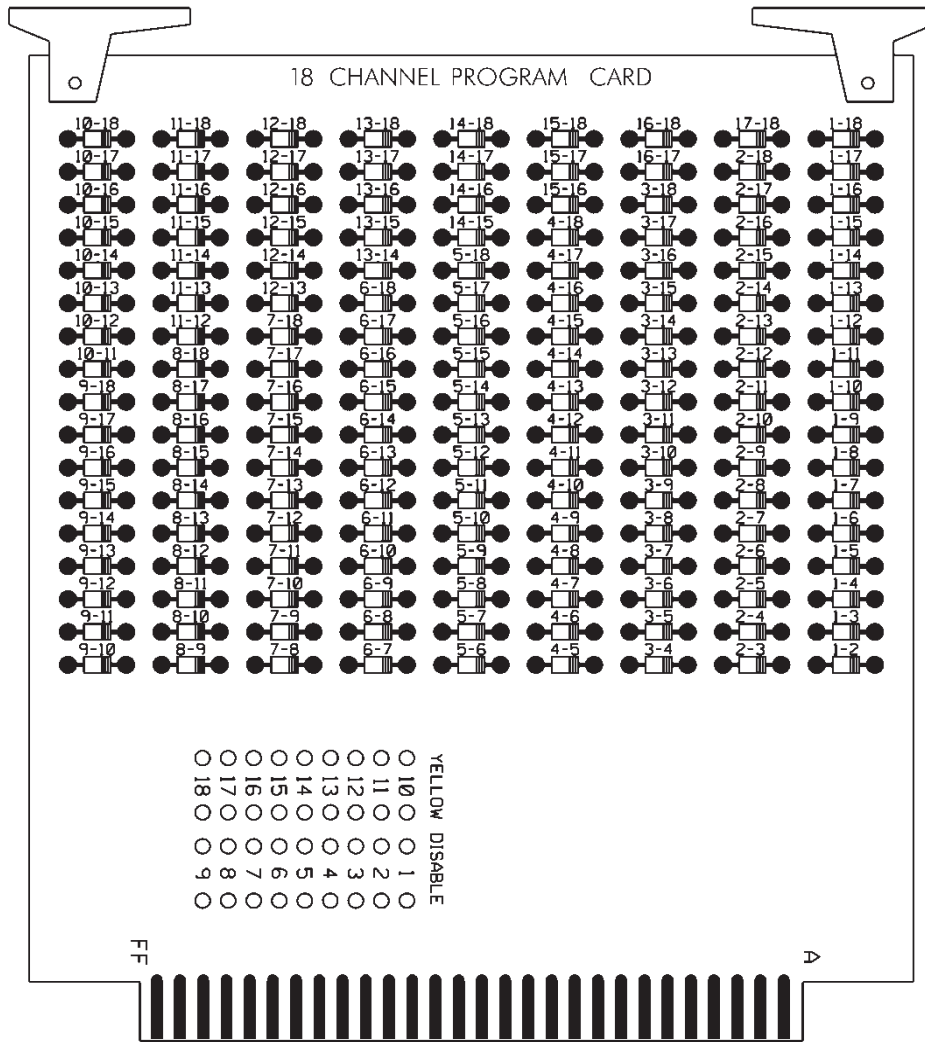

**3.4. MATERIALS – TYPE 170 DETECTOR SENSOR UNITS**

Furnish detector sensor units that comply with Chapter 5 Section 1, “General Requirements,” and Chapter 5 Section 2, “Model 222 & 224 Loop Detector Sensor Unit Requirements,” of the CALTRANS “Transportation Electrical Equipment Specifications” dated March 12, 2009 with Erratum 1.

**3.5. MEASUREMENT AND PAYMENT**

*Install Department Supplied 2070 Controller* will be measured and paid as the actual number of Department Supplied 2070 Controllers installed and accepted.

*Cabinet without Controller* (\_\_\_\_\_) will be measured and paid as the actual number of each type of Cabinets without Controllers (\_\_\_\_\_) furnished, installed, and accepted.

Payment will be made under:

Pay Item	Pay Unit
Install Department Supplied 2070 Controller .....	Each
Cabinet without Controller (_____) .....	Each

#### 4. MICROWAVE VEHICLE DETECTION SYSTEM - MULTIPLE DETECTION ZONES

##### 4.1. DESCRIPTION

Design, furnish and install a microwave vehicle detection system with the manufacturer recommended cables and hardware in accordance to the plans and specifications. Ensure the detection system provides multiple detection zones.

##### 4.2. MATERIALS

Provide design drawings showing design details and microwave sensor locations for review and acceptance before installation. Provide mounting height and location requirements for microwave sensor units on the design based on a site survey. Design microwave vehicle detection system with all necessary hardware. Indicate all necessary poles, spans, mast arms, luminaire arms, cables, microwave sensor mounting assemblies and hardware to achieve the required detection zones where Department owned poles are not adequate to locate the microwave sensor units. Do not design for the installation of poles in medians.

Obtain the Engineer's approval before furnishing microwave vehicle detection system. The contractor is responsible for the final design of microwave vehicle detection system. Review and acceptance of the designs by the Department does not relieve the contractor from the responsibility to provide fully functional systems and to ensure that the required detection zones can be provided. With the exception of contractor-furnished poles, mast arms, and luminaire arms, furnish material, equipment, and hardware under this section that is pre-approved on the ITS and Signals QPL. Submit and obtain Engineer's approval of shop drawings for any poles, mast arms, and luminaire arms provided by the contractor prior to ordering from manufacturer.

Provide a detector for either side-fire or forward-fire configuration. Ensure the detector will detect vehicles in sunny, cloudy, rainy, snowy, and foggy weather conditions. Ensure the detector can operate from the voltage supplied by a NEMA TS-1/TS-2 or Type 332 or 336 traffic signal cabinet. Ensure the detector can provide detection calls to the traffic signal controller within a NEMA TS-1/TS-2 or Type 332 or 336 cabinet. Ensure the detection system provides a constant call in the event of a component failure or loss of power. Ensure the detector has an operating temperature range of -30 to 165 degrees F and operates within the frequency range of 10 to 25 GHz. Ensure the detector is provided with a water-tight housing offering NEMA 4X protection and operates properly in up to 95% relative humidity, non-condensing.

Provide each detector unit to allow the placement of at least 8 detection zones with a minimum of 8 detection channel outputs. When the microwave vehicle detection system requires an integrated card rack interface(s), provide only enough interface cards to implement the vehicle detection shown on the signal plans. Provide a means acceptable to the Engineer to configure traffic lanes and detection zones. Provide each channel output with a programmable means to delay the output call upon activation of a detection zone that is adjustable in one second increments (maximum) over the range of 0 to 25 seconds. Provide each channel output with a programmable means to extend the output call that is adjustable in one second increments (maximum) over the range of 0 to 25 seconds. Ensure both delay and extend timing can be set for the same channel output.

For advance detection system, ensure the detector senses vehicles in motion at a range of 50 to 400 feet from the detector unit for forward-fire configuration and a range of 50 to 200 feet from the detector unit for side-fire configuration with an accuracy of 95% for both configurations. Ensure the advance detection system provides each channel output call of at least 100 ms in duration.

For stop bar presence detection system, ensure the detector outputs a constant call while a vehicle is in the detection zone and removes the call after all vehicles exit the detection zone.

Ensure the presence detector unit can cover a detection zone as shown on the plans and has an effective range of 10 to 120 feet from the detector unit.

For units without an integrated card rack interface, provide Form C output relay contacts rated a minimum of 3A, 24VDC.

If a laptop is used to adjust detector settings, ensure that software is licensed for use by the Department and by any other agency responsible for maintaining or operating the microwave detection system. Provide the Department with a license to duplicate and distribute the software as necessary for design and maintenance support.

After initial detector configuration and installation, ensure routine adjustments or calibration are not needed to maintain acceptable performance.

**4.3. CONSTRUCTION METHODS**

Install the microwave vehicle detection system in accordance with the manufacturer’s recommendations.

Monitor and maintain each detector unit during construction to ensure microwave vehicle detection system is functioning properly and aimed for the detection zone shown in the plans. Refer to Subarticle 1700-3 (D) Maintenance and Repair of Materials of the *Standard Specifications* for failure to maintain the microwave detection system.

**4.4. MEASUREMENT AND PAYMENT**

*Microwave Vehicle Detection System – Multiple Zones* will be measured and paid as the actual number of microwave vehicle detection systems – multiple zones furnished, installed, and accepted.

No measurement will be made of cables or hardware, as these will be considered incidental to furnishing and installing microwave vehicle detection systems.

Payment will be made under:

<b>Pay Item</b>	<b>Pay Unit</b>
Microwave Vehicle Detection System – Multiple Zones .....	Each

**5. METAL POLE SUPPORTS**

**5.1. METAL POLES**

**A. General:**

Furnish and install metal poles, grounding systems, and all necessary hardware. Work covered under this special provision includes requirements for design, fabrication, and installation of standard and custom/site-specific designed metal pole supports and associated foundations.

Comply with applicable sections of the *2024 STANDARD SPECIFICATIONS FOR ROADS & STRUCTURES*, hereinafter referred to as the *Standard Specifications*. Provide designs of completed assemblies with hardware equaling or exceeding *AASHTO LRFD Specifications for Structural Supports for Highway Signs, Luminaires and Traffic Signals* 1<sup>st</sup> Edition, 2015 (hereinafter called 1<sup>st</sup> Edition AASHTO), including the latest interim specifications. Provide assemblies with a round or near-round (18 sides or more) cross-section, or a multi-sided cross section with no less than six sides. The sides may be straight, convex, or concave.

For bid purposes, pole heights shown on plans are estimated from available data. Prior to furnishing metal poles, use field measurements and adjusted cross-sections to determine whether

pole heights will meet required clearances. If pole heights do not meet required clearances, the Contractor should immediately notify the Engineer of the required revised pole heights.

Standard Drawings for Metal Poles are available that supplement these project special provisions. The drawings are located on the Department’s website:

<https://connect.ncdot.gov/resources/safety/pages/ITS-Design-Resources.aspx>

Comply with article 1098-1(B) of the *Standard Specifications* for submittal requirements. Furnish shop drawings for approval. Provide copies of detailed shop drawings for each type of structure as summarized below. Ensure shop drawings include material specifications for each component. Ensure shop drawings identify welds by type and size on the detail drawing only, not in table format. **Do not release structures for fabrication until shop drawings have been approved by NCDOT.** Ensure shop drawings contain an itemized bill of materials for all structural components and associated connecting hardware.

Comply with article 1098-1(A) of the *Standard Specifications* for Qualified Products List (QPL) submittals. All shop drawings must include project location description, signal or asset inventory number(s) and project number or work order number.

Summary of information required for metal pole review submittal:

Item	Electronic Submittal	Comments / Special Instructions
Sealed, Approved Signal or ITS Plan/Loading Diagram	1 set	All structure design information needs to reflect the latest approved Signal or ITS plans
Custom Pole Shop Drawings	1 set	Submit drawings on 11” x 17” format media. Show NCDOT signal or asset inventory number(s), Contractor’s name and relevant revision number in the title block. All drawings must have a <u>unique drawing number</u> for each project.
Standard Strain Pole Shop Drawings (from the QPL)	1 set	Submit drawings on 11” x 17” format media. Show NCDOT signal inventory number(s), Contractor’s name and relevant revision number in the title block. All drawings must have a <u>unique drawing number</u> for each project.
Structure Calculations	1 set	Not required for Standard QPL Poles
Standard Strain Pole Foundation Drawings	1 set	Submit drawings on 11” x 17” format media. Submit a completed Standard Foundation Selection form for each pole using foundation table on Metal Pole Drawing M8.
Custom Foundation Drawings	1 set	Submit drawings on 11” x 17” format media. Show NCDOT signal or asset inventory number(s), Contractor’s name and relevant revision number in the title block. All drawings must have a <u>unique drawing number</u> for each project.  If QPL Poles are used, include the corresponding QPL pole shop drawings with this submittal.

Foundation Calculations	1 set	<p><b>Submit copies of LPILE input, output, and pile tip deflection graph per Section titled Drilled Pier Foundations for Metal Poles of this specification for each foundation.</b></p> <p>Not required for Standard Strain Poles (from the QPL)</p>
Soil Boring Logs and Report	1 set	<p>Report shall include a location plan and a soil classification report including soil capacity, water level, hammer efficiency, soil bearing pressure, soil density, etc. for each pole.</p>

**NOTE** – All shop drawings and custom foundation design drawings must be sealed by a Professional Engineer licensed in the state of North Carolina. All geotechnical information must be sealed by either a Professional Engineer or Geologist licensed in the state of North Carolina. Include a title block and revision block on the shop drawings and foundation drawings showing the NCDOT signal or asset inventory number(s).

**Shop drawings and foundation drawings may be submitted together or separately for approval. However, shop drawings must be approved before foundations can be reviewed.** Foundation designs will be returned without review if the associated shop drawing has not been approved. Boring reports shall include the following: Engineer’s summary, boring location maps, soil classification per AASHTO Classification System, hammer efficiency, and Metal Pole Standard Foundation Selection Form. Incomplete submittals will be returned without review. The Reviewer has the right to request additional analysis and copies of the calculations to expedite the approval process.

**B. Materials:**

Fabricate metal pole from coil or plate steel that meet the requirements of ASTM A 572 Gr 55 or ASTM A 595 Grade A tubes. For structural steel shapes, plates, and bars use, as a minimum, ASTM A572 Gr 50, AASHTO M270 Gr 50, ASTM A709 Gr 50, or an approved equivalent. Provide pole shafts of round or near round (18 sides or more) cross-section, or multi-sided tubular cross-section with no less than six sides, having a uniform linear taper of 0.14 in/ft. Construct shafts from one piece of single-ply plate or coil. For anchor base fabrication, conform to the applicable bolt pattern and orientation as shown on Metal Pole Standard Drawing Sheet M2.

Use the submerged arc process, or other NCDOT previously approved process suitable for shafts, to continuously weld pole shafts along their entire length. Finish the longitudinal seam weld flush with the outside contour of the base metal. Ensure shaft has no circumferential welds except at the lower end joining the shaft to the pole base. Use full penetration groove welds with backing ring for all tube-to-transverse-plate connections in accordance with 1<sup>st</sup> Edition AASHTO. Provide welding that conforms to Article 1072-18 of the *Standard Specifications*. No field welding on any part of the pole will be permitted unless approved by a qualified Engineer.

After fabrication, hot-dip galvanize steel poles and all assembly components in accordance with section 1076-3 of the *Standard Specifications*. Design structural assemblies with weep holes large enough and properly located to drain molten zinc during the galvanization process. Galvanize hardware in accordance with section 1076-4 of the *Standard Specifications*. Ensure threaded material is brushed and retapped as necessary after galvanizing. Perform repair of damaged galvanizing in accordance with section 1076-7 of the *Standard Specifications*. *Ensure* all hardware is galvanized steel or stainless steel. The Contractor is responsible for ensuring the



Designer/Fabricator specifies connecting hardware and/or materials that prevent a dissimilar metal corrosive reaction.

Ensure each anchor rod is 2-inch minimum diameter and 60-inch length. Provide 10-inch minimum thread projection at the top of the rod, and 8-inch minimum at the bottom of the rod. Use anchor rod assembly and drilled pier foundation materials complying with SP09\_R005, hereinafter referred to as *Foundations and Anchor Rod Assemblies for Metal Poles*.

Ensure anchor bolt hole diameters are ¼-inch larger than the anchor bolt diameters in the base plate.

Provide a circular anchor bolt lock plate securing the anchor bolts at the embedded end with two (2) washers and two (2) nuts. Provide a base plate template matching the bolt circle diameter of the anchor bolt lock plate. Construct plates and templates from ¼-inch minimum thick steel with a minimum width of 4 inches. Hot-dip galvanizing is not required for both plates.

Provide four (4) heavy hex nuts and four (4) flat washers for each anchor bolt. For nuts, use AASHTO M291 grade 2H, DH, or DH3 or equivalent material. For flat washers, use AASHTO M293 or equivalent material. Ensure anchor bolts have required diameters, lengths, and positions, and will develop strengths comparable to their respective poles.

For each pole, provide a grounding lug with a ½-inch minimum thread diameter, coarse thread stud and nut that will accommodate #4 AWG ground wire. Ensure the lug is electrically bonded to the pole and is conveniently located inside the pole at the hand hole.

Provide a removable pole cap with stainless steel attachment screws for the top of each pole. Ensure cap is cast aluminum conforming to Aluminum Association Alloy 356.0F. Furnish cap attached to the pole with a sturdy stainless-steel chain that is long enough to permit cap to hang clear of the pole-top opening when cap is removed.

Where required by the plans, furnish couplings 42 inches above bottom of the pole base for mounting of pedestrian pushbuttons. Provide mounting points consisting of 1½-inch internally threaded half-couplings complying with the NEC, mounted within the poles. Ensure that couplings are essentially flush with the outside surfaces of the poles and are installed before any required hot-dip galvanizing. Provide a threaded plug in each mounting point. Ensure the surface of the plug is essentially flush with the outer end of the mounting point when installed and has a recessed slot that will accommodate a ½" drive standard socket wrench.

Metal poles may be erected and fully loaded after concrete has attained a minimum allowable compressive strength of 3,000 psi.

Connect poles to grounding electrodes and bond them to the electrical service grounding electrodes.

When field drilling is necessary for wire or cable entrances into the pole, comply with the following requirements:

- Do not drill holes within 2 inches of any welds.
- Do not drill any holes larger than 3 inches in diameter without checking with the ITS & Signals Structure Engineers.
- Avoid drilling multiple holes along the same cross section of tube shafts.
- Install rubber grommets in all field drilled holes that wire, or cable will directly enter unless holes are drilled for installation of weather heads or couplings.

- Treat the inside of the drilled holes and repair all galvanized surfaces in accordance with Section 1076-7 of the latest edition of the *Standard Specification* prior to installing grommets, caps, or plugs.
- Cap or plug any existing field drilled holes that are no longer used with rubber, aluminum, or stainless-steel hole plugs.

When street lighting is installed on metal signal structures, isolate the conductors feeding the luminaires inside the pole shaft using liquid tight flexible metal conduit (Type LFMC), liquid tight flexible nonmetallic conduit (Type LFNC), high density polyethylene conduit (Type HDPE), or approved equivalent. All conductors supplying power for luminaires must run through an external disconnect prior to entrance into the structure. In accordance with the National Electrical Code (NEC) Article 230.2(E), provide identification of the electrical source provider for the luminaire feeder circuit with contact information on a permanent label located in the pole hand hole near the feeder circuit raceway.

Install a ¼-inch thick plate for a concrete foundation tag to include the following information: concrete grade, depth, diameter, and reinforcement sizes of the installed foundation. Install galvanized wire mesh to cover gap between the base plate and top of foundation for debris and pest control. Refer to standard drawing M7 for further details.

Immediately notify the Engineer of any structural deficiency that becomes apparent in any assembly, or member of any assembly, because of the design requirements imposed by these specifications, the plans, or the typical drawings.

### C. Design:

Unless otherwise specified, design all metal pole support structures using the following 1<sup>st</sup> Edition AASHTO specifications:

- Use 700-Year MRI and 10-Year MRI wind pressure maps developed from 3-second gust speeds, as provided in Section 3.8.
- Ensure metal pole support structures include natural wind gust loading and truck-induced gust loading for fatigue design, as provided in Sections 11.7.1.2 and 11.7.1.3, respectively. Designs need not consider periodic galloping forces.
- Assume 11.2 mph natural wind gust speed in North Carolina. For natural wind fatigue stress calculations, utilize a drag coefficient ( $C_d$ ) based on the yearly mean wind velocity of 11.2 mph.
- When selecting Fatigue Importance Factors, utilize Fatigue Importance Category II, as provided for in Table 11.6-1, unless otherwise specified.
- Calculate all forces using applicable equations from Section 5. The Maximum allowable force ratio for all metal pole support designs is 0.9.
- Conform to Sections 10.4.2 and 11.8 for deflection requirements. For CCTV and MVD support structures, ensure maximum deflection at top of pole does not exceed 2.0 percent of pole height.
- Assume the combined minimum weight of a messenger cable bundle (including messenger cable, signal cable and detector lead-in cables) is 1.3 lbs/ft. Assume the combined minimum diameter of the cable bundle is 1.3 inches.
- All CCTV and MVD poles shall meet the compact section limits per section 5.7.2 along with Table 5.7.2-1. Minimum thickness of CCTV and MVD pole shafts shall be ¼-inch.



- All CCTV and MVD poles shall use full-penetration groove weld tube-to-transverse plate connection with backing ring. Refer to Metal Pole Standard Drawing Sheet M9 for details. Fillet-welded tube-to-transverse-plate connections are not permitted.

Unless otherwise specified by special loading criteria, the following computed surface area for ice load on signal heads shall be used:

- 3-section, 12-inch, Surface area: 26.0 ft<sup>2</sup>
- 4-section, 12-inch, Surface area: 32.0 ft<sup>2</sup>
- 5-section, 12-inch, Surface area: 42.0 ft<sup>2</sup>

Design a base plate for each pole. The minimum base plate thickness for all poles is determined by the following criteria:

Case 1 Circular or rectangular solid base plate with the upright pole welded to the top surface of base plate with full penetration butt weld, where no stiffeners are provided. A base plate with a small center hole, which is less than 1/3 of the upright diameter, and located concentrically with the upright pole, may be considered as a solid base plate.

The magnitude of bending moment in the base plate, induced by the anchoring force of each anchor bolt is  $M = (P \times D_1) / 2$ , where

$M$  = bending moment at the critical section of the base plate induced by one (1) anchor bolt

$P$  = anchoring force of each anchor bolt

$D_1$  = horizontal distance between the anchor bolt center and the outer face of the upright, or the difference between the bolt circle radius and the outside radius of the upright

Locate the critical section at the face of the anchor bolt and perpendicular to the bolt circle radius. The overlapped part of two (2) adjacent critical sections is considered ineffective.

Case 2 Circular or rectangular base plate with the upright pole socketed into and attached to the base plate with two (2) lines of fillet weld, and where no stiffeners are provided, or any base plate with a center hole that is larger in diameter than 1/3 of the upright diameter.

The magnitude of bending moment induced by the anchoring force of each anchor bolt is  $M = P \times D_2$ ,

where  $P$  = anchoring force of each anchor bolt

$D_2$  = horizontal distance between the face of the upright and the face of the anchor bolt nut

Locate the critical section at the face of the anchor bolt top nut and perpendicular to the radius of the bolt circle. The overlapped part of two (2) adjacent critical sections is considered ineffective.

If the base plate thickness calculated for Case 2 is less than Case 1, use the thickness calculated for Case 1.

The following additional requirements apply concerning pole base plates.

- Ensure that whichever case governs as defined above, the anchor bolt diameter is set to match the base plate thickness. If the minimum diameter required for the anchor bolt exceeds the thickness required for the base plate, set the base plate thickness equal to the required bolt diameter.

- For all metal poles, use a full penetration groove weld with a backing ring to connect the pole upright component to the base. Refer to Metal Pole Standard Drawing Sheet M3 or M4.

The Professional Engineer is wholly responsible for the design of all poles. Review and acceptance of these designs by the Department does not relieve the said Professional Engineer of his or her responsibility.

#### **D. Strain Poles:**

Refer to Metal Pole Standard Drawing Sheets M2 and M3 for fabrication details.

Provide two (2) messenger cable (span wire) clamps and associated hardware for attachment of messenger cable. Ensure diameter of the clamp is appropriate to its location on the pole and is appropriately designed for adjustment from 1'-6" below the top, down to 6'-6" below the top of the pole. Do not attach more than one (1) support cable to a messenger cable clamp.

Provide a minimum of three (3) 2-inch holes equipped with an associated coupling and weatherhead on the messenger cable load side of the pole to accommodate passage of signal cables from inside the pole. Provide galvanized threaded plugs for all unused couplings at pole entrance points. Refer to Metal Pole Standard Drawing Sheet M3 for fabrication details.

Provide designs with a 6" x 12" hand hole with reinforcing frame for each pole.

Provide a terminal compartment with cover and screws in each pole encompassing the hand hole and containing a 12-terminal barrier type terminal block. Provide two (2) terminal screws with a removable shorting bar between them for each termination. Furnish terminal compartment covers attached to the pole by a sturdy chain or cable approved by the Engineer. Ensure chain or cable is long enough to permit cover to hang clear of the compartment opening when cover is removed and is strong enough to prevent vandalism. Ensure chain or cable will not interfere with service to cables in the pole base.

Have poles permanently stamped above the hand holes with the identification tag details as shown on Metal Pole Standard Drawing Sheets M2 and M3.

Provide grounding lug(s) in the approximate vicinity of the messenger cable clamp for bonding and grounding messenger cable. Lugs must accept #4 AWG wire to bond messenger cables to the pole in order to provide an effective ground fault circuit path. Refer to Metal Pole Standard Drawing Sheet M6 for construction details.

Install metal poles, hardware, and fittings as shown on the manufacturer's installation drawings. Ensure the installed pole, when fully loaded, is within 1 degree 40 minutes (1°40') of vertical. Install poles with the manufacturer's recommended "rake." Where required, use threaded leveling nuts to establish rake.

#### **E. Mast Arm Poles:**

Refer to Metal Pole Standard Drawing Sheets M2 through M5 for fabrication details.

Fabricate metal arm shaft from coil or plate steel that meet the requirements of ASTM A 595 Grade A tubes. Provide arm shafts of round or near round (18 sides or more) cross-section, or multi-sided tubular cross-section with no less than six sides, having a uniform linear taper of 0.14 in/ft. Construct shafts from one piece of single-ply plate or coil, eliminating circumferential weld splices.

Use the submerged arc process, or other NCDOT previously approved process suitable for arm shafts, to continuously weld arm shafts along their entire length. The longitudinal seam weld shall be finished flush to the outside contour of the base metal. Ensure arm shaft has no circumferential welds except at the lower end joining the shaft to the arm flange plate. Use full penetration groove welds with backing ring for all tube-to-transverse-plate connections in accordance with 1<sup>st</sup> Edition

AASHTO. Provide welding that conforms to Article 1072-18 of the *Standard Specifications*, except no field welding on any part of the arm shaft will be permitted unless approved by a qualified Engineer.

After fabrication, hot-dip galvanize steel arm shafts and all assembly components per Section 1076 of the *Standard Specifications*. Design arm shafts with weep holes large enough and properly located to drain molten zinc during the galvanization process. Provide hot-dip galvanizing on steel arm shafts that meets or exceeds ASTM Standard A-123, AASHTO M111, or an approved equivalent. Perform repair of damaged galvanizing that complies with the following *Standard Specifications* article:

Repair of Galvanizing .....Article 1076-7

Ensure metal arm shafts permit cables to be installed inside arm shafts. For holes in arm shafts used to accommodate cables, provide full-circumference grommets. Wire access holes for arm flange plates should be deburred, non-grommeted, and oversized to fit around 4-inch diameter grommeted wire access holes for shaft flange plates.

Provide a minimum of four (4) 1-1/2” diameter high strength bolts for connection between arm plate and pole plate. Increase number of bolts to a minimum of six (6) 1-1/2” diameter high strength bolts when arm lengths are greater than 50’-0” long.

Provide designs with a 6” x 12” hand hole with reinforcing frame for each pole.

Provide a terminal compartment with cover and screws in each pole encompassing the hand hole and containing a 12-terminal barrier type terminal block. Provide two (2) terminal screws with a removable shorting bar between them for each termination. Furnish terminal compartment covers attached to the pole by a sturdy chain or cable approved by the Engineer. Ensure chain or cable is long enough to permit cover to hang clear of the compartment opening when cover is removed and is strong enough to prevent vandalism. Ensure chain or cable will not interfere with service to cables in the pole base.

Have poles permanently stamped above the hand holes with the identification tag details as shown on Metal Pole Standard Drawing Sheets M2 and M4.

Provide a removable end cap with stainless steel attachment screws for the end of each mast arm. Ensure cap is cast aluminum conforming to Aluminum Association Alloy 356.0F. Furnish cap attached to arm with a sturdy chain or cable approved by the Engineer. Ensure chain or cable is long enough to permit cap to hang clear of arm end opening when cap is removed.

Provide pole flange plates and associated gussets and fittings for attachment of required mast arms. As part of each mast arm attachment, provide a cable passage hole in pole to allow passage of cables from pole to arm. Provide a grommeted 4-inch diameter cable passage hole on the shaft side of the connection to allow passage of cables from pole to arm.

Furnish all arm plates and necessary attachment hardware, including bolts and brackets.

Provide two (2) extra bolts for each arm.

Provide arms with weatherproof connections for attaching to the pole shaft.

Provide hardware that is galvanized steel, stainless steel, or corrosive-resistant aluminum.

Install metal poles, hardware, and fittings as shown on the manufacturer’s installation drawings. Ensure the installed pole, when fully loaded, is within 1 degree 40 minutes (1°40’) of vertical. Install poles with the manufacturer’s recommended “rake.” Where required, use threaded leveling nuts to establish rake.

Install horizontal-type arms with a manufactured rise preventing arm from deflecting below arm attachment height.

Ensure maximum angular rotation of the top of mast arm pole does not exceed 1 degree 40 minutes (1°40'). Ensure allowable mast arm deflection does not exceed that allowed per 1<sup>st</sup> Edition AASHTO. For all load combination limit states specified under Section 3 of 1<sup>st</sup> Edition AASHTO, restrict tip of fully loaded arm from going below arm attachment point with the pole.

## 5.2. DRILLED PIER FOUNDATIONS FOR METAL POLES

Analysis procedures and formulas shall be based on AASHTO 1<sup>st</sup> Edition, latest ACI-318 code and the *Drilled Shafts: Construction Procedures and Design Methods* FHWA-NHI-10-016 manual. Design methods based on engineering publications or research papers must have prior approval from NCDOT. The Department reserves the right to accept or reject any method used for the analysis.

Ensure deflection at top of foundation does not exceed 1 inch for worst-case (Service Limit State) lateral load.

Use LPILE Plus V6.0 or later for lateral analysis. Submit inputs, results and corresponding graphs with the design calculations.

Calculate skin friction using the  $\alpha$ -method for cohesive soils and the  $\beta$ -method for cohesion-less soils (**Broms method will not be accepted**). Detailed descriptions of the “ $\alpha$ ” and “ $\beta$ ” methods can be found in *FHWA-NHI-10-016*.

Omit first 2.5 feet for cohesive soils when calculating skin friction.

Assume a hammer efficiency of 0.70 unless value is provided.

All CCTV and MVD pole drilled shafts shall be a minimum of 4'-0" diameter. Refer to Standard Drawing Nos. M7 and M8.

Design custom foundations to carry maximum capacity of each metal pole. For standard case strain poles with custom design, use actual shear, axial and moment reactions from the Standard Strain Pole Foundation Selection Table shown on Standard Drawing No. M8.

When poor soil conditions are encountered, which could create an excessively large foundation design, consideration may be given to allow an exemption to the maximum capacity design. The Contractor must gain approval from the Engineer before reducing a foundation's capacity. On projects where poor soil is known to be present, the Contractor should have foundation designs approved before releasing poles for fabrication.

Have the Contractor notify the Engineer if the proposed foundation is to be installed on a slope other than 8H: 1V or flatter.

### A. Description:

Furnish and install foundations for NCDOT metal poles with all necessary hardware in accordance with the plans and specifications.

Metal Pole Standards have been developed and implemented by NCDOT for use at signalized intersections in North Carolina. If the plans call for a standard strain pole, then a standard foundation may be selected from the plans. However, the Contractor is not required to use a standard foundation. If the Contractor chooses to design a non-standard site-specific foundation for a standard strain pole or if the plans call for a non-standard site-specific pole, design the foundation to conform to the applicable provisions in the NCDOT Metal Pole Standard Drawings and Section B4 (Non-Standard Foundation Design) below. If non-standard site-specific foundations are designed for standard QPL approved strain poles, the foundation designer must use the design moment

specified by load case on Metal Pole Standard Drawing Sheet M8. Failure to conform to this requirement will be grounds for rejection of the design.

If the Contractor chooses to design a non-standard foundation for a standard strain pole and the soil test results indicate a standard foundation is feasible for the site, the Contractor will be paid the cost of the standard foundation. Any additional cost associated with a non-standard site-specific foundation including additional materials, labor and equipment will be considered incidental to the cost of the standard foundation. All costs for the non-standard foundation design will be considered incidental to the cost of the standard foundation.

**B. Soil Test and Foundation Determination:**

**1. General:**

Drilled piers are reinforced concrete sections, cast-in-place against in situ, undisturbed material. Drilled piers are of straight shaft type and vertical.

**2. Soil Test:**

Perform a soil test at each proposed metal pole location. Complete all required fill placement and excavation at each pole location to finished grade before drilling each boring. Soil tests performed that are not in compliance with this requirement may be rejected and will not be paid. Drill one boring to a depth of 26 feet within a 25-foot radius of each proposed foundation.

Perform standard penetration tests (SPT) in accordance with ASTM D 1586 at depths of 1, 2.5, 5, 7.5, 10, 15, 20 and 26 feet. Discontinue the boring if one of the following occurs:

- A total of 100 blows have been applied in any two consecutive 6-inch intervals.
- A total of 50 blows have been applied with < 3-inch penetration.

Describe each pole location along the project corridor in a manner that is easily discernible to both the Contractor’s Designer and NCDOT Reviewers. If the pole is at an intersection, label the boring the “Intersection of (Route or SR #), (Street Name) and (Route or SR #), (Street Name), \_\_\_\_\_ County, Signal or Asset Inventory No. \_\_\_\_\_”. Label borings with “B- N, S, E, W, NE, NW, SE or SW” corresponding to the quadrant location within the intersection.

If the pole location is located between intersections, provide a coordinate location and offset, or milestone number and offset. Pole numbers should be made available to the Drill Contractor. Include pole numbers in the boring label if they are available. If they are not available, ensure the boring labels can be cross-referenced to corresponding pole numbers. For each boring, submit a legible (hand-written or typed) boring log signed and sealed by a licensed Geologist or Professional Engineer registered in North Carolina. Include on each boring the SPT blow counts and N-values at each depth, depth of the boring, hammer efficiency, depth of water table and a general description of the soil types encountered using the AASHTO Classification System.

Borings that cannot be easily correlated to their specific pole location will be returned to the Contractor for clarification; or if approved by the Engineer, the foundation may be designed using the worst-case soil condition obtained as part of this project.

**3. Standard Foundation Determination:**

Use the following method for determining the Design N-value:

$$N_{AVG} = \frac{N_{@1'} + N_{@2.5'} + \dots + N_{@Deepest\ Boring\ Depth}}{Total\ Number\ of\ N\ values}$$

$$Y = (N_{@1'})^2 + (N_{@2.5'})^2 + \dots + (N_{@Deepest\ Boring\ Depth})^2$$



$$Z = N_{@1'} + N_{@2.5'} + \dots + N_{@Deepest \ Boring \ Depth}$$

$$N_{STD \ DEV} = \sqrt{\left( \frac{(Total \ Number \ of \ N \ values \times Y) - Z^2}{(Total \ Number \ of \ N \ values) \times (Total \ Number \ of \ N \ values - 1)} \right)}$$

**Design N-value** equals lesser of the following two conditions:

$$N_{AVG} - (N_{STD \ DEV} \times 0.45)$$

**OR**

$$Average \ of \ First \ Four \ (4)N \ values = \frac{N_{@1'} + N_{@2.5'} + N_{@5'} + N_{@7.5'}}{4}$$

*Note: If less than four (4) N-values are obtained because of criteria listed in Section 2 above, use average of N-values collected for second condition. Do not include the N-value at the deepest boring depth for above calculations if the boring is discontinued at or before the required boring depth because of criteria listed in Section 2 above. Use N-value of zero (0) for weight of hammer or weight of rod. If N-value is greater than fifty (50), reduce N-value to fifty (50) for calculations.*

If standard NCDOT strain poles are shown on the plans and the Contractor chooses to use standard foundations, determine a drilled pier length, “L,” for each signal pole from the Standard Strain Pole Foundations Chart (sheet M8) based on the Design N-value and the predominant soil type. For each standard pole location, submit a completed “Metal Pole Standard Foundation Selection Form” signed by the Contractor’s representative. Signature on form is for verification purposes only. Include the Design N-value calculation and resulting drilled pier length, “L,” on each form.

If non-standard site-specific poles are shown on the plans, submit completed boring logs collected in accordance with Section 2 (Soil Test) along with pole loading diagrams from the plans to the Contractor-selected pole Fabricator to assist in the pole and foundation design.

If one of the following occurs, the Standard Foundations Chart shown on the plans may not be used and a non-standard foundation may be required. In such case, contact the Engineer.

- The Design N-value is less than four (4).
- The drilled pier length, “L”, determined from the Standard Foundations Chart, is greater than the depth of the corresponding boring.

In the case where a standard foundation cannot be used, the Department will be responsible for the additional cost of the non-standard foundation.

Foundation designs are based on level ground around the traffic signal pole. If the slope around the edge of the drilled pier is steeper than 8:1 (H:V) or the proposed foundation will be less than 10 feet from the top of an embankment slope, the Contractor is responsible for providing slope information to the foundation Designer and to the Engineer so it can be considered in the design.

The “Metal Pole Standard Foundation Selection Form” may be found at:

<https://connect.ncdot.gov/resources/safety/Pages/ITS-Design-Resources.aspx>

If assistance is needed, contact the Engineer.

#### **4. Non-Standard Foundation Design:**

Design non-standard foundations based upon site-specific soil test information collected in accordance with Section 2 (Soil Test). Design drilled piers for side resistance in accordance with Section 10.8 of the *2014 AASHTO LRFD Bridge Design Specifications, 7<sup>th</sup> Edition*. Use computer software LPILE version-6.0 or later manufactured by Ensoft, Inc. to analyze drilled piers. Use computer software gINT V8i or later manufactured by Bentley Systems, Inc. with the current NCDOT gINT library and data template to produce SPT boring logs. Provide a drilled pier foundation for each pole with a length and diameter resulting in horizontal lateral movement less than 1 inch at top of the pier, and horizontal rotational movement less than 1 inch at the edge of pier. Contact the Engineer for pole loading diagrams of standard poles used for non-standard foundation designs. Submit non-standard foundation designs including drawings, calculations, and soil boring logs to the Engineer for review and approval before construction.

#### **C. Drilled Pier Construction:**

Construct drilled pier foundation and install anchor rod assemblies in accordance with the *Foundations and Anchor Rod Assemblies for Metal Poles* Standard Special Provision SP09-R005 located at:

<https://connect.ncdot.gov/resources/Specifications/Pages/2024-Specifications-and-Special-Provisions.aspx>

### **5.3. METAL POLE REMOVALS**

#### **A. Description:**

Remove and dispose of existing metal support poles, and remove and dispose of existing foundations, associated anchor bolts, electrical wires and connections.

#### **B. Construction Methods:**

##### **1. Foundations:**

Remove and promptly dispose of the metal support pole foundations including reinforcing steel, electrical wires, and anchor bolts to a minimum depth of 2 feet below the finished ground elevation. At the Contractor's option, remove the complete foundation.

##### **2. Metal Poles:**

Consult Division Traffic Services regarding ownership of poles. If the Division chooses to maintain these structures in their inventory for future use, permanently mark the pole with the signal inventory number, asset inventory number or some identifying information that identifies where the pole came from.

Remove the metal support poles, and promptly transport the metal support poles from the project. Use methods to remove the metal support poles and attached equipment that will not result in damage to other portions of the project or facility. Repair damages that are a result of the Contractor's actions at no additional cost to the Department.

Transport and properly dispose of the materials.

Backfill and compact disturbed areas to match the finished ground elevation. Seed unpaved areas.

Use methods to remove the foundations that will not result in damage to other portions of the project or facility. Repair damages that are a result of the Contractor's actions at no cost to the Department.

**5.4. POLE NUMBERING SYSTEM**

Attach an identification tag to each pole shaft section as shown on Metal Pole Standard Sheet M2 “Typical Fabrication Details for All Metal Poles.”

**5.5. MEASUREMENT AND PAYMENT**

*Metal Strain Signal Pole* will be measured and paid as the actual number of metal strain signal poles (without regard to height or load capacity) furnished, installed and accepted.

*Metal Pole with Single Mast Arm* will be measured and paid as the actual number of metal poles with single mast arms furnished, installed, and accepted.

*Metal Pole with Dual Mast Arm* will be measured and paid as the actual number of metal poles with dual mast arms furnished, installed, and accepted.

*Mast Arm with Metal Pole Design* will be measured and paid as the actual number of designs for mast arms with metal poles furnished and accepted.

*Metal Pole Foundation Removal* will be measured and paid as the actual number of metal signal pole foundations removed and disposed.

*Metal Pole Removal* will be measured and paid as the actual number of metal signal poles removed and disposed.

*Soil Test* will be measured and paid as the actual number of soil tests with SPT borings drilled furnished and accepted.

*Drilled Pier Foundation* will be measured and paid as the actual volume of concrete poured in cubic yards of drilled pier foundation furnished, installed and accepted.

No measurement will be made for foundation designs prepared with metal pole designs, as these will be considered incidental to designing Traffic Signal support structures.

Payment will be made under:

<b>Pay Item</b>	<b>Pay Unit</b>
Metal Strain Signal Pole .....	Each
Metal Pole with Single Mast Arm .....	Each
Metal Pole with Dual Mast Arm.....	Each
Mast Arm with Metal Pole Design .....	Each
Metal Pole Foundation Removal .....	Each
Metal Pole Removal.....	Each
Soil Test .....	Each
Drilled Pier Foundation.....	Cubic Yard



## 6. ETHERNET EDGE SWITCH

Furnish and install a managed Ethernet edge switch as specified below that is fully compatible, interoperable, and completely interchangeable and functional within the existing City, Division, or Statewide traffic signal system communications network.

### 6.1. DESCRIPTION

#### A. Ethernet Edge Switch:

Furnish and install a hardened, field Ethernet edge switch (hereafter “edge switch”) for the traffic signal controller or ITS device as specified below. Ensure that the edge switch provides wire-speed, fast Ethernet connectivity at transmission rates of 1000 megabits per second from each remote traffic signal controller or ITS device location to the routing switches.

Contact the City or NCDIT to arrange for the programming of the new Field Ethernet Switches with the necessary network configuration data, including but not limited to, the IP Address, Default Gateway, Subnet Mask and VLAN ID information. Provide a minimum ten (10) working days notice to allow the City or NCDIT to program the new devices.

#### B. Network Management:

Ensure that the edge switch is fully compatible with the existing City, Division, or Statewide Network Management Software.

### 6.2. MATERIALS

#### A. General:

Ensure that the edge switch is fully compatible and interoperable with the trunk Ethernet network interface and that the edge switch supports half and full duplex Ethernet communications.

Furnish an edge switch that provide 99.999% error-free operation, and that complies with the Electronic Industries Alliance (EIA) Ethernet data communication requirements using single-mode fiber-optic transmission medium and copper transmission medium. Ensure that the edge switch has a minimum mean time between failures (MTBF) of 10 years, or 87,600 hours, as calculated using the Bellcore/Telcordia SR-332 standard for reliability prediction.

#### B. Compatibility Acceptance

The Engineer has the authority to require the Contractor to submit a sample Field Ethernet Switch and SFP along with all supporting documentation, software and testing procedures to allow a compatibility acceptance test be performed prior to approving the proposed Field Ethernet Switch and Field Ethernet Transceiver for deployment. **The Compatibility Acceptance testing will ensure that the proposed device is 100% compatible and interoperable with the existing City, Division, or Statewide Signal System network, monitoring software and Traffic Operations Center network hardware.** Allow fifteen (15) working days for the Compatibility Acceptance Testing to be performed.

#### C. Standards:

Ensure that the edge switch complies with all applicable IEEE networking standards for Ethernet communications, including but not limited to:

- IEEE 802.1D standard for media access control (MAC) bridges used with the Spanning Tree Protocol (STP);
- IEEE 802.1Q standard for port-based virtual local area networks (VLANs);
- IEEE 802.1P standard for Quality of Service (QoS);

- IEEE 802.1w standard for MAC bridges used with the Rapid Spanning Tree Protocol (RSTP);
- IEEE 802.1s standard for MAC bridges used with the Multiple Spanning Tree Protocol;
- IEEE 802.1x standard for port based network access control, including RADIUS;
- IEEE 802.3 standard for local area network (LAN) and metropolitan area network (MAN) access and physical layer specifications;
- IEEE 802.3u supplement standard regarding 100 Base TX/100 Base FX;
- IEEE 802.3x standard regarding flow control with full duplex operation; and
- IFC 2236 regarding IGMP v2 compliance.
- IEEE 802.1AB Link Layer Discovery Protocol (LLDP)
- IEEE 802.3ad Ethernet Link Aggregation
- IEEE 802.3i for 10BASE-T (10 Mbit/s over Fiber-Optic)
- IEEE 802.3ab for 1000BASE-T (1Gbit/s over Ethernet)
- IEEE 802.3z for 1000BASE-X (1 Gbit/s Ethernet over Fiber-Optic)

#### **D. Functional:**

Ensure that the edge switch supports all Layer 2 management features and certain Layer 3 features related to multicast data transmission and routing. These features shall include, but not be limited to:

- An STP healing/convergence rate that meets or exceeds specifications published in the IEEE 802.1D standard.
- An RSTP healing/convergence rate that meets or exceeds specifications published in the IEEE 802.1w standard.
- An Ethernet edge switch that is a port-based VLAN and supports VLAN tagging that meets or exceeds specifications as published in the IEEE 802.1Q standard, and has a minimum 4-kilobit VLAN address table (254 simultaneous).
- A forwarding/filtering rate that is a minimum of 14,880 packets per second for 10 megabits per second and 148,800 packets per second for 100 megabits per second.
- A minimum 4-kilobit MAC address table.
- Support of Traffic Class Expediting and Dynamic Multicast Filtering.
- Support of, at a minimum, snooping of Version 2 & 3 of the Internet Group Management Protocol (IGMP).
- Support of remote and local setup and management via telnet or secure Web-based GUI and command line interfaces.
- Support of the Simple Network Management Protocol version 3 (SNMPv3). Verify that the Ethernet edge switch can be accessed using the resident EIA-232 management port, a telecommunication network, or the Trivial File Transfer Protocol (TFTP).
- Port security through controlling access by the users. Ensure that the Ethernet edge switch has the capability to generate an alarm and shut down ports when an unauthorized user accesses the network.
- Support of remote monitoring (RMON-1 & RMON-2) of the Ethernet agent.
- Support of the TFTP and SNTP. Ensure that the Ethernet edge switch supports port mirroring for troubleshooting purposes when combined with a network analyzer.

**E. Physical Features:**

*Ports:* Provide 10/100/1000 Mbps auto-negotiating ports (RJ-45) copper Fast Ethernet ports for all edge switches. Provide auto-negotiation circuitry that will automatically negotiate the highest possible data rate and duplex operation possible with attached devices supporting the IEEE 802.3 Clause 28 auto-negotiation standard.

*Optical Ports:* Ensure that all fiber-optic link ports operate at 1310 or 1550 nanometers in single mode. Provide Type LC connectors for the optical ports, as specified in the Plans or by the Engineer. Do not use mechanical transfer registered jack (MTRJ) type connectors.

Provide an edge switch having a minimum of two optical 100/1000 Base X ports capable of transmitting data at 100/1000 megabits per second. Ensure that each optical port consists of a pair of fibers; one fiber will transmit (TX) data and one fiber will receive (RX) data. Ensure that the optical ports have an optical power budget of at least 15 dB. Provide small form-factor pluggable modules (SFPs) with a maximum range that meets or exceeds the distance requirement as indicated on the Plans.

*Copper Ports:* Provide an edge switch that includes a minimum of four copper ports. Provide Type RJ-45 copper ports and that auto-negotiate speed (i.e., 10/100/1000 Base) and duplex (i.e., full or half). Ensure that all 10/100/1000 Base TX ports meet the specifications detailed in this section and are compliant with the IEEE 802.3 standard pinouts. Ensure that all Category 6 unshielded twisted pair/shielded twisted pair network cables are compliant with the EIA/TIA-568-B standard.

*Port Security:* Ensure that the edge switch supports/complies with the following (remotely) minimum requirements:

- Ability to configure static MAC addresses access;
- Ability to disable automatic address learning per ports; know hereafter as Secure Port. Secure Ports only forward; and
- Trap and alarm upon any unauthorized MAC address and shutdown for programmable duration. Port shutdown requires administrator to manually reset the port before communications are allowed.

**F. Management Capabilities:**

Ensure that the edge switch supports all Layer 2 management features and certain Layer 3 features related to multicast data transmission and routing. These features shall include, but not be limited to:

- An STP healing/convergence rate that meets or exceeds specifications published in the IEEE 802.1 D standards;
- An RSTP healing/convergence rate that meets or exceeds specifications published in the IEEE 802.1w standard;
- An Ethernet edge switch that is a port-based VLAN and supports VLAN tagging that meets or exceeds specifications as published in the IEEE 802.1Q standard, and has a minimum 4-kilobit VLAN address table (254 simultaneous);
- A forwarding/filtering rate that is a minimum of 14,880 packets per second for 10 megabits per second, 148,800 packets per second for 100 megabits per second and 1,488,000 packets per second for 1000 megabits per second;
- A minimum 4-kilobit MAC address table;
- Support of Traffic Class Expediting and Dynamic Multicast Filtering.

- Support of, at a minimum, snooping of Version 2 & 3 of the Internet Group Management Protocol (IGMP);
- Support of remote and local setup and management via telnet or secure Web-based GUI and command line interfaces; and
- Support of the Simple Network Management Protocol (SNMP). Verify that the Ethernet edge switch can be accessed using the resident EIA-232 management port, a telecommunication network, or the Trivial File Transfer Protocol (TFTP).

*Network Capabilities:* Provide an edge switch that supports/complies with the following minimum requirements:

- Provide full implementation of IGMPv2 snooping (RFC 2236);
- Provide full implementation of SNMPv1, SNMPv2c, and/or SNMPv3;
- Provide support for the following RMON–I groups, at a minimum:
  - Part 1: Statistics
  - Part 2: History
  - Part 3: Alarm
  - Part 9: Event
- Provide support for the following RMON–2 groups, at a minimum:
  - Part 13: Address Map
  - Part 16: Layer Host
  - Part 17: Layer Matrix
  - Part 18: User History
- Capable of mirroring any port to any other port within the switch;
- Meet the IEEE 802.1Q (VLAN) standard per port for up to four VLANs;
- Meet the IEEE 802.3ad (Port Trunking) standard for a minimum of two groups of four ports;
- Password manageable;
- Telnet/CLI;
- HTTP (Embedded Web Server) with Secure Sockets Layer (SSL); and
- Full implementation of RFC 783 (TFTP) to allow remote firmware upgrades.

*Network Security:* Provide an edge switch that supports/complies with the following (remotely) minimum network security requirements:

- Multi-level user passwords;
- RADIUS centralized password management (IEEE 802.1X);
- SNMPv3 encrypted authentication and access security;
- Port security through controlling access by the users: ensure that the Ethernet edge switch has the capability to generate an alarm and shut down ports when an unauthorized user accesses the network;
- Support of remote monitoring (RMON-1&2) of the Ethernet agent; and
- Support of the TFTP and Sntp. Ensure that the Ethernet edge switch supports port mirroring for troubleshooting purposes when combined with a network analyzer.

### **G. Electrical Specifications:**

Ensure that the edge switch operates and power is supplied with 115 volts of alternating current (VAC). Ensure that the edge switch has a minimum operating input of 110 VAC and a maximum operating input of 130 VAC. Ensure that if the device requires operating voltages other than 120 VAC, supply the required voltage converter. Ensure that the maximum power consumption does not

exceed 50 watts. Ensure that the edge switch has diagnostic light emitting diodes (LEDs), including link, TX, RX, speed (for Category 6 ports only), and power LEDs.

#### H. Environmental Specifications:

Ensure that the edge switch performs all of the required functions during and after being subjected to an ambient operating temperature range of -30 degrees to 165 degrees Fahrenheit as defined in the environmental requirements section of the NEMA TS 2 standard, with a noncondensing humidity of 0 to 95%.

Provide certification that the device has successfully completed environmental testing as defined in the environmental requirements section of the NEMA TS 2 standard. Provide certification that the device meets the vibration and shock resistance requirements of Sections 2.1.9 and 2.1.10, respectively, of the NEMA TS 2 standard. Ensure that the edge switch is protected from rain, dust, corrosive elements, and typical conditions found in a roadside environment.

The edge switch shall meet or exceed the following environmental standards:

- IEEE 1613 (electric utility substations)
- IEC 61850-3 (electric utility substations)
- IEEE 61800-3 (variable speed drive systems)
- IEC 61000-6-2 (generic industrial)
- EMF – FCC Part 15 CISPR (EN5502) Class A

#### I. Ethernet Patch Cable:

Furnish a factory pre-terminated/pre-connectorized Ethernet patch cable with each edge switch. Furnish Ethernet patch cables meeting the following physical requirements:

- Five (5)-foot length
- Category 6 or better
- Factory-installed RJ-45 connectors on both ends
- Molded anti-snag hoods over connectors
- Gold plated connectors
- Copper-clad aluminum is **NOT** allowed.

Furnish Fast Ethernet patch cords meeting the following minimum performance requirements:

- TIA/EIA-568-B-5, Additional Transmission Performance Specifications for 4-pair 100  $\Omega$  Enhanced Category 6 Cabling
- Frequency Range: 1-100 MHz
- Near-End Crosstalk (NEXT): 30.1 dB
- Power-sum NEXT: 27.1 dB
- Attenuation to Crosstalk Ratio (ACR): 6.1 dB
- Power-sum ACR: 3.1 dB
- Return Loss: 10dB
- Propagation Delay: 548 nsec

**6.3. CONSTRUCTION METHODS**

**A. General:**

Ensure that the edge switch is UL listed.

Verify that network/field/data patch cords meet all ANSI/EIA/TIA requirements for Category 6 four-pair unshielded twisted pair cabling with stranded conductors and RJ45 connectors.

Contact the City, Division, or NCDIT a minimum of 10 working days prior to installation to allow for the programming of the edge switch.

**B. Edge Switch:**

Mount the edge switch inside each field cabinet by securely fastening the edge switch to the upper end of the right rear vertical rail of the equipment rack using manufacturer-recommended or Engineer-approved attachment methods, attachment hardware and fasteners.

Ensure that the edge switch is mounted securely in the cabinet and is fully accessible by field technicians without blocking access to other equipment. Verify that fiber-optic jumpers consist of a length of cable that has connectors on both ends, primarily used for interconnecting termination or patching facilities and/or equipment.

**6.4. MEASUREMENT AND PAYMENT**

*Ethernet Edge Switch* will be measured and paid as the actual number of Ethernet edge switches furnished, installed, and accepted.

No separate measurement will be made for Ethernet patch cable, small form factor pluggable modules (SFPs), power cord, mounting hardware, nuts, bolts, brackets, or edge switch programming as these will be considered incidental to furnishing and installing the edge switch.

Payment will be made under:

<b>Pay Item</b>	<b>Pay Unit</b>
Ethernet Edge Switch.....	Each

**7. DIGITAL CCTV CAMERA ASSEMBLY**

**7.1. DESCRIPTION**

Furnish and install a Digital CCTV Camera Assembly as described in these Project Special Provisions. All new CCTV cameras shall be fully compatible with the video management software currently in use by the City of Wilmington. Provide a Pelco Spectra Enhanced low light 30X minimum zoom, Axis Dome Network Camera low light 30X minimum zoom or an approved equivalent that meets the requirements of these Project Special Provisions.

**7.2. MATERIALS**

**A. General**

Furnish and install new CCTV camera assembly at the locations shown on the Plans and as approved by the Engineer. Each assembly consists of the following:

- One dome CCTV color digital signal processing camera unit with zoom lens, filter, control circuit, and accessories in a single enclosed unit



- A NEMA-rated enclosure constructed of aluminum with a clear acrylic dome or approved equal Camera Unit housing.
- Motorized pan, tilt, and zoom
- Built-in video encoder capable of H.264/MPEG-4 compression for video-over IP transmission
- Pole-mount camera attachment assembly
- A lightning arrestor installed in-line between the CCTV camera and the equipment cabinet components.
- All necessary cable, connectors and incidental hardware to make a complete and operable system.

## **B. Camera and Lens**

### **1. Cameras**

Furnish a new CCTV camera that utilizes charged-coupled device (CCD) technology or Complementary Metal-Oxide-Semiconductor (CMOS) technology. The camera must meet the following minimum requirements:

- Video Resolution: Minimum 1920x1080 (HDTV 1080p)
- Aspect Ratio: 16:9
- Overexposure protection: The camera shall have built-in circuitry or a protection device to prevent any damage to the camera when pointed at strong light sources, including the sun
- Low light condition imaging
- Wide Dynamic Range (WDR) operation
- Electronic Image Stabilization (EIS)
- Automatic focus with manual override

### **2. Zoom Lens**

Furnish each camera with a motorized zoom lens that is a high-performance integrated dome system or approved equivalent with automatic iris control with manual override and neutral density spot filter. Furnish lenses that meet the following optical specifications:

- 30X minimum optical zoom, and 12X minimum digital zoom
- Preset positioning: minimum of 128 presets

The lens must be capable of both automatic and remote manual control iris and focus override operation. The lens must be equipped for remote control of zoom and focus, including automatic movement to any of the preset zoom and focus positions. Mechanical or electrical means must be provided to protect the motors from overrunning in extreme positions. The operating voltages of the lens must be compatible with the outputs of the camera control.

### **3. Communication Standards:**

The CCTV camera shall support the appropriate NTCIP 1205 communication protocol (version 1.08 or higher), ONVIF Profile G protocol, or approved equal.

#### 4. Networking Standards:

- Network Connection: Minimum 10/100 Mbps auto-negotiate
- Frame Rate: 30 to 60 fps
- Data Rate: scalable
- Built-in Web Server
- Unicast & multicast support
- Two simultaneous video streams (Dual H.264 and MJPEG):
  - Video 1: H.264 (Main Profile, at minimum)
  - Video 2: H.264 or MJPEG
- Supported Protocols: DNS, IGMPv2, NTP, RTSP, RTP, TCP, UDP, DHCP, HTTP, IPv4, IP6
- 130 db Wide Dynamic Range (WDR)

The video camera shall allow for the simultaneous encoding and transmission of the two digital video streams, one in H.264 format (high-resolution) and one in H.264 or MJPEG format (low- resolution).

Initially use UDP/IP for video transport and TCP/IP for camera control transport unless otherwise approved by the Engineer.

The 10/100BaseTX port shall support half-duplex or full-duplex and provide auto negotiation and shall be initially configured for full-duplex.

The camera unit shall be remotely manageable using standard network applications via web browser interface administration. Telnet or SNMP monitors shall be provided.

#### C. Camera Housing

Furnish new dome style enclosure for the CCTV assembly. Equip each housing with mounting assembly for attachment to the CCTV camera pole. The enclosures must be equipped with a sunshield and be fabricated from corrosion resistant aluminum and finished in a neutral color of weather resistant enamel. The enclosure must meet or exceed NEMA 4X ratings. The viewing area of the enclosure must be tempered glass. The pendant must meet NEMA Type 4X, IP66 rating and use 1-1/2-inch NPT thread. The sustained operating temperature must be -50 to 60C (-58 to 144F), condensing temperature 10 to 100% Relative Humidity (RH).

#### D. Pan and Tilt Unit

Equip each new dome style assembly with a pan and tilt unit. The pan and tilt unit must be integral to the high-performance integrated dome system. The pan and tilt unit must be rated for outdoor operation, provide dynamic braking for instantaneous stopping, prevent drift, and have minimum backlash. The pan and tilt units must meet or exceed the following specifications:

- Pan: continuous 360 Degrees rotation
- Tilt: up/down +2 to -90 degrees minimum
- Motors: Two-phase induction type, continuous duty, instantaneous reversing
- Preset Positioning: minimum of 128 presets
- Low latency for improved Pan and Tilt Control
- FCC, Class A; UL/cUL Listed



### **E. Video Ethernet Encoder**

Furnish cameras with a built-in digital video Ethernet encoder to allow video-over-IP transmission. The encoder units must be built into the camera housing and require no additional equipment to transmit encoded video over IP networks.

Encoders must have the following minimum features:

- Network Interface: Ethernet 10/100Base-TX (RJ-45 connector)
- Protocols: IPv4, IPv6, HTTP, UPnP, DNS, NTP, RTP, RTSP, TCP, UDP, IGMP, and DHCP
- Security: SSL, SSH, 802.1x, HTTPS encryption with password-controlled browser interface
- Video Streams: Minimum 2 simultaneous streams, user configurable
- Compression: H.264 (MPEG-4 Part 10/AVC)
- Resolution Scalable: NTSC-compatible 320x176 to 1920x1080 (HDTV 1080p)
- Aspect Ratio: 16:9
- Frame Rate: 1-30 FPS programmable (full motion)
- Bandwidth: 30 kbps – 6 Mbps, configurable depending on resolution
- Edge Storage: SD/SDHC/SDXC slot supporting up to 64GB memory card

### **F. Control Receiver/Driver**

Provide each new camera unit with a control receiver/driver that is integral to the CCTV dome assembly. The control receiver/driver will receive serial asynchronous data initiated from a camera control unit, decode the command data, perform error checking, and drive the pan/tilt unit, camera controls, and motorized lens. As a minimum, the control receiver/drivers must provide the following functions:

- Zoom in/out
- Automatic focus with manual override
- Tilt up/down
- Automatic iris with manual override
- Pan right/left
- Minimum 128 preset positions for pan, tilt, and zoom, 16 Preset Tours, 256 Dome Presets
- Up to 32 Window Blanks.

In addition, each control receiver/driver must accept status information from the pan/tilt unit and motorized lens for preset positioning of those components. The control receiver/driver will relay pan, tilt, zoom, and focus positions from the field to the remote camera control unit. The control receiver/driver must accept “goto” preset commands from the camera control unit, decode the command data, perform error checking, and drive the pan/tilt and motorized zoom lens to the correct preset position. The preset commands from the camera control unit will consist of unique values for the desired pan, tilt, zoom, and focus positions.

### **G. Electrical**

The camera assembly shall support Power-over-Ethernet (PoE) in compliance with IEEE 802.3. Provide any external power injector that is required for PoE with each CCTV assembly.

**H. CCTV Camera Attachment to Pole**

Furnish and install an attachment assembly for the CCTV camera unit. Use stainless steel banding approved by the Engineer.

Furnish CCTV attachments that allow for the removal and replacement of the CCTV enclosure as well as providing a weatherproof, weather tight, seal that does not allow moisture to enter the enclosure.

Furnish a CCTV Camera Attachment Assembly that can withstand wind loading at the maximum wind speed and gust factor called for in these Special Provisions and can support a minimum camera unit dead load of 45 pounds (20.4 kg).

**I. Riser**

Furnish material meeting the requirements of Section 1091-3 and 1098-5 of the 2024 Standard Specifications for Roads and Structures. Furnish a 1” riser with weatherhead for instances where the riser is only carrying an Ethernet cable. For installations where fiber optic cable is routed to the cabinet through a 2” riser with heat shrink tubing the Contractor may elect to install the Ethernet cable in the same riser with the fiber cable.

**J. Data line Surge Suppression**

Furnish data line surge protection devices (SPD) shall meet the following minimum requirements:

- UL497B
- Service Voltage: < 60 V
- Protection Modes: L-G (All), L-L (All)
- Response Time: <5 nanoseconds
- Port Type: Shielded RJ-45 IN/Out
- Clamping Level: 75 V
- Surge Current Rating: 20 kA/Pair
- Power Handling: 144 Watts
- Data Rate: up to 10 GbE
- Operating Temperature: -40° F to + 158° F
- Standards Compliance: Cat-5e, EIA/TIA 568A and EIA/TIA 568B
- Warranty: Minimum of 5-year limited warranty

The data line surge protector shall be designed to operate with Power Over Ethernet (POE) devices. The SPD shall be designed such that when used with shielded cabling, a separate earth ground is not required. It shall be compatible with Cat-5e, Cat 6, and Cat-6A cabling.

Protect the electrical and Ethernet cables from the CCTV unit entering the equipment cabinet with surge protection. Provide an integrated unit that accepts unprotected electrical and Ethernet connections and outputs protected electrical and Ethernet connections.

**K. POE Injector**

Furnish POE Injectors meeting the following minimum performance requirements and that is compatible with the CCTV Camera and Ethernet Switch provided for the project.

- Working temp/humidity: 14° F to 131° F/maximum 90%, non-condensing

- Connectors: Shielded RJ-45, EIA 568A and EIA 568B
- Input Power: 100 to 240 VAC, 50 to 60 Hz
- Pass Through Data Rates: 10/100/1000 Mbps
- Regulatory: IEEE 802.3at (POE)
- Number of Ports: 1 In and 1 Out
- Safety Approvals: UL Listed

Ensure the POE Injector is designed for Plug-and-Play installation, requiring no configurations and supports automatic detection and protection of non-standard Ethernet Terminal configurations.

### 7.3. CONSTRUCTION METHODS

#### A. General

Obtain approval of the camera locations and orientation from the Engineer prior to installing the CCTV camera assembly.

Mount CCTV camera units at a height to adequately see traffic in all directions and as approved by the Engineer. The maximum attachment height is 45 feet above ground level unless specified elsewhere or directed by the Engineer.

Mount the CCTV camera units such that a minimum 5 feet of clearance is maintained between the camera and the top of the pole to ensure adequate lightning protection is provided by the air terminal.

Mount CCTV cameras on the side of poles nearest intended field of view. Avoid occluding the view with the pole.

Install the data line surge protection device and POE Injector in accordance with the manufacturer's recommendations.

Install the riser in accordance with Section 1722 of the 2024 *Standard Specifications for Roads and Structures*. Install the Ethernet cable in the riser from the field cabinet to the CCTV camera.

#### B. Electrical and Mechanical Requirements

Install an "Air Terminal and Lightning Protections System" in accordance with the Air Terminal and Lightning Protection System Project Special Provisions for the CCTV Camera Assembly. Ground all equipment as called for in the Standard Specifications, these Special Provisions, and the Plans. **Do not install lightning protection when installing a CCTV camera assembly on a signal pole.**

Install surge protectors on all ungrounded conductors entering the CCTV enclosure.

#### C. General Test Procedure

Test the CCTV Camera and its components in a series of functional tests and ensure the results of each test meet the specified requirements. These tests should not damage the equipment. The Engineer will reject equipment that fails to fulfill the requirements of any test. Resubmit rejected equipment after correcting non-conformities and re-testing; completely document all diagnoses and corrective actions. Modify all equipment furnished under this contract, without additional cost to the Department, to incorporate all design changes necessary to pass the required tests.

Provide 4 copies of all test procedures and requirements to the Engineer for review and approval at least 30 days prior to the testing start date.

Only use approved procedures for the tests. Include the following in the test procedures:

- A step-by-step outline of the test sequence that demonstrates the testing of every function of the equipment or system tested
- A description of the expected nominal operation, output, and test results, and the pass / fail criteria
- An estimate of the test duration and a proposed test schedule
- A data form to record all data and quantitative results obtained during the test
- A description of any special equipment, setup, manpower, or conditions required by the test

Provide all necessary test equipment and technical support. Use test equipment calibrated to National Institute of Standards and Technology (NIST) standards. Provide calibration documentation upon request.

Conform to these testing requirements and the requirements of these specifications. It is the Contractor's responsibility to ensure the system functions properly even after the Engineer accepts the CCTV test results.

Provide 4 copies of the quantitative test results and data forms containing all data taken, highlighting any non-conforming results and remedies taken, to the Engineer for approval. An authorized representative of the manufacturer must sign the test results and data forms.

#### **A. Compatibility Tests**

##### **1. CCTV System**

Compatibility Tests are applicable to CCTV cameras that the Contractor wishes to furnish but are of a different manufacturer or model series than the existing units installed in the Region. If required, the Compatibility Test shall be completed and accepted by the Engineer prior to approval of the material submittal.

The Compatibility Test shall be performed in a laboratory environment at a facility chosen by the Engineer based on the type of unit being tested. Provide notice to the Engineer with the material submitted that a Compatibility Test is requested. The notice shall include a detailed test plan that will show compatibility with existing equipment. The notice shall be given a minimum of 15 calendar days prior to the beginning of the Compatibility Test.

The Contractor shall provide, install, and integrate a full-functioning unit to be tested. The Department will provide access to existing equipment to facilitate these testing procedures. The Engineer will determine if the Compatibility Test was acceptable for each proposed device. To prove compatibility the Contractor is responsible for configuring the proposed equipment at the applicable Traffic Operations Center (TOC) with the accompaniment of an approved TOC employee.

#### **B. Operational Field Test (On-Site Commissioning)**

##### **1. CCTV System**

Final CCTV locations must be field verified and approved by the Engineer. Perform the following local operational field tests at the camera assembly field site in accordance with the test plans and in the presence of the Engineer. The Contractor is responsible for providing a laptop for camera control and positioning during the test. After completing the installation of the camera

assemblies, including the camera hardware, power supply, and connecting cables, the contractor shall:

### **C. Local Field Testing**

Furnish all equipment and labor necessary to test the installed camera and perform the following tests before any connections are made.

- Verify that physical construction has been completed.
- Inspect the quality and tightness of ground and surge protector connections.
- Check the power supply voltages and outputs, check connection of devices to power source.
- Verify installation of specified cables and connection between the camera, PTZ, camera control receiver, and control cabinet.
- Make sure cabinet wiring is neat and labeled properly; check wiring for any wear and tear; check for exposed or loose wires.
- Perform the CCTV assembly manufacturer's initial power-on test in accordance with the manufacturer's recommendation.
- Set the camera control address.
- Exercise the pan, tilt, zoom, and focus operations along with preset positioning, and power on/off functions.
- Demonstrate the pan, tilt and zoom speeds and movement operation meet all applicable standards, specifications, and requirements.
- Define, test and/or change presets.
- Ensure camera field of view is adjusted properly and there are no objects obstructing the view.
- Ensure camera lens is dust-free.
- Ensure risers are bonded and conduits entering cabinets are sealed properly.
- Lightning arrestor bonded correctly.

### **D. Central Operations Testing**

- Interconnect the CCTV Camera's communication interface device with one of the following methods as depicted on the plans:
  - communication network's assigned Ethernet switch and assigned fiber-optic trunk cable and verify a transmit/receive LED is functioning and that the CCTV camera is fully operational at the TOC.

OR

  - to the DOT furnished cellular modem and verify a transmit/receive LED is functioning and that the CCTV camera is fully operational at the TOC.
- Exercise the pan, tilt, zoom, and focus operations along with preset positioning, and power on/off functions.
- Demonstrate the pan, tilt and zoom speeds and movement operation meet all applicable standards, specifications, and requirements.
- Define, test and/or change presets.

Approval of Operational Field Test results does not relieve the Contractor to conform to the requirements in these Project Special Provisions. If the CCTV system does not pass these tests, document a correction or substitute a new unit as approved by the Engineer. Re-test the system until it passes all requirements.

**7.4. MEASUREMENT AND PAYMENT**

*Digital CCTV Camera Assembly* will be measured and paid as the actual number of digital CCTV assemblies furnished, installed, integrated, and accepted. No separate measurement will be made for electrical cabling, connectors, CCTV camera attachment assemblies, conduit, condulets, risers, grounding equipment, surge protectors, PoE Injectors, PoE Cable, Air Terminal and Lightning Protection System, compatibility testing, operational testing or any other equipment or labor required to install the digital CCTV assembly.

Payment will be made under:

<b>Pay Item</b>	<b>Pay Unit</b>
Digital CCTV Camera Assembly .....	Each

**8. CCTV FIELD EQUIPMENT CABINET**

**8.1. DESCRIPTION**

For standalone CCTV Camera installations, furnish pole mounted cabinets and all necessary hardware in accordance with the plans and specifications to house CCTV control and transmission equipment.

**8.2. MATERIALS**

**A. CCTV Cabinet**

Furnish Type 336S style or equivalent pole-mounted cabinet meeting the following minimum requirements:

- Single doors on both front and rear of cabinet;
- Grounding bus bar;
- 19-inch rack system for mounting of all devices in the cabinet;
- Pull-out shelf drawer for laptop and maintenance use;
- Maintenance access connections;
- LED lighting;
- Ventilation fans;
- 120VAC power supply;
- 120VAC ground fault circuit interrupter (GFCI)-protected duplex outlets for tools;
- 120VAC surge-protected duplex outlets for equipment.
- Lightning and surge protection on incoming and outgoing electrical lines (power and data);
- UPS with sufficient capacity to hold hub’s electrical load for 4 hours.
- Managed Ethernet Edge switch if called for in the plans (paid separately);



- Fiber-optic interconnect centers if called for in the plans (paid separately)

Furnish terminal blocks for power for cabinet CCTV and communications devices as needed to accommodate the number of devices in the cabinet.

Furnish all conduits, shelving, mounting adapters, and other equipment as necessary to route cabling, mount equipment and terminate conduit in the equipment cabinet.

### **B. Shelf Drawer**

Provide a pull out, hinged-top drawer, having sliding tracks, with lockout and quick disconnect feature, such as a Vent-Rak Retractable Writing Shelf, #D-4090-13 or equivalent in the equipment cabinet. Furnish a pullout drawer that extends a minimum of 14 inches that is capable of being lifted to gain access to the interior of the drawer. Minimum interior dimensions of the drawer are to be 1 inch high, 13 inches deep, and 16 inches wide. Provide drawers capable of supporting a 40-pound device or component when fully extended.

### **C. Cabinet Light**

Each cabinet must include two (2) LED lighting fixtures (one front, one back) mounted horizontally inside the top portion of the cabinet. The fixtures must include a cool white lamp and must be operated by normal power factor UL-listed ballast. A door-actuated switch must be installed to turn on the applicable cabinet light when the front door or back door is opened. The lights must be mounted not to interfere with the upper door stay.

### **D. Surge Protection for System Equipment**

Each cabinet must be provided with devices to protect the CCTV and communications equipment from electrical surges and over voltages as described below.

#### **1. Main AC Power Input**

Each cabinet must be provided with a hybrid-type, power line surge protection device mounted inside the power distribution assembly. The protector must be installed between the applied line voltage and earth ground. The surge protector must be capable of reducing the effect of lighting transient voltages applied to the AC line. The protector must be mounted inside the Power Distribution Assembly housing facing the rear of the cabinet. The protector must include the following features and functions:

- Maximum AC line voltage: 140 VAC.
- Twenty pulses of peak current, each of which must rise in 8 microseconds and fall in 20 microseconds to ½ the peak: 20000 Amperes.
- The protector must be provided with the following terminals:
  - Main Line (AC Line first stage terminal).
  - Main Neutral (AC Neutral input terminal).
  - Equipment Line Out (AC line second state output terminal, 19 amps).
  - Equipment Neutral Out (Neutral terminal to protected equipment).
  - GND (Earth connection).
- The Main AC line in and the Equipment Line out terminals must be separated by a 200 Microhenry (minimum) inductor rated to handle 10 AMP AC Service.
- The first stage clamp must be between Main Line and Ground terminals.
- The second stage clamp must be between Equipment Line Out and Equipment Neutral.

- The protector for the first and second stage clamp must have an MOV or similar solid state device rated at 20 KA and must be of a completely solid-state design (i.e., no gas discharge tubes allowed).
- The Main Neutral and Equipment Neutral Out must be connected together internally and must have an MOV similar solid-state device or gas discharge tube rated at 20 KA between Main Neutral and Ground terminals.
- Peak Clamp Voltage: 350 volts at 20 KA. (Voltage measured between Equipment Line Out and Equipment Neutral Out terminals. Current applied between Main Line and Ground Terminals with Ground and Main Neutral terminals externally tied together).
- Voltage must never exceed 350 volts.
- The Protector must be epoxy-encapsulated in a flame-retardant material.
- Continuous service current: 10 Amps at 120 VAC RMS.
- The Equipment Line Out must provide power to cabinet CCTV and communications equipment.

**2. Ground Bus**

Provide a neutral bus that is not connected to the earth ground or the logic ground anywhere within the cabinet. Ensure that the earth ground bus and the neutral ground bus each have ten compression type terminals, each of which can accommodate wires ranging from number 14 through number 4 AWG.

**3. Uninterruptible Power Supply (UPS)**

Furnish UPS with external temperature monitoring that will shut off when running on battery power and the maximum operating temperature for the ethernet switch is reached.

Install UPS with RJ-45 ethernet network monitoring ports that can be disabled via the UPS software/firmware.

Contractor is responsible for supplying a UPS and batteries that can adequately power the cabinet load plus an additional 20% for a minimum of 4 hours. Contractor shall request the power requirements for any department supplied equipment prior to submitting UPS for approval. Allow eight (8) weeks for the department to supply equipment power requirements. Provide to the Engineer for Approval, a submittal package with Engineering Calculations consisting of, as a minimum, schematic drawing, technical data sheets, and supporting documentation. Ensure the documentation demonstrates, in theory, that the battery(ies) will provide for continuous operation for a minimum of four (4) consecutive hours with no additional charging.

Furnish and install one rack mounted UPS in each new cabinet that meet the following minimum specifications:

**Output**

Nominal Output Voltage	120V
Output Voltage Distortion	Less than 5% at full load
Output Frequency (sync to mains)	57 - 63 Hz for 60 Hz nominal
Crest Factor	up to 5:1
Waveform Type	Sine wave



**U-6202****TS-60****New Hanover County**

Output Connections

(4) NEMA 5-15R

**Input**

Nominal Input Voltage

120V

Input Frequency

50/60 Hz +/- 3 Hz (auto sensing)

Input Connections

NEMA 5-15P

Input voltage range for main operations

82 - 144V

Input voltage adjustable range for mains operation

75 -154 V

**Battery Type**

Maintenance-free sealed Lead-Acid battery with suspended electrolyte, leak-proof.

Typical recharge time

2 hours

**Communications & Management**

Interface Port(s)

DB-9 RS-232, USB,RJ-45 Ethernet

Control panel

LED status display with load and battery bar-graphs

**Surge Protection and Filtering**

Surge energy rating

480 Joules

**Environmental**

Operating Environment

-32 - 165 °F

Operating Relative Humidity

0 - 95%

**Conformance**

Regulatory Approvals

FCC Part 15 Class A, UL 1778

**8.3. CONSTRUCTION METHODS****A. General**

For each field equipment cabinet installation, use stainless steel banding or other methods approved by the Engineer to fasten the cabinet to the pole. Install field equipment cabinets so that the height to the middle of the enclosure is 4 feet from ground level. No risers shall enter the top or sides of the equipment cabinet.

Install all conduits, condulets, and attachments to equipment cabinets in a manner that preserves the minimum bending radius of cables and creates waterproof connections and seals.

Install a UPS in each cabinet and power all CCTV and communications equipment from the UPS.

**8.4. MEASUREMENT AND PAYMENT**

*Field equipment cabinet* will be measured and paid as the actual number of CCTV equipment cabinets furnished, installed and accepted.

**U-6202**

**TS-61**

**New Hanover County**

No payment will be made for the UPS, cabling, connectors, cabinet attachment assemblies, conduit, condulets, risers, grounding equipment, surge protectors, or any other equipment or labor required to install the field equipment cabinet and integrate the cabinets with the CCTV equipment.

Payment will be made under:

<b>Pay Item</b>	<b>Pay Unit</b>
Field Equipment Cabinet .....	Each

**9. CCTV WOOD POLE**

**9.1. DESCRIPTION**

Furnish and install wood poles, grounding systems and all necessary hardware for CCTV camera installations. Reference applicable Sections of Article 1720 of the 2024 *Standard Specifications for Roads and Structures for Materials and Construction*.

Furnish an air terminal and lightning protection system in accordance with the “Air Terminal & Lightning Protection System” Project Special Provisions.

Furnish and install wood poles with grounding systems and all necessary hardware in accordance with Section 1720 of the 2024 *Standard Specifications for Roads and Structures*.

**9.2. MATERIALS**

Material, equipment, and hardware furnished under this section shall be pre-approved on the Department’s QPL. For Wood poles refer to Sub articles 1082-3(F) Treated Timber and Lumber – Poles and 1082-4(A) – General; 1082-4 (B) – Timber Preservatives; 1082-4(G) – Poles; in the 2024 *Standard Specifications for Roads and Structures*.

**9.3. CCTV WOOD POLE**

Unless otherwise specified in the Plans, furnish Class 3 or better wood poles that are a minimum of 60’ long to permit the CCTV camera to be mounted approximately 45 feet above the ground and a minimum 5 feet from the top of the pole.

**9.4. CONSTRUCTION METHODS**

Mark final pole locations and receive approval from the Engineer before installing poles. Comply with all requirements of Section 1720-3 of the 2024 *Standard Specifications for Roads and Structures*.

Install the required Air Terminal & Lightning Protection System as described in the Air Terminal & Lightning Protection Specifications and as referenced in the following Typical Details:

- CCTV Camera Installation for Wood Pole with Aerial Electrical Service
- CCTV Camera Installation for Wood Pole with Underground Electrical Service

**9.5. MEASUREMENT AND PAYMENT**

*CCTV Wood Pole* will be measured and paid as the actual number of wood poles for CCTV camera furnished, installed and accepted.

No measurement will be made for equipment, labor and materials, to install the wood pole as these items of work will be incidental to furnishing and installing CCTV wood poles.

**U-6202**

**TS-62**

**New Hanover County**

No measurement will be made for furnishing and installing the “Air Terminal and Lightning Protection System” as this will be considered incidental to the “CCTV Wood Pole” installation.

Payment will be made under:

<b>Pay Item</b>	<b>Pay Unit</b>
CCTV Wood Pole .....	Each

**10. AIR TERMINAL & LIGHTNING PROTECTION SYSTEM**

**10.1. DESCRIPTION**

Furnish an air terminal and lightning protection system that is comprised of items meeting UL 96 and UL 467 product standards for lightning protection and installed to be compliant with the National Fire Protection Association 780 Standards for Lightning Protection Systems. The lightning protection system shall consist of, as a minimum, an Air Terminal, vertical Air Terminal Base (wood pole) or Air Terminal Rod Clamps (metal pole), 28-Strand bare-copper lightning conductor, 4-point grounding systems (grounding electrodes), #4 AWG copper bonding conductors, marker tape and other miscellaneous hardware.

**10.2. MATERIALS**

**A. General**

Reference the following Typical Details where applicable:

- CCTV Camera Installation for Metal Pole with Aerial Electrical Service
- CCTV Camera Installation for Metal Pole with Underground Electrical Service
- CCTV Camera Installation for Wood Pole with Aerial Electrical Service
- CCTV Camera Installation for Wood Pole with Underground Electrical Service

**B. Wood Pole**

Furnish a UL Listed Class II, copper clad minimum 48” long by ½” diameter air terminal. Ensure the air terminal has a tapered tip with a rounded point on one end and is threaded on the connection end with standard Unified Coarse (UNC) 13 threads per inch.

Furnish a copper vertical air terminal base that has internal threading to accept a ½” diameter air terminal with UNC 13 threads per inch. Provide a base that allows for a minimum ¼” mounting hole to secure the base to the vertical side of a wood pole. Ensure the air terminal base includes (2) 5/16” cap screws to secure the bare copper lightning conductor. Additionally, provide (2) ½” copper tube straps (conduit clamps) to secure the air terminal and bare copper lightning conductor to the pole.

**C. Copper Lightning Conductor and Ground Rods**

Furnish a Class II rated copper lightning conductor which consists of 28 strands (minimum) of 15 AWG copper wires to form a rope-lay bare copper lightning conductor. Furnish 5/8” diameter, 10-foot-long copper-clad steel ground rods with a 10-mil thick copper cladding to serve as an integral part of the 4-point grounding system. Furnish irreversible mechanical clamps to secure the 28-strand lightning conductor, #4 AWG bare copper ground wires and grounding electrodes together to complete the grounding system.

### 10.3. CONSTRUCTION METHODS

#### A. Wood Pole

Install the vertical air terminal base approximately 12” below the top of the wood pole and install the air terminal to the threaded connection on the base. Install a ½” copper tube strap (conduit clamp) over the air terminal, 6” from the top of the pole. Additionally, secure the copper lightning conductor under both 5/16” diameter cap screws located on the base. Install an additional ½” copper tube strap (conduit clamp) over the bare copper lightning conductor, 6” below the air terminal base. Locate the ¼” mounting hole on the vertical air terminal base and install a ¼” by 3” (minimum) long lag bolt through the base and into the wood pole to support the air terminal assembly.

Route the bare copper lightning conductor to maintain maximum horizontal separation from any risers that traverse up the pole. Secure the bare copper lightning conductor to the pole on 24” centers using copper cable clips. From the bottom of the pole (ground level) install a 2” by 10’ long PVC U-Guard over the bare copper lightning conductor to protect the cable from vandalism.

#### B. Copper Lightning Conductor and Ground Rods

Install the 4-point grounding system by installing a central grounding electrode that is surrounded by a minimum of three (3) additional grounding electrodes spaced approximately 20 feet away from the central grounding electrode and approximately 120 degrees apart. Interconnect each grounding electrode using a #4 AWG bare copper conductor back to the central grounding electrode using irreversible mechanical crimps. Additionally, using an irreversible mechanical crimp, connect the bare copper lightning conductor to the central grounding electrode. Install each grounding electrode and its corresponding #4 AWG bare copper grounding wire and 28 strand copper lightning conductor such that the wires are 24” below grade. Install marker tape 12” below grade and above all grounding conductors.

In instances where right-of-way does not allow for ground rod spacing as required above, reference the 2024 Roadway Standard Drawings - Section 1700.02 “Electrical Service Grounding” for “Limited Shoulder” or “Restricted Space” installation alternatives.

Prior to connecting the lightning protection system to an electrical service, perform a grounding electrode test on the lightning protection system to obtain a maximum of 20 ohms or less. Install additional grounding electrodes as need to obtain the 20 ohms or less requirement. The grounding electrode resistance test shall be verified or witnessed by the Engineer or the Engineer’s designated representative.

Follow test equipment’s procedures for measuring grounding electrode resistance. When using clamp-type ground resistance meters, readings of less than one ohm typically indicate a ground loop. Rework bonding and grounding circuits as necessary to remove ground loop circuits and retest. If a ground loop cannot be identified and removed to allow the proper use of a clamp-type ground resistance meter, use the three-point test method. Submit a completed inductive Loop & Grounding Test Form available on the Department’s website.

### 10.4. MEASUREMENT AND PAYMENT

No measurement will be made for furnishing and installing the “Air Terminal and Lightning Protection System” as this will be considered incidental to “CCTV Metal Pole” & “CCTV Wood Pole” installations.

## 11. DROP CABLE ASSEMBLY

### 11.1. DESCRIPTION

Furnish and install single mode fiber-optic (SMFO) drop cable assemblies.

### 11.2. MATERIALS

Furnish factory-preassembled, factory-preterminated drop assemblies with integral, pre-attached interconnect centers/patch panels designed to mount inside equipment cabinets. Furnish drop cable assemblies to provide communications links between splice enclosures and fiber-optic transceivers and match drop cable assemblies installed on prior projects.

Provide an assembly that is factory-assembled with the designated drop cable length. The assembly may be rail mounted or rack mounted. If the assembly is rack mounted it shall occupy only one rack unit.

Construct the drop cable assembly using single-mode, fiber-optic cable containing a minimum of six fibers. Furnish patch panel with a minimum of six ST connectors.

Furnish low bend radius single mode cable described above. A low bend radius cable is defined as a fiber-optic cable whose manufacturer-specified minimum bend radius does not exceed 5 inches when loaded and 4 inches when installed. Provide outdoor-rated, non-armored, riser rated cable. Provide UV-rated cable.

Use single-mode fiber-optic cable that does not exceed attenuation of 0.30 dB/km at 1550 nm and 0.40 dB/km at 1310 nm. Ensure attenuation loss for complete drop cable assembly does not exceed a mean value of 1.5 dB.

Provide metal connector housing, ceramic ferrules and coupler inserts. Provide a connector attenuation of .20 dB and a reflectance of < -40 dB SPC/<-55 dB UPC. Use heat-cured epoxy material.

Provide length markings in sequential feet and within one percent of actual cable length. Ensure character height of markings is approximately 0.10".

Furnish factory-assembled SMFO jumpers that are a minimum of 3 feet in length with LC/PC connectors on one end and ST/PC connectors at the other end for connecting Ethernet edge switches to the drop cable assembly's patch panel. Ensure SMFO jumpers meet the operating characteristics of the SMFO cable with which they are to be coupled.

### 11.3. CONSTRUCTION METHODS

Determine the length of drop cable needed, including slack, to reach from termination point to termination point.

Splice the free end of the drop cable assembly into the fiber-optic trunk cable in a splice enclosure external to the cabinet.

For existing riser locations, remove the existing weatherhead. Install fiber-optic drop cable and then install heat shrink tubing retrofit kit.

At aerial splice enclosures, install the aerial splice enclosure and corresponding cable storage rack at least 50 feet apart and store at least 50 feet of slack cable for each cable entering and exiting the splice enclosure between the splice enclosure and corresponding cable storage rack. Coil and

store any drop cable in excess of what is needed for overhead storage in the base of the equipment cabinet.

At below ground splice enclosures, coil at least 30 feet of slack cable for each cable entering and exiting the splice enclosure in the manhole or junction box where enclosure is located. Coil and store any drop cable in excess of what is needed for storage in the manhole or junction box in the base of the equipment cabinet.

Mount the drop cable assembly using screws to either the rack frame or rack mount in 19-inch equipment rack in a location convenient to the fiber-optic transceiver. Mount the drop cable assembly close enough to the fiber-optic transceiver to connect them using 3-foot fiber-optic jumpers. Secure drop cable in cabinet using cable ties and wire management hardware.

Install SMFO jumpers between the appropriate connectors on the patch panel of the drop cable assembly and the Ethernet edge switch or the video encoder.

Label all connectors, pigtails, and the connector panel. At the aerial splice enclosure location, cap off all unused fibers and label to correspond with the connector panel.

Where the Plans call for a fiber-optic drop cable to be installed in an existing riser, remove all existing cables from the riser and remove the existing weatherhead, sealing bushing or heat shrink tubing. Install the new fiber-optic drop cable in the existing riser and install new heat shrink tubing at the top of the existing riser using a heat shrink tubing retrofit kit. If the riser contains existing fiber-optic communications cable, carefully remove the fiber-optic cable from the riser so as not violate its minimum bending radius or otherwise damage the cable. Temporarily coil and store the existing fiber-optic cable overhead in a manner approved by the Engineer until the new drop cable can be spliced into the existing cable in an aerial splice enclosure.

Using an OTDR, test the end-to-end connectivity of the drop cable assembly from patch panel installed inside the signal cabinet to the corresponding communications hub. Comply with the OTDR testing and reporting requirements of the “Fiber-Optic Splice Centers” section of the *Standard Specifications* when testing drop cable.

**11.4. MEASUREMENT AND PAYMENT**

*Drop Cable Assembly (6-fiber)* will be measured and paid as the actual number of 6-strand fiber-optic drop cable assemblies of furnished, installed, and accepted.

No measurement will be made for terminating, splicing, and testing fiber-optic cable, communications cable identification markers, SMFO jumpers, as these will be considered incidental to the installation of drop cable assemblies.

Payment will be made under:

<b>Pay Item</b>	<b>Pay Unit</b>
Drop Cable Assembly (6-fiber) .....	Each



## 12. ELECTRICAL SERVICE FOR ITS DEVICES

### 12.1. DESCRIPTION

Install new electrical service equipment as shown in the plans. Installation of all new electrical service pedestals, poles, and meter base/disconnect combination panels shall be the first item of work on this project to expedite the power service connections. Comply with the National Electrical Code (NEC), the National Electrical Safety Code (NESC), the Standard Specifications, the Project Special Provisions, and all local ordinances. All work involving electrical service shall be coordinated with the appropriate utility company and the Engineer.

Obtain the maximum available ground fault current from the utility company. Print this information on a durable label and adhere to the dead front of the disconnect.

### 12.2. MATERIAL

#### A. Meter Base/Disconnect Combination Panel

Furnish and install new meter base/disconnect combination panels as shown in the Plans. Provide meter base/disconnect combination panels that have a minimum 125A main service disconnect and a minimum of eight (8) additional spaces. Furnish a single pole 15A circuit breaker at CCTV locations. Furnish a double pole 100A circuit breakers at dual DMS locations. Furnish each with a minimum of 10,000 RMS symmetrical amperes short circuit current rating in a lockable NEMA 3R enclosure. Ensure meter base/ disconnect combination panel is listed as meeting UL Standard UL-67 and marked as being suitable for use as service equipment. Ensure circuit breakers are listed as meeting UL-489. Place barriers so that no uninsulated, ungrounded service busbar or service terminal is exposed to inadvertent contact by persons or maintenance equipment while servicing load terminations. Fabricate enclosure from galvanized steel and electrostatically apply dry powder paint finish, light gray in color, to yield a minimum thickness of 2.4 mils. All exterior surfaces must be powder coated steel. Provide ground bus and neutral bus with a minimum of four terminals and a minimum wire capacity range of number 8 through number 3/0 AWG.

Furnish NEMA Type 3R combinational panels rated 100 Ampere minimum for overhead services and 200 Ampere minimum for underground services that meet the requirements of the local utility. Provide meter base with sockets' ampere rating based on sockets being wired with a minimum of 167 degrees F insulated wire. Furnish 4 terminal, 600 volt, single phase, 3-wire meter bases that comply with the following:

- Line, Load, and Neutral Terminals accept 4/0 AWG and smaller Copper/Aluminum wire
- With or without horn bypass
- Made of galvanized steel
- Listed as meeting UL Standard US-414
- Overhead or underground service entrance specified.

Furnish 1.5" watertight hub for threaded rigid conduit with meter base.

At the main service disconnect, furnish and install UL-approved lightning arrestors that meet the following requirements:



Type of design	Silicon Oxide Varistor
Voltage	120/240 Single Phase, 3 wire
Maximum current	100,000 amps
Maximum energy	3000 joules per pole
Maximum number of surges	Unlimited
Response time one milliamp test	5 nanoseconds
Response time to clamp 10,000 amps	10 nanoseconds
Response time to clamp 50,000 amps	25 nanoseconds
Leak current at double the rated voltage	None
Ground wire	Separate

**B. Equipment Cabinet Disconnect**

Provide new equipment cabinet disconnects at the locations shown in the Plans. Furnish a single pole 15A circuit breaker at CCTV locations. Furnish double pole 50A circuit breaker at single DMS locations. Furnish double pole 100A circuit breaker at dual DMS locations. Furnish panels that have a minimum of four (4) spaces in the disconnect. Furnish circuit breakers with a minimum of 10,000 RMS symmetrical amperes short circuit current rating in a lockable NEMA 3R enclosure. Ensure meter base/ disconnect combination panel is listed as meeting UL Standard UL-67 and marked as being suitable for use as service equipment. Ensure circuit breakers are listed as meeting UL-489. Fabricate enclosure from galvanized steel and electrostatically apply dry powder paint finish, light gray in color, to yield a minimum thickness of 2.4 mils. All exterior surfaces must be powder coated steel. Provide ground bus and neutral bus with a minimum of four terminals and a minimum wire capacity range of number 8 through number 3/0 AWG.

**C. 10KVA Single Phase General Purpose Transformer**

As shown on the Plans, furnish and install a double-wound, dry type general purpose transformer to isolate the line side voltages from the load side voltages as shown in the Plans. Provide the transformer with the following specifications:

- Primary Volts: 120/240 with 83/41 Amps Max. 60Hz.
- Secondary Volts: 120/240 with 83/41 Amps Max. 60Hz.
- 10 kVA power rating.
- Electrostatic shielding between primary and secondary windings.
- Epoxy-silica encapsulated core and coil.
- Copper windings and copper lead wire terminations.
- Multiple front and bottom knockout for conduit entry/exit.
- Ground studs for conduit bonding.

Provide the transformer in a NEMA 3R enclosure suitable for mounting to a metal or wood pole.

**D. 3-Wire Copper Service Entrance Conductors**

Furnish 3-wire stranded copper service entrance conductors with THWN rating. Provide conductors with black, red, and white insulation that are intended for power circuits at 600 Volts or less and comply with the following:

- Listed as meeting UL Standard UL-83
- Meets ASTM B-3 and B-8 or B-787 standards.

See the Plans for wire sizes and quantities.

**E. 3-Wire Copper Feeder Conductors**

Furnish 3-wire stranded copper feeder conductors with THWN rating for supplying power to ITS field equipment cabinets. Provide conductors with black or red, white, and green insulation that are intended for power circuits at 600 Volts or less and comply with the following:

- Listed as meeting UL Standard UL-83
- Meets ASTM B-3 and B-8 or B-787 standards.

See the Plans for wire sizes and quantities.

**F. Grounding System**

Furnish 5/8"x10' copper clad steel grounding electrodes (ground rods), #4 AWG solid bare copper conductors. Comply with the NEC, Standard Specifications, these Project Special Provisions, and the Plans.

**12.3. CONSTRUCTION METHODS****A. General**

Coordinate with the Engineer and the utility company to de-energize the existing service temporarily prior to starting any modifications.

Permanently label cables at all access points using nylon tags labeled with permanent ink. Ensure each cable has a unique identifier. Label cables immediately upon installation. Use component name and labeling scheme approved by the Engineer.

**B. Meter Base/Disconnect Combination Panel**

Install meter base/disconnect combination panels with lightning arrestors as called for in the Plans. At all new DMS locations, route the feeder conductors from the meter base/disconnect to the DMS equipment cabinet in conduit. At all new CCTV locations, route the feeder conductors from the meter base/disconnect to the CCTV equipment cabinet in conduit. Provide rigid galvanized conduit for above ground and PVC for below ground installations.

**C. Electrical Service Disconnect**

Install equipment cabinet disconnects and circuit breakers as called for in the Plans. Install THWN stranded copper feeder conductors as shown in Plans between the electrical service disconnect and the equipment cabinet disconnect. Route the conductors from the equipment cabinet disconnect to the equipment cabinet in rigid galvanized steel conduit. Bond the equipment cabinet disconnect in accordance with the NEC. Ensure that the grounding system complies with the

grounding requirements of these Project Special Provisions, the Standard Specifications and the Plans.

**D. 3-Wire Copper Service Entrance Conductors**

At locations shown in the Plans, furnish and install 3-wire THWN stranded copper service entrance conductors in 1.25 inch rigid galvanized risers as shown in the plans. Install a waterproof hub on top of the electrical service disconnect for riser entrance/exit. Size the conductors as specified in the Plans. Comply with the Standard Specifications and Standard Drawings and all applicable electrical codes.

**E. 3-Wire Copper Feeder Conductors**

At locations shown in the Plans, install 3-wire THWN stranded copper feeder conductors to supply 120 VAC to the CCTV field equipment cabinets. Size the conductors as specified in the Plans. Comply with the Standard Specifications and Standard Drawings and all applicable electrical codes.

**F. Grounding System**

Install ground rods as indicated in the Plans. Connect the #4 AWG grounding conductor to ground rods using an irreversible mechanical crimping method. Test the system to ensure a ground resistance of 20-ohms or less is achieved. Drive additional ground rods as necessary or as directed by the Engineer to achieve the proper ground resistance.

**12.4. MEASUREMENT AND PAYMENT**

*Meter base/disconnect combination panel* will be measured and paid as the actual number of complete and functional meter base/disconnect combination panel service locations furnished, installed and accepted. Breakers, lightning arrestors, exposed vertical conduit runs to the cabinet, and any remaining hardware, fittings, and conduit bodies to connect the electrical service to the cabinet will be considered incidental to meter base/disconnect combination panels.

*3-Wire copper service entrance conductors* will be incidental to furnish and installing the meter base/disconnect combination panel. All other required feeder conductors will be paid for separately.

*Equipment cabinet disconnect* will be measured and paid as the actual number of complete and functional equipment cabinet disconnects furnished, installed and accepted. Breakers, exposed vertical conduit runs to the cabinet, ground rods, ground wire and any remaining hardware and conduit to connect the equipment cabinet disconnect to the cabinet will be considered incidental to the equipment cabinet subpanel.

*10KVA Transformer* will be measured and paid in actual number of complete and functional 10KVA transformers furnished, installed and accepted. Enclosures, mounting hardware, pre-formed pad, and any remaining hardware, fittings, and conduit bodies to connect the isolation transformer will be considered incidental to the 10KVA transformer and will be considered incidental to the 10KVA

*3-Wire copper feeder conductors* will be measured and paid as the actual linear feet of 3-wire THWN stranded copper feeder conductors furnished, installed and accepted. Payment is for all three conductors. Measurement will be for the actual linear footage of combined conductors after all terminations are complete. No separate payment will be made for each individual conductor. No

**U-6202**

**TS-70**

**New Hanover County**

separate payment will be made for different wire sizes. No payment will be made for excess wire in the cabinets.

*5/8" X 10' grounding electrode* (ground rod) will be measured and paid as the actual number of 5/8" copper clad steel ground rods furnished, installed and accepted. No separate payment will be made for irreversible mechanical crimping tool as this will be considered incidental to the installation of the ground rod.

*#4 solid bare grounding conductor* will be measured and paid as the actual linear feet of #4 AWG solid bare copper grounding conductor furnished, installed and accepted. Measurement will be along the approximate centerline from the base of the electrical service disconnect to the last grounding electrode.

Payment will be made under:

<b>Pay Item</b>	<b>Pay Unit</b>
Meter Base/Disconnect Combination Panel .....	Each
Equipment Cabinet Disconnect.....	Each
3-Wire Copper Service Entrance Conductors.....	Linear Foot
3-Wire Copper Feeder Conductors .....	Linear Foot
5/8" X 10' Grounding Electrode.....	Each
#4 Solid Bare Grounding Conductor .....	Linear Foot

County: NEW HANOVER

Line #	Item Number	Sec #	Description	Quantity	Unit Cost	Amount
<b>ROADWAY ITEMS</b>						
0001	0000100000-N	800	MOBILIZATION	Lump Sum	L.S.	
0002	0000400000-N	801	CONSTRUCTION SURVEYING	Lump Sum	L.S.	
0003	0015000000-N	205	SEALING ABANDONED WELLS	6 EA		
0004	0043000000-N	226	GRADING	Lump Sum	L.S.	
0005	0050000000-E	226	SUPPLEMENTARY CLEARING & GRUBBING	1 ACR		
0006	0057000000-E	226	UNDERCUT EXCAVATION	5,400 CY		
0007	0134000000-E	240	DRAINAGE DITCH EXCAVATION	150 CY		
0008	0195000000-E	265	SELECT GRANULAR MATERIAL	5,400 CY		
0009	0196000000-E	270	GEOTEXTILE FOR SOIL STABILIZATION	4,300 SY		
0010	0199000000-E	SP	TEMPORARY SHORING	2,140 SF		
0011	0255000000-E	SP	GENERIC GRADING ITEM HAULING AND DISPOSAL OF PETROLEUM CONTAMINATED SOIL	50 TON		
0012	0318000000-E	300	FOUNDATION CONDITIONING MATERIAL, MINOR STRUCTURES	4,937.7 TON		
0013	0321000000-E	300	FOUNDATION CONDITIONING GEOTEXTILE	16,455 SY		
0014	0335200000-E	305	15" DRAINAGE PIPE	83 LF		
0015	0335500000-E	305	30" DRAINAGE PIPE	128 LF		
0016	0448000000-E	310	***** RC PIPE CULVERTS, CLASS IV (48")	392 LF		
0017	0448000000-E	310	***** RC PIPE CULVERTS, CLASS IV (54")	208 LF		

County: NEW HANOVER

Line #	Item Number	Sec #	Description	Quantity	Unit Cost	Amount
0018	0448000000-E	310	***** RC PIPE CULVERTS, CLASS IV (66")	156 LF		
0019	0448200000-E	310	15" RC PIPE CULVERTS, CLASS IV	11,084 LF		
0020	0448300000-E	310	18" RC PIPE CULVERTS, CLASS IV	4,092 LF		
0021	0448400000-E	310	24" RC PIPE CULVERTS, CLASS IV	5,456 LF		
0022	0448500000-E	310	30" RC PIPE CULVERTS, CLASS IV	1,608 LF		
0023	0448600000-E	310	36" RC PIPE CULVERTS, CLASS IV	1,576 LF		
0024	0448700000-E	310	42" RC PIPE CULVERTS, CLASS IV	2,764 LF		
0025	0449000000-E	310	*** RC PIPE CULVERTS, CLASS V (18")	52 LF		
0026	0973100000-E	330	*** WELDED STEEL PIPE, ***** THICK, GRADE B IN SOIL (36", 0.532")	80 LF		
0027	0973300000-E	330	*** WELDED STEEL PIPE, ***** THICK, GRADE B NOT IN SOIL (36", 0.532")	80 LF		
0028	0995000000-E	340	PIPE REMOVAL	9,869 LF		
0029	1099500000-E	505	SHALLOW UNDERCUT	100 CY		
0030	1099700000-E	505	CLASS IV SUBGRADE STABILIZATION	190 TON		
0031	1111000000-E	SP	CLASS IV AGGREGATE STABILIZATION	500 TON		
0032	1112000000-E	505	GEOTEXTILE FOR SUBGRADE STABILIZATION	300 SY		
0033	1121000000-E	520	AGGREGATE BASE COURSE	4,500 TON		
0034	1220000000-E	545	INCIDENTAL STONE BASE	1,000 TON		

County: NEW HANOVER

Line #	Item Number	Sec #	Description	Quantity	Unit Cost	Amount
0035	1297000000-E	607	MILLING ASPHALT PAVEMENT, **** DEPTH (1-1/2")	1,070 SY		
0036	1297000000-E	607	MILLING ASPHALT PAVEMENT, **** DEPTH (3")	2,800 SY		
0037	1330000000-E	607	INCIDENTAL MILLING	4,700 SY		
0038	1491000000-E	610	ASPHALT CONC BASE COURSE, TYPE B25.0C	21,600 TON		
0039	1503000000-E	610	ASPHALT CONC INTERMEDIATE COURSE, TYPE I19.0C	16,800 TON		
0040	1519000000-E	610	ASPHALT CONC SURFACE COURSE, TYPE S9.5B	21,000 TON		
0041	1523000000-E	610	ASPHALT CONC SURFACE COURSE, TYPE S9.5C	890 TON		
0042	1575000000-E	620	ASPHALT BINDER FOR PLANT MIX	3,200 TON		
0043	1693000000-E	654	ASPHALT PLANT MIX, PAVEMENT REPAIR	2,700 TON		
0044	2022000000-E	815	SUBDRAIN EXCAVATION	1,406 CY		
0045	2026000000-E	815	GEOTEXTILE FOR SUBSURFACE DRAINS	6,276 SY		
0046	2036000000-E	815	SUBDRAIN COARSE AGGREGATE	1,054 CY		
0047	2044000000-E	815	6" PERFORATED SUBDRAIN PIPE	6,276 LF		
0048	2070000000-N	815	SUBDRAIN PIPE OUTLET	13 EA		
0049	2077000000-E	815	6" OUTLET PIPE	78 LF		
0050	2190000000-N	828	TEMPORARY STEEL PLATE COVERS FOR MASONRY DRAINAGE STRUCTURE	58 EA		
0051	2209000000-E	838	ENDWALLS	7.9 CY		



County: NEW HANOVER

Line #	Item Number	Sec #	Description	Quantity	Unit Cost	Amount
0052	2220000000-E	838	REINFORCED ENDWALLS	11.5 CY		
0053	2275000000-E	SP	FLOWABLE FILL	21 CY		
0054	2286000000-N	840	MASONRY DRAINAGE STRUCTURES	337 EA		
0055	2297000000-E	840	MASONRY DRAINAGE STRUCTURES	18.165 CY		
0056	2308000000-E	840	MASONRY DRAINAGE STRUCTURES	60.5 LF		
0057	2364000000-N	840	FRAME WITH TWO GRATES, STD 840.16	69 EA		
0058	2366000000-N	840	FRAME WITH TWO GRATES, STD 840.24	19 EA		
0059	2367000000-N	840	FRAME WITH TWO GRATES, STD 840.29	38 EA		
0060	2374000000-N	840	FRAME WITH GRATE & HOOD, STD 840.03, TYPE ** (E)	46 EA		
0061	2374000000-N	840	FRAME WITH GRATE & HOOD, STD 840.03, TYPE ** (F)	87 EA		
0062	2374000000-N	840	FRAME WITH GRATE & HOOD, STD 840.03, TYPE ** (G)	78 EA		
0063	2396000000-N	840	FRAME WITH COVER, STD 840.54	13 EA		
0064	2451000000-N	852	CONCRETE TRANSITIONAL SECTION FOR DROP INLET	60 EA		
0065	2542000000-E	846	1'-6" CONCRETE CURB & GUTTER	5,500 LF		
0066	2549000000-E	846	2'-6" CONCRETE CURB & GUTTER	28,500 LF		
0067	2556000000-E	846	SHOULDER BERM GUTTER	270 LF		
0068	2580000000-E	846	CONCRETE VALLEY GUTTER	1,400 LF		

County: NEW HANOVER

Line #	Item Number	Sec #	Description	Quantity	Unit Cost	Amount
0069	2591000000-E	848	4" CONCRETE SIDEWALK	6,440 SY		
0070	2605000000-N	848	CONCRETE CURB RAMPS	106 EA		
0071	2612000000-E	848	6" CONCRETE DRIVEWAY	3,090 SY		
0072	2655000000-E	852	5" MONOLITHIC CONCRETE ISLANDS (KEYED IN)	5,380 SY		
0073	2800000000-N	858	ADJUSTMENT OF CATCH BASINS	4 EA		
0074	2815000000-N	858	ADJUSTMENT OF DROP INLETS	6 EA		
0075	2860000000-N	859	CONVERT EXISTING CATCH BASIN TO JUNCTION BOX	1 EA		
0076	2905000000-N	859	CONVERT EXISTING DROP INLET TO JUNCTION BOX	2 EA		
0077	3030000000-E	862	STEEL BEAM GUARDRAIL	300 LF		
0078	3150000000-N	862	ADDITIONAL GUARDRAIL POSTS	5 EA		
0079	3287000000-N	862	GUARDRAIL END UNITS, TYPE TL-3	1 EA		
0080	3360000000-E	863	REMOVE EXISTING GUARDRAIL	350 LF		
0081	3380000000-E	862	TEMPORARY STEEL BEAM GUARDRAIL	50 LF		
0082	3389150000-N	862	TEMPORARY GUARDRAIL END UNITS, TYPE ***** (TL-3)	2 EA		
0083	3389160000-N	862	TEMPORARY ADDITIONAL GUARDRAIL POSTS	5 EA		
0084	3574000000-E	867	GENERIC FENCING ITEM 120" WOODEN PRIVACY FENCE RESET	200 LF		
0085	3575000000-E	SP	GENERIC FENCING ITEM STEEL PIPE HANDRAIL	890 LF		

County: NEW HANOVER

Line #	Item Number	Sec #	Description	Quantity	Unit Cost	Amount
0086	3628000000-E	876	RIP RAP, CLASS I	2,415 TON		
0087	3649000000-E	876	RIP RAP, CLASS B	60 TON		
0088	3656000000-E	876	GEOTEXTILE FOR DRAINAGE	5,200 SY		
0089	4048000000-E	902	REINFORCED CONCRETE SIGN FOUNDATIONS	2 CY		
0090	4060000000-E	903	SUPPORTS, BREAKAWAY STEEL BEAM	1,713 LB		
0091	4072000000-E	903	SUPPORTS, 3-LB STEEL U-CHANNEL	3,002 LF		
0092	4096000000-N	904	SIGN ERECTION, TYPE D	5 EA		
0093	4102000000-N	904	SIGN ERECTION, TYPE E	158 EA		
0094	4108000000-N	904	SIGN ERECTION, TYPE F	12 EA		
0095	4110000000-N	904	SIGN ERECTION, TYPE *** (GROUND MOUNTED) (A)	1 EA		
0096	4116100000-N	904	SIGN ERECTION, RELOCATE TYPE **** (GROUND MOUNTED) (A)	2 EA		
0097	4116100000-N	904	SIGN ERECTION, RELOCATE TYPE **** (GROUND MOUNTED) (D)	6 EA		
0098	4138000000-N	907	DISPOSAL OF SUPPORT, STEEL BEAM	4 EA		
0099	4141000000-N	907	DISPOSAL OF SUPPORT, WOOD	1 EA		
0100	4155000000-N	907	DISPOSAL OF SIGN SYSTEM, U-CHANNEL	76 EA		
0101	4192000000-N	907	DISPOSAL OF SUPPORT, U-CHANNEL	5 EA		

County: NEW HANOVER

Line #	Item Number	Sec #	Description	Quantity	Unit Cost	Amount
0102	4360000000-N	SP	GENERIC SIGNING ITEM SIGN ERECTION, RELOCATE, LOGO TRAILBLAZER	2 EA		
0103	4360000000-N	SP	GENERIC SIGNING ITEM STOCKPILE OF SIGN, LOGO TRAILBLAZER	2 EA		
0104	4360000000-N	SP	GENERIC SIGNING ITEM VERTICAL PANEL TYPE 3 OBJECT MARKER - OM3-C	10 EA		
0105	4360000000-N	SP	GENERIC SIGNING ITEM VERTICAL PANEL TYPE 3 OBJECT MARKER - OM3-L	25 EA		
0106	4400000000-E	1110	WORK ZONE SIGNS (STATIONARY)	808 SF		
0107	4405000000-E	1110	WORK ZONE SIGNS (PORTABLE)	464 SF		
0108	4410000000-E	1110	WORK ZONE SIGNS (BARRICADE MOUNTED)	245 SF		
0109	4415000000-N	1115	FLASHING ARROW BOARD	2 EA		
0110	4420000000-N	1120	PORTABLE CHANGEABLE MESSAGE SIGN	4 EA		
0111	4422000000-N	1120	PORTABLE CHANGEABLE MESSAGE SIGN (SHORT TERM)	28 DAY		
0112	4430000000-N	1130	DRUMS	522 EA		
0113	4435000000-N	1135	CONES	122 EA		
0114	4445000000-E	1145	BARRICADES (TYPE III)	1,336 LF		
0115	4455000000-N	1150	FLAGGER	1,140 DAY		
0116	4465000000-N	1160	TEMPORARY CRASH CUSHIONS	4 EA		
0117	4480000000-N	1165	TMA	2 EA		

County: NEW HANOVER

Line #	Item Number	Sec #	Description	Quantity	Unit Cost	Amount
0118	4490000000-E	1170	PORTABLE CONCRETE BARRIER (ANCHORED)	421 LF		
0119	4510000000-N	1190	LAW ENFORCEMENT	144 HR		
0120	4516000000-N	1180	SKINNY DRUM	350 EA		
0121	4590000000-E	SP	GENERIC TRAFFIC CONTROL ITEM PEDESTRIAN CHANNELIZING DEVICES	168 LF		
0122	4600000000-N	SP	GENERIC TRAFFIC CONTROL ITEM AUDIBLE WARNING DEVICES	21 EA		
0123	4600000000-N	SP	GENERIC TRAFFIC CONTROL ITEM TEMPORARY CURB RAMPS	4 EA		
0124	4650000000-N	1251	TEMPORARY RAISED PAVEMENT MARKERS	1,964 EA		
0125	4685000000-E	1205	THERMOPLASTIC PAVEMENT MARKING LINES (4", 90 MILS)	48,297 LF		
0126	4688000000-E	1205	THERMOPLASTIC PAVEMENT MARKING LINES (6", 90 MILS)	2,409 LF		
0127	4695000000-E	1205	THERMOPLASTIC PAVEMENT MARKING LINES (8", 90 MILS)	7,999 LF		
0128	4700000000-E	1205	THERMOPLASTIC PAVEMENT MARKING LINES (12", 90 MILS)	262 LF		
0129	4709000000-E	1205	THERMOPLASTIC PAVEMENT MARKING LINES (24", 90 MILS)	3,679 LF		
0130	4720000000-E	1205	THERMOPLASTIC PAVEMENT MARKING CHARACTER (90 MILS)	68 EA		
0131	4725000000-E	1205	THERMOPLASTIC PAVEMENT MARKING SYMBOL (90 MILS)	280 EA		
0132	4810000000-E	1205	PAINT PAVEMENT MARKING LINES (4")	141,804 LF		
0133	4815000000-E	1205	PAINT PAVEMENT MARKING LINES (6")	4,652 LF		
0134	4820000000-E	1205	PAINT PAVEMENT MARKING LINES (8")	35,008 LF		

County: NEW HANOVER

Line #	Item Number	Sec #	Description	Quantity	Unit Cost	Amount
0135	4825000000-E	1205	PAINT PAVEMENT MARKING LINES (12")	16 LF		
0136	4835000000-E	1205	PAINT PAVEMENT MARKING LINES (24")	3,212 LF		
0137	4840000000-N	1205	PAINT PAVEMENT MARKING CHARACTER	48 EA		
0138	4845000000-N	1205	PAINT PAVEMENT MARKING SYMBOL	309 EA		
0139	4850000000-E	1205	REMOVAL OF PAVEMENT MARKING LINES (4")	32,838 LF		
0140	4860000000-E	1205	REMOVAL OF PAVEMENT MARKING LINES (8")	6,808 LF		
0141	4870000000-E	1205	REMOVAL OF PAVEMENT MARKING LINES (24")	535 LF		
0142	4875000000-N	1205	REMOVAL OF PAVEMENT MARKING SYMBOLS & CHARACTERS	112 EA		
0143	4895000000-N	SP	GENERIC PAVEMENT MARKING ITEM POLYCARBONATE H-SHAPED MARKERS	1,561 EA		
0144	5255000000-N	1413	PORTABLE LIGHTING	Lump Sum	L.S.	
0145	5325600000-E	1510	6" WATER LINE	987.5 LF		
0146	5325800000-E	1510	8" WATER LINE	7,042.5 LF		
0147	5326000000-E	1510	10" WATER LINE	124 LF		
0148	5326200000-E	1510	12" WATER LINE	1,132 LF		
0149	5326600000-E	1510	16" WATER LINE	9,111 LF		
0150	5329000000-E	1510	DUCTILE IRON WATER PIPE FITTINGS	64,535 LB		
0151	5540000000-E	1515	6" VALVE	19 EA		

County: NEW HANOVER

Line #	Item Number	Sec #	Description	Quantity	Unit Cost	Amount
0152	5546000000-E	1515	8" VALVE	43 EA		
0153	5552000000-E	1515	10" VALVE	3 EA		
0154	5558000000-E	1515	12" VALVE	6 EA		
0155	5558600000-E	1515	16" VALVE	22 EA		
0156	5571600000-E	1515	6" TAPPING SLEEVE & VALVE	3 EA		
0157	5606000000-E	1515	2" BLOW OFF	6 EA		
0158	5643000000-E	1515	*** WATER METER (5/8")	27 EA		
0159	5648000000-N	1515	RELOCATE WATER METER	43 EA		
0160	5649000000-N	1515	RECONNECT WATER METER	5 EA		
0161	5656100000-E	1515	RELOCATE *** RPZ BACKFLOW PREVENTION ASSEMBLY (1")	1 EA		
0162	5656210000-E	1515	RELOCATE 2" RPZ BACKFLOW PREVENTION ASSEMBLY	9 EA		
0163	5666000000-N	1515	FIRE HYDRANT	1 EA		
0164	5672000000-N	1515	RELOCATE FIRE HYDRANT	17 EA		
0165	5673000000-E	1515	FIRE HYDRANT LEG	130 LF		
0166	5686500000-E	1515	WATER SERVICE LINE	1,432 LF		
0167	5691300000-E	1520	8" SANITARY GRAVITY SEWER	1,705 LF		
0168	5691400000-E	1520	10" SANITARY GRAVITY SEWER	160 LF		



County: NEW HANOVER

Line #	Item Number	Sec #	Description	Quantity	Unit Cost	Amount
0169	5709100000-E	1520	2" FORCE MAIN SEWER	702 LF		
0170	5768000000-N	1520	SANITARY SEWER CLEAN-OUT	14 EA		
0171	5768500000-E	1520	SEWER SERVICE LINE	491 LF		
0172	5769000000-E	1520	DUCTILE IRON SEWER PIPE FITTINGS	48 LB		
0173	5775000000-E	1525	4' DIA UTILITY MANHOLE	11 EA		
0174	5776000000-E	1525	5' DIA UTILITY MANHOLE	2 EA		
0175	5781000000-E	1525	UTILITY MANHOLE WALL 4' DIA	46.7 LF		
0176	5782000000-E	1525	UTILITY MANHOLE WALL 5' DIA	11.7 LF		
0177	5800000000-E	1530	ABANDON 6" UTILITY PIPE	470 LF		
0178	5801000000-E	1530	ABANDON 8" UTILITY PIPE	4,851 LF		
0179	5802000000-E	1530	ABANDON 10" UTILITY PIPE	159 LF		
0180	5804000000-E	1530	ABANDON 12" UTILITY PIPE	1,009 LF		
0181	5810000000-E	1530	ABANDON 16" UTILITY PIPE	8,754 LF		
0182	5815000000-N	1530	REMOVE WATER METER	2 EA		
0183	5816000000-N	1530	ABANDON UTILITY MANHOLE	3 EA		
0184	5828000000-N	1530	REMOVE UTILITY MANHOLE	5 EA		
0185	5835000000-E	1540	*** ENCASEMENT PIPE (28")	174 LF		

County: NEW HANOVER

Line #	Item Number	Sec #	Description	Quantity	Unit Cost	Amount
0186	5835700000-E	1540	16" ENCASEMENT PIPE	448 LF		
0187	5836000000-E	1540	24" ENCASEMENT PIPE	76 LF		
0188	5836400000-E	1540	36" ENCASEMENT PIPE	70 LF		
0189	5872500000-E	1550	BORE AND JACK OF *** (16")	460 LF		
0190	5872500000-E	1550	BORE AND JACK OF *** (24")	78 LF		
0191	5872500000-E	1550	BORE AND JACK OF *** (36")	73 LF		
0192	5872600000-E	1550	DIRECTIONAL DRILLING OF *** (16")	362 LF		
0193	5882000000-N	SP	GENERIC UTILITY ITEM ADJUST EXISTING MANHOLE TO GRADE	3 EA		
0194	5882000000-N	SP	GENERIC UTILITY ITEM CONNECT EXISTING LINE TO PROPOSED MANHOLE	6 EA		
0195	5882000000-N	SP	GENERIC UTILITY ITEM CONNECT PROPOSED FORCE MAIN LINE TO EXISTING MANHOLE	1 EA		
0196	5882000000-N	SP	GENERIC UTILITY ITEM CONNECT PROPOSED SEWER LINE TO EXISTING MANHOLE	3 EA		
0197	5882000000-N	SP	GENERIC UTILITY ITEM RELOCATION OF SAMPLING STATION	4 EA		
0198	6000000000-E	1605	TEMPORARY SILT FENCE	37,000 LF		
0199	6006000000-E	1610	STONE FOR EROSION CONTROL, CLASS A	3,310 TON		
0200	6009000000-E	1610	STONE FOR EROSION CONTROL, CLASS B	1,915 TON		
0201	6012000000-E	1610	SEDIMENT CONTROL STONE	4,995 TON		

County: NEW HANOVER

Line #	Item Number	Sec #	Description	Quantity	Unit Cost	Amount
0202	6015000000-E	1615	TEMPORARY MULCHING	31.5 ACR		
0203	6018000000-E	1620	SEED FOR TEMPORARY SEEDING	1,800 LB		
0204	6021000000-E	1620	FERTILIZER FOR TEMPORARY SEEDING	9 TON		
0205	6024000000-E	1622	TEMPORARY SLOPE DRAINS	200 LF		
0206	6029000000-E	SP	SAFETY FENCE	4,600 LF		
0207	6030000000-E	1630	SILT EXCAVATION	8,100 CY		
0208	6036000000-E	1631	MATTING FOR EROSION CONTROL	11,000 SY		
0209	6037000000-E	1629	COIR FIBER MAT	2,575 SY		
0210	6042000000-E	1632	1/4" HARDWARE CLOTH	12,400 LF		
0211	6043000000-E	1644	LOW PERMEABILITY GEOTEXTILE	2,300 SY		
0212	6045000000-E	SP	*** TEMPORARY PIPE (18")	45 LF		
0213	6045000000-E	SP	*** TEMPORARY PIPE (48")	325 LF		
0214	6070000000-N	1639	SPECIAL STILLING BASINS	6 EA		
0215	6071002000-E	1642	FLOCCULANT	710 LB		
0216	6071012000-E	1642	COIR FIBER WATTLE	4,200 LF		
0217	6071030000-E	1640	COIR FIBER BAFFLE	1,000 LF		
0218	6084000000-E	1660	SEEDING & MULCHING	30 ACR		

County: NEW HANOVER

Line #	Item Number	Sec #	Description	Quantity	Unit Cost	Amount
0219	6087000000-E	1660	MOWING	21 ACR		
0220	6090000000-E	1661	SEED FOR REPAIR SEEDING	350 LB		
0221	6093000000-E	1661	FERTILIZER FOR REPAIR SEEDING	1 TON		
0222	6096000000-E	1662	SEED FOR SUPPLEMENTAL SEEDING	600 LB		
0223	6108000000-E	1665	FERTILIZER TOPDRESSING	18 TON		
0224	6111000000-E	SP	IMPERVIOUS DIKE	60 LF		
0225	6114500000-N	1667	SPECIALIZED HAND MOWING	10 MHR		
0226	6117000000-N	1675	RESPONSE FOR EROSION CONTROL	75 EA		
0227	6117500000-N	SP	CONCRETE WASHOUT STRUCTURE	15 EA		
0228	6132000000-N	SP	GENERIC EROSION CONTROL ITEM FABRIC INSERT INLET PROTECTION CLEANOUT	1,050 EA		
0229	6132000000-N	SP	GENERIC EROSION CONTROL ITEM FABRIC INSERT INLET PROTECTION, TYPE 1	350 EA		
0230	7048500000-E	1705	PEDESTRIAN SIGNAL HEAD (16", 1 SECTION W/COUNTDOWN)	50 EA		
0231	7060000000-E	1705	SIGNAL CABLE	30,820 LF		
0232	7120000000-E	1705	VEHICLE SIGNAL HEAD (12", 3 SECTION)	138 EA		
0233	7132000000-E	1705	VEHICLE SIGNAL HEAD (12", 4 SECTION)	33 EA		
0234	7144000000-E	1705	VEHICLE SIGNAL HEAD (12", 5 SECTION)	8 EA		
0235	7252000000-E	1710	MESSENGER CABLE (1/4")	11,175 LF		

County: NEW HANOVER

Line #	Item Number	Sec #	Description	Quantity	Unit Cost	Amount
0236	7264000000-E	1710	MESSENGER CABLE (3/8")	4,390 LF		
0237	7279000000-E	1715	TRACER WIRE	3,490 LF		
0238	7300000000-E	1715	UNPAVED TRENCHING (***** (1, 2")	710 LF		
0239	7300000000-E	1715	UNPAVED TRENCHING (***** (2, 2")	330 LF		
0240	7300000000-E	1715	UNPAVED TRENCHING (***** (3, 2")	1,055 LF		
0241	7300000000-E	1715	UNPAVED TRENCHING (***** (4, 2")	130 LF		
0242	7301000000-E	1715	DIRECTIONAL DRILL (***** (1, 2")	515 LF		
0243	7301000000-E	1715	DIRECTIONAL DRILL (***** (2, 2")	3,550 LF		
0244	7301000000-E	1715	DIRECTIONAL DRILL (***** (3, 2")	155 LF		
0245	7312000000-N	1716	JUNCTION BOX (***** (SPECIAL OVERSIZED HEAVY DUTY)	3 EA		
0246	7324000000-N	1716	JUNCTION BOX (STANDARD SIZE)	38 EA		
0247	7348000000-N	1716	JUNCTION BOX (OVER-SIZED, HEAVY DUTY)	29 EA		
0248	7360000000-N	1720	WOOD POLE	27 EA		
0249	7372000000-N	1721	GUY ASSEMBLY	58 EA		
0250	7408000000-E	1722	1" RISER WITH WEATHERHEAD	8 EA		
0251	7420000000-E	1722	2" RISER WITH WEATHERHEAD	21 EA		
0252	7430000000-N	1722	HEAT SHRINK TUBING RETROFIT KIT	2 EA		

County: NEW HANOVER

Line #	Item Number	Sec #	Description	Quantity	Unit Cost	Amount
0253	7432000000-E	1722	2" RISER WITH HEAT SHRINK TUBING	9 EA		
0254	7456100000-E	1726	LEAD-IN CABLE (14-2)	11,095 LF		
0255	7516000000-E	1730	COMMUNICATIONS CABLE (** FIBER) (24)	15,560 LF		
0256	7540000000-N	1731	SPLICE ENCLOSURE	8 EA		
0257	7541000000-N	1731	MODIFY SPLICE ENCLOSURE	2 EA		
0258	7566000000-N	1733	DELINEATOR MARKER	20 EA		
0259	7575142010-N	1736	900MHZ SERIAL/ETHERNET SPREAD SPECTRUM RADIO	8 EA		
0260	7575160000-E	1734	REMOVE EXISTING COMMUNICATIONS CABLE	595 LF		
0261	7576000000-N	SP	METAL STRAIN SIGNAL POLE	8 EA		
0262	7588000000-N	SP	METAL POLE WITH SINGLE MAST ARM	13 EA		
0263	7590000000-N	SP	METAL POLE WITH DUAL MAST ARM	4 EA		
0264	7613000000-N	SP	SOIL TEST	28 EA		
0265	7614100000-E	SP	DRILLED PIER FOUNDATION	150 CY		
0266	7631000000-N	SP	MAST ARM WITH METAL POLE DESIGN	17 EA		
0267	7636000000-N	1745	SIGN FOR SIGNALS	26 EA		
0268	7642200000-N	1743	TYPE II PEDESTAL WITH FOUNDATION	42 EA		
0269	7684000000-N	1750	SIGNAL CABINET FOUNDATION	10 EA		

County: NEW HANOVER

Line #	Item Number	Sec #	Description	Quantity	Unit Cost	Amount
0271	7901000000-N	1753	CABINET BASE EXTENDER	10 EA		
0272	7960000000-N	SP	METAL POLE FOUNDATION REMOVAL	3 EA		
0273	7972000000-N	SP	METAL POLE REMOVAL	3 EA		
0274	7980000000-N	SP	GENERIC SIGNAL ITEM 5/8" X 10' GROUNDING ELECTRODE	8 EA		
0275	7980000000-N	SP	GENERIC SIGNAL ITEM CCTV WOOD POLE	2 EA		
0276	7980000000-N	SP	GENERIC SIGNAL ITEM DIGITAL CCTV CAMERA ASSEMBLY	2 EA		
0277	7980000000-N	SP	GENERIC SIGNAL ITEM DROP CABLE ASSEMBLY (6-FIBER)	11 EA		
0278	7980000000-N	SP	GENERIC SIGNAL ITEM EQUIPMENT CABINET DISCONNECT	1 EA		
0279	7980000000-N	SP	GENERIC SIGNAL ITEM ETHERNET EDGE SWITCH	11 EA		
0280	7980000000-N	SP	GENERIC SIGNAL ITEM FIELD EQUIPMENT CABINET	2 EA		
0281	7980000000-N	SP	GENERIC SIGNAL ITEM METER BASE/DISCONNECT COMBINATION PANEL	2 EA		
0282	7980000000-N	SP	GENERIC SIGNAL ITEM MICROWAVE VEHICLE DETECTION SYSTEM - MULTIPLE ZONES	20 EA		
0283	7990000000-E	SP	GENERIC SIGNAL ITEM #4 SOLID BARE GROUNDING CONDUCTOR	140 LF		
0284	7990000000-E	SP	GENERIC SIGNAL ITEM 3-WIRE COPPER FEEDER CONDUCTORS	180 LF		
0285	7990000000-E	SP	GENERIC SIGNAL ITEM 3-WIRE COPPER SERVICE ENTRANCE CONDUCTORS	60 LF		
0291	7980000000-N	SP	GENERIC SIGNAL ITEM INSTALL DEPARTMENT SUPPLIED 2070 CONTROLLER	9 EA		



County: NEW HANOVER

Line #	Item Number	Sec #	Description	Quantity	Unit Cost	Amount
0292	7980000000-N	SP	GENERIC SIGNAL ITEM CABINET WITHOUT CONTROLLER (TYPE 170E, BASE MOUNTED)	9 EA		
-----						
<b>CULVERT ITEMS</b>						
0286	8056000000-N	402	REMOVAL OF EXISTING STRUCTURE AT STATION ***** (98+33.00 -L-)	Lump Sum	L.S.	
0287	8130000000-N	414	BOX CULVERT EXCAVATION, STA ***** (98+33.00 -L-)	Lump Sum	L.S.	
0288	8133000000-E	414	FOUNDATION CONDITIONING MATERIAL, BOX CULVERT	226 TON		
0289	8196000000-E	420	CLASS A CONCRETE (CULVERT)	274.3 CY		
0290	8245000000-E	425	REINFORCING STEEL (CULVERT)	58,691 LB		
-----						

1309/Nov13/Q884696.965/D1371026966010/E291

Total Amount Of Bid For Entire Project :

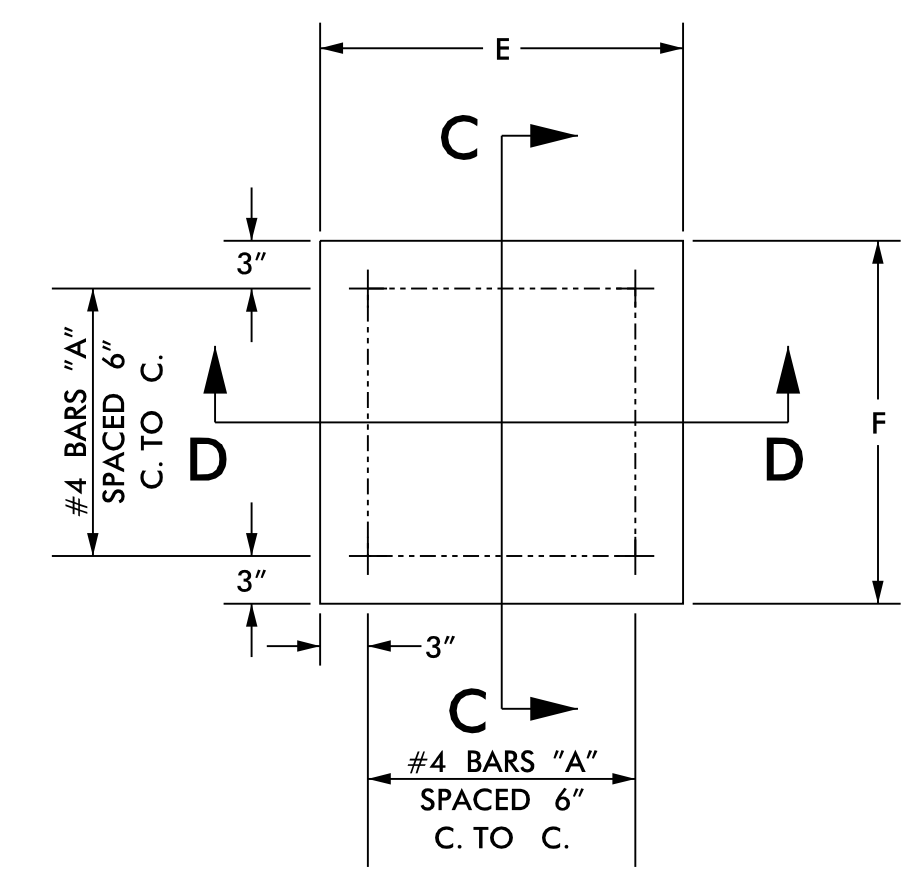
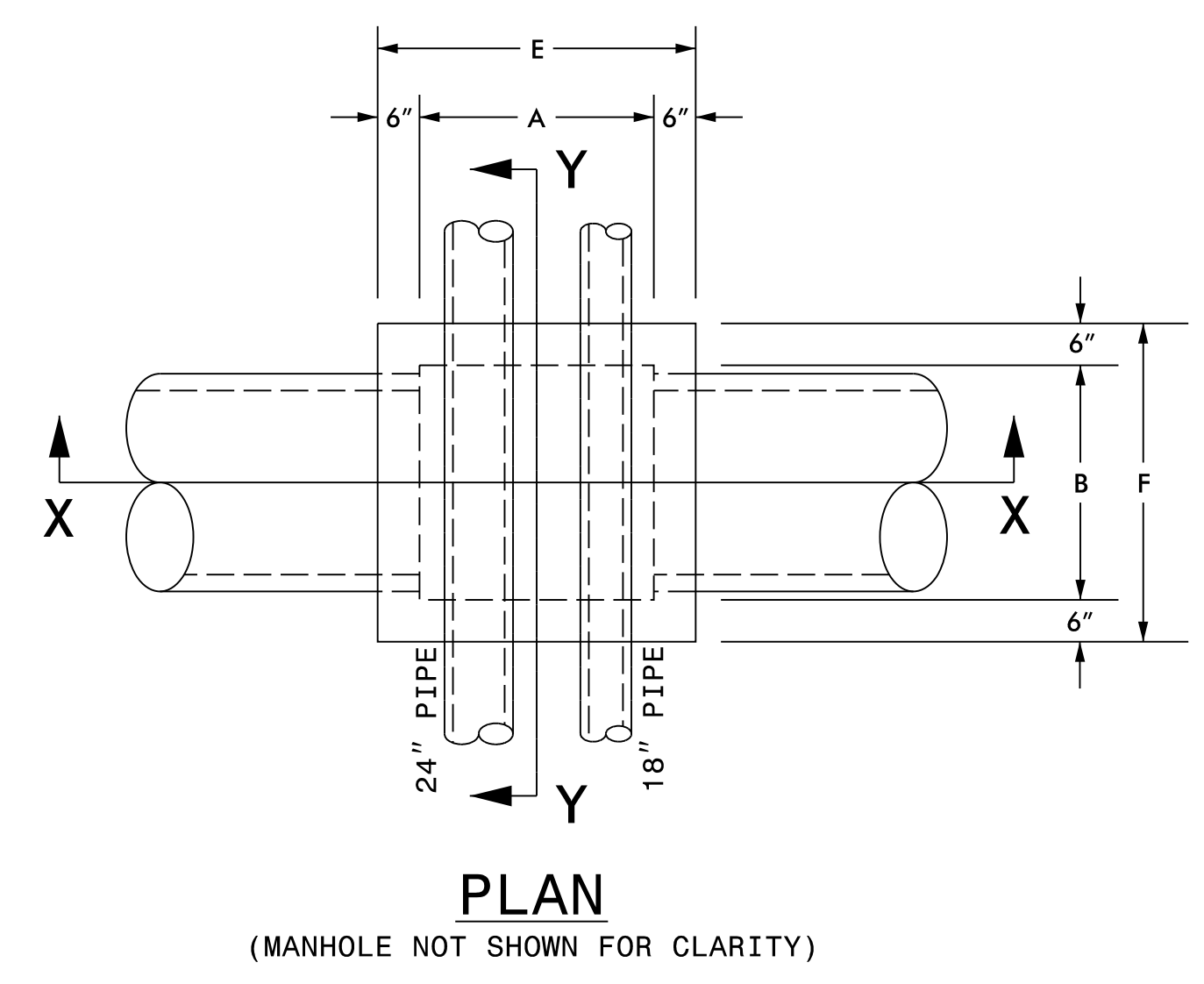

- GENERAL NOTES:**
1. CHAMFER ALL EXPOSED CORNERS 1"
  2. USE CLASS "B" CONCRETE THROUGHOUT
  3. OPTIONAL CONSTRUCTION - MONOLITHIC POUR, 2" KEYWAY, OR #4 BAR DOWELS AT 12" CENTERS AS DIRECTED BY THE ENGINEER
  4. USE FORMS TO CONSTRUCT THE BOTTOM SLAB
  5. IF REINFORCED CONCRETE PIPE IS SET IN BASE SLAB OF BOX, ADD TO BASE AS SHOWN ON STANDARD NO. 840.00
  6. REFER TO R.S.D.N. 840.31 FOR PLACEMENT OF MANHOLE COVER IN JUNCTION BOX
  7. NO SEPARATE PAYMENT WILL BE MADE FOR ENCASEMENT PIPES. THEY ARE TO BE CONSIDERED INCIDENTAL TO THE DRAINAGE STRUCTURE.

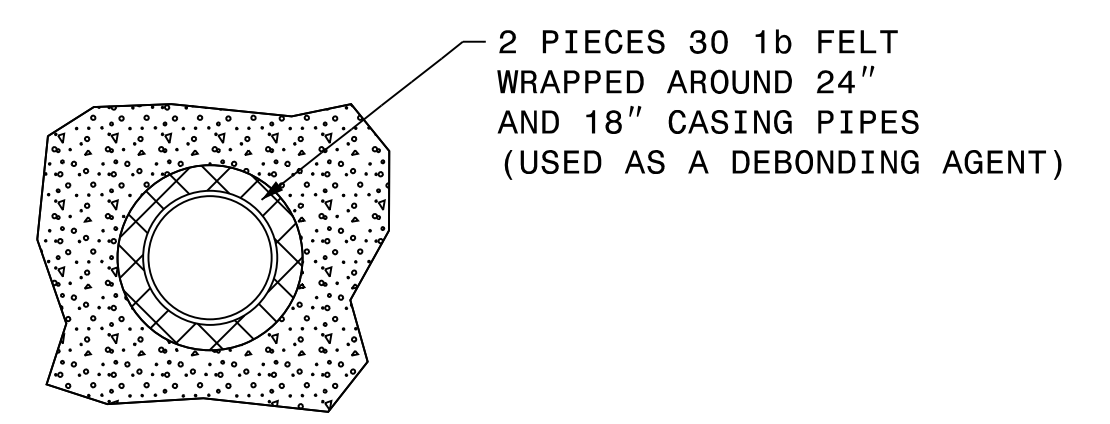

**DEBONDED DETAIL**

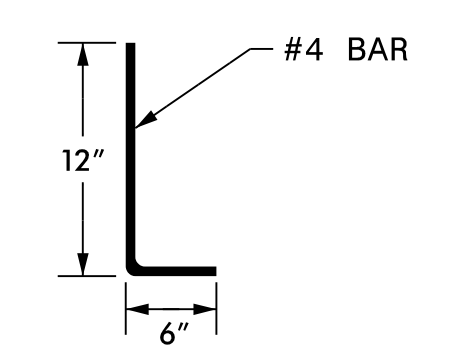

**DOWEL**

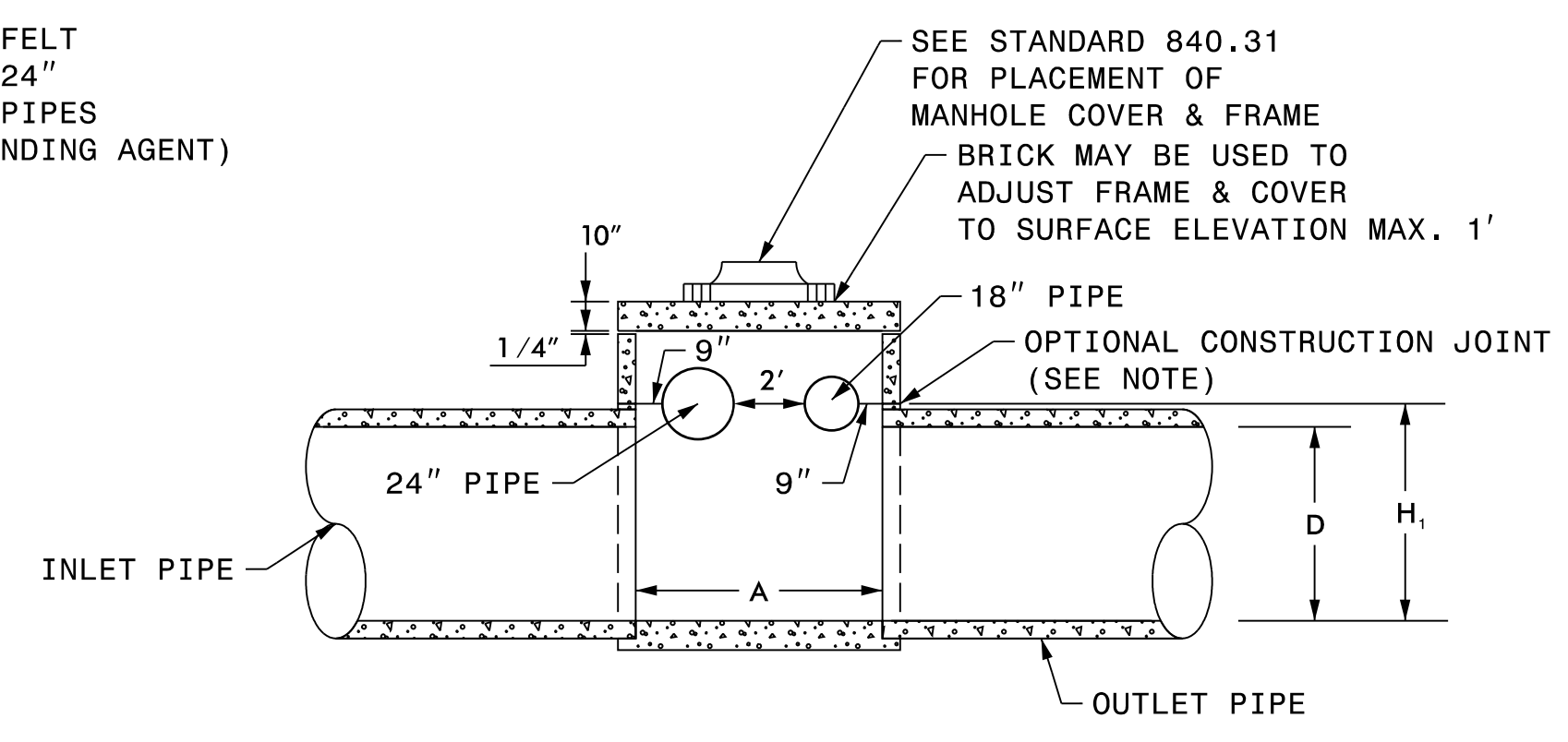

**SECTION X-X**

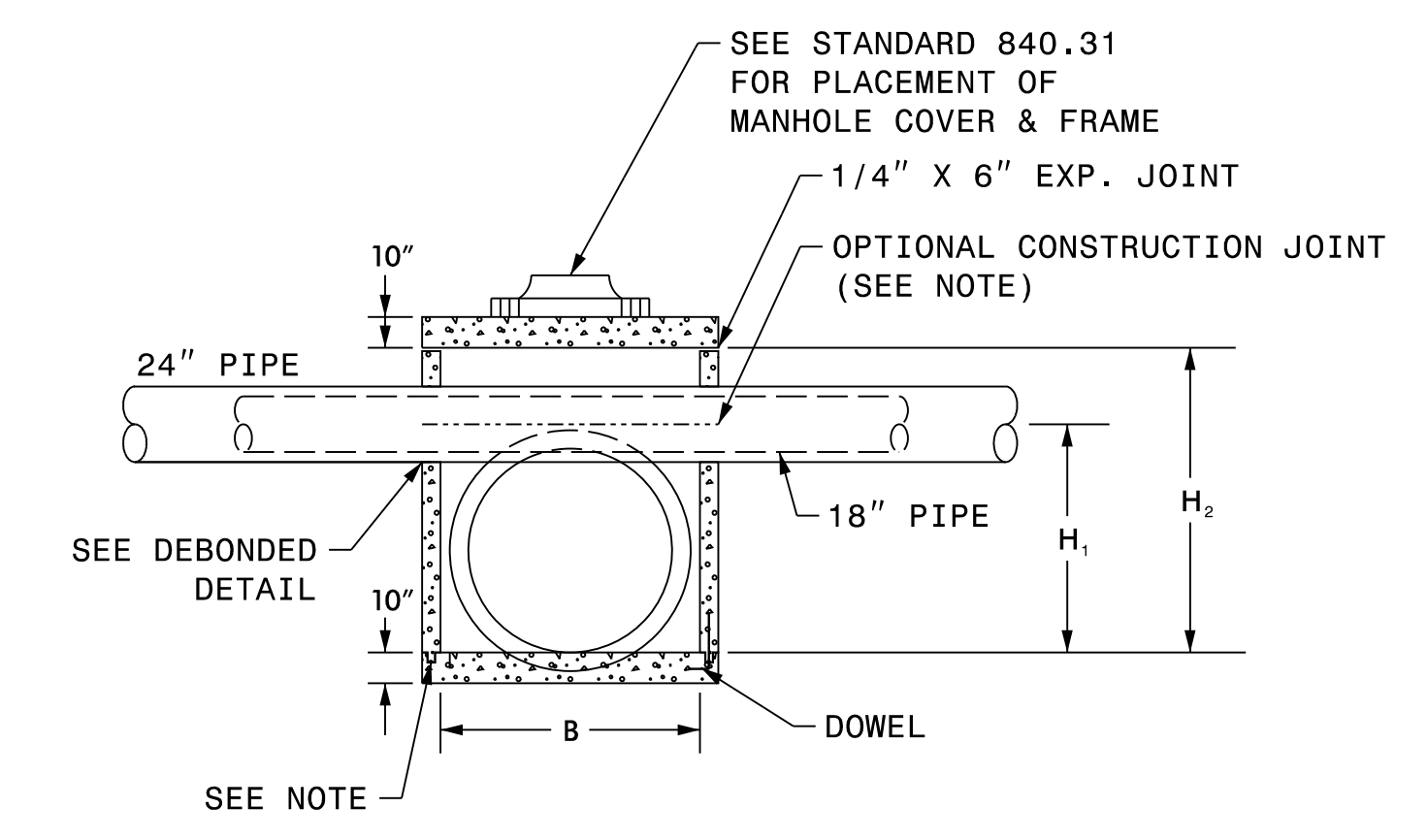

**SECTION Y-Y**

DIMENSIONS AND QUANTITIES FOR CONCRETE JUNCTION BOXES															
DIMENSIONS OF BOX AND PIPE					REINFORCEMENT BARS "A"		TOP SLAB (COVER) DIMENSIONS		CUBIC YARDS IN BOX			TOTAL QUANTITIES BOX AND SLABS		DEDUCTIONS FOR ONE PIPE (CU. YDS.)	
PIPE	SPAN	WIDTH	HEIGHT		NO.	LENGTH	E	F	TOP SLAB	BOTTOM SLAB	WALL/ FT. OF HT.	LBS. REINF.	CU YDS. MIN "H"	C.S.	R.C.
D	A	B	H <sub>1</sub>	H <sub>2</sub>											
66"	7' - 1"	7' - 1"	6' - 2"	8' - 6"	32	7' - 10"	8' - 1"	8' - 1"	1.389	1.389	0.518	183	7.45	0.444	0.655

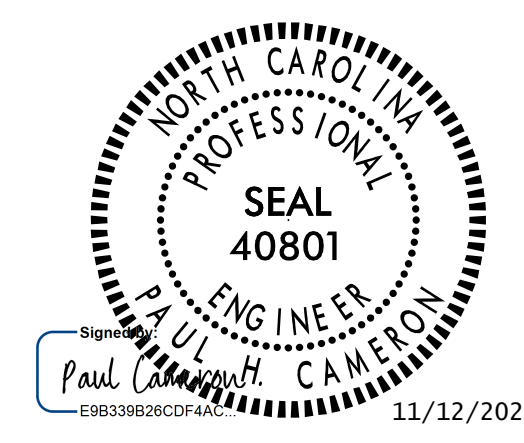

**DOCUMENT NOT CONSIDERED FINAL UNLESS ALL SIGNATURES COMPLETED**

**HNTB** HNTB NORTH CAROLINA, P.C.  
343 E. Six Forks Road, Suite 200  
Raleigh, North Carolina 27609  
NC License No: C-1554

**CONCRETE JUNCTION BOX WITH 24" PIPE AND 18" PIPE PASSING THRU**

ORIGINAL BY: P. CAMERON DATE: FEB. 2024  
 MODIFIED BY: DATE: \_\_\_\_\_  
 CHECKED BY: DATE: \_\_\_\_\_  
 FILE SPEC.: DATE: \_\_\_\_\_

### 18 CHANNEL CONFLICT MONITOR PROGRAMMING DETAIL

(remove jumpers and set switches as shown)

REMOVE DIODE JUMPERS 1-5, 1-6, 1-9, 1-11, 2-5, 2-6, 2-9, 2-11, 3-7, 3-8, 3-10, 3-12, 4-7, 4-8, 4-10, 4-12, 5-9, 5-11, 6-9, 6-11, 7-10, 7-12, 8-10, 8-12, 9-11, AND 10-12.

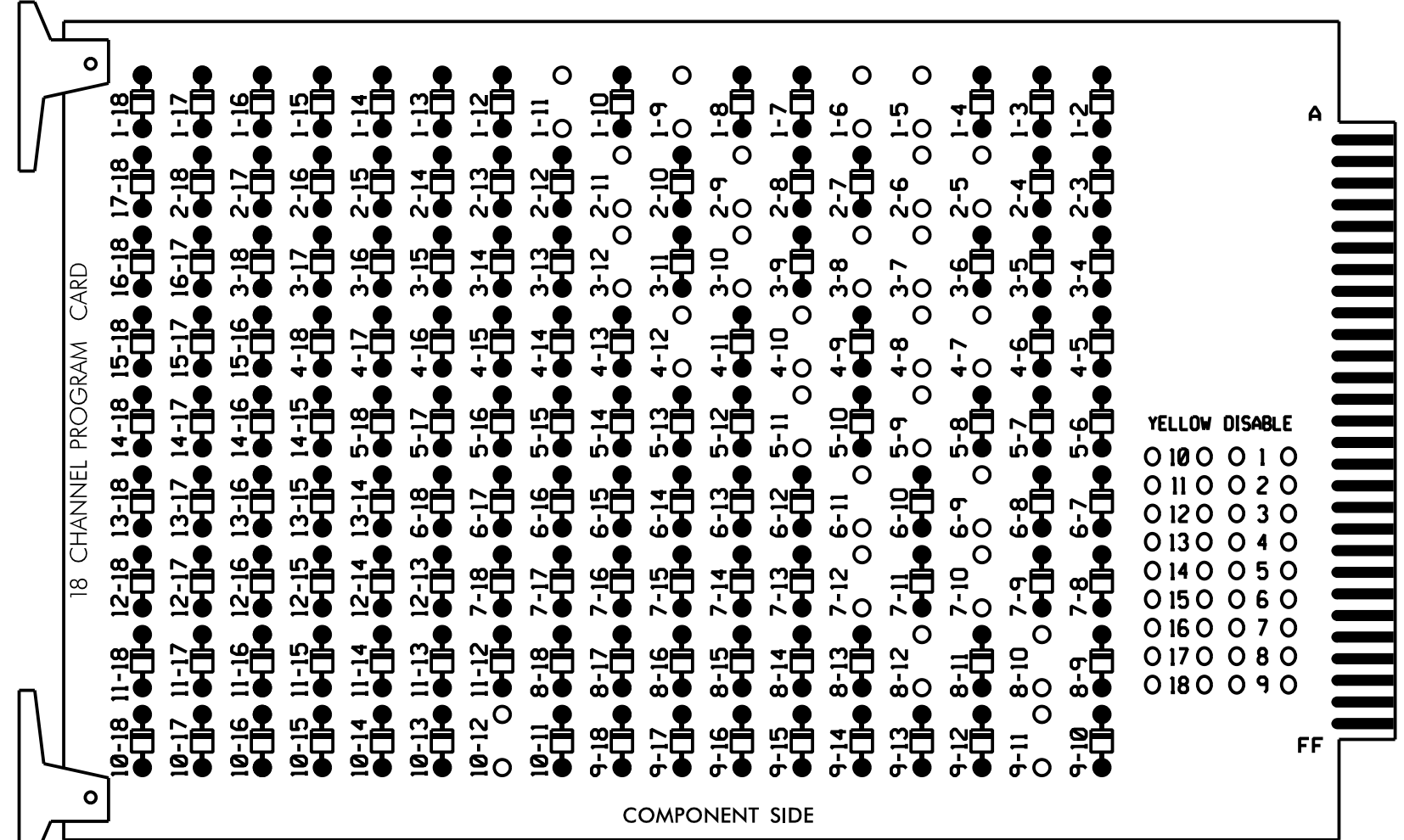

REMOVE JUMPERS AS SHOWN

#### NOTES:

- Card is provided with all diode jumpers in place. Removal of any jumper allows its channels to run concurrently.
- Ensure jumpers SEL2-SEL5 are present on the monitor board.
- Ensure that Red Enable is active at all times during normal operation.
- Connect serial cable from conflict monitor to comm. port 1 of 2070 controller. Ensure conflict monitor communicates with 2070.

■ = DENOTES POSITION OF SWITCH

### NOTES

- To prevent "flash-conflict" problems, insert red flash program blocks for all unused vehicle load switches in the output file. The installer shall verify that signal heads flash in accordance with the Signal Plans.
- Program phases 4 and 8 for Dual Entry.
- Enable Simultaneous Gap-Out for all Phases.
- Program phases 2 and 6 for Startup in Green.
- Program phases 2 and 6 for Yellow Flash, and overlaps 1 and 2 as Wag Overlaps.
- The cabinet and controller are part of the Wilmington Signal System.

### EQUIPMENT INFORMATION

CONTROLLER.....2070  
 CABINET.....332 W/ AUX  
 SOFTWARE.....ECONOLITE OASIS  
 CABINET MOUNT.....BASE  
 OUTPUT FILE POSITIONS...18 WITH AUX. OUTPUT FILE LOAD SWITCHES USED.....S1,S2,S3,\*S4,S5,S7,S8,\*S9,S10,S11,AUX S1,AUX S2,AUX S4,AUX S5  
 PHASES USED.....1,2,3,4,5,6,7,8  
 OVERLAP "A".....1+2  
 OVERLAP "B".....3+4  
 OVERLAP "C".....5+6  
 OVERLAP "D".....7+8

\* Used for Advanced Beacons

### SIGNAL HEAD HOOK-UP CHART

LOAD SWITCH NO.	S1	S2	S3	S4	S5	S6	S7	S8	S9	S10	S11	S12	AUX S1	AUX S2	AUX S3	AUX S4	AUX S5	AUX S6	
CMU CHANNEL NO.	1	2	13	3	4	14	5	6	15	7	8	16	9	10	17	11	12	18	
PHASE	1	2	2 PED	3	4	4 PED	5	6	6 PED	7	8	8 PED	OLA	OLB	SPARE	OLC	OLD	SPARE	
SIGNAL HEAD NO.	11	21,22	23,24	31	41,42	NU	42	51	61,62	25,26	62	71	81,82	NU	11	31	NU	51	71
RED		128			101		*		134		*		107						
YELLOW	*	129		*	102				135				108						
GREEN		130			103				136				109						
RED ARROW													A121	A124		A114	A101		
YELLOW ARROW							132			123			A122	A125		A115	A102		
FLASHING YELLOW ARROW													A123	A126		A116	A103		
GREEN ARROW	127			118			133	133		124	124								
PED YELLOW														** 120					

NU = Not Used

\* Denotes install load resistor. See load resistor installation detail this sheet.

\*\* Advance Beacons will be wired to S2P-Y and S6P-Y. See wiring and programming detail on sheet 2.

\* See pictorial of head wiring in detail this sheet.

### INPUT FILE POSITION LAYOUT

(front view)

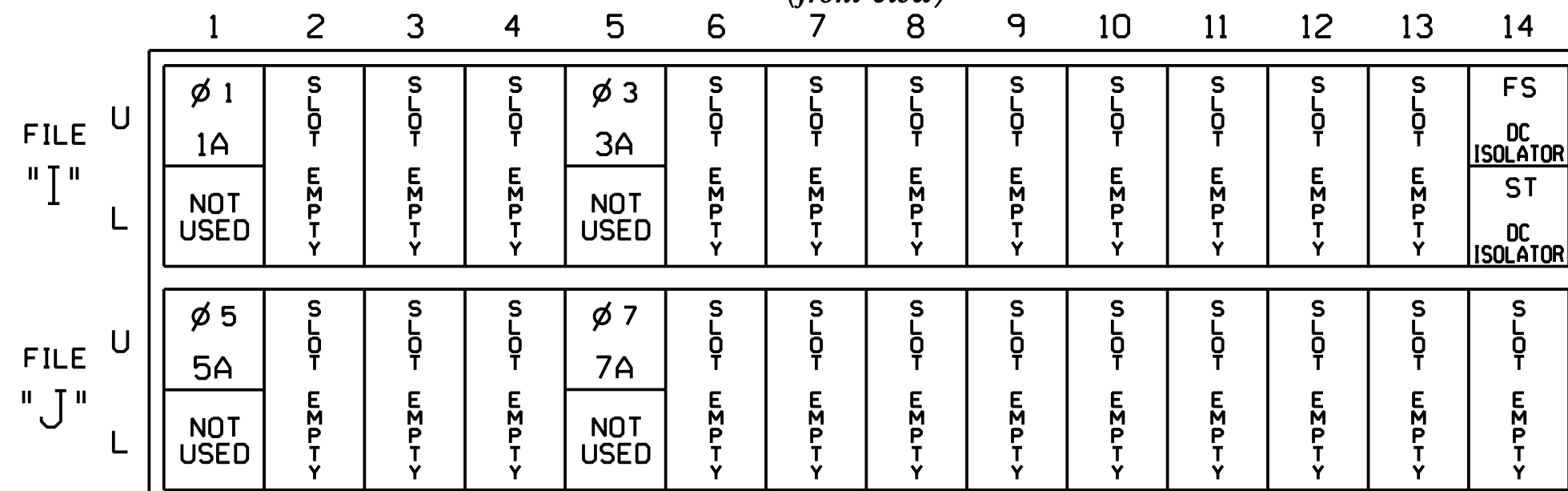

EX.: 1A, 2A, ETC. = LOOP NO.'S

FS = FLASH SENSE  
ST = STOP TIME

### SPECIAL DETECTOR NOTE

Install a multizone microwave detection system for vehicle detection. Perform installation according to manufacturer's directions and NCDOT engineer-approved mounting locations to accomplish detection schemes shown on the Signal Design Plans.

### LOAD RESISTOR INSTALLATION DETAIL

(install resistors as shown below)

VALUE (ohms)	WATTAGE
1.5K - 1.9K	25W (min)
2.0K - 3.0K	10W (min)

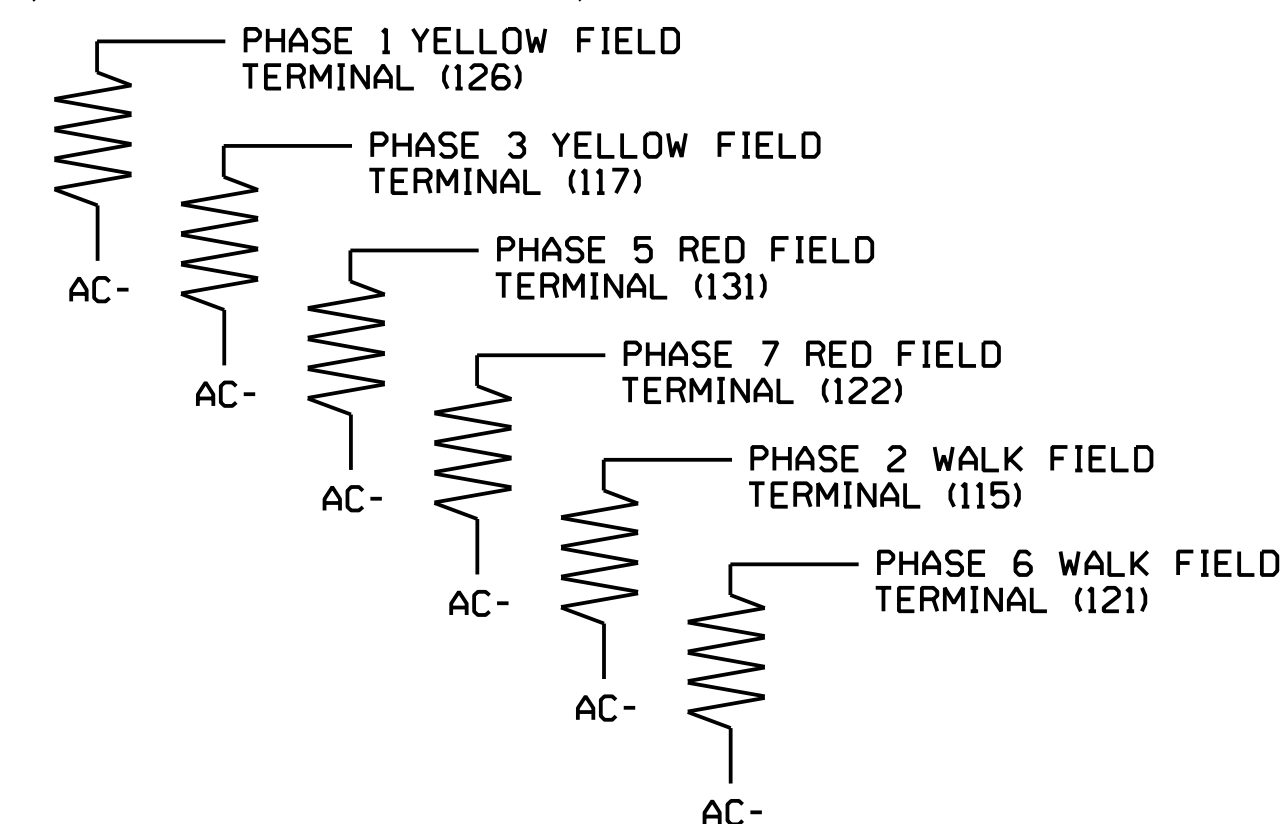

### INPUT FILE CONNECTION & PROGRAMMING CHART

LOOP NO.	LOOP TERMINAL	INPUT FILE POS.	PIN NO.	INPUT ASSIGNMENT NO.	DETECTOR NO.	NEMA PHASE	CALL	EXTEND	FULL TIME DELAY	STRETCH TIME	DELAY TIME
1A	TB2-1,2	I1U	56	18	1	1	Y	Y			15
	-	J4U	48	10*	26	6	Y	Y			
	-	I1U	56	18*	51	1	Y	Y			
3A	TB4-5,6	I5U	58	20	3	3	Y	Y			15
	-	J8U	50	12*	28	8	Y	Y			3
	-	I5U	58	20*	53	3	Y	Y			3
5A	TB3-1,2	J1U	55	17	5	5	Y	Y			15
	-	I4U	47	9*	22	2	Y	Y			
	-	J1U	55	17*	55	5	Y	Y			15
7A	TB5-5,6	J5U	57	19	7	7	Y	Y			15
	-	I8U	49	11*	24	4	Y	Y			
	-	J5U	57	19*	57	7	Y	Y			

\* See Input Page Assignment programming details on sheets 4, 5, 6, and 7.

INPUT FILE POSITION LEGEND: J2L

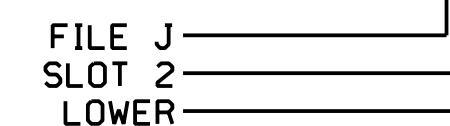

This plan supersedes the plan signed and sealed on 5/17/2024.

THIS ELECTRICAL DETAIL IS FOR THE SIGNAL DESIGN: 03-0331T1  
DESIGNED: May 2022  
SEALED: 5/17/2024  
REVISED:



HNTB NORTH CAROLINA, P.C.  
343 E. Six Forks Road, Suite 200  
Raleigh, North Carolina 27609  
NC License No: C-1554  
(919) 546-8997

### FYA SIGNAL WIRING DETAIL

(wire signal heads as shown)

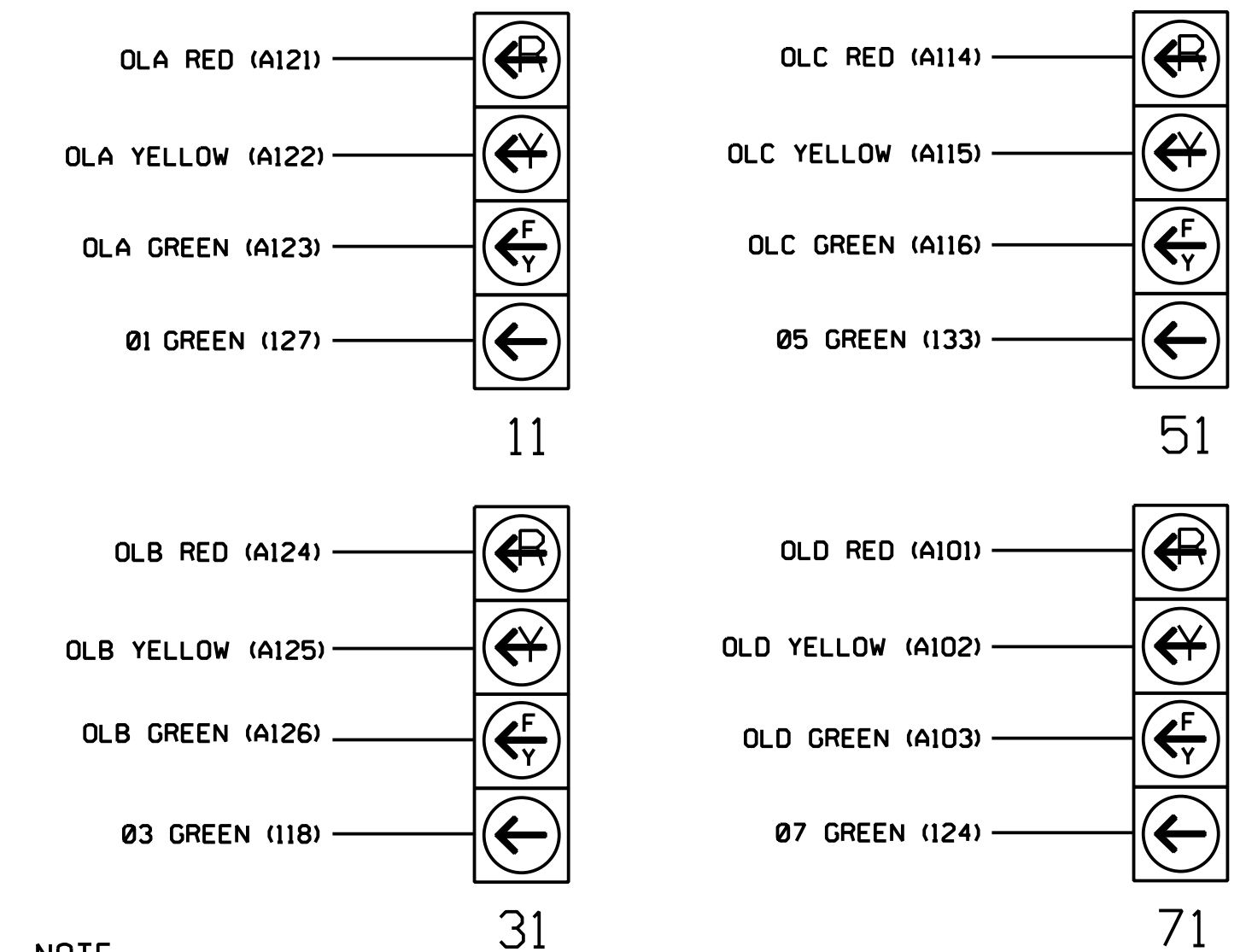

NOTE

The sequence display for signal heads 11, 31, 51, and 71 requires special logic programming. See sheet 3 for programming instructions.

Signal Upgrade-  
Electrical Detail - Sheet 1 of 8  
(Construction Phase 1)

DOCUMENT NOT CONSIDERED FINAL UNLESS ALL SIGNATURES COMPLETED

	ELECTRICAL AND PROGRAMMING DETAILS FOR: I-40 EB Ramp / US 117 - NC 132 (N. College Road) at SR 2048 (Gordon Rd)	SEAL NORTH CAROLINA PROFESSIONAL ENGINEER NATASHA R. SIMMONS
	Division 3 New Hanover County Wilmington PLAN DATE: August 2023 REVIEWED BY: N.K. Vlanich PREPARED BY: E.E. Tiller REVIEWED BY: N.R. Simmons	REVISIONS: _____ INITI: _____ DATE: _____ Signature: _____ DATE: 11/8/2024 Sig. Inventory No. 03-0331T1



### 18 CHANNEL CONFLICT MONITOR PROGRAMMING DETAIL

(remove jumpers and set switches as shown)

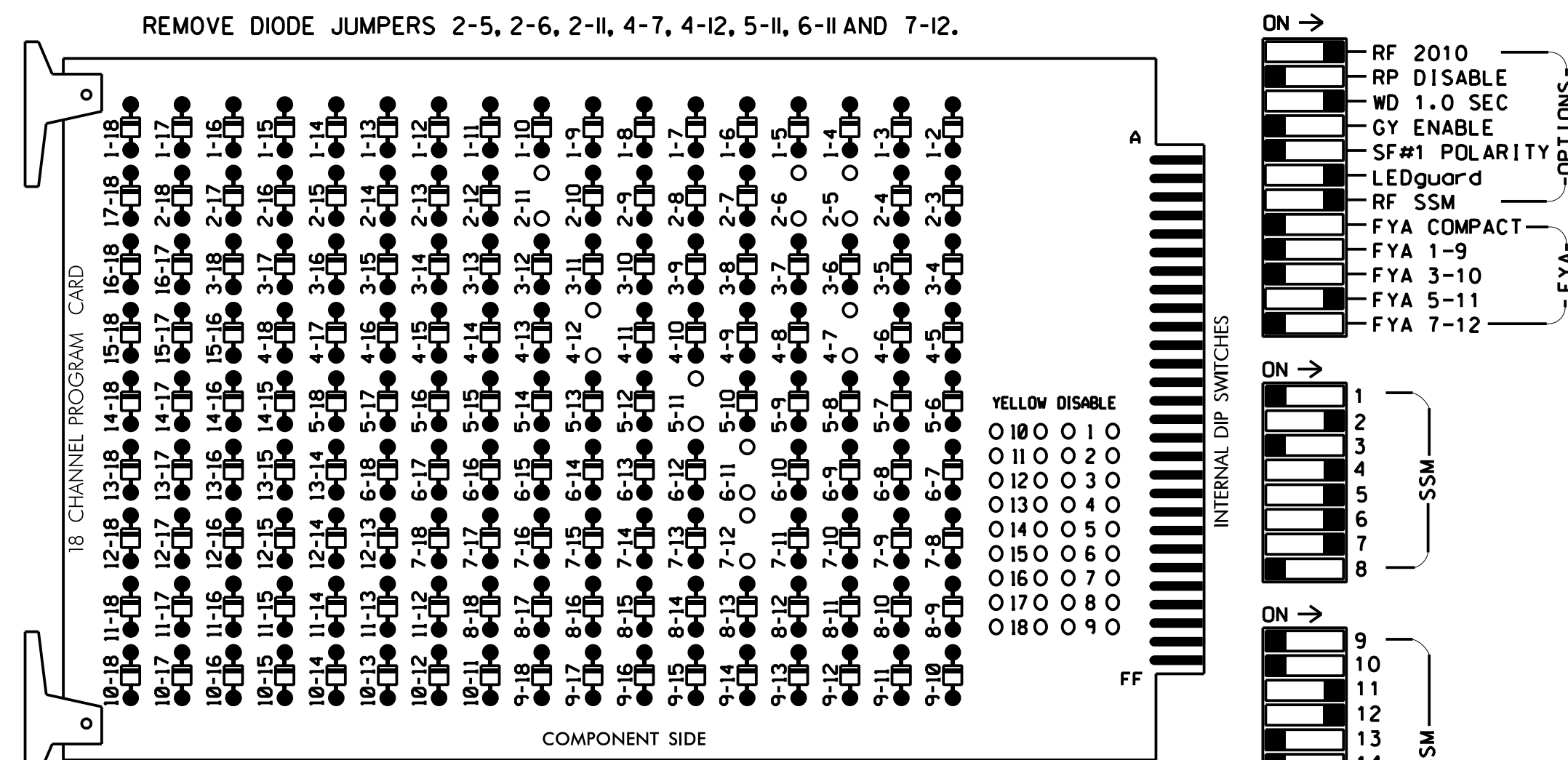

**NOTES:**

- Card is provided with all diode jumpers in place. Removal of any jumper allows its channels to run concurrently.
- Ensure jumpers SEL2-SEL5 are present on the monitor board.
- Ensure that Red Enable is active at all times during normal operation.
- Connect serial cable from conflict monitor to comm. port 1 of 2070 controller. Ensure conflict monitor communicates with 2070.

### NOTES

- To prevent "flash-conflict" problems, insert red flash program blocks for all unused vehicle load switches in the output file. The installer shall verify that signal heads flash in accordance with the Signal Plans.
- Return controller to Factory Defaults before programming per this electrical detail.
- Enable Simultaneous Gap-Out for all Phases.
- Program phases 2 and 6 for Startup in Green.
- Program phases 2 and 6 for Yellow Flash.
- The cabinet and controller are part of the Wilmington Signal System.

### EQUIPMENT INFORMATION

CONTROLLER.....2070  
 CABINET.....332 W/ AUX  
 SOFTWARE.....ECONOLITE OASIS  
 CABINET MOUNT.....BASE  
 OUTPUT FILE POSITIONS...18 WITH AUX. OUTPUT FILE  
 LOAD SWITCHES USED.....S1,S2,\*S3,S4,S5,S7,S8,\*S9,S10,  
 S11,AUX S1,AUX S2,AUX S4,AUX S5  
 PHASES USED.....2,4,5,6,7  
 OVERLAP "A".....NOT USED  
 OVERLAP "B".....NOT USED  
 OVERLAP "C".....5+6  
 OVERLAP "D".....7

\* Used for Advanced Beacons

### SIGNAL HEAD HOOK-UP CHART

LOAD SWITCH NO.	S1	S2	S3	S4	S5	S6	S7	S8	S9	S10	S11	S12	AUX S1	AUX S2	AUX S3	AUX S4	AUX S5	AUX S6	
CMU CHANNEL NO.	1	2	13	3	4	14	5	6	15	7	8	16	9	10	17	11	12	18	
PHASE	1	2	2 PED	3	4	4 PED	5	6	6 PED	7	8	8 PED	OLA	OLB	SPARE	OLC	OLD	SPARE	
SIGNAL HEAD NO.	11	21,22	23,24	31	41,42	NU	42	51	61,62	25,26	62	71	81,82	NU	11	31	NU	51	71
RED		128			101		*		134		*		107						
YELLOW	*	129		*	102				135				108						
GREEN		130			103				136				109						
RED ARROW													A121	A124		A114	A101		
YELLOW ARROW							132			123			A122	A125		A115	A102		
FLASHING YELLOW ARROW													A123	A126		A116	A103		
GREEN ARROW	127			118			133	133		124	124								
PED YELLOW													** 114						
													** 120						

NU = Not Used

\* Denotes install load resistor. See load resistor installation detail this sheet.

\*\* Advance Beacons will be wired to S2P-Y and S6P-Y. See wiring and programming detail on sheet 2.

\* See pictorial of head wiring in detail this sheet.

### INPUT FILE POSITION LAYOUT

(front view)

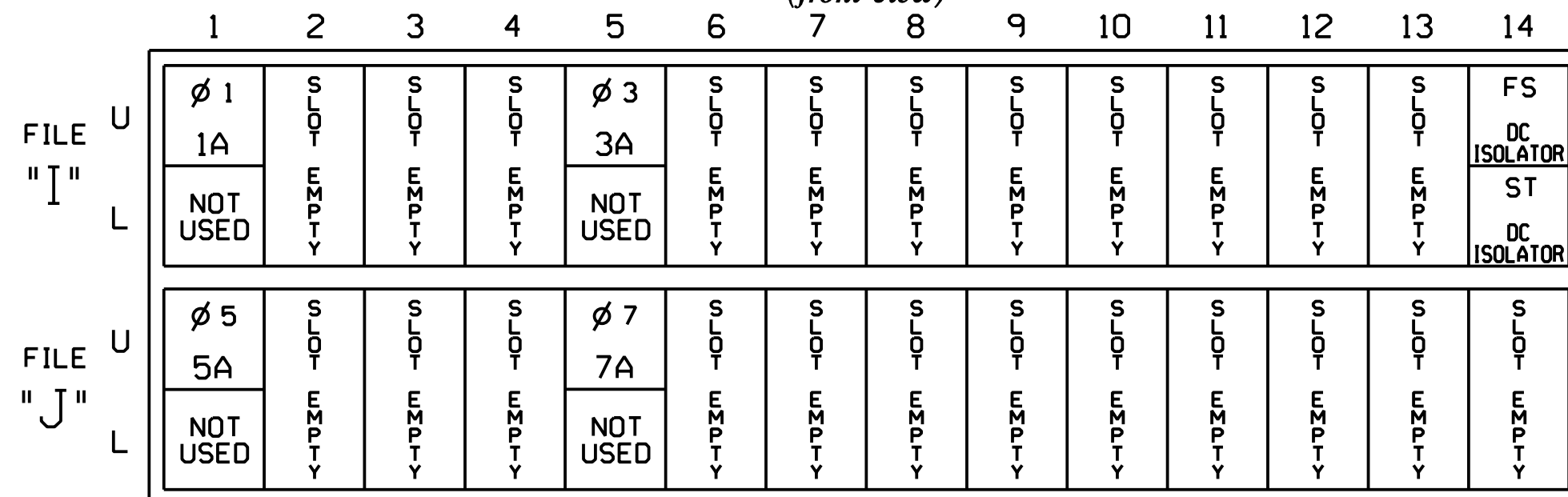

### SPECIAL DETECTOR NOTE

Install a multizone microwave detection system for vehicle detection. Perform installation according to manufacturer's directions and NCDOT engineer-approved mounting locations to accomplish detection schemes shown on the Signal Design Plans.

### INPUT FILE CONNECTION & PROGRAMMING CHART

LOOP NO.	LOOP TERMINAL	INPUT FILE POS.	PIN NO.	INPUT ASSIGNMENT NO.	DETECTOR NO.	NEMA PHASE	CALL	EXTEND	FULL TIME DELAY	STRETCH TIME	DELAY TIME
1A	TB2-1,2	I1U	56	18	1	1	Y	Y			15
	-	J4U	48	10*	26	6	Y	Y			
	-	I1U	56	18*	51	1	Y	Y			
3A	TB4-5,6	I5U	58	20	3	3	Y	Y			15
	-	J8U	50	12*	28	8	Y	Y			
	-	I5U	58	20*	53	3	Y	Y			
5A	TB3-1,2	J1U	55	17	5	5	Y	Y			15
	-	I4U	47	9*	22	2	Y	Y			
	-	J1U	55	17*	55	5	Y	Y			
7A	TB5-5,6	J5U	57	19	7	7	Y	Y			15
	-	I8U	49	11*	24	4	Y	Y			
	-	J5U	57	19*	57	7	Y	Y			

\* See Input Page Assignment programming details on sheets 4, 5, 6, and 7.

### INPUT FILE POSITION LEGEND: J2L

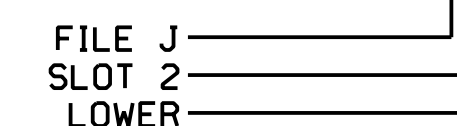

### LOAD RESISTOR INSTALLATION DETAIL

(install resistors as shown below)

VALUE (ohms)	WATTAGE
1.5K - 1.9K	25W (min)
2.0K - 3.0K	10W (min)

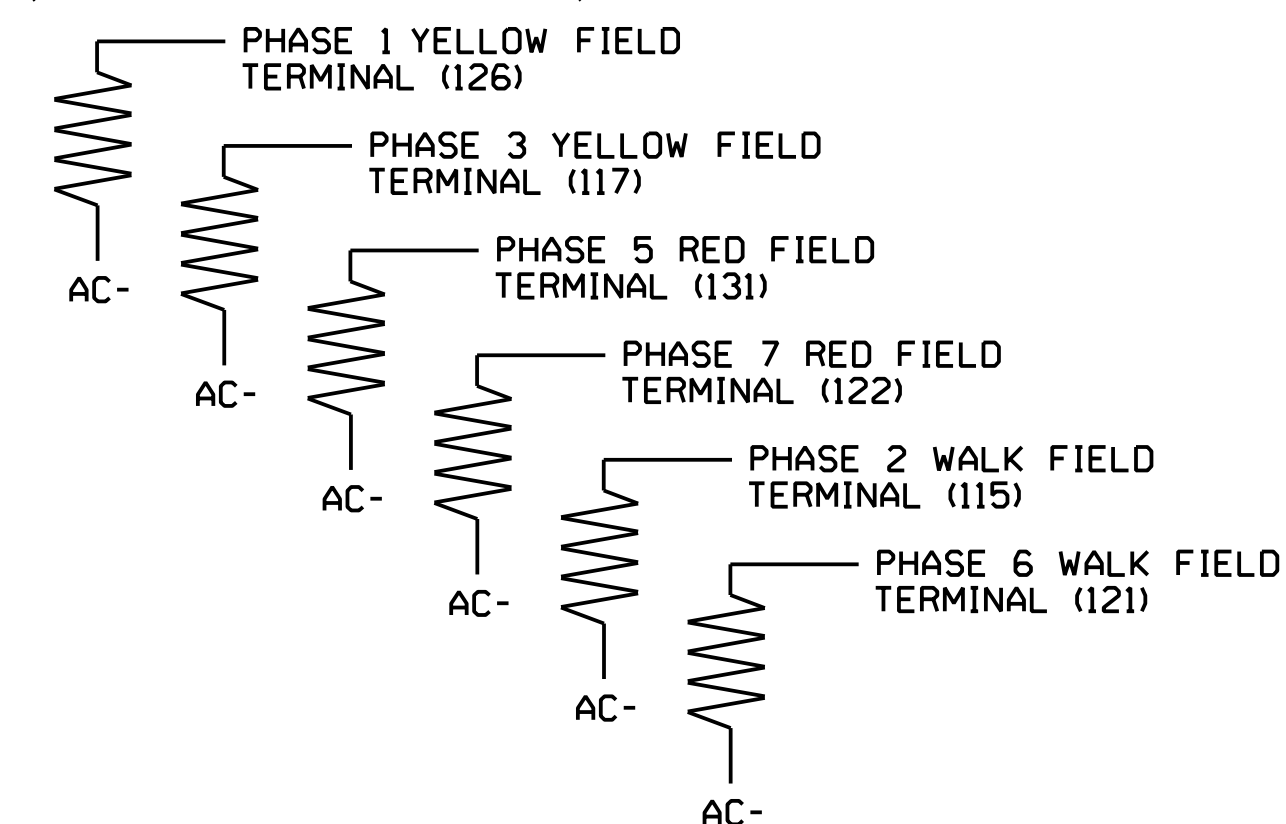

THIS ELECTRICAL DETAIL IS FOR THE SIGNAL DESIGN: 03-0331T2  
 DESIGNED: May 2022  
 SEALED: 5/17/2024  
 REVISED:

This plan supersedes the plan signed and sealed on 5/17/2024.



HNTB NORTH CAROLINA, P.C.  
 343 E. Six Forks Road, Suite 200  
 Raleigh, North Carolina 27609  
 NC License No: C-1554  
 (919) 546-8997

### FYA SIGNAL WIRING DETAIL

(wire signal heads as shown)

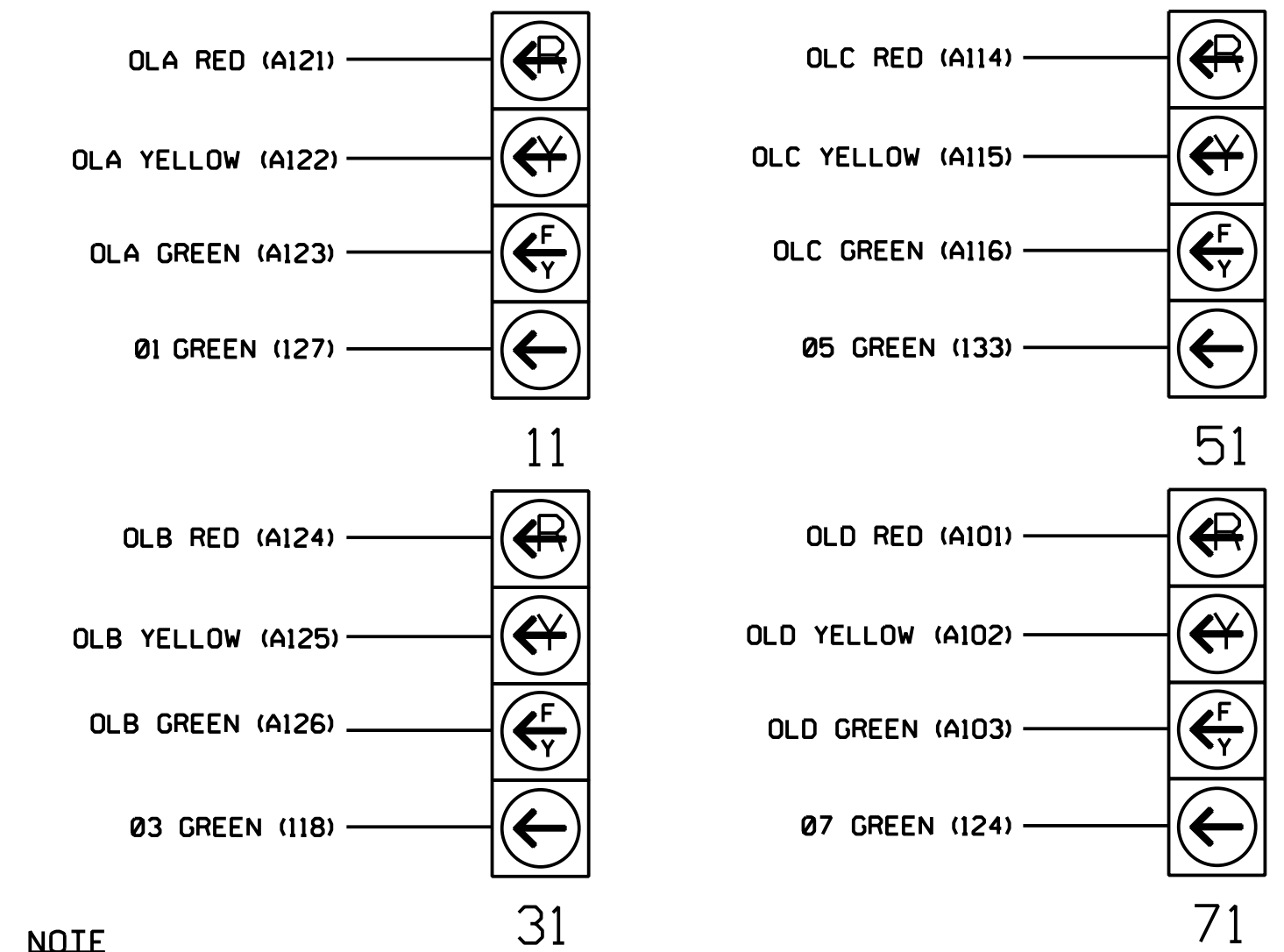

**NOTE**

The sequence display for signal heads 11, 31, 51, and 71 requires special logic programming. See sheet 3 for programming instructions.

Signal Upgrade-  
 Electrical Detail - Sheet 1 of 5  
 (Construction Phase 1, Step 2D)

DOCUMENT NOT CONSIDERED FINAL UNLESS ALL SIGNATURES COMPLETED

ELECTRICAL AND PROGRAMMING DETAILS FOR: Prepared in the Offices of:  750 N. Greenfield Pkwy, Garner, NC 27529	I-40 EB Ramp / US 117 - NC 132 (N. College Road) at SR 2048 (Gordon Rd)		SEAL NORTH CAROLINA PROFESSIONAL ENGINEER SEAL 031464 NATASHA R. SIMMONS
	Division 3 New Hanover County Wilmington PLAN DATE: August 2023 PREPARED BY: E.E. Tiller	REVIEWED BY: N.K. Vlanich REVIEWED BY: N.R. Simmons	



### 18 CHANNEL CONFLICT MONITOR PROGRAMMING DETAIL

(remove jumpers and set switches as shown)

REMOVE DIODE JUMPERS 1-5, 1-6, 1-9, 2-5, 2-6, 2-9, 3-7, 3-8, 3-10, 4-7, 4-8, 4-10, 5-9, 6-9, 7-10, AND 8-10.

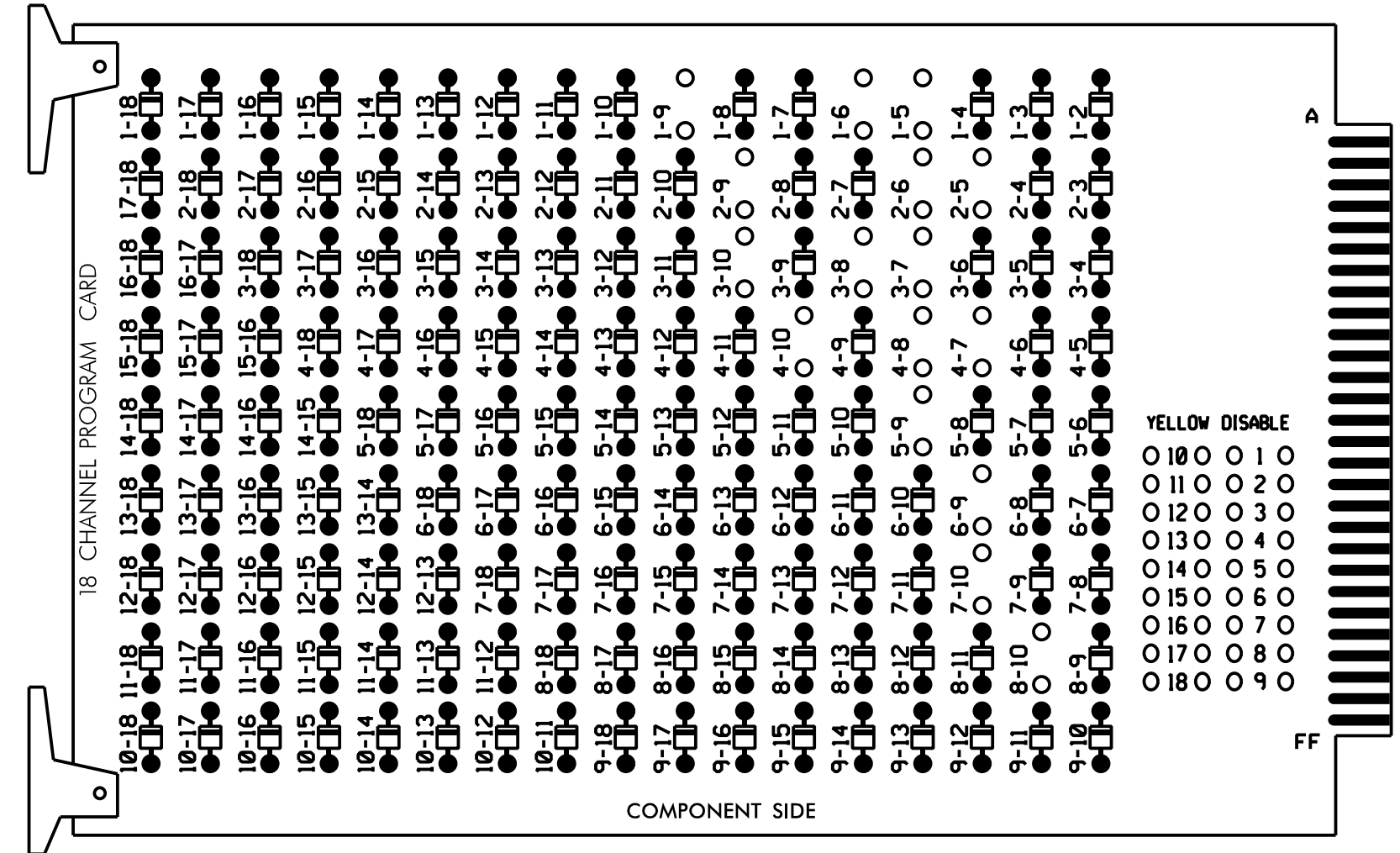

REMOVE JUMPERS AS SHOWN

NOTES:

- 1. Card is provided with all diode jumpers in place. Removal of any jumper allows its channels to run concurrently.
2. Ensure jumpers SEL2-SEL5 are present on the monitor board.
3. Ensure that Red Enable is active at all times during normal operation.
4. Connect serial cable from conflict monitor to comm. port 1 of 2070 controller. Ensure conflict monitor communicates with 2070.

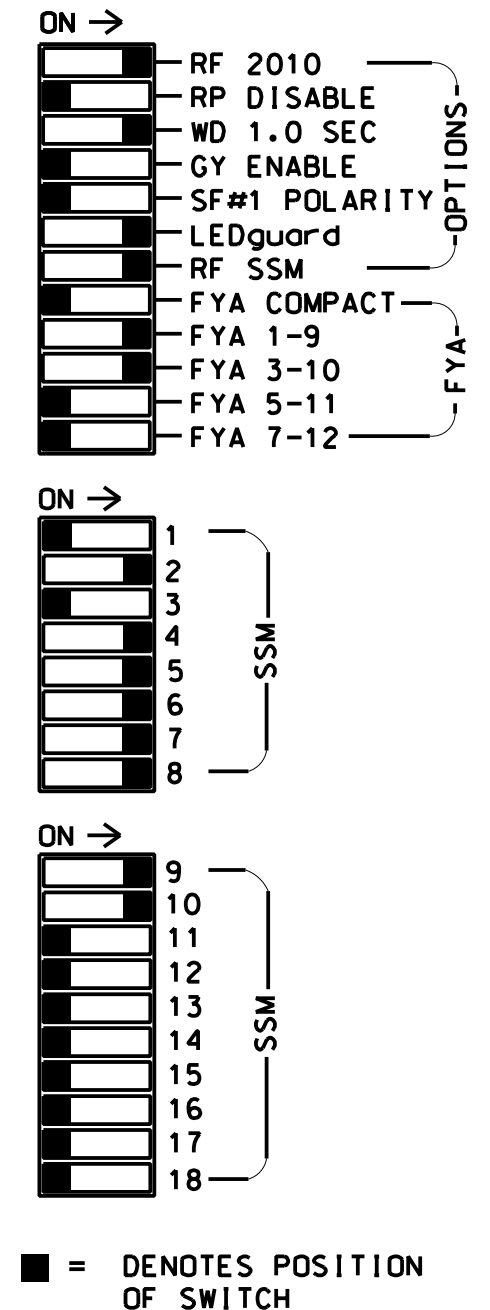
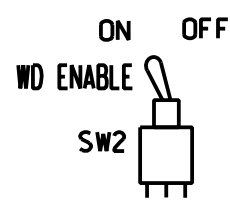

### NOTES

- 1. To prevent "flash-conflict" problems, insert red flash program blocks for all unused vehicle load switches in the output file. The installer shall verify that signal heads flash in accordance with the Signal Plans.
2. Return controller to Factory Defaults before programming per this electrical detail.
3. Program phases 4 and 8 for Dual Entry.
4. Enable Simultaneous Gap-Out for all Phases.
5. Program phases 2 and 6 for Startup in Green.
6. Program phases 2 and 6 for Yellow Flash, and overlaps 1 and 2 as Wag Overlaps.
7. The cabinet and controller are part of the Wilmington Signal System.

### EQUIPMENT INFORMATION

CONTROLLER.....2070
CABINET.....332 W/ AUX
SOFTWARE.....ECONOLITE OASIS
CABINET MOUNT.....BASE
OUTPUT FILE POSITIONS...18 WITH AUX. OUTPUT FILE LOAD SWITCHES USED.....S1,S2,\*S3,S4,S5,S7,S8,\*S9,S10,S11,AUX S1,AUX S2
PHASES USED.....1,2,3,4,5,6,7,8
OVERLAP "A".....1+2
OVERLAP "B".....3+4
OVERLAP "C".....NOT USED
OVERLAP "D".....NOT USED
\* Used for Advanced Beacons

### SIGNAL HEAD HOOK-UP CHART

Table with columns for Load Switch No., CMU Channel No., Phase, Signal Head No., and various signal head types (RED, YELLOW, GREEN, RED ARROW, YELLOW ARROW, FLASHING YELLOW ARROW, GREEN ARROW, PED YELLOW).

NU = Not Used
\* Denotes install load resistor. See load resistor installation detail this sheet.
\*\* Advance Beacons will be wired to S2P-Y and S6P-Y. See wiring and programming detail on sheet 2.
\* See pictorial of head wiring in detail this sheet.

### INPUT FILE POSITION LAYOUT

(front view)

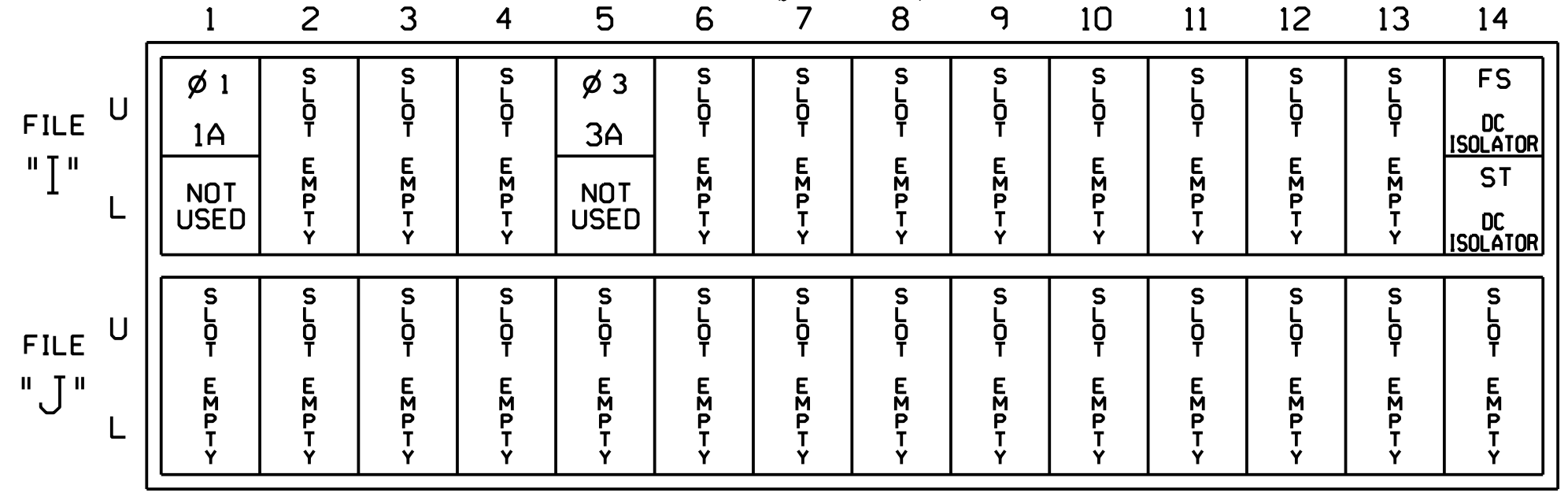

EX.: 1A, 2A, ETC. = LOOP NO.'S

FS = FLASH SENSE
ST = STOP TIME

### SPECIAL DETECTOR NOTE

Install a multizone microwave detection system for vehicle detection. Perform installation according to manufacturer's directions and NCDOT engineer-approved mounting locations to accomplish detection schemes shown on the Signal Design Plans.

### LOAD RESISTOR INSTALLATION DETAIL

(install resistors as shown below)

Table with columns: VALUE (ohms), WATTAGE. Values: 1.5K - 1.9K, 25W (min); 2.0K - 3.0K, 10W (min).

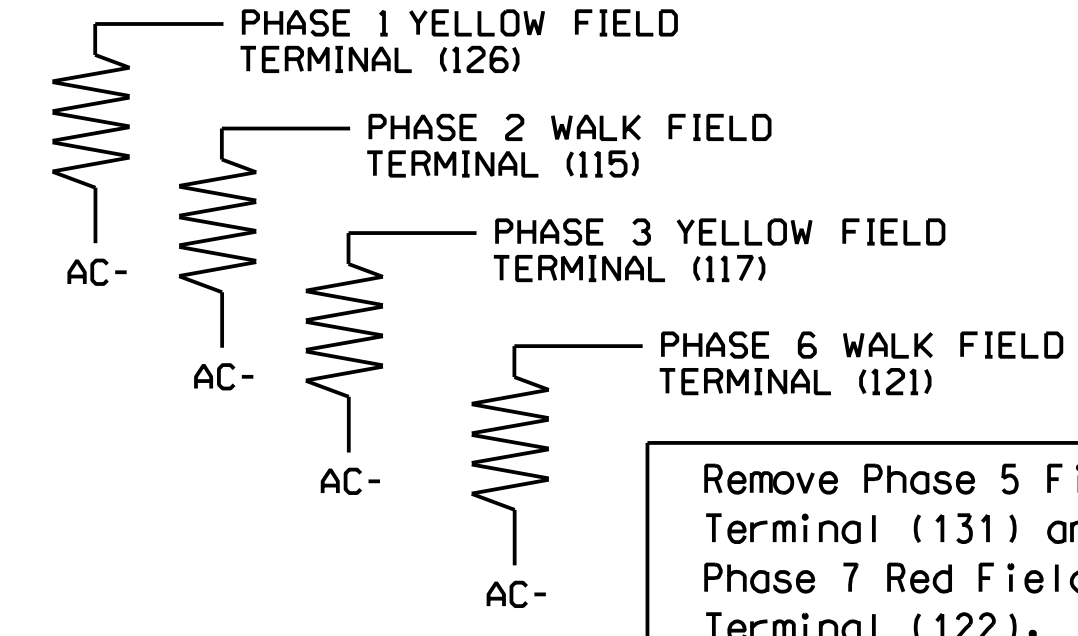

Remove Phase 5 Field Terminal (131) and Phase 7 Red Field Terminal (122), if present

### INPUT FILE CONNECTION & PROGRAMMING CHART

Table with columns: LOOP NO., LOOP TERMINAL, INPUT FILE POS., PIN NO., INPUT ASSIGNMENT NO., DETECTOR NO., NEMA PHASE, CALL, EXTEND, FULL TIME DELAY, STRETCH TIME, DELAY TIME.

\* See Input Page Assignment programming details on sheets 4 and 5.

### INPUT FILE POSITION LEGEND: J2L

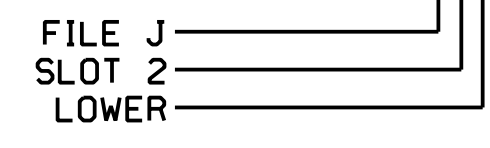

### FYA SIGNAL WIRING DETAIL

(wire signal heads as shown)

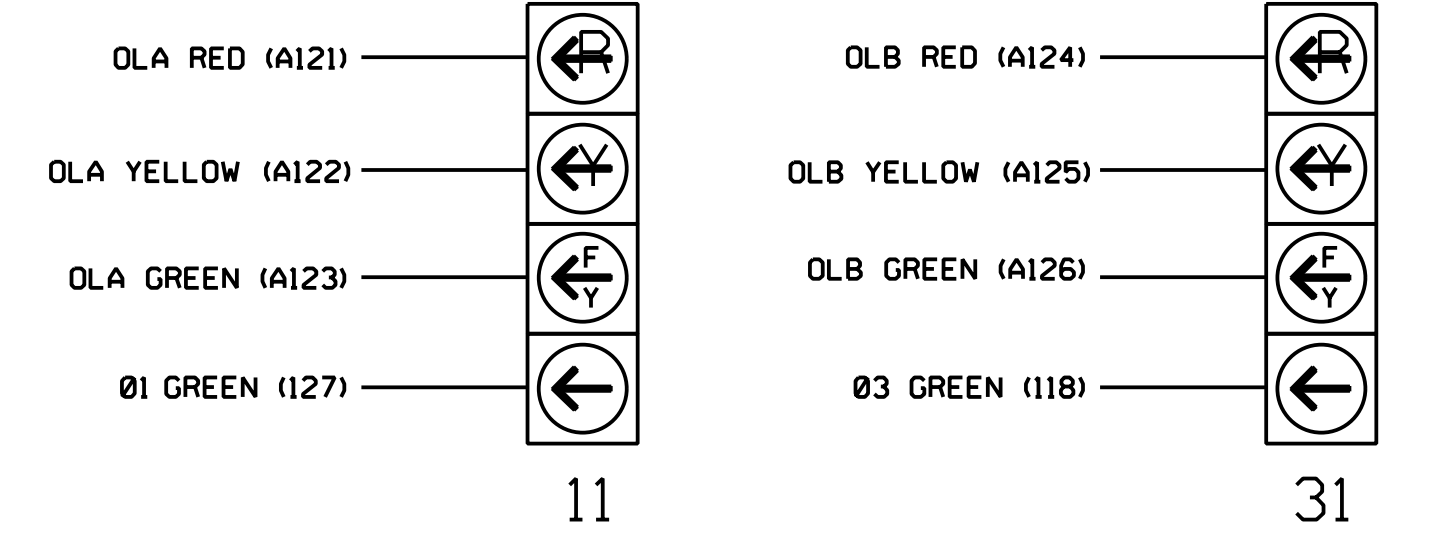

### NOTE

The sequence display for signal heads 11 and 31 require special logic programming. See sheet 3 for programming instructions.

Signal Upgrade- Electrical Detail - Sheet 1 of 6 (Construction Phase 2)

DOCUMENT NOT CONSIDERED FINAL UNLESS ALL SIGNATURES COMPLETED

THIS ELECTRICAL DETAIL IS FOR THE SIGNAL DESIGN: 03-0331T3 DESIGNED: May 2022 SEALED: 5/17/2024 REVISED:

This plan supersedes the plan signed and sealed on 5/17/2024.

HNTB HNTB NORTH CAROLINA, P.C. 343 E. Six Forks Road, Suite 200 Raleigh, North Carolina 27609 NC License No: C-1554 (919) 546-8997

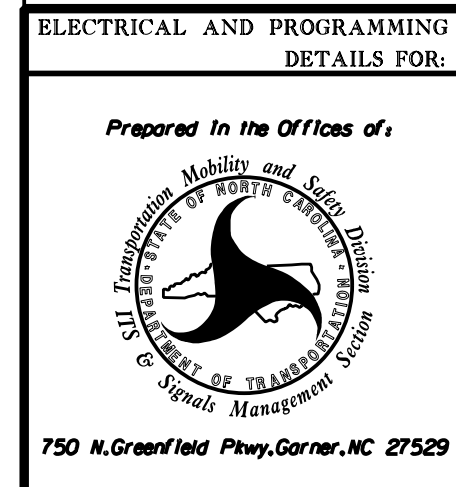

Electrical and Programming Details for: I-40 EB Ramp / US 117 - NC 132 (N. College Road) at SR 2048 (Gordon Rd) Division 3 New Hanover County Wilmington

Signature and Date fields for E.E. Tiller and N.R. Simmons.



### 18 CHANNEL CONFLICT MONITOR PROGRAMMING DETAIL

(remove jumpers and set switches as shown)

REMOVE DIODE JUMPERS 1-5, 1-6, 1-9, 1-15, 1-12, 1-17, 2-5, 2-6, 2-9, 2-12, 2-15, 2-17, 3-7, 3-8, 3-10, 3-17, 4-7, 4-8, 4-10, 4-12, 4-14, 4-17, 5-9, 5-12, 6-9, 6-15, 6-17, 7-10, 7-12, 7-14, 7-17, 8-10, 8-12, 8-14, 9-12, 9-15, 9-17, 10-12, 10-14, 10-17, 12-14, 12-17, 14-17 AND 15-17.

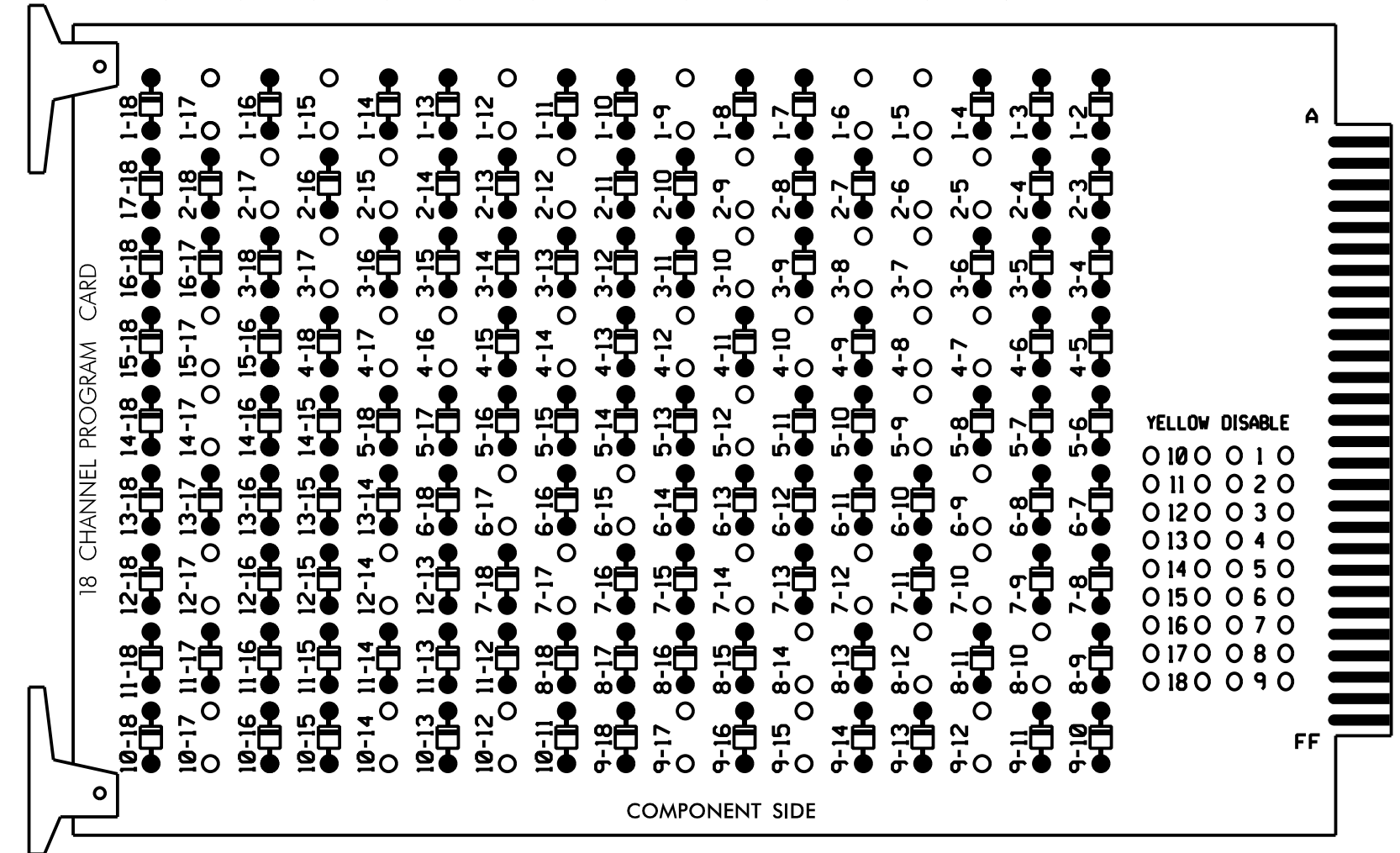

REMOVE JUMPERS AS SHOWN

**NOTES:**

- Card is provided with all diode jumpers in place. Removal of any jumper allows its channels to run concurrently.
- Ensure jumpers SEL2-SEL5 are present on the monitor board.
- Ensure that Red Enable is active at all times during normal operation.
- Connect serial cable from conflict monitor to comm. port 1 of 2070 controller. Ensure conflict monitor communicates with 2070.

■ = DENOTES POSITION OF SWITCH

### NOTES

- To prevent "flash-conflict" problems, insert red flash program blocks for all unused vehicle load switches in the output file. The installer shall verify that signal heads flash in accordance with the Signal Plans.
- Program phases 4 and 8 for Dual Entry.
- Enable Simultaneous Gap-Out for all Phases.
- Program phases 2 and 6 for Startup in Green.
- Program phases 2 and 6 for Yellow Flash, and overlaps 1, 2, and 5 as Wag Overlaps.
- The cabinet and controller are part of the Wilmington Signal System.

### EQUIPMENT INFORMATION

CONTROLLER.....2070  
 CABINET.....332 W/ AUX  
 SOFTWARE.....ECONOLITE OASIS  
 CABINET MOUNT.....BASE  
 OUTPUT FILE POSITIONS...18 WITH AUX. OUTPUT FILE LOAD SWITCHES USED.....S1,S2,\*S3,S4,S5,S6,S7,S8,S9,S10,S11,AUX S1,AUX S2,AUX S3,AUX S5  
 PHASES USED.....1,2,3,4,4 PED,5,6,6 PED,7,8  
 OVERLAP "A".....1+2  
 OVERLAP "B".....3+4  
 OVERLAP "C".....NOT USED  
 OVERLAP "D".....4+5  
 OVERLAP "E".....6+7  
 OVERLAP "F".....NOT USED

\* Used for Advanced Beacons

### SIGNAL HEAD HOOK-UP CHART

LOAD SWITCH NO.	S1	S2	S3	S4	S5	S6	S7	S8	S9	S10	S11	S12	AUX S1	AUX S2	AUX S3	AUX S4	AUX S5	AUX S6	
CMU CHANNEL NO.	1	2	13	3	4	14	5	6	15	7	8	16	9	10	17	11	12	18	
PHASE	1	2	2 PED	3	4	4 PED	5	6	6 PED	7	8	8 PED	OLA	OLB	OLE	OLC	OLD	SPARE	
SIGNAL HEAD NO.	11	21,22	23,24	31	41,42	P41,P42	51,52	61,62	P61,P62	25,26	71,72	81,82	NU	11	31	63	NU	43	NU
RED		128			101			134				107				A111			
YELLOW	*	129		*	102			135				108							
GREEN		130			103			136				109							
RED ARROW								131				122			A121	A124		A101	
YELLOW ARROW								132				123			A122	A125	A112	A102	
FLASHING YELLOW ARROW															A123	A126	A113	A103	
GREEN ARROW	127			118				133				124							
PED YELLOW								104			119				* * 114			* * 120	

NU = Not Used  
 \* Denotes install load resistor. See load resistor installation detail this sheet.  
 \* Advance Beacons will be wired to S2P-Y and S6P-Y. See wiring and programming detail on sheet 2.  
 \* See pictorial of head wiring in detail this sheet.  
 NOTE: Load switch AUX S3 requires output remapping. See Sheet 7 of this electrical detail for instructions.

### INPUT FILE POSITION LAYOUT

(front view)

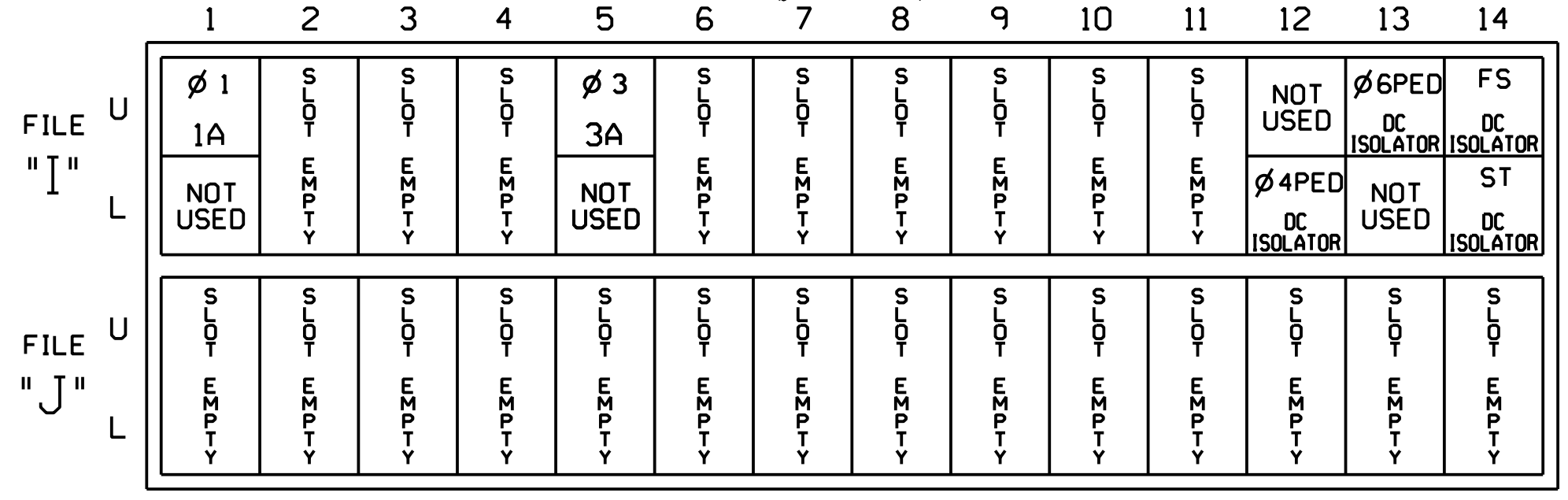

EX.: 1A, 2A, ETC. = LOOP NO.'S

FS = FLASH SENSE  
 ST = STOP TIME

### SPECIAL DETECTOR NOTE

Install a multizone microwave detection system for vehicle detection. Perform installation according to manufacturer's directions and NCDOT engineer-approved mounting locations to accomplish detection schemes shown on the Signal Design Plans.

### INPUT FILE CONNECTION & PROGRAMMING CHART

LOOP NO.	LOOP TERMINAL	INPUT FILE POS.	PIN NO.	INPUT ASSIGNMENT NO.	DETECTOR NO.	NEMA PHASE	CALL	EXTEND	FULL TIME DELAY	STRETCH TIME	DELAY TIME
1A	TB2-1,2	I1U	56	18	1	1	Y	Y			15
	-	J4U	48	10*	26	6	Y	Y			
	-	I1U	56	18*	51	1	Y	Y			
3A	TB4-5,6	I5U	58	20	3	3	Y	Y			15
	-	J8U	50	12*	28	8	Y	Y			3
	-	I5U	58	20*	53	3	Y	Y			3
PED PUSH BUTTONS											
P41,P42	TB8-5,6	I12L	69	31	PED 4	4 PED					
P61,P62	TB8-7,9	I13U	68	30	PED 6	6 PED					

NOTE:  
 INSTALL DC ISOLATORS IN INPUT FILE SLOTS 112 AND 113.

\* See Input Page Assignment programming details on sheets 4 and 5.

### INPUT FILE POSITION LEGEND: J2L

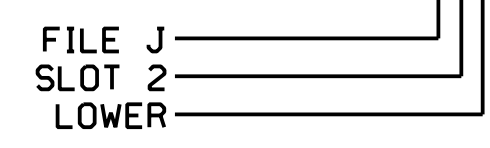

### FYA SIGNAL WIRING DETAIL

(wire signal heads as shown)

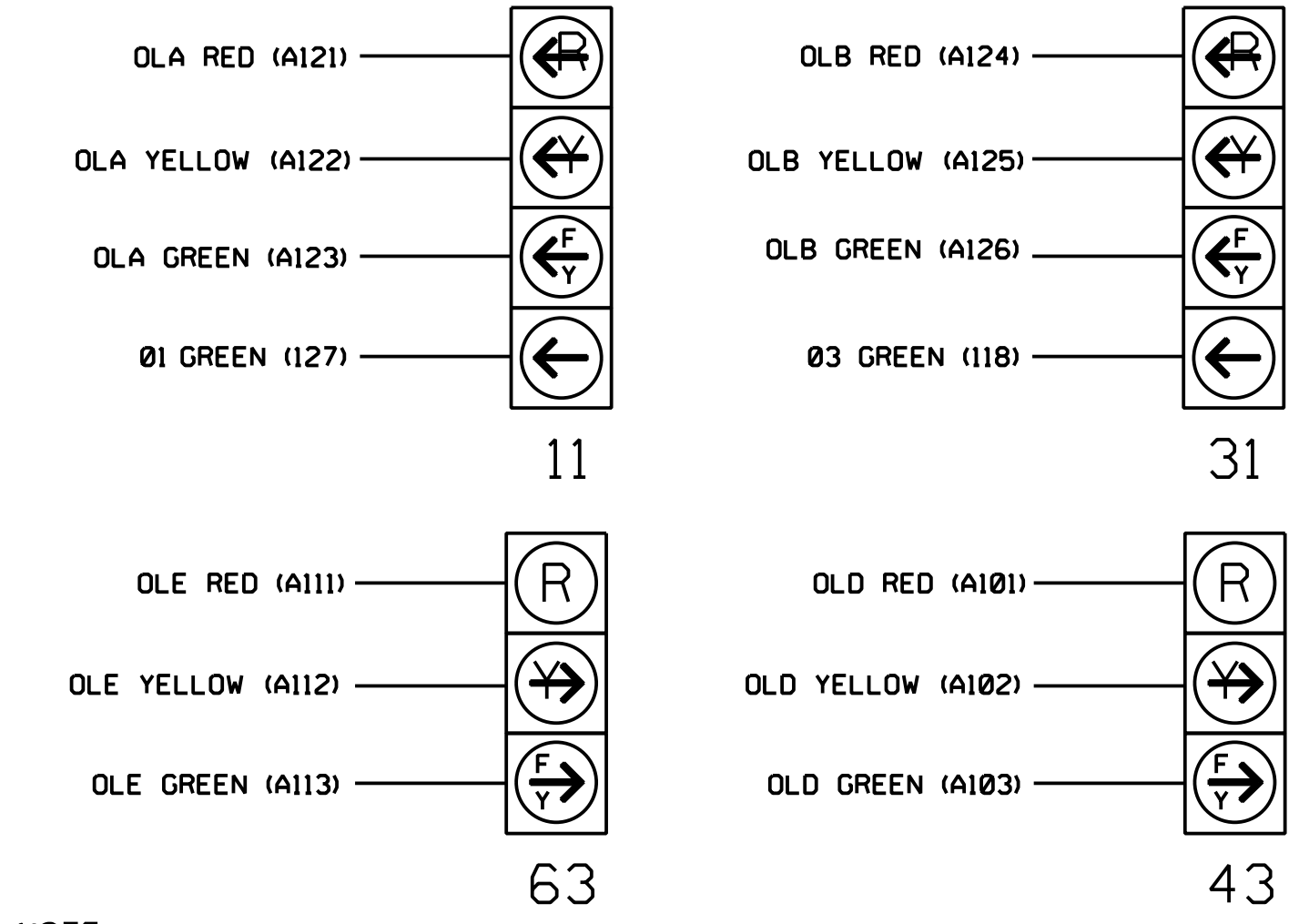

**NOTE**

The sequence display for signal heads 11 and 31 require special logic programming. See sheet 3 for programming instructions.

### LOAD RESISTOR INSTALLATION DETAIL

(install resistors as shown below)

VALUE (ohms)	WATTAGE
1.5K - 1.9K	25W (min)
2.0K - 3.0K	10W (min)

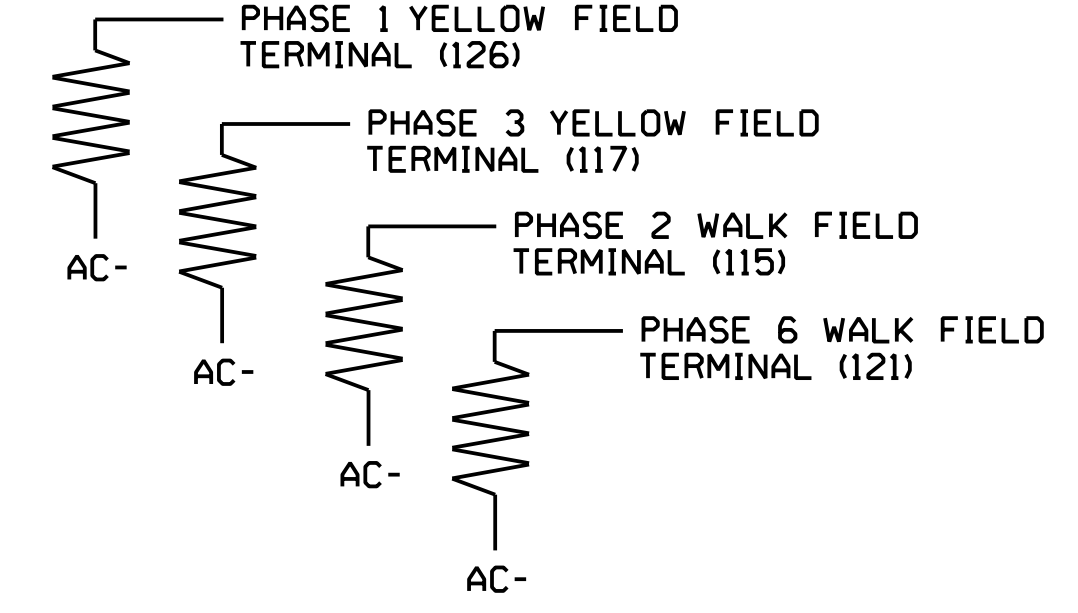

THIS ELECTRICAL DETAIL IS FOR THE SIGNAL DESIGN: 03-0331  
 DESIGNED: May 2022  
 SEALED: 5/17/2024  
 REVISED:

This plan supersedes the plan signed and sealed on 5/17/2024.



HNTB NORTH CAROLINA, P.C.  
 343 E. Six Forks Road, Suite 200  
 Raleigh, North Carolina 27609  
 NC License No: C-1554  
 (919) 546-8997

Signal Upgrade - Final Design  
 Electrical Detail - Sheet 1 of 7

**DOCUMENT NOT CONSIDERED FINAL UNLESS ALL SIGNATURES COMPLETED**

ELECTRICAL AND PROGRAMMING DETAILS FOR: I-40 EB Ramp / US 117 - NC 132 (N. College Road) at SR 2048 (Gordon Rd)

Division 3 New Hanover County Wilmington

PLAN DATE: August 2023 REVIEWED BY: N.K. Vianich  
 PREPARED BY: E.E. Tiller REVIEWED BY: N.R. Simmons

REVISIONS: INIT. DATE

DocuSigned by: *Notasha R. Simmons* 11/8/2024

SIGNATURE: \_\_\_\_\_ DATE: \_\_\_\_\_  
 SIG. INVENTORY NO. 03-0331



### 18 CHANNEL CONFLICT MONITOR PROGRAMMING DETAIL

(remove jumpers and set switches as shown)

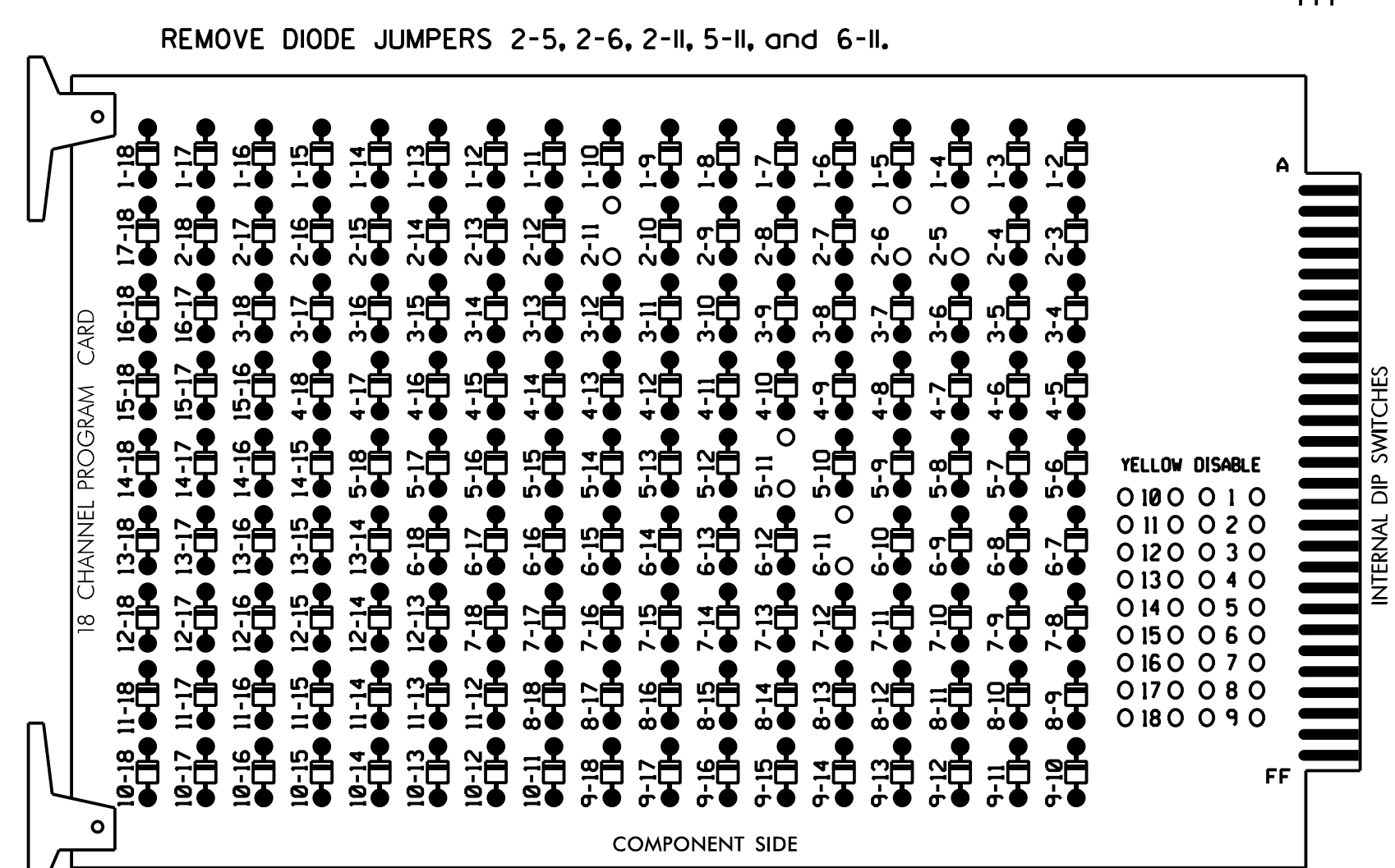

- REMOVE DIODE JUMPERS 2-5, 2-6, 2-11, 5-11, and 6-11.
- REMOVE JUMPERS AS SHOWN
- NOTES:
- Card is provided with all diode jumpers in place. Removal of any jumper allows its channels to run concurrently.
  - Ensure jumpers SEL2-SEL5 are present on the monitor board.
  - Ensure th Red Enable is active all times during normal operation.
  - Connect serial cable from conflict monitor to comm. port 1 of 2070 controller. Ensure conflict monitor communicates with 2070.

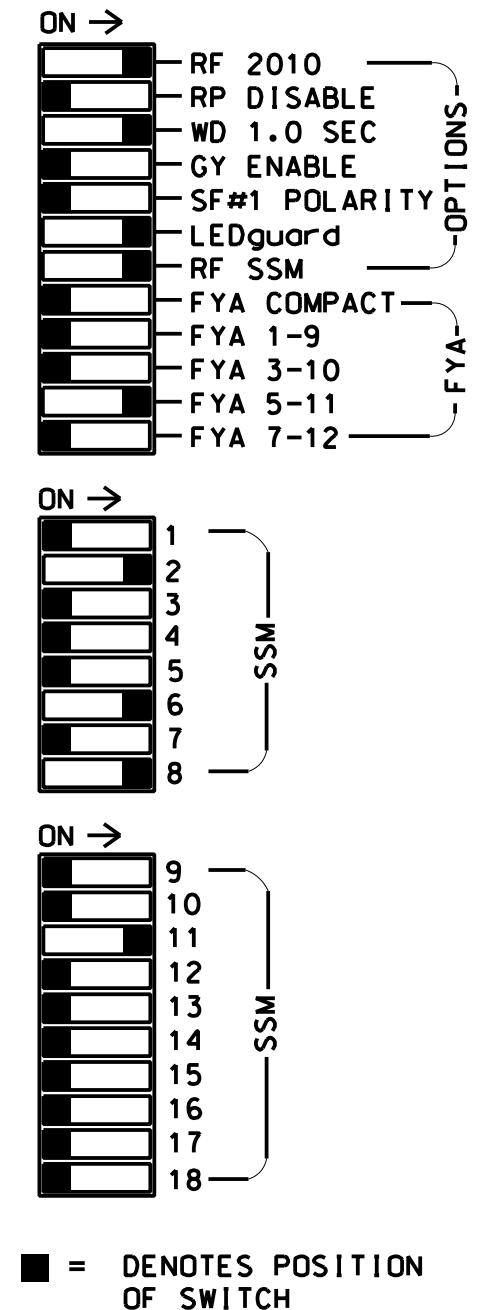
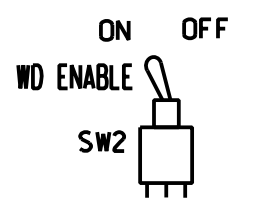

### NOTES

- To prevent "flash-conflict" problems, insert red flash program blocks for all unused vehicle load switches in the output file. The installer shall verify that signal heads flash in accordance with the Signal Plans.
- Enable Simultaneous Gap-Out for all Phases.
- Program phases 2 and 6 for Startup in Green.
- Program phases 2 and 6 for Yellow Flash.
- The cabinet and controller are part of the Wilmington Signal System.

### EQUIPMENT INFORMATION

CONTROLLER.....2070  
 CABINET.....332 W/ AUX  
 SOFTWARE.....ECONOLITE OASIS  
 CABINET MOUNT.....BASE  
 OUTPUT FILE POSITIONS...18 WITH AUX. OUTPUT FILE  
 LOAD SWITCHES USED.....S2,S7,S8,S11,AUX S4  
 PHASES USED.....2,5,6,8  
 OVERLAP "A".....NOT USED  
 OVERLAP "B".....NOT USED  
 OVERLAP "C".....5+6  
 OVERLAP "D".....NOT USED

### SIGNAL HEAD HOOK-UP CHART

LOAD SWITCH NO.	S1	S2	S3	S4	S5	S6	S7	S8	S9	S10	S11	S12	AUX S1	AUX S2	AUX S3	AUX S4	AUX S5	AUX S6	
CMU CHANNEL NO.	1	2	13	3	4	14	5	6	15	7	8	16	9	10	17	11	12	18	
PHASE	1	2	2 PED	3	4	4 PED	5	6	6 PED	7	8	8 PED	OLA	OLB	SPARE	OLC	OLD	SPARE	
SIGNAL HEAD NO.	NU	21	22	NU	NU	NU	NU	51	61	62	NU	NU	81,82	83,84	NU	NU	NU	51	NU
RED	128	128							134	134			107	107					
YELLOW	129	129						*	135	135			108						
GREEN	130									136			109						
RED ARROW																			A114
YELLOW ARROW													108						A115
FLASHING YELLOW ARROW																			A116
GREEN ARROW			130					133	136				109						
Hand icon																			
Person icon																			

NU = Not Used  
 \* Denotes install load resistor. See load resistor installation detail this sheet.  
 ★ See pictorial of head wiring in detail this sheet.

### INPUT FILE POSITION LAYOUT

(front view)

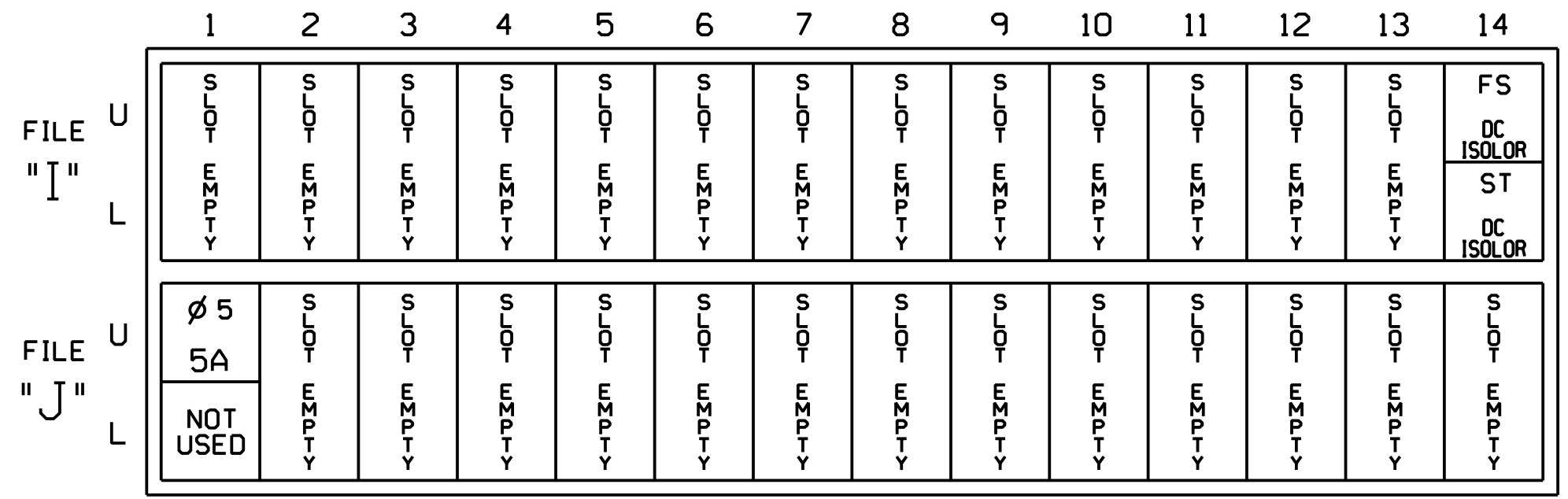

EX.: 1A, 2A, ETC. = LOOP NO.'S

FS = FLASH SENSE  
 ST = STOP TIME

### INPUT FILE CONNECTION & PROGRAMMING CHART

LOOP NO.	LOOP TERMINAL	INPUT FILE POS.	PIN NO.	INPUT ASSIGNMENT NO.	DETECTOR NO.	NEMA PHASE	CALL	EXTEND	FULL TIME DELAY	STRETCH TIME	DELAY TIME
5A	TB3-1,2	J1U	55	17	5	5	Y	Y			15
	-	14U	47	9 ★	22	2	Y	Y			3
	-	J1U	55	17 ★	55	5	Y	Y			3

\* See Input Page Assignment programming details on sheet 3.

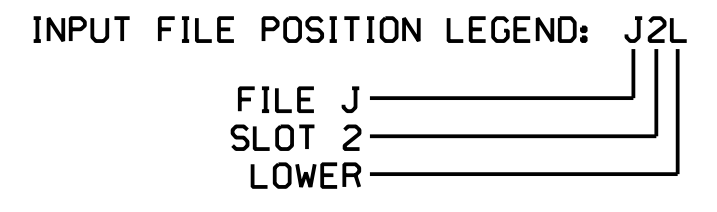

### FYA SIGNAL WIRING DETAIL

(wire signal head as shown)

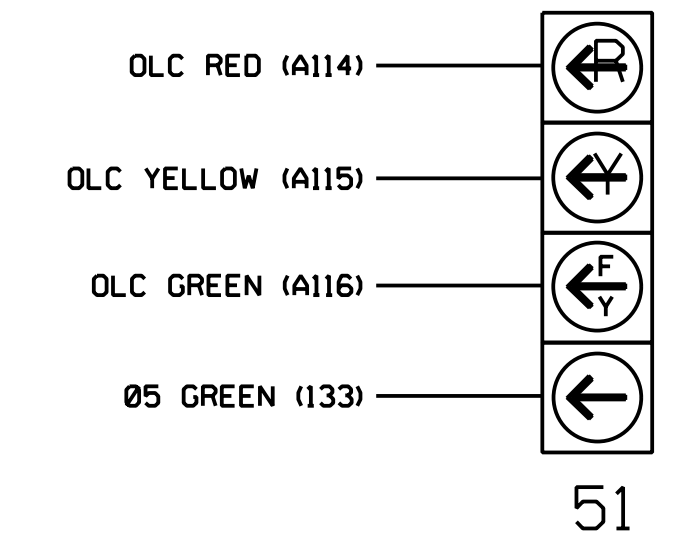

NOTE  
 The sequence display for signal head 51 requires special logic programming. See sheet 2 for programming instructions.

### SPECIAL DETECTOR NOTE

Install a multizone microwave detection system for vehicle detection. Perform installation according to manufacturer's directions and NCDOT engineer-approved mounting locations to accomplish detection schemes shown on the Signal Design Plans.

### LOAD RESISTOR INSTALLATION DETAIL

(install resistor as shown below)

ACCEPTABLE VALUES

VALUE (ohms)	WTAGE
1.5K - 1.9K	25W (min)
2.0K - 3.0K	10W (min)

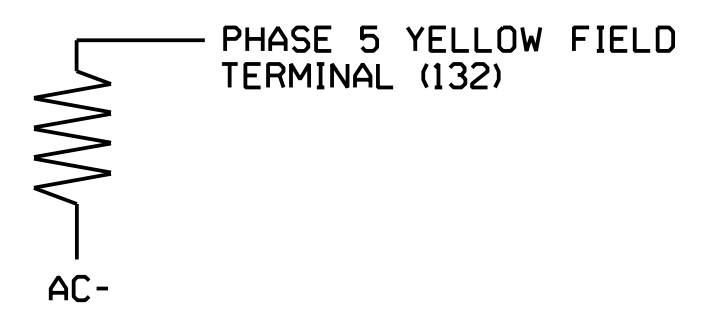

THIS ELECTRICAL DETAIL IS FOR THE SIGNAL DESIGN: 03-0258T1  
 DESIGNED: May 2022  
 SEALED: 5/17/2024  
 REVISED:

This plan supersedes the plan signed and sealed on 5/17/2024.

**HNTB**  
 HNTB NORTH CAROLINA, P.C.  
 343 E. Six Forks Road, Suite 200  
 Raleigh, North Carolina 27609  
 NC License No: C-1554  
 (919) 546-8997

Signal Upgrade-  
 Electrical Detail - Sheet 1 of 4  
 (Construction Phase 1)

DOCUMENT NOT CONSIDERED FINAL UNLESS ALL SIGNATURES COMPLETED

ELECTRICAL AND PROGRAMMING DETAILS FOR:  
 SR 2048 (Gordon Rd) at I-40 WB Ramps

Division 3 New Hanover County Wilmington

PLAN DATE: August 2023 REVIEWED BY: N.K. Vianich  
 PREPARED BY: E.E. Tiller REVIEWED BY: N.R. Simmons

REVISIONS: INIT. DATE

Seal: NORTH CAROLINA PROFESSIONAL ENGINEER SEAL 031464  
 Signature: Natasha R. Simmons 11/8/2024  
 Date: 11/8/2024  
 Sig. Inventory No. 03-0258T1



### 18 CHANNEL CONFLICT MONITOR PROGRAMMING DETAIL

(remove jumpers and set switches as shown)

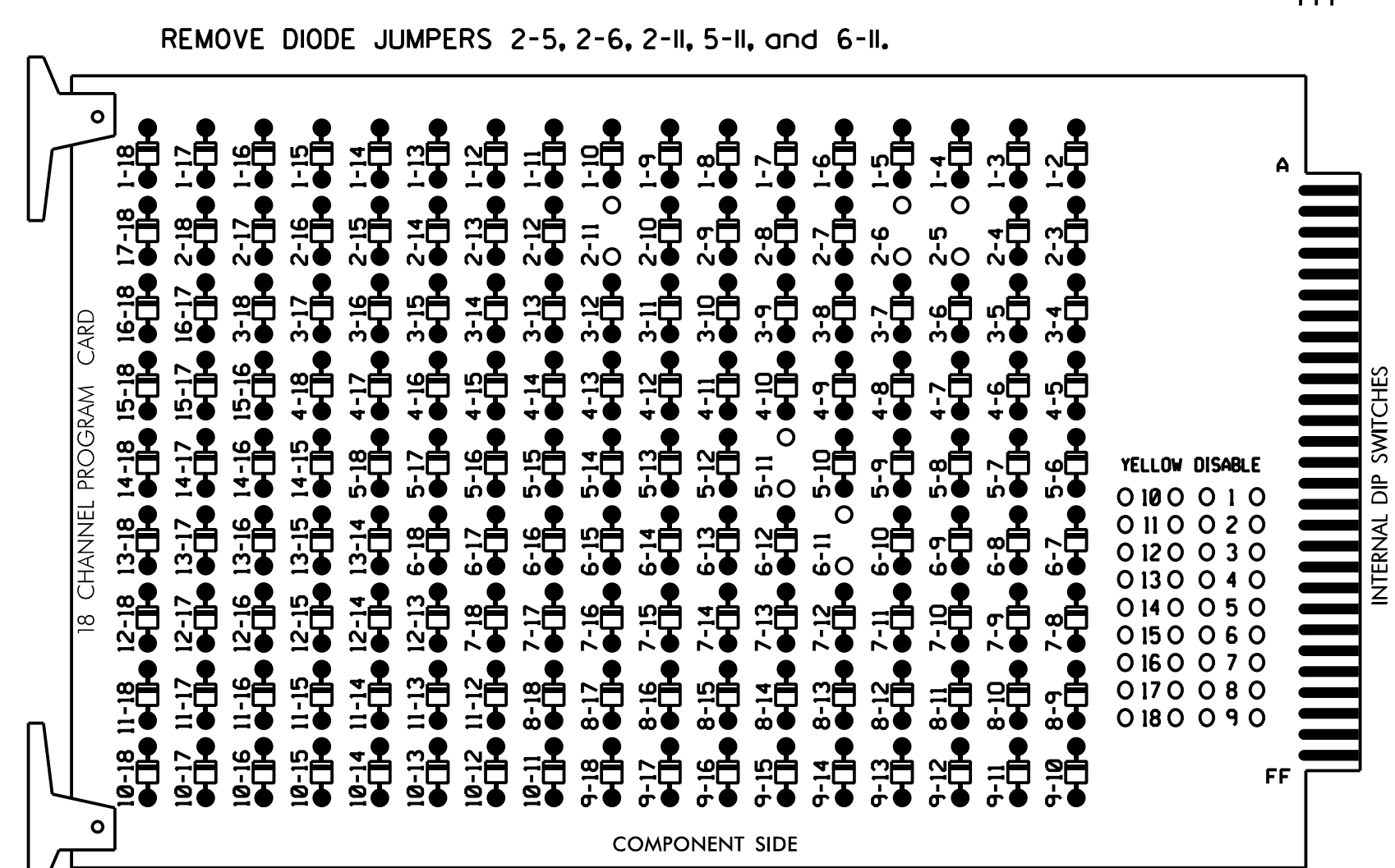

REMOVE JUMPERS AS SHOWN

NOTES:

1. Card is provided with all diode jumpers in place. Removal of any jumper allows its channels to run concurrently.
2. Ensure jumpers SEL2-SEL5 are present on the monitor board.
3. Ensure th Red Enable is active all times during normal operation.
4. Connect serial cable from conflict monitor to comm. port 1 of 2070 controller. Ensure conflict monitor communicates with 2070.

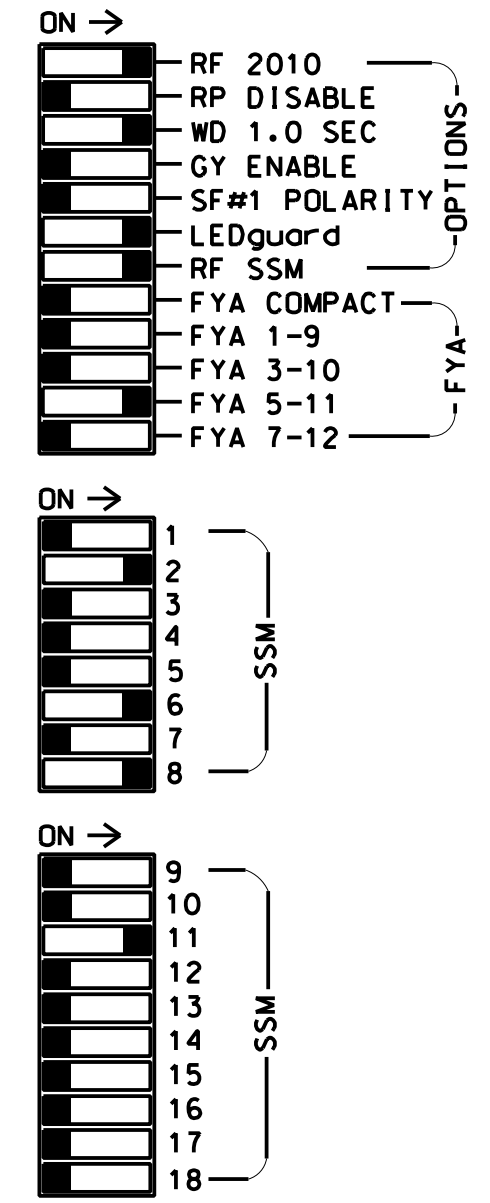
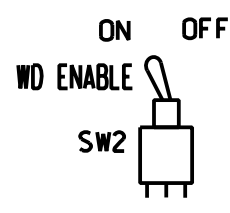

■ = DENOTES POSITION OF SWITCH

### NOTES

1. To prevent "flash-conflict" problems, insert red flash program blocks for all unused vehicle load switches in the output file. The installer shall verify that signal heads flash in accordance with the Signal Plans.
2. Enable Simultaneous Gap-Out for all Phases.
3. Program phases 2 and 6 for Variable Initial and Gap Reduction.
4. Program phases 2 and 6 for Startup in Green.
5. Program phases 2 and 6 for Yellow Flash.
6. The cabinet and controller are part of the Wilmington Signal System.

### EQUIPMENT INFORMATION

CONTROLLER.....2070  
 CABINET.....332 W/ AUX  
 SOFTWARE.....ECONOLITE OASIS  
 CABINET MOUNT.....BASE  
 OUTPUT FILE POSITIONS...18 WITH AUX. OUTPUT FILE  
 LOAD SWITCHES USED.....S2,S7,S8,S11,AUX S4  
 PHASES USED.....2,5,6,8  
 OVERLAP "A".....NOT USED  
 OVERLAP "B".....NOT USED  
 OVERLAP "C".....5+6  
 OVERLAP "D".....NOT USED

### SIGNAL HEAD HOOK-UP CHART

LOAD SWITCH NO.	S1	S2	S3	S4	S5	S6	S7	S8	S9	S10	S11	S12	AUX S1	AUX S2	AUX S3	AUX S4	AUX S5	AUX S6		
CMU CHANNEL NO.	1	2	13	3	4	14	5	6	15	7	8	16	9	10	17	11	12	18		
PHASE	1	2	2 PED	3	4	4 PED	5	6	6 PED	7	8	8 PED	OLA	OLB	SPARE	OLC	OLD	SPARE		
SIGNAL HEAD NO.	NU	21	22	NU	NU	NU	NU	51	61	62	NU	NU	81,82	83,84	NU	NU	NU	51	NU	
RED	128	128							134	134				107						
YELLOW	129	129						*	135	135										
GREEN	130									136										
RED ARROW													107						A114	
YELLOW ARROW														108	108					A115
FLASHING YELLOW ARROW																				A116
GREEN ARROW									130					133	136					
Hand icon																				
Person icon																				

NU = Not Used  
 \* Denotes install load resistor. See load resistor installation detail this sheet.  
 ★ See pictorial of head wiring in detail this sheet.

### INPUT FILE POSITION LAYOUT

(front view)

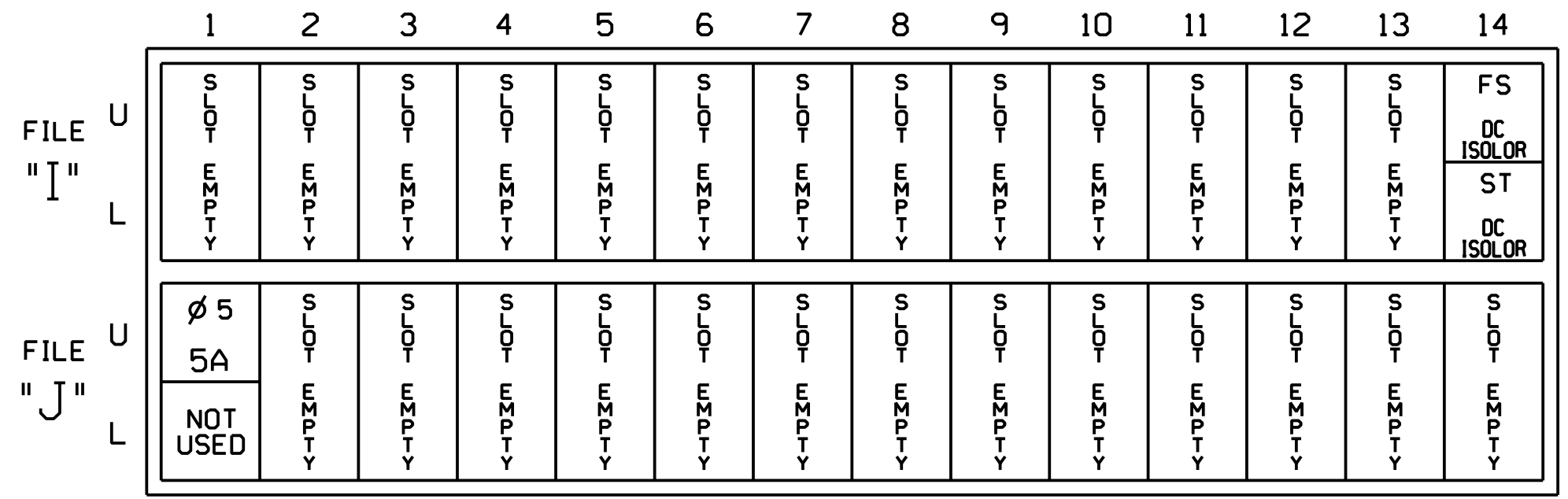

EX.: 1A, 2A, ETC. = LOOP NO.'S

FS = FLASH SENSE  
ST = STOP TIME

### INPUT FILE CONNECTION & PROGRAMMING CHART

LOOP NO.	LOOP TERMINAL	INPUT FILE POS.	PIN NO.	INPUT ASSIGNMENT NO.	DETECTOR NO.	NEMA PHASE	CALL	EXTEND	FULL TIME DELAY	STRETCH TIME	DELAY TIME
5A <sup>1</sup>	TB3-1,2	J1U	55	17	5	5	Y	Y			15
	-	14U	47	9 ★	22	2	Y	Y			3
	-	J1U	55	17 ★	55	5	Y	Y			3

\* See Input Page Assignment programming details on sheet 3.

#### INPUT FILE POSITION LEGEND: J2L

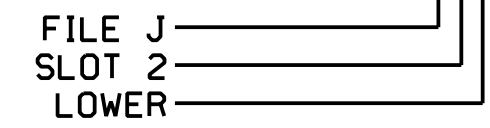

### FYA SIGNAL WIRING DETAIL

(wire signal head as shown)

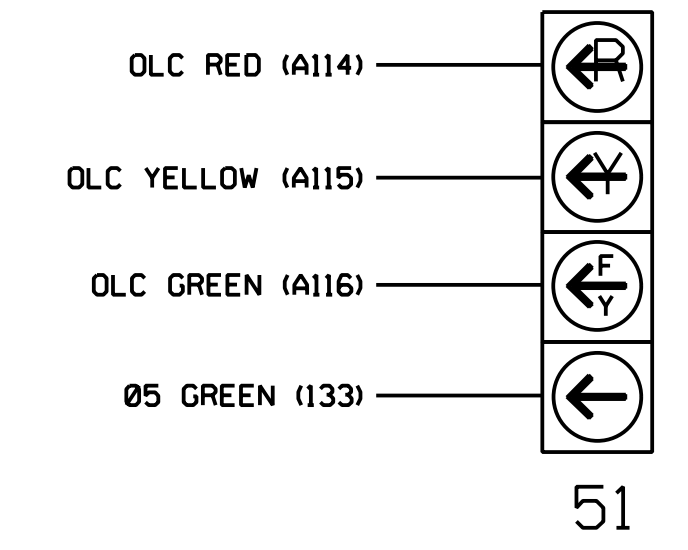

#### NOTE

The sequence display for signal head 51 requires special logic programming. See sheet 2 for programming instructions.

### LOAD RESISTOR INSTALLATION DETAIL

(install resistor as shown below)

VALUE (ohms)	WTAGE
1.5K - 1.9K	25W (min)
2.0K - 3.0K	10W (min)

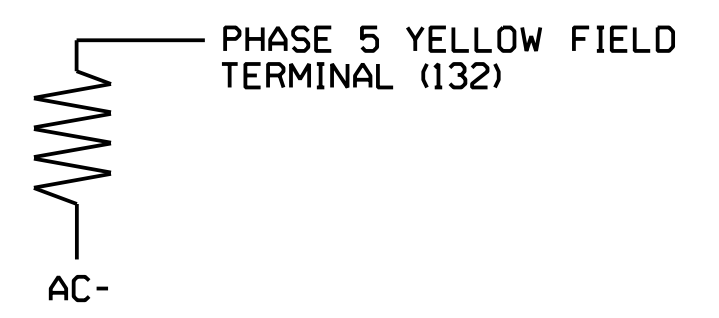

This plan supersedes the plan signed and sealed on 5/17/2024.

THIS ELECTRICAL DETAIL IS FOR THE SIGNAL DESIGN: 03-0258T2  
 DESIGNED: May 2022  
 SEALED: 5/17/2024  
 REVISED:

**HNTB**  
 HNTB NORTH CAROLINA, P.C.  
 343 E. Six Forks Road, Suite 200  
 Raleigh, North Carolina 27609  
 NC License No: C-1554  
 (919) 546-8997

Signal Upgrade-  
 Electrical Detail - Sheet 1 of 4  
 (Construction Phase 2)

DOCUMENT NOT CONSIDERED FINAL UNLESS ALL SIGNATURES COMPLETED

Division 3 New Hanover County Wilmington

SR 2048 (Gordon Rd) at I-40 WB Ramps

PLAN DATE: August 2023 REVIEWED BY: N.K. Vianich  
 PREPARED BY: E.E. Tiller REVIEWED BY: N.R. Simmons

REVISIONS: INIT. DATE

Seal: NORTH CAROLINA PROFESSIONAL ENGINEER SEAL 031464  
 Signature: NATASHA R. SIMMONS  
 Date: 11/8/2024  
 Sig. Inventory No. 03-0258T2



### 18 CHANNEL CONFLICT MONITOR PROGRAMMING DETAIL

(remove jumpers and set switches as shown)

REMOVE DIODE JUMPERS 2-5, 2-6, 2-11, 2-13, 2-15, 5-11, 5-13, 6-11, 6-13, 6-15, 8-16, 11-13, 11-15, and 13-15.

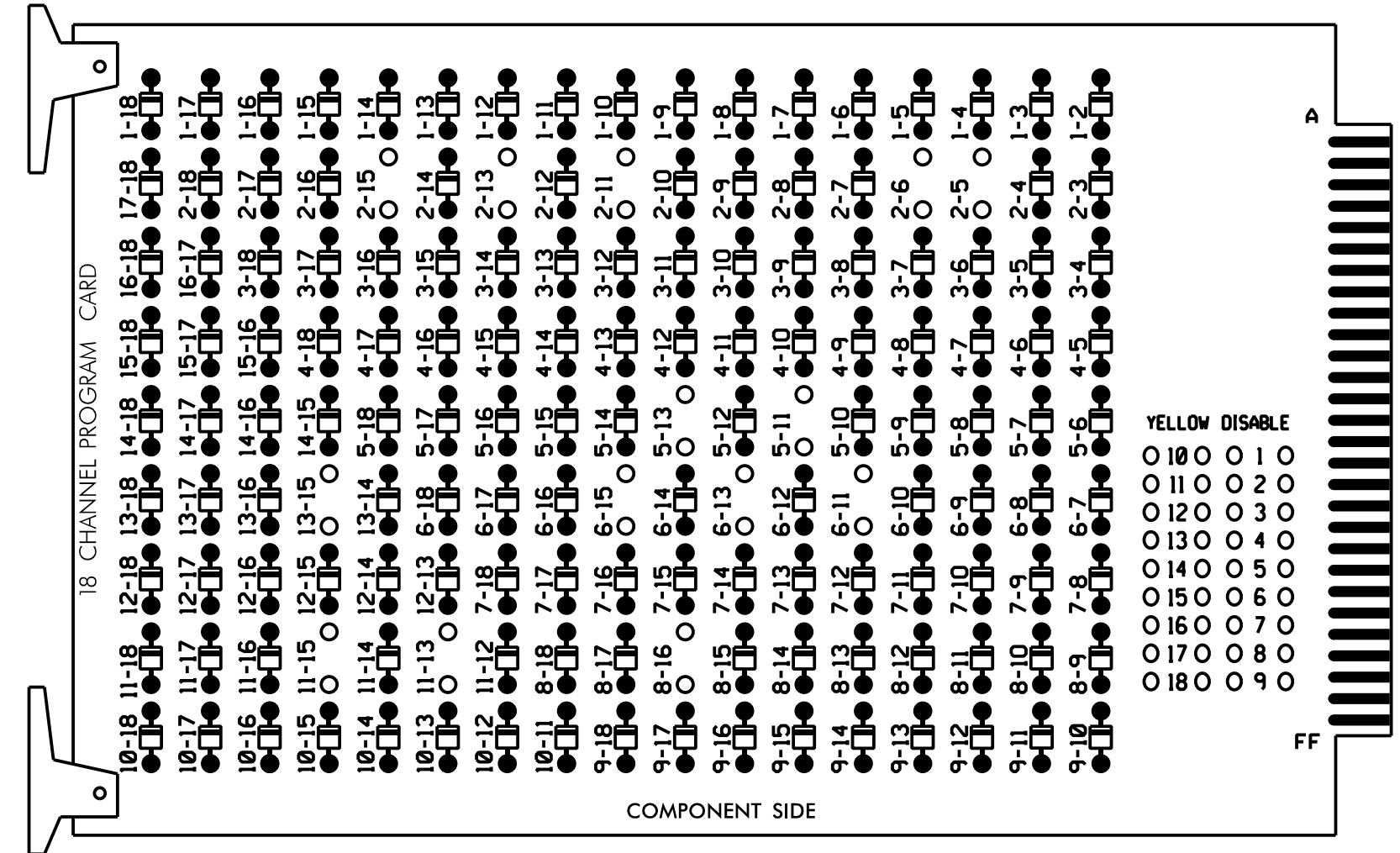

REMOVE JUMPERS AS SHOWN

NOTES:

- 1. Card is provided with all diode jumpers in place. Removal of any jumper allows its channels to run concurrently.
2. Ensure jumpers SEL2-SEL5 are present on the monitor board.
3. Ensure th Red Enable is active all times during normal operation.
4. Connect serial cable from conflict monitor to comm. port 1 of 2070 controller. Ensure conflict monitor communicates with 2070.

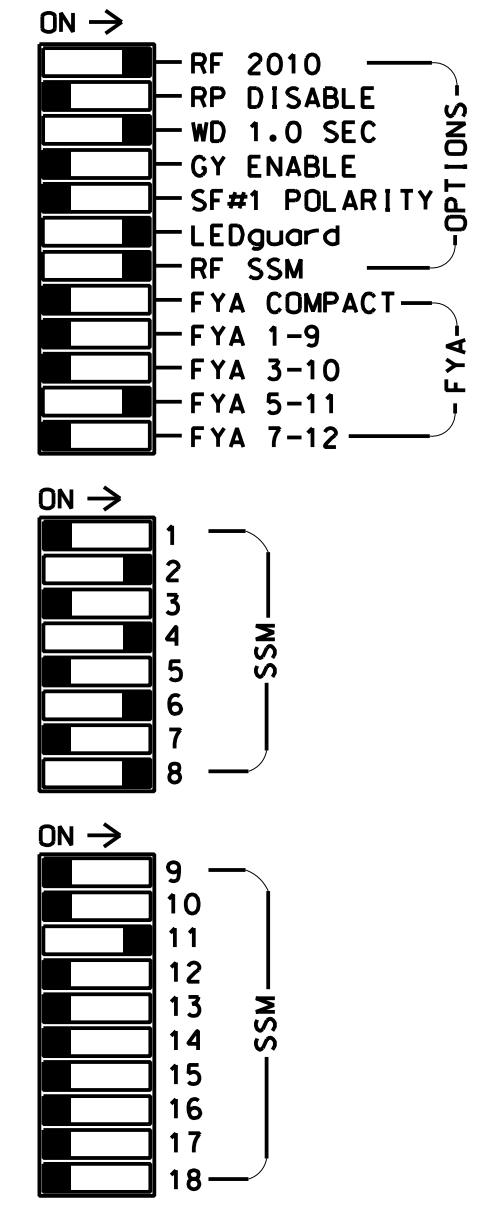
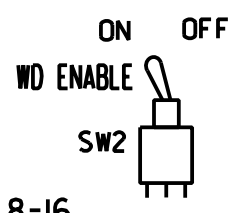

■ = DENOTES POSITION OF SWITCH

### NOTES

- 1. To prevent "flash-conflict" problems, insert red flash program blocks for all unused vehicle load switches in the output file. The installer shall verify that signal heads flash in accordance with the Signal Plans.
2. Enable Simultaneous Gap-Out for all Phases.
3. Program phases 2 and 6 for Startup in Green.
4. Program phases 2 and 6 for Yellow Flash.
5. The cabinet and controller are part of the Wilmington Signal System.

### EQUIPMENT INFORMATION

CONTROLLER.....2070
CABINET.....332 W/ AUX
SOFTWARE.....ECONOLITE OASIS
CABINET MOUNT.....BASE
OUTPUT FILE POSITIONS...18 WITH AUX. OUTPUT FILE
LOAD SWITCHES USED.....S2,S3,S7,S8,S9,S11,S12,AUX S4
PHASES USED.....2,2 PED,4,5,6,6 PED,8,8 PED
OVERLAP "A".....NOT USED
OVERLAP "B".....NOT USED
OVERLAP "C".....5+6
OVERLAP "D".....NOT USED

### SIGNAL HEAD HOOK-UP CHART

Table with columns for Load Switch No., CMU Channel No., Phase, Signal Head No., and various signal types (RED, YELLOW, GREEN, ARROW, FLASHING YELLOW ARROW) across 18 channels.

NU = Not Used
\* Denotes install load resistor. See load resistor installation detail this sheet.
★ See pictorial of head wiring in detail this sheet.

### INPUT FILE POSITION LAYOUT

(front view)

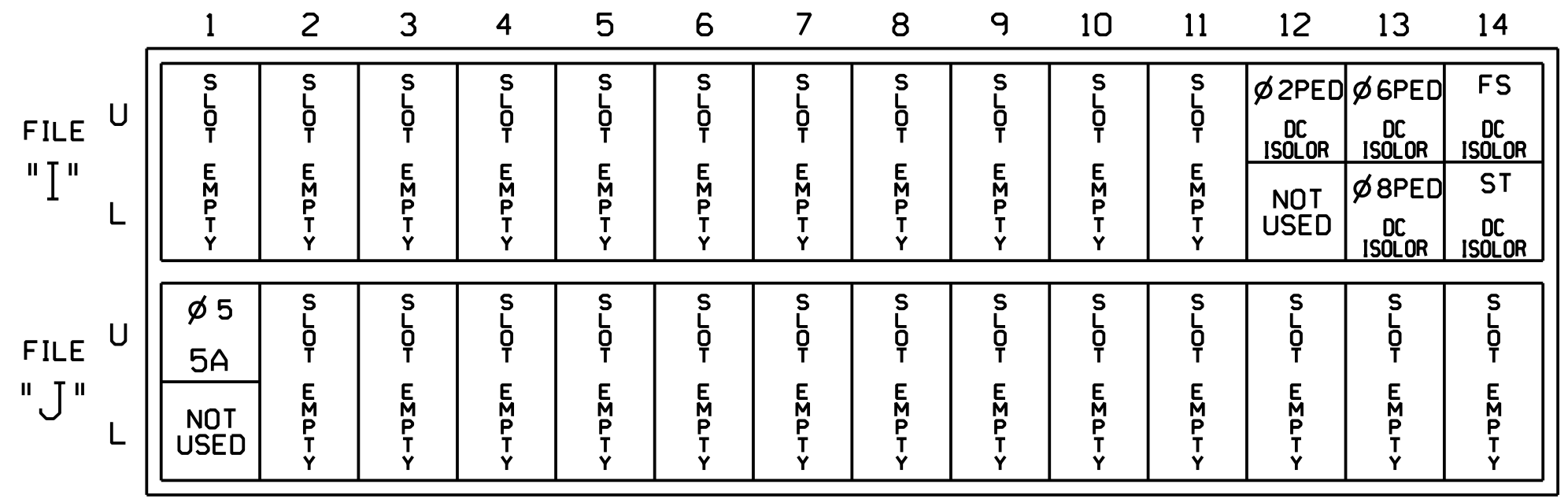

EX.: 1A, 2A, ETC. = LOOP NO.'S

FS = FLASH SENSE
ST = STOP TIME

### INPUT FILE CONNECTION & PROGRAMMING CHART

Table with columns: LOOP NO., LOOP TERMINAL, INPUT FILE POS., PIN NO., INPUT ASSIGNMENT NO., DETECTOR NO., NEMA PHASE, CALL, EXTEND, FULL TIME DELAY, STRETCH TIME, DELAY TIME.

NOTE:
INSTALL DC ISOLATORS IN INPUT FILE SLOTS 112 AND 113.

\* See Input Page Assignment programming details on sheet 3.

INPUT FILE POSITION LEGEND: J2L

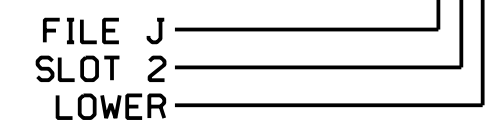

### FYA SIGNAL WIRING DETAIL

(wire signal head as shown)

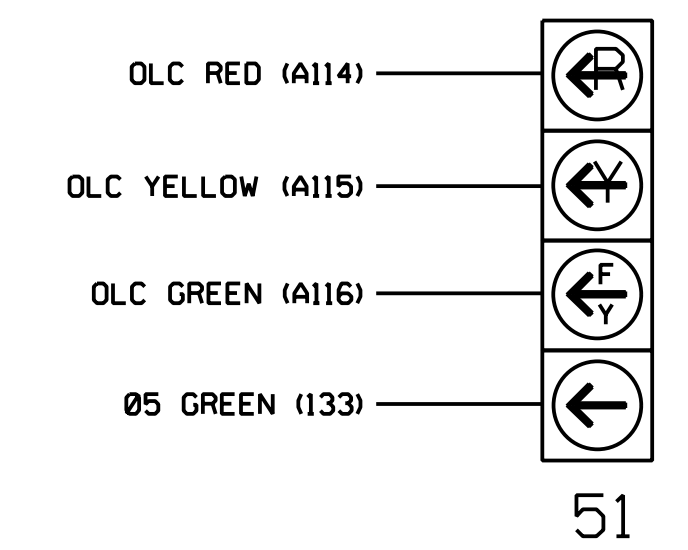

### SPECIAL DETECTOR NOTE

Install a multizone microwave detection system for vehicle detection. Perform installation according to manufacturer's directions and NCDOT engineer-approved mounting locations to accomplish detection schemes shown on the Signal Design Plans.

### COUNTDOWN PEDESTRIAN SIGNAL OPERATION

Countdown Ped Signals are required to display timing only during Ped Clearance Interval. Consult Ped Signal Module user's manual for instructions on selecting this feature.

### NOTE

The sequence display for signal head 51 requires special logic programming. See sheet 2 for programming instructions.

### LOAD RESISTOR INSTALLATION DETAIL

(install resistor as shown below)

Table with columns: VALUE (ohms), WTAGE. Values: 1.5K - 1.9K, 25W (min); 2.0K - 3.0K, 10W (min).

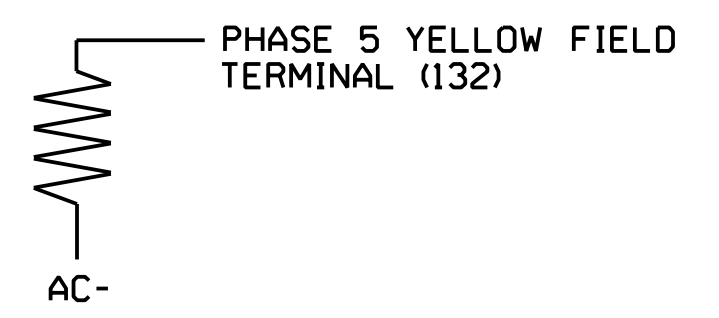

THIS ELECTRICAL DETAIL IS FOR THE SIGNAL DESIGN: 03-0258
DESIGNED: May 2022
SEALED: 5/17/2024
REVISED:

This plan supersedes the plan signed and sealed on 5/17/2024.



HNTB NORTH CAROLINA, P.C.
343 E. Six Forks Road, Suite 200
Raleigh, North Carolina 27609
NC License No: C-1554
(919) 546-8997

Signal Upgrade - Final Design
Electrical Detail - Sheet 1 of 4

DOCUMENT NOT CONSIDERED FINAL UNLESS ALL SIGNATURES COMPLETED

Professional seal and signature block for Natasha R. Simmons, North Carolina Professional Engineer, dated 11/8/2024.



### 18 CHANNEL CONFLICT MONITOR PROGRAMMING DETAIL

(remove jumpers and set switches as shown)

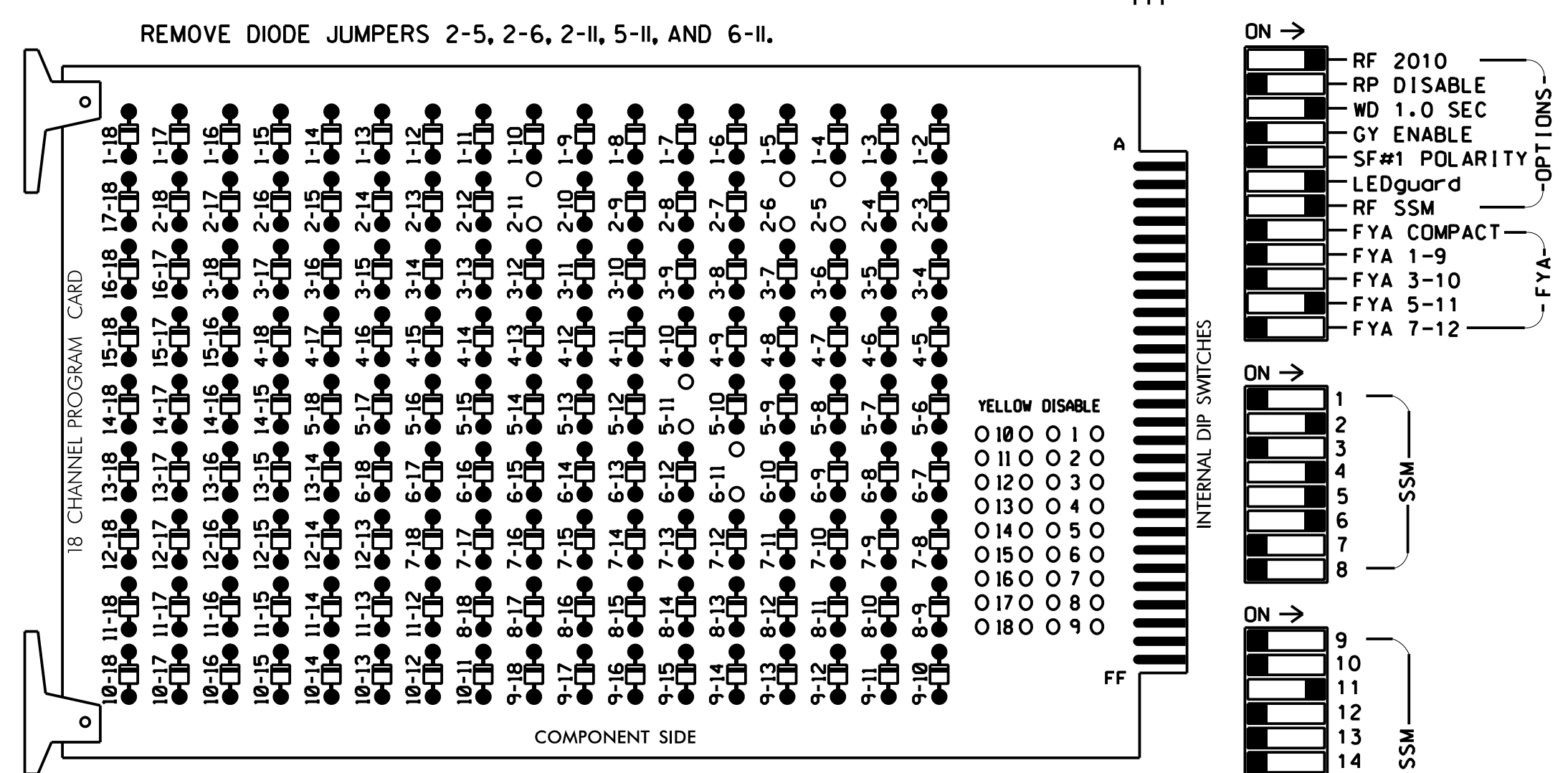

#### NOTES:

1. Card is provided with all diode jumpers in place. Removal of any jumper allows its channels to run concurrently.
2. Ensure jumpers SEL2-SEL5 are present on the monitor board.
3. Ensure th Red Enable is active all times during normal operation.
4. Connect serial cable from conflict monitor to comm. port 1 of 2070 controller. Ensure conflict monitor communicates with 2070.

### NOTES

1. To prevent "flash-conflict" problems, insert red flash program blocks for all unused vehicle load switches in the output file. The installer shall verify that signal heads flash in accordance with the Signal Plans.
2. Enable Simultaneous Gap-Out for all Phases.
3. Program phases 2 and 6 for Startup in Green.
4. Program phases 2 and 6 for Yellow Flash.
6. The cabinet and controller are part of the Wilmington Signal System.

### EQUIPMENT INFORMATION

CONTROLLER.....2070  
 CABINET.....332 W/ AUX  
 SOFTWARE.....ECONOLITE OASIS  
 CABINET MOUNT.....BASE  
 OUTPUT FILE POSITIONS...18 WITH AUX. OUTPUT FILE  
 LOAD SWITCHES USED.....S2,S5,S7,S8,AUX S4  
 PHASES USED.....2,4,5,6  
 OVERLAP "A".....NOT USED  
 OVERLAP "B".....NOT USED  
 OVERLAP "C".....5+6  
 OVERLAP "D".....NOT USED

### SIGNAL HEAD HOOK-UP CHART

LOAD SWITCH NO.	S1	S2	S3	S4	S5	S6	S7	S8	S9	S10	S11	S12	AUX S1	AUX S2	AUX S3	AUX S4	AUX S5	AUX S6	
CMU CHANNEL NO.	1	2	13	3	4	14	5	6	15	7	8	16	9	10	17	11	12	18	
PHASE	1	2	2 PED	3	4	4 PED	5	6	6 PED	7	8	8 PED	OLA	OLB	SPARE	OLC	OLD	SPARE	
SIGNAL HEAD NO.	NU	21,22	NU	NU	41, 42, 43	62	NU	42	51	61,62	NU	NU	NU	NU	NU	51	NU	NU	
RED		128			101			*		134									
YELLOW		129			102					135									
GREEN		130			103					136									
RED ARROW																		A114	
YELLOW ARROW						102	132												A115
FLASHING YELLOW ARROW																			A116
GREEN ARROW						103	133	133											
Hand icon																			
Person icon																			

NU = Not Used  
 \* Denotes install load resistor. See load resistor installation detail this sheet.  
 ★ See pictorial of head wiring in detail this sheet.

### INPUT FILE POSITION LAYOUT

(front view)

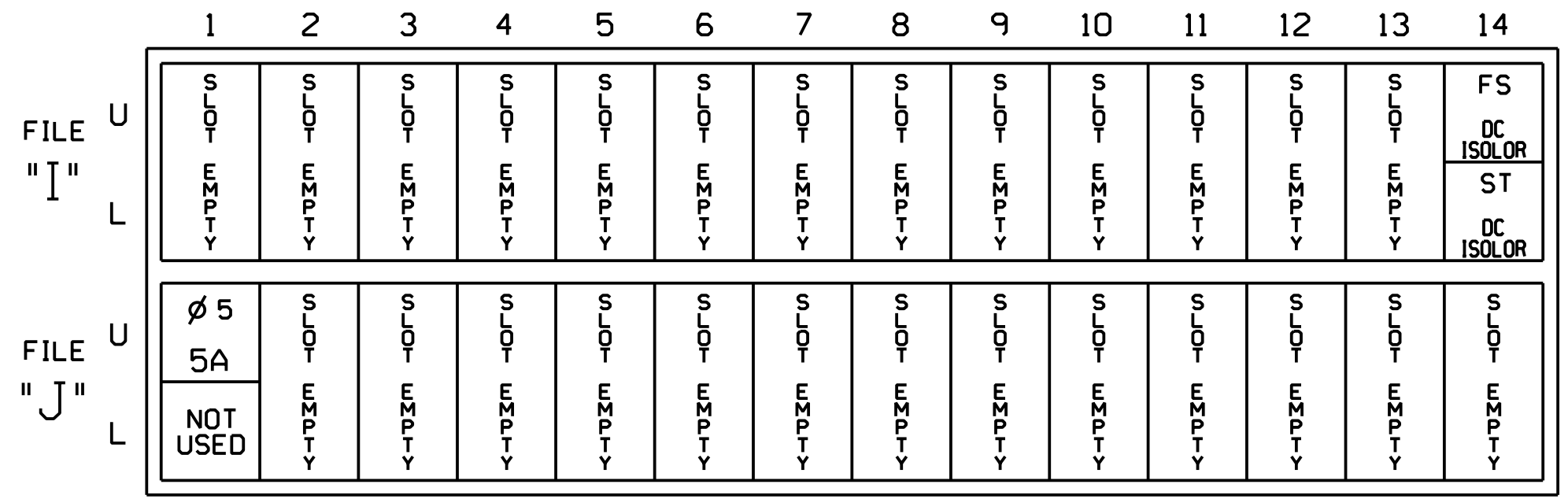

EX.: 1A, 2A, ETC. = LOOP NO.'S  
 FS = FLASH SENSE  
 ST = STOP TIME

### INPUT FILE CONNECTION & PROGRAMMING CHART

LOOP NO.	LOOP TERMINAL	INPUT FILE POS.	PIN NO.	INPUT ASSIGNMENT NO.	DETECTOR NO.	NEMA PHASE	CALL	EXTEND	FULL TIME DELAY	STRETCH TIME	DELAY TIME
5A	TB3-1,2	J1U	55	17	5	5	Y	Y			15
	-	14U	47	9 ★	22	2	Y	Y			
	-	J1U	55	17 ★	55	5	Y	Y			

\* See Input Page Assignment programming details on sheet 3.

#### INPUT FILE POSITION LEGEND: J2L

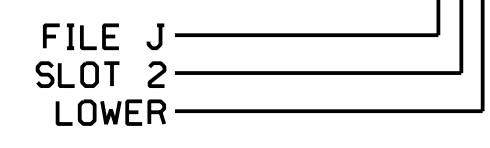

### FYA SIGNAL WIRING DETAIL

(wire signal head as shown)

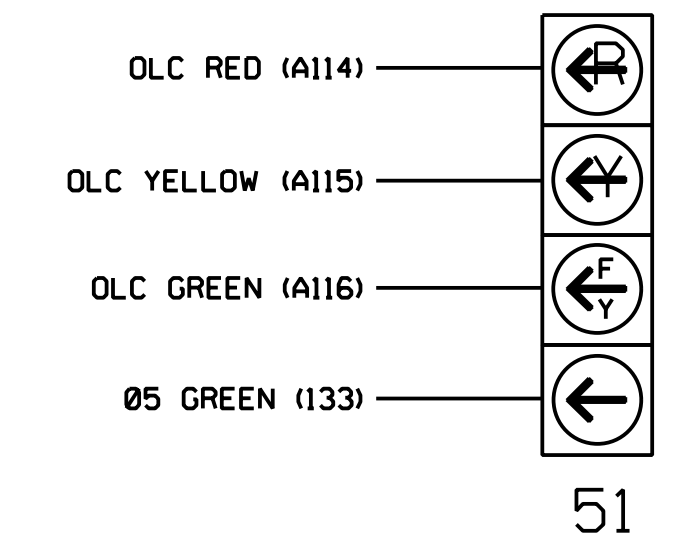

#### NOTE

The sequence display for signal head 51 requires special logic programming. See sheet 2 for programming instructions.

### LOAD RESISTOR INSTALLATION DETAIL

(install resistor as shown below)

ACCEPTABLE VALUES	
VALUE (ohms)	WTAGE
1.5K - 1.9K	25W (min)
2.0K - 3.0K	10W (min)

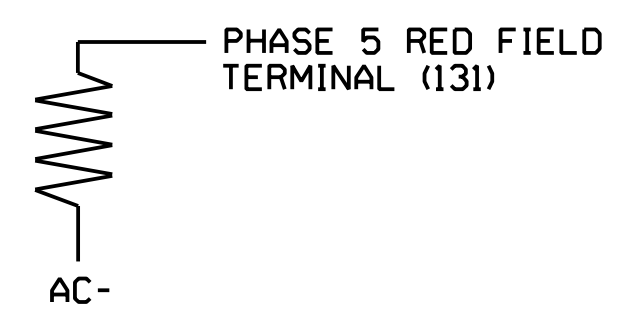

This plan supersedes the plan signed and sealed on 5/17/2024.

THIS ELECTRICAL DETAIL IS FOR THE SIGNAL DESIGN: 03-0840T1  
 DESIGNED: May 2022  
 SEALED: 5/17/2024  
 REVISED:



HNTB NORTH CAROLINA, P.C.  
 343 E. Six Forks Road, Suite 200  
 Raleigh, North Carolina 27609  
 NC License No: C-1554  
 (919) 546-8997

Signal Upgrade-  
 Electrical Detail - Sheet 1 of 4  
 (Construction Phase 1)

DOCUMENT NOT CONSIDERED FINAL UNLESS ALL SIGNATURES COMPLETED

ELECTRICAL AND PROGRAMMING DETAILS FOR: Prepared in the Office of: 	SR 2048 (Gordon Rd)	SEAL 
	at SR 2117 (Harris Rd)	
Division 3 New Hanover County Wilmington PLAN DATE: August 2023 REVIEWED BY: N.K. Vlanich PREPARED BY: E.E. Tiller REVIEWED BY: N.R. Simmons	REVISIONS INIT. DATE	11/8/2024 DATE 03-0840T1 SIG. INVENTORY NO.



### 18 CHANNEL CONFLICT MONITOR PROGRAMMING DETAIL

(remove jumpers and set switches as shown)

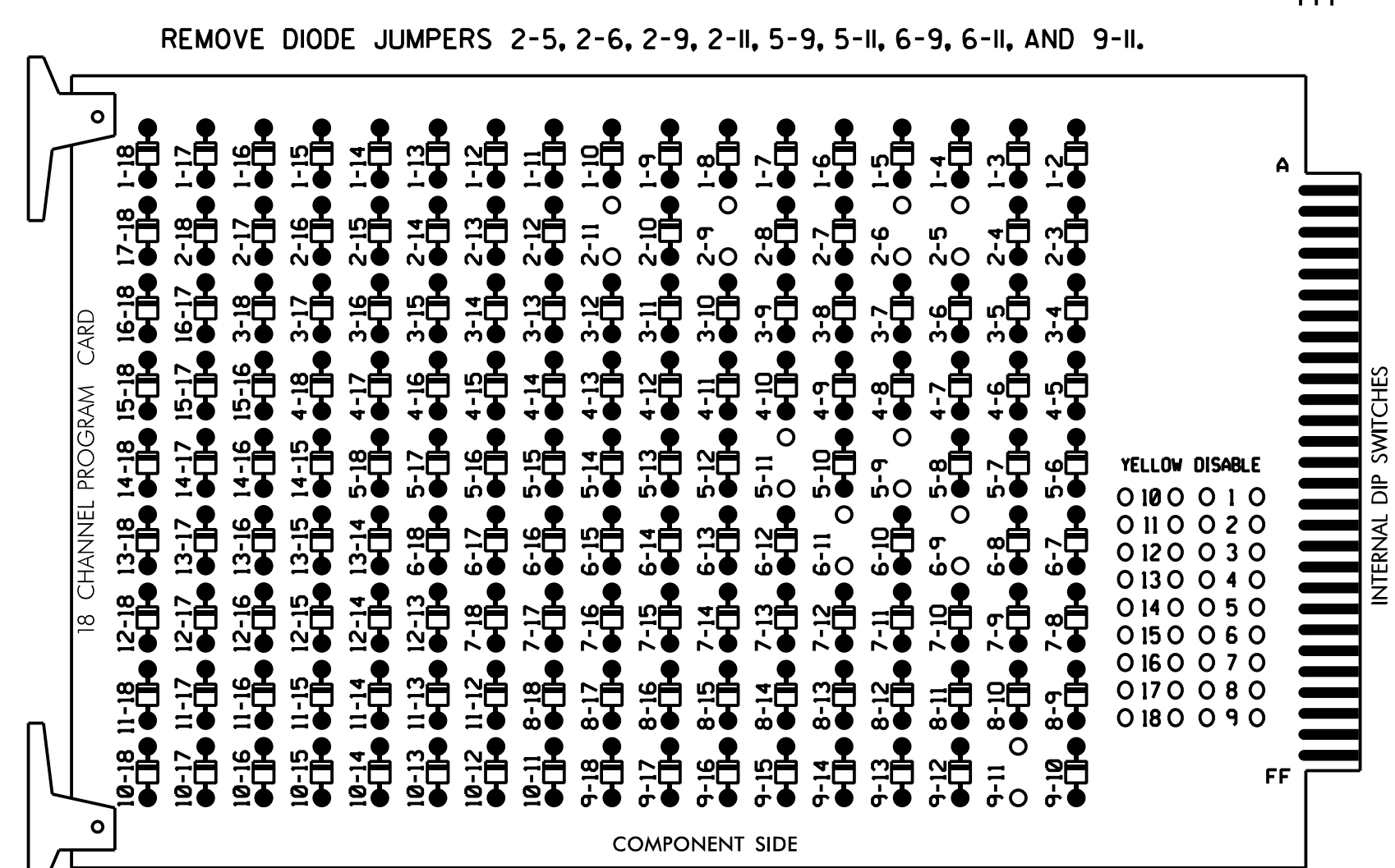

#### NOTES:

- Card is provided with all diode jumpers in place. Removal of any jumper allows its channels to run concurrently.
- Ensure jumpers SEL2-SEL5 are present on the monitor board.
- Ensure th Red Enable is active all times during normal operation.
- Connect serial cable from conflict monitor to comm. port 1 of 2070 controller. Ensure conflict monitor communicates with 2070.

### NOTES

- To prevent "flash-conflict" problems, insert red flash program blocks for all unused vehicle load switches in the output file. The installer shall verify that signal heads flash in accordance with the Signal Plans.
- Enable Simultaneous Gap-Out for all Phases.
- Program phases 2 and 6 for Startup in Green.
- Program phases 2 and 6 for Yellow Flash, and overlap 1 as Wag Overlap.
- The cabinet and controller are part of the Wilmington Signal System.

### EQUIPMENT INFORMATION

CONTROLLER.....2070  
 CABINET.....332 W/ AUX  
 SOFTWARE.....ECONOLITE OASIS  
 CABINET MOUNT.....BASE  
 OUTPUT FILE POSITIONS...18 WITH AUX. OUTPUT FILE  
 LOAD SWITCHES USED.....S2,S5,S7,S8,AUX S1,AUX S4  
 PHASES USED.....2,4,5,6  
 OVERLAP "A".....2  
 OVERLAP "B".....NOT USED  
 OVERLAP "C".....5+6  
 OVERLAP "D".....NOT USED

### SIGNAL HEAD HOOK-UP CHART

LOAD SWITCH NO.	S1	S2	S3	S4	S5	S6	S7	S8	S9	S10	S11	S12	AUX S1	AUX S2	AUX S3	AUX S4	AUX S5	AUX S6
CMU CHANNEL NO.	1	2	13	3	4	14	5	6	15	7	8	16	9	10	17	11	12	18
PHASE	1	2	2 PED	3	4	4 PED	5	6	6 PED	7	8	8 PED	OLA	OLB	SPARE	OLC	OLD	SPARE
SIGNAL HEAD NO.	NU	21,22	NU	NU	41,42,43	63	NU	42	51	62,63	NU	NU	61	NU	NU	51	NU	NU
RED		128			101			*		134								
YELLOW		129			102					135								
GREEN		130			103					136								
RED ARROW													A121			A114		
YELLOW ARROW						102	132						A122			A115		
FLASHING YELLOW ARROW													A123			A116		
GREEN ARROW						103	133	133										
Hand icon																		
Person icon																		

NU = Not Used  
 \* Denotes install load resistor. See load resistor installation detail this sheet.  
 ★ See pictorial of head wiring in detail this sheet.

### INPUT FILE POSITION LAYOUT

(front view)

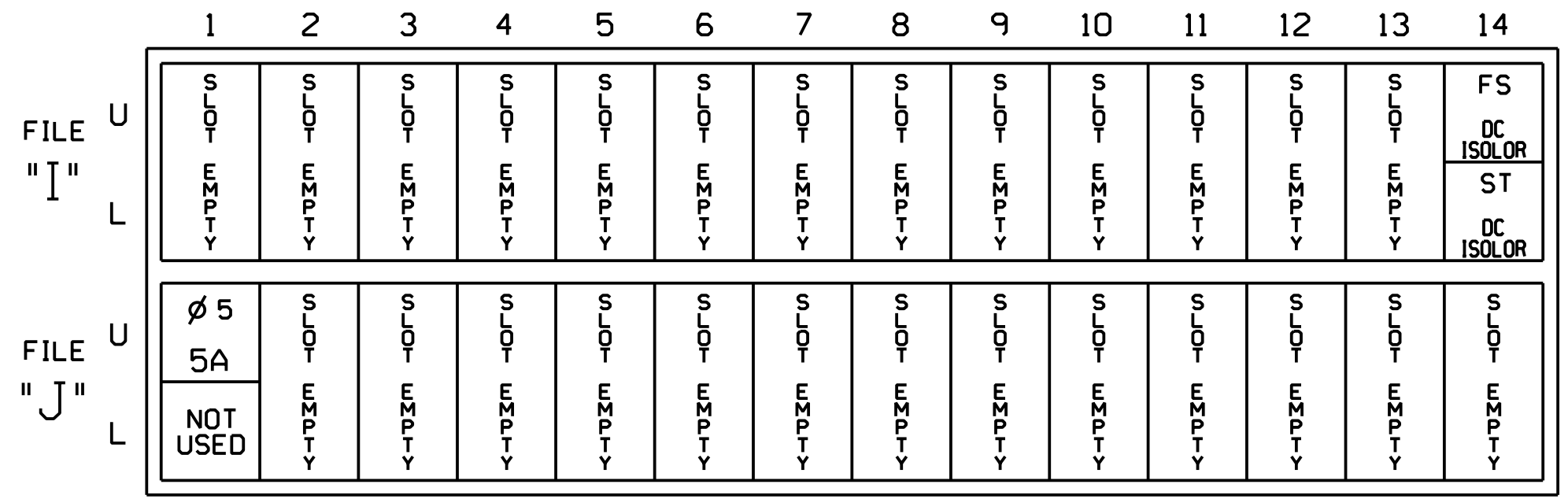

EX.: 1A, 2A, ETC. = LOOP NO.'S  
 FS = FLASH SENSE  
 ST = STOP TIME

### INPUT FILE CONNECTION & PROGRAMMING CHART

LOOP NO.	LOOP TERMINAL	INPUT FILE POS.	PIN NO.	INPUT ASSIGNMENT NO.	DETECTOR NO.	NEMA PHASE	CALL	EXTEND	FULL TIME DELAY	STRETCH TIME	DELAY TIME
5A	TB3-1,2	J1U	55	17	5	5	Y	Y			15
	-	14U	47	9 ★	22	2	Y	Y			
	-	J1U	55	17 ★	55	5	Y	Y			

\* See Input Page Assignment programming details on sheet 3.

#### INPUT FILE POSITION LEGEND: J2L

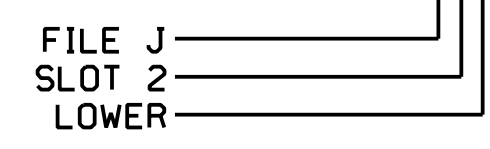

### FYA SIGNAL WIRING DETAIL

(wire signal heads as shown)

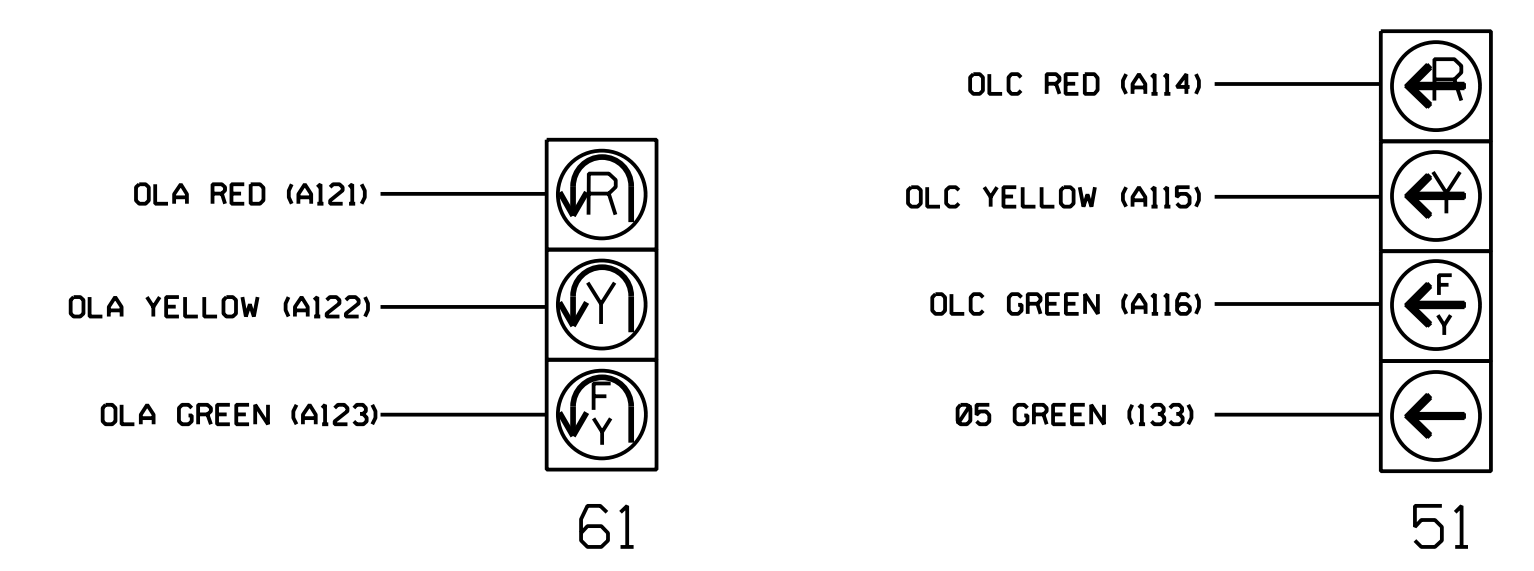

#### NOTE

The sequence display for signal head 51 requires special logic programming. See sheet 2 for programming instructions.

### SPECIAL DETECTOR NOTE

Install a multizone microwave detection system for vehicle detection. Perform installation according to manufacturer's directions and NCDOT engineer-approved mounting locations to accomplish detection schemes shown on the Signal Design Plans.

### LOAD RESISTOR INSTALLATION DETAIL

(install resistor as shown below)

ACCEPTABLE VALUES	
VALUE (ohms)	WTAGE
1.5K - 1.9K	25W (min)
2.0K - 3.0K	10W (min)

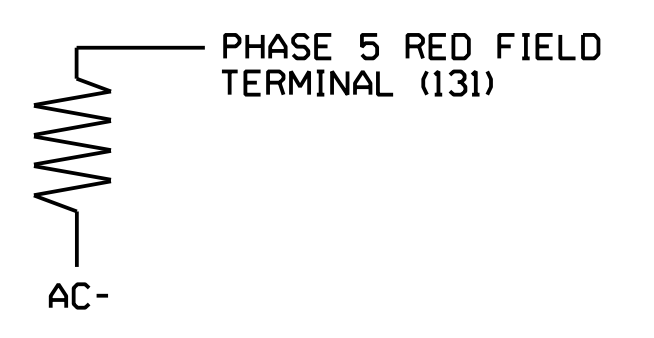

THIS ELECTRICAL DETAIL IS FOR THE SIGNAL DESIGN: 03-0840T2  
 DESIGNED: May 2022  
 SEALED: 5/17/2024  
 REVISED:

This plan supersedes the plan signed and sealed on 5/17/2024.

**HNTB**  
 HNTB NORTH CAROLINA, P.C.  
 343 E. Six Forks Road, Suite 200  
 Raleigh, North Carolina 27609  
 NC License No: C-1554  
 (919) 546-8997

Signal Upgrade-  
 Electrical Detail - Sheet 1 of 4  
 (Construction Phase 2A)

DOCUMENT NOT CONSIDERED FINAL UNLESS ALL SIGNATURES COMPLETED

ELECTRICAL AND PROGRAMMING DETAILS FOR:  Prepared in the Office of:  750 N. Greenfield Pkwy, Garner, NC 27529	SR 2048 (Gordon Rd) at SR 2117 (Harris Rd)	SEAL  ENGINEER NATASHA R. SIMMONS
	Division 3 New Hanover County Wilmington PLAN DATE: August 2023 REVIEWED BY: N.K. Vianich PREPARED BY: E.E. Tiller REVIEWED BY: N.R. Simmons	REVISIONS INIT. DATE



18 CHANNEL CONFLICT MONITOR PROGRAMMING DETAIL

(remove jumpers and set switches as shown)

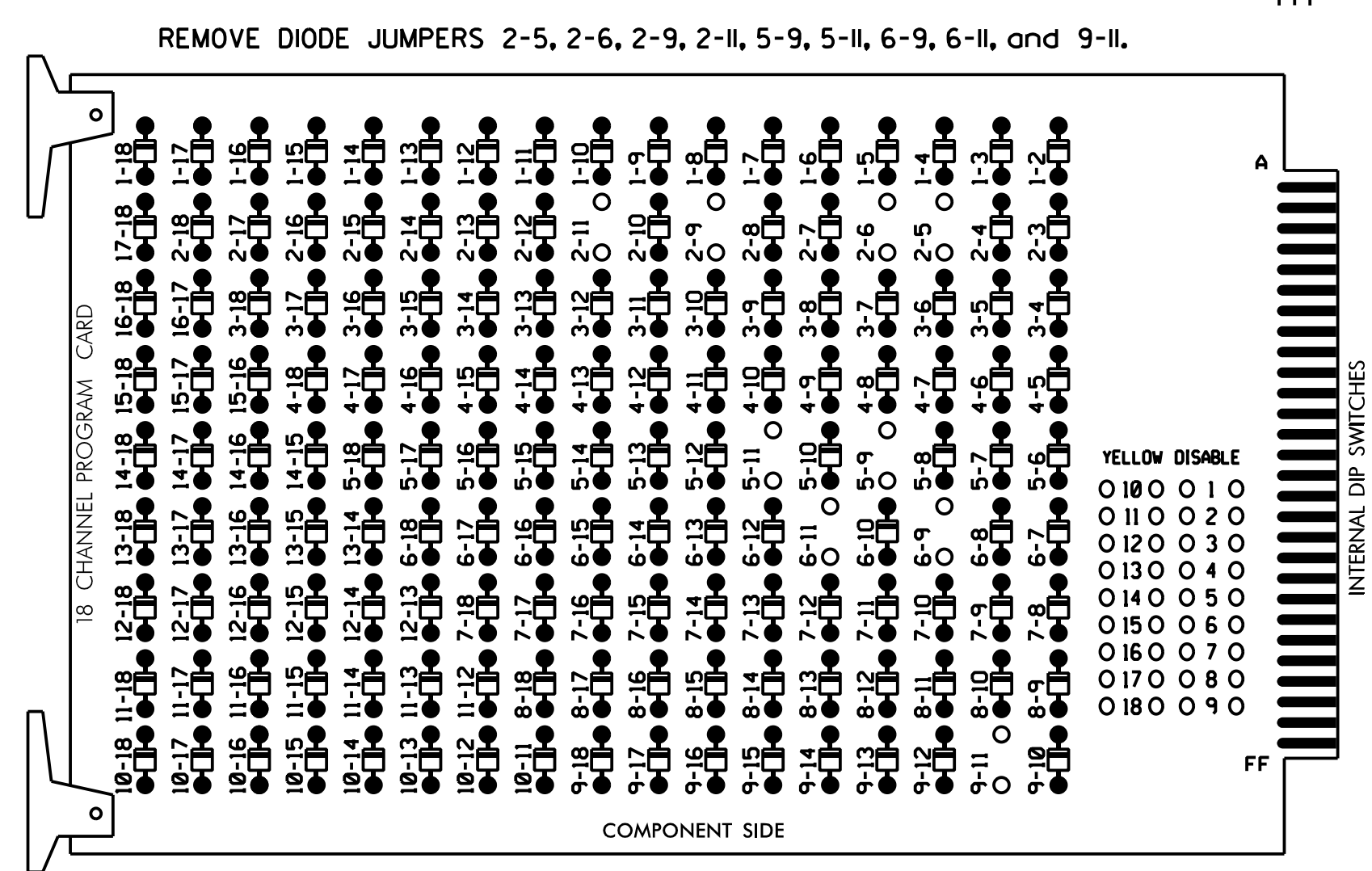

- NOTES: 1. Card is provided with all diode jumpers in place. Removal of any jumper allows its channels to run concurrently. 2. Ensure jumpers SEL2-SEL5 are present on the monitor board. 3. Ensure th Red Enable is active all times during normal operation. 4. Connect serial cable from conflict monitor to comm. port 1 of 2070 controller. Ensure conflict monitor communicates with 2070.

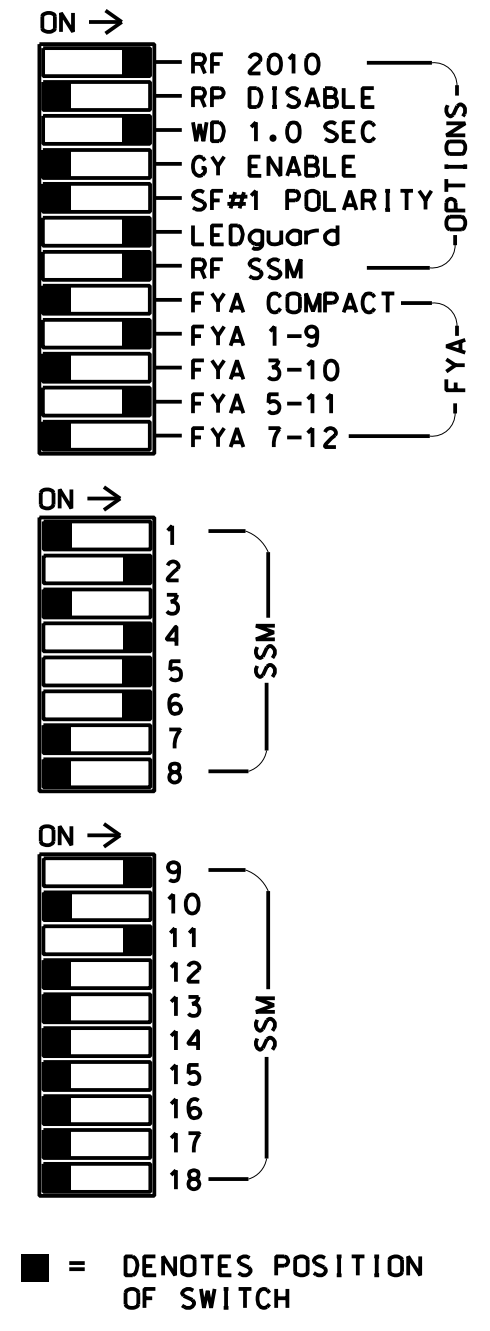
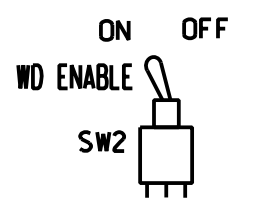

NOTES

- 1. To prevent "flash-conflict" problems, insert red flash program blocks for all unused vehicle load switches in the output file. The installer shall verify that signal heads flash in accordance with the Signal Plans. 2. Enable Simultaneous Gap-Out for all Phases. 3. Program phases 2 and 6 for Startup in Green. 4. Program phases 2 and 6 for Yellow Flash, and overlap 1 as Wag Overlap. 5. The cabinet and controller are part of the Wilmington Signal System.

EQUIPMENT INFORMATION

CONTROLLER.....2070 CABINET.....332 W/ AUX SOFTWARE.....ECONOLITE OASIS CABINET MOUNT.....BASE OUTPUT FILE POSITIONS...18 WITH AUX. OUTPUT FILE LOAD SWITCHES USED.....S2,S5,S7,S8,AUX S1,AUX S4 PHASES USED.....2,4,5,6 OVERLAP "A".....2 OVERLAP "B".....NOT USED OVERLAP "C".....5+6 OVERLAP "D".....NOT USED

SIGNAL HEAD HOOK-UP CHART

Table with columns for Load Switch No., CMU Channel No., Phase, Signal Head No., and various signal types (RED, YELLOW, GREEN, RED ARROW, YELLOW ARROW, FLASHING YELLOW ARROW, GREEN ARROW) across 18 channels.

NU = Not Used \* Denotes install load resistor. See load resistor installation detail this sheet. ★ See pictorial of head wiring in detail this sheet.

INPUT FILE POSITION LAYOUT

(front view)

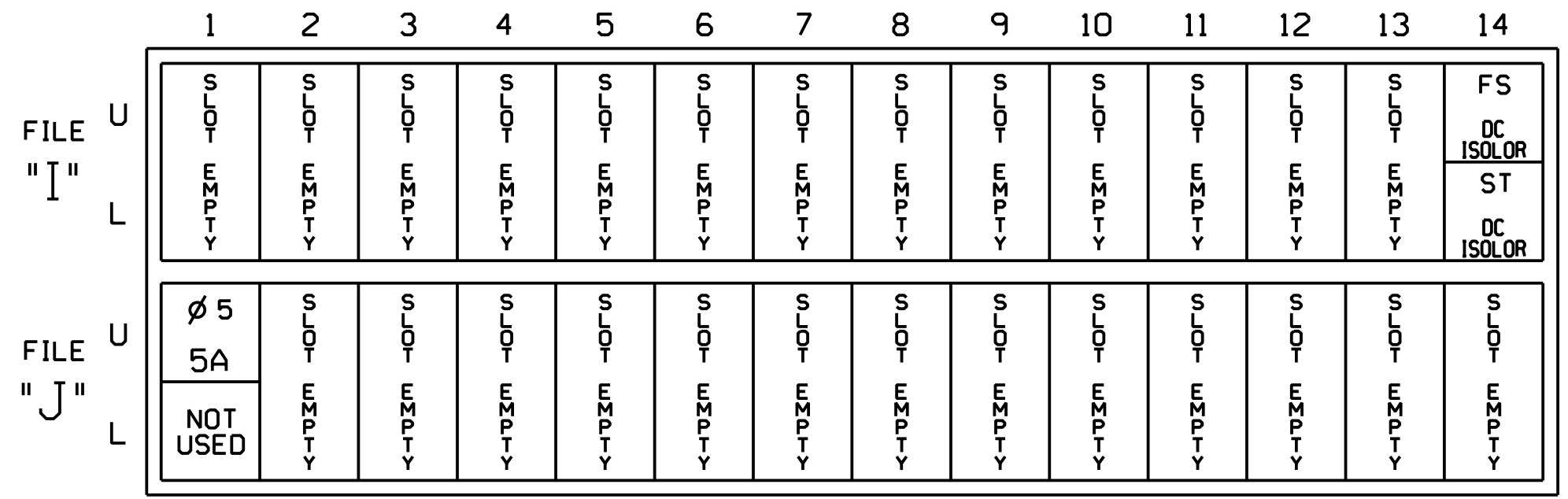

EX.: 1A, 2A, ETC. = LOOP NO.'S FS = FLASH SENSE ST = STOP TIME

INPUT FILE CONNECTION & PROGRAMMING CHART

Table with columns: LOOP NO., LOOP TERMINAL, INPUT FILE POS., PIN NO., INPUT ASSIGNMENT NO., DETECTOR NO., NEMA PHASE, CALL, EXTEND, FULL TIME DELAY, STRETCH TIME, DELAY TIME.

\* See Input Page Assignment programming details on sheet 3. INPUT FILE POSITION LEGEND: J2L FILE J SLOT 2 LOWER

FYA SIGNAL WIRING DETAIL

(wire signal heads as shown)

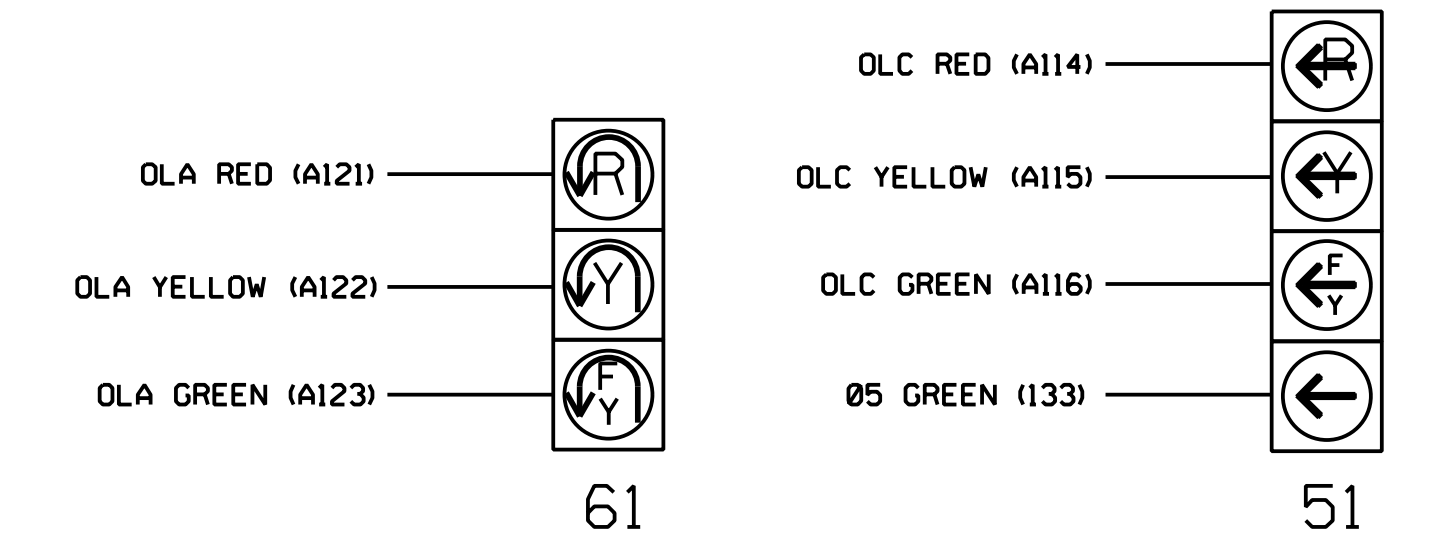

NOTE The sequence display for signal head 51 requires special logic programming. See sheet 2 for programming instructions.

SPECIAL DETECTOR NOTE

Install a multizone microwave detection system for vehicle detection. Perform installation according to manufacturer's directions and NCDOT engineer-approved mounting locations to accomplish detection schemes shown on the Signal Design Plans.

LOAD RESISTOR INSTALLATION DETAIL

(install resistor as shown below)

Table with columns: VALUE (ohms), WTAGE, 1.5K - 1.9K, 25W (min), 2.0K - 3.0K, 10W (min)

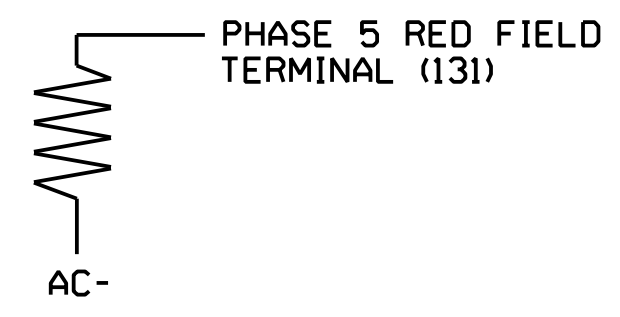

THIS ELECTRICAL DETAIL IS FOR THE SIGNAL DESIGN: 03-0840T3 DESIGNED: May 2022 SEALED: 5/17/2024 REVISED:

This plan supersedes the plan signed and sealed on 5/17/2024.

HNTB HNTB NORTH CAROLINA, P.C. 343 E. Six Forks Road, Suite 200 Raleigh, North Carolina 27609 NC License No: C-1554 (919) 546-8997

Signal Upgrade- Electrical Detail - Sheet 1 of 4 (Construction Phase 3)

DOCUMENT NOT CONSIDERED FINAL UNLESS ALL SIGNATURES COMPLETED

Professional seal and signature block for Natasha R. Simmons, North Carolina Professional Engineer, with project details for SR 2048 and SR 2117.



### 18 CHANNEL CONFLICT MONITOR PROGRAMMING DETAIL

(remove jumpers and set switches as shown)

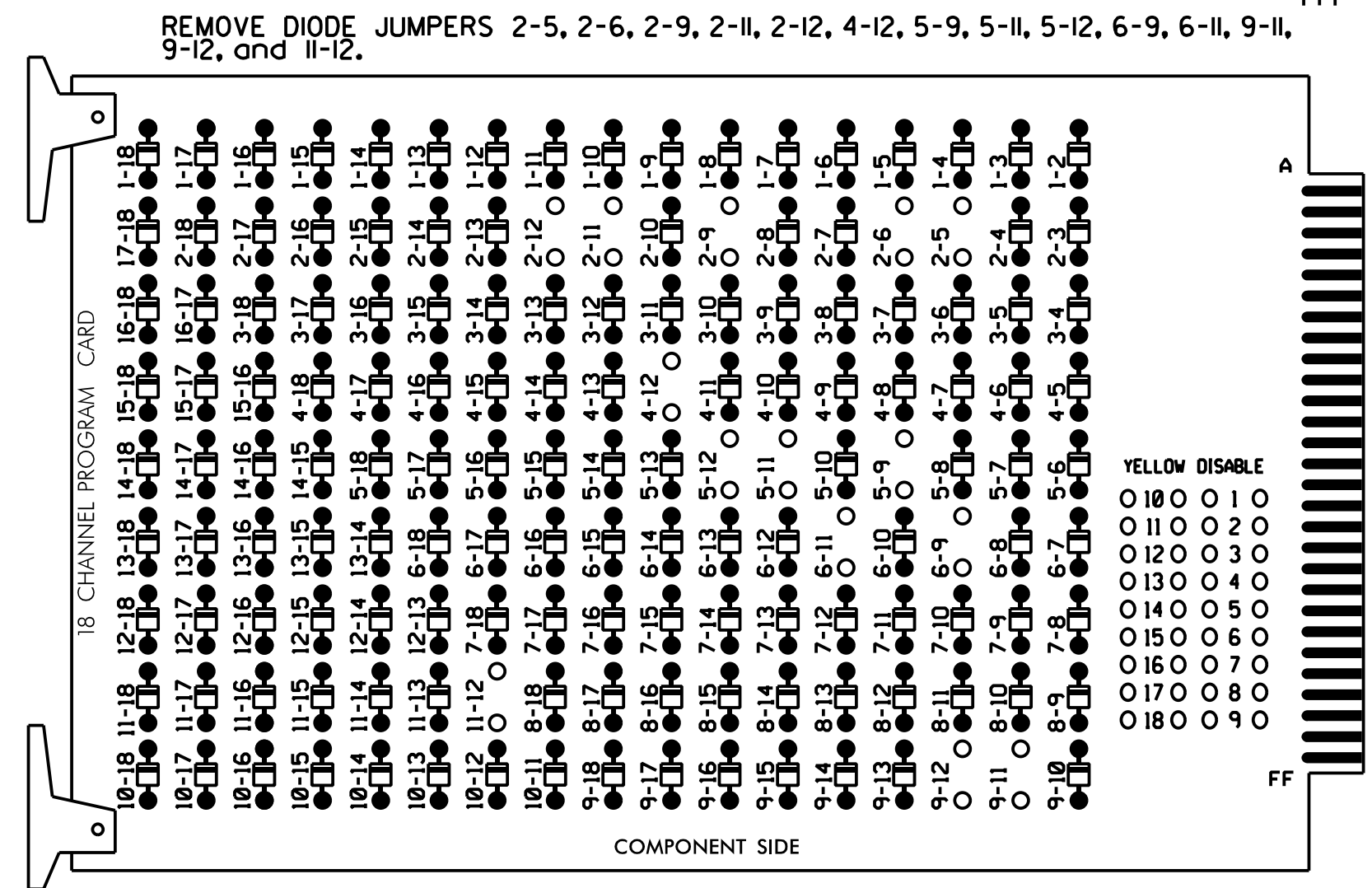

- REMOVE DIODE JUMPERS 2-5, 2-6, 2-9, 2-11, 2-12, 4-12, 5-9, 5-11, 5-12, 6-9, 6-11, 9-11, 9-12, and 11-12.
- REMOVE JUMPERS AS SHOWN
- NOTES:
- Card is provided with all diode jumpers in place. Removal of any jumper allows its channels to run concurrently.
  - Ensure jumpers SEL2-SEL5 are present on the monitor board.
  - Ensure th Red Enable is active all times during normal operation.
  - Connect serial cable from conflict monitor to comm. port 1 of 2070 controller. Ensure conflict monitor communicates with 2070.

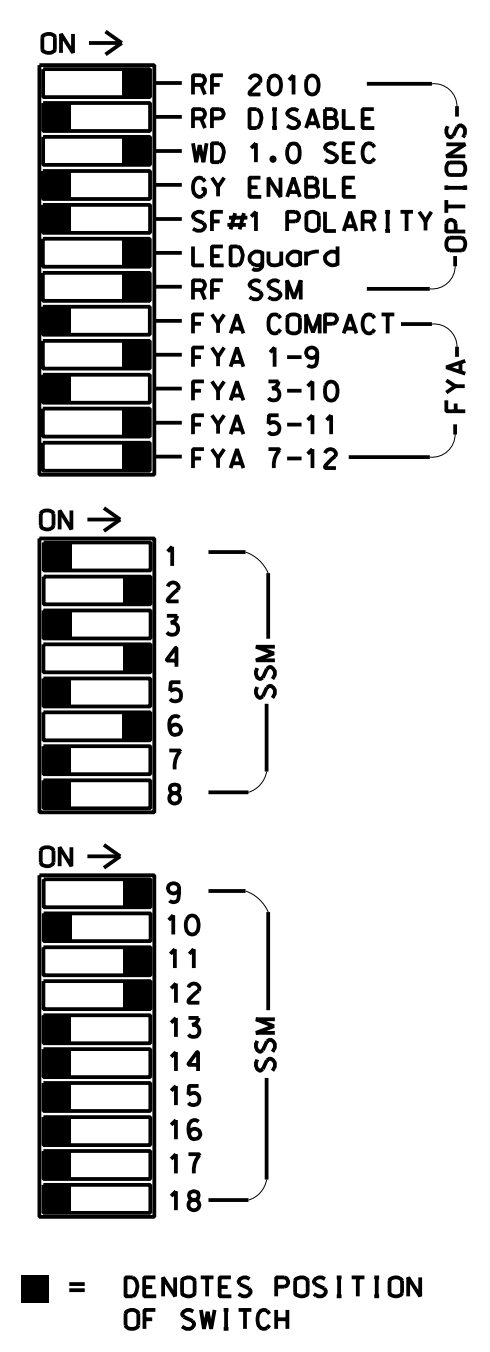

### NOTES

- To prevent "flash-conflict" problems, insert red flash program blocks for all unused vehicle load switches in the output file. The installer shall verify that signal heads flash in accordance with the Signal Plans.
- Enable Simultaneous Gap-Out for all Phases.
- Program phases 2 and 6 for Startup in Green.
- Program phases 2 and 6 for Yellow Flash, and overlaps 1 and 2 as Wag Overlaps.
- The cabinet and controller are part of the Wilmington Signal System.

### EQUIPMENT INFORMATION

CONTROLLER.....2070  
 CABINET.....332 W/ AUX  
 SOFTWARE.....ECONOLITE OASIS  
 CABINET MOUNT.....BASE  
 OUTPUT FILE POSITIONS...18 WITH AUX. OUTPUT FILE  
 LOAD SWITCHES USED.....S2,S5,S7,S8,AUX S1,AUX S4,AUX S5  
 PHASES USED.....2,4,5,6  
 OVERLAP "A".....2  
 OVERLAP "B".....NOT USED  
 OVERLAP "C".....5+6  
 OVERLAP "D".....4+5

### SIGNAL HEAD HOOK-UP CHART

LOAD SWITCH NO.	S1	S2	S3	S4	S5	S6	S7	S8	S9	S10	S11	S12	AUX S1	AUX S2	AUX S3	AUX S4	AUX S5	AUX S6
CMU CHANNEL NO.	1	2	13	3	4	14	5	6	15	7	8	16	9	10	17	11	12	18
PHASE	1	2	2 PED	3	4	4 PED	5	6	6 PED	7	8	8 PED	OLA	OLB	SPARE	OLC	OLD	SPARE
SIGNAL HEAD NO.	NU	21,22	NU	NU	41,43	63	NU	51	62,63	NU	NU	NU	61	NU	NU	51	42	NU
RED		128							134									A101
YELLOW		129						*	135									
GREEN		130							136									
RED ARROW					101								A121				A114	
YELLOW ARROW					102	102							A122				A115	A102
FLASHING YELLOW ARROW													A123				A116	A103
GREEN ARROW					103	103	133											
Hand																		
Person																		

NU = Not Used  
 \* Denotes install load resistor. See load resistor installation detail this sheet.  
 ★ See pictorial of head wiring in detail this sheet.

### INPUT FILE POSITION LAYOUT

(front view)

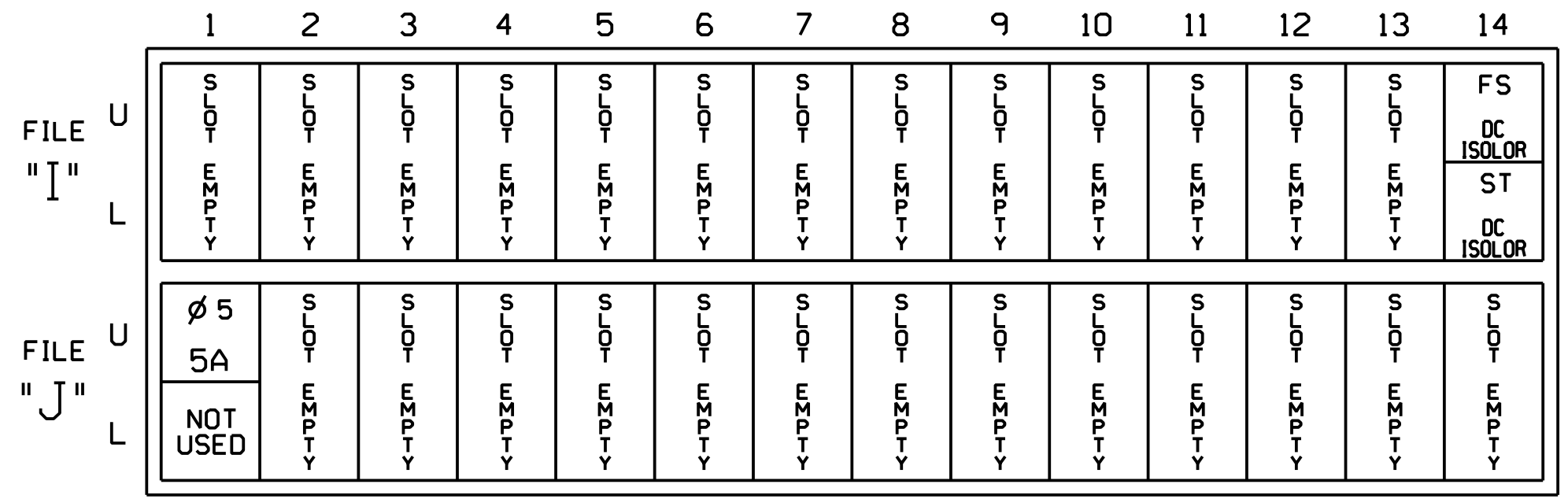

EX.: 1A, 2A, ETC. = LOOP NO.'S  
 FS = FLASH SENSE  
 ST = STOP TIME

### INPUT FILE CONNECTION & PROGRAMMING CHART

LOOP NO.	LOOP TERMINAL	INPUT FILE POS.	PIN NO.	INPUT ASSIGNMENT NO.	DETECTOR NO.	NEMA PHASE	CALL	EXTEND	FULL TIME DELAY	STRETCH TIME	DELAY TIME
5A	TB3-1,2	J1U	55	17	5	5	Y	Y			15
	-	14U	47	9 ★	22	2	Y	Y			
	-	J1U	55	17 ★	55	5	Y	Y			

\* See Input Page Assignment programming details on sheet 3.

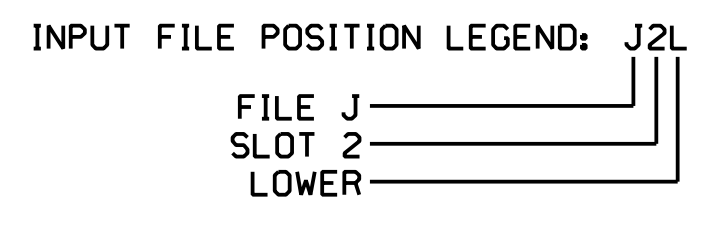

### FYA SIGNAL WIRING DETAIL

(wire signal heads as shown)

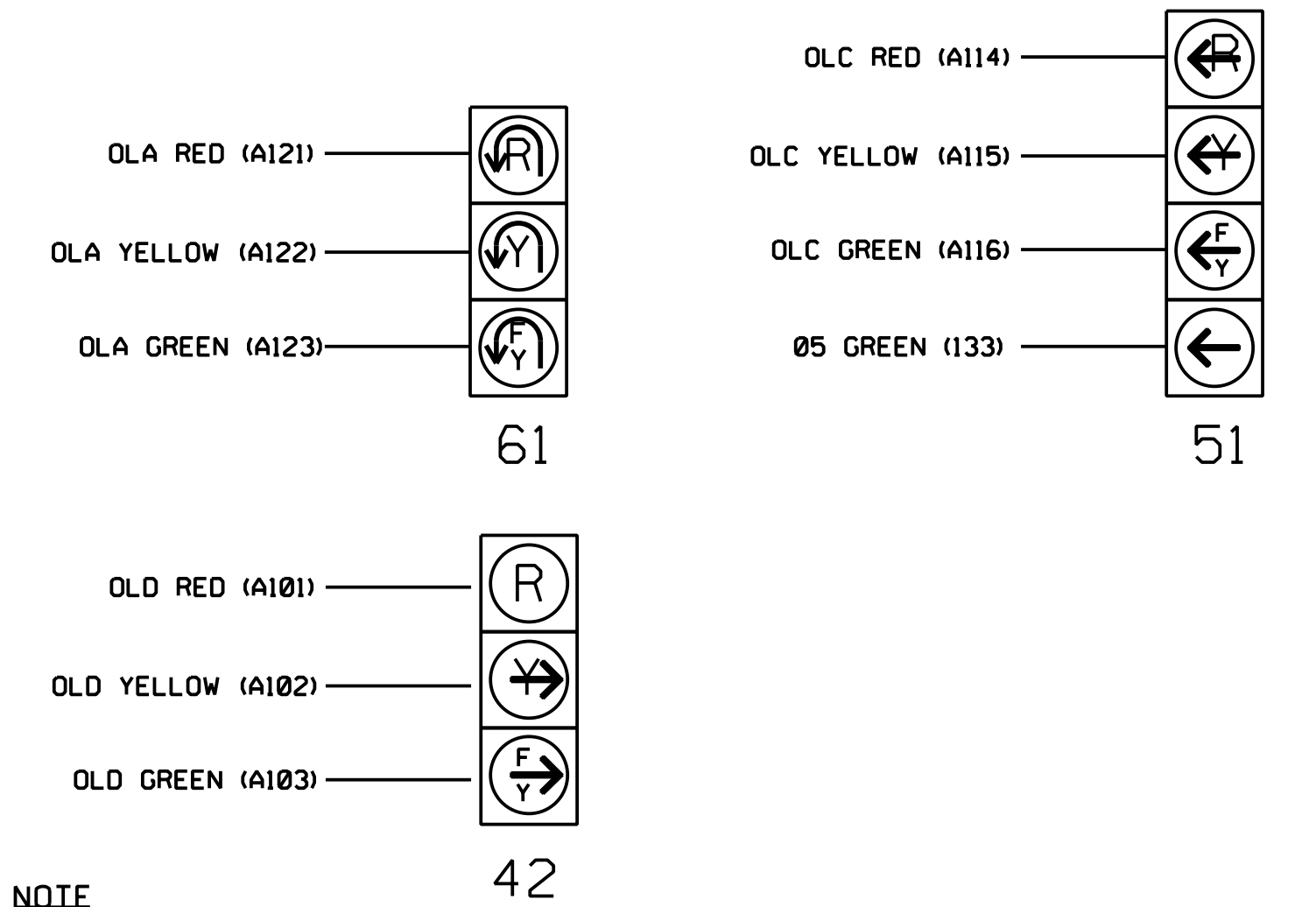

NOTE  
 The sequence display for signal head 51 requires special logic programming. See sheet 2 for programming instructions.

### LOAD RESISTOR INSTALLATION DETAIL

(install resistor as shown below)

ACCEPTABLE VALUES	
VALUE (ohms)	WTAGE
1.5K - 1.9K	25W (min)
2.0K - 3.0K	10W (min)

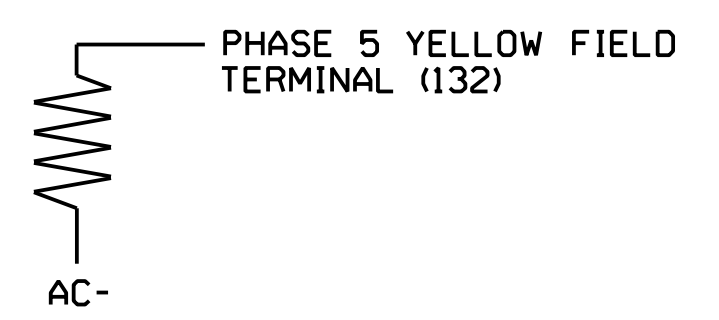

THIS ELECTRICAL DETAIL IS FOR THE SIGNAL DESIGN: 03-1216T1  
 DESIGNED: May 2022  
 SEALED: 5/17/2024  
 REVISED:

This plan supersedes the plan signed and sealed on 5/17/2024.

**HNTB**  
 HNTB NORTH CAROLINA, P.C.  
 343 E. Six Forks Road, Suite 200  
 Raleigh, North Carolina 27609  
 NC License No: C-1554  
 (919) 546-8997

DOCUMENT NOT CONSIDERED FINAL UNLESS ALL SIGNATURES COMPLETED

SR 2048 (Gordon Rd) at SR 2772 (Farrington Farms Dr)

Division 3 New Hanover County Wilmington

PLAN DATE: August 2023 REVIEWED BY: N.K. Vianich  
 PREPARED BY: E.E. Tiller REVIEWED BY: N.R. Simmons

REVISIONS: INIT. DATE

Signature: *Metasha R. Simmons* 11/8/2024  
 SEAL: NORTH CAROLINA PROFESSIONAL ENGINEER 031464  
 SIGNATURE: METASHA R. SIMMONS  
 DATE: 11/8/2024  
 SIG. INVENTORY NO. 03-1216T1



### 18 CHANNEL CONFLICT MONITOR PROGRAMMING DETAIL

(remove jumpers and set switches as shown)

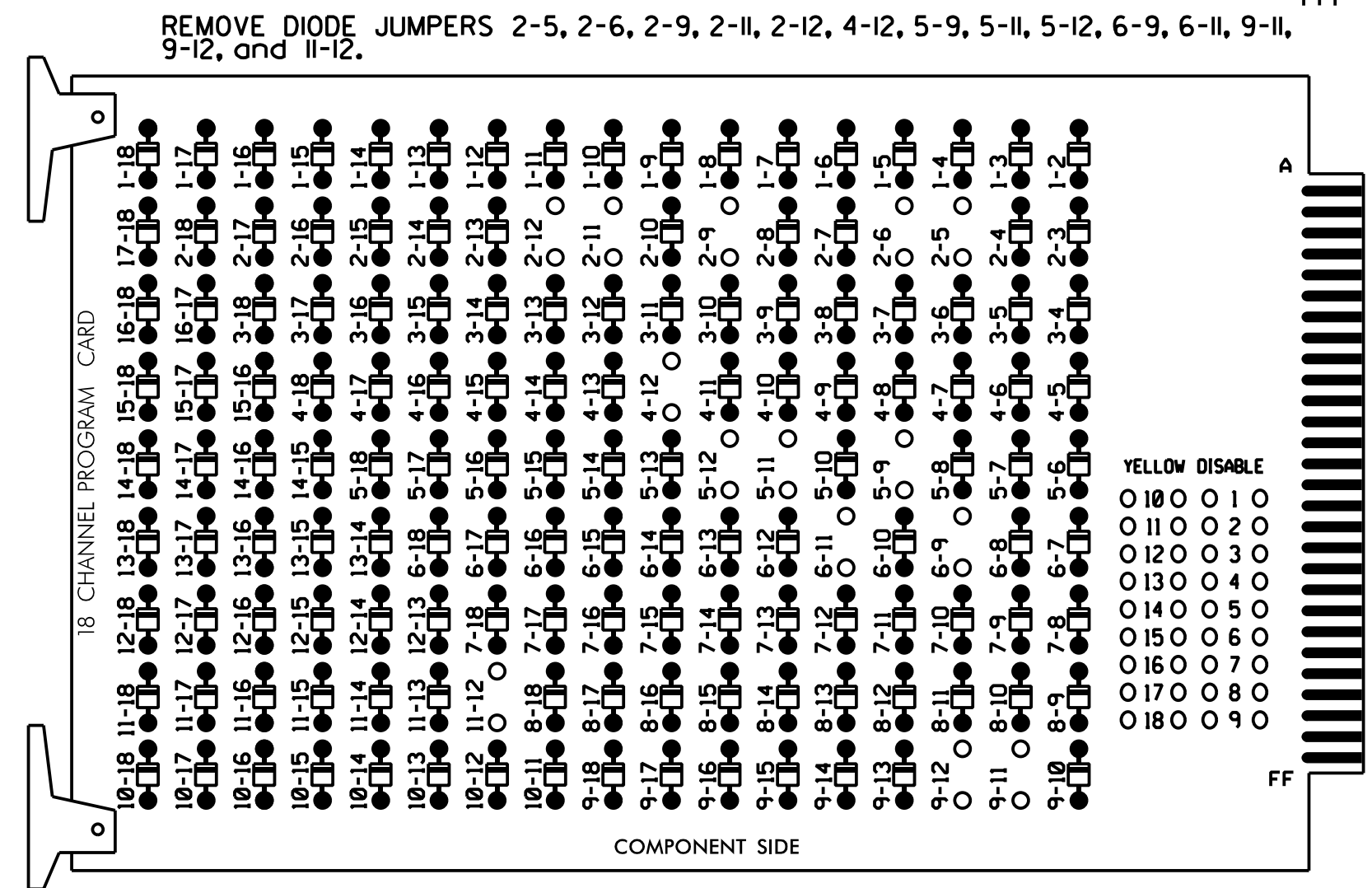

**NOTES:**

1. Card is provided with all diode jumpers in place. Removal of any jumper allows its channels to run concurrently.
2. Ensure jumpers SEL2-SEL5 are present on the monitor board.
3. Ensure th Red Enable is active all times during normal operation.
4. Connect serial cable from conflict monitor to comm. port 1 of 2070 controller. Ensure conflict monitor communicates with 2070.

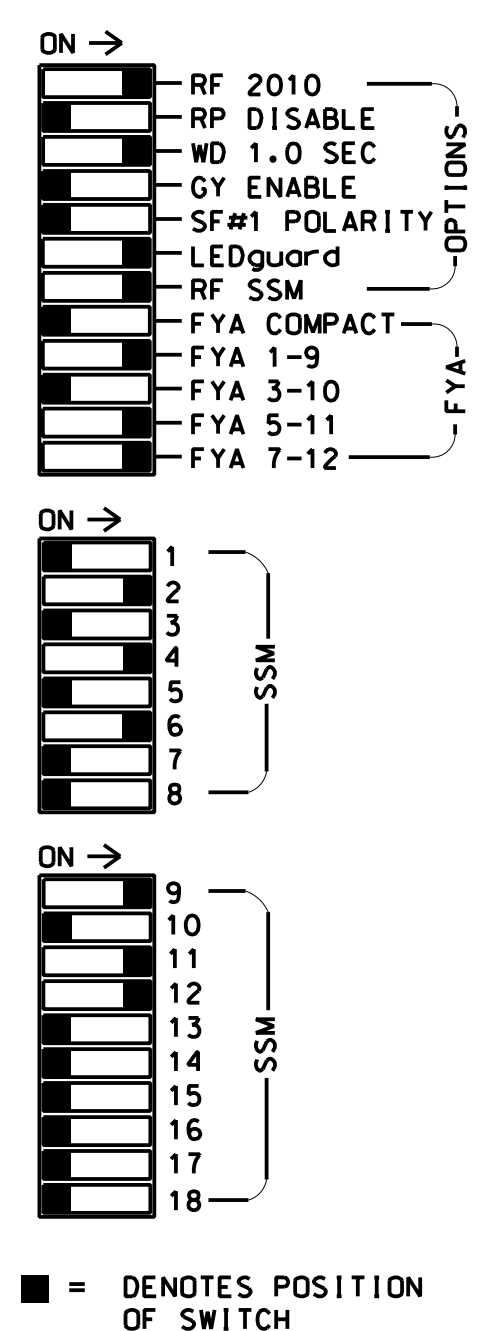

### NOTES

1. To prevent "flash-conflict" problems, insert red flash program blocks for all unused vehicle load switches in the output file. The installer shall verify that signal heads flash in accordance with the Signal Plans.
2. Enable Simultaneous Gap-Out for all Phases.
3. Program phases 2 and 6 for Startup in Green.
4. Program phases 2 and 6 for Yellow Flash, and overlaps 1 and 2 as a Wag Overlap.
5. The cabinet and controller are part of the Wilmington Signal System.

### EQUIPMENT INFORMATION

CONTROLLER.....2070  
 CABINET.....332 W/ AUX  
 SOFTWARE.....ECONOLITE OASIS  
 CABINET MOUNT.....BASE  
 OUTPUT FILE POSITIONS...18 WITH AUX. OUTPUT FILE  
 LOAD SWITCHES USED.....S2,S5,S7,S8,AUX S2,AUX S4,AUX S5  
 PHASES USED.....2,4,5,6  
 OVERLAP "A".....2  
 OVERLAP "B".....NOT USED  
 OVERLAP "C".....5+6  
 OVERLAP "D".....4+5

### SIGNAL HEAD HOOK-UP CHART

LOAD SWITCH NO.	S1	S2	S3	S4	S5	S6	S7	S8	S9	S10	S11	S12	AUX S1	AUX S2	AUX S3	AUX S4	AUX S5	AUX S6
CMU CHANNEL NO.	1	2	13	3	4	14	5	6	15	7	8	16	9	10	17	11	12	18
PHASE	1	2	2 PED	3	4	4 PED	5	6	6 PED	7	8	8 PED	OLA	OLB	SPARE	OLC	OLD	SPARE
SIGNAL HEAD NO.	NU	21,22	NU	NU	41,43	63	NU	51	62,63	NU	NU	NU	61	NU	NU	51	42	NU
RED		128								134								A101
YELLOW		129						*	135									
GREEN		130							136									
RED ARROW					101								A121			A114		
YELLOW ARROW					102	102							A122			A115	A102	
FLASHING YELLOW ARROW													A123			A116	A103	
GREEN ARROW					103	103	133											
Hand icon																		
Person icon																		

NU = Not Used  
 \* Denotes install load resistor. See load resistor installation detail this sheet.  
 ★ See pictorial of head wiring in detail this sheet.

### INPUT FILE POSITION LAYOUT

(front view)

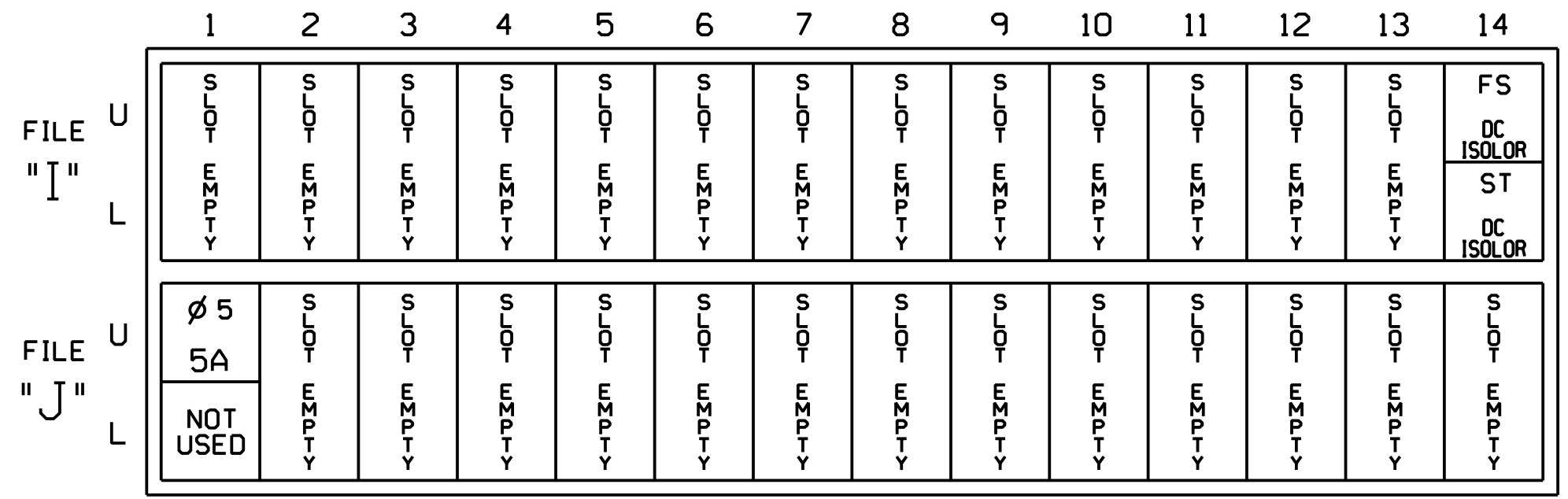

EX.: 1A, 2A, ETC. = LOOP NO.'S  
 FS = FLASH SENSE  
 ST = STOP TIME

### INPUT FILE CONNECTION & PROGRAMMING CHART

LOOP NO.	LOOP TERMINAL	INPUT FILE POS.	PIN NO.	INPUT ASSIGNMENT NO.	DETECTOR NO.	NEMA PHASE	CALL	EXTEND	FULL TIME DELAY	STRETCH TIME	DELAY TIME
5A	TB3-1,2	J1U	55	17	5	5	Y	Y			15
	-	14U	47	9 ★	22	2	Y	Y			
	-	J1U	55	17 ★	55	5	Y	Y			

\* See Input Page Assignment programming details on sheet 3.

#### INPUT FILE POSITION LEGEND: J2L

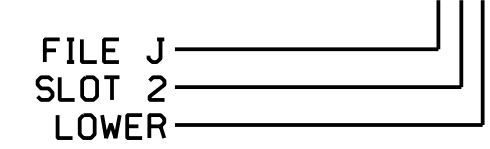

### FYA SIGNAL WIRING DETAIL

(wire signal heads as shown)

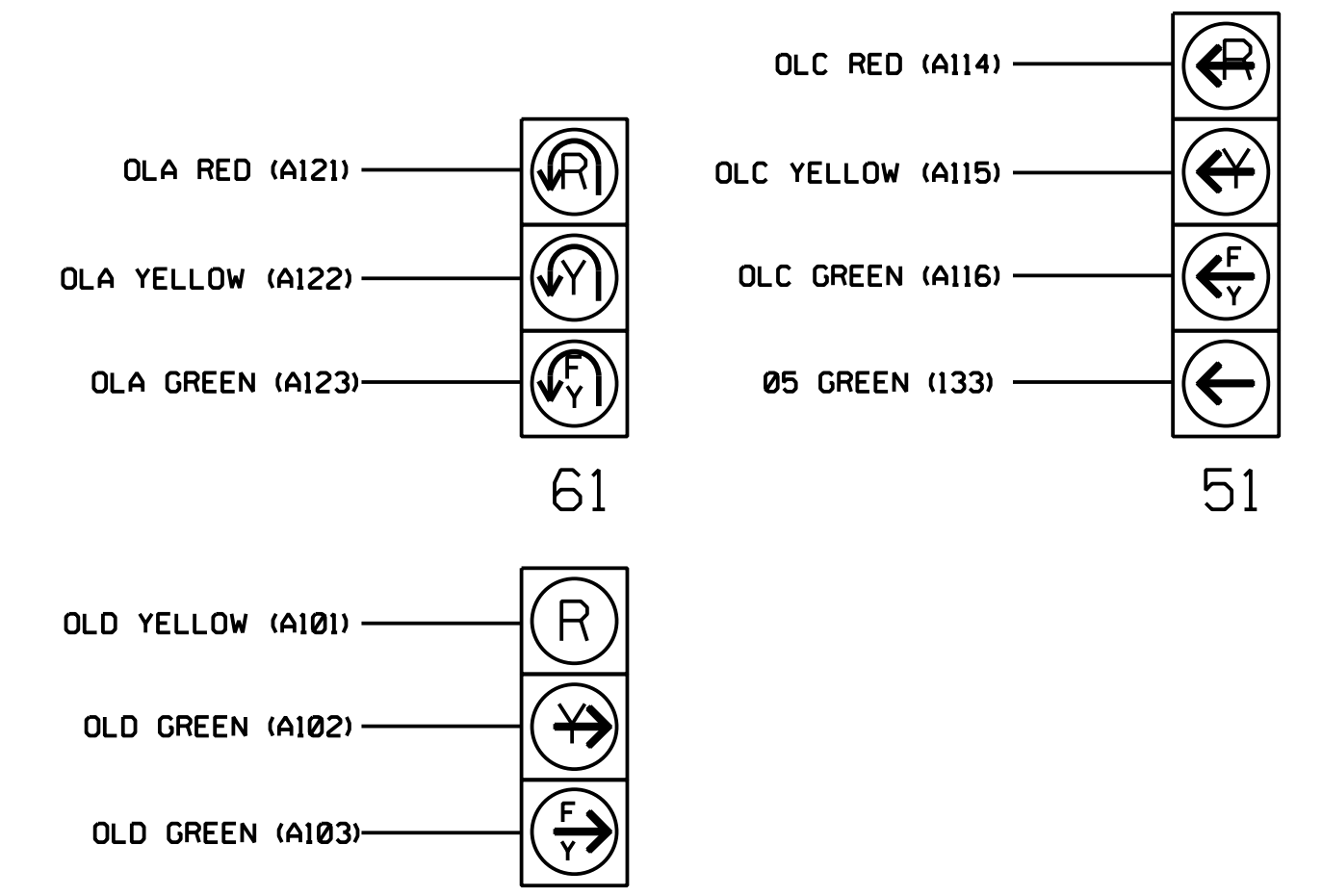

**NOTE**

The sequence display for signal head 51 requires special logic programming. See sheet 2 for programming instructions.

### SPECIAL DETECTOR NOTE

Install a multizone microwave detection system for vehicle detection. Perform installation according to manufacturer's directions and NCDOT engineer-approved mounting locations to accomplish detection schemes shown on the Signal Design Plans.

### LOAD RESISTOR INSTALLATION DETAIL

(install resistor as shown below)

ACCEPTABLE VALUES	
VALUE (ohms)	WTAGE
1.5K - 1.9K	25W (min)
2.0K - 3.0K	10W (min)

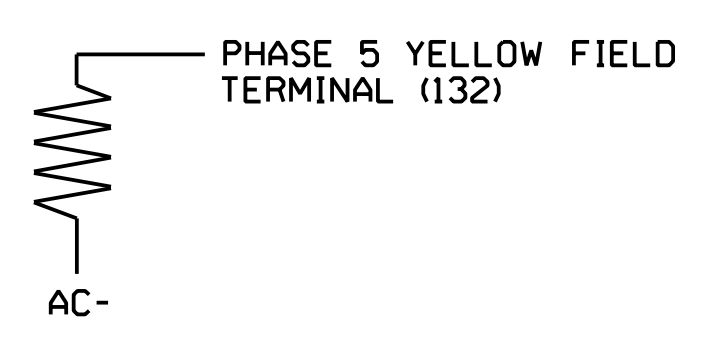

THIS ELECTRICAL DETAIL IS FOR THE SIGNAL DESIGN: 03-1216T2  
 DESIGNED: May 2022  
 SEALED: 5/17/2024  
 REVISED:

This plan supersedes the plan signed and sealed on 5/17/2024.

**HNTB**  
 HNTB NORTH CAROLINA, P.C.  
 343 E. Six Forks Road, Suite 200  
 Raleigh, North Carolina 27609  
 NC License No: C-1554  
 (919) 546-8997

Electrical and Programming Details For: SR 2048 (Gordon Rd) at SR 2772 (Farrington Farms Dr)

Division 3 New Hanover County Wilmington

PLAN DATE: August 2023 REVIEWED BY: N.K. Vianich  
 PREPARED BY: E.E. Tiller REVIEWED BY: N.R. Simmons

REVISIONS: INIT. DATE

Seal: NORTH CAROLINA PROFESSIONAL SEAL 031464 ENGINEER MATASHA R. SIMMONS

11/8/2024

SIG. INVENTORY NO. 03-1216T2



### 18 CHANNEL CONFLICT MONITOR PROGRAMMING DETAIL

(remove jumpers and set switches as shown)

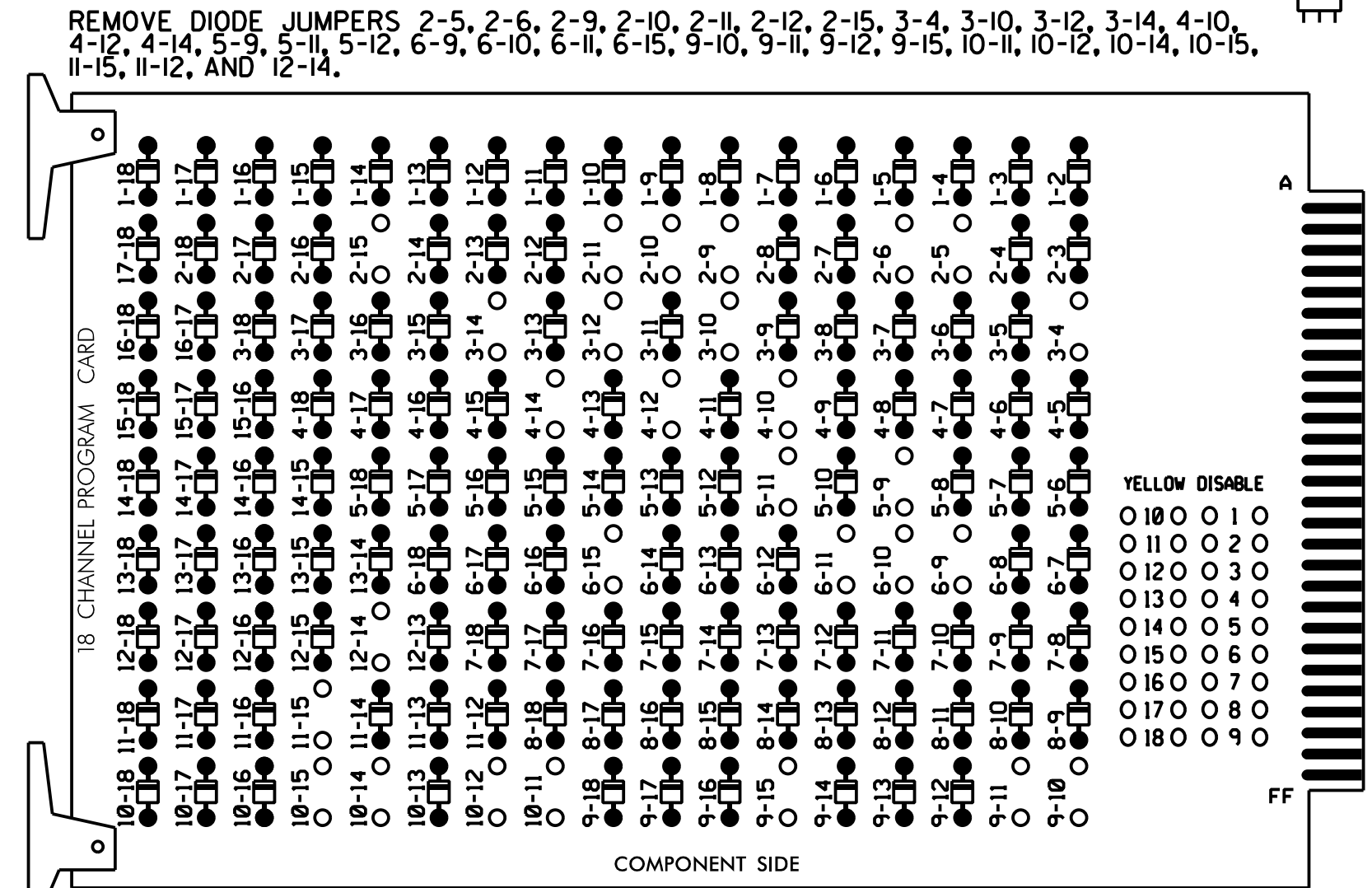

REMOVE JUMPERS AS SHOWN

#### NOTES:

- Card is provided with all diode jumpers in place. Removal of any jumper allows its channels to run concurrently.
- Ensure jumpers SEL2-SEL5 are present on the monitor board.
- Ensure th Red Enable is active all times during normal operation.
- Connect serial cable from conflict monitor to comm. port 1 of 2070 controller. Ensure conflict monitor communicates with 2070.

■ = DENOTES POSITION OF SWITCH

### NOTES

- To prevent "flash-conflict" problems, insert red flash program blocks for all unused vehicle load switches in the output file. The installer shall verify that signal heads flash in accordance with the Signal Plans.
- Enable Simultaneous Gap-Out for all Phases.
- Program phases 2 and 6 for Startup in Green.
- Program phases 2 and 6 for Yellow Flash, and overlaps 1 and 2 as Wag Overlaps.
- The cabinet and controller are part of the Wilmington Signal System.

### EQUIPMENT INFORMATION

CONTROLLER.....2070  
 CABINET.....332 W/ AUX  
 SOFTWARE.....ECONOLITE OASIS  
 CABINET MOUNT.....BASE  
 OUTPUT FILE POSITIONS...18 WITH AUX. OUTPUT FILE  
 LOAD SWITCHES USED.....S2,S4,S5,S6,S7,S8,S9,AUX S1,  
 AUX S2,AUX S4,AUX S5  
 PHASES USED.....2,4,5,6  
 OVERLAP "A".....2  
 OVERLAP "B".....4+6  
 OVERLAP "C".....5+6  
 OVERLAP "D".....4  
 OVERLAP "E".....NOT USED  
 OVERLAP "F".....NOT USED  
 OVERLAP "G".....4

### SIGNAL HEAD HOOK-UP CHART

LOAD SWITCH NO.	S1	S2	S3	S4	S5	S6	S7	S8	S9	S10	S11	S12	AUX S1	AUX S2	AUX S3	AUX S4	AUX S5	AUX S6
CMU CHANNEL NO.	1	2	13	3	4	14	5	6	15	7	8	16	9	10	17	11	12	18
PHASE	1	2	2 PED	OLG	4	4 PED	5	6	6 PED	7	8	8 PED	OLA	OLB	SPARE	OLC	OLD	SPARE
SIGNAL HEAD NO.	NU	21,22	NU	64	41,43	P41, P42	51	62,63	P61, P62	NU	NU	NU	61	64	NU	51	42	NU
RED		128						134						A124			A101	
YELLOW		129		*			*	135										
GREEN		130						136										
RED ARROW					101									A121			A114	
YELLOW ARROW					102									A122	A125		A115	A102
FLASHING YELLOW ARROW														A123	A126		A116	A103
GREEN ARROW					118	103		133										
Hand							104			119								
Person							106			121								

NU = Not Used

\* Denotes install load resistor. See load resistor installation detail this sheet.

★ See pictorial of head wiring in detail this sheet.

### INPUT FILE POSITION LAYOUT

(front view)

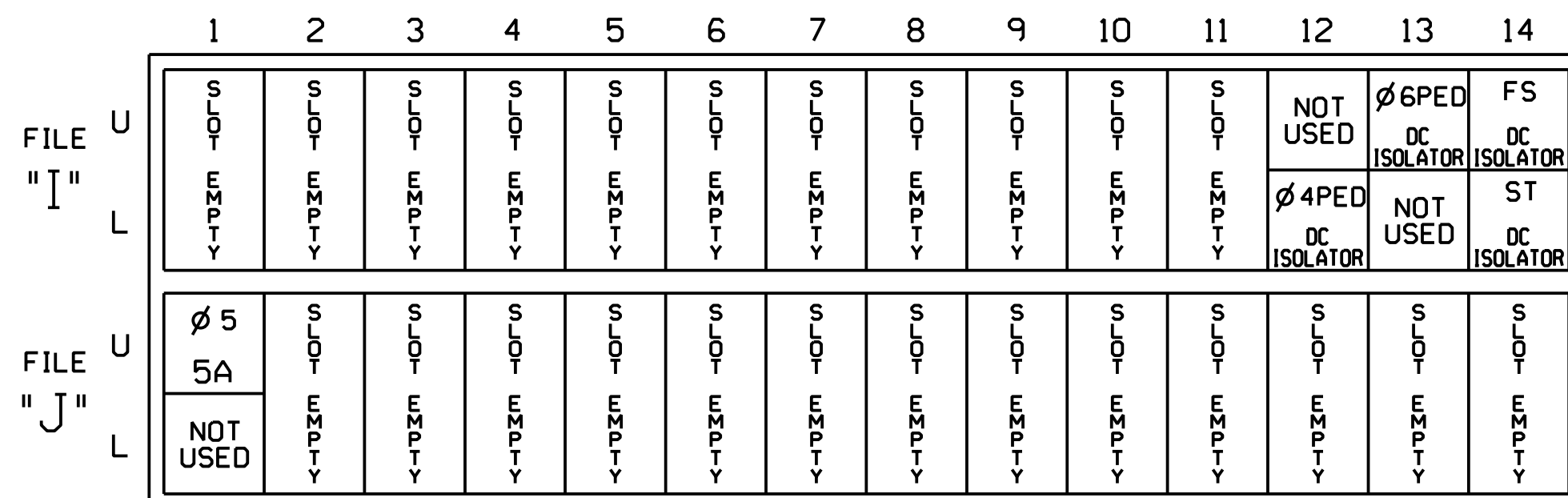

EX.: 1A, 2A, ETC. = LOOP NO.'S

FS = FLASH SENSE  
ST = STOP TIME

### INPUT FILE CONNECTION & PROGRAMMING CHART

LOOP NO.	LOOP TERMINAL	INPUT FILE POS.	PIN NO.	INPUT ASSIGNMENT NO.	DETECTOR NO.	NEMA PHASE	CALL	EXTEND	FULL TIME DELAY	STRETCH TIME	DELAY TIME
5A	TB3-1,2	J1U	55	17	5	5	Y	Y			15
	-	14U	47	9 ★	22	2	Y	Y			
PED PUSH BUTTONS		J1U	55	17 ★	55	5	Y	Y			
P41,P42	T88-5,6	I12L	69	31	PED 4	4 PED					
P61,P62	T88-7,9	I13U	68	30	PED 6	6 PED					

NOTE:  
INSTALL DC ISOLATORS IN INPUT FILE SLOTS 112 AND 113.

\* See Input Page Assignment programming details on sheet 3.

INPUT FILE POSITION LEGEND: J2L



### FYA SIGNAL WIRING DETAIL

(wire signal heads as shown)

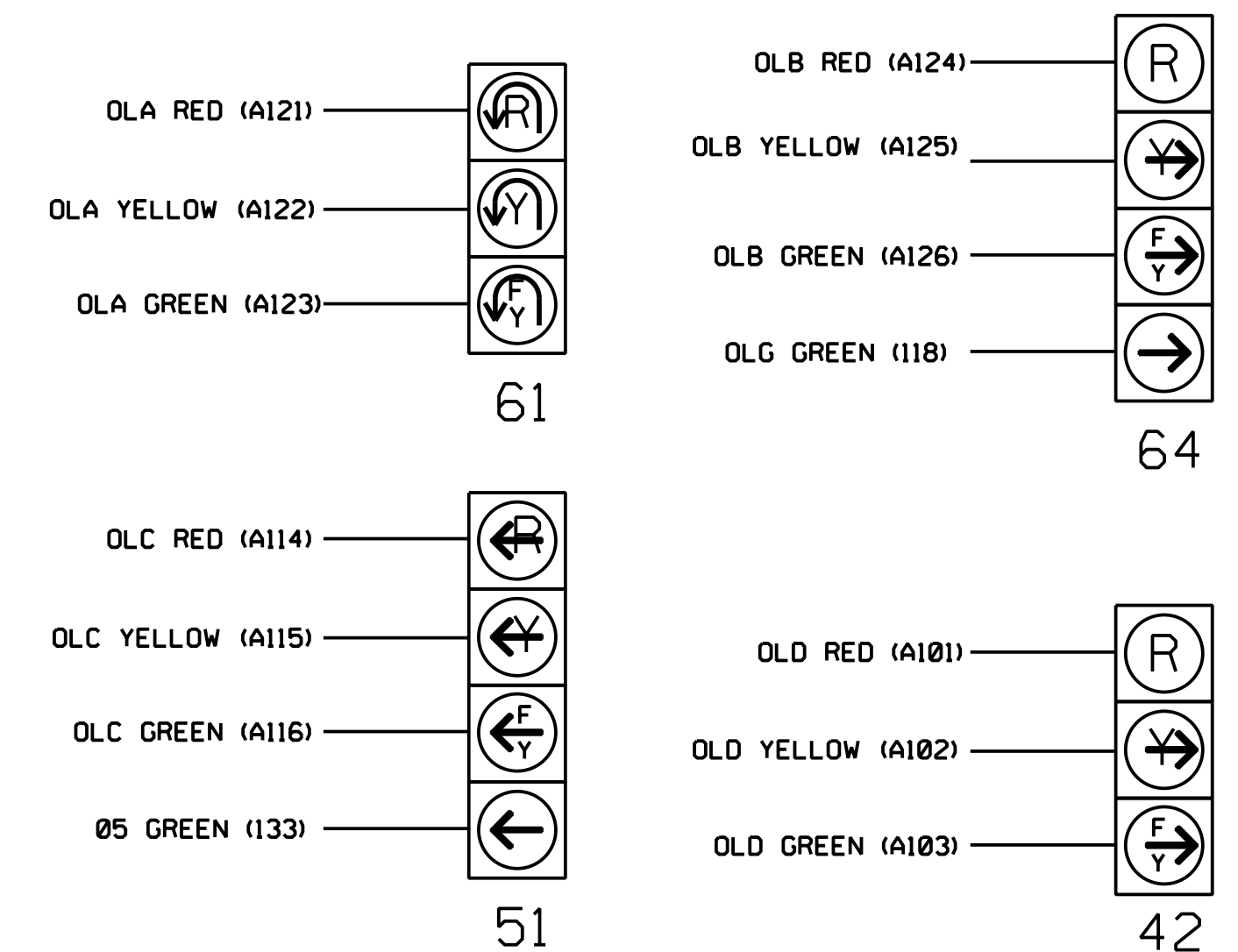

#### NOTE

The sequence display for signal heads 51 and 64 require special logic programming. See sheet 2 for programming instructions.

### LOAD RESISTOR INSTALLATION DETAIL

(install resistor as shown below)

VALUE (ohms)	WTAGE
1.5K - 1.9K	25W (min)
2.0K - 3.0K	10W (min)

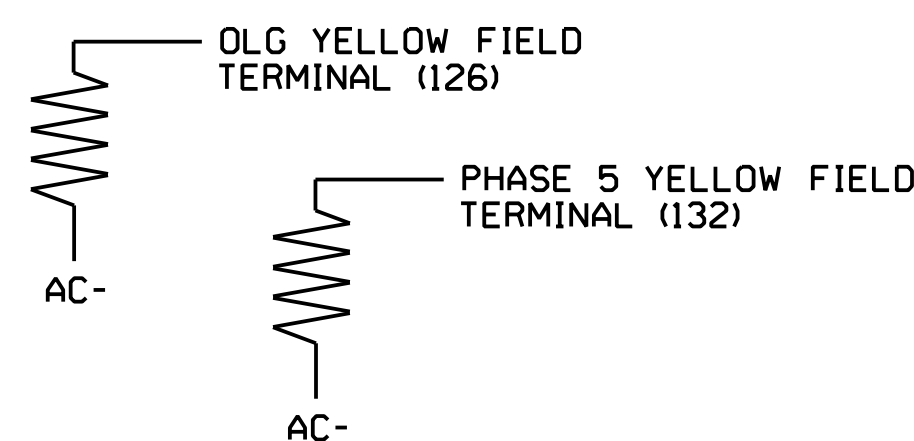

This plan supersedes the plan signed and sealed on 5/17/2024.

THIS ELECTRICAL DETAIL IS FOR THE SIGNAL DESIGN: 03-1216  
 DESIGNED: May 2022  
 SEALED: 5/17/2024  
 REVISED:



HNTB NORTH CAROLINA, P.C.  
 343 E. Six Forks Road, Suite 200  
 Raleigh, North Carolina 27609  
 NC License No: C-1554  
 (919) 546-8997

Signal Upgrade - Final Design  
Electrical Detail - Sheet 1 of 5

DOCUMENT NOT CONSIDERED FINAL UNLESS ALL SIGNATURES COMPLETED

ELECTRICAL AND PROGRAMMING DETAILS FOR: SR 2048 (Gordon Rd) at SR 2772 (Farrington Farms Dr)

Division 3 New Hanover County Wilmington

PLAN DATE: August 2023 REVIEWED BY: N.K. Vianich  
 PREPARED BY: E.E. Tiller REVIEWED BY: N.R. Simmons

REVISIONS: INIT. DATE

Prepared in the Office of:

11/8/2024  
 SIGNATURE: Natasha R. Simmons  
 DATE: 11/8/2024  
 SIG. INVENTORY NO. 03-1216