



STATE OF NORTH CAROLINA
DEPARTMENT OF TRANSPORTATION

JOSH STEIN
GOVERNOR

DANIEL H. JOHNSON
SECRETARY

December 10, 2025

Addendum No. 1

RE: Contract # C205018

WBS # 46860.3.1

STATE FUNDED

Rockingham County (I-5898)

UPGRADE FUTURE I-73/US-220 AT US-311/NC-135 INTERCHANGE AND
REPLACE BRIDGE #780074

December 16, 2025 Letting

To Whom It May Concern:

Reference is made to the plans and proposal furnished to you on this project.

The following revisions have been made to the Roadway Plans:

Sheet No.	Revision
2A-2	Typical Sections Nos. 3 & 4 revised to show sidewalk on only one side

Please void the above listed Sheet in your plans and staple the revised Sheet thereto.

The following revisions have been made to the Structure Plans:

Sheet No.	Revision
W-2	The line work directly in front of the end bent has been lowered to accurately represent the finished grade of the MSE wall. Labels have been added to clearly differentiate the proposed finished grade, top of wall/coping, and proposed bottom of wall. MSE wall areas have been revised to reflect the elevation changes in front of the end bent.

Please void the above listed Sheet in your plans and staple the revised Sheet thereto.

The following revisions have been made to the proposal:

Page No.	Revision
Proposal Cover	Note added that reads "Includes Addendum No. 1 Dated 12-10-2025".

Please void the above listed Page in your proposal and staple the revised Page thereto.

On the item sheets the following pay item revisions have been made:

<u>Item</u>	<u>Description</u>	<u>Old Quantity</u>	<u>New Quantity</u>
0247 - 8801000000-E SP	MSE RETAINING WALL NO 1	3,941 SF	3,221 SF
0248 - 8801000000-E SP	MSE RETAINING WALL NO 2	3,658 SF	2,915 SF

The Contractor's bid must include these pay item revisions.

The electronic bidding file has been updated to reflect these revisions. Please download the Addendum File and follow the instructions for applying the addendum. Bid Express will not accept your bid unless the addendum has been applied.

The contract will be prepared accordingly.

Sincerely,

Signed by:

 52C46046381F443...

Ronald E. Davenport, Jr., PE
 State Contract Officer

RED/jjr
 Attachments

cc: Mr. Wiley W. Jones III, PE
 Mr. Wright R. Archer, III, PE
 Mr. Ken Kennedy, PE
 Mr. Malcolm Bell
 Mr. Forrest Dungan, PE
 Ms. Jaci Kincaid
 Mr. Jon Weathersbee, PE
 Project File (2)

STATE OF NORTH CAROLINA
DEPARTMENT OF TRANSPORTATION
RALEIGH, N.C.

PROPOSAL

INCLUDES ADDENDUM No.1 DATED 12-10-2025

DATE AND TIME OF BID OPENING: **Dec 16, 2025 AT 02:00 PM**

CONTRACT ID C205018
WBS 46860.3.1

FEDERAL-AID NO. STATE FUNDED
COUNTY ROCKINGHAM
T.I.P NO. I-5898
MILES 0.514
ROUTE NO. I-73
LOCATION UPGRADE FUTURE I-73/US-220 AT US-311/NC-135 INTERCHANGE AND
REPLACE BRIDGE #780074.

TYPE OF WORK GRADING, DRAINAGE, PAVING, SIGNALS, AND STRUCTURES.

NOTICE:

ALL BIDDERS SHALL COMPLY WITH ALL APPLICABLE LAWS REGULATING THE PRACTICE OF GENERAL CONTRACTING AS CONTAINED IN CHAPTER 87 OF THE GENERAL STATUTES OF NORTH CAROLINA WHICH REQUIRES THE BIDDER TO BE LICENSED BY THE N.C. LICENSING BOARD FOR CONTRACTORS WHEN BIDDING ON ANY NON-FEDERAL AID PROJECT WHERE THE BID IS \$30,000 OR MORE, EXCEPT FOR CERTAIN SPECIALTY WORK AS DETERMINED BY THE LICENSING BOARD. BIDDERS SHALL ALSO COMPLY WITH ALL OTHER APPLICABLE LAWS REGULATING THE PRACTICES OF ELECTRICAL, PLUMBING, HEATING AND AIR CONDITIONING AND REFRIGERATION CONTRACTING AS CONTAINED IN CHAPTER 87 OF THE GENERAL STATUTES OF NORTH CAROLINA. NOTWITHSTANDING THESE LIMITATIONS ON BIDDING, THE BIDDER WHO IS AWARDED ANY FEDERAL - AID FUNDED PROJECT SHALL COMPLY WITH CHAPTER 87 OF THE GENERAL STATUTES OF NORTH CAROLINA FOR LICENSING REQUIREMENTS WITHIN 60 CALENDAR DAYS OF BID OPENING.

BIDS WILL BE RECEIVED AS SHOWN BELOW:

THIS IS A ROADWAY & STRUCTURE PROPOSAL

5% BID BOND OR BID DEPOSIT REQUIRED

County: ROCKINGHAM

Line #	Item Number	Sec #	Description	Quantity	Unit Cost	Amount
ROADWAY ITEMS						
0001	0000100000-N	800	MOBILIZATION	Lump Sum	L.S.	
0002	0000400000-N	801	CONSTRUCTION SURVEYING	Lump Sum	L.S.	
0003	0001000000-E	200	CLEARING & GRUBBING .. ACRE(S)	Lump Sum	L.S.	
0004	0008000000-E	200	SUPPLEMENTARY CLEARING & GRUBBING	1 ACR		
0005	0015000000-N	205	SEALING ABANDONED WELLS	2 EA		
0006	0022000000-E	225	UNCLASSIFIED EXCAVATION	5,200 CY		
0007	0036000000-E	225	UNDERCUT EXCAVATION	4,250 CY		
0008	0106000000-E	230	BORROW EXCAVATION	74,000 CY		
0009	0134000000-E	240	DRAINAGE DITCH EXCAVATION	61.9 CY		
0010	0156000000-E	250	REMOVAL OF EXISTING ASPHALT PAVEMENT	1,030 SY		
0011	0177000000-E	250	BREAKING OF EXISTING ASPHALT PAVEMENT	1,030 SY		
0012	0195000000-E	265	SELECT GRANULAR MATERIAL	4,050 CY		
0013	0196000000-E	270	GEOTEXTILE FOR SOIL STABILIZATION	5,550 SY		
0014	0199000000-E	SP	TEMPORARY SHORING	1,915 SF		
0015	0223000000-E	275	ROCK PLATING	180 SY		
0016	0248000000-N	SP	GENERIC GRADING ITEM TYPE 2 BRIDGE APPROACH FILL, STATION 119+69.55 -Y-	Lump Sum	L.S.	
0017	0318000000-E	300	FOUNDATION CONDITIONING MATERIAL, MINOR STRUCTURES	390 TON		

County: ROCKINGHAM

Line #	Item Number	Sec #	Description	Quantity	Unit Cost	Amount
0018	0321000000-E	300	FOUNDATION CONDITIONING GEOTEXTILE	1,210 SY		
0019	0335200000-E	305	15" DRAINAGE PIPE	36 LF		
0020	0335850000-E	305	*** DRAINAGE PIPE ELBOWS (15")	2 EA		
0021	0448000000-E	310	***** RC PIPE CULVERTS, CLASS IV (54")	244 LF		
0022	0448200000-E	310	15" RC PIPE CULVERTS, CLASS IV	1,520 LF		
0023	0448300000-E	310	18" RC PIPE CULVERTS, CLASS IV	1,268 LF		
0024	0448400000-E	310	24" RC PIPE CULVERTS, CLASS IV	164 LF		
0025	0448500000-E	310	30" RC PIPE CULVERTS, CLASS IV	192 LF		
0026	0448700000-E	310	42" RC PIPE CULVERTS, CLASS IV	196 LF		
0027	0986000000-E	SP	GENERIC PIPE ITEM 42" PIPE REHABILITATION CIPP LINER	252 LF		
0028	0986000000-E	SP	GENERIC PIPE ITEM PRE INSTALLATION INSPECTION	252 LF		
0029	0995000000-E	340	PIPE REMOVAL	1,537 LF		
0030	1011000000-N	500	FINE GRADING	Lump Sum	L.S.	
0031	1099500000-E	505	SHALLOW UNDERCUT	1,480 CY		
0032	1099700000-E	505	CLASS IV SUBGRADE STABILIZATION	2,805 TON		
0033	1110000000-E	510	STABILIZER AGGREGATE	100 TON		
0034	1112000000-E	505	GEOTEXTILE FOR SUBGRADE STABILIZATION	6,230 SY		

County: ROCKINGHAM

Line #	Item Number	Sec #	Description	Quantity	Unit Cost	Amount
0035	1121000000-E	520	AGGREGATE BASE COURSE	104 TON		
0036	1220000000-E	545	INCIDENTAL STONE BASE	100 TON		
0037	1297000000-E	607	MILLING ASPHALT PAVEMENT, **** DEPTH (1-1/2")	5,490 SY		
0038	1297000000-E	607	MILLING ASPHALT PAVEMENT, **** DEPTH (3")	1,930 SY		
0039	1308000000-E	607	MILLING ASPHALT PAVEMENT, **** TO ***** (0" TO 1-1/2")	1,210 SY		
0040	1330000000-E	607	INCIDENTAL MILLING	100 SY		
0041	1491000000-E	610	ASPHALT CONC BASE COURSE, TYPE B25.0C	7,710 TON		
0042	1503000000-E	610	ASPHALT CONC INTERMEDIATE COURSE, TYPE I19.0C	7,250 TON		
0043	1523000000-E	610	ASPHALT CONC SURFACE COURSE, TYPE S9.5C	6,140 TON		
0044	1575000000-E	620	ASPHALT BINDER FOR PLANT MIX	1,065 TON		
0045	1693000000-E	654	ASPHALT PLANT MIX, PAVEMENT REPAIR	100 TON		
0046	2022000000-E	815	SUBDRAIN EXCAVATION	67.2 CY		
0047	2026000000-E	815	GEOTEXTILE FOR SUBSURFACE DRAINS	300 SY		
0048	2036000000-E	815	SUBDRAIN COARSE AGGREGATE	50.4 CY		
0049	2044000000-E	815	6" PERFORATED SUBDRAIN PIPE	300 LF		
0050	2070000000-N	815	SUBDRAIN PIPE OUTLET	1 EA		
0051	2077000000-E	815	6" OUTLET PIPE	6 LF		

County: ROCKINGHAM

Line #	Item Number	Sec #	Description	Quantity	Unit Cost	Amount
0052	2209000000-E	838	ENDWALLS	2.086 CY		
0053	2220000000-E	838	REINFORCED ENDWALLS	10 CY		
0054	2253000000-E	840	PIPE COLLARS	3.872 CY		
0055	2275000000-E	SP	FLOWABLE FILL	38 CY		
0056	2286000000-N	840	MASONRY DRAINAGE STRUCTURES	58 EA		
0057	2297000000-E	840	MASONRY DRAINAGE STRUCTURES	14 CY		
0058	2308000000-E	840	MASONRY DRAINAGE STRUCTURES	66 LF		
0059	2364000000-N	840	FRAME WITH TWO GRATES, STD 840.16	2 EA		
0060	2364200000-N	840	FRAME WITH TWO GRATES, STD 840.20	1 EA		
0061	2365000000-N	840	FRAME WITH TWO GRATES, STD 840.22	5 EA		
0062	2366000000-N	840	FRAME WITH TWO GRATES, STD 840.24	1 EA		
0063	2374000000-N	840	FRAME WITH GRATE & HOOD, STD 840.03, TYPE ** (E)	10 EA		
0064	2374000000-N	840	FRAME WITH GRATE & HOOD, STD 840.03, TYPE ** (F)	24 EA		
0065	2374000000-N	840	FRAME WITH GRATE & HOOD, STD 840.03, TYPE ** (G)	14 EA		
0066	2396000000-N	840	FRAME WITH COVER, STD 840.54	8 EA		
0067	2440000000-N	852	CONCRETE TRANSITIONAL SECTION FOR CATCH BASIN	10 EA		
0068	2451000000-N	852	CONCRETE TRANSITIONAL SECTION FOR DROP INLET	1 EA		

County: ROCKINGHAM

Line #	Item Number	Sec #	Description	Quantity	Unit Cost	Amount
0069	2472000000-N	840	GENERIC DRAINAGE ITEM FRAME WITH COVER, STD 840.55	1 EA		
0070	2473000000-N	SP	GENERIC DRAINAGE ITEM DE-WATERING	1 EA		
0071	2542000000-E	846	1'-6" CONCRETE CURB & GUTTER	2,820 LF		
0072	2549000000-E	846	2'-6" CONCRETE CURB & GUTTER	5,200 LF		
0073	2556000000-E	846	SHOULDER BERM GUTTER	183 LF		
0074	2591000000-E	848	4" CONCRETE SIDEWALK	1,440 SY		
0075	2605000000-N	848	CONCRETE CURB RAMPS	14 EA		
0076	2612000000-E	848	6" CONCRETE DRIVEWAY	60 SY		
0077	2647000000-E	852	5" MONOLITHIC CONCRETE ISLANDS (SURFACE MOUNTED)	1,960 SY		
0078	2724000000-E	857	PRECAST REINFORCED CONCRETE BARRIER, SINGLE FACED	166 LF		
0079	2800000000-N	858	ADJUSTMENT OF CATCH BASINS	5 EA		
0080	2815000000-N	858	ADJUSTMENT OF DROP INLETS	1 EA		
0081	2860000000-N	859	CONVERT EXISTING CATCH BASIN TO JUNCTION BOX	1 EA		
0082	2905000000-N	859	CONVERT EXISTING DROP INLET TO JUNCTION BOX	1 EA		
0083	2965000000-N	859	CONVERT EXISTING JUNCTION BOX TO CATCH BASIN	1 EA		
0084	3030000000-E	862	STEEL BEAM GUARDRAIL	2,837.5 LF		
0085	3045000000-E	862	STEEL BEAM GUARDRAIL, SHOP CURVED	387.5 LF		

County: ROCKINGHAM

Line #	Item Number	Sec #	Description	Quantity	Unit Cost	Amount
0086	3150000000-N	862	ADDITIONAL GUARDRAIL POSTS	10 EA		
0087	3210000000-N	862	GUARDRAIL END UNITS, TYPE CAT-1	7 EA		
0088	3215000000-N	862	GUARDRAIL ANCHOR UNITS, TYPE III	3 EA		
0089	3287000000-N	862	GUARDRAIL END UNITS, TYPE TL-3	4 EA		
0090	3288000000-N	862	GUARDRAIL END UNITS, TYPE TL-2	2 EA		
0091	3317000000-N	862	GUARDRAIL ANCHOR UNITS, TYPE B-77	4 EA		
0092	3360000000-E	863	REMOVE EXISTING GUARDRAIL	2,053 LF		
0093	3389150000-N	862	TEMPORARY GUARDRAIL END UNITS, TYPE ***** (TL-3)	2 EA		
0094	3500000000-E	866	WOVEN WIRE FENCE, *** FABRIC (48")	230 LF		
0095	3509000000-E	866	4" TIMBER FENCE POSTS, 7'-6" LONG	6 EA		
0096	3515000000-E	866	5" TIMBER FENCE POSTS, 8'-0" LONG	19 EA		
0097	3533000000-E	866	CHAIN LINK FENCE, *** FABRIC (72")	688 LF		
0098	3539000000-E	866	METAL LINE POSTS FOR *** CHAIN LINK FENCE (72")	59 EA		
0099	3545000000-E	866	METAL TERMINAL POSTS FOR *** CHAIN LINK FENCE (72")	12 EA		
0100	3572000000-E	867	CHAIN LINK FENCE RESET	1,255 LF		
0101	3628000000-E	876	RIP RAP, CLASS I	26 TON		
0102	3635000000-E	876	RIP RAP, CLASS II	105 TON		

County: ROCKINGHAM

Line #	Item Number	Sec #	Description	Quantity	Unit Cost	Amount
0103	3649000000-E	876	RIP RAP, CLASS B	15 TON		
0104	3656000000-E	876	GEOTEXTILE FOR DRAINAGE	985 SY		
0105	4054000000-E	902	PLAIN CONCRETE SIGN FOUNDATIONS	1 CY		
0106	4060000000-E	903	SUPPORTS, BREAKAWAY STEEL BEAM	1,103 LB		
0107	4072000000-E	903	SUPPORTS, 3-LB STEEL U-CHANNEL	631 LF		
0108	4096000000-N	904	SIGN ERECTION, TYPE D	10 EA		
0109	4102000000-N	904	SIGN ERECTION, TYPE E	35 EA		
0110	4108000000-N	904	SIGN ERECTION, TYPE F	10 EA		
0111	4110000000-N	904	SIGN ERECTION, TYPE *** (GROUND MOUNTED) (A)	6 EA		
0112	4138000000-N	907	DISPOSAL OF SUPPORT, STEEL BEAM	6 EA		
0113	4155000000-N	907	DISPOSAL OF SIGN SYSTEM, U- CHANNEL	43 EA		
0114	4238000000-N	907	DISPOSAL OF SIGN, D, E OR F	6 EA		
0115	4360000000-N	SP	GENERIC SIGNING ITEM SUPPORTS, OMNI-DIRECTIONAL BREAKAWAY	4 EA		
0116	4400000000-E	1110	WORK ZONE SIGNS (STATIONARY)	852 SF		
0117	4405000000-E	1110	WORK ZONE SIGNS (PORTABLE)	288 SF		
0118	4410000000-E	1110	WORK ZONE SIGNS (BARRICADE MOUNTED)	118 SF		
0119	4415000000-N	1115	FLASHING ARROW BOARD	2 EA		

County: ROCKINGHAM

Line #	Item Number	Sec #	Description	Quantity	Unit Cost	Amount
0120	4420000000-N	1120	PORTABLE CHANGEABLE MESSAGE SIGN	2 EA		
0121	4422000000-N	1120	PORTABLE CHANGEABLE MESSAGE SIGN (SHORT TERM)	60 DAY		
0122	4430000000-N	1130	DRUMS	275 EA		
0123	4445000000-E	1145	BARRICADES (TYPE III)	144 LF		
0124	4447000000-E	SP	PEDESTRIAN CHANNELIZING DEVICES	72 LF		
0125	4455000000-N	1150	FLAGGER	180 DAY		
0126	4465000000-N	1160	TEMPORARY CRASH CUSHIONS	2 EA		
0127	4480000000-N	1165	TMA	4 EA		
0128	4490000000-E	1170	PORTABLE CONCRETE BARRIER (ANCHORED)	705 LF		
0129	4510000000-N	1190	LAW ENFORCEMENT	720 HR		
0130	4516000000-N	1180	SKINNY DRUM	45 EA		
0131	4600000000-N	SP	GENERIC TRAFFIC CONTROL ITEM AUDIBLE WARNING DEVICES	12 EA		
0132	4650000000-N	1251	TEMPORARY RAISED PAVEMENT MARKERS	13 EA		
0133	4780000000-E	1205	COLD APPLIED PLASTIC PAVEMENT MARKING LINES, TYPE ** (8") (II)	1,318 LF		
0134	4795000000-E	1205	COLD APPLIED PLASTIC PAVEMENT MARKING LINES, TYPE ** (24") (II)	628 LF		
0135	4800000000-N	1205	COLD APPLIED PLASTIC PAVEMENT MARKING CHARACTER, TYPE ** (II)	14 EA		

County: ROCKINGHAM

Line #	Item Number	Sec #	Description	Quantity	Unit Cost	Amount
0136	4805000000-N	1205	COLD APPLIED PLASTIC PAVEMENT MARKING SYMBOL, TYPE ** (II)	66 EA		
0137	4810000000-E	1205	PAINT PAVEMENT MARKING LINES (4")	49,549 LF		
0138	4815000000-E	1205	PAINT PAVEMENT MARKING LINES (6")	3,366 LF		
0139	4820000000-E	1205	PAINT PAVEMENT MARKING LINES (8")	2,760 LF		
0140	4835000000-E	1205	PAINT PAVEMENT MARKING LINES (24")	1,317 LF		
0141	4840000000-N	1205	PAINT PAVEMENT MARKING CHARACTER	16 EA		
0142	4845000000-N	1205	PAINT PAVEMENT MARKING SYMBOL	88 EA		
0143	4846000000-E	1205	POLYUREA PAVEMENT MARKING LINES (***, *** MILS) (4", 30 MILS)	9,203 LF		
0144	4846000000-E	1205	POLYUREA PAVEMENT MARKING LINES (***, *** MILS) (6", 30 MILS)	8,012 LF		
0145	4846000000-E	1205	POLYUREA PAVEMENT MARKING LINES (***, *** MILS) (8", 30 MILS)	1,773 LF		
0146	4850000000-E	1205	REMOVAL OF PAVEMENT MARKING LINES (4")	18,174 LF		
0147	4855000000-E	1205	REMOVAL OF PAVEMENT MARKING LINES (6")	2,054 LF		
0148	4860000000-E	1205	REMOVAL OF PAVEMENT MARKING LINES (8")	435 LF		
0149	4870000000-E	1205	REMOVAL OF PAVEMENT MARKING LINES (24")	461 LF		
0150	4875000000-N	1205	REMOVAL OF PAVEMENT MARKING SYMBOLS & CHARACTERS	31 EA		
0151	4895000000-N	SP	GENERIC PAVEMENT MARKING ITEM POLYCARBONATE H-SHAPED MARKERS	336 EA		

County: ROCKINGHAM

Line #	Item Number	Sec #	Description	Quantity	Unit Cost	Amount
0152	5325000000-E	1510	*** WATER LINE (18")	778 LF		
0153	5325800000-E	1510	8" WATER LINE	40 LF		
0154	5326200000-E	1510	12" WATER LINE	368 LF		
0155	5326600000-E	1510	16" WATER LINE	917 LF		
0156	5329000000-E	1510	DUCTILE IRON WATER PIPE FITTINGS	8,555 LB		
0157	5534000000-E	1515	*** VALVE (18")	2 EA		
0158	5540000000-E	1515	6" VALVE	3 EA		
0159	5546000000-E	1515	8" VALVE	1 EA		
0160	5558000000-E	1515	12" VALVE	3 EA		
0161	5558600000-E	1515	16" VALVE	1 EA		
0162	5562000000-E	1515	*** INSERTION VALVE (16")	1 EA		
0163	5562000000-E	1515	*** INSERTION VALVE (18")	1 EA		
0164	5562000000-E	1515	*** INSERTION VALVE (6")	2 EA		
0165	5571000000-E	1515	*** TAPPING SLEEVE & VALVE (18")	1 EA		
0166	5571600000-E	1515	6" TAPPING SLEEVE & VALVE	2 EA		
0167	5572600000-E	1515	16" TAPPING SLEEVE & VALVE	2 EA		
0168	5589200000-E	1515	2" AIR RELEASE VALVE	2 EA		

County: ROCKINGHAM

Line #	Item Number	Sec #	Description	Quantity	Unit Cost	Amount
0169	5649000000-N	1515	RECONNECT WATER METER	4 EA		
0170	5666000000-N	1515	FIRE HYDRANT	3 EA		
0171	5673000000-E	1515	FIRE HYDRANT LEG	37 LF		
0172	5686500000-E	1515	WATER SERVICE LINE	430 LF		
0173	5709000000-E	1520	*** FORCE MAIN SEWER (10")	1,149 LF		
0174	5709600000-E	1520	12" FORCE MAIN SEWER	605 LF		
0175	5769000000-E	1520	DUCTILE IRON SEWER PIPE FITTINGS	2,415 LB		
0176	5775000000-E	1525	4' DIA UTILITY MANHOLE	2 EA		
0177	5798000000-E	1530	ABANDON *** UTILITY PIPE (18")	1,020 LF		
0178	5800000000-E	1530	ABANDON 6" UTILITY PIPE	1,865 LF		
0179	5801000000-E	1530	ABANDON 8" UTILITY PIPE	100 LF		
0180	5804000000-E	1530	ABANDON 12" UTILITY PIPE	290 LF		
0181	5810000000-E	1530	ABANDON 16" UTILITY PIPE	870 LF		
0182	5815500000-N	1530	REMOVE FIRE HYDRANT	3 EA		
0183	5836000000-E	1540	24" ENCASMENT PIPE	110 LF		
0184	5872500000-E	1550	BORE AND JACK OF *** (24")	110 LF		
0185	5872600000-E	1550	DIRECTIONAL DRILLING OF *** (12")	605 LF		

County: ROCKINGHAM

Line #	Item Number	Sec #	Description	Quantity	Unit Cost	Amount
0186	6000000000-E	1605	TEMPORARY SILT FENCE	11,940 LF		
0187	6006000000-E	1610	STONE FOR EROSION CONTROL, CLASS A	860 TON		
0188	6009000000-E	1610	STONE FOR EROSION CONTROL, CLASS B	2,190 TON		
0189	6012000000-E	1610	SEDIMENT CONTROL STONE	2,050 TON		
0190	6015000000-E	1615	TEMPORARY MULCHING	24 ACR		
0191	6018000000-E	1620	SEED FOR TEMPORARY SEEDING	1,200 LB		
0192	6021000000-E	1620	FERTILIZER FOR TEMPORARY SEEDING	7 TON		
0193	6024000000-E	1622	TEMPORARY SLOPE DRAINS	310 LF		
0194	6029000000-E	SP	SAFETY FENCE	1,520 LF		
0195	6030000000-E	1630	SILT EXCAVATION	4,700 CY		
0196	6036000000-E	1631	MATTING FOR EROSION CONTROL	19,600 SY		
0197	6037000000-E	1629	COIR FIBER MAT	100 SY		
0198	6042000000-E	1632	1/4" HARDWARE CLOTH	5,520 LF		
0199	6043000000-E	1644	LOW PERMEABILITY GEOTEXTILE	1,000 SY		
0200	6045000000-E	SP	*** TEMPORARY PIPE (15")	50 LF		
0201	6071002000-E	1642	FLOCCULANT	1,060 LB		
0202	6071012000-E	1642	COIR FIBER WATTLE	1,120 LF		

County: ROCKINGHAM

Line #	Item Number	Sec #	Description	Quantity	Unit Cost	Amount
0203	6071030000-E	1640	COIR FIBER BAFFLE	215 LF		
0204	6071050000-E	1644	*** SKIMMER (1-1/2")	1 EA		
0205	6084000000-E	1660	SEEDING & MULCHING	21 ACR		
0206	6087000000-E	1660	MOWING	18 ACR		
0207	6090000000-E	1661	SEED FOR REPAIR SEEDING	250 LB		
0208	6093000000-E	1661	FERTILIZER FOR REPAIR SEEDING	1 TON		
0209	6096000000-E	1662	SEED FOR SUPPLEMENTAL SEEDING	475 LB		
0210	6108000000-E	1665	FERTILIZER TOPDRESSING	14.25 TON		
0211	6114500000-N	1667	SPECIALIZED HAND MOWING	10 MHR		
0212	6114800000-N	SP	MANUAL LITTER REMOVAL	10 MHR		
0213	6114900000-E	SP	LITTER DISPOSAL	1 TON		
0214	6117000000-N	1675	RESPONSE FOR EROSION CONTROL	100 EA		
0215	6117500000-N	SP	CONCRETE WASHOUT STRUCTURE	2 EA		
0216	6132000000-N	SP	GENERIC EROSION CONTROL ITEM PREFABRICATED CONCRETE WASHOUT	9 EA		
0217	7048500000-E	1705	PEDESTRIAN SIGNAL HEAD (16", 1 SECTION W/COUNTDOWN)	8 EA		
0218	7060000000-E	1705	SIGNAL CABLE	20,875 LF		
0219	7120000000-E	1705	VEHICLE SIGNAL HEAD (12", 3 SECTION)	91 EA		

County: ROCKINGHAM

Line #	Item Number	Sec #	Description	Quantity	Unit Cost	Amount
0220	7132000000-E	1705	VEHICLE SIGNAL HEAD (12", 4 SECTION)	15 EA		
0221	7144000000-E	1705	VEHICLE SIGNAL HEAD (12", 5 SECTION)	4 EA		
0222	7264000000-E	1710	MESSENGER CABLE (3/8")	4,050 LF		
0223	7288000000-E	1715	PAVED TRENCHING (*****) (1, 2")	25 LF		
0224	7300000000-E	1715	UNPAVED TRENCHING (*****) (1, 2")	2,550 LF		
0225	7300000000-E	1715	UNPAVED TRENCHING (*****) (2, 2")	500 LF		
0226	7324000000-N	1716	JUNCTION BOX (STANDARD SIZE)	57 EA		
0227	7360000000-N	1720	WOOD POLE	19 EA		
0228	7372000000-N	1721	GUY ASSEMBLY	40 EA		
0229	7408000000-E	1722	1" RISER WITH WEATHERHEAD	5 EA		
0230	7420000000-E	1722	2" RISER WITH WEATHERHEAD	10 EA		
0231	7444000000-E	1725	INDUCTIVE LOOP SAWCUT	2,825 LF		
0232	7456100000-E	1726	LEAD-IN CABLE (14-2)	7,650 LF		
0233	7481000000-N	SP	SITE SURVEY	4 EA		
0234	7481200000-N	SP	LUMINAIRE ARM FOR VIDEO SYSTEM	12 EA		
0235	7481240000-N	SP	CAMERA WITHOUT INTERNAL LOOP EMULATOR PROCESSING UNIT	12 EA		
0236	7481260000-N	SP	EXTERNAL LOOP EMULATOR PROCESSING UNIT	4 EA		

County: ROCKINGHAM

Line #	Item Number	Sec #	Description	Quantity	Unit Cost	Amount
0237	7576000000-N	SP	METAL STRAIN SIGNAL POLE	16 EA		
0238	7613000000-N	SP	SOIL TEST	16 EA		
0239	7614100000-E	SP	DRILLED PIER FOUNDATION	96 CY		
0240	7636000000-N	1745	SIGN FOR SIGNALS	24 EA		
0241	7642100000-N	1743	TYPE I POST WITH FOUNDATION	1 EA		
0242	7642200000-N	1743	TYPE II PEDESTAL WITH FOUNDATION	7 EA		
0243	7696000000-N	1751	CONTROLLERS WITH CABINET (***** (2070LX BASE, MOUNTED)	4 EA		
0244	7744000000-N	1751	DETECTOR CARD (TYPE 170)	30 EA		
0245	7901000000-N	1753	CABINET BASE EXTENDER	4 EA		
0246	7980000000-N	SP	GENERIC SIGNAL ITEM MODIFY EXISTING VEHICLE SIGNAL HEAD	2 EA		
WALL ITEMS						
0247	8801000000-E	SP	MSE RETAINING WALL NO **** (1)	3,221 SF		
0248	8801000000-E	SP	MSE RETAINING WALL NO **** (2)	2,915 SF		
STRUCTURE ITEMS						
0249	8035000000-N	402	REMOVAL OF EXISTING STRUCTURE AT STATION ***** (119+69.55 -Y-)	Lump Sum	L.S.	
0250	8065000000-N	SP	ASBESTOS ASSESSMENT	Lump Sum	L.S.	
0251	8096000000-E	450	PILE EXCAVATION IN SOIL	10 LF		

County: ROCKINGHAM

Line #	Item Number	Sec #	Description	Quantity	Unit Cost	Amount
0252	8097000000-E	450	PILE EXCAVATION NOT IN SOIL	190 LF		
0253	8105540000-E	411	3'-6" DIA DRILLED PIERS IN SOIL	8 LF		
0254	8105640000-E	411	3'-6" DIA DRILLED PIERS NOT IN SOIL	60 LF		
0255	8113000000-N	411	SID INSPECTIONS	1 EA		
0256	8115000000-N	411	CSL TESTING	1 EA		
0257	8121000000-N	412	UNCLASSIFIED STRUCTURE EXCAVATION AT STATION ***** (119+69.55 -Y-)	Lump Sum	L.S.	
0258	8147000000-E	420	REINFORCED CONCRETE DECK SLAB	13,421 SF		
0259	8161000000-E	420	GROOVING BRIDGE FLOORS	13,262 SF		
0260	8182000000-E	420	CLASS A CONCRETE (BRIDGE)	239.4 CY		
0261	8210000000-N	422	BRIDGE APPROACH SLABS, STATION ***** (119+69.55 -Y-)	Lump Sum	L.S.	
0262	8217000000-E	425	REINFORCING STEEL (BRIDGE)	41,238 LB		
0263	8238000000-E	425	SPIRAL COLUMN REINFORCING STEEL (BRIDGE)	2,972 LB		
0264	8265000000-E	430	54" PRESTRESSED CONCRETE GIRDERS	1,406 LF		
0265	8328200000-E	450	PILE DRIVING EQUIPMENT SETUP FOR *** STEEL PILES (HP 12 X 53)	20 EA		
0266	8364000000-E	450	HP 12 X 53 STEEL PILES	600 LF		
0267	8391000000-N	450	STEEL PILE POINTS	20 EA		
0268	8394000000-N	450	DYNAMIC PILE TESTING	2 EA		

County: ROCKINGHAM

Line #	Item Number	Sec #	Description	Quantity	Unit Cost	Amount
0269	8475000000-E	460	TWO BAR METAL RAIL	338.48 LF		
0270	8517000000-E	460	1'*** X ***** CONCRETE PARAPET (1'-2" X 3'-3")	355.14 LF		
0271	8531000000-E	462	4" SLOPE PROTECTION	54 SY		
0272	8657000000-N	430	ELASTOMERIC BEARINGS	Lump Sum	L.S.	
0273	8860000000-N	SP	GENERIC STRUCTURE ITEM STRIP SEAL EXPANSION JOINTS	Lump Sum	L.S.	

1014/Dec10/Q466830.528/D1233622374000/E273

Total Amount Of Bid For Entire Project :

8/17/99

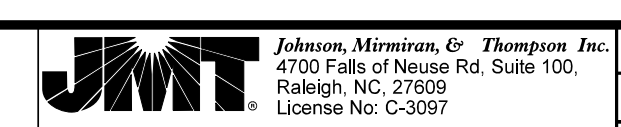

FINAL PAVEMENT SCHEDULE	
C2	PROP. APPROX. 3.0" ASPHALT CONCRETE SURFACE COURSE, TYPE S9.5C, AT AN AVERAGE RATE OF 168 LBS. PER SQ. YD. PER LAYER PLACED IN TWO LAYERS.
D1	PROP. APPROX. 4" ASPHALT CONCRETE INTERMEDIATE COURSE, TYPE I19.0C, AT AN AVERAGE RATE OF 456 LBS. PER SQ. YD.
E1	PROP. APPROX. 4.0" ASPHALT CONCRETE BASE COURSE, TYPE B25.0C, AT AN AVERAGE RATE OF 456 LBS. PER SQ. YD.
J1	PROP. 8" AGGREGATE BASE COURSE
R1	1'-6" CONCRETE CURB AND GUTTER.
R2	2'-6" CONCRETE CURB AND GUTTER.
R3	5" MONOLITHIC CONCRETE ISLAND.
S1	4" CONCRETE SIDEWALK
T	EARTH MATERIAL.
V1	MILLING 3.0"

NOTES:
 1. PAVEMENT EDGE SLOPES ARE 1:1 UNLESS SHOWN OTHERWISE.
 IN AREAS OF NARROW WIDENING, THE 8 INCHES OF AGGREGATE
 2. BASE COURSE MAY BE REPLACED WITH 4" OF B25.0C.

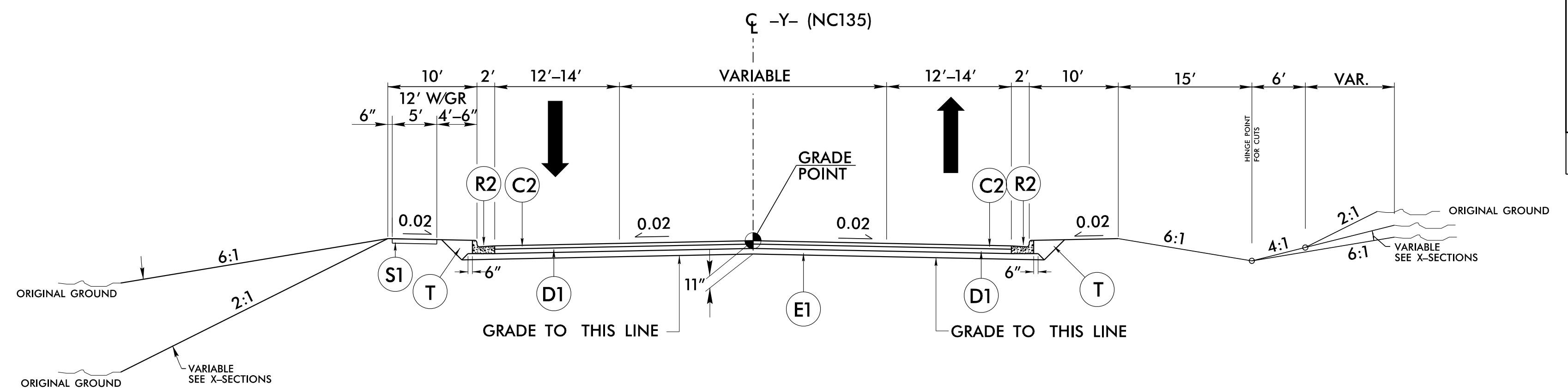

TYPICAL SECTION NO. 2
 -Y- STA. 115+91.09 TO -Y- STA. 118+79.50 (Begin Bridge)
 -Y- STA. 120+59.55 (End Bridge) TO -Y- STA. 122+33.05

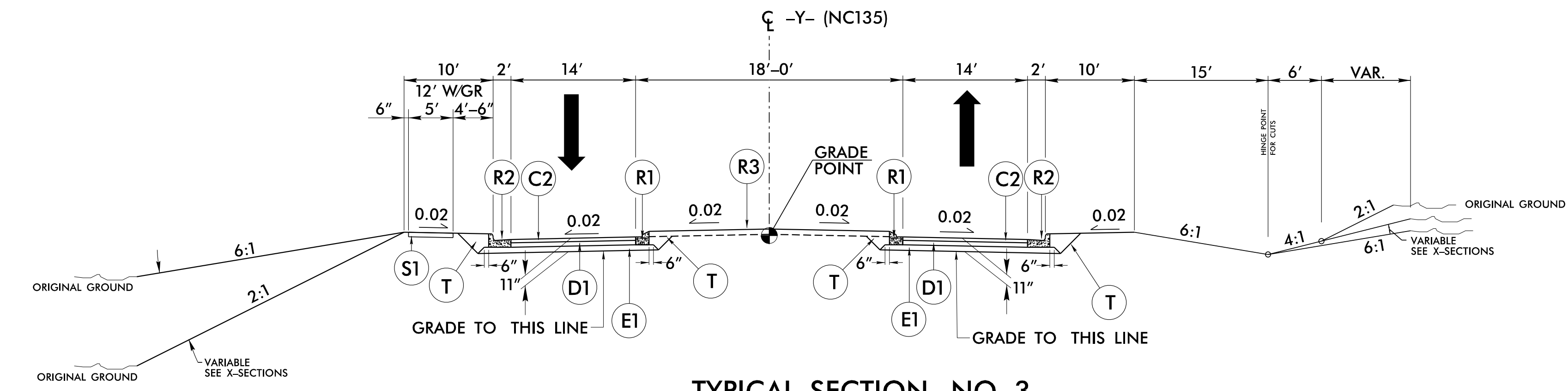

TYPICAL SECTION NO. 3
 -Y- STA. 111+02.20 TO -Y- STA. 115+91.09
 -Y- STA. 122+33.05 TO -Y- STA. 124+50.00

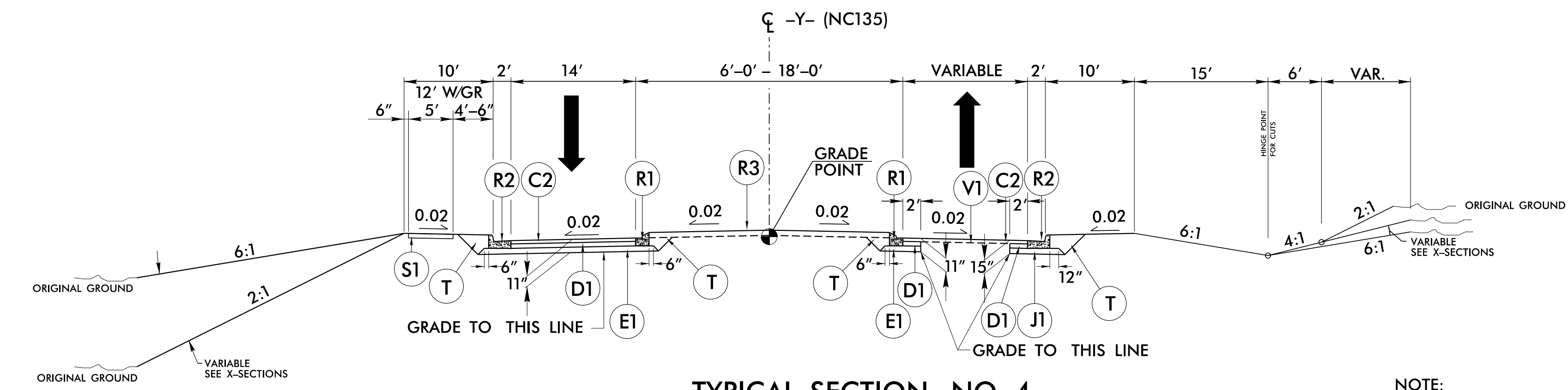

TYPICAL SECTION NO. 4
 -Y- STA. 124+50.00 TO -Y- STA. 130+18.89

NOTE:
 SEE PLANS FOR TURN LANE, TAPERS, TRANSITIONS
 MONOLITHIC ISLANDS AND CURB AND GUTTER

REVISIONS

12/5/2025 9:40:59 AM
 \\nt\00748093\15898.rdj_ttyp.dgn
 User: jmt

5/14/99

PROJECT REFERENCE NO. I-5898	SHEET NO. W-2
<p>DOCUMENT NOT CONSIDERED FINAL UNLESS ALL SIGNATURES COMPLETED</p>	

MSE WALL NO. 1 PROFILE

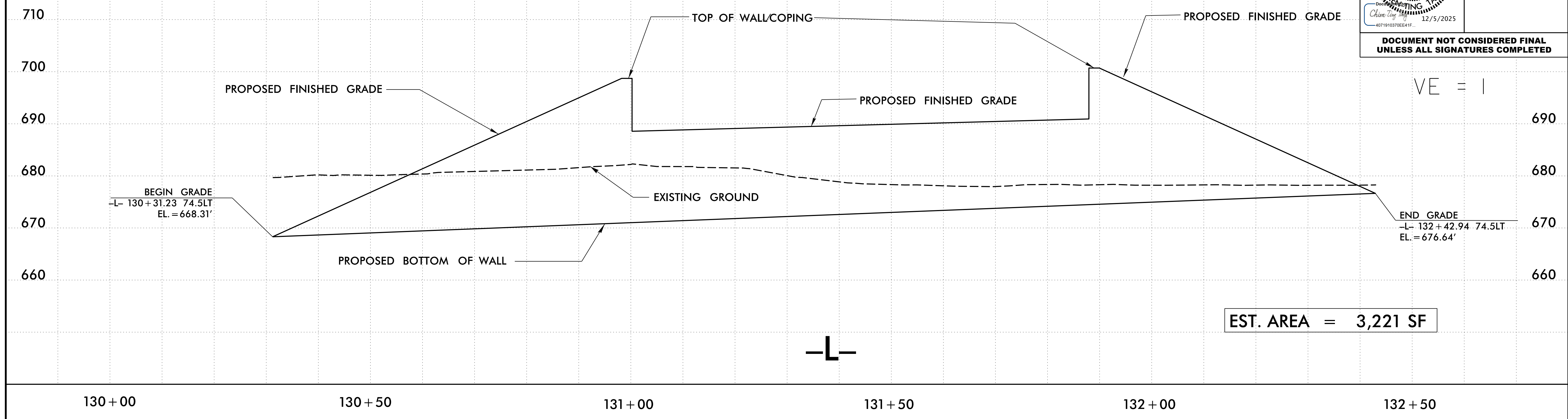

MSE WALL NO. 2 PROFILE

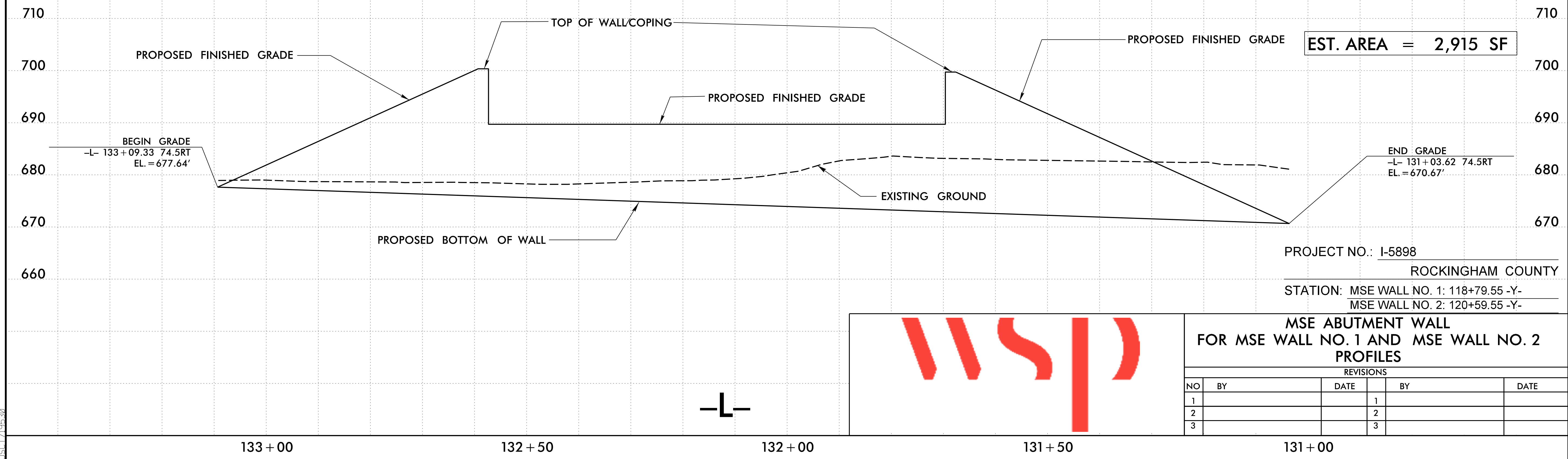

PROJECT NO.: I-5898
 ROCKINGHAM COUNTY
 STATION: MSE WALL NO. 1: 118+79.55 -Y-
 MSE WALL NO. 2: 120+59.55 -Y-



MSE ABUTMENT WALL FOR MSE WALL NO. 1 AND MSE WALL NO. 2 PROFILES					
REVISIONS					
NO	BY	DATE		BY	DATE
1				1	
2				2	
3				3	

I:\12\2025\USCT719530\OneDrive - WSP_0365\00-1\15898 - RE\ise\Retaining Walls\CADD\5898_GEO_MSEW_Sheet2-4.dgn
 12/5/2025 10:57:30 AM
 USCT719530