

-- STATE OF NORTH CAROLINA--
DEPARTMENT OF TRANSPORTATION
RALEIGH, N.C.

EXTERNAL DRAFT RFP

DESIGN-BUILD PROJECT

TIP R-2616

February 27, 2006

VOID FOR BIDDING

DATE AND TIME OF TECHNICAL AND PRICE PROPOSAL SUBMISSION: **June 13, 2006 AT 4:00 PM**

DATE AND TIME OF PRICE PROPOSAL OPENING: **June 29, 2006 AT 10:00 AM**

CONTRACT ID: C 201304

WBS ELEMENT NO. 34485.3.7

F.A. Project. No. STP-601(19)

COUNTY: UNION

ROUTE NO. US 601

MILES: 10.9

LOCATION: US 601 FROM NORTH OF THE SOUTH CAROLINA STATE LINE
TO NORTH OF MARION LEE RD. (SR 2105)

TYPE OF WORK: DESIGN-BUILD AS SPECIFIED IN THE SCOPE OF WORK
CONTAINED IN THE DESIGN-BUILD PACKAGE

NOTICE:

ALL PROPOSERS SHALL COMPLY WITH ALL APPLICABLE LAWS REGULATING THE PRACTICE OF GENERAL CONTRACTING AS CONTAINED IN CHAPTER 87 OF THE GENERAL STATUTES OF NORTH CAROLINA WHICH REQUIRES THE PROPOSER TO BE LICENSED BY THE N.C. LICENSING BOARD FOR CONTRACTORS WHEN BIDDING ON ANY NON-FEDERAL AID PROJECT WHERE THE BID IS \$30,000 OR MORE, EXCEPT FOR CERTAIN SPECIALTY WORK AS DETERMINED BY THE LICENSING BOARD. PROPOSERS SHALL ALSO COMPLY WITH ALL OTHER APPLICABLE LAWS REGULATING THE PRACTICES OF ELECTRICAL, PLUMBING, HEATING AND AIR CONDITIONING AND REFRIGERATION CONTRACTING AS CONTAINED IN CHAPTER 87 OF THE GENERAL STATUTES OF NORTH CAROLINA. NOT WITHSTANDING THESE LIMITATIONS ON BIDDING, THE PROPOSER WHO IS AWARDED ANY PROJECT SHALL COMPLY WITH CHAPTER 87 OF THE GENERAL STATUTES OF NORTH CAROLINA FOR LICENSING REQUIREMENTS WITHIN 60 CALENDAR DAYS OF BID OPENING, REGARDLESS OF FUNDING SOURCES.

5% BID BOND OR BID DEPOSIT REQUIRED

**PROPOSAL FORM FOR THE CONSTRUCTION OF CONTRACT NO. C201304
IN UNION COUNTY, NORTH CAROLINA**

Date _____ 20 _____

**DEPARTMENT OF TRANSPORTATION,
RALEIGH, NORTH CAROLINA**

The Design-Build Team herein acknowledges that it has carefully examined the location of the proposed work to be known as Contract No. C201304; has carefully examined the Final Request for Proposal (RFP) and all addendums thereto, specifications, special provisions, the form of contract, and the forms of contract payment bond and contract performance bonds, which are acknowledged to be part of the Contract; and thoroughly understands the stipulations, requirements and provisions. The undersigned Design-Build Team agrees to be bound upon their execution of the Contract and including any subsequent award to them by the Board of Transportation in accordance with this Contract to provide the necessary contract payment bond and contract performance bond within fourteen calendar days after the written notice of award is received by them.

The undersigned Design-Build Team further agrees to provide all necessary materials, machinery, implements, appliances, tools, labor, and other means of construction, except as otherwise noted, to perform all the work and required labor to design, construct and complete all the work necessary for State Highway Contract No. C201304 in Union County by no later than the dates(s) specified in the Final RFP or Technical Proposal, whichever is earlier, and in accordance with the requirements of the Engineer, the Final RFP, the *2002 Standard Specifications for Roads and Structures*, specifications prepared by the Department, the Technical Proposal prepared by the Design-Build Team, at the lump sum price(s) bid by the Design-Build Team in their Price Proposal.

The Design-Build Team shall provide signed and sealed documents prepared by the Design-Build Team, which specifications and plans show the details covering this project and adhere to the items noted above.

The Design-Build Team acknowledges that project documents furnished by the Department are preliminary and provided solely to assist the Design-Build Team in the development of the project design. Unless otherwise noted herein, the Department does not warrant or guarantee the sufficiency or accuracy of any information furnished by the Department.

The Department does not warrant or guarantee the sufficiency or accuracy of any investigations made, nor the interpretations made or opinions of the Department as to the type of materials and conditions to be encountered at the project site. The Design-Build Team is advised to make such independent investigations, as they deem necessary to satisfy their self as to conditions to be encountered on this project. The Design-Build Team shall have no claim for additional compensation or for an extension of contract time for any reason resulting from the actual conditions encountered at the site differing from those indicated in any of the information or documents furnished by the Department except as may be allowed under the provisions of the Standard Specifications.

Although the Department has furnished preliminary designs for this project, the Design-Build Team shall assume full responsibility, including liability, for the project design, including the use

of portions of the Department design, modification of such design, or other designs as may be submitted by the Design-Build Team.

The Design-Build Team shall be fully and totally responsible for the accuracy and completeness of all work performed under this contract, and shall indemnify and hold the Department harmless for any additional costs and all claims against the Department or the State which may arise due to errors or omissions of the Department in furnishing the preliminary project designs and information, and of the Design-Build Team in performing the work.

The published volume entitled *North Carolina Department of Transportation, Raleigh, Standard Specifications for Roads and Structures, JANUARY 2002*, as well as, all design manuals, policy and procedures manuals, and AASHTO publications and guidelines referenced in the Request For Proposal, with all amendments and supplements thereto, are by reference, incorporated and made part of this contract; that, except as herein modified, all the design, construction and Construction Engineering Inspection included in this contract is to be done in accordance with the documents noted above and under the direction of the Engineer.

If the Design-Build Proposal is accepted and the award is made, the Technical Proposal submitted by the Design-Build Team is by reference, incorporated and made part of this contract. The contract is valid only when signed either by the Contract Officer or such other person as may be designated by the Secretary to sign for the Department of Transportation. The conditions and provisions herein cannot be changed except by written approval as allowed by the Request For Proposal.

Accompanying the Design-Build Proposal shall be a bid bond secured by a corporate surety, or certified check payable to the order of the Department of Transportation, for five percent of the total bid price, which deposit is to be forfeited as liquidated damages in case this bid is accepted and the Design-Build Team shall fail to provide the required payment and performance bonds with the Department of Transportation, under the condition of this proposal, within 14 calendar days after the written notice of award is received by them, as provided in the Standard Specifications; otherwise said deposit will be returned to the Design-Build Team.

TO
BE
SEALED
IN
FINAL
RFP

*State Alternative Delivery
Systems Engineer*

TO
BE
SEALED
IN
FINAL
RFP

State Contract Officer

TABLE OF CONTENTS

COVER SHEET

PROPOSAL SHEETS

PROJECT SPECIAL PROVISIONS (GREEN SHEETS)	PAGE NO.
Contract Time and Liquidated Damages.....	1
Other Liquidated Damages and Incentives.....	1-2
Progress Schedule.....	2-4
Payout Schedule.....	4
Mobilization.....	4
Fuel Price Adjustment.....	4-6
Partnering.....	6
Execution of Signature Sheets and Debarment Certification.....	6-7
Submission of Design-Build Proposals.....	7
Confidential Questions.....	7-8
Value Analysis.....	8
Schedule of Estimated Completion Progress.....	8
Disadvantaged Business Enterprise.....	9-17
Certification for Federal-Aid Projects.....	17
Domestic Steel and Iron Products.....	18
U. S. Department of Transportation Hotline.....	18
Submission of Records – Federal-Aid Projects.....	19
Design Build Team Borrow Source.....	19
Subsurface Information.....	20
Training Requirements.....	20
Safety Vests.....	20
Bid Documentation.....	20-23
Twelve Month Guarantee.....	23
Outsourcing Outside U.S.A.....	23-24
Disqualification of Bidders.....	24
Rejection of Bids.....	24
Erosion and Sedimentation Control Stormwater Certification.....	25-29
Clearing and Grubbing.....	29
Building and Appurtenance Removal/Demolition.....	30
Embankment Monitoring.....	30-31
Price Adjustments for Asphalt Binder.....	31
Price Adjustments Asphalt Concrete Plant Mix.....	31
GENERAL (GREEN SHEETS)	32-43
SCOPES OF WORK (GREEN SHEETS)	
Roadway Design.....	44-47
Structure Design.....	48-49
Pavement Management Design.....	50-54
Hydraulics Design.....	55-56
Geotechnical Engineering.....	57-64
Chemical and Lime Stabilization Scope of Work.....	65-69
Environmental Permits.....	70-73
GeoEnvironmental.....	74-81

Erosion and Sedimentation Control..... 82-85
 Traffic Control..... 86-95
 Signing..... 96-97
 Utilities Coordination..... 98-102
 Right of Way..... 103-104
 Public Information..... 105-106

STANDARD SPECIAL PROVISIONS (YELLOW SHEETS)

Prompt Payment to Subcontractors..... 107
 Borrow and Waste Site Reclamation Procedures..... 107
 Plant and Pest Control Quarantines..... 107-108
 Roadway Excavation..... 108-109
 Borrow Excavation (Excavation of Wetlands)..... 109
 Preparation of Subgrade and Base..... 109
 Asphalt Pavements- Superpave..... 109-122
 Asphalt Binder Content of Asphalt Plant Mixes..... 122
 Final Surface Testing..... 122-126
 Disposal of Waste and Debris..... 126
 Guardrail Posts and Offset Blocks..... 126-128
 Street Signs and Markers and Route Markers..... 128
 Aggregate Production..... 128
 Concrete Brick and Block Production..... 128
 Fine Aggregate..... 129
 Borrow Material..... 129
 Retroreflective Sheeting..... 129-132
 Drums 132
 Portable Concrete Barrier..... 132
 Work Zone Signs..... 133-134
 Barricades..... 134
 Pavement Marking General Requirements..... 134

 Availability of Funds – Termination of Contracts..... 135
 General Seed Specification for Seed Quality 136-138
 Errata..... 139-140
 Award of Contract..... 141
 Minority and Female Employment Requirements..... 142-144
 Required Contract Provisions Federal-Aid Construction Contracts..... 145-153
 Training Special Provisions..... 154-156
 Wage Rates..... 157-160
 Division One 161-242

PROPOSAL FORM ITEM SHEET, ETC.

Item Sheet (WHITE SHEET)
 Fuel Usage Factor Chart (WHITE SHEET)
 Award Limits (YELLOW SHEET)
 DBE Subcontractor Listing (YELLOW SHEETS)
 Signature (YELLOW SHEETS)

***** PROJECT SPECIAL PROVISIONS *****

CONTRACT TIME AND LIQUIDATED DAMAGES (Projects with Permits, NCDOT Acquiring)

The date of availability for this contract is **August 7, 2006** except that work in jurisdictional waters and wetlands shall not begin until a meeting between the DOT, Regulatory Agencies, and the Design-Build Team is held, and the permits acquired as stipulated in the permits contained elsewhere in this proposal. The Design-Build Team shall consider this factor in determining the proposed completion date for this project.

The completion date for this contract is defined as the date proposed in the Technical Proposal by the proposer who is awarded the project. The completion date thus proposed shall not be later than **July 1, 2009**.

The actual completion date proposed by the Design-Build Team is (to be filled in by NCDOT after award).

When observation periods are required by the special provisions, they are not a part of the work to be completed by the completion date and/or intermediate contract times. Should an observation period extend beyond the final completion date, the acceptable completion of the observation period shall be a part of the work covered by the performance and payment bonds.

The liquidated damages for this contract are **Two Thousand Five Hundred Dollars (\$2,500.00)** per calendar day. As an exception to this amount, where the contract has been determined to be substantially complete as defined in Section 105-18 contained elsewhere in this proposal, the liquidated damages will be reduced to **Two Thousand Five Hundred Dollars (\$2,500.00)** per calendar day.

Where the Design-Build Team who is awarded the contract has proposed a completion date for the contract as required above, but also has proposed an earlier date for substantial completion, then both of these proposed dates will become contract requirements.

Liquidated damages of **One Thousand Dollars (\$1,000.00)** per calendar day will be applicable to the early date for substantial completion proposed by the bidder. Liquidated damages of **One Thousand Dollars (\$1,000.00)** per calendar day will be applicable to the final completion date proposed by the bidder where the Design-Build Team has proposed an earlier date for substantial completion.

DB1 G04

OTHER LIQUIDATED DAMAGES AND INCENTIVES (7/13/04)

Traffic Control Liquidated Damages:

Liquidated Damages for lane narrowing, lane closure, holiday and special event time restrictions for US 601 are \$1,000.00 per hour for this Intermediate Contract Time.

Liquidated Damages for road closure time restrictions on US 601, are \$500.00 per 15 minute period or any portion thereof for this Intermediate Contract Time.

Reference the Traffic Control Scope of Work for additional information on the above time restrictions and liquidated damages.

Erosion and Sedimentation Control Incentives:

The Design-Build Team will be eligible for an incentive in the amount of \$100,000 if construction operations have been performed in accordance with all environmental regulations and the Specifications, and the Design-Build Team does not receive any violations (ICA, CICA, NOV and / or C&D) at any time during project construction.

Reference Erosion and Sedimentation Control Scope of Work for additional information.

Liquidated Damages for Erosion Control efforts apply to this project:

The Design-Build Team's first four violations shall result in a reduction of \$25,000 from the \$100,000 incentive noted above for each ICA, CICA, NOV, and / or C&D violation. Beginning with the fifth violation, Liquidated Damages in the amount of \$25,000 per violation shall be deducted from the lump sum bid amount due the Design-Build Team.

Reference the Erosion and Sedimentation Control Scope of Work for additional information and additional Liquidated Damages.

DB1 G11

PROJECT SCHEDULE (8-3-05)**Description**

Perform the work of developing, implementing, monitoring, updating and revising a Project Schedule. Utilize this Project Schedule in coordinating work activities with subcontractors, vendors, suppliers, utilities, railroads, NCDOT, and others, as may be needed, to construct the project.

Design-Build Team's Scheduling Representative

Designate a Design-Build Team authorized representative responsible for developing, updating, and revising the Design-Build Team's Project Schedule. The scheduling representative should attend all schedule related meetings and be capable of providing and presenting information related to the Project Schedule, updates, revisions and related impacts to construction activities, milestones and overall progress.

Project Schedule

The Design-Build Team shall submit a Project Schedule for review within thirty (30) calendar days of receiving the Notice of Award. The Department will review the Project Schedule within twenty-one (21) calendar days of receipt. The Design-Build Team shall make any necessary corrections or adjustments to the Project Schedule as necessitated by the Department's review within seven (7) calendar days. The Department will review the revised Project Schedule within seven (7) calendar days of receipt.

The Department's review of the Project Schedule in no way attests to the validity of the assumptions, constraints, resource allocations, production rates or any other aspect of the Project Schedule. The Design-Build Team is solely responsible for the planning and execution of work in order to meet project milestones and contract completion dates.

The Design-Build Team shall develop a Project Schedule containing the following items:

1. A time scale diagram with milestone dates and, within each milestone, major work activities clearly labeled.
2. A cash curve corresponding to the milestones and work activities established above

Major work activities are defined as components comprising more than five (5) percent of the total project cost or occupying more than ten (10) percent of total contract time and should include, at minimum if applicable, the following:

- Submittals
- Clearing and grubbing
- Drainage installation
- Grading (to include unclassified excavation and borrow excavation)
- Soil stabilization
- Aggregate base course placement
- Utility installation (water and sewer)
- Culvert construction
- Bridge construction (including removal)
- Pavement installation
- Signals, ITS and lighting installation
- Sign installation
- Utility Relocation
- Observation Periods/ Moratoriums/ Seasonal Limitations

Major Milestones are derived from the project construction phasing and should include, at minimum, the following:

- Date of availability
- Start of construction
- Intermediate completion dates or times
- Seasonal limitation durations
- Permit restrictions/conditions
- Traffic shifts
- Detour installation
- Road openings
- Beginning and end of each traffic control phase or work area
- Construction completion date
- Contract completion date

As part of the project schedule package, the Design-Build Team shall provide a written narrative that explains the sequence of work, the controlling operation or operations, intermediate completion dates, milestones, project phasing, anticipated work schedule, and estimated resources. In addition, the Design-Build Team shall explain how permit requirements, environmental requirements, submittal tracking, and coordination with subcontractors, utility companies and other entities will be performed.

The Design-Build Team shall provide a written narrative each month detailing the work and percentage of work completed, anticipated sequence of upcoming work (2 month forecast), controlling operation/s, interim completion dates/times, and milestones. If any milestones are

exceeded or will not be attained, the Design-Build Team shall provide in the written narrative details of the delay; controlling operation affected, impacts to other operations; revisions to future interim completion dates and milestones; and remedial action necessary to get the project back to the original completion date.

Compensation

Payment at the Lump Sum unit price for the contract will be full compensation for all work covered by this section.

DB1 G12

PAYOUT SCHEDULE (1-24-06)

Along with the Price Proposal submittal, the proposer shall include a proposed “Anticipated Monthly Payout Schedule”. The Anticipated Monthly Payout Schedule will be used by the Department, to establish the monthly funding levels for this project. The Anticipated Monthly Payout Schedule shall parallel, and agree with, the project schedule the Design Build Team submits as a part of their Technical Proposal. The schedule shall include a monthly percentage cost breakdown of the work anticipated to be completed. The schedule shall begin with the Date of Availability and end with the Actual Completion Date proposed by the Design Build Team. **If the payout schedule is not included in the Price Proposal package, the Technical and Price Proposals shall be considered irregular by the Department and the bid may be rejected.**

DB1 G13

MOBILIZATION (10-3-05)

Revise the 2002 *Standard Specifications* as follows:

Page 8-1, Subarticle 800-2, COMPENSATION

Delete this subarticle in its entirety and replace with the following:

800-2 COMPENSATION

5 percent of the “Total Amount Bid for Entire Project” shall be considered the lump sum amount for Mobilization. Partial payments for Mobilization will be made beginning with the first partial pay estimate paid on the contract. Payment will be made at the rate of 50 percent of the lump sum amount calculated for Mobilization. The remaining 50 percent will be paid with the partial pay estimate following approval of all permits required in the Environmental Permits Scope of Work for this project.

DB1 G15

FUEL PRICE ADJUSTMENT (10-4-05)

Fuel price adjustments will be made to the payments due the Design-Build Team for specific items of work shown in the Fuel Usage Factor Chart, when the average terminal price has fluctuated from the Base Index Price contained in the contract. The average terminal price is the average of the F.O.B. price for diesel fuel at the terminals in Charlotte, Wilmington and Selma, North Carolina. When the average terminal price fluctuates upward or downward from the Base

Index Price, an amount will be added to or deducted from the monies due the Design-Build Team as follows.

The quantity for the specified items for which payment is being requested will be multiplied by the respective Diesel Fuel Usage Factor contained in the contract to determine the theoretical diesel fuel usage for each specified item. The sum of the theoretical diesel fuel usage for all specified items will be multiplied by the algebraic difference between the average F.O.B. price for diesel fuel at the above specified terminals and the Base Index Price contained in the contract to determine the fuel price adjustment to be made on the partial payment estimate. Fuel Price Adjustments will apply only to Diesel #2 Fuel.

The following formula will be used to calculate the appropriate payment or credit on the estimate.

$$S = (A - B)(\Sigma QF)$$

Where: S = Fuel Price Adjustment for partial payment
 B = Base Index Price
 A = Average terminal price
 Q = Partial payment quantity for contract item
 F = Fuel factor for contract item

The average terminal price in effect on the first day of the month in which the partial payment period ends will be used to make payment adjustments for fuel whether or not more than one price fluctuation has occurred within a single partial payment period.

The fuel price adjustment for the specified item will be determined by multiplying the cumulative fuel price adjustment made for that specified item for the previous estimate period(s) by the adjusted quantity for that specified item and divided by the total quantity of work paid for the previous estimates for the specified item

The Design-Build Team shall prepare, and present with their Price Proposal, an Estimate of Quantities of which they anticipate incorporating into the completed project and upon which the Price Proposal was based. The quantity breakdown shall include all items of work, which appear in the Fuel Usage Factor Chart. This chart is found in the back of this RFP following the Itemized Proposal sheet. The quantity estimate submitted in the Price Proposal is the final total quantity for which fuel price adjustments will be made for each item, regardless of supplemental agreements. The Department shall review the Estimate of Quantities to insure its reasonableness to the proposed design. Agreement of quantities is a prerequisite prior to execution of the contract.

The Design-Build Team's Estimate of Quantities shall be utilized on the various partial payment estimates to determine fuel price adjustments. The Design-Build Team shall submit a payment request for quantities of work completed based on the work completed for that estimate period. The quantities requested for partial payment shall be reflective of the work actually accomplished for the specified period. A licensed Professional Engineer shall sign and seal that

the quantities are reasonable for the specified period. Only those items of work which are specifically noted in the Fuel Usage Factor Chart will be subject to fuel price adjustments.

If the Design-Build Team elects **not** to pursue reimbursement for Fuel Price Adjustments, a quantity of zero should be entered for all quantities in the Fuel Usage Factor Chart (found immediately after the Item Proposal Sheet) and the declination box checked. Failure to complete this form will be taken as declining Fuel Price Adjustments for this project.

The base index price for DIESEL #2 FUEL is \$ INCLUDED IN FINAL RFP per gallon.

DB1 G43

PARTNERING

As a part of its quality management program, the North Carolina Department of Transportation intends to encourage the formation of a cohesive relationship with the Design-Build Team and its principal subcontractors and suppliers. This relationship will be structured to draw on the strengths of each organization to identify and achieve reciprocal goals. The objectives are safe, effective, and efficient contract performance; and completion within budget, on schedule, and in accordance with the plans and specifications.

This relationship will be bilateral in makeup and participation will be totally voluntary. The cost associated with effectuating this relationship will be agreed to by both parties and shall be shared equally.

To implement this initiative prior to starting work in accordance with the requirements of Section 108 of the Standard Special Provisions, Division 1 (found elsewhere in this proposal), and prior to the preconstruction conference, the Design-Build Team's management personnel and Division Construction Engineer will initiate a partnering development seminar/team building workshop. Project personnel working with the assistance of the Construction Unit will make arrangements to determine attendees at the workshop, agenda of the workshop, duration, and location. Persons required to be in attendance will be the NCDOT Resident Engineer, the NCDOT Division Construction Engineer, and key project personnel; the Design-Build Team's senior management personnel, the Design-Build Team's on-site project manager, and key project supervisory personnel for both the Design-Build Team and principal subcontractors and suppliers. The project design engineers, FHWA, and key local government personnel will also be invited to attend as necessary.

Follow-up workshops may be held periodically throughout the duration of the contract as agreed by the Design-Build Team and the North Carolina Department of Transportation.

The establishment of the partnering charter on a project will not change the legal relationship to the contract nor relieve either party from any of the terms of the contract.

DB1 G49

EXECUTION OF SIGNATURE SHEETS AND DEBARMENT CERTIFICATION (9-7-05)

The Proposer's attention is directed to the various sheets in the Request For Proposals which are to be signed by the Proposer. A list of these sheets is shown below. The signature sheets are located behind the item sheet(s) in the Request For Proposals. The NCDOT bid bond form is

available on-line at: <http://ncdot.org/doh/forms/files/bidbond.pdf> or by contacting the Records and Documents office at 919-250-4124.

1. Applicable Signature Sheets: 1, 2, 3, 4, 5, or 6 (Bid)
2. Bid Bond

The Proposer shall certify to the best of his knowledge all subcontractors, material suppliers and vendors utilized herein current status concerning suspension, debarment, voluntary exclusion, or determination of ineligibility by any federal agency, in accordance with the "Debarment Certification" located behind the signature sheets in the proposal forms. Execution of the bid signature sheets in conjunction with any applicable statements concerning exceptions, when such statements have been made on the "Debarment Certification", constitutes the Proposer's certification of "status" under penalty of perjury under the laws of the United States.

DB1 G52

SUBMISSION OF DESIGN BUILD PROPOSAL (Federally Funded Projects)

The Proposer's attention is directed that each Proposer's Design Build Proposal shall comply with the following requirements in order for that Design Build Proposal to be responsible and considered for award.

1. The Proposer shall be prequalified with the Department prior to submitting a Design Build Proposal.
2. The Proposer shall deliver the Design Build Proposal to the place indicated, and prior to the time indicated in the Request For Proposal.
3. The Design Build Proposal documents shall be signed by an authorized employee of the Proposer.
4. The Design Build Proposal shall be accompanied by Bid surety in the form of a Bid bond or Bid deposit.
5. If Disadvantaged Business Enterprises (DBE) goals are established for this contract, the Proposer shall complete the form Listing of DBE Subcontractors contained elsewhere in this proposal in accordance with the Project Special Provision entitled Disadvantaged Business Enterprises.
6. The Design Build Proposal shall address all the requirements as specified in the Request For Proposal document.

In addition to the above requirements, failure to comply with any of the requirements of Articles 102-8, 102-9, 102-10 or 102-11 of the Standard Special Provisions, Division 1 (found elsewhere in this proposal)s may result in a Design Build Proposal being rejected.

DB1 G55

CONFIDENTIAL QUESTIONS (4/5/04)

The Design-Build Team will be permitted to ask confidential questions of the Department, which neither the question nor answer will be shared with other proposing teams. For the purpose of this provision, *confidential question is defined as a private inquiry containing information whose disclosure could alert others to certain details of doing business in a particular manner.*

- I. Confidential questions arising prior to issuance of the final Request for Proposal will be allowed at the draft RFP review with the individual teams.

The Department will answer the confidential question verbally at the meeting if possible. If not answered verbally during the meeting, the Department will answer the confidential question by subtle changes in the Final Request for Proposal, which will clarify the scope by either allowing or disallowing the request. The revision will be made in such a manner as to not disclose the confidential question.

- II. After the issuance of the Final Request for Proposal, confidential questions may be asked by requesting a meeting with the Contract Officer. The request shall be in writing and provide sufficient detail to evaluate the magnitude of the request. Questions shall be of such magnitude as to warrant a special meeting. Minor questions will not be acknowledged or answered.

After evaluation, the Contract Officer will respond to the question in writing to the Design-Build Team only. Other teams will not be notified of the question or answer.

If the Design-Build Team includes work based on the confidential questions and answers, the work shall be included and discussed in the technical proposal. The Technical Proposal will be evaluated in accordance with existing policies.

DB1 G56

VALUE ANALYSIS (9-27-05)

Value Engineering Construction Proposals (VECP), as identified in Article 104-12 of the Standard Special Provisions, Division 1 (found elsewhere in this proposal), will be accepted. Only proposals, which alter the requirements of the RFP issued by the Department, will be considered as Value Engineering Construction Proposals.

DB1 G57

SCHEDULE OF ESTIMATED COMPLETION PROGRESS (9-27-05)

The Design-Build Team's attention is directed to the Standard Special Provision entitled "Availability Of Funds - Termination Of Contracts" included elsewhere in this proposal form. The Department of Transportation's schedule of estimated completion progress for this project as required by that Standard Special Provision is as follows:

<u>Fiscal Year</u>	<u>Progress (Dollar Value)</u>
2007 (7/01/06 – 6/30/07)	43 % of Total Amount Bid
2008 (7/01/07 – 6/30/08)	35 % of Total Amount Bid
2009 (7/01/08 – 6/30/09)	22 % of Total Amount Bid

The Design-Build Team shall also furnish his own progress schedule in accordance with the Project Special Provision entitled PROJECT SCHEDULE (found elsewhere in this proposal). Any acceleration of the progress as shown by the Design-Build Team's progress schedule over the progress as shown above shall be subject to the approval of the Engineer.

DB1 G58

DISADVANTAGED BUSINESS ENTERPRISE (2/24/04)**Policy**

It is the policy of the North Carolina Department of Transportation that Disadvantaged Business Enterprises shall have the opportunity to participate in the performance of contracts financed in whole or in part by Federal Funds in order to create a level playing field.

The Design-Build Team is also encouraged to give every opportunity to allow DBE participation in Supplemental Agreements.

Obligation

The Design-Build Team, subcontractor, and sub-recipient shall not discriminate on the basis of race, color, national origin, or sex in the performance of this contract. The Design-Build Team shall carry out applicable requirements of 49 CFR 26 in the award and administration of federally assisted contracts as approved by the Federal Highway Administration.. Failure by the Design-Build Team to carry out these requirements is a material breach of this contract, which may result in the termination of this contract or such other remedy, as the Department deems necessary.

This obligation shall be incorporated into any subsequent contract at any level that is executed under the terms of this contract.

GOALS

The following goal for participation by Disadvantaged Business Enterprise (DBE) is established for this contract:

Disadvantaged Business Enterprises**10 % of the construction costs**

This goal is to be met through utilization of highway construction contractors. Utilization of DBE firms performing design-related functions or Construction Engineering and Inspection are not included in this goal. DBE utilization for engineering related services is expected and is credited through the technical scoring process.

The Design-Build Team shall exercise all necessary and reasonable steps to ensure that Disadvantaged Business Enterprises participate in at least the percentage of the contract as set forth above as goals for this contract.

Only those firms certified by the Department can be counted toward this contract goal. The Department will provide oversight and direction in carrying forth this program.

Listing Of DBE Subcontractors

All Proposers, at the time the Price Proposal is submitted, must also submit a listing of DBE participation on the appropriate form (or facsimile thereof) contained elsewhere in this proposal in order for the bid to be considered responsive. Proposers must indicate the total dollar value of DBE participation for the contract. In the event the Proposer has no DBE participation, he is still required to indicate this on the forms by entering the word or number zero. Blank forms will not be deemed to represent zero participation. **PROPOSALS SUBMITTED WHICH DO NOT HAVE DBE PARTICIPATION INDICATED ON THE APPROPRIATE FORM WILL**

NOT BE READ PUBLICLY. Those Proposals will not be considered for award by the Department and they will be returned to the Proposer.

Only those DBE firms with current certification by the Department will be considered acceptable for listing in the Proposer submittal of DBE participation.

- A. The Design-Build Team shall indicate on the form for listing of DBE subcontractors contained elsewhere in this proposal the following required information:

REQUIRED INFORMATION

1. The names and addresses of DBE firms committed to participate in the contract
2. The types of work to be performed by each DBE firm; and
3. The total dollar amount to be paid to each DBE based on agreed prices.

Failure to indicate the required information on the specified form will cause the proposal to be considered nonresponsive and it may be rejected.

The Proposer is required to submit written documentation of the proposer/offeror's commitment to use a DBE subcontractor whose participation it submits to meet a contract goal and written confirmation from each DBE, listed in the proposal form, indicating their participation in the contract.

The Department will not allow any substitutions, deletions, or other alterations to the listing of firms committed for DBE participation and/or the respective listed contract item numbers after opening of bids. The Department will not allow adjustments to total dollar amount of DBE participation after the opening of bids that would result in the DBE participation being less than the contract goal. The only exceptions to the requirements of this paragraph will be: (1) to allow for replacement of a DBE firm that had been decertified after opening of bids, and (2) to allow alteration of the listed contract item numbers subject to the Proposer submitting sufficient documentation to verify an obvious error in the initial submittal.

- B. If the DBE participation submitted in the proposal by the apparent lowest responsive Proposer in response to Paragraph A does not meet or exceed the DBE contract goal, the apparent lowest responsive Proposer must submit information to satisfy the North Carolina Department of Transportation that sufficient Good Faith efforts have been made to meet the contract goals. One complete set and nine (9) copies of this information must be received in the office of the State Contractual Services Engineer no later than 12:00 noon of the sixth day following opening of proposals. Where the information submitted includes repetitious solicitation letters it will be acceptable to submit a sample representative letter along with a distribution list of the firms being solicited. Documentation of DBE quotations shall be a part of the good faith effort submittal as necessary to demonstrate compliance with the factors listed below which the Department considers in judging good faith efforts. This documentation may include written subcontractor quotations, telephone log notations of verbal quotations, or other types of quotation documentation.

Where the Proposer fails to provide this information by the deadline, the Department may impose one or more of the following sanctions: (1) disqualify the Design-Build Team

and any affiliated companies from further bidding for a period of time of no more than 90 days from the date of disqualification as established in notification by certified mail, (2) disqualify the Design-Build Team and any affiliated companies for award of all contracts for which bids or proposals have been received and opened, (3) disqualify the Design-Build Team from the contract in question. Additionally, the Proposal may be considered non responsive and no stipend may be paid.

The Department will consider the following factors in judging whether or not the Proposer has made adequate good faith effort:

1. Whether the Proposer attended any pre-bid meetings that were scheduled by the Department to inform DBEs of subcontracting opportunities.
2. Whether the Proposer provided solicitations through all reasonable and available means (e.g. advertising in newspapers owned and targeted to the Disadvantaged) at least 10 days prior to bid opening. Whether the Proposer provided written notice to all DBEs listed in the NCDOT DBE directory, within the Divisions and surrounding Divisions where the project is located, that specialize in the areas of work (as noted in the DBE Directory) that the Proposer will be subcontracting.
3. Whether the Proposer followed up initial solicitations of interests by contacting DBEs to determine with certainty whether they were interested. If a reasonable amount of DBEs within the targeted Divisions do not provide an intent to quote or no DBEs specialize in the subcontracted areas, the Proposer must notify DBEs outside of the targeted Divisions that specialize in the subcontracted areas, as well as call the project Compliance Officer in the Office of Civil Rights to give notification of the proposer inability to get DBE quotes.
4. Whether the Proposer selected portions of the work to be performed by DBEs in order to increase the likelihood of meeting the contract goals. This includes, where appropriate, breaking out contract work items into economically feasible units to facilitate DBE participation, even when the Design-Build Team might otherwise perform these work items with its own forces.
5. Whether the Proposer provided interested DBEs with adequate and timely information about the plans, specifications and requirements of the contract
6. Whether the Proposer negotiated in good faith with interested DBEs not rejecting them as unqualified without sound reasons based on a thorough investigation of their capabilities. Any rejection should be so noted in writing with a description as to why an agreement could not be reached.
7. Whether quotations were received from interested DBE firms but rejected as unacceptable without sound reasons why the quotations were considered unacceptable. The fact that the DBE firms quotation for the work is not the lowest quotation received will not in itself be considered as a sound reason for rejecting the quotation as unacceptable. The fact that the Proposer has the ability and/or desire to perform the contract work with its own forces will not be considered as sound reason for rejecting a DBE quote. Nothing in this provision

shall be construed to require the Design-Build Team to accept unreasonable quotes in order to satisfy contract goals.

8. Whether the Proposer specifically negotiated with subcontractors to assume part of the responsibility to meet the contract DBE goal when the work to be sublet includes potential for DBE participation.
9. Whether the Proposer made any efforts and/or offered assistance to interested DBEs in obtaining the necessary equipment, supplies, materials, insurance, and/or bonding to satisfy the work requirements in the bid proposal.
10. Any other evidence that the Proposer submits which show that the Proposer has made reasonable Good Faith efforts to include DBE participation.

In the event one Proposer is the apparent low Proposer on more than one project within the same letting located in the same geographic area of the state, as a part of the good faith effort the Department will consider allowing the Proposer to combine the DBE participation as long as the overall goal value of all projects is achieved.

Where the apparent lowest responsive Proposer fails to submit sufficient participation by DBE firms to meet the contract goal and upon a determination by the Goal Compliance Committee based upon the information submitted that the apparent lowest responsive Proposer failed to make sufficient reasonable efforts to meet the contract goal, the Proposer will be offered the opportunity to meet in person for administrative reconsideration. A committee appointed by the Department will hear administrative reconsideration. Members of this committee will be officials who did not take part in the original determination by the Goal Compliance Committee. The Proposer will have the opportunity to present written documentation or argument concerning the issue of whether it met the goal or made an adequate good faith effort. The Proposer will receive a written decision on the reconsideration. Explaining the basis for finding that the Proposer did or did not meet the goal or made adequate Good Faith efforts to do so. The result of the reconsideration process is not administratively appealable to the Department.

In the event that the Department does not award the contract to the apparent lowest responsive Proposer, the Department reserves the right to award the contract to the next lowest responsive Proposer that can satisfy the Department that the contract goal can be met or that adequate good faith efforts have been made to meet the goal.

DBE Directory

Included with this Request For Proposals is a list of Disadvantaged Business Enterprises (DBE) which have been certified as such by the North Carolina Department of Transportation. Only those DBE firms with current certification may be listed in the proposal form.

The listing of an individual firm in the Department's directory shall not be construed as an endorsement of the firms' capability to perform certain work.

Replacement OF DBEs

A. Performance Related

If any DBE Subcontractor submitted on the form for listing of DBE Subcontractors, contained elsewhere in this proposal form, is terminated or fails to complete its work on the contract for any reason, the Design-Build Team shall take all necessary, reasonable steps to replace the DBE Subcontractor with another DBE Subcontractor to perform at least the same amount of work of the contract as the DBE that was terminated.

To demonstrate necessary, reasonable Good Faith efforts, the Design-Build Team shall document the steps he has taken to replace any DBE Subcontractor who is unable to perform successfully with another DBE Subcontractor. Such documentation shall include but not be limited to the following:

1. Copies of written notification to DBEs that their interest is solicited in subcontracting the work defaulted by the previous DBE subcontractor or in subcontracting other items of work in the contract.
2. Efforts to negotiate with DBEs for specific subbids including, at a minimum:
 - a. The names, addresses, and telephone numbers of DBEs who were contacted;
 - b. A description of the information provided to DBEs regarding the plans and specifications for portions of the work to be performed; and
3. For each DBE contacted but rejected as unqualified, the reasons for the Design-Build Team's conclusion.
4. Efforts made to assist the DBEs contacted, if needed, in obtaining bonding or insurance required by the Design-Build Team.

The Design-Build Team will not terminate a DBE subcontractor listed in the proposal form for convenience or perform the work with its own forces or those of an affiliate without the written approval of the Engineer. If the Design-Build Team fails to demonstrate reasonable efforts to replace a DBE firm that does not perform as intended or completes the work with its own forces without the Engineer's approval, the Design-Build Team will be disqualified from further bidding for a period of up to 6 months after notification by certified mail.

B. Decertification

1. If a Design-Build Team has listed a DBE firm in his proposal and that DBE Subcontractor is subsequently decertified by the Department after a Request for Subcontract has been approved, then the Department will not require the Design-Build Team to solicit replacement DBE participation equal to the remaining work to be performed by the decertified firm. The participation equal to the remaining work performed by the decertified firm will count toward the contract goal but may not be counted toward the overall program goal.
2. If a Design-Build Team has listed a DBE firm in his proposal and the DBE firm is decertified prior to the Department approving a Request for Subcontract for the named DBE firm, the Design-Build Team shall take all necessary and reasonable

steps to replace the DBE subcontractor with another DBE subcontractor to perform at least the same amount of work to meet the contract goal or demonstrate that it has made a Good Faith effort to do so.

Definitions

For purposes of this provision the following definitions will apply:

- A. Socially and economically disadvantaged individuals means a person who has a net worth of \$750,000.00 or less and is a citizen or lawful permanent resident of the United States and who is:
 - 1. A Black American
 - 2. A Hispanic American
 - 3. A Subcontinent Asian American
 - 4. A Native American
 - 5. An Asian-Pacific American
 - 6. A Woman
 - 7. Members of other groups, or other individuals found to be economically and socially disadvantaged by the Small Business Administration under Section 8(d) of the Small Business Act, as amended (15 U.S.C. 637(d)).
 - 8. Members of other groups, or other individuals found to be economically and socially disadvantaged by the N. C. Department of Transportation under the Criteria for Disadvantaged Business Enterprises as published by the Department.

- B. Disadvantaged Business Enterprise (DBE) means a for-profit small business concern.
 - 1. That is at least 51 percent owned by one or more individuals who are both socially and economically disadvantaged or, in the case of a corporation in which 51 percent of the stock is owned by one or more such individuals; and
 - 2. Whose management and daily business operation are controlled by one or more of the socially and economically disadvantaged individuals who own it,

Counting DBE Participation Toward Meeting The DBE Goal

- A. If a firm is determined to be an eligible DBE firm and certified by the Department, the total dollar value of the participation by the DBE will be counted toward the goal. The total dollar value of participation by a certified DBE will be based upon the value of work actually performed by the DBE and the actual payments to DBE firms by the Design-Build Team.

- B. When a DBE performs as a participant in a joint venture, the Design-Build Team may count toward its DBE goal a portion of the total value of participation with the DBE in the joint venture, that portion of the total dollar value being a distinct clearly defined portion of work that the DBE performs with its forces.

- C. 1. The Design-Build Team may count toward its DBE goal only expenditures to DBEs that perform a commercially useful function in the work of a contract. A DBE is considered to perform a commercially useful function when it is responsible for execution of a distinct element of the work of a contract and carrying out its responsibilities by actually performing, managing, and supervising the work involved. To determine whether a DBE is performing a commercially useful function, the Department will evaluate the amount of work subcontracted, industry practices, whether the amount the firm is to be paid under the contract is commensurate with the work it is actually performing and the DBE credit claimed for its performance of the work, and other relevant factors.
2. Consistent with normal industry practices, a DBE may enter into subcontracts. Work that a DBE subcontracts to another DBE firm may be counted toward the contract goal. Work that a DBE subcontracts to a non-DBE firm does not count toward the contract goal. If a DBE Design-Build Team or Subcontractor subcontracts a significantly greater portion of the work of the contract than would be expected on the basis of normal industry practices, the DBE shall be presumed not to be performing a commercially useful function. The Department's decision on the rebuttal of this presumption is subject to review by the Federal Highway Administration but is not administratively appealable to USDOT.
3. The following factors will be used to determine if a DBE trucking firm is performing a commercially useful function.
- a. The DBE firm must be responsible for the management and supervision of entire trucking operation
 - b. The DBE must itself own and operate at least one fully licensed, insured and operational truck
 - c. The DBE will receive full credit for all trucks it owns, insures, operates, and employs drivers
 - d. The DBE will receive full credit for all trucks leased from a certified DBE firm
 - e. The DBE will only receive credit for the fees or commission for trucks leased from a non-DBE firm
 - f. Others may use trucks during the term of the lease so long as the lease gives priority to the DBE for the use of the truck(s).

The DBE may present evidence to rebut this presumption to the Department for commercially useful functions.

- D. A Design-Build Team may count toward its DBE goal 60 percent of its expenditures for materials and supplies required to complete the contract and obtained from DBE regular dealer and 100 percent of such expenditures to a DBE manufacturer.
1. For purposes of this provision, a manufacturer is a firm that operates or maintains a factory or establishment that produces on the premises the materials or supplies obtained by the Design-Build Team.
 2. For purposes of this provision, a regular dealer is a firm that owns, operates, or maintains a store, warehouse, or other establishment in which the materials or

supplies required for the performance of the contract are bought, kept in stock, and regularly sold to the public in the usual course of business. To be a regular dealer, the firm must engage in, as its principal business and in its own name, the purchase and sale of the products in question. A regular dealer in such bulk items as steel, cement, gravel, stone, and petroleum products need not keep such products in stock, if it owns or operates distribution equipment. Brokers and packagers shall not be regarded as manufacturers or regular dealers within the meaning of this section.

- E. A Design-Build Team may count toward its DBE goal the following expenditures to DBE firms that are not manufacturers or regular dealers:
1. The fees or commissions charged by a DBE firm for providing a bona fide service, such as professional, technical, consultant, or managerial services, or for providing bonds or insurance specifically required for the performance of a DOT-assisted contract, toward DBE goal, provided the fees or commissions are determined to be reasonable and not excessive as compared with fees and commissions customarily allowed for similar services.
 2. The fees or commissions charged for assistance in the procurement of the materials and supplies, or for transportation charges for the delivery of materials or supplies required on a job site (but not the cost of the materials and supplies themselves), toward DBE goals, provided the fees are not from a manufacturer or regular dealer and provided the fees are determined to be reasonable and not excessive as compared with fees customarily allowed for similar services.

Reports

All requests for subcontracts involving DBE subcontractors shall be accompanied by a certification executed by both the Design-Build Team and the DBE subcontractor attesting to the agreed upon unit prices and extensions for the affected contract items. This document shall be on the Department's Form RS-1-D, or in lieu of using the Department's Form, copies of the actual executed agreement between the Design-Build Team and the DBE subcontractor may be submitted. In any event, the Department reserves the right to require copies of actual subcontract agreements involving DBE Subcontractors.

The RS-1-D certification forms may be obtained from the Department's Resident Engineer.

These certifications shall be considered a part of the project records, and consequently will be subject to penalties under Federal Law associated with falsifications of records related to projects.

Reporting Disadvantaged Business Enterprise Participation

When payments are made to Disadvantaged Business Enterprise firms, including material suppliers, contractors at all levels (prime, subcontractor, or second tier subcontractor) shall provide the Engineer with an accounting of said payments. This accounting shall be furnished to the Engineer for any given month by the end of the following month. Failure to submit this information accordingly may result in (1) withholding of money due in the next partial pay estimate; or (2) removal of an approved Design-Build Team from the prequalified Proposer's list

or the removal of other entities from the approved subcontractors list. The accounting shall list for each payment made to a Disadvantaged Business Enterprise firm the following:

- DOT Project Number
- Payee Design-Build Team Name
- Receiving Design-Build Team or Material Supplier
- DBE Certification Basis, e.g., Woman Owned, Native American, African American, etc.
- Amount of Payment
- Date of Payment

A responsible fiscal officer of the payee Design-Build Team, subcontractor, or second tier subcontractor who can attest to the date and amounts of the payments shall certify that the accounting is correct. A copy of an acceptable report may be obtained from the Engineer.

DB1 G61

CERTIFICATION FOR FEDERAL-AID CONTRACTS

The prospective participant certifies, by signing and submitting this bid or proposal, to the best of his or her knowledge and belief, that:

- (1) No Federal appropriated funds have been paid or will be paid, by or on behalf of the undersigned, to any person for influencing or attempting to influence an officer or employee of any Federal agency, a Member of Congress, an officer or employee of Congress, or an employee of a Member of Congress in connection with the awarding of any Federal contract, the making of any Federal grant, the making of any Federal loan, the entering into of any cooperative agreement, and the extension, continuation, renewal, amendment, or modification of any Federal contract, grant, loan, or cooperative agreement.
- (2) If any funds other than Federal appropriated funds have been paid or will be paid to any person for influencing or attempting to influence an officer or employee of any Federal agency, a Member of Congress, an officer or employee of Congress, or an employee of a Member of Congress in connection with this Federal contract, grant, loan, or cooperative agreement, the undersigned shall complete and submit Standard Form-LLL, "Disclosure Form to Report Lobbying," in accordance with its instructions.

This certification is a material representation of fact upon which reliance was placed when this transaction was made or entered into. Submission of this certification is a prerequisite for making or entering into this transaction imposed by Section 1352, *Title 31, U.S. Code*. Any person who fails to file the required certification shall be subject to a civil penalty of not less than \$10,000 and not more than \$100,000 for each such failure.

The prospective participant also agrees by submitting his or her bid or proposal that he or she shall require that the language of this certification be included in all lower tier subcontracts, which exceed \$100,000 and that all such sub-recipients shall certify and disclose accordingly.

DB1 G85

DOMESTIC STEEL AND IRON PRODUCTS (7-1-95)

All steel and iron products which are permanently incorporated into this project shall be produced in the United States except minimal amounts of foreign steel and iron products may be used provided the combined project cost of the bid items involved does not exceed one-tenth of one percent (0.1 percent) of the total amount bid for the entire project or \$2,500.00, whichever is greater. This minimal amount of foreign produced steel and iron products permitted for use by this Special Provision is not applicable to fasteners. Domestically produced fasteners are required for this project.

All steel and iron products furnished as "domestic products" shall be melted, cast, formed, shaped, drawn, extruded, forged, fabricated, produced, or otherwise processed and manufactured in the United States. Raw materials including pig iron and processed pelletized and reduced iron ore used in manufacturing "domestic" steel products may be imported; however, all manufacturing processes to produce the products, including coatings, must occur in the United States.

Before each steel or iron product is incorporated into this project or included for partial payment on a monthly estimate, the Design-Build Team shall furnish the Resident Engineer a notarized certification certifying that the product conforms to the above requirements of this Special Provision. The Resident Engineer will forward a copy of each certification to the Materials and Tests Unit.

Each purchase order issued by the Design-Build Team or a subcontractor for steel and iron products to be permanently incorporated into this project shall contain in bold print a statement advising the supplier that all manufacturing processes to produce the steel or iron shall have occurred in the United States. The Design-Build Team and all affected subcontractors shall maintain a separate file for steel products permanently incorporated into this project so that verification of the Design-Build Team's efforts to purchase "domestic" steel and iron products can readily be verified by an authorized representative of the Department or the Federal Highway Administration.

DB1 G97

U.S. DEPARTMENT OF TRANSPORTATION HOTLINE (11-22-94)

To report bid rigging activities call: **1-800-424-9071**

The U.S. Department of Transportation (DOT) operates the above toll-free "hotline" Monday through Friday, 8:00 a.m. to 5:00 p.m. eastern time. Anyone with knowledge of possible bid rigging, bidder collusion, or other fraudulent activities should use the "hotline" to report such activities.

The "hotline" is part of the DOT's continuing effort to identify and investigate highway construction contract fraud and abuse is operated under the direction of the DOT Inspector General. All information will be treated confidentially and caller anonymity will be respected.

DB1 G100

SUBMISSION OF RECORDS - FEDERAL-AID PROJECTS (12-15-98)

The Design-Build Team's attention is directed to the Standard Special Provisions entitled "Required Contract Provisions - Federal-Aid Construction Contracts" contained elsewhere in this Request For Proposals.

This project is located on the National Highway System. If the final construction cost of this project equals or exceeds **One Million Dollars**, the Design-Build Team must submit federal form FHWA-47.

DB1 G106

DESIGN-BUILD TEAM BORROW SOURCE (12-1-05)

Revise the *2002 Standard Specifications* as follows:

Page 2-17, Article 230-4(C) Design-Build Team Furnished Sources, add the following:

If the Design-Build Team proposes a borrow source, the environmental assessment shall include wetland and stream delineation extending 400 feet beyond the proposed borrow source limits.

1. If wetlands or streams are present within 400 feet of the borrow source:
 - Submit a hydrologic analysis (Skaggs Method) or equivalent to determine if lateral effects will permanently impact or cause degradation to wetlands or streams. The analysis shall be performed by an environmental or hydraulics engineer with expertise in this discipline and shall consist of, but not be limited to:
 - Hydric soil type
 - Average profile depth to restrictive soil layer
 - Effective hydraulic conductivity or permeability
 - Average drainable porosity or available water capacity
 - Required buffer width, including safety factor
2. If wetlands or streams are present within 400 feet and the Design-Build Team does not propose to excavate below the seasonal high water table or the water level in the adjacent stream, no documentation will be required.
3. If wetlands or streams are not present within 400 feet, no additional documentation will be required

During Department review of the proposed borrow area, the hydrologic analysis will be submitted to the U. S. Army Corps of Engineers for evaluation.

Obtain copy of Skaggs Method for Determining Lateral Effects of a Borrow Pit on Adjacent Wetlands, revised 12/1/05, from Roadside Environmental Unit web site:

http://www.ncdot.org/doh/operations/dp_chief_eng/roadside/fieldops/

Copies may also be obtained from Room 558, Transportation Building, 1 S. Wilmington Street, Raleigh, NC 27601.

DB1 G111

SUBSURFACE INFORMATION (9-27-05)

Available subsurface information will be provided on this project. The Design-Build Team will be responsible for additional investigations.

DB1 G119

TRAINING REQUIREMENTS (7-1-95)

The Design-Build Team's attention is directed to the Standard Special Provision "Training Special Provision" included elsewhere in this Request For Proposal.

The number of trainees to be trained on this project shall be **FIVE (5)**.

DB1 G136

SAFETY VESTS (11/9/04)

All the Design-Build Team's personnel, all subcontractors and their personnel, and any material suppliers and their personnel, shall wear a reflective vest or outer garment conforming to the requirements of MUTCD at all times while on the project.

DB1 G139

BID DOCUMENTATION (5/6/04)**General**

The successful Proposer (Design-Build Team) shall submit the original, unaltered bid documentation or a certified copy of the original, unaltered bid documentation used to prepare the Price Proposal for this contract to the Department. Such documentation shall be placed in escrow with a banking institution or other bonded document storage facility selected by the Department and preserved by that institution or facility as specified in the following sections of this provision.

Bid Documentation

The terms "bid documentation" as used in this provision means all written information, working papers, computer printouts and diskettes, charts, and all other data compilations which contain or reflect information, data, and calculations used by the Proposer in the preparation of their Price Proposal. The term "bid documentation" includes, but is not limited to, Design-Build Team equipment rates, Design-Build Team overhead rates, labor rates, efficiency or productivity factors, arithmetical calculations, and quotations from subcontractors and material suppliers to the extent that such rates and quotations were used by the Proposer in formulating and determining the bid. The term "bid documentation" also includes any manuals, which are standard to the industry used by the Proposer in determining the bid. Such manuals may be included in the bid documentation by reference. Such reference shall include the name and date of the publication and the publisher. The term does not include bid documents provided by the Department for use by the Proposer in bidding on this project.

Submittal Of Bid Documentation

A representative of the Proposer shall deliver the original, unaltered bid documentation or a certified copy of the original, unaltered bid documentation to the Department, in a container suitable for sealing, within ten (10) days after the notice of award is received by him. Bid

documentation will be considered a certified copy if the Proposer includes a letter to the Department from a chief officer of the company stating that the enclosed documentation is an EXACT copy of the original documentation. The letter must be signed by a chief officer of the company, have the person's name and title typed below the signature, and the signature MUST be notarized at the bottom of the letter. The Department will not execute the contract until the original, unaltered bid documentation or a certified copy of the original, unaltered bid documentation has been received by the Department. The container shall be clearly marked "Bid Documentation" and shall also show on the face of the container the Proposer's name, Proposer's address, the date of submittal, the Project Number, and the County.

Affidavit

In addition to the bid documentation, an affidavit signed under oath by an individual authorized by the Proposer to execute the bid shall be included. The affidavit shall list each bid document with sufficient specificity so a comparison may be made between the list and the bid documentation to ensure that all of the bid documentation listed in the affidavit has been enclosed. The affidavit shall attest that the affiant has personally examined the bid documentation, that the affidavit lists all of the documents used by the Proposer to determine the bid for this project, and that all such bid documentation has been included.

Verification

Upon delivery of the bid documentation, the Department's Contract Officer and the Proposer's representative will verify the accuracy and completeness of the bid documentation compared to the affidavit. Should a discrepancy exist, the Proposer's representative shall immediately furnish the Department's Contract Officer with any other needed bid documentation. The Department's Contract Officer upon determining that the bid documentation is complete will, in the presence of the Proposer's representative, immediately place the complete bid documentation and affidavit in the container and seal it. Both parties will deliver the sealed container to a banking institution or other bonded document storage facility selected by the Department for placement in a safety deposit box, vault, or other secure accommodation.

Duration And Use

The bid documentation and affidavit shall remain in escrow until sixty (60) calendar days from the time the Design-Build Team receives the final estimate; or until such time as the Design-Build Team gives written notice of intent to file a claim, files a written claim, files a written and verified claim, or initiates litigation against the Department related to the contract; or until authorized in writing by the Design-Build Team. Upon the giving of written notice of intent to file a claim, filing a written claim, filing a written and verified claim, or the initiation of litigation by the Design-Build Team against the Department, or receipt of a letter from the Design-Build Team authorizing release, the Department may obtain the release and custody of the bid documentation. If the bid documentation remains in escrow sixty (60) calendar days after the time the Design-Build Team receives the final estimate and the Design-Build Team has not filed a written claim, filed a written and verified claim, or has not initiated litigation against the Department related to the contract, the Department shall instruct the banking institution or other bonded document storage facility to release the sealed container to the Design-Build Team.

The Proposer certifies and agrees that the sealed container placed in escrow contains all of the bid documentation used to determine the bid and that no other bid documentation shall be

relevant or material in litigation over claims brought by the Design-Build Team arising out of this contract.

Failure To Provide Bid Documentation

The Proposer's failure to provide the original, unaltered bid documentation or a certified copy of the original, unaltered bid documentation within ten (10) days after the notice of award is received by him may be just cause for rescinding the award of the contract and may result in the removal of the Proposer from the Department's list of qualified Proposers for a period up to 180 days. Award may then be made to the next lowest responsible Proposer or the work may be readvertised and constructed under the contract or otherwise, as the Board of Transportation may decide.

Escrow Agreement

The Proposer will be required to sign an Escrow Agreement within ten (10) days after the notice of award is received by him. A copy of this Escrow Agreement document will be mailed to the Proposer with the notice of award for informational purposes. The Proposer and Department will sign the Escrow Agreement at the time that the bid documentation is delivered to a Banking Institution or other facility as outlined above. The Proposer's failure to sign the Escrow Agreement at the time the bid documentation is delivered may be just cause for rescinding the award of the contract and may result in the removal of the Proposer from the Department's list of qualified Proposers for a period up to 180 days. Award may then be made to the next lowest responsible Proposer or the work may be readvertised and constructed under the contract or otherwise, as the Board of Transportation may decide.

Confidentiality Of Bid Documentation

The bid documentation and affidavit in escrow are, and will remain, the property of the Proposer. The Department has no interest in, or right to, the bid documentation and affidavit other than to verify the contents and legibility of the bid documentation unless the Design-Build Team gives written notice of intent to file a claim, files a written claim, files a written and verified claim, or initiates litigation against the Department. In the event of such written notice of intent to file a claim, filing of a written claim, filing a written and verified claim, or initiation of litigation against the Department, or receipt of a letter from the Design-Build Team authorizing release, the bid documentation and affidavit may become the property of the Department for use in considering any claim or in litigation as the Department may deem appropriate.

Any portion or portions of the bid documentation designated by the Proposer as a "trade secret" at the time the bid documentation is delivered to the Department's Contract Officer shall be protected from disclosure as provided by *General Statutes 132-1.2*.

Cost And Escrow Instructions

The cost of the escrow will be borne by the Department. The Department will provide escrow instructions to the banking institution or other bonded document storage facility consistent with this provision.

Payment

There will be no separate payment for all costs of compilation of the data, container, or verification of the bid documentation. Payment at the lump sum price for the Design-Build project will be full compensation for all such costs.

DB1 G142

TWELVE-MONTH GUARANTEE (9-27-05)

- A. The Design-Build Team shall guarantee materials and workmanship against latent and patent defects arising from faulty materials, faulty workmanship or negligence for a period of twelve months following the date of final acceptance of the work for maintenance and shall replace such defective materials and workmanship without cost to the Department.
- B. Where items of equipment or material carry a manufacturer's guarantee for any period in excess of twelve months, then the manufacturer's guarantee shall apply for that particular piece of equipment or material. The Department's first remedy shall be through the manufacturer although the Design-Build Team is responsible for invoking the warranted repair work with the manufacturer. The Design-Build Team's responsibility shall be limited to the term of the manufacturer's guarantee.
- C. The Design-Build Team shall be responsible for any and all remediation activities at the on-site stream and wetland mitigation sites for a period of twelve months following final acceptance of the project at no additional cost to the Department.

This guarantee provision shall be invoked only for major components of work for which the Design-Build Team would be wholly responsible under the terms of the contract. Examples would include pavement structures, bridge components, noise walls, and sign structures. This provision shall not be used as a mechanism to force the Design-Build Team to return to the project to make repairs or perform additional work for which the Department would normally compensate the Design-Build Team. In addition, routine maintenance activities (i.e. mowing grass, debris removal, ruts in earth shoulders,) are not parts of this guarantee.

Appropriate provisions of the payment and/or performance bonds shall cover this guarantee for the project. In addition, failure on the part of the responsible entity(ies) of the Design-Build Team to perform guarantee work within the terms of this provision shall be just cause to remove the responsible entity(ies) from the Department's corresponding prequalified list. The Design-Build Team will be removed for a minimum of 6 months and will be reinstated only after all work has been corrected and the Design-Build Team requests reinstatement in writing.

To ensure uniform application statewide the Division Engineer will forward details regarding the circumstances surrounding any proposed guarantee repairs to the Chief Engineer for review and approval prior to the work being performed.

DB1 G145

OUTSOURCING OUTSIDE THE USA (9/21/04)

All work on consultant contracts, services contracts, and construction contracts shall be performed in the United States of America. No work shall be outsourced outside of the United States of America.

Outsourcing for the purpose of this provision is defined as the practice of subcontracting labor, work, services, staffing, or personnel to entities located outside of the United States.

The Secretary of Transportation shall approve exceptions to this provision in writing.

DB1 G150

DISQUALIFICATION OF BIDDERS (11/16/04)

The 2002 *Standard Specifications* are revised as follows:

Page 1-17 Article 102-16, replace No.12 with the following:

12. Failure to submit the documents required by Article 109-10 within 60 days after request by the Engineer.

Page 1-18 Article 102-16, add the following after Number 15.

16. False information submitted on any application, statement, certification, report, records and/or reproduction.

Conviction of any employee of company, of any applicable state or federal law, may be fully imputed to the business firm with which he is or was associated or by whom he was employed or with the knowledge or approval of the business firm or thereafter ratified by it.

17. Being debarred from performing work with other city, state, and federal agencies.
18. Failure to perform guaranty work within the terms of the contract.

DB1 G155

REJECTION OF BIDS (12-20-05)

Revise the 2002 *Standard Specifications* as follows:

Page 1-17, Article 102-15, add the following after the third paragraph:

All proposers shall comply with all applicable laws regulating the practice of general contracting as contained in *Chapter 87 of the General Statutes of North Carolina* which requires the bidder to be licensed by the N.C. Licensing Board for Contractors when bidding on any non-federal aid project where the bid is \$30,000 or more, except for certain specialty work as determined by the licensing board. Proposers shall also comply with all other applicable laws regulating the practices of electrical, plumbing, heating and air conditioning and refrigeration contracting as contained in *Chapter 87 of the General Statutes of North Carolina*. Notwithstanding the limitations on bidding, the proposer who is awarded any project shall comply with *Chapter 87 of the General Statutes of North Carolina* for licensing requirements within 60 calendar days of bid opening, regardless of funding sources.

DB1G175

EROSION & SEDIMENT CONTROL/STORMWATER CERTIFICATION (1-17-06)**GENERAL**

Schedule and conduct construction activities in a manner that will minimize soil erosion and the resulting sedimentation and turbidity of surface waters. Comply with the requirements herein regardless of whether or not an NPDES permit for the work is required.

Establish a chain of responsibility for operations and subcontractor's operations to ensure that the *Erosion and Sediment Control/Stormwater Pollution Prevention Plan* is implemented and maintained over the life of the contract.

Certified Supervisor – Provide a certified Erosion & Sediment Control Stormwater Supervisor to direct the Design-Build Team and subcontractor(s) operations, insure compliance with Federal, State and Local ordinances and regulations, and to direct the Quality Control Program. **Certified supervisors will be required on all projects let after December 31, 2005.**

Certified Foreman – Provide certified, trained foremen for each construction operation that increases the potential for soil erosion or the possible sedimentation and turbidity of surface waters. **Certified foremen will be required on all projects let after December 31, 2005.**

Certified Installer – Provide a certified installer to install or direct the installation for erosion or sediment/stormwater control practices. **Certified installers will be required on all projects let after December 31, 2006.**

OBTAINING CERTIFICATION

Certified Supervisor – Obtain certification by completing a one day Erosion & Sediment/Stormwater Control Site Management Level II training class and passing the required exam provided by North Carolina State University, Department of Biological and Agricultural Engineering. The certification is valid for three years.

Certified Foreman – Obtain certification by completing the one-day Erosion & Sediment Control Stormwater Site Management Level II training course and passing the required exam provided by North Carolina State University, Department of Biological and Agricultural Engineering. The certification is valid for three years.

Certified Installer – Obtain certification by completing a one day Erosion & Sediment Control Stormwater Inspector/Installer Level I training course and passing the required exam provided by North Carolina State University, Department of Biological and Agricultural Engineering. The certification is valid for three years.

ROLES AND RESPONSIBILITIES

Certified Erosion & Sediment Control Stormwater Supervisor

1. The Certified Supervisor shall be responsible for ensuring erosion and sediment/stormwater control is adequately implemented and maintained on the project and conducting the quality control program.

The Certified Supervisor shall be on the project within 24 hours from initial disturbance of erosion to the project's final acceptance when questions or concerns arise with Erosion and Sedimentation Control/Stormwater issues.

Perform the following duties:

Coordinate and schedule the work of subcontractors so erosion and sediment/stormwater control measures are fully executed for each operation and in a timely manner over the duration of the contract.

Oversee the work of subcontractors so that appropriate erosion and sediment/stormwater control preventive measures are conformed to at each stage of the work.

Prepare the required weekly erosion control punchlist and present it to the Engineer.

Attend all weekly or monthly construction meetings to discuss the findings of the NPDES inspection log and other related issues.

Implement the erosion and sediment/stormwater control site plans requested.

Provide for erosion and sediment/stormwater control methods for Design-Build Team's temporary work not shown on the plans, such as, but not limited to work platforms, temporary construction, pumping operations, plant and storage yards, and cofferdams.

Acquire applicable permits and comply with requirements for borrow pits, dewatering, and any temporary work conducted by the Design-Build Team in jurisdictional areas.

Conduct all erosion and sediment/stormwater control work in a timely and workmanlike manner.

Fully install erosion and sediment/stormwater control work prior to suspension of the work.

Coordinate with NCDOT, Federal, State and Local Regulatory agencies on resolution of erosion and sediment/stormwater control issues due to the Design-Build Team's operations.

Ensure that proper cleanup occurs from vehicle tracking on paved surfaces and/or any location where sediment leaves the Right-of-Way.

Have available an easily understandable updated set of EC plans for review by the project personnel, REU, Field Ops or Regulatory Agencies.

2. Quality Control Program

Maintain a quality control program to control erosion, prevent sedimentation and follow provisions of permits. The quality control program shall:

Follow permit requirements related to the Design-Build Teams' and subcontractor(s)' construction activities.

Ensure that all operators and/or subcontractor(s) on site have the proper erosion and sediment/stormwater control certification.

Notify the Engineer when the required certified erosion and sediment/stormwater control personnel are not available on the job site when needed.

Conduct the inspections required by the NPDES permit.

Maintain the NPDES inspection log.

Take corrective actions in the proper timeframe as required by the NPDES permit for problem areas identified during the NPDES inspections.

Incorporate erosion control into the work in a timely manner and stabilize disturbed areas with mulch/seed or vegetative cover on a section-by-section basis.

Maintain temporary erosion and sediment control devices.

Remove temporary erosion or sediment control devices when they are no longer necessary as agreed upon by the Engineer.

The Design-Build Team's quality control and inspection procedures shall be subject to review by the Engineer. Maintain NPDES inspection records at the project site. Make NPDES inspection records available at all times for verification by the Engineer.

Certified Foreman

At least one Certified Foreman shall be onsite for each type of work listed herein during the respective construction activities to control erosion, prevent sedimentation and follow permit provisions:

Foreman in charge of grading activities

Foreman in charge of bridge or culvert construction over jurisdictional areas

Foreman in charge of utility activities

Certified Installers

Provide at least one certified installer for each of the following erosion or sediment/stormwater control crews:

Seeding and Mulching

Temporary Seeding

Temporary Mulching

Sodding

Silt fence or other perimeter erosion/sediment control device installations

Erosion control blanket installation

Hydraulic tackifier installation

Turbidity curtain installation

Rock ditch check/sediment dam installation

Ditch liner/matting installation

Inlet protection

Riprap placement

Stormwater BMP installations (such as but not limited to level spreaders, retention/detention devices)

Pipe installations within jurisdictional areas

PRECONSTRUCTION MEETING

Furnish the names of *the Certified Erosion & Sediment Control Stormwater Supervisor, Certified Foremen*, and notify the Engineer of changes in certified personnel over the life of the contract within 2 days of change.

REVOCAION OR SUSPENSION OF CERTIFICATION

Upon recommendation of the NCDOT Director of Construction to the Certification entity, certification for Supervisor, Certified Foremen, and Certified Installers may be revoked or suspended with the issuance of a Continuing Immediate Corrective Action (Continuing ICA), Notice of Violation, or Cease and Desist Order for erosion and sediment control/stormwater related issues.

The Department of Transportation recognizes the imperative need to have qualified individuals constructing, maintaining, and performing oversight of erosion and sediment control/stormwater components within all transportation facility projects. This accountability and competence is required to assure that the environmental commitments into which the Department has entered are in conformity with the requirements of the approved plans, specifications, and permit conditions. To ensure that candidates are qualified to construct, maintain, and oversee environmental related operations, certification programs have established written and/or proficiency standards. The certification issued jointly by the North Carolina Department of Transportation and North Carolina State University is a privileged certification that should be held in high regard. Should any of the following circumstances occur, the Director of Construction may suspend or permanently revoke such certification.

Failure to adequately perform the duties as defined within the certification program

Issuance of a continuing ICA, NOV, or Cease and Desist Order

Failure to fully perform environmental commitments as detailed within the permit conditions and specifications

Demonstration of erroneous documentation or reporting techniques

Cheating or copying another candidate's work on an examination

Intentional falsification of records

Directing a subordinate under direct or indirect supervision to perform any of the above actions

Dismissal from a company for any of the above reasons

Suspension or revocation of one's certification within another state

Suspension or revocation of a certification will be sent by certified mail to the registrant and the Corporate Head of the company that employs the registrant.

A registrant has the right to appeal any adverse action which results in suspension or permanent revocation of certification by responding, in writing, to the Director of Construction within 10 calendar days after receiving notice of the proposed adverse action.

Director of Construction
1520 Mail Service Center
Raleigh, NC 27699-1520

Failure to appeal within 10 calendar days will result in the proposed adverse action becoming effective on the date specified on the certified notice. Failure to appeal within the time specified will result in a waiver of all future appeal rights regarding the adverse action taken. The registrant will not be allowed to perform duties associated with the certification during the appeal process.

The Director of Construction will hear the appeal and make a decision within 7 days of hearing the appeal. Decision of the Director of Construction shall be final and shall be made in writing to the registrant.

If a certification is temporarily suspended, the registrant must pass any applicable written examination and any proficiency examination, at the conclusion of the specified suspension period, prior to having the certification reinstated.

Any company performing work for the North Carolina Department of Transportation has the ethical responsibility to fully disclose any reprimand or dismissal of an employee resulting from improper testing or falsification of records.

MEASUREMENT AND PAYMENT

Certified Erosion & Sediment Control Stormwater Supervisor is incidental to the project for which no direct compensation will be made.

Certified foremen are incidental to the project for which no direct compensation will be made.

Certified installers are incidental to the project for which no direct compensation will be made.

DB1G180

CLEARING AND GRUBBING

Perform clearing on this project to the limits established by Method "III" shown on Standard No. 200.03 of the Roadway Standards.

The 2002 Standard Specifications shall be revised as follows:

Page 2-3, Article 200-5

Delete the first sentence of this article and insert the following:

The property owner will have no right to use or reserve for his use any timber on the project. All timber cut during the clearing operations is to become the property of the Design-Build Team, and shall be either removed from the project by him, or else shall be satisfactorily disposed of as hereinafter provided.

DB2 R01

BUILDING AND APPURTENANCE REMOVAL/DEMOLITION (9-27-05)

Remove or demolish all buildings and appurtenances, unless otherwise noted in the GeoEnvironmental Scope of Work, within the right-of-way limits proposed by the Design-Build Team and agreed upon by the Department, in accordance with Sections 210 and 215 of the *Standard Specifications* and the following:

- Prior to removal or demolition of any building, comply with the notification requirements of *Title 40 Code of Federal Regulations*, Part 61, Subpart M, which are applicable to asbestos. Give notification to the North Carolina Department of Health and Human Services, Division of Public Health Epidemiology Branch and/or the appropriate county agency when the county performs enforcement of the Federal Regulation. Submit a copy of the notification to the Engineer prior to the any building removal or demolition.
- Perform removal and disposal of asbestos in accordance with the requirements of *Title 40 Code of Federal Regulations*; comply with all Federal, State and local regulations when performing building removal and/or asbestos removal and disposal. Any fines resulting from violations of any regulation are the sole responsibility of the Design-Build Team and the Design-Build Team agrees to indemnify and hold harmless the Department against any assessment of such fines.
- It will be the responsibility of the Design-Build Team to perform all asbestos assessment for buildings and appurtenances located within the right-of-way limits proposed by the Design-Build Team. The cost of all asbestos assessments required shall be borne by the Design-Build Team and included in the lump sum bid cost for the project. The cost of asbestos removal and disposal will be paid for in accordance with Article 104-7 of the Standard Special Provisions, Division 1 (found elsewhere in this proposal). When a building has had or will have asbestos removed and the Design-Build Team elects to remove the building such that it becomes a public area, the Design-Build Team is responsible for any additional costs incurred including final air monitoring.

DB2 R12

EMBANKMENT MONITORING (1-20-06)**SETTLEMENT GAUGES:**

Settlement plates consisting of wood or metal shall be placed on a level surface near natural ground as shown in the plans. Extend a 2½" (63.5 mm) ø metal pipe by adding pipe sections at threaded couplings as the embankment is progressed. Make sure that the top of the extension section is no less than 1 ft. (0.3 m) above the embankment surface and no higher than 6 ft (1.8 m). Compact fill around the gauge pipes and plates to the same density as the surrounding material. Make the exposed length of pipe conspicuous to avoid chance of damage.

Conduct operations in such a manner that the gauges are not damaged. Restore or replace any settlement gauge pipe damaged or destroyed due to fault or negligence on the part of the Design-Build Team at no additional cost. No additional payment will be made for compaction of fill around and over the settlement gauges or for interference with the Design-Build Team's

operations resulting from settlement gauge installations. Perform installation operations such that the 2½" (63.5 mm) ø pipe remains plumb.

Provide ASTM A53 type F 2½" (63.5 mm) ø pipe, threaded with a black finish.

MONITORING:

Settlement gauges shall be installed before any fill is placed. Settlement gauge elevations are to be surveyed weekly by the Design-Build Team. The initial elevation of the settlement gauge plate (at the top of the plate) shall be determined at the time of installation along with the embankment elevation. When new sections of pipe are added, elevations shall be recorded at the top of existing pipe and at the top of the new pipe. This is to take into account interim settlement, variable pipe lengths and thread lengths in coupling. Results of settlement gauge readings shall be forwarded to NCDOT Geotechnical Engineering Unit along with the letter by the prequalified geotechnical firm releasing the embankment from the waiting period.

DB2 R75

PRICE ADJUSTMENTS FOR ASPHALT BINDER (11-21-00)

Adjustments will be made to the payments due the Design-Build Team for each grade of asphalt binder when it has been determined that the monthly average terminal F.O.B. Selling Price of asphalt binder, Grade PG 64-22, has fluctuated from the Base Price Index for Asphalt Binder included in this Project Special Provision. The methods for calculating a Base Price Index, for calculating the monthly average terminal F.O.B. Selling Price and for determining the terminals used are in accordance with procedures on file with the Department's Construction Unit.

When it is determined that the monthly average terminal F.O.B. Selling Price of asphalt binder on the first business day of the calendar month during which the last day of the partial payment period occurs, varies either upward or downward from the Base Price Index, the partial payment for that period will be adjusted. The partial payment will be adjusted by adding the difference (+ or -) of the base price index subtracted from the monthly selling price multiplied by the total theoretical quantity of asphalt binder authorized for use in the plant mix placed during the partial payment period involved.

The Base Price Index for this project is \$ INCLUDED IN FINAL RFP per ton.

DB6 R25

PRICE ADJUSTMENTS - ASPHALT CONCRETE PLANT MIX (2-6-06)

Revise the 2002 Standard Specifications as follows:

Page 6-20, Article 609-8 and Page 6-36, Article 610-13

Add the following paragraph before the first paragraph:

The "Asphalt Price" used to calculate any price adjustments set forth in this section shall be \$35 per theoretical ton. This price shall apply for all mix types.

DB6 R26

GENERAL

The State will not be bound by oral explanations or instructions given at any time during the bidding process or after award. Only information that is received in response to this RFP will be evaluated; reference to information previously submitted will not suffice as a response to this solicitation.

NO CONTACT CLAUSE

To ensure that information is distributed equitably to all short-listed Design-Build Teams, all questions and requests for information shall be directed to the State Contract Officer through the Design-Build e-mail address, (designbuild@dot.state.nc.us). This precludes any Design-Build Team Member, or representative, from contacting representatives of the Department, other State Agencies or Federal Agencies either by phone, e-mail or in person concerning the Design-Build Project.

USE OF TERMS

Throughout this Request For Proposals and all manuals, documents and standards referred to in the Request For Proposals the terms Contractor, Bidder, Design-Builder, Design-Build Team, Team, Firm, Company, and Proposer are synonymous. Throughout this Request For Proposals and all manuals, documents and standards referred to in the Request For Proposals, the terms NCDOT, Department, Engineer, and State are synonymous.

DESIGN REFERENCES

Design references developed and published by NCDOT and those developed and published by other agencies and adopted for use by NCDOT which are to be used in the design of this project may be obtained by contacting the Contract Office of the Project Services Unit. Standard prices for materials, which the Department normally sells for a fee, will be in effect. The Design-Build Team is responsible for designing in accordance with the applicable documents and current revisions and supplements thereto.

REVIEW OF SUBMITTALS

Major design milestones and required design submittals shall be identified as activities on a CPM, bar chart, or other scheduling tool. This schedule shall be submitted to the State Alternative Delivery Systems Engineer and Resident Engineer concurrently with the first design submittal, or within 30 days of the contract award, whichever is earlier. The schedule shall be revised and resubmitted as design milestones change or as directed by the State Alternative Delivery Systems Engineer. Submittals will be reviewed within 10 working days (15 days for temporary structures) from the date of receipt by NCDOT unless otherwise stipulated in the scope of work. All submittals shall be prepared and submitted in accordance with the "*Design-Build Submittal Guidelines*", which by reference are incorporated and made a part of this contract. All submittals shall be made simultaneously to the State Alternative Delivery Systems Engineer and the Resident Engineer. The Department will not accept subsequent submittals until prior submittal reviews have been completed for that item. The Design-Build Team shall prioritize submittals in the event that multiple submittals are made based on the current schedule.

All submittals shall include pertinent Special Provisions. No work shall be performed prior to Department review of the design submittals.

OVERVIEW

The project consists of widening the existing two-lane roadway to a four-lane divided facility with a 46-foot median. Intersection access management and partial control of access are included in the proposed improvements. The project is located in Union County.

Project services shall include but are not limited to:

- **Design Services** – completion of construction plans
- **Construction Services** – necessary to build and ensure workmanship of the designed facility.
- **Permit Modification**
 - The EA was approved on May 24, 1994.
 - The FONSI was completed on September 29, 1994
 - A reevaluation of the EA and FONSI was completed on August 31, 2004
- **Right of Way** – acquisition of right of way necessary to construct project.

GENERAL SCOPE

The scope of work for this project will include design, construction and management of the project. The design work will include all aspects to widen the existing two-lane roadway to a four-lane divided facility. The designs shall meet all appropriate latest versions of *AASHTO Policy on Geometric Design of Highways and Streets*, *AASHTO Standard Specifications for the Design of Highway Bridges*, *Manual of Uniform Traffic Control Devices*, and all NCDOT design criteria.

Construction will include, but not be limited to, all necessary roadway, drainage, utility coordination, and erosion and sediment control work items. Construction engineering and management will be the responsibility of the Design-Build Team. Construction will comply with *NCDOT Standard Specifications for Roadways and Structures Edition of 2002* and any special provisions.

Areas of work required for this project will include, but are not limited to the following items:

- Roadway Design
- Preliminary and Final Bridge Design
- Culvert Design
- Hydraulics / Drainage Design
- Foundation Design for Structures and Roadway
- Erosion and Sediment Control Design and Implementation
- Lime and Cement Stabilization
- Permit Modification

R/W Utilities, Conflicts and Construction
Traffic Control and Pavement Marking Plans and Implementation
Sign Design
Construction and Construction Management
Project Management
Construction Surveying
R/W Acquisition
Public Involvement
Supplemental Surveys

All designs shall be in Microstation format using Geopak software (current version used by the Department)

DESIGN AND CONSTRUCTION PERFORMED BY DESIGN-BUILD TEAM

The design work consists of the preparation of all construction documents for widening US 601 from north of the South Carolina State Line to north of Marion Lee Road (SR 2105) as outlined in the Scope of Work section of this package. The Design-Build Team shall prepare final designs, construction drawings and special provisions.

The Design-Build Team is cautioned that project documents furnished by the Department are preliminary and provided solely to assist the Design-Build Team in the development of the project design. The Design-Build Team shall be fully and totally responsible for the accuracy and completeness of all work performed under this contract and shall save the State harmless and shall be fully liable for any additional costs and all claims against the State which may arise due to errors, omissions and negligence of the Design-Build Team in performing the work.

There shall be no assignment, subletting or transfer of the interest of the Design-Build Team in any of the work covered by the Contract without the written consent of the State, except that the Design-Build Team may, with prior notification of such action to the State, sublet property searches and related services without further approval of the State.

The Design-Build Team shall certify all plans, specifications, estimates and engineering data furnished by the Team.

All work by the Design-Build Team shall be performed in a manner satisfactory to the State and in accordance with the established customs, practices, and procedures of the North Carolina Department of Transportation, and in conformity with the standards adopted by the American Association of State Highway Transportation Officials, and approved by the Secretary of Transportation as provided in Title 23, US Code, Section 109 (b). The decision of the Engineer/State/Department shall control in all questions regarding location, type of design, dimension of design, and similar questions.

Alternate designs, details, or construction practices (such as those employed by other states, but not standard practice in NC) are subject to Department review and will be evaluated on a case by case basis.

The Design-Build Team shall not change team members, subconsultants or subcontractors identified in the RFQ or RFP without written consent of the Engineer. In addition,

subconsultants and subcontractors not identified in the RFQ or RFP shall not perform any work without written consent by the Engineer. Individual offices of the Design-Build Team not identified in the Statement of Qualifications or the Technical Proposal submittal shall not perform any work without written consent by the Engineer. Failure to comply with this requirement may be justification for removing the Team from further consideration for this project and disqualification from submitting on future Design-Build Projects.

The Department shall prequalify all firms for the work they are identified to perform. Design firms and Natural Systems firms are prequalified by the particular office performing the work. If the work shall be performed by an office other than the one that is prequalified, that office shall be prequalified prior to any design submittals

ETHICS POLICY

Employees employed by the Design-Build Team or employees employed by any subconsultant for the Design-Build Team to provide services for this project shall comply with the Department's ethics policy. Failure to comply with the ethics policy will result in the employee's removal from the project and may result in removal of the Company from the Department's listing of Registered Qualified Engineering Firms.

APPROVAL OF PERSONNEL

The Department will have the right to approve or reject any personnel, assigned to a project by the Design-Build Team.

The Design-Build Team or any subcontractor for the Design-Build Team which are employed to provide services for this project shall not discuss employment opportunities or engage the services of any person or persons, now in the employment of the State during the time of this contract, without written consent of the State.

In the event of engagement, the Design-Build Team or their subcontractors shall restrict such person or persons from working on any of the Design-Build Team's contracted projects in which the person or persons were "formerly involved" while employed by the State. The restriction period shall be for the duration of the contracted project with which the person was involved. *Former Involvement* shall be defined as active participation in any of the following activities:

- Drafting the contract
- Defining the scope of the contract
- Selection of the Design-Build Team
- Negotiation of the cost of the contract (including calculating manhours or fees); and
- Administration of the contract.

An exception to these terms may be granted when recommended by the Secretary and approved by the Board of Transportation.

Failure to comply with the terms stated above in this section shall be grounds for termination of this contract and / or not being considered for selection of work on future contracts for a period of one year.

SUBMITTAL OF TECHNICAL AND PRICE PROPOSALS**GENERAL**

Technical and Price Proposals will be accepted until **4:00 P.M. Local Time on Tuesday, June 13, 2006**, at the office of the State Contract Officer:

Mr. Randy A. Garris, PE
Project Services Unit
1020 Birch Ridge Drive
Century Center Complex Bldg. B
Raleigh, NC

No Proposals will be accepted after the time specified.

Proposals shall be submitted in 2 separate, sealed parcels containing the Technical Proposal in one and the Price Proposal in the other parcel.

TECHNICAL PROPOSAL

Technical Proposals shall be submitted in a sealed package. The outer wrapping shall clearly indicate the following information:

Technical Proposal
Submitted By: (Design-Build Team's name)
Contract Number C201304
TIP Number R-2616
Union County
US 601 from north of the South Carolina State Line to north of SR 2105

Technical Proposal Requirements
12 Copies
8 ½ inch by 11 inch pages
No fold-out sheets allowed
Printed on one side only
Double-spaced
Font size 12
No more than 50 pages, excluding the 11 inch by 17 inch appropriate plan sheets

Key Project Team members, identified in the Request For Qualifications, shall not be modified in the Technical Proposal without written approval of the Department. Any such request should be sent to the attention of Mr. Randy Garris, PE, at the address below:

NCDOT-Project Services Unit
Century Center-Building B
1020 Birch Ridge Drive
Raleigh, NC 27610

PRICE PROPOSAL

Price Proposals shall be submitted in a sealed package. The outer wrapping will clearly indicate the following information:

Price Proposal
Submitted by (Design-Build Team's Name)
Contract Number C201304
TIP Number R-2616
Union County
US 601 from north of the South Carolina State Line to north of SR 2105

The Price Proposal shall be submitted by returning the Request For Proposals with the item sheets completed, and all required signatures and bonds. Failure to execute the required documents may render the proposal non-responsive. If DBE goals are not met, documents related to Good Faith efforts shall be submitted with the Price Proposal

EVALUATIONS

Technical Proposals shall address the technical elements of the design and construction of the project. The Technical Review Committee will consider the understanding of the project, the anticipated problems and the solutions to those problems.

The Design-Build Team's Technical Proposal shall be developed using narratives, tables, charts, plots, drawings and sketches as appropriate. The purpose of the Technical Proposal is to document the firm's understanding of the project, their selection of appropriate design criteria, and their approach for completing all design and construction activities.

The award of the Design-Build contract does not in any way imply that the Department accepts or approves the details of the Technical Proposal submitted by the Design-Build Team. Decisions based on cost alone will not establish the design standards for the project. The proposal will be evaluated in each of the following areas:

EVALUATION FACTORS	POINTS
1. Management	23
2. Responsiveness to Request for Proposal	26
3. Long Term Maintenance	8
4. Schedule and Milestones	15
5. Innovation	5
6. Maintenance of Traffic and Safety Plan	18
7. Oral Interview	5

TECHNICAL PROPOSAL EVALUATION CRITERIA**1. Management – 23 points*****Design-Build Team Management – 10 points***

- Describe the Design-Build Team's concept of design management. The proposal shall identify key positions and subordinate organizational units.

- Describe the plan for the coordination of civil / structural, utilities, traffic maintenance, constructability and environmental responsibility.
- Provide a narrative description of the proposed location of the design office(s) and their respective responsibilities.
- Describe how the designs developed by different firms and offices will be integrated.
- Describe how design personnel will interface with the construction personnel.
- Describe the overall strengths of the Design Team and their ability to fulfill the design requirements of this project.

Quality Management - 5 Points

- Describe how the Design-Build Team will comply with the quality control requirements for both design and construction. Specifically, include a narrative describing the Design-Build Team's understanding of the Department's construction quality control philosophy for this project and how the Design-Build Team will implement it.
- The Design-Build Team should detail the number of inspectors they expect the Department to furnish, during various phases, to allow satisfactory progress of project construction.
- The narrative shall include both design and construction activities.

Construction Management - 8 Points

- Describe the Design-Build Team's concept of the project construction management organization and how it interrelates with the other elements of the Design-Build Team's organization for the project.
- Provide a brief narrative description of the Design-Build Team's proposed plan for performing construction on the project. This description shall include at least the following:
 - A construction organization chart for the project, showing the relationships between functions shown on the chart and the functional relationships with subcontractors.
 - The chart shall indicate how the Design-Build Team intends to divide the project into work segments to enable optimum construction performance.
 - Descriptions of those categories of work that the Design-Build Team anticipates will be performed by the Design-Build Team's own direct labor force and those categories that will be performed by subcontractors.
 - The Design-Build Team's plans and procedures to insure timely deliveries of materials to achieve the project schedule.
 - Describe the overall strengths of the construction team and their ability to fulfill the construction management requirements of this project.

2. Responsiveness to RFP – 26 points

Disadvantaged Business Enterprises (DBE) - 2 Points

- Describe the Design-Build Team's approach to ensuring that DBE will have opportunity to participate in the design aspect of the project.

- DBE firms, to be utilized in the design shall be noted in the RFP submittal.
- It is expected that DBE design will be at least 5% of the overall design cost.
- The overall approach to ensuring DBE participation in all areas of work also needs to be addressed.

Natural Environmental Responsibility – 7 Points

- Describe the Design-Build Team's approach to addressing environmental concerns within the project boundaries.
- Identify efforts to minimize impacts on wetlands, streams, riparian buffers, and other environmentally sensitive areas.
- Identify innovative approaches to minimize any impacts in environmentally sensitive areas. Describe any temporary impacts and associated minimization approaches.
- Describe the Design-Build Team's understanding of the overall approach to permitting and the Team's comfort level with obtaining the required permit application / modification within the allowed timeframe.
- Identify methods of construction in wetlands and buffers.
- Describe any Notice of Violations (NOV's) or Immediate Corrective Actions (ICA's) the Design-Build Team has received and the disposition of any NOV's or ICA's.
- Describe the Design-Build Teams approach to Sedimentation and Erosion Control for the project.
- Describe efforts to minimize excavation within the contaminated sites and associated disturbance to underlying soil.

Design Features – 17 points

- Show plan view of design concepts with key elements noted.
- Identify preliminary horizontal and vertical alignments of all roadway elements.
- Show typical sections for the mainline of the project.
- Identify drainage modifications and designs to be implemented.
- Identify the appropriate design criteria for each feature if not provided.
- Identify all bridge types to be constructed, including any special design features or construction techniques needed.
- Identify any deviations, including proposed design exceptions, from the established design criteria that will be utilized. Explain why the deviation is necessary. Describe any Geotechnical investigations to be performed by the Design-Build Team.
- Identify any special aesthetics considerations that will be part of the design..
- Describe how any utility conflicts will be addressed and any special utility design considerations.
- Identify types of any retaining walls and /or noise walls if applicable.

3. Long Term Maintenance – 8 points

- Describe any special materials, not referenced elsewhere in the contract, incorporated into the project that would result in long term reduction in maintenance.
- Describe any special designs or construction methods that would reduce future maintenance costs to the Department.

- Estimate a minimum ten-year cost savings resulting from incorporation of these special materials, design, or construction methods into the project.

4. Schedule and Milestones – 15 points

- Provide a schedule for the project including both design and construction. The schedule shall show the sequence and continuity of operations, as well as the month of delivery of usable segments of the project.
- The schedule shall also include the Design-Build Team's final completion date and, if proposed, their substantial completion date. **These dates shall be clearly indicated on the Project Schedule and labeled "Final Completion Date" and "Substantial Completion Date".**

5. Innovation – 5 points

Identify any aspects of the design or construction elements that the Design-Build Team considers innovative. Include a description of alternatives that were considered whether implemented or not.

6. Maintenance of Traffic and Safety Plan – 18 points

Maintenance of Traffic

- Describe any traffic control requirements that will be used for each construction phase.
- Describe how traffic will be maintained as appropriate and describe the Design-Build Team's understanding of any time restrictions noted in the RFP.
- Specifically describe how business and residential access will be maintained, if applicable.

Safety Plan

- Describe the safety considerations specific to the project.
- Discuss the Design-Build Team's overall approach to safety.
- Describe any proposed improvements that will be made prior to or during construction that will enhance the safety of the work force and/or travelling public both during and after the construction of the project.

7. Oral Interview – 5 points

- The Design-Build Team's Project Management Team shall present a brief introduction of the project team and design / construction approach.
- Introductory comments shall be held to no more than 30 minutes.
- The Department will use this interview to ask specific questions about the Team's background, philosophies, and approach to the project.
- Presentation, questions, and answers shall not exceed 90 minutes. No more than 10 people from the Design-Build Team may attend.

The Department will use the information presented in the oral interview to assist in the evaluation of the Technical Proposal.

Additional Warranty and / or Guarantee

- **The Extra Credit for this project shall be a Maximum of (6) Points.**

A twelve-month guarantee as outlined in the *Twelve-Month Guarantee* provision shall be required for this project. However, the Design-Build Team may provide additional warranties and / or guarantees at their discretion. The Design-Build Team may be awarded additional points as “extra credit” to be added to the technical score.

The Design-Build Team may provide warranties and / or guarantees for major components of the project. Examples of major components are pavements, bridge components, and sign structures. If additional warranties and / or guarantees are offered, the Design-Build Team shall indicate in the Technical Proposals the general terms of the warranties and / or guarantees, a list of the items covered, performance parameters, notification and response parameters for corrective action, and evaluation periods. The Department will be responsible for annual inspections of the components covered by all warranties and / or guarantees offered by the Design-Build Team that extend beyond the required Twelve-Month Guarantee. The warranties and / or guarantees shall also define how disputes will be handled. Prior to the first partial payment, the Design-Build Team shall submit a document that provides additional warranty / guarantee specifics in sufficient detail that allows the document to be made a part of the contract through supplemental agreement.

No direct payment will be made for warranties and / or guarantees. Payment will be considered incidental to the lump sum price for the contract.

SELECTION PROCEDURE

There will be a Technical Review Committee (TRC) composed of Project Managers, and three or more senior personnel from involved engineering groups that will evaluate the Technical Proposal on the basis of the criteria provided in the Request For Proposals.

The selection of a Design-Build Team will involve both technical quality and price. The Technical Proposals will be presented to the TRC for evaluation. The TRC shall first determine whether the proposals are responsive to the requirements of the Request For Proposals. Each responsive Technical Proposal shall be evaluated based on the rating criteria provided in the Request For Proposals. The TRC will submit an overall Technical Proposal score for each firm to the State Contract Officer. A maximum quality credit percentage will be assigned for each project, as determined by the TRC.

Quality Credit Evaluation Factors for Technical Proposals

Management	23
Responsiveness to Request for Proposal	26
Long Term Maintenance	8
Schedule and Milestones	15
Innovation	5
Maintenance of Traffic and Safety Plan	18
Oral Interview	5
Maximum Score	100

The State Contract Officer will use a table based on the maximum quality credit percentage to assign a Quality Credit Percentage to each proposal based on the proposal's overall technical score. The maximum percentage for this project will be **25%**.

Quality Credit Percentage for Technical Proposals

Technical Score	Quality Credit (%)	Technical Score	Quality Credit (%)
100	25.00	84	11.67
99	24.17	83	10.83
98	23.33	82	10.00
97	22.50	81	9.17
96	21.67	80	8.33
95	20.83	79	7.50
94	20.00	78	6.67
93	19.17	77	5.83
92	18.33	76	5.00
91	17.50	75	4.17
90	16.67	74	3.33
89	15.83	73	2.50
88	15.00	72	1.67
87	14.17	71	0.83
86	13.33	70	0.00
85	12.50		

The maximum Technical Score, including any extra credit given for warranties or guarantees, shall not exceed 100 points in determining the Quality Credit percentage.

If any of the Technical Proposals are considered non-responsive, the manager of the Contract Office will notify those Design-Build Teams of that fact. The Manager of the Contract Office shall publicly open the sealed Price Proposals and multiply each Design-Build Team's Price Proposal by the Quality Credit Percentage earned by the Design-Build Team's Technical Proposal to obtain the Quality Value of each Design-Build Team's Technical Proposal. The Quality Value will then be subtracted from each Design-Build Team's Price Proposal to obtain an Adjusted Price based upon Price and Quality combined. Unless all Proposals are rejected, the Department will recommend to the State Transportation Board that the Design-Build Team having the lowest adjusted price be awarded the contract. The cost of the design-build contract will be the amount received as the Price Proposal.

The following table shows an example of the calculations involved in this process.

As Example of Calculating Quality Adjusted Price Ranking

Proposal	Technical Score	Quality Credit (%)	Price Proposal (\$)	Quality Value (\$)	Adjusted Price (\$)
A	95	20.83	3,000,000	624,900	2,375,100
B	90	16.67	2,900,000	483,430	2,416,570
C *	90	16.67	2,800,000	466,760	2,333,240
D	80	8.33	2,700,000	224,910	2,475,090
E	70	0.00	2,600,000	0	2,600,000
* Successful Design-Build Team – Contract Cost \$2,800,000					

Best and Final Offer

In the event initial cost proposals exceed the Department's budget for the project or if the Department feels it is necessary for any reason the Department may choose to make amendments to the details of the RFP and request a Best and Final Offer from all of the previously shortlisted teams. Alternately, the Department may choose to redistribute to the shortlisted firms another RFP for the project with no amendments to the RFP scope.

After receipt of the redistributed RFP, the Design-Build Team has the option of changing their Technical Proposal details. If the Design-Build Team changes any component of the Technical Proposal, the TRC will review those amended components of the Technical Proposal and reevaluate the scores accordingly. The Design-Build Team shall highlight the changes to bring them to the Department's attention. A revised total score will be calculated, if appropriate, based on these amendments to the Technical Proposal.

Additional oral interviews will not be held. The Design-Build Teams will submit both a revised Price Proposal and a revised Technical Proposal (if applicable) at the time, place, and date specified in the redistributed RFP. A revised Quality Value (if required) and Adjusted Price will be determined elsewhere in the RFP. This will constitute the Design-Build Team's Best and Final Offer. Award of the project may be made to the team with the lowest adjusted price on this Best and Final Offer for the project.

Stipend

A stipulated fee of **\$45,000** will be awarded to each short-listed Design-Build Team that provides a responsive, but unsuccessful, proposal. If a contract award is not made, all short-listed Design-Build Teams that provide a responsive proposal shall receive the stipulated fee. Once award is made, or a decision is made not to award, unsuccessful Design-Build Teams will be notified of the opportunity to apply for the stipulated fee. If the Design-Build Team accepts the stipulated fee, the Department reserves the right to use any ideas or information contained in the proposals in connection with any contract awarded for the project, or in connection with any subsequent procurement, with no obligation to pay additional compensation to the unsuccessful Design-Build Team. The stipulated fee shall be paid to eligible Design-Build Teams within ninety days after the award of the contract or the decision not to award. Unsuccessful Design-Build Teams may elect to refuse payment of the stipulated fee and retain any rights to its proposal and the ideas and information contained therein.

ROADWAY SCOPE OF WORK (2-27-06)**Project Details**

- The Design-Build Team shall design and construct a four-lane divided facility with a 46-foot median, unless noted otherwise, from north of the South Carolina State Line to north of Marion Lee Road (SR 2105). The Design-Build Team shall design and construct the –L- Line providing access, widening and improvements as indicated on the Right of Way Plans. Both the southern and northern project termini shall transition to the existing five-lane curb and gutter typical sections. The limits of –L- Line construction shall be of sufficient length to tie to existing based upon the current guidelines and standards.
- US 601 shall be designed and widened to a four-lane facility that meets a 60-mph design speed for a flat rural principal arterial. The Design-Build Team shall provide all other design criteria for review prior to submittal of preliminary plans.
- The Design-Build Team shall design and construct at-grade intersections with directional crossovers along the mainline at locations shown on the Right of Way Plans. The directional crossovers shall be designed and constructed in accordance with the NCDOT's Standard Detail for Directional Median Crossover with Median U-Turn. The directional crossovers shall be designed and constructed to prevent counterflow movements, including but not limited to elongated concrete channelization on the –Y-Lines. The directional crossovers shall be signed to prevent a U-Turn maneuver. (See Signing Scope of Work.) Offset left-turn access shall be provided along the mainline as shown on the Right of Way Plans. The design vehicle for all bulb-outs shall be a WB-50.
- At the US 601 / Lansford Road intersection, the Design-Build Team shall design and construct a low / mountable concrete island. The Design-Build Team shall provide signing that indicates emergency vehicle use only.
- The Design-Build Team shall design and construct -Y- Lines and cul-de-sacs, providing access, widening and improvements as indicated on the Right of Way Plans. The limits of -Y-Line construction shall be of sufficient length to tie to existing based upon the current guidelines and standards.
- Along US 601, the Design-Build Team shall design and construct ten-foot outside shoulders, four-foot of which shall be full depth paved shoulders and six-foot median shoulders, two-foot of which shall be full depth paved shoulders.
- Along US 601, milled rumble strips shall be provided on the outside and inside paved shoulders.
- The Design-Build Team shall design and construct bridge rail offsets that are equal to or greater than the approach roadway paved shoulders.

- The Department will obtain the permits required for the project. Any variation in the Department's proposed design and or construction methods that nullify any Concurrence Point obtained through the Merger 01 Process, require additional coordination with the Environmental Agencies, and / or require a permit modification is the sole responsibility of the Design-Build Team. The Department shall not allow any contract time extensions associated with obtaining a permit modification or additional agency coordination.
- The Design-Build Team shall design and construct resurfacing grades for all roadways impacted by construction. The Design-Build Team shall design and construct grades that adhere to the design criteria and standards, providing all required pavement wedging.
- The maximum allowable cut slope or fill slope on this project shall be 2:1.
- The Design-Build Team shall design and construct reinforced grass median shoulders at locations shown on the Right of Way Plans. The reinforced shoulders shall be capable of supporting a minimum of 18,000 pounds per axle.
- The Design-Build Team shall inform NCDOT of any proposed changes to the NCDOT preliminary design or previously reviewed submittals and obtain approval prior to incorporation. The Design-Build Team shall note any proposed deviations to the preliminary design shown on the Right of Way Plans in the Technical Proposal.
- No Design Exceptions shall be allowed for the proposed four-lane facility on US 601. NCDOT prefers not to have design exceptions for the -Y- Lines. If the Design-Build Team anticipates any design exceptions, they shall be clearly noted in the Technical Proposal. Prior to requesting / incorporating a design exception, the Design-Build Team must obtain prior approval from the Department and FHWA. If approval is obtained, the Design-Build Team shall be responsible for the development and approval of all design exceptions.
- The Design-Build Team shall place rebar and caps with carsonite posts for right of way monument locations as directed by the Resident Engineer. The Department shall furnish the caps and carsonite posts in accordance with Department policy.
- The Design-Build Team shall submit Structure Recommendations and Design Criteria for NCDOT review and acceptance prior to submittal of the preliminary plans.
- There are no noise walls required on this project as currently designed. If the Design-Build Team revises the horizontal and / or vertical alignments such that greater noise impacts are possible on surrounding receptors, the Design-Build Team shall re-analyze and complete a revised noise report, if necessary, for NCDOT and FHWA review and acceptance. The original noise report (and subsequent correspondence between the Department and FHWA) will be provided to the Design-Build Team to assist in determination of anticipated additional noise impact on current receptors due to a design change. If noise walls are required as a result of design deviations, the Design-Build Team shall be responsible for all costs associated with the walls, including, but not

limited to, public involvement, geotechnical investigation, shaft and wall designs and construction.

- This is a partial control of access facility. The Design-Build Team shall bring to the Department's attention any deviations from the proposed control of access shown on the preliminary design. All parcels with 2000 feet of frontage, or less, along US 601 shall be provided only one access point. For those parcels with less than 2000 feet of frontage along US 601 and access along another roadway, access may be denied along US 601. The Design-Build Team shall be responsible for coordination with and approval by the NCDOT of the woven wire fence placement and access control break locations. The Design - Build Team shall be responsible for installation of the woven wire fence.
- The Design-Build Team shall be responsible for the evaluation of the algebraic difference in rates of cross slope (roll-over) between existing shoulders and roadways and the associated suitability for carrying traffic during construction, if necessary. In the event that the roll-over is found to be unacceptable for the proposed temporary traffic patterns, the Design-Build Team shall be responsible for providing cross slopes that meet design standards and eliminate roll-over concerns.
- All guardrail and cable guiderail placement shall be in accordance with *NCDOT Standard Drawings* and / or approved details in lieu of standards. The guardrail design shall be submitted for review with the preliminary plan submittal.
- The Design-Build Team shall design and construct concrete median barrier in front of all retaining walls and elements acting as a retaining wall that are subject to vehicular impact.

NCDOT Information Supplied

- The NCDOT will provide copies of the EA (Environmental Assessment), FONSI (Finding of No Significant Impact), Reevaluation of EA and FONSI, and the latest list of environmental commitments, municipal agreements and all pertinent approvals and correspondence. The Design-Build Team shall adhere to all commitments stated in the environmental documents.
- The NCDOT will provide electronic surveys to the Design-Build Team. Subsequent to acquiring these surveys, US 601 has been resurfaced and shoulders constructed. Any supplemental surveys, including but not limited to additional topography, existing and proposed roadway, structure sites, underground and overhead utilities, existing and proposed drainage, wetland delineation, right of way, parcel names, and deed research and descriptions shall be the responsibility of the Design-Build Team to acquire and process. Known existing utilities have been located and will be included with the survey data. All supplemental SUE work shall be the responsibility of the Design-Build Team.

- The NCDOT will provide the preliminary design for R-2616. The Design-Build Team is cautioned that the preliminary design is provided solely to assist the Design-Build Team in the development of the project design. The Design-Build Team shall be fully and totally responsible for the accuracy and completeness of the project design, including, but not limited to, the use of the NCDOT's design, the use of portions of the NCDOT's design or modifications to the NCDOT's design.
- The NCDOT will provide final pavement designs for R-2616 (Reference the Pavement Management Scope of Work). The Design-Build Team shall be responsible for all temporary pavement designs.
- The NCDOT will provide a Geotechnical Subsurface Investigation for R-2616 (Reference the Geotechnical Scope of Work). The Design-Build Team shall be responsible for any additional geotechnical information, all geotechnical recommendations, as well as supplemental structural and roadway investigations.

STRUCTURE SCOPE OF WORK (2-21-06)**Project Details**

The Design-Build Team shall be responsible for all structures necessary to complete the project. The following structures are anticipated:

- Dual Bridges on US 601 over Lanes Creek
- Reinforced concrete box culverts at locations noted below:
 - ◆ Mill Creek
 - ◆ Cowpens Branch
 - ◆ Tributary to Cowpens Branch
 - ◆ Bottomless structure at Wicker Branch

Bridge barrier rails shall be jersey shaped barriers per Standard Drawing CBR1.

Structure Removal

The Design-Build Team shall be responsible for the removal and disposal of all existing reinforced concrete box culverts. It is anticipated that the Design-Build Team shall be responsible for removal and disposal of the following structures. However, it shall be the Design-Build Team's responsibility to verify the existing structures to be removed and disposed.

- ◆ Sextuple barrel at Lanes Creek
- ◆ Triple barrel at Mill Creek
- ◆ Double barrel at Cowpens Branch
- ◆ Double barrel at Tributary to Cowpens Branch
- ◆ Double barrel at Wicker Branch

General

Design shall be in accordance with the Seventeenth Edition AASHTO Standard Specifications for Highway Bridges, NCDOT Structure Design Manual (including policy memos), and NCDOT Bridge Policy Manual. Construction and materials shall be in accordance with the 2002 NCDOT Standard Specifications For Roads and Structures, NCDOT Structure Design Unit Project Special Provisions, and NCDOT Structure Design Unit Standard Drawings.

Bridge geometry (width, length, skew, span arrangement, typical section, grade, alignment, etc.) shall match approved Bridge Survey Reports, Roadway Plans and Structure Recommendations developed by the Design-Build Team. Bridges shall meet all hydraulic design requirements for drainage.

The Design-Build Team's primary bridge design firm shall be on the Highway Design Branch's list of firms qualified for structure design and maintain and office in North Carolina.

Alternate designs, details, or construction practices (such as those employed by other states, but not standard practice in North Carolina) are subject to NCDOT review and shall be evaluated on a case by case basis.

Monotube sign support structures shall not be allowed.

If required, sound barrier wall shall be in accordance with standards SBW1 & SBW2.

Cored slab or box beam type bridges shall require a reinforced, cast in place, 4" minimum depth class AA concrete wearing surface.

PAVEMENT MANAGEMENT UNIT SCOPE OF WORK (2/21/06)

The pavement design for the mainline (US 601) new construction shall consist of one of the following alternates:

Alternate 1

3.0" S9.5C
 3.0" I19.0C
 7.5" B25.0C
 Subgrade Stabilization

Alternate 2

3.0" S9.5C
 3.0" I19.0C
 3.5" B25.0C
 8.0" ABC
 Subgrade Stabilization

Subgrade stabilization shall be to a depth of 8 inches for lime and 7 inches for cement. The type of subgrade stabilization and amount of stabilizing agent shall be determined in accordance with the "Cement and Lime Stabilization of Subgrade Soils" Scope of Work found elsewhere in this Design-Build Package. Typically, projects adjacent to this one have been stabilized with lime.

The Design-Build Team shall maintain the same pavement design for the mainline as identified above. Once the pavement design is selected, the Design-Build Team shall stay with the selected alternate throughout the project. The Design-Build Team shall specify the pavement alternate to be used in the Technical Proposal.

Other pavement designs for this project are listed in the table below:

LINE	Surface	Intermediate	Base
Mainline, widening of existing road	3.0" S9.5C	3.0" I19.0C	10.5" B25.0C
-Y1- (SR 1005) and -Y1A- (SR 2113)	1.5" SF9.5A	2.5" I19.0B	4.5" B25.0B
-Y2- (SR 1005)	1.5" SF9.5A	2.5" I19.0B	4.5" B25.0B
-Y4R- (SR 2111) and -Y5B- (SR 1940)	2.0" SF9.5A	-----	5.0" B25.0B
-Y6- and -Y7- (SR 1939)	3.0" SF9.5A	-----	4.5" B25.0B
-Y8- (SR 2110)	1.5" SF9.5A	-----	4.0" B25.0B
-Y9- (SR 1971)	1.5" SF9.5A	-----	5.0" B25.0B
-Y12- (SR 2109)	2.0" SF9.5A	-----	5.0" B25.0B
-Y13- (SR 1950)	2.0" SF9.5A	-----	5.0" B25.0B
-Y14- (SR 1952)	2.0" SF9.5A	-----	4.5" B25.0B
-Y15- (SR 2108)	2.0" SF9.5A	-----	5.0" B25.0B
Y16 (SR 2204)	3.0" SF9.5A	-----	4.5" B25.0B
Y17 (SR 2106)	1.5" SF9.5A	2.5" I19.0B	4.5" B25.0B
Y18 (SR 2105)	1.5" SF9.5A	-----	4.0" B25.0B
Y3, Y10, and Y11	1.5" SF9.5A	-----	4.0" B25.0B

The Design-Build Team shall provide SF9.5A mixes in accordance with the ASTM D 4791 requirement that they contain a maximum of 10% flat and elongated coarse aggregate.

All non-concrete driveways, up to the radius point, shall be constructed with the full-depth pavement design of the intersecting roadway. The entire length of all non-concrete driveways with a 10% or steeper grade shall be constructed with asphalt and incidental stone as noted below. All concrete driveways, up to the radius point, shall be constructed with concrete. The entire length of all concrete driveways with a 10% or steeper grade shall be constructed with concrete as noted below. The Design-Build Team shall adhere to the following for driveway construction:

For gravel drives, use 8" Incidental Stone

For asphalt drives, use 1.5" SF9.5A and 8" Incidental Stone

For concrete drives, use 6" jointed concrete reinforced with woven wire mesh

The Design-Build Team shall resurface the existing pavement with a minimum pavement depth that equals the full thickness of surface course as provided above.

Along the mainline, the Design-Build Team shall pave from the edge of the proposed paved shoulder to the face of guardrail with 6" of ABC and at least one lift of SF9.5C surface course. Along the -Y- Lines the Design-Build Team shall pave from the edge of the proposed paved shoulder to the face of guardrail with 6" ABC and at least one lift of SF9.5A surface course. Both ABC pavement designs noted above shall require prime coat at the normal application rate.

In areas where the existing paved shoulder is proposed to be incorporated into a permanent travel lane, the Design-Build Team shall be responsible for evaluating the existing paved shoulder regarding its suitability for carrying the projected traffic volumes. In the event that the existing paved shoulder is found to be inadequate, the Design-Build Team shall be responsible for removing the existing paved shoulder. The Design-Build Team shall submit their evaluation and proposed use of existing paved shoulders to the State Alternative Delivery Systems Engineer for review and approval or rejection.

The Design-Build Team shall be responsible for the design of all temporary pavements and for the evaluation of existing shoulders and roadways regarding their suitability for carrying traffic during construction, if necessary. In the event that the existing shoulders and roadways are found to be inadequate for the proposed temporary traffic volumes and durations, the Design-Build Team shall be responsible for upgrading the pavement to an acceptable level. Temporary pavements shall be designed in accordance with the most recent version of the North Carolina DOT Pavement Design Procedure. Temporary pavement designs are to be submitted for review and comment using the contract submittal process. The expected duration for traffic on temporary pavement must be included as part of the submittal.

The rate of application and the maximum and minimum thickness per application and layer shall be in accordance with the *NCDOT Roadway Design Manual*.

Shoulder drains are required for this project. If the Design-Build Team selects **Alternate 1** for the mainline new construction, the detail for shoulder drain construction shall be as follows:

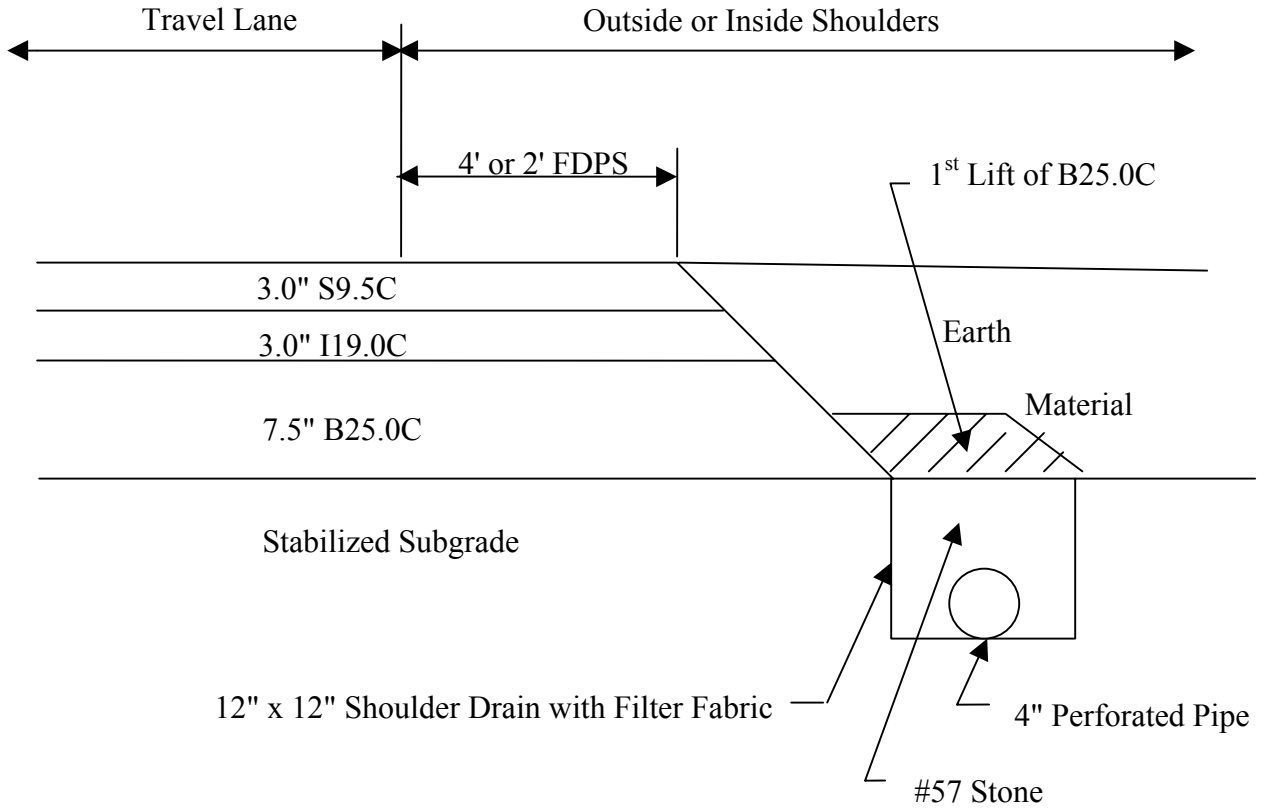

If the Design-Build Team selects **Alternate 2** for the mainline new construction, the detail for shoulder drain construction shall be as follows:

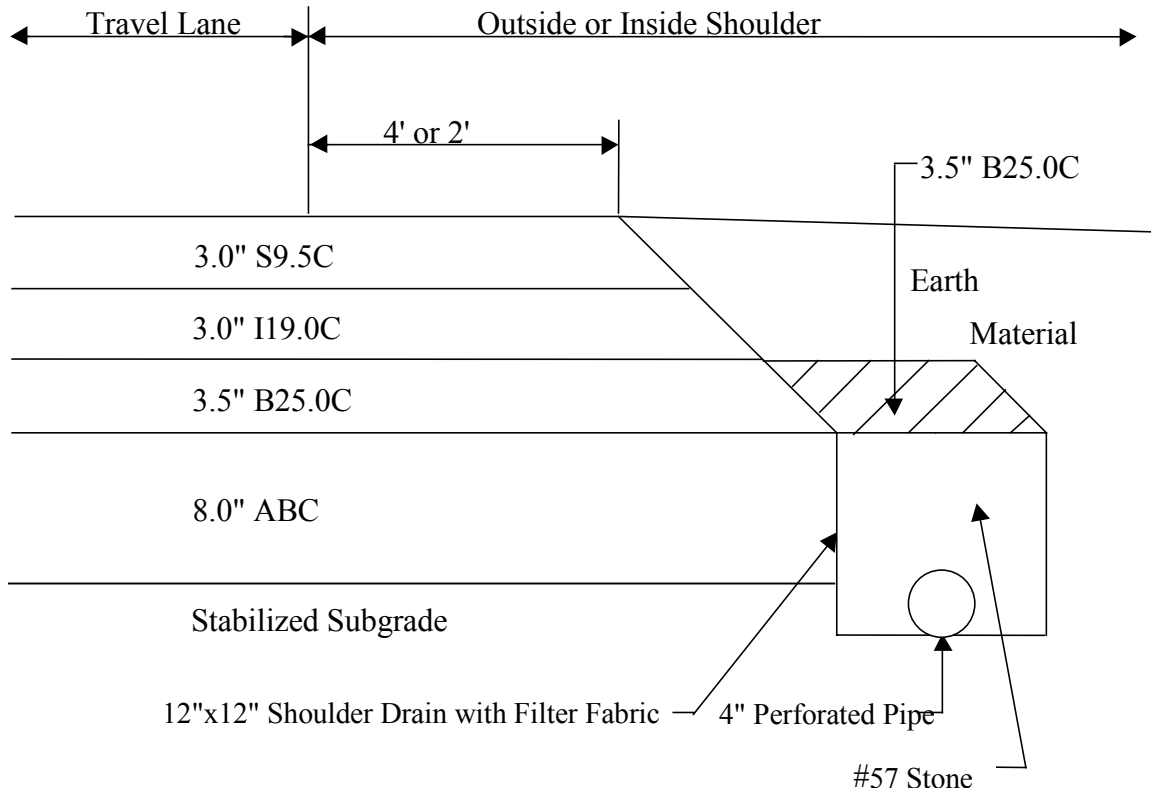

The proposed locations of shoulder drain installations for this project are listed in the table below. The Design-Build Team shall be responsible for redesigning the proposed shoulder drain locations that result from modifications to the Department’s proposed vertical alignment. If necessary, the Design-Build Team shall design shoulder drain locations in accordance with the most recent version of the NCDOT’s Pavement Design Procedures and submit the designs to the State Alternative Delivery Engineer for review and approval. The Design-Build Team shall be responsible for verifying that the following shoulder drain locations and outlets provide adequate drainage for the pavement.

LINE	SIDE	Begin Station	End Station	OUTLET LOCATIONS
-L-	NBL, Median	22+45	30+00	24+33± (2GI), 26+50 (2GI)
-L-	NBL, Outside	30+05	33+78	30+05
-L-	NBL, Outside	33+78	43+00	37+50, 39+57±
-L-	NBL, Outside	117+00	119+83	117+00
-L-	NBL, Median	120+50	124+69	120+50 (2GI)
-L-	NBL, Median	124+69	128+25	128+25 (2GI)
-L-	NBL, Outside	174+00	185+00	177+50, 179+69±, 181+00
-L-	NBL, Median	202+00	210+00	205+82± (2GI)
-L-	NBL, Outside	227+50	235+00	230+50, 232+33±

-L-	NBL, Median	227+50	235+00	231+00 (JB), 232+42± (2GI)
-L-	NBL, Outside	238+00	244+50	241+47 (2GI), 244+50 (2GI)
-L-	NBL, Median	245+45	249+70	245+45 (2GI)
-L-	NBL, Outside	282+00	292+00	285+00 (2GI), 286+89±, 288+30
-L-	NBL, Outside	310+00	320+30	313+00, 315+20±, 317+00
-L-	NBL, Median	311+50	319+00	315+05± (2GI)
-L-	NBL, Outside	338+00	356+00	341+50, 344+02±, 348+50, 352+30 (2GI)
-L-	NBL, Outside	369+00	384+00	373+16±, 375+00, 378+00, 381+00
-L-	NBL, Median	369+00	379+00	373+40± (2GI), 375+80 (2GI)
-L-	NBL, Outside	430+00	443+60	433+00, 436+20 (2GI), 439+50, 443+60
-L-	NBL, Outside	450+00	455+50	450+00, 452+50
-L-	NBL, Median	449+50	455+50	449+50 (2GI), 451+80 (2GI)
-L-	NBL, Outside	545+50	554+40	549+30 (2GI), 551+81± (2GI)
-L-	NBL, Median	545+50	556+00	549+30 (2GI), 551+81± (2GI)
-L-	SBL, Median	114+45	119+85	116+60± (2GI)
-L-	SBL, Outside	120+50	124+86	120+50 (2GI)
-L-	SBL, Outside	124+86	128+25	128+25 (2GI)
-L-	SBL, Outside	223+00	236+50	226+00, 229+00 (2GI), 232+42±, 234+00 (2GI)
-L-	SBL, Median	226+00	236+50	229+25 (2GI), 232+42± (2GI), 234+00 (2GI)
-L-	SBL, Median	241+00	244+67	244+67 (2GI)
-L-	SBL, Outside	245+00	248+50	245+00 (2GI)
-L-	SBL, Outside	310+00	321+00	313+00, 315+06±, 317+50
-L-	SBL, Median	312+00	319+00	315+05± (2GI)
-L-	SBL, Outside	528+00	536+70	531+50 (2GI), 534+50, 536+70 (2GI)
-L-	SBL, Median	528+00	536+70	531+50 (2GI), 534+05 (2GI), 536+70 (2GI)
-L-	SBL, Outside	546+00	556+50	549+30 (2GI), 551+81± (2GI), 553+50
-L-	SBL, Median	546+00	554+40	549+30 (2GI), 551+81± (2GI)
-L-	SBL, Outside	559+00	568+80	562+50, 564+84±, 566+50
-L-	SBL, Median	566+35	569+80	566+35 (2GI)

Note: The locations of sag vertical curves are noted with a Station ± in the table above. At these locations, as well as at any other proposed sag vertical curves, the Design-Build Team shall provide two outlets. (Ex. 564+84±)

HYDRAULICS SCOPE OF WORK (2-20-06)

- The Design-Build Team shall develop all drainage designs in accordance with criteria provided in the North Carolina Division of Highways “*Guidelines for Drainage Studies and Hydraulics Design-1999*” and the addendum “*Handbook of Design for Highway Drainage Studies-1973*” and the NCDOT Hydraulic Unit Website.
- With respect to stormwater management, sediment and erosion control, and riparian buffers, the Design-Build Team shall incorporate into the design and construction the requirements for WS-IV and WE-V Waters as specified in 15A NCAC 2B .0216 (WS-IV), .0217 (Stormwater Control Criteria), and .0218 (WS-V) for the entire project length.
- Due to crossings of water supply watershed waters and the presence of 303(d)-listed streams, the Design-Build Team shall incorporate *Design Standards in Sensitive Watersheds* into the design and construction.
- The minimum allowable ditch grade shall be 0.3%.
- Ditches shall not be allowed in wetlands.
- Sag vertical curves shall not be allowed on bridges or bridge approaches.

The following items shall be required of the Design-Build Team:

- Storm drainage design and installation
- Bridge Survey Report for all bridges
- Culvert Survey Report for all culverts providing conveyance greater than a 72” pipe
- The Design-Build Team shall remove and dispose of all existing box culverts. The Design-Build Team shall design and install new structures at the existing box culvert locations, providing a bottomless structure at Wicker Branch.
- Hazardous Spill Basins shall be provided for two unnamed tributaries of Buck Branch, located north and south of McRorie Road (SR 1952)
 - A hazardous spill basin shall be located at the north end of the Lanes Creek Bridge
- Stormwater Management Plan
- The Department has obtained a US Army Corps of Engineers Section 404 Permit and a NC Department of Natural resources (DENR), Division of Water Quality (DWQ) Section 401 Water Quality Certification. Any variations in the Department’s proposed design and / or construction methods that require a permit modification shall be the sole responsibility of the Design-Build Team. As a minimum, the Design-Build Team shall be

responsible for preparing all designs and documents, including but not limited to permit impact sheets, required to obtain a permit modification.

- In the Technical Proposal, the Design-Build Team shall address Pre and Post Analysis methodology for increases in discharge. The Design-Build Team shall be responsible for taking the appropriate action, in accordance with the above referenced guidelines, to make sure additional drainage is adequately handled.
- Coordination of final hydraulic design with FEMA and Union County. If applicable, the Design-Build Team shall ensure compliance with floodplain ordinances

GEOTECHNICAL ENGINEERING UNIT SCOPE OF WORK (2-21-06)**I. GENERAL:**

Obtain the services of a firm prequalified for geotechnical work from the Highway Design Branch List. The prequalified geotechnical firm shall prepare foundation design recommendation reports for use in designing structure foundations, roadway foundations, retaining walls, sound barrier foundations and temporary structures. The prequalified geotechnical firm shall also determine if additional subsurface information, other than that required and noted elsewhere in this RFP, is required based upon the subsurface information provided by NCDOT and the final roadway and structure designs. If a determination is made that additional subsurface information is required, the Design-Build Team shall perform all additional subsurface investigation and laboratory testing in accordance with the current NCDOT *Geotechnical Unit Guidelines and Procedure Manual*.

A minimum of 2 standard penetration test (SPT) / rock core borings shall be required per bent for all bridges except dual bridges. A minimum of 3 SPT / rock core borings total shall be required across both bents for dual bridges. All borings shall be deep enough to show a complete soil and rock profile to the depth of the foundation supporting layer. These borings are required on all bents where subsurface information is not sufficient. The Design-Build Team shall present any proposed deviation from these requirements in the Technical Proposal. The NCDOT Geotechnical Engineering Unit will review the proposed deviations and determine if they are acceptable.

The maximum spacing between borings for retaining walls shall be 200 feet, with a minimum of two borings; one at each end of the wall. Drill borings for retaining walls to twice the maximum height of the wall.

II. DESCRIPTION OF WORK:

The Design-Build Team shall design foundations, embankments, slopes, retaining walls, sound barrier foundations and temporary structures in accordance with the current allowable strength design AASHTO *Standard Specifications for Highway Bridges*, NCDOT *Structure Design Manual*, NCDOT *Roadway Design Manual* and the Geotechnical Engineering Unit *Roadway and Structure Foundation Guidelines*.

A. Structure Foundations

The Design-Build Team shall design foundations with concrete footings, prestressed concrete piles, steel piles or drilled piers. Steel reinforcement shall be required for concrete foundations. Design spread footings with the bottom of footing elevation at or below the weathered rock or hard rock elevation. Key in spread footings of structures crossing streams a minimum of full depth below the 100-year design scour elevation and provide scour protection in accordance with scour protection detail in *the NCDOT Structure Design Manual*.

Piles shall have at least 10 feet of embedment below the lowest of the following: 100-year design scour elevation, bottom of footing elevation, finished or existing

grade elevation. Obtain approval from the NCDOT Hydraulics Unit for any longitudinally battered piles for pile bents of structures crossing streams or wetlands. Permanent steel casings shall be required for drilled piers that are constructed in six inches or more of water. Permanent casings may be required where drilled piers are constructed on stream banks.

When the weathered rock or rock elevation is below the 100-year hydraulic scour elevation, the 100-year and 500-year design scour elevations are equal to the 100-year and 500-year hydraulic scour elevations from the structure survey report approved by the NCDOT Hydraulics Unit. When the weathered rock or rock elevation is above the 100-year hydraulic scour elevation, the 100-year design scour elevation may be considered equal to the top of the weathered rock or rock elevation, whichever is higher, and the 500-year design scour elevation may be set two feet below the 100-year design scour elevation.

End bent fill slopes up to 35 feet in height (defined as the difference between grade point elevation and finished grade at toe of slope) shall be 1.5:1 (H:V) or flatter. End bent slopes with heights greater than 35 feet or end bent cut slopes shall be 2:1 or flatter.

End bent slope protection for fill slopes 2:1 (H:V) or flatter and all cut slopes shall extend from the toe of slope to the limits of the superstructure. End bent slope protection for fill slopes steeper than 2:1 (H:V) shall extend from the toe of slope to berm.

Design foundations for service loads using allowable stress design. The ultimate bearing capacity of all piles shall be determined by "Method B - Wave Equation Analysis" outlined in Division II, Section 4.4 of the current allowable stress design AASHTO *Standard Specifications for Highway Bridges*.

Analyze drilled pier and pile bent foundations using either Lpile or FB-Pier. Drilled piers and vertical piles shall be "fixed" in the soil / rock such that a decrease in pier or pile length shall not significantly increase the top deflection. The Design-Build Team's structural engineer shall submit correspondence to the Department approving all deflections greater than 1 inch in the free head condition for either top of pile for a pile bent or top of column for post and beam construction on drilled piers.

B. Roadway Foundations

Design all unreinforced fill slopes for a slope of 2:1 (H:V) or flatter except bridge end bent slopes (see Section A) and a minimum stability factor of safety of 1.3. Design all cut slopes for a slope of 2:1 (H:V) or flatter and a minimum stability factor of safety of 1.5. Use limiting equilibrium methods, such as Modified Bishop, Simplified Janbu, Spencer or any other generally accepted method for slope stability analysis.

Design sound barrier foundations in accordance with current allowable stress design AASHTO *Guide Specifications for Structural Design of Sound Barriers*. A minimum factor of safety of 1.5 shall be required for shaft embedment depths.

Embankment settlement monitoring in accordance with the Embankment Monitoring Special Provision shall be required when a waiting period of more than one month is recommended in the foundation design recommendation reports. Two settlement plates or other types of embankment settlement monitoring devices shall be required at each location. Settlement monitoring device locations shall be no more than 200 feet apart or at each bridge end bent location, whichever is closer. Settlement gauges, surveyed stakes on finished subgrade or other methods may be used instead of settlement plates, but alternatives shall be submitted to the NCDOT Geotechnical Engineering Unit for review prior to installation.

Reinforced bridge approach fills in accordance with the NCDOT standard shall be required for end bents on all bridges.

C. Permanent Retaining Wall Structures

Extensible reinforcement shall not be allowed for any permanent retaining walls. Modular block walls shall not be allowed for critical wall structures. Critical wall structures include walls supporting or adjacent to interstate highways, bridge abutments, wing walls and walls over 18 feet in height.

The following list of retaining wall types are acceptable for consideration for permanent applications:

- Gravity wall
- Cast-in-place cantilever wall
- Modular block wall
- Mechanically stabilized earth (MSE) wall
- Soldier pile cantilever wall with either a cast-in-place face or precast panels
- Anchored tieback wall
- Soil nail wall

Design and construct permanent retaining walls, with the exception of gravity walls and cast-in-place cantilever walls, in accordance with the applicable NCDOT *Project Special Provisions*. For each retaining wall, with the exception of gravity walls, submit a wall layout and design. The wall layout submittal shall include the following:

- Wall envelope with top of wall, bottom of wall, existing ground and finished grade elevations at incremental stations.
- Wall alignment with stations and offsets.
- Typical sections showing top and bottom of wall, drainage, embedment, slopes, barriers, fences, etc.
- Calculations for bearing capacity, global stability and settlement.

- Details of conflicts with utilities and drainage structures.
- Roadway plan sheets showing the wall (half size).
- Roadway cross sections showing the wall (half size).
- Traffic control plans showing the wall (half size).

Gravity walls shall be designed and constructed in accordance with the NCDOT Roadway Standard Drawings and the NCDOT 2002 *Standard Specifications*. Gravity walls do not require any submittals and shall be identified in the roadway foundation design recommendation report. Cast-in-place cantilever walls shall be designed and constructed in accordance with the NCDOT 2002 *Standard Specifications*.

Locate retaining walls at toe of slopes unless restricted by right of way limits. Any slopes behind walls are required to be 2:1 (H:V) or flatter. Embed retaining walls in accordance with FHWA Manual *Demonstration Project 82 Reinforced Soil Structures MSEW and RSS* or a minimum of two feet, whichever is greater. The wall embedment depth is from the grade that intersects the front of the wall (either finished grade or natural ground elevation) or 100 year scour elevation, whichever is lower, to the top of the leveling pad.

Drainage over the top of retaining walls shall not be allowed. Sags in the top of walls shall be avoided. Direct runoff above and below walls away from walls, if possible, or collect runoff at the walls and transmit it away. Curb and gutter or cast-in-place single faced barrier with paving up to the wall shall be required when runoff can not be directed away from the back or front of the wall. A paved concrete ditch with a minimum depth of six inches shall be required at the top of walls when slopes steeper than 6:1 (H:V) intersect the back of walls.

Precast or cast-in-place coping is required for walls without a cast-in-place face with the exception of when a barrier is integrated into the top of the wall. Extend coping or cast-in-place face a minimum of six inches above where the finished or existing grade intersects the back of the wall. Design concrete barriers integrated into retaining walls for traffic impact in accordance with AASHTO. A fence shall be required on top of the facing, coping or barrier or immediately behind the wall, if there is no slope behind the wall.

Design end bents with abutment retaining walls for deep foundations only. Wing walls independent of abutment retaining walls shall be required unless approved otherwise by the NCDOT. When using abutment retaining walls, design and construct the end bent and the wall independent of each other. When using piles and abutment retaining walls, the end bent foundation must include brace piles battered toward the wall, or be supported on either a single row of plumb piles with MSE reinforcement strapped to the back of the cap, or on a double row of plumb piles or drilled piers. Do not consider lateral support from any fill placed around drilled piers behind abutment retaining walls when analyzing end bent stability. All deep foundations for end bents with abutment retaining walls shall penetrate ten feet into natural ground. If fill is required around piles or drilled piers, install foundations before placing any fill.

D. Temporary Structures

Design temporary retaining structures, which include earth retaining structures and cofferdams, in accordance with Section 4 of the 1995 or current allowable stress design AASHTO *Guide Design Specifications for Bridge Temporary Works* and the NCDOT Temporary Shoring for Maintenance of Traffic Special Provision. The only submittal required to use the standard sheeting design is the “Standard Shoring Selection Form”.

Design and construct temporary retaining walls in accordance with the applicable NCDOT *Project Special Provision*. For temporary retaining walls, do not place a barrier within five feet of the face of the wall. If the barrier is between five and nine feet from the face of the wall, anchor the barrier in accordance with Roadway Standard Detail No. 11.70.01.

III. CONSTRUCTION REQUIREMENTS:

All construction and materials shall be in accordance with the NCDOT 2002 *Standard Specifications* and current NCDOT *Project Special Provisions*. The Design-Build Team shall be responsible for investigating, proposing and incorporating remedial measures for any construction problems related to foundations, retaining walls, subgrades, settlement, slopes, and construction vibrations. The NCDOT Geotechnical Engineering Unit shall review and approve these proposals.

The Design-Build Team shall be responsible for any damage or claim caused by construction, including damage caused by vibration (see Article 107-15 *NCDOT Standard Specifications for Roads and Structures*). The Design-Build Team shall be responsible for deciding what, if any, pre and post-construction monitoring and inventories need to be conducted to satisfy their liability concerns. Any monitoring and inventory work shall be performed by a qualified private engineering firm experienced in the effects of construction on existing structures.

The prequalified geotechnical firm that did the foundation designs must review the embankment monitoring data and issue a letter prior to releasing the embankment from the waiting period. The NCDOT Geotechnical Engineering Unit will review the release letter and data.

The prequalified geotechnical firm that did the foundation designs shall review and approve all pile driving hammers and drilled pier construction sequences. The NCDOT Geotechnical Engineering Unit shall review these approvals.

Perform hammer approvals with GRLWEAP Version 2002 or later and in accordance with the latest edition of the *NCDOT 2002 Standard Specifications*. Provide pile driving inspection charts or tables for all approved pile hammers. A minimum of 30 blows per foot shall be required to verify the design bearing capacity with a minimum factor of safety of two. Stresses during driving may not exceed the limits outlined in the FHWA manual “*Design and Construction of Driven Pile Foundations*”. If prestressed concrete

piles are used, test a minimum of one prestressed concrete pile for each bridge for bearing and stresses with a pile driving analyzer (PDA).

Use current NCDOT inspection forms for drilled piers available on the Geotechnical Engineering Unit's webpage (www.ncdot.org/doh/preconstruct/highway/geotech/). The Design-Build Team shall use the Shaft Inspection Device (SID) in accordance with the Drilled Piers Special Provision to inspect the first drilled pier excavation that is not hand cleaned for each bridge location. Install Crosshole Sonic Logging (CSL) tubes in all drilled piers. CSL testing may be required for up to a third of the drilled piers for each bridge. The NCDOT shall determine which piers will be CSL tested. The NCDOT Geotechnical Engineering Unit shall determine if the CSL results are acceptable.

Verify bearing on rock for spread footings in the field during construction.

Provide field quality control for all bridge foundations including pile driving records and drilled pier inspection forms. Provide field quality control for all retaining wall and sound barrier foundations including verifying subsurface conditions for drilled piers and bearing for shallow foundations.

The prequalified geotechnical firm that did the original design shall perform any changes to the foundation designs. All changes shall be based upon additional information, subsurface investigation and / or testing. Drilled pier tip elevations shall not be changed during construction unless the prequalified geotechnical firm that did the bridge foundation design redesigns the drilled pier from an SPT / rock core boring in accordance with ASTM standards at the subject pier location or observations of the drilled pier excavation. If a drilled pier is designed based on a boring, do not drill a boring inside an open drilled pier excavation. Locate the boring within three pier diameters of the center of the subject pier and drill to a depth of two pier diameters below the revised tip elevation. If a drilled pier is redesigned based upon observations of the drilled pier excavation, the geotechnical engineer of record shall be present during the excavation to determine the actual subsurface conditions. Send copies of revised designs including additional subsurface information, calculations and any other supporting documentation sealed by a professional engineer registered in the State of North Carolina to the State Alternative Delivery Systems Engineer for review by the NCDOT Geotechnical Engineering Unit. Also, send copies of any inspection forms related to foundations, settlement or retaining walls to the State Alternative Delivery Systems Engineer for review by the Geotechnical Engineering Unit.

ROADWAY AND STRUCTURE FOUNDATION GUIDELINES

The Design-Build Team shall be responsible for (but not limited to) addressing, and incorporating if necessary, the following items for the roadway and structure foundation design of the project.

1. Analyze the stability of embankments and utilize recognized geotechnical engineering designs and construction methods approved by NCDOT to ensure embankment stability.
2. Analyze embankment settlement and if necessary, recommend and incorporate mitigation through the use of undercut or soil improvement methods such as surcharges, waiting periods, wick drains, etc.

3. Address, and incorporate if needed, the following regarding embankment problems:
 - a. The feasibility of using geo-textiles to achieve stability, reduce excavation of soft soils and reduce the effect of settlement on the roadway.
 - b. The need for settlement gages, slope inclinometers and other embankment monitoring devices and their placement and location.
4. Determine the feasibility, recommend and incorporate types of retaining walls and / or shoring for permanent and / or temporary situations. Design all retaining walls in accordance with the current allowable stress design AASHTO *Standard Specifications for Highway Bridges* and applicable FHWA manuals.
5. Determine amount of, recommend and incorporate methods to mitigate any differential settlement problems at locations of culverts and utilities.
6. Analyze the stability of cut sections. Utilize recognized geotechnical engineering designs and construction methods to ensure cut slope stability.
7. Analyze the stability of roadway approaches (to the distance from the bridge that affects the stability and design of the bridge foundations) and particularly the end slopes under the bridge, utilizing recognized geotechnical engineering designs and construction methods to ensure stability.
8. Recommend pile, drilled pier or spread footing foundations for structures with regard to bearing capacity, lateral stability, buckling analysis for piles, scour, settlement and constructability. Use the 100-year design scour elevation for foundation design.
9. Recommend allowable bearing pressure for spread footings considering settlement, adjacent foundations, water table, scour, etc. The scour critical elevation for a spread footing shall be at the bottom of footing elevation.
10. Address the following regarding pile and / or drilled pier foundations:
 - a. Method of support – skin friction, tip bearing or combination of both.
 - b. Tip elevations no higher than and estimated pile lengths.
 - c. Allowable axial load.
 - d. Settlement.
 - e. Number and location of test piles or piers and dynamic and/or static load testing.
 - f. Wave equation analysis using an appropriately chosen pile hammer and cushion material for each bent.
 - g. Necessity of using steel pile tips for concrete piles or pile points for steel piles.
 - h. Effects of vibration on adjacent construction or existing structures.
 - i. Corrosion effects of various soils and water (See Structure Design Unit's Policy Manual).
 - j. Downdrag on piles or piers.
 - k. Lateral stability and allowable horizontal deflections.
 - l. Design scour and scour critical elevations. The scour critical elevation for a drilled pier foundation shall be the 500-year design scour elevation. The

scour critical elevation for a pile foundation shall be when the scour reaches an elevation that results in a factor of safety equal to 1.

- m. Point of fixity or point of rotation.
- n. Lateral squeeze for piles.

11. Include in the geotechnical recommendations report a summary table of the bridge foundation recommendations including the following:

- a. State project number, TIP number, county, description and bridge station.
- b. Bent (work point) stations, types of foundations, allowable loads, bottom of cap or footing elevations, estimated pile lengths and tip elevations.

12. Address the following items, when applicable, as notes on plans or comments and attach to the summary table:

- a. All appropriate notes on plans (See Structure Design Unit's Standard Foundation Notes on Plans).
- b. End slope and extent of slope protection.
- c. Waiting periods for approach slab construction or end bent construction.
- d. Battered piles.
- e. Point of fixity or point of rotation elevations.
- f. Design and scour critical elevations.
- g. Tip elevations no higher than.
- h. Steel pile points for steel piles or steel pile tips for concrete piles.
- i. Number and location of test piles or piers, load tests, dynamic and/or static testing.
- j. Required rock socket for drilled piers.
- k. Need for permanent steel casing including casing tip elevations, SPT, SID Inspection, CSL and slurry use in accordance with the Drilled Piers Special Provision.
- l. Range of allowable hammer energies for concrete and pipe piles.

Address any other items affecting the foundation design on the summary sheets and include all final recommendations on the summary sheets.

The Design-Build Team shall adhere to the latest design guide entitled *Soils and Foundations Workshop Manual*, NHI Course No. 13212, Publication No. FHWA HI-88-009, published by the FHWA.

CEMENT AND LIME STABILIZATION OF SUBGRADE SOILS SCOPE OF WORK

GENERAL

The Cement and Lime Stabilization of Subgrade Soils Scope of Work shall consist of the following:

1. Sampling Subgrade soils
2. Conducting Laboratory tests to determine:
 - a. Soil classifications
 - b. Moisture-density Characteristics
 - c. Quantity of lime or cement required to achieve specified strengths
3. Designating areas to be stabilized by either lime or cement and the required rates of application.
4. Conducting field tests to determine unconfined compressive strength

SAMPLING

The Design-Build Team shall take soil samples, after the project has been graded to within 2 inches of final subgrade elevation. The Design-Build Team shall sample the top 8 inches at a minimum frequency of one sample per 985 feet, per each lane, for classification tests and one sample per 3280 feet, per each lane, for moisture density tests and lime or cement mix design tests in each lane. Additional samples shall be taken to ensure that all the predominant soil types, limits of distribution of these soils and different site conditions have been represented.

CLASSIFICATION TESTS

The Design-Build Team shall perform the following tests to determine AASHTO classifications of different soils in accordance with AASHTO specifications as modified by NCDOT. Copies of these modified procedures can be obtained from the NCDOT Materials and Test Unit's Soil Sub-unit.

TABLE 1

<u>TEST</u>	<u>AASHTO DESIGNATION</u>
Dry Preparation of Disturbed Soils	T-87
Particle Size Analysis of Soils	T-88
Determining the Liquid Limit of Soils	T-89
Determining the Plastic Limit and Plasticity Index of Soils	T-90

MOISTURE DENSITY TEST

Based on the criteria shown in Table 2, below, the Design-Build Team shall perform the Moisture Density Tests, using either lime or cement. The Design-Build Team shall use 10% cement by weight in soil cement and 4% lime by weight, in soil-lime mixtures. The Design-Build Team shall conduct the tests in accordance with AASHTO T-99, and T-134 for soil-lime and soil-cement mixtures, respectively. In each case, the Design-Build Team shall determine the maximum dry density and optimum moisture content.

TABLE 2

<u>CRITERIA FOR SELECTING LIME OR CEMENT</u>		
PROPERTY	A	B
Percent passing #200 Sieve	35 Max	36 Min
Liquid Limit	40 Max	41 Min
Plasticity Index	10 Max	25 Min

The Design-Build Team shall use cement for all soils meeting criteria in Column A and Lime for all soils meeting criteria in Column B. The Design-Build Team may choose either lime or cement for all soils not meeting all criteria in either Column A or B.

DETERMINING THE APPLICATION RATES FOR SOIL-CEMENT AND SOIL-LIME MIXTURES

SOIL-CEMENT MIXTURES

For Soil-Cement Mixtures, the Design-Build Team shall be required to do the following:

- Make specimens at optimum moisture content using a quantity of cement in the range of 5 to 12 percent by weight.
- Compact the specimens to a minimum density of 95% of maximum Dry Density obtained using AASHTO T 134.
- Make a minimum of 2 specimens for each selected cement rate.

- Cure the specimens for 7 days in a moist room maintained at a temperature of 73°F $\pm 2.7^\circ$ (23°C $\pm 1.5^\circ$) and a humidity of 100%. At the end of curing period, immerse the specimens in water for 4 hours. After immersion, test the specimens using the unconfined Compressive Strength Test (AASHTO T 208 Section 7).
- Report the maximum strength obtained and the percent strain corresponding to it.
- Select the rate of cement that provides a minimum unconfined Compressive Strength of 200 PSI (1400 KPA) and a maximum of 350 PSI (2400 KPA).

SOIL-LIME MIXTURES

For Soil-Lime Mixtures, the Design-Build Team shall be required to follow the Department's Soil-Lime Mixtures procedure with the following exceptions:

- The quantity of lime required shall be in the range of 3.5 to 6.5 percent by weight.
- Compact specimens to a minimum density of 95% of maximum dry density obtained by AASHTO T99.
- Do not immerse the specimens in water at the end of the curing period.
- Select the rate of lime that provides a minimum unconfined compressive strength of 58 PSI (400 KPA).

SUBMITTALS FOR REVIEW AND APPROVAL PRIOR TO CONSTRUCTION

The Design-Build Team shall adhere to the following submittal guidelines:

- Submit all laboratory test results for review.
- Submit a sketch in plan view showing areas of the project to be stabilized by either lime or cement and application rates for each stabilizer.
- Submit any other documentation that supports the Design-Build Team's recommendations.

CONSTRUCTION OF LIME TREATED SUBGRADE

The Design-Build Team shall construct the lime treated subgrade as specified in Section 501 of the North Carolina Department of Transportation *Standard Specifications for Roads and Structures* with the following exceptions:

Subsection 501-4 Equipment

Contractor's equipment will not require engineer's approval.

Subsection 501-8 (A) General

Paragraph #1 is not applicable to this project.

Subsection 501-9 (B) Preliminary Curing

Amend as follows: Allow a minimum of 2 days and a maximum of 4 days for preliminary curing.

Subsection 501-10 Compacting, Shaping, and Finishing

Last paragraph is not applicable.

Subsection 501-11 Thickness

Last two paragraphs are not applicable.

Subsection 501-15 Method of Measurement

The entire sub-sections are not applicable.

Subsection 501-16 Basis of Payment

The entire sub-section is not applicable.

CONSTRUCTION OF CEMENT TREATED SUBGRADE

The Design-Build Team shall construct the soil cement subgrade as specified in section 542 of the North Carolina Department of Transportation *Standard Specifications for Roads and Structures*, with the following exceptions:

Subsection 542-4 Equipment

Contractor's equipment will not require Engineer's approval.

Subsection 542-7 Application of Cement

First paragraph is not applicable.

Subsection 542-11 Thickness

Paragraphs 2 and 3 are not applicable.

Subsection 542-16 Method of Measurement

This entire sub-section is not applicable.

Subsection 542-17 Basis of Payment

This entire sub-section is not applicable.

UNCONFINED COMPRESSIVE STRENGTH

The Design-Build Team shall allow a minimum of seven days curing before testing for strength. The lime stabilized subgrades shall be tested using Dynamic Cone Penetrometer. A sketch of the design of this equipment and testing procedures can be obtained from the NCDOT Geotechnical Unit. The required unconfined compressive strength for lime shall be 58 PSI (400 KPA). For Cement stabilized subgrades, the Design-Build Team shall make field specimens, cure them for seven days and test them in the laboratory. The required unconfined compressive strength for soil cement shall be 200 PSI (1400 KPA). In both cases, one test shall be required for every 443 feet per 12.5 feet lane, at random locations selected using random number tables.

SUBMITTALS FOR REVIEW DURING CONSTRUCTION

The Design-Build Team shall submit the unconfined compressive strength test results for review.

ENVIRONMENTAL PERMITS SCOPE OF WORK (2/23/2006)**General**

The Department will allow no direct contact between the Design-Build Team and representatives of the environmental agencies. Moreover, no contact between the Design-Build Team and the environmental agencies will be allowed either by phone, e-mail or in person, without representatives of the Department's PDEA Branch and / or the Division's Environmental Officer present. A representative from Alternative Delivery Systems shall be included on all correspondence.

The Department will obtain the US Army Corps of Engineers Individual Section 404 Permit and the NC Department of Natural Resources, Division of Water Quality (DWQ) Section 401 Individual Water Quality Certification. If modifications to permits for this project are determined necessary, the Design-Build Team shall be responsible for preparing all documents required for the Department to obtain permit modifications. The Design-Build Team shall not begin ground-disturbing activities in jurisdictional areas impacted by design and / or construction revisions, including utility relocations, until the required environmental permit modifications have been issued (this does not include permitted investigative borings covered under a Nationwide Permit No. 6).

The Department has completed the Merger 01 Process used by the environmental agencies and the Department to obtain environmental permits for highway projects. Any variations in the Department's proposed design and / or construction methods that nullify any Concurrence Points and / or require additional coordination with the Environmental Agencies shall be the sole responsibility of the Design-Build Team. The Department shall not allow any contract time extensions associated with this additional coordination.

The Design-Build Team shall be bound by the terms of all signed planning documents and approved minutes and commitments of all concurrence meetings and shall be held accountable for meeting all permit conditions. The Design-Build Team shall be required to staff any personnel necessary to provide permit compliance.

Permit Modification Process

The NCDOT will acquire the permits for this project based on the plans developed by the Department. This section, as well as the Permit Modification Timeframe section, applies only in the event that the design and / or construction proposed by the Design-Build Team necessitates a permit modification. The Design-Build Team shall clearly note in the Technical Proposal proposed changes requiring a permit modification.

Requests made for modifications to the permits obtained by the Department shall only be allowed if the NCDOT determines it to be in the Department's best interest and will be strongly discouraged. The Design-Build Team shall not take an iterative approach to hydraulic design issues. The hydraulic design shall be complete prior to submitting the permit modification application.

The Design-Build Team shall submit one permit modification application for the entire project. The Design-Build Team shall not submit multiple applications to develop a "staged permitting" process to expedite construction activities in a phased fashion.

Should the Design-Build Team's design and / or construction methods, including revised utility relocations, require a permit modification, the Design-Build Team shall be responsible for acquiring information and preparing permit drawings that reflect the impacts and minimization efforts resulting from the Merger 01 Process and as designed by the Design-Build Team. Further, the Design-Build Team shall be responsible for developing and providing the permit impact sheets (drawings) depicting the design and construction details to the Department as part of any permit modification application. The Design-Build Team shall be responsible for developing all permit modification applications resulting from changes in jurisdictional impacts. The permit modification application shall consist of, at a minimum, the following:

- Cover Letter
- Permit drawings
- Half-size plans
- Completed forms (ENG 4345, Section 404, etc.) appropriate for impacts
- EEP acceptance letter, if necessary

The Design-Build Team shall re-verify and update, as needed, the required environmental data that expires prior to the completion of the activity causing the impact in the jurisdictional areas. These include, but are not limited to, federally protected species, re-verification of wetland jurisdictional areas, historic and archaeological sites, and 303d (impaired) streams. The Design-Build Team shall draft a letter, for the Project Development and Environmental Analysis Branch's (PDEA) signature, requesting concurrence from the United States Fish and Wildlife Service to document compliance with Section 7 of the Endangered Species Act for those species requiring such concurrence. The original dates of verification / concurrence are listed below:

- Dates of verification for wetlands and streams (December 17, 2002)
- USFWS concurrence on species (April 1, 2004)

Direct coordination between the Design-Build Team, the Department's Alternative Delivery Systems Engineer, Resident Engineer, Division Environmental Officer and the Natural Environment Unit (PDEA-NEU) shall be necessary to ensure proper development of the permit modification application. Upon completion of the permit modification application package, the Design-Build Team shall forward the package to the Alternative Delivery Systems Engineer, Resident Engineer, Division Environmental Officer and PDEA-NEU concurrently, for review and approval. The Department will subsequently forward the package to the appropriate agencies to have the permit modification application placed on public notice to reflect the details.

Any temporary construction measures, including de-watering, construction access, etc. shall be addressed in the permit modification application. Impacts that result from so-called temporary measures may not be judged to be temporary impacts by the resource agencies.

The Design-Build Team shall clearly indicate the location of and impacts of haul roads and utility relocations on jurisdictional areas. The Design-Build Team shall also identify all proposed borrow and waste sites. These details shall be included in the permit modification application data. Further, the Design-Build Team shall describe the methods of construction of all structures. The description of the temporary impacts on jurisdictional resources (haul roads, utility relocations, work bridges, etc.) shall include restoration plans, schedules, and disposal plans. This information shall be included in the permit modification application.

The NCDOT hereby commits to ensuring, to the greatest extent possible, that the footprint of the impacts in areas under the jurisdiction of the federal Clean Water Act shall not be increased during the Design-Build effort. All fill material shall be immediately stabilized and maintained to prevent sediment from entering adjacent waters or wetlands. The Design-Build Team shall be responsible for ensuring that the design and construction of the project will not impair the movement of aquatic life.

Permit Modification Timeframe

The Design-Build Team should expect the environmental agency review time for a permit modification to be approximately 60 days from receipt of a “complete” package. No requests for additional contract time or compensation shall be allowed for obtaining a permit modification. With the exception of location and survey work and permitted investigative borings covered under a Nationwide Permit No. 6, no mobilization of men, materials, or equipment for site investigation or construction of the project shall occur in jurisdictional areas impacted by design and / or construction revisions prior to obtaining the required permit modification. This limitation does not preclude the off-site fabrication of bridge members or equipment. The Department shall not honor any requests for additional contract time or compensation, including idle equipment or mobilization or demobilization costs, for the Design-Build Team mobilizing men, materials (or ordering materials), or equipment prior to obtaining a permit modification. The Department shall consider requests for contract time extensions for obtaining a permit modification only if the Design-Build Team has pursued the work with due diligence and the delay is beyond their control.

The Design-Build Team needs to be aware that the timeframe listed above for review by NCDWQ and the US Army Corps of Engineers begins only after a complete and accurate submittal.

Mitigation Responsibilities of the Design-Build Team

The N.C. Ecosystem Enhancement Program has agreed to provide compensatory mitigation for unavoidable impacts to wetlands and surface waters resulting from the project construction. The mitigation was based on the impacts identified in the planning process and will be available Spring 2006. The Design-Build Team shall not begin ground-disturbing activities, including utility relocation, until the mitigation is available.

Any changes proposed by the Design-Build Team, to any design or construction details provided by the Department, shall be approved by the Department prior to being submitted to the resource agencies for their approval.

Should additional jurisdictional impacts result from design and / or construction details revised by the Design-Build Team, suitable compensatory mitigation for wetlands and / or streams shall be the sole responsibility of the Design-Build Team. Therefore, it is important to note that additional mitigation shall require approval by the agencies; and such approval shall require, at a minimum, the Design-Build Team to prepare and obtain approval of a mitigation plan before a permit modification is approved and before construction shall commence in the impacted jurisdictional areas.

The Design-Build Team shall analyze any new areas to be impacted that were not analyzed during the NEPA process and / or preparation of the permit application. This analysis shall

include performing all environmental assessments. These assessments shall require the Design-Build Team to engage the services of a competent environmental consultant to conduct a full environmental investigation to include, but not be limited to, Federally Listed Threatened and Endangered Species, wetlands, streams, avoidance and minimization in jurisdictional areas, compensatory mitigation, FEMA compliance, historical, archaeological, and cultural resources surveys in these areas. The environmental consultant shall obtain concurrence through PDEA-NEU from the United States Fish and Wildlife Service to document compliance with Section 7 of the *Endangered Species Act* for those species requiring such concurrence. In addition, the Design-Build Team shall identify and be responsible for all additional mitigation required; identify the amount of time the modification will take; and fulfill any other requirements that may be imposed by the permitting agencies to obtain the permit modification. Any contract extensions resulting from additional environmental assessments required by the Design-Build Team's design and / or construction details impacting areas outside those previously analyzed through the NEPA Process shall be solely at the discretion of the Department.

If any staging areas are located outside the project's right-of-way, the Design-Build Team shall engage the services of a competent environmental consultant to conduct a full environmental investigation to include, but not be limited to, Federally Listed Threatened and Endangered Species, wetlands, streams, avoidance and minimization in jurisdictional areas, compensatory mitigation, historical, archaeological, and cultural resources surveys in these areas.

If the Design-Build Team discovers any previously unknown historic or archeological remains while accomplishing the authorized work, they shall immediately notify NCDOT Staff Archaeologist and / or NCDOT Project Development Engineer, as listed below, who will initiate the required State / Federal coordination. A representative from Alternative Delivery Systems shall also be notified. All questions regarding these sites shall be addressed to Mr. Matthew Wilkerson, NCDOT Archaeology (919) 715-1561, or Mr. Mark Pierce, PE, NCDOT Project Development Engineer (919) 733-7844, ext. 214.

Commitments

The NCDOT is committed to incorporating all reasonable and practicable design features to avoid and minimize wetland impacts and to provide full compensatory mitigation of all remaining wetland impacts. Avoidance measures were taken during the planning and NEPA phases and minimization measures were incorporated as part of the preliminary project design.

All work by the Design-Build Team shall be accomplished in strict compliance with the plans submitted with the Section 404, and 401 permit applications and in compliance with all conditions of the permits and certifications issued by the agencies. The Design-Build Team shall provide each of its contractors and / or agents associated with the construction or maintenance of this project with a copy of the permits.

The Design-Build Team shall strictly adhere to these commitments, as well as others, including but not limited to, those made as part of the EA, FONSI, all permits, and all concurrence meetings.

GEOENVIRONMENTAL SCOPE OF WORK (02/27/2006)**I. DESCRIPTION OF WORK**

The Department identified twelve known contaminated areas within the project corridor as listed below:

1. Anne Collins Property, Parcel 26
2. Living Water Baptist Church Property, Parcel 32
3. JSJ Associates Property, Parcel 35
4. Community Café, Inc. Property, Parcel 48
5. Roy Walter Property, Parcel 56
6. Walter and Donna Laney (NCDOT) Property, Parcel 67
7. David Segrest Property, Parcel 84
8. Robert Mills Property, Parcel 85
9. Dorothy Medlin, Inc. Property, Parcel 95
10. Marty Helms Property, Parcel 100
11. Cynthia Zipp Property, Parcel 101
12. David Wilson Property, Parcel 134

Department Responsibilities**1. Anne Collins Property, Parcel 26**

- Acquire right of way
- Remove known underground storage tanks and excavate contaminated soil
- Provide GeoEnvironmental Plan Sheets
- Provide Right of Way Recommendations

2. Living Water Baptist Church Property, Parcel 32

- Acquire right of way
- Excavate contaminated soil identified as Unavoidable Excavation as noted below
- Provide GeoEnvironmental Plan Sheets
- Provide Right of Way recommendations

3. JSJ Associates Property, Parcel 35

- Acquire right of way
- Excavate contaminated soil identified as Unavoidable Excavation as noted below
- Provide GeoEnvironmental Plan Sheets
- Provide Right of Way recommendations

4. Community Café Property, Parcel 48

- Abandon and relocate monitoring wells as necessary
- Provide GeoEnvironmental Plan Sheets
- Provide Right of Way Recommendations

5. Roy Walters Property, Parcel 56

- Acquire right of way
- Excavate contaminated soil identified as Unavoidable Excavation as noted below
- Provide GeoEnvironmental Plan Sheets
- Provide Right of Way Recommendations

6. Walter and Donna Laney (NCDOT) Property, Parcel 67

- Excavate contaminated soil identified as Unavoidable Excavation as noted below
- Provide GeoEnvironmental Plan Sheets
- Provide Right of Way Recommendations

7. David Segrest Property, Parcel 84

- Acquire right of way
- Excavate contaminated soil identified as Unavoidable Excavation as noted below
- Provide GeoEnvironmental Plan Sheets
- Provide Right of Way Recommendations

8. Robert D. Mills Property, Parcel 85

- Acquire right of way
- Excavate contaminated soil identified as Unavoidable Excavation as noted below
- Provide GeoEnvironmental Plan Sheets
- Provide Right of Way Recommendations

9. Dorothy Medlin Property, Parcel 95

- Remove known underground storage tank and excavate contaminated soil
- Provide GeoEnvironmental Plan Sheets
- Provide Right of Way Recommendations

10. Marty Helms Property, Parcel 100

- Acquire right of way
- Excavate contaminated soil identified as Unavoidable Excavation as noted below
- Provide GeoEnvironmental Plan Sheets
- Provide Right of Way Recommendations

11. Cynthia Zipp Property, Parcel 101

- Acquire right of way
- Remove known underground storage tanks and excavate contaminated soil
- Provide GeoEnvironmental Plan Sheets
- Provide Right of Way Recommendations

12. David Wilson Property, Parcel 134

- Acquire right of way
- Remove known underground storage tank and excavate contaminated soil
- Provide GeoEnvironmental Plan Sheets
- Provide Right of Way Recommendations

Site Specific Design-Build Team Responsibilities**1. Anne Collins Property, Parcel 26**

- No action required

2. Living Water Baptist Church Property, Parcel 32

- Eliminate or minimize excavation on this site in the areas shown on the GeoEnvironmental Plan Sheets provided by the Department.
- Quantify, in the Technical Proposal, the amount of Unavoidable Excavation required by the Design-Build Team's design as defined below.
- Excavate and dispose of contaminated materials caused by Excessive Excavation as defined below.

3. JSJ Associates Property, Parcel 35

- Eliminate or minimize excavation on this site in the areas shown on the GeoEnvironmental Plan Sheets provided by the Department.
- Quantify, in the Technical Proposal, the amount of Unavoidable Excavation required by the Design-Build Team's design as defined below.
- Excavate and dispose of contaminated materials caused by Excessive Excavation as defined below.

4. Community Café Property, Parcel 48

- Eliminate excavation on this site in the areas shown on the GeoEnvironmental Plan Sheets provided by the Department.
- Excavate and dispose of contaminated materials caused by Excessive Excavation as defined below.
- Acquire right of way and notify the Department of the acquisition.

5. Roy Walters Property, Parcel 56

- Eliminate or minimize excavation on this site in the areas shown on the GeoEnvironmental Plan Sheets provided by the Department.
- Quantify, in the Technical Proposal, the amount of Unavoidable Excavation required by the Design-Build Team's design as defined below.
- Excavate and dispose of contaminated materials caused by Excessive Excavation as defined below.

6. Walter and Donna Laney (NCDOT) Property, Parcel 67

- Eliminate or minimize excavation on this site in the areas shown on the GeoEnvironmental Plan Sheets provided by the Department.
- Quantify, in the Technical Proposal, the amount of Unavoidable Excavation required by the Design-Build Team's design as defined below.
- Excavate and dispose of contaminated materials caused by Excessive Excavation as defined below.

7. David Segrest Property, Parcel 84

- Eliminate or minimize excavation on this site in the areas shown on the GeoEnvironmental Plan Sheets provided by the Department.
- Quantify, in the Technical Proposal, the amount of Unavoidable Excavation required by the Design-Build Team's design as defined below.
- Excavate and dispose of contaminated materials caused by Excessive Excavation as defined below.

8. Robert Mills Property, Parcel 85

- Eliminate or minimize excavation on this site in the areas shown on the GeoEnvironmental Plan Sheets provided by the Department.
- Quantify, in the Technical Proposal, the amount of Unavoidable Excavation required by the Design-Build Team's design as defined below.
- Excavate and dispose of contaminated materials caused by Excessive Excavation as defined below.

9. Dorothy Medlin Property, Parcel 95

- No Action Required

10. Marty Helms Property, Parcel 100

- Eliminate or minimize excavation on this site in the areas shown on the GeoEnvironmental Plan Sheets provided by the Department.
- Quantify, in the Technical Proposal, the amount of Unavoidable Excavation required by the Design-Build Team's design as defined below.
- Excavate and dispose of contaminated materials caused by Excessive Excavation as defined below.

11. Cynthia Zipp Property, Parcel 101

- No action required

12. David Wilson Property, Parcel 134

- No action required

Right of Way Acquisition

The Design-Build Team shall acquire the right of way for the parcels noted above as early as possible. The Department will require 120 days after acquisition of the right of way to conduct the work noted above. The Design-Build Team shall notify the State Alternative Delivery Systems Engineer, in writing, approximately 30 days prior to the anticipated date of acquisition for each parcel. The Design-Build Team shall adhere to all right of Way Branch procedures regarding the acquisition of contaminated property and the Right of Way Acquisition Recommendations provided by the Department.

Removal of Contaminated Soil for Unavoidable Excavation

Unavoidable Excavation is defined as all excavation noted above required by the Design-Build Team's design and as submitted in the Technical Proposal. If the Design-Build Team's design requires Unavoidable Excavation on contaminated sites, the Department will remove these materials to a quantity equal to the amount noted in the Technical Proposal. In such case, the Design-Build Team shall provide plans and cross sections for the proposed excavation. For removal of these materials, the Design-Build Team shall allow the Department 120 days from (1) the time the approved plans and cross sections are submitted or (2) the date the property is vacated, whichever is later. The removal performed by the Department can occur prior to the acquisition of permits.

Removal of Contaminated Soil on Contaminated Sites for Excessive Excavation

Excessive Excavation is defined as any excavation on contaminated sites noted above that exceeds the amounts noted in the Technical Proposal or approved excavation plans and cross sections. The Design-Build Team shall be responsible for the removal of contaminated soils only to the extent that the excavation exceeds the amount noted in the Technical Proposal or approved excavation plans and cross sections. The removal performed by the Design-Build Team shall not occur prior to obtaining all permits for the project. All contaminated soils shall be removed in accordance with Section IV below.

Drainage within Contaminated Areas

If excavation is required for drainage purposes within contaminated areas, and is below the water table as shown in the geotechnical profile, the Design-Build Team shall construct a sealed drainage system in these areas.

Contamination by Design-Build Team

The Design-Build Team shall be responsible for any costs (direct or indirect) associated with damage and or cleanup of a hazardous substance and / or oil spill caused by it or its agent. This responsibility shall extend to freight carriers hired by the Design-Build Team to deliver a commodity or service to the Department. The Design-Build Team shall comply with all Local, State, and Federal requirements for the proper handling of hazardous substances and / or oil. In addition, the Design-Build Team agrees to indemnify and hold the Department harmless against all claims, liabilities, and costs, including attorneys' fees, incurred in the defense of any claim brought against the Department resulting from such a spill.

II. INFORMATION PROVIDED BY NCDOT

- Mary Collins Taylor Property Assessment Report, Parcel 26
- Living Waters Baptist Church Property Assessment Report, Parcel 32
- JSJ Associates Property Assessment Report, Parcel 35
- Heath Baucom Property Assessment Report, Parcel 38 (No Contamination Found)
- Community Café Property Assessment Report, Parcel 48
- Roy Walters Property Assessment Report, Parcel 56
- NCDOT/Maude Parker Property Assessment Report, Parcel 67
- David Segrest Property Assessment Report, Parcel 84
- Robert Mills Property Assessment Report, Parcel 85
- Dorothy Medlin Property Assessment Report, Parcel 95
- Marty Helms Property Assessment Report, Parcel 100
- Cynthia Zipp Property Assessment Report, Parcel 101
- Shelton Corwin Property Assessment Report, Parcel 131 (No Contamination Found)
- David Wilson Property Assessment Report, Parcel 134
- GeoEnvironmental Plan Sheets
- Revised Right of Way Recommendations (February 23, 2006)

III. UNKNOWN CONTAMINATED SITES

The Design-Build Team shall immediately notify the Department when the Design-Build Team's operations encounter or expose any abnormal condition which may indicate the presence of a hazardous, contaminated, and / or toxic material not previously identified in the Preliminary Environmental Site Assessments. Unknown contaminated sites will be addressed in accordance with Article 107-26 of the Standard Specifications, Division One, contained elsewhere in this RFP. The Engineer may elect to have the Design-Build Team remove and dispose of contaminated material within an unknown contaminated site as a supplemental agreement in accordance with the aforementioned Article 107-26 and Section IV below, or the Department will remove and dispose of contaminated material within an unknown contaminated site within fifteen business days after notification, in writing, by the Design-Build Team.

IV. DESIGN-BUILD TEAM REMOVAL OF CONTAMINATED SOILS AND WATER

This Section IV applies only if removal of contaminated material is to be performed by the Design-Build Team. As an alternative, the Design-Build Team can stockpile contaminated material according to all local, state and federal guidelines and the Department will dispose of the material under a separate purchase order contract within 60 days of notification by the Contractor.

The Design-Build Team shall employ a fully experienced and qualified geoenvironmental firm to dispose of contaminated soil and groundwater and any other contaminants removed from within the project right of way during construction activities. The Design-Build Team shall furnish and deliver to the Department three (3) reports accompanied by all documents necessary to meet the laws, rules and regulations of the environmental regulatory agency(ies) having jurisdiction over each respective site from which waste materials are removed. Reports documenting the Design-Build Team's work and laboratory analyses of collected samples shall be submitted to the Department within 30 calendar days after its completion. If the Design-Build Team removes any unanticipated underground storage tanks, a UST Closure Report shall be presented to the Department within twenty-five (25) calendar days after receipt of laboratory data. The Design-Build Team shall not submit any reports directly to the regulatory agencies.

Contaminated material and / or water removed during construction shall be transported to a waste treatment / disposal facility that is fully approved and permitted by all applicable environmental regulatory agencies to receive, treat and / or dispose of the material. It shall be the Design-Build Team's responsibility to locate such a facility. Departmental approval of the specific facility identified for use by the Design-Build Team shall occur prior to removal of any materials from the project limits. The Design-Build Team shall provide to the Department all transportation manifests and certificates of acceptance from the receiving disposal facility on a weekly basis. The Design-Build Team shall present all disposal manifests to the Engineer within twenty (20) days of completion of the

excavation. The Design-Build Team shall provide to the Department a Certificate of Remediation from the disposing / treating facility within sixty (60) days after removal of the materials from the project site unless alternate arrangements are approved in writing by the Department. The Department will be the regulatory generator of all waste excavated and removed from within its right of way. The Design-Build Team shall act as agents of the Department for signing all waste transportation and disposal manifests as necessary.

The Design-Build Team shall maintain qualified personnel onsite at all times during removal of materials from within known areas of contamination to monitor ambient air quality. The qualified personnel shall be knowledgeable with the use of an Organic Vapor Analyzer, Flame Ionization Detector, Photo Ionization Detector, or similar equipment.

The Design-Build Team shall be entirely responsible for compliance with all OSHA, EPA, DOT, DENR and local rules and regulations pertaining to excavation, transportation and treatment / disposal of the contaminated media. Examples of such rules and regulations include, but are not limited to, 29 CFR 1910 and 1926, 40 CFR 260 - 265, 49 CFR 173 and 178, 15A NCAC 13A North Carolina Hazardous Waste Management Rules, NCGS 130A - 310 Inactive Hazardous Sites, the Federal Comprehensive Environmental Response, Compensation and Liability Act (CERCLA) and the Federal Resource Conservation and Recovery Act (RCRA). It must be noted that inclusion of this paragraph is meant to highlight the Design-Build Team's responsibility for regulatory compliance in all phases of work on this project.

Disposal of Contaminated Water

Contaminated water shall be appropriately collected, containerized and disposed of by the Design-Build Team at a disposal facility fully licensed to handle contaminated materials.

Cleaning of Equipment and Vehicles

All equipment, tools, etc. utilized in the removal of contaminated materials shall be thoroughly cleaned to the satisfaction of the Engineer prior to leaving the project limits. In addition, all water used in the cleaning operation shall be appropriately collected, containerized and disposed of by the Design-Build Team as required by regulations in the preceding paragraph.

No vehicles exiting the known contaminated areas shall leave soil or other debris on public or private roadways. Provisions for ensuring all vehicle tires are free from contaminated soil or debris prior to exiting the project limits shall be the responsibility of the Design-Build Team for the duration of the project.

Dust shall not be produced by the excavation activities in areas of known contamination. It is the Design-Build Team's responsibility to provide dust control throughout the duration of the project.

EROSION AND SEDIMENTATION CONTROL SCOPE OF WORK (2-8-06)

Erosion and Sedimentation Control Plans shall at a minimum address the following:

I. Complete Set of Plans**A. Clearing and Grubbing Phase**

1. Use correct NCDOT symbology
2. Protect existing drainage structure inlets with Rock Inlet Sediment Trap Type 'A' (RIST-A), Rock Inlet Sediment Trap Type 'C' (RIST-C), Rock Pipe Inlet Sediment Trap Type 'A' (PIST-A), etc.
3. Utilize adequate perimeter controls (temporary diversions, silt fence, etc.)
4. Utilize rock measures with sediment control stone at drainage outlets (Temporary Rock Sediment Dam Type 'B' (TRSD-B), Temporary Rock Silt Check Type 'A' (TRSC-A), etc.)
5. Take into account existing topography and show contour lines
6. Utilize Temporary Rock Silt Checks Type 'B' (TRSC-B) to reduce velocity in existing ditches with spacing of 300 feet divided by percentage of ditch grade
7. Protect existing streams
8. Provide adequate silt storage for 1800 cubic feet per disturbed acre and sediment basins shall be sized with surface area equal to 0.01 times the peak inflow rate, Q₂₅, using 25-year peak runoff data (*NCDENR- Erosion and Sediment Control Planning and Design Manual*). A Sediment Basin Designer Spreadsheet will be provided by the NCDOT Roadside Environmental Unit (REU)
9. Design Riser Basins to the following standards:
 - a. Surface Area shall be determined by Equation $A(\text{sq. ft.}) = Q_{10}(\text{cfs}) * 435.6$
 - b. Riser Pipe shall have a cross-sectional area 1.5 times that of the barrel pipe
 - c. Perforations in the riser pipe shall be reduced to increase dewatering time to twenty-four (24) hours
 - d. See *NCDENR- Erosion and Sediment Control Planning and Design Manual* for additional design criteria

B. Intermediate and Final Grade Phases

1. Use correct NCDOT symbology
2. Protect existing and proposed drainage structure inlets with RIST-A, RIST-C, PIST-A, etc.
3. Utilize TRSC-B's to reduce velocity in existing and proposed ditches with spacing of 300 feet divided by percentage of ditch grade
4. Utilize temporary slope drains and earth berms at top of fill slopes 8 feet or higher and a fill slope grade of 3:1 or steeper, or where there are super elevations above 0.04 and fills are greater than 5 feet. Maximum slope drain spacing shall be 200 feet
5. Utilize rock energy dissipater and / or silt basin at outlet of slope drain
6. Devices at all drainage turnouts shall utilize sediment control stone (TRSD-B, TRSC-A, etc.)

7. Provide adequate silt storage for 1800 cubic feet per disturbed acre and sediment basins shall be sized with surface area equal to 0.01 times the peak inflow rate, Q25, using 25-year peak runoff data (*NCDENR- Erosion and Sediment Control Planning and Design Manual*) A Sediment Basin Designer Spreadsheet will be provided by NCDOT REU
8. Provide matting for erosion control in all ditch lines where Shear Stress is greater than 0.15 psf, but less than or equal to 1.55 psf. For ditch lines with a Shear Stress above 1.55 psf, Permanent Soil Reinforcement Mat or Rip Rap shall be utilized
9. Design Riser Basins to the following standards:
 - a. Surface Area shall be determined by Equation $A(\text{sq. ft.}) = Q10(\text{cfs}) * 435.6$
 - b. Riser Pipe shall have a cross-sectional area 1.5 times that of the barrel pipe
 - c. Perforations in the riser pipe shall be reduced to increase dewatering time to twenty-four (24) hours
 - d. See *NCDENR- Erosion and Sediment Control Planning and Design Manual* for additional design criteria
10. Provide the overall Erosion and Sedimentation Control Plan for period between Clearing and Grubbing and Final Grade if needed

II. Detail Sheets and Notes

- A. Provide construction entrance detail
- B. Provide project specific special details and notes
- C. Provide reforestation sheet(s): regular, wetland, streambank showing appropriate species

III. Title Sheet

- A. Show correct notes: HQW, ESA, clearing and grubbing, etc.
- B. Show correct standards for project
- C. List of standard NCDOT symbology

IV. Special Provisions

- A. Erosion Control Special Provisions are available at the following website:
http://www.ncdot.org/doh/operations/dp_chief_eng/roadside/soil_water/special_provisions/
- B. References in the Erosion Control Special Provisions from the aforementioned website to Method of Measurement, Basis of Payment, or any other statement regarding direct payment for Erosion and Sediment Control measures shall be disregarded.
- C. Erosion Control / Stormwater Certification found elsewhere in this proposal

V. Miscellaneous

- A. Plan submittals shall include all pertinent design information required for review, such as design calculations, drainage areas, etc.

- B. The NCDOT REU will provide a sample set of Erosion and Sedimentation Control Plans (including any special details or special provisions used by the NCDOT REU) and MicroStation Erosion Control Workspace to the Design-Build Team for reference upon request.
- C. Plans shall address any environmental issues raised during the permitting process.
- D. Sufficient time shall be allowed for the Design-Build Team to make any changes to the Erosion and Sedimentation Control Plans deemed necessary by the NCDOT REU.
- E. The NCDOT REU shall approve all Erosion and Sedimentation Control Plans. Release for Construction (RFC) Erosion and Sedimentation Control Plans shall be submitted to all NCDOT Personnel listed in the Design-Build Submittal Guidelines before **any** land disturbing activities can commence, or prior to the next phase of work that requires an Erosion and Sedimentation Control Plan.
- F. Temporary access and haul roads, other than public roads, constructed or used in connection with the project shall be considered a part of the project and addressed in the Erosion and Sedimentation Control Plans and Project Special Provisions.
- G. Borrow or waste areas that are part of the project shall require a separate Erosion and Sedimentation Control Plan, unless the borrow or waste activity is regulated under the *Mining Act of 1971*, or is a landfill regulated by the Division of Solid Waste Management (NCDENR). The Design-Build Team shall submit the permit number for waste / borrow sites covered by the Mining Act or regulated by DSWM (DENR) concurrently to the State Alternative Delivery Systems Engineer and the Resident Engineer.
- H. Whenever the Engineer determines that significant erosion and sedimentation continues despite the installation of approved protective practices, the Design-Build Team shall be required to and shall take additional protective action.
- I. Final Grade Erosion and Sedimentation Control Plans are final only if roadway drainage design has been completed and accepted by the State Alternative Delivery Systems Engineer.
- J. An approved Erosion and Sedimentation Control Plan does not exempt the Design-Build Team from making every effort to contain sediment onsite.
- K. Any Erosion Control Design revisions made during the construction of the project shall be submitted to REU by the 15th of the month. At anytime requested by the Engineer or the Roadside Environmental Unit, the Design-Build Team shall provide an updated version of the Erosion and Sedimentation Control Plans for distribution to all parties involved in the construction process.
- L. The Design-Build Team shall comply with the *North Carolina Administrative Code Title 15 A Department of Environment and Natural Resources Chapter 4, Sediment Control*.
- M. A pre-design meeting shall take place between the NCDOT REU Soil & Water Engineering Section, the Design-Build Team, and any other pertinent NCDOT personnel before Erosion and Sedimentation Control Design begins. Erosion and Sedimentation Control Plan submittals shall only be reviewed and approved by NCDOT REU after the Erosion Control Pre-Design Meeting.
- N. All RFC Erosion and Sedimentation Control Plans, including any red line revisions, shall be kept on site at all times throughout the duration of the project.
- O. Erosion Control / Stormwater Certification shall be required according to the Project Special Provision found elsewhere in this proposal.

ENVIRONMENTAL INCENTIVES:

The Design Build Team shall observe and comply with federal and state laws, local laws, ordinances, and regulations, orders, and decrees of bodies having any jurisdiction or authority in accordance with Section 107 of the Standard Specifications.

The Design Build Team will be eligible for an incentive in the amount of \$100,000 if construction operations have been performed in accordance with all environmental regulations and the Specifications, and no violations have been issued. Violations are defined as:

Violation	Issuing Entity
Immediate Corrective Action (ICA)	Department
Continuance of an ICA (CICA)	Department
Notice of Violation (NOV)	Regulatory Agencies
Cease and Desist (C&D)	Corp of Engineers

The incentive payment shall be paid at the completion of the project as long as the Design-Build Team does not receive any violations at any time during project construction.

EROSION CONTROL LIQUIDATED DAMAGES:

The Design-Build Team's first four violations shall result in a reduction of \$25,000 from the \$100,000 incentive noted above for each ICA, CICA, NOV or C&D violation. Beginning with the fifth violation, Liquidated Damages in the amount of \$25,000 per violation shall be deducted from other monies due the Design-Build Team.

The Design-Build Team shall take all reasonable precautions to comply with all regulations of all authorities having jurisdiction over public and private land governing the protection of erosion and sedimentation. Any fines, remediation required or charges levied against the Department for failing to comply with all rules and regulations concerning erosion and sediment control, due to the Design-Build Team's negligence, carelessness, or failure to implement the erosion and sediment control plan and specifications, shall be deducted from monies due the Design-Build Team. In addition to said fines, remediation required, or charges levied, any associated engineering costs or actions taken by the Department in order for the Department to comply with rules and regulations, as a result of the Design-Build Team's negligence, carelessness, or failure to implement the Erosion and Sedimentation Control Plans and Specifications, shall be deducted from the monies due to the Design-Build Team.

TRAFFIC CONTROL SCOPE OF WORK (2/13/06)**I. Traffic Control Plans****A. Design Parameters**

The Design-Build Team shall prepare the Traffic Control and Pavement Marking Plans for this project following the parameters listed below:

1. Maintain a minimum of one 11-foot lane in each direction of US 601 at all times, unless otherwise noted below.
2. Maintain existing shoulder widths unless there is a permanent obstruction, i.e. curb and gutter, guardrail, etc. In addition, if any traffic control device is utilized, then a minimum 2-foot offset (shy distance) shall be required from the edge of travel lane to the traffic control device.

Construction shall not begin until the first phase submittal meets the requirements of the RFP. The Staging Concept and Preliminary Pavement Marking Plans shall meet the RFP requirements before the first phase submittal can be submitted. Construction shall not begin on subsequent phase submittals until they meet the requirements of the RFP, the “Guidelines for Preparation of Traffic Control and Pavement Marking Plans for Design-Build Projects”, and the “Design- Build Submittal Guidelines”. If a temporary traffic barrier system will be used, the Staging Concept shall identify the proposed type of barrier system for approval by the State Alternative Delivery Systems Engineer.

B. Traffic Control and Final Pavement Marking Plan requirements:

The Design-Build Team shall select a Private Engineering Firm (PEF) that has a minimum of five years of designing and sealing Traffic Control and Pavement Marking Plans for the Department on comparable projects. The Technical Proposal shall list projects, including description and similarity to the subject project.

The development of Traffic Control and Pavement Marking Plans shall adhere to the “Design-Build Submittal Guidelines” and the “Guidelines for Preparation of Traffic Control and Pavement Marking Plans for Design-Build Projects”, which by reference are incorporated herein and made a part of the contract. These documents are available on the Design-Build website.

II. Project Operations Requirements

The following are Time Restrictions and notes that shall be included with the Traffic Control Plans General Notes:

A. Time Restrictions

1. Intermediate Contract Time for Lane Narrowing, Closure, Holiday and Special Event Restrictions.

As a minimum, the Design-Build Team shall maintain existing traffic patterns and shall not close or narrow a lane during the times below:

Road name	Times
US 601	<p>Monday to Friday - 7:00 a.m. to 9:00 a.m. and 4:00 p.m. to 6:00 p.m.</p> <p>From June 1st to Labor Day the time restrictions for Fridays shall be as follows: 7:00 a.m. to 9:00 a.m. and 4:00 p.m. to 9:00 p.m.</p> <p>Saturday and Sunday - 10:00 a.m. to 2:00 p.m.</p>

The Design-Build Team shall not install, maintain or remove any traffic control device required for narrowing or closing a lane during the times listed above.

During holidays, holiday weekends, special events, or any other time when traffic is unusually heavy on any of the roadways listed above, the Design-Build Team shall not close or narrow a lane of traffic, detain the traffic flow or alter the traffic flow. As a minimum, these requirements / restrictions apply to the following schedules:

- (a) For New Year's between the hours of 7:00 a.m. December 31st to 6:00 p.m. January 3rd. If New Year's Day is on a Friday, Saturday or a Sunday, then from 7:00 a.m. the Friday before to 6:00 p.m. the following Tuesday.
- (b) For Easter, between the hours of 7:00 a.m. Friday and 6:00 p.m. Tuesday.
- (c) For Memorial Day, between the hours of 7:00 a.m. Friday to 6:00 p.m. Wednesday.
- (d) For Independence Day, between the hours of 7:00 a.m. July 3rd and 6:00 p.m. July 6th. If Independence Day is on a Friday, Saturday or Sunday, between the hours of 7:00 a.m. the Thursday before Independence Day and 6:00 p.m. the Tuesday after Independence Day.
- (e) For Labor Day, between the hours of 7:00 a.m. Friday to 6:00 p.m. Wednesday.
- (f) For Thanksgiving, between the hours of 7:00 a.m. Tuesday to 6:00 p.m. Tuesday of the following week.

- (g) For Christmas, between the hours of 7:00 a.m. the Friday before the week of Christmas Day and 6:00 p.m. the following Tuesday after the week of Christmas Day.
- (h) For NASCAR events at Charlotte, NC and Darlington, SC, from 7:00 a.m. the Friday before the event to 6:00 p.m. Monday after the event.
- (i) For the Pageland Watermelon Festival in Pageland, SC, from 4:00 p.m. the Thursday before the event to 9:00 a.m. the Monday after the event.

Liquidated Damages for the above lane narrowing, lane closure, holiday and special event time restrictions for US 601 are \$1,000.00 per hour for this Intermediate Contract Time.

2. Intermediate Contract Time for Road Closure Restrictions for Construction Operations.

As a minimum, the Design-Build Team shall maintain the existing traffic pattern for all roadways and follow the road closure restrictions listed below. When a road closure is used, the Design-Build Team shall reopen the travel lanes by the end of the road closure duration to allow the traffic queue to deplete before re-closing the roadway.

In the Technical Proposal, the Design-Build Team shall address the road closure durations for the roads and respective operations listed in the time restrictions provided below. The Design-Build Team shall provide a traffic control concept on how traffic will be maintained in the Technical Proposal. A percentage of the Technical Proposal evaluation shall be dependent on this information.

- a) The Design-Build Team shall not close US 601 during the times listed below. Road Closures shall only be allowed for the operations and durations listed below the time restrictions.

US 601 Sunday to Saturday - 6:00 a.m. - 9:00 p.m.

Maximum road closure duration of **30 minutes** shall be allowed for the following operations:

- Traffic shifts, including tie-in work and placement of pavement markings
- Tie-in work for -Y- Lines, unless an approved detour route is operational.

Liquidated Damages for the above road closure time restrictions on US 601, are \$500.00 per 15 minute period or any portion thereof for this Intermediate Contract Time.

3. Hauling Restrictions

The Design-Build Team shall adhere to the hauling restrictions noted in the *2002 NCDOT Standard Specifications for Roads and Structures*.

The Design-Build Team shall address how hauling will be conducted in the Technical Proposal.

The Design-Build Team shall not conduct any hauling operations against the flow of traffic of an open travelway unless the work area is protected by approved temporary traffic barrier or guardrail.

B. Lane and Shoulder Closure Requirements

The Design-Build Team shall not install more than 2.0 miles of lane closures on any roadway within the project limits, measured from the beginning of the merge taper to the end of the lane closure.

The Design-Build Team shall not install more than one lane closure, in any one direction, on any roadway within the project limits and shall maintain a minimum of four miles between lane closures.

The Design-Build Team shall remove lane closure devices from the lane when work is not being performed behind the lane closure or when a lane closure is no longer needed.

When personnel and / or equipment are working within 40 feet of an open travel lane, the Design-Build Team shall close the nearest open shoulder using *Revised Roadway Standard Drawing No. 1101D04*, unless the work area is protected by approved temporary traffic barrier or guardrail. The aforementioned revised roadway standard drawing may be found on the NCDOT's Work Zone Traffic Control website.

<http://www.doh.dot.state.nc.us/construction/wztc/>

When personnel and / or equipment are working on the shoulder adjacent to an undivided facility and within 5 feet of an open travel lane, the Design-Build Team shall close the nearest open travel lane using *Roadway Standard Drawing No. 1101.02*, unless the work area is protected by barrier or guardrail.

When personnel and / or equipment are working on the shoulder adjacent to a divided facility and within 10 feet of an open travel lane, the Design-Build Team shall close the nearest open travel lane using *NCDOT 2002 Roadway Standard Drawings No. 1101.02*, unless the work area is protected by barrier or guardrail.

When personnel and / or equipment are working within a lane of travel of an undivided or divided facility, the Design-Build Team shall close the lane using the

appropriate roadway standard drawing from the NCDOT 2002 *Roadway Standard Drawings*. The Design-Build Team shall conduct the work so that all personnel and / or equipment remain within the closed travel lane.

The Design-Build Team shall not perform work involving heavy equipment within 15 feet of the edge of travelway when work is being performed behind a lane closure on the opposite side of the travelway.

C. Pavement Edge Drop off Requirements

The Design-Build Team shall backfill at a 6:1 slope up to the edge and elevation of existing pavement in areas adjacent to an opened travel lane that has a drop-off as follows:

Backfill drop-offs that exceed 2 inches on roadways with posted speed limits of 45 mph or greater.

Backfill drop-offs that exceed 3 inches on roadways with posted speed limits less than 45 mph.

Backfill drop-off with acceptable material and compact at no expense to the Department.

Do not exceed a difference of 1.5 inches in elevation between open lanes of traffic. Install advance warning "UNEVEN LANES" signs (W8-11) 500 feet in advance.

OR

Do not exceed a difference of 2.0 inches in elevation between open lanes of traffic. If the difference between open lanes is between 1.5 inches and 2.0 inches, provide a 1:1 slope at edge of pavement separating the lanes of travel. Install advance warning "UNEVEN LANES" signs (W8-11) 500 feet in advance and a minimum of once every ½ mile throughout the uneven area.

D. Traffic Pattern Alterations

The Design-Build Team shall notify the Engineer twenty-one (21) calendar days prior to any traffic pattern alteration. See the Public Involvement Scope of Work for providing information to the public.

E. Signing

The Design-Build Team shall install advance work zone warning signs when work is within 100 feet from the edge of travel lane and no more than three days prior to the beginning of construction.

When no work is being conducted for a period longer than one week, the Design-Build Team shall remove or cover all advance work zone warning signs, as directed by the Engineer, at no cost to the Department.

All detour signing shall be the responsibility of the Design-Build Team. The Design-Build Team shall provide detailed information on the route, devices required and why needed in the Staging Concept. Possible detour needs could include but are not be limited to road closures, limited horizontal (17' clear width or less) or vertical clearance limits, grade changes in tie in areas and oversize and / or overweight limits.

The Design-Build Team shall cover or remove all detour signs within and off the project limits when a detour is not in operation.

The Design-Build Team shall ensure all necessary signing is in place prior to altering any traffic pattern.

The Design-Build Team shall maintain all Guide Signs throughout the life of the project, and remove any Guide Signs when the signs are no longer applicable.

F. Traffic Barrier

The Department will not provide any moveable barrier or transfer vehicles for this project. The Design-Build Team shall adhere to the following requirements:

Install an approved temporary traffic barrier system a maximum of two (2) weeks prior to beginning work in any location. Once the approved temporary traffic barrier system is installed at any location, proceed in a continuous manner to complete the proposed work in that location.

Once the approved temporary traffic barrier system is installed and if no work has been performed behind the approved temporary traffic barrier system for a period longer than two (2) months, remove / reset the approved temporary traffic barrier system at no cost to the Department, unless barrier is protecting a hazard.

Protect the approach end of the approved temporary traffic barrier system at all times during the installation and removal of the barrier. If system requires installation of a temporary crash cushion, a truck mounted impact attenuator can be used for a maximum of 72 hours until the temporary crash cushion can be installed.

Offset the approach end of the approved temporary traffic barrier system a minimum of 40 feet from oncoming traffic or protect at all times by a temporary crash cushion if the approved temporary traffic barrier system requires a temporary crash cushion.

Install approved temporary traffic barrier system with the traffic flow, beginning with the upstream side of traffic. Remove the approved temporary traffic barrier system against the traffic flow, beginning with the downstream side of traffic.

Install and space drums no greater than twice the posted speed limit (mph) to close or keep closed the section of the roadway until the barrier can be placed or after barrier is removed.

The Design-Build Team shall be responsible for providing a safe area (lateral offset behind barrier to work area) behind the approved temporary barrier system in accordance with the NCHRP-350 deflections from crash testing. If the safe area can not be maintained, an anchored barrier system shall be required.

G. Traffic Control Devices

The Design-Build Team shall adhere to the following requirements:

Use traffic control devices that conform to all NCDOT requirements and are listed on the Department's Approved Products List as shown on NCDOT's Work Zone Traffic Control website. Use of devices not shown on the Approved Product List shall require approval from the State Alternative Delivery Systems Engineer.

All drums shall meet the requirements of the Drum Standard Detail found on the NCDOT's Work Zone Traffic Control website .

<http://www.doh.dot.state.nc.us/construction/wztc/>

Space channelizing devices in work areas no greater than twice the posted speed limit (mph), except 10 feet on-center in radii, and 3 feet off the edge of an open travelway, when lane closures are not in effect.

Place Type III barricades, with "ROAD CLOSED" Sign R11-2 attached, of sufficient length to close entire roadway. Stagger or overlap barricades to allow for ingress or egress.

Place sets of three drums perpendicular to the edge of the travelway on 500-foot centers when unopened lanes are closed to traffic. These drums shall be in addition to channelizing devices.

The Design-Build Team shall install and leave on the project the Traffic Control Devices that are in good condition necessary to accommodate the traffic pattern shown in accordance with the RFC - Traffic Control and Final Pavement Marking Plans, unless otherwise directed by the Engineer. The devices required to remain on the project at its completion shall become the property of the Department.

H. Pavement Markings, Markers and Delineation

The Design-Build Team shall adhere to the following:

Placement of final pavement markings and markers shall proceed only if the Final Pavement Marking Plans meet the requirements of the RFP, the “Guidelines for Preparation of Traffic Control and Pavement Marking Plans for Design-Build Projects”, and the “Design-Build Submittal Guidelines”.

The Design-Build Team shall use pavement marking and marker products that conform to all NCDOT’s requirements and specifications, as listed on the Department’s Approved Products List located on the NCDOT’s Work Zone Traffic Control website.

<http://www.doh.dot.state.nc.us/construction/wztc/>

The Design-Build Team shall install pavement markings and markers in accordance with NCDOT’s 2002 *Standard Specifications for Roads and Structures*, and in accordance with the manufacturer’s procedures and specifications.

The Final Pavement Marking Plans shall address any changes to markings outside the project limits as a result of the proposed construction of this project. The Design-Build Team shall be responsible for installing such markings and markers.

The Design-Build Team shall install pavement markings and pavement markers on the final surface as follows:

Road	Marking	Marker
Asphalt surfaces	Thermoplastic or Polyurea	Raised Permanent

All US routes require 50% wider markings, i.e., lane lines, edge lines and skips shall be 6”.

Refer to the Polyurea Special Provision, which is available on the NCDOT’s Work Zone Traffic Control website.

The Design-Build Team shall install temporary pavement markings and temporary pavement markers on the interim surface or temporary pattern as follows:

Road	Marking	Marker
All Roads and Existing Structures.	Minimum of Paint	Temporary Raised
Proposed Structures	Temporary Tape	Temporary Raised

When using temporary tape pavement markings, place temporary raised markers half on and half off edgelines and centerlines to help secure the tape to the roadway. Markers shall be spaced the appropriate distance apart as described by RSD 1250.01, sheet 1 of 3.

Trace the edge of proposed monolithic islands with the proper color pavement marking prior to installation of a proposed monolithic island.

Place at least two applications of paint on the final wearing surface on new asphalt pavement. Place additional applications of paint upon sufficient drying time, as determined by the Engineer.

Place at least two applications of paint for temporary traffic patterns that will remain in place over three (3) months. Place additional applications of paint upon sufficient drying time, as determined by the Engineer.

Tie proposed pavement marking lines to existing pavement marking lines.

Replace any pavement markings that have been damaged by the end of each day's operation.

Remove any conflicting markings or markers before shifting traffic to a new pattern.

Removal of the temporary pavement markings shall be accomplished by using water blasting, sand blasting, shot blasting systems or other approved systems to minimize damage to the road surface. All systems shall be required to remove 100% of the pavement marking without removing more than 1/32 inch" of the pavement surface.

I. Temporary / Final Signals

Temporary or Final Signals are not expected for this project.

J. Miscellaneous

The Design-Build Team shall adhere to the following:

Provide portable temporary lighting to conduct night work in accordance with the NCDOT *Standard Specifications for Roads and Structures*.

Police may be used to maintain traffic through intersections. The Design-Build Team shall be responsible for coordinating with the law enforcement agency if they will be used. The Traffic Control Staging Concept shall address when police will be used, where they will be used, duration and why. Utilize Officers who are outfitted with law enforcement uniforms and marked Vehicles, which are equipped with proper lights mounted on top of the vehicle, and agency emblems.

Coordinate with the Engineer in charge of any project in the vicinity of this project for any work that may effect the construction and the Traffic Control of this project.

Maintain Pedestrian traffic through project, use the MUTCD to provide appropriate information.

Guidelines for speed reduction and \$250 speeding penalty ordinances are located on the NCDOT's Work Zone Traffic Control website. If the Traffic Control Plans can not be designed to eliminate the need for the ordinances and they meet the criteria listed in the guidelines, then an engineering study shall be required. Submit a formal Request to the State Alternate Delivery Systems Engineer that states why the ordinance is needed and why the Traffic Control Plans can not be designed differently to avoid the need for the ordinance. Identify the need in the Technical Proposal and submit this request once the project is awarded with pre-Staging Concept Plan and allow 6 weeks for the Department to complete the study and provide ordinance(s) if approved.

Temporary Shoring for the Maintenance of Traffic may be required, and estimated locations where temporary shoring could be used shall be identified in the Staging Concept.

The Design-Build team shall include the following in the Traffic Control Plans.

1. Identify on the appropriate Traffic Control detail where temporary shoring will be used by providing station limits and offsets and what type of shoring will be used, Temporary Shoring, Temporary Shoring Barrier Supported or other type if the standard shoring doesn't apply.
2. Identify the proper soil parameters when designing temporary shoring for this project, the Traffic Control detail that shows temporary shoring shall include these parameters on the plan sheet.

“For Design of Temporary Shoring, use the following soil parameters:

Unit weight of soil above water table = X kN/m³

Unit weight of soil below water table = X kN/m³

Friction Angle, (phi) = X degrees

Cohesion, c = X kPa”

SIGNING SCOPE OF WORK (2-10-06)

General: The Design-Build Team shall prepare the Signing Plans in accordance with the latest edition of the *2003 Manual on Uniform Traffic Control Devices (MUTCD)*, the *2004 NC Supplement to the MUTCD*, *NCDOT Standard Specifications for Roads and Structures* (January 2002), the NCDOT Roadway Standard Drawings (January 2002) for the design and development of signing plans, the latest Standard Specifications for *Structural Supports for Highway Signs, Luminaires, and Traffic Signals* published by AASHTO, the *Guidelines for Preparation of Signing Plans for Design-Build Projects* and the contract requirements for signing plan design, preparation and construction contained herein. All electrical installations and coordination shall be the responsibility of the Design-Build Team and must meet NEC, State, and local codes. All electrical / electronics equipment and devices must be UL approved and listed.

Signing Plan Requirement: The Design-Build Team shall select a Private Engineering Firm (PEF) that has experience in designing and sealing Signing Plans for NCDOT on comparable projects. The Technical Proposal shall list projects, including description and similarity to the subject project, developed by the PEF. **The Design-Build Team shall include preliminary signing design for this project in the Technical Proposal.**

Signs Furnished by Design-Build Team: The signs shall be furnished by the Design-Build Team according to the specifications provided by the Department.

Signing Project Limits: The Design-Build Team shall be responsible for the design, fabrication and installation of all signs required through the construction limits of the mainline, all –Y- Lines and all cul-de-sacs. The Design-Build Team shall also be responsible for the design, fabrication and installation of all signs required beyond the construction limits of the mainline, all –Y- Lines and all cul-de-sacs to ensure adequate advance signage is provided.

The anticipated posted speed limit for US 601 is 55 mph. The Design-Build Team shall coordinate the posted speed limits for US 601, as well as all –Y- Lines and cul-de-sacs, with the Regional Traffic Engineer.

Sign Design: The Design-Build Team shall be responsible for the design, fabrication and installation of all signs required for the mainline, as well as all -Y- Lines and cul-de-sacs. The Design-Build Team shall be responsible for designing, fabricating and installing the appropriate State Line signing on the facility. The Design-Build Team shall detail in their Technical Proposal the signing proposed at the directional crossovers to prevent counterflow movements and U-Turn maneuvers (**See Roadway Scope of Work**). The Design-Build Team shall detail in their Technical Proposal the signing proposed at the median U-Turns. The Design-Build Team shall be responsible for all Type A, B, and D sign designs, fabrication and installation for ground mounted signs. The Design-Build Team shall be responsible for determining, sizing, fabricating, locating and installing all Type E (warning and regulatory signs) and Type F signs (route marker assemblies). All sign designs shall be included in the Signing Plans. All sign designs shall be prepared using the latest version of GuideSign software.

Sign Maintenance: The Design-Build Team shall maintain all existing signs during construction, including temporary installations of **guide signs** on supports in accordance with Section 908-3(C) of *NCDOT Standard Specifications for Roads and Structures* to ensure signs are properly maintained and visible during project construction. The Design-Build Team shall be responsible for designing and installing temporary sign supports.

Sign Locations: The Design-Build Team shall be responsible for determining the station locations for all signs. To avoid sign placement in locations where their usefulness will be short-lived, the Design-Build Team shall coordinate the proposed sign designs and locations with existing and future projects through the Department.

Ground Mounted Support Designs: NCDOT will provide the software for ground mounted sign support designs. The Design-Build Team shall be responsible for all designs, fabrication, and installation of ground mounted supports and signs. Instructions for loading support design software will be made available.

Guardrail or Other Protection for Ground Mounted Signs: The Design-Build Team shall be responsible for determining, designing and installing any protection for proposed and existing sign supports.

Signing Typical Sheets: Sheets to be used in summarizing quantities, standard specifications, and compiling Type E and F signs will be provided by the Department electronically.

Removal and Disposal of Existing Signs: The Design-Build Team shall be responsible for determining those existing signs that will no longer be needed upon completion of the project, such as on -Y- Lines and project tie-ins. The Design-Build Team shall be responsible for removal and disposal of these signs and supports. The Design-Build Team shall show and note these signs on the signing plan view sheets.

Signing Construction Revisions: All construction revisions shall be submitted to the Department for review.

UTILITIES COORDINATION SCOPE OF WORK (2-24-06)**• Overview**

The Design-Build Team shall obtain the services of a Private Engineering Firm (PEF) knowledgeable in the NCDOT Utility Coordination Process, involved with utility relocation / installation and highway construction. The Design-Build Team shall be responsible for coordinating all utility relocations. Coordination shall include any necessary utility agreements when applicable. The NCDOT will be responsible for non-betterment utility relocation cost when the utility company has prior rights of way / compensable interest. The utility company shall be responsible for the relocation costs if they can not furnish evidence of prior rights of way or a compensable interest in their facilities. The Design-Build Team shall be responsible for determining the cost responsibility for the utility relocations. The Design-Build Team shall be responsible for all costs associated with utility relocations due to haul roads and / or any other temporary conditions resulting from the Design-Build Team's methods of operation or sequence of work. NCDOT will be the approving authority for all utility agreements and approval of plans.

• Preparation for relocating utilities within the existing or proposed highway Rights of Way

I. The Design-Build Team shall be required to use the guidelines as set forth in the following:

- (A) *NCDOT Utility Manual - Policies & Procedures for Accommodating Utilities on Highway Rights of Way*
- (B) *Federal Aid Policy Guide- Subchapter G, Part 645, Subparts A & B*
- (C) *Federal Highway Administration's Program Guide, Utility Adjustments & Accommodations on Federal Aid Highway Projects*
- (D) *NCDOT Construction Manual Section 105-8*
- (E) *NCDOT Right of Way Manual - Chapter 16 Utility Relocations*
- (F) *NCDENR Public Water Supply - Rules governing public water supply*
- (G) *NCDENR Division of Water Quality - Title 15A - Environment and Natural Resources*

II. The Design-Build Team shall be responsible for confirming the utility locations, confirming the type of facilities, identifying the utility owners and determining the cost responsibilities in order to coordinate the relocation of any utilities in conflict with the project.

• Arrangements for Protection or Adjustments to Existing Utilities

I. The Design-Build Team shall make the necessary arrangements with the utility owners for adjustments, relocations or removals where the Design-Build Team and Utility Company, with concurrence from the Department, determine that such work is essential for highway safety and performance of the required construction.

The Design-Build Team shall not commence work at points where the highway construction operations are adjacent to utility facilities, until making arrangements with the utility company to protect against damage that might result in expense, loss, disruption of service or other undue inconvenience to the public or utility owner. The Design-Build Team shall be responsible for damage to the existing or relocated utilities resulting from his operations. In the event of interruption of any utilities by the project construction, the Design-Build Team shall promptly notify the proper authority (Utility Company) and cooperate with the authority in the prompt restoration of service.

The Design-Build Team shall accommodate utility adjustments, reconstruction, new installation and routine maintenance work that may be underway or take place during the progress of the contract.

- II.** In the event of a utility conflict, the Design-Build Team shall request that the utility company submit relocation plans (Highway Construction Plans to be provided by the Design-Build Team to Utility Owners) that show existing utilities and proposed utility relocations for approval by the NCDOT.

The Design-Build Team shall be required to submit (3) three copies of the Utility Relocation Plans to the NCDOT State Utility Agent for review and approval prior to relocation work beginning. If the Design-Build Team determines the cost to be borne by NCDOT, then the Design-Build Team shall be required to submit three (3) copies of a detailed utility relocation estimate and copies of verification of compensable interest. The Design-Build Team shall also be responsible for submitting the appropriate agreements to be used with the relocation plans (See Agreements under line items V and VI). After the review process is complete, the NCDOT Utility Unit will submit one (1) copy of the Utility Relocation Plans, executed agreements and any necessary comments back to the Design-Build Team. The NCDOT Utility Unit will also submit a copy of the approved Utility Relocation Plans to the Department's Resident Engineer. If the Utility Relocation Plans are approved subject to changes, it shall be the Design-Build Team's responsibility to coordinate these changes with the appropriate utility company.

- III.** The cost for non-betterment utility relocation due to the highway construction will be the responsibility of NCDOT when the utility company has prior rights of way / compensable interest. As stated in the overview, the Design-Build Team shall be responsible for determining cost responsibility / compensable interest. A compensable interest is identified as follows:

- (A) Existing or prior easement rights within the limits of the project, either by recorded right of way or adverse possession (Utility occupying the same location for twenty (20) plus years outside the existing highway rights of way).
- (B) Entities covered under *General Statute 136-27.1 and 136-27.2*. Statute requires the NCDOT to pay the non-betterment cost for certain water, sewer and gas relocations.

The cost in relocating CATV due to the highway construction shall be the responsibility of the CATV Company; however, under the following conditions the NCDOT will bear the relocation expense:

- (A) If the CATV Company can validate a recorded easement for facilities outside the maintained NCDOT rights of way.
- (B) The adjustment is needed on existing utility poles to accommodate for a proposed NCDOT Traffic Management System Fiber Optic Communication Cable Project.

The NCDOT shall not permit CATV to place poles within the highway rights of way but will allow down guys for their facilities within the highway rights of way. Under most circumstances, the CATV Company will continue a joint-use attachment with the local Power and Telephone Company. If the CATV proposed relocation places buried facilities within the highway rights of way then plans and encroachment agreements shall be required by the NCDOT.

- IV.** If the Design-Build Team elects to make arrangements with a utility company to incorporate a new utility installation or relocation as part of the highway construction, the utility work done by the Design-Build Team and the associated costs for the work shall be negotiated and agreed upon between the Design-Build Team and the utility company.

The Design-Build Team shall make arrangements to relocate water or sewer line facilities in which the entities are covered under *General Statute 136-27.1* or occupying a compensable interest. The non-betterment costs associated with this work will be borne by NCDOT and shall be addressed in accordance with Article 104-7 of the Standard Special Provisions, Division One, contained elsewhere in this RFP.

If total property acquisition is unavoidable due to encroachment into wells and / or septic systems, then the Design-Build Team shall investigate and determine if extending water and / or sewer lines to the affected property is cost effective. If the Department concurs with the determination that a utility extension is cost effective, the costs associated with the utility construction shall be addressed in accordance with Article 104-7 of the Standard Special Provisions, Division One, contained elsewhere in this RFP.

If the Design-Build Team is requested, in writing, by an entity to relocate, upgrade or incorporate new water and sewer facilities as part of the highway construction, designs shall be coordinated with the Utility Owner and NCDOT Utility Unit. The associated design and construction costs shall be negotiated and agreed upon between the Design-Build Team and the utility company. The Design-Build Team shall develop designs; prepare all plans for needed agreements and permits; submit permits directly to the agencies and obtain approval from the agencies. The Design-Build Team shall be responsible for all permit fees.

If the Design-Build Team elects to make arrangements with a Governmental Agency or any other utility owner for proposed utility construction, in which the Agency / Utility Owner shall be responsible for the costs of work to be performed by the Design-Build Team, the Design-Build Team shall be responsible for negotiating all costs associated with the proposed construction. Once the Design-Build Team and the Agency / Utility

Owner agree on a plan and a lump sum estimated cost for the utility construction, the Design-Build Team shall be responsible for submitting five (5) sets of 11 x 17 utility construction drawings to the State Utility Agent for further handling. Each set shall include a title sheet, plan sheets, profiles and special provisions if available. Also, a letter from the Agency / Utility Owner agreeing to the plans and lump sum cost must accompany this package. The NCDOT will reimburse the Design-Build Team the estimated lump sum cost under a Supplemental Agreement. The necessary Utility Agreement to the Agency / Utility Owner for reimbursement shall be a two party agreement between the NCDOT and the Agency / Utility Owner; and will be developed and executed by the Department.

- V. The Design-Build Team shall be required to utilize the NCDOT Standard Utility Encroachment Agreements as necessary in relocating utilities. The Encroachment Agreements shall be used under the following conditions:
- (A) If a utility company is not occupying a valid right of way / compensable interest and the proposed relocation will place the relocated utilities within the existing or proposed highway rights of way.
 - (B) For **all** new utility installations within the existing or proposed highway rights of way. This includes all water, sewer and gas lines owned by entities covered under *General Statute 136-27.1 and 136-27.2*.
- VI. The NCDOT State Utility Agent must execute approved agreements on Design-Build highway projects. The Utility Relocation Agreements (Cost Agreement) and encroachment agreements are available from the NCDOT Utility Unit. See Pages 59 and 60 of the *NCDOT Utility Manual on Policies & Procedures for Accommodating Utilities on Highway Rights of Way* for the different types of encroachment agreements available for use.

• **Requirements for attachments to existing and / or proposed structures**

- I. The Design-Build Team shall avoid attachments to structures where feasible. Attachments shall only be considered when other alternatives are cost prohibitive and / or are not feasible due to environmental or geographical features. Attachments shall be prohibited under the following conditions:
- (A) No attachments shall be allowed to a bridge located parallel within the C/A carrying the freeway over streams, other roadways or railroads. (No parallel utility installations within the C/A)
 - (B) No attachments shall be allowed to cored-slab bridges.
 - (C) No attachments shall be allowed to curved bridges.
- II. Attachments to structures, if allowed, shall meet the following criteria:
- (A) No attachments shall be allowed below the bottom of the beams and / or girders.

- (B) Drilling of, or attachments to, beams and / or girders shall not be allowed. Attachments shall only be allowed to the bottom of the bridge deck.
 - (C) For water and sewer force mains, only restrained joint ductile iron pipe shall be allowed.
 - (D) A minimum of 18” of clearance to beams and / or girders shall be maintained if possible.
- III.** Documentation of adverse conditions or cost estimates of all feasible alternatives shall be submitted to the NCDOT State Utility Agent when seeking approval of a structure attachment. Cost estimates shall consider all costs involved with each alternative and impacts to the utility and the highway project as a whole.
- **Preparation for Communication Cables / Electrical Services for Lighting, Signing & ITS Devices:**
 - I.** Prior to establishing the location for new meter poles, the Design-Build Team shall coordinate with the local Power Distribution Company concerning accessibility of E/C Service and safety in maintenance of the meter.
 - II.** Prior to installation, the Design-Build Team shall provide plans for review and approval for all service taps that require a parallel installation within the C/A.

Parallel service installations within C/A shall be buried and located as close to the R/W line as practical. Only due to unusual circumstances will parallel aerial service installations within C/A be allowed. The Design-Build Team shall justify the allowance of parallel aerial service installation and obtain NCDOT approval prior to installation.
 - III.** The Design-Build Team shall be responsible for all coordination activities required for the utility company to provide service taps. The Resident Engineer shall approve all service tap locations prior to the Design-Build Team developing associated designs. The NCDOT will be responsible for construction costs associated with the utility company providing service taps.
 - **Preparation for Adjusting Existing Utilities due to Proposed Traffic Management Systems Fiber Optic Communication Cables:**
 - I.** See Traffic Management and Signal Systems Scope of Work (if included in contract).
 - II.** The Design-Build Team shall be responsible for coordination activities required for the utility company to adjust or relocate existing facilities to accommodate the proposed ITS Communication Cable. The NCDOT will be responsible for utility adjustment or relocation costs associated with the proposed ITS Communication Cable installation.

RIGHT OF WAY SCOPE OF WORK (2-20-06)

The Design-Build Team, shall employ qualified, competent personnel who are currently **approved by the NCDOT Right of Way Branch**, herein after referred to as the Department, to provide all services necessary to perform all appraisal, appraisal review, negotiation and relocation services required for completion of the project in accordance with G.S. 136-28.1 of the General Statutes of North Carolina, as amended, and in accordance with the requirements set forth in the *Uniform Appraisal Standards and General Legal Principles for Highway Right of Way*, the *North Carolina Department of Transportation's Right of Way Manual*, the *North Carolina Department of Transportation's Rules and Regulations for the Use of Right of Way Consultants*, the *Code of Federal Regulations*, and *Chapter 133 of the General Statutes of North Carolina from Section 133-5 through 133-18*, hereby incorporated by reference, including the Uniform Relocation Assistance and Real Property Acquisition Policies Act of 1970, as amended. For a list of firms currently approved, contact Mr. Neal Strickland, in the NCDOT Right of Way Branch, at 919-733-7932, extension 317. The Design-Build Team agrees to perform the services as set forth herein and furnish and deliver to the Department reports accompanied by all documents necessary for the settlement of claims and the recordation of deeds, or necessary for condemnation proceedings covering said properties. The Design-Build Team, acting as an agent on behalf of the State of North Carolina shall provide right of way acquisition services for TIP Project R-2616 in Union County.

- ◆ **The Department has begun the right of way acquisition process. The Design-Build Team shall be responsible for all right of way and easement acquisitions that are not finalized upon award of the contract. For those parcels that the Department has completed the right of way acquisition process, the Design-Build Team shall be responsible for any additional right of way and easement acquisition required by revisions to the Department's proposed design and / or construction. The Final RFP will include a list of parcels that shall be the Design-Build Team's responsibility.**
- ◆ **The Design-Build Team shall make every effort to purchase the right of way for contaminated areas as early as possible (see GeoEnvironmental Scope of Work).**

The Design-Build Team shall carry out the responsibilities as follows:

- ◆ With respect to the payments, costs and fees associated with the acquisition of right of way in this contract, the Department shall be responsible for only direct payments to property owners for negotiated settlements, recording fees, any relocation benefits, and deposits and fees involved in the filing of condemnation and any claims. The Department will assume responsibility for all costs associated with the litigation of condemned claims, including testimony by the appraiser(s). The Design-Build Team shall be responsible for all other acquisition related payments, costs and fees.
- ◆ A Department representative will be available to provide technical guidance on right of way acquisition procedures and to make timely decisions on approving relocation benefits and approving administrative adjustment settlements on behalf of the Department over and above the authority granted to the Department Right of Way Consultant Project Managers.

- ◆ The Design-Build Team shall submit a right of way project tracking report and right of way quality control plan to the Department. The Department standard forms and documents shall be used to the extent possible.
- ◆ The Design-Build Team shall provide a current title certificate for each parcel as of the date of closing or the date of filing of condemnation.
- ◆ The Design-Build Team shall prepare, execute and record documents conveying title to acquired properties to the Department with the Register of Deeds. The Design-Build Team shall deliver all executed and recorded deeds and easements to the Department. For all property purchased in conjunction with the project, title shall be acquired in fee simple or easement and shall be conveyed to “The North Carolina Department of Transportation”, free and clear of all liens and encumbrances except permitted encumbrances.
- ◆ It is understood and agreed by and between the parties hereto that all reports, surveys, studies, specifications, memoranda, estimates, etc., secured by and for the Design-Build Team shall become and remain the sole property of the Department upon termination or completion of the work, and the Department shall have the right to use same for any public purpose without compensation to the Design-Build Team.
- ◆ The Design-Build Team shall prepare appraisals in accordance with the Department’s *Uniform Appraisal Standards and General Legal Principles for Highway Right of Way Acquisitions*. The Design-Build Team’s appraiser must be on the Department’s approved state certified appraiser list. The Design-Build Team may request its state certified appraiser be added to the approved state certified appraiser list, subject to approval by the Department’s State Appraiser.
- ◆ The Design-Build Team shall provide appraisal reviews complying with the Department’s *Uniform Appraisal Standards and General Legal Principles for Highway Right of Way Acquisitions*. The reviewer must determine that the appraisal meets the Department’s guideline and requirements, conforms to acceptable appraisal standards and techniques, does not include any non-compensible items or exclude any compensible items and that the value conclusions are reasonable and based on facts presented in the appraisal. The reviewer has the authority to approve, adjust, request additional data or corrections, or not to recommend and request another appraisal. The reviewer has the authority to approve appraisals not in excess of \$750,000.00. All appraisals showing compensation in excess of \$750,000.00 are referred to the Department’s State Appraiser for approval, with the written recommendation of the reviewer. The Design-Build Team’s reviewer must be on the Department’s approved state certified reviewer appraiser list. The Design-Build Team may request its state certified review appraiser to be added to the approved state certified reviewer appraiser list, subject to approval by the Department’s State Appraiser.
- ◆ The Design-Build Team shall provide a right of way certification prior to entering the property.

PUBLIC INFORMATION SCOPE OF WORK (2-27-06)

NCDOT will take the lead role on this project and be responsible for a portion of the public information efforts through the Construction Unit's IMPACT team. The NCDOT responsibilities include:

- Organizing public meetings
- Providing media announcements
- Developing and producing informational print materials
- Soliciting and administering advertisements, as deemed necessary
- Mailings to the identified target audiences, including information development and postage.

The Design-Build Team shall coordinate with the Department to promote public awareness for this project. The Design-Build Team's responsibilities shall include:

- Providing details surrounding the impacts to the public
- Providing advance notice to the Department of upcoming project impacts
- Assisting the Department in the development of the target audience list
- Attending and/or speaking at public meetings
- Hand delivery of time sensitive informational materials.

The Design-Build Team shall hold an initial project coordination meeting with NCDOT one month prior to start of construction to discuss project impacts to the public. This information will be used by the Department to create a Public Information Plan.

The Design-Build Team shall inform the Department at least 3 weeks in advance of any construction activity that will have significant impact on the public, including the start of construction, major traffic shifts, road closures, ramp closures, detours, night work and project completion.

NCDOT will develop, with the assistance of the Design-Build Team, the specific list of target audiences for this project. The following groups are identified as typical target audiences to receive informational materials:

- Governmental agencies
- Municipalities directly affected by construction
- Transportation services
- Emergency services
- Neighborhood groups and private homes
- Industry and businesses
- Chamber of Commerce
- Individual schools effected by the project
- County/City school systems
- Any other organization as deemed necessary by the Department.

The amount of public involvement required for this project is directly based on the Design-Build Team's Traffic Control Plan and construction details. As a minimum, the Design-Build Team shall be responsible for the following involvement:

- Public Meetings – If Beginning of Construction meeting for area businesses and residents is held, attending and / or speaking at this event.
- Distribution of Informational Materials - For beginning of construction and for all road/ramp closures with detour routes, the Design-Build Team shall be responsible for delivering time sensitive informational material provided by the NCDOT directly to portions of the target audience. Distribution responsibilities shall include all resources necessary to hand deliver the informational materials to the affected target audiences.

The Design-Build Team shall include in their Lump Sum Bid price for the project, all costs associated with their involvement in Public Information scope of work.

A web site is not required for this project. However, if the Design-Build Team proposes a project web site, all web site development must use the current NCDOT construction project web design template and must adhere to current software development, security and technical infrastructure standards. All web site design and implementation shall be coordinated with Mr. Ryan Nolan, Internet Web Content Manager, NCDOT Emerging Technologies. The Design-Build Team shall indicate in their Technical Proposal their intent to utilize a web site for this project. All costs associated with setting up and maintaining this website shall be included in the lump sum bid for this project.

***** STANDARD SPECIAL PROVISIONS *******PROMPT PAYMENT OF MONIES DUE SUBCONTRACTORS, SECOND TIER SUBCONTRACTORS AND MATERIAL SUPPLIERS AND RELEASE OF RETAINAGE**

The Design-Build Team, subcontractor, or second tier contractor, shall within seven calendar days of receipt of monies, resulting from work performed on the project or services rendered, pay subcontractors, second tier subcontractors, or material suppliers, as appropriate. This seven-day period begins upon knowledgeable receipt by the contracting firm obligated to make a subsequent periodic or final payment. These prompt payment requirements will be met if each firm mails the payment to the next level firm by evidence of postmark within the seven-day period.

This provision for prompt payment shall be incorporated into each subcontract or second tier subcontract issued for work performed on the project or for services provided.

The Design-Build Team may withhold up to 3% retainage if any subcontractor does not obtain a payment and performance bond for their portion of the work. If any retainage is held on subcontractors, all retainage shall be released within seven calendar days of satisfactory completion of all work. For the purpose of release of retainage, satisfactory completion is defined as completion of all physical elements and corresponding documentation as defined in the contract, as well as agreement between the parties as to the final quantities for all work performed in the subcontract. The Department will provide internal controls to expedite the determination and processing of the final quantities for the satisfactorily completed subcontract portions of the project.

Failure of any entity to make prompt payment as defined herein may result in (1) withholding of money due to that entity in the next partial payment until such assurances are made satisfactory to this provision; or (2) removal of an approved Design-Build Team from the prequalified bidders list or the removal of other entities from the approved subcontractors list.

DB1 G73

BORROW AND WASTE SITE RECLAMATION PROCEDURES (9/6/05)

The Department's Borrow and Waste Site Reclamation Procedures for Contracted Projects have been revised and are available on the website at:

<http://www.ncdot.org/doh/construction/ps/contracts/borrowwastesite20jan05.doc>

In accordance with Article 230-4 and Section 802 of the *Standard Specifications*, the Design-Build Team shall utilize these revised procedures for all borrow and waste sites on this project.

DB1 G120

PLANT AND PEST QUARANTINES (3-18-03)**(Imported Fire Ant, Gypsy Moth, Witchweed, And Other Noxious Weeds)****Within Quarantined Area**

This project may be within a county regulated for plant and/or pests. If the project or any part of the Design-Build Team's operations is located within a quarantined area, thoroughly clean all equipment prior to moving out of the quarantined area. Comply with federal/state regulations by

obtaining a certificate or limited permit for any regulated article moving from the quarantined area.

Originating in a Quarantined County

Obtain a certificate or limited permit issued by the N.C. Department of Agriculture/United States Department of Agriculture. Have the certificate or limited permit accompany the article when it arrives at the project site.

Contact

Contact the N.C. Department of Agriculture/United States Department of Agriculture at 1-800-206-9333, 919-733-6932, or <http://www.ncagr.com/plantind/> to determine those specific project sites located in the quarantined area or for any regulated article used on this project originating in a quarantined county.

Regulated Articles Include

1. Soil, sand, gravel, compost, peat, humus, muck, and decomposed manure, separately or with other articles. This includes movement of articles listed above that may be associated with cut/waste, ditch pulling, and shoulder cutting.
2. Plants with roots including grass sod.
3. Plant crowns and roots.
4. Bulbs, corms, rhizomes, and tubers of ornamental plants.
5. Hay, straw, fodder, and plant litter of any kind.
6. Clearing and grubbing debris.
7. Used agricultural cultivating and harvesting equipment.
8. Used earth-moving equipment.
9. Any other products, articles, or means of conveyance, of any character, if determined by an inspector to present a hazard of spreading imported fire ant, gypsy moth, witchweed or other noxious weeds.

DB1 G130

ROADWAY EXCAVATION (10-4-05)

Revise the *2002 Standard Specifications* as follows:

Page 2-8, delete Article 225-2 and replace with the following:

Erosion Control Requirements

Install erosion control measures as required by the plans prior to any kind of land-disturbing activity.

1. Unless otherwise required by the plans, conduct operations in such a manner that cut and fill slopes are completely graded to final slopes in a continuous operation, and permanently seeded and mulched in accordance with the requirements of the Specifications.
2. Should the Design-Build Team fail to comply with the requirements specified in No. 1 above within the time frames established by the *Sedimentation and Pollution Control Act*, the Design-Build Team shall perform temporary seeding and mulching on any exposed areas at his own expense.

3. When the Design-Build Team fails or neglects to coordinate grading with the permanent seeding and mulching operation, the Engineer may suspend the Design-Build Team's grading operation, in accordance with the provisions of Article 108-7 of the Standard Special Provisions, Division 1 (found elsewhere in this proposal), until the work is coordinated in a manner acceptable to the Engineer. Failure to perform the directed work may result in the Engineer having the work performed in accordance with Article 105-16.

DB2 R25

BORROW EXCAVATION - (Evaluation of Wetlands) (2-19-02)

Revise the 2002 Standard Specifications as follows:

Page 2-20, Article 230-6

After the first paragraph, insert the following paragraph:

"No separate payment will be made for the work of Evaluation of Potential Wetlands and Endangered Species as outlined above. Payment at the contract lump sum price for Construction of the Design Build project will be considered full compensation for this work.

DB2 R37

PREPARATION OF SUBGRADE AND BASE (1-16-96)

On mainline portions and ramps of this project, prepare the subgrade and base beneath the pavement structure in accordance with the applicable sections of the Standard Specifications except use an automatically controlled fine grading machine utilizing string lines, laser controls, or other approved methods to produce final subgrade and base surfaces meeting the lines, grades, and cross sections required by the plans or established by the Engineer.

DB5 R05

ASPHALT PAVEMENTS – SUPERPAVE (7/11/05)

Revise the 2002 *Standard Specifications* as follows:

ASPHALT TACK COAT

Page 6-4, Article 605-8

Insert the following after paragraph one in this Article:

Take necessary precautions to limit the tracking and/or accumulation of tack coat material on either existing or newly constructed pavements. Excessive accumulation of tack may require corrective measures.

FIELD VERIFICATION AND JOB MIX FORMULA ADJUSTMENTS

Page 6-7, Article 609-4

Delete the first paragraph under this Article and substitute the following:

Conduct field verification of the mix at each plant within 30 calendar days prior to initial production of each mix design, when required by the Allowable Mix Adjustment Policy and when directed as deemed necessary.

Page 6-8, Article 609-4

Delete the first paragraph on this page and substitute the following:

Retain records of these calibrations and mix verification tests, including Superpave Gyrotory Compactor (SGC) printouts, at the QC laboratory. In addition, furnish copies, including SGC printouts, to the Engineer for review and approval within one working day after beginning production of the mix.

Page 6-8, Article 609-4

Add the following sentence to the end of the last paragraph in this Article:

Any mix produced that is not verified may be assessed a price reduction at the Engineer's discretion in addition to any reduction in pay due to mix and/or density deficiencies.

Quality control minimum sampling and testing schedule:

Page 6-9, Subarticle 609-5(C)1

Add the following sentence to the end of the first paragraph in this Article:

Any additional QC samples taken and tested shall be identified as process control (PC) samples on the appropriate forms but are not required to be reported to the QA Laboratory.

Page 6-9, Subarticle 609-5(C)1

Delete the second sentence in the second paragraph of this Article and substitute the following:

Retain the QC compacted volumetric test specimens for 5 calendar days, commencing the day the specimens are prepared.

Page 6-9, Subarticle 609-5(C)2

At the bottom of this page, delete the sentence directly above the Accumulative Production Increment and substitute the following:

Sample and test the completed mixture from each mix design at the following minimum frequency during mix production:

Page 6-10, Subarticle 609-5(C)2

Revise Items B, C, D and E on this page as follows:

- B. Gradation on Recovered Blended Aggregate from Mix Sample (AASHTO T 30 Modified) Grade on all sieves specified on JMF
- C. Maximum Specific Gravity (AASHTO T 209), optional (ASTM D 6857)
- D. Bulk Specific Gravity of Compacted Specimens (AASHTO T166), optional (ASTM D 6752), Average of 3 specimens at N_{des} gyrations (AASHTO T 312)
- E. Air Voids (VTM) (AASHTO T 269), Average of 3 specimens at N_{des} gyrations

Page 6-11, Subarticle 609-5(C)2

At the top of this page, delete Item B., "Reclaimed Asphalt Pavement..." and substitute the following:

- B. Reclaimed Asphalt Pavement (RAP) Binder Content and Gradation (AASHTO T 308 Modified or T 164 and AASHTO T 30 Modified) (sampled from stockpiles or cold feed system at beginning of production and weekly thereafter). Have RAP approved for use in accordance with Article 1012-1(G). (Split Sample Required)

Page 6-11, Subarticle 609-5(C)2

Insert the following sampling and testing at the end of this Subarticle

Uncompacted Void Content of Fine Aggregate, AASHTO T 304, Method A (natural sand only). Performed at Mix Design and when directed as deemed necessary. (Split Sample Required)

Reclaimed Asphalt Shingle Material (RAS) Binder Content and Gradation (AASHTO T 308 Modified or T 164 and AASHTO T 30 Modified) (sampled from stockpiles or cold feed system at beginning of production and weekly thereafter). Have RAS approved for use in accordance with Article 1012-1(F). (Split Sample Required)

CONTROL CHARTS

Page 6-11, Subarticle 609-5(C)3

Delete the second sentence of the first paragraph in this Subarticle and substitute the following:

For mix incorporated into the project, record full test series data from all regularly scheduled random samples or directed samples which replace regularly scheduled random samples, on control charts the same day the tests are obtained. In addition, partial test series results obtained due to reasons outlined in Subarticle 609-5(C)2 will be reported to Quality Assurance personnel on the proper forms, but will not be plotted on the control charts.

Page 6-12, Subarticle 609-5(C)3

Delete item 3 in the list below the second full paragraph on this page.

CONTROL LIMITS

Page 6-12, Subarticle 609-5(C) 4

At the bottom of this page, delete the table and substitute the following:

CONTROL LIMITS

Mix Control Criteria	Target Source	Warning Limit	Moving Average Limit	Individual Limit
2.36mm Sieve	JMF	±4.0 %	±5.0 %	±8.0 %
0.075mm Sieve	JMF	±1.5 %	±2.0 %	±2.5 %
Binder Content	JMF	±0.3 %	±0.5 %	±0.7 %
VTM @ N _{des}	JMF	±1.0 %	±1.5 %	±2.0 %
VMA @ N _{des}	Min. Spec. Limit	-0.5%	-0.8%	-1.0%
P _{0.075} / P _{be} Ratio	Max. Spec. Limit	0.0	N/A	+0.4%
%G _{mm} @ N _{ini}	Max. Spec. Limit	N/A	N/A	+2.0%
TSR	Min. Spec. Limit	N/A	N/A	-15.0%

FIELD COMPACTION QUALITY CONTROL

Page 6-15, Subarticle 609-5(D)1

Delete the first and second sentences in the fourth paragraph on this page and substitute the following:

Base and intermediate mix types (surface mixes not included) utilized for pavement widening of less than 4.0 feet and all mix types used in tapers, irregular areas and intersections (excluding full width travel lanes of uniform thickness), will not be subject to the sampling and testing frequency specified above provided the pavement is compacted using approved equipment and procedures. However, the Engineer may require occasional density sampling and testing to evaluate the compaction process.

Page 6-16, Subarticle 609-5(D)1

Delete item number 2 at the top of this page. Item number 3 should be re-numbered as 2 after the specified deletion.

Page 6-16, Subarticle 609-5(D)2

Delete the second sentence in the first paragraph of the Subarticle and add the following sentence to the end of the paragraph:

The use of a separator medium beneath the layer to be tested is prohibited.

LIMITED PRODUCTION PROCEDURE

Page 6-17, Subarticle 609-5(D) 5

Delete the first paragraph in this Subarticle and substitute the following:

Proceed on limited production when, for the same mix type, one of the following items occur:

Two consecutive failing lots, excluding lots representing an individual resurfacing map or portion thereof.

Three consecutive failing lots, with each lot representing an individual resurfacing map or portion thereof.

Two consecutive failing nuclear control strips.

Pavement within each construction category (New and Other), as defined in Article 610-13, and pavement placed simultaneously by multiple paving crews will be evaluated independently for limited production purposes.

Delete the first sentence in the last paragraph in this Subarticle and substitute the following:

If the Design-Build Team does not operate by the limited production procedures as specified above, the two consecutive failing density lots, three consecutive failing lots with each lot representing an individual resurfacing map or portion thereof, or two consecutive failing nuclear control strips, whichever is applicable, and all mix produced thereafter will be considered unacceptable. Remove this material and replace with material which complies with the Specifications, unless otherwise approved.

DOCUMENTATION (RECORDS)

Page 6-18, Subarticle 609-5(E)

Add the following sentence to the end of the first paragraph in this Subarticle:

Process control sample test results are for the Design-Build Team's informational purposes only.

Page 6-18, Subarticle 609-5(E)

Delete the third and fourth sentence in the first full paragraph on this page and substitute the following:

Maintain all QC records, forms and equipment calibrations for a minimum of 3 years from their completion date.

Delete the second full paragraph on this page and substitute the following:

Falsification of test results, documentation of observations, records of inspection, adjustments to the process, discarding of samples and/or test results, or any other deliberate misrepresentation of the facts will result in the revocation of the applicable person's QMS certification. The Engineer will determine acceptability of the mix and/or pavement represented by the falsified results or documentation. If the mix and/or pavement in question is determined to be acceptable, the Engineer may allow the mix to remain in place at no pay for the mix, asphalt binder and other mix components. If the mix and/or pavement represented by the falsified results is determined not to be acceptable, remove and replace with mix, which complies with the Specifications. Payment will be made for the actual quantities of materials required to replace the falsified quantities, not to exceed the original amounts.

QUALITY ASSURANCE

Page 6-18, Article 609-6

In Item 1 under Plant Mix Quality Assurance, substitute "5%" for "10%".

In Item 5 under Plant Mix Quality Assurance, add "at a frequency equal to or greater than 10% of the QC sample frequency".

In the first sentence within the paragraph below Plant Mix Quality Assurance, delete the words "of mix".

In Item 1 under Density Quality Assurance, delete the wording at the end of the sentence "at a frequency equal to or greater than 10% of the frequency required of the Contractor".

Page 6-19, Article 609-6

In Item 4 under Density Quality Assurance, add "at a frequency equal to or greater than 5% of the QC sample frequency."

Insert the following after Item 4 under Density Quality Assurance:

5. By periodically directing the recalculation of random numbers for the Quality Control core or nuclear density test locations. The original QC test locations may be tested by QA and evaluated as verification tests.

LIMITS OF PRECISION

Page 6-19, Article 609-6

In the limits of precision table, delete the last three rows and substitute the following:

QA retest of prepared QC Gyrotory Compacted Volumetric Specimens	± 0.015
Retest of QC Core Sample	$\pm 1.2\%$ (% Compaction)
Comparison of QA Core Sample	$\pm 2.0\%$ (% Compaction)
QA Verification Core Sample	$\pm 2.0\%$ (% Compaction)
Nuclear Comparison of QC Test	$\pm 2.0\%$ (% Compaction)
QA Nuclear Verification Test	$\pm 2.0\%$ (% Compaction)

ASPHALT CONCRETE PLANT MIX PAVEMENTS – DESCRIPTION

Page 6-20, Article 610-1

Insert the following after the last paragraph in this Article:

A high frequency of asphalt plant mix, density, or mix and density deficiencies occurring over an extended duration of time may result in future asphalt, which is represented by mix and/or density test results not in compliance with minimum specification requirements, being excluded from acceptance at an adjusted contract unit price in accordance with Article 105-3. This acceptance process may apply to all asphalt produced and /or placed and may continue until the Engineer determines a history of quality asphalt production and placement is reestablished.

MATERIALS

Page 6-21, Article 610-2

Delete reference of Anti-strip additive (chemical) to Article 1020-2 and substitute Article 1020-8.

COMPOSITION OF MIXTURES (MIX DESIGN AND JOB MIX FORMULA)

Page 6-21, Subarticle 610-3(A)

At the end of the second paragraph under this Subarticle, add the following sentence:

In addition, submit Superpave gyratory compactor printouts for all specimens compacted at N_{des} and N_{max} during the mix design process.

Insert the following paragraph after the second paragraph under this Subarticle:

For the final surface layer of the specified mix type, use a mix design with an aggregate blend gradation above the maximum density line on the 2.36 mm and larger sieves.

Insert the following at the end of the third paragraph under this Article:

When the percent of binder contributed from RAS or a combination of RAS and RAP exceeds 20 percent of the total binder in the completed mix, the virgin binder PG grade must be one grade below (both high and low temperature grade) the binder grade specified in Table 610-2 for the mix type.

Delete the fourth paragraph in this Subarticle and substitute the following:

For Type S 12.5D mixes, the maximum percentage of reclaimed asphalt material is limited to 15% and must be produced using virgin asphalt binder grade PG 76-22. For all other recycled mix types, when the percentage of RAP is 15 percent or less of the total mixture, the virgin binder PG grade must be as specified in Table 610-2 for the specified mix type. When the percentage of RAP is greater than 15 but not more than 25 percent of the total mixture, the virgin binder PG grade must be one grade below (both high and low temperature grade) the specified grade for the mix type. When the percentage of RAP is greater than 25 percent of the total mixture, the Engineer will establish and approve the asphalt binder grade.

Page 6-22, Subarticle 610-3(A)

Insert the following sentence at the end of the Item 4:

If natural sand is utilized in the proposed mix design, determine and report the Uncompacted Void Content of the natural sand in accordance with AASHTO T-304, Method A.

Page 6-23, Subarticle 610-3(A)

Under the quantities of mix components insert the following sentence:

When requested by the Engineer, submit to the Department's Materials and Tests Unit, in Raleigh, six (6) Superpave Gyrotory Compactor specimens compacted to a height of 75 mm and to a void content (VTM) of 4.0% +/- 0.5% for performance rut testing with the Asphalt Pavement Analyzer.

JOB MIX FORMULA

Page 6-24, Subarticle 610-3(C)

Delete Table 610-1 and associated notes. Substitute the following:

**TABLE 610-1
SUPERPAVE AGGREGATE GRADATION DESIGN CRITERIA**

Standard Sieves	Percent Passing Criteria (Control Points)											
	Mix Type (Nominal Maximum Aggregate Size)											
	4.75 mm (a)		9.5 mm (c)		12.5 mm (c)		19.0 mm		25.0 mm		37.5 mm	
(mm)	Min.	Max.	Min.	Max.	Min.	Max.	Min.	Max.	Min.	Max.	Min.	Max.
50.0											100.0	
37.5									100.0		90.0	100.0
25.0							100.0		90.0	100.0		90.0
19.0					100.0		90.0	100.0		90.0		
12.5			100.0		90.0	100.0		90.0				
9.5	100.0		90.0	100.0		90.0						
4.75	90.0	100.0		90.0								
2.36	65.0	90.0	32.0(b)	67.0(b)	28.0	58.0	23.0	49.0	19.0	45.0	15.0	41.0
1.18												
0.600												
0.300												
0.150												
0.075	4.0	8.0	4.0	8.0	4.0	8.0	3.0	8.0	3.0	7.0	3.0	6.0

For Type S 4.75A, a minimum of 50% of the aggregate components shall be manufactured material from the crushing of stone.

For Type SF 9.5A, the percent passing the 2.36mm sieve shall be a minimum of 60% and a maximum of 70%.

For the final surface layer of the specified mix type, use a mix design with an aggregate blend gradation above the maximum density line on the 2.36 mm and larger sieves.

Page 6-25, Subarticle 610-3(C),

Delete Table 610-2 and associated notes. Substitute the following:

**TABLE 610-2
SUPERPAVE MIX DESIGN CRITERIA**

	Design	Binder	Compaction Levels			Volumetric Properties (c)				
Mix	ESALs	PG								
Type	millions	Grade	No. Gyration @			VMA	VTM	VFA	%Gmm	
(f)	(a)	(b)	N _{ini}	N _{des}	N _{max}	% Min.	%	Min. - Max.	@ N _{ini}	
S-4.75A	<0.3	64 -22	6	50	75	20.0	7.0-15.0			
SF-9.5A	<0.3	64 -22	6	50	75	16.0	3.0 - 5.0	70 - 80	≤ 91.5	
S-9.5B	0.3 - 3	64 -22	7	75	115	15.0	3.0 - 5.0	65 - 80	≤ 90.5	
S-9.5C	3 - 30	70 -22	8	100	160	15.0	3.0 - 5.0	65 - 76	≤ 90.0	
S-9.5D	> 30	76 -22	9	125	205	15.0	3.0 - 5.0	65 - 76	≤ 90.0	
S-12.5C	3 - 30	70 -22	8	100	160	14.0	3.0 - 5.0	65 - 75	≤ 90.0	
S-12.5D	> 30	76 -22	9	125	205	14.0	3.0 - 5.0	65 - 75	≤ 90.0	
I-19.0B	< 3	64 -22	7	75	115	13.0	3.0 - 5.0	65 - 78	≤ 90.5	
I-19.0C	3 - 30	64 -22	8	100	160	13.0	3.0 - 5.0	65 - 75	≤ 90.0	
I-19.0D	> 30	70 -22	9	125	205	13.0	3.0 - 5.0	65 - 75	≤ 90.0	
B-25.0B	< 3	64 -22	7	75	115	12.0	3.0 - 5.0	65 - 78	≤ 90.5	
B-25.0C	> 3	64 -22	8	100	160	12.0	3.0 - 5.0	65 - 75	≤ 90.0	
B-37.5C	> 3	64 -22	8	100	160	11.0	3.0 - 5.0	63 - 75	≤ 90.0	
	Design Parameter						Design Criteria			
All	1. %G _{mm} @ N _{max}						≤ 98.0% (d)			
Mix	2. Dust to Binder Ratio (P _{0.075} / P _{be})						0.6 - 1.4			
Types	3. Retained Tensile Strength (TSR) (AASHTO T 283 Modified)						85 % Min. (e)			

- Notes: (a) Based on 20 year design traffic.
 (b) When Recycled Mixes are used, select the binder grade to be added in accordance with Subarticle 610-3(A).
 (c) Volumetric Properties based on specimens compacted to N_{des} as modified by the Department.
 (d) Based on specimens compacted to N_{max} at selected optimum asphalt content.
 (e) AASHTO T 283 Modified (No Freeze-Thaw cycle required). TSR for Type S 4.75A, Type B 25.0 and Type B 37.5 mixes is 80% minimum.

Mix Design Criteria for Type S 4.75A may be modified subject to the approval of the Engineer

WEATHER, TEMPERATURE, AND SEASONAL LIMITATIONS FOR PRODUCING AND PLACING ASPHALT MIXTURES

Page 6-26, Article 610-4, Table 610-3

Delete the title of Table 610-3 and substitute the following title:

ASPHALT PLACEMENT- MINIMUM TEMPERATURE REQUIREMENTS

In the first column, third row; delete reference to the ACSC Types S 9.5A and S 12.5B mix.

Add the following minimum placing temperatures for mix types S 4.75A and SF 9.5A.

Asphalt Concrete Mix Type	Minimum Air Temperature	Minimum Road Surface Temperature
ACSC, Type S 4.75A, SF 9.5A, S9.5B	40°F (5°C)	50°F (10°C)

SPREADING AND FINISHING

Page 6-32, Article 610-8

Insert the following after the second sentence within the sixth paragraph in this Article,

Do not allow the paver hopper to become empty between loads. Take necessary precautions during production, loading of trucks, transportation, truck exchanges with paver, folding of the paver hopper wings, and conveying material in front of the screed to prevent segregation of the asphalt mixtures.

Page 6-33, Article 610-8

At the end of the third full paragraph on this page, add the following sentence:

Waiver of the use of automatic screed controls does not relieve the Design-Build Team of achieving plan grades and cross-slopes.

Page 6-33, Article 610-8

Insert the following at the end of this Article:

Use a Material Transfer Vehicle (MTV) when placing all asphalt concrete plant mix pavements, including open-graded asphalt friction course, which require the use of asphalt binder grade PG 76-22, unless otherwise approved. Utilize the MTV when placing all full width travel lanes, including shoulders, collector lanes, ramps, and loops which require PG 76-22.

Provide an MTV that receives mixture from the hauling equipment and independently delivers the mixture from the hauling equipment to the paving equipment. Provide an MTV capable of transferring the material from the haul vehicle to the paver hopper at a uniform and continuous rate to allow the continuous movement of the paver. Install a paver hopper insert with a minimum capacity of 7 tons (6.25 metric tons) in the hopper of conventional paving equipment when utilizing a MTV. Perform remixing of the material prior to discharge into the paver conveyor system by utilizing either a MTV with a remixing system contained within a minimum

7 ton (6.25 metric tons) capacity storage bin or a dual pugmill system with two full length transversely mounted paddle mixers located in the paver hopper insert.

Use an MTV that provides to the paver a homogeneous, non-segregated mixture that is of uniform temperature such that there is no more than 20°F (11°C) difference between the highest and lowest temperatures when measured transversely across the width of the mat in a straight line at a distance of one foot (0.3 m) to three feet (0.9 m) from the screed while the paver is operating. Obtain the temperature measurements approximately one foot (0.3 m) from each edge and at least once in the middle of the mat.

Empty the MTV when crossing a bridge and move across without any other vehicles or equipment being on the bridge. Move the MTV across a bridge in a travel lane and not on the shoulder. While crossing a bridge move the MTV at a speed no greater than five miles per hour (8 km per hour) without any abrupt acceleration or deceleration.

In the event the MTV malfunctions during paving operations, immediately discontinue plant operations and do not resume operations until the MTV malfunctions have been remedied, unless otherwise directed due to safety concerns. The Design-Build Team may continue placement of the mix until any additional mix in transit has been placed, provided satisfactory results are achieved. This procedure in no way alleviates the Design-Build from meeting contract requirements.

DENSITY REQUIREMENTS

Page 6-34, Article 610-10,

Delete Table 610-4 and substitute the following table and associated notes:

**Table 610-4
MINIMUM DENSITY REQUIREMENTS**

MIX TYPE	MINIMUM % of G _{mm}
SUPERPAVE MIXES	(Maximum Specific Gravity)
S 4.75A	85.0 ^(a,b)
SF 9.5A	90.0
S 9.5X, S 12.5X, I 19.0X, B 25.0X, B 37.5X	92.0

All S 4.75A pavement will be accepted for density in accordance with Article 105-3

Compaction to the above specified density will be required when the S 4.75 A mix is applied at a rate of 100 lbs/sy (55 kg/m²)

Page 6-34, Article 610-10

Delete the second paragraph in this Article and substitute the following:

Compact base and intermediate mix types (surface mixes not included) utilized for pavement widening of less than 4.0 feet (1.2 meters) and all mix types used in tapers, irregular areas and intersections (excluding full width travel lanes of uniform thickness), using equipment and procedures appropriate for the pavement area width and/or shape. Compaction with equipment other than conventional steel drum rollers may be necessary to achieve adequate compaction. Occasional density sampling and testing to evaluate the compaction process may be required.

Densities lower than that specified in Table 610-4 will be accepted, in accordance with Article 105-3, for the specific mix types and areas listed directly above.

SURFACE REQUIREMENTS AND ACCEPTANCE

Page 6-35, Article 610-12

Delete the first paragraph in this Article and substitute the following:

Construct pavements using quality paving practices as detailed herein. Construct the pavement surface smooth and true to the plan grade and cross slope. Immediately correct any defective areas with satisfactory material compacted to conform with the surrounding area. Pavement imperfections resulting from unsatisfactory workmanship such as segregation, improper longitudinal joint placement or alignment. Non-uniform edge alignment and excessive pavement repairs will be considered unsatisfactory and if allowed to remain in place will be accepted in accordance with Article 105-3.

When directed due to unsatisfactory laydown or workmanship, operate under the limited production procedures. Limited production for unsatisfactory laydown is defined as being restricted to the production, placement, compaction, and final surface testing (if applicable) of a sufficient quantity of mix necessary to construct only 2500 feet (750 meter) of pavement at the laydown width.

Remain on limited production until such time as satisfactory laydown results are obtained or until three consecutive 2500 foot (750 meter) sections have been attempted without achieving satisfactory laydown results. If the Design-Build Team fails to achieve satisfactory laydown results after three consecutive 2500 foot (750 meter) sections have been attempted, cease production of that mix type until such time as the cause of the unsatisfactory laydown results can be determined. As an exception, the Engineer may grant approval to produce a different mix design of the same mix type if the cause is related to mix problem(s) rather than laydown procedures.

Mix placed under the limited production procedures for unsatisfactory laydown or workmanship will be evaluated for acceptance in accordance with Article 105-3.

DENSITY ACCEPTANCE

Page 6-36, Article 610-13

Delete the second paragraph on this page and substitute the following:

The pavement will be accepted for density on a lot by lot basis. A lot will consist of one day's production of a given job mix formula on a contract. As an exception, separate lots will be established when the one of the following occurs:

Portions of pavement are placed in both "New" and "Other" construction categories as defined below. A lot will be established for the portion of the pavement in the "New" construction category and a separate lot for the portion of pavement in the "Other" construction category.

Pavement is placed on multiple resurfacing maps, unless otherwise approved prior to paving. A lot will be established for each individual resurfacing map or portion thereof.

Pavement is placed simultaneously by multiple paving crews. A lot will be established for the pavement placed by each paving crew.

Pavement is placed in different layers. A lot will be established for each layer.

Control strips are placed during limited production.

The Engineer will determine the final category and quantity of each lot for acceptance purposes.

Page 6-36, Article 610-13

Delete the first sentence in the third paragraph on this page and insert the following:

The “New” construction category will be defined as pavements of uniform thickness, exclusive of irregular areas, meeting all three of the following criteria:

Delete the sixth paragraph in this Article and substitute the following:

A failing lot for density acceptance purposes is defined as a lot for which the average of all test sections, and portions thereof, fails to meet the minimum specification requirement. If additional density sampling and testing, beyond the minimum requirement, is performed and additional test sections are thereby created, then all test results shall be included in the lot average. In addition, any lot or portion of a lot that is obviously unacceptable will be rejected for use in the work.

Page 6-36, Article 610-13

Delete the last paragraph on this page and substitute the following:

Any density lot not meeting minimum density requirements detailed in Table 610-4 will be evaluated for acceptance by the Engineer. If the lot is determined to be reasonably acceptable, the mix will be paid at an adjusted contract price in accordance with Article 105-3. If the lot is determined not to be acceptable, the mix will be removed and replaced with mix meeting and compacted to the requirement of these specifications.

CONSTRUCTION REQUIREMENTS

Page 6-43, Article 650-5

Add the following paragraph after the first paragraph under this Article:

Do not place open-graded asphalt friction course between October 31 and April 1 of the next year, unless otherwise approved. Place friction course, Type FC-1 mixes, only when the road surface temperature is 50°F (10°C) or higher and the air temperature is 50°F (10°C) or higher. The minimum air temperature for Type FC-1 Modified and FC-2 Modified mixes will be 60°F (15°C).

AGGREGATES FOR ASPHALT PLANT MIXES

Page 10-34, Subarticle 1012-1(B)4

Delete this Subarticle and substitute the following:

Flat and Elongated Pieces:

Use coarse aggregate meeting the requirements of Table 1012-1 for flat and elongated pieces when tested in accordance with ASTM D 4791 (Section 8.4) on the No. 4 (4.75 mm) sieve and

larger with a 5:1 aspect ratio (maximum to minimum) for all pavement types, except there is no requirement for Types S 4.75A, SF 9.5A, and S 9.5B.

Page 10-35, Table 1012-1

Delete Table 1012-1 and substitute the following:

Table 1012-1
AGGREGATE CONSENSUS PROPERTIES^(a)

Mix Type	Course	Fine	Sand	Flat &
	Aggregate	Aggregate	Equivalent	Elongated
	Angularity ^(b)	Angularity		5 : 1 Ratio
		% Minimum	% Minimum	% Maximum
	ASTM D 5821	AASHTO T 304 Method A	AASHTO T 176	ASTM D 4791 Section 8.4
S 4.75 A		40	40	
SF 9.5 A S 9.5 B I 19.0 B B 25.0 B	75 / -	40	40	10 ^(c)
S 9.5 C S 12.5 C I 19.0 C B 25.0 C B 37.5 C	95 / 90	45	45	10
S 12.5 D I 19.0 D	100 / 100	45	50	10
OGAFC	100 / 100	N/A	N/A	10

Requirements apply to the course aggregate blend and/or fine aggregate blend
95/90 denotes that 95% of the course aggregate (+No.4 or + 4.75mm sieve)has
one fractured face and 90% has two or more fractured faces.

Does not apply to Mix Types SF 9.5 A or S 9.5 B

Page 10-36, Subarticle 1012-1(C)1

Insert the following after the fourth paragraph on this page:

When natural sand is utilized in “C” or “D” level asphalt mixes, do not exceed the maximum natural sand percentage in the mix design and/or production aggregate blend detailed in Table 1012-1A.

Table 1012-1A

Uncompacted Void Content of Fine Aggregate AASHTO T 304 Method A	Maximum Percent Natural Sand Included in Mix Design and/or Production*
Less than 42.0	10
Equal to 42.0 to 44.9	15
Equal to 45.0 and greater	20

*Maximum percent natural sand may be exceeded with approval from Pavement Construction Engineer upon satisfactory evaluation of pavement performance testing

FINE AGGREGATE ANGULARITY

Page 10-36, Subarticle 1012-1(C)6

Delete reference to AASHTO TP 33 Method A and substitute AASHTO T 304, Method A.

Page 10-37, Subarticle 1012-1(H)

Delete this Subarticle. It is a duplicate of Subarticle 1012-1(F) located on Page 10-36.

ASPHALT BINDER

Page 10-46, Article 1020-2

Delete the first paragraph under this Article and substitute the following:

Use Performance Graded Asphalt Binder meeting the requirements of AASHTO M 320. See Article 610-3 for the specified grades. Submit a Quality Control Plan for asphalt binder production in conformance with the requirements of AASHTO R 26 to the Materials and Tests Unit.

DB6 R01

ASPHALT BINDER CONTENT OF ASPHALT PLANT MIXES (10-6-05)

The approximate asphalt binder content of the asphalt concrete plant mixtures used on this project will be as follows:

Asphalt Concrete Base Course	Type B 25.0X	4.3%
Asphalt Concrete Intermediate Course	Type I 19.0X	4.7%
Asphalt Concrete Surface Course	Type S 4.75A	7.0%
Asphalt Concrete Surface Course	Type SF 9.5A	6.5%
Asphalt Concrete Surface Course	Type S 9.5X	6.0%
Asphalt Concrete Surface Course	Type S 12.5X	5.5%

The actual asphalt binder content will be established during construction by the Engineer within the limits established in *the Standard Specifications* or Project Special Provisions.

DB6 R15

FINAL SURFACE TESTING - ASPHALT PAVEMENTS (2/9/06)

Perform acceptance testing of the longitudinal profile of the finished pavement surface in accordance with these provisions using a North Carolina Hearne Straightedge (Model No. 1). Furnish and operate the straightedge to determine and record the longitudinal profile of the

pavement on a continuous graph. Final surface testing is an integral part of the paving operation and is subject to observation and inspection by the Engineer as deemed necessary.

Push the straightedge manually over the pavement at a speed not exceeding 2 miles per hour (3 kilometers per hour). For all lanes, take profiles in the right wheel path approximately 3 ft (1 m) from the right edge of pavement in the same direction as the paving operation, unless otherwise approved due to traffic control or safety considerations. Make one pass of the straightedge in each full width travel lane. The full lane width should be comparable in ride quality to the area evaluated with the Hearne Straightedge. If deviations exist at other locations across the lane width, utilize a 10 foot non-mobile straightedge or the Hearne Straightedge to evaluate which areas may require corrective action. Take profiles as soon as practical after the pavement has been rolled and compacted but in no event later than 24 hours following placement of the pavement, unless otherwise authorized by the Engineer. Take profiles over the entire length of final surface travel lane pavement exclusive of -Y- line travel lanes less than or equal to 300 feet (90 meters) in length, turn lanes less than or equal to 300 feet (90 meters) in length, structures, approach slabs, paved shoulders, loops, and tapers or other irregular shaped areas of pavement, unless otherwise approved by the Engineer. Test in accordance with this provision all mainline travel lanes, full width acceleration or deceleration lanes, -Y- line travel lanes greater than 300 feet (90 meters) in length, ramps, full width turn lanes greater than 300 feet (90 meters) in length, and collector lanes.

At the beginning and end of each day's testing operations, and at such other times as determined necessary by the Engineer, operate the straightedge over a calibration strip so that the Engineer can verify correct operation of the straightedge. The calibration strip must be a 100 ft (30 m) section of pavement that is reasonably level and smooth. Submit each day's calibration graphs with that day's test section graphs to the Engineer. Calibrate the straightedge in accordance with the current NCDOT procedure titled "North Carolina Hearne Straightedge - Calibration and Determination of Cumulative Straightedge Index". Copies of this procedure may be obtained from the Department's Pavement Construction Section.

Plot the straightedge graph at a horizontal scale of approximately 25 ft per inch (3 m per cm) with the vertical scale plotted at a true scale. Record station numbers and references (bridges, approach slabs, culverts, etc.) on the graphs, and distances between references/stations must not exceed 100 ft (30 m). Have the operator record the Date, Project No., Lane Location, Wheel Path Location, Type Mix, and Operator's Name on the graph.

Upon completion of each day's testing, evaluate the graph, calculate the Cumulative Straightedge Index (CSI), and determine which lots, if any, require corrective action. Document the evaluation of each lot on a QA/QC-7 form. Submit the graphs along with the completed QA/QC-7 forms to the Engineer, within 24 hours after profiles are completed, for verification of the results. The Engineer will furnish results of their acceptance evaluation to the Design-Build Team within 48 hours of receiving the graphs. In the event of discrepancies, the Engineer's evaluation of the graphs will prevail for acceptance purposes. The Engineer will retain all graphs and forms.

Use blanking bands of 0.2 inches, 0.3 inches, and 0.4 inches (5 mm, 7.5 mm, and 10 mm) to evaluate the graph for acceptance. The 0.2 inch and 0.3 inch (5 mm and 7.5 mm) blanking bands are used to determine the Straightedge Index (SEI), which is a number that indicates the deviations that exceed each of the 0.2 inch and 0.3 inch (5 mm and 7.5 mm) bands within

a 100 ft (30 m) test section. The Cumulative Straightedge Index (CSI) is a number representing the total of the SEIs for one lot, which consist of not more than 25 consecutive test sections. In addition, the 0.4 inch (10 mm) blanking band is used to further evaluate deviations on an individual basis. The Cumulative Straightedge Index (CSI) will be determined by the Engineer in accordance with the current procedure titled "North Carolina Hearne Straightedge - Calibration and Determination of Cumulative Straightedge Index".

The pavement will be accepted for surface smoothness on a lot by lot basis. A test section represents pavement one travel lane wide not more than 100 ft (30 m) in length. A lot will consist of 25 consecutive test sections, except that separate lots will be established for each travel lane, unless otherwise approved by the Engineer. In addition, full width acceleration or deceleration lanes, ramps, turn lanes, and collector lanes, will be evaluated as separate lots.

If during the evaluation of the graphs, 5 lots (mainline travel lanes and full width -Y- line travel lanes greater than 300 feet in length only) require corrective action, then proceed on limited production for unsatisfactory laydown in accordance with Article 610-12. Proceeding on limited production is based upon the Design-Build Team's initial evaluation of the straightedge test results and must begin immediately upon obtaining those results. Additionally, the Engineer may direct the Design-Build Team to proceed on limited production in accordance with Article 610-12 due to unsatisfactory laydown or workmanship.

Limited production for unsatisfactory laydown is defined as being restricted to the production, placement, compaction, and final surface testing of a sufficient quantity of mix necessary to construct only 2500 feet (750 meter) of pavement at the laydown width. Once this lot is complete, the final surface testing graphs will be evaluated jointly by the Design-Build Team and the Engineer. Remain on limited production until such time as acceptable laydown results are obtained or until three consecutive 2500 foot (750 meter) sections have been attempted without achieving acceptable laydown results. The Engineer will determine if normal production may resume based upon the CSI for the limited production lot and any adjustments to the equipment, placement methods, and/or personnel performing the work. Once on limited production, the Engineer may require the Design-Build Team to evaluate the smoothness of the previous asphalt layer and take appropriate action to reduce and/or eliminate corrective measures on the final surface course. Additionally, the Design-Build Team may be required to demonstrate acceptable laydown techniques off the project limits prior to proceeding on the project.

If the Design-Build Team fails to achieve acceptable laydown results after three consecutive 2500 foot (750 meter) sections have been attempted, cease production of that mix type until such time as the cause of the unsatisfactory laydown results can be determined.

As an exception, the Engineer may grant approval to produce a different mix design of the same mix type if the cause is related to mix problem(s) rather than laydown procedures. If production of a new mix design is allowed, proceed under the limited production procedures detailed above.

After initially proceeding under limited production, the Design-Build Team shall immediately notify the Engineer if any additional lot on the project requires corrective action. The Engineer will determine if limited production procedures are warranted for continued production.

If the Design-Build Team does not operate by the limited production procedures as specified above, the 5 lots, which require corrective action, will be considered unacceptable and may be subject to removal and replacement.

The adjustment schedule for the Cumulative Straightedge Index (CSI) test results per lot is as follows:

Adjustment Schedule for Cumulative Straightedge Index (CSI) (Obtained by adding SE Index of up to 25 consecutive 100 ft. (30m) sections)		
*CSI	<u>ACCEPTANCE</u> CATEGORY	<u>CORRECTIVE</u> ACTION
0-0	Acceptable	None
1-0 or 2-0	Acceptable	None
3-0 or 4-0	Acceptable	None
1-1, 2-1, 5-0 or 6-0	Acceptable	Allowed
3-1, 4-1, 5-1 or 6-1	Acceptable	Allowed
Any other Number	Unacceptable	Required

***Either Before or After Corrective Actions**

Correct any deviation that exceeds a 0.4 inch (10 mm) blanking band such that the deviation is reduced to 0.3 inches (7.5 mm) or less.

Corrective actions shall be performed at the Design-Build Team's expense and shall be presented for evaluation and approval by the Engineer prior to proceeding. Any corrective action performed shall not reduce the integrity or durability of the pavement which is to remain in place. Corrective action for deviation repair may consist of overlaying, removing and replacing, indirect heating and rerolling. Scraping of the pavement with any blade type device will not be allowed as a corrective action. Provide overlays of the same type mix, full roadway width, and to the length and depth established by the Engineer. Tapering of the longitudinal edges of the overlay will not be allowed.

Corrective actions will not be allowed for lots having a CSI of 40 or better. Take corrective actions as specified if the CSI indicates "Required" corrective action. The CSI after corrective action should meet or exceed "Acceptable" requirements.

Where corrective action is allowed or required, the test section(s) requiring corrective action will be retested, unless the Engineer directs the retesting of the of the entire lot.

Test sections and/or lots that are initially tested by the Design-Build Team which indicate excessive deviations such that corrective action is allowed or required, may be re-rolled with asphalt rollers while the mix is still warm and in a workable condition, to possibly correct the problem. In this instance, reevaluation of the test section(s) must be completed within 24 hours of pavement placement and these test results will serve as the initial test results.

Areas excluded from testing by the N.C. Hearne Straightedge will be tested by using a non-mobile 10-foot (3m) straightedge. Assure that the variation of the surface from the testing edge of the straightedge between any two contact points with the surface is not more than 1/8

inch (3mm). Correct deviations exceeding the allowable tolerance in accordance with the corrective actions specified above, unless the Engineer permits other corrective actions.

Furnish the North Carolina Hearne Straightedge(s) necessary to perform this work. Maintain responsibility for all costs relating to the procurement, handling, and maintenance of these devices. The Department has entered into a license agreement with a manufacturer to fabricate, sell, and distribute the N.C. Hearne Straightedge. The Department's Pavement Construction Section may be contacted for the name of the current manufacturer and the approximate price of the straightedge.

DB6R45

DISPOSAL OF WASTE AND DEBRIS (2-19-02)

Revise the 2002 *Standard Specifications* as follows:

Page 8-9, Subarticle 802-2(7. Buffer Zones:)

At the end of the last sentence in this subarticle, add the words "unless superseded by an environmental permit."

DB8 R03

GUARDRAIL POSTS AND OFFSET BLOCKS (12/20/05)

Revise the 2002 *Standard Specifications* as follows:

Page 8-45, Subarticle 862-3, 4th paragraph, delete this paragraph and replace with the following:

Where rock interferes with the proper installation of the post, excavate a shaft in the rock not less than 9" wide, parallel to the roadway, by 23" long, perpendicular to the roadway, and 24" deep. Place the post against the roadside edge of the shaft and fill in behind the post with Select Material Class VI up to the top elevation of the rock. Fill the remainder of the hole with earth material. Where timber posts are to be driven in fill slopes 1 1/2:1 or steeper and the fill height is 15 feet or more, auger a 6" diameter pilot hole to the full depth of the post before driving.

Page 8-50, Subarticle 865-3, third paragraph, delete this paragraph and replace with the following:

Where rock interferes with the proper installation of the post, excavate a shaft in the rock not less than 9" wide, parallel to the roadway, by 23" long, perpendicular to the roadway, and 24" deep. Place the post against the roadside edge of the shaft and fill in behind the post with Select Material Class VI up to the top elevation of the rock. Fill the remainder of the hole with earth material. Where timber posts are to be driven in fill slopes 1 1/2:1 or steeper and the fill height is 15 feet or more, auger a 6" diameter pilot hole to the full depth of the post before driving.

Page 10-69, Subarticle 1046-3

Delete this sub-article in its entirety and replace with the following:

1046-3 POSTS AND OFFSET BLOCKS.**(A) General:**

The Design-Build Team may, at his option, furnish either of the following types of steel guardrail posts. Only one type of post will be permitted at any one continuous installation. Use structural steel posts throughout the project, unless otherwise directed or detailed in the plans.

1. Steel W6 x 8.5 or W6 x 9.0 posts.
2. Steel 4.5" x 6.0" "C" shape posts. (C150 x 12.2 kg/m)

The Design-Build Team may, at his option, furnish either of the following types of treated timber posts if specifically directed or detailed in the plans. Only one type of post will be permitted at any one continuous installation.

1. Timber 6" x 8" (152 mm x 203 mm) posts.
2. Timber 8" x 8" (203 mm x 203 mm) posts.

(B) Structural Steel Posts:

Fabricate steel posts for guardrail of the size and weight shown on the plans from structural steel complying with the requirements of Section 1072. Metal from which C shape posts are fabricated shall meet the requirements of ASTM A570 for any grade of steel, except that mechanical requirements shall meet the requirements of ASTM A36. Punch or drill the holes for connecting bolts. Burning will not be permitted. After fabrication, the posts shall be galvanized in accordance with Section 1076.

(C) Treated Timber Posts:

All timber guardrail posts shall be of treated southern pine meeting the requirements of Article 1082-2 and 1082-3.

Bore bolt holes to a driving fit for the bolts. A minus tolerance of 1 percent will be allowed in the length of the post. Perform all framing and boring before the posts receive preservative treatment.

(D) Offset Blocks:

Provide 8-inch deep recycled plastic or composite offset blocks that have been approved for use with the guardrail shown in the standard drawings and/or plans. Only one type of offset block will be permitted at any one continuous installation. Prior to beginning the installation of recycled offset block, submit the FHWA acceptance letter, for each type of block, to the Engineer for approval.

Treated timber offset blocks with steel beam guardrail will not be allowed unless required by the specifications, directed by the Engineer, or detailed on the plans. Steel offset blocks with steel beam guardrail will not be allowed.

Recycled plastic or composite offset blocks shall be made from no less than 50% recycled plastic or composite and meet the following minimum requirements:

- Specific Gravity: 0.950
- Compressive Strength in Lateral Direction: 1600 psi (11 MPa)

- Maximum Water Absorption: 10% by weight
- Maximum Termite and Ant Infestation: 10%
- Testing: Shall pass NCHRP Report 350, Test Level 3 by CRASH TESTING

Revise the *2002 Standard Roadway Drawings* as follows:

Sheet 4 of 6, Standard 862.03, delete the note and substitute the following:

Note: The midpost and offset block of the WTR section will require special bolt hole drilling in the thrie beam offset block and line post.

DB8 R57

STREET SIGNS AND MARKERS AND ROUTE MARKERS (7-1-95)

Move any existing street signs, markers, and route markers out of the construction limits of the project and install the street signs and markers and route markers so that they will be visible to the traveling public if there is sufficient right of way for these signs and markers outside of the construction limits.

Near the completion of the project and when so directed by the Engineer, move the signs and markers and install them in their proper location in regard to the finished pavement of the project.

Stockpile any signs or markers that cannot be relocated due to lack of right of way, or any signs and markers that will no longer be applicable after the construction of the project, at locations directed by the Engineer for removal by others.

The Design-Builder will be responsible to the owners for any damage to any street signs and markers or route markers during the above described operations.

DB9 R01

AGGREGATE PRODUCTION (11-20-01)

Provide aggregate from a producer who utilizes the new Aggregate Quality Control/Quality Assurance Program that is in effect at the time of shipment.

No price adjustment is allowed to Design-Build Team or producers who utilize the new program. Participation in the new program does not relieve the producer of the responsibility of complying with all requirements of the Standard Specifications. Copies of this procedure are available upon request from the Materials and Test Unit.

DB10 R05

CONCRETE BRICK AND BLOCK PRODUCTION (11-20-01)

Provide concrete brick and block from a producer who utilizes the new Solid Concrete Masonry Brick/Unit Quality Control/Quality Assurance Program that is in effect on the date that material is received on the project.

No price adjustment is allowed to Design-Build Team or producers who utilize the new program. Participation in the new program does not relieve the producer of the responsibility of complying with all requirements of the Standard Specifications. Copies of this procedure are available upon request from the Materials and Test Unit.

DB10 R10

FINE AGGREGATE (11-19-02)

Revise the 2002 Standard Specifications as follows:

Page 10-17, Table 1005-2

Make the following change to the table:

For Standard Size 2MS the following gradation change applies.

The minimum percent shown for material passing the No. 8 (2.36mm) sieve has been changed from 84 to **80**.

DB10 R15

BORROW MATERIAL (2-17-04)

Revise the 2002 *Standard Specifications* as follows:

Page 10-44

Section 1018-2 II (b) Delete the last sentence in its entirety.

DB10 R17

RETROREFLECTIVE SHEETING (6/21/05)

Revise the 2002 *Standard Specifications* as follows:

WORK ZONE SIGNS

Article 1089-1(A) General is deleted. Substitute the following:

(A) General:

Rigid sign retroreflective sheeting requirements for Types VII, VIII and IX (prismatic) fluorescent are described in Tables 1089-A, 1089-B and 1089-C. Cover the entire sign face of the sign substrate with NCDOT approved Type VII, VIII or IX (prismatic) fluorescent orange reflective sheeting. Apply the reflective sheeting in a workmanlike manner so that there are no bubbles or wrinkles in the material.

Roll-up sign retroreflective requirements are described in Table 1089-D.

1. Work Zones Signs (Stationary)

Use Type VII, VIII or IX (prismatic) fluorescent orange retroreflective sheeting that meets the following reflective requirements in Tables 1089-A, 1089-B or 1089-C respectively. Use approved composite or aluminum for sign backing. Signs and sign supports must meet or exceed NCHRP 350 requirements for Breakaway Devices.

Table 1089-A Minimum Coefficient of Retroreflection R_A for TYPE VII Fluorescent Orange Sheeting (Candelas per lux per square meter)		
	Entrance Angle	
Observation Angle	-4°	30°
0.1°	300	170
0.2°	230	130
0.5°	72	41

Table 1089-B Minimum Coefficient of Retroreflection R_A for TYPE VIII Fluorescent Orange Sheeting (Candelas per lux per square meter)		
	Entrance Angle	
Observation Angle	-4°	30°
0.1°	300	135
0.2°	210	95
0.5°	75	35

Table 1089-C Minimum Coefficient of Retroreflection R_A for TYPE IX Fluorescent Orange Sheeting (Candelas per lux per square meter)		
	Entrance Angle	
Observation Angle	-4°	30°
0.1°	200	110
0.2°	115	65
0.5°	72	41
1.0°	24	14

2. Work Zones Signs (Barricade Mounted)

Use approved composite or roll-up signs for barricade mounted sign substrates. Approved composite barricade mounted warning signs (black on orange) must be Type VII, VIII or IX sheeting which meet the retroreflective requirements of Table 1089-A, 1089-B or 1089-C. Roll-up mounted barricade warning signs (black on orange) must meet the retroreflective requirements in Table 1089-D. Sign and barricade assembly must meet or exceed the requirements of NCHRP 350 for Work Zone Category II Devices.

3. Work Zones Signs (Portable)

Use approved composite or roll-up sign substrates on portable sign stands.

Composite - Use Type VII, VIII or IX (prismatic) fluorescent orange retroreflective sheeting that meets the following reflective requirements in Tables 1089-A, 1089-B or 1089-C. Signs and sign supports must meet or exceed NCHRP 350 requirements for Breakaway Devices.

Roll-up Signs - Use fluorescent orange retroreflective roll-up signs that meet the following reflective requirements:

Table 1089-D Minimum Coefficient of Retroreflection R_A for Fluorescent Orange Roll-Up Signs (Candelas per lux per square meter)		
	Entrance Angle	
Observation Angle	-4°	30°
0.1°	300	120
0.2°	200	80
0.5°	90	34

Use roll up signs that have a minimum 3/16” x 1 1/4” horizontal rib and 38” x 1 1/4” vertical rib and has been crash test to meet NCHRP 350 requirements and Traffic Control qualified by the Work Zone Traffic Control Unit.

Add the following after 1089-1(C):

(D) Warranty

Warranty requirements for rigid sign retroreflective sheeting Types VII, VIII and IX are described in Subarticle 1093-2(F). Such sheeting shall maintain 80% (Table 1093-10) of its retroreflectivity as shown in Tables 1089 A, B, and C.

Roll-up fluorescent orange retroreflective signs shall maintain 80% of its retroreflectivity (Table 1089-D) for years 1 – 2 and 50% for year 3.

Rigid and Rollup Fluorescent orange signs shall maintain a Fluorescence Luminance Factor (Y_F)* of 13% for three (3) years.

*Fluorescence Testing Method is described in ASTM E2301 Test Methods for Fluorescent Retro reflective Sheeting.

Rigid and Roll up fluorescent orange signs shall maintain a total Luminance Factor (Y) of 25 for three (3) years and conform to the requirements of Table 1089-E when measured in accordance with ASTM D4956.

Table 1089-E								
Fluorescent Orange colorimetric requirements								
Color	1		2		3		4	
	x	y	x	y	x	y	x	Y
Fluorescent Orange	0.583	0.416	0.535	0.400	0.595	0.351	0.645	0.355

BARRICADES

Article 1089-3(A) General, delete both paragraphs and substitute the following:

Type III Barricades shall be constructed of perforated square steel tubing and/or angle iron. Provide Type III barricades that use a cross member or stabilization bar and meet the requirements of NCHRP 350 for Work Zone Category II Devices with composite and roll-up signs attached.

Use approved composite or plastic barricade rails that have a smooth face and have alternating orange and white retroreflective stripes that slope at an angle of 45 degrees.

Article 1089-3(C) Reflective Sheeting, delete the first paragraph only and substitute the following:

Use Type VII, VIII or IX (prismatic) retroreflective fluorescent orange sheeting on both sides of the barricade rails. The rail sheeting retroreflectivity values shall meet the retroreflectivity requirements in Table 1089-A, 1089-B or 1089-C and shall be listed on the Department's approved product list or accepted as traffic qualified by the Traffic Control Unit.

DB10R30

DRUMS (7-16-02)

Revise the 2002 Standard Specifications as follows:

Page 10-195, Subarticle 1089-5(C)

Delete the first (1st) sentence of the first (1st) paragraph and insert the following:

“Provide a minimum of three orange and two white alternating horizontal circumferential stripes covering the entire outside with each drum.”

DB11 R05

PORTABLE CONCRETE BARRIER (9-6-05)

Portable Concrete Barrier used on this project must meet one of the following:

- NC Approved NCHRP 350 Portable Concrete Barrier (design can be found at <http://www.ncdot.org/doh/construction/wztc/> or can be obtained by calling the Traffic Control Section at (919) 250-4159)
- Other NCHRP 350 Portable Concrete Barrier as approved by the Engineer and the Traffic Control Section
- NC Approved NCHRP 230 Portable Concrete Barrier in *Roadway Standard Drawing* 1170.01 manufactured before October 1, 2002

DB11 R10

WORK ZONE SIGNS (1/18/05)

Revise the *Standard Specifications* as follows:

DESCRIPTION

Page 11-5, **Article 1110-1 Description**

Replace the second paragraph with the following:

Furnish, install, maintain and relocate portable work zone signs and portable work zone sign stands in accordance with the plans and specifications. When portable work zone signs and portable work zone sign stands are not in use for periods longer than 30 minutes, collapse sign stand and reinstall once work begins.

Replace the last sentence in the third paragraph with the following:

Use work zone signs (portable) only with portable work zone sign stands specifically designed for one another. Work Zone Signs (portable) may be roll up or approved composite.

MATERIALS

Page 11-5, **Article 1110-2 Part (A) General:**

Add the following:

Barricade Mounted Signs.....Article 1089-3

MATERIAL QUALIFICATIONS

Page 11-5, **Article 1110-2 Part (B) Material Qualifications.**

Delete the first sentence in the first paragraph and replace with the following:

Provide portable work zone sign stands, portable signs and sign sheeting which are listed on the North Carolina Department of Transportation’s approved product list or accepted as traffic qualified by the Traffic Control Unit.

Delete “Traffic Control Section” in the second sentence of the first paragraph and insert “Traffic Control Unit”.

CONSTRUCTION METHODS

Page 11-6, Article 1110-3 CONSTRUCTION METHODS.

Replace **Article 1110-3 (B) Work Zone Signs (Barricade Mounted)** with the following:

Mount approved composite or roll-up signs to barricade rails so that the signs do not cover more than 50 percent of the top two rails or 33 percent of the total area of the three rails. Signs are to be mounted a minimum of 1’ from the ground to the bottom of the sign.

Replace **Article 1110-3 (C, 2) Work Zone Signs (Portable)** with the following:

Install portable work zone signs to carry roll-up or approved composite at a minimum height of 1’ from the bottom of the sign to the ground on two lane-two way roadways.

Install portable work zone signs to carry roll-up or approved composite at a minimum height of 5’ from the bottom of the sign to the ground on multi-lane roadways.

DB11 R15

BARRICADES (1/18/05)

Revise the 2002 *Standard Specifications* as follows:

Page 11- 12, **Article 1145-2 Materials**, delete the contents and substitute the following:

(A) General

Refer to Division 10:

Barricades..... Article 1089-3

(B) Material Qualifications

Provide Type III barricades and barricade rails that are listed on the North Carolina Department of Transportation’s approved product list or accepted as traffic qualified by the Traffic Control Unit. For more information on the Traffic Qualification process, contact the Traffic Control Unit at Century Center Building B, 1020 Birch Ridge Drive, Raleigh, NC 27610; (919) 250-4159, or see the approved product list on the NCDOT web site at: <http://www.ncdot.org/doh/construction/wztc/>

(C) Historical Performance:

Historical performance of Type III barricades and barricade rails will be used in determining future use of the material by the NCDOT, even if the Type III Barricade is traffic-qualified. Poor past or poor current performance of Type III Barricades at any site, whether or not related to a specific contract may be grounds for non-acceptance of a product on any project under contract.

DB11 R20

PAVEMENT MARKING GENERAL REQUIREMENTS (9-6-05)

Revise the 2002 *Standard Specifications* as follows:

Page 12-10, Subarticle 1205-3(J)

Delete the first (1st) sentence of the first (1st) paragraph and insert the following:

“Have at least one member of every pavement marking crew working on a project certified through the NCDOT Pavement Marking Technician Certification Process. For more information contact the Traffic Control, Marking and Delineation Section of the North Carolina Department of Transportation at 919-250-4159 or <http://www.ncdot.org/doh/construction/wztc/>”

DB12 R01

AVAILABILITY OF FUNDS - TERMINATION OF CONTRACTS

In accordance with *General Statute 143-28.1 (6), Subsection (5) of G.S. 143-28.1* is hereby incorporated verbatim in this contract. *General Statute. 143-28.1(5)* is as follows:

“(5). Amounts Obligated - Payments subject to the Availability of Funds - Termination of Contracts. Highway maintenance and construction appropriations may be obligated in the amount of allotments made to the Department of Transportation by the Office of State Budget and Management for the estimated payments for maintenance and construction contract work to be performed in the appropriation fiscal year. The allotments shall be multi-year allotments and shall be based on estimated revenues and shall be subject to the maximum contract authority contained in subdivision (2) above. Payment for highway maintenance and construction work performed pursuant to contract in any fiscal year other than the current fiscal year will be subject to appropriations by the General Assembly. Highway maintenance and construction contracts shall contain a schedule of estimated completion progress and any acceleration of this progress shall be subject to the approval of the Department of Transportation provided funds are available. The State reserves the right to terminate or suspend any highway maintenance or construction contract and any highway maintenance or construction contract shall be so terminated or suspended if funds will not be available for payment of the work to be performed during that fiscal year pursuant to the contract. In the event of termination of any contract, the Design-Builder shall be given a written notice of termination at least 60 days before completion of schedule work for which funds are available. In the event of termination, the Design-Builder shall be paid for the work already performed in accordance with the contract specifications”.

Payment will be made on any contract terminated pursuant to the special provision in accordance with Section 108-13 Item 5 of the Standard Special Provisions, Division 1 (found elsewhere in this proposal).

NCDOT GENERAL SEED SPECIFICATION FOR SEED QUALITY (1-26-05)

Seed shall be sampled and tested by the North Carolina Department of Agriculture and Consumer Services, Seed Testing Laboratory. When said samples are collected, the vendor shall supply an independent laboratory report for each lot to be tested. Results from seed so sampled shall be final. Seed not meeting the specifications shall be rejected by the Department of Transportation and shall not be delivered to North Carolina Department of Transportation warehouses. If seed has been delivered it shall be available for pickup and replacement at the supplier's expense.

Any re-labeling required by the North Carolina Department of Agriculture and Consumer Services, Seed Testing Laboratory, that would cause the label to reflect as otherwise specified herein shall be rejected by the North Carolina Department of Transportation.

Seed shall be free from seeds of the noxious weeds Johnsongrass, Balloonvine, Jimsonweed, Witchweed, Itchgrass, Serrated Tussock, Showy Crotalaria, Smooth Crotalaria, Sicklepod, Sandbur, Wild Onion, and Wild Garlic. Seed shall not be labeled with the above weed species on the seed analysis label. Tolerances as applied by the Association of Official Seed Analysts will NOT be allowed for the above noxious weeds except for Wild Onion and Wild Garlic.

Tolerances established by the Association of Official Seed Analysts will generally be recognized. However, for the purpose of figuring pure live seed, the found pure seed and found germination percentages as reported by the North Carolina Department of Agriculture and Consumer Services, Seed Testing Laboratory will be used. Allowances, as established by the NCDOT, will be recognized for minimum pure live seed as listed on the following pages.

The specifications for restricted noxious weed seed refers to the number per pound as follows:

<u>Restricted Noxious Weed</u>	<u>Limitations per Lb. Of Seed</u>	<u>Restricted Noxious Weed</u>	<u>Limitations per Lb. of Seed</u>
Blessed Thistle	4 seeds	Bermudagrass	27 seeds
Cocklebur	4 seeds	Cornflower (Ragged Robin)	27 seeds
Spurred Anoda	4 seeds	Texas Panicum	27 seeds
Velvetleaf	4 seeds	Bracted Plantain	54 seeds
Morning-glory	8 seeds	Buckhorn Plantain	54 seeds
Corn Cockle	10 seeds	Broadleaf Dock	54 seeds
Wild Radish	12 seeds	Curly Dock	54 seeds
Purple Nutsedge	27 seeds	Dodder	54 seeds
Yellow Nutsedge	27 seeds	Giant Foxtail	54 seeds
Canada Thistle	27 seeds	Horsenettle	54 seeds
Field Bindweed	27 seeds	Quackgrass	54 seeds
Hedge Bindweed	27 seeds	Wild Mustard	54 seeds

Seed of Pensacola Bahiagrass shall not contain more than 7% inert matter, Kentucky Bluegrass and Fine or Hard Fescue shall not contain more than 5% inert matter whereas a maximum of 2% inert matter will be allowed on all other kinds of seed. In addition, all seed shall not contain

more than 2% other crop seed nor more than 1% total weed seed. The germination rate as tested by the North Carolina Department of Agriculture shall not fall below 70%, which includes both dormant and hard seed. Seed shall be labeled with not more than 7%, 5% or 2% inert matter (according to above specifications), 2% other crop seed and 1% total weed seed.

Exceptions may be made for minimum pure live seed allowances when cases of seed variety shortages are verified. Pure live seed percentages will be applied in a verified shortage situation. Those purchase orders of deficient seed lots will be credited with the percentage that the seed is deficient.

FURTHER SPECIFICATIONS FOR EACH SEED GROUP ARE GIVE BELOW:

Minimum 85% pure live seed; maximum 1% total weed seed; maximum 2% total other crop seed; maximum 144 restricted noxious weed seed per pound. Seed less than 83% pure live seed will not be approved.

Sericea Lespedeza
Oats (seeds)

Minimum 80% pure live seed; maximum 1% total weed seed; maximum 2% total other crop; maximum 144 restricted noxious weed seed per pound. Seed less than 78% pure live seed will not be approved.

Tall Fescue (all approved varieties)	Bermudagrass
Kobe Lespedeza	Browntop Millet
Korean Lespedeza	German Millet - Strain R
Weeping Lovegrass	Centipedegrass
Carpetgrass	Clover - Red/White/Crimson

Minimum 78% pure live seed; maximum 1% total weed seed; maximum 2% total other crop seed; maximum 144 restricted noxious weed seed per pound. Seed less than 76% pure live seed will not be approved.

Common or Sweet Sundangrass

Minimum 76% pure live seed; maximum 1% total weed seed; maximum 2% total other crop seed; maximum 144 restricted noxious weed seed per pound. Seed less than 74% pure live seed will not be approved.

Rye (grain; all varieties)
Kentucky Bluegrass (all approved varieties)
Hard Fescue (all approved varieties)
Shrub (bicolor) Lespedeza

Minimum 70% pure live seed; maximum 1% total weed seed; maximum 2% total other crop seed; maximum 144 restricted noxious weed seed per pound. Seed less than 70% pure live seed will not be approved.

Crownvetch
Japanese Millet
Reed Canary Grass

Pensacola Bahiagrass
Switchgrass

Minimum 65% pure live seed; maximum 1% total weed seed; maximum 2% total other crop seed; maximum 144 restricted noxious weed seed per pound. Seed less than 60% pure live seed will not be approved.

Little Bluestem
Switchgrass

Minimum 75% pure live seed; maximum 1% total weed seed; maximum 2% total other crop seed; maximum 144 restricted noxious weed seed per pound. Seed less than 70% pure live seed will not be approved.

Big Bluestem

Minimum 78% pure live seed; maximum 1% total weed seed; maximum 2% total other crop seed; maximum 144 restricted noxious weed seed per pound. Seed less than 73% pure live seed will not be approved.

Indiangrass

STANDARD SPECIAL PROVISIONS**ERRATA** (4-19-05)

Correct the *2002 Standard Specifications* as follows:

Page 1-61, Subarticle 108-10(A)

In the first paragraph, first sentence, change the Article reference from 101-24 to 101-25. In the second paragraph, first sentence, add Article reference 101-46 and 101-49.

Page 1-62, Subarticle 108-10(B) 3.

In the third paragraph, first sentence, change the Article reference from 101-24 to 101-25; change Article reference 101-47 to 101-48; and change Article reference 101 - 48 to Article 101-49.

Page 2-21, Subarticle 235-4(B)

In the third sub-bullet under the eighth bullet in this subarticle, delete the word "subgrade" and insert the words "finished grade".

Page 3-4, Article 300-10

Change all references to 300-8 to 300-9.

Page 5-9, Subarticle 520-3(A)

Delete the words "at your option".

Page 5-10, Subarticle 520-6(A)

In the first sentence, add a period after "(B)" and delete the words "and (C)."

Delete the last sentence of the subarticle.

Page 8-47, Subarticle 862-6

Change the subarticle number from 862-6 to 862-7.

Change references in section from 862-5 to 862-6

Page 8-49, Subarticle 864-4

In the first paragraph, change the Article reference from 862-3 to **864-3**.

Page 8-55, Subarticle 866-5(G)

In the third pay item, insert the words "with Posts" after the word "Fence".

Page 10-1, Subarticle 1000-3(A)

In the second paragraph, change 550 psi to 600 psi (4.1 MPa).

Page 10-2, Subarticle 1000-3(A)

In the last sentence of the second paragraph on this page, change 550 psi to 600 psi (4.1 MPa).

Page 10-5, Table 1000-1

Under the column "Consistency Max. Slump" change the sub-heading 'Non-Vibrated' to 'Vibrated' and change the sub-heading 'Vibrated' to 'Non-Vibrated'. Under the column "Min. Cement Content" change the sub-heading 'Non-Vibrated' to 'Vibrated' and change the sub-heading 'Vibrated' to 'Non-Vibrated'.

Page 10-17, Table 1005-2

For Std. Size # 2S make the following changes:

- #50 (0.300) Sieve change the limits from 8 - 30 to **5 - 30**.
- #100 (0.150) Sieve change the limits from 0.5 - 10 to **0 - 10**.

For Std. Size # 2MS make the following changes:

- #50 (0.300) Sieve change the limits from 8 - 35 to **5 - 35**.
- #100 (0.150) Sieve change the limits from 0.5 - 20 to **0 - 20**.

Page 15-3, Article 1505-3

In the last paragraph of this article, change Article 300-6 to Article 300-7.

Page 15-10, Article 1510-5

In the fourth paragraph, insert a comma after the word "water".

Page 15-18, Article 1530-2

In the third paragraph on the page, change "Section 812" to "Section 340".

Page 16-15, Article 1635-3(A)

Substitute the second paragraph with the following:

Construct the rock pipe inlet sediment trap type-A with a minimum height of 18 inches (457.2 mm) and a minimum of 12 inches (304.8 mm) below the roadway shoulder or diversion point.

AWARD OF CONTRACT

“The North Carolina Department of Transportation, in accordance with the provisions of Title VI of the *Civil Rights Act of 1964* (78 Stat. 252) and the Regulations of the Department of Transportation (49 C.F.R., Part 21), issued pursuant to such act, hereby notifies all bidders that it will affirmatively insure that the contract entered into pursuant to this advertisement will be awarded to the lowest responsible bidder without discrimination on the ground of race, color, or national origin”.

MINORITY AND FEMALE EMPLOYMENT REQUIREMENTS**NOTICE OF REQUIREMENTS FOR AFFIRMATIVE ACTION TO ENSURE EQUAL EMPLOYMENT OPPORTUNITY (*EXECUTIVE NUMBER 11246*)**

1. The goals and timetables for minority and female participation, expressed in percentage terms for the Design Build Team's aggregate workforce in each trade on all construction work in the covered area, see as shown on the attached sheet entitled "Employment Goals for Minority and Female participation".

These goals are applicable to all the Design Build Team's construction work (whether or not it is Federal or federally assisted) performed in the covered area. If the Design Build Team performs construction work in a geographical area located outside of the covered area, it shall apply the goals established for such geographical area where the work is actually performed. With regard to this second area, the Design Build Team also is subject to the goals for both its federally involved and nonfederally involved construction.

The Design Build Team's compliance with the Executive Order and the regulations in *41 CFR Part 60-4* shall be based on its implementation of the Equal Opportunity Clause, specific affirmative action obligations required by the specifications set forth in *41 CFR 60-4.3(a)*, and its effort to meet the goals. The hours of minority and female employment and training must be substantially uniform throughout the length of the contract, and in each trade and the Design Build Team shall make a good faith effort to employ minorities and women evenly on each of its projects. The transfer of minority or female employees or trainees from Design Build Team to Design Build Team or from project to project or the sole purpose of meeting the Design Build Team's goals shall be a violation of the contract, the executive Order and the regulations in *41 CFR Part 60-4*. Compliance with the goals will be measured against the total work hours performed.

2. As used in this Notice and in the contract resulting from this solicitation, the "covered area" is the county or counties shown on the cover sheet of the proposal form and contract.

EMPLOYMENT GOALS FOR MINORITY
AND FEMALE PARTICIPATION

Economic Areas

Area 023 29.7%

Bertie County
Camden County
Chowan County
Gates County
Hertford County
Pasquotank County
Perquimans County

Area 024 31.7%

Beaufort County
Carteret County
Craven County
Dare County
Edgecombe County
Green County
Halifax County
Hyde County
Jones County
Lenoir County
Martin County
Nash County
Northampton County
Pamlico County
Pitt County
Tyrrell County
Washington County
Wayne County
Wilson County

Area 025 23.5%

Columbus County
Duplin County
Onslow County
Pender County

Area 026 33.5%

Bladen County
Hoke County
Richmond County
Robeson County
Sampson County
Scotland County

Area 027 24.7%

Chatham County
Franklin County
Granville County
Harnett County
Johnston County
Lee County
Person County
Vance County
Warren County

Area 028 15.5%

Alleghany County
Ashe County
Caswell County
Davie County
Montgomery County
Moore County
Rockingham County
Surry County
Watauga County
Wilkes County

Area 029 15.7%

Alexander County
Anson County
Burke County
Cabarrus County
Caldwell County
Catawba County
Cleveland County
Iredell County
Lincoln County
Polk County
Rowan County
Rutherford County
Stanly County

Area 0480 8.5%

Buncombe County
Madison County

Area 030 6.3%

Avery County
Cherokee County
Clay County
Graham County
Haywood County
Henderson County
Jackson County
McDowell County
Macon County
Mitchell County
Swain County
Transylvania County
Yancey County

SMSA Areas

Area 5720 26.6%

Currituck County

Area 9200 20.7%

Brunswick County
New Hanover County

Area 2560 24.2%

Cumberland County

Area 6640 22.8%

Durham County
Orange County
Wake County

Area 1300 16.2%

Alamance County

Area 3120 16.4%

Davidson County
Forsyth County
Guiford County
Randolph County
Stokes County
Yadkin County

Area 1520 18.3%

Gaston County
Mecklenburg County
Union County

Goals for Female

Participation in Each Trade

(Statewide) 6.9%

REQUIRED CONTRACT PROVISIONS FEDERAL-AID CONSTRUCTION CONTRACTS FHWA-1273

- I. General
- II. Nondiscrimination
- III. Nonsegregated Facilities
- IV. Payment of Predetermined Minimum Wage
- V. Statements and Payrolls
- VI. Record of Materials, Supplies, and Labor
- VII. Subletting or Assigning the Contract
- VIII. Safety: Accident Prevention
- IX. False Statements Concerning Highway Projects
- X. Implementation of Clean Air Act and Federal Water Pollution Control Act
- XI. Certification Regarding Debarment, Suspension Ineligibility, and Voluntary Exclusion
- XII. Certification Regarding Use of Contract Funds for Lobbying

Attachments

- A. Employment Preference for Appalachian Contracts (included in Appalachian contracts only)

I. GENERAL

1. These contract provisions shall apply to all work performed on the contract by the contractor's own organization and with the assistance of workers under the contractor's immediate superintendence and to all work performed on the contract by piecework, station work, or by subcontract.
2. Except as otherwise provided for in each section, the contractor shall insert in each subcontract all of the stipulations contained in these Required Contract Provisions, and further require their inclusion in any lower tier subcontract or purchase order that may in turn be made. The Required Contract Provisions shall not be incorporated by reference in any case. The prime contractor shall be responsible for compliance by any subcontractor or lower tier subcontractor with these Required Contract Provisions.
3. A breach of any of the stipulations contained in these Required Contract Provisions shall be sufficient grounds for termination of the contract.
4. A breach of the following clauses of the Required Contract Provisions may also be grounds for debarment as provided in 29 CFR 5.12:
 - Section I, paragraph 2;
 - Section IV, paragraphs 1, 2, 3, 4, and 7;
 - Section V, paragraphs 1 and 2a through 2g.
5. Disputes arising out of the labor standards provisions of Section IV (except paragraph 5) and Section V of these Required Contract Provisions shall not be subject to the general disputes clause of this contract. Such disputes shall be resolved in accordance with the procedures of the U.S. Department of Labor (DOL) as set forth in 29 CFR 5, 6, and 7. Disputes within the meaning of this clause include disputes between the contractor (or any of its subcontractors) and the contracting agency, the DOL, or the contractor's employees or their representatives.
6. **Selection of Labor:** During the performance of this contract, the contractor shall not:
 - a. discriminate against labor from any other State, possession, or territory of the United States (except for employment preference for Appalachian contracts, when applicable, as specified in Attachment A), or
 - b. employ convict labor for any purpose within the limits of the project unless it is labor performed by convicts who are on parole, supervised release, or probation.

II. NONDISCRIMINATION

(Applicable to all Federal-aid construction contracts and to all related subcontracts of \$10,000 or more.)

1. **Equal Employment Opportunity:** Equal employment opportunity (EEO) requirements not to discriminate and to take affirmative action to assure equal opportunity as set forth under laws, executive orders, rules, regulations (28 CFR 35, 29 CFR 1630 and 41 CFR 60) and orders of the Secretary of Labor as modified by the provisions prescribed herein, and imposed pursuant to 23 U.S.C. 140 shall constitute the EEO and specific affirmative action standards for the contractor's project activities under this contract. The Equal Opportunity Construction Contract Specifications set forth under 41 CFR 60-4.3 and the provisions of the American Disabilities Act of 1990 (42 U.S.C. 12101 *et seq.*) set forth under 28 CFR 35 and 29 CFR 1630 are incorporated by reference in this contract. In the execution of this contract, the contractor agrees to comply with the following minimum specific requirement activities of EEO:
 - a. The contractor will work with the State highway agency (SHA) and the Federal Government in carrying out EEO obligations and in their review of his/her activities under the contract.
 - b. The contractor will accept as his operating policy the following statement:

"It is the policy of this Company to assure that applicants are employed, and that employees are treated during employment, without regard to their race, religion, sex, color, national origin, age or disability. Such action shall include: employment, upgrading, demotion, or transfer; recruitment or recruitment advertising; layoff or termination; rates of pay or other forms of compensation; and selection for training, including apprenticeship, preapprenticeship, and/or on-the-job training."
2. **EEO Officer:** The contractor will designate and make known to the SHA contracting officers an EEO Officer who will have the responsibility for and must be capable of effectively administering and promoting an active contractor program of EEO and who must be assigned adequate authority and responsibility to do so.

3. **Dissemination of Policy:** All members of the contractor's staff who are authorized to hire, supervise, promote, and discharge employees, or who recommend such action, or who are substantially involved in such action, will be made fully cognizant of, and will implement, the contractor's EEO policy and contractual responsibilities to provide EEO in each grade and classification of employment. To ensure that the above agreement will be met, the following actions will be taken as a minimum:
 - a. Periodic meetings of supervisory and personnel office employees will be conducted before the start of work and then not less often than once every six months, at which time the contractor's EEO policy and its implementation will be reviewed and explained. The meetings will be conducted by the EEO Officer.
 - b. All new supervisory or personnel office employees will be given a thorough indoctrination by the EEO Officer, covering all major aspects of the contractor's EEO obligations within thirty days following their reporting for duty with the contractor.
 - c. All personnel who are engaged in direct recruitment for the project will be instructed by the EEO Officer in the contractor's procedures for locating and hiring minority group employees.
 - d. Notices and posters setting forth the contractor's EEO policy will be placed in areas readily accessible to employees, applicants for employment and potential employees.
 - e. The contractor's EEO policy and the procedures to implement such policy will be brought to the attention of employees by means of meetings, employee handbooks, or other appropriate means.
4. **Recruitment:** When advertising for employees, the contractor will include in all advertisements for employees the notation: "An Equal Opportunity Employer." All such advertisements will be placed in publications having a large circulation among minority groups in the area from which the project work force would normally be derived.
 - a. The contractor will, unless precluded by a valid bargaining agreement, conduct systematic and direct recruitment through public and private employee referral sources likely to yield qualified minority group applicants. To meet this requirement, the contractor will identify sources of potential minority group employees, and establish with such identified sources procedures whereby minority group applicants may be referred to the contractor for employment consideration.
 - b. In the event the contractor has a valid bargaining agreement providing for exclusive hiring hall referrals, he is expected to observe the provisions of that agreement to the extent that the system permits the contractor's compliance with EEO contract provisions. (The DOL has held that where implementation of such agreements have the effect of discriminating against minorities or women, or obligates the contractor to do the same, such implementation violates Executive Order 11246, as amended.)
 - c. The contractor will encourage his present employees to refer minority group applicants for employment. Information and procedures with regard to referring minority group applicants will be discussed with employees.
5. **Personnel Actions:** Wages, working conditions, and employee benefits shall be established and administered, and personnel actions of every type, including hiring, upgrading, promotion, transfer, demotion, layoff, and termination, shall be taken without regard to race, color, religion, sex, national origin, age or disability. The following procedures shall be followed:
 - a. The contractor will conduct periodic inspections of project sites to insure that working conditions and employee facilities do not indicate discriminatory treatment of project site personnel.
 - b. The contractor will periodically evaluate the spread of wages paid within each classification to determine any evidence of discriminatory wage practices.
 - c. The contractor will periodically review selected personnel actions in depth to determine whether there is evidence of discrimination. Where evidence is found, the contractor will promptly take corrective action. If the review indicates that the discrimination may extend beyond the actions reviewed, such corrective action shall include all affected persons.
 - d. The contractor will promptly investigate all complaints of alleged discrimination made to the contractor in connection with his obligations under this contract, will attempt to resolve such complaints, and will take appropriate corrective action within a reasonable time. If the investigation indicates that the discrimination may affect persons other than the complainant, such corrective action shall include such other persons. Upon completion of each investigation, the contractor will inform every complainant of all of his avenues of appeal.
6. **Training and Promotion:**
 - a. The contractor will assist in locating, qualifying, and increasing the skills of minority group and women employees, and applicants for employment.
 - b. Consistent with the contractor's work force requirements and as permissible under Federal and State regulations, the contractor shall make full use of training programs, i.e., apprenticeship, and on-the-job training programs for the geographical area of contract performance. Where feasible, 25 percent of apprentices or trainees in each occupation shall be in their first year of apprenticeship or training. In the event a special provision for training is provided under this contract, this subparagraph will be superseded as indicated in the special provision.
 - c. The contractor will advise employees and applicants for employment of available training programs and entrance requirements for each.
 - d. The contractor will periodically review the training and promotion potential of minority group and women employees and will encourage eligible employees to apply for such training and promotion.
7. **Unions:** If the contractor relies in whole or in part upon unions as a source of employees, the contractor will use his/her best efforts to obtain the cooperation of such unions to increase opportunities for minority groups and women within the unions, and to effect referrals by such unions of minority and female employees. Actions by the contractor either directly or through a contractor's association acting as agent will include the procedures set forth below:
 - a. The contractor will use best efforts to develop, in cooperation with the unions, joint training programs aimed toward qualifying more minority group members and women for membership in the unions and increasing the skills of minority group employees and women so that they may qualify for higher paying employment.
 - b. The contractor will use best efforts to incorporate an EEO clause into each union agreement to the end that such union will be contractually bound to refer applicants without regard to their race, color, religion, sex, national origin, age or disability.
 - c. The contractor is to obtain information as to the referral practices and policies of the labor union except that to the extent such information is within the exclusive possession of the labor union and such labor union refuses to furnish such

information to the contractor, the contractor shall so certify to the SHA and shall set forth what efforts have been made to obtain such information.

- d. In the event the union is unable to provide the contractor with a reasonable flow of minority and women referrals within the time limit set forth in the collective bargaining agreement, the contractor will, through independent recruitment efforts, fill the employment vacancies without regard to race, color, religion, sex, national origin, age or disability; making full efforts to obtain qualified and/or qualifiable minority group persons and women. (The DOL has held that it shall be no excuse that the union with which the contractor has a collective bargaining agreement providing for exclusive referral failed to refer minority employees.) In the event the union referral practice prevents the contractor from meeting the obligations pursuant to Executive Order 11246, as amended, and these special provisions, such contractor shall immediately notify the SHA.
8. **Selection of Subcontractors, Procurement of Materials and Leasing of Equipment:** The contractor shall not discriminate on the grounds of race, color, religion, sex, national origin, age or disability in the selection and retention of subcontractors, including procurement of materials and leases of equipment.
 - a. The contractor shall notify all potential subcontractors and suppliers of his/her EEO obligations under this contract.
 - b. Disadvantaged business enterprises (DBE), as defined in 49 CFR 23, shall have equal opportunity to compete for and perform subcontracts which the contractor enters into pursuant to this contract. The contractor will use his best efforts to solicit bids from and to utilize DBE subcontractors or subcontractors with meaningful minority group and female representation among their employees. Contractors shall obtain lists of DBE construction firms from SHA personnel.
 - c. The contractor will use his best efforts to ensure subcontractor compliance with their EEO obligations.
9. **Records and Reports:** The contractor shall keep such records as necessary to document compliance with the EEO requirements. Such records shall be retained for a period of three years following completion of the contract work and shall be available at reasonable times and places for inspection by authorized representatives of the SHA and the FHWA.
 - a. The records kept by the contractor shall document the following:
 1. The number of minority and non-minority group members and women employed in each work classification on the project;
 2. The progress and efforts being made in cooperation with unions, when applicable, to increase employment opportunities for minorities and women;
 3. The progress and efforts being made in locating, hiring, training, qualifying, and upgrading minority and female employees; and
 4. The progress and efforts being made in securing the services of DBE subcontractors or subcontractors with meaningful minority and female representation among their employees.
 - b. The contractors will submit an annual report to the SHA each July for the duration of the project, indicating the number of minority, women, and non-minority group employees currently engaged in each work classification required by the contract work. This information is to be reported on Form FHWA-1391. If on-the-job training is being required by special provision, the contractor will be required to collect and report training data.

III. NONSEGREGATED FACILITIES

(Applicable to all Federal-aid construction contracts and to all related subcontracts of \$10,000 or more.)

- a. By submission of this bid, the execution of this contract or subcontract, or the consummation of this material supply agreement or purchase order, as appropriate, the bidder, Federal-aid construction contractor, subcontractor, material supplier, or vendor, as appropriate, certifies that the firm does not maintain or provide for its employees any segregated facilities at any of its establishments, and that the firm does not permit its employees to perform their services at any location, under its control, where segregated facilities are maintained. The firm agrees that a breach of this certification is a violation of the EEO provisions of this contract. The firm further certifies that no employee will be denied access to adequate facilities on the basis of sex or disability.
- b. As used in this certification, the term "segregated facilities" means any waiting rooms, work areas, restrooms and washrooms, restaurants and other eating areas, timeclocks, locker rooms, and other storage or dressing areas, parking lots, drinking fountains, recreation or entertainment areas, transportation, and housing facilities provided for employees which are segregated by explicit directive, or are, in fact, segregated on the basis of race, color, religion, national origin, age or disability, because of habit, local custom, or otherwise. The only exception will be for the disabled when the demands for accessibility override (e.g. disabled parking).
- c. The contractor agrees that it has obtained or will obtain identical certification from proposed subcontractors or material suppliers prior to award of subcontracts or consummation of material supply agreements of \$10,000 or more and that it will retain such certifications in its files.

IV. PAYMENT OF PREDETERMINED MINIMUM WAGE

(Applicable to all Federal-aid construction contracts exceeding \$2,000 and to all related subcontracts, except for projects located on roadways classified as local roads or rural minor collectors, which are exempt.)

1. **General:**
 - a. All mechanics and laborers employed or working upon the site of the work will be paid unconditionally and not less often than once a week and without subsequent deduction or rebate on any account [except such payroll deductions as are permitted by regulations (29 CFR 3) issued by the Secretary of Labor under the Copeland Act (40 U.S.C. 276c)] the full amounts of wages and bona fide fringe benefits (or cash equivalents thereof) due at time of payment. The payment shall be computed at wage rates not less than those contained in the wage determination of the Secretary of Labor (hereinafter "the wage determination") which is attached hereto and made a part hereof, regardless of any contractual relationship which may be alleged to exist between the contractor or its subcontractors and such laborers and mechanics. The wage determination (including any additional classifications and wage rates conformed under paragraph 2 of this Section IV and the DOL poster (WH-1321) or Form FHWA-1495) shall be posted at all times by the contractor and its subcontractors at the site of the work in a prominent and accessible place where it can be easily seen by the workers. For the purpose of this Section, contributions made or costs reasonably anticipated for bona fide fringe benefits under Section 1(b)(2) of the Davis-Bacon Act (40 U.S.C. 276a) on behalf of laborers or mechanics are considered wages paid to such laborers or mechanics, subject to the provisions of Section IV, paragraph 3b, hereof. Also, for the purpose of this Section, regular contributions made or costs incurred for more than a weekly period (but not less often than quarterly)

under plans, funds, or programs, which cover the particular weekly period, are deemed to be constructively made or incurred during such weekly period. Such laborers and mechanics shall be paid the appropriate wage rate and fringe benefits on the wage determination for the classification of work actually performed, without regard to skill, except as provided in paragraphs 4 and 5 of this Section IV.

- b. Laborers or mechanics performing work in more than one classification may be compensated at the rate specified for each classification for the time actually worked therein, provided, that the employer's payroll records accurately set forth the time spent in each classification in which work is performed.
- c. All rulings and interpretations of the Davis-Bacon Act and related acts contained in 29 CFR 1, 3, and 5 are herein incorporated by reference in this contract.

2. Classification:

- a. The SHA contracting officer shall require that any class of laborers or mechanics employed under the contract, which is not listed in the wage determination, shall be classified in conformance with the wage determination.
- b. The contracting officer shall approve an additional classification, wage rate and fringe benefits only when the following criteria have been met:
 - 1. the work to be performed by the additional classification requested is not performed by a classification in the wage determination;
 - 2. the additional classification is utilized in the area by the construction industry;
 - 3. the proposed wage rate, including any bona fide fringe benefits, bears a reasonable relationship to the wage rates contained in the wage determination; and
 - 4. with respect to helpers, when such a classification prevails in the area in which the work is performed.
- c. If the contractor or subcontractors, as appropriate, the laborers and mechanics (if known) to be employed in the additional classification or their representatives, and the contracting officer agree on the classification and wage rate (including the amount designated for fringe benefits where appropriate), a report of the action taken shall be sent by the contracting officer to the DOL, Administrator of the Wage and Hour Division, Employment Standards Administration, Washington, D.C. 20210. The Wage and Hour Administrator, or an authorized representative, will approve, modify, or disapprove every additional classification action within 30 days of receipt and so advise the contracting officer or will notify the contracting officer within the 30-day period that additional time is necessary.
- d. In the event the contractor or subcontractors, as appropriate, the laborers or mechanics to be employed in the additional classification or their representatives, and the contracting officer do not agree on the proposed classification and wage rate (including the amount designated for fringe benefits, where appropriate), the contracting officer shall refer the questions, including the views of all interested parties and the recommendation of the contracting officer, to the Wage and Hour Administrator for determination. Said Administrator, or an authorized representative, will issue a determination within 30 days of receipt and so advise the contracting officer or will notify the contracting officer within the 30-day period that additional time is necessary.
- e. The wage rate (including fringe benefits where appropriate) determined pursuant to paragraph 2c or 2d of this Section IV shall be paid to all workers performing work in the additional classification from the first day on which work is performed in the classification.

3. Payment of Fringe Benefits:

- a. Whenever the minimum wage rate prescribed in the contract for a class of laborers or mechanics includes a fringe benefit which is not expressed as an hourly rate, the contractor or subcontractors, as appropriate, shall either pay the benefit as stated in the wage determination or shall pay another bona fide fringe benefit or an hourly case equivalent thereof.
- b. If the contractor or subcontractor, as appropriate, does not make payments to a trustee or other third person, he/she may consider as a part of the wages of any laborer or mechanic the amount of any costs reasonably anticipated in providing bona fide fringe benefits under a plan or program, provided, that the Secretary of Labor has found, upon the written request of the contractor, that the applicable standards of the Davis-Bacon Act have been met. The Secretary of Labor may require the contractor to set aside in a separate account assets for the meeting of obligations under the plan or program.

4. Apprentices and Trainees (Programs of the U.S. DOL) and Helpers:

- a. Apprentices:
 - 1. Apprentices will be permitted to work at less than the predetermined rate for the work they performed when they are employed pursuant to and individually registered in a bona fide apprenticeship program registered with the DOL, Employment and Training Administration, Bureau of Apprenticeship and Training, or with a State apprenticeship agency recognized by the Bureau, or if a person is employed in his/her first 90 days of probationary employment as an apprentice in such an apprenticeship program, who is not individually registered in the program, but who has been certified by the Bureau of Apprenticeship and Training or a State apprenticeship agency (where appropriate) to be eligible for probationary employment as an apprentice.
 - 2. The allowable ratio of apprentices to journeyman-level employees on the job site in any craft classification shall not be greater than the ratio permitted to the contractor as to the entire work force under the registered program. Any employee listed on a payroll at an apprentice wage rate, who is not registered or otherwise employed as stated above, shall be paid not less than the applicable wage rate listed in the wage determination for the classification of work actually performed. In addition, any apprentice performing work on the job site in excess of the ratio permitted under the registered program shall be paid not less than the applicable wage rate on the wage determination for the work actually performed. Where a contractor or subcontractor is performing construction on a project in a locality other than that in which its program is registered, the ratios and wage rates (expressed in percentages of the journeyman-level hourly rate) specified in the contractor's or subcontractor's registered program shall be observed.
 - 3. Every apprentice must be paid at not less than the rate specified in the registered program for the apprentice's level of progress, expressed as a percentage of the journeyman-level hourly rate specified in the applicable

wage determination. Apprentices shall be paid fringe benefits in accordance with the provisions of the apprenticeship program. If the apprenticeship program does not specify fringe benefits, apprentices must be paid the full amount of fringe benefits listed on the wage determination for the applicable classification. If the Administrator for the Wage and Hour Division determines that a different practice prevails for the applicable apprentice classification, fringes shall be paid in accordance with that determination.

4. In the event the Bureau of Apprenticeship and Training, or a State apprenticeship agency recognized by the Bureau, withdraws approval of an apprenticeship program, the contractor or subcontractor will no longer be permitted to utilize apprentices at less than the applicable predetermined rate for the comparable work performed by regular employees until an acceptable program is approved.
- b. Trainees:
1. Except as provided in 29 CFR 5.16, trainees will not be permitted to work at less than the predetermined rate for the work performed unless they are employed pursuant to and individually registered in a program which has received prior approval, evidenced by formal certification by the DOL, Employment and Training Administration.
 2. The ratio of trainees to journeyman-level employees on the job site shall not be greater than permitted under the plan approved by the Employment and Training Administration. Any employee listed on the payroll at a trainee rate who is not registered and participating in a training plan approved by the Employment and Training Administration shall be paid not less than the applicable wage rate on the wage determination for the classification of work actually performed. In addition, any trainee performing work on the job site in excess of the ratio permitted under the registered program shall be paid not less than the applicable wage rate on the wage determination for the work actually performed.
 3. Every trainee must be paid at not less than the rate specified in the approved program for his/her level of progress, expressed as a percentage of the journeyman-level hourly rate specified in the applicable wage determination. Trainees shall be paid fringe benefits in accordance with the provisions of the trainee program. If the trainee program does not mention fringe benefits, trainees shall be paid the full amount of fringe benefits listed on the wage determination unless the Administrator of the Wage and Hour Division determines that there is an apprenticeship program associated with the corresponding journeyman-level wage rate on the wage determination which provides for less than full fringe benefits for apprentices, in which case such trainees shall receive the same fringe benefits as apprentices.
 4. In the event the Employment and Training Administration withdraws approval of a training program, the contractor or subcontractor will no longer be permitted to utilize trainees at less than the applicable predetermined rate for the work performed until an acceptable program is approved.
- c. Helpers:

Helpers will be permitted to work on a project if the helper classification is specified and defined on the applicable wage determination or is approved pursuant to the conformance procedure set forth in Section IV.2. Any worker listed on a payroll at a helper wage rate, who is not a helper under a approved definition, shall be paid not less than the applicable wage rate on the wage determination for the classification of work actually performed.

5. **Apprentices and Trainees (Programs of the U.S. DOT):** Apprentices and trainees working under apprenticeship and skill training programs which have been certified by the Secretary of Transportation as promoting EEO in connection with Federal-aid highway construction programs are not subject to the requirements of paragraph 4 of this Section IV. The straight time hourly wage rates for apprentices and trainees under such programs will be established by the particular programs. The ratio of apprentices and trainees to journeymen shall not be greater than permitted by the terms of the particular program.
6. **Withholding:** The SHA shall upon its own action or upon written request of an authorized representative of the DOL withhold, or cause to be withheld, from the contractor or subcontractor under this contract or any other Federal contract with the same prime contractor, or any other Federally-assisted contract subject to Davis-Bacon prevailing wage requirements which is held by the same prime contractor, as much of the accrued payments or advances as may be considered necessary to pay laborers and mechanics, including apprentices, trainees, and helpers, employed by the contractor or any subcontractor the full amount of wages required by the contract. In the event of failure to pay any laborer or mechanic, including any apprentice, trainee, or helper, employed or working on the site of the work, all or part of the wages required by the contract, the SHA contracting officer may, after written notice to the contractor, take such action as may be necessary to cause the suspension of any further payment, advance, or guarantee of funds until such violations have ceased.
7. **Overtime Requirements:** No contractor or subcontractor contracting for any part of the contract work which may require or involve the employment of laborers, mechanics, watchmen, or guards (including apprentices, trainees, and helpers described in paragraphs 4 and 5 above) shall require or permit any laborer, mechanic, watchman, or guard in any workweek in which he/she is employed on such work, to work in excess of 40 hours in such workweek unless such laborer, mechanic, watchman, or guard receives compensation at a rate not less than one-and-one-half times his/her basic rate of pay for all hours worked in excess of 40 hours in such workweek.
8. **Violation:** Liability for Unpaid Wages; Liquidated Damages: In the event of any violation of the clause set forth in paragraph 7 above, the contractor and any subcontractor responsible thereof shall be liable to the affected employee for his/her unpaid wages. In addition, such contractor and subcontractor shall be liable to the United States (in the case of work done under contract for the District of Columbia or a territory, to such District or to such territory) for liquidated damages. Such liquidated damages shall be computed with respect to each individual laborer, mechanic, watchman, or guard employed in violation of the clause set forth in paragraph 7, in the sum of \$10 for each calendar day on which such employee was required or permitted to work in excess of the standard work week of 40 hours without payment of the overtime wages required by the clause set forth in paragraph 7.

9. **Withholding for Unpaid Wages and Liquidated Damages:**

The SHA shall upon its own action or upon written request of any authorized representative of the DOL withhold, or cause to be withheld, from any monies payable on account of work performed by the contractor or subcontractor under any such contract or any other Federal contract with the same prime contractor, or any other Federally-assisted contract subject to the Contract Work Hours and Safety Standards Act, which is held by the same prime contractor, such sums as may be determined to be necessary to satisfy any liabilities of such contractor or subcontractor for unpaid wages and liquidated damages as provided in the clause set forth in paragraph 8 above.

V. **STATEMENTS AND PAYROLLS**

(Applicable to all Federal-aid construction contracts exceeding \$2,000 and to all related subcontracts, except for projects located on roadways classified as local roads or rural collectors, which are exempt.)

1. **Compliance with Copeland Regulations (29 CFR 3):**

The contractor shall comply with the Copeland Regulations of the Secretary of Labor which are herein incorporated by reference.

2. **Payrolls and Payroll Records:**

- a. Payrolls and basic records relating thereto shall be maintained by the contractor and each subcontractor during the course of the work and preserved for a period of 3 years from the date of completion of the contract for all laborers, mechanics, apprentices, trainees, watchmen, helpers, and guards working at the site of the work.
- b. The payroll records shall contain the name, social security number, and address of each such employee; his or her correct classification; hourly rates of wages paid (including rates of contributions or costs anticipated for bona fide fringe benefits or cash equivalent thereof of the types described in Section 1(b)(2)(B) of the Davis Bacon Act); daily and weekly number of hours worked; deductions made; and actual wages paid. In addition, for Appalachian contracts, the payroll records shall contain a notation indicating whether the employee does, or does not, normally reside in the labor area as defined in Attachment A, paragraph 1. Whenever the Secretary of Labor, pursuant to Section IV, paragraph 3b, has found that the wages of any laborer or mechanic include the amount of any costs reasonably anticipated in providing benefits under a plan or program described in Section 1(b)(2)(B) of the Davis Bacon Act, the contractor and each subcontractor shall maintain records which show that the commitment to provide such benefits is enforceable, that the plan or program is financially responsible, that the plan or program has been communicated in writing to the laborers or mechanics affected, and show the cost anticipated or the actual cost incurred in providing benefits. Contractors or subcontractors employing apprentices or trainees under approved programs shall maintain written evidence of the registration of apprentices and trainees, and ratios and wage rates prescribed in the applicable programs.
- c. Each contractor and subcontractor shall furnish, each week in which any contract work is performed, to the SHA resident engineer a payroll of wages paid each of its employees (including apprentices, trainees, and helpers, described in Section IV, paragraphs 4 and 5, and watchmen and guards engaged on work during the preceding weekly payroll period). The payroll submitted shall set out accurately and completely all of the information required to be maintained under paragraph 2b of this Section V. This information may be submitted in any form desired. Optional Form WH-347 is available for this purpose and may be purchased from the Superintendent of Documents (Federal stock number 029-005-0014-1), U.S. Government Printing Office, Washington, D.C. 20402. The prime contractor is responsible for the submission of copies of payrolls by all subcontractors.
- d. Each payroll submitted shall be accompanied by a "Statement of Compliance," signed by the contractor or subcontractor or his/her agent who pays or supervises the payment of the persons employed under the contract and shall certify the following:
 1. that the payroll for the payroll period contains the information required to be maintained under paragraph 2b of this Section V and that such information is correct and complete;
 2. that such laborer or mechanic (including each helper, apprentice, and trainee) employed on the contract during the payroll period has been paid the full weekly wages earned, without rebate, either directly or indirectly, and that no deductions have been made either directly or indirectly from the full wages earned, other than permissible deductions as set forth in the Regulations, 29 CFR 3;
 3. that each laborer or mechanic has been paid not less than the applicable wage rate and fringe benefits or cash equivalent for the classification of work performed, as specified in the applicable wage determination incorporated into the contract.
- e. The weekly submission of a properly executed certification set forth on the reverse side of Optional Form WH-347 shall satisfy the requirement for submission of the "Statement of Compliance" required by paragraph 2d of this Section V.
- f. The falsification of any of the above certifications may subject the contractor to civil or criminal prosecution under 18 U.S.C. 1001 and 31 U.S.C. 231.
- g. The contractor or subcontractor shall make the records required under paragraph 2b of this Section V available for inspection, copying, or transcription by authorized representatives of the SHA, the FHWA, or the DOL, and shall permit such representatives to interview employees during working hours on the job. If the contractor or subcontractor fails to submit the required records or to make them available, the SHA, the FHWA, the DOL, or all may, after written notice to the contractor, sponsor, applicant, or owner, take such actions as may be necessary to cause the suspension of any further payment, advance, or guarantee of funds. Furthermore, failure to submit the required records upon request or to make such records available may be grounds for debarment action pursuant to 29 CFR 5.12.

VI. **RECORD OF MATERIALS, SUPPLIES, AND LABOR**

1. On all Federal-aid contracts on the National Highway System, except those which provide solely for the installation of protective devices at railroad grade crossings, those which are constructed on a force account or direct labor basis, highway beautification contracts, and contracts for which the total final construction cost for roadway and bridge is less than \$1,000,000 (23 CFR 635) the contractor shall:
 - a. Become familiar with the list of specific materials and supplies contained in Form FHWA-47, "Statement of Materials and Labor Used by Contractor of Highway Construction Involving Federal Funds," prior to the commencement of work under this contract.

- b. Maintain a record of the total cost of all materials and supplies purchased for and incorporated in the work, and also of the quantities of those specific materials and supplies listed on Form FHWA-47, and in the units shown on Form FHWA-47.
 - c. Furnish, upon the completion of the contract, to the SHA resident engineer on Form FHWA-47 together with the data required in paragraph 1b, relative to materials and supplies, a final labor summary of all contract work indicating the total hours worked and the total amount earned.
2. At the prime contractor's option, either a single report covering all contract work or separate reports for the contractor and for each subcontract shall be submitted.

VII. SUBLETTING OR ASSIGNING THE CONTRACT

1. The contractor shall perform with its own organization contract work amounting to not less than 30 percent (or a greater percentage if specified elsewhere in the contract) of the total original contract price, excluding any specialty items designated by the State. Specialty items may be performed by subcontract and the amount of any such specialty items performed may be deducted from the total original contract price before computing the amount of work required to be performed by the contractor's own organization (23 CFR 635).
 - a. "Its own organization" shall be construed to include only workers employed and paid directly by the prime contractor and equipment owned or rented by the prime contractor, with or without operators. Such term does not include employees or equipment of a subcontractor, assignee, or agent of the prime contractor.
 - b. "Specialty Items" shall be construed to be limited to work that requires highly specialized knowledge, abilities, or equipment not ordinarily available in the type of contracting organizations qualified and expected to bid on the contract as a whole and in general are to be limited to minor components of the overall contract.
2. The contract amount upon which the requirements set forth in paragraph 1 of Section VII is computed includes the cost of material and manufactured products which are to be purchased or produced by the contractor under the contract provisions.
3. The contractor shall furnish (a) a competent superintendent or supervisor who is employed by the firm, has full authority to direct performance of the work in accordance with the contract requirements, and is in charge of all construction operations (regardless of who performs the work) and (b) such other of its own organizational resources (supervision, management, and engineering services) as the SHA contracting officer determines is necessary to assure the performance of the contract.
4. No portion of the contract shall be sublet, assigned or otherwise disposed of except with the written consent of the SHA contracting officer, or authorized representative, and such consent when given shall not be construed to relieve the contractor of any responsibility for the fulfillment of the contract. Written consent will be given only after the SHA has assured that each subcontract is evidenced in writing and that it contains all pertinent provisions and requirements of the prime contract.

VIII. SAFETY: ACCIDENT PREVENTION

1. In the performance of this contract the contractor shall comply with all applicable Federal, State, and local laws governing safety, health, and sanitation (23 CFR 635). The contractor shall provide all safeguards, safety devices and protective equipment and take any other needed actions as it determines, or as the SHA contracting officer may determine, to be reasonably necessary to protect the life and health of employees on the job and the safety of the public and to protect property in connection with the performance of the work covered by the contract.
2. It is a condition of this contract, and shall be made a condition of each subcontract, which the contractor enters into pursuant to this contract, that the contractor and any subcontractor shall not permit any employee, in performance of the contract, to work in surroundings or under conditions which are unsanitary, hazardous or dangerous to his/her health or safety, as determined under construction safety and health standards (29 CFR 1926) promulgated by the Secretary of Labor, in accordance with Section 107 of the Contract Work Hours and Safety Standards Act (40 U.S.C. 333).
3. Pursuant to 29 CFR 1926.3, it is a condition of this contract that the Secretary of Labor or authorized representative thereof, shall have right of entry to any site of contract performance to inspect or investigate the matter of compliance with the construction safety and health standards and to carry out the duties of the Secretary under Section 107 of the Contract Work Hours and Safety Standards Act (40 U.S.C. 333).

IX. FALSE STATEMENTS CONCERNING HIGHWAY PROJECTS

In order to assure high quality and durable construction in conformity with approved plans and specifications and a high degree of reliability on statements and representations made by engineers, contractors, suppliers, and workers on Federal-aid highway projects, it is essential that all persons concerned with the project perform their functions as carefully, thoroughly, and honestly as possible. Willful falsification, distortion, or misrepresentation with respect to any facts related to the project is a violation of Federal law. To prevent any misunderstanding regarding the seriousness of these and similar acts, the following notice shall be posted on each Federal-aid highway project (23 CFR 635) in one or more places where it is readily available to all persons concerned with the project:

NOTICE TO ALL PERSONNEL ENGAGED ON FEDERAL-AID HIGHWAY PROJECTS

18 U.S.C. 1020 reads as follows:

"Whoever, being an officer, agent, or employee of the United States, or of any State or Territory, or whoever, whether a person, association, firm, or corporation, knowingly makes any false statement, false representation, or false report as to the character, quality, quantity, or cost of the material used or to be used, or the quantity or quality of the work performed or to be performed, or the cost thereof in connection with the submission of plans, maps, specifications, contracts, or costs of construction on any highway or related project submitted for approval to the Secretary of Transportation; or

Whoever knowingly makes any false statement, false representation, false report or false claim with respect to the character, quality, quantity, or cost of any work performed or to be performed, or materials furnished or to be furnished, in connection with the construction of any highway or related project approved by the Secretary of Transportation; or

Whoever knowingly makes any false statement or false representation as to material fact in any statement, certificate, or report submitted pursuant to provisions of the Federal-aid Roads Act approved July 1, 1916, (39 Stat. 355), as amended and supplemented;

Shall be fined not more than \$10,000 or imprisoned not more than 5 years or both."

X. IMPLEMENTATION OF CLEAN AIR ACT AND FEDERAL WATER POLLUTION CONTROL ACT

(Applicable to all Federal-aid construction contracts and to all related subcontracts of \$100,000 or more.)

By submission of this bid or the execution of this contract, or subcontract, as appropriate, the bidder, Federal-aid construction contractor, or subcontractor, as appropriate, will be deemed to have stipulated as follows:

1. That any facility that is or will be utilized in the performance of this contract, unless such contract is exempt under the Clean Air Act, as amended (42 U.S.C. 1857 *et seq.*, as amended by Pub.L. 91-604), and under the Federal Water Pollution Control Act, as amended (33 U.S.C. 1251 *et seq.*, as amended by Pub.L. 92-500), Executive Order 11738, and regulations in implementation thereof (40 CFR 15) is not listed, on the date of contract award, on the U.S. Environmental Protection Agency (EPA) List of Violating Facilities pursuant to 40 CFR 15.20.
2. That the firm agrees to comply and remain in compliance with all the requirements of Section 114 of the Clean Air Act and Section 308 of the Federal Water Pollution Control Act and all regulations and guidelines listed thereunder.
3. That the firm shall promptly notify the SHA of the receipt of any communication from the Director, Office of Federal Activities, EPA, indicating that a facility that is or will be utilized for the contract is under consideration to be listed on the EPA List of Violating Facilities.
4. That the firm agrees to include or cause to be included the requirements of paragraph 1 through 4 of this Section X in every nonexempt subcontract, and further agrees to take such action as the government may direct as a means of enforcing such requirements.

XI. CERTIFICATION REGARDING DEBARMENT, SUSPENSION, INELIGIBILITY AND VOLUNTARY EXCLUSION

1. Instructions for Certification - Primary Covered Transactions:

(Applicable to all Federal-aid contracts - 49 CFR 29)

- a. By signing and submitting this proposal, the prospective primary participant is providing the certification set out below.
- b. The inability of a person to provide the certification set out below will not necessarily result in denial of participation in this covered transaction. The prospective participant shall submit an explanation of why it cannot provide the certification set out below. The certification or explanation will be considered in connection with the department or agency's determination whether to enter into this transaction. However, failure of the prospective primary participant to furnish a certification or an explanation shall disqualify such a person from participation in this transaction.
- c. The certification in this clause is a material representation of fact upon which reliance was placed when the department or agency determined to enter into this transaction. If it is later determined that the prospective primary participant knowingly rendered an erroneous certification, in addition to other remedies available to the Federal Government, the department or agency may terminate this transaction for cause of default.
- d. The prospective primary participant shall provide immediate written notice to the department or agency to whom this proposal is submitted if any time the prospective primary participant learns that its certification was erroneous when submitted or has become erroneous by reason of changed circumstances.
- e. The terms "covered transaction," "debarred," "suspended," "ineligible," "lower tier covered transaction," "participant," "person," "primary covered transaction," "principal," "proposal," and "voluntarily excluded," as used in this clause, have the meanings set out in the Definitions and Coverage sections of rules implementing Executive Order 12549. You may contact the department or agency to which this proposal is submitted for assistance in obtaining a copy of those regulations.
- f. The prospective primary participant agrees by submitting this proposal that, should the proposed covered transaction be entered into, it shall not knowingly enter into any lower tier covered transaction with a person who is debarred, suspended, declared ineligible, or voluntarily excluded from participation in this covered transaction, unless authorized by the department or agency entering into this transaction.
- g. The prospective primary participant further agrees by submitting this proposal that it will include the clause titled "Certification Regarding Debarment, Suspension, Ineligibility and Voluntary Exclusion-Lower Tier Covered Transaction," provided by the department or agency entering into this covered transaction, without modification, in all lower tier covered transactions and in all solicitations for lower tier covered transactions.
- h. A participant in a covered transaction may rely upon a certification of a prospective participant in a lower tier covered transaction that is not debarred, suspended, ineligible, or voluntarily excluded from the covered transaction, unless it knows that the certification is erroneous. A participant may decide the method and frequency by which it determines the eligibility of its principals. Each participant may, but is not required to, check the nonprocurement portion of the "Lists of Parties Excluded From Federal Procurement or Nonprocurement Programs" (Nonprocurement List) which is compiled by the General Services Administration.
- i. Nothing contained in the foregoing shall be construed to require establishment of a system of records in order to render in good faith the certification required by this clause. The knowledge and information of participant is not required to exceed that which is normally possessed by a prudent person in the ordinary course of business dealings.
- j. Except for transactions authorized under paragraph f of these instructions, if a participant in a covered transaction knowingly enters into a lower tier covered transaction with a person who is suspended, debarred, ineligible, or voluntarily excluded from participation in this transaction, in addition to other remedies available to the Federal Government, the department or agency may terminate this transaction for cause or default.

Certification Regarding Debarment, Suspension, Ineligibility and Voluntary Exclusion--Primary Covered Transactions

11. The prospective primary participant certifies to the best of its knowledge and belief, that it and its principals:
 - a. Are not presently debarred, suspended, proposed for debarment, declared ineligible, or voluntarily excluded from covered transactions by any Federal department or agency;
 - b. Have not within a 3-year period preceding this proposal been convicted of or had a civil judgement rendered against them for commission of fraud or a criminal offense in connection with obtaining, attempting to obtain, or performing a public (Federal, State or local) transaction or contract under a public transaction; violation of Federal or State antitrust statutes or commission of embezzlement, theft, forgery, bribery, falsification or destruction of records, making false statements, or receiving stolen property;
 - c. Are not presently indicted for or otherwise criminally or civilly charged by a governmental entity (Federal, State or local) with commission of any of the offenses enumerated in paragraph 1b of this certification; and
 - d. Have not within a 3-year period preceding this application/proposal had one or more public transactions (Federal, State or local) terminated for cause or default.

12. Where the prospective primary participant is unable to certify to any of the statements in this certification, such prospective participant shall attach an explanation to this proposal.

• * * * *

2. **Instructions for Certification - Lower Tier Covered Transactions:**

(Applicable to all subcontracts, purchase orders and other lower tier transactions of \$25,000 or more - 49 CFR 29)

- a. By signing and submitting this proposal, the prospective lower tier is providing the certification set out below.
- b. The certification in this clause is a material representation of fact upon which reliance was placed when this transaction was entered into. If it is later determined that the prospective lower tier participant knowingly rendered an erroneous certification, in addition to other remedies available to the Federal Government, the department, or agency with which this transaction originated may pursue available remedies, including suspension and/or debarment.
- c. The prospective lower tier participant shall provide immediate written notice to the person to which this proposal is submitted if at any time the prospective lower tier participant learns that its certification was erroneous by reason of changed circumstances.
- d. The terms "covered transaction," "debarred," "suspended," "ineligible," "primary covered transaction," "participant," "person," "principal," "proposal," and "voluntarily excluded," as used in this clause, have the meanings set out in the Definitions and Coverage sections of rules implementing Executive Order 12549. You may contact the person to which this proposal is submitted for assistance in obtaining a copy of those regulations.
- e. The prospective lower tier participant agrees by submitting this proposal that, should the proposed covered transaction be entered into, it shall not knowingly enter into any lower tier covered transaction with a person who is debarred, suspended, declared ineligible, or voluntarily excluded from participation in this covered transaction, unless authorized by the department or agency with which this transaction originated.
- f. The prospective lower tier participant further agrees by submitting this proposal that it will include this clause titled "Certification Regarding Debarment, Suspension, Ineligibility and Voluntary Exclusion-Lower Tier Covered Transaction," without modification, in all lower tier covered transactions and in all solicitations for lower tier covered transactions.
- g. A participant in a covered transaction may rely upon a certification of a prospective participant in a lower tier covered transaction that is not debarred, suspended, ineligible, or voluntarily excluded from the covered transaction, unless it knows that the certification is erroneous. A participant may decide the method and frequency by which it determines the eligibility of its principals. Each participant may, but is not required to, check the Nonprocurement List.
- h. Nothing contained in the foregoing shall be construed to require establishment of a system of records in order to render in good faith the certification required by this clause. The knowledge and information of participant is not required to exceed that which is normally possessed by a prudent person in the ordinary course of business dealings.
- i. Except for transactions authorized under paragraph e of these instructions, if a participant in a covered transaction knowingly enters into a lower tier covered transaction with a person who is suspended, debarred, ineligible, or voluntarily excluded from participation in this transaction, in addition to other remedies available to the Federal Government, the department or agency with which this transaction originated may pursue available remedies, including suspension and/or debarment.

* * * * *

Certification Regarding Debarment, Suspension, Ineligibility and Voluntary Exclusion--Lower Tier Covered Transactions:

10. The prospective lower tier participant certifies, by submission of this proposal, that neither it nor its principals is presently debarred, suspended, proposed for debarment, declared ineligible, or voluntarily excluded from participation in this transaction by any Federal department or agency.
11. Where the prospective lower tier participant is unable to certify to any of the statements in this certification, such prospective participant shall attach an explanation to this proposal.

* * * * *

XII. CERTIFICATION REGARDING USE OF CONTRACT FUNDS FOR LOBBYING

(Applicable to all Federal-aid construction contracts and to all related subcontracts which exceed \$100,000 - 49 CFR 20)

1. The prospective participant certifies, by signing and submitting this bid or proposal, to the best of his or her knowledge and belief, that:
 - a. No Federal appropriated funds have been paid or will be paid, by or on behalf of the undersigned, to any person for influencing or attempting to influence an officer or employee of any Federal agency, a Member of Congress, an officer or employee of Congress, or an employee of a Member of Congress in connection with the awarding of any Federal contract, the making of any Federal grant, the making of any Federal loan, the entering into of any cooperative agreement, and the extension, continuation, renewal, amendment, or modification of any Federal contract, grant, loan, or cooperative agreement.
 - b. If any funds other than Federal appropriated funds have been paid or will be paid to any person for influencing or attempting to influence an officer or employee of any Federal agency, a Member of Congress, an officer or employee of Congress, or an employee of a Member of Congress in connection with this Federal contract, grant, loan, or cooperative agreement, the undersigned shall complete and submit Standard Form-LLL, "Disclosure Form to Report Lobbying," in accordance with its instructions.
2. This certification is a material representation of fact upon which reliance was placed when this transaction was made or entered into. Submission of this certification is a prerequisite for making or entering into this transaction imposed by 31 U.S.C. 1352. Any person who fails to file the required certification shall be subject to a civil penalty of not less than \$10,000 and not more than \$100,000 for each such failure.
3. The prospective participant also agrees by submitting his or her bid or proposal that he or she shall require that the language of this certification be included in all lower tier subcontracts, which exceed \$100,000 and that all such recipients shall certify and disclose accordingly.

TRAINING SPECIAL PROVISIONS

This project special provision will not be applicable to those Design-Build Teams who have elected to participate in the Department's *Alternative On-The-Job Training Program*. In the event the Design-Build Team is participating in the Department's *Alternative On-The-Job Training Program*, the Civil Rights and Business Development Section of the Contractual Services Unit will certify that participation to the appropriate Highway Division and Resident Engineers.

This Training Special Provision supersedes subparagraph 7b of the Special Provision entitled "*Specific Equal Employment Opportunity Responsibilities*," (Attachment 1), and is in implementation of 23 USC 140(a). As a part of the Design Build Team's equal opportunity affirmative action program, training shall be provided as follows:

The Design Build Team shall provide on-the-job training aimed at developing full journey workers in the type of trade or classification involved. Preference shall be given to providing training in the following skilled work classifications:

Equipment Operators	Office Engineers
Truck Drivers	Estimators
Carpenters	Iron / Reinforcing Steel Workers
Concrete Finishers	Mechanics
Pipe Layers	Welders

The number of trainees to be trained under this contract will be as specified in the Project Special Provisions included else where in the proposal form.

In the event that a Design Build Team subcontracts a portion of the contract work, he shall determine how many, if any, of the trainees are to be trained by the subDesign Build Team, provided, however, the Design Build Team shall maintain the primary responsibility for meeting the training requirements imposed by this special provision and the subDesign Build Team has an approved on-the-job training program. The Design Build Team shall also insure that this training special provision is made applicable to such subcontract. Where feasible, 25 percent of apprentices or trainees in each occupation shall be in their first year of apprenticeship or training.

The number of trainees shall be distributed among the skilled work classifications on the basis of the Design Build Team's needs and the availability of journey workers in the various classifications within a reasonable area of recruitment. Prior to commencing construction, the Design Build Team shall submit to the Department for approval the number of trainees to be trained in each selected classification and the training program to be used. Furthermore, the Design Build Team shall specify the starting time for training in each of the classifications on the form provided by the Department. That form shall be submitted by the Design Build Team to the Department on or before the date of the pre-construction conference. The Design Build Team will be credited for each trainee employed by him on the contract work who is currently enrolled or becomes enrolled in an approved program and who receives training for at least 10 percent of the specific program requirement.

Training and upgrading of minorities and women toward journey worker_status is a primary objective of this Training Special Provision. Accordingly, the Design Build Team shall make every effort to enroll minority trainees and women (e.g., by conducting systematic and direct recruitment through public and private resources likely to yield minority and women trainees) to the extent that such persons are available within a reasonable area of recruitment. The Design Build Team will be responsible for demonstrating the steps he has taken in the pursuance thereof, prior to a determination as to whether the Design Build Team is in compliance with this Training Special Provision. This training commitment is not intended, and shall not be used, to discriminate against any applicant for training, whether a member of a minority group or not.

No employee shall be employed as a trainee in any classification in which he has successfully completed a training course leading to journey worker_status or in which he has been employed as a journey worker. The Design Build Team should satisfy this requirement by including appropriate questions in the employee application or by other suitable means. Regardless of the method used, the Design Build Team's records should document the finding in each case.

The minimum length and type of training for each classification will be as established in the training program selected by the Design Build Team and approved by the Department. The Department shall approve a program if it is reasonably calculated to meet the equal employment opportunity obligations of the Design Build Team and to qualify the average trainee for journey worker status in the classification concerned by the end of the training period. Furthermore, apprenticeship programs registered with the US Department of Labor, Bureau of Apprenticeship and Training, or with a State apprenticeship agency recognized by the US Department of Labor, Manpower Administration, Bureau of Apprenticeship and Training, shall also be considered acceptable provided it is being administered in a manner consistent with the equal employment obligations of Federal-Aid highway construction contracts. Approval or acceptance of a training program shall be obtained from the Department prior to commencing work on the classification covered by the program. It is the intention of these provisions that training be provided in the construction crafts rather than clerk-typist or secretarial-type positions. Training is permissible in lower level management positions such as office engineers, estimators, timekeepers, etc., where the training is provided and approved by the Department and the Federal Highway Administration. Some offsite training is permissible as long as the training is an integral part of an approved training program and does not comprise a significant part of the overall training.

It is normally expected that a trainee will begin his training on the project as soon as feasible after the start of work utilizing the skill involved and remain on the project as long as training opportunities exist in the work classification or until he has completed his training program. It is not required that all trainees be on board for the entire length of the contract. A Design Build Team will have fulfilled his responsibilities under this training special provision if he has provided acceptable training to the number of trainees specified. The number trained shall be determined on the basis of the total number enrolled on the Design Build Team for a significant period.

Trainees will be paid at least 60 percent of the appropriate minimum journey worker's rate specified in the contract for the first half of the training period, 75 percent for the third quarter of the training period, and 90 percent for the last quarter of the training period, unless apprentices or trainees in an approved existing program are enrolled as trainees on this project. In that case, the appropriate rates approved by the Departments of Labor or Transportation in connection with the existing program shall apply to all trainees being trained for the same classification who are covered by this Training Special Provision.

The Design Build Team, providing the training, shall furnish the trainee a copy of the program he will be following. The Design Build Team shall provide each trainee with a certificate showing the type and length of training satisfactorily completed.

The Design Build Team will provide for maintenance of records and furnish periodic reports documenting his performance under this Training Special Provision.

GENERAL DECISION NC030011 NC11

Date: June 13, 2004

General Decision Number NC030011

Superseded General Decision No. NC020011

State: North Carolina

Construction Type: **HIGHWAY****Counties**

Alamance	Durham	Orange
Alexander	Forsyth	Randolph
Buncombe	Franklin	Rowan
Burke	Gaston	Stokes
Cabarrus	Guilford	Union
Catawba	Lincoln	Wake
Cumberland	Mecklenburg	Yadkin
Davidson	New Hanover	
Davie	Onslow	

HIGHWAY CONSTRUCTION PROJECTS (does not include tunnels, building structures in rest area projects, railroad construction, and, bascule, suspension and spandrel arch bridges, bridges designed for commercial navigation, and bridges involving marine construction, and other major bridges).

Modification Number
0

Publication Date
06/13/2003

Counties

Alamance	Durham	Orange
Alexander	Forsyth	Randolph
Buncombe	Franklin	Rowan
Burke	Gaston	Stokes
Cabarrus	Guilford	Union
Catawba	Lincoln	Wake
Cumberland	Mecklenburg	Yadkin
Davidson	New Hanover	
Davie	Onslow	

SUNC3002A 02/12/1990

	Rates	Fringes
Carpenter	7.63	
Concrete Finisher	7.52	
Electrician	10.26	
Ironworkers (reinforcing)	9.76	
Laborer		
Common	5.33	
Asphalt Lay Down Man	5.60	
Asphalt Raker	6.14	
Form Setter (road)	8.57	
Mason (brick, block, stone)	7.44	
Pipe Layer	6.23	
Power Tool Operator	8.28	
Power Equipment Operators		
Asphalt Distributor	6.78	
Asphalt Paver	7.47	
Bulldozer	7.33	
Bulldozer (utility)	6.72	
Concrete Curb Machine	7.09	
Concrete Finishing Machine	7.85	
Concrete Paver	6.90	
Crane, Backhoe, Shovel & Dragline (over 1 yd)	8.16	
Crane, Backhoe, Shovel & Dragline (1 yd and over)	6.95	
Drill Operator	7.34	
Grade Checker	5.45	
Gradeall	8.38	
Greaseman	6.49	
Loader	7.09	
Mechanic	8.47	
Motor Grader (Fine Grade)	8.04	
Motor Grader(Rough Grade)	7.68	
Oiler	5.88	
Roller (Finisher)	6.70	
Roller (Rough)	5.65	
Scraper	6.63	
Screed Asphalt	7.09	
Stone Spreader	6.02	
Stripping Machine Operator	6.00	
Subgrade Machine	7.13	
Sweeper	5.80	
Tractor (Utility)	5.47	

TRUCK DRIVERS

Trucks – Single Rear Axle	5.42
Trucks – Multi Rear Axle	6.08
Trucks – Heavy Duty	9.47

WELDERS – Receive rate prescribed for craft performing operation to which welding is incidental.

Unlisted classifications needed for work not included within the scope of the classifications listed may be added after award only as provided in the labor standards contract clauses (29 CFR 5.5(a)(1)(ii)).

In the listing above, the "SU" designation means that rates listed under that identifier do not reflect collectively bargained wage and fringe benefit rates. Other designations indicate unions whose rates have been determined to be prevailing.

WAGE DETERMINATION APPEALS PROCESS

1.) Has there been an initial decision in the matter? This can be:

- * an existing published wage determination
- * a survey underlying a wage determination
- * a Wage and Hour Division letter setting forth a position on a wage determination matter
- * a conformance (additional classification and rate) ruling

On survey related matters, initial contact, including requests for summaries of surveys, should be with the Wage and Hour Regional Office for the area in which the survey was conducted because those Regional Offices have responsibility for the Davis-Bacon survey program. If the response from this initial contact is not satisfactory, then the process described in 2.) and 3.) should be followed.

With regard to any other matter not yet ripe for the formal process described here, initial contact should be with the Branch of Construction Wage Determinations. Write to:

Branch of Construction Wage Determinations
Wage and Hour Division
U. S. Department of Labor
200 Constitution Avenue, N. W.
Washington, D. C. 20210

2.) If the answer to the question in 1.) is yes, then an interested party (those affected by the action) can request review and reconsideration from the Wage and Hour Administrator (See 29 CFR Part 1.8 and 29 CFR Part 7). Write to:

Wage and Hour Administrator
U.S. Department of Labor
200 Constitution Avenue, N. W.
Washington, D. C. 20210

The request should be accompanied by a full statement of the interested party's position and by any information (wage payment data, project description, area practice material, etc.) that the requestor considers relevant to the issue.

3.) If the decision of the Administrator is not favorable, an interested party may appeal directly to the Administrative Review Board (formerly the Wage Appeals Board). Write to:

Administrative Review Board
U. S. Department of Labor
200 Constitution Avenue, N. W.
Washington, D. C. 20210

4.) All decisions by the Administrative Review Board are final.

END OF GENERAL DECISION

STANDARD SPECIAL PROVISIONS**DIVISION 1****GENERAL REQUIREMENTS****SECTION 101****DEFINITIONS OF TERMS****101-1 GENERAL**

Whenever the terms defined in this section are used in those specifications, in any of the contract documents, or on the plans, the intended meaning of such terms shall be as defined in this section.

101-2 ABBREVIATIONS

AAN	_____	American Association of Nurserymen
AAR	_____	Association of American Railroads
AASHTO	_____	American Association of State Highway and Transportation Officials
ACI	_____	American Concrete Institute
ADT	_____	Annual Average Daily Traffic
AED	_____	Associated Equipment Distributors
AGC	_____	Associated General Contractors of America
AIA	_____	American Institute of Architects
AISC	_____	American Institute of Steel Construction
AISI	_____	American Iron and Steel Institute
ANSI	_____	American National Standards Institute, Inc.
ARA	_____	American Railway Association
AREA	_____	American Railway Engineering Association
ASLA	_____	American Society of Landscape Architects
ASTM	_____	American Society for Testing and Materials
AWWA	_____	American Water Works Association
AWS	_____	American Welding Society
AWPA	_____	American Wood Preserver's Association
CRSI	_____	Concrete Reinforcing Steel Institute
DHV	_____	Design Hourly Volume
EI	_____	Edison Electric Institute
FHWA	_____	Federal Highway Administration, U.S. Department of Transportation
FSS	_____	Federal Specifications and Standards, General Services Administration
GS	_____	General Statutes of North Carolina
IES	_____	Illuminating Engineering Society
NEC	_____	National Electrical Code
NEMA	_____	National Electrical Manufacturers Association
NESC	_____	National Electrical Safety Code
SPIB	_____	Southern Pine Inspection Bureau
SSPC	_____	Steel Structures Painting Council
UL	_____	Underwriters' Laboratories, Inc.
AMRL	_____	AASHTO Materials Reference Laboratory
CCRL	_____	Cement and Concrete Reference Laboratory

101-3 ACT OF GOD.

Events in nature so extraordinary that the history of climate variations and other conditions in the particular locality affords no reasonable warning of them.

101-4 ADDITIONAL WORK.

Additional work is that which results from a change or alteration in the contract and for which there are existing contract unit prices, provided in the original contract or an executed supplemental agreement.

101-5 ADMINISTRATOR.

The State Highway Administrator.

101-6 ADVERTISEMENT.

The public advertisement inviting Request for Qualifications for the design and construction of specific projects.

101-7 ARTICLE.

A primary numbered subdivision of a section of the standard specifications.

101-8 AWARD.

The decision of the Board of Transportation to accept the proposal of the selected Design-Builder for work which is subject to the furnishing of payment and performance bonds, and such other conditions as may be otherwise provided by law, the Request for Proposals, and the Standard specifications.

101-9 BASE COURSE.

That portion of the pavement structure of planned thickness placed immediately below the pavement or surface course.

101-10 BID (OR PROPOSAL).

The offer of a Design-Builder in the form of a Design-Build price proposal and a Design-Build technical proposal to perform the work and to furnish the labor and materials at the prices quoted.

101-11 BID BOND OR BID DEPOSIT.

The security furnished by the Proposer with his proposal as guaranty that he will furnish the required bonds and execute such documents as may be required if his proposal is accepted.

101-12 BIDDER.

An individual, partnership, firm, corporation, or joint venture formally submitting a proposal for the work contemplated. On Design-Build projects the word refers to respondents to the Design-Build Proposal invitation.

101-13 BOARD OR BOARD OF TRANSPORTATION.

The Board created by the provisions of G.S. 143B-350 for the purpose of formulating policies and priorities for the Department of Transportation, and awarding all state highway construction contracts.

101-14 BRIDGE.

A structure including supports, erected over a depression or an obstruction such as water, highway, or railway, and having a track or passage way for carrying traffic or other moving loads and having a length measured along the center of the roadway of more than 20 feet between undercopings of end supports, spring lines of arches, or between extreme ends of openings for multiple reinforced concrete box structures.

Bridge Length. The length of a bridge structure is the overall length measured along the line of survey stationing back to back of backwalls of abutments, if present, otherwise end to end of the bridge floor.

Bridge Width. The clear width measured at right angles to the longitudinal centerline of the bridge between the bottom of curbs, guard timbers or face of parapets, or in the case of multiple height of curbs, between the bottoms of the lower risers.

101-15 CALENDAR DAY.

A day shown on the calendar beginning and ending at midnight.

101-16 CHIEF ENGINEER.

The Chief Engineer, Operations, Division of Highways, North Carolina Department of Transportation.

101-17 COMPLETION DATE.

That date set forth in the special provisions or as revised by authorized extensions, by which date it is required that the work set forth in the contract be satisfactorily completed.

101-18 CONSTRUCTION EASEMENT.

A right owned by the Department of Transportation in a parcel of land owned by a third party outside the highway right of way for the purpose of containing construction which exceeds the right of way.

101-19 CONTRACT.

The executed agreement between the Department of Transportation and the successful Proposer, covering the performance of the work and the compensation therefor.

The term contract is all inclusive with reference to all written agreements affecting a contractual relationship and all documents referred to therein. The contract shall specifically include, but not be limited to, the Design-Build Package, the Design-Build Technical Proposal, the Design-Build Price Proposal, the printed contract form and all attachments thereto, the contract bonds, the plans, the standard specifications and all supplemental specifications thereto, the standard special provisions and the project special provisions contained in the Design-Build Package, and all executed supplemental agreements, all of which shall constitute one instrument.

101-20 CONTRACT ITEM.

A specifically described unit of work for which a unit or lump sum price is provided in the original contract or an executed supplemental agreement. Synonymous with "Pay Item".

101-21 CONTRACT LUMP SUM PRICE.

The amount proposed for a lump sum item that has been submitted by the Design-Builder in his price proposal.

101-22 CONTRACT PAYMENT BOND.

A bond furnished by the Design-Builder and his corporate surety securing the payment of those furnishing labor, materials, and supplies for the design and construction of the project.

101-23 CONTACT PERFORMANCE BOND.

A bond furnished by the Design-Builder and his corporate surety guaranteeing the performance of the contract.

101-24 CONTRACT TIME.

The number of calendar days inclusive between the date of availability and the completion date, said dates being set forth in the contract, including authorized extensions to the completion date.

101-25 CONTRACT UNIT PRICE.

The unit price for a unit item established in an executed supplemental agreement.

101-26 CONTRACTOR.

The successful Proposer to whom the contract has been awarded, and who has executed the contract documents and furnished acceptable contract bonds.

101-27 CULVERT.

Any structure not classified as a bridge, which provides an opening under the roadway.

101-28 CURRENT CONTROLLING OPERATION OR OPERATIONS.

Any operation or operations, as determined by the Engineer, which if delayed would delay the completion of the project.

101-29 DATE OF AVAILABILITY.

That date set forth in the Request for Proposals, by which it is anticipated that the Contract will be executed and sufficient design efforts or work sites within the project limits will be available for the Design-Builder to begin his controlling operations or design.

101-30 DEPARTMENT OR DEPARTMENT OF TRANSPORTATION.

A principal department of the Executive Branch which performs the functions of planning, design, construction, and maintenance of an integrated statewide transportation system.

101-31 DIVISION OF HIGHWAYS.

The division of the Department of Transportation which, under the direction of the Secretary of Transportation, carries out state highway planning, design, construction, and maintenance functions assigned to the Department of Transportation.

101-32 DRAINAGE EASEMENT.

A right, owned by the Department of Transportation, in a parcel of land owned by a third party outside the highway right of way, to construct and maintain ditches, channels, or structures for directing the course and flow of water outside the highway right of way.

101-33 EASEMENT.

A property right to use or control real property of another.

101-34a. DIRECTOR OF CONSTRUCTION IN LIEU OF CHIEF ENGINEER.

Wherever the term *Chief Engineer or Chief Engineer of Operations* occurs in the Specifications, the actions and responsibilities referred to will be performed by the Director of Construction, Division of Highways, North Carolina Department of Transportation, acting directly or through his duly authorized representative.

101-34b. ENGINEER.

The Chief Engineer of Operations, and/or Director of Construction, Division of Highways, North Carolina Department of Transportation, acting directly or through his duly authorized representatives.

101-35 EQUIPMENT.

All machinery and equipment, together with the necessary supplies, tools, and apparatus for upkeep and maintenance, all of which are necessary for the proper construction and acceptable completion of the work.

101-36 EXTRA WORK.

Work found necessary or desirable to complete fully the work as contemplated in the contract for which payment is not provided for by the contract unit or lump sum prices in the original contract. Extra work shall not be work which in the terms of the specifications and special provisions is incidental to work for which there is a contract price or work for which payment is included in some other contract unit or lump sum price.

101-37 FINAL ACCEPTANCE DATE.

That date on which all work set forth in the contract and work modified by the Engineer is satisfactorily completed excluding any observation periods not specifically made a part of the work by the specifications or special provisions.

101-38 FINAL ESTIMATE.

The document which contains a final statement of all quantities and total dollar amount for each item of work performed during the life of the contract including any adjustments to those amounts made under the terms of the contract. The final statement will be titled The Final Estimate and will be the document utilized to document final payment to the Design-Builder. Receipt of this document by the Design-Builder will begin the time frame for filing of a verified claim with the Department as provided for in G.S. 136-29 of the General Statutes of North Carolina.

101-39 FINAL ESTIMATE ASSEMBLY.

As constructed plans and other project records which establish the final statement of quantities to be paid and document work performed on the project.

101-40 FORCE ACCOUNT NOTICE.

A written notice to the Design-Builder that extra work ordered by the Engineer will be paid for as force account work.

101-41 FORCE ACCOUNT WORK.

Work that is paid for in accordance with Article 109-3 or on the basis of the force account formula provided in the contract.

101-42 HIGHWAY.

A general term denoting a public way for purposes of vehicular travel, including the entire area within the right of way. Synonymous with "Road" and "Street".

101-43 HOUR.

One of the 24 equal parts of a day.

101-44 INSPECTOR.

The authorized representative of the Engineer assigned to make a detailed inspection of any or all portions of the work and materials.

101-45 INTERMEDIATE COMPLETION DATE.

That date set forth in the contract or as revised by authorized extensions, by which date it is required that the portion of work set forth in the contract be satisfactorily completed.

101-46 INTERMEDIATE COMPLETION TIME.

The time set forth in the contract or as revised by authorized extensions, by which it is required that the portion of work set forth in the contract be satisfactorily completed.

101-47 INTERMEDIATE CONTRACT TIME (DAYS).

The number of calendar days inclusive between the date of availability and the completion date, said dates being set forth in the special provisions, including authorized extensions to the intermediate completion date.

101-48 INTERMEDIATE CONTRACT TIME (HOURS).

The number of hours inclusive between the time of availability and the intermediate completion time, said times being set forth in the special provisions, including authorized extensions to the intermediate completion time.

101-49 INVERT.

The lowest point in the internal cross section of a pipe or other culvert.

101-50 INVITATION TO BID.

The notification that proposals will be received for the design and construction of specific projects.

101-51 LABORATORY.

The testing laboratory of the Department of Transportation, Design-Builder, or any other testing laboratory which may be designated or approved by the Engineer.

101-52 LOCAL TRAFFIC.

Traffic which must use the facility under construction in order to reach its destination.

101-53 MAJOR AND MINOR CONTRACT ITEMS.

Major contract items are listed as such in the project special provisions. All other original contract items and extra work shall be considered as minor items.

101-54 MATERIALS.

Any substances which may be incorporated into the construction of the project.

101-55 MEDIAN.

The center section of a divided highway which separates the traffic lanes in one direction from the traffic lanes in the opposite direction.

101-56 PAVEMENT STRUCTURE.

The combination of base and surface courses placed on a subgrade to support the traffic load and distribute it to the roadbed.

101-57 PAY ITEM.

Synonymous with "Contract Item".

101-58 PLANS.

The project plans, Standard Drawings, working drawings and supplemental drawings, or reproductions thereof, accepted by the Engineer, which show the location, character, dimensions and details of the work to be performed.

(A) Standard Drawings:

Drawings approved for repetitive use, showing details to be used where appropriate. All Standard Drawings approved by the Department plus subsequent revisions and additions. Standard Drawings are available for purchase from:

Randy A. Garris, PE
State Contract Officer
1591 Mail Service Center
Raleigh, NC 27699-1591

(B) Preliminary Plans:

Department-furnished drawings included as part of the Design-Build Package.

(C) Project Plans:

Construction drawings prepared, sealed and completed by the Design-Builder. Specific details and dimensions peculiar to the work, which are completed by the Design-Builder.

(D) Working Drawings and Supplemental Drawings:

Supplemental design sheets, shop drawings, or similar data which the Design-Builder is required to submit to the Engineer as described in the Scope of Work.

(E) **As-Constructed Drawings:**

Final drawings prepared by the Design-Builder, documenting the details and dimensions, of the completed work.

101-59 PROJECT.

The specific section of the highway together with all appurtenances, and the design and construction to be performed thereon under the contract.

101-60 PROJECT SPECIAL PROVISIONS.

Special provisions peculiar to the project and not otherwise thoroughly or appropriately set forth in the standard specifications or plans.

101-61 PROPOSAL FORM.

This definition is deleted for this project.

101-62 RIGHT OF WAY.

The land area shown on the plans as right of way within which the project is to be constructed.

101-63 ROAD.

Synonymous with "Highway" and "Street".

101-64 ROADBED.

The graded portion of a highway usually considered as the area between the intersections of top and side slopes, upon which the base course, surface course, shoulders, and median are constructed.

101-65 ROADSIDE.

A general term denoting the area within the limits of the right of way adjoining the outer edge of the roadway. Extensive areas between the roadways of a divided highway may also be considered roadside.

101-66 ROADWAY.

The portion of a highway within limits of construction.

101-67 SECTION.

A numbered chapter of the standard specifications.

101-68 SHOULDER.

The portion of the roadway adjacent to the traveled way for accommodation of stopped vehicles, for emergency use, and for lateral support of base and surface courses.

101-69 SIDEWALK.

That portion of the roadway primarily constructed for pedestrian traffic.

101-70 SKEW ANGLE.

The angle between the centerline of the project and the centerline of a pipe, culvert, bridge pier, bent, abutment, or other drainage feature, measured to the right of the project centerline facing in the direction of progressing stations.

101-71 SPECIAL PROVISIONS.

Project special provisions and standard special provisions taken together as one body of special provisions.

101-72 SPECIFICATIONS.

The general term comprising all the directions, provisions, and requirements contained or referred to in the standard specifications, including the supplemental specifications, together with such additional directions, provisions, and requirements which may be added or adopted as special provisions.

101-73 STANDARD SPECIAL PROVISIONS.

Special directions or requirements not otherwise thoroughly or appropriately set forth in the standard specifications and which are peculiar to a selected group of projects.

101-74 STANDARD SPECIFICATIONS.

The general term comprising all the directions, provisions, and requirements contained or referred to in this book entitled "Standard Specifications for Roads and Structures", and in any subsequent revisions or additions to such book that are issued under the title "Supplemental Specifications".

101-75 STATE.

The State of North Carolina.

101-76 STATION.

A station, when used as a term of measurement, will be 100 linear feet measured horizontally. When used as a location, it will be designated point on the project.

101-77 STREET.

Synonymous with "Highway" and "Road".

101-78 SUBCONTRACTOR.

An individual, partnership, firm, joint venture, or corporation to whom the Design-Builder, with the written consent of the Engineer, sublets any part of the contract.

101-79 SUBGRADE.

That portion of the roadbed prepared as a foundation for the pavement structure including curb and gutter. On portions of projects, which do not include the construction of a base course or pavement, the presence of the subgrade will not be recognized during the life of such contract.

101-80 SUBSTRUCTURE.

All of that part of the structure below the bearings of simple and continuous spans, spans, skew back of arches and tops of footings of rigid frames, together with the backwalls, and wingwalls.

101-81 SUPERINTENDENT.

The representative of the Design-Builder authorized to supervise and direct the construction for the Design-Builder and to receive and fulfill directions from the Engineer.

101-82 SUPERSTRUCTURE.

All of the part of the structure exclusive of the substructure.

101-83 SUPPLEMENTAL AGREEMENT.

A written agreement between the Design-Builder and the Department of Transportation covering amendments to the contract.

101-84 SUPPLEMENTAL SPECIFICATIONS.

General revisions or additions to this book of standard specifications which are issued under the title of "Supplemental Specifications", and which shall be considered as part of the standard specifications; or specifications, regulations, standards, or codes referenced in the contract documents.

101-85 SURETY.

A corporate bonding company furnishing the bid bond or furnishing the contract payment and performance bonds.

101-86 TEMPORARY CONSTRUCTION EASEMENT.

A temporary right, owned by the Department of Transportation, in a parcel of land owned by a third party outside the highway right of way, for the use of the Department of Transportation during the construction and which reverts to the third party on completion of construction.

101-87 THROUGH TRAFFIC.

Traffic which can reach its destination by a route or routes other than the facility under construction.

101-88 TIME OF AVAILABILITY.

That time, set forth in the special provisions, by which it is anticipated that sufficient work sites within the project limits will be available for the Design-Builder to begin his controlling operations.

101-89 TOTAL AMOUNT BID.

Same as total price bid. The total amount bid will be considered to be the correct sum total obtained by adding together the amounts bid for every item in the Design-Build Price proposal.

101-90 UNBALANCED BID.

A bid which includes any unbalanced bid price.

101-91 UNBALANCED BID PRICE.

A unit or lump sum bid price that does not reflect reasonable actual costs which the Proposer anticipates for the performance of the item in question along with a reasonable proportionate share of the Proposer's anticipated profit, overhead costs, and other indirect costs.

101-92 WORK.

Work shall mean the furnishing of all labor, materials, equipment, and incidentals necessary or convenient to the successful completion of the project, or any part, portion, or phase thereof, and the carrying out of all duties and obligations imposed by the contract.

101-93 WORKING DRAWINGS.

Stress sheets, shop drawings, erection drawings, falsework drawings, cofferdam drawings, catalog cuts, or any other supplementary drawings or similar data which the Design-Builder is required to submit to the Engineer for review and/or acceptance.

101-94.1 DESIGN-BUILD.

A form of contracting in which the successful proposer undertakes responsibility for both the design and construction of a project.

101-94.2 DESIGN-BUILDER TEAM.

An individual, partnership, joint venture, corporation or other legal entity that furnishes the necessary design and construction services, whether by itself or through subcontracts.

101-94.3 DESIGN-BUILD PACKAGE.

The documents prepared by the Department for a Design-Build project, containing all forms, information, drawings or other documentation furnished to proposers to guide the preparation and submittal of a proposal for a Design-Build project.

101-94.4 DESIGN-BUILD PROPOSAL.

A proposal to contract consisting of a separately sealed technical proposal and a separately sealed price proposal submitted in response to a request for proposal on a Design-Build project. The technical proposal and price proposal, in some cases, may be scheduled to be submitted on different dates.

101-94.5 DESIGN-BUILD PRICE PROPOSAL.

The part of a Design-Build proposal containing the offer of a Proposer, submitted on the prescribed forms, to perform the work and furnish the labor and materials at the price quoted.

101-94.6 DESIGN-BUILD TECHNICAL PROPOSAL.

A submittal from a proposer, in accordance with requirements of the Design-Build Package, for the purpose of final selection.

101-94.7 PROJECT MANAGER.

The Department's authorized designee responsible for the administration of the Design-Build project.

101-94.8 TECHNICAL SPECIFICATIONS.

Additions and revisions to the Standard Specifications covering conditions and requirements peculiar to a Design-Build project.

101-94.9 TABLE OF VALUES.

A table prepared prior to beginning of construction listing estimated quantity of items for which a testing frequency is defined in the Minimum Sampling Guide. This estimate will be used to determine required frequency of testing for materials and products incorporated into construction, and shall be certified and updated monthly and provided to the Engineer.

SECTION 102
PROPOSAL REQUIREMENTS AND
CONDITIONS

102-1 INVITATION TO BID.

This section is deleted from this project and replaced with the special provision titled "Submittal of Proposals", which discusses the process used to evaluate the Technical and Price proposals.

102-2 PREQUALIFICATION FOR PROPOSERS.

Proposers shall prequalify with the Department. The requirements for prequalification will be furnished each prospective Proposer by the Engineer upon receipt of a written request. A Price Proposal or Technical Proposal will not be opened unless all prequalification requirements have been met by the Proposer and have been found to be acceptable by the Engineer.

In addition to the Experience Questionnaire, prequalification requirements will include provisions for the evaluation of a firm's safety record. A completed 'Safety Index Rating' form must be on file with the Department. To be prequalified to bid each firm must maintain a satisfactory safety index. An overall safety index equal to or greater than 60 is considered satisfactory. In addition, an index between 60 and 69 may be considered marginal and may result in an in-depth safety audit of a firm's safety practices. An overall safety index equal to or less than 59 is considered unsatisfactory and will prohibit prequalification of new firms or the requalification of existing firms at the time of their biennium renewal.

All subcontractors performing work for the Department shall have received a passing grade on the Safety Index Rating form, in accordance with Article 102-2, prior to beginning work. Subcontractors can request the Safety Index Rating form from the State Contractual Services Engineer.

Upon a determination by the Department that all prequalification requirements have been met, the applicant will be assigned a Prequalification Number. This Prequalification Number will thereafter be assigned to all applicants for prequalification or requalification which the Department determines are under sufficient common ownership and management control to warrant prequalification as a single entity. This determination by the Department shall be based on the information submitted with the Experience Questionnaire and any other information obtained by the Department.

No Proposer will be prequalified who, at the time of the application for prequalification is determined by the Engineer to lack the financial capability to complete projects.

Proposers shall comply with all applicable laws regulating the practice of general contracting as contained in Chapter 87 of the General Statutes of North Carolina.

102-3 CONTENTS OF DESIGN-BUILD PACKAGES.

A Design-Build Package will be furnished by the Department to the selected Proposers from among the respondents to the Request for Qualifications. Each Design-Build Package will be marked on the front cover by the Department with an identifier of the Proposer to whom it is being furnished. This package will state the location of the project and will show a schedule of contract items for which Technical and Price proposals are invited. It will set forth the date and

time Technical and Price Proposals are to be submitted and will be opened. The package will also include any special provisions or requirements which vary from or are not contained in any preliminary plans or standard specifications.

The package will also include the printed contract forms and signature sheets for execution by both parties to the contract. In the event the Proposer is awarded the contract, execution of the Design-Build Proposal will be considered the same as execution of the contract by the Proposer.

All papers bound with the package are necessary parts thereof and shall not be detached, taken apart, or altered.

The plans, standard specifications, and other documents designated in the Design-Build package shall be considered a part of the Design-Build package whether attached or not.

Up to 3 copies of the Design-Build Package will be furnished to each prospective Proposer upon request. Additional copies may be purchased for the sum of \$25 each. *The copy marked with the Proposer's name and prequalification number shall be returned to the Department.*

102-4 COMBINATION BIDS.

This section is deleted for this project.

102-5 INTERPRETATION OF QUANTITIES IN PROPOSAL FORM.

This section is deleted for this project.

102-6 EXAMINATION OF PRELIMINARY PLANS, SPECIFICATIONS, CONTRACT, AND SITE OF WORK.

The Proposer shall examine carefully the site of the work contemplated, the preliminary plans and specifications, and the Design-Build Package. The submission of a Technical Proposal and a Price Proposal shall be conclusive evidence that the Proposer has investigated and is satisfied as to the conditions to be encountered; as to the character, quality, and scope of work to be performed; the quantities of materials to be furnished; and as to the conditions and requirements of the proposed contract.

A Proposer is cautioned to make such independent investigation and examination as he deems necessary to satisfy himself as to conditions to be encountered in the performance of the work and with respect to possible local material sources, the quality and quantity of material available from such property, and the type and extent of processing that may be required in order to produce material conforming to the requirements of the specifications.

102-7 SUBSURFACE INFORMATION.

If Subsurface Information is available on this project, a copy of the Subsurface Information may be obtained from the Department. A copy of the Subsurface Information will be mailed to the prospective proposers upon request.

The Subsurface Information and the Subsurface Investigation on which it is based was made for the purpose of information only. The various field boring logs, rock cores, and soil test data available may be reviewed or inspected in Raleigh at the office of the Geotechnical Unit. Neither the Subsurface Information nor the field boring logs, rock cores, or soil test data is part of the contract.

General soil and rock strata descriptions and indicated boundaries are based on a geotechnical interpretation of all available subsurface data and may not necessarily reflect the actual subsurface conditions between borings or between sampled strata within the borehole. The laboratory sample data and the in situ (in-place) test data can be relied on only to the degree of reliability inherent in the standard test method. The observed water levels or soil moisture conditions indicated in the subsurface investigations are as recorded at the time of the investigation. These water levels or soil moisture conditions may vary considerably with time according to climatic conditions including temperature, precipitation, and wind, as well as other non-climatic factors.

THE PROPOSER IS CAUTIONED THAT DETAILS SHOWN ON THE SUBSURFACE INFORMATION ARE PRELIMINARY ONLY. THE DEPARTMENT DOES NOT WARRANT OR GUARANTEE THE SUFFICIENCY OR ACCURACY OF THE INVESTIGATION MADE, NOR THE INTERPRETATIONS MADE OR OPINIONS OF THE DEPARTMENT AS TO THE TYPE OF MATERIALS AND CONDITIONS TO BE ENCOUNTERED. THE PROPOSER IS CAUTIONED TO MAKE SUCH INDEPENDENT SUBSURFACE INVESTIGATIONS AS THEY DEEM NECESSARY TO SATISFY THEIRSELF AS TO CONDITIONS TO BE ENCOUNTERED ON THIS PROJECT. THE PROPOSER SHALL HAVE NO CLAIM FOR ADDITIONAL COMPENSATION OR FOR AN EXTENSION OF TIME FOR ANY REASON RESULTING FROM THE ACTUAL CONDITIONS ENCOUNTERED AT THE SITE DIFFERING FROM THOSE INDICATED IN THE SUBSURFACE INFORMATION.

102-8 PREPARATION AND SUBMISSION OF PRICE PROPOSALS .

All Price Proposals shall be prepared and submitted in accordance with the following listed requirements:

1. The Design-Build Package provided by the Department shall be used and shall not be taken apart or altered. The Price Proposal shall be submitted on the same form, which has been furnished to the Proposer by the Department as identified by the Proposer's name marked on the front cover by the Department.
2. All entries including signatures shall be written in ink.
3. The Proposer shall submit a lump sum price for every item in the Design-Build Price Proposal. The lump sum prices bid for the various contract items shall be written in figures.
4. An amount bid shall be entered in the Design-Build Package for every lump sum item and the price shall be written in figures in the "Amount Bid" column in the Design-Build Package.
5. The total amount bid shall be written in figures in the proper place in the Design-Build Package. The total amount bid shall be determined by adding the amounts bid for each lump sum item.
6. Changes in any entry shall be made by marking through the entry in ink and making the correct entry adjacent thereto in ink. A representative of the Proposer shall initial the change in ink.

7. The Price Proposal shall be properly executed. In order to constitute proper execution, the Price Proposal shall be executed in strict compliance with the following:
 - a. If a Price Proposal is by an individual, it shall show the name of the individual and shall be signed by the individual with the word "Individually" appearing under the signature. If the individual operates under a firm name, the bid shall be signed in the name of the individual doing business under the firm name.
 - b. If the Price Proposal is by a corporation, it shall be executed in the name of the corporation by the President, Vice President, or Assistant Vice President. It shall be attested by the Secretary or Assistant Secretary. The seal of the corporation shall be affixed. If the Price Proposal is executed on behalf of a corporation in any other manner than as above, a certified copy of the minutes of the Board of Directors of said corporation authorizing the manner and style of execution and the authority of the person executing shall be attached to the Price Proposal or shall be on file with the Department.
 - c. If the Price Proposal is made by a partnership, it shall be executed in the name of the partnership by one of the general partners.
 - d. If the Price Proposal is a joint venture, it shall be executed by each of the joint venturers in the appropriate manner set out above. In addition, the execution by the joint venturers shall appear below their names.
 - e. The Price Proposal execution shall be notarized by a notary public whose commission is in effect on the date of execution. Such notarization shall be applicable both to the Price Proposal and to the non-collusion affidavit which is part of the signature sheets.
8. The Price Proposal shall not contain any unauthorized additions, deletions, or conditional bids.
9. The Proposer shall not add any provision reserving the right to accept or reject an award, or to enter into a contract pursuant to an award.
10. The Price Proposal shall be accompanied by a bid bond on the form furnished by the Department or by a bid deposit. The bid bond shall be completely and properly executed in accordance with the requirements of Article 102-11. The bid deposit shall be a certified check or cashier check in accordance with Article 102-11.
11. The Price Proposal shall be placed in a sealed envelope and shall have been delivered to and received by the Department prior to the time specified in the Design-Build Package.

102-9 COMPUTER BID PREPARATION.

This section is deleted from this project.

102-10 NON-COLLUSION AFFIDAVIT.

In compliance with Section 112(c) of title 23 USC, and current regulations of the Department, each and every Proposer will be required to furnish the Department with an affidavit certifying that the Proposer has not entered into any agreement, participated in any collusion, or otherwise taken any action in restraint of free competitive bidding in connection with his Price Proposal on the project. The affidavit shall also conclusively indicate that the

Proposer intends to do the work with its own bonafide employees or subDesign-Builders and is not bidding for the benefit of another Design-Builder.

Affidavit forms will be included in the Design-Build Package as part of the signature sheets. Execution of the signature sheets will also constitute execution of the non-collusion affidavit. The signature sheets shall be notarized.

102-11 BID BOND OR BID DEPOSIT.

Each Price proposal shall be accompanied by a corporate bid bond or a bid deposit of a certified or cashiers check in the amount of at least 5% of the total amount bid for the contract. No Price proposal will be considered or accepted unless accompanied by one of the foregoing securities. The bid bond shall be executed by a Corporate Surety licensed to do business in North Carolina and the certified check or cashiers check shall be drawn on a bank or trust company insured by the Federal Deposit Insurance Corporation and made payable to the Department of Transportation in an amount of at least 5% of the total amount bid for the contract. The condition of the bid bond or bid deposit is: the Principal shall not withdraw its Price proposal within 60 days after the opening of the same, and if the Board of Transportation shall award a contract to the Principal, the Principal shall within 14 calendar days after the notice of award is received by him give payment and performance bonds with good and sufficient surety as required for the faithful performance of the contract and for the protection of all persons supplying labor and materials in the prosecution of the work; in the event of the failure of the Principal to give such payment and performance bonds as required, then the amount of the bid bond shall be immediately paid to the Department as liquidated damages or, in the case of a bid deposit, the deposit shall be forfeited to the Department.

Withdrawal of a Price proposal due to a mistake made in the preparation of the Price proposal, where permitted by Article 103-3, shall not constitute withdrawal of a Price proposal as cause for payment of the bid bond or forfeiture of the bid deposit.

When a Price proposal is secured by a bid bond, the bid bond shall be on the form furnished by the Department. The bid bond shall be executed by both the Proposer and a Corporate Surety licensed under the laws of North Carolina to write such bonds. The execution by the Proposer shall be in the same manner as required by Article 102-8 for the proper execution of the Price proposal. The execution by the Corporate Surety shall be the same as is provided for by Article 102-8, Item 7b, for the execution of the Price proposal by a corporation. The seal of the Corporate Surety shall be affixed to the bid bond. The bid bond form furnished is for execution of the Corporate Surety by a General Agent or Attorney in Fact. A certified copy of the Power of Attorney shall be attached if the bid bond is executed by a General Agent or Attorney in Fact. The Power of Attorney shall contain a certification that the Power of Attorney is still in full force and effect as of the date of the execution of the bid bond by the General Agent or Attorney in Fact. If the bid bond is executed by the Corporate Surety by the President, Vice President, or Assistant Vice President, and attested to by the Secretary or Assistant Secretary, then the bid bond form furnished shall be modified for such execution, instead of execution by the Attorney in Fact or the General Agent.

When a Price proposal is secured by a bid deposit (certified check or cashiers check), the execution of a bid bond will not be required.

If the Proposer has failed to meet all conditions of the bid bond but the Department has not received the amount due under the bid bond, the Proposer may be disqualified from further bidding as provided in Article 102-16.

102-12 DELIVERY OF PROPOSALS.

All Price Proposals shall be placed in a sealed envelope having the name and address of the Proposer, and the statement " Price Proposal for the Design/Build of State Highway Project No. _____ in _____ County(ies)" on the outside of the envelope. If delivered by mail, the sealed envelope shall be placed in another sealed envelope and the outer envelope addressed to the Contract Officer as stated in the Design-Build Package. The outer envelope shall also bear the statement " Price Proposal for the Design/Build of State Highway Project No. _____". All Technical Proposals shall be placed in a sealed envelope having the name and address of the Proposer, and the statement " Technical Proposal for the Design/Build of State Highway Project No. _____ in _____ County(ies)" on the outside of the envelope. If delivered by mail, the sealed envelope shall be placed in another sealed envelope and the outer envelope addressed to the Contract Officer as stated in the Design-Build Package. The outer envelope shall also bear the statement " Technical Proposal for the Design/Build of State Highway Project No. _____". If delivered in person on or before the due date, the sealed envelope shall be delivered to the office of the Contract Officer as indicated in the Design-Build Package. Price Proposals and Technical Proposals shall be submitted in accordance with the project special provision "Submittal of Proposals" contained elsewhere in this Design-Build package.

All Price Proposals and Technical Proposals shall be delivered prior to the time specified in the Design-Build Package. Price proposals and Technical Proposals received after such time will not be accepted and will be returned to the Proposer unopened.

102-13 WITHDRAWAL OR REVISION OF PROPOSALS.

A Design-Build proposer will not be permitted to withdraw its Technical and Price proposals after they have been submitted to the Department.

102-14 RECEIPT AND OPENING OF PROPOSALS.

Price Proposals will be opened and read publicly at the time and place indicated in the Design-Build Package. The scores of the previously conducted evaluation of the Technical Proposals will also be read publicly at this time. Proposers, their authorized agents, and other interested parties are invited to be present.

102-15 REJECTION OF PRICE PROPOSALS.

Any Price proposal submitted which fails to comply with any of the requirements of Article 102-8, 102-11, or with the requirements of the project scope and functional specifications shall be considered irregular and may be rejected.

Irregularities due to apparent clerical errors and omissions may be waived in accordance with Article 103-2.

Any Price proposal including any unit or lump sum bid price, which is significantly unbalanced to the potential detriment of the Department, will be considered irregular and may be rejected. In the event the Board determines it is in the best public interest to accept such

irregular Price proposal, it may award the contract based on such Price proposal subject to the provisions of Subarticle 109-4(B).

A Price proposal, which does not contain costs for all proposal items, shall be considered irregular and may be rejected.

In addition to the above, any Price proposals for contracts not funded with any Federal funds which are submitted by any Proposer who has failed to obtain the appropriate General Contractor's license, as required by Chapter 87 of the General Statutes of North Carolina, shall be considered irregular and will not be considered for award.

The right to reject any and all Proposals shall be reserved to the Board.

102-16 DISQUALIFICATION OF PROPOSERS.

Any one of the following causes may be justification for disqualifying a Proposer from further bidding until he has applied for and has been requalified in accordance with Article 102-2:

1. Unsatisfactory progress in accordance with Article 108-8.
2. Being declared in default in accordance with Article 108-9.
3. Uncompleted contracts which, in the judgment of the Chief Engineer, might hinder or prevent the timely completion of additional work if awarded.
4. Failure to comply with prequalification requirements.
5. The submission of more than one Price proposal for the same contract by an individual, partnership, joint venture, or corporation prequalified under the same prequalification number.
6. Evidence of collusion among Proposers. Each participant in such collusion will be disqualified.
7. Failure to furnish a non-collusion affidavit upon request.
8. Failure to comply with Article 108-6.
9. Failure to comply with a written order of the Engineer as provided in Article 105-1 if in the judgment of the Chief Engineer such failure is of sufficient magnitude to warrant disqualification.
10. Failure to satisfy the Disadvantaged Business Enterprise requirements of the project special provisions.
11. The Department has not received the amount due under a forfeited bid bond or under the terms of a performance bond.
12. Failure to submit within 60 days after being requested by the Engineer, or the submission of false information in, the documents required by Article 109-9.
13. Failure to return overpayments as directed by the Engineer.
14. Recruitment of Department employees as prohibited by Article 108-5.
15. Failure to maintain a satisfactory safety index as required by Article 102-2.

Upon a determination that a Proposer should be disqualified for one or more of the reasons listed above, the Department may, at its discretion, remove all entities prequalified under the same Prequalification Number.

SECTION 103**AWARD AND EXECUTION OF CONTRACT****103-1 CONSIDERATION OF PRICE PROPOSALS.**

After the Price proposals are opened and read, they will be tabulated. The Price proposal and score of the technical proposal will be made available to the public. In the event of errors, omissions, or discrepancies in the costs, corrections to the Price proposal will be made in accordance with the provisions of Article 103-2. Such corrected costs will be used to determine the lowest adjusted price.

After the reading of the Price proposals and technical scores, the Department will calculate the lowest adjusted price as described in the "Special Provision for Instructions to Proposers".

The right is reserved to reject any or all Price proposals, to waive technicalities, to request the Proposer with the lowest adjusted price to submit an up-to-date financial and operating statement, to advertise for new proposals, or to proceed to do the work otherwise, if in the judgment of the Board, the best interests of the State will be promoted thereby.

103-2 CORRECTION OF PRICE PROPOSAL ERRORS.**(A) General:**

The provisions of this article shall apply in waiving irregularities and correcting apparent clerical errors and omissions in the "amount bid" and "total amount bid" for bid items.

(B) Discrepancy in the "Total Amount Bid" and the addition of the "Amount Bid" for each line Item.

In the case of the Total Amount Bid does not equal the summation of each Amount Bid for the line items, the Total Amount Bid shall be deemed to be the correct total for the entire project.

(C) Omitted Total Amount Bid –Amount Bid Completed

If the Total Amount Bid is not completed and the Amount Bid for all line items is completed the Total Amount Bid shall be the summation of the Amount Bid for all line items.

103-3 WITHDRAWAL OF PRICE PROPOSAL -MISTAKE.**(A) Criteria for Withdrawal of Price Proposal:**

The Department of Transportation may allow a Proposer submitting a Price proposal to withdraw his Price proposal after the scheduled time of Price proposal opening upon a determination that:

1. A mistake was in fact made in the preparation of the Price proposal.
2. The mistake in the Price proposal is of a clerical or mathematical nature and not one of bad judgment, carelessness in inspecting the work site, or in interpreting the functional requirements.
3. The mistake is found to be made in good faith and was not deliberate or by reason of gross negligence.

4. The amount of the error or mistake is equal to or greater than 3 percent of the total amount of Price proposal.
5. The Proposer's notice of his mistake and request for withdrawal of the Price proposal by reason of the mistake was promptly communicated to the Chief Engineer and in no instance longer than 48 hours after the scheduled time of Price proposal opening. If the Proposer notifies the Chief Engineer verbally, written notice of mistake must be submitted within 48 hours to the Chief Engineer accompanied by copies of Price proposal preparation information.
6. The Department of Transportation will not be prejudiced or damaged except for the loss of the Price proposal.

(B) Hearing by Chief Engineer:

If a Proposer files a notice of mistake along with a request to withdraw his Price proposal, the Chief Engineer (or his designee) will promptly hold a hearing thereon. The Chief Engineer will give to the requesting Proposer reasonable notice of the time and place of any such hearing. The Proposer may appear at the hearing and present the original working papers, documents, or materials used in the preparation of the Price proposal sought to be withdrawn, together with other facts and arguments in support of his request to withdraw his Price proposal. The Proposer will be required to present a written affidavit that the documents presented are the original, unaltered documents used in the preparation of the Price proposal.

(C) Action by State Highway Administrator:

A determination may be made by the Administrator that the Proposer meets the criteria for withdrawal of the Price proposal as set forth in Subarticle 103-3(A) upon presentation of clear and convincing evidence by the Proposer. The Chief Engineer will present his findings to the State Highway Administrator for action on the Proposer's request. The Chief Engineer will advise the Proposer of the Administrator's decision prior to the Board of Transportation's consideration of award.

(D) Bid Bond:

If a bid mistake is made and a request to withdraw the Price proposal is made, the bid bond shall continue in full force and effect until there is a determination by the Administrator that the conditions in Subarticle 103-3(A) have been met. The effect of the refusal of the Proposer to give payment and performance bonds within 14 calendar days after the notice of award is received by him, if award has been made by the Board of Transportation after consideration and denial of the Proposer's request to withdraw his Price proposal, shall be governed by the terms and conditions of the bid bond.

103-4 AWARD OF CONTRACT.

(A) General:

The North Carolina Department of Transportation, in accordance with the provisions of Title VI of the Civil Rights Act of 1964 (78 Stat. 252) and the Regulations of the Department of Transportation (49 CFR, Part 21), issued pursuant to such act, hereby notifies all proposers that it will affirmatively insure that contracts entered in pursuant to this Request for Proposals, if awarded, will be made by the Board of Transportation to the Proposer with the lowest adjusted price as outlined in the Design-Build package without discrimination on the grounds of race,

color, or national origin. The Proposer with the lowest adjusted price will be notified by letter that his proposal has been accepted and that he has been awarded the contract. This letter shall constitute the notice of award. The notice of award, if the award be made, will be issued within 60 days after the opening of Price proposals, except that with the consent of the Proposer with the lowest adjusted price the decision to award the contract to such Proposer may be delayed for as long a time as may be agreed upon by the Department and such Proposer. In the absence of such agreement, the Proposer with the lowest adjusted price may withdraw his proposal at the expiration of the 60 days without penalty if no notice of award has been issued.

Award of a contract involving any unbalanced bid price(s) may be made in accordance with the provisions of Article 102-15.

103-5 CANCELLATION OF AWARD.

The Board of Transportation reserves the right to rescind the award of any contract at any time before the receipt of the properly executed contract bonds from the successful Proposer.

103-6 RETURN OF BID BOND OR BID DEPOSIT.

All bid bonds will be retained by the Department until the contract bonds are furnished by the successful Proposer, after which all such bid bonds will be destroyed unless the individual bid bond form contains a note requesting that it be returned to the Proposer or the Surety.

Checks which have been furnished as a bid deposit will be retained until after the contract bonds have been furnished by the successful Proposer, at which time Department of Transportation warrants in the equivalent amount of checks which were furnished as a bid deposit will be issued.

103-7 CONTRACT BONDS.

The successful Proposer, within 14 calendar days after the notice of award is received by him, shall provide the Department with a contract payment bond and a contract performance bond each in an amount equal to 100 percent of the amount of the contract. All bonds shall be in conformance with G.S. 44A-33. The corporate surety furnishing the bonds shall be authorized to do business in the State

103-8 EXECUTION OF CONTRACT.

As soon as possible following receipt of the properly executed contract bonds, the Department will complete the execution of the contract, retain the original contract, and return one certified copy of the contract to the Proposer.

103-9 FAILURE TO FURNISH CONTRACT BONDS.

The successful Proposer's failure to file acceptable bonds within 14 calendar days after the notice of award is received by him shall be just cause for the forfeiture of the bid bond or bid deposit and rescinding the award of the contract. Award may then be made to the Proposer with the next lowest adjusted price Proposer or the work may be readvertised and constructed under contract or otherwise, as the Board of Transportation may decide.

SECTION 104
SCOPE OF WORK

104-1 INTENT OF CONTRACT.

The intent of the contract is to prescribe the work or improvements which the Design-Builder undertakes to perform, in full compliance with the contract. In case the method or character of any part of the work is not covered by the contract, this section shall apply. The Design-Builder shall perform all work in accordance with the contract or as may be modified by written orders, and shall do such special, additional, extra, and incidental work as may be considered necessary to complete the work to the full intent of the contract. Unless otherwise provided elsewhere in the contract, the Design-Builder shall furnish all implements, machinery, equipment, tools, materials, supplies, transportation, and labor necessary for the design, prosecution and completion of the work.

104-2 SUPPLEMENTAL AGREEMENTS.

Whenever it is necessary to make amendments to the contract to satisfactorily complete the proposed design and construction and/or to provide authorized time extensions, the Engineer shall have the authority to enter into a supplemental agreement covering such amendments.

Supplemental agreements shall become a part of the contract when executed by the Engineer and an authorized representative of the Design-Builder. The Design-Builder shall file with the Engineer a copy of the name or names of his representatives who are authorized to sign supplemental agreements.

104-3 ALTERATIONS OF CONTRACT

The Engineer reserves the right to make, at any time during the progress of the work, such alterations in the contract as may be found necessary or desirable. Under no circumstances will an alteration involve work beyond the termini of the proposed construction except as may be necessary to satisfactorily complete the project. Such alterations shall not invalidate the contract nor release the Surety, and the Design-Builder agrees to perform the work as altered at his contract unit or lump sum prices the same as if it had been a part of the original contract except as otherwise herein provided.

An adjustment in the affected contract unit or lump sum prices due to alterations in the contract that materially change the character of the work and the cost of performing the work will be made by the Engineer only as provided in this article.

If the Engineer makes an alteration in the contract that he determines will materially change the character of the work and the cost of performing the work, an adjustment will be made and the contract modified in writing accordingly. The Design-Builder will be paid for performing the affected work in accordance with Subarticle 104-8(A).

When the Design-Builder is required to perform work, which is, in his opinion, an alteration in the contract that materially changes the character of the work and the cost of performing the work, he shall notify the Engineer in writing prior to performing such work. The Engineer will investigate and, based upon his determination, one of the following will occur:

1. If the Engineer determines that the affected work is an alteration of the plans or details of construction that materially changes the character of contract, the Design-Builder will

be notified in writing by the Engineer and compensation will be made in accordance with Subarticle 104-8(A).

2. If the Engineer determines that the work is not such an alteration in the contract that materially changes the character of the work and the cost of performing the work, he will notify the Design-Builder in writing of his determination. If the Design-Builder, upon receipt of the Engineer's written determination, still intends to file a claim for additional compensation by reason of such alteration, he shall notify the Engineer in writing of such intent prior to beginning any of the alleged altered work and the provisions of Subarticle 104-8(B) shall be strictly adhered to.

No contract adjustment will be allowed under this article for any effects caused on unaltered work.

104-4 SUSPENSIONS OF WORK ORDERED BY THE ENGINEER.

(A) Suspensions of the Work Ordered by the Engineer:

When the Engineer suspends in writing the performance of all or any portion of the work for a period of time not originally anticipated, customary, or inherent to the construction industry and the Design-Builder believes that additional compensation for idle equipment and/or labor is justifiably due as a result of such suspension, the Design-Builder shall notify the Engineer in writing of his intent to file a claim for additional compensation within 7 days after the Engineer suspends the performances of the work and the provisions of Subarticle 104-8 (C) shall be strictly adhered to.

Within 14 calendar days of receipt by the Design-Builder of the notice to resume work, the Design-Builder shall submit his claim to the Engineer in writing. Such claim shall set forth the reasons and support for such adjustment in compensation, including cost records, and any other supporting justification in accordance with Subarticle 104-8(C).

(B) Alleged Suspension:

If the Design-Builder contends he has been prevented from performing all or any portion of the work for a period of time not originally anticipated, customary, or inherent to the construction industry because of conditions beyond the control of and not the fault of the Design-Builder, its suppliers, or subcontractors at any tier, and not caused by weather, but the Engineer has not suspended the work in writing, the Design-Builder shall submit in writing to the Engineer a notice of intent to file a claim for additional compensation by reason of such alleged suspension. No adjustment in compensation will be allowed for idle equipment and/or labor prior to the time of the submission of the written notice of intent to file a claim for additional compensation by reason of such alleged suspension. Upon receipt, the Engineer will evaluate the Design-Builder's notice of intent to file a claim for additional compensation. If the Engineer agrees with the Design-Builder's contention, the Engineer will suspend in writing the performance of all or any portion of the work and the provisions of Subarticle 104-8(C) shall be strictly adhered to.

If the Engineer does not agree with the Design-Builder's contention as described above and determines that no portion of the work should be suspended, he will notify the Design-Builder in writing of his determination. If the Design-Builder does not agree with the Engineer's determination, the provisions of Subarticle 104-8(C) shall be strictly adhered to. Within 14 calendar days after the last day of the alleged-suspension, the Design-Builder shall submit his

claim to the Engineer in writing. Such claim shall set forth the reasons and support for such adjustment in compensation, including cost records, and any other supporting justification in accordance with Subarticle 104-8(C).

(C) Conditions:

No adjustment in compensation will be allowed under Subarticles 104-4(A) and 104-4(B) for any reason whatsoever for each occurrence of idle equipment and/or idle labor which has a duration of twenty-four hours or less.

No adjustment in compensation will be allowed under Subarticles 104-4(A) and 104-4(B) to the extent that performance would have been suspended by any other cause, or for which an adjustment is provided for or excluded under any other term or condition of this contract.

No adjustment in compensation will be allowed under Subarticles 104-4(A) and 104-4(B) for any effects caused on unchanged work. No adjustment in compensation will be allowed under Subarticles 104-4(A) and 104-4(B) except for idle equipment and/or idle labor resulting solely from the suspension of work in writing by the Engineer.

No adjustment in compensation will be allowed under Subarticles 104-4(A) and 104-4(B) where temporary suspensions of the work have been ordered by the Engineer in accordance with Article 108-7 and the temporary suspensions are a result of the fault or negligence of the Design-Builder.

104-7 EXTRA WORK.

The Design-Builder shall perform extra work whenever it is deemed necessary or desirable to complete fully the work as contemplated. Extra work shall be performed in accordance with the specifications and as directed by the Engineer. No extra work shall be commenced prior to specific authorization for the performance of such extra work being given by the Engineer.

Extra work which is specifically authorized by the Engineer will be paid for in accordance with Subarticle 104-8(A).

When the Design-Builder is required to perform work which is in his opinion extra work, he shall notify the Engineer in writing prior to performing such work. The Engineer will investigate and, based upon his determination, one of the following will occur.

1. If the Engineer determines that the affected work is extra work, the Design-Builder will be notified in writing by the Engineer and compensation will be made in accordance with Subarticle 104-8(A).
2. If the Engineer determines that the work is not extra work, he will notify the Design-Builder in writing of his determination. If the Design-Builder upon receipt of the Engineer's written determination intends to file a claim for additional compensation by reason of such work, he shall notify the Engineer in writing of such intent prior to beginning any of the alleged extra work and the provisions of Subarticle 104-8(B) shall be strictly adhered to.

104-8 COMPENSATION AND RECORD KEEPING.**(A) Compensation--Article 104-3 and Article 104-7:**

When the Engineer and Design-Builder agree that compensation is due under the provisions of Articles 104-3 or 104-7, payment will be made in accordance with one of the following:

1. When the Engineer and the Design-Builder agree to the prices to be paid, the agreement will be set forth in a supplemental agreement. If the estimated total cost of the affected work is equal to or less than \$25,000.00 and the prices for performing the work have been mutually agreed to, the Design-Builder may begin work before executing the supplemental agreement. If the estimated total cost of the affected work is more than \$25,000.00; the Design-Builder shall not begin the affected work until the supplemental agreement is executed.
2. When the Engineer and the Design-Builder cannot agree to the prices to be paid for the affected work, the Engineer will issue a force account notice prior to the Design-Builder beginning work. In this instance the affected work shall be performed as directed by the Engineer and paid for in accordance with the provisions of Article 109-3.

(B) Claim for Additional Compensation--Article 104-3 and Article 104-7:

The Design-Builder's notice of intent to file a claim for additional compensation under the provisions of Articles 104-3 and 104-7 shall be given to the Engineer in writing. The Design-Builder shall keep accurate and detailed cost records in accordance with the provisions of Article 109-3. The Design-Builder's cost records and supporting data shall be complete in every respect and in such form that the Engineer may check them. The Design-Builder's cost records and supporting data shall clearly indicate the cost of performing the work in dispute and shall separate the cost of any work for which payment has been made. The Design-Builder's cost records shall be kept up to date and the Engineer shall be given the opportunity to review the methods by which the records are being maintained. The cost records shall be prepared on a weekly basis for each occurrence for which notice of intent to file a claim has been given and submitted to the Engineer within 7 days after the end of a given weekly period.

If the Design-Builder chooses to pursue the claim after the disputed work is complete, he shall submit a written claim to the Engineer for an adjustment in compensation based upon his cost records within 120 calendar days after completion of the disputed work. This claim shall summarize previously submitted cost records and clearly describe the Design-Builder's justification for an adjustment in compensation under the terms of the contract.

Upon receipt, the Engineer will review the Design-Builder's request and supporting documentation.

If the Engineer determines that the work covered by the claim is in fact compensable under the terms of the contract, an adjustment in compensation will be made based upon the documentation presented and his engineering judgment. The adjustment will be made on the next partial pay estimate and reflected on the final estimate. The compensation allowed shall be limited to the amount that would be paid if the work were performed in accordance with Article 109-3.

If the Engineer determines that the work covered by the claim is not compensable under the terms of the contract, the claim will be denied.

The Engineer will notify the Design-Builder of his determination whether or not an adjustment of the contract is warranted within 120 calendar days after receipt of the complete request, all necessary supporting justification, and cost records.

The failure on the part of the Design-Builder to perform any of the following shall be a bar to recovery under the provisions of Articles 104-3 or 104-7:

1. The failure of the Design-Builder to notify the Engineer in writing prior to performing the work in dispute that he intends to file a claim.
2. The failure of the Design-Builder to keep records in accordance with the provisions of Article 109-3.
3. The failure of the Design-Builder to give the Engineer the opportunity to monitor the methods by which records are being maintained.

The failure of the Design-Builder to submit additional documentation requested by the Engineer provided documentation requested is available within the Design-Builder's records.

The failure of the Design-Builder to submit cost records on a weekly basis.

The failure of the Design-Builder to submit the written request for an adjustment in compensation with cost records and supporting information within 120 calendar days of completion of the affected work.

(C) Compensation--Article 104-4:

The Design-Builder's notice of intent to file a claim for additional compensation under the provisions of Subarticle 104-4(A) shall be given to the Engineer in writing within 7 days after the Engineer suspends the performance of the work. For an alleged suspension, the Design-Builder's notice of intent to file a claim for additional compensation under the provisions of Subarticle 104-4(B) shall be given to the Engineer in writing. The Design-Builder shall keep accurate and detailed records of the equipment and labor alleged to be idle. The Design-Builder's cost records, supporting data, and supporting information shall be complete in every respect and in such form that the Engineer may check them. The Design-Builder's cost records, supporting data, and supporting information for equipment idled due to the suspension or alleged suspension shall specifically identify each individual piece of equipment, its involvement in the work, its location on the project, the requested rental rate and justification as to why the equipment cannot be absorbed into unaffected work on the project during the period of suspension or alleged suspension. The Design-Builder's cost records, supporting data, and supporting information for idle labor shall include the specific employees, classification, dates and time idled, hourly rate of pay, their involvement in the project, and justification as to why they cannot be absorbed into the unaffected work on the project or other projects during the period of suspension or alleged suspension. The Design-Builder's cost records, supporting data, and supporting information shall be kept up-to-date and the Engineer shall be given the opportunity to review the methods by which the records, data, and information are being maintained. The cost records, supporting data, and supporting information shall be prepared on a weekly basis for each occurrence for which notice of intent to file a claim has been given and submitted to the Engineer within 7 days after the end of a given weekly period.

If the Design-Builder choose to pursue the claim after the suspension or alleged suspension period has ended, he shall submit a written claim to the Engineer for an adjustment in compensation based upon his cost records due to idle equipment and/or idle labor within 14 calendar days or receipt of the notice to resume work or within 14 calendar days of expiration of the alleged suspension period. This request shall summarize previously submitted cost records and clearly describe the Design-Builder's justification for an adjustment in compensation under the terms of the contract.

Upon receipt, the Engineer will evaluate the Design-Builder's request. If the Engineer agrees that the cost of the work directly associated with the suspension or alleged suspension has increased as a result of such suspension or alleged suspension and the suspension or alleged suspension was caused by conditions beyond the control of and not the fault of the Design-Builder, its suppliers, or subcontractors at any approved tier, and not caused by weather, the Engineer will make an adjustment, excluding profit, and modify the contract in writing accordingly. The Design-Builder will be paid for the verified actual cost of the idle equipment and idle labor. The compensation allowed shall be limited to the equipment, labor, bond, insurance, and tax costs, excluding profits, computed in accordance with Article 109-3.

If the Engineer determines that the suspensions of the work by the Engineer or alleged suspensions do not warrant an adjustment in compensation, he will notify the Design-Builder in writing of his determination.

The Engineer will notify the Design-Builder of his determination of whether or not an adjustment in compensation is warranted within 120 calendar days after receipt of the complete request, all necessary supporting justification, and cost records.

The failure on the part of the Design-Builder to perform any of the following shall be a bar to recovery under the provisions of Article 104-4:

1. The failure to notify the Engineer in writing within 7 days after the Engineer suspends in writing the performance of all or any portion of the work.
2. The failure to notify the Engineer in writing that he intends to file a claim by reason of alleged suspension.
3. The failure of the Design-Builder to keep records in accordance with the details of Article 109-3.
4. The failure of the Design-Builder to give the Engineer the opportunity to monitor the methods by which records are being maintained.
5. The failure of the Design-Builder to submit additional documentation requested by the Engineer provided documentation requested is available within the Design-Builder's records.
6. The failure of the Design-Builder to submit cost records on a weekly basis.
7. The failure of the Design-Builder to submit the written request for an adjustment in compensation with cost records, supporting data, and supporting information within 14 calendar days of receipt of the notice to resume work.

8. The failure of the Design-Builder to submit the written request for an adjustment in compensation with cost records, supporting data, and supporting information within 14 calendar days after the last day of the period during which the Design-Builder contends he has been prevented from performing all or any portion of the work for an unreasonable period of time (not originally anticipated, customary, or inherent to the construction industry) because of conditions beyond the control of and not the fault of the Design-Builder, its suppliers, or subcontractors at any approved tier, and not caused by weather.

(D) Notification of Determination:

The failure on the part of the Engineer to notify the Design-Builder of his determination on the requested adjustment in compensation within 120 calendar days after receipt of the complete request, all supporting justification, and cost records will result in payment of interest on any monies determined to be due from the requested adjustment in compensation. Interest, at the average rate earned by the State Treasurer on the investment within the State's Short Term Fixed Income Investment Fund during the month preceding the date interest becomes payable, will be paid the Design-Builder on the next partial pay estimate and reflected on the final estimate for the period beginning on the 121st day after receipt of the complete request, all supporting justification, and cost records, and extending to the date the Engineer makes his determination on the disputed work.

If the Design-Builder fails to receive such adjustment in compensation for the disputed work as he claims to be entitled to under the terms of the contract, the Design-Builder may resubmit the written request for an adjustment in compensation to the Engineer as a part of the final claim after the project is complete. The Design-Builder will only be allowed to submit the request for an adjustment in compensation one time during the construction of the project.

104-9 DISPOSITION OF SURPLUS PROPERTY.

All property that is surplus to the needs of the project will remain or become the property of the Design-Builder, unless otherwise stated in the plans or special provisions, with the following exceptions:

1. Materials which are the property of utility companies providing service to buildings which are to be demolished or removed in accordance with Sections 210 and 215.
2. Materials resulting from the removal of existing pavement in accordance with Section 250 which are to be stockpiled for the use of the Department.
3. Materials resulting from the removal of existing structures in accordance with Section 402 where the plans or special provisions indicate that the material will remain the property of the Department.
4. Aggregate base course where the Special Provisions require that this material become the property of the Department.
5. Left over materials for which the Department has reimbursed the Design-Builder as provided in Article 109-6.
6. Materials that have been furnished by the Department for use on the project.

Property shall include but not be limited to materials furnished by the Design-Builder or the Department for either temporary or permanent use on the project, salvaged materials which were part of the existing facility on the date of availability for the project, and all implements, machinery, equipment, tools, supplies, laboratories, field offices, and watercraft which are necessary for the satisfactory completion of the project.

All property of the Design-Builder shall be removed from the project by the Design-Builder prior to final acceptance.

104-10 MAINTENANCE OF THE PROJECT.

The Design-Builder shall maintain the project from the date of beginning construction until the project is finally accepted. This maintenance shall be continuous and effective and shall be prosecuted with adequate equipment and forces to the end that all work covered by the contract is kept in satisfactory and acceptable condition at all times.

The Design-Builder shall maintain all existing drainage facilities, except where the work consists of resurfacing only, such that they are in the same condition upon acceptance of the project as they were when the project was made available.

In the event that the Design-Builder's work is suspended for any reason, he shall maintain the work covered by the contract, as provided herein.

When a portion of the project is accepted as provided in Article 105-17, immediately after such acceptance the Design-Builder will not be required to maintain the accepted portions. Should latent defects be discovered or become evident in an accepted portion of the project, such defective work shall be repaired or replaced at no cost to the Department.

Where an observation period(s) is required that extends beyond the final acceptance date, the Design-Builder shall perform any work required by the observation period until satisfactory completion of the observation period. The Design-Builder will not be directly compensated for any maintenance operations necessary, as this work will be considered incidental to the work covered by the various contract items.

104-11 FINAL CLEANING UP.

Before acceptance of the work for maintenance, the highway, borrow sources, waste areas, and all ground occupied by the Design-Builder within the project limits in connection with the work shall be cleaned of all rubbish, excess materials, temporary structures, and equipment; and all parts of the work shall be left in an acceptable condition.

The Design-Builder will not be directly compensated for the work of final cleaning up, as this work will be considered incidental to the work covered by the various contract items.

104-12 VALUE ENGINEERING PROPOSAL

This value engineering specification is to provide an incentive to the Design-Builder to initiate, develop, and present to the Department of Transportation for consideration, any cost reduction proposals conceived by him involving changes in the drawings, designs, specifications, or other requirements of the contract. This specification does not apply unless the proposal submitted is specifically identified by the Design-Builder as being presented for consideration as a Value Engineering Proposal. Submittals that propose material substitutions of permanent features such as changes from rigid to flexible or flexible to rigid pavements, concrete to steel or

steel to concrete bridges will not be considered acceptable Value Engineering Proposals. Depending on complexity of evaluation and implementation, Value Engineering Proposals that provide for total savings prior to distribution of less than the thousand dollars (\$10,000.00) will not generally be considered.

Value Engineering Proposals contemplated are those that would result in a net savings to the Department by providing a decrease in the total cost of construction or reduce the construction time without increasing the cost to construct the project. The effects the Proposal may have on the following items, but not limited to these items, will be considered by the Department when evaluating the proposal:

- | | |
|-------------------------|--------------------------|
| 1) Service Life | 6) Desired Aesthetics |
| 2) Safety | 7) Design |
| 3) Reliability | 8) Standardized Features |
| 4) Economy of Operation | 9) Environmental Impact |
| 5) Ease of Maintenance | |

The Department reserves the right to reject the Proposal or deduct from the savings identified in the Proposal to compensate for any adverse effects to these items which may result from implementation of the Proposal.

The Department reserves the right to reject at its discretion any Value Engineering Proposal submitted which would require additional right of way. Substitution of another design alternate, which is detailed in the design-build package, for the one on which the Design-Builder proposed, will not be allowed. Plan errors which are identified by the Design-Builder and which result in a cost reduction will not qualify for submittal as a Value Engineering Proposal. Pending execution of a formal supplemental agreement, implementing an approved Value Engineering Proposal, the Design-Builder shall remain obligated to perform in accordance with the terms of the existing contract. No time extension will be granted due to the time required to review a Value Engineering Proposal.

The Design-Builder is encouraged to include this specification in contracts with subcontractors. The Design-Builder shall encourage submissions of Value Engineering Proposals from subcontractors, however, it is not mandatory that the Design-Builder accept or transmit to the Department Value Engineering Proposals proposed by his subcontractors. The Design-Builder may choose any arrangement for the subcontractor value engineering payments, provided that these payments shall not reduce the Department's share of the savings resulting from the Value Engineering Proposal.

Should the Design-Builder desire a preliminary review of a possible Value Engineering Proposal, prior to expending considerable time and expense in full development, a copy of the preliminary proposal shall be submitted to the Resident Engineer and the Value Engineering Office. The submittal shall state Preliminary Value Engineering Proposal Review Request and must contain sufficient drawings; cost estimates and written information that can be clearly understood and interpreted. Also include the identity of any Private Engineering Firms proposed by the Design-Builder to prepare designs or revisions to designs. The Department will review the preliminary submittal only to the extent necessary to determine if it has possible merit as a Value Engineering Proposal. This review does not obligate the Department to approve the final proposal should a preliminary review indicate the proposal has possible merit. The Department

is under no obligation to consider any Value Engineering Proposal (Preliminary or Final) that is submitted.

A copy of the Final Value Engineering Proposal shall be submitted by the Design-Builder to the Resident Engineer and the Value Engineering Office. The proposal shall contain, as a minimum, the following:

- (1) A statement that the request for the modification is being made as a Value Engineering Proposal.
- (2) A description of the difference between the existing contract requirements and the proposed modifications, with the comparative advantages and disadvantages of each.
- (3) If applicable, a complete drawing of the details covering the proposed modifications and supporting design computations shall be included in the final submittal. The preparation of new designs or drawings shall be accomplished and sealed by a Professional Engineer registered in the State of North Carolina. Further, the Department may require a review, and possibly the redesign, be accomplished by the project's original designer, or an approved equal. The Department may contract with private engineering firms, when needed, for reviews requested by the Department. The contractor shall contract with the original project designer, or an approved equal, when required by the Department, for any design work needed to completely and accurately prepare contract drawings. The Department may waive the requirements to have the preparation of contract drawings accomplished by a Professional Engineer or the project's original design based on the extent, detail, and complexity of the design needed to implement the value engineering proposal.
- (4) An itemized list of the contract requirements that would be modified and a recommendation of how to make each modification.
- (5) A detailed estimate of the cost of performing the work under the proposed modification.
- (6) A statement of the time by which approval of the Value Engineering Proposal must be issued by the Department to obtain the total estimate cost reduction during the remainder of the contract, noting any effect on the contract completion or delivery schedule.

To facilitate the preparation of revisions to contract drawings, the contractor may purchase reproducible copies of drawings for his use through the Department's Value Engineering Office. The preparation of new design drawings by or for the Design-Builder shall be coordinated with appropriate Department Branch through the Value Engineering Office. The contractor shall provide, at no charge to the Department, one set of reproducible drawings of the approved design needed to implement the value engineering proposal.

The Engineer, as defined in Article 101-34 of the Standard Specifications, will be the sole judge of the acceptability of a Value Engineering Proposal requested in accordance with these provisions and of the estimated net savings resulting from the approval of all or any part of the Proposal. The Design-Builder has the right to withdraw, in whole or in part, any Value Engineering Proposal not accepted by the Department within the period to be specified in the Proposal per Item (6) of the preceding paragraph.

If a Value Engineering Proposal is approved, the necessary changes will be effected by Supplemental Agreement. Included as a part of the Supplemental Agreement will be provisions for price adjustment giving the Design-Builder 50 percent of the net savings to the project resulting from the modifications.

The Department reserves the right to include in the Supplemental Agreement any conditions it deems appropriate for consideration, approval, and implementation of the proposal. Acceptance of the Supplemental Agreement by the Design-Builder shall constitute acceptance of such conditions.

The final net savings to be distributed will be the difference in cost between the existing contract cost for the involved unit bid items and actual final cost occurring as a result of the modification. Only those unit bid items directly affected by the Supplemental Agreement will be considered in making the final determination of net savings. In determining the estimate net savings, the Department reserves the right to disregard the contract prices if, in the judgement of the Department, such prices do not represent a fair measure of the value of the work to be performed or to be deleted. Subsequent change documents affecting the modified unit bid items but not related to the Value Engineering Proposal will be excluded from such determination. The Department's review and administrative costs for value engineering proposals will be borne by the Department. The Design-Builder's costs for designs and/or revisions to designs and the preparation of design drawings will be borne by the Design-Builder. The costs to either party will not be considered in determining the net savings obtained by implementing the value engineering proposal. The Design-Builder's portion of the net savings shall constitute full compensation to him for effecting all changes pursuant to the agreement. The net savings will be prorated, 50 percent for the Design-Builder and 50 percent for the Department, for all accepted Value Engineering Proposals.

Upon execution of the Supplemental Agreement, the Department will thereafter have the right to use, duplicate or disclose in whole or in part any data necessary for utilization of the modification on other projects without obligation or compensation of any kind to the Design-Builder. Restrictions or conditions imposed by the Design-Builder for use of the proposal on other projects shall not be valid.

Except as may be otherwise precluded by this specification, the Design-Builder may submit a previously approved value engineering proposal on another project.

Unless and until a Supplemental Agreement is executed and issued by the Department, the Design-Builder shall remain obligated to perform the work in accordance with the terms of the existing contract.

Acceptance of the modification and its implementation will not modify the completion date of the contract unless specifically provided for in the Supplemental Agreement.

The Design-Builder shall not be entitled to additional compensation under Section 104 of the Standard Specifications for alterations in the plans or in the details of construction pursuant to the Value Engineering Proposal.

The Department will not be liable to the Design-Builder for failure to accept or act upon any Value Engineering Proposal submitted pursuant to this provision nor for any delays to the work attributable to any such proposal.

The Department reserves the right to negotiate desired changes with the Design-Builder under the provisions of the contract even though the changes are the result of a Value Engineering Proposal submitted on another contract. In this instance the savings will be prorated in accordance with the terms of the negotiated agreement.

SECTION 105
CONTROL OF WORK

105-1 AUTHORITY OF THE ENGINEER.

The Engineer will decide all questions which may arise as to the quality and acceptability of materials furnished and work performed and as to the rate of progress of the work; all questions which may arise as to the interpretation of the contract; and all questions as to the acceptable fulfillment of the contract on the part of the Design-Builder. His decision shall be final and he shall have executive authority to enforce and make effective such decisions and orders as the Design-Builder fails to carry out promptly.

The Engineer shall have the authority to issue any written order to the Design-Builder which he considers necessary to the prosecution of the work, and shall have executive authority to enforce such written orders as the Design-Builder fails to carry out promptly. Failure on the part of the Design-Builder to comply with any written order issued by the Engineer may be justification for disqualifying the Design-Builder from further bidding in accordance with Article 102-16.

105-2 PLANS AND WORKING DRAWINGS.

See Scope of Work:

105-3 CONFORMITY WITH PLANS AND SPECIFICATIONS.

All work performed and all materials furnished shall be in reasonably close conformity with the lines, grades, cross sections, dimensions, and material requirements, including tolerances, shown on the plans, or indicated in the specifications.

In the event the Engineer finds the materials or the finished product in which the materials are used not within reasonably close conformity with the plans and specifications but that reasonably acceptable work has been produced, he will then make a determination if the work is to be accepted and remain in place. If the Engineer determines that the work is to be accepted, he will have the authority to make such adjustment in contract price as he deems warranted based upon his engineering judgment and the final estimate will be paid accordingly.

In the event the Engineer finds the materials or the finished product in which the materials are used or the work performed are not in reasonably close conformity with the plans and specifications and have resulted in an inferior or unsatisfactory product, the work or materials shall be removed and replaced or otherwise corrected by the contractor at no cost to the Department.

The Design-Builder shall bear all the costs of providing the burden of proof that the nonconforming work is reasonable and adequately addresses the design purpose. The Design-Builder shall bear all risk for continuing with nonconforming work in question until it is accepted.

The Engineer may impose conditions for acceptance of the nonconforming work. The Design-Builder shall bear all costs for fulfilling the conditions.

The decisions whether the product satisfies the design purpose, whether the nonconforming work is reasonably acceptable and the conditions for acceptance are within the sole discretion of the Engineer.

105-4 COORDINATION OF PLANS, SPECIFICATIONS, SUPPLEMENTAL SPECIFICATIONS, AND SPECIAL PROVISIONS.

The Design-Build Package, the Plans, the Standard Specifications, and all supplementary documents are essential parts of the contract and a requirement occurring in one is as binding as though occurring in all. They are intended to be complementary and to describe and provide for a complete work.

In case of discrepancy or conflict, the order in which they govern shall be as follows:

- (A) Design-Build Package
- (B) Technical Proposal
- (C) Accepted Construction Plans
- (D) Standard Drawings
- (E) Standard Specifications

Where dimensions on the plans are given or can be computed from other given dimensions they shall govern over scaled dimensions.

The Design-Builder shall take no advantage of any error or omission in the plans, estimated quantities, or specifications. In the event the Design-Builder discovers an error or omission, he shall immediately notify the Engineer.

105-5 COOPERATION BY DESIGN-BUILDER.

The Design-Builder shall cooperate with the Engineer, his inspectors, and other contractors in every way possible, and shall give the work the constant attention necessary to facilitate the progress and satisfactory performance thereof. The Design-Builder shall notify the Engineer in writing at least 7 days prior to beginning work on the project. He shall notify the Engineer at least 1 day in advance when work is to be suspended and at least 2 days in advance when work is to be resumed.

The Design-Builder shall keep available on the project site at all times the contract assembly including special provisions, standard specifications, and plans.

105-6 SUPERVISION BY DESIGN-BUILDER.**(A) On Site Personnel:**

At all times that work is actually being performed the Design-Builder shall have present on the project one competent individual who has been authorized to act in a supervisory capacity over all work on the project including work subcontracted. The individual who has been so authorized shall be experienced in the type of work being performed and is to be fully capable of managing, directing, and coordinating the work; of reading and thoroughly understanding the contract; and of receiving and carrying out directions from the Engineer or his authorized representatives. He shall be an employee of the Design-Builder, unless otherwise approved by the Engineer.

(B) On Call Personnel:

At all times during the life of the project the Design-Builder shall provide one permanent employee who shall have the authority and capability for the overall responsibility of the project and who shall be personally available at the site of work within 24 hours notice. Such employee shall be fully authorized to conduct all business with the Subcontractors, to negotiate and execute all supplemental agreements, and to execute the orders or directions of the Engineer.

(C) Exceptions:

If the Design-Builder elects to have the employee described under (B) above constantly available in person on the project, then the presence of this employee will be considered as also meeting the requirements of (A) above. However, whenever such employee is absent from the project then an authorized individual meeting the requirements of (A) above shall be present on the project.

105-7 COOPERATION BETWEEN CONTRACTORS OR DESIGN-BUILDERS.

The Department reserves the right at any time to contract for and perform other or additional work on or near the work covered by the contract.

When separate or additional contracts are let within the limits of any one project, each Contractor or Design-Builder shall conduct his work so as not to interfere with or hinder the progress or completion of the work being performed by other Contractors or Design-Builders. Contractors or Design-Builders working within the limits of the same project shall cooperate with each other.

Each Contractor or Design-Builder shall conduct his operations in such a manner as to avoid damaging any work being performed by others or which has been completed by others.

The Department will under no circumstances be liable for any claim for additional compensation due to acts of one Contractor or Design-Builder holding up the work of another.

The Department will under no circumstances be liable for any damages experienced by one Contractor or Design-Builder as a result of the presence and operations of other Contractors or Design-Builders working within the limits of the same project.

105-8 COOPERATION WITH UTILITY OWNERS

Prior to the beginning of construction, the Department or Design-Builder will notify all utility owners known to have facilities affected by the construction of the project and will make arrangements for the necessary adjustments of all affected public or private utility facilities. The utility adjustments may be made either before or after the beginning of construction of the project. The adjustments will be made by the utility owner or his representative or by the Design-Builder when such adjustments are part of the work covered by his contract.

The Design-Builder shall use special care in working around and near all existing utilities that are encountered during construction, protecting them where necessary so that they will give uninterrupted service.

The Design-Builder shall cooperate with the utility owner, and/or the owner's representative in the adjustment or placement of utility facilities when such adjustment or placement is made necessary by the construction of the project or has been authorized by the Department.

In the event that utility services are interrupted by the Design-Builder, the Design-Builder shall promptly notify the owners and shall cooperate with the owners and/or the owner's representative in the restoration of service in the shortest time possible.

Existing fire hydrants shall be kept accessible to fire departments at all times.

The Design-Builder shall make his own determination as to the nature and extent of the utility facilities, including proposed adjustments, new facilities, or temporary work to be performed by the utility owner or his representative; and as to whether or not any utility work is planned by the owner in conjunction with the project construction. The Design-Builder shall consider all of the permanent and temporary utility facilities in their present or relocated positions. It will be the Design-Builder's responsibility to anticipate any additional costs to him resulting from such utility work and to reflect these costs in his bid for the various items in the contract.

Where changes to utility facilities are to be made solely for the convenience of the Design-Builder, it shall be the Design-Builder's responsibility to arrange for such changes and the Design-Builder shall bear all costs of such changes.

105-9 CONSTRUCTION STAKES, LINES, AND GRADES.

The Design-Builder shall be responsible for any surveying, construction staking and layout required in the performance of the work. He will be responsible for the accuracy of lines, slopes, grades and other engineering work which he provides under this contract. Unless otherwise specified in the Request for Proposal, no measurement or direct payment will be made for this work. The cost shall be considered as included in other contract items.

105-10 AUTHORITY AND DUTIES OF THE INSPECTOR.

Inspectors employed by the Department are authorized to inspect all work done and materials furnished. Such inspection may extend to all or any part of the work and to the preparation, fabrication, or manufacture of the materials to be used. The inspector is not authorized to alter or waive the provisions of the contract. The inspector is not authorized to issue instructions contrary to the plans and specifications, or to act as foreman for the Contractor; however, he has the authority to reject work or materials until any questions at issue can be referred to and decided by the Engineer. The inspector is not authorized to make any final acceptance of the work.

105-11 INSPECTION OF WORK.

All materials and each part or detail of the work shall be subject to inspection by the Engineer. The Design-Builder shall allow and provide a reasonable access to all parts of the work to the Engineer or his authorized representative. The Design-Builder shall also furnish such information and assistance as is required to make a complete and detailed inspection. Such access shall meet the approval of the Engineer.

The presence of the Engineer at the work site shall in no way lessen the Design-Builder's responsibility for conformity with the plans and specifications. Should the Engineer, prior to or during construction, fail to point out or reject materials or work that does not conform with plans and specifications, whether from lack of discovery or for any other reason, it shall in no way prevent later rejection or corrections to the unsatisfactory materials or work when discovered.

The Design-Builder shall have no claim for losses suffered due to any necessary removals or repairs resulting from the unsatisfactory work.

If the Engineer requests it, the Design-Builder, at any time before acceptance of the work, shall remove or uncover such portions of the finished work as may be directed. After examination, the Design-Builder shall restore said portions of the work to the standard required by the specifications. The Design-Builder shall keep cost records of the work performed and if the uncovered work is found to be acceptable, the Department will pay the Design-Builder on a force account basis in accordance with Article 109-3 for the cost of uncovering, or removing, and the replacing of the covering or making good of the parts removed; but should the work so exposed or examined prove unacceptable, the uncovering, or removing, and the replacing of the covering or making good of the parts removed, shall be at no cost to the Department.

When any other unit of government or political subdivision is to pay a portion of the cost of the work covered by the contract, its respective representatives shall have the right to inspect the work. When work is to be performed on the right of way of any railroad corporation or in proximity to other public utilities, the representatives of the railroad corporation and/or the public utilities shall have the right to inspect the work. Such inspection shall in no sense make any unit of government or political subdivision or any railroad corporation or public utility a party to the contract, and shall in no way interfere with the rights of either party thereunder.

105-12 UNAUTHORIZED WORK.

No work shall be performed without established lines and grades except as otherwise permitted by the Engineer. Work performed contrary to the instructions of the Engineer or contrary to any approvals granted by the Engineer will be considered as unauthorized and will not be paid for under the provisions of the contract. Work performed beyond the lines shown on the plans or as given, except as herein specified, or any extra work performed without authority will be considered as unauthorized and will not be paid for under the provisions of the contract. Any of the above work so performed may be ordered removed, replaced, or repaired at no cost to the Department.

Upon failure on the part of the Design-Builder to comply forthwith with any order of the Engineer made under the provisions of this article, the Engineer will have the authority to cause such unauthorized work to be removed and/or adjusted to conform to the provisions of the contract and to deduct the cost of removal and/or adjustment from any monies due or to become due the Design-Builder.

105-13 LIMITATIONS OF OPERATIONS.

At any time when, in the opinion of the Engineer, the Design-Builder has obstructed, closed, or is conducting operations on, a greater portion of the work than is necessary for the prosecution of the work so as to constitute a hazard to the general public or impair the function of the facility being constructed where traffic must be maintained, the Engineer may require the Design-Builder to finish the portions on which work is in progress before starting work on additional portions of the work.

105-14 NIGHT WORK.

Whenever the Design-Builder's operations are being conducted at night, the Design-Builder shall provide such artificial lighting as may be necessary to provide for safe and proper construction and to provide for adequate inspection of the work as described in Section 1412.

105-15 RESTRICTION OF LOAD LIMITS.

The Design-Builder shall comply with all legal load restrictions in hauling equipment and materials on roads under the jurisdiction of the Department.

The Department has the right to place load limit restrictions on the load a Design-Builder may haul on any road or bridge in the vicinity of his contract. The Design-Builder, prior to bidding on a project, will be responsible for making his own investigations to determine beforehand the possibility of load limit restrictions being placed on any of the highways he plans to use for hauling purposes. The Design-Builder shall not be entitled to an extension of time or to compensation for any costs, inconvenience, delay, or any other adversity to the Design-Builder as the result of any reduction by the Department in load limit, or as the result of a refusal by the Department to raise load limits as hereinafter provided or under any other conditions, and any such reduction in load limit or refusal to raise load limits shall not constitute a basis for a claim for additional compensation.

Wherever load limit restrictions below the statutory legal load limit have been posted on any roads and/or bridges on the project or within the vicinity of the project, the Department may remove the load limit restrictions from such roads and/or bridges upon written request from the Design-Builder; and the Design-Builder thereafter will be allowed to haul up to the statutory legal limits over such roads and/or bridges, provided the Design-Builder enters into an agreement with the Department providing for:

1. Maintenance by the Design-Builder of such roads in a condition satisfactory to the Engineer during the haul period.
2. Repair by the Design-Builder of all damages to such roads after haul is completed to place them in a condition as good as they were prior to removal of the load limits.
3. Furnishing bond by the Design-Builder in an amount determined by the Engineer for the roads. Furnishing a bond for the roads does not entitle the Design-Builder to exceed the posted load limits of any bridge.
4. Assumption by the Design-Builder of all costs of strengthening any bridges which may be necessary in order to safely haul loads up to statutory legal limits. The Department will, upon request by the Design-Builder, make a determination as to the method and extent of strengthening required for the bridges and will advise the Design-Builder as to the amount of work to be done or an estimate of the charges for the work if performed by Department forces. When Department forces perform the work, the Design-Builder shall reimburse the Department in the amount of the actual charges for said work. When Design-Builder's forces perform the work, it shall be done in accordance with plans approved by the engineer and under his inspection.
5. Indemnification of the Department against any and all claims from third persons arising out of or resulting from the hauling operation or the maintenance, or lack of maintenance, of haul roads. Haul roads shall be maintained not only for the Design-Builder's hauling operations, but also for the use of the public.

Equipment operated on proposed bridges shall comply with the following load restrictions.

Maximum axle load (lbs.).....	36,000
Maximum axle load on tandem axles (lbs.).....	30,000
Maximum gross load (lbs.).....	90,000

The Design-Builder shall keep the bridge floor clean to reduce impact forces and place approved temporary guides on the bridge floor to position the wheel loads as nearly as possible over the bridge girders. Only one earth moving vehicle shall be on a bridge at any time. Upon completion of hauling over each bridge, the Design-Builder shall clean the bridge floor, curbs and rails.

Regulations pertaining to size and weight will not apply to equipment used on the project provided the vehicles involved are not operated on pavement, completed base course, or structures.

105-16 FAILURE TO MAINTAIN THE PROJECT OR PERFORM EROSION CONTROL WORK.

Failure on the part of the Design-Builder to comply with the provisions of Article 104-10 or to perform erosion control work as directed will result in the Engineer notifying the Design-Builder to comply with these provisions. In the event that the Design-Builder fails to begin such remedial action or fails to begin erosion control work within 24 hours after receipt of such notice with adequate forces and equipment, the Engineer may proceed to have the work performed with other forces. No payment will be made to the Design-Builder for work performed by others. Any costs incurred by the Department for work performed by others as provided above in excess of the costs that would have been incurred had the work been performed by the Design-Builder will be deducted from monies due the Design-Builder on his contract.

105-17 INSPECTION AND ACCEPTANCE.

Upon apparent completion of the entire project, the Engineer will make an inspection of the project for final acceptance. If all construction provided for and contemplated by the contract is found to be satisfactorily completed, the project will be accepted. The acceptance of projects in there entirely will not be altered except as listed below:

1. When any continuous project is equal to or in excess of 5 miles in length, the Department will accept the project in 2 increments with the first increment equaling at least 50 percent of the total length of the project.
2. When it is considered to be in the best interest of the Department, other increments or parts of projects may be considered for acceptance.
3. When the contract contains an intermediate completion date requiring the completion of a portion of the work in its entirety, such portion of the work may be accepted if requested in writing by the Design-Builder.
4. Bridge decks and rails that have been constructed or rehabilitated at such time as they are open to public traffic.

5. Permanent sign panels, including hardware and retroreflective sheeting, that are required prior to the final acceptance of the project by the Traffic Control Plans or by the Engineer when the roadway where the signs are located is open to public traffic.

Acceptance of any increment or part of a project shall not operate to waive the assessment of all or any portion of liquidated damages assessable under the terms of the contract.

When the inspection discloses any work, in whole or in part, as being unsatisfactory or incomplete, the Engineer will advise the Design-Builder of such unsatisfactory or incomplete work, and the Design-Builder shall immediately correct, repair, or complete such work. The project will not be accepted and the Design-Builder shall be responsible for the maintenance of the project and maintenance of traffic until all of the recommendations made at the time of the inspection have been satisfactorily completed.

The Engineer will notify the Design-Builder in writing that the project has been accepted as soon as practicable after the completion of the project.

105-18 Substantial Completion

When the special provisions provide for a reduction in the rate of liquidated damages for the contract time or an intermediate contract time after the work is substantially complete, the work will be considered substantially complete when the following requirements are satisfied:

1. Through traffic has been placed along the project or along the work required by an intermediate contract time and the work is complete to the extent specified below, and all lanes and shoulders are open such that traffic can move unimpeded at the posted speed. Intersecting roads and service roads are complete to the extent that they provide the safe and convenient use of the facility by the public.
2. The final layers of pavement for all lanes and shoulders along the project or along the work required by an intermediate contract time are complete.
3. All signs are complete and accepted except for the signs on intersecting roadways.
4. All guardrails, drainage devices, ditches, excavation and embankment are complete.
5. Remaining work along the project consists of permanent pavement markings, permanent pavement markers or incidental construction that is away from the paved portion of the roadway.

Upon apparent substantial completion of the entire project or the work required by an intermediate contract time, the Engineer will make an inspection of the work. If the inspection discloses the entire project or the work required by an intermediate contract time is substantially complete; the Engineer will notify the Design-Builder in writing that the work is substantially complete. If the inspection discloses the entire project or the work required by an intermediate contract time is not substantially complete, the Engineer will notify the Design-Builder in writing of the work that is not substantially complete. The entire project or the work required by an intermediate contract time will not be considered substantially complete until all of the recommendations made at the time of the inspection have been satisfactorily completed.

SECTION 106

CONTROL OF MATERIAL

106-1 GENERAL REQUIREMENTS.

The materials used on the work shall meet all requirements of the contract and shall be subject to inspection, test, or rejection by the Engineer at any time. Materials used in the work shall be new or recycled as permitted by the Specifications.

It is the Departments intent to expand the use of recovered materials in its construction programs. The Design-Builder is encouraged to find innovative and alternative ways for beneficial use of recyclable materials that are currently a part of the solid waste stream and that contribute to problems of declining space in landfills.

The Design-Builder shall make his own determination of the various kinds and quantities of materials that are necessary for the acceptable performance and timely completion of the work. It will be the Design-Builder's responsibility to obtain materials which will meet the requirements of the contract. The Design-Builder shall be responsible for the acceptability of all materials used in the work and for the timely delivery of materials to the project so that adequate time will be available for the safe and proper performance of the work.

The Design-Builder shall provide access, means, and assistance in the verification of all testing equipment, scales, measures, and other devices operated by him in connection with the testing of the materials.

If the Design-Builder desires or is required to furnish materials from local deposits, other than those, if any, described in the contract he shall assume full responsibility for the sampling of the sources and the acceptability of the material in accordance with these specifications. He shall furnish without charge such preliminary samples as may be required; except that, if requested in writing, the Engineer may allow Department forces to take samples as requested by the Design-Builder. In the latter case, the Design-Builder shall reimburse the Department for the total expense of the sampling as determined by the Engineer. Tests will be made and reports rendered, but it is understood that such tests shall in no way be construed as a guarantee of acceptance of any material which may be delivered later for incorporation in the work. The Design-Builder shall assume full responsibility for the production of uniform and satisfactory materials from such local deposits, and shall indemnify and save harmless the Department from any and all claims for loss or damages resulting from the opening and operation thereof, or from the failure of the deposit after development to produce materials acceptable to the Engineer, in either quality or quantity.

106-2 SAMPLES, TESTS, AND CITED SPECIFICATIONS.

The Design-Builder shall perform Quality Control (QC), that may be used in the acceptance decision, at the frequencies described in the Minimum Sampling Guide. Quality Assurance (QA), verification and Independent Assurance (IA) will be performed by the Department. Laboratory testing performed by the Design-Builder shall be performed by an AASHTO Accredited facility and participate in the AMRL/CCRL proficiency testing program for the tests being performed. Technicians performing sampling and testing shall be qualified in accordance with the Department's training and certification requirements for the specific materials, or in accordance with AMRL/CCRL accreditation requirements.

Prior to beginning construction, the Design-Builder shall provide a "Table of Values" as described in Section 101-102 Definitions of Terms.

All tests will be made in accordance with the most recent standard or interim methods of the AASHTO in force on the date of advertisement. Should no AASHTO method of test exist for a material, the most recent standard or tentative method of ASTM or other methods adopted by the Department will be used.

All reference made to a specification published by AASHTO, ASTM, or any other organization other than the Department, which does not indicate the date of publication, will be understood to mean the specification current on the date of Request for Proposals for the project. When a more current specification is published during the life of the project, and when it is mutually agreed by the Design-Builder and the Engineer and such agreement is documented by a supplemental agreement, the Department may accept materials meeting the requirements of the latest publication.

106-3 DESIGN-BUILDER FURNISHED CERTIFICATION.

The Design-Builder shall maintain material certifications obtained from the producer, supplier, or an approved independent testing laboratory for the following types of materials, unless otherwise directed by the Engineer

1. Materials required to meet criteria documented by tests which are normally performed during the production process.
2. Materials which are required to meet specifications other than those published by AASHTO, ASTM, or the Division of Highways.
3. Materials produced at locations which are not within routine travel distance for Department representatives.
4. Materials required to meet criteria documented by tests involving special equipment not readily available to Department representatives.
5. Any other special material when so directed by the Engineer.

Material certifications of one of the following types shall be furnished for pre-tested materials. The specific type of material certification for each material shall be in accordance with the Department's Minimum Sampling Guide.

Type 1 Certified Mill Test Report:

A certified mill test report shall be a certified report of tests conducted by the manufacturer on samples taken from the same heat or lot number as the material actually shipped to the project. The report shall identify the heat or lot number.

Type 2 Typical Certified Mill Test Report:

A typical certified mill test report shall be a certified report of tests conducted by the manufacturer on samples taken from a lot which is typical of the material actually shipped to the project, but which may or may not be from the lot shipped.

Type 3 Manufacturer's Certification:

A manufacturer's certification shall be a certified statement that the material actually shipped to the project was manufactured by production processes which

are periodically and routinely inspected to assure conformance to specification requirements.

Type 4 Certified Test Reports:

A certified test report shall be a certified report of test conducted by an approved independent testing laboratory on samples taken from same heat or lot number as the material actually shipped to the project. The report shall identify the heat or lot number.

Type 5 Typical Certified Test Reports:

A certified test report shall be a certified report of tests conducted by an approved independent testing laboratory on samples taken from a lot which is typical of the material actually shipped to the project, but which may or may not be from the lot shipped.

Type 6 Supplier's Certification:

A supplier's certification is a signed statement by the supplier that the material described in the certification is of the specification grade required and that the supplier has on hand Type 1, Type 2, or Type 3 material certifications to cover the material which is included in the Type 6 supplier's certification.

Type 7 Design-Builder's Certification:

Design-Builder's certification is a signed statement by a contractor that the used material described in the certification meets the requirements of the current specifications to the best of contractor's knowledge and that the contractor had in his possession at the time of purchase a Type 1, 2 or 3 materials certification to cover the material which is included in the Type 7 contractor's certification.

Final Material Certificate:

The Design-Builder shall, upon completion of the project, certify that all certifications were received and the materials were found in compliance with the specification requirements and list all exceptions to the plans and specifications. This certification shall be in the following format:

“This is to certify that the results of the tests on Acceptance and QC/QA samples indicate that the materials incorporated in the construction work and the construction operations controlled by sampling and testing, were in conformity with the approved plans and specifications. Such results compare favorably with the results of the independent assurance sampling and testing. Exceptions to the plans and specifications are noted below:”

Upon final acceptance of the Project, the Design-Builder shall submit all certifications to the Engineer.

106-4 DELIVERY AND HANDLING OF MATERIALS.

All materials shall be handled carefully and in such manner as to preserve their quality and fitness for the work. Materials damaged during delivery or handling shall not be used without approval of the Engineer.

106-5 STORAGE OF MATERIALS.

Materials shall be stored so as to insure the preservation of their quality and fitness for the work. Stored materials, which may have been approved before storage, shall be subject to inspection at any time, and shall meet the requirements of the specifications at the time they are put into use. Stored materials shall be so located as to facilitate their inspection. Subject to the approval of the Engineer, that portion of the right of way not required for public travel may be used for storage purposes and for the Design-Builder's plant and equipment, but any additional space required therefor shall be provided by the Design-Builder at no expense to the Department. All storage sites located within the right of way shall be restored to their original condition by the Design-Builder at no expense to the Department, except where the materials stored are or are to become the property of the Department.

106-6 INSPECTION AT SOURCE.

The Engineer may undertake the inspection of materials at the source of supply. This inspection will be performed by Department personnel or private organizations retained by the Department. Where approved by the Engineer, the results of tests performed by private laboratories or producer's or manufacturer's laboratories may be used in determining compliance of a material or product with the contract.

The Department assumes no obligation to inspect materials at the source of supply and such inspection will be undertaken only upon condition that:

1. The cooperation and assistance of the Design-Builder and the producer with whom he has contracted for materials is assured.
2. The representative of the Engineer will have full entry at all times to such parts of the plant as may concern the manufacture or production of the materials.
3. Laboratory facilities shall be provided when required by the Engineer.

Where the Department agrees to inspect or test materials during their production or at the source of supply, the Design-Builder shall bear the cost of testing performed on materials ordered by him but not incorporated into the project. For items normally pretested by the Department, the Design-Builder shall provide a minimum of 30 days notice prior to the beginning of production of the items for this project along with final approved shop drawings.

The Department reserves the right to retest all materials which have been tested and accepted at the source of supply after the same have been delivered, and to reject all materials which, when retested, do not meet the requirements of the specifications.

106-7 SCALES AND PUBLIC WEIGHMASTER.

In the event material is to be paid for on a ton basis, the Contractor shall furnish platform scales or other weighing devices which have been certified by the N. C. Department of Agriculture. If the platform scales or other weighing devices are located outside of North Carolina, they shall have been certified by the Department of Agriculture within the particular State. The scales may be constructed and operated to provide automatic weighing, recording, and printing of tickets for the load being weighed.

All scales shall be operated by a public weighmaster licensed in accordance with Chapter 81A of the General Statutes of North Carolina. A certified weight certificate shall be issued by a North Carolina public weighmaster for each load. The certificate shall be in the form of a ticket furnished by the Contractor and shall contain the following information:

1. Division of Highways project number.
2. Date.
3. Time issued, if for bituminous plant mix or portland cement stabilized base course mixed in a central plant.
4. Type of material.
5. Gross weight.
6. Tare weight.
7. Net weight of material.
8. Quarry or plant location.
9. Division of Highways' Job Mix Formula Number, if ticket is for asphalt plant mix.
10. Division of Highways' Asphalt Plant Certification Number, if ticket is for asphalt plant mix.
11. Truck number.
12. Contractor's name.
13. Public weighmaster's stamp or number.
14. Public weighmaster's signature in ink or initials in ink.

When certified weighing devices other than platform scales are to be used, the gross weight and tare weight will not be required.

The Engineer may direct the Contractor to re-weigh the contents of any truck load that is to be delivered to the work on approved platform scales at no cost to the Department.

When tractor and trailer units are to be utilized in hauling material to be weighed, the platform scales shall be of sufficient length so as to accommodate the entire unit or the tractor shall be disconnected and the trailer and its contents weighed as a separate unit.

106-8 DEPARTMENT FURNISHED MATERIAL.

The Design-Builder shall furnish all materials necessary to complete the work, except those materials specified in the Design-Build Package to be furnished by the Department. Payment at the contract price for the item which includes the use of Department furnished material will be full compensation for all costs of handling and placing such materials after they are delivered or made available to the Design-Builder.

The Design-Builder will be held responsible for all material furnished him, and deductions will be made from any money due him to make good any shortage and deficiencies from any cause whatsoever and for any damage which may occur after Department furnished material has been made available.

106-9 DEFECTIVE MATERIAL

All materials which are not in reasonably close conformity to the requirements of the specifications shall be considered as defective and such materials, whether in place or not, shall be rejected and are to be removed from the site of the work unless otherwise permitted by the Engineer in accordance with Article 105-3. No rejected material, the defects of which may have been substantially corrected, may be used until approval has been given by the Engineer.

106-10 DENSITY DETERMINATION BY NUCLEAR METHODS.

The Engineer may, at his option, utilize nuclear methods as described in Article 520-10 and 610-11C to determine the density of selected pavement materials. The use of nuclear methods will include the establishment of the required density through the use of control strips constructed from materials actually being used on the project, and the determination of the density being obtained in test sections located throughout the project.

SECTION 107
LEGAL RELATIONS AND RESPONSIBILITY
TO PUBLIC

107-1 LAWS TO BE OBSERVED.

The Design-Builder shall keep himself fully informed of all Federal and State laws, all local laws, ordinances, and regulations, and all orders and decrees of bodies or tribunals having any jurisdiction or authority which may in any manner affect those engaged or employed in the work, or which in any way affect the conduct of the work. He shall at all times observe and comply with all such laws, ordinances, regulations, orders, and decrees; and shall indemnify and hold harmless the Board of Transportation and the Department of Transportation and their agents and employees from any claim or liability arising from or based on the violation of any such law, ordinance, regulation, order, or decree, by the Design-Builder or by his agents and employees.

107-2 ASSIGNMENT OF CLAIMS VOID.

In accordance with G.S. 143-3.3, the Department will not recognize any assignment of claims by any Design-Builder.

107-3 PERMITS AND LICENSES.

The Design-Builder shall procure all permits and licenses except as otherwise specified; pay all charges, fees, and taxes; and give all notices necessary and incident to the due and lawful prosecution of the work.

107-4 PATENTED DEVICES, MATERIALS, AND PROCESSES.

If the Design-Builder employs any design, device, material, or process covered by letters of patent or copyright, he shall provide for such use by suitable legal agreement with the patentee or owner. The Design-Builder and his surety shall indemnify and save harmless the Department from any and all claims for infringement by reason of the use of such patented design, device, material, process, trademark, or copyright, and shall indemnify and save harmless the Department from any costs, expenses, and damages which it may be obligated to pay at any time during the prosecution or after the completion of the work by reason of any infringement.

107-5 ENCROACHMENT ON RIGHT OF WAY.

Any individual, firm, or corporation wishing to encroach on highway right of way shall secure a written permit from the Department. The Design-Builder is not authorized to allow any individual, firm, or corporation to perform any work within the limits of the project unless such work has been authorized in writing by the Engineer.

When so directed by the Engineer, the Design-Builder shall make any repairs necessary due to such encroachments and such work will be paid for as extra work.

107-6 FEDERAL PARTICIPATION.

When the United States Government pays all or any portion of the cost of the work, the Federal laws authorizing such participation and the rules and regulations made pursuant to such laws shall be observed by the Design-Builder. The work will be subject to the inspection of the representative of such Federal agencies as are created for the administration of these laws. The Design-Builder shall have no right to make the Federal Government a party to any court action

solely by reason of its participation in the cost of the work or by reason of its inspection of the work.

107-7 SANITARY PROVISIONS.

The Design-Builder shall provide and maintain in a neat, sanitary condition such accommodations for the use of his employees as may be necessary to comply with the requirements of the State and local Board of Health, or of other bodies or tribunals having jurisdiction.

107-8 PUBLIC CONVENIENCE AND SAFETY.

The Design-Builder shall at all times so conduct his work as to insure the least possible obstruction to traffic. The safety and convenience of the general public and the residents along the highway, and the protection of persons and property, shall be provided for by the Design-Builder as specified in Section 150.

107-9 COORDINATION WITH RAILWAY.

All work to be performed by the Design-Builder on railway right of way shall be done in a manner satisfactory to the railway company, and shall be performed at such times and in such manner as not to unnecessarily interfere with the movement of traffic upon the track of the railway company. The Design-Builder shall use all care and precautions in order to avoid accidents, damage, or unnecessary delays or interference with the railway company's traffic or other property. The Design-Builder shall carry such railroad protective insurance and public liability and property damage insurance as may be stipulated in the special provisions.

When the Design-Builder is required by the plans or special provisions to transport materials or equipment across the tracks of any railway or to perform work on railway right of way, the Design-Builder will obtain any necessary written authority from the railway company for the establishment of a railway crossing or for the performance of work on railway right of way. The Design-Builder will be required to bear the cost of any watchman service or flagging protection necessary due to such operations, as the railway company will be reimbursed directly by the Design-Builder for the cost of such work.

In case the Design-Builder elects or finds it necessary to transport materials or equipment across the tracks of any railway at any point where a crossing is not required by the plans or special provisions, or at any point other than an existing public crossing, he shall obtain specific written authority from the railway company for the establishment of a private railway crossing and shall bear all costs in connection with such crossing, including installation, drainage, maintenance, any necessary insurance, watchman service, flagging protection, and removal of such private railway crossing.

107-10 WORK IN, OVER, OR ADJACENT TO NAVIGABLE WATERS.

All work in or over navigable waters shall be in accordance with conditions contained in the permit obtained by the Department from the authority granting the permit. These conditions will be included in the project special provisions. The work shall be performed in such manner so as not to interfere with navigation of the waterway unless approval therefor is obtained from the authority granting the permit.

The Design-Builder shall prepare drawings necessary to obtain any addendums which may be required for his operations which are not included in the Department's permit. He shall coordinate their submission with the Engineer.

107-11 USE OF EXPLOSIVES.

When the use of explosives is necessary for the prosecution of the work, the Design-Builder shall exercise the utmost care not to endanger life or property. The Design-Builder shall be responsible for any and all damage or injury to persons or property resulting from the use of explosives. Such responsibility shall include, but shall in no way be limited to all damages arising from all forms of trespass to adjacent property as a result of blasting by the Design-Builder. Provided that in cases of damage or interruption to underground water supply or veins to adjacent landowners, the Design-Builder shall not be held responsible where the Design-Builder has used reasonable care and has taken reasonable precautions to prevent such damage.

All explosives shall be stored in a secure manner, in compliance with all laws, and all such storage places shall be marked clearly "DANGEROUS EXPLOSIVES."

The Design-Builder shall notify each public utility company having facilities in close proximity to the site of the work of his intention to use explosives. This notice shall be given sufficiently in advance to enable the utility companies to take whatever steps they may consider necessary to protect their property from injury. The Design-Builder shall also give the Engineer, all occupants of adjacent property, and all other Contractors working in or near the project notice of his intention to use explosives. Motorists shall be notified in accordance with Article 1101-10.

The Design-Builder shall submit a blasting plan to the Engineer within 24 hours after each shot. The blasting plan shall contain the full details of the drilling and blasting patterns unless otherwise approved by the Engineer, and shall contain the following information: (1) station limits of shot, (2) plan of drill hole pattern, blast hole spacing, blast hole diameters and free face, (3) initiation sequence of blastholes including delay timer and delay system, (4) manufacturers data sheet for all explosives, primers, and initiators employed, (5) loading diagram showing type and amount of explosives, primers, initiators, and location and depth of stemming. The blasting plan submitted is for quality control and record keeping purposes. Review by the Engineer shall not relieve the Design-Builder of his responsibilities as provided in Article 107-12.

107-12 PROTECTION AND RESTORATION OF PROPERTY.

The Design-Builder shall be responsible for the protection from his activities of all public and private property on and adjacent to the work and shall use every reasonable precaution necessary to prevent damage or injury thereto. He shall use suitable precautions to prevent damage to pipes, conduits, and other underground structures, and to poles, wires, cables, and other overhead structures.

The Design-Builder shall protect carefully from disturbance or damage all land monuments and property markers until the Engineer has witnessed or otherwise referenced their location and shall not remove them until directed.

The Design-Builder shall be responsible for the removal, preservation, and resetting of all mail boxes disturbed by the construction operations. The mail boxes and their supports, when reset, shall be left in as good a condition as they were before removal. The Design-Builder will

not be required to furnish new material except as required to repair damage resulting from construction operations.

The Design-Builder will be held responsible for all damage or injury to property of any character resulting from any act, omission, negligence, or misconduct in the prosecution of the work. When any direct or indirect damage or injury is done to public or private property by or on account of any act, omission, negligence, or misconduct in the execution of the work, he shall either restore at his own expense such property to a condition similar or equal to that existing before such damage or injury was done, or shall make good such damage or injury in a manner acceptable to the owner of the damaged property and to the Department. In case of failure on the part of the Design-Builder to restore such property or make good such damage or injury the Department may at the Design-Builder's expense repair, rebuild, or otherwise restore such property in such manner as the Engineer may consider necessary.

107-13 CONTROL OF EROSION, SILTATION, AND POLLUTION.

(A) General:

The Design-Builder shall take whatever measures are necessary to minimize soil erosion and siltation, water pollution, and air pollution caused by his operations. The Design-Builder shall also comply with the applicable regulations of all legally constituted authorities relating to pollution prevention and control. The Design-Builder shall keep himself fully informed of all such regulations which in any way affect the conduct of the work, and shall at all times observe and comply with all such regulations. In the event of conflict between such regulations and the requirements of the specifications, the more restrictive requirements shall apply.

The Engineer will limit the area over which clearing and grubbing, excavation, borrow, and embankment operations are performed whenever the Design-Builder's operations do not make effective use of construction practices and temporary measures which will minimize erosion, or whenever construction operations have not been coordinated to effectively minimize erosion, or whenever permanent erosion control features are not being completed as soon as permitted by construction operations.

Following completion of any construction phase or operation, on any graded slope area greater than one acre, the Design-Build Team shall provide ground cover sufficient to restrain erosion within 21 calendar days or within a time period specified by the *Sedimentation and Pollution Control Act*. The ground cover shall be either temporary or permanent and the type specified in the contract.

(B) Erosion and Siltation Control:

The Design-Builder shall exercise every reasonable precaution throughout the life of the project to prevent the eroding of soil and the silting of rivers, streams, lakes, reservoirs, other water impoundments, ground surfaces, or other property.

Prior to suspension of operations on the project or any portion thereof, the Design-Builder shall take all necessary measures to protect the construction area, including but not limited to borrow sources, soil type base course sources, and waste areas, from erosion during the period of suspension.

Excavated materials shall not be deposited, nor shall earth dikes or other temporary earth structures be constructed, in rivers, streams, or impoundments. As an exception to the above, confined earth materials will be permitted when approved in writing by the Engineer.

(C) Coordination of Erosion Control Operations:

Temporary and permanent erosion control measures shall be provided as shown on the plans or as directed by the Engineer. All permanent erosion control work shall be incorporated into the project at the earliest practicable time. Temporary erosion control measures shall be coordinated with permanent erosion control measures and all other work on the project to assure economical, effective, and continuous erosion control throughout the construction and post construction period and to minimize siltation of rivers, streams, lakes, reservoirs, other water impoundments, ground surfaces, or other property.

Temporary erosion control measures shall include but not be limited to the use of temporary berms, dikes, dams, drainage ditches, silt basins, silt ditches, slope drains, structures, vegetation, mulches, mats, netting, gravel, or any other methods or devices that are necessary. Temporary erosion control measures may include work outside the right of way or construction limits where such work is necessary as a result of construction such as borrow operations, haul roads, plant sites, equipment storage sites, and disposal of waste or debris. The Design-Builder shall be liable for all damages to public or private property caused by silting or slides originating in waste areas furnished by the Design-Builder.

Materials for temporary erosion control measures shall have been approved by the Engineer before being used or shall be as directed by the Engineer.

Erosion control measures installed by the Design-Builder shall be acceptably maintained by the Design-Builder.

(D) Water and Air Pollution:

The Design-Builder shall exercise every reasonable precaution throughout the life of the project to prevent pollution of rivers, streams, and water impoundments. Pollutants such as chemicals, fuels, lubricants, bitumens, raw sewage, and other harmful waste shall not be discharged into or alongside of rivers, streams, or impoundments, or into natural or manmade channels leading thereto.

The Design-Builder shall comply with all State or local air pollution regulations throughout the life of the project.

(E) Dust Control:

The Design-Builder shall control dust throughout the life of the project within the project area and at all other areas affected by the construction of the project, including, but not specifically limited to, unpaved secondary roads, haul roads, access roads, disposal sites, borrow and material sources, and production sites. Dust control shall not be considered effective where the amount of dust creates a potential or actual unsafe condition, public nuisance, or condition endangering the value, utility, or appearance of any property.

The Design-Builder will not be directly compensated for any dust control measures necessary, as this work will be considered incidental to the work covered by the various contract items.

(F) Application of Specifications:

The provisions of this article shall apply to all construction operations. Further references and detailed requirements concerning erosion, siltation, and pollution prevention and control are given in other sections of the specifications as supplements to the general requirements of this article.

(G) Sanctions:

In the event that temporary erosion and pollution control measures become necessary due to the Design-Builder's negligence, carelessness, or failure to incorporate permanent erosion control measures into the project at the earliest practicable time, such measures shall be performed by the Design-Builder as directed by the Engineer at no cost to the Department. If the Design-Builder fails to perform such measures as directed, the Engineer may have the work performed in accordance with Article 105-16.

Failure of the Design-Builder to fulfill any of the requirements of this article may result in the Engineer ordering the stopping of construction operations in accordance with Article 108-7 until such failure has been corrected. Such suspension of operations will not justify an extension of contract time.

Failure on the part of the Design-Builder to perform the necessary measures to control erosion, siltation, and pollution will result in the Engineer notifying the Design-Builder to take such measures. In the event that the Design-Builder fails to perform such measures within 24 hours after receipt of such notice with adequate forces and equipment, the Engineer may suspend the work as provided above, or may proceed to have such measures performed with other forces and equipment, or both. No payment will be made to the Design-Builder for the performance of this work and the cost of such work so performed will be deducted from monies due the Design-Builder on his contract.

107-14 PROTECTION OF PUBLIC LANDS.

In the execution of any work within or adjacent to any State or National forest, park, or other public lands, the Design-Builder shall comply with all regulations of all authorities having jurisdiction over such forest, park, or lands, governing the protection of public lands and the carrying out of work within public lands, and shall observe all sanitary laws and regulations with respect to the performance of work in public lands. He shall keep the areas in an orderly condition, dispose of all refuse, and obtain permits for the construction and maintenance of all construction camps, stores, warehouses, residences, latrines, cesspools, septic tanks, and other structures in accordance with the requirements of the appropriate authorities.

The Design-Builder shall take all reasonable precaution to prevent and suppress forest fires and shall require his employees and subcontractors, both independently and at the request of forest officials, to do all reasonable within their power to prevent and suppress and to assist in preventing and suppressing forest fires and to make every possible effort to notify a forest official at the earliest possible moment of the location and extent of any fire seen by them.

The Design-Builder shall obtain any construction permits, which may be required for his operations, which are not a part of the project, in accordance with the requirements of the regulations of the appropriate authorities.

107-15 RESPONSIBILITY FOR DAMAGE CLAIMS.

The Design-Builder shall indemnify and save harmless the Board of Transportation and its members and the Department of Transportation and its officers, agents, and employees from all suits, actions, or claims of any character brought for any injury or damages received or sustained by any person, persons, or property by reason of any act of the Design-Builder, Subcontractor, its agents or employees, in the performance of the contract. The Design-Builder's liability to save harmless and indemnify shall include, but not by way of limitation, the following: (1) damages or claims for the failure of the Design-Builder to safeguard the work; (2) damages or claims by reason of the failure of the Design-Builder to erect adequate barricades and post adequate warnings to the public of such barricades; (3) any damage or claims caused through the Design-Builder's use of defective materials or by the performance of defective work; (4) any claims by reason of the Design-Builder's infringement of patent, trademark, or copyright; (5) any amounts paid by the Department by reason of the Design-Builder's failure to comply with or for violations of laws, ordinances, orders, or decrees; (6) any damages or claims caused by blasting operations of the Design-Builder with or without proof of negligence on the part of the Design-Builder; (7) damages or claims caused by the failure of the Design-Builder to protect private or public property pursuant to Article 107-12, including damages to public and private property caused by silting and slides from waste areas furnished by the Design-Builder, without proof of negligence; (8) damages caused by the failure of the Design-Builder to control erosion in accordance with the plans and specifications.

In addition to any remedy authorized by law, the Department shall have a right to retain from moneys due the Design-Builder as the Department considers necessary until final disposition has been made of the following suits or claims: (1) For all claims against the Department involving claims or damages which are the Design-Builder's responsibility under Section 107 of the specifications. The Design-Builder and the Surety shall remain responsible until such suits or claims against the Department have been settled and until the Department has been indemnified and saved harmless. (2) In case of claims by the third parties against the Design-Builder involving tort liability for which the Department might be held liable for as a taking of property, or as a tort before the Industrial Commission. However, moneys due the Design-Builder will not be retained provided the Design-Builder produces satisfactory evidence to the Department that he is adequately protected from such tort liability by public liability and property damage insurance. In all other cases involving claims or suits by third parties against the Design-Builder, amounts due the Design-Builder will not be withheld provided that the consent of the Surety is furnished and the Surety guarantees payment of any amounts for which the Design-Builder may be determined to be legally liable for. (3) In cases of damage to property of the Department, such amounts necessary to pay for such damage.

In cases where claims are made or suits filed against employees, agents, or officers of the Department of Transportation or members of the Board of Transportation, the Department of Transportation may retain from moneys due the Design-Builder sufficient to indemnify such employee, agent, or officer of the Department of Transportation or member of the Board of Transportation for any amounts which they may be held liable for but for which the Design-Builder is responsible under the provisions of Section 107 of these specifications. In the event that there is not sufficient money retained or the final estimate is paid, the Department of Transportation may collect from the Design-Builder or its Surety amounts sufficient to

indemnify such employee, agent, or officer of the Department of Transportation or member of the Board of Transportation for such damages incurred.

107-16 LIABILITY INSURANCE.

When required by the special provisions the Design-Builder shall carry insurance of the kinds and in the amounts specified therein in addition to any other forms of insurance or bonds required under the terms of the contract, or any other insurance carried by the Design-Builder.

107-17 OPENING SECTIONS OF PROJECT TO TRAFFIC.

If it is determined by the Engineer that the Design-Builder will not complete the work by the completion date, intermediate completion date, or intermediate completion time, the Engineer may notify the Design-Builder in writing that upon expiration of contract time or intermediate contract time the project or any portion thereof will be open to traffic. On such sections, which are opened, the Design-Builder shall conduct the remainder of his operations to cause the least obstruction to traffic. The Design-Builder shall not be relieved of his liability or responsibility, shall not receive any additional compensation due to the added cost of the work, nor shall he receive any extension of the completion date, intermediate completion date, or intermediate completion time, by reason of such openings.

107-18 DESIGN-BUILDER'S RESPONSIBILITY FOR WORK.

Until final acceptance of the work by the Engineer, as evidenced in writing, the Design-Builder shall have the charge and care thereof and shall take every precaution against injury or damage to any part thereof by the action of the elements, or from any other cause, whether arising from the execution or from the nonexecution of the work. The Design-Builder shall rebuild, repair, restore, and make good all injuries or damages to any portion of the work occasioned by any of the above causes before final acceptance and shall bear the expense thereof, except as provided in other sections of the specifications. The Department will reimburse the Design-Builder for the repair of the work due to actions of the elements of such exceptional nature as to be legally classified as Acts of God.

In case of suspension of work from any cause whatever, the Design-Builder shall be responsible for all materials, and shall properly store them, if necessary, and shall provide suitable drainage of the roadway and erect necessary temporary structures at no cost to the Department.

107-19 FURNISHING RIGHT OF WAY.

The Department will be responsible for the securing of all necessary rights of way in advance of construction.

107-20 PERSONAL LIABILITY OF PUBLIC OFFICIALS.

Employees, agents, officers, and members of the Board of Transportation or the Department of Transportation shall not be held personally liable for any damages connected with the work, it being specifically understood in all such matters that they act solely as agents and representatives of the Board of Transportation or the Department of Transportation.

107-21 WAIVER OF LEGAL RIGHTS BY THE DEPARTMENT.

Upon completion of the work, the Department will expeditiously make an inspection and notify the Design-Builder of acceptance. Such final acceptance and processing of the final estimate, however, shall not preclude or stop the Department from correcting any measurement, estimate, or certificate made before or after completion of the work, nor shall the Department be precluded or stopped from recovering from the Design-Builder or his Surety, or both, such overpayment as it may sustain, or by failure on the part of the Design-Builder to fulfill his obligations under the contract. A waiver on the part of the Department of any breach of any part of the contract shall not be held to be a waiver of any other or subsequent breach.

The Design-Builder, without prejudice to the terms of the contract, shall be liable to the Department for latent defects, fraud, or such gross mistakes as may amount to fraud, or as regards the Department's rights under any warranty or guaranty.

107-22 SAFETY AND ACCIDENT PROTECTION.

The Design-Builder shall comply with all applicable Federal, State, and local laws, ordinances, and regulations governing safety, health, and sanitation, and shall provide all safeguards, safety devices, and protective equipment, and shall take any other needed actions, on his own responsibility that are reasonably necessary to protect the life and health of employees on the job and the safety of the public, and to protect property in connection with the performance of the work covered by the contract.

107-23 WAGES AND CONDITIONS OF EMPLOYMENT.

The Design-Builder's attention is directed to the provisions and requirements of any and all public statutes, which regulate hours, or conditions of employment on public work. Such provisions and requirements that are appropriate, in accordance with the intent of the particular law, act, or statute, will be applicable to all work performed by the Design-Builder with his own organization and with the assistance of workmen under his immediate superintendence, and to all work performed by subcontract. It will be the responsibility of the Design-Builder to ascertain the appropriate application of such provisions and requirements to the work.

In addition to the general requirements of the various regulations referred to above, certain additional regulations and restrictions may be imposed that are peculiar to the particular work under the contract. In such cases, these regulations and restrictions will be included in the special provisions for the particular project involved.

For projects that are financed wholly or in part with Federal funds, the minimum wage rates to be paid to all mechanics and laborers employed on the project will be determined by the U.S. Secretary of Labor. A schedule of such wage rates will be inserted in the Request for Proposals for such projects. The Design-Builder shall provide at the job site at no cost to the Department a weatherproof bulletin board covered with glass or rigid transparent plastic and shall display thereon at all times legible copies of such schedule of wage rates and of the wage rate information poster that will be furnished to him. The bulletin board shall be located in a conspicuous place easily accessible to all employees.

In the event that changes should occur in any of the regulations referred to in this article, or in any application thereof to the work under contract, no additional compensation will be allowed the Design-Builder as a result of such changes.

107-24 LIABILITY TO THIRD PARTIES.

It is not intended by any of the provisions of any part of these specifications to make the public or any member thereof a third party beneficiary hereunder, or to authorize anyone who is not a party to a contract entered into pursuant to these specifications to maintain a suit for personal injury or property damage otherwise than as authorized and provided by law.

107-25 RIGHT OF THE DESIGN-BUILDER TO FILE VERIFIED CLAIM.

If the Design-Builder fails to receive such settlement as he claims to be entitled to under the terms and provisions of the contract, the Design-Builder may submit a written and verified claim for such amounts he deems himself or his subcontractor(s) entitled to under the terms and provisions of the contract provided he has complied with the applicable provisions of the contract including, but not limited to, giving written notice of intent to file a claim, keeping and submission of cost records, and the initial submission of a written claim within the specified time period. The claim shall be submitted to the State Highway Administrator within 60 days from the time the Design-Builder receives the final estimate as defined by Article 101-38 and shall be submitted in accordance with G.S. 136-29.

107-26 HAZARDOUS, CONTAMINATED, AND/OR TOXIC MATERIAL.

When the Design-Builder's operations encounter or expose any abnormal condition which may indicate the presence of a hazardous, contaminated, and/or toxic material, such operations shall be discontinued in the vicinity of the abnormal condition and the Engineer shall be notified immediately. Upon notification by the Design-Builder, the Engineer will investigate the work and, if necessary, suspend the work in accordance with Article 108-7. The presence of barrels; old or abandoned underground storage tanks; and discolored earth, metal, wood, etc.; visible fumes; abnormal odors; excessively hot earth; smoke; or anything else which appears abnormal may be indicators of hazardous, contaminated, and/or toxic materials and shall be treated with extraordinary caution as they are evidence of abnormal conditions.

The Design-Builder's operations shall not resume until so directed by the Engineer.

Disposition of the hazardous, contaminated, and/or toxic material will be made in accordance with the requirements and regulations of the Department of Human Resources and the Department of Environment, Health & Natural Resources. Where the Design-Builder performs work necessary to dispose of hazardous, contaminated, and/or toxic material, payment will be made at the unit prices for pay items included in the contract which are applicable to such work or, where the contract does not include such pay items, payment will be made as provided in Article 104-7 for extra work. Where the contract does not include pay items for the work necessary to dispose of hazardous, contaminated, and/or toxic material, the Engineer may have the work performed by others.

SECTION 108**PROSECUTION AND PROGRESS****108-1 GENERAL.**

It is the intent of these specifications that the Design-Builder shall commence work on the date of availability shown in the Request for Proposals or as soon thereafter as practicable, but not before the contract has been executed by both the Design-Builder and the Department. The Design-Builder shall not begin work prior to the date of availability without written approval of the Engineer. If such approval is given and the Design-Builder does begin work prior to the date of availability the Department will assume no responsibility for any delays caused prior to the date of availability by any reason whatsoever, and such delays, if any, will not constitute a valid reason for extending the completion date.

It is further the intent of these specifications that the Design-Builder shall pursue the work diligently with workmen in sufficient numbers, abilities, and supervision, and with equipment, materials, and methods of construction as may be required to complete the work described in the contract, or as may be amended, by the completion date.

108-2 PROJECT SCHEDULE.

This section is replaced by the Project Special Provision entitled " Project Schedule" contained elsewhere in this Design-Build Package.

108-3 PREDESIGN CONFERENCE / PRECONSTRUCTION CONFERENCE.

The selected Design-Builder shall meet with the Engineer for a predesign conference concerning the design phase of the work. This conference shall be held prior to the commencement of work, as it is determined according to Article 108-1, and will be scheduled by the Engineer. At the predesign conference, the Design-Builder shall furnish authorized signature forms and a list of any proposed subcontractors and major material suppliers associated with the design of the project.

A preconstruction conference shall be held at least 10 working days before construction activity begins. This second conference, concerning the construction phase, shall also be scheduled by the Engineer. The Design-Builder shall give the Engineer a minimum of 45 days notice before he plans to begin construction activities. This will allow the Engineer time for any environmental agency representatives involved in the permitting process, as well as any other pertinent entities, to be scheduled to attend the preconstruction conference. If the Design-Builder is responsible for utilities in accordance with Article 105-8, he shall be responsible for coordinating with the Engineer in scheduling their attendance and for notifying them. The Design-Builder shall also be responsible for coordinating with the Engineer in scheduling the attendance of subcontractors and others deemed appropriate, and for notifying them.

At the preconstruction conference, a list of any proposed subcontractors and major material suppliers associated with the construction of the project will be submitted.

If the contract has a DBE requirement, the Design-Builder shall submit copies of completed and signed DBE subcontracts, purchase orders, or invoices to the Department.

The Design-Builder shall submit a traffic control plan in accordance with Article 1101-5. The Design-Builder shall designate an employee who is competent and experienced in traffic control

to implement and monitor the traffic control plan. The qualifications of the designated employee must be satisfactory to the Engineer.

The Design-Builder shall submit a safety plan and designate an employee as Safety Supervisor.

Both plans shall be submitted at the preconstruction conference and must be satisfactory to the Engineer. Should the design plan include activities that would place personnel on the work site, traffic control and safety plans for those activities would be submitted at the predesign conference.

During the preconstruction conference, the Engineer will designate a Department employee or employees who will be responsible to see that the traffic control plans and any alterations thereto are implemented and monitored to the end that traffic is carried through the work in an effective manner. If approved by the Engineer, the Design-Builder may designate one employee to be responsible for both the traffic control and safety plans. The Design-Builder shall not designate its superintendent as the responsible person for either the traffic control plan or the safety plan, unless approved by the Engineer.

If the project requires that Design-Builder or State personnel work from falsework, within shoring, or in any other hazardous area the Design-Builder shall submit, as part of the Design-Builder's safety plan, specific measures it will use to ensure worker safety.

The Design-Builder shall also submit a program for erosion control and pollution prevention on all projects involving clearing and grubbing, earthwork, structural work, or other construction, when such work is likely to create erosion or pollution problems.

If the Design-Builder fails to provide the required submissions, the Engineer may order the preconstruction conference suspended until such time as they are furnished. Work shall not begin until the preconstruction conference has been concluded and the safety plan has been approved, unless authorized by the Engineer. The Design-Builder shall not be entitled to additional compensation or an extension of contract time resulting from any delays due to such a suspension.

The Design-Builder shall designate a qualified employee as Quality Control Manager. The Quality Control Manager shall be responsible for the implementing and monitoring of the quality control requirements of the project.

108-4 CONSTRUCTION CONFERENCES.

After work on the project has begun, construction conferences are to be held no less than once per month. The construction conferences are to be scheduled at times, which are mutually agreeable to both the Design-Builder and the Department. It shall be the Design-Builder's responsibility to attend and record the proceedings of these conferences.

108-5 CHARACTER OF WORKMEN, METHODS, AND EQUIPMENT.

The Design-Builder shall at all times employ sufficient labor and equipment for prosecuting the several classes of work to full completion in the manner and time required by these specifications.

“The Design-Builder cannot recruit Department employees for employment. Additionally, Department employees who elect to become employed by a Design-Builder may not perform any

function on a project, which they have been involved in during employment with the Department without written consent of the State. Any person employed by the Design-Builder and assigned to a project who has previously been involved in the project as a Department employee shall be, at the written direction of the Engineer, removed from the project. An exception to these terms may be granted when recommended by the Secretary and approved by the Board of Transportation.

Failure of the Design-Builder to comply may be justification for disqualifying the Design-Builder from further bidding in accordance with the provisions of Article 102-16 and shall be grounds for termination of this contract.

No person shall be employed by the Design-Builder or by any Subcontractor who has been determined by the Engineer to have engaged in fraudulent activities in connection with any work for the Department of Transportation.

Any person employed by the Design-Builder or by any Subcontractor who, in the opinion of the Engineer, does not perform his work in a proper and skillful manner or is disrespectful, intemperate, or disorderly or who has been determined by the Engineer to have engaged in fraudulent activities in connection with any work for the Department of Transportation shall be, at the written request of the Engineer, removed forthwith by the Design-Builder or Subcontractor employing such person, and shall not be employed again in any portion of the work without the approval of the Engineer.

Should the Design-Builder fail to remove such person or persons as required above, the Engineer may suspend the work in accordance with the provisions of Article 108-7 until such orders are complied with.

All equipment, which is proposed to be used on the work, is to be of sufficient size and in such mechanical condition as to meet the requirements of the work and to produce a satisfactory quality of work. Equipment used on any portion of the project shall be such that no injury to the roadway, adjacent property, or other highways will result from its use. The Engineer may order in writing the removal and replacement of any unsatisfactory equipment.

When the methods and equipment to be used by the Design-Builder in accomplishing the construction are not prescribed in the contract, the Design-Builder is free to use any methods or equipment that he demonstrates to the satisfaction of the Engineer will accomplish the contract work in conformity with the requirements of the contract.

When the contract specifies that the construction be performed by the use of certain methods and equipment, such methods and equipment shall be used unless others are authorized by the Engineer. If the Design-Builder desires to use a method or type of equipment other than those specified in the contract, he may request authority from the Engineer to do so. The request shall be in writing and shall include a full description of the methods and equipment proposed to be used and an explanation of the reasons for desiring to make the change. If approval is given it will be on the condition that the Design-Builder will be fully responsible for producing construction work in conformity with contract requirements. If, after trial use of the substituted methods or equipment, the Engineer determines that the work produced does not meet contract requirements, the Design-Builder shall discontinue the use of the substitute method or equipment and shall complete the remaining construction with the specified methods and equipment. The Design-Builder shall remove the unsatisfactory work and replace it with work of specified

quality, or take such other corrective action as the Engineer may direct. No change will be made in basis of payment for the construction items involved nor in the completion date as a result of authorizing a change in methods or equipment under these provisions.

108-6 SUBLETTING OF CONTRACT.

The Design-Builder shall not sublet, sell, transfer, assign, or otherwise dispose of the contract or any portion thereof; or of his right, title, or interest therein; without written consent of the Engineer. In case such consent is given, the sublet work shall be performed by the Subcontractor unless otherwise approved in writing by the Engineer. Failure of the Design-Builder to comply with these provisions will be just cause for the work to be considered unauthorized in accordance with Article 105-12. A firm which has been disqualified due to its failure to maintain satisfactory progress under the provisions of Article 108-8 will not be approved as a subcontractor until the firm demonstrates the ability to perform the work in a satisfactory manner. When directed by the Engineer, the Design-Builder shall submit a certified copy of the actual subcontract agreement executed between the Design-Builder and Subcontractor prior to written consent being issued by the Engineer. In case such consent is given, the Design-Builder will be permitted to sublet a portion thereof, but shall perform with his own organization, work amounting to not less than 30 percent of the total original contract amount, except:

1. Any items sublet to Disadvantaged Business Enterprise (DBE), Minority Business (MB) or Women's Business (WB), up to the value of the contract DBE, MB or WB goal, will be deducted from the total original contract amount before computing the amount of work required to be performed by the Design-Builder with his own organization.

Extra work performed in accordance with Article 104-7 will not be considered in the computation of work required to be performed by the Design-Builder.

An assignment by operations of law or assignment for the benefit of creditors, or the bankruptcy of the Design-Builder, shall not vest any right in this contract in the Trustee in bankruptcy, the Design-Builder's creditors, or the agent of the creditors.

A Subcontractor shall not sublet, sell, transfer, assign, or otherwise dispose of his contract with a Design-Builder or any portion thereof; or of his right, title, or interest therein; without written consent of the Engineer. When directed by the Engineer, the Design-Builder shall submit a certified copy of the actual subcontract agreement executed between the Subcontractor and the Second Tier Subcontractor. In the event of an assignment by operations of law or the bankruptcy of the Subcontractor, the Design-Builder shall have the right, power, and authority, in its discretion, without violating the contract or releasing the Surety, to terminate the subcontract. An assignment by operations of law or assignment for the benefit of creditors or the bankruptcy of the Subcontractor shall not vest any right in this contract in the Trustee in bankruptcy, nor the Subcontractor's creditors or agents of the creditors.

Neither the Design-Builder, nor any Subcontractor, shall enter into any written or oral equipment lease or rental agreement, materials purchase agreement, and/or labor agreement which circumvents the provisions of this article.

If the Design-Builder or a Subcontractor enters into a lease or rental agreement for equipment based upon payment for a unit of work, such agreement will be considered subletting of the contract unless the lease or rental agreement is with a commercial equipment company, manufacturer, and/or commercial leasing agency and such firm has been approved by the

Engineer. An equipment lease or rental agreement, which is based upon unit prices per unit of time, will not be considered subletting of the contract.

The approval of any subcontract will not release the Design-Builder of his liability under the contract and bonds, nor will the Subcontractor or the second tier Subcontractor have any claim against the Department of Transportation by reason of the approval of the subcontract. The State Highway Administrator will review and consider Subcontractor claims for additional time or compensation provided such claims are submitted by the contractor in accordance with Article 107-25 and General Statute 136-29.

Failure of the Design-Builder to comply with any of the provisions of this article may be justification for disqualifying the Design-Builder from further bidding in accordance with the provisions of Article 102-16.

108-7 TEMPORARY SUSPENSION OF THE WORK.

The Engineer will have the authority to suspend the work wholly or in part by written order for such periods, as he may deem necessary for any of the following reasons:

1. Conditions considered unfavorable for the suitable prosecution of the work, or
2. The Design-Builder's failure to correct conditions unsafe for workmen or the general public, or
3. The Design-Builder has not carried out orders given to him by the Engineer, or
4. The Design-Builder's failure to perform any provisions of the contract.

No extension of the completion date will be allowed for the above suspensions except as may be provided for in Article 108-10.

108-8 FAILURE TO MAINTAIN SATISFACTORY PROGRESS.

The Engineer will check the Design-Builder's progress at the time each partial pay request is received. The Design-Builder's progress may be considered as unsatisfactory if, according to the CPM of Record, the projected finish date for all work exceeds the scheduled finish date by greater than 10%.

When the Design-Builder's progress is found to be unsatisfactory as described above, the Engineer may make written demand of the Design-Builder to state in writing the reason for the unsatisfactory progress and produce such supporting data as the Engineer may require or the Design-Builder may desire to submit. The Engineer will consider the justifications submitted by the Design-Builder and extensions of the completion date that have or may be allowed in accordance with Article 108-10(B).

When the Design-Builder cannot satisfactorily justify the unsatisfactory progress the Engineer may invoke one or more of the following sanctions:

1. Withhold anticipated liquidated damages from amounts currently due or which become due.
2. Remove the Design-Builder and all firms prequalified under the Design-Builder's Prequalification Number from the Department's list of qualified bidders.

When any of the above sanctions have been invoked, they shall remain in effect until rescinded by the Engineer.

108-9 DEFAULT OF CONTRACT.**(A) Declaration of Default:**

The Department shall have the right to declare a default of the contract for breach by the Design-Builder of any material term or condition of the contract or specifications. Material breach by the Design-Builder shall include, but specifically shall not be limited to failure to begin work under the contract within the time specified; failure to provide workmen, equipment, or materials adequate to perform the work in conformity with the plans and specifications by the completion date; unsatisfactory performance of the work; refusal or failure to replace defective work; failure to maintain satisfactory work progress; failure to comply with equal employment opportunity contract requirements; insolvency or bankruptcy, or any act of insolvency or bankruptcy; failure to satisfy any final judgment within 10 days after entry thereof; and making an assignment for benefit of creditors.

(B) Sanctions:

In the event of a breach of the contract by the Design-Builder, the Department shall have the right, power, and authority, in its sole discretion, without violating the contract or releasing the surety: to assume full control of the prosecution of the contract in the place and stead of the Design-Builder in directing Design-Builder's agents, employees, and Subcontractors in the performance of the work and in utilizing all materials, tools, machinery, equipment, and structures located on the project; to perform the work or any part thereof with Department personnel and equipment or to utilize any or all materials and equipment located on the project that are suitable and acceptable; to relet the work upon such terms and conditions as the Department shall deem appropriate; to employ any other methods that it may determine are required for completion of the contract in an acceptable manner; and to withhold any sums due the Design-Builder under the contract without penalty or interest until the work is completed and accepted by the Department.

(C) Notice:

Before invoking any of the sanctions provided for herein, the Department, acting through the Engineer, will give the Design-Builder at least 7 days written notice with a copy to the Surety, which will set forth the breach of contract involved and the sanctions to be imposed. The Department, in its discretion, may grant the Design-Builder time in excess of 7 days within which to comply with the contract terms and specifications, and the time allowed will be set forth in writing. If the Department determines during such period that the Design-Builder is not proceeding satisfactorily to compliance, it may impose the sanctions after 24 hours notice to the Design-Builder. If the Department determines that the Design-Builder is not in compliance at the end of the time allowed, it may immediately impose any of the sanctions set forth herein and will advise the Design-Builder, in writing, with a copy to the Surety of the sanctions imposed.

(D) Payment:

After declaration of default has been made final, the Design-Builder will be entitled to receive payment for work satisfactorily completed or portions of work satisfactorily completed, less any sums that may be due the Department from the Design-Builder but in no event shall payment exceed the contract unit or lump sum price for such work. The Department, at its election, may retain the sum due the Design-Builder, or any portion thereof, without interest or penalty, until the contract work is completed; or it may make payment to the Design-Builder

upon declaration of default for work satisfactorily completed to the date that notice of default is received by the Design-Builder. The Design-Builder may be required by the Engineer, however, to carry to a stage of completion satisfactory to the Engineer any work in progress, the value of which otherwise would be lost by immediate cessation of work. Payment for such work will be made upon the basis hereinafter set out.

In the event that the Design-Builder's employees, equipment, or materials are used in prosecution of the work, or any part thereof, after default is declared, payment to the Design-Builder may be by contract unit or lump sum prices for the work performed, or, if the Engineer determines that such prices do not represent the value of the work performed, payment for the type of work or services performed will be made on a force account basis, as set forth in Article 109-3, less any sums that may be due the Department; but in no event shall payment exceed the contract unit or lump sum price for such work or services. Determination of the method of payment shall be in the sole discretion of the Engineer, and he will advise the Design-Builder, in writing, of his determination with reference to the specific type of work or service to be performed.

If all costs and expenses incurred by the Department arising out of the breach and imposition of sanctions, together with the total cost to the Department of securing the performance of the work set forth in the contract, exceed the sum that would have been payable under the contract, the Design-Builder and the Surety shall be liable to the Department for such excess and shall pay such amount to the Department.

(E) Authority of Engineer:

The Engineer will exercise the powers and discretion vested in him by the specifications and other contract conditions in carrying out the terms of this article. He will have full power and authority to carry out any orders, directives, or resolutions issued by the Department in connection with a declaration of default. In the event that the Department fails to specify the sanctions to be imposed, the notice to be given, or the method of completing the work, the Engineer, may, in his discretion, impose such sanctions, give such notice, and select such methods of completing the work, as are authorized by this article; and such actions shall have the same effect and validity as if taken pursuant to an express order, directive, or resolution of the Department.

(F) Obligation of Design-Builder and Surety:

No term or terms of this article and no action taken pursuant hereto by the Department of Transportation, its agents, or employees, will be construed to release or discharge the Design-Builder or the Surety upon the obligation set forth in the contract bonds, and the Design-Builder and the Surety shall remain bound thereon unto the Department until the work set forth in the contract has been completed and accepted by the Department and all obligations of the Design-Builder and the Surety arising under the contract and contract bond have been discharged.

(G) Provision Not Exclusive:

The provisions shall be in addition to, and not in place of, any other provisions relating to default, breach of contract, and sanctions to be imposed in connection therewith appearing in the contract.

108-10 CONTRACT TIME; INTERMEDIATE CONTRACT TIME.**(A) General:**

The contract time will be as defined in Article 101-24. No extensions to the completion date will be authorized except as allowed by this article. No modifications in the date of availability will be made for any reason whatsoever.

Intermediate contract time, as defined in Articles 101-47 and 101-48, will be that as allowed in the special provisions to complete a part, portion, or phase of the total work covered in the contract. Intermediate completion dates and intermediate completion times set forth in the special provisions may be extended on the same basis as completion dates and as described in this article.

When the liquidated damages stipulated in the project special provisions are to be on an hourly basis, extensions as described in this article will be considered on an hourly basis.

(B) Completion Date, Intermediate Completion Date, and Intermediate Completion Time Extensions:

No extension of the completion date, intermediate completion date, or intermediate completion time will be allowed for any reason except as provided for below:

1. If supplemental agreements covering the performance of extra work include provisions for an extension of the completion date, intermediate completion date, or intermediate completion time, and the final dollar value of the extra work exceeds the estimated dollar value, the number of days or the number of hours by which the completion date, intermediate completion date, or intermediate completion time was extended will be increased by the percentage which the final dollar value exceeds the estimated value.
2. If the Design-Builder's current controlling operation(s) are delayed by circumstances originating from work required under the contract and beyond his control and without his fault or negligence, he may, at any time prior to the final payment make a written request to the Engineer for an extension of the completion date, intermediate completion date, or intermediate completion time. This request shall include: (a) the circumstances resulting in the alleged delay and documentation of said circumstances as may be required by the Engineer, (b) the controlling operation(s) alleged to have been delayed, (c) the calendar dates or calendar dates and times on which the controlling operation(s) were delayed and (d) the number of calendar days or hours by which he is requesting the completion date, intermediate completion date, or intermediate completion time to be extended. If the Engineer determines that the controlling operation(s) were delayed because of circumstances beyond the control of and without the fault or negligence of the Design-Builder, and that the Design-Builder has pursued the work in accordance with Article 108-1, he will extend the completion date, intermediate completion date, or intermediate completion time unless otherwise precluded by other provisions of the contract. No extension of the completion date, intermediate completion date, or intermediate completion time will be allowed for delays caused by restrictions, limitations or provisions contained in the contract.

3. If changes in the work from that originally contemplated in the Design-Build Package are ordered by the Engineer and these changes result in additional work and/or extra work, the Engineer will allow an extension in the completion date, intermediate completion date, or intermediate completion time as he may deem warranted by such changes. It is, however, the Design-Builder's responsibility to show just cause for an extension in the completion date, intermediate completion date, or intermediate completion time due to the aforesaid conditions.

Submit all requests for extensions of Contract time in writing. Only delays to activities which affect the Contract completion date will be considered for an extension of contract time. No time extensions will be granted until a delay occurs which impacts the project's critical path, consumes all available float, and extends the work beyond the contract completion date. Include in the request a written narrative describing the events, which would require an extension of contract time.

Any extension to the Contract completion date will be based on the number of calendar days the Contract completion date is impacted as determined by the Engineer's analysis.

The Design-Builder's plea that insufficient contract time (days), intermediate contract time (days), or intermediate contract time (hours) was specified in the contract will not be considered as a valid reason for an extension in the completion date, intermediate completion date, or intermediate completion time.

108-11 LIQUIDATED DAMAGES.

It is mutually recognized that time is an essential element of the contract, and that delay in completing the work will result in damages due to public inconvenience, obstruction to traffic, interference with business, and the increasing of engineering and administrative costs to the Department. It is therefore agreed that in view of the difficulty of making a precise determination of such damages, a sum of money in the amount stipulated in the special provisions will be charged against the Design-Builder for each calendar day, each hour, or portion thereof that the work, or any portion of the work as described in the special provisions, remains uncompleted after the expiration of the completion date, intermediate completion date, or intermediate completion time shown in the special provisions, not as a penalty but as liquidated damages.

Should the Design-Builder or, in case of default, the Surety fail to complete the work or any portion of the work by any of the applicable completion dates, intermediate completion dates, or intermediate completion times shown in the special provisions, a deduction of the amount stipulated in the special provisions as liquidated damages will be made for each and every calendar day, for each and every hour, or portion thereof that the work or any portion of the work remains uncompleted after the expiration of any completion date, intermediate completion date, or intermediate completion time applicable to the uncompleted work. This amount will be deducted from any money due the Design-Builder or his Surety under the contract, and the Design-Builder and his Surety will be liable for any liquidated damages in excess of the amount due.

In the event that the special provisions establish one or more intermediate completion dates and/or one or more intermediate completion times in addition to the completion date, each of the liquidated damages stipulated will be considered to be cumulative to any other liquidated damages stipulated.

In case of default of the contract and the completion of the work by the Department, the Design-Builder and his Surety will be liable for the liquidated damages under the contract, but no liquidated damages will be chargeable for any delay in the final completion of the work by the Department due to any action, negligence, omission, or delay of the Department.

In any suit for the collection of or involving the assessment of liquidated damages, the reasonableness of the amount stipulated in the contract will be presumed. The liquidated damages referred to herein are intended to be and are cumulative, and will be in addition to every other remedy now or hereafter enforceable at law, in equity, by statute, or under the contract.

Permitting the Design-Builder to continue and finish the work or any part thereof after the expiration of the completion date, intermediate completion date, or intermediate completion time shall in no way operate as a waiver on the part of the Department of any of its rights under this contract.

108-12 EXTENSION OF CONTRACT TIME AND APPORTIONMENT OF LIQUIDATED DAMAGES.

It is the intent of Articles 108-10 and 108-11 of these specifications that when a contract is not completed by the completion date, intermediate completion date, or intermediate completion time the Design-Builder shall be entitled to an extension of the completion date, intermediate completion date, or intermediate completion time and apportionment and remittance of liquidated damages to the extent that the failure to complete was due to the conditions set forth in Article 108-10. The Design-Builder, however, shall be entitled to an extension of the completion date, intermediate completion date, or intermediate completion time, or an apportionment and remittance of liquidated damages only to the extent and in the proportion that such delays were caused by the conditions set forth in Article 108-10, and it is understood that any extension granted shall not operate to waive any liquidated damages or any claim which the Department has or may have against the Design-Builder by reason of failure of the Design-Builder to complete the said contract by the completion date, intermediate completion date, or intermediate completion time specified therein or as revised by authorized extensions.

108-13 TERMINATION OF CONTRACT.

The Board may terminate the contract in accordance with the following provisions:

1. Consideration will be given to termination of the contract if any of the following circumstances exist:
 - a. If it is impossible for the Design-Builder to obtain critical materials for completion of the contract within a practical time limit, or
 - b. If it is impossible for the Design-Builder to complete the work in accordance with the contract by reason of unanticipated conditions at the site, including slides and unstable subsoil, without a major change in the design of the project and the Design-Builder will be unduly delayed in completing the project by reason of such unanticipated conditions and changes in design, or

- c. If the Design-Builder is prevented from proceeding with the contract as a direct result of an Executive Order of the President with respect to the prosecution of war or in the interest of national defense, or
 - d. If the Design-Builder is prevented from proceeding with the work required by the contract as a direct result of a restraining order, or other court order, or by reason of a permit requirement, and the Design-Builder will be unduly delayed in completing the project by reason of such order or requirement, or
 - e. If the Design-Builder is prevented from proceeding with the work due to the unavailability of the site.
2. The Design-Builder shall determine that the circumstances in item 1 exist and are beyond his control, and shall notify the Department in writing of his determination and include adequate documentation of these circumstances along with such notification.
3. The Contract will be terminated under this article if:
 - a. Request by Design-Builder:
 - i. The Board concurs in the determination by the Design-Builder of the circumstances or makes an independent determination that such circumstances hereinabove indicated exist, and
 - ii. The Board determines that such circumstances are beyond the control of the Design-Builder, and the Design-Builder was not at fault in creating the circumstances, and
 - iii. The Board determines that a termination of the contract is in the best public interest, or
 - b. Authority of the Board:

The Board determines that a termination of the contract is in the best public interest.
4. The Design-Builder will be notified in writing by the State Highway Administrator of the action of the Board.
5. After a contract is terminated in accordance with this termination provision, the following provisions shall be applicable:
 - a. When the contract is terminated before completion of all items of work in the contract, payment will be made for the actual number of acceptably completed items of work or acceptably completed portions thereof at the contract unit or lump sum prices. When the contract is terminated before completion of all items of work in the contract and items of work are partially completed or not begun, payment will be made in accordance with Article 104-6.
 - b. Upon request from the Design-Builder, materials meeting the requirements of the contract which were to have been incorporated into the work or were to remain the property of the Department but are not used in the work will be paid for in accordance with Article 109-6.
 - c. No claim for loss of anticipated profits will be considered and no payment will be made for loss of anticipated profits.

- d. Termination of a contract shall not relieve the Design-Builder of his responsibilities for any completed portion of the work nor shall it relieve his Surety, of its obligation for and concerning any just claims arising out of the work performed.

108-14 TERMINATION OF CONTRACTOR'S RESPONSIBILITY.

After the project has been completed and accepted, as provided for in Article 105-17, the Design-Builder's responsibility will cease except as provided in Article 107-21 and as set forth in his contract bonds.

SECTION 109

MEASUREMENT AND PAYMENT

109-1 MEASUREMENT OF QUANTITIES.

All work completed under the contract will be measured by the Engineer according to United States standard measures unless otherwise stated in the contract.

The method of measurement and computations used in the determination of quantities of material furnished and of work performed under the contract will be those methods generally recognized as conforming to accepted engineering practice.

The terms "gage" and "thickness", when used in connection with the measurement of plates, sheets, and steel wire, shall be applied as follows:

Uncoated Steel Sheets and Light Plates.....	United States Standard Gage
Galvanized Sheets.....	AASHTO M218 or M167
Aluminum Sheets.....	AASHTO M196 or M197
Steel Wire.....	AASHTO M32

The term ton will mean short ton consisting of 2,000 pounds avoirdupois.

Cement will be measured by the barrel unless otherwise indicated elsewhere in the Specifications. The term barrel will mean 376 pounds of cement.

Trucks used to haul material being paid for by weight will be either weighed empty prior to each loading or weighed empty on a daily basis. When trucks are weighed empty on a daily basis, each truck shall be weighed prior to hauling its first load of the day and shall bear a legible identification mark.

Where aggregates that are to be paid for by weight have been stockpiled after being produced, measurement for purposes of payment will be made after the aggregates have been loaded on trucks for direct delivery to the project.

When a complete structure or structural unit, as may be indicated by the unit "lump sum" or "each", is specified as the unit of measurement, the unit will be construed to include all necessary fittings and accessories.

When standard manufactured items are specified, and these items are identified by gage, unit weight, section dimensions, and/or other dimensions, such identification will be considered to be nominal weights or dimensions. Unless more stringently controlled by tolerances in cited specifications, manufacturing tolerances established by the industries involved will be accepted.

109-2 SCOPE OF PAYMENT.

The Design-Builder shall receive and accept compensation provided for in the contract as full payment for furnishing all materials and performing all work under the contract in a complete and acceptable manner and for all risk, loss, damage, or expense of whatever character arising out of the nature of the work or the prosecution thereof, subject to the provisions of Article 107-21. Payment to the Design-Builder will be made only for the work completed, certified and accepted in accordance with the terms of the contract.

If the "Basis of Payment" or "Compensation" clause in the specifications relating to any unit price or lump sum price in the bid schedule requires that the said unit price or lump sum price

cover and be considered compensation for certain work or material essential to the item, this same work or material will not also be measured or paid for under any other pay item which may appear elsewhere in the specifications.

109-3 FORCE ACCOUNT WORK (9-12-05)

DESIGN

The actual costs for labor will be paid.

CONSTRUCTION

All force account work shall be performed as directed by the Engineer including the numbers and types of equipment, the numbers and classifications of labor and foremen, and material requirements.

All work to be paid for on a force account basis shall be paid for in the following manner:

- A) Labor.** For all authorized labor and foremen in direct charge of the specific operations, the Design-Build Team will receive the rate of base (actual) wages (or scale) actually being paid by the Contractor for each hour that the labor and foremen are actually engaged in the specific force account work.

In addition to reimbursement for each hour that the labor and foremen are actually engaged in the specific force account work, the Design-Build Team may receive compensation for travel time to and from the project if and only if the labor and foremen needed are outside a 75 mile radius as included in Section 109-3(2B). The base location will be established and approved by the Engineer prior to performing the specific force account work. If the approved labor and foremen travel to another project upon completion of the specific force account work, payment for travel time may not exceed the travel time that would have been required to return to the point of origin in accordance with Section 109-3(2B). When travel time is approved by the Engineer, it shall be included in the total hours approved and worked for that specific week. The Engineer will approve the mode of travel.

Prior to beginning the specific force account work, the Design-Build Team will submit in writing for the Engineer's approval a list of all wage rates applicable to the work. Approval will not be granted where these wage rates are not actually representative of wages being paid elsewhere on the project for comparable classes of labor performing similar work.

Payment for overtime will be allowed when approved by the Engineer prior to performing the specific force account work. Overtime for labor and foremen will be paid based on the company's policy for overtime payment. Verification of such payment will be tracked by submission of weekly payrolls as required on federal projects and as requested on all other projects. Failure to submit payrolls as required or requested shall act as a bar to the Design-Build Team for payment of overtime for labor and foremen. If the labor or foremen is employed partly on specific force account work and partly on other work, the amount of overtime to be reimbursed will be prorated based upon the number of hours worked on the specific force account work during the payroll period.

An additive amount equal to the Design-Build Team's actual labor burden rate, up to a maximum of 60 percent, will be paid to the Design-Build Team for all base (actual) wages paid to labor and foremen for the specific force account work. No additive will be provided for overtime payments. The labor burden rate(s) will include costs associated with the employee's actual base wages benefits, including FICA, unemployment contributions, Social Security and Medicare taxes and company fringe benefits. Company fringe benefits are the actual costs paid to, or on behalf of, workmen by reason of health and welfare benefits, pension fund benefits, or other benefits, when such amounts are required by prevailing wage laws generally applicable to the classes of labor employed on the work. The Design-Build Team's actual labor burden rate(s) will shall be submitted to and approved by the Engineer prior to beginning the work. When the Design-Build Team cannot verify actual labor burden rate(s), an, an amount equal to 35 % percent of the total base (actual) wage paid for labor and foremen will be added to the total base wages paid to the Design-Build Team. These percentage additives will be full compensation for overhead, benefits, contingencies, and all other costs associated with labor for the specific force account work.

- (B) Subsistence and Travel Allowances.** The Design-Build Team may receive payment for actual costs paid to, or on behalf of, labor and foremen by reason of subsistence and travel allowances under certain circumstances. When the Design-Build Team is required to mobilize a crew for specific operations, the Engineer may approve reimbursement of subsistence, including meals and overnight lodging, if the specific force account work is determined to be outside of the scope of the original contract and the distance from the Design-Build Team's base location to the project is more than 75 miles. Should the Design-Build Team utilize forces currently working at the location of the specific force account work, the Engineer may approve the payment of subsistence, including meals and overnight lodging, if the work is determined to be outside of the scope of the original contract, the forces currently working at the location have routinely stayed overnight during the life of the project, and the distance from the Design-Build Team's base location to the project is more than 75 miles. The Engineer will approve the mode of travel.

Payment will be made to the Design-Build Team for subsistence, including meals and overnight lodging, paid in accordance with the Design-Build Team's usual policy for authorized labor and foremen in direct charge of the specific operations.

Subsistence will be limited to the lesser of actual amount paid or the current maximum in-state rate for State employees. Verification of such costs paid to, or on behalf of, labor and foremen will shall be submitted to the Engineer. If the labor or foremen are partly employed on specific force account work and partly on other work, the amount of subsistence to be reimbursed will be prorated based upon the number of hours worked on the specific force account work during the payroll period.

- (C) Materials.** For materials authorized and accepted by the Engineer and used, the Design-Build Team will receive the actual cost of such materials, including sales tax and transportation charges paid by him (exclusive of equipment rentals as hereinafter set forth), to which costs 15% percent will be added. The Design-Build Team will shall furnish records to the Engineer to verify the quantities of materials used in the specific

force account work, prices of the materials, sales tax, and costs of transportation for the materials.

If materials used in the specific force account work are not specifically purchased for such work but are taken from the Design-Build Team's stock, the Design-Build Team will shall furnish an affidavit certifying that such materials were taken from his stock, the quantity was actually used in the specific force account work, and the price and transportation cost claimed represent the actual cost to the Design-Build Team.

- (D) Equipment.** For all equipment authorized by the Engineer to be used on the specific force account work the Design-Build Team will receive rental payment. Hourly rental rates paid for equipment in use, which is Design-Build Team owned or rented from another Design-Build Team, will not exceed 1/176th of the monthly rate listed in the *Rental Rate Blue Book for Construction Equipment* that is current at the time the specific force account work is performed.

In determining the hourly rate, the regional adjustment factor and the rate adjustment factor for equipment age, as set forth in the current *Blue Book*, will both be applied to the basic rate. An additive payment equal to 100% percent of the *Blue Book* estimated operating cost per hour will also be paid for all hours equipment is in use. This additive payment will be full compensation for fuel, lubricants, repairs, servicing (greasing, fueling, and oiling), small tools, and other incidentals.

If rental rates for the equipment actually being used in the work are not listed in the *Blue Book*, the Design-Build Team will receive the prevailing rental rates being paid for such equipment in the area where the project is located. An additive payment equal to 15 percent of the prevailing rental rate will also be paid for all hours equipment is in use. This additive payment will be full compensation for fuel, lubricants, repairs, servicing (greasing, fueling, and oiling), small tools, and other incidentals.

Hourly rental rates for equipment held in ready as directed by the Engineer will be 50 percent of the rate paid for equipment in use. An additive payment will not be made for equipment held in ready. When equipment is in use less than 40 hours for any given week and is held in ready as directed by the Engineer, payment for held in ready time will be allowed for up to 40 hours, less hours in use. When payment is made for equipment held in ready as directed by the Engineer, the payment for held in ready time will be allowed for up to 8 hours in a day less hours in use.

Hourly rental rates for idle equipment held in ready in accordance with Article 104-4 will be 50 percent of the rate paid for equipment in use. Hourly rental rates for idle equipment held in ready in accordance with Article 104-4 which that is rented from a commercial rental agency will be paid for in accordance with the invoice rate for the equipment. An additive payment will not be made for idle equipment. When equipment is in use less than 40 hours for any given week and is held in ready as idle equipment in accordance with Article 104-4, payment for idle equipment time will be allowed for up to 40 hours, less hours in use. When payment is made for idle equipment held in ready in accordance with Article 104-4, the payment for idle equipment time held in ready will be allowed for up to 8 hours in a day less hours in use.

In the event the Design-Build Team does not possess or have readily available such equipment necessary for the performance of the work and such equipment is rented from a commercial rental agency, the Design-Build Team will receive payment based on the approved invoice rate for the equipment.

An additive payment equal to 15 percent of the calculated hourly invoice rate will also be paid for all hours equipment is in use. This additive payment will be full compensation for fuel, lubricants, repairs, servicing (greasing, fueling and oiling), small tools, and other incidentals. The commercial rental agency shall not be the Design-Build Team or an affiliate of the Design-Build Team.

No compensation will be made for the use of equipment not authorized by the Engineer.

The Design-Build Team will be reimbursed for the actual transportation costs for equipment which the Design-Build Team is directed to furnish. Such payment will be limited to transportation costs from the nearest source of available equipment. If equipment is not returned to the point of origin, but is transported to another location, transportation costs will not exceed the cost of return to the point of origin. Rental for such equipment will not be paid when the equipment is being transported. The Design-Build Team will shall furnish records to the Engineer to verify the actual transportation costs for equipment.

The Design-Build Team will shall provide to the Engineer for approval a listing of all equipment and attachments to be utilized in the prosecution of the work. The list will shall include the manufacturer's name, type, model, serial number, and year of manufacture. The list will shall also include the invoice rate for equipment rented from a commercial rental agency. It will shall be the Design-Build Team's responsibility to verify the age of the equipment in a manner acceptable to the Engineer. Where such verification is not available, the rate adjustment factor used will be for the oldest equipment listed in the Blue Book.

The above prices and payments will be full compensation for fuel, lubricants, cutting edges, all repairs, and all other operating and maintenance costs other than operator's wages.

- (E) Owner-Operated Equipment.** For all owner-operated equipment authorized by the Engineer to be used on the specific force account work, the Design-Build Team will receive rental payment equal to the existing contract rate(s) with no additive as provided in Items 109-3(1A), 109-3(2B), 109-3(4D) and 109-3(H8). When existing contract rate(s) have not been established, the Design-Build Team will shall submit the proposed rate(s) for the owner-operated equipment with sufficient documentation as deemed necessary by the Eengineer for approval.

For fully maintained and operated trucks used for the specific force account work, the Ccontractor will receive rental payment equal to the existing contract rate(s) with no additive as provided in Items 109-3(1A), 109-3(2B), 109-3(4D) and 109-3(8H). When existing contract rate(s) have not been established, the prevailing industry rate(s) for fully maintained and operated trucks will be used for the specific force account work with approval of the Engineer.

For the purposes of force account work, owner-operated equipment, including fully maintained and operated trucks, will be considered subcontractors. No additional additives other than those allowed under Item 109-3(7G) will be allowed.

- (F) **Miscellaneous.** No additional allowance will be made for general superintendence, the use of manually powered tools, or other costs for which no specific allowance is herein provided.
- (G) **Subcontracting.** For administrative costs of the Design-Build Team in connection with approved subcontract work at any level and the use of owner-operated equipment at any level, the Design-Build Team will receive an additive amount in accordance with the rate schedule shown below of the total cost of such subcontracted work. The total cost of such subcontracted work will include applicable labor and additive, bond and insurance, materials, and equipment costs incurred by the subcontractor; overhead and profit computed in accordance with Items 109-3(1A) through 109-3(4D), 109-3(6F), 109-3(8H) and 109-3(9I); and costs for owner-operated equipment, including fully maintained and operated trucks in accordance Item 109-3(5E). No additional additives will be allowed.

<u>Total Cost of Subcontract Work</u>	<u>Rate Schedule</u>
\$0 - \$10,000	10%
Above \$10,000	\$1,000 + 5% Above \$10,000

- (H) **Overhead and Profit.** An additive payment equal to 10 percent of the specific force account total will be paid to the Design-Build Team. This specific force account total is exclusive of the portion of the work included with Item 109-3(3C), Materials, Item 109-3(5E), Owner-Operated Equipment and Item 109-3(7G), Subcontracting. This payment will be full compensation for all costs including but not limited to home office and field overhead, burdens, and profit associated with the specific force account work.

An additive payment equal to 10 percent of the specific force account total for approved subcontract work will also be paid to the subcontractor for overhead and profit. This specific force account total for subcontract work is exclusive of the portion of the work included with Item 109-3(3C), Materials and Item 109-3(5E), Owner-Operated Equipment. This payment will be full compensation for all costs including but not limited to home office and field overhead, burdens, and profit associated with the specific force account subcontracted work. No additional additivesadditional additives will be allowed.

- (I) **Bond and Insurance.** For property damage and liability insurance premiums and bond premiums on the specific force account work, the Design-Build Team will receive the actual cost. The Design-Build Team willshall furnish satisfactory evidence to the Engineer of the rate or rates paid for such insurance and bond.

An annualized composite percentage may be used to determine the cost for bond and insurance. Insurance costs will be limited to the direct costs associated with the specific force account work. The Design-Build Team willshall furnish satisfactory evidence to the Engineer of the annualized composite percentage for the bond and insurance.

- (J) General.** The Engineer will maintain the payment records of work performed on a force account basis. The Design-Build Team will shall compare records of work with the Engineer at the end of each day on which such work is in progress.

Any contention the Design-Build Team may have for an extension in the completion date, intermediate completion date, or intermediate completion time, due to performance of specific force account work will be considered as provided in Article 108-10.

109-4 PARTIAL PAYMENTS.

(A) General:

Partial payments will be based upon progress estimates prepared by the Engineer at least once each month on the date established by the Engineer. Partial payments may be made twice each month if in the judgment of the Engineer the amount of work performed is sufficient to warrant such payment. No partial payment will be made when the total value of work performed since the last partial payment amounts to less than \$10,000.00. Partial payments will be approximate only and will be subject to correction in the final estimate and payment.

Partial payments for the lump sum design-build price shall be based on a certified Schedule of Payments submitted by the successful Design-Build proposer and approved by the Engineer. The certification shall indicate the Design-Build proposer has reviewed the information submitted and the information accurately represents the work performed for which payment is requested. The certified Schedule of Payments shall be submitted not less than 30 calendar days after the date of award. Each item on the certified Schedule of Payments shall be assigned a cost and quantity and shall be identified as an activity on the project schedule. A revised certified Schedule of Payments shall be submitted with each update of the CPM of Record as described in Article 108-2 or when requested by the Engineer. A certified copy of the Table of Values shall also be submitted with each payment request. The certification of the Table of Values shall indicate the Design-Builder has reviewed the information submitted and the information accurately represent the materials for the work performed for which payment is requested. The certification for the Table of Values shall also indicate the Design-Builder has performed material sampling and testing in accordance with the contract requirements.

The Engineer will withhold an amount sufficient to cover anticipated liquidated damages as determined by the Engineer.

109-5 PAYMENT FOR MATERIAL TO BE USED IN THE WORK.

(A) Material Delivered on the Project:

When so authorized by the Engineer, partial payments will be made up to 90 percent of the delivered cost of materials on hand that are to be incorporated in the work, provided that such materials have been delivered on or in close proximity to the project and stored in an acceptable manner. Material payments will be allowed when 90 percent of the accumulated costs of unpaid invoices are equal to or greater than \$10,000.00, materials have been inspected and approved by the Engineer, and the documents listed in Subarticle 109-5(C) have been furnished to the Engineer.

(B) Material Stored at Fabricator's Facilities or Design-Build Team's Facilities:

When so authorized by the Engineer, partial payments will be made up to 90 percent of the invoiced cost, exclusive of delivery cost, for bulky materials requiring fabrication at an off site location that are durable in nature and represent a significant portion of the project cost, if it has been determined by the Engineer, that the material cannot be reasonably stockpiled in the vicinity of the work. Material payments will be allowed when the materials have been inspected and approved by the Engineer and the documents listed in Subarticle 109-5(C) have been furnished to the Engineer.

(C) Required Documents:

1. Written consent of surety to make such partial payments,
2. Bill of Sale from the Design-Build Team to the Department,
3. Copy of invoice from material supplier verifying the cost of the material.

(D) General Requirements:

The partial payments will be made on the conditional basis that the material meets the requirements of the contract and will be incorporated into the project. The Design-Build Team shall reimburse the Department for all partial payments for material paid for, but not incorporated into the project.

Partial payments for materials on hand will not constitute acceptance, and any faulty material will be rejected even though previous payment may have been made for same in the estimates.

Partial payment will not be made for fuel, supplies, form lumber, falsework, or used materials.

Partial payments will not be made on seed or any living or perishable plant materials.

Partial payment requests shall not be submitted by the Design-Build Team until those items requested have corresponding signed and sealed RFC plans as outlined in the *Design-Build Submittal Guidelines*.

109-6 PAYMENT FOR LEFTOVER MATERIALS.

Payment will be made to the Design-Builder for materials meeting the requirements of the contract which were to have been permanently incorporated into the work or were to remain the property of the Department but due to revisions or elimination of items of work by the Engineer, due to changes in the scope, or due to termination of the contract are not used in the work. The Design-Builder upon request will be reimbursed for the verified actual cost of such material delivered to a site designated by the Engineer, including any handling charges less any discount, but in no event shall payment exceed that which would have been made at the contract unit or lump sum price for the completed work.

The Design-Builder shall furnish invoices and cost records to the Engineer to verify the actual cost of materials, handling charges, discounts which were taken, and transportation charges. No percentage additive will be added to the verified cost of such material.

No payment will be made for loss of anticipated profits and no other payment will be made for leftover materials except as listed above.

109-7 COMPENSATION PAID AT CONTRACT PRICES.

Except as provided for by this article, payment for work performed will be made at the contract unit price or the contract lump sum price, as the case may be. Payment shall be made at the adjusted contract unit or lump sum price, as applicable, when a price adjustment or pay factor is provided for by the Specifications or as determined by the Engineer in accordance with Article 105-3. The Design-Builder shall not be paid for any work performed for which there is not a contract price, nor shall the Design-Builder receive additional compensation over and above the contract price for work performed or for extra work performed, except for work performed pursuant to an executed supplemental agreement or work performed in accordance with the applicable provisions of Section 104.

109-8 FUEL PRICE ADJUSTMENTS.

This section is replaced by the Project Special Provision entitled "Fuel Price Adjustment" contained elsewhere in this Design-Build Package.

109-9 FINAL PAYMENT.

The Engineer will notify the Design-Builder giving the apparent liquidated damages, if any assessed. After the Design-Builder submits the documents listed in Article 109-10, the entire sum found to be due after deducting all previous payments and all amounts to be retained or deducted under the provisions of the contract will be paid the Design-Builder.

109-10 DOCUMENTS REQUIRED FOR THE PROCESSING OF THE FINAL ESTIMATE.

Prior to the processing of the final estimate, the following documents shall have been submitted to and accepted by the Engineer.

1. Statement of Consent of Surety on the contract bonds for payment of money due the Design-Builder.
2. Affidavit of the Design-Builder that all obligations and debts arising out of the construction have been satisfied, or affidavit which shall include a list of obligations not satisfied.
3. Written notice that the Design-Builder has no request for any extension in the completion date or any adjustment in compensation from that shown in the final estimate or in lieu thereof written notice presenting all request for adjustment of the final estimate setting forth full justification for such requests.
4. Any other documents that are required by the contract such as completed Form PR-47 and all reports, statements, and other information necessary for compliance with applicable labor regulations of the Federal Highway Administration.
5. As-constructed plans.
6. Final Material Certificate

Submission of false information in the documents required by this section shall be a basis for disqualifying the Design-Builder from further bidding in accordance with Article 102-16.

109-11 INTEREST ON FINAL PAYMENT.

Should final payment on a project not be made within 120 calendar days after the project final acceptance date, interest, at the average rate earned by the State Treasurer on the investment within the State's Short Term Fixed Income Investment Fund during the month preceding the date interest becomes payable, will be paid the Design-Builder on the final payment for the period beginning on the 121st day after final acceptance and extending to the date the final estimate is paid, provided that the documents required by Article 109-10 have been submitted within 30 days of the mailing of the notification outlined in Article 109-9. In the event the Design-Builder fails to submit the required documents within the stipulated 30 day period, and the final estimate is not paid until 120 calendar days following final acceptance of the project, the number of days on which interest accrues will be reduced by the number of days in excess of 30 that the Design-Builder requires to submit the document(s).

SECTION 150
MAINTENANCE OF TRAFFIC

150-1 GENERAL.

The Design-Builder will be required to maintain traffic within the limits of the project, including all existing roadways, which cross or intersect the project, unless otherwise provided in the contract or approved by the Engineer. Traffic shall be maintained from the time the Design-Builder begins work on the project site until acceptance of the project, including any periods during which the Design-Builder's operations are suspended, unless otherwise provided for in the contract or approved by the Engineer. The Design-Builder shall conduct his work in a safe manner, which will create a minimum amount of inconvenience to traffic.

The Design-Builder shall be responsible for maintaining in a safe, passable, and convenient condition, such part or parts of existing roads as are being used by him to maintain traffic within the limits of the project from the time the Design-Builder begins work on the project until acceptance of the project. As an exception to the above, the Department will be responsible for the removal of ice and snow from all portions of the project open to traffic.

Whenever it is necessary to utilize traffic control devices as shown in the contract, as determined by the Engineer, or in order to conform to the provisions of this section, the work of furnishing, erecting, operating, maintaining, covering, relocating, and removing traffic control devices shall be in accordance with the provisions of Division 11 & 12.

County : Union

Line #	Item Number	Sec #	Description	Quantity	Unit Cost	Amount
--------	-------------	-------	-------------	----------	-----------	--------

ROADWAY ITEMS

0001	0000900000-N	SP	GENERIC MISCELLANEOUS ITEM DESIGN AND CONSTRUCT	Lump Sum	L.S.	
------	--------------	----	--	----------	------	--

0907/Dec16/Q1.0/D900000/E1

Total Amount Of Bid For Entire Project :

FUEL USAGE FACTOR CHART AND ESTIMATE OF QUANTITIES

<u>Description of Work</u>	<u>Units</u>	<u>Fuel Usage Factor Diesel #2</u>	<u>Estimate of Quantities</u>
Unclassified and Borrow Excavation	Gal/CY	0.29	_____cy
Aggregate Base Course	Gal/Ton	0.55	_____tons
Aggregate for Cement Treated Base Course			
Portland Cement for Cement Treated Base Course			
Asphalt Concrete Base Course	Gal/Ton	2.90	_____tons
Asphalt Concrete Intermediate Course			
Asphalt Concrete Surface Course			
Open-Graded Asphalt Friction Course			
Sand Asphalt Surface Course, Type F-1			
Portland Cement Concrete Pavement	Gal/CY	0.98	_____cy
Structural Concrete			
Concrete Shoulders Adjacent to Pavement			

The above quantities represent a reasonable estimate of the total quantities anticipated, for each item, as pertaining to fuel price adjustments, and is representative of the design proposed in the Technical Proposal submitted under separate cover.

or

The Design-Build Team elects not to pursue reimbursement for Fuel Price Adjustments on this project.

AWARD LIMITS ON MULTIPLE PROJECTS

It is the desire of the Proposer to be awarded contracts, the value of which will not exceed a total of \$ _____, for those projects indicated below on which bids are being opened on the same date as shown in the Proposal Form. Individual projects shall be indicated by placing the project number and county in the appropriate place below. Projects not selected will not be subject to an award limit.

_____ (Project Number)	_____ (County)
_____ (Project Number)	_____ (County)
_____ (Project Number)	_____ (County)
_____ (Project Number)	_____ (County)

*If a Proposer desires to limit the total amount of work awarded to him in this letting, he shall state such limit in the space provided above in the second line of this form.

It is agreed that in the event that I am (we are) the successful Design Build Team on indicated projects, the total value of which is more than the above stipulated award limits, the Board of Transportation will award me (us) projects from among those indicated which have a total value not exceeding the award limit and which will result in the best advantage to the Department of Transportation.

**Signature of Authorized Person

**Only those persons authorized to sign bids under the provisions of Article 102-8, Item 7, shall be authorized to sign this form.

LISTING OF DBE SUBCONTRACTORS

Sheet _____ of _____

FIRM NAME AND ADDRESS	ITEM NO.	ITEM DESCRIPTION	AGREED UPON UNIT PRICE (*)	DOLLAR VOLUME OF SUBLET ITEM
CONTRACT NO.		COUNTY	FIRM	

THIS FORM MUST BE COMPLETED IN ORDER FOR THE BID TO BE CONSIDERED RESPONSIVE AND BE PUBLICLY READ. BIDDERS WITH NO DBE PARTICIPATION MUST SO INDICATE THIS ON THE FORM BY ENTERING THE WORD OR NUMBER ZERO.

LISTING OF DBE SUBCONTRACTORS

Sheet _____ of _____

FIRM NAME AND ADDRESS	ITEM NO.	ITEM DESCRIPTION	AGREED UPON UNIT PRICE (*)	DOLLAR VOLUME OF SUBLET ITEM
CONTRACT NO.				FIRM
COUNTY			FIRM	

LISTING OF DBE SUBCONTRACTORS

Sheet _____ of _____

FIRM NAME AND ADDRESS	ITEM NO.	ITEM DESCRIPTION	AGREED UPON UNIT PRICE (*)	DOLLAR VOLUME OF SUBLET ITEM
CONTRACT NO.		COUNTY	FIRM	

LISTING OF DBE SUBCONTRACTORS

Sheet _____ of _____

FIRM NAME AND ADDRESS	ITEM NO.	ITEM DESCRIPTION	AGREED UPON UNIT PRICE (*)	DOLLAR VOLUME OF SUBLET ITEM
CONTRACT NO. _____ COUNTY _____ FIRM _____				

COST OF CONSTRUCTION WORK ONLY \$ _____

(*) The Dollar Volume Shown In This Column Shall be Actual Price Agreed Upon by the Prime Contractor and the DBE Subcontractor, and These Prices Will Be Used to Determine The Percentage of the DBE Participation in this Contract.

**Dollar Volume of DBE Subcontractor \$ _____

Percentage of Total Contract bid Price _____ %

****MUST HAVE ENTRY EVEN IF FIGURE TO BE ENTERED IS ZERO.**

EXECUTION OF BID, NONCOLLUSION AFFIDAVIT AND DEBARMENT CERTIFICATION

The person executing the bid, on behalf of the Bidder, being duly sworn, solemnly swears (or affirms) that neither he, nor any official, agent or employee of the bidder has entered into any agreement, participated in any collusion, or otherwise taken any action which is in restraint of free competitive bidding in connection with this bid, and that the Bidder intends to do the work with its own bonafide employees or subcontractors and is not bidding for the benefit of another contractor.

In addition, execution of this bid in the proper manner also constitutes the Bidder's certification of "Status" under penalty of perjury under the laws of the United States in accordance with the Debarment Certification included elsewhere in the proposal form, provided that the Debarment Certification also includes any required statements concerning exceptions that are applicable.

SIGNATURE OF CONTRACTOR

(If a corporation uses this sheet)

(Print full name of corporation)

(Address as Prequalified)

Attest _____
(Secretary) (Assistant Secretary)
Delete inappropriate title

By _____
(President) (Vice President)
(Asst. Vice President)
Delete inappropriate title

Print Signer's Name

Print Signer's Name

NOTE - AFFIDAVIT MUST BE NOTARIZED

CORPORATE SEAL

Subscribed and sworn to before me this the
____ day of _____, 20 ____.

(Signature of Notary Public)

NOTARY SEAL:

of _____ County.

State of _____.

My Commission Expires: _____

EXECUTION OF BID, NONCOLLUSION AFFIDAVIT, AND DEBARMENT CERTIFICATION

The person executing the bid, on behalf of the Bidder, being duly sworn, solemnly swears (or affirms) that neither he, nor any official, agent or employee of the bidder has entered into any agreement, participated in any collusion, or otherwise taken any action which is in restraint of free competitive bidding in connection with this bid, and that the Bidder intends to do the work with its own bonafide employees or subcontractors and is not bidding for the benefit of another contractor.

In addition, execution of this bid in the proper manner also constitutes the Bidder's certification of "Status" under penalty of perjury under the laws of the United States in accordance with the Debarment Certification included elsewhere in the proposal form, provided that the Debarment Certification also includes any required statements concerning exceptions that are applicable.

SIGNATURE OF CONTRACTOR
(If a joint venture, use this sheet)

Instructions to Bidders: On Line (1), print the name of each contractor. On Line (2), print the name of one of the joint venturers and execute below in the appropriate manner and furnish in the following lines all information required by Article 102-8 of the Specifications. On Line (3), print the name of the other joint venturer and execute below in the appropriate manner and furnish all information required by said article of the Specifications. For correct form of execution and information required for execution of this sheet by an individual, see Signature Sheets 3 and 4; for a corporation, see Signature Sheet 1; and for a partnership, see Signature Sheet 5.

(1) _____ and _____
A Joint Venture

(2) _____ (Seal)
(Name of Contractor)

Witness or Attest By _____

Print Signer's Name Print Signer's Name
If a corporation, affix corporate seal:

and
(3) _____ (Seal)
(Name of Contractor)

(Address as Prequalified)

Witness or Attest By _____

Print Signer's Name Print Signer's Name
If a corporation, affix corporate seal:

NOTE - AFFIDAVIT MUST BE NOTARIZED For Line (2) NOTE - AFFIDAVIT MUST BE NOTARIZED For Line (3)

Subscribed and sworn to before me
this the ____ day of _____, 20____.

Subscribed and sworn to before me
this the ____ day of _____, 20____.

(Signature of Notary Public & Seal)

(Signature of Notary Public & Seal)

of _____ County.

of _____ County.

State of _____.

State of _____.

My Commission Expires: _____
Signature Sheet 2 (Bid) - Joint Venture

My Commission Expires _____.

EXECUTION OF BID, NONCOLLUSION AFFIDAVIT, AND DEBARMENT CERTIFICATION

The person executing the bid, on behalf of the Bidder, being duly sworn, solemnly swears (or affirms) that neither he, nor any official, agent or employee of the bidder has entered into any agreement, participated in any collusion, or otherwise taken any action which is in restraint of free competitive bidding in connection with this bid, and that the Bidder intends to do the work with its own bonafide employees or subcontractors and is not bidding for the benefit of another contractor.

In addition, execution of this bid in the proper manner also constitutes the Bidder's certification of "Status" under penalty of perjury under the laws of the United States in accordance with the Debarment Certification included elsewhere in the proposal form, provided that the Debarment Certification also includes any required statements concerning exceptions that are applicable.

SIGNATURE OF CONTRACTOR
(If an individual doing business under a firm name, use this sheet)

Name of Contractor _____ trading
(Print individual name)

Witness

and doing business as _____
(Print firm name)

Print Signer's Name

(Address as Prequalified)

Signature of Contractor _____
(Individually)

Print Signer's Name

NOTE - AFFIDAVIT MUST BE NOTARIZED

Subscribed and sworn to before me this the _____ day of _____, 20____.

NOTARY SEAL

(Signature of Notary Public)

of _____ County.

State of _____.

My Commission Expires: _____

EXECUTION OF BID, NONCOLLUSION AFFIDAVIT, AND DEBARMENT CERTIFICATION

The person executing the bid, on behalf of the Bidder, being duly sworn, solemnly swears (or affirms) that neither he, nor any official, agent or employee of the bidder has entered into any agreement, participated in any collusion, or otherwise taken any action which is in restraint of free competitive bidding in connection with this bid, and that the Bidder intends to do the work with its own bonafide employees or subcontractors and is not bidding for the benefit of another contractor.

In addition, execution of this bid in the proper manner also constitutes the Bidder's certification of "Status" under penalty of perjury under the laws of the United States in accordance with the Debarment Certification included elsewhere in the proposal form, provided that the Debarment Certification also includes any required statements concerning exceptions that are applicable.

SIGNATURE OF CONTRACTOR

(If an individual doing business in his own name, use this sheet)

Name of Contractor _____
(Print)

(Address as Prequalified)

Witness

Signature of Contractor _____
(Individually)

Print Signer's Name

Print Signer's Name

NOTE - AFFIDAVIT MUST BE NOTARIZED

Subscribed and sworn to before me this the _____ day of _____, 20____.

NOTARY SEAL

(Signature of Notary Public)

of _____ County.

State of _____.

My Commission Expires: _____

12/21/99

EXECUTION OF BID, NONCOLLUSION AFFIDAVIT, AND DEBARMENT CERTIFICATION

The person executing the bid, on behalf of the Bidder, being duly sworn, solemnly swears (or affirms) that neither he, nor any official, agent or employee of the bidder has entered into any agreement, participated in any collusion, or otherwise taken any action which is in restraint of free competitive bidding in connection with this bid, and that the bidder intends to do the work with its own bonafide employees or subcontractors and is not bidding for the benefit of another contractor.

In addition, execution of this bid in the proper manner also constitutes the bidder's certification of "Status" under penalty of perjury under the laws of the United States in accordance with the Debarment Certification included elsewhere in the proposal form, provided that the Debarment Certification also includes any required statements concerning exceptions that are applicable.

SIGNATURE OF CONTRACTOR

(If a partnership, use this sheet)

(Print Name of Partnership)

(Address as Prequalified)

Witness By Partner

Print Signer's Name

Print Signer's Name

NOTE - AFFIDAVIT MUST BE NOTARIZED

Subscribed and sworn to before me this the
____ day of _____, 20 ____.

NOTARY SEAL

(Signature of Notary Public)

of _____ County.

State of _____.

My Commission Expires: _____

EXECUTION OF BID, NONCOLLUSION AFFIDAVIT, AND DEBARMENT CERTIFICATION

The person executing the bid, on behalf of the Bidder, being duly sworn, solemnly swears (or affirms) that neither he, nor any official, agent or employee of the bidder has entered into any agreement, participated in any collusion, or otherwise taken any action which is in restraint of free competitive bidding in connection with this bid, and that the Bidder intends to do the work with its own bonafide employees or subcontractors and is not bidding for the benefit of another contractor.

In addition, execution of this bid in the proper manner also constitutes the Bidder's certification of "Status" under penalty of perjury under the laws of the United States in accordance with the Debarment Certification included elsewhere in the proposal form, provided that the Debarment Certification also includes any required statements concerning exceptions that are applicable.

SIGNATURE OF CONTRACTOR
(Limited Liability Company, use this sheet)

Name of Contractor _____
(Print firm name)

(Address as Prequalified)

Signature of Manager _____
(Individually)

Print Signer's Name

NOTE - AFFIDAVIT MUST BE NOTARIZED

Subscribed and sworn to before me this the
_____ day of _____, 20_____.

NOTARY SEAL

(Signature of Notary Public)

of _____ County.

State of _____.

My Commission Expires: _____

2/16/99

Contract No: C 201304

County: Union

ACCEPTED BY THE
DEPARTMENT OF TRANSPORTATION

Contract Officer

Date

Execution of Contract and Bonds
Approved as to Form:

Attorney General

DEBARMENT CERTIFICATION OF BIDDERS

Instructions & conditions for certification

1. By signing and submitting this proposal, the bidder is providing the certification set out below.
2. The inability of a bidder to provide the certification required below will not necessarily result in denial of participation in this contract. If the certification is not provided, the bidder must submit an explanation (exception) of why it cannot provide the certification set out below. The certification or explanation (exception) will be considered in connection with the Department's determination whether to award the contract. However, failure of the prospective bidder to furnish a certification or an explanation (exception) may be grounds for rejection of the bid.
3. The certification in this provision is a material representation of fact upon which reliance is placed when the Department determines whether or not to award the contract. If it is later determined that the bidder knowingly rendered an erroneous certification, in addition to other remedies available to the Federal Government, the Department may terminate this contract for cause of default.
4. The prospective bidder shall provide immediate written notice to the Department if at any time the bidder learns that its certification was erroneous when submitted or has become erroneous by reason of changed circumstances.
5. The terms "covered transaction," "debarred," "suspended," "ineligible," "lower tier covered transaction," "participant," "person," "primary covered transaction," "principal," "proposal," and "voluntarily excluded," as used in this provision, have the meanings set out in the Definitions and Coverage sections of the rules implementing *Executive Order 12540*. A copy of the Federal Rules requiring this certification and detailing the definitions and coverages may be obtained from the Contract Officer of the Department.
6. The bidder agrees by submitting this bid that, should the contract be awarded, it shall not knowingly enter into any lower tier covered transaction with a person who is debarred, suspended, declared ineligible, or voluntarily excluded from participation in this contract, unless authorized by the Department.
7. The prospective bidder further agrees by submitting this proposal that it will include the Federal-Aid Provision titled "Required Contract Provisions Federal-Aid Construction Contract" (Form FHWA PR 1273) provided by the Department, without subsequent modification, in all lower tier covered transactions.

8. The prospective bidder may rely upon a certification of a prospective participant in a lower tier covered transaction that it is not debarred, suspended, ineligible, or voluntarily excluded from the covered transaction, unless it knows that the certification is erroneous. A participant may decide the method and frequency by which it determines the eligibility of its principals.
9. Nothing contained in the foregoing shall be construed to require establishment of a system of records in order to render in good faith the certification required by this provision. The knowledge and information of a participant is not required to exceed that which is normally possessed by a prudent person in the ordinary course of business dealings.
10. Except for transactions authorized under paragraph 6 of these instructions, if the successful bidder knowingly enters into a lower tier covered transaction with a person who is suspended, debarred, ineligible, or voluntarily excluded from participation in this transaction, in addition to other remedies available to the Federal Government, the Department may terminate this transaction for cause of default.

DEBARMENT CERTIFICATION

The bidder certifies to the best of its knowledge and belief, that it and its principals:

- a. Are not presently debarred, suspended, proposed for debarment, declared ineligible, or voluntarily excluded from covered transactions by any Federal department or agency;
- b. Have not within a three-year period preceding this proposal been convicted of or had a civil judgment rendered against them for commission of fraud or a criminal offense in connection with obtaining, attempting to obtain, or performing a public (Federal, State or local) transaction or contract under a public transaction; violation of Federal or State antitrust statutes or commission of embezzlement, theft, forgery, bribery, falsification or destruction of records; making false statements; or receiving stolen property;
- c. Are not presently indicted for or otherwise criminally or civilly charged by a governmental entity (Federal, State or local) with commission of any of the offenses enumerated in paragraph b. of this certification; and
- d. Have not within a three-year period preceding this proposal had one or more public transactions (Federal, State or local) terminated for cause or default.

Where the prospective bidder is unable to certify to any of the statements in this certification, it shall attach an explanation to this proposal.

IF AN EXPLANATION, AS PROVIDED IN THE ABOVE DEBARMENT CERTIFICATION, HAS BEEN ATTACHED TO THE PROPOSAL, PLEASE CHECK THE BOX SHOWN BELOW:

An explanation has been attached to the proposal.