

-- STATE OF NORTH CAROLINA--
DEPARTMENT OF TRANSPORTATION
RALEIGH, N.C.



THIRD INDUSTRY DRAFT FINAL
REQUEST FOR PROPOSAL

**DESIGN-BUILD PROJECT
TIP R-2721A**

December 14, 2018

January 10, 2019

VOID FOR BIDDING



DATE AND TIME OF TECHNICAL PROPOSAL SUBMISSION: **March 27, 2019 BY 4:00 PM**

DATE AND TIME OF PRICE PROPOSAL SUBMISSION: **April 8, 2019 BY 4:00 PM**

DATE AND TIME OF PRICE PROPOSAL OPENING: **April 16, 2019 AT 2:00 PM**

CONTRACT ID: C204196

WBS ELEMENT NO. 37673.3.GV3

FEDERAL-AID NO. NHP-0540(041)

COUNTY: Wake

ROUTE NO. NC 540 (Triangle Expressway)

MILES: 4.356

LOCATION: Triangle Expressway Southeast Extension from NC 55 Bypass to east of Pierce Olive Road (SR 1389)

TYPE OF WORK: DESIGN-BUILD AS SPECIFIED IN THE SCOPE OF WORK
CONTAINED IN THE REQUEST FOR PROPOSALS

NOTICE:

ALL PROPOSERS SHALL COMPLY WITH ALL APPLICABLE LAWS REGULATING THE PRACTICE OF GENERAL CONTRACTING AS CONTAINED IN CHAPTER 87 OF THE GENERAL STATUTES OF NORTH CAROLINA WHICH REQUIRES THE PROPOSER TO BE LICENSED BY THE N.C. LICENSING BOARD FOR CONTRACTORS WHEN BIDDING ON ANY NON-FEDERAL AID PROJECT WHERE THE BID IS \$30,000 OR MORE, EXCEPT FOR CERTAIN SPECIALTY WORK AS DETERMINED BY THE LICENSING BOARD. PROPOSERS SHALL ALSO COMPLY WITH ALL OTHER APPLICABLE LAWS REGULATING THE PRACTICES OF ELECTRICAL, PLUMBING, HEATING AND AIR CONDITIONING AND REFRIGERATION CONTRACTING AS CONTAINED IN CHAPTER 87 OF THE GENERAL STATUTES OF NORTH CAROLINA. NOT WITHSTANDING THESE LIMITATIONS ON BIDDING, THE PROPOSER WHO IS AWARDED ANY PROJECT SHALL COMPLY WITH CHAPTER 87 OF THE GENERAL STATUTES OF NORTH CAROLINA FOR LICENSING REQUIREMENTS WITHIN 60 CALENDAR DAYS OF BID OPENING, REGARDLESS OF FUNDING SOURCES.

5% BID BOND OR BID DEPOSIT REQUIRED

**PROPOSAL FORM FOR THE CONSTRUCTION OF CONTRACT NO. C204196
IN WAKE COUNTY, NORTH CAROLINA**

Date _____ 20 _____

**DEPARTMENT OF TRANSPORTATION,
RALEIGH, NORTH CAROLINA**

The Design-Build Team herein acknowledges that it has carefully examined the location of the proposed work to be known as Contract No. C204196; has carefully examined the Final Request for Proposals (RFP) and all addendums thereto, specifications, special provisions, the form of contract, and the forms of contract payment bond and contract performance bonds, which are acknowledged to be part of the Contract; and thoroughly understands the stipulations, requirements and provisions. The undersigned Design-Build Team agrees to be bound upon their execution of the Contract and including any subsequent award to them by the Secretary of Transportation in accordance with this Contract to provide the necessary contract payment bond and contract performance bond within fourteen calendar days after written solicitation of said bonds is received by them.

The undersigned Design-Build Team further agrees to provide all necessary materials, machinery, implements, appliances, tools, labor, and other means of construction, except as otherwise noted, to perform all the work and required labor to design, construct and complete all the work necessary for State Highway Contract No. C204196 in Wake County by no later than the dates(s) specified in the Final RFP or Technical Proposal, whichever is earlier, and in accordance with the requirements of the Engineer, the Final RFP and Addenda thereto, the 2018 *Standard Specifications for Roads and Structures*, specifications prepared by the Department, the Technical Proposal prepared by the Design-Build Team, at the lump sum price(s) bid by the Design-Build Team in their Price Proposal.

The Design-Build Team shall provide signed and sealed documents prepared by the Design-Build Team, which specifications and plans show the details covering this project and adhere to the items noted above.

The Design-Build Team acknowledges that project documents furnished by the Department or the North Carolina Turnpike Authority are preliminary and provided solely to assist the Design-Build Team in the development of the project design. Unless otherwise noted herein, the Department or the North Carolina Turnpike Authority do not warrant or guarantee the sufficiency or accuracy of any information furnished by the Department or the North Carolina Turnpike Authority.

The Department, nor the North Carolina Turnpike Authority, warrant or guarantee the sufficiency or accuracy of any investigations made, nor the interpretations made or opinions of the Department or the North Carolina Turnpike Authority as to the type of materials and conditions to be encountered at the project site. The Design-Build Team is advised to make such independent investigations, as they deem necessary to satisfy their self as to conditions to be encountered on this project. The Design-Build Team shall have no claim for additional compensation or for an extension of contract time for any reason resulting from the actual conditions encountered at the site differing from those indicated in any of the information or

documents furnished by the Department or the North Carolina Turnpike Authority except as may be allowed under the provisions of the Standard Specifications.

Although the North Carolina Turnpike Authority has furnished preliminary designs for this project, unless otherwise noted herein, the Design-Build Team shall assume full responsibility, including liability, for the project design, including the use of portions of the North Carolina Turnpike Authority design, modification of such design, or other designs as may be submitted by the Design-Build Team.

The Design-Build Team shall be fully and totally responsible for the accuracy and completeness of all work performed under this contract, and shall indemnify and hold the Department and the North Carolina Turnpike Authority harmless for any additional costs and all claims against the Department, North Carolina Turnpike Authority, or the State which may arise due to errors or omissions of the Department or the North Carolina Turnpike Authority in furnishing the preliminary project designs and information, and of the Design-Build Team in performing the work.

The published volume entitled *North Carolina Department of Transportation, Raleigh, Standard Specifications for Roads and Structures*, January 2018, as well as, all design manuals, policy and procedures manuals, and AASHTO publications and guidelines referenced in the Request For Proposals, with all amendments and supplements thereto, are by reference, incorporated and made part of this contract; that, except as herein modified, all the design, construction and Construction Engineering Inspection included in this contract is to be done in accordance with the documents noted above and under the direction of the Engineer.

If the Design-Build Proposal is accepted and the award is made, the Technical Proposal submitted by the Design-Build Team is by reference, incorporated and made part of this contract. The contract is valid only when signed either by the Contract Officer or such other person as may be designated by the Secretary to sign for the Department of Transportation. The conditions and provisions herein cannot be changed except by written approval as allowed by the Request for Proposals.

Accompanying the Design-Build Proposal shall be a bid bond secured by a corporate surety, or certified check payable to the order of the Department of Transportation, for five percent of the total bid price, which deposit is to be forfeited as liquidated damages in case this bid is accepted and the Design-Build Team shall fail to provide the required payment and performance bonds with the Department of Transportation, under the condition of this proposal, within 14 calendar days after the written solicitation of said bonds is received by them, as provided in the Contract; otherwise said deposit will be returned to the Design-Build Team.

TABLE OF CONTENTS

COVER SHEET

PROPOSAL SHEETS

PROJECT SPECIAL PROVISIONS	<i>PAGE NO.</i>
Definitions.....	1
Contract Time and Liquidated Damages	1
Proposal Validity Period	2
Price Proposal Index	4
Substantial Completion Bonus.....	4
Intermediate Contract Time #1 and Liquidated Damages	5
Other Liquidated Damages	6
Project Schedule.....	6
Payout Schedule.....	6
Mobilization.....	7
Substantial Completion.....	7
Submittal of Quantities, Fuel Base Index Price and Opt-Out Option.....	8
Individual Meetings with Proposers	9
Execution of Bid, Non-Collusion Affidavit, Debarment Certification, and Gift Ban Certification	10
Submission of Design-Build Proposal	10
Alternative Technical Concepts and Confidential Questions	11
Schedule of Estimated Completion Progress.....	16
Disadvantaged Business Enterprise	17
Certification for Federal-Aid Contracts	30
Contractor's License Requirements.....	31
U. S. Department of Transportation Hotline – Cargo Preference Act.....	31
Subsurface Information.....	32
Cooperation Between Contractors	32
Price Proposal Documentation.....	33
Dispute Review Board	36
Three Year Guarantee	46
Permanent Vegetation Establishment	64
Erosion & Sediment Control / Stormwater Certification.....	64
Procedure for Monitoring Borrow Pit Discharge.....	69
Clearing and Grubbing.....	71
Burning Restrictions	72
Building and Appurtenance Removal / Demolition.....	72
Automated Machine Guidance (AMG)	72
Automated Fine Grading.....	73
Final Surface Testing	73
Reinforced Concrete Pipe Design	73
Drainage Pipe	75

Cement and Lime Stabilization of Sub-Grade Soils	75
Price Adjustments for Asphalt Binder	79
Price Adjustments - Asphalt Concrete Plant Mix	79
Black Epoxy Pavement Marking Material	80
Field Office	83
Geotextile for Pavement Stabilization	85
Nonwoven Geotextile Interlayer	86
International Roughness Index	88
Roller Compacted Concrete	88
Diamond Grinding Concrete Pavement	97
Sound Barrier Wall	99
Dynamic Message Sign	101
NTCIP Requirements	122
DMS Testing Requirements	132
DMS Assemblies	135
Overhead and Dynamic Message Sign Foundations	138
CCTV Camera Equipment Infrastructure	140
Microwave Vehicle Detection Infrastructure	146
Communications Hardware	148
Electrical Service	155
CCTV Camera and MVD Metal Poles	162
Lighting	170
Roadway Lighting Foundations	182
Foundations and Anchor Rod Assemblies for Metal Poles	185
Testing and Acceptance	191
Work Zone Pattern Masking	195
High Visibility Traffic Control Devices	199
Sequential Flashing Warning Lights	200
GENERAL	204
 SCOPES OF WORK	
Roadway	223
Pavement Management	241
Structures	251
Hydraulics	256
Geotechnical Engineering	265
Environmental Permits	275
Transportation Management	281
Pavement Markings	305
All Electronic Tolling Toll Zone Infrastructure	308
Signing	319
Right of Way	330

Utilities Coordination.....	339
Erosion and Sedimentation Control.....	348
Traffic Signals and Signal Communications	362
Geoenvironmental.....	374
ITS.....	376
Public Involvement and Information	388
Aesthetic Design	391
Lighting.....	395

STANDARD SPECIAL PROVISIONS

Plant and Pest Quarantines.....	397
Bridge Approach Fills.....	398
Alternate Bridge Approach Fills for Integral Abutments	400
Asphalt Concrete Plant Mix Pavements	402
Subsurface Drainage	404
Guardrail End Units, Type TL-2.....	404
Guardrail End Units, Type TL-3.....	405
Guardrail Anchor Units and Temporary Guardrail Anchor Units	406
Impact Attenuator Unit, Type TL-2	406
Impact Attenuator Unit, Type TL-3	407
Temporary Shoring.....	408
On-the-Job Training.....	419
Availability of Funds – Termination of Contracts.....	422
NCDOT General Seed Specifications for Seed Quality	423
Title VI and Nondiscrimination.....	426
Minority and Female Employment Requirements.....	435
Required Contract Provisions Federal-Aid Construction Contracts.....	438
General Decision Wages.....	447
Errata.....	452
Division One	453

PROPOSAL FORMS - ITEMIZED SHEET, ETC.

Itemized Proposal Sheet	
Fuel Usage Factor Chart and Estimate of Quantities	
Listing of DBE Subcontractors	
Execution of Bid, Non-Collusion Affidavit, Debarment Certification and Gift Ban Certification	
Signature Sheet	

***** PROJECT SPECIAL PROVISIONS *******DEFINITIONS**

Throughout this Request for Proposals (RFP), the 2018 *NCDOT Standard Specifications for Roads and Structures*, the RFP, and other contract documents the terms “NCDOT”, “Department”, or other names as reference to the Department of Transportation, apply equally to the North Carolina Turnpike Authority (NCTA) and the terms “Board”, “Board of Transportation”, or other names as reference to the North Carolina Board of Transportation apply equally to the Board of the North Carolina Turnpike Authority. The Board of the North Carolina Turnpike Authority is herein referred to as the Authority Board. In addition, the terms Department of Transportation, Department, and NCDOT are synonymous and are defined so as to include the North Carolina Turnpike Authority as described in Article 6H of Chapter 136 of the North Carolina General Statutes and transferred to the Department of Transportation pursuant to G.S. 136-89.182(b).

CONTRACT TIME AND LIQUIDATED DAMAGES

(4-29-18)

SP1 G07

The Authority will issue a written Limited Notice to Proceed to the Design-Build Team immediately upon execution of the Contract in accordance with the Project Special Provision, *Proposal Validity Period*. The Design-Build Team shall begin performance of the Work as directed in the Notice to Proceed, and shall thereafter perform the Work in accordance with the approved cost-loaded CPM Schedule, so as to achieve timely completion of the Project by the applicable completion dates specified herein. Any design or construction activities started or performed before receipt of the written Notice to Proceed including, without limitation, design efforts beyond those required for the generation of the Technical Proposal, the order or purchase of materials and/or equipment, mobilization of equipment, or other associated activities, shall be at the risk and expense of the Design-Build Team. The first day of Contract performance will be specified in the Notice to Proceed.

Regardless of the issuance of a Limited or Unlimited Notice to Proceed, no physical work in jurisdictional waters and/or wetlands shall begin until a meeting between the Department, applicable Regulatory Agencies, and the Design-Build Team is held.

Unless otherwise stipulated in the RFP, when observation periods are required by the Contract, the observation periods are not a part of the Work to be completed by the completion dates and/or intermediate contract times. Should an observation period extend beyond the Final Completion Date, either (1) the performance and payment bonds shall remain in full force and effect until the observations have been completed and the Work has been accepted, or (2) the Warranty Bond required in the *Three Year Guarantee* Project Special Provision shall clearly cover the observation periods.

The Substantial Completion Date for the Project is defined as the Substantial Completion Date proposed in the Technical Proposal by the Proposer who is awarded the contract. The Substantial Completion date thus proposed shall be no later than September 1, 2023. Subject to any time extensions approved in writing by the Authority, the Proposer shall be liable for liquidated damages in the amount of **Twenty Thousand dollars** (\$20,000.00) per calendar day for each day of delay in achieving Substantial Completion beyond the Substantial Completion Date proposed in the Technical Proposal. In the event that Substantial Completion occurs after September 23,

2023 and subject to any time extensions approved in writing by the Authority, the Proposer shall be liable for liquidated damages in the amount of **Thirty Thousand dollars** (\$30,000.00) per calendar day for each day of delay in achieving Substantial Completion beyond September 1, 2023.

The liquidated damages attributable to a delay in Substantial Completion as described above will continue to accrue until such time that Substantial Completion is achieved. Once Substantial Completion is achieved, liquidated damages for Final Completion will begin accruing in accordance with the below and be added to any liquidated damages that accrued as a result in a delay in the Substantial Completion.

The Final Completion Date for the Project is defined as the Final Completion Date proposed in the Technical Proposal by the Proposer who is awarded the contract. The Final Completion date thus proposed shall be no later than January 1, 2024. Subject to any time extensions approved in writing by the Authority, the Proposer will be liable for liquidated damages in the amount of **Five Thousand dollars** (\$5,000.00) per calendar day for each day of delay in achieving Final Completion.

By execution and submission of a Price Proposal, the Design-Build Team agrees and acknowledges that such liquidated damages are reasonable in order to compensate the Authority for damages it will incur as a result of delays in achieving Substantial Completion and Final Completion. Such damages include, without limitation, (1) loss of revenue for the Authority due to late service commencement, (2) loss of use, enjoyment and benefit of the Project and connecting transportation facilities by the general public, (3) additional oversight and administrative costs, and (4) debt service costs. The Design-Build Team further agrees and acknowledges that these liquidated damages are incapable of accurate measurement because of, among other things, the unique nature of the Project and the unavailability of a substitute.

Contract time extension(s) will be administered in accordance with the 2018 *Standard Specifications for Roads and Structures* and as may be modified in the Standard Special Provision entitled "Division One" contained elsewhere in the RFP. A contract time extension will apply to the Substantial Completion Date and the Final Completion Date provided the Design-Build Team can demonstrate that such delay is beyond the control of the Design-Build Team and that construction activities have been delayed (no remaining float on the longest path) as a direct result of the failure to issue Unlimited Notice to Proceed.

PROPOSAL VALIDITY PERIOD

The Financial Closing Date for full funding for this project is anticipated to occur in May 2019. However, advanced funding of up to \$100 Million is available (in the aggregate for R-2721A, R-2721B, and R-2828) to cover mobilization, design and right of way acquisition costs payable to the Design-Build Team under these Contracts, as well as utility relocation costs and the cost of right-of way borne directly by the Department.

Provided the Authority does not elect to pursue a Best and Final Offer, the Department intends to issue a Notice of Award to the Design-Build Team with the lowest Adjusted Price within 60 calendar days of the opening of Price Proposals. This Notice of Award will solicit the submission of contract payment and contract performance bonds. It is anticipated that a written Limited Notice to Proceed will be issued to the Design-Build Team immediately following execution of the Contract.

After the determination of the Design-Build Team with the apparent low Adjusted Price, but prior to Contract execution, and at the Design-Build Team's own risk, the Design-Build Team may elect to further the design of the project. If requested in writing by the Design-Build Team, the Department will review these design submittals. Any such request must acknowledge that the Design-Build Team is not expecting compensation for said design submittals, related meetings, or re-submittals until the first partial payment following the Financial Closing Date.

The Design-Build Team agrees, as evidenced by submission of the Technical Proposal and Price Proposal, to remain bound to all terms, conditions, requirements, and technical components of the RFP, the Technical Proposal, and Price Proposal until 120 days after the latest submission of the Price Proposal. In addition, if the Design-Build Team does not opt out of the Price Proposal adjustment afforded by the *Price Proposal Index Project Special Provision*, the Design-Build Team agrees, as evidenced by submission of the Technical Proposal and Price Proposal, to remain bound to all terms, conditions, requirements, and technical components of the RFP, the Technical Proposal, and the Price Proposal adjusted in accordance with the *Price Proposal Index Project Special Provision* until 270 days after the latest submission of the Price Proposal.

If necessary, this 270-day period may be extended if mutually agreeable by the NCTA and the Design-Build Team. Otherwise, the Design-Build Team may withdraw their Price Proposal in accordance with Article 103-4(A) of the Standard Specifications as amended by the Standard Special Provision entitled *Division One* contained elsewhere in this RFP. If the Design-Build Team elects to opt out of the *Price Proposal Index Project Special Provision*, this election does not affect the rights of the NCDOT and the Design-Build Team to implement a similar adjustment mechanism as part of a mutually agreeable extension of the aforementioned 270-day period.

Immediately following the Financial Closing Date, the NCTA intends to issue an Unlimited Notice to Proceed, thereby releasing the Design-Build Team to pursue all Work under the Contract, except as otherwise limited by environmental permits or lack thereof. If a delay in the Unlimited Notice to Proceed occurs solely due to the failure to provide full funding on or before June 1, 2019, contract time extension(s) will be granted for an additional calendar day for each day that the issuance of the Unlimited Notice to Proceed is delayed beyond July 1, 2019. The time extension will apply to the Substantial Completion Date and the Final Completion Date.

In the event that the Authority elects to proceed with a Best and Final Offer (BAFO), written notification of this election will be provided within 60 days of the opening of Price Proposals. Upon such written notification, the Department will release the surety from the obligations of the bid bond submitted with the original Price Proposal. However, a new bid bond conforming to the requirements of the Contract will be required with the Design-Build Team's Price Proposal, and if applicable their revised Technical Proposal, that is submitted to the Department in response to the Best and Final Offer Request for Proposals.

PRICE PROPOSAL INDEX

In the event that the issuance of the Unlimited Notice to Proceed is delayed beyond June 1, 2019, the Price Proposal (Total Lump Sum Amount Bid for the Entire Project) submitted by the Design-Build Team will be adjusted in accordance with this Project Special Provision.

The Design-Build Team may elect to opt out of the adjustment afforded by this provision. In such case, the Design-Build Team shall indicate their intention to forego this provision in their Technical Proposal. In such case, the Design-Build Team agrees, as evidenced by submission of the Technical Proposal and Price Proposal, to remain bound to all terms, conditions, requirements, and technical components of the RFP, the Technical Proposal, and the Price Proposal until 270 days after the latest submission of the Price Proposal.

The Total Lump Sum Amount Bid for the Entire Project will be adjusted based on the 20-City Construction Cost Index published in the Engineering New Record (e.g. Construction Cost Index of 11116.42 in July 2018). The index value reported in May 2019 will serve as the baseline index. The index value for the month in which the Unlimited Notice to Proceed is issued will then be compared to the baseline index value and the Total Amount Bid for the Entire Project will be adjusted upward or downward by the same percentage change from the baseline index value and the index value for the month in which the Unlimited Notice to Proceed is issued.

In the event the issuance of the Unlimited Notice to Proceed occurs between June 1, 2019 and June 1, 2020, the adjustment to the Total Amount Bid for the Entire Project is limited to a total 5% adjustment upward or downward.

In the unlikely event that the issuance of the Unlimited Notice to Proceed occurs after June 1, 2020, the adjustment to the Total Amount Bid for the Entire Project is limited to a percentage equal to 5% per annum, prorated by month (e.g. 7.5% cap for 18 month delay).

SUBSTANTIAL COMPLETION BONUS

Time is of the essence in completing the R-2721A project such that the extension of the Triangle Expressway from its current terminus at NC 55 Bypass to I-40 can be open to traffic. The NCTA desires that the work be completed and that the Design-Build Team pursue the work with such labor, equipment and materials, as necessary to ensure that the project is substantially completed on or before schedule.

Therefore, the Design-Build Team will receive an incentive payment for each calendar day (up to 180 days) that the project is substantially complete prior to the date specified in the Design-Build Team's Technical Proposal. The incentive payment will be graduated in accordance with the schedule below:

If the difference between the Substantial Completion Date Proposed in the Technical Proposal and the actual date the project is deemed to have achieved Substantial Completion is:	Then the incentive payment for each day of early Substantial Completion will be:	Provided, however that the aggregate incentive paid will not exceed:
1-28 days	\$2,000.00	\$56,000.00
29 days to 60 days	\$2,500.00	\$150,000.00
61 days to 180 days	\$3,000.00	\$540,000.00

The difference in calendar days between the Substantial Completion Date proposed in the Technical Proposal and the actual date the project is deemed to have achieved Substantial Completion shall be utilized in determining the incentive payment, except as noted herein. Contract time extensions that may be granted during the course of the project will have no bearing whatsoever on the method of calculating the incentive payment with the two following exceptions.

- (1) If the Unlimited Notice to Proceed is delayed due to a delayed Financial Closing Date as noted in the Project Special Provision *Proposal Validity Period*, the Substantial Completion Date for the purposes of the bonus noted herein will be adjusted in accordance with the Standard Special Provision entitled *Division One* contained elsewhere in this RFP.
- (2) In the event that the Design-Build Team can demonstrate that one or more of the following causes of delay impacts the critical path and therefore the date that Substantial Completion is achieved, the Substantial Completion Date proposed in the Technical Proposal, as modified in writing by the NCTA, will be compared to the actual date of Substantial Completion to calculate the incentive payment, except that the incentive payment will be 50% of the amount stipulated in the table above.
 - a. Discovery and resolution related to any previously unidentified archaeological or historic site;
 - b. Delay caused by the Toll Systems Integrator;
 - c. Delay caused by utility relocations, provided the Design-Build Team has demonstrated due diligence in the utility coordination efforts

INTERMEDIATE CONTRACT TIME #1 AND LIQUIDATED DAMAGES

Intermediate Contract Time #1 is established to ensure that the Toll System Integrator has adequate time to complete their work by the Substantial Completion Date for this Contract. Intermediate Contract Time #1 applies to the completion of all work required by the *All Electronic Tolling Toll Zone Infrastructure* Scope of Work, including all mainline pavement work within the limits specified in Section 5.2 of the aforementioned Scope of Work. Intermediate Contract Time #1 also includes all work necessary to design, fabricate, install, and erect on the entire project the conduit, fiber optic cable, ITS devices/infrastructure, and other items as depicted in the *ITS* Scope of Work and any other scopes of work sufficient to allow installation and testing of toll technology by the Toll Integrator.

Liquidated Damages for Intermediate Contract Time #1 for completion of all work required by the *All Electronic Tolling Toll Zone Infrastructure* Scope of Work and the other work items specified in this Project Special Provision are Fifteen Thousand Dollars (\$15,000.00) per calendar day.

The Completion Date for this Intermediate Contract Time #1 is 120 calendar days prior to the Substantial Completion Date.

OTHER LIQUIDATED DAMAGES

(3-17-08)

DB1 G11

Refer to the *Transportation Management* Scope of Work for more information on Intermediate Contract Times #2 through #6 regarding lane and road closure restrictions.

Refer to the *ITS* Scope of Work for more information on Intermediate Contract Times #7 through #9 regarding damage or disruption to fiber optic communication.

Refer to the *Erosion and Sedimentation Control* Scope of Work for additional information regarding liquidated damages due to non-compliance with Erosion and Sedimentation Control requirements.

PROJECT SCHEDULE

A cost-loaded Critical Path Method Schedule (CPM) is required for this project.

Twelve months prior to the Substantial Completion Date proposed in the Technical Proposal, the Design-Build Team shall submit a letter summarizing their anticipation of (1) when the various toll zones will be ready for the Toll System Integrator to begin work and (2) when the project will be Substantially Complete. This updated letter should be submitted with the Project Schedule each month thereafter.

In addition to weekly or bi-weekly design coordination, right of way coordination, construction progress, and safety meetings, the Design-Build Team shall meet with the NCTA each month to provide a synopsis of the CPM Schedule.

Reference Article 108-2 of the Standard Special Provision entitled *Division One* found elsewhere in this RFP.

PAYOUT SCHEDULE

(11-16-09)

DB1 G13

No later than 12:00 o'clock noon on the sixth day after the opening of the Price Proposal, the responsive proposer with the lowest adjusted price shall submit a proposed Anticipated Monthly Payout Schedule to the office of the State Contract Officer. The information shall be submitted in a sealed package with the outer wrapping clearly marked "Anticipated Monthly Payout Schedule" along with the Design-Build Team name and the contract number. The Anticipated Monthly Payout Schedule will be used by the Department to establish the monthly funding levels for this project. The Anticipated Monthly Payout Schedule shall parallel, and agree with, the project

schedule the Design-Build Team submits as a part of their Technical Proposal. The schedule shall include a monthly percentage breakdown (in terms of the total contract amount percentages) of the work anticipated to be completed. The schedule shall begin with the Date of Availability and end with the actual Completion Date proposed by the Design-Build Team. If the Payout Schedule is not submitted as stated herein, the Technical and Price Proposals will be considered irregular by the Department, and the bid may be rejected.

Submit updates of the Anticipated Monthly Payout Schedule on March 15, June 15, September 15, and December 15 of each calendar year until project acceptance. Submit all updates to the Resident Engineer with a copy to the NCTA Chief Engineer and the NCDOT State Construction Engineer.

MOBILIZATION

(8-28-17)

DB1 G15B

Revise the 2018 *Standard Specifications for Roads and Structures* as follows:

Page 8-1, Subarticle 800-2, MEASUREMENT AND PAYMENT

Delete this subarticle in its entirety and replace with the following:

800-2 MEASUREMENT AND PAYMENT

Six percent of the “Total Amount of Bid for Entire Project” shall be considered the lump sum amount for Mobilization. Partial payments for Mobilization will be made beginning with the first partial pay estimate paid on the Contract. The first payment will be made at a rate of 30 percent of the lump sum amount calculated for Mobilization. The second payment will occur with the first partial pay estimate paid following the issuance of the Unlimited Notice to Proceed. The second payment will be made at the rate of 30 percent of the lump sum amount calculated for Mobilization. The remaining 40 percent will be paid with the second partial pay estimate following the issuance of the Unlimited Notice to Proceed.

SUBSTANTIAL COMPLETION

(3-22-07)

DB1 G16

The Project will have reached Substantial Completion when all of the following requirements are satisfied:

1. Through traffic can be placed along the Project or along the work so that all lanes and shoulders are open such that traffic can move unimpeded at the posted speed. Intersecting roads and service roads are complete to the extent that they provide the safe and convenient use of the facility by the public;
2. The final layers of pavement for all lanes and shoulders along the mainline and ramps and loops are complete;
3. All signs for the purposes of safe travel, enforcement of any applicable laws, and guidance of the public are complete and accepted, including any required for toll collection purposes;

4. All noise walls, guardrails, drainage devices, ditches, excavation and embankment are complete;
5. Remaining work along the project consists of incidental construction that is away from the paved portion of the roadway;
6. Except as needed for punch list items identified after Substantial Completion and Corrective Work identified after Substantial Completion, no subsequent lane closures or slow moving operations are required on the mainline; and
7. A satisfactory warranty bond is executed and provided to the NCTA. Reference the Project Special Provision *Three-Year Guarantee*.

Upon apparent substantial completion of the Project, the Design-Build Team will perform an in-depth self-inspection to ensure that the Project meets the conditions of Substantial Completion as defined herein. Upon written recommendation from the Design-Build Team, the Engineer will perform a subsequent inspection. The results of the Engineer's inspection will be shared with the Design-Build Team in writing within two weeks of receipt of the Design-Build Teams' written recommendation, and the Design-Build Team will be advised as to whether or not the Engineer has determined Substantial Completion to have been met. Substantial Completion will not have occurred until all of the recommendations made, if any, at the time of the Engineer's inspection have been satisfactorily met.

The Design-Build Team may submit a plan for advanced inspection of certain areas or work to facilitate the efficient determination of Substantial Completion.

SUBMITTAL OF QUANTITIES, FUEL BASE INDEX PRICE AND OPT-OUT OPTION

1/23/14

DB1 G43

(A) Submittal of Quantities

Submit quantities on the *Fuel Usage Factor Chart and Estimate of Quantities* sheet, located in the back of this RFP, following the Itemized Proposal Sheet.

The Design-Build Team shall prepare an Estimate of Quantities that they anticipate incorporating into the completed project and upon which the Price Proposal will be based. The quantity breakdown shall include all items of work that appear in the *Fuel Usage Factor Chart and Estimate of Quantities* sheet. Only those items of work which are specifically noted in the *Fuel Usage Factor Chart and Estimate of Quantities* sheet will be subject to fuel price adjustments.

Submittal The submittal shall be signed and dated by an officer of the Design-Build Team. The information shall be copied and submitted in a separate sealed package with the outer wrapping clearly marked "Fuel Price Adjustment" and shall be delivered at the same time and location as the Technical Proposal. The original shall be submitted in the Price Proposal.

Trade Secret Information submitted on the *Fuel Usage Factor Chart and Estimate of Quantities* sheet will be considered “Trade Secret” in accordance with the requirements of G.S. 66-152(3) until such time as the Price Proposal is opened.

(B) Base Index Price

The Design-Build Team’s Estimate of Quantities will be used on the various partial payment estimates to determine fuel price adjustments. The Design-Build Team shall submit a payment request for quantities of work completed based on the work completed for that estimate period. The quantities requested for partial payment shall be reflective of the work actually accomplished for the specified period. The Design-Build Team shall certify that the quantities are reasonable for the specified period. The base index price for DIESEL #2 FUEL is \$~~_____~~1.8075 per gallon.

(C) Opt Out of Fuel Price Adjustment

If the Design-Build Team elects not to pursue reimbursement for Fuel Price Adjustments, a quantity of zero shall be entered for all quantities in the *Fuel Usage Factor Chart and Estimate of Quantities* sheet and the declination box shall be checked. Failure to complete this form will mean that the Design-Build Team is declining the Fuel Price Adjustments for this project.

(D) Change Option

The proposer will not be permitted to change the option after the copy of the *Fuel Usage Factor Chart and Estimate of Quantities* sheet is submitted.

(E) Failure to Submit

Failure to submit the completed *Fuel Usage Factor Chart and Estimate of Quantities* sheet separately with the Technical Proposal and in the Price Proposal will result in the Technical and Price Proposal being considered irregular by the Department and the Technical and Price Proposal may be rejected.

INDIVIDUAL MEETINGS WITH PROPOSERS

(9-1-11)

DB1 G048

The NCTA will provide at least two Question and Answer Sessions to meet with each proposer individually to specifically address questions regarding the draft Requests for Proposals.

After issuance of the First Industry Draft RFP, the NCTA will invite one or two representatives from each Design-Build Team to attend regular utility coordination meetings arranged by the Department.

The NCTA will afford each proposer two additional meetings with the NCTA (maximum two-hour time limit per each meeting) to discuss project specifics and address the proposer’s concerns and questions. These meetings may occur at any time after the first Question and Answer Session with the proposers and no later than two weeks prior to the Technical Proposal submittal date. The

proposer shall request these meetings in writing to the NCTA Chief Engineer, providing the NCTA a minimum of one week advance notice of the requested date. The proposer shall also state in the request those disciplines within the Department that are requested to be in attendance. The NCTA makes no assurance that the request may be honored on that specific date or that all disciplines requested can be in attendance.

Additional individual meetings may be permitted in accordance with the *Alternative Technical Concepts and Confidential Questions* Project Special Provision found elsewhere in this RFP.

**EXECUTION OF BID, NON-COLLUSION AFFIDAVIT, DEBARMENT
CERTIFICATION AND GIFT BAN CERTIFICATION**

(1/24/13)

DB1 G52

The Proposer's attention is directed to the various sheets in the Request for Proposals which are to be signed by the Proposer. A list of these sheets is shown below. The signature sheets are located behind the Itemized Proposal Sheet in this Request for Proposal. The NCDOT bid bond form is available on-line at:

<https://connect.ncdot.gov/letting/Pages/Design-Build-Resources.aspx>

or by contacting the Records and Documents office at 919-707-6900.

1. Applicable Signature Sheets: 1, 2, 3, 4, 5, or 6 (Bid)
2. Bid Bond dated the day of the Price Proposal submission

The Proposer shall certify to the best of his knowledge all subcontractors, material suppliers and vendors utilized herein current status concerning suspension, debarment, voluntary exclusion, or determination of ineligibility by any federal agency, in accordance with the "Debarment Certification" located behind the *Execution of Bid Non-Collusion Affidavit, Debarment Certification and Gift Ban Certification* signature sheets in this RFP. Execution of the bid signature sheets in conjunction with any applicable statements concerning exceptions, when such statements have been made on the "Debarment Certification", constitutes the Proposer's certification of "status" under penalty of perjury under the laws of the United States.

SUBMISSION OF DESIGN-BUILD PROPOSAL

(9-1-11) (Rev. 8-30-17)

DB1 G55A

The Proposer's attention is directed that each Proposer's Design-Build Proposal shall comply with the following requirements in order for that Design-Build Proposal to be responsive and considered for award.

1. The Proposer shall be prequalified with the Department prior to submitting a Design-Build Proposal.
2. The Proposer shall deliver the Technical Proposal and the Price Proposal to the place indicated, and prior to the times indicated in this Request for Proposals.

3. The Price Proposal documents shall be signed by an authorized employee of the Proposer.
4. The Price Proposal shall be accompanied by Bid surety in the form of a Bid Bond or Bid Deposit, dated the day of Price Proposal submission.
5. The Proposer shall complete the form Listing of DBE Subcontractors contained elsewhere in this RFP in accordance with the *Disadvantaged Business Enterprises* Project Special Provision found elsewhere in this RFP.
6. The Design-Build Proposal shall address all the requirements as specified in this Request for Proposals.

In addition to the above requirements, failure to comply with any of the requirements of Article 102-8 of the Standard Special Provisions, *Division One* (found elsewhere in this RFP), Article 102-9 of the 2018 *Standard Specifications for Roads and Structures*, or Article 102-10 of the 2018 *Standard Specifications for Roads and Structures* and as amended in the Standard Special Provisions, *Division One* (found elsewhere in this RFP) may result in a Design-Build Proposal being rejected.

ALTERNATIVE TECHNICAL CONCEPTS AND CONFIDENTIAL QUESTIONS

(6-8-11) (Rev. 7-20-17)

DB1 G56A

To accommodate innovation that may or may not be specifically allowed by the RFP, or other documents incorporated into the contract by reference, the Design-Build Team has the option of submitting Confidential Questions and Alternative Technical Concepts.

Definitions

A Confidential Question is defined as a private query to the NCTA containing information whose disclosure could alert others to certain details of doing business in a particular manner.

An Alternative Technical Concept is a private query to the NCTA that requests a variance to the requirements of the RFP, or other documents incorporated into the contract by reference, that is equal or better in quality or effect, as determined by the NCTA in its sole discretion, and that have been used elsewhere under comparable circumstances.

Confidential Questions

The Design-Build Team will be permitted to ask Confidential Questions of the NCTA, and neither the question nor the answer will be shared with other Design-Build Teams. The Department, in its sole discretion, will determine if a question is considered confidential.

Confidential Questions arising prior to issuance of the Final RFP will be allowed during the industry review of the draft RFP with the individual Design-Build Teams. The NCTA will answer the Confidential Question verbally at the industry review meeting, if possible, and / or through subtle changes in the Final RFP, which will clarify the scope by either allowing or disallowing the request. To the greatest extent possible, the revision will be made in such a manner as to not disclose the Confidential Question.

After the issuance of the Final RFP, Confidential Questions may be asked by requesting a meeting with the NCTA Chief Engineer. The request shall be in writing and provide sufficient detail to evaluate the magnitude of the request. Questions shall be of such magnitude as to warrant a special meeting. Minor questions will not be acknowledged or answered. After evaluation, the NCTA Chief Engineer will respond to the question in writing to the Design-Build Team and / or through subtle changes in the Final RFP as reflected in an addendum, which will clarify the scope by either allowing or disallowing the request. To the greatest extent possible, the revision will be made in such a manner as to not disclose the Confidential Question.

If the Design-Build Team includes work based on the Confidential Questions and answers, the work shall be discussed in the Technical Proposal.

Alternative Technical Concepts

The Design-Build Team will be allowed to submit an unlimited number of Alternative Technical Concepts; however, in an effort to minimize the workload of both the NCTA and the Design-Build Teams, the Design-Build Team is encouraged to utilize the Question and Answer Sessions and additional Individual Meetings to discuss potential ATCs prior to their submittal.

Preliminary ATCs may be submitted at any time following the issuance of the first Industry Draft and prior to 6 weeks prior to the deadline for submitting the Technical Proposal. Formal ATCs may be submitted at any time following the issuance of the first Industry Draft and prior to 4 weeks prior to the deadline for submitting the Technical Proposal. Additional information requested by the NCTA, including a Formal ATC submitted following a favorable response on a Preliminary ATC, shall be submitted no later than 3 weeks prior to the deadline for submitting Technical Proposal, unless otherwise permitted in writing by the NCTA Chief Engineer.

The Design-Build Team may include an ATC in the Technical and Price Proposal only if the ATC has been received by the NCTA in accordance with the requirements above and it has been approved by the NCTA (including conditionally approved ATCs, if all conditions are met).

The Design-Build Team shall be solely responsible for reviewing all versions of the RFP, including all Addenda, and determining variances required by a Formal ATC. The Design-Build Team is cautioned that the NCTA's approval in no way implies that the Design-Build Team has requested approval of all the required variances to the RFP requirements. Additionally, should the NCTA revise the RFP after a Formal ATC has been approved, the Design-Build Team shall be solely responsible for reviewing the RFP and determining if the ATC deviates from the revised requirements. If necessary, the Design-Build Team must submit a request for approval of all additional required variance(s) no later than two weeks prior to the deadline for submitting the Technical Proposal.

An ATC shall in no way take advantage of an error or omission in the RFP, or other documents incorporated into the contract by reference. If, at the sole discretion of the NCTA, an ATC is deemed to take advantage of an error or omission in the RFP, or other documents incorporated into the contract by reference, the RFP will be revised without regard to confidentiality. If at any time, the NCTA receives a documented question on the project similar to a concept submitted in

the form of a Preliminary ATC or Formal ATC, the NCTA reserves the right to revise the RFP without further regard for confidentiality.

For ATCs that contain multiple concepts or variations to the same concept, the NCTA may require that the Design-Build Team re-submit multiple ATCs or review and respond to all concepts or variations contained in the ATC.

By approving an ATC, the NCTA acknowledges that the ATC may be included in the design and RFC Plans; however, approval of any ATC in no way relieves the Design-Build Team of its obligation to satisfy (1) other contract requirements not specifically identified in the ATC submittal; (2) any obligation that may arise under applicable laws and regulations; and (3) any obligation mandated by the regulatory agencies as a permit condition.

ATC Submittals

Each ATC submittal shall include three individually bound hard copies and an electronic .pdf file of the entire submittal and shall be submitted to the NCTA Chief Engineer. Excluding the ATC distribution letter and supporting information that is provided as an attachment, the ATC shall not include any reference to the submitter's identity.

Formal ATCs

Each Formal ATC submittal shall include the following information:

- 1) **Description** - A detailed description and schematic drawings of the configuration of the ATC or other appropriate descriptive information (including, if appropriate, product details [i.e., specifications, construction tolerances, special provisions] and a traffic operational analysis, if appropriate);
- 2) **Usage** - Where and how the ATC would be used on the project;
- 3) **Deviations** - References to all RFP requirements, or other documents incorporated into the contract by reference, that are inconsistent with the proposed ATC, an explanation of the nature of the deviations from said requirements, and a request for approval of such variance(s);
- 4) **Analysis** - An analysis justifying use of the ATC and why the variance to the RFP requirements, or other documents incorporated into the contract by reference, should be allowed;
- 5) **Impacts** - Discussion of potential impacts on vehicular traffic, environmental impacts identified, community impact, safety and life-cycle project impacts, and infrastructure costs (including impacts on the cost of repair and maintenance);
- 6) **History** - A detailed description of other projects where the ATC has been used, the success of such usage, and names and telephone numbers of project owners that can confirm such statements;
- 7) **Risks** - A description of added risks to the Department, NCTA, and other entities associated with implementing the ATC; and

- 8) **Costs** - An estimate of the ATC implementation costs to the NCTA, the Design-Build Team, and other entities (right of way, utilities, mitigation, long term maintenance, etc.).

The Formal ATC, if approved, shall be included in the Price Proposal if the Design-Build Team elects to include it in their Technical Proposal.

Review of ATCs

A panel will be selected to review each ATC, which may or may not include members of the Technical Review Committee. The Design-Build Team shall make no direct contact with any member of the review panel, except as may be permitted by the NCTA Chief Engineer. Unapproved contact with any member of the review panel will result in a disqualification of that ATC.

The NCTA may request additional information regarding a proposed ATC at any time. To the greatest extent possible, the NCTA will return responses to, or request additional information from, the Design-Build Team within 15 business days of the original submittal of a Formal ATC. If additional information is requested, the NCTA will provide a response within five business days of receipt of all requested information.

The NCTA may conduct confidential one-on-one meeting(s) to discuss the Design-Build Team's ATC. Under no circumstances will the Department or NCTA be responsible or liable to the Design-Build Team or any other party as a result of disclosing any ATC materials, whether the disclosure is deemed required by law, by a court order, or occurs through inadvertence, mistake or negligence on the part of the Department or NCTA or their respective officers, employees, contractors, or consultants.

In the event that the NCTA receives ATCs from more than one Design-Build Team that are deemed by the NCTA, in its sole discretion, to be similar in nature, the NCTA reserves the right to modify the RFP without further regard for confidentiality.

NCTA Response to Formal ATCs

The NCTA will review each Formal ATC and will respond to the Design-Build Team with one of the following determinations:

- 1) The ATC is approved.
- 2) The ATC is not approved.
- 3) The ATC is not approved in its present form, but may be approved upon satisfaction, in the NCTA's sole discretion, of certain identified conditions that shall be met or certain clarifications or modifications that shall be made (conditionally approved).
- 4) The submittal does not qualify as an ATC but may be included in the Design-Build Proposal without an ATC (i.e., the concept complies with the baseline requirements of the RFP).

- 5) The submittal does not qualify as an ATC and may not be included in the Design-Build Proposal.
- 6) The ATC is deemed to take advantage of an error or omission in the RFP, or other documents incorporated into the contract by reference, in which case the ATC will not be considered, and the RFP will be revised to correct the error or omission.
- 7) A documented question has been received outside of the ATC process on the same topic and the RFP will be revised to address that question.
- 8) More than one ATC has been received on the same topic and the NCTA has elected to exercise its right to revise the RFP. This response could also follow and supersede one of the other previously supplied responses above.
- 9) The ATC contains multiple concepts and has not been considered. Should the Design-Build Team wish to pursue one or more of the concepts presented in the ATC, a submittal for each individual concept will be required.

Formal ATC Inclusion in Technical Proposal

The Design-Build Team may incorporate one or more approved Formal ATCs as part of its Technical and Price Proposals. If the NCTA responded to a Formal ATC by stating that it would be approved if certain conditions were met, those conditions shall be stipulated and met in the Technical Proposal.

In addition to outlining each implemented Formal ATC, and providing assurances to meet all attached conditions, the Design-Build Team shall also include a copy of the Formal ATC approval letter from the NCTA Chief Engineer in each of the twelve Technical Proposals submitted. This letter will be included in the distribution of the Technical Proposals to the Technical Review Committee.

Approval of a Formal ATC in no way implies that the Formal ATC will receive a favorable review from the Technical Review Committee. The Technical Proposals will be evaluated in regards to the evaluation criteria found in this RFP, regardless of whether or not Formal ATCs are included.

The Price Proposal shall reflect all incorporated Formal ATCs. Except for incorporating approved Formal ATCs, the Technical Proposal may not otherwise contain exceptions to, or deviations from, the requirements of the RFP, or other documents incorporated into the contract by reference.

Preliminary ATCs

At the Design-Build Team's option, a Preliminary ATC submittal may be made that presents a concept and a brief narrative of the benefits of said concept. The purpose of allowing such a Preliminary ATC is to limit the Design-Build Team's expense in the pursuit of a Formal ATC that may be quickly denied by the NCTA.

To the greatest extent possible, the NCTA will review Preliminary ATCs within ten business days of submittal and provide written comments that include one of the responses noted below. The

NCTA's response to a Preliminary ATC submittal will be one of the following or a variation thereof:

- 1) The Preliminary ATC is denied;
- 2) The Preliminary ATC would be considered as a Formal ATC if the Design-Build Team so elects to pursue a Formal ATC submission;
- 3) An ATC is not required;
- 4) A documented question has been received outside of the ATC process on the same topic and the RFP will be revised to address that question;
- 5) More than one ATC has been received on the same topic and the NCTA has elected to exercise its right to revise the RFP;
- 6) The ATC takes advantage of an error or omission in the RFP or other documents incorporated into the contract by reference, in which case the ATC will not be considered and the RFP will be revised to correct the error or omission; or
- 7) The ATC contains multiple concepts and has not been considered, in which case an ATC for each individual concept will be required.

The NCTA in no way warrants that a favorable response to a Preliminary ATC submittal will translate into a favorable response to a Formal ATC submittal. Likewise, a favorable response to a Preliminary ATC submittal is not sufficient to include the ATC in a Technical Proposal.

SCHEDULE OF ESTIMATED COMPLETION PROGRESS

(07-15-08)

DB1 G58

The Design-Build Team's attention is directed to the Standard Special Provision entitled *Availability of Funds - Termination of Contracts* included elsewhere in this RFP. The Department of Transportation's schedule of estimated completion progress for this project as required by that Standard Special Provision is as follows:

<u>Fiscal Year</u>	<u>Progress (Dollar Value)</u>
2019 (07/01/18 – 06/30/19)	1% of Total Amount Bid
2020 (07/01/19 – 06/30/20)	36% of Total Amount Bid
2021 (07/01/20 – 06/30/21)	28% of Total Amount Bid
2022 (07/01/21 – 06/30/22)	20% of Total Amount Bid
2023 (07/01/22 – 06/30/23)	12% of Total Amount Bid
2024 (07/01/23 – 06/30/24)	3% of Total Amount Bid

The NCTA does not intend to limit progress based on the above schedule of estimated progress unless required to do so by the North Carolina General Assembly or the trustee of the project funds.

The Design-Build Team shall also furnish its own CPM schedule in accordance with Article 108-2 of the Standard Special Provision entitled *Division One* contained elsewhere in the RFP. Any acceleration of the progress as shown by the Design-Build Team's CPM schedule over the progress as shown above shall be subject to the approval of NCTA.

DISADVANTAGED BUSINESS ENTERPRISE

(10-16-07) (Rev. 11-28-18)

102-15(J)

SP1 G61

DB1 G061

Description

The purpose of this Special Provision is to carry out the U.S. Department of Transportation's policy of ensuring nondiscrimination in the award and administration of contracts financed in whole or in part with Federal funds. This provision is guided by 49 CFR Part 26.

Definitions

Additional DBE Subcontractors - Any DBE submitted at the time of bid that will not be used to meet the DBE goal. No submittal of a Letter of Intent is required.

Committed DBE Subcontractor - Any DBE submitted at the time of bid that is being used to meet the DBE goal by submission of a Letter of Intent. Or any DBE used as a replacement for a previously committed DBE firm.

Contract Goal Requirement - The approved DBE participation at time of award, but not greater than the advertised contract goal.

DBE Goal - A portion of the total contract, expressed as a percentage that is to be performed by committed DBE subcontractor(s).

Disadvantaged Business Enterprise (DBE) - A firm certified as a Disadvantaged Business Enterprise through the North Carolina Unified Certification Program.

Goal Confirmation Letter - Written documentation from the Department to the Proposer confirming the Design-Build Team's approved, committed DBE participation along with a listing of the committed DBE firms.

Manufacturer - A firm that operates or maintains a factory or establishment that produces on the premises, the materials or supplies obtained by the Design-Build Team.

Regular Dealer - A firm that owns, operates, or maintains a store, warehouse, or other establishment in which the materials or supplies required for the performance of the contract are bought, kept in stock, and regularly sold to the public in the usual course of business. A regular dealer engages in, as its principal business and in its own name, the purchase and sale or lease of the products in question. A regular dealer in such bulk items as steel, cement, gravel, stone, and petroleum products need not keep such products in stock, if it owns and operates distribution equipment for the products. Brokers and packagers are not regarded as manufacturers or regular dealers within the meaning of this section.

Replacement / Substitution - A full or partial reduction in the amount of work subcontracted to a committed (or an approved substitute) DBE firm.

North Carolina Unified Certification Program (NCUCP) - A program that provides comprehensive services and information to applicants for DBE certification, such that an applicant

is required to apply only once for a DBE certification that will be honored by all recipients of USDOT funds in the state and not limited to the Department of Transportation only. The Certification Program is in accordance with 49 CFR Part 26.

United States Department of Transportation (USDOT) - Federal agency responsible for issuing regulations (49 CFR Part 26) and official guidance for the DBE program.

Forms and Websites Referenced in this Provision

DBE Payment Tracking System - On-line system in which the Design-Build Team enters the payments made to DBE subcontractors who have performed work on the project.

<https://apps.dot.state.nc.us/Vendor/PaymentTracking/>

DBE-IS Subcontractor Payment Information - Form for reporting the payments made to all DBE firms working on the project.

<https://connect.ncdot.gov/business/Turnpike/Documents/Form%20DBE-IS%20Subcontractor%20Payment%20Information.pdf>

RF-1 DBE Replacement Request Form - Form for replacing a committed DBE.

<http://connect.ncdot.gov/projects/construction/Construction%20Forms/DBE%20MBE%20WBE%20Replacement%20Request%20Form.pdf>

SAF Subcontract Approval Form - Form required for approval to sublet the contract.

<http://connect.ncdot.gov/projects/construction/Construction%20Forms/Subcontract%20Approval%20Form%20Rev.%202012.zip>

JC-1 Joint Check Notification Form - Form and procedures for joint check notification. The form acts as a written joint check agreement among the parties providing full and prompt disclosure of the expected use of joint checks.

<http://connect.ncdot.gov/projects/construction/Construction%20Forms/Joint%20Check%20Notification%20Form.pdf>

Letter of Intent - Form signed by the Contractor and the DBE subcontractor, manufacturer or regular dealer that affirms that a portion of said contract is going to be performed by the signed DBE for the amount listed at the time of bid.

<http://connect.ncdot.gov/letting/LetCentral/Letter%20of%20Intent%20to%20Perform%20as%20a%20Subcontractor.pdf>

Listing of DBE Subcontractors Form - Form for entering DBE subcontractors on a project that will meet this DBE goal contained elsewhere in this RFP.

<http://connect.ncdot.gov/municipalities/Pages/Bid-Proposals-for-LGA.aspx>

Subcontractor Quote Comparison Sheet - Spreadsheet for showing all subcontractor quotes in the work areas where DBEs quoted on the project. This sheet is submitted with good faith effort packages.

<http://connect.ncdot.gov/business/SmallBusiness/Documents/DBE%20Subcontractor%20Quote%20Comparison%20Example.xls>

DBE Goal

The following DBE goal for participation by Disadvantaged Business Enterprises is established for this contract:

Disadvantaged Business Enterprises **12.0%**

- (A) *If the DBE goal is more than zero*, the Design-Build Team shall exercise all necessary and reasonable steps to ensure that DBEs participate in at least the percent of the contract as set forth above as the DBE goal.
- (B) *If the DBE goal is zero*, the Design-Build Team shall make an effort to recruit and use DBEs during the performance of the contract. Any DBE participation obtained shall be reported to the Department.

This goal is to be met through utilization of highway construction contractors and / or right of way acquisition firms. Utilization of DBE firms performing design, other preconstruction services, or Construction Engineering and Inspection are not included in this goal.

Directory of Transportation Firms (Directory)

Real-time information is available about firms doing business with the Department and firms that are certified through NCUCP in the Directory of Transportation Firms. Only firms identified in the Directory as DBE certified shall be used to meet the DBE goal. The Directory can be found at the following link.

<https://www.ebs.nc.gov/VendorDirectory/search.html?s=fn&a=new>

The listing of an individual firm in the directory shall not be construed as an endorsement of the firm's capability to perform certain work.

Listing of DBE Subcontractors

At the time of bid, Proposers shall submit all DBE participation that they anticipate to use during the life of the contract. Only those identified to meet the DBE goal will be considered committed, even though the listing shall include both committed DBE subcontractors and additional DBE subcontractors. Additional DBE subcontractor participation submitted at the time of bid will be used toward the Department's overall race-neutral goal. Only those firms with current DBE certification at the time of Price Proposal opening will be acceptable for listing in the Proposer's

submittal of DBE participation. The Design-Build Team shall indicate the following required information:

- (1) *If the DBE goal is more than zero,*
 - (a) Proposers, at the time the Price Proposal is submitted, shall submit a listing of *DBE* participation, including the names and addresses on *Listing of DBE Subcontractors* contained elsewhere in the contract documents in order for the Price Proposal to be considered responsive. Proposers shall indicate the total dollar value of the DBE participation for the contract.
 - (b) If Proposers have no DBE participation, they shall indicate this on the *Listing of DBE Subcontractors* by entering the word “None” or the number “0.” This form shall be completed in its entirety. **Blank forms will not be deemed to represent zero participation.** Price Proposals submitted that do not have DBE participation indicated on the appropriate form will not be read publicly during the opening of the Price Proposals. The Department will not consider these Price Proposals for award and the proposal will be rejected.
 - (c) The Proposer shall be responsible for ensuring that the DBE is certified at the time of bid by checking the Directory of Transportation Firms. If the firm is not certified at the time of the opening of the Price Proposals, that DBE’s participation will not count towards achieving the corresponding goal.
- (2) *If the DBE goal is zero,* entries on the *Listing of DBE Subcontractors* are not required for the zero goal, however any DBE participation that is achieved during the project shall be reported in accordance with requirements contained elsewhere in this special provision.

DBE Prime Contractor

When a certified DBE firm proposes on a contract that contains a DBE goal, the DBE firm is responsible for meeting the goal or making good faith efforts to meet the goal, just like any other proposer. In most cases, a DBE proposer on a contract will meet the DBE goal by virtue of the work it performs on the contract with its own forces. However, all the work that is performed by the DBE proposer and any other DBE subcontractors will count toward the DBE goal. The DBE proposer shall list itself along with any DBE subcontractors, if any, in order to receive credit toward the DBE goal.

For example, if the DBE goal is 45.0% and the DBE proposer will only perform 40.0% of the contract work, the prime will list itself at 40.0%, and the additional 5.0% shall be obtained through additional DBE participation with DBE subcontractors or documented through a good faith effort.

DBE prime contractors shall also follow Sections A and B listed under *Listing of DBE Subcontractor* just as a non-DBE proposer would.

Written Documentation – Letter of Intent

The Proposer shall submit written documentation for each DBE that will be used to meet the DBE goal of the contract, indicating the Proposer's commitment to use the DBE in the contract. This documentation shall be submitted on the Department's form titled *Letter of Intent*.

The documentation shall be received in the office of the State Contractor Utilization Engineer or at DBE@ncdot.gov no later than 10:00 a.m. on the sixth calendar day following opening of Price Proposals, unless the sixth day falls on an official state holiday. In that situation, it is due in the office of the State Contractor Utilization Engineer no later than 10:00 a.m. on the next official state business day.

If the Proposer fails to submit the Letter of Intent from each committed DBE to be used toward the DBE goal, or if the form is incomplete (i.e. both signatures are not present), the DBE participation will not count toward meeting the DBE goal. If the lack of this participation drops the commitment below the DBE goal, the Design-Build Team shall submit evidence of good faith efforts, completed in its entirety, to the State Contractor Utilization Engineer or DBE@ncdot.gov no later than 10:00 a.m. on the eighth calendar day following opening of the Price Proposals, unless the eighth day falls on an official state holiday. In that situation, it is due in the office of the State Contractor Utilization Engineer no later than 10:00 a.m. on the next official state business day.

Submission of Good Faith Effort

If the Proposer fails to meet or exceed the DBE goal the Proposer with the apparent adjusted low price shall submit to the Department documentation of adequate good faith efforts made to reach the DBE goal.

A hard copy and an electronic copy of this information shall be received in the office of the State Contractor Utilization Engineer or at DBE@ncdot.gov no later than 10:00 a.m. on the sixth calendar day following opening of the Price Proposals unless the sixth day falls on an official state holiday. In that situation, it is due in the office of the State Contractor Utilization Engineer no later than 10:00 a.m. on the next official state business day. If the Design-Build Team cannot send the information electronically, then one complete set and nine copies of this information shall be received under the same time constraints above.

Note: Where the information submitted includes repetitious solicitation letters, it will be acceptable to submit a representative letter along with a distribution list of the firms that were solicited. Documentation of DBE quotations shall be a part of the good faith effort submittal. This documentation may include written subcontractor quotations, telephone log notations of verbal quotations, or other types of quotation documentation.

Consideration of Good Faith Effort for Projects with DBE Goals More Than Zero

Adequate good faith efforts mean that the Proposer took all necessary and reasonable steps to achieve the goal which, by their scope, intensity, and appropriateness, could reasonably be expected to obtain sufficient DBE participation. Adequate good faith efforts also mean that the

Proposer actively and aggressively sought DBE participation. Mere *pro forma* efforts are not considered good faith efforts.

The Department will consider the quality, quantity, and intensity of the different kinds of efforts a Proposer has made. Listed below are examples of the types of actions a proposer will take in making a good faith effort to meet the goal and are not intended to be exclusive or exhaustive, nor is it intended to be a mandatory checklist.

- (A) Soliciting through all reasonable and available means (e.g. attendance at pre-bid meetings, advertising, written notices, use of verifiable electronic means through the use of the NCDOT Directory of Transportation Firms) the interest of all certified DBEs who have the capability to perform the work of the contract. The Proposer must solicit this interest within at least ten days prior to the opening of the Price Proposals to allow the DBEs to respond to the solicitation. Solicitation shall provide the opportunity to DBEs within the Division and surrounding Divisions where the project is located. The Proposer must determine with certainty if the DBEs are interested by taking appropriate steps to follow up initial solicitations.
- (B) Selecting portions of the work to be performed by DBEs in order to increase the likelihood that the DBE goals will be achieved. Where appropriate, break out contract work items into economically feasible units to facilitate DBE participation, even when the prime contractor might otherwise prefer to perform these work items with its own forces. Negotiate with subcontractors to assume part of the responsibility to meet the contract DBE goal when the work to be sublet includes potential for DBE participation (2nd and 3rd tier subcontractors).
- (C) Providing interested DBEs with adequate information about the plans, specifications, and requirements of the contract in a timely manner to assist them in responding to a solicitation.
- (D)
 - (1) Negotiating in good faith with interested DBEs. It is the Proposer's responsibility to make a portion of the work available to DBE subcontractors and suppliers and to select those portions of the work or material needs consistent with the available DBE subcontractors and suppliers, to facilitate DBE participation. Evidence of such negotiation includes the names, addresses, and telephone numbers of DBEs that were considered; a description of the information provided regarding the plans and specifications for the work selected for subcontracting; and evidence as to why additional agreements could not be reached for DBEs to perform the work.
 - (2) A proposer using good business judgment would consider a number of factors in negotiating with subcontractors, including DBE subcontractors, and would take a firm's price and capabilities as well as contract goals into consideration. However, the fact that there may be some additional costs involved in finding and using DBEs is not in itself sufficient reason for a proposer's failure to meet the contract DBE goal, as long as such costs are reasonable. Also, the ability or desire of a prime contractor to perform the work of a contract with its own organization does not relieve the Proposer of the responsibility to make good faith efforts.

Proposing Design-Build Teams are not, however, required to accept higher quotes from DBEs if the price difference is excessive or unreasonable.

- (E) Not rejecting DBEs as being unqualified without sound reasons based on a thorough investigation of their capabilities. The Proposer's standing within its industry, membership in specific groups, organizations, or associates and political or social affiliations (for example, union vs. non-union employee status) are not legitimate causes for the rejection or non-solicitation of bids in the Proposer's efforts to meet the project goal.
- (F) Making efforts to assist interested DBEs in obtaining bonding, lines of credit, or insurance as required by the recipient or proposer.
- (G) Making efforts to assist interested DBEs in obtaining necessary equipment, supplies, materials, or related assistance or services.
- (H) Effectively using the services of available minority / women community organizations; minority / women contractors' groups; Federal, State, and local minority / women business assistance offices; and other organizations as allowed on a case-by-case basis to provide assistance in the recruitment and placement of DBEs. Contact within seven days from the Price Proposals opening the Business Opportunity and Work Force Development Unit at DBE@ncdot.gov to give notification of the Proposer's inability to get DBE quotes.
- (I) Any other evidence that the Proposer submits which shows that the Proposer has made reasonable good faith efforts to meet the DBE goal.

In addition, the Department may take into account the following:

- (1) Whether the Proposer's documentation reflects a clear and realistic plan for achieving the DBE goal.
- (2) The Proposer's past performance in meeting the DBE goals.
- (3) The performance of other proposers in meeting the DBE goal. For example, when the Proposer with the apparent adjusted low price fails to meet the DBE goal, but others meet it, you may reasonably raise the question of whether, with additional reasonable efforts the Proposer with the apparent adjusted low price could have met the goal. If the Proposer with the apparent adjusted low price fails to meet the DBE goal, but meets or exceeds the average DBE participation obtained by other proposers, the Department may view this, in conjunction with other factors, as evidence of the Proposer with the apparent adjusted low price having made a good faith effort.

If the Department does not award the contract to the Proposer with the apparent adjusted low price, the Department reserves the right to award the contract to the Proposer with the next adjusted lowest adjusted price that can satisfy to the Department that the DBE goal can be met or that an adequate good faith effort has been made to meet the DBE goal.

Non-Good Faith Appeal

The State Contractual Services Engineer will notify the Design-Build Team verbally and in writing of non-good faith. A Design-Build Team may appeal a determination of non-good faith made by the Goal Compliance Committee. If a Design-Build Team wishes to appeal the determination made by the Committee, they shall provide written notification to the State Contractual Services Engineer or at DBE@ncdot.gov. The appeal shall be made within two business days of notification of the determination of non-good faith.

Counting DBE Participation Toward Meeting DBE Goal

(A) Participation

The total dollar value of the participation by a committed DBE will be counted toward the contract goal requirement. The total dollar value of participation by a committed DBE will be based upon the value of work actually performed by the DBE and the actual payments to DBE firms by the Design-Build Team.

(B) Joint Checks

Prior notification of joint check use shall be required when counting DBE participation for services or purchases that involves the use of a joint check. Notification shall be through submission of Form JC-1 (*Joint Check Notification Form*) and the use of joint checks shall be in accordance with the Department's Joint Check Procedures.

(C) Subcontracts (Non-Trucking)

A DBE may enter into subcontracts. Work that a DBE subcontracts to another DBE firm may be counted toward the contract goal requirement. Work that a DBE subcontracts to a non-DBE firm does not count toward the contract goal requirement. If a DBE contractor or subcontractor subcontracts a significantly greater portion of the work of the contract than would be expected on the basis of standard industry practices, it shall be presumed that the DBE is not performing a commercially useful function. The DBE may present evidence to rebut this presumption to the Department. The Department's decision on the rebuttal of this presumption is subject to review by the Federal Highway Administration but is not administratively appealable to USDOT.

(D) Joint Venture

When a DBE performs as a participant in a joint venture, the Design-Build Team may count toward its contract goal requirement a portion of the total value of participation with the DBE in the joint venture, that portion of the total dollar value being a distinct clearly defined portion of work that the DBE performs with its forces.

(E) Suppliers

A Design-Build Team may count toward its DBE requirement 60.0 percent of its expenditures for materials and supplies required to complete the contract and obtained from a DBE regular dealer and 100.0 percent of such expenditures from a DBE manufacturer.

(F) Manufacturers and Regular Dealers

A Design-Build Team may count toward its DBE requirement the following expenditures to DBE firms that are not manufacturers or regular dealers:

- (1) The fees or commissions charged by a DBE firm for providing a *bona fide* service, such as professional, technical, consultant, or managerial services, or for providing bonds or insurance specifically required for the performance of a DOT-assisted contract, provided the fees or commissions are determined to be reasonable and not excessive as compared with fees and commissions customarily allowed for similar services.
- (2) With respect to materials or supplies purchased from a DBE, which is neither a manufacturer nor a regular dealer, count the entire amount of fees or commissions charged for assistance in the procurement of the materials and supplies, or fees or transportation charges for the delivery of materials or supplies required on a job site (but not the cost of the materials and supplies themselves), provided the fees are determined to be reasonable and not excessive as compared with fees customarily allowed for similar services.

Commercially Useful Function

(A) DBE Utilization

The Design-Build Team may count toward its contract goal requirement only expenditures to DBEs that perform a commercially useful function in the work of a contract. A DBE performs a commercially useful function when it is responsible for execution of the work of the contract and is carrying out its responsibilities by actually performing, managing, and supervising the work involved. To perform a commercially useful function, the DBE shall also be responsible with respect to materials and supplies used on the contract, for negotiating price, determining quality and quantity, ordering the material and installing (where applicable) and paying for the material itself. To determine whether a DBE is performing a commercially useful function, the Department will evaluate the amount of work subcontracted, industry practices, whether the amount the firm is to be paid under the contract is commensurate with the work it is actually performing and the DBE credit claimed for its performance of the work, and any other relevant factors.

(B) DBE Utilization in Trucking

The following factors will be used to determine if a DBE trucking firm is performing a commercially useful function:

- (1) The DBE shall be responsible for the management and supervision of the entire trucking operation for which it is responsible on a particular contract, and there shall not be a contrived arrangement for the purpose of meeting DBE goals.
- (2) The DBE shall itself own and operate at least one fully licensed, insured, and operational truck used on the contract.
- (3) The DBE receives credit for the total value of the transportation services it provides on the contract using trucks it owns, insures, and operates using drivers it employs.
- (4) The DBE may subcontract the work to another DBE firm, including an owner-operator who is certified as a DBE. The DBE who subcontracts work to another DBE receives credit for the total value of the transportation services the subcontracted DBE provides on the contract.
- (5) The DBE may also subcontract the work to a non-DBE firm, including from an owner-operator. The DBE who subcontracts the work to a non-DBE is entitled to credit for the total value of transportation services provided by the non-DBE subcontractor not to exceed the value of transportation services provided by DBE-owned trucks on the contract. Additional participation by non-DBE subcontractors receives credit only for the fee or commission it receives as a result of the subcontract arrangement. The value of services performed under subcontract agreements between the DBE and the Design-Build Team will not count towards the DBE contract requirement.
- (6) A DBE may lease truck(s) from an established equipment leasing business open to the general public. The lease must indicate that the DBE has exclusive use of and control over the truck. This requirement does not preclude the leased truck from working for others during the term of the lease with the consent of the DBE, so long as the lease gives the DBE absolute priority for use of the leased truck. This type of lease may count toward the DBE's credit as long as the driver is under the DBE's payroll.
- (7) Subcontracted / leased trucks shall display clearly on the dashboard the name of the DBE that they are subcontracted / leased to and their own company name if it is not identified on the truck itself. Magnetic door signs are not permitted.

DBE Replacement

When a Design-Build Team has relied on a commitment to a DBE subcontractor (or an approved substitute DBE subcontractor) to meet all or part of a contract goal requirement, the Design-Build Team shall not terminate the DBE subcontractor for convenience. This includes, but is not limited to, instances in which the Design-Build Team seeks to perform the work of the terminated subcontractor with another DBE subcontractor, a non-DBE subcontractor, or with the Contractor's own forces or those of an affiliate.

The Design-Build Team must give notice in writing both by certified mail and email to the DBE subcontractor, with a copy to the Engineer of its intent to request to terminate and/or substitute, and the reason for the request. The Design-Build Team must give the DBE subcontractor five (5) business days to respond to the Design-Build Team's Notice of Intent to Request Termination and/or Substitution. If the DBE subcontractor objects to the intended termination/substitution, the DBE, within five (5) business days must advise the Design-Build Team and the Department of the reasons why the action should not be approved. The five-day notice period shall begin on the next business day after written notice is provided to the DBE subcontractor.

A committed DBE subcontractor may only be terminated after receiving the Department's written approval based upon a finding of good cause for the proposed termination and/or substitution. For purposes of this section, good cause shall include the following circumstances:

- (a) The listed DBE subcontractor fails or refuses to execute a written contract;
- (b) The listed DBE subcontractor fails or refuses to perform the work of its subcontract in a way consistent with normal industry standards. Provided, however, that good cause does not exist if the failure or refusal of the DBE subcontractor to perform its work on the subcontract results from the bad faith or discriminatory action of the prime contractor;
- (c) The listed DBE subcontractor fails or refuses to meet the prime contractor's reasonable, nondiscriminatory bond requirements;
- (d) The listed DBE subcontractor becomes bankrupt, insolvent, or exhibits credit unworthiness;
- (e) The listed DBE subcontractor is ineligible to work on public works projects because of suspension and debarment proceedings pursuant to 2 CFR Parts 180, 215 and 1,200 or applicable state law;
- (f) The listed DBE subcontractor is not a responsible contractor;
- (g) The listed DBE voluntarily withdraws from the project and provides written notice of withdrawal;
- (h) The listed DBE is ineligible to receive DBE credit for the type of work required;
- (i) A DBE owner dies or becomes disabled with the result that the listed DBE contractor is unable to complete its work on the contract;
- (j) Other documented good cause that compels the termination of the DBE subcontractor. Provided, that good cause does not exist if the prime contractor seeks to terminate a DBE it relied upon to obtain the contract so that the prime contractor can self-perform the work for which the DBE contractor was engaged or so that the prime contractor can substitute another DBE or non-DBE contractor after contract award.

The Design-Build Team shall comply with the following for replacement of a committed DBE:

(A) Performance Related Replacement

When a committed DBE is terminated for good cause as stated above, an additional DBE that was submitted at the time of bid may be used to fulfill the DBE commitment. A good faith effort will only be required for removing a committed DBE if there were no additional DBEs submitted at the time of bid to cover the same amount of work as the DBE that was terminated.

If a replacement DBE is not found that can perform at least the same amount of work as the terminated DBE, the Design-Build Team shall submit a good faith effort documenting the steps taken. Such documentation shall include, but not be limited to, the following:

- (1) Copies of written notification to DBEs that their interest is solicited in contracting the work defaulted by the previous DBE or in subcontracting other items of work in the contract.
 - (2) Efforts to negotiate with DBEs for specific subbids including, at a minimum:
 - (a) The names, addresses, and telephone numbers of DBEs who were contacted.
 - (b) A description of the information provided to DBEs regarding the plans and specifications for portions of the work to be performed.
 - (3) A list of reasons why DBE quotes were not accepted.
 - (4) Efforts made to assist the DBEs contacted, if needed, in obtaining bonding or insurance required by the Design-Build Team.
- (B) Decertification Replacement
- (1) When a committed DBE is decertified by the Department after the SAF (*Subcontract Approval Form*) has been received by the Department, the Department will not require the Design-Build Team to solicit replacement DBE participation equal to the remaining work to be performed by the decertified firm. The participation equal to the remaining work performed by the decertified firm will count toward the contract goal requirement.
 - (2) When a committed DBE is decertified prior to the Department receiving the SAF (*Subcontract Approval Form*) for the named DBE firm, the Design-Build Team shall take all necessary and reasonable steps to replace the DBE subcontractor with another DBE subcontractor to perform at least the same amount of work to meet the DBE goal requirement. If a DBE firm is not found to do the same amount of work, a good faith effort must be submitted to NCDOT (Reference A herein for required documentation).

All requests for replacement of a committed DBE firm shall be submitted to the Engineer for approval on Form RF-1 (*DBE Replacement Request*). If the Design-Build Team fails to follow this procedure, the Prime Contractor or other affiliated companies within the Design-Build Team may be disqualified from further bidding for a period of up to six months.

Changes in the Work

When the Engineer makes changes that result in the reduction or elimination of work to be performed by a committed DBE, the Design-Build Team will not be required to seek additional participation. When the Engineer makes changes that result in additional work to be performed by

a DBE based upon the Design-Build Team's commitment, the DBE shall participate in additional work to the same extent as the DBE participated in the original contract work.

When the Engineer makes changes that result in extra work, which has more than a minimal impact on the contract amount, the Design-Build Team shall seek additional participation by DBEs unless otherwise approved by the Engineer.

When the Engineer makes changes that result in an alteration of plans or details of construction, and a portion or all of the work had been expected to be performed by a committed DBE, the Design-Build Team shall seek participation by DBEs unless otherwise approved by the Engineer.

When the Design-Build Team requests changes in the work that result in the reduction or elimination of work that the Design-Build Team committed to be performed by a DBE, the Design-Build Team shall seek additional participation by DBEs equal to the reduced DBE participation caused by the changes.

Reports and Documentation

A SAF (*Subcontract Approval Form*) shall be submitted for all work which is to be performed by a DBE subcontractor. The Department reserves the right to require copies of actual subcontract agreements involving DBE subcontractors.

When using transportation services to meet the contract commitment, the Design-Build Team shall submit a proposed trucking plan in addition to the SAF. The plan shall be submitted prior to beginning construction on the project. The plan shall include the names of all trucking firms proposed for use, their certification type(s), the number of trucks owned by the firm, as well as the individual truck identification numbers, and the line item(s) being performed.

Within 30 calendar days of entering into an agreement with a DBE for materials, supplies or services, not otherwise documented by the SAF as specified above, the Design-Build Team shall furnish the Engineer a copy of the agreement. The documentation shall also indicate the percentage (60.0% or 100.0%) of expenditures claimed for DBE credit.

Reporting Disadvantaged Business Enterprise Participation

The Design-Build Team shall provide the Engineer with an accounting of payments made to all DBE firms, including material suppliers and contractors at all levels (prime, subcontractor, or second tier subcontractor). This accounting shall be furnished to the Engineer for any given month by the end of the following month. Failure to submit this information accordingly may result in the following action:

- (A) Withholding of money due in the next partial pay estimate; or
- (B) Removal of an approved Prime Contractor or other affiliated companies within the Design-Build Team from the prequalified bidders' list or the removal of other entities from the approved subcontractors list.

While each contractor (prime, subcontractor, 2nd tier subcontractor) is responsible for accurate accounting of payments to DBEs, it shall be the prime contractor's responsibility to report all monthly and final payment information in the correct reporting manner.

Failure on the part of the Design-Build Team to submit the required information in the time frame specified may result in the disqualification of that Prime Contractor and any affiliate companies within the Design-Build Team from further bidding until the required information is submitted.

Failure on the part of any subcontractor to submit the required information in the time frame specified may result in the disqualification of that Prime Contractor or any affiliate companies within the Design-Build Team from being approved for work on future DOT projects until the required information is submitted.

Design-Build Teams reporting transportation services provided by non-DBE lessees shall evaluate the value of services provided during the month of the reporting period only.

At any time, the Engineer can request written verification of subcontractor payments.

The Design-Build Team shall report the accounting of payments through the Department's DBE Payment Tracking System.

Failure to Meet Contract Requirements

Failure to meet contract requirements in accordance with Subarticle 102-15(J) of the 2018 *Standard Specifications for Roads and Structures* may be cause to disqualify the Prime Contractor or any affiliated companies within the Design-Build Team from further bidding for a specified length of time.

CERTIFICATION FOR FEDERAL-AID CONTRACTS

(3-21-90)

DB1 G85

The Proposer certifies, by signing and submitting a Design-Build Proposal, to the best of his or her knowledge and belief, that:

- (1) No Federal appropriated funds have been paid or will be paid, by or on behalf of the undersigned, to any person for influencing or attempting to influence an officer or employee of any Federal agency, a Member of Congress, an officer or employee of Congress, or an employee of a Member of Congress in connection with the awarding of any Federal contract, the making of any Federal grant, the making of any Federal loan, the entering into of any cooperative agreement, and the extension, continuation, renewal, amendment, or modification of any Federal contract, grant, loan, or cooperative agreement.
- (2) If any funds other than Federal appropriated funds have been paid or will be paid to any person for influencing or attempting to influence an officer or employee of any Federal agency, a Member of Congress, an officer or employee of Congress, or an employee of a Member of Congress in connection with this Federal contract, grant, loan, or cooperative agreement, the undersigned shall complete and submit Standard Form-LLL, *Disclosure Form to Report Lobbying*, in accordance with its instructions.

This certification is a material representation of fact upon which reliance was placed when this transaction was made or entered into. Submission of this certification is a prerequisite for making or entering into this transaction imposed by *Section 1352, Title 31, U.S. Code*. Any person who fails to file the required certification shall be subject to a civil penalty of not less than \$10,000 and not more than \$100,000 for each such failure.

The Proposer also agrees by submitting a Design-Build Proposal that he or she shall require that the language of this certification be included in all lower tier subcontracts, which exceed \$100,000 and that all such sub-recipients shall certify and disclose accordingly.

CONTRACTOR'S LICENSE REQUIREMENTS

(7-1-95)

DB1 G88

If the Design-Build Team does not hold the proper license to perform any plumbing, heating, air conditioning, or electrical work in this contract, he will be required to sublet such work to a contractor properly licensed in accordance with *Article 2 of Chapter 87 of the General Statutes* (licensing of heating, plumbing, and air conditioning contractors) and *Article 4 of Chapter 87 of the General Statutes* (licensing of electrical contractors).

U.S. DEPARTMENT OF TRANSPORTATION HOTLINE

(11-22-94)

108-5

DB1 G100

To report bid rigging activities call: **1-800-424-9071**

The U.S. Department of Transportation (DOT) operates the above toll-free hotline Monday through Friday, 8:00 a.m. to 5:00 p.m. eastern time. Anyone with knowledge of possible bid rigging, bidder collusion, or other fraudulent activities should use the hotline to report such activities.

The hotline is part of the DOT's continuing effort to identify and investigate highway construction contract fraud and abuse is operated under the direction of the DOT Inspector General. All information will be treated confidentially and caller anonymity will be respected.

CARGO PREFERENCE ACT

(2-16-16)

DB1 G100

Privately owned United States-flag commercial vessels transporting cargoes are subject to the Cargo Preference Act (CPA) of 1954 requirements and regulations found in 46 CFR 381.7. Contractors are directed to clause (b) of 46 CFR 381.7 as follows:

(b) Contractor and Subcontractor Clauses. "Use of United States-flag vessels: The contractor agrees-

“(1) To utilize privately owned United States-flag commercial vessels to ship at least 50 percent of the gross tonnage (computed separately for dry bulk carriers, dry cargo liners, and tankers) involved, whenever shipping any equipment, material, or commodities pursuant to this contract, to the extent such vessels are available at fair and reasonable rates for United States-flag commercial vessels.

(2) To furnish within 20 days following the date of loading for shipments originating within the United States or within 30 working days following the date of loading for shipments originating outside the United States a legible copy of a rated, 'on-board' commercial ocean bill-of-lading in English for each shipment of cargo described in paragraph (b) (1) of this section to both the Contracting Officer (through the prime contractor in the case of subcontractor bills-of-lading) and to the Division of National Cargo, Office of Market Development, Maritime Administration, Washington, DC 20590.

(3) To insert the substance of the provisions of this clause in all subcontracts issued pursuant to this contract."

SUBSURFACE INFORMATION

(3-22-07)

DB1 G112D

Available subsurface information will be provided on this project. The Design-Build Team shall be responsible for additional investigations and for verifying the accuracy of the subsurface information supplied by the Department.

COOPERATION BETWEEN CONTRACTORS

(07/1/95) (Rev 01-11-08)

DB1 G133

The Design-Build Team's attention is directed to Article 105-7 of the *Standard Specifications for Roads and Structures*. The following projects are in the immediate vicinity of R-2721A:

- **R-2721B** - Wake County, Design-Build Triangle Expressway from the end of the this project to east of US 401

The Design-Build Team on this project shall cooperate with the Design-Build Teams or contractors working within or adjacent to the limits of this project to the extent that the work can be carried out to the best advantage of all concerned.

The NCTA will advertise and select a contractor for Landscaping after the award of this contract and therefore no landscaping shall be included in the Design-Build Team's Price Proposal. This contract will encompass the entire corridor and construction will be performed concurrent with this Design-Build contract. The landscape contract, and the availability of landscape work areas will be structured to accommodate the Design-Build Team's construction sequence. The Design-Build Team shall coordinate with the Toll System Integrator in the planning, scheduling, design and construction of the elements that are collective to both entities. The Design-Build Team shall integrate the toll system integration schedules into the CPM schedule and make work areas available, as needed, to successfully meet the contract substantial completion date and contract completion dates. Close coordination with the Toll System Integrator is essential.

The Design-Build Team for this project shall be required to meet and coordinate with the Toll Integration, Landscaping, and any other Contractors necessary to successfully plan, design, and construct the project.

Meetings shall be scheduled and attended by authorized representatives of this Design-Build Team and include personnel from the Toll Integration Contractor, Landscaping Contractor, any other

pertinent Contractors, and representatives from the NCTA and NCDOT. At a minimum, there shall be a pre-construction meeting, meetings during the construction process, and a post-construction meeting. One final meeting shall be held to reach concurrence that all the construction and toll facility components have been installed properly and function to provide the ability to collect revenue from this freeway.

PRICE PROPOSAL DOCUMENTATION

(7-31-12) (Rev. 8-3-15)

DB1 G142

General

The successful Design-Build Team shall submit the original, unaltered Price Proposal documentation or a certified copy of the original, unaltered Price Proposal documentation used to prepare the Price Proposal for this contract to the Department within ten days after receipt of notice of award of contract. Such documentation shall be placed in escrow with a banking institution or other bonded document storage facility selected by the Department.

The Department and the NCTA will not execute the contract until the original, unaltered Price Proposal documentation or a certified copy of the original, unaltered Price Proposal documentation has been received by the Department.

Terms

Price Proposal Documentation – Price Proposal Documentation shall mean all written information, working papers, computer printouts, electronic media, charts, and all other data compilations which contain or reflect information, data, and calculations used by the Proposer in the preparation of the Price Proposal. The term *Price Proposal documentation* includes, but is not limited to, Design-Build Team equipment rates, Design-Build Team overhead rates, labor rates, efficiency or productivity factors, arithmetical calculations, and quotations from subcontractors and material suppliers to the extent that such rates and quotations were used by the Proposer in formulating and determining the Price Proposal. The term *Price Proposal documentation* also includes any manuals, which are standard to the industry used by the Proposer in determining the Price Proposal. Such manuals may be included in the Price Proposal documentation by reference. Such reference shall include the name and date of the publication and the publisher. *Price Proposal Documentation* does not include bid documents provided by the Department for use by the Proposer in bidding on this project. The Price Proposal Documentation can be in the form of electronic submittal (i.e. thumb drive) or paper. If the Bidder elects to submit the Bid Documentation in electronic format, the Department requires a backup submittal (i.e. a second thumb drive) in case one is corrupted.

Design-Build Team's Representative – Officer of the Prime Contractor's company; if not an officer, the Contractor shall supply a letter signed and notarized by an officer of the Prime Contractor's company, granting permission for the representative to sign the escrow agreement on behalf of the Prime Contractor.

Escrow Agent – Officer of the select banking institution or other bonded document storage facility authorized to receive and release Price Proposal documentation.

Escrow Agreement Information

A draft copy of the Escrow Agreement will be mailed to the Proposer after the notice of award for informational purposes. The Proposer and Department will sign the actual Escrow Agreement at the time the Price Proposal documentation is delivered to the Escrow Agent.

Failure to Provide Price Proposal Documentation

The Proposer's failure to provide the original, unaltered Price Proposal documentation or a certified copy of the original, unaltered Price Proposal documentation within ten days after the notice of award is received by him may be just cause for rescinding the award of the contract and may result in the removal of the Proposer from the Department's list of qualified bidders for a period of up to 180 days. Award may then be made to the Proposer with the next lowest adjusted price or the work may be readvertised and constructed under the contract or otherwise, as the NCTA may decide.

Submittal of Price Proposal Documentation

- (A) Appointment – Email specs@ncdot.gov or call 919.707.6900 to schedule an appointment.
- (B) Delivery - A representative of the Proposer shall deliver the original, unaltered Price Proposal documentation or a certified copy of the original, unaltered Price Proposal documentation to the Department, in a container suitable for sealing, within ten days after the notice of award is received.
- (C) Packaging – The container shall be no larger than 15.5 inches in length by 12 inches wide by 11 inches high and shall be water resistant. The container shall be clearly marked on the face and the back of the container with the following information: Price Proposal Documentation, Bidder's Name, Bidder's Address, Date of Escrow Submittal, Contract Number, TIP Number if applicable, and County.

Affidavit

Price Proposal documentation will be considered a certified copy if the Proposer includes an affidavit stating that the enclosed documentation is an EXACT copy of the original documentation used by the Proposer to determine the bid for this project. The affidavit shall also list each Price Proposal document with sufficient specificity so a comparison may be made between the list and the Price Proposal documentation to ensure that all of the Price Proposal documentation listed in the affidavit has been enclosed for escrow. The affidavit shall attest that the affiant has personally examined the Price Proposal documentation, that the affidavit lists all of the documents used by the proposer to determine the bid for this project, and that all Price Proposal documentation has been included. The affidavit shall be signed by a chief officer of the company, have the person's name and title typed below the signature, and the signature shall be notarized at the bottom of the affidavit.

Verification

Upon delivery of the Price Proposal documentation, the Department's Contract Officer and the Design-Build Team's representative will verify the accuracy and completeness of the Price Proposal documentation compared to the affidavit. Should a discrepancy exist, the Design-Build Team's representative shall immediately furnish the Department's Contract Officer with any other needed Price Proposal documentation. The Department's Contract Officer upon determining that the Price Proposal documentation is complete will, in the presence of the Design-Build Team's representative, immediately place the complete Price Proposal documentation and affidavit in the container and seal it. Both parties will deliver the sealed container to the Escrow Agent for placement in a safety deposit box, vault, or other secure accommodation.

Confidentiality of Price Proposal Documentation

The Price Proposal documentation and affidavit in escrow are, and will remain, the property of the Proposer. The Department has no interest in, or right to, the Price Proposal documentation and affidavit other than to verify the contents and legibility of the Price Proposal documentation unless the Design-Build Team gives written notice of intent to file a claim, files a written claim, files a written and verified claim, or initiates litigation against the Department or NCTA. In the event of such written notice of intent to file a claim, filing of a written claim, filing a written and verified claim, or initiation of litigation against the Department or NCTA, or receipt of a letter from the Design-Build Team authorizing release, the Price Proposal documentation and affidavit may become the property of the Department for use in considering any claim or in litigation as the Department may deem appropriate.

Any portion or portions of the Price Proposal documentation designated by the Proposer as a *trade secret* at the time the Price Proposal documentation is delivered to the Department's Contract Officer shall be protected from disclosure as provided by *G.S. 132-1.2*.

Duration and Use

The Price Proposal documentation and affidavit shall remain in escrow until 60 calendar days from the time the Prime Contractor receives the final estimate; or until such time as the Design-Build Team:

- (A) Gives written notice of intent to file a claim,
- (B) Files a written claim,
- (C) Files a written and verified claim,
- (D) Initiates litigation against the Department or NCTA related to the contract; or
- (E) Authorizes in writing its release.

Upon the giving of written notice of intent to file a claim, filing a written claim, filing a written and verified claim, or the initiation of litigation by the Design-Build Team against the Department or NCTA, or receipt of a letter from the Design-Build Team authorizing release, the Department or NCTA may obtain the release and custody of the Price Proposal documentation.

The Proposer certifies and agrees that the sealed container placed in escrow contains all of the Price Proposal documentation used to determine the Price Proposal and that no other Price Proposal documentation shall be relevant or material in litigation over claims brought by the Design-Build Team arising out of this contract.

Release of Price Proposal Documentation to the Contractor

If the Price Proposal documentation remains in escrow 60 calendar days after the time the Design-Build Team receives the final estimate and the Design-Build Team has not filed a written claim, filed a written and verified claim, or has not initiated litigation against the Department or NCTA related to the contract, the Department will instruct the Escrow Agent to release the sealed container to the Prime Contractor.

The Prime Contractor will be notified by certified letter from the Escrow Agent that the Price Proposal documentation will be released to the Prime Contractor. The Prime Contractor or his representative shall retrieve the Price Proposal documentation from the Escrow Agent within 30 days of the receipt of the certified letter. If the Prime Contractor does not receive the documents within 30 days of the receipt of the certified letter, the Department will contact the Prime Contractor to determine final dispersion of the Price Proposal documentation.

Payment

The cost of the escrow will be borne by the Department. There will be no separate payment for all costs of compilation of the data, container, or verification of the Price Proposal documentation. Payment at the various contract unit or lump sum prices in the contract will be full compensation for all such costs.

DISPUTE REVIEW BOARD (DRB)

GENERAL

A. Definitions

Dispute – A contractual issue that involves cost and/or time (either credits or additions) that remains unresolved following good faith negotiations between authorized representatives of the Design-Build Team and the North Carolina Turnpike Authority (NCTA).

Dispute Review Board (DRB) – three neutral individuals, selected as provided herein, who review Disputes and renders findings and recommendations based on the Contract.

B. Formal DRB Review

This provision provides for a formal DRB review process.

Any of the procedures for the formal DRB Review established by this provision may be altered or modified by mutual written agreement of the Design-Build Team and the NCTA to better suit the needs of a particular Dispute.

C. Summary

A DRB will be established to assist in the analysis of Disputes that arise between the Design-Build Team and the NCTA, to include, but not be limited to, Articles 104-4, 104-8(B) or 108-10 of the 2018 *Standard Specifications for Roads and Structures*.

It is not intended for the NCTA or the Design-Build Team to default on their normal responsibilities to cooperatively and fairly settle their differences by indiscriminately assigning them to the DRB. It is intended that the DRB encourage the NCTA and Design-Build Team to resolve potential disputes without resorting to this alternative resolution procedure.

Utilization of the DRB does not relieve the Design-Build Team or NCTA from complying with all Contract terms and conditions, and does not waive any notice or timeliness requirements of the *Standard Specifications for Roads and Structures*. However, if a Dispute is referred to the DRB, the claim submittal and review time frames may be superseded by time frames established by the DRB, and agreed to in writing by both the Design-Build Team and the NCTA.

Either the Design-Build Team or the NCTA may refer a Dispute to the DRB. Such referral should be initiated as soon as it appears that the normal NCTA-Design-Build Team dispute resolution effort is not succeeding. However, prior to referring a Dispute to the DRB, the NCTA and Design-Build Team must agree on the central or core issue to bring before the DRB.

Promptly thereafter, the DRB will impartially consider the Dispute(s) referred to it. The DRB will provide non-binding written findings and recommendations to the Design-Build Team and the NCTA.

Although the findings and recommendations of the DRB should carry great weight for both the Design-Build Team and the NCTA, they are not binding on either the Design-Build Team or the NCTA.

The Dispute Review Board is a condition of this Contract. The NCTA and the Design-Build Team agree that the submission of any unresolved dispute or claim to the DRB is a condition precedent to the Design-Build Team submitting a final claim.

D. Scope

This provision describes the purpose, procedure, function, and features of the DRB. A Three-Party Agreement among the NCTA, Design-Build Team, and the selected DRB members will formalize creation of the DRB and establish the scope of its services and the rights and responsibilities of the Design-Build Team and the NCTA.

E. Purpose

The purpose of the DRB is to provide an independent and impartial review of the Dispute and provide non-binding written findings and recommendations, in accordance with the Contract, applicable contract law, industry practices, and the facts presented.

It is not the purpose, or responsibility, of the DRB to resolve the Dispute. That responsibility remains with the Design-Build Team and the NCTA. However, it is anticipated that the DRB review will assist the Design-Build Team and the NCTA in resolving the Dispute.

Creation of the DRB is not intended as a substitute for NCTA or Design-Build Team responsibility to make a good-faith effort to settle the Dispute. Indiscriminate referral of disputes to the DRB without prior attempts by the Design-Build Team and the NCTA to resolve them shall be avoided. The Design-Build Team or NCTA shall exhaust resolution through normal processes and an agreed upon escalation process prior to escalating an issue to the DRB.

F. Continuance of Work

Both the Design-Build Team and the NCTA shall proceed diligently with the work and comply with all applicable Contract provisions while the DRB considers a Dispute.

G. Tenure of DRB

The DRB will be deemed established after the NCTA, the Design-Build Team and the DRB execute the Three-Party Agreement.

The DRB will be dissolved as of the end of the contract unless earlier terminated or dissolved by mutual agreement of the Design-Build Team and the NCTA. If mutually agreed upon by the Design-Build Team and the NCTA, the DRB may be dissolved on the date of final payment to the Design-Build Team.

MEMBERSHIP

General

The DRB will consist of three members selected as provided below.

B. Criteria

Experience

1. It is desirable that all DRB members be experienced with the construction process including design, construction, contract administration, contract law, and resolution of construction disputes.
2. It is not necessary that the DRB members be intimately familiar with the specific type of construction involved in the Dispute. The DRB may consult technical experts if the need arises under provisions provided for elsewhere in this Special Provision

Neutrality

1. It is imperative that the DRB members be neutral, act impartially, and be free of any conflict of interest.

2. For purposes of this subparagraph, the term “member” also includes the member’s current primary or full-time employer, and “involved” means having a contractual relationship with either the Design-Build Team or the NCTA, such as a subcontractor, architect, engineer, or construction manager.
3. Prohibitions; disqualifying relationships for prospective members:
 - (a) An ownership interest in any entity involved in the Project or Contract, or a financial interest in the Contract, except for payment for services on this Dispute Review Board;
 - (b) Previous employment by, or financial ties to, any party involved in the Contract within a period of eighteen (18) months prior to award of the Contract, except for fee-based consulting services on other projects;
 - (c) A close professional or personal relationship with any key member of any entity involved in the Contract which, in the judgment of either the Design-Build Team or the NCTA, could suggest partiality; or
 - (d) Prior involvement in the project of a nature that could compromise the prospective member’s ability to participate impartially in the DRB’s activities.
4. Prohibitions; disqualifying relationships for members:
 - (a) Employment, including fee-based consulting services, by any entity involved in the construction contract except with the express approval of both the Design-Build Team and the NCTA;
 - (b) Discussion concerning, or the making of, an agreement with any entity involved in the Contract regarding employment after the Contract is completed.
5. Any of the provisions of 1 through 4 above may be waived by mutual written agreement of the Design-Build Team and the NCTA.

C. Disclosure Statement

As a part of the selection process, all prospective DRB members will be required to submit complete disclosure statements for the approval of both the Design-Build Team and the NCTA. Each statement shall include a resume of experience, together with a declaration describing all past, present, and anticipated or planned future relationships, including indirect relationships through the prospective member’s primary or full-time employer, to this project and with the Design-Build Team or the NCTA, or others involved in the Contract, including subcontractors, suppliers, design professionals, and consultants. Disclosure of close professional or personal relationships with all key members of the Design-Build Team or the NCTA or other parties involved in the construction Contract shall be included.

D. Selection Process

Within 30 calendar days of the Unlimited Notice to Proceed, or as otherwise mutually agreed upon by the Design-Build Team and NCTA, the Design-Build Team and the NCTA will jointly select the DRB using the following procedure:

1. To form a DRB, the NCTA will provide to the Design-Build Team a copy of the resume and references of the person proposed for the DRB. Likewise, the Design-Build Team will provide NCTA the resume and references for their proposed DRB Member. The Design-Build Team and the NCTA will confirm the availability, neutrality, experience, and expertise of the nominees. Both the NCTA and Design-Build Team will have the ability to reject the others nominee. The parties shall continue to exchange nominee information until each party has selected a nominee that is acceptable to the other party. The NCTA shall be responsible for notifying the nominees of their selection.
2. Once the two mutually agreeable nominees have confirmed their participation within the DRB, they shall be responsible for selecting a third DRB member, who shall become the DRB Chairperson.
3. Should the need arise to select a replacement DRB member; the replacement member shall be selected in the same manner that the member to be replaced was selected.

E. Three-Party Agreement

The DRB members and the authorized representatives of the Design-Build Team and the NCTA shall execute the Dispute Review Board Three-Party Agreement within 2 weeks after the selections are made.

OPERATION

A. General

The DRB will operate in accordance with this provision. The DRB may initiate, with the concurrence of the NCTA and Design-Build Team, new procedures or modifications to existing procedures as it deems appropriate.

B. Contract Documents, Reports and Information

The NCTA will provide a set of the contract documents to each DRB member.

The DRB members will be kept informed of construction activity and other developments by means of timely transmittal of relevant information requested by the DRB and prepared by the Design-Build Team and the NCTA in the normal course of construction, including, but not limited to, periodic reports and minutes of progress meetings. At any time, the DRB may request copies of documents that are normally generated by the Design-Build Team or the NCTA during the course of business throughout the Project. Only during the resolution of a specific dispute may the DRB request reports, documents or other information that is not normally generated during the course of business, and this information shall be limited to that which is specific to this dispute.

C. Periodic Meetings and Visits

Meetings or site visits may be needed as mutually agreed among the NCTA, the Design-Build Team, and the DRB.

Site visits should cover all active segments of the work. Representatives of both the Design-Build Team and the NCTA shall accompany the DRB during project meetings or site visits.

The DRB shall be provided “issue logs” and “Supplemental Agreement/Change Order Logs” throughout the life of the contract.

REVIEW OF DISPUTES

A. General

The Design-Build Team and the NCTA will cooperate to ensure that the DRB considers Disputes promptly, taking into consideration the particular circumstances and the time required to prepare appropriate documentation.

Procedures and time periods may be modified by mutual agreement.

B. Prerequisites to Review

A Dispute is subject to referral to the DRB when either the Design-Build Team or the NCTA believes that bilateral negotiations have reached an impasse. However, the NCTA and Design-Build Team must agree on the central or core issue to bring before the DRB prior to referring a dispute to the DRB.

C. Requesting Review

Either the Design-Build Team or the NCTA may refer a dispute to the DRB. Requests for DRB review shall be submitted in writing to the Chairperson of the DRB. The Request for Review shall state clearly and in full detail the specific core issue of the Dispute to be considered by the DRB. A copy of the request shall be simultaneously provided to the other party.

After conferring with both the Design-Build Team and the NCTA, the DRB Chairperson will establish a submittal/presentation schedule. Unless the Design-Build Team and the NCTA both agree otherwise, the presentation shall be scheduled no sooner than 30 days after receipt of the Request for Review and no sooner than 14 days after receipt of the rebuttal information.

Concise written position statements shall be prepared by both the Design-Build Team and the NCTA, with page number references to any supporting documentation, and submitted to each DRB member and simultaneously to the other party.

Any rebuttal information to the position statements shall be submitted to each DRB member and simultaneously to the other party.

D. Presentation

Unless otherwise agreed by the DRB, the Design-Build Team and the NCTA, the presentation will be conducted at the NCTA office. However, any location that would be more convenient and still provide all required facilities and access to necessary documentation is satisfactory. Private deliberations of the DRB may be held at any convenient location.

The Design-Build Team and the NCTA shall have representatives in attendance at all presentations. The party that brought the dispute before the DRB will make its presentation first. A full presentation of the dispute shall be allowed without interruption, except from the DRB. Once all information is presented the other party may provide a rebuttal, at which time each party will be allowed successive rebuttals until all aspects of the dispute are fully covered. The DRB members, the Design-Build Team and the NCTA may ask questions, request clarification, or ask for additional data. In difficult or complex cases, additional presentations may be necessary in order to facilitate full consideration and understanding of all the evidence presented by both the Design-Build Team and the NCTA. Both the Design-Build Team and the NCTA shall be provided adequate opportunity to present their evidence, documentation, and statement regarding all issues before the DRB. No documents, materials, reports, analysis or other information of any type shall be referenced in the presentations or considered by the DRB in its review unless the same was previously provided to the other party as supporting documentation for the position statement.

Unless otherwise agreed by the Design-Build Team and the NCTA, presentations will relate to issues of entitlement only. Contract time extensions and compensation will be resolved between NCTA and the Design-Build Team, in accordance with the provisions of the 2018 *Standard Specifications for Roads and Structures* as amended by the Standard Special Provision entitled *Division One* contained elsewhere in this RFP.

Normally, a formal transcript of the presentations will not be prepared. When requested by either the Design-Build Team or the NCTA, the DRB may allow recordation and transcription with the cost to be allocated to the party requesting such documentation. Such transcript, when prepared, shall not constitute the official record of the DRB Review. The record prepared by the DRB shall be the official record of the DRB Review. The DRB may provide for audio or video recordings of the presentations for the use of the DRB only.

The Design-Build Team and the NCTA shall not have their attorneys in attendance at the presentations to counsel and/or advise them.

If either the Design-Build Team or the NCTA fails to appear before the DRB on the date scheduled for the presentations, without justifiable cause, the dispute will continue under the applicable provisions of the 2018 *NCDOT Standard Specifications for Roads and Structures* and this Contract.

E. Deliberations

After the presentation is concluded, the DRB will confer to formulate its findings and recommendations. All DRB deliberations shall be conducted in private, with all individual views kept confidential.

If the DRB desires technical assistance, the DRB will make a request in writing to both parties (Design-Build Team and NCTA) briefly defining the scope and estimated budget for the services. Direct attorney advisement or assistance is prohibited. If mutually agreeable, the Design-Build Team and NCTA will execute an agreement with a service provider. The Design-Build Team and NCTA will equally share the costs for the service provider. In the typical situation the special services provider will respond to questions from the DRB in private consultation between the provider and the DRB and no permanent record of the questions or responses will be required by the Design-Build Team or the NCTA. However, if mutually agreeable, these typical operating procedures may be modified. In arriving at its findings and recommendations, the DRB will not be bound by any information provided by the special service provider.

F. Findings and Recommendations

It is not the responsibility of the DRB to resolve the Dispute, only to make a recommendation based upon the contract documents and information supplied and presented before them. It shall remain the responsibility of the Design-Build Team and the NCTA to resolve all Disputes.

The findings and recommendations of the DRB will be provided in writing, by certified mail, return receipt requested, to both the Design-Build Team and the NCTA within 14 calendar days of the completion of the presentations or, when technical assistance is required, within 14 calendar days of receipt of technical assistance. The DRB should set forth, as clearly as possible, the logic and reasoning behind its findings and recommendations. The findings and recommendations will address entitlement only. In difficult or complex cases, and in consideration of the DRB member's schedule, this time may be extended by mutual agreement of the DRB, the Design-Build Team and the NCTA.

If the DRB is unable to reach unanimity in its findings and recommendations, the DRB will so advise the Design-Build Team and the NCTA in the report of the DRB. The DRB report shall consist of a majority opinion and, when the decision is not unanimous, a minority opinion.

G. Acceptance or Rejection

Within 30 calendar days of the date of the DRB's findings and recommendations, or such other time specified by the DRB, both the Design-Build Team and the NCTA shall provide, by certified mail return receipt requested, written notice to the other and to the DRB of acceptance or rejection of the DRB findings and recommendations.

If, with the aid of the DRB findings and recommendations, the Design-Build Team and the NCTA are able to resolve their Dispute, the NCTA will promptly process any required Contract changes.

If either the Design-Build Team or the NCTA rejects the findings and recommendations of the DRB, the Dispute will continue under the applicable provisions of the Contract.

H. Clarification and Reconsideration

Should the dispute remain unresolved because of a request for clarifications of the recommendation or new information or material becomes available which was not available at the time of the presentation, either the Design-Build Team or the NCTA may within the 7 calendar day period following the date of the DRB findings and recommendations, request in writing, by

certified mail return receipt requested, that the DRB clarify or reconsider its findings and recommendations. This information shall be supplied simultaneously to the other party.

Should new information be made available, the other party shall have 7 days to review such information and respond appropriately. After that period, the DRB shall promptly notify the Design-Build Team and the NCTA of any changes to DRB findings and recommendations.

I. Admissibility

If the DRB's findings and recommendations do not resolve the Dispute, the Contract, the written findings and recommendations, including any minority report, and the qualifications of the DRB members will be admissible as evidence to the extent permitted by law in any subsequent dispute resolution proceeding or forum to establish (a) that a DRB considered the Dispute, (b) the qualifications of the DRB members, and (c) the DRB's findings and recommendations that resulted from the process.

J. Legal Relations

Each DRB member, in the performance of his or her duties on the DRB, is acting in the capacity of an independent agent and not as an employee of either the Design-Build Team or the NCTA.

Each DRB member is acting in a capacity intended to facilitate resolution of Disputes. Accordingly, the Design-Build Team and the NCTA agree that to the fullest extent permitted by law, each DRB member shall be accorded quasi-judicial immunity for any actions or decisions associated with the review and findings and recommendations of Disputes referred to the DRB. No DRB member may be called as a witness by either the Design-Build Team or the NCTA in subsequent proceedings on the dispute. The DRB shall, upon completion of their findings, turn all records of the DRB over to the NCTA for storage and preservation.

By execution of the Three-Party Agreement, the Design-Build Team and the NCTA agree not to pursue legal proceedings against a DRB member for activities related to or consequences resulting from their participation in the DRB.

PAYMENT

A. Method of Measurement

The Design-Build Team and the NCTA shall equally bear the costs and expenses of the DRB.

The DRB members should not engage in activities related to the project, for which compensation is expected, unless requested by either the NCTA or Design-Build Team.

Time spent at formalized meetings or reviewing the Dispute – Each DRB member will be compensated for actual time spent at the rate of \$250 per hour with a maximum of \$2,000 per day. This rate shall include all normal incidental expenses such as telephone, fax, postage, courier, printing, and computer services. The DRB activity must be preauthorized by both the Design-Build Team and the NCTA.

Travel Time to and from Preauthorized Meetings – Each DRB member will be compensated for actual travel time to and from DRB meetings at the rate of \$50 per hour with a maximum of \$200 each way.

Travel Expenses – Travel expenses will be reimbursed at standard NC state rates for transportation, lodging, and meals for each day, or portion thereof, that the DRB member is traveling to or from, or attending, an authorized DRB activity. Expense receipts are required.

The NCTA will provide, at no cost to the Design-Build Team, administrative services such as conference facilities, meeting rooms and copying services during DRB presentations.

The Three Party Agreement and this Special Provision contain all of the provisions for compensation and expenses of the DRB. All DRB members shall be compensated at the same daily and hourly rate.

Each DRB member may submit invoices for payment for work completed and qualified expenses no more often than once per month during the progress of work. Such invoices shall be in a format approved by the NCTA, and accompanied by a general description of activities performed during that period. The value of work accomplished for payment shall be established from the billing rate and hours expended by the DRB member together with qualified expenses incurred.

The cost records and accounts pertaining to this Agreement shall be kept available for inspection by representatives of the NCTA or Design-Build Team for 5 years after final payment.

No additional compensation for services associated with the DRB, beyond that detailed above, will be provided to the DRB members.

B. Basis of Payment

Payment for accepted work will be made as follows:

The Design-Build Team shall pay the invoices of all DRB members after approval by both the Design-Build Team and the NCTA. The Design-Build Team shall then bill the NCTA for one-half of such invoices, which shall be processed in accordance with Article 104-7 of the *Standard Specifications*.

There shall be no markups applied to expenses connected with the DRB, either by the DRB members or by the Design-Build Team. Regardless of the DRB recommendation, neither the NCTA nor the Design-Build Team shall be entitled to reimbursement of DRB costs from the other party.

If the DRB desires special technical services, both the Design-Build Team and the NCTA must agree to provide the special services following the procedures included in the Dispute Review Board, Review of Disputes, Deliberations section, contained elsewhere in this provision. If such services are approved and rendered, payment will be made under these provisions in accordance with the Dispute Review Board, Review of Disputes, Deliberations section, contained elsewhere in this provision.

These special provisions and the Three Party Agreement contain all of the provisions for compensation and expenses of the DRB. All DRB members shall be compensated at the same daily and hourly rate.

THREE-YEAR GUARANTEE

GENERAL

The performance of remedial work in conjunction with this provision and guarantee is not an obligation of the Design-Build Team's bond required by G.S. 44A-33.

The Three-Year Guarantee applies to all Work on the project with the exception of vegetation establishment. Pavement and bridge characteristics have readily available condition parameters and therefore specific deficiency thresholds are established within this provision; however, the absence of such thresholds for other Work elements (e.g. slopes, signs) in this provision does not relieve the Design-Build Team of the Three-Year Guarantee for any and all Work elements on the project.

Definitions:

Work - The furnishing of all labor, materials, equipment, and incidentals necessary or convenient to the successful completion of the project, or any part, portion, or phase thereof, and the carrying out of all duties and obligations imposed by the contract.

Warranty Initiation Date - The date that constitutes the start date for the warranty term and coincides with the Substantial Completion as determined by NCTA.

Warranty Bond - A bond issued by a surety which guarantees that the warranty requirements, including any observation periods extending beyond the Substantial Completion Date will be satisfied.

Breach of Warranty – A failure to perform Corrective Work or Immediate Corrective Work in accordance with the provisions contained herein.

Dispute Review Board - The team responsible for resolving disputes between the NCTA and the Design-Build Team regarding any claim of noncompliance with the warranty requirements, as detailed elsewhere within the Contract Documents.

Corrective Work - Work redone, repaired, corrected or replaced pursuant to the terms of this Warranty Provision. This term is used throughout this provision to collectively mean both Corrective Work and Immediate Corrective Work.

Immediate Corrective Work - Work redone, repaired, corrected or replaced that shall be undertaken immediately as it poses an imminent danger to the users of the facilities constructed under this project. If the NCTA determines that Immediate Corrective Work is necessary for public safety, the NCTA or its agent may perform emergency repairs. Prior to such emergency repairs, the NCTA will document the basis for the emergency action and will preserve evidence of the defective condition.

Project Warranty Term

Excluding water and sewer work, the Warranty Term for each element of the Project shall commence upon Substantial Completion, as determined by NCTA, and shall remain in effect for three years (unless otherwise extended by the Design-Build Team in their Technical Proposal) thereafter subject to extension under the “Warranty Bond” section of this provision and notwithstanding any warranty term for specific Project elements that may be longer than the warranty term set forth herein. The Warranty Term for water and sewer work shall commence once all water and sewer work performed for that owner is accepted and shall remain in effect for three years thereafter subject to extension under the “Warranty Bond” section of this provision and notwithstanding any warranty term for specific Project elements that may be longer than the warranty term set forth herein.

These warranties are binding on the Design-Build Team’s successors, transferees, heirs, and assigns. If NCTA determines that any of the Work has not met the standards set forth in this Provision at any time within the Warranty Term, then the Design-Build Team shall correct such Work as specified below, even if the performance of such Corrective Work extends beyond the stated Warranty Term.

The Design-Build Team shall be responsible for any and all remediation activities at any on-site stream mitigation site for a period of twelve months following NCTA's final acceptance of the stream mitigation site at no additional cost to the NCTA.

Warranty Bond

The Design-Build Team shall furnish a single term warranty bond from a firm licensed to do business in the State of North Carolina, in an amount of five percent of the total amount bid for the entire project, as a prerequisite of determination of Substantial Completion. This bond will be applicable to the Project Warranty and any specific Project elements that may be set forth elsewhere in this Contract. The warranty bond will be released at the end of the warranty period to include any extension as provided in the “Warranty of Corrective Work” section below. Should such extensions occur on specific project elements, there may be the opportunity to lower the bond amount for such extension to cover the warranty of the Corrective Work. The NCTA will supply the Warranty Bond form upon request.

Initial Project Acceptance

The NCTA and the Design-Build Team shall jointly review all completed Work, or a portion thereof, as determined by the NCTA. If the work does not meet contract requirements, the Design-Build Team shall make all necessary corrections, at their expense, prior to initial acceptance. Initial acceptance will occur as soon as the NCTA confirms in writing, that contract requirements have been met and the Design-Build Team has reached Substantial Completion as defined in the Project Special Provision *Substantial Completion*. The date on which Substantial Completion occurs shall coincide with the Warranty Initiation Date. Once final acceptance of the Project or portions thereof is attained as defined by the NCTA, routine maintenance of such becomes the responsibility of the NCTA, excluding any items requiring Warranty Corrective Work as detailed within this Provision.

The date of Substantial Completion/Warranty Initiation Date will be documented and executed jointly by the NCTA and the Design-Build Team with a copy of such being sent to the Design-Build Team's warranty bond surety agent.

The NCTA may accept the work and begin the warranty period, excluding any area needing Corrective Work, to accommodate seasonal limitations or staged construction.

Neither the initial acceptance nor any prior inspection, acceptance or approval by the NCTA diminishes the Design-Build Team's responsibility under this warranty. Acceptance of material, in penalty, under the NCTA's quality assurance program will not relieve the Design-Build Team from meeting the material and workmanship warranty requirements for the accepted material.

Annual Review Process

The NCTA shall employ a private engineering firm to perform an annual review of the pavement and bridge components condition parameters warranted by this Provision. The private engineering firm will perform the appropriate testing, inspections and develop a report with all evaluation data and digital photographic status of the warranted condition parameters. This report will be dated and certified by a Professional Engineer registered in North Carolina. The report will be submitted directly to the NCTA with copies submitted to the Design-Build Team.

Final Warranty Acceptance

The NCTA and the Design-Build Team shall jointly conduct an inspection of the Project prior to expiration of the warranty term and shall produce a punch list of those items which require Corrective Work prior to fulfillment of the warranty obligation. If requirements of this Provision are not met, the Design-Build Team shall make all necessary corrections, at their expense, prior to expiration of the warranty term.

The date upon which the warranty terminates, including any extension as included in the "Warranty of Corrective Work" section will be documented and executed jointly by the NCTA and the Design-Build Team with a copy of such being sent to the Design-Build Team's warranty bond surety agent.

Corrective Work

Within seven calendar days of the Design-Build Team's receipt of NCTA's notice specifying a failure of any Work to satisfy Design-Build Team's Warranties, or any Subcontractor representation, warranty, guarantee or obligation for which the Design-Build Team is responsible to enforce, the Design-Build Team and NCTA shall mutually agree when and how the Design-Build Team shall remedy such violation. However, in the case that Immediate Corrective Work is required, as indicated by NCTA in its notice, the Design-Build Team and NCTA shall agree on a remedy immediately upon notice by NCTA of such need for immediate work. No Corrective Work shall occur without NCTA knowledge of such activities or operations.

The NCTA may elect to have the Corrective Work postponed within the warranty term to minimize traffic disruption provided such Corrective Work poses no safety issues to motorists.

If the Design-Build Team does not use its best efforts to proceed to effectuate such remedy within the agreed time, or if the Design-Build Team and NCTA fail to reach such an agreement within such seven calendar day period (or immediately, in the case of Immediate Corrective Work), then NCTA, after notice to the Design-Build Team, shall have the right to perform or have performed by third parties the necessary remedy, and all costs thereof shall be borne by the Design-Build Team.

Requirements originally developed and detailed in the Contract shall apply throughout the warranty term and to all Corrective Work, including lane closure time restrictions and associated liquidated damages. The Design-Build Team shall be responsible for payment, to NCTA, of any liquidated damages incurred during the warranty term resulting from lane closures within the restricted times as detailed in the Contract. If lane closures are required during restricted times to perform Immediate Corrective Work, then the associated liquidated damages shall apply.

The Design-Build Team shall be responsible for obtaining any required permits, approvals or other consents in connection with the Corrective Work.

Warranty of Corrective Work

The Warranties as to each redone, repaired, corrected or replaced element of the Work shall extend beyond the original warranty period, if necessary, to provide at least a one-year warranty period following acceptance of such Corrective Work thereof by NCTA and acceptance thereof by the appropriate owner.

Subcontractor Warranties

Assignment

Without in any way derogating the Design-Build Team's own representations and warranties and other obligations with respect to all of the Work, the Design-Build Team shall obtain from all Subcontractors and cause to be extended to NCTA, appropriate representations, warranties, guarantees and obligations with respect to the design, materials, workmanship, equipment, tools and supplies furnished by such subcontractor. All representations, warranties, guarantees and obligations of subcontractors shall be written so as to survive all NCTA and Design-Build Team inspections, tests and approvals, and shall run directly to and be enforceable by the Design-Build Team and/or NCTA, including their respective successors and assigns. The Design-Build Team hereby assigns to NCTA all of the Design-Build Team's rights and interest in all extended warranties for periods exceeding the applicable three year Warranty Term (including extensions thereof under the section "Warranty of Corrective Work" included in this provision.), which are received by the Design-Build Team from any of its subcontractors, suppliers or manufacturers.

Enforcement

Upon receipt from NCTA of notice of a failure, to perform Corrective Work needed to satisfy any subcontractor, supplier or manufacturer warranty, representation, guarantee, or obligation, the Design-Build Team shall enforce or perform any such representation, warranty, guarantee or obligation, in addition to Design-Build Team's other obligations hereunder. NCTA's rights under this section, shall commence at the time such representation, warranty, guarantee or obligation is furnished or at the Substantial Completion, whichever is earlier, and shall continue until the expiration of Design-Build Team's relevant warranty term (including extensions thereof under the section "Warranty of Corrective Work" included in this provision). Until such expiration, the Design-Build Team shall be responsible for the cost of any equipment, material, labor (including re-engineering) or shipping, and the Design-Build Team shall be required to replace or repair defective equipment, material or workmanship furnished by any subcontractor, supplier or manufacturer.

No Limitation of Liability

The foregoing warranties are in addition to all rights and remedies available under the Contract or applicable law, and shall not limit the Design-Build Team's liability or responsibility imposed by the Contract or applicable law with respect to the Work, including liability for design defects, latent construction defects, strict liability, negligence or fraud.

Warranty Beneficiaries

In addition to benefiting NCTA and its successors and assigns, the Warranties and subcontractor warranties provided under the "Initial Project Acceptance" section included in this provision, shall inure to the benefit of, and shall be directly enforceable by the NCTA and Utility Owners with respect to those portions of the Work owned or controlled by each such owner.

Remedies for Breach of Warranty

It is the NCTA's intent to reserve the right to recover any and all actual damages, not subject to liquidated damages, resulting from any breach of an express or implied warranty or any defect in the Work.

Disputes

Any disagreement between NCTA and the Design-Build Team relating to this warranty provision shall be subject to the Dispute Review Board provisions contained in the Contract and Article 104-8(B) of the *Standard Specifications* provided that Design-Build Team shall proceed as directed by NCTA pending resolution of the dispute.

Should disputed Corrective Work pose a safety issue to the motorist, the NCTA may (1) direct the Design-Build Team to perform the Corrective Work with costs being documented in accordance with Article 109-3 of the *Standard Specifications*; or (2) after notice to the Design-Build Team, the NCTA shall have the right to perform or have performed by third parties the necessary remedy, and all costs thereof shall be borne by responsible party upon resolution of the dispute.

Rights and Responsibilities of the NCTA

The NCTA:

- A. Reserves the right to approve the schedule proposed by the Design-Build Team to perform warranty work.
- B. Reserves the right to approve all materials and specifications used in warranty work.
- C. Reserves the right to determine if warranty work performed by the Design-Build Team meets the contract specifications.
- D. Reserves the right to perform, or have performed, routine maintenance during the warranty period, which routine maintenance will not diminish the Design-Build Team's responsibility under the warranty.
- E. Reserves the right, if the Design-Build Team is unable, to perform Immediate Corrective Work to the pavement to prevent an unsafe road condition as determined by the NCTA. The NCTA will attempt to notify the Design-Build Team that work is required to address an unsafe condition. However, should the Design-Build Team be unable to comply with this requirement, to the NCTA's satisfaction and within the time frame required by the NCTA, the NCTA will perform, or have performed any Immediate Corrective Work deemed necessary. Any such Immediate Corrective Work undertaken will not relieve the Design-Build Team from meeting the warranty requirements of this Provision. Any costs associated with the Immediate Corrective Work will be paid by the Design-Build Team if it is determined the cause was from defective materials and/or workmanship.
- F. Is responsible for notifying the Design-Build Team, in writing, of any Corrective Work required to meet the warranty requirements.
- H. Is responsible for the costs associated with CEI for the identification of the need for Corrective Work (or Immediate Corrective Work) and performance of Corrective Work (or Immediate Corrective Work).

Rights and Responsibilities of the Design-Build Team.

The Design-Build Team:

- A. Shall warrant to the NCTA that the warranted work will be free of defects in materials and workmanship. The warranty bond shall be submitted to the NCTA as a prerequisite of the NCTA determining the project Substantially Complete.
- B. Shall be responsible for performing all Corrective Work including, but not limited to, maintaining traffic and restoring all associated pavement features, at the Design-Build Team's expense. Liquidated Damages established in the Contract Documents will be in effect if the proposed traffic plan for Corrective Work requires lane closures during restricted times.

- C Shall be responsible for performing all Corrective Work resulting from being in non-compliance with the warranty requirements, using NCTA approved materials and methods.
- D. Shall be responsible for performing Corrective Work upon NCTA specifying a failure of any Work to satisfy Design-Build Team's Warranties, unless otherwise directed.
- E. Shall notify the NCTA and submit a written course of action for performing the needed Corrective Work a minimum of seven calendar days prior to commencement of Corrective Work, except in the case of Immediate Corrective Work as detailed in this special provision. The submittal must propose a schedule for performing the Corrective Work and the materials and methods to be used.
- F Shall submit a traffic control plan and have said plan approved by the NCTA prior to performing Corrective Work and shall adhere to that plan while performing the work.
- G. Shall complete all Corrective Work prior to conclusion of the warranty period, or as otherwise agreed to by the NCTA.
- H. Shall be liable during the warranty period in the same manner as Design-Build Teams are currently liable for their construction related activities with the NCTA pursuant to the NCDOT 2018 *Standard Specification for Roads and Structures* and the Standard Special Provisions, *Division One*, as included elsewhere in the RFP. This liability shall arise and continue only during the period when the Design-Build Team is performing Corrective Work. This liability is in addition to the Design-Build Team performing and/or paying for any required Corrective Work, and shall include liability for injuries and/ or damages and any expenses resulting therefrom which are not attributable to normal wear and tear of traffic and weather, but are due to non-compliant materials, faulty workmanship, and to the operations of the Design-Build Team.

Non-Extension of Contract

This Provision shall not be construed as extending or otherwise affecting the claim process and statute of limitation applicable to this Contract.

Measurement and Payment

All costs associated with this warranty provision, regardless of when such costs are incurred throughout the warranty term of any extensions as provided in the "Warranty of Corrective Work" section included in this provision, shall be included in the lump sum price bid for the project. These costs include but are not limited to, all bonding, engineering, Corrective Work, traffic control, additional testing and inspections, materials, labor and equipment and incidentals necessary to complete and fulfill the requirements herein of this Contract.

The Design-Build Team shall reimburse NCTA for any expenses made necessary by any Corrective Work. Payment shall be provided within 10 Days after the Design-Build Team's receipt of invoice.

PROJECT WARRANTY

Design-Build Team warrants that:

- A. the Work, as completed for the Project, meets all of the requirements of the Contract Documents;
- B. the Plans, details and/or drawings selected or prepared for use during construction are appropriate for their intended use;
- C. all Plans furnished pursuant to the Contract conform to all professional engineering principles generally accepted as standards of the industry in North Carolina;
- D. all Work is performed in accordance with the Released for Construction plans;
- E. all Work is in reasonably close conformity with the lines, grades, cross sections, dimensions, and material requirements, including tolerances shown in the contract, unless otherwise documented in a mutually agreeable executed agreement between the NCTA and the Design-Build Team which details the acceptance of the Work in accordance with Article 105-3 of the *Standard Specifications* as amended by the Standard Special Provisions, *Division One*, included elsewhere in this RFP.

No price adjustment or payment made in connection with acceptance of materials or Work pursuant to the Contract or any agreement between the Design-Build Team and NCTA to accept Work, which is not in close conformity, shall in any manner, excuse, waive, impair or negate the warranties described herein or the Design Build Team's obligation or responsibility for such warranties.

This warranty provision shall in no way relieve the requirement for the initial Work to meet the requirements of the Contract Documents prior to final acceptance.

- F. all materials and equipment furnished under the Contract are of good quality and, when installed, are new;
- G. all materials, as installed, are suitable for their intended use with appropriate testing conducted to ensure the materials meets or exceeds requirements of the design as approved by the Engineer of Record, provided all requirements of the Contract are met.

MATERIALS & WORKMANSHIP PAVEMENT WARRANTY

Description.

The materials and workmanship pavement warranty shall consist of the warranty bond contained in the "Warranty Bond" section and the terms of this Provision. The warranty criteria presented herein contain information unique to each pavement type and appropriate fix.

Materials & Workmanship Warranty

The Design-Build Team is responsible for correcting defects in the pavement caused by elements within the Design-Build Team's control (i.e., the materials supplied and the workmanship), during the warranty term. Since the NCTA is responsible for the pavement design, the Design-Build Team assumes no responsibility for defects that are design related. If a defect is attributable to both, the materials and/or workmanship and the design, responsibility for correcting the defect shall be shared by the NCTA and the Design-Build Team; the Design-Build Team is responsible for the percentage of fault attributable to the materials and/or workmanship and the NCTA is responsible for the percentage of fault attributable to the design. However, if the Design-Build Team incorporates an approved ATC pavement design, then the Design-Build Team also assumes responsibility for any defects that are design related.

During the warranty period, the Design-Build Team will not be held responsible for pavement distresses that are caused by factors unrelated to materials and workmanship. These include, but are not limited to: chemical and fuel spills, vehicle fires, snow plowing, and quality assurance testing such as coring. Other factors considered to be beyond the control of the Design-Build Team which may contribute to pavement distress will be considered by the Engineer on a case-by-case basis upon receipt of a written request from the Design-Build Team.

Evaluation Method.

Pavement evaluations shall be conducted by dividing the project into segments. Each individual Travel Lane will be divided into segments of 528 feet (1/10 mile) in length for measuring and quantifying the condition parameters.

Travel Lane(s) - The delineated pavement surface used by traffic. The Travel Lanes shall be the portion of the pavement considered warranted work. Each of the following is considered a separate Travel Lane:

1. Each individual mainline or -Y- line lane, for each direction of travel.
2. The sum of all ramps, loops, and the associated acceleration/deceleration lanes are considered a separate Travel Lane.
3. The sum of all auxiliary lanes, such as passing and turn lanes is considered a separate Travel Lane.

Approaches, driveways, shoulders and adjoining transition tapers between various types of pavement are not considered Travel Lanes or addressed under this Section; however, shall be warranted under the "Project Warranty" section, included in this provision.

The beginning point of the initial segment layout will be the Point of Beginning (POB) of the project or construction limits for -Y- lines. Segments will be laid out consecutively to the Point of Ending (POE) of the project. The original segmentation of the project will be used for all successive reviews throughout the warranty period.

Warranty Requirements.

Corrective Work will be required when the threshold limit for any condition parameter, as detailed in the sections below, is exceeded as a result of a defect in materials and/or workmanship.

To determine whether the failure to meet the warranty requirements is a result of defects in materials and/or workmanship, a joint field investigation by the NCTA and the Design-Build Team will be conducted. The NCTA or Design-Build Team may elect to have a forensic investigation conducted. The decision to undertake a forensic investigation, the scope of it, and the selection of the party to conduct it will be agreed to by the NCTA and the Design-Build Team. The forensic investigation will be conducted by a qualified entity and at an AASHTO certified laboratory with the results being final and binding. If an agreement cannot be reached, a Dispute Review Board (DRB) may be convened in accordance with the Contract. The DRB will then decide the need for a forensic investigation, its scope and the party to conduct the investigation. All costs related to the forensic investigation will be shared proportionately between the Design-Build Team and the NCTA based on the determined cause of the pavement problem.

WARRANTY CRITERIA FOR NEW HOT MIX ASPHALT PAVEMENT

Application.

This section applies to all components of a multiple lift Hot Mix Asphalt (HMA) pavement structure placed on stabilized soil or aggregate base course. This section excludes any resurfacing, permeable base course, or partial width (less than 10 feet in width) widening of existing facilities; however, the section “Project Warranty” detailed above shall apply to such asphalt pavement.

Limits of Warranted Work

The warranted work includes all components of a multiple lift hot mix asphalt pavement placed for Travel Lanes and shoulders within the project limits, including -Y- lines.

Condition Parameters and Threshold Limit

Condition parameters are used to measure the performance of the HMA pavement during the warranty term. Each condition parameter has a threshold limit applied at which time Corrective Work is required.

- A. Transverse Crack** - A crack, at least five feet in length that is oriented primarily in the transverse direction versus the longitudinal direction. That is, the angle between the overall crack line and the transverse line is less than 45 degrees. It can be either straight or irregular.
- B. Longitudinal Crack/Open Joint** - A crack or open joint, at least five feet in length that is oriented primarily in the longitudinal direction versus the transverse direction. That is, the angle between the overall crack line and the centerline is less than 45 degrees. It can exist anywhere in the Travel Lane; i.e., at the pavement centerline joint, wheel path, center of lane, or lane/shoulder joint.

- C. De-bonding** - A physical separation of two HMA layers. De-bonding will be visually identified as shoving, or the loss of the new surface course. Surface potholes, regardless of depth, will be classified as de-bonding.
- D Raveling** - Surface disintegration, due to the loss of coarse or fine aggregate material, that occurs over an area or in a continuous longitudinal strip.
- E. Flushing** - The accumulation of excess asphalt binder on the pavement surface that creates a shiny, reflective condition and becomes tacky to the touch at high temperatures.
- F. Rutting** - A longitudinal surface depression in the wheel path. It may have associated transverse displacement or bulging.
- F. Alligator Cracking** - Parallel longitudinal cracks with transverse tears between them exhibiting a pattern similar to an alligator hide. An Alligator Crack typically starts in a wheel path and may extend to other lane locations.
- G. Block Cracking** - Transverse and longitudinal cracking that has progressed to a pattern that the pavement is broken into blocks of size less than 12" by 12". The shape of each block may be irregular.
- H. Popout** - A small piece of pavement, aggregate, or debris greater than 0.25 inch in diameter that has broken loose from the surface.
- J. Ride Quality/Pavement Smoothness** - Measurement of pavement roughness to establish appropriate ride comfort levels for the motorist on the facility.
- K. Skid Resistance** - the force developed when a tire that is prevented from rotating slides along the pavement surface as tested in accordance with ASTM E274-90.

Warranty Criteria and Recommended Corrective Work

The table below lists the allowable threshold limit for each condition parameter at which time Corrective Work is required, unless otherwise directed.

The Corrective Work detailed is recommended to outline typical acceptable treatments for the various condition parameters. The NCTA will accept the listed Corrective Work if the work addresses the cause of the condition parameter. The Design-Build Team may use an alternative action subject to NCTA approval. The limits of the Corrective Work shall be approved by NCTA and may include areas that are immediately adjacent to the pavement defect; however, not currently demonstrating defects or the condition parameters detailed above. Any hot mix asphalt requiring removal/replacement to correct deficiencies, for any condition parameter, shall be replaced full-width across the lane.

HOT MIX ASPHALT WARRANTY REQUIREMENTS		
CONDITION PARAMETER	THRESHOLD LIMIT PER SEGMENT ⁽¹⁾ (Length = 528 feet Width = 12 feet)	RECOMMENDED CORRECTIVE WORK
Transverse Cracking	Any transverse crack measuring ≥ 6 feet	Cut and seal
Longitudinal Cracking/ Open Joint	Any longitudinal crack measuring ≥ 25 feet	Cut and seal
Alligator Cracking ⁷ (Minor)	0 to 4% of segment area	Saw and patch or mill and Resurface affected courses
Alligator Cracking (Major)	$\geq 4\%$ of segment area	Mill and resurface affected courses to include subgrade or base repair
Block Cracking ⁽⁷⁾ (Minor)	0 to 4% of segment area	Saw and patch or mill and resurface affected courses
Block Cracking (Major)	$\geq 4\%$ of segment area	Mill and resurface affected courses to include subgrade or base repair
De-bonding ⁽⁷⁾ (Minor)	0 to 2% of segment area	Saw and patch or mill and resurface affected courses
De-bonding (Major)	$\geq 2\%$ of segment area	Mill and Resurface affected courses
Raveling	$\geq 8\%$ of segment area	Mill and Resurface affected courses
Flushing	$\geq 4\%$ of segment area	Mill and Resurface affected courses
Rutting ⁽³⁾	25% of segment length having an avg. rut depth $\geq 3/8$ inch ⁽²⁾	Mill and Resurface ⁽⁶⁾
Popout	25 individual popouts in segment	Mill and Resurface affected courses
Ride Quality (IRI)	≥ 75 ⁽⁴⁾	Mill, overlay or replace to bring back to within threshold limit
Skid Resistance	≥ 37 ⁽⁵⁾	Mill and Resurface ⁽⁶⁾ to bring back within threshold limit.
<p>(1) Warranty Corrective Work is required upon documentation of the threshold limit being met or exceeded</p> <p>(2) The rut depth threshold applies to each wheel path independently.</p> <p>(3) The pavement surface will be evaluated for the presence of rutting on each driving lane throughout the warranty period. Measurement will be made using a high-speed electronic profilometer. These measurements may be confirmed using a straight rigid device that is a minimum of 7 feet long and of sufficient stiffness that it will not deflect from its own weight.</p>		

- (4) The pavement surface will be evaluated for ride quality in each wheel path. IRI measurement will be an average of the left and right wheel paths.
- (5) Skid Number as measured with a locked wheel tester
- (6) Recommended action is dependent on the depth of the rut susceptible material.
- (7) All alligator cracking, block cracking and debonding are symptomatic of premature pavement failure and require Corrective Work.

WARRANTY CRITERIA FOR NEW JOINTED PORTLAND CEMENT CONCRETE PAVEMENT

Application

This section applies to all components within and the combination thereof to construct new jointed portland cement concrete pavement placed on hot mix asphalt or aggregate base course.

Limits of Warranted Work

The warranted work includes all jointed Portland cement concrete pavement placed for Travel Lanes and shoulders within the project limits.

Condition Parameters and Threshold Limit

Condition parameters are used to measure the performance of the concrete pavement during the warranty term. Each condition parameter has a threshold limit applied at which time Corrective Work is required.

- A. Crack** - A visible fissure or surface discontinuity that may or may not extend through the entire slab. Cracks may be singular or in multiple patterns. Crack types are:
 1. **Transverse** - A crack, at least five feet in length that is oriented primarily in the transverse direction versus the longitudinal direction. That is, the angle between the overall crack line and the transverse line is less than 45 degrees. It can be either straight or irregular.
 2. **Longitudinal** - A crack, at least five feet in length that is oriented primarily in the longitudinal direction versus the transverse direction. That is, the angle between the overall crack line and the centerline is less than 45 degrees. It can exist anywhere in the Travel Lane or shoulder; i.e., at the pavement centerline joint, wheel path, center of lane, or lane/shoulder joint.
 3. **Corner** – A crack with orientation generally diagonal and located near a slab corner. It typically intersects both the transverse and longitudinal pavement joints.
 4. **Map** - Interconnecting, variable spaced cracks in a random orientation and pattern.
 5. **Shrinkage** - A small crack or cracks produced by the loss of contained water during the dehydration process.

- B. Spalling** - Broken or missing piece of concrete contiguous with the perimeter edge of a slab with a surface area exceeding two square inches.
- C. Joint Sealant Failure** - The loss of material integrity consisting of either adhesive failure (debonding), cohesive failure (material separation), or the complete loss of sealant material.
- D. Shattered Slab** - A pavement slab broken into four or more sections by full-depth cracks.
- E. Scaling** - The concrete surface has a visible, exposed, rough texture from a loss of either aggregate or mortar.
- F. Non-functionong Joint** – Joints or areas within 4 feet of the joint showing distresses including faulting, pumping, spalling, cracking, blowups, and mid-panel cracking or inadequate load transfer.
- G. Ride Quality/Pavement Smoothness** - Measurement of pavement roughness to establish appropriate ride comfort levels for the motorist on the facility.
- H. Skid Resistance** - The force developed when a tire that is prevented from rotating slides along the pavement surface as tested in accordance with ASTM E274-90.

Warranty Criteria and Recommended Corrective Work

The table below lists the allowable threshold limit for each condition parameter at which time Corrective Work is required, unless otherwise directed.

The Corrective Work detailed is recommended to outline typical acceptable treatments for the various condition parameters. The NCTA will accept the listed Corrective Work if the work addresses the cause of the condition parameter. The Design-Build Team may use an alternative action subject to NCTA approval. The limits of the Corrective Work shall be approved by NCTA and may include areas that are immediately adjacent to the pavement defect; however, not currently demonstrating defects or the condition parameters detailed above. Concrete Pavement requiring removal/replacement to correct deficiencies, for any condition parameter, may require the pavement to be replaced full-width across the lane and minimum length of 6 feet to ensure long term durability. NCTA will determine if such full width removal is necessary; however a patch greater than 4 feet in length is typically the maximum allowed prior to patching full width.

PORTLAND CEMENT CONCRETE PAVEMENT WARRANTY REQUIREMENTS		
CONDITION PARAMETER	THRESHOLD LIMITS PER SEGMENT ⁽¹⁾ (Length = 528 feet)	RECOMMENDED CORRECTIVE WORK ^{(7) (13)}
Transverse Cracking	Any transverse crack measuring \geq 6 feet	Remove and replace slab ^{(8) (9)}
Longitudinal Cracking	Any longitudinal crack measuring \geq 8 feet	Remove and replace slab ^{(8) (9)}
Corner Cracking	\geq 3 corner cracks within segment	Repair with elastomeric conc. ⁽¹⁰⁾
Map Cracking	\geq 5% of segment area	Remove and replace slab ⁽⁹⁾
Shrinkage Cracking	\geq 5% of segment area	Remove and replace slab ⁽⁸⁾
Spalling	\geq 10% of a single 15 slab ⁽²⁾ and \leq 5 slabs requiring repair ⁽¹⁴⁾	Repair with elastomeric concrete ⁽¹⁰⁾
Joint Sealant Failure	\geq 10% joint length ⁽³⁾ and \leq 4 slabs requiring repair	Remove and replace seal material ⁽¹²⁾
Shattered Slab ⁽⁴⁾	Any shattered slab shall be replaced	Full depth removal of slab and replacement
Scaling	\geq 25% of the slab area \leq 3 slabs within segment	Diamond grind surface ⁽¹¹⁾ or remove and replace
Nonfunctioning Joint(s)	\geq 3 Non-consecutive joints ⁽¹⁵⁾	Remove pavement full depth a minimum 6 feet either side of joint and replace slab and joint
Ride Quality (IRI)	\geq 70 ⁽⁵⁾	Diamond grind ⁽¹¹⁾ , or replace to bring back to within threshold limit
Skid Resistance	\geq 37 ⁽⁶⁾	Diamond Grind affected area ⁽¹¹⁾
<p>(1) Warranty Corrective Work is required upon documentation of the threshold limit being met or exceeded.</p> <p>(2) Can be non-contiguous. 10% value applies to total perimeter (four sides) of the slab.</p> <p>(3) Applies to all transverse and longitudinal joints on the perimeter of the slab. Noncontiguous lengths will be summed on a per slab basis.</p> <p>(4) Shattered slabs will not be an acceptable condition, and shall be removed and replaced as approved by the Engineer.</p> <p>(5) The pavement surface will be evaluated for ride quality in each wheel path. IRI measurement will be an average of the left and right wheel paths.</p> <p>(6) Skid Number as measured with a locked wheel tester</p> <p>(7) If multiple condition parameters are present, the recommended action may be revised. Removal and replacement is required if multiple crack types are present.</p> <p>(8) The appropriate corrective treatment is dependent on the crack's location and depth.</p> <p>(9) Dependent on cause.</p>		

- (10) Repair dependent on area and depth of crack.
- (11) Diamond grinding applies to entire slab surface area where corrective action is needed.
- (12) Replace with existing material type. Neoprene seals shall be removed and replaced full-width.
- (13) All Corrective Work shall be conducted in accordance with the most current procedures and material mixtures recommended by NCDOT Portland Cement Concrete Pavement Repair Manual, unless otherwise approved.
- (14) Excessive spall repair throughout the segment may necessitate more substantial repairs to include full depth slab replacement.
- (15) Evaluate all joints within defective segment with the MIT Scan. Repairs will be based upon dowel placement and functioning joints within segment.

WARRANTY CRITERIA FOR BRIDGE COMPONENTS

Application

This section applies to the Bridge Deck Surface, Bridge Deck Joints, Bearings, Approach Slab Transitions, and the individual components of such items used in the construction of the Project.

Limits of Warranted Work

The warranted work includes all bridges constructed and/or widened as part of this Project.

Bridge Deck

Condition Parameters and Threshold Limit

Condition parameters are used to measure the performance of the bridge components during the warranty term. Each condition parameter has a Threshold Limit applied at which time Corrective Work is required

- A. Spalling** - Broken or missing piece of concrete with a surface area exceeding two square inches.
- B. Scaling** - The concrete surface has a visible, exposed, rough texture from a loss of either aggregate or mortar.
- C. Crack** - A visible fissure or surface discontinuity that may or may not extend through the entire slab. Cracks may be singular or in multiple patterns. A map crack is defined as interconnecting, variable spaced cracks in a random orientation and pattern.
- D. Skid Resistance** - The force developed when a tire that is prevented from rotating slides along the pavement surface

Warranty Criteria and Recommended Corrective Work

The table below lists the allowable threshold limit for each condition parameter at which time Corrective Work is required, unless otherwise directed.

The Corrective Work detailed is recommended to outline typical acceptable treatments for the various condition parameters. The NCTA will accept the listed Corrective Work if the work addresses the cause of the condition parameter. The Design-Build Team may use an alternative action subject to NCTA approval. The limits of the Corrective Work shall be approved by NCTA and may include areas that are immediately adjacent to the pavement defect; however, not currently demonstrating defects or the condition parameters detailed above.

Listed are the parameters when bridge components are considered defective within the warranty term.

BRIDGE DECK WARRANTY REQUIREMENTS		
CONDITION PARAMETER	THRESHOLD LIMITS (PER INDIVIDUAL BRIDGE) ⁽¹⁾	RECOMMENDED CORRECTIVE WORK ⁽²⁾⁽³⁾
Deck Scaling (Less than 1/4" deep but greater than 1/8" deep)	≥ 20% of the individual bridge deck surface area	Grind all affected spans; saw cut transverse grooves; seal surface with an approved sealing agent
Deck Scaling (Greater than 1/4")	≥ 20% of the individual bridge deck surface area	Mill or hydrodemolish a minimum of 1 inch deep or to sound concrete and patch with a latex modified concrete
Spalling (Minor)	Repair spalling ≤ 1/2" deep or ≤ 1 square foot	Perform a Class II repair a minimum depth of 3/4" below the top mat of rebar and repair with concrete or a non-shrink grout as directed by the Engineer.
Spalling (Major)	Repair spalling > 1/2" deep or > 1 square foot	Perform a Class II repair a minimum depth of 3/4" below the top mat of rebar and repair with concrete or a non-shrink grout as directed by the Engineer.
Cracking (Map cracking)	5% to 20% of deck surface	Seal surface with an approved sealing agent
Cracking (Map cracking)	Greater than 20% of deck	Mill or Hydro demolition a minimum 1" deep or to sound concrete; repair with latex modified concrete
Skid Resistance	≥ 37	Diamond grind, or otherwise scarify the deck to bring back within threshold limit.

- (1) Warranty Corrective Work is required upon documentation of the threshold limit being met or exceeded
- (2) Repairs are dependant upon size, depth and cause; therefore, all corrective work shall be approved by NCTA
- (3) If amount of deck repair exceeds 40% of deck surface area, then corrective work shall be performed to entire deck area, unless otherwise directed.

Bridge Deck Joints

Bridge Deck Joints shall include all components of the joint and joint system to include any protective armoring. Bridge deck joints will be considered defective if any of the following conditions are discovered within the warranty term and shall require Corrective Work.

- A. Water leakage through the joint;
- B. Separation of the seal from the steel or concrete substrate or side of slab;
- C. Failure of bridge deck joint;
- D. Sagging of elastomeric seal;
- E. Spalling or delamination of the deck concrete within two feet, either side of the joint.

Corrective Work Required – Defective bridge deck joints shall be restored to a “new condition”, meeting the original contract and design requirements, in a manner approved by the NCTA.

Bridge Bearings

Bearings shall be considered defective if any of the following conditions are discovered within the warranty term.

- A. There is evidence of failure of any of the components of the bearing assembly;
- B. The protective coating of the bearing cracks, checks or peels or rusting is present; or
- C. The bearing freezes or otherwise fails to allow the bridge to move as designed.

Corrective Work Required - Bearings shall be removed and either replaced or restored to “new condition,” meeting the original contract and design requirements, in a manner approved by the NCTA.

Bridge Approach Transition

Bridge Approach Transitions shall be defined as the transition from the roadway pavement onto the bridge approach slab, and shall include the bridge approach slab and adjacent roadway pavement. The Bridge Approach Transition shall be considered defective when the distance as measured with a 10 foot straightedge deviates from a planar surface by more than ½ inch.

Corrective Work Required- Diamond grind, overlay (for Hot Mix Asphalt Pavements), grout, or remove and replace the pavement and or the bridge approach slab, as approved by NCTA, to bring the bridge approach transition back to within the ½ inch tolerance.

PERMANENT VEGETATION ESTABLISHMENT

(6-11-15) (Rev. 8-30-17)

104

DB01 G160

Establish permanent vegetation stands of the Long Term Stabilization mixtures identified in the Erosion and Sedimentation Control Scope of Work found elsewhere in this RFP. During the period between initial vegetation planting and final project acceptance, perform all work necessary to establish 80% coverage of permanent vegetation within the project limits, as well as, in borrow and waste pits. This work shall include erosion control device maintenance and installation, repair seeding and mulching, supplemental seeding and mulching, mowing, and fertilizer topdressing, as directed. All work shall be performed in accordance with the Erosion and Sedimentation Control Scope of Work and the applicable sections of the 2018 *Standard Specifications for Roads and Structures*.

Once the Engineer has determined that 80% coverage of permanent vegetation has been established, the Design-Build Team will be notified to remove the remaining erosion control devices that are no longer needed. The Design-Build Team shall be responsible for, and shall correct, any areas disturbed by operations performed in permanent vegetation establishment and the removal of temporary erosion control measures, whether occurring prior to or after placing traffic on the project.

EROSION & SEDIMENT CONTROL / STORMWATER CERTIFICATION

(1-16-07) (Rev. 9-20-16)

105-16, 225-2, 16

DB1 G180

General

Schedule and conduct construction activities in a manner that will minimize soil erosion and the resulting sedimentation and turbidity of surface waters. Comply with the requirements herein regardless of whether or not a National Pollutant Discharge Elimination System (NPDES) permit for the work is required.

Establish a chain of responsibility for operations and subcontractors' operations to ensure that the *Erosion and Sediment Control / Stormwater Pollution Prevention Plan* is implemented and maintained over the life of the contract.

- (A) *Certified Supervisor* – Provide a certified Erosion and Sediment Control / Stormwater (E&SC/SW) Supervisor to manage the Design-Build Team and subcontractor(s) operations, ensure compliance with Federal, State and Local ordinances and regulations, and manage the Quality Control Program.
- (B) *Certified Foreman* – Provide a certified, trained foreman for each construction operation that increases the potential for soil erosion or the possible sedimentation and turbidity of surface waters.
- (C) *Certified Installer* – Provide a certified installer to install or direct the installation for erosion or sediment / stormwater control practices.

- (D) *Certified Designer* – Provide a certified designer for the design of the erosion and sediment control / stormwater component of reclamation plans and, if applicable, for the design of the project erosion and sediment control / stormwater plan.

Roles and Responsibilities

- (A) *Certified Erosion and Sediment Control / Stormwater Supervisor* - The Certified Supervisor shall be Level II and shall be responsible for ensuring the erosion and sediment control / stormwater plan is adequately implemented and maintained on the project and for conducting the quality control program. The Certified Supervisor shall be on the project within 24 hours notice from initial exposure of an erodible surface to the project's final acceptance. The Certified Supervisor shall perform the following duties:
- (1) **Manage Operations** - Coordinate and schedule the work of subcontractors so that erosion and sediment control / stormwater measures are fully executed for each operation and in a timely manner over the duration of the contract.
 - (a) Oversee the work of subcontractors so that appropriate erosion and sediment control / stormwater preventive measures are conformed to at each stage of the work.
 - (b) Prepare the required National Pollutant Discharge Elimination System (NPDES) Inspection Record and submit to the Engineer.
 - (c) Attend all weekly or monthly construction meetings to discuss the findings of the NPDES inspection and other related issues.
 - (d) Implement the erosion and sediment control / stormwater site plans requested.
 - (e) Provide any needed erosion and sediment control / stormwater practices for the Design-Build Team's temporary work not shown on the plans developed by the Design-Build Team, such as, but not limited to work platforms, temporary construction, pumping operations, plant and storage yards, and cofferdams.
 - (f) Acquire applicable permits and comply with requirements for borrow pits, dewatering, and any temporary work conducted by the Design-Build Team in jurisdictional areas.
 - (g) Conduct all erosion and sediment control / stormwater work in a timely and workmanlike manner.
 - (h) Fully perform and install erosion and sediment control / stormwater work prior to any suspension of the work.
 - (i) Coordinate with Department, Federal, State and Local Regulatory agencies on resolution of erosion and sediment control / stormwater issues due to the Design-Build Team's operations.
 - (j) Ensure that proper cleanup occurs from vehicle tracking on paved surfaces and / or any location where sediment leaves the right of way.
 - (k) Have available a set of erosion and sediment control / stormwater plans that are initialed and include the installation date of Best Management Practices. These practices shall include temporary and permanent groundcover and be

properly updated to reflect necessary plan and field changes for use and review by Department personnel, as well as regulatory agencies.

- (2) Requirements set forth under the NPDES Permit – The Department's NPDES Stormwater Permit (NCS000250) outlines certain objectives and management measures pertaining to construction activities. The permit references *NCG010000, General Permit to Discharge Stormwater* under the NPDES, and states that the Department shall incorporate the applicable requirements into its delegated Erosion and Sediment Control Program for construction activities disturbing one or more acres of land. The Department further incorporates these requirements on all contracted bridge and culvert work at jurisdictional waters, regardless of size. Some of the requirements shall be, but are not limited to:
 - (a) Control project site waste to prevent contamination of surface or ground waters of the state, e.g. from equipment operations / maintenance construction materials, concrete washout, chemicals, litter, fuels, lubricants, coolants, hydraulic fluids, any other petroleum products, and sanitary waste.
 - (b) Inspect erosion and sediment control / stormwater devices and stormwater discharge outfalls at least once every 7 calendar days, and within 24 hours after a rainfall event of 0.5 inch, or greater, that occurs within a 24-hour period. At the discretion of Division of Water Resources personnel, additional monitoring may be required if the receiving stream is 303(d) listed for turbidity and the project has had documented problems managing turbidity.
 - (c) Maintain an onsite rain gauge or use the Department's Multi-Sensor Precipitation Estimate website to maintain a daily record of rainfall amounts and dates.
 - (d) Maintain erosion and sediment control / stormwater inspection records for review by Department and Regulatory personnel upon request.
 - (e) Implement approved reclamation plans on all borrow pits, waste sites and staging areas.
 - (f) Maintain a log of turbidity test results as outlined in the Department's Procedure for Monitoring Borrow Pit Discharge.
 - (g) Provide secondary containment for bulk storage of liquid materials.
 - (h) Provide training for employees concerning general erosion and sediment control / stormwater awareness, the Department's NPDES Stormwater Permit NCS000250 requirements, and the applicable requirements of the *General Permit, NCG010000*.
 - (i) Report violations of the NPDES Permit to the Engineer immediately who will notify the NC Department of Environmental Quality Regional Office within 24 hours of becoming aware of the violation.
- (3) Quality Control Program - Maintain a quality control program to control erosion, prevent sedimentation and follow provisions / conditions of permits. The quality control program shall:

- (a) Follow permit requirements related to the Design-Build Team and subcontractors' construction activities.
 - (b) Ensure that all operators and / or subcontractor(s) on site have the proper erosion and sediment control / stormwater certification.
 - (c) Notify the Engineer when the required certified erosion and sediment control / stormwater personnel are not available on the job site when needed.
 - (d) Conduct the inspections required by the NPDES Permit.
 - (e) Take corrective actions in the proper timeframe as required by the NPDES Permit for problem areas identified during the NPDES inspections.
 - (f) Incorporate erosion control into the work in a timely manner and stabilize disturbed areas with mulch / seed or vegetative cover on a section-by-section basis.
 - (g) Use flocculants approved by state regulatory authorities where appropriate and where required for turbidity and sedimentation reduction.
 - (h) Ensure proper installation and maintenance of temporary erosion and sediment control devices.
 - (i) Remove temporary erosion or sediment control devices when they are no longer necessary as agreed upon by the Engineer.
 - (j) The Design-Build Team's quality control and inspection procedures shall be subject to review by the Engineer. Maintain NPDES inspection records and make records available at all times for verification by the Engineer.
- (B) *Certified Foreman* - At least one Certified Foreman shall be onsite for each type of work listed herein during the respective construction activities to control erosion, prevent sedimentation and follow permit provisions:
- (1) Foreman in charge of grading activities
 - (2) Foreman in charge of bridge or culvert construction over jurisdictional areas
 - (3) Foreman in charge of utility activities

The Design-Build Team may request to use the same person as the Level II Supervisor and Level II Foreman. This person shall be onsite whenever construction activities as described above are taking place. This request shall be approved by the Engineer prior to work beginning.

The Design-Build Team may request to name a single Level II Foreman to oversee multiple construction activities on small bridge or culvert replacement projects. This request shall be approved by the Engineer prior to work beginning.

- (C) *Certified Installers* - Provide at least one onsite, Level I Certified Installer for each of the following erosion and sediment control / stormwater crew:
- (1) Seeding and Mulching
 - (2) Temporary Seeding
 - (3) Temporary Mulching
 - (4) Sodding
 - (5) Silt fence or other perimeter erosion / sediment control device installations
 - (6) Erosion control blanket installation

- (7) Hydraulic tackifier installation
- (8) Turbidity curtain installation
- (9) Rock ditch check / sediment dam installation
- (10) Ditch liner / matting installation
- (11) Inlet protection
- (12) Riprap placement
- (13) Stormwater BMP installations (such as but not limited to level spreaders, retention / detention devices)
- (14) Pipe installations within jurisdictional areas

If a Level I *Certified Installer* is not onsite, the Design-Build Team may substitute a Level II Foreman for a Level I Installer, provided the Level II Foreman is not tasked to another crew requiring Level II Foreman oversight.

- (D) *Certified Designer* – Include the certification number of the Level III-B Certified Designer on the erosion and sediment control / stormwater component of all reclamation plans and if applicable, the certification number of the Level III-A Certified Designer on the design of the project erosion and sediment control / stormwater plan.

Preconstruction Meeting

Furnish the names of the *Certified Erosion and Sediment Control / Stormwater Supervisor*, *Certified Foremen*, *Certified Installers* and *Certified Designers* and notify the Engineer, in writing, of changes in certified personnel over the life of the contract within two days of change.

Ethical Responsibility

Any company performing work for the North Carolina Department of Transportation has the ethical responsibility to fully disclose any reprimand or dismissal of an employee resulting from improper testing or falsification of records.

Revocation or Suspension of Certification

Upon recommendation of the Chief Engineer to the certification entity, certification for Supervisor, Certified Foremen, Certified Installers and Certified Designer may be revoked or suspended with the issuance of an Immediate Corrective Action (ICA), Notice of Violation (NOV), or Cease and Desist Order for erosion and sediment control / stormwater related issues.

The Chief Engineer may recommend suspension or permanent revocation of certification due to the following:

- (A) Failure to adequately perform the duties as defined within this certification provision
- (B) Issuance of an ICA, NOV, or Cease and Desist Order
- (C) Failure to fully perform environmental commitments as detailed within the permit conditions and specifications

- (D) Demonstration of erroneous documentation or reporting techniques
- (E) Cheating or copying another candidate's work on an examination
- (F) Intentional falsification of records
- (G) Directing a subordinate under direct or indirect supervision to perform any of the above actions
- (H) Dismissal from a company for any of the above reasons
- (I) Suspension or revocation of one's certification by another entity

Suspension or revocation of a certification will be sent by certified mail to the certificant and the Corporate Head of the company that employs the certificant.

A certificant has the right to appeal any adverse action which results in suspension or permanent revocation of certification by responding, in writing, to the NCTA Chief Engineer within ten calendar days after receiving notice of the proposed adverse action.

NCTA Chief Engineer
1536 Mail Service Center
Raleigh, NC 27699-1536

Failure to appeal within ten calendar days shall result in the proposed adverse action becoming effective on the date specified on the certified notice. Failure to appeal within the time specified shall result in a waiver of all future appeal rights regarding the adverse action taken. The certificant will not be allowed to perform duties associated with the certification during the appeal process. The Chief Engineer will hear the appeal and make a decision within seven days of hearing the appeal. The decision of the Chief Engineer shall be final and will be made in writing to the certificant.

If a certification is temporarily suspended, the certificant shall pass any applicable written examination and any proficiency examination, at the conclusion of the specified suspension period, prior to having the certification reinstated.

Measurement and Payment

Certified Erosion and Sediment Control / Stormwater Supervisor, Certified Foremen, Certified Installers and Certified Designer will be incidental to the project for which no direct compensation will be made.

PROCEDURE FOR MONITORING BORROW PIT DISCHARGE

(1-22-13) (Rev. 9-7-17)

DB1 G181

Water discharge from borrow pit sites shall not cause surface waters to exceed 50 NTUs (nephelometric turbidity unit) in streams not designated as trout waters and 10 NTUs in streams, lakes or reservoirs designated as trout waters. For lakes and reservoirs not designated as trout waters, the turbidity shall not exceed 25 NTUs. If the turbidity exceeds these levels due to natural background conditions, the existing turbidity level shall not be increased.

If during any operating day, the downstream water quality exceeds the standard, the Design-Build Team shall do all of the following:

- (A) Either cease discharge or modify the discharge volume or turbidity levels to bring the downstream turbidity levels into compliance, or
- (B) Evaluate the upstream conditions to determine if the exceedance of the standard is due to natural background conditions. If the background turbidity measurements exceed the standard, operation of the pit and discharge can continue as long as the stream turbidity levels are not increased due to the discharge.
- (C) Measure and record the turbidity test results (time, date and sampler) at all defined sampling locations 30 minutes after startup and at a minimum, one additional sampling of all sampling locations during that 24-hour period in which the borrow pit is discharging.
- (D) Notify DWR within 24 hours of any stream turbidity standard exceedances that are not brought into compliance.

During the Environmental Assessment required by Article 230-4 of the 2018 *Standard Specifications for Roads and Structures*, the Design-Build Team shall define the point at which the discharge enters into the State's surface waters and the appropriate sampling locations. Sampling locations shall include points upstream and downstream from the point at which the discharge enters these waters. Upstream sampling location shall be located so that it is not influenced by backwater conditions and represents natural background conditions. Downstream sampling location shall be located at the point where complete mixing of the discharge and receiving water has occurred.

The discharge shall be closely monitored when water from the dewatering activities is introduced into jurisdictional wetlands. Any time visible sedimentation (deposition of sediment) on the wetland surface is observed, the dewatering activity will be suspended until turbidity levels in the stilling basin can be reduced to a level where sediment deposition does not occur. Staining of wetland surfaces from suspended clay particles, occurring after evaporation or infiltration, does not constitute sedimentation. No activities shall occur in wetlands that adversely affect the functioning of a wetland. Visible sedimentation will be considered an indication of possible adverse impacts on wetland use.

The Engineer will perform independent turbidity tests on a random basis. These results will be maintained in a log within the project records. Records will include, at a minimum, turbidity test results, time, date and name of sampler. Should the Department's test results exceed those of the Design-Build Team's test results, an immediate test shall be performed jointly with the results superseding the previous test results of both the Department and the Design-Build Team.

To plan, design, construct, and maintain BMPs to address water quality standards, the Design-Build Team shall use the NCDOT *Turbidity Reduction Options for Borrow Pits Matrix*, available at the website noted below:

**[http://connect.ncdot.gov/resources/roadside/FieldOperationsDocuments/
TurbidityReductionOptionSheet.pdf](http://connect.ncdot.gov/resources/roadside/FieldOperationsDocuments/TurbidityReductionOptionSheet.pdf)**

Tier I Methods include stilling basins which are standard compensatory BMPs. Other Tier I methods are noncompensatory and shall be used when needed to meet the stream turbidity standards. Tier II Methods are also noncompensatory and are options that may be needed for protection of rare or unique resources or where special environmental conditions exist at the site which have led to additional requirements being placed in the DWR's 401 Certifications and approval letters, Isolated Wetland Permits, Riparian Buffer Authorization or a DOT Reclamation Plan's Environmental Assessment for the specific site. Should the Design-Build Team exhaust all Tier I Methods on a site exclusive of rare or unique resources or special environmental conditions, Tier II Methods may be required by regulators on a case by case basis per supplemental agreement.

The Design-Build Team may use cation exchange capacity (CEC) values from proposed site borings to plan and develop the Price Proposal for the project. CEC values exceeding 15 milliequivalents per 100 grams of soil may indicate a high potential for turbidity and should be avoided when dewatering into surface water is proposed.

No additional compensation for monitoring borrow pit discharge will be paid.

CLEARING AND GRUBBING

(3-14-08)

DB2 R01

The North Carolina Turnpike Authority is committed to limiting environmental impacts of the project to the extent practicable. Upland forests, which provide habitat for terrestrial wildlife, are instrumental in protecting water and air quality and are one of the natural resources that the NCTA includes in this commitment. For these reasons NCTA is requiring the Design-Build Team to identify and subsequently protect existing upland forests from disturbance within the project right-of-way where feasible. Project safety, constructability and long term project maintenance are not to be compromised in order to implement this commitment. To this end the Design-Build Team shall:

- Identify in the designs the locations where upland trees will be preserved to include quadrants, the median (outside clear recovery zone) and any other locations within the right of way;
- Schedule, coordinate with NCTA, and attend one meeting that may include representatives from the NCTA, FHWA, USEPA, NCDOT, and other agencies to review the recommended areas for upland tree preservation and discuss the methodology for determining these locations. The meeting shall occur prior to beginning land clearing of any section of the project.
- Provide the approach and management plans for implementing the upland forest protection plan in the field with the various contractors and subcontractors;
- Implement the plan such that all project personnel are aware of these upland tree protective zones until the entire project is accepted; and
- Schedule, coordinate with NCTA, and attend additional meetings regarding upland forest preservation areas, if it is determined during construction that conditions have changed such that the upland forest preservation areas identified in the design must be modified.

With the exception of areas with Permanent Utility Easements, perform clearing on this project to the limits established by Method "III" shown on Standard No. 200.03. In areas with Permanent

Utility Easements, clearing shall extend to the Right of Way or easement limits, whichever is greater.

BURNING RESTRICTIONS

(7-1-95)

DB2 R05

Open burning shall not be permitted on any portion of the right of way limits established for this project. The Design-Build Team shall not burn the clearing, grubbing or demolition debris designated for disposal and generated from the project at locations within the project limits, off the project limits or at any waste or borrow sites in Wake or Johnston Counties. The Design-Build Team shall dispose of the clearing, grubbing and demolition debris by means other than burning and in accordance with state and local rules and regulations.

BUILDING AND APPURTENANCE REMOVAL / DEMOLITION

(9-1-11) (Rev. 9-7-17)

DB2 R12B

This Project Special Provision applies only to those parcels that the Design-Build Team is required to acquire, if any, as described in the *Right of Way Scope of Work*.

Unless otherwise as agreed upon by the Department, seal all wells and remove or demolish all buildings and appurtenances, in their entirety, that are located either partially or completely within the project's right of way limits or are located outside the project's right of way limits but within property purchased as an uneconomical remnant in accordance with Sections 205, 210 and 215 of the 2018 *Standard Specifications for Roads and Structures*.

The Department will perform all assessment, removal and disposal of asbestos. Once the Design-Build Team has acquired a parcel and all buildings and appurtenances have been vacated, the Design-Build Team shall immediately notify the Division Right of Way Agent in writing. Upon receipt of the written notification, the Department then requires 60 days to assess and remove any asbestos prior to the Design-Build Team demolishing any building or appurtenance.

In the unlikely event that the Design-Build Team encounters unknown contaminated materials, these materials shall be handled in accordance with Article 107-25 of the 2018 *Standard Specifications for Roads and Structures*.

AUTOMATED MACHINE GUIDANCE (AMG)

(6-17-08)

The requirements contained in Chapter 19 of the *Manual for Construction Layout* apply to this Contract. In addition, the Engineer will perform quality assurance checks of all work associated with AMG. If it is determined that work is not being performed in a manner that will assure accurate results, the Engineer may require corrective action at no cost to the Department.

The Design-Build Team shall provide the Engineer with a GPS rover unit for use during the duration of the contract. The rover shall be loaded with the same model that is used with the AMG and shall have the same capability as rover units used by the Design-Build Team. The rover will be kept in the possession of the Engineer and will be returned to the Design-Build Team upon completion of the contract. Any maintenance or repairs required for the rover shall be the responsibility of the Design-Build Team. Formal training of at least 8 hours on the use of the

proposed AMG system shall be provided to the Engineer by the Design-Build Team and the equipment manufacturer. Training shall include, but not be limited to, hardware, software, and operation of the rover unit.

AUTOMATED FINE GRADING

(9-1-11) (Rev. 9-13-17)

DB5 R05

On mainline portions and ramps of this project, prepare the subgrade and base beneath the pavement structure in accordance with the applicable sections of the 2018 *Standard Specifications for Roads and Structures* except use an automatically controlled fine grading machine utilizing string lines, laser controls, or other approved methods to produce final subgrade and base surfaces meeting the lines, grades, and cross sections required by the plans developed by the Design-Build Team or established by the Engineer.

FINAL SURFACE TESTING

(4-26-16) (Rev. 9-13-17)

DB6 R45

On all mainline travel lanes including, but not limited to, auxiliary lanes, ramps, loops and -Y-Line travel lanes with two or more layers of asphalt and a posted speed limit of 45 mph or greater, perform smoothness acceptance testing of the longitudinal profile of the finished pavement surface using an Inertial Profiler in accordance with Sections 610 and 710 of the 2018 *Standard Specifications for Roads and Structures*. The North Carolina Hearne Straightedge will not be permitted.

REINFORCED CONCRETE PIPE DESIGN

(9-1-11) (Rev. 9-8-17)

DB3 R006

Description

This work consists of the design and manufacture of reinforced concrete pipes which require fills greater than 40 feet and less than or equal to 80 feet.

Materials

(A) Design

When the design of a reinforced concrete pipe is required on the plans developed by the Design-Build Team, design the reinforced concrete pipe in accordance with the current edition of the AASHTO LRFD Bridge Design Specifications. Provide the diameter of pipe as indicated on the plans developed by the Design-Build Team and manufacture the pipe in accordance with ASTM C 1417. Provide a reinforced concrete pipe that meets the requirements of Section 1032-6, Section 1077 and any other applicable parts of the 2018 *Standard Specifications for Roads and Structures*.

The design of the reinforced concrete pipe shall be the Design-Build Team's responsibility and shall be subject to review, comments and approval. Submit two sets of detailed plans for review and acceptance. Include all details in the plans, including the size and spacing of the required reinforcement necessary to fabricate the reinforced concrete pipe. Include

checked design calculations for the reinforced concrete pipe. Have a North Carolina Registered Professional Engineer seal the plans and design calculations. After the plans are reviewed and, if necessary, all corrections made, submit one set of reproducible tracings on 22" x 34" sheets to become part of the plans developed by the Design-Build Team.

(B) Reinforced Concrete Pipe Sections

(1) Class

Reinforced concrete pipe sections manufactured in accordance with this Project Special Provision shall be designated by inside pipe diameter and design earth cover.

(2) Design Criteria

The design of the reinforced concrete pipe shall be in accordance with Article 12.10.4.2 "Direct Design Method" of the current edition of the AASHTO LRFD Bridge Design Specifications. The following assumptions shall be used in the design calculations:

NCDOT Criteria for Direct Design Method
Process and Material Factors Radial Tension, $F_{rp}=1.0$ Shear Strength, $F_{vp}=1.0$
Design Concrete Strength - f'_c 5,000 psi < f'_c < 7,000 psi
Heger Pressure Distribution - Type 2 Installation Vertical Arching Factor = 1.40 Horizontal Arching Factor = 0.40
Soil Unit Weight = 120 lb / ft ³
Depth of Fluid = Inside Pipe Diameter
Minimum Concrete Cover = 1.00"
Crack Control = 0.90 (maximum)

(C) Joints

Produce the reinforced concrete pipe sections with spigot and bell ends. Design and form the ends of the pipe section so, when the sections are laid together, they make a continuous line of pipe with a smooth interior free of appreciable irregularities in the flow line, and compatible with the permissible variations given in the 2018 *Standard Specifications for Roads and Structures* and ASTM C 1417.

(D) Manufacture

In addition to the requirements of the 2018 *Standard Specifications for Roads and Structures* and ASTM C 1417, devices or holes are permitted in each pipe section for the purpose of handling and placement. Submit details of handling devices or holes for

approval and do not cast any concrete until approval is granted. Remove all handling devices flush with concrete surfaces as directed. Fill holes in a neat and workmanlike manner with an approved non-metallic non-shrink grout, concrete or plug.

DRAINAGE PIPE

(9-1-11)

DB3 R36

Description

Where shown in the plans developed by the Design-Build Team, the Design-Build Team shall use Reinforced Concrete Pipe, Corrugated Aluminum Alloy Pipe, Aluminized Corrugated Steel Pipe, Corrugated Polyethylene Pipe (HDPE Pipe) or Polyvinyl-Chloride Pipe (PVC Pipe) in accordance with the following requirements:

- All pipe types shall be subject to the maximum and minimum fill height requirements as found on Roadway Standard Drawing No. 300.01 - Sheet 3 of 3. The appropriate Reinforced Concrete Pipe class and the appropriate gage thickness for Corrugated Aluminum Alloy Pipe and Aluminized Corrugated Steel Pipe shall be selected based on fill height.
- Site specific conditions may limit a particular material beyond what is identified in this Project Special Provision. These conditions include, but are not limited to, abrasion, environmental, soil resistivity and pH, high ground water and special loading conditions. The Design-Build Team shall determine if additional restrictions are necessary.
- Slope drains shall be Corrugated Aluminum Alloy Pipe, Aluminized Corrugated Steel Pipe, Corrugated Polyethylene Pipe (HDPE Pipe) or Polyvinyl-Chloride Pipe (PVC Pipe).
- Transverse median drains, storm drainage system pipes, and open-ended cross drains shall be Reinforced Concrete Pipe unless the pipe slope is greater than 10%, in which case the pipe shall be either Corrugated Aluminum Alloy Pipe or Aluminized Corrugated Steel Pipe.

CEMENT AND LIME STABILIZATION OF SUB-GRADE SOILS

(5-20-13) (Rev. 9-8-17)

DB5 R21

General

The Design-Build Team shall be responsible for the following:

1. Performing all laboratory tests in a laboratory certified by the AMRL / NCDOT Laboratory Proficiency Program
2. Sampling Sub-grade soils
3. Conducting Laboratory tests to determine:
 - a. Soil classifications
 - b. Moisture-density relationships
 - c. Quantity of lime or cement required to achieve specified strengths

4. Designating areas to be stabilized by either lime or cement and the required rates of application
5. Conducting field tests to determine unconfined compressive strength

Sampling

The Design-Build Team shall take soil samples, after the project has been graded to within two inches of final sub-grade elevation. The Design-Build Team shall sample the top eight inches at a minimum frequency of one sample per 1,000 feet, per each lane, for classification tests; and one sample per 3,000 feet, per each lane, for moisture density tests and lime or cement mix design tests. For the aforementioned tests, a lane shall be considered 28 feet wide in one direction for sampling purposes. Additional samples shall be taken to ensure that all the predominant soil types, limits of distribution of these soils and different site conditions have been represented.

Classification Tests

The Design-Build Team shall perform the following tests to determine AASHTO classifications of different soils in accordance with AASHTO specifications as modified by NCDOT. Copies of these modified procedures can be obtained from Materials and Test Unit's Soils Laboratory.

TABLE 1

<u>TEST</u>	<u>AASHTO DESIGNATION</u>
Dry Preparation of Disturbed Soils	T-87
Particle Size Analysis of Soils	T-88
Determining the Liquid Limit of Soils	T-89
Determining the Plastic Limit and Plasticity Index of Soils	T-90

Moisture Density Test

Based on the criteria set in Table 2, below, the Design-Build Team shall perform the Moisture Density Tests, using either lime or cement. The Design-Build Team shall use 10% cement by weight in soil cement and 4% lime by weight, in soil-lime mixtures. The Design-Build Team shall conduct the tests in accordance with AASHTO T-99, and T-134 for soil-lime and soil-cement mixtures, respectively. In each case, The Design-Build Team shall determine the maximum dry density and optimum moisture content.

TABLE 2

<u>CRITERIA FOR SELECTING LIME OR CEMENT</u>		
PROPERTY	A	B
Percent passing #200 Sieve	35 Max	36 Min
Liquid Limit	40 Max	41 Min
Plasticity Index	10 Max	25 Min

The Design-Build Team shall use cement for all soils meeting criteria in Column A and lime for all soils meeting criteria in Column B. The Design-Build Team may choose either lime or cement for all soils not meeting all criteria in either Column A or B.

DETERMINING THE APPLICATION RATES FOR SOIL-CEMENT AND SOIL-LIME MIXTURES

Soil-Cement Mixtures

For soil-cement mixtures, the Design-Build Team shall be required to do the following:

- Make specimens at optimum moisture content using a quantity of cement in the range of 5 to 12 percent by weight.
- Compact the specimens to a minimum density of 95% of maximum dry density obtained using AASHTO T 134.
- Make a minimum of two specimens for each selected cement rate.
- Cure the specimens for seven days in a moist room maintained at a temperature of 73° F \pm 2.7° and a humidity of 100%. At the end of the curing period, immerse the specimens in water for four hours.
- After immersion, test the specimens in unconfined compression in accordance with ASTM D 1633.
- Report the maximum strength obtained and the corresponding percent strain.
- Select the rate of cement that provides a minimum unconfined compressive strength of 200 psi and a maximum of 400 psi.

Soil-Lime Mixtures

For soil-lime mixtures, the Design-Build Team shall be required to do the following:

- Make specimens at optimum moisture content using a quantity of lime in the range of 3.5 to 6.5 percent by weight.
- Compact specimens to a minimum density of 95% of maximum dry density obtained by AASHTO T99.
- Make a minimum of two specimens for each selected lime rate.
- Cure the specimens in sealed plastic bags for 48 hours in an oven at a temperature of 118° F. Do not immerse the specimens in water at the end of the curing period.
- Test the specimens in unconfined compression in accordance with AASHTO T 208. Report the maximum strength obtained and the corresponding percent strain.
- Select the rate of lime that provides a minimum unconfined compressive strength of 60 psi.

Submittals for Review and Approval Prior to Construction

The Design-Build Team shall adhere to the following submittal guidelines:

- Submit all laboratory test results for review.
- Submit a sketch in plan view showing areas of the project to be stabilized by either lime or cement and application rates for each stabilizer.
- Submit any other documentation that supports the Design-Build Team's recommendations.

Construction of Lime Treated Subgrade

The Design-Build Team shall construct the lime treated sub-grade as specified in Section 501 of the North Carolina Department of Transportation 2018 *Standard Specifications for Roads and Structures* with the following exceptions:

Subsection 501-4 Equipment

Contractor's equipment will not require engineer's approval.

Subsection 501-8 (A) General

Paragraph #1 is not applicable to this project.

Subsection 501-9 (B) Preliminary Curing

Amend as follows: Allow a minimum of two days and a maximum of four days for preliminary curing.

Subsection 501-10 Compacting, Shaping, and Finishing

Last paragraph is not applicable.

Subsection 501-11 Thickness

Last two paragraphs are not applicable.

Construction of Cement Treated Subgrade

The Design-Build Team shall construct the soil cement sub-grade as specified in Section 542 of the 2018 *Standard Specifications for Roads and Structures*, with the following exceptions:

Subsection 542-4 Equipment

Contractor's equipment will not require Engineer's approval.

Subsection 542-7 Application of Cement

First paragraph is not applicable.

Subsection 542-11 Thickness

Paragraphs 2 and 3 are not applicable.

Unconfined Compressive Strength

In addition to the field tests conducted by the Design-Build Team, the lime-stabilized subgrades will be tested by the Department or their agent using Dynamic Cone Penetrometer (DCP) and / or by making field specimens. DCP testing will be in accordance with *Quality Assurance Testing of Lime-Treated Soils Utilizing the Dynamic Cone Penetrometer*, Test Method #1-2005. The required unconfined compressive strength for lime shall be 60 psi, which corresponds to a penetration per blow of approximately 0.5 inches of the Dynamic Cone Penetrometer. The minimum and maximum required unconfined compressive strength for soil cement shall be 200 psi and 400 psi, respectively.

PRICE ADJUSTMENTS FOR ASPHALT BINDER

(9-1-11) (Rev. 9-8-17)

DB6 R25

Price adjustments for asphalt binder for plant mix will be made in accordance with Section 620 of the 2018 *Standard Specifications for Roads and Structures*.

The base price index for asphalt binder for plant mix is \$ 495.56 per ton.

This base price index represents an average of F.O.B. selling prices of asphalt binder at supplier's terminals on January 1, 2019.

PRICE ADJUSTMENTS - ASPHALT CONCRETE PLANT MIX

(9-1-11) (Rev. 9-8-17)

DB6 R26

Revise the 2018 *Standard Specifications for Roads and Structures* as follows:

Page 6-15, Article 609-11 and Page 6-31, Article 610-14

Add the following paragraph before the first paragraph:

The “Asphalt Price” used to calculate any price adjustments set forth in this section shall be \$40.00 per theoretical ton. This price shall apply for all mix types.

BLACK EPOXY PAVEMENT MARKING MATERIAL

(1-26-17)

Description

This work shall consist of applying black epoxy pavement marking material on concrete.

Epoxy Pavement Marking Material

(A) Formulation

Use epoxy pavement marking material consisting of 100% solid two-part system formulated and designed to provide a simple volumetric mixing ratio of the two components.

(B) Epoxide Value: ASTM D1652

WPE of the epoxy resin shall be 250 ± 50 for both white and yellow component A on a pigment free basis.

(C) Amine Value ASTM D2074

The total amine value of the curing agent (component B) shall be 450 ± 50

(D) Requirements

(1) Color

Black: Shall meet ASTM standard

(2) Hardness:

ASTM D2240

Minimum Shore D hardness:

80

(3) Abrasion Resistance:

ASTM C-501

Minimum wear index of catalyzed sample:

80

(4) Adhesion to Concrete:

ASTM D4541

At 100% concrete failure:

greater than 325 psi

(5) Tensile Strength:

ASTM D638

Minimum average tensile strength:

6000 psi

(6) Compressive Strength:

ASTM D695

Minimum compressive strength:	12000 psi
(7) Drying Time:	ASTM D711
Maximum drying time at 75±2°F:	10 minutes
(8) Gel Time:	ASTM D2471
Maximum gel time:	3 minutes

(E) Material Certification: Type 3 Material Certification and Type 4 Material Certification

Construction Methods

Epoxy Pavement Marking Material shall conform to the requirements of Section 1205 of the *Standard Specifications for Roads and Structures*.

(A) Application Equipment

Use epoxy application equipment, which is equipped with or capable of the following:

- Precisely metering the two components in the ratio of proportion recommended by the manufacturer.
- Producing the required amount of heat at the mixing head and gun tip.
- Maintaining temperatures within the tolerances recommended.
- Gauges for each proportioning pump so that any pressure difference can be easily monitored.
- A minimum 24" long static mixer unit for proper mixing of the two components of the epoxy marking material.
- Each component of the epoxy pavement marking shall be in a homogeneous state prior to mixing,
- Have the capability to totally mix component A with component B immediately prior to the marking application.
- Have the capability to spray pavement marking material and have the equipment mounted on a truck of sufficient size and stability with an adequate power source to produce uniform lines of the specified dimension.
- A metering device to register the accumulated installed footage for each gun

(B) Weather Limitations

Apply epoxy pavement marking only when the ambient air temperature and the pavement surface temperature is a minimum of 35° F and rising.

(C) Application

Produce epoxy pavement marking lines that have a minimum dry thickness of 15 mils when placed on concrete pavements and 20 mils when placed on asphalt pavements.

Use **Type I** epoxy material (fast dry) for epoxy pavement markings except when otherwise specified in the contract documents.

Type II epoxy material may be used with lane closures as approved by the Engineer to allow for curing time.

Do not place epoxy markings on fresh asphalt pavements until 15 days have elapsed after the last asphalt layer is placed.

Using the epoxy application equipment, apply the pavement marking materials simultaneously. Hot-spray the epoxy resin, mixed in accordance with the manufacturer's recommendations, onto the pavement surface within an application temperature range recommended by the manufacturer. Inject retroreflective glass beads into the molten (liquid) Epoxy Marking.

Individual Components: Before mixing, heat the individual components to within the temperature range of 100° F to 170° F. Do not exceed the upper limit of the manufacturer's recommended heating temperature at any time under any circumstances.

Mixed Material: After mixing, ensure that the application temperatures for the combined materials at the gun tip are within the temperature range recommended by the manufacturer for the particular product used.

Produce marking, which upon cooling, has the ability to resist deformation caused by traffic throughout its entire length.

(D) Observation Period

Epoxy pavement markings shall be subject to a 30-day observation period.

Maintain responsibility for the pavement markings for a 30-day observation period beginning upon the satisfactory completion of all work required in the plans developed by the Design-Build Team. Guarantee the markings under the payment and performance bond in accordance with Article 105-17 of the *Standard Specifications for Roads and Structures*.

Have traffic operating on the facility during the entire 30-day observation period unless otherwise directed.

Provide pavement marking material, which during the 30-day observation period, shows no signs of failure due to blistering, excessive cracking, chipping, bleeding, staining, discoloration, oil content of the pavement materials, smearing or spreading under heat, deterioration due to contact with grease deposits, oil, diesel fuel, or gasoline drippings,

spilling, poor adhesion to the pavement materials, vehicular damage, debonding and normal wear.

Replace, at no additional expense to the Department, any pavement markings that do not perform satisfactorily under traffic during the 30-day observation period.

FIELD OFFICE

(6-1-07) (Rev. 6-22-15)

DB 08-01

Description

This work consists of furnishing, erecting, equipping, and maintaining a field office for the exclusive use of Department Engineers and Inspectors at a location on the project approved by the Engineer. Provide a field office that complies with the current A.D.A. Design and Accessibility Standards, the National Electric Code, local, state, and federal regulations, and the following:

Procedures

The field office and equipment shall remain the property of the Design-Build Team upon completion of the contract. The field office must be separated from buildings and trailers used by the Design-Build Team and shall be erected and functional as an initial operation. Failure to have the field office functional when work first begins on the project will result in withholding payment of the Design-Build Team's monthly progress estimate. The field office must be operational throughout the duration of the project and be removed upon completion and final acceptance of the project.

Provide a field office that is weatherproof, tightly floored and roofed, constructed with an air space above the ceiling for ventilation, supported above the ground, has a width of at least ten feet, and the floor-to-ceiling height that is at least 7 feet 6 inches. Provide inside walls and a ceiling that are constructed of plywood, fiber board, gypsum board, or other suitable materials. Have the exterior walls, ceiling, and floor insulated.

Provide a field office with a minimum floor space of 500 square feet and that is equipped with the following:

<u>Number</u>	<u>Item</u>
1	Double-pedestal desk (approximately 60 by 34 inches, at least 2,000 square inches)
1	Plan and drafting table (approximately 30 by 96 inches) with adjustable stool
1	Computer table having a minimum size of 48 by 30 by 29 inches
1	Plan rack for 24 by 36 inch drawings with 6 plan clamps
1	Printing calculator
2	2-drawer fire protection file, 15 inch drawer width, minimum UL rating of Class 350
6	Office chairs with a minimum of two having casters
2	Wastebaskets
1	Pencil sharpener
1	Copy machine (8 inch x 11 inch copies)
1	Telephone

- 1 Fax Machine
- 1 Answering machine
- 1 Internet Connection Service (modem for Wi-Fi)

Windows and Doors

Provide a field office with at least three windows, with blinds, each having an area of at least 540 square inches, capable of being easily opened and secured from the inside and having at least two exterior passage doors. Provide doors at least 30 inches in width and 78 inches in height. Provide screens for windows and doors. Equip exterior passage door(s) with lock(s), and furnish at least two keys to the Engineer or inspector.

Steps

Provide accessibility in compliance with the current A. D. A. Design and Accessibility Standards, and the State Building Code and maintain them free from obstructions.

Storage Facility For Nuclear Gage

Furnish the field office with an outside storage facility for the Department's nuclear gage. The storage facility shall not be located within ten feet of any other structure including the field office.

Lighting, Heating, and Air Conditioning

The field office must have satisfactory lighting, electrical outlets, heating equipment, an exhaust fan, and an air conditioner connected to an operational power source. Provide at least one of the light fixtures that shall be a fluorescent light situated over the plan and drafting table. Furnish electrical current and fuel for heating equipment.

Fire Extinguishers

Furnish and maintain one fire extinguisher for each required exterior passage door. Fire extinguisher(s) may be chemical or dry powder. UL Classification 10-B:C (minimum), suitable for Type A:B:C: fires. Mount and maintain fire extinguisher(s) in accordance with OSHA Safety and Health Standards.

Toilets

Provide a toilet conforming to the requirements of the state and local boards of health or other bodies or courts having jurisdiction in the area. When separate facilities for men and women are not available, place a sign with the words "Rest Room" (with letters at least 1 inch in height) over the doorway, and provide an adequate positive locking system on the inside of the doorway. Maintain responsibility for the water and sewer connections or the installation and connection of a water well and septic tank and drain field. These facilities must conform to all local and state permits.

Utilities

Except for telephone service, make arrangement for necessary internet and utility connections, maintain internet and utilities, pay internet and utility service fees and bills, and make arrangements for final disconnection of internet and utilities. Furnish a telephone in each field office and permit the work necessary to install it. Installation and service fees for the telephone will be paid for by the Department.

Storage Facility for Test Equipment

Provide the field office with a storage facility, separate from the office for storage of test equipment, other than the nuclear gage. Provide a facility that has a minimum floor space of 64 square feet, is weatherproof, tightly floored and roofed, and has a tamper resistant key operated lock.

Miscellaneous Items

The field office must also include the following:

1. A certification that the office is free of asbestos and other hazardous materials.
2. A broom, dust pan, mop and bucket, and general cleaning supplies.
3. Provide and maintain an all-weather parking area for six vehicles, including graveled access to the paved surface.

GEOTEXTILE FOR PAVEMENT STABILIZATION

(5-7-14) (Rev. 5-24-18)

DB 08-05

Description

Supply and install geotextile for pavement stabilization in accordance with the Geotechnical Engineering Scope of Work found elsewhere in this RFP.

Materials

Refer to Division 10 of the 2018 *Standard Specifications for Roads and Structures*.

Item	Section
Geotextiles	1056

Provide Type 5 geotextile for pavement stabilization that meets the following tensile strength requirements in the machine direction (MD) and cross-machine direction (CD):

GEOTEXTILE FOR PAVEMENT STABILIZATION REQUIREMENTS		
Tensile Strength	Requirement (MARV ^A)	Test Method
Tensile Strength @ 5% Strain (MD & CD ^A)	1,900 lb/ft	ASTM D4595
Ultimate Tensile Strength (MD & CD ^A)	4,800 lb/ft	ASTM D4595

- A. MD, CD and MARV per Article 1056-3 of the 2018 *Standard Specifications for Roads and Structures*.

Construction Methods

For all locations, follow the criteria above and as provided in the Geotechnical Engineering Scope of Work found elsewhere in this RFP.

Place geotextile for pavement stabilization above chemically stabilized subgrades or below aggregate as shown in the plans developed by the Design-Build Team. Pull geotextiles taut so they are in tension and free of kinks, folds, wrinkles or creases. Install geotextile for pavement stabilization parallel to the survey or lane line in the MD and adjacent to each other in the CD as shown in the plans developed by the Design-Build Team. Geotextiles shall be overlapped 18" in the MD and CD. Completely cover stabilized subgrades with geotextile for pavement stabilization. Hold geotextiles in place with wire staples or anchor pins as needed.

Do not damage geotextile for pavement stabilization when placing aggregate. Place and compact aggregate in accordance with this scope of work and the 2018 *Standard Specifications for Roads and Structures*. Do not operate heavy equipment on geotextiles any more than necessary to construct base courses or subgrades. Replace any damaged geotextiles to the satisfaction of the Engineer.

NONWOVEN GEOTEXTILE INTERLAYER

(1-13-14)

DBI 10-07

Description

Furnish and install a nonwoven geotextile interlayer at locations shown in the plans prepared by the Design-Build Team.

General

The Design-Build Team shall schedule a Pre-Pave Meeting at least three weeks prior to paving to discuss installation and construction procedures for the nonwoven geotextile interlayer with representatives from the Design-Build Team including Paving Superintendent, Subcontractor, Geotextile Manufacturer, Engineer, Roadway Inspector, Area Roadway Construction Engineer, Division Construction Engineer, and the State Pavement Construction Engineer.

Materials

The geotextile interlayer shall be constructed of a non-woven needle-punched geotextile, with no thermal treatment (calendaring or IR). The material shall be resistant to chemicals, mildew, and rot and shall not have any tears or holes that will adversely affect the in-situ performance and physical properties of the installed material.

Furnish with each shipment a Type 3 Certification in accordance with Article 106-3 of the 2018 NCDOT *Standard Specifications for Roads and Structures* certifying that the paving mat is a non-

woven needle-punched geotextile with no thermal treatment (calendaring or IR) meeting the requirements shown:

Physical Properties of Non-Woven Geotextile Interlayer			
Property	Test Method	Units	Value
Minimum Mass per unit area	ASTM D 5261	oz/yd ²	15.0
Minimum thickness under load (a) at 2 kPa (0.29 psi) (b) at 20 kPa (2.9 psi) (c) at 200 kPa (29 psi)	ASTM D 5199	in	(a) 0.12 (b) 0.10 (c) 0.04
Minimum wide-width tensile strength	ASTM D 4595	lb/ft	685
Maximum wide-width elongation	ASTM D 4595	%	130
Minimum water permeability in normal direction under load (pressure) at 20 kPa (2.9 psi)	Mod. ASTM D 5493 or ASTM D 4491	ft/s	3.3x10 ⁻⁴
Minimum in-plane water permeability (transmissivity) under load (pressure) (a) at 20kPa (2.9 psi) (b) at 200kPa (29 psi)	Mod. ASTM D 6574 or ASTM D 4716	ft/s	(a) 1.6x10 ⁻³ (b) 6.6x10 ⁻⁴
Minimum weather resistance retained strength	ASTM D 4355 at 500 hrs. exposure	%	60
Alkali resistance, minimum polypropylene / polyethylene	Manufacturer certification of polymer	%	96

Note: Requirements must be met for 95 percent of samples.

General Requirements

A trained and experienced installer, certified by the Geotextile Manufacturer, shall be present on-site during the installation of the geotextile and until the crew has a comfort level working with this material.

Ensure that any potential for keying of the two cementitious layers is minimized through proper repair techniques. Clean the underlying surface to remove loose debris before applying the interlayer. Roll the geotextile out on the underlying layer. The geotextile shall be tight and without excess wrinkles and folds. No more than 650 feet of geotextile shall be installed in advance of the paving operation at a given time. The interlayer shall be placed no more than 3 days before concrete placement.

Keep driving on the interlayer to a minimum. Tight radius turns and excessive acceleration and braking shall be avoided.

The geotextile shall be secured to the underlying layer with pins or nails punched through 2 to 2.75 inch galvanized washers or disks every 6 feet or less. Additional fasteners shall be used as needed to ensure that the geotextile does not shift or fold before or during concrete placement.

Edges of the geotextile shall overlap by 8 +/- 2 inches. No more than three layers of geotextile shall overlap at any location. Transverse seams of adjacent rolls shall be staggered to prevent four layers from coinciding at any location. The free edge of the geotextile shall extend beyond the edge of the new concrete into a location that facilitates drainage.

INTERNATIONAL ROUGHNESS INDEX

The following amendments to the 2018 *NCDOT Standard Specifications for Roads and Structures* apply to this project:

Page 6-26, replace Table 610-8 with the following:

Table 610-8	
MRI Price Adjustment Per 0.10-Mile Section	
MRI After Completion (Inches Per Mile)	Price Adjustment Per Lane (0.10-Mile Section)
45.0 and Under	\$200.00
45.1-55.0	PA = 600 – (10 * MRI)
55.1-70.0	Acceptable (No Pay Adjustment)
Over 70.0	Corrective Action Required

Page 7-15, replace Table 710-1 with the following:

Table 710-1	
MRI Price Adjustment Per 0.10-Mile Section	
MRI After Completion (Inches Per Mile)	Price Adjustment Per Lane (0.10-Mile Section)
45.0 and Under	\$200.00
45.1-55.0	PA = 600 – (10 * MRI)
55.1-70.0	Acceptable (No Pay Adjustment)
Over 70.0	Corrective Action Required

ROLLER COMPACTED CONCRETE

(05-17-16)

1000

SPI 7-18

Description

Construct Roller Compacted Concrete (RCC) pavement on a prepared base, in accordance with these provisions and with lines, grades, thicknesses, and typical sections as shown on the plans. This work includes, but is not limited to, the designing of the mix; producing, furnishing and placing of the concrete; compaction; finishing; constructing joints; curing the pavement; coring for test specimens and associated patching of the pavement; and quality control testing.

Submit the following for approval a minimum of 30 days prior to the start of any production of RCC:

- (A) Submit RCC mix design in accordance with Section 1000-3(A) of the *2018 Standard Specifications for Roads and Structures* except as noted herein. The submitted design shall minimally include aggregate gradation, cementitious materials, admixtures (if used), compressive strength (minimum 4,500 psi at 28 days), required moisture and density to be achieved and quantities of individual materials per cubic yard for the mix design. Minimum cement content per cubic yard is 450 pounds. Measurement and reporting of flexural strength is not required.
- (B) Submit a Process Control Plan detailing the personnel, equipment, production, placement, compaction, sampling, testing and repair operations.

Schedule a pre-pave meeting prior to installing the RCC including representatives from the Contractor, Subcontractor, Project Engineer, Area Roadway Construction Engineer, the State Pavement Construction Engineer, NCTA, and a representative from the Materials and Tests Unit.

Materials

- (A) General

All materials shall meet the requirements of the *2018 Standard Specifications*.

Item	Section
Portland Cement Concrete	1000
Curing Agents	1026
Joint Filler	1028-1
Low Modulus Silicone Sealant	1028-3
Water	1024-4

- (B) Aggregates

Furnish aggregates conforming to Section 1014 of the *2018 Standard Specifications*. The plasticity index of the aggregate shall not exceed five. Provide a well-graded aggregate blend conforming to the following gradation:

GRADATION FOR ROLLER COMPACTED CONCRETE AGGREGATE	
Sieve Size	% Passing by Weight
1"	100
3/4"	95 - 100
1/2"	70 - 90
3/8"	60 - 85
No. 4	40 - 60
No. 8	30 - 50
No. 16	20 - 40
No. 100	0 - 18
No. 200	0 - 8

Other aggregate blends may be considered provided demonstration of past performance and mix approval prior to production.

Equipment

(A) General

Provide maintained equipment and tools that will produce a completed RCC pavement meeting the requirements of this provision. All equipment shall be on site, inspected and in good operating condition before work may proceed.

(B) Concrete Mixing Plant

A pugmill plant shall be a central plant with a twin shaft pugmill mixer, capable of batch and continuous mixing, equipped with synchronized metering devices and feeders to maintain the correct proportions of aggregate, cement, mineral admixtures, and water. Other pugmill plant requirements are as follows:

Ensure that all aggregate stockpiles have adequate separation to prevent cross contamination and are handled in a manner that prevents segregation.

Control feed rate by a variable speed belt or an operable gate calibrated to accurately deliver any specified quantity of material. If two or more aggregate stockpiles are used, the feed rate from each bin shall be readily adjustable to change aggregate proportions, when required. Feed rate controls must maintain the established proportions of aggregate from each stockpile bin when the combined aggregate delivery is increased or decreased.

Operate plant scales in accordance with Sub-article 1000-9(C) of the *2018 Standard Specifications*.

Minimize segregation during loading of delivery trucks. Loading directly from a belt or auger will not be permitted.

(C) Paver

Utilize a high density paver, which provides a minimum of 90% of the maximum wet density in accordance with ASTM D1557 or equivalent test method at placement.

Provide a paver of suitable weight and stability to spread and finish the RCC material, without segregation, to the required thickness, smoothness, surface texture, cross-section and grade.

(D) Compactors

Provide self-propelled steel drum vibratory rollers having a minimum static weight of 10 tons for primary compaction. Provide rollers equipped with controls that automatically disengage the vibration mechanism before the roller stops. For final compaction, use a

combination of self-propelled steel drum roller, in static mode, and a rubber tire roller weighing between 4 and 10 tons as necessary to achieve an acceptable surface.

Use walk-behind vibratory rollers or plate tampers for compacting areas inaccessible to the large rollers. Ensure that areas compacted with walk-behind equipment meet all requirements for compaction and surface quality. If sufficient compaction and texture cannot be achieved with walk-behind equipment, use conventional concrete in the inaccessible areas.

(E) Water Trucks

Provide at least one water truck or other similar equipment on-site capable of evenly applying a fine spray of water to dampen the base or subgrade surface ahead of RCC placement and to keep the surface of the RCC moist without damaging the final surface.

(F) Hauling Equipment

Use non-agitating hauling equipment having bodies which are smooth, watertight, metal containers equipped with vibrators and gates to discharge the concrete without segregation or damage. Provide fitted covers to protect the material from rain and excessive evaporation.

Prevent the accumulation of hardened concrete in the delivery vehicles, providing a washout station, if necessary, to prevent the accumulation of material. Discharge all flushing water before charging with the next RCC load.

(G) Concrete Saws

Use early-entry concrete saws that are capable of sawing the concrete the same day as placement and as soon as the concrete can be cut for crack control without raveling and to the depth required. Once hardened, use standard wet saw-cutting equipment if additional saw cuts are necessary. Equip all saws with blade guards and guides or devices to control alignment and depth.

Preparation of Subgrade and Base

Prior to the placement of RCC pavement, verify the subgrade and base has proper density and grade tolerances in accordance with Section 500-3 of the *Standard Specifications for Roads and Structures* and repair any soft or yielding areas. Correct all damaged areas in the subgrade or base prior to placing concrete. Keep the base clean and free of foreign material.

Dampen the surface of the base uniformly at the time the RCC pavement mixture is placed. Ensure that no free water or ponding is present at the time of concrete placement.

Weather Limitations**(A) Cold Weather**

Do not place RCC when any of the following conditions exist:

- (1) When base contains frost or frozen material.
- (2) When the air temperature is 35°F and descending.

Maintain a sufficient supply of insulating blankets, plastic sheeting or other suitable material. Apply insulating materials to maintain a minimum temperature of 40°F at the pavement surface for a minimum of five days.

(B) Hot Weather Precautions

Do not place RCC when the air temperature is 90°F and rising and RCC temperature is greater than 95°F.

(C) Rain

Do not place RCC pavement during rain conditions sufficient to be detrimental to the finished product. Placement may continue during drizzle or mist conditions provided the surface of the RCC pavement is not eroded or damaged in any way. The Engineer will be the sole judge as to when placement must be stopped due to rain.

Construction Methods**(A) Delivery**

Provide a sufficient number of trucks to ensure an adequate and continuous supply of RCC material to the paver. Deliver the concrete to the work site in a thoroughly mixed and uniform mass. Minimize the elapsed time to be 45 minutes or less, unless longer times can be demonstrated to provide acceptable performance to the satisfaction of the Engineer. The Engineer may rescind approval for longer elapsed times if the performance becomes unsatisfactory due to changes in weather, materials, or any other pertinent reason. The elapsed time is defined as the period from first contact between mixing water and cement until the entire operation of placing and compacting, including corrective measures if necessary, has been completed.

(B) Placement

Deposit the RCC material into a material transfer vehicle prior to placing into the hopper of the paver.

If at discharge, the concrete is not thoroughly mixed and homogeneous, the charging sequence, size of load, mixing time or any combination thereof should be altered to meet these requirements; otherwise, utilize other equipment capable of delivering a thoroughly mixed and uniform concrete mass.

Maintain an adequate quantity of RCC in the paver and do not allow the paver to become empty between loads. Maintain the material above the auger shaft at all times during paving.

Operate the paver in a manner that will prevent segregation and produce a smooth continuous surface without excessive tearing, pulling or shoving. Limit the placement of RCC to a length that can be compacted and finished within the appropriate time limit under the prevailing air temperature and wind conditions.

Advance the paver in a steady, continuous operation with minimal starts and stops. Limit the paver speed during placement operations to ensure that density requirements are met and surface distress is minimized.

Broadcasting or fanning the RCC material across areas being compacted will not be permitted. Such additions of material shall only be done immediately behind the paver and before any compaction has taken place. Any segregated coarse aggregate shall be removed from the surface before rolling.

If segregation occurs in the RCC during paving operations, the placement shall cease and the segregated materials shall be removed and replaced with fresh RCC before rolling.

(C) Compaction

Immediately after the concrete has been placed, thoroughly and uniformly compact the pavement.

Determine the sequence and number of roller passes by vibratory and non-vibratory rolling to obtain the specified density and surface finish. Avoid displacement of the RCC pavement. Immediately correct any displacement of the surface resulting from reversing or turning action of the roller. Smooth any uneven marks left during the vibrating rolling with a steel drum or rubber tire roller(s) operated in static mode. Provide a final surface meeting the smoothness and finish grade requirements of this section, and free of excessive surface tears and cracks.

Areas inaccessible to either the paver or rollers may be placed by hand and compacted with equipment specified within this provision. Compaction of these areas must satisfy the same minimum density requirements as specified below. An alternate and preferred method for paving inaccessible areas is to use cast-in-place, air-entrained concrete with a minimum compressive strength of 4,000 psi.

Provide additional rolling to longitudinal joints as necessary to produce the specified density for the full depth of the lift and produce a tight smooth joint.

(D) Density Testing

The RCC pavement will be evaluated for density on a lot by lot basis. A lot will consist of 2,000 SY of newly placed RCC. In-place field density tests shall be performed in accordance with ASTM C 1040, direct transmission, as soon as possible, but no later than 30 minutes after completion of rolling at three randomly selected locations within the lot that are no closer than 12 inches from a free edge or 6 inches from a confined edge. Only wet density shall be used for evaluation. Based on these three tests, an average density not less than 98% of the maximum wet density obtained by ASTM D 1557 or equivalent test method is required, with no individual test less than 96%.

In addition to determining the density within the mat, determine the in-place wet joint density on joints at three random locations at a of distance 12 inches from a free edge or 6 inches from a confined edge, as appropriate. The average of three wet joint density tests shall be not less than 96% and none of the density tests shall be less than 94% of the maximum wet density obtained by ASTM D 1557 or equivalent test method.

If the Engineer determines that a given lot does not meet the minimum specification density requirements but the work is reasonably acceptable, the lot will be accepted at a reduced pay factor in accordance with the following formula. The reduced pay factor will apply only to the RCC unit price.

$$\text{Reduced Pay Factor} = 100 + \left[\frac{\text{Actual Density} - \text{Specified Density}}{2} \right] * 25$$

Where:

Actual Density = the lot average density, not to exceed 4.0% of the specified density

Specified Density = the wet density or joint density specified in the contract

Any density lot not meeting minimum density requirements will be evaluated for acceptance in accordance with Article 105-3.

(E) Strength Testing

(1) Mix Design

The proposed RCC mix design shall have a minimum compressive strength of at least 4,500 psi in accordance with ASTM C39 based on test results of 6"x12" cylinders prepared in accordance with ASTM C1435. Cure and transport specimens to the laboratory in accordance with ASTM C 31.

(2) Production Quality Control Strength Testing

The RCC pavement will be evaluated for compressive strength on a lot by lot basis. A lot will consist of 2,000 SY of newly placed RCC or a fraction thereof. Obtain one sample of fresh RCC during the placement of each lot and make at least three

6" X 12" cylinders in accordance with ASTM C1435. The average of two cylinders tested at 28 days shall be the compressive strength for that lot.

(F) Curing

After final finish and immediately after the free surface moisture has disappeared, apply curing compound at a rate of 0.0067 gallons per square foot. Provide an inline flow metering device to ensure the proper application rate is provided. Apply the curing compound such that puddling or ponding does not occur on the fresh concrete surface.

(G) Finishing

The finished surface of the RCC pavement, when tested with a 10 foot straight edge or crown surface template, shall not vary from the straight edge or template by more than 3/8 inch at any one point. When the surface smoothness is outside the specified surface tolerance, the surface shall be grinded to within the tolerance by use of a self-propelled diamond grinder. Milling of the final surface is not acceptable.

(H) *Joint Construction*

Construct joints to assure continuous bond between new and previously placed lanes. A vertical joint is considered a fresh joint when an adjacent RCC lane is placed no later than 60 minutes of placing the previous lane. This time may be reduced by the Engineer when conditions such as hot, dry, and/or windy weather are encountered. The Engineer may further require measures to keep the fresh joint moist, including but not limited to wetting or moist burlap. Cold vertical joints are any planned or unplanned construction joints that do not qualify as fresh joints.

Cold vertical joints may be formed through the use of an edging shoe after successful demonstration that the procedure meets the minimum joint density requirements of this section and the edging shoe produces a face with no more than an angle of 10 degrees from vertical. If the edging shoe is not used or cannot meet the specification requirements, remove a minimum of 6 inches along the entire edge by saw cutting the full depth of the RCC pavement. Saw cutting operations must not produce excessive raveling along the surface of the cut.

Prior to placing fresh RCC mixture against a compacted cold vertical joint, the joint shall be thoroughly cleaned of any loose or foreign material and in a moist condition immediately prior to placement. The joints between RCC pavement and concrete structures shall be treated as cold vertical joints.

Construct all contraction joints within RCC pavement in accordance with the plans and Article 700-11 of the *Standard Specifications*. Seal contraction joints in accordance with Article 700-12 (excluding 700-12 (B) Age of Pavement) of the *2018 Standard Specifications*.

(I) Opening to Traffic

Heavy truck traffic and other heavy equipment will not be allowed on the RCC pavement until representative concrete test cylinders achieve 3,000 psi and at least 3 days old. All compressive strength concrete test cylinders shall be made and tested in accordance with ASTM 1435 and AASHTO T22. However, limited automobile and light truck traffic may be allowed on the RCC as soon as the concrete is sufficiently cured to prevent significant marring.

No permanent traffic will be allowed on the pavement until construction of the joints, including all sawing, sealing, and curing that is required, has been completed.

Thickness Acceptance

The thickness of the pavement will be determined by measurement of cores. One core will be taken from each lot at a random location selected by the Engineer.

The thickness of the RCC pavement shall not deviate from that shown on the plans by more than minus 0.5 inches. When the measurement of any core is less than the plan thickness by more than 0.5 inches, the actual thickness of the pavement in this area will be determined by taking additional cores at not less than 10 foot intervals parallel to the center line in each direction from the affected location until a core is found in each direction which is not deficient by more than 0.5 inches. Areas found deficient in thickness by more than 0.5 inches will be removed full shoulder width and replaced with concrete of the thickness shown on the plans. No overlays shall be accepted.

Strength Acceptance

The minimum compressive strength of RCC field cylinder specimens shall be at least 4,500 psi. The RCC pay factor for pavement achieving a compressive strength in 28 days of 4,500 psi or greater is 100%. The pay factor for pavement achieving a compressive strength in 28 days between 3,500 psi and 4,500 psi is determined by the following formula:

$$\text{Pay Factor (\%)} = 100.0 - [0.05(4500 - \text{Compressive Strength})]$$

(pay factor rounded to nearest 0.1%)

If the average compressive strength of the three cores per Lot is less than 4500 psi, then the area will be evaluated in accordance with Article 105-3 of the *2018 Standard Specifications for Roads and Structures*.

Test Section

At least 7 days before the start of paving operations, construct a test section using the approved concrete mix design. Provide a minimum test section of 300 feet in length. Use the same equipment, materials, techniques, and personnel in the test section that will be used to construct the production RCC pavement. If approved by the Engineer, the test section may be incorporated into the production section.

The Engineer shall evaluate the following criteria from the test section:

- Adequacy of mixing plant to meet productivity requirements and produce consistent material.
- Maximum density directly behind the paver prior to roller compaction.
- Sequence of primary/ secondary roller passes (with and without vibration).
- Maximum density following roller compaction.
- Texture and surface finish acceptability.
- Integrity of proposed edging shoes, edge compaction, and jointing methods.
- RCC compressive strength based on cylinders and extracted cores tested at 7 and 28 days.

Verify the correlation between the compressive strength of extracted cores and compressive strength of field cylinder specimens. A representative area of the test section should be identified and samples of the material used to construct this area collected for the fabrication of cylinders. The final density of the subject area shall be determined and recorded.

DIAMOND GRINDING CONCRETE PAVEMENT

(4-15-08) (Rev 08-16-16)

SPI 7-9A

Description

Perform the work covered by this provision including but not limited to diamond grinding and regrinding concrete pavement to meet final surface acceptable smoothness requirements detailed in Article 710-7, selecting diamond tipped saw blades and configuration of cutting head; continual removal of residual slurry from pavement and disposal; furnishing all labor, materials, supplies, tools, equipment and incidentals as necessary. Perform this work on all new concrete pavement or as directed by the Engineer.

Prior to beginning any diamond grinding operations, schedule a pre-grind meeting with grinding subcontractor, Division Construction Engineer, Project Engineer, Area Roadway Engineer, State Pavement Construction Engineer, NCTA, representatives from the Roadside Environmental Unit and the Materials and Tests Unit.

Equipment

Use equipment with diamond tipped saw blades gang mounted on a power driven self-propelled machine with a minimum wheel base length of 15 feet that is specifically designed to smooth and texture Portland Cement Concrete pavement. Utilize equipment that does not cause ravels; aggregate fracture; spalls or disturbance to the longitudinal or transverse joints; or damage and/or strain to the underlying surface of the pavement. Should any of the above problems occur immediately suspend operations.

Provide a minimum 3 feet wide grinding head with 50 to 60 evenly spaced grooves per foot. Prior to designing the grinding head, evaluate the aggregate hardness of the concrete pavement and select the appropriate diamond size, diamond concentration and bond hardness for the individual saw blades.

Provide vacuuming equipment to continuously remove slurry residue and excess water from the pavement as part of the grinding operation. Transport slurry material off-site and dispose of this

material appropriately. Do not allow the slurry material to flow into a travel lane occupied by traffic or into any drainage facility.

Method of Construction

Grind the pavement surface to a uniform appearance with a high skid resistant longitudinal corduroy type texture. Provide grooves between 0.09 and 0.15 inches wide with the land area between the grooves between 0.06 and 0.13 inches wide. Ensure a ridge peak of approximately 0.0625 inches higher than the bottom of the grooves.

Begin and end diamond grinding at lines normal to the pavement centerline. Grind only in the longitudinal direction. All grooves and adjacent passes shall be parallel to each other with no variation. Completely lap adjacent passes with no unground surface remaining between passes and no overlap of more than 1½ inches. Adjacent passes shall be within 1/8 inch of the same height as measured with a 3 foot straightedge. Maintain positive cross-slope drainage for the duration of the grinding operation.

Grind all travel lanes to include auxiliary lanes, ramps and loops with not less than 98 percent of the specified surface being textured by grinding. Grinding of the bridge decks and concrete shoulders will not be required. Remove a minimum 0.0625 inches at all locations except dips. Extra grinding to eliminate minor depressions is not required. It is anticipated that extra grinding will be required on the high side of existing faults in the pavement. There shall be no ridge between lanes. In a separate operation, transition the grinding of any remaining ridges greater than 1/8 inch in height on the outside edge next to the shoulder or at a tie to an existing facility to the satisfaction of the Engineer.

Final surface testing is required on this project in accordance with Article 710-7 of the *2018 Standard Specifications*.

Disposal of Residual Slurry

Diamond grinding slurry disposal shall be in accordance with the Statewide Permit for Land Application of Diamond Grinding Slurry (DGS), Permit No. WQ0035749 dated June 3, 2014. Submit a slurry disposal plan to the Engineer detailing method of handling and disposing of slurry from the diamond grinding operation a minimum of 60 days prior to beginning the diamond grinding operation. Engineer shall review the slurry disposal plan. Plan must be accepted prior to beginning the diamond grinding operation. DGS shall be transported beyond the project limits to an approved permitted site. No additional payment will be made for transporting this slurry material for disposal.

Disposal options are:

- (A) Concrete grinding residues (CGR) that are not liquid and otherwise not hazardous may be disposed of in a municipal solid waste landfill or utilized as an alternate daily cover (ADC). The sanitary landfill operator that requests the use of this material as ADC shall contact the N.C. Department of Environmental Quality (DEQ) inspector for approval. The definition of a solid, for solid waste disposal purposes, is a material that passes a Paint

Filter test. CGR's may be eligible for disposal or use as ADC in an unlined sanitary landfill or a construction and demolition debris landfill. If CGR is disposed in an unlined-landfill, the Contractor shall submit samples of the material to a certified laboratory to verify that the CGR does not exceed Resource Conservation and Recovery Act (RCRA) regulatory limits for the following metals: Arsenic, Barium, Cadmium, Chromium, Lead, Mercury, Selenium and Silver.

- (B) Upon the Engineer's approval, dewatered CGR's may be beneficially reused within the DOT project boundary or areas under DOT control at agronomic rates suitable for the establishment of vegetation. Dewatered CGR's that meet the solid waste definition for inert debris, North Carolina General Statute 130A-290(a)(14), may also be used within the roadbed at rates approved by the Engineer for soil modification purposes. If CGR is disposed as beneficial reuse within DOT project boundaries, the Contractor shall submit samples of the material to a certified laboratory to verify that the CGR does not exceed RCRA regulatory limits for the following metals: Arsenic, Barium, Cadmium, Chromium, Lead, Mercury, Selenium and Silver.

To prevent the migration of any direct discharge from the diamond grinding machine DGS from entering a drainage inlet or structure, the contractor shall install coir fiber wattles and silt fence at the direction of the Engineer. Silt Fence shall be installed in accordance with Section 1605 of the NCDOT *2012 Standard Specifications*

SOUND BARRIER WALL

(3-6-15) (Rev. 5-24-18)

(A) DESCRIPTION

This work consists of furnishing concrete columns and all other materials; handling, transporting, fabricating, and storing materials; furnishing erection drawings, pile excavation, backfilling, erecting and installing the sound barrier wall members and all other materials as required by the plans developed by the Design-Build Team, the 2018 *Standard Specifications for Roads and Structures* and this Project Special Provision.

Unless otherwise approved by the Engineer, the Design-Build Team has a choice of ten or 15-foot pile spacing. Pile spacing greater than 15 feet will not be permitted. Provide consistent pile spacing the entire length of the wall. Use odd pile spacing, if necessary, only at the ends of the wall and at turning points, as approved by the Engineer.

Changes in top of wall elevations are permitted if gradual in accordance with the *Complete 540 Aesthetics Design Guide* provided by the NCTA. Elevation changes greater than one foot, if necessary, will be allowed only at the end of the wall. Top of wall elevation changes that result in a jagged appearance shall not be allowed. Unless otherwise approved by NCDOT, the wall shall adhere to the Design Noise Report developed by the Design-Build Team.

(B) ALTERNATE PILE SPACING

As an alternate, the Design-Build Team may submit plans for pile spacing greater than 10 feet and less than 15 feet for review and approval. A submittal reducing the post spacing shall include the material and design specifications. The submittal shall also include an elevation view depicting

the revised post spacing and proposed top of wall elevations. The proposed top of wall elevations shall be equal to or greater than the dimensions shown in the Design Noise Report developed by the Design-Build Team. The excavated hole diameter, excavation depth and reinforcing steel shall be equal to the amount required for 15-foot pile spacing. A variance in the reinforcing steel will be allowed for the length of horizontal and number of vertical reinforcement bars in the precast panel for the alternate pile spacing.

Submit two sets of detailed plans for review. Have a North Carolina Registered Professional Engineer check, seal and date the plans developed by the Design-Build Team and, when requested, calculations.

(C) MATERIALS AND FABRICATION

Provide materials and fabricate members in accordance with this Project Special Provision and the requirements of Division 10 of the 2018 *Standard Specifications for Roads and Structures*.

(D) CONSTRUCTION METHODS

Complete the final survey of existing ground profile after clearing the sound barrier wall area, but prior to submitting any Working Drawings. Submit the final groundline survey with the Working Drawings.

Excavate holes with the diameters shown on the plans developed by the Design-Build Team. Perform pile excavation to the depths shown on the aforementioned plans and install piles as shown on the plans developed by the Design-Build Team with a tolerance of ½-inch per foot from vertical. Backfill excavations with concrete after placing piles.

Pile Excavation - Use equipment of adequate capacity and capable of drilling through soil and non-soil including rock, boulders, debris, man-made objects and any other materials encountered. Blasting shall not be permitted to advance the excavation. Blasting for core removal shall only be permitted when approved by the Engineer. Dispose of drilling spoils in accordance with Section 802 of the 2018 *Standard Specifications for Roads and Structures* and as directed by the Engineer. Drilling spoils shall consist of all excavated material, including but not limited to water removed from the excavation either by pumping or drilling tools.

If unstable, caving or sloughing soils are anticipated or encountered, stabilize excavations with either slurry or steel casing. When using slurry, submit slurry details including product information, manufacturer's recommendations for use, slurry equipment information and written approval from the slurry supplier that the mixing water is acceptable before beginning drilling. When using steel casing, use either the sectional type or one continuous corrugated or non-corrugated piece. Steel casings shall consist of clean watertight steel of ample strength to withstand handling and driving stresses and the pressures imposed by concrete, earth or backfill. Use steel casings with an outside diameter equal to the hole size and a minimum wall thickness of ¼-inch.

Concrete Placement - Before placing concrete, center and support the pile in the excavation and check the water inflow rate in the excavation after any pumps have been removed. If the inflow rate is less than six inches per half hour, remove any water and free fall the concrete into the excavation. Ensure that concrete flows completely around the pile. If the water inflow rate is

greater than six inches per half hour, propose a concrete placement procedure to the Engineer. The Engineer shall approve the concrete placement procedure before placing any concrete.

Fill the excavation with Class A concrete in accordance with Section 1000 of the 2018 *Standard Specifications for Roads and Structures*, except as modified herein. Provide concrete with a slump of six to eight inches. Use an approved high-range water reducer to achieve this slump. Place concrete in a continuous manner and remove all casings.

DYNAMIC MESSAGE SIGN

(5-24-18)

(A) GENERAL REQUIREMENTS

Type A Dynamic Message Signs (DMSs) used on the State Highway System shall be preapproved on the current NCDOT ITS & Signals 2018 Qualified Products List (QPL) by the date of installation. Type B DMS shall meet all requirements herein. DMSs not preapproved will not be allowed for use on the project. To ensure compatibility with the existing DMS Control Software deployed in the State, furnish NTCIP compliant DMSs that are fully compatible with Daktronics, Inc. Vanguard Version 4.3 software (also referred to hereinafter as the “Control Software”). The QPL is available on the Department’s website. The QPL website is:

<https://connect.ncdot.gov/resources/safety/Pages/ITS-and-Signals-Qualified-Products.aspx>

DMS Requirements

Furnish and install DMSs compliant with UL standards 48, 50, and 879.

Add and configure the new DMSs in the system using the Control Software and computer system. Furnish, install, test, integrate and make fully operational the new DMSs at locations shown in the plans developed by the Design-Build Team.

Furnish operating DMS systems consisting of, but not limited to, the following:

- Large Walk-In Enclosure DMS for traffic management (Type A) off the Toll NC 540 corridor
 - Full Matrix, 27 pixels high and 90 pixels wide LED Walk-in DMS with 18” border
 - Mounting hardware to mount to proposed sign structure
- Large Front Access Color DMS for traffic management (Type B) on the Toll NC 540 corridor
 - Full Color Matrix, 96 pixels high and 368 pixels wide LED Front Access DMS
 - Mounting hardware to mount to proposed toll gantry
- DMS controllers, Uninterruptible Power Supplies (UPS), cabinets and accessories with interconnect and power cabling and conduit
- Branch circuit conductors and related equipment

- All other equipment and incidentals required for furnishing, installing, and testing the DMS system and system components

Use only UL listed and approved electronic and electrical components in the DMS system.

(B) MATERIALS

1. Environmental Requirements

Construct the DMS and DMS controller-cabinet so the equipment within shall be protected against moisture, dust, corrosion, and vandalism.

Design the DMS system to comply with the requirements of Section 2.1 (Environmental and Operating Standards) of NEMA TS 4-2005.

2. Full Matrix LED Dynamic Message Sign (DMS)

Legibility

Construct the DMS to display at least three lines of text that, when installed, are clearly visible and legible to a person with 20/20 corrected vision from a distance of 900 feet in advance of the DMS at an eye height of 3.5 feet along the axis.

- Type A - When displaying three lines, each line must display at least 15 equally spaced and equally sized alphanumeric individual characters. Each character must be at least 18 inches in height and composed from a luminous dot matrix. The entire LED matrix shall be at the minimum 27 pixels high and 90 pixels wide.
- Type B - When displaying the line, the line must display at least 18 equally spaced and equally sized alphanumeric individual characters. Each character must be at least 18 inches in height and composed from a luminous dot matrix. Provide an entire LED matrix that is a minimum of 96 pixels high and 368 pixels wide.

DMS Enclosure

The DMS enclosure construction shall comply with the requirements of Section 3 (Sign Mechanical Construction) of NEMA TS 4-2005 as it applies to Front Access and Walk-in enclosures. The following requirements complement TS 4-2005:

Construct the enclosure of welded aluminum type 6061-T6, 5052-H38, 5052-H34, or of an Engineer approved alternate at least 1/8-inch thick. Perform all welding of aluminum and aluminum alloys in accordance with the latest edition of AWS D1.2, Structural Welding Code - Aluminum. Continuously weld the seams using Gas Metal Arc Welding (GMAW).

Provide all exterior and interior DMS enclosure surfaces with natural, mill-finish aluminum. Remove all grind marks and discoloration from the surfaces.

Provide corrosion resistant nuts, bolts, washers, and other mounting and bonding parts and components used on the exterior of the DMS enclosure and ensure they are sealed against water intrusion.

Do not place a manufacturer name, logo, or other information on the front face of the DMS or shield visible to the motorist.

Provide power supply monitoring circuitry to detect power failure in the DMS and to automatically report this fault to the Control Software. This requirement shall be in addition to reporting power failure at the controller cabinet.

Do not paint the stainless-steel bolts on the Z-bar assembly used for mounting the enclosure.

- Type A – Construct the DMS with a metal walk-in enclosure excluding the face. Provide an aluminum walking platform inside the enclosure that is at least 28 inches wide. Ensure the width of the walking platform is free of obstructions to a height of 7 feet.

Provide one key lockable, hinged, gasket-sealed inspection door for service and maintenance along each side of the enclosure. Install one appropriately sized fire extinguisher within 12 inches of each maintenance door. Equip the DMS enclosure with internal fluorescent lighting controlled by timers installed close to each inspection door. Make certain no light emitted from the fluorescent tubes or any other light source inside the enclosure not comprising the display is leaked to the outside of the enclosure. Equip the door with a door-hold-open device. Install GFCI duplex utility receptacles every 6 feet along the width of the DMS in convenient locations for powered service tools.

- Type B – For front access signs, provide access internal to the sign housing by one of two methods. Method one is provide a hinged front face from the top to allow access to the interior of the sign and all of its components. Method two is the provision of a means to remove any and all display modules described below to access to the interior of the sign and all of its components.

DMS Interior Environment Control

Design the local field controller to monitor and control the interior DMS environment. Design environmental control to maintain the internal DMS temperature within +/- 10° F of the outdoor ambient temperature. Provide the DMS environmental control system with four primary subsystems as follows:

Internal Temperature Sensors – Provide the DMS with two internally mounted temperature sensors which are equipped with external thermocouples and which the Field Controller continuously monitors. Design the Field Controller to use this temperature information to determine when to activate and deactivate the environmental control systems described herein. Locate sensors on opposite ends of the upper 1/3 of the LED display matrix with their external

thermocouples attached to and making contact with an LED pixel circuit board. Design the thermocouple and LED board to be easily detachable, in the event that one of the units requires removal and replacement. Provide sensors capable of measuring temperatures from -40° F to +185° F. Design the Field Controller to automatically shut down the LED display whenever one or both sensors indicate that LED board temperature has exceeded +140° F, and to automatically restart the LED display whenever the suspect temperature falls below +130° F. Design both shutdown and re-start temperature thresholds to be user-programmable. Design the field controller to report sensor temperatures and DMS shutdown/re-start events to the DMS Control Software.

Housing Cooling System – Provide the DMS housing with a cooling system that circulates outside air into the DMS housing whenever the LED board temperature exceeds a user-programmable threshold. Provide this system with enough ventilation fans to exchange the internal DMS housing air volume at a minimum rate of 2 times per minute. Provide steel ball-bearing type fans. Mount fans in a line across the upper rear wall of the DMS housing to direct air out of the cabinet. Provide one filtered air intake port for each exhaust fan. Locate intake ports in a line across the lower rear wall of the DMS housing. Provide intake ports with a removable filter that will remove airborne particles measuring 500 microns in diameter and larger. Provide a filter that is of a size and style that is commercially readily available. Program the field controller to activate the DMS housing cooling system whenever the LED board temperature exceeds +90° F and to turn the cooling system off whenever LED board temperature falls below +85° F. On the DMS housing rear exterior wall, cover all air intake and exhaust ports on their top, front, and sides by an aluminum shroud fabricated from 0.090-inch aluminum sheeting. Taper the shrouds at the top. Securely fasten shrouds to the DMS housing, and provide gaskets at the interface to prevent water from entering the DMS. Design all air filters and fans to be removable from inside the DMS housing. Provide the DMS housing cooling system with an adjustable timer that will turn fans off after the set time has expired. Provide a timer that is adjustable to at least 4 hours, and locate it just inside the DMS housing door, within easy reach of a maintenance technician standing outside the DMS doorway.

LED Display Cooling System – Provide the DMS with an LED display cooling system which directs air across the LED display modules whenever LED board temperature exceeds a user-programmable threshold. Direct fan-forced air vertically across the backside of the entire LED display matrix using multiple ball-bearing fans. Program the field controller to activate the LED cooling fan system whenever LED board temperature exceeds +90° F and to deactivate the system whenever LED board temperature falls to +85° F. Locate cooling fans so as not to hinder removal of LED display modules and driver boards.

Front Face Panel Defog / Defrost System – Provide the DMS with a defog / defrost system which circulates warm, fan-forced air across the inside of the polycarbonate front face whenever LED board temperature falls below a user-

programmable threshold. Provide multiple steel ball-bearing fans that provide uniform airflow across the face panel. Program the field controller to activate the defog / defrost system whenever LED board temperature falls below +40° F and to deactivate the defog/defrost system whenever LED board temperature exceeds +106° F. Mount a 100-watt pencil-style heating element in front of each defog / defrost fan to warm the air directed across the DMS face. Design heating elements to be on only when the defog / defrost fans are on.

Install additional fans and / or heaters as needed to maintain the temperature inside the DMS enclosure within the operating temperature range of the equipment within the DMS enclosure as recommended by the equipment manufacturer(s).

Front Panel

Protect the DMS face with contiguous, weather-tight, removable panels. These panels shall be a polycarbonate material that are ultraviolet protected, have an antireflection coating, and are a minimum of 1/8- inch thick.

Furnish polycarbonate panels with the following characteristics:

- Tensile Strength, Ultimate: 10,000 PSI
- Tensile Strength, Yield: 9,300 PSI
- Tensile Strain at Break: 125%
- Tensile Modulus: 330,000 PSI
- Flexural Modulus: 330,000 PSI
- Impact Strength, Izod (1/8", notched): 17 ft-lbs/inch of notch
- Rockwell Hardness: M75, R118
- Heat Deflection Temperature Under Load: 264 PSI at 270° F and 66 PSI at 288° F
- Coefficient of Thermal Expansion: 3.9×10^{-5} in/in/F
- Specific Heat: 0.30 BTU/lb/F
- Initial Light Transmittance: 85% minimum
- Change in Light Transmittance, 3 years exposure in a Southern latitude: 3%
- Change in Yellowness Index, 3 years exposure in a Southern latitude: less than 5%

For substitutes, submit one 12" x 12" sample of the proposed material together with a description of the material attributes to the Engineer for review and approval. Install a .09" aluminum mask on the front of the panel (facing the motorists) that contains a circular opening for each LED pixel. Prime and coat the front side of the aluminum mask, which faces the viewing motorists, with automotive-grade flat black acrylic enamel paint or an approved equivalent. Guarantee all painted surfaces provide a minimum outdoor service life of 20 years.

Design the panels so they will not warp nor reduce the legibility of the characters. Differential expansion of the DMS housing and the front panel must not cause damage to any DMS component or allow openings for moisture or dust. Glare from

sunlight, roadway lighting, commercial lighting, or vehicle headlights must not reduce the legibility or visibility of the DMS. Install the panels so that a maintenance person can easily remove or open them for cleaning.

Display Modules

Assemble the modules onto the DMS assemblies contiguously to form a continuous matrix to display the required number of lines, characters, and character height.

Design display modules that are interchangeable and replaceable without using special tools. Provide plug-in type power and communication cables to connect to a display module.

Provide the module with an equal vertical and horizontal pitch between pixels, and columns that are perpendicular to the rows (i.e., no slant). Design each module to display:

- All upper and lower-case letters
- All punctuation marks
- All numerals 0 to 9
- Special user-created characters

Display upper-case letters and numerals over the complete height of the module. Optimize the LED grouping and mounting angle within a pixel for maximum readability.

Furnish two (2) spare display modules per each DMS installed for emergency restoration.

- Type A - Manufacture each display module with a standard number of pixels, not to exceed an array of 9 x 5, which can be easily removed.

Construct each display module as a rectangular array of 5 horizontal pixels by 7 to 9 vertical pixels.

- Type B - Manufacture each display module with a standard number of pixels, not to exceed an array of 24 x 16, which can be easily removed.

Construct each display module as a rectangular array of 16 horizontal pixels by 24 vertical pixels.

Discrete LEDs

Provide discrete LEDs with a nominal viewing cone of **30 degrees** with a half-power angle of 15 degrees measured from the longitudinal axis of the LED. Viewing cone tolerances shall be as specified in the LED manufacturer's product specifications and shall not exceed +/- 3 degrees half-power viewing angle of 30 degrees.

Provide LEDs that are untinted, non-diffused, high output solid state lamps utilizing indium gallium aluminum phosphide (InGaAlP) technology. No substitutions will be allowed.

Provide LEDs with a MTBF (Mean Time Before Failure) of at least 100,000 hours of permanent use at an operating point of 140° F or below at a specific forward current of 20mA. Discrete LED failure is defined as the point at which the LED's luminous intensity has degraded to 50% or less of its original level.

Obtain the LEDs used in the display from a single LED manufacturer that have a single part number. Obtain them from batches sorted for luminous output, where the highest luminosity LED is not more than fifty percent more luminous than the lowest luminosity LED when the LEDs are driven at the same forward current. Do not use more than two successive and overlapping batches in the LED display. Document the procedure to be used to comply with this requirement as part of the material submittal.

Individually mount the LEDs on circuit boards that are at least 1/16" thick FR-4 fiberglass, flat black printed circuit board in a manner that promotes cooling. Protect all exposed metal on both sides of the LED pixel board (except the power connector) from water and humidity exposure by a thorough application of acrylic conformal coating. Design the boards so bench level repairs to individual pixels, including discrete LED replacement and conformal coating repair is possible.

Operate the LED display at a low internal DC voltage not to exceed 24 Volts.

Design the LED display operating range to be -20° F to +14° F at 95% relative humidity, non-condensing.

Supply the LED manufacturer's technical specification sheet with the material submittals.

- Type A - Provide T1 3/4, 0.2-inch size LEDs that emit a true amber color at a wavelength of 590 ± 5 nm.
- Type B - Provide LEDs that emit a full color.

LED Power Supplies

Power the LED Display by means of multiple regulated switching DC power supplies that operate from 120 volts AC input power and have an output of 48 volts DC or less. Wire the supplies in a redundant parallel configuration that uses multiple power supplies per display. Provide the supplies with current sharing capability that allows equal amounts of current to their portion of the LED display. Provide power supplies rated such that if one supply fails the remaining supplies will be able to operate their portion of the display under full load conditions (i.e. all pixels on at maximum brightness) and at a temperature of 140° F.

Provide power supplies to operate within a minimum input voltage range of +90 to +135 volts AC and within a temperature range of -22° F to 140° F. Power supply output at 140° F must not deteriorate to less than 65% of its specified output at 70° F. Provide power supplies that are overload protected by means of circuit breakers, that have an efficiency rating of at least 75%, a power factor rating of at least .95, and are UL listed. Provide all power supplies from the same manufacturer and with the same model number. Design the power driver circuitry to minimize power consumption.

Design the field controller to monitor the operational status (normal or failed) of each individual power supply and can display this information on the Client Computer screen.

LED Pixels

A pixel is defined as the smallest programmable portion of a display module that consists of a cluster of closely spaced discrete LEDs.

Construct the pixels with two strings of LEDs. It is the manufacturer's responsibility to determine the number of LEDs in each string to produce the candela requirement as stated herein.

Ensure each pixel produces a luminous intensity of 40 Cd when driven with an LED drive current of 20 mA per string.

Power the LEDs in each pixel in strings. Use a redundant design so that the failure of an LED in one string does not affect the operation of any other string within the pixel. Provide the sign controller with the ability to detect the failure of any LED string and identify which LED string has failed. Submit a complete schematic of the LED power and driver circuits with the material submittals.

- Type A - Design pixel pitch to be a maximum of 66 mm.
- Type B - Design pixel pitch to be a maximum of 20 mm

Character Display

Design display modules to be easily removable without the use of tools. Position cooling fans so they do not prevent removal of an LED pixel board or driver board.

Use continuous current to drive the LEDs at the maximum brightness level. Design the light levels to be adjustable for each DMS / controller so the Engineer may set levels to match the luminance requirements at each installation site.

Design the controller to automatically detect failed LED strings or drivers and initiate a report of the event to the Control Software. Design the controller to be able to read the internal temperature of the DMS enclosure and the ambient temperature outside the DMS enclosure and report these to the Control Software.

Display Capabilities

- Type A & B - Design the DMS with at least the following message displays:
 - Static display
 - Flashing display with dynamic flash rates
 - At least two alternating static and/or flashing sequences (multi-page messages)

DMS Mini Controller

For Type A signs (only), furnish and install a mini controller inside the DMS that is interconnected with the main controller using a fiber optic cable, CAT-5 cable, or an approved alternate. The mini controller will enable a technician to perform all functions available from the main controller. Provide the mini controller with an LCD / keypad interface. Size the LCD display screen to allow preview of an entire one-page message on one screen. Provide a 4 X 4 keypad.

Alternatively, install an EIA/TIA-232E port inside the DMS enclosure to enable a maintenance technician to communicate with the DMS main controller and obtain access to and perform all functions of the main controller using a laptop computer.

2. DMS Enclosure Structure Mounting

Design the DMS enclosure supports to allow full access to the DMS enclosure inspection door. Mount the DMS enclosure according to the manufacturer's recommendations.

Submit plans developed by the Design-Build Team for the DMS enclosure, mounting description and calculations to the Engineer for approval. Have such calculations and drawings approved by a Professional Engineer registered in the state of North Carolina, and bear his or her signature, seal, and date of acceptance.

Provide removable lifting eyes or the equivalent on the DMS enclosure rated for its total weight to facilitate handling and mounting the DMS enclosure.

Design the DMS structure to conform to the applicable requirements of the AASHTO *LRFD Specifications for Structural Supports for Highway Signs, Luminaires and Traffic Signals*, 1st Edition, and the latest Interim Specifications, and the section titled "DMS Pedestal Structure" of these Project Special Provisions.

- Type A & B - Mount the DMS enclosure and interconnect system securely to the support structures.

Furnish and install U-bolt connections of hanger beams to overhead assembly truss chords with a double nut at each end of the U-bolt. Bring the double nuts tight against each other by the use of two wrenches.

3. DMS / DMS Controller Interconnect

Furnish and install all necessary cabling, conduit, and terminal blocks to connect the DMS and the DMS controller. Use approved manufacturer's specifications and the project plans developed by the Design-Build Team for cable and conduit types and sizes. Use fiber optic cable to interconnect sign and controller. Install fiber optic interconnect centers in the sign enclosure and cabinet to securely install and terminate the fiber optic cable. Submit material submittal cut sheets for the interconnect center.

4. DMS Controller and Cabinet

Furnish and install one DMS controller with accessories per DMS in a new equipment cabinet. Mount the controller cabinet on the DMS support structure. Install cabinet so that the height from the ground to the middle of the cabinet is four feet. Ensure a minimum of three-foot level working surface under each cabinet that provides maintenance technicians with a safe working environment.

Provide the DMS controller as a software oriented microprocessor and with resident software stored in non-volatile memory. The Control Software, controller and communications must comply with the NTCIP requirements identified in these Project Special Provisions. Provide sufficient non-volatile memory to allow storage of at least 500 multi-page messages and a test pattern program.

Furnish the controller cabinet with, but not limited to, the following:

- Power supply and distribution assembly
- Power line filtering hybrid surge protectors
- Radio Interference Suppressor
- Communications surge protection devices
- Industrial-Grade UPS system and local disconnect
- Microprocessor-based controller
- Display driver and control system (unless integral to the DMS)
- Serial interface port for local laptop computer
- Local user interface
- Interior lighting and duplex receptacle
- Adjustable shelves as required for components
- Temperature control system
- All interconnect harnesses, connectors, and terminal blocks
- All necessary installation and mounting hardware

Furnish the DMS controller and associated equipment completely housed in a NEMA 3R cabinet made from 5052 H32 sheet aluminum at least 1/8" thick. Use natural aluminum

cabinets. Perform all welding of aluminum and aluminum alloys in accordance with the latest edition of AWS D1.2, Structural Welding Code - Aluminum. Continuously weld the seams using Gas Metal Arc Welding (GMAW).

Slant the cabinet roof away from the front of the cabinet to prevent water from collecting on it.

Do not place a manufacturer name, logo or other information on the faces of the controller cabinet visible to the motorist.

Provide cabinets capable of housing the components and sized to fit space requirement. Design the cabinet layout for ease of maintenance and operation, with all components easily accessible. Submit a cabinet layout plan for approval by the Engineer.

Locate louvered vents with filters in the cabinet to direct airflow over the controller and auxiliary equipment, and in a manner that prevents rain from entering the cabinet. Fit the inside of the cabinet, directly behind the vents, with a replaceable, standard size, commercially available air filter of sufficient size to cover the entire vented area.

Provide a torsionally rigid door with a continuous stainless-steel hinge on the side that permits complete access to the cabinet interior. Provide a gasket as a permanent and weather resistant seal at the cabinet door and at the edges of the fan / exhaust openings. Use a non-absorbent gasket material that will maintain its resiliency after long term exposure to the outdoor environment. Construct the doors so that they fit firmly and evenly against the gasket material when closed. Provide the cabinet door with louvered vents and air filters near the bottom as described in the paragraph above.

The cabinet shall contain a full-height standard EIA 19-inch rack. The rack shall be secured within the cabinet by mounts at the top and bottom.

The rack shall contain a minimum of one (1) pullout drawer. The drawer shall be suitable for storing manuals and small tools, such as screwdrivers. The drawer shall be able to latch in the out position to function as a laptop / utility shelf.

Provide a convenient location on the inside of the door to store the cabinet wiring diagrams and other related cabinet drawings. Provide a Corbin #2 main door lock made of non-ferrous or stainless-steel material. Key all locks on the project alike, and provide 10 keys to the Engineer. In addition, design the handle to permit pad-locking.

Provide the interior of the cabinet with ample space for housing the controller and all associated equipment and wiring; use no more than 75% of the useable space in the cabinet. Provide ample space in the bottom of the cabinet for the entrance and exit of all power, communications, and grounding conductors and conduit.

Arrange the equipment so as to permit easy installation of the cabling through the conduit so that they will not interfere with the operation, inspection, or maintenance of the unit. Provide adjustable metal shelves, brackets, or other support for the controller unit and auxiliary equipment. Leave a three-inch minimum clearance from the bottom of the cabinet to all equipment, terminals, and bus bars.

Provide power supply monitoring circuitry to detect power failure and to automatically report the occurrence to the Control Software.

Install two 15-watt fluorescent light strips with shields, one in the top of the cabinet and the other under the bottom shelf. Design both lights to automatically turn on when the cabinet door is opened and turn off when the door closes.

Mount and wire a 120V (+10%) GFCI duplex receptacle of the 3-wire grounding type in the cabinet in a location that presents no electrical hazard when used by service personnel for the operation of power tools and work lights.

No cabinet resident equipment shall utilize the GFCI receptacle. Furnish one spare non-GFCI receptacle for future equipment.

Mount a bug-proof and weatherproof thermostatically controlled fan and safety shield in the top of the cabinet. Size the fan to provide at least for two air exchanges per minute. Fuse the fan at 125% of the capacity of the motor. The magnetic field of the fan motor must not affect the performance of the control equipment. Use a fan thermostat that is manually adjustable to turn on between 80°F and 160°F with a differential of not more than 10° F between automatic turn-on and turn-off. Mount it in an easily accessible location, but not within 6 inches of the fan.

Install additional fans and/or heaters as needed to maintain the temperature inside the cabinet within the operating temperature range of the equipment within the cabinet as recommended by the equipment manufacturer(s).

Wiring

The requirements stated herein apply wherever electrical wiring is needed for any DMS system assemblies and subassemblies such as controller cabinet, DMS enclosure, electrical panel boards etc.

Neatly arrange and secure the wiring inside the cabinet. Where cable wires are clamped to the walls of the control cabinet, provide clamps made of nylon, metal, plastic with rubber or neoprene protectors, or similar. Lace and jacket all harnesses, or tie them with nylon tie wraps spaced at 6 inches maximum to prevent separation of the individual conductors.

Individually and uniquely label all conductors. Ensure all conductor labels are clearly visible without moving the conductor. Connect all terminal conductors to the terminal strip in right angles. Remove excess conductor before termination of the conductor. Mold the conductor in such a fashion as to retain its relative position to the terminal strip if removed from the strip. Do not run a conductor across a work surface with the exception of connecting to that work surface. No conductor bundles can be supported by fasteners that support work surfaces. Install all connectors, devices and conductors in accordance to manufacturer's guidelines. Comply with the latest NEC guideline in effect during installation. No conductor or conductor bundle may hang loose or create a snag hazard. Protect all conductors from damage. Ensure all solder joints are completed using industry accepted

practices and will not fail due to vibration or movement. Protect lamps and control boards from damage.

No splicing will be allowed for feeder conductors and communication cables from the equipment cabinet to the DMS enclosure.

Insulate all conductors and live terminals so they are not hazardous to maintenance personnel.

Route and bundle all wiring containing line voltage AC and / or shield it from all low voltage control circuits. Install safety covers to prevent accidental contact with all live AC terminals located inside the cabinet.

Use industry standard, keyed-type connectors with a retaining feature for connections to the controller.

Label all equipment and equipment controls clearly.

Supply each cabinet with one complete set of wiring diagrams that identify the color-coding or wire tagging used in all connections. Furnish a water-resistant packet adequate for storing wiring diagrams, operating instructions, and maintenance manuals with each cabinet.

Power Supply and Circuit Protection

Design the DMS and controller for use on a system with a line voltage of $120V \pm 10\%$ at a frequency of $60 \text{ Hz} + 3 \text{ Hz}$. Under normal operation, do not allow the voltage drop between no load and full load of the DMS and its controller to exceed 3% of the nominal voltage.

Blackout, brownout, line noise, chronic over-voltage, sag, spike, surge, and transient effects are considered typical AC voltage defects. Protect the DMS system equipment so that these defects do not damage the DMS equipment or interrupt their operation. Equip all cabinets with devices to protect the equipment in the cabinet from damage due to lightning and external circuit power and current surges.

Circuit Breakers

Protect the DMS controller, accessories, and cabinet utilities with thermal magnetic circuit breakers. Provide the controller cabinet with a main circuit breaker sized according to the NEC. Use appropriately sized branch circuit breakers to protect the controller and accessories and for servicing DMS equipment and cabinet utilities.

Surge Suppressor

Install and clearly label filtering hybrid power line surge protectors on the load side of the branch circuit breakers in a manner that permits easy servicing. Ground and electrically bond the surge protector to the cabinet within 2 inches.

provide power line surge protector that meets the following requirements:

Peak surge current occurrences	20 minimum
Peak surge current for an 8 x 20 microsecond wave-shape	50,000 amperes
Energy Absorption	> 500 Joules
Clamp voltage	240 volts
Response time	<1 nanosecond
Minimum current for filtered output	15 amperes for 120VAC *
Temperature range	-40° F to +158° F

*Capable of handling the continuous current to the equipment

Radio Interference Suppressor

Provide each controller cabinet with sufficient electrical and electronic noise suppression to enable all equipment in it to function properly. Provide one or more radio interference suppressors (RIS) connected between the stages of the power line surge suppressor that minimize interference generated in the cabinet in both the broadcast and the aircraft frequencies. Each RIS must provide a minimum attenuation of 50 decibels over a frequency range of 200 KHz to 75 MHz. Clearly label the suppressor(s) and size them at least at the rated current of the main circuit breaker but not less than 50 amperes.

Provide RIS that are hermetically sealed in a substantial metal case which is filled with a suitable insulating compound and have nickel-plated 10/24 brass stud terminals of sufficient external length to provide space to connect #8 AWG wires. Mount them so that the studs cannot be turned in the case. Properly insulate ungrounded terminals from each other, and maintain a surface linkage distance of not less than ¼” between any exposed current conductor and any other metallic parts. The terminals must have an insulation factor of 100-200 MΩ, dependent on external circuit conditions. Use RIS designed for 120 VAC ± 10%, 60Hz, and which meet the standards of UL and the Radio Manufacturers Association.

Communications Surge Protector

Equip the cabinet with properly labeled hybrid data line surge protectors that meet the following general requirements:

Surge current occurrences at 2000 ampere, 8 x 20 microsecond waveform	> 80
Surge current occurrences at 400 ampere, 10x700 microsecond waveform	> 80
Peak surge current for 8 x 20 microsecond waveform	10,000 A (2500 A/line)
Peak surge current for 10x700 microsecond waveform	500 A/line
Response time	< 1 nanosecond
Series resistance	< 15 Ω
Average capacitance	1500 pF
Temperature range	-10° F to 150° F
Clamp Voltage	As required to match equipment in application

Lightning Arrester

Protect the system with an UL-approved lightning arrester installed at the main service disconnect. It shall meet the following requirements:

Type of design	Silicon Oxide Varistor
Voltage	120 / 240 Single phase, 3 wires
Maximum current	100,000 amps
Maximum energy	3000 joules per pole
Maximum number of surges	Unlimited
Response time one milliamp test	5 nanoseconds
Response time to clamp 10,000 amps	10 nanoseconds
Response time to clamp 50,000 amps	25 nanoseconds
Leak current at double the rated voltage	None
Ground Wire	Separate

Uninterruptible Power Supply (UPS)

Provide the cabinet with an industrial grade power conditioning UPS unit to supply continuous power to operate the equipment connected to it if the primary power fails. The UPS must detect a power failure and provide backup power within 20 milliseconds. Transition to the UPS source from primary power must not cause loss of data or damage to the equipment being supplied with backup power. Provide

an UPS with at least three outlets for supplying conditioned AC voltage to the DMS controller. Provide a unit to meet the following requirements:

- Input Voltage Range: 120VAC +12%, -25%
- Power Rating: 1000 VA, 700 Watts
- Input Frequency: 45 to 65 Hz
- Input Current: 7.2A
- Output Voltage: 120VAC +/- 3%
- Output Frequency: 50/60 +/-1 Hz
- Output Current: 8.3A
- Output Crest Factor Ratio: @50% Load Up to 4.8:1
@75% Load Up to 3.2:1
@100% Load Up to 2.4:1
- Output THD: 3% Max. (Linear)
5% Max. (Non-Linear)
- Output Overload: 110% for 10 min; 200% for 0.05 sec.
- Output Dynamic Response: +/- 4% for 100% Step Load Change
0.5 ms Recovery Time.
- Output Efficiency @ 100% Load:90% (Normal Mode)
- Operating Temperature: -40° F to +165° F
- Humidity: 0% to 95% Non-condensing
- Remote Monitoring Interface: RS-232
- Protection: Input/Output Short Circuit
Input/Output Overload
Excessive Battery Discharge
- Specifications: UL1778, FCC Class A, IEEE 587

Provide a UPS unit capable of supplying 30 minutes of continuous backup power to the equipment connected to it when this equipment is operating at full load.

Controller Communications Interface

Provide the controller with the following interface ports:

- An EIA/TIA-232E port for remote communication using NTCIP
- An 10/100 Ethernet port for remote communication using NTCIP

- An EIA/TIA-232E port for onsite access using a laptop
- An EIA/TIA-232E auxiliary port for communication with a field device such as a UPS
- Fiber-optic ports for communication with the sign
- RJ45 ports for communication with the sign using CAT-5 cable
- RJ45 ports for communication with mini-controller located inside the sign enclosure (Type A signs only)

Controller Local User Interface

Provide the controller with a Local User Interface (LUI) for at least the following functions:

- On / Off Switch: controls power to the controller.
- Control Mode Switch: for setting the controller operation mode to either remote or local mode.
- LCD Display and Keypad: Allow user to navigate through the controller menu for configuration (display, communications parameter, etc.) running diagnostics, viewing peripherals status, message creation, message preview, message activation, and etc. Furnish a LCD display with a minimum size of 240x64 dots with LED back light.

Controller Address

Assign each DMS controller a unique address. Preface all commands from the Control Software with a particular DMS controller address. The DMS controller compares its address with the address transmitted; if the addresses match, then the controller processes the accompanying data.

Controller Functions

Design the DMS controller to continuously control and monitor the DMS independent of the Control Software. Design the controller to display a message on the sign sent by the Control Software, a message stored in the sign controller memory, or a message created on-site by an operator using the controller keypad.

Provide the DMS controller with a watchdog timer to detect controller failures and to reset the microprocessor, and with a battery backed-up clock to maintain an accurate time and date reference. Set the clock through an external command from the Control Software or the Local User Interface.

DMS Controller Memory

Furnish each DMS controller with non-volatile memory. Use the non-volatile memory to store and reprogram at least one test pattern sequence and 500 messages containing a minimum of two pages of 45 characters per page. The Control

Software can upload messages into and download messages from each controller's non-volatile memory remotely.

Messages uploaded and stored in the controller's non-volatile memory may be erased and edited using the Control Software and the controller. New messages may be uploaded to and stored in the controller's non-volatile memory using the Control Software and the controller.

5. Photo-Electric Sensors

Install three photoelectric sensors with ½ inch minimum diameter photosensitive lens inside the DMS enclosure. Use sensors that will operate normally despite continual exposure to direct sunlight. Place the sensors so they are accessible and field adjustable. Point one sensor north or bottom of the sign. Place the other two, one on the back wall and one on the front wall of the sign enclosure. Alternate designs maybe accepted, provided the sensor assemblies are accessible and serviceable from inside the sign enclosure.

Provide controls so that the Engineer can field adjust the following:

- The light level emitted by the pixels elements in each Light Level Mode.
- The ambient light level at which each Light Level Mode is activated.

6. Equipment List

Provide a general description of all equipment and all information necessary to describe the basic use or function of the major system components. Include a general "block diagram" presentation. Include tabular charts listing auxiliary equipment, if any is required. Include the nomenclature, physical and electrical characteristics, and functions of the auxiliary equipment unless such information is contained in an associated manual; in this case include a reference to the location of the information. Include an itemized list of equipment costs.

Include a table itemizing the estimated average and maximum power consumption for each major piece of equipment.

7. Physical Description

Provide a detailed physical description of size, weight, center of gravity, special mounting requirements, electrical connections, and all other pertinent information necessary for proper installation and operation of the equipment.

8. Parts List

Provide a parts list that contains all information needed to describe the characteristics of the individual parts, as required for identification. Include a list of all equipment within a group and a list of all assemblies, sub-assemblies, and replacement parts of all units. Arrange this data in a table, in alpha-numerical order of the schematic reference symbols,

which gives the associated description, manufacturer's name, and part number, as well as alternate manufacturers and part numbers. Provide a table of contents or other appropriate grouping to identify major components, assemblies, etc.

9. Character Set Submittal

Submit an engineering drawing of the DMS character set including 26 upper case and lower-case letters, 10 numerals, an asterisk (*), a dash, a plus sign (+), a designated lane diamond, a slash, an ampersand, and arrows at 0, 45, 90, 135, 180, 225, 270, and 315 degrees.

10. Wiring Diagrams

Provide a wiring diagram for each DMS and each controller cabinet, as well as interconnection wiring diagrams for the system as a whole.

Provide complete and detailed schematic diagrams to component level for all DMS assemblies and subassemblies such as driver boards, control boards, DMS controller, power supplies, etc. Ensure that each schematic enables an electronics technician to successfully identify any component on a board or assemblies and trace its incoming and outgoing signals.

11. Routine of Operation

Describe the operational routine, from necessary preparations for placing the equipment into operation to securing the equipment after operation. Show appropriate illustrations with the sequence of operations presented in tabular form wherever applicable. Include in this section a total list of the test instruments, aids and tools required to perform necessary measurements and measurement techniques for each component, as well as set-up, test, and calibration procedures.

12. Maintenance Procedures

Specify the recommended preventative maintenance procedures and checks at pre-operation, monthly, quarterly, semi-annual, annual, and "as required" periods to assure equipment operates reliably. List specifications (including tolerances) for all electrical, mechanical, and other applicable measurements and / or adjustments.

13. Repair Procedures

Include in this section all data and step-by-step procedures necessary to isolate and repair failures or malfunctions, assuming the maintenance technicians are capable of analytical reasoning using the information provided in the section titled "Wiring Diagrams and Theory of Operation."

Describe accuracy, limits, and tolerances for all electrical, physical, or other applicable measurements. Include instructions for disassembly, overhaul, and re-assembly, with shop specifications and performance requirements.

Give detailed instructions only where failure to follow special procedures would result in damage to equipment, improper operation, danger to operating or maintenance personnel, etc. Include such instructions and specifications only for maintenance that specialized technicians and engineers in a modern electromechanical shop would perform. Describe special test set-up, component fabrication, and the use of special tools, jigs, and test equipment.

14. Field Trial

At the request of the Engineer, supply a three-character demonstration module with characters of the size and type specified for the project, an appropriate control device and power supply to allow character display within 30 working days of the request. Perform a field trial on this module at a time and location selected by the Engineer.

This trial will allow the Engineer or his selected representatives to test the readability of the DMS at the maximum distance required for specified character size. Test the module with the sun directly above the DMS, and near the horizon in front of and behind the DMS (washout and back-lit conditions).

(A) CONSTRUCTION METHODS

1. Description

This article establishes practices and procedures and gives minimum standards and requirements for the installation of Dynamic Message Sign systems, auxiliary equipment and the construction of related structures.

Provide electrical equipment described in this specification that conforms to the standards of NEMA, UL, or Electronic Industries Association (EIA), wherever applicable. Provide connections between controllers and electric utilities that conform to NEC standards. Express wire sizes according to the American Wire Gauge (AWG).

Provide stainless steel screws, nuts, and locking washers in all external locations. Do not use self-tapping screws unless specifically approved by the Engineer. Use parts made of corrosion-resistant materials, such as plastic, stainless steel, brass, or aluminum. Use construction materials that resist fungus growth and moisture deterioration. Separate dissimilar metals by an inert dielectric material.

2. Layout

The Engineer will establish the actual location of each Dynamic Message Sign assembly. It is the Design-Build Team's responsibility to ensure proper elevation, offset, and orientation of all DMS assemblies. The location of service poles as well as conduit lengths shown in the plans developed by the Design-Build Team, are approximate based on available project data. Make actual field measurements to place conduit and equipment at the required location.

3. Construction Submittal

When the work is complete, submit "As-Built" Plans, inventory sheets, and any other data required by the Engineer to show the details of actual construction and installation and any modifications made during installation.

The "As-Built" Plans shall show: the DMS, controller, and service pole locations; DMS enclosure and controller cabinet wiring layouts; and wire and conduit routing. Show all underground conduits and cables dimensioned from fixed objects

Include detailed drawings that identify the routing of all conductors in the system by cable type, color code, and function. Clearly label all equipment in the DMS system, controller cabinet, and DMS enclosure.

4. Conduit

Install the conduit system in accordance with Section 1715 of the 2018 *Standard Specifications for Roads and Structures* and NEC requirements for an approved watertight raceway.

Make bends in the conduit so as not to damage it or change its internal diameter. Install watertight and continuous conduit with as few couplings as standard lengths permit.

Clean conduit before, during, and after installation. Install conduit in such a manner that temperature changes will not cause elongation or contraction that might damage the system.

Attach the conduit system to and install along the structural components of the DMS structure assemblies with beam clamps or stainless-steel strapping. Install strapping according to the strapping manufacturer's recommendations. Do not use welding or drilling to fasten conduit to structural components. Space the fasteners at no more than 4 feet for conduit 1.5 inches and larger or 6 feet for conduit smaller than 1.25 inches. Place fasteners no more than 3 feet from the center of bends, fittings, boxes, switches, and devices.

Locate underground conduit as shown in the project plans developed by the Design-Build Team in a manner consistent with these Project Special Provisions.

Do not exceed the appropriate fill ratio on all cable installed in conduit as specified in the NEC.

5. Wiring Methods

Do not pull permanent wire through a conduit system until the system is complete and has been cleaned.

Color-code all conductors per the NEC. Use approved marking tape, paint, sleeves or continuous colored conductors for No. 8 AWG and larger. Do not mark a white conductor in a cable assembly any other color.

Bury underground circuits at the depth shown in the project plans developed by the Design-Build Team and surround it with at least 3 inches of sand or earth back-fill free of rocks and debris. Compact backfill in 6 inch layers. Do not splice underground circuits unless specifically noted in the project plans developed by the Design-Build Team and approved by the Department.

6. Equipment and Cabinet Mounting

Mount equipment securely at the locations shown in the project plans developed by the Design-Build Team, in conformance with the dimensions shown. Install fasteners as recommended by the manufacturer and space them evenly. Use all mounting holes and attachment points for attaching DMS enclosures and controller cabinets to the structures.

Drill holes for expansion anchors of the size recommended by the manufacturer of the anchors and thoroughly clean them of all debris.

Provide one key-operated, pin tumbler, dead bolt padlock, with brass or bronze shackle and case, conforming to Military Specification MIL-P-17802E (Grade I, Class 2, Size 2, Style A) for each electrical panel and switch on the project. Key all padlocks alike, and provide 10 keys to the Engineer.

Provide cabinets with all mounting plates, anchor bolts, and any other necessary mounting hardware in accordance with these Project Special Provisions and the project plans developed by the Design-Build Team.

Seal all unused conduit installed in cabinets at both ends to prevent water and dirt from entering the conduit and cabinet with approved sealing material.

Install a ground bushing attached inside the cabinet on all metal conduits entering the cabinet. Connect these ground bushings to the cabinet ground bus.

7. Work Site Clean-Up

Clean the site of all debris, excess excavation, waste packing material, wire, etc. Clean and clear the work site at the end of each workday. Do not throw waste material in storm drains or sewers.

NTCIP REQUIREMENTS

(1-2-18)

DB 08-04

This section defines the detailed NTCIP requirements for the DMSs covered by these Project Special Provisions and the project plans developed by the Design-Build Team.

(A) REFERENCES

This specification references several standards through their NTCIP designated names. The following list provides the full reference to the current version of each of these standards.

Implement the most recent version of the standard including any and all Approved or Recommended Amendments to these standards for each NTCIP Component covered by these project specifications.

Table 1: NTCIP Standards

Abbreviated Number	Full Number	Title
NTCIP 1101	NTCIP 1101:1997	<i>Simple Transportation Management Framework</i>
NTCIP 1201	NTCIP 1201:1997	<i>Global Object Definitions</i>
NTCIP 1203	NTCIP 1203:1997	<i>Object Definitions for Dynamic Message Signs</i>
NTCIP 2001	NTCIP 2001:1997	<i>Class B Profile</i>
NTCIP 2101	NTCIP 2101	<i>SP-PMPP/232 Subnet Profile for PMPP over RS-232</i>
NTCIP 2102	NTCIP 2102	<i>SP-PMPP/FSK Subnet Profile for PMPP over FSK Modem</i>
NTCIP 2103	NTCIP 2103	<i>SP-PPP/232 Subnetwork Profile for PPP over RS232 (Dial Up)</i>
NTCIP 2104	NTCIP 2104	<i>SP-Ethernet Subnet Profile for Ethernet</i>
NTCIP 2201	NTCIP 2201	<i>TP-Null Transport Profile</i>
NTCIP 2202	NTCIP 2202	<i>TP-Internet Internet Transport Profile (TCP/IP and UDP/IP)</i>
NTCIP 2301	NTCIP 2301	AP-STMF AP for Simple Transportation Management Framework

(B) GENERAL REQUIREMENTS**1. Subnet Level**

Ensure each serial port on each NTCIP Component supports NTCIP 2103 over a dial-up connection with a contractor-provided external modem with data rates of 28.8 kbps, 19.2 kbps, 14.4 kbps, 9600 bps, 4800 bps, 2400 bps, 1200 bps, 600 bps, and 300 bps. Enable the NTCIP Component to make outgoing and receive incoming calls as necessary and support the following modem command sets:

- Hayes AT - Command Set
- MNP5
- MNP10
- V.42bis

Ensure each serial port on each NTCIP Component supports NTCIP 2103 over a null-modem connection with data rates of 19.2 kbps, 14.4 kbps, 9600 bps, 4800 bps, 2400 bps, 1200 bps, 600 bps, and 300 bps.

Ensure each serial port on each NTCIP Component supports NTCIP 2101 with data rates of 9600 bps, 4800 bps, 2400 bps, 1200 bps, 600 bps, and 300 bps.

Ensure NTCIP components support NTCIP 2102 and NTCIP 2104.

NTCIP Components may support additional Subnet Profiles at the manufacturer's option. At any one time, make certain only one Subnet Profile is active on a given serial port of the NTCIP Component. Ensure the NTCIP Component can be configured to allow the field technician to activate the desired Subnet Profile and provide a visual indication of the currently selected Subnet Profile.

2. Transport Level

Ensure each NTCIP Component complies with NTCIP 2201 and 2202.

NTCIP Components may support additional Transport Profiles at the manufacturer's option. Ensure Response datagrams use the same Transport Profile used in the request. Ensure each NTCIP Component supports the receipt of datagrams conforming to any of the identified Transport Profiles at any time.

3. Application Level

Ensure each NTCIP Component complies with NTCIP 1101 and 2301 and meets the requirements for Conformance Level 1 (NOTE - See Amendment to standard).

Ensure each NTCIP Component supports SNMP traps. An NTCIP Component may support additional Application Profiles at the manufacturer's option. Ensure Responses use the same Application Profile used by the request. Ensure each NTCIP Component supports the receipt of Application data packets at any time allowed by the subject standards.

4. Information Level

Guarantee each NTCIP Component provides Full, Standardized Object Range Support of all objects required by these Special Provisions unless otherwise indicated below. Make certain the maximum Response Time for any object or group of objects is 200 milliseconds.

Design the DMS to support all mandatory objects of all mandatory Conformance Groups as defined in NTCIP 1201 and NTCIP 1203. Table 2 indicates the modified object requirements for these mandatory objects.

Table 2: Modified Object Ranges for Mandatory Objects

Object	Reference	Project Requirement
ModuleTableEntry	NTCIP 1201 Clause 2.2.3	Contains at least one row with moduleType equal to 3 (software). The moduleMake specifies the name of the manufacturer, the moduleModel specifies the manufacturer's name of the component and the modelVersion indicates the model version number of the component.
MaxGroupAddresses	NTCIP 1201 Clause 2.7.1	At least 1
CommunityNamesMax	NTCIP 1201 Clause 2.8.2	At least 3
DmsNumPermanentMsg	NTCIP 1203 Clause 2.6.1.1.1.1	At least 1*
DmsMaxChangeableMsg	NTCIP 1203 Clause 2.6.1.1.1.3	At least 21
DmsFreeChangeableMemory	NTCIP 1203 Clause 2.6.1.1.1.4	At least 20 when no messages are stored.
DmsMessageMultiString	NTCIP 1203 Clause 2.6.1.1.1.8.3	The DMS supports any valid MULTI string containing any subset of those MULTI tags listed in Table 4

DmsControlMode	NTCIP 1203 Clause 2.7.1.1.1.1	Support at least the following modes: Local External central Central Override
----------------	----------------------------------	---

*** Ensure the Permanent Messages display the content shown in Table 3.**

Ensure the sign blanks if a command to display a message contains an invalid Message CRC value for the desired message.

Table 3: Content of Permanent Messages

Permanent Message Number	Description
1	Permanent Message # 1 blanks the display (i.e. consists of an empty MULTI string). It has a run-time priority of one (1)

Table 4: Required MULTI Tags

Code	Feature
f1	field 1 - time (12hr)
f2	field 2 - time (24hr)
f8	field 8 – day of month
f9	field 9 – month
f10	field 10 - 2-digit year
f11	field 11 - 4-digit year
fl (and /fl)	flashing text on a line by line basis with flash rates controllable in 0.5 second increments.
fo	Font
jl2	Justification – line – left
jl3	Justification – line – center
jl4	Justification – line – right
jl5	Justification – line – full
jp2	Justification – page – top
jp3	Justification – page – middle
jp4	Justification – page – bottom

Mv	moving text
Nl	new line
Np	new page, up to 2 instances in a message (i.e., up to 3 pages/frames in a message counting first page)
Pt	page times controllable in 0.5 second increments.

The NTCIP Component implements all mandatory and optional objects of the following optional conformance groups with FSORS.

Test Heading

a. Time Management

As defined in NTCIP 1201

b. Timebase Event Schedule

As defined in NTCIP 1201. The following list indicates the modified object requirements for this conformance group.

Table 5: Modified Object Ranges for the Timebase Event Schedule Conformance Group

Object	Reference	Project Requirement
MaxTimeBaseScheduleEntries	NTCIP 1201 Clause 2.4.3.1	At least 28
maxDayPlans	NTCIP 1201 Clause 2.4.4.1	At least 14
maxDayPlanEvents	NTCIP 1201 Clause 2.4.4.2	At least 10

c. Report

As defined in NTCIP 1201. The following list indicates the modified object requirements for this conformance group.

Table 6: Modified Object Ranges for the Report Conformance Group

Object	Reference	Project Requirement
maxEventLogConfigs	NTCIP 1201 Clause 2.5.1	At least 50
eventConfigurationMode	NTCIP 1201 Clause 2.4.3.1	The NTCIP Component supports the following Event Configuration Modes:

		onChange greaterThanValue smallerThanValue
MaxEventLogSize	NTCIP 1201 Clause 2.5.3	At least 200
MaxEventClasses	NTCIP 1201 Clause 2.5.5	At least 16

d. PMPP**e. Font Configuration**

As defined in NTCIP 1203. The following list indicates the modified object requirements for this conformance group.

Table 7: Modified Object Ranges for the Font Configuration Conformance Group

Object	Reference	Project Requirement
NumFonts	NTCIP 1203 Clause 2.4.1.1.1.1	At least 4*
MaxFontCharacters	NTCIP 1203 Clause 2.4.1.1.1.3	At least 127**

* Upon delivery, the first font is a standard 18” font. The second font is a double-stroke 18” font. The third font is a 28” font. The fourth font is empty.

** Upon delivery, the first three font sets are configured in accordance with the ASCII character set for the following characters:

- “A” thru “Z”- All upper-case letters.
- “0” thru “9”- All decimal digits.
- Space (i.e., ASCII code 0x20).
- Punctuation marks shown in brackets [. , ! ? - ‘ ’ “ ” / ()]
- Special characters shown in brackets [# & * + < >]

f. DMS Configuration

As defined in NTCIP 1203.

g. MULTI Configuration

As defined in NTCIP 1203. The following list indicates the modified object requirements for this conformance group.

Table 8: Modified Object Ranges for the MULTI Configuration Conformance Group

Object	Reference	Project Requirement
DefaultBackgroundColor	NTCIP 1203 Clause 2.5.1.1.1.1	The DMS supports the following background colors: black
DefaultForegroundColor	NTCIP 1203 Clause 2.5.1.1.1.2	The DMS supports the following foreground colors: amber
DefaultJustificationLine	NTCIP 1203 Clause 2.5.1.1.1.6	The DMS supports the following forms of line justification: left center right full
defaultJustificationPage	NTCIP 1203 Clause 2.5.1.1.1.7	The DMS supports the following forms of page justification: top middle bottom
defaultPageOnTime	NTCIP 1203 Clause 2.5.1.1.1.8	The DMS supports the full range of these objects with step sizes no larger than 0.5 seconds
defaultPageOffTime	NTCIP 1203 Clause 2.5.1.1.1.9	The DMS supports the full range of these objects with step sizes no larger than 0.5 seconds
defaultCharacterSet	NTCIP 1203 Clause 2.5.1.1.1.10	The DMS supports the following character sets: eightBit

- h. Default Message Control** as defined in NTCIP 1203
- i. Pixel Service Control** as defined in NTCIP 1203
- j. MULTI Error Control** as defined in NTCIP 1203
- k. Illumination / Brightness Control**

As defined in NTCIP 1203. The following list indicates the modified object requirements for this conformance group.

Table 9: Modified Object Ranges for the Illumination / Brightness Control Conformance Group

Object	Reference	Project Requirement
dmsIllumControl	NTCIP 1203 Clause 2.8.1.1.1.1	The DMS supports the following illumination control modes: photocell timer manual
dmsIllumNumBrightLevels	NTCIP 1203 Clause 2.8.1.1.1.4	At least 16

l. Auxiliary I/O**m. Scheduling**

As defined in NTCIP 1203. The following list indicates the modified object requirements for this conformance group.

Table 10: Modified Object Ranges for the Scheduling Conformance Group

Object	Reference	Project Requirement
NumActionTableEntries	NTCIP 1203 Clause 2.9.1.1.1.1	At least 21

n. Sign Status as defined in NTCIP 1203

o. Status Error as defined in NTCIP 1203

p. Pixel Error Status as defined in NTCIP 1203

q. Fan Error Status as defined in NTCIP 1203

r. Power Status as defined in NTCIP 1203

s. Temperature Status as defined in NTCIP 1203

Install necessary hardware for the support of items q, r and s above.

Table 11: Some Optional Object Requirements

Object	Reference	Project Requirement
DefaultFlashOn	NTCIP 1203 Clause 2.5.1.1.1.3	The DMS supports the full range of these objects with step sizes no larger than 0.5 seconds
DefaultFlashOff	NTCIP 1203 Clause 2.5.1.1.1.4	The DMS supports the full range of these objects with step sizes no larger than 0.5 seconds
DmsMultiOtherErrorDescription	NTCIP 1203 Clause 2.7.1.1.1.20	If the vendor implements any vendor-specific MULTI tags, the DMS shall provide meaningful error messages within this object whenever one of these tags generates an error.

5. Documentation

Supply software with full documentation, including a CD-ROM containing ASCII versions of the following Management Information Base (MIB) files in Abstract Syntax Notation 1 (ASN.1) format:

- The relevant version of each official standard MIB Module referenced by the device functionality.
- If the device does not support the full range of any given object within a Standard MIB Module, a manufacturer specific version of the official Standard MIB Module with the supported range indicated in ASN.1 format in the SYNTAX and / or DESCRIPTION fields of the associated OBJECT TYPE macro. Name this file identical to the standard MIB Module, except that it will have the extension ".man".
- A MIB Module in ASN.1 format containing any and all manufacturer-specific objects supported by the device with accurate and meaningful DESCRIPTION fields and supported ranges indicated in the SYNTAX field of the OBJECT-TYPE macros.
- A MIB containing any other objects supported by the device.

Allow the use of any and all of this documentation by any party authorized by the Department for systems integration purposes at any time initially or in the future, regardless of what parties are involved in the systems integration effort.

(C) NTCIP ACCEPTANCE TESTING

Test the NTCIP requirements outlined above by a third party testing firm. Submit to the Engineer for approval a portfolio of the selected firm. Include the name, address, and a history of the selected firm in performing NTCIP testing along with references. Also provide a contact person's name and phone number. Submit detailed NTCIP testing plans and procedures, including a list of hardware and software, to the Engineer for review and approval 10 days in advance of a scheduled testing date. Develop test documents based on the NTCIP requirements of these Project Special Provisions. The acceptance test shall use the NTCIP Exerciser, and / or other authorized testing tools and shall follow the guidelines established in the ENTERPRISE Test Procedures. Conduct the test in North Carolina on the installed system in the presence of the Engineer. Document and certify the results of the test by the firm conducting the test and submit to the Engineer for review and approval. In case of failures, remedy the problem and have the firm retest in North Carolina. Continue process until all failures are resolved. The Department reserves the right to enhance these tests as deemed appropriate to ensure device compliance.

DMS TESTING REQUIREMENTS

(1-2-18)

DB 08-04

(A) GENERAL TEST PROCEDURE

Test the DMS system in a series of design approval and functional tests. The results of each test must meet the specified requirements. These tests shall not damage the equipment. The Engineer will reject equipment that fails to fulfill the requirements of any test. Resubmit rejected equipment after correcting non-conformities and re-testing; completely document all diagnoses and corrective actions. Modify all equipment furnished under this contract, without additional cost to the North Carolina Department of Transportation, to incorporate all design changes necessary to pass the required tests.

Provide four copies of all test procedures and requirements to the Engineer for review and approval at least 30 days prior to the testing start date.

Only use approved procedures for the tests. Include the following in the test procedures:

- A step-by-step outline of the test sequence, showing a test of every function of the equipment or system tested
- A description of the expected nominal operation, output, and test results, and the pass / fail criteria
- An estimate of the test duration and a proposed test schedule
- A data form to record all data and quantitative results obtained during the test.
- A description of any special equipment, setup, manpower, or conditions required by the test

Provide all necessary test equipment and technical support. Use test equipment calibrated to National Institute of Standards and Technology (NIST) standards. Provide calibration documentation upon request.

Conform to these testing requirements and the requirements of these specifications. The Engineer will reject all equipment not tested according to these requirements. It shall be the Design-Build Team's responsibility to ensure the DMS system functions properly even after the Engineer accepts the DMS test results.

Provide 4 copies of the quantitative test results and data forms containing all data taken, highlighting any non-conforming results and remedies taken, to the Engineer for approval. An authorized representative of the manufacturer must sign the test results and data forms.

(B) DESIGN APPROVAL TESTS

Design Approval Tests are applicable to DMS systems not currently on the QPL.

The Design Approval Tests consists of all tests described in Section 2.2 "DMS Equipment Tests" of NEMA TS 4-2005 (Hardware Standards for Dynamic Message Signs with NTCIP Requirements). Perform all tests and submit certified results for review and approval.

PROTOTYPE – Manufacture a prototype Dynamic Message Sign and controller of the type and size described in the project special provisions. In the Engineer's presence, test the prototype according to the Design Approval and Operational Tests. When all corrections and changes (if any) have been made, the Department may accept the prototype DMS and controller as the physical and functional standard for the system furnished under this contract. The Design-Build Team may use the prototype units on this project if, after inspection and rework (if necessary), they meet all physical and functional specifications. In the case of standard product line equipment, if the Design-Build Team can provide test results certified by an independent testing facility as evidence of prior completion of successful design approval tests, then the Engineer may choose to waive these tests.

In each Design Approval Test, successfully perform the Functional Tests described below. Apply the extreme conditions to all associated equipment unless stated otherwise in these Project Special Provisions (PSP).

(C) OPERATIONAL FIELD TEST (ON-SITE-COMMISSIONING)

Conduct an Operational Field Test of the DMS system installed on the project to exercise the normal operational functions of the equipment. The Operational Field Test shall consist of the following tests as a minimum:

1. Physical Examination

Examine each piece of equipment to verify that the materials, design, construction, markings, and workmanship comply with the mechanical, dimensional, and assembly requirements of these Project Special Provisions.

Perform the following tests as a minimum:

- Verify that all surfaces are free of dents, scratches, weld burns, or abrasions. Round sharp edges and corners.

- Verify bend radius of cables is not excessive or could potentially cause damage.
- Verify all modules, lamps, and components are properly secured.
- Verify that there are no exposed live terminals.

2. Continuity Tests

Check the wiring to assure it conforms to the requirements of the appropriate paragraphs of this Special Provision.

3. Functional Tests

Perform the following functional tests:

- Start-up and operate the DMS locally using a laptop computer.
- Use automatic (photo-electric sensor controlled), DMS Control Software to switch between “dim”, “normal”, and “bright” light levels.
- Operation of the DMS with all display elements flashing continuously for 10 minutes at the maximum flash rate.
- Exercise the DMS by displaying static messages, flashing messages, and alternating static and flashing message sequences.
- Automatically poll the DMS by the Control Software at various intervals and verify the data received by Control Software from DMS.
- Download and edit messages using Control Software.
- Execute status request on the DMS controller.
- Observe normal operations during uploading and downloading.
- Input and select messages from the sign controller’s local user interface.
- Test sequence activation at chosen intervals.
- Display and verify all stored messages.
- Verify resumption of standard operation upon interruption of electrical power.
- Demonstrate detected failures and response functions.
- Demonstrate proper operation of the Failure Log.
- Set controller clock using the Control Software.
- Execute system shutdown using the Control Software and local user interface.
- Verify detection of a power failure in the DMS enclosure and the report feature of the failure to the Control Software.

Approval of Operational Field Test results does not relieve the Design-Build Team to conform to the requirements in these Project Special Provisions. If the DMS system does not pass these tests, document a correction or substitute a new unit as approved by the Engineer. Re-test the system until it passes all requirements.

DMS ASSEMBLIES

(1-2-18)

DB 08-04

(A) DESCRIPTION

This section includes all design, fabrication, furnishing, and erection of the DMS structures, platforms, walkways, and ladders for access to the DMS inspection doors, and attachment of the DMS enclosures to the structures in accordance with the requirements of these Project Special Provisions and the project plans developed by the Design-Build Team. Fabricate the supporting DMS assemblies from tubular steel. Furnish pedestal type or overhead type DMS assemblies as shown in the project plans developed by the Design-Build Team and as approved by the Engineer.

Cantilevered and Monotube (horizontal truss) DMS structures will not be allowed.

Provide pedestal DMS structures with a minimum of 25 feet clearance from the high point of the road to the bottom of the DMS enclosure.

Provide full-span overhead DMS structures with a minimum of 20 feet clearance from the high point of the road to the bottom of the DMS enclosure.

Design the DMS assemblies (including footings), DMS mounting assemblies, maintenance platforms, and access ladders and submit shop drawings to the Engineer for approval. A Professional Engineer that is registered in the state of North Carolina will prepare such computations and drawings. These must bear his/her signature, seal, and date of acceptance.

The provisions of Section 900 of the 2018 *Standard Specifications for Roads and Structures* apply to all work covered by this section.

The Design-Build Team shall furnish DMS S-dimension drawings for each proposed DMS to the Engineer for approval.

(B) MATERIAL

Use materials that meet the following requirements of the 2018 *Standard Specifications for Roads and Structures*:

Structural Steel	Section 1072
Overhead Structures	Section 1096
Signing Materials	Section 1092
Organic-Zinc Repair Paint	Article 1080-9
Reinforcing Steel	Sub-article 1070
Direct Tension Indicators	Sections 440 and 1072

(C) CONSTRUCTION METHODS**1. General**

Fabricate the new DMS assemblies, maintenance platforms, attachment hardware, and access ladders in accordance with the details shown in the approved shop drawings

prepared by the Design-Build Team and the requirements of these Project Special Provisions.

No welding, cutting, or drilling in any manner will be permitted in the field, unless approved by the Engineer.

Drill bolt holes and slots to finished size. Holes may also be punched to finished size, provided the diameter of the punched holes is at least twice the thickness of the metal being punched. Flame cutting of bolt holes and slots will not be permitted.

Erect the DMS in accordance with the requirements indicated on the plans developed by the Design-Build Team and in these Project Special Provisions. Field drill two holes per connection in the Z bars for attaching the DMS to the structure. Use two bolts at each connection. Provide two (2) U-bolts at each U-bolt connections such as 1) each truss chord to sign hanger, or 2) each truss chord to platform support. Provide two (2) U-bolts at each U-bolt connection where ends of truss chords are supported. Minimum diameter of all U-bolts shall be $\frac{1}{2}$ inch.

Use two coats of a zinc-rich paint to touch up minor scars on all galvanized materials (Refer to Section 1076-6 of the *2018 Standard Specifications for Roads and Structures*).

For high strength bolted connections, provide direct tension indicator washers.

2. Shop Drawing

Submit to the Engineer for approval a complete design for the DMS assemblies (including footings), maintenance platforms, access ladders, DMS assembly hardware, brackets for supporting the DMS and maintenance platforms. Base the design on the line drawings and correct wind speed in accordance with the latest edition of the *AASHTO LRFD Specifications for Structural Supports for Highway Signs, Luminaires and Traffic Signals*, 1st Edition, and the latest Interim Specifications.

The manufacturer of the DMS assembly must ensure that design of the assembly is compatible with the DMSs for mounting and attachment.

Submit six copies of completely detailed shop drawings and one copy of the design computations for the DMS assembly to the Engineer for approval prior to fabrication. Show in the shop drawings complete design and fabrication details including foundations, provisions for attaching the DMS, maintenance platform and access ladders to supporting structures, applicable material specifications, and any other information necessary for procuring and replacing any part of the complete DMS assembly.

Allow a minimum of 15 working days for shop drawing approval after the Engineer receives them. If revised drawings are necessary, allow an additional 15 working days for review and approval of final shop drawings.

Approval of shop drawings by the Engineer shall not relieve the Design-Build Team of their responsibility for the correctness of drawings, or for the fit of all shop and field connections and anchors.

3. Design and Fabrication

For additional design and fabrication requirements, see Section 906 of the *2018 Standard Specifications for Roads and Structures*.

Dynamic Message Sign Assemblies

Fabricate the supporting structures using tubular members of either aluminum or steel, using only one type of material throughout the project.

Horizontal components of the supporting structures for overhead DMS shall be of a truss design to support the DMS. Truss centerline shall coincide with the centerline of the DMS design area shown on the structure line drawing developed by the Design-Build Team. Provide permanent camber in addition to dead load camber in accordance with the AASHTO *LRFD Specifications for Structural Supports for Highway Signs, Luminaires and Traffic Signals*, 1st Edition, and the latest Interim Specifications. Indicate on the shop drawings the amount of camber provided and the method employed in the fabrication of the support to obtain the camber.

For all U-bolt connections of hanger beams to overhead assembly truss chords, provide U-bolts with a flat washer, a lock washer and double nuts at each end of the U-bolts. All double nuts that are on any U-bolt shall be the same thickness and weight. When assembled, the double nuts shall be brought tight against each other by the use of two wrenches.

Fabricate the attachment assembly for mounting DMS in a manner that will ensure easy removal the DMS.

DMS Maintenance Platform (Walkway)

Provide a maintenance platform, a minimum of three feet wide with open skid-resistant surface and safety railing on the DMS assemblies for access to the DMS inspection door. Provide platforms with fixed safety railings along both sides from the beginning of the platform to the inspection door.

Ensure the design, fabrication and installation of the access platforms on new DMS structures complies with the following:

- The top of the platform grading surface is vertically aligned with the bottom of the DMS door. Ensure the platform extends from the DMS enclosure to the access ladder.
- The DMS door will open 90-degrees from its closed position without any obstruction from the platform or safety handrails.
- The platform is rigidly and directly connected to the walkway brackets and there is no uneven surface between sections.

- Install a 4" x 4" safety angle parallel to and along both sides of the platform and extend it the entire length of the platform. Design the safety angle to withstand loading equivalent to the platform.
- Ensure the platform design allows full access to the DMS enclosure inspection door with no interference or obstructions.

DMS Access Ladder

Provide a fixed ladder, of the same material as the DMS structures, leading to and ending at the access platform. Equip the ladder with a security cover (ladder guard) and lock to prohibit access by unauthorized persons. Furnish locks to operate with a Corbin #2 key and furnish two keys per lock. Design the rungs on 12-inch center to center typical spacing. The first ladder rung shall be no more than 18 inches above the landing pad. Attach the security cover approximately 6 feet above the concrete landing. Design the ladder and security cover as a permanent part of the DMS assembly and include complete design details in the DMS assembly shop drawings. Fabricate the ladder and cover to meet all OSHA requirements and applicable state and local codes, including but not limited to providing a ladder cage.

Furnish and install a level concrete pad a minimum of 4 inches deep, 24 inches wide, and 36 inches long to serve as a landing pad for accessing the ladder. Design the landing pad to be directly below the bottom rung. Access to the ladder shall not be obstructed by the DMS foundation. Provide pre-formed or cast-in place concrete pads.

OVERHEAD AND DYNAMIC MESSAGE SIGN FOUNDATIONS

(9-11-17)

DB9 R07

Description

Sign foundations include foundations for overhead and dynamic message signs (DMS) supported by metal poles or upright trusses. Sign foundations consist of footings with pedestals or drilled piers with or without grade beams or wings, conduit and anchor rod assemblies. Construct sign foundations in accordance with the contract and accepted submittals. Define "cantilever sign" as an overhead cantilever sign support in accordance with Figure 1-1 of the *2013 AASHTO Standard Specifications for Structural Supports for Highway Signs, Luminaires and Traffic Signals*, 6th Edition, and the latest Interim Specifications.

Materials

Use sign foundation materials that meet the *Foundations and Anchor Rod Assemblies for Metal Poles* Project Special Provision found elsewhere in this RFP.

Subsurface Conditions

Assume the following soil parameters and groundwater elevation for sign foundations unless these subsurface conditions are not applicable to sign locations:

- (A) Unit weight (γ) = 120 pcf,
- (B) Friction angle (ϕ) = 30°,
- (C) Cohesion (c) = 0 psf and
- (D) Groundwater 7 feet below finished grade.

A subsurface investigation shall be required if the Engineer determines these assumed subsurface conditions do not apply to a sign location and the sign cannot be moved. Subsurface conditions requiring a subsurface investigation shall include, but are not limited to, weathered or hard rock, boulders, very soft or loose soil, muck or shallow groundwater. No extension of completion date or time will be allowed for subsurface investigations.

Subsurface Investigations

Use a prequalified geotechnical consultant to perform one standard penetration test (SPT) boring in accordance with ASTM D1586 at each sign location requiring a subsurface investigation. Rough grade sign locations to within two feet of finished grade before beginning drilling. Drill borings to two drilled pier diameters below anticipated pier tip elevations or refusal, whichever is higher.

Use the computer software gINT version V8i or later manufactured by Bentley Systems, Inc. with the current NCDOT gINT library and data template to produce SPT boring logs. Provide boring logs sealed by a geologist or engineer licensed in the state of North Carolina.

Sign Foundation Designs

Design sign foundations for the wind zone and clearances shown in the plans developed by the Design-Build Team and the slope of finished grade at each sign location. Use the assumed soil parameters and groundwater elevation above for sign foundation designs unless a subsurface investigation is performed or required by the Engineer. For sign locations requiring a subsurface investigation, design sign foundations for the subsurface conditions at each sign location. Design footings, pedestals, drilled piers, grade beams and wings in accordance with the AASHTO *LRFD Specifications for Structural Supports for Highway Signs, Luminaires and Traffic Signals*, 1st Edition, and the latest Interim Specifications. In some instances, conflicts with drainage structures may dictate sign foundation types.

Design footings in accordance with Section 4.4 of the *AASHTO Standard Specifications for Highway Bridges*. Do not use an allowable bearing pressure of more than 3,000 psf for footings.

Design drilled piers for side resistance only in accordance with Section 4.6 of the *AASHTO Standard Specifications for Highway Bridges* except reduce ultimate side resistance by 25% for uplift. Use the computer software LPILE version 2016 or later manufactured by Ensoft, Inc. to analyze drilled piers. Provide drilled pier designs with a horizontal deflection of less than 1" at top of piers. For cantilever signs with single drilled pier foundations supporting metal poles, use wings to resist torsion forces. Provide drilled pier designs with a factor of safety of at least 2.0 for torsion.

For drilled pier sign foundations supporting upright trusses, use dual drilled piers connected with a grade beam having a moment of inertia approximately equal to that of either pier. The Broms' method is acceptable to analyze drilled piers with grade beams instead of LPILE. Use a safety factor of at least 3.5 for the Broms' design method in accordance with C13.6.1.1 of the 2013 *AASHTO Standard Specifications for Structural Supports for Highway Signs, Luminaires and Traffic Signals*, 6th Edition, and the latest Interim Specifications.

Submit boring logs, if any, working drawings and design calculations for acceptance in accordance with Article 105-2 of the 2018 *NCDOT Standard Specifications for Roads and Structures*. Submit working drawings showing plan views, required foundation dimensions and elevations and typical sections with reinforcement, conduit and anchor rod assembly details. Include all boring logs, design calculations and LPILE output for sign foundation design submittals. Have sign foundations designed, detailed and sealed by an engineer licensed in the state of North Carolina.

Construction Methods

Construct footings, pedestals, drilled piers, grade beams and wings and install anchor rod assemblies for sign foundations in accordance with the *Foundations and Anchor Rod Assemblies for Metal Poles* Project Special Provision found elsewhere in this RFP. Submit boring logs, if any, working drawings and design calculations for acceptance in accordance with Article 105-2 of the 2018 *NCDOT Standard Specifications for Roads and Structures*. Submit working drawings showing plan views, required foundation dimensions and elevations and typical sections with reinforcement, conduit and anchor rod assembly details. Include all boring logs, design calculations and LPILE output for sign foundation design submittals. Have sign foundations designed, detailed and sealed by an engineer licensed in the state of North Carolina.

CCTV CAMERA EQUIPMENT INFRASTRUCTURE

(5-24-18)

(A) DESCRIPTION

Furnish and install CCTV camera field equipment cabinets and related equipment as described in this Section.

MVD equipment may be co-located with CCTV camera locations as shown in the *Complete 540 ITS and AET Concept Plan* dated May 24, 2018.

Provide a system to protect field devices and electronic equipment from lightning and surge protection using UL-listed surge protection devices.

(B) MATERIAL

1. CCTV Camera Assemblies

CCTV camera assemblies will be procured by the Toll System Integrator.

2. CCTV Camera Cabinet

Provide Type 336A CCTV camera cabinets that meet the following minimum requirements:

- Accommodate an Ethernet edge switch (supplied by NCDOT),
- Termination of the Ethernet cable to the camera,
- Fiber-optic interconnect center,

- Grounding bus bar,
- 19-inch rack system for mounting of all devices in the cabinet,
- Pull-out shelf for laptop and maintenance use,
- Stationary shelf for shelf-mounting Ethernet edge switch,
- Fluorescent lighting,
- Ventilation fan,
- Thermostats,
- 120 VAC power supply,
- 120 VAC GFCI-protected duplex outlets for tools,
- 120 VAC surge protected duplex outlets for equipment,
 - Surge protection on incoming and outgoing electrical lines (power and data),
- Transformers/power supplies, and
- Power strip along vertical rail.

Provide cabinets complete with a prefabricated cabinet shell, and all internal components and equipment, back and side panels, front and back doors, terminal strips, cabling and harnesses, surge protection for power and communication circuits, power distribution blocks or assemblies, shelves, connectors and all mounting hardware necessary for installation of equipment.

Provide the cabinets using unpainted sheet aluminum with a minimum thickness of 0.125 inch.

Provide pole-mounted versions of the 336A CCTV camera cabinet as shown in the *NCTA ITS Standard Details*. Provide a concrete maintenance pad with new CCTV camera cabinets. The maintenance pad shall measure 36" x 78", as shown in the *NCTA ITS Standard Details*.

Provide the rack assembly with a removable, standard 19-inch EIA compliant rack. Equip each cabinet with an aluminum storage compartment mounted in the rack assembly with the following dimensions (± 0.5 inch): 16 inches wide, 14 inches long and 1.75 inches deep. Provide the compartment with ball-bearing telescoping drawer guides to allow full extension from the rack assembly. The storage compartment shall open to provide a full-depth storage space for cabinet documentation and other miscellaneous items. The storage compartment shall be of adequate construction to support a weight of 20 pounds without sagging when extended. The top of the storage compartment shall be hinged aluminum. Provide at least one removable metal full-depth shelf with each cabinet.

Provide all cabinets and exterior door seams with continuously welded seams and with smooth exterior welds. Provide all cabinets with two (2) full-size doors (one front, one back). Provide the doors with three hinges, or a full-length stainless steel piano hinge, with stainless steel pins spot-welded at the top. The hinges shall utilize stainless steel hinge pins. Mount the hinges so that they cannot be removed from the door or cabinet without first opening the door. Brace the door and hinges to withstand a 100-pound per vertical foot of door height load applied vertically to the outer edge of the door when standing open. There shall be no permanent deformation or impairment of any part of the door or cabinet body when the load is removed. Provide the cabinet door with a #2 Corbin lock. Provide two keys for each cabinet. Provide the cabinet doors so they can be padlocked. Provide door openings with double flanges on all four sides.

Doorstops shall be included at 90° and 180° positions. Provide both the door and the doorstop mechanism of sufficient strength to withstand a simulated wind load of five pounds per square foot of door area applied to the both inside and outside surfaces without failure, permanent deformation,

or compromising of door position and normal operation. Provide the cabinets without auxiliary police doors.

Ensure that cabinet doors include a gasket to provide a dust and weather-resistant seal when closed. Provide the gasket material with closed-cell neoprene and shall maintain its resiliency after exposure to the outdoor environment. The gasket shall show no sign of rolling or sagging, and shall ensure a uniform dust and weather-resistant seal around the entire door facing.

Ventilation

Provide a cooling fan in all cabinets with a minimum capacity of 100 CFM. Provide a thermostat to control the ventilation system.

Provide the cabinets with vent openings in the door to allow convection cooling of electronic components. Locate the vent opening on the lower portion of the cabinet door and cover fully on the inside with a commercially available disposable three-layer graded type filter.

Provide cabinets with a serial number unique to the manufacturer. Engrave the entire identification code on a metallic plate that is epoxied to the cabinet on the upper right-hand sidewall.

Electrical

Provide a power distribution assembly that consists of power filters, transient voltage suppression, equipment grounding, main and branch circuit breakers for equipment, electrical outlets, lighting and ventilation.

Provide AC isolation within the cabinet. Configure all cabinets to accept 120 VAC from the utility company.

Provide UL listed circuit breakers with an interrupt capacity of 5,000 amperes and insulation resistance of 100 M Ω at 500 VDC. Provide power distributions blocks for use as power feed and junction points for two and three wire circuits. The line side of each shall be capable of handling up to 2/0 AWG conductors. Isolate the AC neutral and equipment ground wiring and terminal blocks from the line wiring by an insulation resistance of at least 10 M Ω when measured at the AC neutral.

For components that are furnished by the Design-Build Team that are mounted on cabinet side panels, fasten with hex-head or Phillips-head machine screws. Install the screws into tapped and threaded holes in the panels. The components include, but are not limited to, terminal blocks, bus bars, and DC power supply chassis.

Tag and identify all cabinet wiring installed by the Design-Build Team using insulated pre-printed sleeves. The wire markers shall identify in plain words with sufficient details without abbreviations or codes.

Neatly arrange all wiring in the cabinet, firmly lace or bundle, and mechanically secure the wiring without the use of adhesive fasteners. Route and secure all wiring and cabling to avoid sharp edges and to avoid conflicts with other equipment or cabling. Terminate all wiring on a terminal block, strip, bus bar, device clamp, lug, or connector; do not splice any wiring. Label all wiring, cables, terminal strips, and distribution blocks provided by the Design-Build Team. Provide strain relief for all cabling.

Cable Terminations

Terminate all field cabling on the respective surge protection devices for 4-wire EIA 568 data communications, and 24 VAC power cable.

Surge Suppression

Provide surge protection both ahead of and behind the ITS device electronics for the cameras. All surge protection devices shall have an ambient operating temperature of -40 degrees F to 165 degrees F with 95 percent non-condensing relative humidity. All surge protection devices shall comply with the following standards:

- UL 1449 version 3 for electrical power, and
- UL 497B for paired data communications.

Provide surge protection for all four pairs of the Ethernet cable. Data voltage shall be 48 VDC. Surge protector will function with a Maximum Continuous Operating Voltage (MCOV) of 64VDC, and will clamp (on 1000VDC, 1mA, 10/1000 μ s waveform) at 72VDC +/- 5V. The maximum continuous current on data lines under normal conditions will be 1.5 A. The peak surge current that can be passed on any pair of data lines can be no more than 30A. Response time on data lines shall be no more than 1 pico-seconds.

Line Side CCTV Camera Power

Each cabinet must be provided with a hybrid-type, power line surge protection device mounted inside the power distribution assembly. The protector must be installed between the applied line voltage and earth ground. The surge protector must be capable of reducing the effect of lightning transient voltages applied to the AC line. The protector must be mounted inside the power distribution assembly housing facing the rear of the cabinet. The protector must include the following features and functions:

- Maximum AC line voltage: 140 VAC,
- Twenty pulses of peak current, each of which must rise in 8 microseconds and fall in 20 microseconds to ½ the peak: 20,000 Amperes,
- The protector must be provided with the following terminals:
 - Main line (AC line first stage terminal),
 - Main neutral (AC neutral input terminal),
 - Equipment line out (AC line second state output terminal, 19 amps),
 - Equipment neutral out (neutral terminal to protected equipment),
 - Ground (earth connection),
- The main AC line in and the equipment line out terminals must be separated by a 200 Microhenry (minimum) inductor rated to handle the 10 Amp AC service,
- The first stage clamp must be between main line and ground terminals,
- The second stage clamp must be between equipment line out and equipment neutral,
- The protector for the first and second stage clamp must have an MOV or similar solid-state device rated at 20 KA and must be of a completely solid-state design (i.e., no gas discharge tubes allowed),

- The main neutral and equipment neutral out must be connected internally and must have an MOV similar solid-state device or gas discharge tube rated at 20 KA between main neutral and ground terminals,
- Peak clamp voltage: 350 volts at 20 KA (voltage measured between equipment line out and equipment neutral out terminals. Current applied between main line and ground terminals with ground and main neutral terminals externally tied together),
- Voltage must never exceed 350 volts,
- The protector must be epoxy-encapsulated in a flame-retardant material,
- Continuous service current: 10 Amps at 120 VAC RMS, and
- The equipment line out must provide power to cabinet CCTV camera and communications equipment and to the 24V power supply.

Load Side CCTV Camera Power

Load side protection is designed to restrict surge current transients from entering the power source from the CCTV camera device and/or site. The surge protection for the CCTV camera power source shall have an operating voltage of 120 volts single phase and a maximum continuous operating voltage of 150 volts single phase.

The device's surge protection shall be rated at a minimum of 90,000 amps per phase and have maximum clamping voltage ratings of 330 volts at 500 amps, 395 volts at 3,000 amps, and 533 volts at 10,000 amps. The surge protection shall also be UL listed for a minimum suppressed voltage of 330 volts per line to the neutral/ground. The suppression device shall be of the metal oxide varistor (MOV) type.

Load Side CCTV Camera Data

Provide specialized surge protection devices at the supply and load sides of all low voltage connections to the CCTV camera device and its operating subsystems. Provide specialized surge protection devices at the supply and load sides of all low voltage Ethernet data connections between the CCTV camera and the CCTV camera cabinet. These connections include, but are not limited to, Ethernet data cables that comply with EIA requirements as detailed in the EIA-568 standard.

The surge protection shall have an operating voltage to match the characteristics of the CCTV camera, such as 24 volts of direct current (VDC) or 24 volts of alternating current and less than 5 VDC for data. These specialized surge protection units shall be UL listed according to the UL 497B (paired-data cable) standards. The minimum surge current rating for the surge protection shall be 2,000 amps for data and telecommunications and 2,000 amps for twisted pair video.

Grounding

Provide a cabinet grounding system for the CCTV camera cabinets as shown in the *NCTA ITS Standard Details*. Incorporate a means to bond (i.e., connect) all metal components of the camera and cabinets to the grounding system with a grounding cable that uses a mechanical connection on the equipment side and an exothermic welded connection at the down cable.

Provide a minimum of four grounding electrodes with a minimum length of 10 feet each and listed per UL requirements as detailed in the UL 467J standard. Provide copper clad or solid copper electrodes.

(C) CONSTRUCTION METHODS

1. General

Locate and mark proposed cabinet locations in the field. Do not construct any conduits or junction boxes to proposed devices until the device locations are approved by NCTA.

2. Electrical and Mechanical Requirements

Ground all equipment as called for in the *Standard Specifications*, these Project Special Provisions, and the *NCTA ITS Standard Details*.

Furnish all tools, equipment, materials, supplies, and hardware necessary to support a fully operational CCTV camera system as depicted in the *NCTA ITS Standard Details*.

3. CCTV Camera Assemblies

CCTV camera assemblies will be installed and tested by the Toll System Integrator.

4. CCTV Camera Cabinet

Mount the CCTV camera cabinet on the pole supporting the CCTV camera it controls using approved hardware and attachment brackets. Mount the cabinet 4 feet from the ground to the center of the cabinet. Furnish and install a cabinet mounting adapter bracket as necessary to ensure all metal pole hand holes are accessible. Have NCTA approve the proposed mounting position prior to attaching the CCTV camera cabinet to the pole.

Ground all cabinets in accordance with the requirements of these Project Special Provisions. Keep the ground wire from the cabinet ground bus bar to the ground rod assembly or array as short as possible. Ensure the ground wire is not in contact with any other part of the cabinet.

Tag and identify all cabinet wiring installed by the Design-Build Team using insulated pre-printed sleeves. The wire markers shall identify in plain words with sufficient details without abbreviations or codes.

Neatly arrange all wiring, firmly lace or bundle, and mechanically secure the wiring without the use of adhesive fasteners. Route and secure all wiring and cabling to avoid sharp edges and to avoid conflicts with other equipment or cabling. Terminate all wiring on a terminal block, strip, bus bar, device clamp, lug, or connector, do not splice any wiring. Label all wiring, cables, terminal strips, and distribution blocks installed by the Design-Build Team. Provide strain relief for all cabling.

Fasten all components installed by the Design-Build Team to be mounted on cabinet side panels with hex-head or Phillips-head machine screws. Install the screws into tapped and threaded holes in the panels. The components include, but are not limited to, terminal blocks; bus bars, and DC power supply chassis.

Terminal strips shall be provided with the cabinets to support Ethernet communications and the 24 VAC power as will be required for power and data.

5. Power Service

Provide 120 VAC power as shown on the *NCTA ITS Standard Details*. Comply with the *Electrical Service* section of these Project Special Provisions.

6. Grounding

Ground the CCTV camera pole and subsystems in accordance with the special details in the *NCTA ITS Standard Details*.

Device Line Side

Connect the surge protection devices on the CCTV camera power source on the line side. This device shall provide protection between line-to-neutral, line-to-ground, line-to-line and neutral-to-ground.

Device Load Side

Connect the surge protection devices in the power line side ahead of all CCTV camera electronic equipment. This installation technique is designed to restrict earth current transients induced within the ground or directly from the power source from entering the ITS device through the incoming 120/240-volt power circuit. This device shall provide protection between line-to-neutral, line-to-ground, line-to-line and neutral to ground.

Device Data

Connect the specialized surge protection devices at the supply and line sides of all Ethernet connections to the CCTV camera device and its operating subsystems.

7. GPS Coordinates

Provide real world coordinates for all junction boxes and equipment cabinets installed or utilized under this project as described in Section 1716-3 of the *Standard Specifications*.

MICROWAVE VEHICLE DETECTION INFRASTRUCTURE

(5-24-18)

Furnish and install MVD field equipment cabinets and related equipment as described in this Section.

MVD equipment may be co-located with CCTV camera locations as shown in the *Complete 540 ITS and AET Concept Plan* dated May 24, 2018.

Provide a system to protect field devices and electronic equipment from lightning and surge protection using UL listed surge protection devices.

(A) MATERIALS

1. MVD Sensors

MVD sensors will be procured by the Toll System Integrator.

2. MVD Cabinet

Furnish MVD cabinets to terminate the field wiring, house the surge protection devices and electrical breakers, power supplies, fiber-optic cable termination and Ethernet edge switch as listed below:

Device	Master MVD Type 336 Cabinet	Slave NEMA 4 MVD Cabinet
Backplane	X	X
120V Electrical Breakers	X	
Power Supplies	X	
120 Surge Suppression	X	
24 Surge Suppression	X	2X
Fiber-Optic Patch Panel	X	
Ethernet Edge Switch*	X	

** Supplied by NCDOT

** Requires one for communications from master cabinet and one to detector

Provide a concrete maintenance pad with new MVD cabinets. The maintenance pad shall measure 36" x 78", as shown in the *NCTA ITS Standard Details*.

Master MVD Type 336 Cabinet

Provide a new pole-mounted cabinet (Type 336-size, minimum) with a prewired backplane with DIN rails to mount the above described devices described below. Provide cabinet assemblies that comply with NEMS TS-2 1998 and UL 508 standards. The backplane shall be securely bolted to the cabinet wall or 19" rack or other rigid mounting.

Provide 120V AC surge protection, breakers and power supply(s). Surge protection shall be three-stage with surge arresting diodes and gas discharge tubes.

Slave MVD NEMA 4X Cabinet

Provide Type 5052 H-32 aluminum NEMA 4X cabinet. Slave cabinets may be used when the MVD unit does not (or will not) contain a 120 VAC power service drop and fiber-optic drop cable. Provide continuously welded seams. Include weldnuts for mounting the backplane. Provide full length stainless steel hinges. Furnish seamless polyurethane door gaskets. Provide cabinets with either a hinged padlock or No. 2 door lock. Coordinate with the TSI to determine the cabinet size. Minimum size shall be 10"x 8"x 6" or larger as needed to house the required devices. Provide mounting brackets for mounting on MVD poles. Provide doors that open 180 degrees.

Furnish a grounding lug and cable grips to secure cables. Provide a cabinet with a prewired backplane. Provide knockouts suitable for providing water tight connections.

Backplane

Furnish a backplane with two DIN rails to mount the above described devices. Furnish DIN-rail mounted terminal blocks for terminating device, field wiring.

All DIN-rail mounted devices shall operate at either 120V AC or 24V DC. Devices shall have pluggable screw terminal mounted on a DIN rail.

Ambient operating temperature is -40 degrees to 185 degrees F.

(B) CONSTRUCTION METHODS**1. MVD Sensors**

MVD sensors will be installed and tested by the Toll System Integrator.

2. MVD Cabinet

Install a new MVD pole-mounted master and slave cabinets and install the backplane. Install the DIN-rail mounted surge protection, power supply, breakers and other communications devices. Terminate the field and communications wiring on the terminal blocks. Terminate the fiber-optic drop cable in a master Type 336 cabinet patch panel. For NEMA 4X MVD slave cabinets, the cable connection to the master cabinet will be provided by the Toll System Integrator.

3. GPS Coordinates

Provide real world coordinates for all junction boxes and equipment cabinets installed or utilized under this project as described in Section 1716-3 of the *Standard Specifications*.

COMMUNICATIONS HARDWARE

(5-24-18)

(A) GENERAL

This section details the requirements for communication hardware to support traffic data collection, traffic management devices, wrong way detection, etc. Ethernet switches will be provided by NCDOT.

Furnish and install one open, non-lockable, 19-inch communications with no side panels in each AET vault. Install the racks in locations as directed by the Engineer. Provide enough rack space to house the fibers designated for each location plus 50% spare space.

(B) MATERIALS**1. Hub Cabinet**

Standards: Ensure that the hub cabinet complies with the following standards:

- ANSI;
- ASTM;
- IMSA;
- ISO 9001;
- NEC;
- NEMA TS-2; and
- UL listed.

Functional: Furnish a Caltrans Type 333 hub cabinet meeting the following minimum requirements:

Side-by-side, double doors on both front and rear of cabinet

- Fiber-optic splice centers
- Grounding bus bar

- 19-inch rack system for mounting of all devices in the cabinet
- Pull-out shelf for laptop and maintenance use
- Maintenance access connections
- Fluorescent lighting
- Ventilation fans
- 120VAC power supply
- 120VAC ground fault circuit interrupter (GFCI)-protected duplex outlets for tools
- 120VAC surge-protected duplex outlets for equipment
- Sunshields
- Lightning and surge protection on incoming and outgoing electrical lines (power and data)
- Power strip along vertical rail
- Air conditioner for cooling Ethernet hub switch
- UPS with sufficient capacity to hold hub's electrical load for 4 hours

Physical Features: Provide cabinets that are completely weatherproof to prevent the entry of water. Provide cabinet and door exterior seams that are continuously welded and all exterior welds are smooth. Provide cabinets with two full-size doors with three hinges, or a full-length stainless-steel piano hinge, with stainless steel pins spot-welded at the top. Provide hinges that utilize stainless steel hinge pins. Provide hinges that are mounted so that they cannot be removed from the door or cabinet without first opening the door. Provide door and hinges braced to withstand a 100-pound per vertical foot of door height load applied vertically to the outer edge of the door when standing open. Ensure that there is no permanent deformation or impairment of any part of the door or cabinet body when the load is removed. Provide cabinet door fitted with a #2 Corbin lock. Provide two keys for each cabinet. Provide cabinet doors that are also pad lockable. Provide door openings that are double flanged on all four sides.

Provide cabinets constructed of unpainted sheet aluminum alloy H5052-H32 with a minimum thickness of 0.125 inch.

Provide the hub cabinet with sunshields outside to deflect solar heat away from the cabinet. The sunshields must be offset a minimum of one inch from the exterior cabinet walls. Ensure that the sunshields are fabricated from 5052-H32 aluminum sheet that is 0.125-inch thick, and that sunshield corners are rounded and smoothed for safety. Mount the sunshields on standoffs at the top and each side of the cabinet.

Provide doorstops at 90 and 180-degree positions. Ensure that both the door and the doorstop mechanism are of sufficient strength to withstand a simulated wind load of five pounds per square foot of door area applied to the both inside and outside surfaces without failure, permanent deformation, or compromising of door position and normal operation. Do not provide auxiliary police doors.

Ensure that cabinet doors include a gasket to provide a dust and weather-resistant seal when closed. Ensure that the gasket material is closed-cell neoprene and maintains its resiliency after exposure to the outdoor environment. Ensure that the gasket shows no sign of rolling or sagging, and provide a uniform dust and weather-resistant seal around the entire door facing.

Provide cabinets that include predrilled holes of standard diameter and bolt pattern with four (4) anchor bolts with each cabinet unit as part of the unit price bid. Provide a panel with each cabinet that matches the rest of the cabinet; and is held in place by four bolts provided with the panel. Drill or punch the panel to accommodate the bolts; the drill holes shall match the bolt pattern of the base cabinet of the cabinet. Provide a panel designed to be fitted in the interior of the cabinet and fabricated of the same material and thickness as the cabinet bottom.

Provide rails to create a cage to mount hardware, wiring panels and miscellaneous mounting brackets. Provide rails constructed of .1345-inch steel or .105-inch stainless steel. Provide rails with a keyhole design with slots 2 inches on center with a top opening of 5/8 inch in diameter to allow the insertion of a .625-inch by 1-inch carriage bolt. Ensure that the rails are 1.5 to 2 inches wide by .5 inches deep. Drill and tap the rails for 10-32 screws or rack screws with EIA universal spacing.

Provide rack assemblies that have a removable, standard 19-inch EIA compliant rack. The rack shall have a clearance between the rails of 17.5 inches.

Equip each cabinet with an aluminum storage compartment mounted in the rack assembly with the following dimensions (± 0.5 inch): 16 inches wide, 14 inches long, and 1.75 inches deep. Provide compartment with ball-bearing telescoping drawer guides to allow full extension from the rack assembly. Ensure that when extended, the storage compartment opens to provide storage space for cabinet documentation and other miscellaneous items. Ensure that the storage compartment is of adequate construction to support a weight of 20 pounds when extended without sagging. Provide a top to the storage compartment that is hinged aluminum. Provide two (2) removable metal shelves with each cabinet.

Furnish a cabinet base extender with each hub cabinet that complies with the requirements of the "Equipment Cabinet Base Extender" section of these Project Special Provisions.

Lighting: Provide the field cabinet with two 20-watt fluorescent lamps and clear shatterproof shield assemblies which are mounted on the inside front and rear top of the cabinet. Ensure that these lamps are unobstructed and able to cast light on the equipment. Equip the field cabinet with door-actuated switches so that the lamps automatically turn on when either cabinet door is opened and go off when the doors are closed.

Electrical: Provide a service panel assembly to function as the entry point for AC power to the cabinet and the location for power filtering, transient suppression, and equipment grounding. Provide AC isolation within the cabinet. Configure cabinet to accept 120 VAC from the utility company.

Provide circuit breakers that are UL listed and have an interrupt capacity of 5,000 amperes and insulation resistance of 100 M Ω at 500 VDC. Provide power distribution blocks that are suitable for use as power feed and as junction points for two and three wire circuits. Ensure that the line side of each block is capable of handling up to 2/0 AWG conductors. Ensure that the AC neutral and equipment ground wiring and terminal blocks are isolated from the line wiring by an insulation resistance of at least 10 M Ω when measured at the AC neutral.

Provide UL listed surge protection devices according to the UL 1449, 2nd edition standard that comply with the NEMA requirements as detailed in the NEMA LS 1 (1992) standard.

Provide branch circuits, surge protection devices, and grounding for the ITS device-connected load served by the cabinet, including ventilation fans, internal lights, electrical receptacles, etc., as shown on the plans developed by the Design-Build Team. Terminate field wiring on terminal blocks with the voltage and current rating of the terminal block is greater than the voltage and current rating of the wire fastened to it.

Furnish a power distribution assembly that fits in the EIA 19-inch rack and provides for protection and distribution of 120VAC power.

Ensure that ground bus bars are fabricated from a copper alloy material compatible with copper wire. Use ground bus bars that have at least two positions where a #6 AWG stranded copper wire can be attached.

Mount the ground bus bar on the side of the cabinet wall adjacent to the service panel assembly for the connection of AC neutral wires and chassis ground wires. If more than one ground bus bar is used in a cabinet, use a minimum of a #10 AWG copper wire to interconnect them.

Wire into the cabinet's circuitry the connector harnesses for the ITS devices and other accessory equipment to be housed therein.

Terminate conductors on terminal blocks using insulated terminal lugs large enough to accommodate the conductor to be terminated. When two or more conductors are terminated on field wiring terminal block screws, use a terminal ring lug for termination of those conductors. Number all terminal block circuits and cover the blocks with a clear insulating material to prevent inadvertent contact.

Ventilation: Ensure the cabinet assembly can maintain the temperature and humidity within the environmental requirements of the hub switches.

Include two cooling fans with 100 CFM, minimum capacity. Provide thermostats to be incorporated into the ventilation system. Mount fans in the top of the cabinet.

Provide the cabinets with vent openings in the lower portion of the door to allow convection cooling of electronic components. Cover them fully on the inside with a commercially available disposable three-layer graded type filter. All air entering the cabinet must pass through the air filter.

Air Conditioner: Furnish each hub cabinet with a rack mounted air-cooled air conditioner that operates on 120VAC. The air conditioner shall fit within a 19-inch EIA communications rack and shall not be external mounted on the cabinet. The air conditioner shall be mounted in the bottom of the cabinet to avoid damage to any communications equipment.

The air conditioners shall have a built-in condensate evaporator and condensate drain fitting and hose to the outside of the cabinet. The hose shall extend to the base of the cabinet. The air conditioner shall be rated for a minimum of 3500 BTU. There shall be low temperature control to prevent overcooling.

Provide EMI/RFI transient spike protection. Equip the cabinet and air conditioner with remote monitoring of high temperature and low airflow conditions. Intake air shall enter through cabinet door vent and be exhausted through top cabinet vents. Air conditioners shall be CFC free R134a refrigerant and shall use closed loop cooling. Insulate all cold components (coolant lines, compressor, evaporator, etc.) with high-performance insulation.

Blower motors shall be UL listed. Ensure the blower motors are equipped with automatic reset thermal overload protection. Provide double sealed and double shielded ball bearings.

The air conditioners shall have permanent corrugated aluminum or stainless-steel air filters. The filters shall be removable and washable.

All grilles shall be stainless steel.

Environmental Requirements: Ensure the cabinet assembly can maintain the temperature and humidity within the environmental requirements of the Layer 3 Ethernet hub switch

1. Ethernet Switches

Layer 3 Hub Switches and Ethernet edge switches will be provided by NCDOT.

2. Communication Rack

Provide all communications rack meeting these minimum performance requirements:

- All equipment shall comply with ANSI/EIA RS-310D,
- Provide frame and external components with zinc coating per ASTM B633,
- Paint interior and exterior components per RAL 7035,
- Provide UL 508 and NEMA Type 12 certifications, and

Provide all communications racks meeting the following minimum material requirements:

- 19-inch EIA single-bay
- Nominal height of 78 inches less base
- Nominal 4-inch high ventilated base
- Depth: 31 inches
- House 44 units of rack space
- All-metal components

Vented top with three integral prewired fans, and fans that provide up to 300 cubic feet per minute (cfm) of exhaust.

Furnish and install one metal shelf kit per each rack. Provide each shelf the full width and depth of the rack angles and attach directly to the rack angles. Furnish and install one metal keyboard slide out drawer per each rack.

Mechanical: Construct all rack frames from 12-gauge, cold-formed steel. Construct the vented base from 16-gauge steel. Construct the 19-inch electrical rack angles from 12-gauge steel.

Finish: Furnish factory-applied paint on the exterior of all components with a color that matches that of the respective room they are located. Submit color samples to the Authority for review and approval.

(C) CONSTRUCTION

1. Hub Cabinet

General: Ensure all cabinet wiring is tagged and identified by the use of insulated pre-printed sleeves and follows the project's cable identification scheme. Ensure that the wire markers identify usage in plain words with sufficient details without abbreviations or codes.

Use stranded copper for all conductors, including those in jacketed cables. Neatly arrange all wiring, firmly lace or bundle it, and mechanically secure the wiring without the use of adhesive fasteners. Route and secure all wiring and cabling to avoid sharp edges and to avoid conflicts with other equipment or cabling. Terminate all wiring on a terminal block, strip, bus bar, device clamp, lug, or connector. Do not splice any wiring. Label all wiring, cables, terminal strips, and distribution blocks with permanent and waterproof tags. Provide strain relief for all cabling with connectors, all cabling entering knockouts or ports at the equipment, and where appropriate.

Fasten all components of the cabinet assembly to be mounted on cabinet side panels with hex-head or Phillips-head machine screws. Install the screws into tapped and threaded holes in the panels. The components include, but are not limited to, terminal blocks; bus bars, panel and socket mounted TVSS, circuit breakers, accessory and equipment outlets, and DC power supply chassis. Configure each cabinet mounted UPS unit for remote monitoring from the MRTMC for the hub cabinets.

Fasten all other cabinet components with hex-head or Phillips-head machine screws installed with nuts (with locking washer or insert) or into tapped and threaded holes. Fasten stud-mounted components to a mounting bracket providing complete access to the studs and mounting nuts. Ensure that all fastener heads and nuts (when used) are fully accessible within a complete cabinet assembly, and any component is removable without requiring removal of other components, panels or mounting rails. Do not use self-tapping or self-threading fasteners.

Furnish and install a 48" 120 VAC power strip vertically along one of the rear rails of the communications rack. Provide a power strip that has at least eight outlets along its length.

Provide a cabinet that is ISO 9001 certified at the time of bid letting.

Equip the cabinet with lightning and surge protection described separately in these Project Special Provisions.

Install base mounted cabinets as shown on the plans developed by the Design-Build Team and as approved by the Engineer. Install the required number of conduits as shown on the plans developed by the Design-Build Team plus two additional spare stubbed out conduits. Position the ends of conduits approximately 2 inches above the finished surface of the concrete base.

Mount the hub cabinet on a cabinet base extender in accordance with the "Equipment Cabinet Base Extender" section of these Project Special Provisions.

Mount surge protection devices in the cabinet for the particular field devices that will be connected to that cabinet.

Terminate power service wire, and data cabling on the appropriate terminal strips, surge protection devices or jacks in the cabinet with insulated terminal lugs or connectors. Use a calibrated ratchet-type crimping tool to install the insulated terminal lugs onto the field wires.

Terminate the fiber-optic cable in the hub splice centers in the cabinet as described in these Project Special Provisions.

Label spare circuits of the data cables and connect them to the cabinet ground bus bar.

Neatly bundle and identify all field wiring cables in the cabinet with permanent waterproof tags.

Ground the hub cabinet in accordance with the requirements of these Project Special Provisions. Keep the ground wire from the cabinet ground bus bar to the ground rod assembly or array as short as possible. Ensure the ground wire is not in contact with any other part of the cabinet.

1. UPS

Install a UPS unit in the new hub cabinet. Connect the UPS unit to a power outlet. Connect the UPS monitoring port to the Layer 3 Ethernet hub switch.

Install the UPS monitoring software on the ITS LAN workstations in the MRTMC to remotely monitor the UPS. Run the UPS diagnostics. Configure the remote monitoring to send email alerts.

Plug the power cord of the Layer 3 Ethernet hub switch into the UPS.

2. Ethernet Switches

Ensure that all communications hardware is UL listed.

Verify that network/field/data patch cords meet all ANSI/EIA/TIA requirements for Category 5e four-pair unshielded twisted pair cabling with stranded conductors and RJ-45 connectors.

Receive approval for the System Configuration Report before submitting product submittal data, purchasing, installing, and configuring the communications hardware.

Ensure that all project IP addresses and VLAN IDs are assigned as defined in the System Configuration Report. Ensure that at a minimum, the switch configuration includes the following features: SNMP, STP, Port Security, all required VLANs. Ensure unused switch ports are disabled. Ensure the as-built documentation includes the identification of all IP addresses and VLANs, and associated hardware devices and device locations. Configure the Ethernet network so the existing CCTV cameras and DMS will be in separate VLANs.

Ensure that the Regional ITS Engineer will be able to manage each Ethernet switch individually or as a group/cluster for switch configuration, performance monitoring, and troubleshooting. Note that these specifications require additional minimum management intelligence (i.e., Layer 2+) typical of most current industrial Ethernet deployments. Ensure that the edge switch includes Layer 2+ capability providing architecture standardization, open connectivity (i.e., interoperability), bandwidth management, rate limiting, security filtering, and general integration management of an advanced Ethernet switching architecture.

Mount the Ethernet switches inside each field cabinet or communications rack using manufacturer-recommended or Engineer-approved attachment methods, attachment hardware, and fasteners. Ensure that the edge switch is mounted securely in the cabinet and is fully accessible by field technicians without blocking access to other equipment. Verify that fiber-optic jumpers consist of a length of cable that is connectorized on both ends, primarily used for interconnecting termination or patching facilities and/or equipment. Use fiber-optic jumpers that are factory assembled and connectorized and are certified by the fiber-optic jumpers' manufacturer to meet the relevant performance standards required below. Verify that network/field/data jumper cables meet all

ANSI/EIA/TIA requirements for Category 5e 4-pair unshielded twisted pair cabling with stranded conductors and RJ-45 connectors.

4. Network Management Software

Utilize the existing MRTMC network management software (NMS) server application to manage all devices. Configure the software applications to monitor and manage the Layer 3 Ethernet routing and edge switches, and other Ethernet devices in this project. Establish/modify user access rights and monitoring rights. Expand the respective databases through an automatic utility within the NMS or manually enter the data. Establish groupings of devices with like functions or features, this would include geographically related, device types, owners. Setup automatic database and configuration backups, setup system and device alarms and alarm notifications.

Setup and modify the respective existing graphical network views. Use mapping images provided by manufacturers to locate devices geographically.

5. Communication Rack

Electrical: Furnish and install an outlet strip and 10-foot power cord along one rear vertical rack frame. Furnish and install strips that use 120 VAC 60 Hz power and shall contain at least 10 outlets over the 70 inches. Furnish and install grounding bus bar system for the ground rack mounted electrical equipment. Equip door with grounding studs.

Furnish and install cable management hardware for attachment vertically along the rack frame and horizontally between 19-inch rack angles. Cable management hardware shall run vertically up one rear rack frame and shall include six horizontal runs per rack. Provide hardware including cable organizers and clamps to provide strain relief and cable mounting.

Keyboard Shelf: Install keyboard shelf at a height comfortable for operator use when sitting on a stool. Provide tamper-resistant but removable screws through hinges and exterior panels. Furnish any special tools required to remove tamper resistant screws.

Ground the racks to a building ground.

ELECTRICAL SERVICE

(5-24-18)

(A) MATERIALS

Comply with the National Electrical Code (NEC), the National Electrical Safety Code (NESC), the *Standard Specifications*, the Project Special Provisions, and all local ordinances.

Provide UL-listed 2-inch Schedule 80 conduit for underground runs. If electrical conduit shares a trench with fiber-optic conduit, use conduit color other than black, orange, blue or white.

Obtain the maximum available ground fault current from the utility company. Print this information on a durable label and adhere to the dead front of the disconnect.

Provide all materials necessary to form a complete electrical service assembly as shown in 2018 *Roadway Standard Drawing* No. 1700.01, "Electrical Service Options".

Provide an external electrical service disconnect at each new ITS device cabinet location. Furnish external electrical service disconnects with circuit breakers designed as per the

NEC in a lockable NEMA 3R enclosure. Ensure service disconnects are listed as meeting UL Standard UL-489 and marked as being suitable for use as service equipment. Fabricate enclosure from galvanized steel and electrostatically apply dry powder paint finish, light gray in color, to yield a minimum thickness of 2.4 mils. Provide ground bus and neutral bus with a minimum of four terminals with minimum wire capacity range of number 14 AWG through number 4 AWG.

Furnish NEMA Type 3R meter base rated 200A minimum for underground service that meets the requirements of the local utility. Provide meter base with sockets' ampere rating based on sockets being wired with a minimum of 167 degrees F insulated wire. With each meter base, provide a blank meter socket cover made from UV stabilized polycarbonate or metal and that is either clear or gray in color to prevent access to interior of meter base until meter is installed by the local power company. Furnish four terminal, 600 volt, single phase, 3-wire meter bases that comply with the following:

- Line, load, and neutral terminals accept 4/0 AWG and smaller Copper / Aluminum wire
- With or without horn bypass
- Made of galvanized steel
- Listed as meeting UL-414
- Underground service entrance as shown on the plans developed by the Design-Build Team.

Ensure meter bases have electrostatically applied dry powder paint finish, light gray in color, with minimum thickness of 2.4 mils. Furnish 1" watertight hub for threaded rigid conduit with meter base. For all new ground-mounted electrical service assemblies for underground electrical service, provide a combination panel with pedestal extension. Ensure combination meter and disconnect mounted in a pedestal for underground service is listed as meeting UL Standard UL-231. Do not provide wood posts, steel U-channel posts, square tube sign posts, metal framing, or any method other than an underground service pedestal to mount meter bases and disconnects for new underground electrical service.

At the main service disconnect, furnish, and install UL-approved lightning arresters that meet the following requirements:

Type of Design	Silicon Oxide Varistor
Voltage	120/240 Single phase, 3 wire
Maximum current	100,000 amps
Maximum energy	3000 joules per pole
Maximum number of surges	Unlimited
Response time one milliamp test	5 nanoseconds
Response time to clamp 10,000 amps	10 nanoseconds
Response time to clamp 50,000 amps	25 nanoseconds

Leak current at double the rated voltage	None
Ground wire	Separate

As indicated below, provide the following:

CCTV Camera, MVD Master Cabinet, Hub Cabinet:

- 1 single-pole 15A breaker
- 3 spare slots/spaces for a total of four (4) breaker slots/spaces
- 3-wire stranded #12 AWG copper feeder conductors with THWN rating

DMS Cabinet:

- 1 double-pole 50A breaker
- 2 slots / spaces for a total of four (4) breaker slots/spaces
- 4-wire stranded #8 AWG copper feeder conductors with THWN rating

Furnish 2” rigid galvanized conduit between disconnect and the equipment cabinets as required. For underground runs greater than 10 feet in length, the Design-Build Team may transition from rigid galvanized conduit to PVC conduit for the remainder of the underground run beyond the initial 10 feet. Furnish Schedule 40 PVC female adapters to connect the PVC conduit to the threaded end of the rigid galvanized conduit. The interior surface of one end of the PVC female adapter shall be compatibly threaded to connect it to the threaded end of the rigid metallic riser without the aid of additional fittings, hardware, or adhesives. The opposite end of the adapter shall be non-threaded to permit a slip fit, glued connection to the underground PVC conduit.

Provide a grounding electrode system at all new electrical services. Provide marker tape for underground installation, above ground grounding electrodes and buried ground wire. Provide all grounding electrodes and ground wire necessary to ensure that grounding system, whether existing or new, complies with all grounding requirements of these Project Special Provisions.

1. 10KVA Single Phase General Purpose Transformer

Should a transformer be needed for a standalone DMS more than 900 ft. from a power source, furnish a double-wound, dry type general purpose transformer to isolate the line side voltages from the load side voltages as shown in the plans developed by the Design-Build Team. Provide the transformer with the following specifications:

- Primary Volts: 120/240 with 83/41 Amps Max. 60Hz.
- Secondary Volts: 120/240 with 83/41 Amps Max. 60Hz.
- 10kVA power rating.
- Electrostatic shielding between primary and secondary windings.
- Epoxy-silica encapsulated core and coil.

- Copper windings and copper lead wire terminations.
- Multiple front and bottom knockout for conduit entry/exit.
- Ground studs for conduit bonding.

Provide the transformer in a lockable NEMA 3R enclosure suitable for mounting on a metal pole.

2. Equipment Cabinet Disconnect

Provide new equipment cabinet disconnects. Furnish panels that have a minimum of four (4) spaces in the disconnect. Furnish circuit breakers with a minimum of 10,000 RMS symmetrical amperes short circuit current rating in a lockable NEMA 3R enclosure. Ensure equipment cabinet disconnects are listed as meeting UL-67 and marked as being suitable for use as service equipment. Ensure circuit breakers are listed as meeting UL-489. Fabricate enclosure from galvanized steel and electrostatically apply dry powder paint finish, light gray in color, to yield a minimum thickness of 2.4 mils. All exterior surfaces must be powder coated steel. Provide ground bus and neutral bus with a minimum of four terminals and a minimum wire capacity range of number 14 through number 3/0 AWG.

3. 4-Wire Copper Feeder Conductors

Furnish 4-wire stranded copper feeder conductors with THWN rating for supplying power to DMS field equipment cabinets. Provide conductors with black, red, white, and green insulation that are intended for power circuits at 600 Volts or less and comply with the following:

- Listed as meeting UL-83
- Meets ASTM B-3 and B-8 or B-787 standards.

4. 3-Wire Copper Feeder Conductors

Furnish 3-wire stranded copper feeder conductors with THWN rating for supplying power to CCTV camera, MVD master, and hub cabinets. Provide conductors with black, white, and green insulation that are intended for power circuits at 600 Volts or less and comply with the following:

- Listed as meeting UL-83
- Meets ASTM B-3 and B-8 or B-787 standards.

5. Grounding System

Furnish 5/8"x10' copper clad steel grounding electrodes (ground rods), #4 AWG solid bare copper conductors, and irreversible compression ground connectors for grounding system installations. Comply with the NEC, *Standard Specifications*, and these Project Special Provisions.

(B) CONSTRUCTION METHODS**1. General**

All work involving electrical service shall be coordinated with the appropriate electric utility company. Coordinate with the utility company to ascertain the feasibility of installing electrical service at each location before performing any work. Coordinate with the local power company concerning the location of the electric power service relative to the equipment cabinet. Obtain all required local permits before beginning work.

Run feeder conductors separately from all other conductors in a 2-inch rigid galvanized conduit. Do not allow feeder conductors to share conduits with any other conductors or cables. Do not route unfused electrical feeder conductors inside of metal poles. Permanently label conductors at all access points using nylon tags labeled with permanent ink. Ensure each conductor has a unique identifier. Label conductors immediately upon installation. Use component name and labeling scheme approved by the Engineer.

Use rigid galvanized conduit for all underground conduit runs 10 feet or less in length. For underground runs greater than 10 feet in length, the Design-Build Team may transition from rigid galvanized conduit to PVC conduit for the remainder of the run beyond the initial 10 feet using an approved PVC female adapter. Apply thread seal tape to the threads of the rigid galvanized conduit before screwing the PVC adapter onto the threaded male end of the conduit. Connect the threaded female end of the PVC adapter to the threaded end of the rigid galvanized conduit, then connect the not threaded end of the adapter to the PVC conduit using a slip fit, glued connection.

Upon completion of electrical service installation and backfilling of all excavations, restore the disturbed ground to its original condition as determined and approved by the Engineer. For paved areas, replace removed or damaged pavement with in kind materials, matching the elevation, color, texture/finish, and general appearance of the surrounding pavement. For unpaved areas, backfill excavations with removed material, tamp the backfilled material and rake smooth the top 1½ inches. Finish unpaved areas flush with surrounding natural ground and to match the original contour of the ground. Seed with same type of grass as surrounding area and mulch the newly seeded area. If unpaved area was not grassed, replace the original ground cover in kind as directed by the Engineer.

Provide all necessary stainless-steel banding hardware and clamps for securely attaching service disconnects, combination panels and service conduits and risers to metal poles.

2. New Electrical Service for ITS Devices

Install new electrical service for a device cabinet in accordance with the *NCTA ITS Standard Details*. Install a new electrical service comprised of an external service disconnect and a meter base housed in a combination panel. If more than one cabinet is fed from the same utility company service point, a common meter may be utilized with individual breakers at the meter service and disconnects at each

device cabinet. The cost of running electrical service to all cabinets will include any transformers required.

Locate all secondary power service points outside the controlled access right of way. Locate combination panels as shown on the *NCTA ITS Standard Details* dated ~~February 1~~ May 24, 2018. After installation of the meter base, the local power company will install a new meter and make any necessary connections to the power lines.

Have the power company route the service drop underground to the service entrance equipment, even where source power lines are overhead; wood poles on NCTA right-of-way for power service are generally not permissible with the exception of bringing power just inside the right-of-way.

Place durable vinyl identification number sticker (with 2" letters) on meter base. Utilize stickers that match the appearance of those used elsewhere on NCTA projects. Submit proposed sticker to NCTA for approval.

Where the feeder conductors are routed to the equipment cabinet through underground conduit, use 2-inch short risers to extend underground conduit vertically into the bottom of pole-mounted equipment cabinets. Attach the short riser to the pole. Do not install "freestanding" short risers that are offset from the pole and run straight up from the ground into the cabinet bottom. Connect the 2-inch short risers to the bottom of the pole-mounted cabinet using standard conduit outlet bodies between the top of short riser attached to the pole and the bottom of the cabinet.

3. 10KVA Single Phase General Purpose Transformer

As shown on the plans developed by the Design-Build Team, install a single-phase general-purpose transformer in a NEMA 3R enclosure. Route the conductors from the transformer secondary to the DMS equipment cabinet or equipment cabinet disconnect in rigid galvanized conduit. Bond the equipment cabinet disconnect in accordance with the NEC. Provide all mounting hardware and other parts and labor necessary to install the transformer on a wood pole or on a 6"x6" treated wood post.

4. Equipment Cabinet Disconnect

Install equipment cabinet disconnects and circuit breakers. Install THWN stranded copper feeder conductors, as shown in the plans developed by the Design-Build Team, between the general-purpose transformer and the equipment cabinet disconnect. Route the conductors from the equipment cabinet disconnect to the equipment cabinet in rigid galvanized steel conduit. Bond the equipment cabinet disconnect in accordance with the NEC. Ensure that the grounding system complies with the grounding requirements of these Project Special Provisions, the *Standard Specifications*, *Roadway Standard Drawings*, and the *NCTA ITS Standard Details*.

5. 4-Wire Copper Feeder Conductors

At locations shown in the plans developed by the Design-Build Team, install 4-wire THWN stranded copper feeder conductors to supply 240/120 VAC to the DMS field equipment cabinets. Size the conductors as specified in the plans developed by the Design-Build Team. Comply with the *Standard Specifications* and *Roadway Standard Drawings* and all applicable electrical codes.

6. 3-Wire Copper Feeder Conductors

At locations shown in the plans developed by the Design-Build Team, install 3-wire THWN stranded copper feeder conductors to supply 240/120 VAC to the CCTV camera, MVD master, and hub cabinets. Size the conductors as specified in the plans developed by the Design-Build Team. Comply with the *Standard Specifications* and *Roadway Standard Drawings* and all applicable electrical codes.

7. Grounding System

In addition to NEC requirements, test grounding electrode resistance for a maximum of 20 ohms. Install additional ground rods to grounding electrode system as necessary to meet test requirements. Furnish 5/8" x 10' copper clad steel grounding electrode system (ground rods), #4 AWG solid bare copper conductors, and irreversible compression ground connectors for grounding system installations. Comply with NEC, the *Standard Specifications*, these Project Special Provisions, and the *NCTA ITS Standard Details* dated ~~February 1~~ May 24, 2018.

Where a grounding electrode system is connected to the electrical service in accordance with the NEC, test grounding electrode resistance for a maximum of 20 ohms. Grounding electrode resistance test must be verified or witnessed by the Engineer or the Engineer's designated representative. Furnish and install additional ground rods to grounding electrode system as necessary to meet the requirements of these Project Special Provisions and test requirements.

Follow test equipment's procedures for measuring grounding electrode resistance. When using clamp-type ground resistance meters, readings of less than 1 ohm typically indicate a ground loop. Rework bonding and grounding circuits as necessary to remove ground loop circuits and retest. If a ground loop cannot be identified and removed to allow the proper use of a clamp-type ground resistance meter, use the three-point test method.

Submit a completed Inductive Loop & Grounding Test Form available on the Department's website. The form is located on the Department's website at:

<https://connect.ncdot.gov/resources/safety/Pages/ITS-and-Signals.aspx>

Install a length of marker tape 6 to 12 inches below finished grade directly over grounding electrodes and conductors.

CCTV CAMERA AND MVD METAL POLES

(5-24-18)

(A) DESCRIPTION

Furnish and install metal poles for CCTV cameras and MVDs, drilled pier foundations, grounding systems, and all necessary hardware, including lowering devices. Design, furnish, and install drilled pier foundations for CCTV and MVD metal poles with all necessary hardware. The work covered by this special provision includes requirements for the design, fabrication, and installation of custom designed CCTV and MVD metal poles.

For design of drilled pier foundations for metal poles, conform with Section 12.4 of the *Signals and Intelligent Transportation Systems Project Special Provisions*, version 12.6

(B) MATERIALS

Comply with applicable sections of the *2018 Standard Specifications for Roads & Structures*, hereinafter referred to as the *Standard Specifications*. Provide designs of completed assemblies with hardware that equals or exceeds *AASHTO Standard Specifications for Structural Supports for Highway Signs, Luminaires and Traffic Signals* 6th Edition, 2013 and 2015 Interim Revisions (hereafter called AASHTO), including the latest interim specifications. Provide assemblies with a round or near-round (18 sides or more) cross-section, or a multi-sided cross section with no less than six sides. The sides may be straight, convex, or concave.

Provide CCTV camera metal poles that are 50 feet (minimum) as called for in the Plans. Provide metal MVD poles at a minimum of 20 feet.

Ensure that metal poles permit cables to be installed inside poles. For holes in the poles used to accommodate cables, provide full-circumference grommets.

After fabrication, hot-dip galvanized steel poles, and all parts used in the assembly in accordance with Section 1076 of the *Standard Specifications*. Design structural assemblies with weep holes large enough and properly located to drain molten zinc during galvanization process. Galvanize structures to meet or exceed AASHTO M 111. Provide galvanizing on hardware that meets or exceeds ASTM Standard A-153. Ensure that threaded material is brushed and re-tapped as necessary after galvanizing. Perform repair of damaged galvanizing that complies with the following:

Repair of Galvanizing Article 1076-6

Standard Drawings for Metal Poles are available that supplement these project special provisions. These drawings are located on the Department's website:

<https://connect.ncdot.gov/resources/safety/Pages/ITS-Design-Resources.aspx>

Comply with article 1098-1B "General Requirements" of the *Standard Specifications* for submittal requirements. Furnish shop drawings for approval. Provide the copies of detailed shop drawings for each type of structure as summarized below. Ensure that shop drawings include material specifications for each component and identify welds by type and size on the drawing details, not in table format. Do not release structures for fabrication until shop drawings have been approved by NCDOT. Provide an itemized bill of materials for all structural components and associated connecting hardware on the drawings.

Comply with Subarticle 1098-1(A) “General Requirements” of the *Standard Specifications for Qualified Products List (QPL)* submittals. All shop drawings must include project location description, device inventory number(s), and a project number or work order number on the drawings.

Summary of Information Required for Metal Pole Review Submittal:

Item	Hardcopy Submittal	Electronic Submittal	Comments / Special Instructions
Sealed, Approved ITS Plan/Loading Diagram	1	1	All structure design information needs to reflect the latest approved ITS plans
Custom Pole Shop Drawings	4 sets	1 set	Submit drawings on 11” x 17” format media Show NCDOT inventory number(s), contractor’s name and relevant revision number in the title block. in or above the title block. All drawings must have a <u>unique drawing</u> number for each project and identified for multiple pages.
Structure Calculations	1 set	1 set	Not required for Standard QPL Poles
Custom Foundation Drawings	4 sets	1 set	Submit drawings on 11” x 17” format media. If QPL Poles are used, include the corresponding QPL pole shop drawings with this submittal. All drawings must have a <u>unique drawing</u> number for each project and identified for multiple pages.
Foundation Calculations	1	1	Submit copies of LPILE input, output and pile tip deflection graph paper the “Non-Standard Foundation Design” subarticle of this section of these Project Special Provisions for each foundation.
Soil Boring Logs and Report	1	1	Report should include a location plan and a soil classification report including soil capacity, water level, hammer efficiency, soil bearing pressure, soil density, etc. for each pole.

NOTE – All shop drawings and custom foundation design drawings must be sealed by a professional Engineer licensed in the state of North Carolina. All geotechnical information must be sealed by either a Professional Engineer or geologist licensed in the state of North Carolina. Include a title block and revision block on the shop drawings and foundation designs showing the NCDOT inventory number.

Shop drawings and foundation drawings may be submitted together or separately for approval. However, shop drawings must be approved before foundations can be reviewed. Foundation designs will be returned without review if the associated shop drawing has not been approved. Incomplete submittals will be returned without review. The Reviewer has the right to request additional analysis and copies of the calculations to expedite the approval process.

Fabricate CCTV and MVD metal poles from coil or plate steel to meet the requirements of ASTM A595 Grade A tubes. For structural steel shapes, plates and bars use A572 Gr 50 min or ASTM A709 Gr 50 min. Provide poles that are round in cross section or multisided tubular shapes and have a uniform linear taper of 0.14 in/ft. Construct shafts from one piece of single ply plate or coil so there are no circumferential weld splices. Galvanize in accordance with AASHTO M111 and/or ASTM A123 or an approved equivalent.

Ensure that allowable pole deflection does not exceed that allowed per 5th Edition AASHTO. Ensure that maximum deflection at the top of the pole does not exceed 2.0 percent of the pole height.

Use the submerged arc process or other NCDOT previously approved process suitable for poles to continuously weld pole shafts along their entire length. The longitudinal seam weld will be finished flush to the outside contour of the base metal. Ensure shafts have no circumferential welds except at the lower end joining the shaft to the pole base. Provide welding that conforms to Article 1072-20 of the *Standard Specifications*, except that no field welding on any part of the pole will be permitted unless approved by a qualified engineer.

Refer to Metal Pole Standard Drawing Sheets M2 through M5 for fabrication details. Fabricate anchor bases from plate steel meeting, as a minimum, the requirements of ASTM A 36M or cast steel meeting the requirements of ASTM A 27M Grade 485-250, AASHTO M270 Gr 36 or an approved equivalent. Conform to the applicable bolt pattern and orientation as shown on Metal Pole Standard Drawing Sheet M2.

Ensure all hardware is galvanized steel or stainless steel. The Design-Build Firm is responsible for ensuring that the designer/fabricator specifies connecting hardware and/or materials that do not create a dissimilar metal corrosive reaction.

Unless otherwise required by the design, ensure each anchor rod is 2" diameter and 60" length. Provide 10" minimum thread projection at the top of the rod, and 8" minimum at the bottom of the rod. Use anchor rod assembly and drilled pier foundation materials that meet the *Foundations and Anchor Rod Assemblies for Metal Poles* provision.

For each structural bolt and other steel hardware, hot dip galvanizing shall conform to the requirements of AASHTO M 232 (ASTM A 153). Ensure end caps for poles are constructed of cast aluminum conforming to Aluminum Alloy 356.0F.

Provide a circular anchor bolt lock plate that will be secured to the anchor bolts at the embedded end with two washers and two nuts. Provide a base plate template that matches the bolt circle diameter of the anchor bolt lock plate. Construct plates and templates from ¼" minimum thick steel with a minimum width of 4". Galvanizing is not required.

Provide four heavy hex nuts and four flat washers for each anchor bolt. For nuts, use AASHTO M291 grade 2H, DH, or DH3 or equivalent material. For flat washers, use AASHTO M293 or equivalent material.

Provide a 2-inch hole equipped with an associated coupling and weatherhead approximately 5 feet below the top of the pole to accommodate passage of CCTV and MVD cables from inside the pole to the CCTV camera or MVD unit.

Provide a 2-hole equipped with an associated coupling and conduit fittings/bodies approximately 18" above the base of the pole accommodate passage of CCTV and MVD cables from the respective CCTV or MVD cabinet to the inside of the pole. Refer to Metal Pole Standard Drawing Sheet M3 for fabrication details.

Have poles permanently stamped above the base hand hole with the identification tag details as shown on Metal Pole Standard Drawing Sheet M2.

For each pole, provide a 1/2-inch minimum thread diameter, coarse thread stud and nut for grounding which will accommodate #4 AWG ground wire. Ensure that the lug is electrically bonded to the pole and is conveniently located inside the pole at the hand hole.

Provide a removable pole cap with stainless steel attachment screws for the top of each pole.

Ensure that the cap is cast aluminum conforming to Aluminum Association Alloy 356.0F. Furnish cap attached to the pole with a sturdy chain or cable approved by the Engineer. Ensure that the chain or cable is long enough to permit the cap to hang clear of the pole-top opening when the cap is removed.

Furnish poles with 1/2 inch x 36-inch air terminal, with #4 AWG wire, routed down pole and attached to cabinet equipment grounding system.

Furnish MVD poles that when erected in foundation and completely installed provide a mounting height for the MVD at a minimum height as recommended by the MVD manufacturer.

1. Camera Lowering Device

Provide lowering devices on a steel pole as shown in the *NCTA ITS Standard Drawings*. Consider the lowering device and pole as two interdependent components of a single unit, and provide them together to ensure compatibility of the pole and lowering device.

(a) Pole

Use a pole as shown in the *NCTA ITS Standard Drawings*. The lowering mechanism and cabling shall be internal to the pole. Provide the pole with a 1.25" PVC conduit inside to house the composite camera cable. This conduit separates the cable from the winch cable. Use a pole that is equipped with a hand hole of sufficient size to provide access to the pole interior and for temporarily securing and operating the lowering tool. Ensure that the pole-top tenon is rotatable through 360 degrees. Equip the mounting plates with holes and slots to lock the plate and arm to the pole with bolts.

(b) Lowering Device

Use a lowering device as shown in the *NCTA ITS Standard Drawings*. Ensure that the lowering device provides the electrical connections between the control cabinet

and the equipment installed on the lowering device without reducing the function or effectiveness of the equipment installed on the lowering device or degrading the overall system in any way. Ensure that the only cable in motion when operating the lowering device is the stainless-steel lowering cable contained within the pole. Ensure that the lowering device includes a disconnect unit for electrically connecting the equipment installed on the lowering device's equipment connection box to the power, data, and video cables (as applicable); a divided support arm, a pole adapter for the assembly's attachment to the rotatable pole-top tenon, and a pole-top junction box, as shown in the *NCTA ITS Standard Drawings*.

Ensure that all the lowering device's external components are made of corrosion-resistant materials that are powder-coated, galvanized, or otherwise protected from the environment by industry-accepted coatings that withstand exposure to a corrosive environment.

(c) Equipment Connection Box

Provide an equipment connection box for connecting the CCTV camera to the lowering device. Ensure that the equipment connection box is watertight and able to seal the interior from moisture and dust.

The equipment connection box shall be of two-piece clamshell design with one hinge side and one latch side to facilitate easy opening. The equipment connection box shall be cast aluminum with the stabilizing weights on the outside of the box to increase room on the interior. The box shall be capable of having up to 40 pounds of stabilizing weights. The bottom of the equipment connection box shall be drilled and tapped with a 1-1/2" NPT thread to accept industry standard dome housings and modifiable to accept a wide variety of other camera mountings. The junction box shall be gasketed to prevent water intrusion. The bottom of the box shall incorporate a screened and vented hole to allow airflow and reduce internal condensation. Furnish the camera with an epoxy sealed connection flange at the point of connection of the dome to the equipment connection box to ensure that there is no moisture migration from the equipment connection box into the camera housing.

(d) Disconnect Unit

The disconnect unit shall have a load capacity 600 lbs. with a 4 to 1 safety factor. There shall be a locking mechanism between the fixed and moveable components of the lowering device. The movable assembly shall have a minimum of two latches. This latching mechanism shall securely hold the device and its mounted equipment. The latching mechanism shall operate by alternately raising and lowering the assembly using the winch and lowering cable. When latched, all weight shall be removed from the lowering cable. The fixed unit shall have a heavy duty cast tracking guide and means to allow latching in the same position each time. The contact unit housing shall be weatherproof with a gasket provided to seal the interior from dust and moisture.

The prefabricated components of the lift unit support system shall be designed to preclude the lifting cable from contacting the power or video cabling. This adapter shall have an interface to allow the connection of a contractor provided 1.25 inch PVC conduit and be located just below the cable stop block at the back of the lowering device. The D-B Team shall supply internal conduit in the pole. The only cable permitted to move within the pole or lowering device during lowering or raising shall be the stainless steel lowering cable. All other cables must remain stable and secure during lowering and raising operations.

(e) Connector Block

Provide a connector block as shown in the *NCTA ITS Standard Drawings* and directed by the Engineer. Provide modular, self-aligning, and self-adjusting female and male socket contact halves in the connector block. Provide a minimum of fourteen, including two spare contacts, and a maximum of 20 contacts. Provide contact connections between the fixed and movable lowering device components that are capable of passing EIA-232, EIA-422, EIA-485, and Ethernet data signals and 1 volt peak to peak (Vp-p) video signals, as well as 120 VAC, 9-24 VAC, and 9-48 VDC power. Ensure that lowering device connections are capable of carrying the signals, voltages, and current required by the device(s) connected to them under full load conditions.

The current carrying male contacts shall be 1/8 inches outside diameter. The current carrying female contacts shall be 1/8 inches I.D. Provide two male contacts that are longer than the other contacts to mate first and break last, providing optimum grounding performance.

All of the contacts shall be recessed 1/8" from the face of the connector. Cored holes in the rubber measuring 1/4" in diameter and 1/8" deep molded into the connector body are centered on each contact on the face of the connector to create rain-tight seals when mated with the male connector.

The female and male socket contact halves of the connector block shall be constructed of thermosetting synthetic rubber which meets all requirements for UL-94 VO rating. Permanently mold the wire leads from both the male and female contacts in a body of heavy-duty molded synthetic rubber, chlorosulfonated polyethylene, or an approved equal. The female brass socket contacts and the male high conductivity brass pin contacts shall be permanently molded into the synthetic rubber body.

The wire leads from both the male and female contacts shall be permanently and integrally molded in the synthetic rubber body. The current carrying and signal wires molded to the connector body shall be constructed of #18/1 AWG Hypalon jacketed wire.

All electrical and video coaxial connections between the fixed and lowerable portion of the connector block shall be protected from exposure to the weather by a waterproof seal to prevent degradation of the electrical contacts. The electrical

connections between the fixed and movable lowering device components shall be designed to conduct high frequency data bits and one-volt peak-to-peak video signals as well as the power requirements for operation of dome environmental controls.

(f) Lowering Tool

Provide a metal-frame lowering tool with winch assembly and a cable with a combined weight less than 35 pounds, a quick release cable connector, and an adjustable safety clutch. Ensure that the lowering tool can be powered using a half-inch chuck, variable-speed reversible industrial-duty electric drill to match the manufacturer-recommended revolutions per minute, or supply a drill motor for the lowering tool.

Ensure that the lowering tool supports itself and the load. Ensure that the lowering tool is equipped with a positive braking mechanism to secure the cable reel during raising and lowering operations, and to prevent freewheeling.

Use a lowering tool equipped with gearing that reduces the manual effort required to operate the lifting handle to raise and lower a capacity load. Provide the lowering tool with an adapter for operating the lowering device with the portable half-inch chuck drill using a clutch mechanism.

Ensure that the lowering tool is manufactured of durable, corrosion-resistant materials that are powder-coated, galvanized, or otherwise protected from the environment by industry-accepted coatings that withstand exposure to a corrosive environment.

Provide a minimum of one lowering tool plus any additional tools. Upon a project's final acceptance, deliver the lowering tool to NCTA.

(g) Lowering Cable

Provide a lowering cable with a minimum diameter of 0.125 inch. Construct it of stainless steel aircraft cable with a minimum breaking strength of 1,740 pounds, and with seven strands of 19-gauge wire each. Ensure that the prefabricated components for the lift unit support system preclude the lifting cable from contacting the power or video cables.

(h) Wiring

Ensure that all wiring meets NEC requirements and follows the equipment manufacturers' recommendations for each device connected on the pole, at the lowering device, and in the field cabinet.

(A) CONSTRUCTION METHODS**1. CCTV and MVD Metal Pole Foundations**

Construct drilled pier foundations and install anchor rod assemblies in accordance with the *Foundations and Anchor Rod Assemblies for Metal Poles* provision (SP09-R005) located on the Department's *2018 Standard Specifications and Provisions* website:

<https://connect.ncdot.gov/resources/Specifications/Pages/Specifications-and-Special-Provisions.aspx>

2. CCTV and MVD Metal Poles

Erect CCTV and MVD metal poles only after concrete has attained a minimum allowable compressive strength of 3000 psi. Final approval of foundation is contingent upon concrete achieving a compressive strength of 4,500 psi strength as required by *Foundations and Anchor Rod Assemblies for Metal Poles* provision. Connect poles to grounding electrodes and bond them to the electrical service grounding electrodes.

For holes in the poles used to accommodate cables, install grommets before wiring pole or arm. Do not cut or split grommets.

Attach the hand hole covers to the pole by a sturdy chain or cable. Ensure the chain or cable is long enough to permit the cover to hang clear of the opening when the cover is removed, and is strong enough to prevent vandalism. Ensure the chain or cable will not interfere with service to the cables in the pole.

Attach cap to pole with a sturdy chain or cable. Ensure the chain or cable is long enough to permit the cap to hang clear of the opening when the cap is removed.

Perform repair of damaged galvanizing that complies with the *Standard Specifications*, Article 1076-6 "Repair of Galvanizing".

Install galvanized wire mesh around the perimeter of the base plate to cover the gap between the base plate and top of foundation for debris and pest control.

Install a 1/4" thick plate for concrete foundation tag to include: concrete grade, depth, diameter, and reinforcement sizes of the installed foundation.

Install CCTV and MVD metal poles, hardware, and fittings as shown on the manufacturer's installation drawings. Install poles so that when the pole is fully loaded it is within .5 degrees of vertical.

3. Camera Lowering Device

Preassemble all components on the ground and tension the lifting cables. Assemble and install the pole and lowering device according to the manufacturer's recommended procedures.

Make a watertight seal between the lowering device and CCTV dome housing. Test the watertight seal of the lowering device and CCTV dome. Test the seal with a water hose.

Ensure that all other cables remain stable and secure during lowering and raising operations and are not entangled or abraded by movement of the lowering cable.

Ensure that the divided support arm and receiver brackets self-align the contact unit with the pole centerline during installation and that the contact unit cannot twist when subjected to the design wind speeds defined in the Standard Drawings for Metal Poles Drawing M 1. Supply an internal conduit in the pole for the power and video cabling.

Ensure all pulleys installed for the lowering device and portable lowering tool have sealed, self-lubricated bearings, oil-tight bronze bearings, or sintered bronze bushings.

4. Pole Numbering System – New Poles

Attach an identification tag to each pole shaft and mast arm section as shown on Metal Pole Standard Drawing Sheet M2 “Typical Fabrication Details Common To All Metal Poles”.

LIGHTING

1.00 DESCRIPTION

The work covered by this section consists of furnishing, installing, connecting, and placing into satisfactory operating condition roadway lighting at locations shown on the plans (provided by the Design-Build Team). Perform all work in accordance with these Special Provisions, the Plans, the National Electrical Code, and North Carolina Department of Transportation "Standard Specifications for Roads and Structures" (*2018 Standard Specifications*).

Perform all work in conformance with Division 14 of the *2018 Standard Specifications for Roads and Structures* except as modified or added to by these Special Provisions. Install all bore pits outside the clear zone, as defined in the AASHTO Roadside Design Guide or as directed by the Engineer.

In addition to the requirements of Division 1400, other specific Sections of the *2018 Standard Specifications for Roads and Structures* applicable to the work on this project are listed below.

Section 1401	High Mount Standard and Portable Drive Unit
Section 1404	Light Standards
Section 1407	Electric Service Pole and Lateral
Section 1408	Light Control System
Section 1409	Electrical Duct
Section 1410	Feeder Circuits
Section 1411	Electrical Junction Boxes
Section 1412	Underpass Lighting

2.00 LIGHT STANDARD LIGHT EMITTING DIODE (LED) LUMINAIRES

2.10 DESCRIPTION

Furnish, install and place into satisfactory operation an American Electric Lighting (AEL) Autobahn Series ATB2 luminaire with the appropriate delivered lumens and distribution as required to meet the minimum lighting design requirements. The luminaire shall be mounted to the light standard via a tenon adapter with an 8” bracket arm. The Design-Build Team shall also include the wiring inside the light standard from the circuit conductors to the luminaire, in-line breakaway fuseholders and fuses and ground wiring at the single arm and twin arm light standards.

Mounting Height	American Electric Part Number
45’	ATB2-80BLEDE10-480-R3-20-BL-NL-P7-SH

Third party certified photometric files in IES format are required to be submitted with the catalog cuts for the proposed LED roadway luminaire. Photometric files must show that proposed luminaire will meet or exceed the design shown in the plans.

The manufacturer shall state the Light Loss Factor (LLF) used in the photometric calculations for the proposed luminaire. LLF shall be calculated as follows:

$$LLF = \text{Lamp Lumen Depreciation (LLD)} \times \text{Luminaire Dirt Depreciation (LDD)}$$

- Lamp Lumen Depreciation (LLD) shall be the value calculated and reported by the manufacturer based on the LM-80 and TM-21 reports for the proposed fixture for 70,000 hours at 25° C.
- Luminaire Dirt Depreciation (LDD) = 0.90

2.20 MATERIALS

2.21 LUMINAIRE REQUIREMENTS

A. General Requirements

- LM-79 photometric test reports shall be provided for all LED luminaires. LM-79 luminaire photometric reports shall be produced by an independent test laboratory and include the following:
 - Name of test laboratory. The test laboratory must hold National Voluntary Laboratory Accreditation Program (NVLAP) accreditation for the IES LM-79 test procedure or must be qualified, verified, and recognized through the U.S. Department of Energy’s CALiPER program.
 - Report number
 - Date
 - Complete luminaire catalog number. Catalog number tested must match the catalog number of the luminaire submitted, except for variations which do not affect performance.
 - Description of luminaire, LED light source(s), and LED driver(s)
 - Goniophotometry
 - Colorimetry

- LM-80 lumen maintenance test report shall be provided for each respective LED light source.
- Luminaire shall be constructed of a single piece die cast aluminum housing. Each luminaire shall be finished gray in color unless otherwise noted.
- The luminaire shall have a 7 pin ANSI C136.41 compliant photocontrol receptacle for future expansion capabilities.
- Provide a summary of reliability testing performed for LED driver.
- Luminaires maximum total power consumption shall not exceed the values shown in the table above. Nominal luminaire input wattage shall account for nominal applied voltage and any reduction in driver efficiency due to sub-optimal driver loading.
- Luminaire shall have a maximum Backlight, Uplight & Glare (BUG) rating of 3-0-3 and an IESNA distribution of Type II or Type III as required to meet the average maintained footcandle level and the average to minimum uniformity ratio requirements shown in the Scope of Work. The same BUG rating and distribution type shall be used throughout the project.
- Minimum Ingress Protection (IP) dust and moisture ratings for the luminaire electrical components (driver and surge protection) and luminaire optical components shall be IP65 and IP66, respectively, as specified in ANSI C136.25.
- Luminaire shall have external and internal labels per ANSI C136.15 and ANSI C136.22, respectively. Internal label shall identify the manufacturer, year and month of manufacture and the manufacturer's part number.
- Luminaire shall have an internal bubble level.
- Luminaires shall start and operate in -20°C to +40°C ambient.
- Luminaires shall be rated for continuous service at an ambient temperature of 40°C (104°F)
- Electrically test fully assembled luminaires before shipment from factory.
- Effective Projected Area (EPA) and weight of the luminaires shall not exceed 1.4 square feet and 46 lbs.
- Luminaires shall be designed for ease of electrical component replacement.
- Luminaires shall be rated for minimum 2G vibration, minimum, per ANSI C136.31.
- LED light sources and drivers shall be RoHS compliant.
- The luminaire manufacturer shall have no less than five (5) years of experience in manufacturing LED-based lighting products and the manufacturing facility must be ISO 9001 certified.
- Luminaire shall have a 1.25" to 2.0" adjustable tenon mount for connection to luminaire bracket arm assembly.
- Pole hardware, nuts, bolts, and washers, etc. shall be made from 18-8 stainless steel, or steel conforming to ASTM A307 galvanized in accordance with ASTM A153.
- Grommets shall be installed in cable entry holes. Cable entry holes shall be free from sharp edges which might cut conductors or an ungloved hand.
- All conductors inside the luminaire shall be neatly secured with tie-wraps as needed to prevent pinch points and assist in trouble shooting.

B. Driver

- Shall be 0V-10V dimmable.
- Rated case temperature shall be suitable for operation in the luminaire operating in the ambient temperature range of -20°C to +40°C.
- Shall be rated for 480VAC at 50/60 Hz, and shall operate normally for input voltage fluctuations of $\pm 10\%$.
- Shall have a minimum Power Factor (PF) of 0.90 at full input power and across specified voltage range.
- Shall provide UL Class II output.

C. Surge Suppression

- Integral surge protection shall meet ANSI/IEEE C62.45 procedures based on ANSI/IEEE C62.41.2 definitions for standard and optional waveforms for location category C-High 10kV/10kA test, IEC 61000-4-2 (Electrostatic Discharge) 8kV Air/4kV Contact test and IEC 61000-4-4 (Fast Transients).

D. Electromagnetic interference

- Luminaires shall have a maximum Total Harmonic Distortion (THD) of 20% at full input power and across specified voltage range.
- Luminaires shall comply with FCC 47 CFR part 15 non-consumer RFI/EMI standards.

E. Electrical safety testing

- Luminaires shall be listed for wet locations.
- Luminaires shall be UL listed and labeled.

F. Finish

- Luminaires shall be painted with a corrosion resistant polyester powdered paint with a minimum 2.0 mil thickness.
- Luminaires shall exceed a rating of six per ASTM D1654 after 1000 hours of salt spray fog testing per ASTM B117.
- The coating shall exhibit no greater than 30% reduction of gloss per ASTM D523, after 500 hours of QUV testing at ASTM G154 Cycle 6.
- Exterior surfaces shall be smooth and free of burrs.

G. Thermal management

- Mechanical design of protruding external surfaces (heat sink fins) on roadway luminaries shall facilitate hose-down cleaning and discourage debris accumulation.
- Liquids or moving parts will not be allowed for thermal management.

H. Color Quality

- Minimum Color Rendering Index (CRI) of 70 with a Correlated Color Temperature (CCT) of 3000K to 4000K

- I. Optics
 - Transmissive optical components shall be applied in accordance with OEM design guidelines to ensure suitability for the thermal/mechanical/chemical environment.
- J. The following shall be in accordance with corresponding sections of ANSI C136.37
 - All internal components shall be assembled and pre-wired using modular electrical connections.
 - Terminal blocks shall be used for incoming AC lines. Terminal blocks shall be easily accessible to installers or repair personnel. Wire nuts are prohibited inside the luminaire housing.
- K. Latching and hinging
 - Refractor and housing door holders and hinges shall be designed to maintain positive control of door to the luminaire body so as not to allow the accidental disengagement of either door.
 - Drivers shall be mounted to a housing door designed to be opened from the bottom of the luminaire. Housing door shall allow easy removal for troubleshooting/repair on the ground.
- L. Manufacturer or local sales representative shall provide installation and troubleshooting support via telephone and/or email.

2.30 WARRANTY

Provide a minimum ten-year warranty covering maintained integrity and functionality of the luminaire housing, wiring, and connections, LED light source(s) and LED driver. Negligible light output from more than 10 percent of the LED packages constitutes luminaire failure.

Warranty period shall begin after project acceptance by the Department. Supplier shall furnish documentation of warranty procedures to the Design-Build Team stating that the warranty is for NCDOT.

2.40 CONSTRUCTION METHODS

Level and secure each luminaire in all directions. Adjust any luminaires, as directed by the Engineer, to provide optimal illumination distribution.

All LED packages on all luminaires must be operating normally at contract completion. Any luminaire displaying improper operating characteristics prior to contract completion will be replaced by the Design-Build Team at no additional cost to the Department.

3.00 HIGH MAST LIGHT EMITTING DIODE (LED) LUMINAIRES

3.10 DESCRIPTION

Furnish, install and place into satisfactory operation, LED luminaires on high mount standards as detailed in these Special Provisions.

The Design-Build Team shall supply Holophane high mount luminaires as specified below.

Mounting Height	# of Fixtures	Holophane Part Number
120'	8	HMLED3-PK3-40K-HVOLT-G-AW-P7
100'	6	HMLED3-PK3-40K-HVOLT-G-AW-P7
80'	8	HMLED3-PK1-40K-HVOLT-G-AW-P7
60'	4	HMLED3-PK1-40K-HVOLT-G-AW-P7

The Design-Build Team shall supply the Department with current catalog cuts and 3rd party certified photometric data files in Illuminating Engineering Society (IES) format for any alternate high mount luminaire submitted for approval. The Department will thoroughly evaluate alternate luminaires to determine if proposed alternate high mount luminaire meets or exceeds design criteria.

The manufacturer shall state the Light Loss Factor (LLF) used in the photometric calculations for the proposed luminaire. LLF shall be calculated as follows:

$$\text{LLF} = \text{Lamp Lumen Depreciation (LLD)} \times \text{Luminaire Dirt Depreciation (LDD)}$$

- Lamp Lumen Depreciation (LLD) shall be the value calculated and reported by the manufacturer based on the LM-80 and TM-21 reports for the proposed fixture for 70,000 hours at 25° C.
- Luminaire Dirt Depreciation (LDD) = 0.90

High mount luminaire retrofit LED kits are not an acceptable alternative.

3.20 MATERIALS

3.21 LUMINAIRE REQUIREMENTS

A. General Requirements

- LM-79 photometric test reports shall be provided for all LED luminaires. LM-79 luminaire photometric reports shall be produced by an independent test laboratory and include the following:
 - Name of test laboratory. The test laboratory must hold National Voluntary Laboratory Accreditation Program (NVLAP) accreditation for the IES LM-79 test procedure or must be qualified, verified, and recognized through the U.S. Department of Energy's CALiPER program.
 - Report number
 - Date
 - Complete luminaire catalog number. Catalog number tested must match the catalog number of the luminaire submitted, except for variations which do not affect performance.
 - Description of luminaire, LED light source(s), and LED driver(s)
 - Goniophotometry
 - Colorimetry

- LM-80 lumen maintenance test report shall be provided for each respective LED light source.
- Luminaire shall be constructed of aluminum. Each luminaire shall be finished gray in color unless otherwise noted.
- The luminaire shall have a 7 pin ANSI C136.41 compliant photocontrol receptacle for future expansion capabilities.
- Provide a summary of reliability testing performed for LED driver.
- Luminaires maximum total power consumption shall not exceed the values shown in the table above. Nominal luminaire input wattage shall account for nominal applied voltage and any reduction in driver efficiency due to sub-optimal driver loading.
- Luminaire shall have a maximum Backlight, Uplight & Glare (BUG) rating of 5-0-5 and an IESNA distribution of Type V as required to meet the average maintained footcandle level and the average to minimum uniformity ratio requirements shown in the Scope of Work. The same BUG rating and distribution type shall be used throughout the project.
- Luminaire LED modules shall meet dust and moisture rating of IP-66, minimum.
- Luminaire shall have an external label per ANSI C136.15.
- Luminaires shall have an internal label per ANSI C136.22.
- Luminaires shall start and operate in -20°C to +40°C ambient.
- Electrically test fully assembled luminaires before shipment from factory.
- Effective Projected Area (EPA) and weight of the luminaires shall not exceed 1.3 square feet and 65 lbs.
- Luminaires shall be designed for ease of electrical component replacement.
- Luminaires shall be rated for minimum 2G vibration, minimum, per ANSI C136.31-2010
- LED light sources and drivers shall be RoHS compliant.
- The luminaire manufacturer shall have no less than five (5) years of experience in manufacturing LED-based lighting products and the manufacturing facility must be ISO 9001 certified.
- Pole hardware, nuts, bolts, and washers, etc. shall be made from 18-8 stainless steel, or steel conforming to ASTM A307 galvanized in accordance with ASTM A153.

B. Driver

- Shall be 0V-10V dimmable.
- Rated case temperature shall be suitable for operation in the luminaire operating in the ambient temperature range of -20°C to +40°C.
- Shall be rated for 480VAC at 50/60 Hz, and shall operate normally for input voltage fluctuations of $\pm 10\%$.
- Shall have a minimum Power Factor (PF) of 0.90 at full input power and across specified voltage range.

C. Surge Suppression

- Integral surge protection shall meet ANSI/IEEE C62.45 procedures based on ANSI/IEEE C62.41.2 definitions for standard and optional waveforms for location

category C-High 10kV/10kA test, IEC 61000-4-2 (Electrostatic Discharge) 8kV Air/4kV Contact test and IEC 61000-4-4 (Fast Transients).

D. Electromagnetic interference

- Luminaires shall have a maximum Total Harmonic Distortion (THD) of 20% at full input power and across specified voltage range.
- Luminaires shall comply with FCC 47 CFR part 15 non-consumer RFI/EMI standards.

E. Electrical safety testing

- Luminaires shall be listed for wet locations.
- Luminaires shall be UL listed and labeled.

F. Finish

- Luminaires shall be painted with a corrosion resistant polyester powdered paint with a minimum 2.0 mil thickness.
- Luminaires shall exceed a rating of six per ASTM D1654 after 1000 hours of salt spray fog testing per ASTM B117.
- The coating shall exhibit no greater than 30% reduction of gloss per ASTM D523, after 500 hours of QUV testing at ASTM G154 Cycle 6.

G. Thermal management

- Mechanical design of protruding external surfaces (heat sink fins) shall facilitate hose-down cleaning and discourage debris accumulation.

H. Color Quality

- Minimum Color Rendering Index (CRI) of 70 with a Correlated Color Temperature (CCT) of 3000K to 4000K

I. Optics

- Transmissive optical components shall be applied in accordance with OEM design guidelines to ensure suitability for the thermal/mechanical/chemical environment.

J. The following shall be in accordance with corresponding sections of ANSI C136.37

- All internal components shall be assembled and pre-wired using modular electrical connections.
- Terminal blocks shall be used for incoming AC lines
- Latching and hinging

K. Manufacturer or local sales representative shall provide installation and troubleshooting support via telephone and/or email.

3.30 WARRANTY

Provide a minimum ten-year warranty covering maintained integrity and functionality of the luminaire housing, wiring, and connections, LED light source(s) and LED driver. Negligible light output from more than 10 percent of the LED packages constitutes luminaire failure.

The warranty period shall begin after project acceptance by the Department.

3.40 CONSTRUCTION METHODS

Level and secure each luminaire in all directions. Securely terminate the wiring for each high mount luminaire and include an equipment grounding conductor to bond the housing to the supply cord grounding conductor.

Adjust any luminaires, as directed by the Engineer, to provide optimal illumination distribution.

All LED packages on all luminaires must be operating normally at contract completion. Any luminaire displaying improper operating characteristics prior to contract completion will be replaced by the Design-Build Team at no additional cost to the Department.

4.00 LIGHTING CONTROL SYSTEM

4.10 DESCRIPTION

The work covered under this section consists of furnishing and installing an entire control system, including enclosure, control panel, breakers, terminal blocks, wiring, conduits, lightning arrester, a concrete foundation, metal pole and galvanized slotted channel is also included.

The control system will be standard electrical components in a stainless steel enclosure mounted on a metal pole with a concrete foundation as shown in the contract.

4.20 MATERIALS

Refer to Division 10 of the *2018 Standard Specifications*.

Item	Section
Conduit	1091-3
Portland Cement Concrete, Class A	1000-4
Wire and Cable	1091-2, 1400-2

Provide concrete foundations and wire in accordance with the *2018 Standard Specifications for Roads and Structures*.

Use a piece of 4" rigid galvanized steel conduit (RGC), embedded in concrete as shown in the plans, for mounting the control system.

Provide a NEMA type 3R stainless steel enclosure with external stainless mounting flanges, drip shield, back panel and continuous hinge door with a print pocket. Provide a door closing mechanism interlocked with a flange mounted operator handle to prevent the opening of the door with the service circuit breaker in the ON position, except by use of safety override devices.

Provide an enclosure approximately 36" (h) x 30" (w) x 10" (d) unless noted otherwise in the plans. Provide only openings necessary for the entrance of conduits as shown in the plans. Do not use

knockouts. Ensure the enclosure conforms with NEC Article 312 and mount the devices so the NEC clearances will be provided, except use 1.5" where not specified or noted in the tables for minimum wire bending space.

Use minimum 1-5/8" x 1-5/8" galvanized slotted steel framing channel with straps and bolts for the mounting brackets and hardware for attaching the enclosure. Use galvanized finish on the brackets and hardware and coat all field cuts or scratches with organic zinc repair paint.

Provide a neutral bar, bonded to the panel, with sufficient box lug type terminals to accept the required number of wires.

Mount components to the back panel with manufacturer supplied mounting brackets or permanently attached screw studs.

Use a service circuit breaker providing a minimum interrupting rating of 22,000 A. Provide thermal magnetic, molded case, permanent trip breakers. Provide multi-tap, solderless, load side box lugs or distribution terminal blocks of the appropriate size. Use insulating material approved for NEMA 3R applications. Provide a breaker with a voltage and amperage rating as indicated in the plans.

Use feeder circuit breakers which are rated 14,000 A minimum interrupting capacity and have an open type molded case with a non-adjustable thermal magnetic trip setting as noted in the plans.

Use a Type 1 surge protection device (SPD) meeting UL 1449 and UL 96A, designed to contain and arrest an arc of 20,000 A. Install the SPD on the load side of the service breaker.

Use terminals and lugs rated for the connection of the appropriate size copper conductors. All conductors shall be made of copper and neatly wrapped in bundles or run in plastic raceways.

Perform all galvanizing in accordance with Section 1076.

Provide a drawing to scale showing the location, brand and catalog number of each component of the control system for approval. The completed light control system shall be marked "Suitable for Use as Service Equipment", in a prominent location in the enclosure, in accordance with NEC Article 409.110. If the control system is not made in a certified UL 60947-4-1A Panel Shop, a third party, recognized by the Department of Insurance as having the authority, shall label the control systems.

4.30 CONSTRUCTION METHODS

Construct the new control system foundation at the new location as shown in Standard Drawing 1408 of the Roadway Standard Drawings, with the top of the foundation 3 inches above finished grade.

Fasten the enclosure to the pole by means of a galvanized bracket assembly as shown in the plans. Make all cuts square and remove all rough edges. Have mounting holes match existing mounting holes of the enclosure.

Arrange all conduits entering the enclosure in a neat symmetrical manner and extend directly downward into the foundation. Install six RGC feeder circuit conduits as shown in the Roadway Standard Drawings.

Install a Control System Junction Box as shown in the plans. Stub all feeder circuit conduits and spare conduits from Control System in the Control System Junction Box. See Section 1412 of the *2018 Standard Specifications for Roads and Structures* for junction box construction methods. See plans for conduit sizes. Place pull cord in any unused conduits and cap unused conduit in junction box.

To prevent the creation of electrically parallel paths, install a bonded conduit choke on the underground termination point of the system grounding conductor conduit in accordance with NEC Article 250.64(E). Do not terminate the system grounding conduit under the concrete foundation pad.

Install a grounding electrode system consisting of a minimum of two ground rods spaced not less than 6 feet apart at all new lighting control system panels. Connect ground rods with an appropriately sized bonding jumper.

Apply two coats of organic zinc repair paint to all field cut metal and conduit threads as specified in Article 1076-7 of the *2018 Standard Specifications for Roads and Structures*.

Install a 4" to 2" galvanized reducing bushing to the top of the 4" RGC the control system enclosure is mounted to. Install a 10' section of 2" RGC on the reducing bushing and install a cap on the top of the 2" RGC.

5.00 COMMUNICATION GATEWAY

5.10 DESCRIPTION

The Design-Build Team shall provide and install a communication gateway at the lighting control panels noted on the plans. The communication gateway will be used to provide communication from the control nodes on the luminaires to a centralized monitoring software package. The communication gateway will be mounted on a piece of rigid galvanized conduit installed above the lighting control panel.

5.20 MATERIAL

The communication gateway shall be a GE LightGrid gateway rated for the voltage shown in the plans.

Use conduit and conductors as specified in Article 1400-2 of the *2018 Standard Specifications for Roads and Structures*.

Provide stainless steel straps, galvanized conduit hangers, galvanized bolts, washers and nuts, and liquid-tight flexible metallic conduit (LFMC).

5.30 CONSTRUCTION METHODS

Mount the communication gateway to the 2" RGC pole, installed as part of the control system special provision, using the bands included with the gateway. Remove an existing cable gland in the bottom of the gateway enclosure and replace with a ½" RGC fitting. Install ½" RGC and appurtenances required to route conduit to bottom of lighting control panel enclosure. Transition RGC to LFMC to make the turn into the bottom of the enclosure. Secure LFMC to bottom of enclosure using a weatherproof fitting. Install a bonding bushing on the LFMC fitting inside the enclosure and attach to bonding jumper inside the enclosure.

Strap standoffs with rigid conduit hangers to the 2" RGC and secure ½" conduit to the conduit hanger. Install #12 THWN conductors inside the ½" RGC for power from the gateway circuit breaker in the control system enclosure to the gateway. Use a UV resistant cable tie to secure the magnetic GPS antenna to the frame.

See Section 7.00 below for commissioning requirements.

6.00 CONTROL NODE

6.10 DESCRIPTION

The Design-Build Team shall provide and install a communication node with each LED luminaire on the project. The communication node will be used to interface with the Department's Statewide lighting control system.

6.20 MATERIALS

The communication node shall be a GE LightGrid version 2.0 (or higher) node rated for the same service voltage as the luminaire. No other materials are required for this section.

6.30 CONSTRUCTION METHODS

Install communication node on the seven-pin photocell receptacle of the luminaire. The communication node utilizes a twist-lock connection to ensure positive connection to the luminaire.

See Section 7.00 below for commissioning requirements.

7.00 SMART CONTROL SYSTEM INITIALIZATION AND COMMISSIONING

7.10 DESCRIPTION

The Communication Gateway(s) and Control Nodes as described in the prior sections require commissioning to enable communication with the existing Statewide lighting control system.

The Design-Build Team shall coordinate with Brady/Trane Services (Brady) at 919-232-5764 or warranty.request@bradyservices.com to have Brady commission the smart controls system, incorporate new gateways and smart nodes into the LightGrid infrastructure and troubleshoot communication issues. Brady shall bill the Design-Build Team directly for these services.

7.20 MATERIALS

No materials are required for this section.

7.30 CONSTRUCTION METHODS

As part of this contract, the Design-Build Team shall provide new GE LightGrid gateways and control nodes. See Sections 5.00 and 6.00, respectfully, of these Project Special Provisions for gateway and control node requirements.

As a function of the LightGrid system, the Design-Build Team is unable to turn the lights on for testing during the day. The luminaires installed as part of this project are powered 24/7; however, the control node installed on each luminaire has an integral photocontrol, preventing the luminaire from operating during daylight hours.

The Design-Build Team shall notify Brady at least two weeks prior to beginning the construction work. Brady will remotely commission the new LightGrid system, override the internal control node photocontrol and turn all of the control nodes on for 24/7 operation for the duration of the lighting construction. This will allow the Design-Build Team to turn the lighting circuits on and off during the day via the breakers in the lighting control panel.

The Design-Build Team shall notify Brady again when lighting work is complete. At that point Brady will remotely confirm that there is communication between the control nodes and the gateway, and will place the system to normal dusk to dawn operation.

In the event that a communication failure of some, or all, smart nodes or the gateway is encountered, the Design-Build Team shall coordinate with Brady to troubleshoot and resolve the failure.

The Design-Build Team will be reimbursed by the Department for the actual verified cost of charges by Brady for LightGrid service charges. The service charges may include efforts by Brady to: commission the newly installed gateways and control nodes; place the GE LightGrid system into 24/7 operation; place the system in normal dusk to dawn operation; troubleshoot communication issues with the LightGrid system.

ROADWAY LIGHTING FOUNDATIONS

(9-12-17)

DB9 R09

Description

Roadway lighting foundations include foundations for high mount and light standards. High mount foundations for high mount standards and standard foundations for light standards consist of drilled piers or footings with pedestals, conduit and anchor rod assemblies. Construct roadway

lighting foundations in accordance with the contract, 2018 *Roadway Standard Drawings* and accepted submittals. Define “high mount foundation” as a drilled pier including the conduit and anchor rod assembly that meets 2018 Roadway Standard Drawing No. 1402.01. Define “standard foundation” as a drilled pier or footing with pedestal including the conduit and anchor rod assembly that meets 2018 Roadway Standard Drawing No. 1405.01.

Materials

Use roadway lighting foundation materials that meet the *Foundations and Anchor Rod Assemblies for Metal Poles* Project Special Provision found elsewhere in this RFP. Provide metal shrouds for median mounted light standards in accordance with Subarticle 1400-4(I) of the 2018 *Standard Specifications for Roads and Structures*.

Roadway Lighting Foundations

(A) High Mount Foundations

Construct high mount foundations for the wind zone and high mount heights shown in the plans developed by the Design-Build Team unless the following assumed site conditions are not applicable to high mount locations:

- 1) Soil with unit weight (γ) \geq 120 pcf and friction angle (ϕ) \geq 30°,
- 2) Groundwater at least 7 feet below finished grade and
- 3) Slope of finished grade 6:1 (H:V) or flatter.

A subsurface investigation and high mount foundation design are required if the Engineer determines these assumed site conditions do not apply to a high mount location and the high mount cannot be moved. Subsurface conditions requiring a high mount foundation design include but are not limited to weathered or hard rock, boulders, very soft or loose soil, muck or shallow groundwater. No extension of completion date or time will be allowed for subsurface investigations or high mount foundation designs.

(B) Standard Foundations

Construct standard foundation types for the light standard types shown in the plans developed by the Design-Build Team and the site conditions at each light standard location. When weathered or hard rock, boulders or obstructions conflict with standard foundations, submit an alternate standard foundation design for acceptance in accordance with Article 105-2 of the 2018 *Standard Specifications for Roads and Structures*. No extension of completion date or time will be allowed for alternate standard foundations.

Subsurface Investigations

Use a prequalified geotechnical consultant to perform one standard penetration test (SPT) boring in accordance with ASTM D1586 at each high mount location requiring a subsurface investigation.

Rough grade high mount locations to within two feet of finished grade before beginning drilling. Drill borings to two drilled pier diameters below anticipated pier tip elevations or refusal, whichever is higher.

Use the computer software gINT version V8i or later manufactured by Bentley Systems, Inc. with the current NCDOT gINT library and data template to produce SPT boring logs. Provide boring logs sealed by a geologist or engineer licensed in the state of North Carolina.

High Mount Foundation Designs

Design high mount foundations for the wind zone and high mount heights shown in the plans and the slope of finished grade and subsurface conditions at each high mount location. Design drilled piers, footings and pedestals in accordance with the 2013 AASHTO *Standard Specifications for Structural Supports for Highway Signs, Luminaires and Traffic Signals*, 6th Edition, and the latest Interim Specifications.

Design drilled piers for side resistance only in accordance with Section 4.6 of the AASHTO *Standard Specifications for Highway Bridges*. Use the computer software LPILE version 2016 or later manufactured by Ensoft, Inc. to analyze drilled piers. Provide drilled pier designs with a horizontal deflection of less than 0.5" at top of piers.

Design footings in accordance with Section 4.4 of the AASHTO *Standard Specifications for Highway Bridges*. Do not use an allowable bearing pressure of more than 3,000 psf for footings.

Submit boring logs, working drawings and design calculations for acceptance in accordance with Article 105-2 of the 2018 *Standard Specifications for Roads and Structures*. Submit working drawings showing plan views, required foundation dimensions and elevations and typical sections with reinforcement, conduit and anchor rod assembly details. Include all boring logs, design calculations and LPILE output for high mount foundation design submittals. Have high mount foundations designed, detailed and sealed by an engineer licensed in the state of North Carolina.

Construction Methods

Grade around roadway lighting locations with cut and fill slopes as shown on 2018 Roadway Standard Drawing No. 1402.01 or 1405.01. Construct drilled piers, footings and pedestals and install anchor rod assemblies for roadway lighting foundations in accordance with the *Foundations and Anchor Rod Assemblies for Metal Poles* Project Special Provision found elsewhere in this RFP.

For median mounted light standards, place concrete for median barriers and underlying pedestals in the same pour. Construct concrete barriers in accordance with the contract and make concrete median barriers continuous through standard foundations. Coordinate construction of median mounted light standards with sign structures, concrete barriers, drainage structures, etc. to avoid conflicts.

FOUNDATIONS AND ANCHOR ROD ASSEMBLIES FOR METAL POLES

(1-17-12) (Rev. 9-8-17)

DB9 R05

Description

Foundations for metal poles include foundations for signals, cameras, overhead and dynamic message signs (DMS) and high mount and light standards supported by metal poles or upright trusses. Foundations consist of footings with pedestals and drilled piers with or without grade beams or wings. Anchor rod assemblies consist of anchor rods (also called anchor bolts) with nuts and washers on the exposed ends of rods and nuts and a plate or washers on the other ends of rods embedded in the foundation.

Construct concrete foundations with the required resistances and dimensions and install anchor rod assemblies in accordance with the contract and accepted submittals. Construct drilled piers consisting of cast-in-place reinforced concrete cylindrical sections in excavated holes. Provide temporary casings or polymer slurry as needed to stabilize drilled pier excavations. Use a prequalified Drilled Pier Contractor to construct drilled piers for metal poles. Define “excavation” and “hole” as a drilled pier excavation and “pier” as a drilled pier.

This provision does not apply to foundations for signal pedestals; see Section 1743 of the *2018 Standard Specifications for Roads and Structures* and 2018 Roadway Standard Drawing No. 1743.01.

Materials

Refer to the *2018 Standard Specifications for Roads and Structures*.

Item	Section
Conduit	1091-3
Grout, Type 2	1003
Polymer Slurry	411-2(B)(2)
Portland Cement Concrete	1000
Reinforcing Steel	1070
Rollers and Chairs	411-2(C)
Temporary Casings	411-2(A)

Provide Type 3 material certifications in accordance with Article 106-3 of the *2018 Standard Specifications for Roads and Structures* for conduit, rollers, chairs and anchor rod assemblies. Store steel materials on blocking at least 12" above the ground and protect it at all times from damage; and when placing in the work make sure it is free from dirt, dust, loose mill scale, loose rust, paint, oil or other foreign materials. Load, transport, unload and store foundation and anchor rod assembly materials so materials are kept clean and free of damage. Bent, damaged and / or defective materials shall be rejected.

Use conduit type in accordance with the contract. Use Class A concrete for footings and pedestals, Class Drilled Pier concrete for drilled piers and Class AA concrete for grade beams and wings including portions of drilled piers above bottom of wings elevations. Corrugated temporary

casings may be accepted at the discretion of the Engineer. A list of approved polymer slurry products is available from:

connect.ncdot.gov/resources/Geological/Pages/Products.aspx

Provide anchor rod assemblies in accordance with the contract consisting of the following:

- (A) Straight anchor rods,
- (B) Heavy hex top and leveling nuts and flat washers on exposed ends of rods, and
- (C) Nuts and either flat plates or washers on the other ends of anchor rods embedded in foundations

Do not use lock washers. Use steel anchor rods, nuts and washers that meet ASTM F1554 for Grade 55 rods and Grade A nuts. Use steel plates and washers embedded in concrete with a thickness of at least 1/4". Galvanize anchor rods and exposed nuts and washers in accordance with Article 1076-4 of the *2018 Standard Specifications for Roads and Structures*. It is not necessary to galvanize nuts, plates and washers embedded in concrete.

Construction Methods

Install the required size and number of conduits in foundations in accordance with the plans developed by the Design-Build Team and accepted submittals. Construct top of piers, footings, pedestals, grade beams and wings flat, level and within 1" of elevations shown in the plans developed by the Design-Build Team or approved by the Engineer. Provide an Ordinary Surface finish in accordance with Subarticle 825-6(B) of the *2018 Standard Specifications for Roads and Structures* for portions of foundations exposed above finished grade. Do not remove anchor bolt templates or pedestal or grade beam forms or erect metal poles or upright trusses onto foundations until concrete attains a compressive strength of at least 3,000 psi.

(A) Drilled Piers

Before starting drilled pier construction, hold a predrill meeting to discuss the installation, monitoring and inspection of the drilled piers. Schedule this meeting after the Drilled Pier Contractor has mobilized to the site. The Resident or Division Traffic Engineer, Design-Build Team and Drilled Pier Contractor Superintendent shall attend this predrill meeting.

Do not excavate holes, install piles or allow equipment wheel loads or vibrations within 20 feet of completed piers until 16 hours after Drilled Pier concrete reaches initial set.

Check for correct drilled pier alignment and location before beginning drilling. Check plumbness of holes frequently during drilling.

Construct drilled piers with the minimum required diameters shown in the plans developed by the Design-Build Team. Install piers with tip elevations no higher than shown in the plans developed by the Design-Build Team or approved by the Engineer.

Excavate holes with equipment of the sizes required to construct drilled piers. Depending on the subsurface conditions encountered, drilling through rock and boulders may be required. Do not use blasting for drilled pier excavations.

Contain and dispose of drilling spoils and waste concrete as directed and in accordance with Section 802 of the *2018 Standard Specifications for Roads and Structures*. Drilling spoils consist of all materials and fluids removed from excavations.

If unstable, caving or sloughing materials are anticipated or encountered, stabilize holes with temporary casings and / or polymer slurry. Do not use telescoping temporary casings. If it becomes necessary to replace a temporary casing during drilling, backfill the excavation, insert a larger casing around the casing to be replaced or stabilize the excavation with polymer slurry before removing the temporary casing.

If temporary casings become stuck or the Design-Build Team proposes leaving casings in place, temporary casings shall be installed against undisturbed material. Unless otherwise approved, do not leave temporary casings in place for mast arm poles and cantilever signs. The Engineer will determine if casings may remain in place. If the Design-Build Team proposes leaving temporary casings in place, do not begin drilling until a casing installation method is approved.

Use polymer slurry and additives to stabilize holes in accordance with the slurry manufacturer's recommendations. Provide mixing water and equipment suitable for polymer slurry. Maintain the required slurry properties at all times except for sand content.

Define a "sample set" as slurry samples collected from mid-height and within two feet of the bottom of holes. Take sample sets from excavations to test polymer slurry immediately after filling holes with slurry, at least every four hours thereafter and immediately before placing concrete. Do not place Drilled Pier concrete until both slurry samples from an excavation meet the required polymer slurry properties. If any slurry test results do not meet the requirements, the Engineer may suspend drilling until both samples from a sample set meet the required polymer slurry properties.

Remove soft and loose material from bottom of holes using augers to the satisfaction of the Engineer. Assemble rebar cages and place cages and Drilled Pier concrete in accordance with Subarticle 411-4(E) of the *2018 Standard Specifications for Roads and Structures*, except for the following:

- (1) Inspections for tip resistance and bottom cleanliness are not required,
- (2) Temporary casings may remain in place if approved, and
- (3) Concrete placement may be paused near the top of pier elevations for anchor rod assembly installation and conduit placement or

- (4) If applicable, concrete placement may be stopped at bottom of grade beam or wings elevations for grade beam or wing construction.

If wet placement of concrete is anticipated or encountered, do not place Drilled Pier concrete until a concrete placement procedure is approved by the Engineer. If applicable, temporary casings and fluids may be removed when concrete placement is paused or stopped in accordance with the exceptions above provided holes are stable. Remove contaminated concrete from exposed Drilled Pier concrete after removing casings and fluids. If holes are unstable, do not remove temporary casings until a procedure for placing anchor rod assemblies and conduit or constructing grade beams or wings is approved by the Engineer.

Use collars to extend drilled piers above finished grade. Remove collars after Drilled Pier concrete sets and round top edges of piers.

If drilled piers are questionable, pile integrity testing (PIT) and further investigation may be required in accordance with Article 411-5 of the *2018 Standard Specifications for Roads and Structures*. A drilled pier shall be considered defective in accordance with Subarticle 411-5(D) of the *2018 Standard Specifications for Roads and Structures* and drilled pier acceptance shall be based in part on the criteria in Article 411-6 of the *2018 Standard Specifications for Roads and Structures* except for the top of pier tolerances in Subarticle 411-6(C) of the *2018 Standard Specifications for Roads and Structures*.

If a drilled pier is under further investigation, do not grout core holes, backfill around the pier or perform any work on the drilled pier until the Engineer accepts the pier. If the drilled pier is accepted, dewater and grout core holes and backfill around the pier with approved material to finished grade. If the Engineer determines a pier is unacceptable, remediation shall be required in accordance with Article 411-6 of the *2018 Standard Specifications for Roads and Structures*. No extension of completion date or time will be allowed for remediation of unacceptable drilled piers or post repair testing.

Permanently embed a plate in or mark top of piers with the pier diameter and depth, size and number of vertical reinforcing bars and the minimum compressive strength of the concrete mix at 28 days.

(B) Footings, Pedestals, Grade Beams and Wings

Excavate as necessary for footings, grade beams and wings in accordance with the plans developed by the Design-Build Team, accepted submittals and Section 410 of the *2018 Standard Specifications for Roads and Structures*. If unstable, caving or sloughing materials are anticipated or encountered, shore foundation excavations as needed with an approved method. Notify the Engineer when foundation excavation is complete. Do not place concrete or reinforcing steel until excavation dimensions and foundation material are approved by the Engineer.

Construct cast-in-place reinforced concrete footings, pedestals, grade beams and wings with the dimensions shown in the plans developed by the Design-Build Team and in

accordance with Section 825 of the *2018 Standard Specifications for Roads and Structures*. Use forms to construct portions of pedestals and grade beams protruding above finished grade. Provide a chamfer with a 3/4" horizontal width for pedestal and grade beam edges exposed above finished grade. Place concrete against undisturbed soil or backfill and fill in accordance with Article 410-8 of the *2018 Standard Specifications for Roads and Structures*. Proper compaction around footings and wings is critical for foundations to resist uplift and torsion forces.

(C) Anchor Rod Assemblies

Size anchor rods for design and the required projection above top of foundations. Determine required anchor rod projections from nut, washer and base plate thicknesses, the protrusion of three to five anchor rod threads above top nuts after tightening and the distance of one nut thickness between top of foundations and bottom of leveling nuts.

Protect anchor rod threads from damage during storage and installation of anchor rod assemblies. Before placing anchor rods in foundations, turn nuts onto and off rods past leveling nut locations. Turn nuts with the effort of one workman using an ordinary wrench without a cheater bar. Report any thread damage to the Engineer that requires extra effort to turn nuts.

Arrange anchor rods symmetrically about center of base plate locations as shown in the plans developed by the Design-Build Team. Set anchor rod elevations based on required projections above top of foundations. Securely brace and hold rods in the correct position, orientation and alignment with a steel template. Do not weld to reinforcing steel, temporary casings or anchor rods.

Install top and leveling (bottom) nuts, washers and the base plate for each anchor rod assembly in accordance with the following procedure:

- (1) Turn leveling nuts onto anchor rods to a distance of one nut thickness between the top of foundation and bottom of leveling nuts. Place washers over anchor rods on top of leveling nuts.
- (2) Determine if nuts are level using a flat rigid template on top of washers. If necessary, lower leveling nuts to level the template in all directions or if applicable, lower nuts to tilt the template so the metal pole or upright truss will lean as shown in the plans developed by the Design-Build Team. If leveling nuts and washers are not in full contact with the template, replace washers with galvanized beveled washers.
- (3) Verify the distance between the foundation and leveling nuts is no more than one nut thickness.
- (4) Place base plate with metal pole or upright truss over anchor rods on top of washers. High mount luminaires may be attached before erecting metal poles but do not attach cables, mast arms or trusses to metal poles or upright trusses at this time.

- (5) Place washers over anchor rods on top of base plate. Lubricate top nut bearing surfaces and exposed anchor rod threads above washers with beeswax, paraffin or other approved lubricant.
- (6) Turn top nuts onto anchor rods. If nuts are not in full contact with washers or washers are not in full contact with the base plate, replace washers with galvanized beveled washers.
- (7) Tighten top nuts to snug-tight with the full effort of one workman using a 12" wrench. Do not tighten any nut all at once. Turn top nuts in increments. Follow a star pattern cycling through each nut at least twice.
- (8) Repeat (7) for leveling nuts.
- (8) Replace washers above and below the base plate with galvanized beveled washers if the slope of any base plate face exceeds 1:20 (5%), any washer is not in firm contact with the base plate or any nut is not in firm contact with a washer. If any washers are replaced, repeat (7) and (8).
- (10) With top and leveling nuts snug-tight, mark each top nut on a corner at the intersection of two flats and a corresponding reference mark on the base plate. Mark top nuts and base plate with ink or paint that is not water-soluble. Use the turn-of-nut method for pretensioning. Do not pretension any nut all at once. Turn top nuts in increments for a total turn that meets the following nut rotation requirements:

NUT ROTATION REQUIREMENTS (Turn-of-Nut Pretensioning Method)	
Anchor Rod Diameter, inch	Requirement
$\leq 1 \frac{1}{2}$	1/3 turn (2 flats)
$> 1 \frac{1}{2}$	1/6 turn (1 flat)

Follow a star pattern cycling through each top nut at least twice.

- (11) Ensure nuts, washers and base plate are in firm contact with each other for each anchor rod. Cables, mast arms and trusses may now be attached to metal poles and upright trusses.
- (12) Between 4 and 14 days after pretensioning top nuts, use a torque wrench calibrated within the last 12 months to check nuts in the presence of the Engineer. Completely erect mast arm poles and cantilever signs and attach any hardware before checking top nuts for these structures. Check that top nuts meet the following torque requirements:

TORQUE REQUIREMENTS	
Anchor Rod Diameter, inch	Requirement, ft-lb
7/8	180
1	270
1 1/8	380
1 1/4	420
$\geq 1 \frac{1}{2}$	600

If necessary, retighten top nuts in the presence of the Engineer with a calibrated torque wrench to within ± 10 ft-lb of the required torque. Do not overtighten top nuts.

- (13) Do not grout under base plate.

TESTING & ACCEPTANCE

(5-24-18)

(A) GENERAL TEST PROCEDURE

Test the DMS in a series of design approval and functional tests. Any reference to “DMS” shall refer both to color and monochrome DMS. The results of each test must meet the specified requirements. These tests shall not damage the equipment. The Engineer will reject equipment that fails to fulfill the requirements of any test. Resubmit rejected equipment after correcting non-conformities and re-testing; completely document all diagnoses and corrective actions. Modify all equipment furnished under this contract, without additional cost to the North Carolina Department of Transportation, to incorporate all design changes necessary to pass the required tests.

Provide four copies of all test procedures and requirements to the Engineer for review and approval at least 30 days prior to the testing start date. Use only approved procedures for the tests. Include the following in the test procedures:

- A step by step outline of the test sequence, showing a test of every function of the equipment or system tested
- A description of the expected nominal operation, output, and test results, and the pass / fail criteria
- An estimate of the test duration and a proposed test schedule
- A data form to record all data and quantitative results obtained during the test
- A description of any special equipment, setup, manpower, or conditions required by the test

Provide all necessary test equipment and technical support. Use test equipment calibrated to National Institute of Standards and Technology (NIST) standards. Provide calibration documentation upon request.

Conform to these testing requirements and the requirements of these specifications. The Engineer will reject all equipment not tested according to these requirements. It is the Design-Build Team's responsibility to ensure the system functions properly even after the Engineer accepts the DMS test results.

Provide four copies of the quantitative test results and data forms containing all data taken, highlighting any non-conforming results and remedies taken, to the Engineer for approval. An authorized representative of the manufacturer must sign the test results and data forms.

(B) DESIGN APPROVAL TESTS

1. DMS System

Design Approval Tests are applicable to DMS systems not currently on the QPL.

The Design Approval Tests consists of all tests described in Section 2.2 "DMS Equipment Tests" of NEMA TS 4-2005 (Hardware Standards for Dynamic Message Signs with NTCIP Requirements). Perform all tests and submit certified results for review and approval.

PROTOTYPE – Manufacture a prototype DMS and controller of the type and size described in the Project Special Provisions. In the presence of the Engineer, test the prototype according to the Design Approval and Operational Tests. When all corrections and changes (if any) have been made, the Department may accept the prototype DMS and controller as the physical and functional standard for the system furnished under this contract. You may use the prototype units on this project if, after inspection and rework (if necessary), they meet all physical and functional specifications. In the case of standard product line equipment, if the Design-Build Team can provide test results certified by an independent testing facility as evidence of prior completion of successful design approval tests, then the Engineer may choose to waive these tests.

In each Design Approval Test, successfully perform the Functional Tests described below. Apply the extreme conditions to all associated equipment unless stated otherwise in these Project Special Provisions.

(C) OPERATIONAL FIELD TEST (ON-SITE COMMISSIONING)

1. DMS System

Conduct an Operational Field Test of the DMS system installed on the project to exercise the normal operational functions of the equipment. The Operational Field Test will consist of the following tests as a minimum:

Physical Examination

Examine each piece of equipment to verify that the materials, design, construction, markings, and workmanship comply with the mechanical, dimensional, and assembly requirements of these Project Special Provisions.

Perform the following tests as a minimum:

- Verify that all surfaces are free of dents, scratches, weld burns, or abrasions. Round sharp edges and corners.
- Verify bend radius of cables is not excessive or could potentially cause damage.
- Verify all modules, lamps, and components are properly secured.
- Verify that there are no exposed live terminals.

Continuity Tests

Check the wiring to assure it conforms to the requirements of these Project Special Provisions.

Functional Tests

Perform the following functional tests:

- Start-up and operate the DMS locally using a laptop computer
- Use automatic (photo-electric sensor controlled) DMS Control Software to switch between “dim”, “normal”, and “bright” light levels
- Operate the DMS with all display elements flashing continuously for 10 minutes at the maximum flash rate
- Exercise the DMS by displaying static messages, flashing messages, and alternating static and flashing message sequences
- Automatic poll the DMS by the Control Software at various intervals and verify the data received by Control Software from DMS
- Download and edit messages using Control Software
- Execute status request on the DMS controller
- Observe normal operations during uploading and downloading messages
- Input and select messages from the sign controller’s local user interface
- Test sequence activation at chosen intervals
- Display and verify all stored messages

- Verify resumption of standard operation upon interruption of electrical power
- Demonstrate detected failures and response functions
- Demonstrate proper operation of the Failure Log
- Set controller clock using the Control Software
- Execute system shutdown using the Control Software and local user interface
- Verify detection of a power failure in the DMS enclosure and the report feature of the failure to the Control Software
- Display IP address and web settings,
 - Verify that the IP address is not publicly accessible. Placing a display on a private network or VPN helps mitigate the lack of security
 - Disable the telnet, Web Interface, Web LCD, and ICMP (PING) interfaces
 - Change the default password
- Set the controller to enable a controller log file

Approval of Operational Field Test results does not relieve the Design-Build Team to conform to the requirements in these Project Special Provisions. If the DMS system does not pass these tests, document a correction or substitute a new unit as approved by the Engineer. Re-test the system until it passes all requirements.

2. Fiber-Optic Communications

Conduct bi-directional optical time domain reflectometer (OTDR) on each fiber, including unused fibers, in accordance with Section 1731-3 of the *Standard Specifications*. Ensure that attenuation ratings are in accordance with Section 1098-10 of the *Standard Specifications*.

(D) 30-DAY OBSERVATION PERIOD

The 30-Day Observation Period shall be considered part of work to be completed by the project completion date.

Upon successful completion of all project work, the component tests, the System Test, and the correction of all deficiencies, including minor construction items, the 30-day Observation Period may commence. This observation consists of a 30-day period of normal, day-to-day operations of the new field equipment in operation with the new central equipment without any failures. The purpose of this period is to ensure that all components

of the system function in accordance with the plans developed by the Design-Build Team and these Project Special Provisions.

Respond to system or component failures (or reported failures) that occur during the 30-day Observation Period within twenty-four (24) hours. Correct said failures within forty-eight (48) hours. Any failure that affects a major system component as defined below for more than forty-eight (48) hours will suspend the timing of the 30-day Observation Period beginning at the time when the failure occurred. After the cause of such failures has been corrected, timing of the 30-day Observation Period will resume. System or component failures that necessitate a redesign of any component or failure in any of the major system components exceeding a total of three (3) occurrences will terminate the 30-day Observation Period and cause the 30-day Observation Period to be restarted from day zero when the redesigned components have been installed and/or the failures corrected. The major system components are:

- DMS Field Controller and Display Module
- Fiber-optic Communications Cables and Splices

(F) FINAL ACCEPTANCE

Final system acceptance of the ITS is defined as the time when all work and materials described in the plans developed by the Design-Build Team and these Project Special Provisions have been furnished and completely installed by the Design-Build Team; all parts of the work have been approved and accepted by the Engineer; and the 30-day observation period has been successfully completed.

The project will be ready for final acceptance of ITS upon the satisfactory completion of all tests detailed in this Section of the Project Special provisions; the rectification of all punch-list discrepancies; and the submittal of all project documentation.

WORK ZONE PATTERN MASKING

(8-25-15) (Rev. 8-29-18)

Description

In accordance with this RFP, the Design-Build Team shall furnish and install Work Zone Pattern Masking material on roadways identified in the Transportation Management Scope of Work. The material shall be placed on existing asphalt pavements during work zone operations. Work Zone Pattern Masking material shall be black in color and used during traffic pattern changes to completely cover the entire pavement surface; thus masking/concealing the existing pavement markings and establishing a newly black surface for the placement of the work zone “performance” pavement markings. Work Zone Pattern Masking eliminates the grind marks and “ghost markings” on pavement surfaces, which can create motorist confusion and pavement damage, while providing

an incomparable contrast between the revitalized black pavement color and newly applied work zone “performance” pavement markings.

Materials

A) General

Use materials in accordance with Manufacturer’s recommendations that will retain a black color for a period of at least 12 months. The Work Zone Pattern Masking material shall completely mask/conceal the existing pavement markings for the same 12-month period.

The black material shall be a flat black color when fully cured. The material shall not exhibit glare or retroreflectance in either day or night conditions. To ensure the material provides ample concealment and does not exhibit excessive glare, the material opaqueness shall be a minimum of 95% and the retroreflective properties shall not exceed 4 mcd/lux/m².

It shall not adversely affect the ability of the pavement to drain water or make the pavement adversely slick in either dry and wet conditions and shall meet the skid properties as described in Section C below.

The material shall not contain any petroleum components and shall not contain any Volatile Organic Compounds (VOC’s).

The material shall not exhibit excessive cracking or create excessive cracking to the pavement surface after placement.

It shall be manufactured to bond successfully to asphalt pavements and allow resurfacing treatments to be applied directly over its surface without having to be removed for successful bonding of the new asphalt overlays.

It should also be manufactured to receive any type of polyurea, epoxy, polymer, cold applied plastic or thermoplastic pavement marking materials.

B) Material Qualifications / Certifications

Use Work Zone Pattern Masking materials that are on the NCDOT Approved Products List. Provide a Type 3 (Manufacturers) Certification in accordance with Section 106-3 in the North Carolina Standard Specifications for Roads and Structures to ensure the material meets or exceeds the requirements in this specification.

In addition, provide a Type 5 (Typical Certified Test Report) Certification in accordance with Section 106-3 in the North Carolina Standard Specifications for Roads and Structures that ensures the material has been tested by an independent testing company that meets or exceeds the braking/skid requirements as described in Section C below.

C) Performance

The Work Zone Pattern Masking material shall be tested by an independent test laboratory for skid properties according to the test standards in ASTM E274 or ASTM E303-93 (2008). The material

shall provide minimum frictional resistance numbers when tested with either test standard. The minimum average Skid Number (SN) for ASTM E274 is 37. The minimum average British Pendulum Number (BPN) for ASTM E303-93 (2008) is 37.

The work zone travel lane shall retain its black distinguishable appearance throughout the life of the traffic pattern. Normal wearing is expected in the wheel paths of the travel lanes, but the work zone travel lanes shall always have a noticeable black appearance at all times during the expected 12-month traffic pattern life.

At any time this material fails to keep previously installed pavement markings concealed, resulting in conflicting traffic patterns or does not retain its black color contrast for the required 12-month duration, it is not meeting the requirements and intention of this specification and shall be replaced immediately.

If the Work Zone Pattern Masking material is snowplowed within its 12 month expected life, the material shall withstand a single snow event, retain its black color and continue to conceal the pavement markings underneath.

If the work zone experiences more than 1 snowplowing event, the Engineer will determine if the Work Zone Pattern Masking is still performing adequately or if replacement is necessary due to excessive damage caused by snowplow activities. If the material is damaged to the point where 20% or more of the concealed pavement markings are revealed, it shall be replaced at an 8" width to re-conceal the exposed pavement markings. This work will be paid for as extra work in accordance with Subarticle 104-8-(A) of the NCDOT 2018 *Standard Specifications for Roads and Structures* at the unit price of \$0.50 per linear foot, unless the traffic pattern is to change within 30 days.

Poor performance of Work Zone Pattern Masking material at any site, whether or not related to a specific contract may be grounds for removing the material from the NCDOT Approved Products List and or removing from any project under contract.

Construction Methods

A) Application Equipment

The equipment to apply Work Zone Pattern Masking material shall be truck mounted pneumatic or airless spray machines with suitable arrangement of atomizing nozzles and controls to cover the entire pavement surface to achieve uniform coverage with consistent thickness as required in this specification. Do not use hand applied methods or any other non-truck mounted application equipment or device to install material for applications longer than 1,000 feet.

The application spray equipment shall be set up in such a manner to apply the Work Zone Pattern Masking material in spray pattern widths to ensure complete and uniform coverage of the entire travelway and to reduce the overlap from multiple passes. If the application equipment is not equipped to spray a full 12' travel lane in a single pass, it shall be set-up to spray a 6-foot minimum width. A 1" overlap width is required when applying the material in less than the full width of the travel lane.

B) Material Application

The Work Zone Pattern Masking material is to be applied to the full width and length of the pavement surface where traffic patterns are to change, thus masking/concealing the existing pavement markings, as well as providing a new black surface for the placement of the revised pavement markings.

The Work Zone Pattern Masking material shall be applied to the pavement markings being concealed in 2 separate applications. The first application shall be applied directly onto the existing pavement markings at a width equivalent to the width of the markings being concealed at a uniform thickness of 20 mils. This application doesn't require the application of anti-skid elements. The second application shall be applied on the pavement markings being concealed as well as the entire pavement width at a uniform thickness of 20 mils along with the anti-skid elements at a rate of 8 lbs/gallon or greater.

The Contractor has the option of applying the 2 coat masking application to the pavement markings in separate passes or in a single pass depending on how the application equipment is configured.

The masking / concealment of individual pavement marking edge lines, skips, mini skips, lane lines or gore lines shall be prohibited.

The material shall be set and / or cured in order to receive pavement markings within 10 minutes of installation according to the temperature requirements stated within this specification.

C) Surface Preparation

- **Asphalt Pavements** - The existing pavement surface shall be swept clean and prepared in accordance with the Manufacturer's recommendations to receive the Work Zone Pattern Masking material. Although no existing pavement marking line removal is required, any loose, flaking, or other laitance material including residual / loose or raised glass beads from existing markings shall be machine broomed or scarified as directed by the Manufacturer before placing the Work Zone Pattern Masking material.

NOTES: For newly placed concrete pavements, newly installed concrete bridge decks or existing concrete pavements that do not receive a surface treatment, Work Zone Pattern Masking material shall not be placed. The conflicting pavement marking lines shall be removed by water blasting methods only.

D) Temperature and Weather Limitations

Do not apply Work Zone Pattern Masking material unless the ambient air temperature and the pavement temperature is 40°F or higher. Do not install unless the pavement surface is completely dry and not within 4 hours of a significant rain event such as a thunderstorm with rainfall intensities greater than 1 inch/per hour. Always follow the Manufacturer's recommendations for placement during periods of excessive humidity.

Maintenance

There should be no required maintenance of the Work Zone Pattern Masking material. Replace any Work Zone Pattern Masking material that prematurely fails to keep pavement markings masked/concealed for the full 12-month duration. Any traffic control or material costs due to replacement will be at no cost to the Department, unless it is due to excessive damage caused by snowplow damage.

HIGH VISIBILITY TRAFFIC CONTROL DEVICES

(1/9/2019)

Description

In accordance with this RFP, the Design-Build Team shall furnish and install High Visibility devices for projects on Interstates and Freeways with durations of 24 months or more. High Visibility devices include drums, stationary work zone signs and portable work zone signs. All of these devices shall be new. Used devices are not acceptable.

The purpose of High Visibility devices is to enhance the conspicuity of the devices in order to improve both safety and mobility through the Interstate and Freeway work zones. In addition, using new devices help to ensure they remain in compliance with required retroreflective properties for the full life of the project and to improve the overall appearance of Significant Work Zones throughout the State.

Materials

A) General

Use materials in accordance with the Manufacturer's recommendations that will retain both durability and retroreflectivity as described elsewhere in this project special provision for a period of at least 36 months.

The following are required High Visibility devices to be used for Work Zone Performance applications.

- Drums (Type XI fluorescent orange sheeting)
- Stationary Work Zone Signs
- Rigid Portable Work Zone Signs

All drums shall be new and meet the existing requirements of Section 1089-5 of the 2018 NCDOT *Standard Specifications for Roads and Structures* and shall have Type XI fluorescent orange sheeting that meets the retroreflective requirements of Section 1092-2 of the 2018 NCDOT *Standard Specifications for Roads and Structures*.

All stationary work zone signs shall be new and meet the existing requirements of Section 1089-1 of the 2018 NCDOT *Standard Specifications for Roads and Structures*. Legend overlays are prohibited and shall not be accepted on the Interstate/Freeway or associated intersecting roadways.

All portable work zone signs shall be new and have composite substrates as described in Section 1089-1 of the 2018 NCDOT *Standard Specifications for Roads and Structures*. The remainder of the existing requirements of Section 1089-1 of the 2018 NCDOT *Standard Specifications for Roads and Structures* remain. Used sign stands are acceptable.

B) Material Qualifications / Certifications

Only use materials as listed above that are on the NCDOT Approved Products List. In addition, provide a Type 3 Material Certification for all materials in accordance with Section 106-3 and Section 1087-4 of the 2018 NCDOT *Standard Specifications for Roads and Structures*.

(C) Performance

Poor performance of any device or sign at any site, whether or not related to a specific contract may be grounds for removing the material from the NCDOT Approved Products List and / or removing from any project under contract.

Construction Methods

All requirements of Section 1110-3 and Section 1130-3 of the 2018 NCDOT *Standard Specifications for Roads and Structures* shall apply except roll up signs are not permitted for use. The use of skinny drums are prohibited for any nighttime lane closures on Interstates and Freeways.

Maintenance

Replace any sign or drum that prematurely fails due to any damage or defect that causes it to perform unsatisfactorily with an “in kind” device of similar quality and age according to the guidelines set forth in the American Traffic Safety Service Association’s (ATSSA) Quality Guidelines for Work Zone Traffic Control Devices. An “in kind” replacement sign or drum is not required to be new, however, it shall be less than 1 year old and have 100% of its original sheeting area and at least 85% of the retroreflective qualities of a new device, so that it is undetectable adjacent to the original devices and signs placed on the project.

SEQUENTIAL FLASHING WARNING LIGHTS

(10/08/2016)

Description

In accordance with this RFP, the Design-Build Team shall furnish and install Sequential Flashing Warning Lights on drums used for merging tapers during nightly work activities on interstates and freeways with speed limits greater than 55 MPH. Reference the *Transportation Management Scope of Work* elsewhere in this RFP for required facilities.

The purpose of these lights is to assist the motorist in determining which direction to merge when approaching a lane closure. It’s also designed to reduce the number of late merges resulting in devices being struck and having to be reset to maintain positive guidance at the merge point. The

successive flashing of the lights shall occur from the upstream end of the merging taper to the downstream end of the merging taper in order to identify the desired vehicle path.

Materials

The Sequential Flashing Warning Lights shall meet all of the requirements for warning lights within the current edition of the Manual of Uniform Traffic Control Devices (MUTCD).

Each light unit shall be capable of operating fully and continuously for a minimum of 200 hours when equipped with a standard battery set.

Each light in the sequence shall be flashed at a rate of not less than 55 times per minute and not more than 75 times per minute. The flash rate and flash duration shall be consistent throughout the sequence.

Supply a Type 3 Certification (Independent Test Lab results) documenting all actual test results for the specified parameters contained in the Institute of Transportation Engineer's (ITE's) *Purchase Specification for Flashing and Steady Burn Warning Lights*. The laboratory shall also identify all manufacturer codes and part numbers for the incandescent lamp or LED clusters, lenses, battery, and circuitry, and the total width of the light with the battery in place. The complete assembly shall be certified as crashworthy when firmly affixed to the channelizing device.

All Sequential Flashing Warning Lights shall be on the NCDOT Work Zone Traffic Control Approved Products List.

Construction Methods

Sequential Flashing Warning Lights are to be used for night time lane closures.

These lights shall flash sequentially beginning with the first light and continuing until the final light.

The Sequential Flashing Warning Lights shall automatically flash in sequence when placed on the drums that form the merging taper.

The number of lights used in the drum taper shall equal the number of drums used in the taper.

Drums are the only channelizing device allowed to mount sequential flashing warning lights.

The Sequential Flashing Warning Lights shall be weather independent and visual obstructions shall not interfere with the operation of the lights.

The Sequential Flashing Warning Lights shall automatically sequence when placed in line in an open area with a distance between lights of 10 to 100 feet. A 10 foot stagger in the line of lights shall have no adverse effect on the operation of the lights.

If one light fails, the flashing sequence shall continue. If more than 1 light fails, all of the lights are to be automatically turned to the “off” mode. Non-sequential flashing is prohibited.

When lane closures are not in effect, the Sequential Flashing Warning Lights shall be deactivated.

SEQUENTIAL FLASHING WARNING LIGHTS

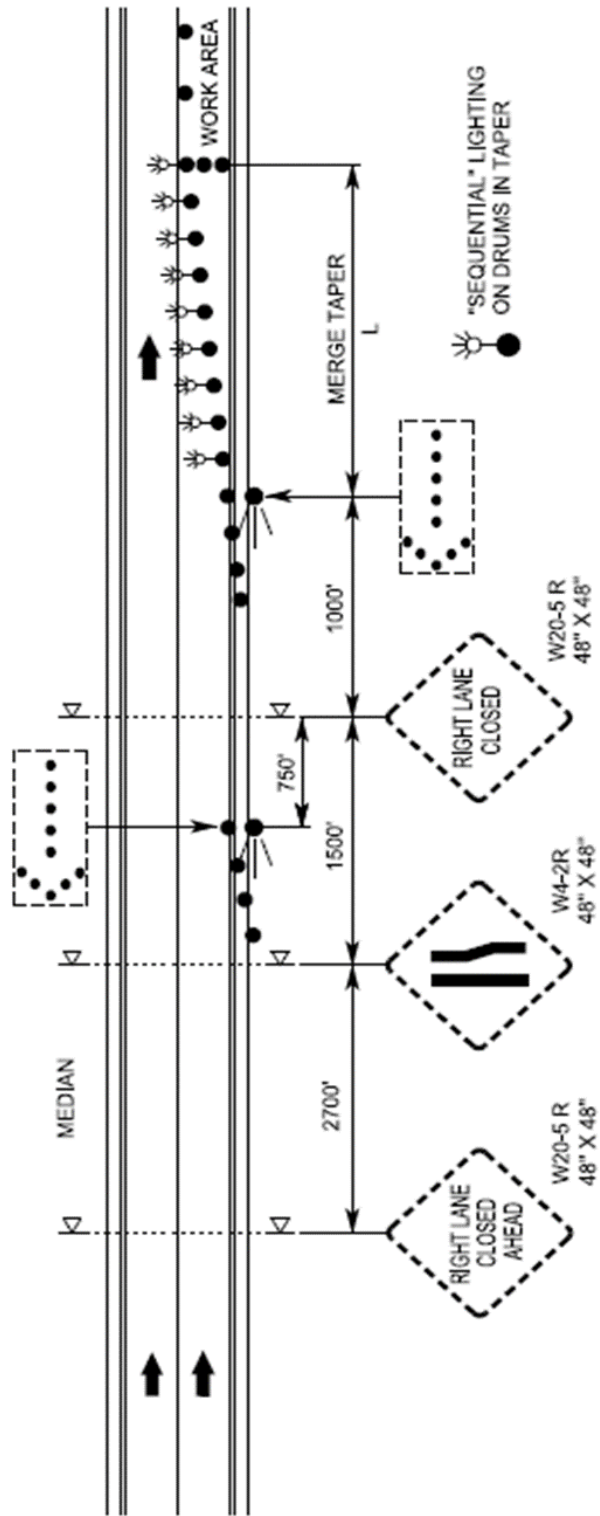

GENERAL

The State will not be bound by oral explanations or instructions given at any time during the bidding process or after award. Only information that is received in response to this RFP will be evaluated; reference to information previously submitted will not suffice as a response to this solicitation.

NO CONTACT CLAUSE

To ensure that information is distributed equitably to all short-listed Design-Build Teams, all questions and requests for information shall be directed to the State Contract Officer through the Design-Build e-mail address. This precludes any Design-Build team member, or representative, from contacting representatives of the Department, other State Agencies or Federal Agencies either by phone, e-mail or in person concerning the Design-Build Project.

USE OF TERMS

Throughout this RFP and all manuals, documents and standards referred to in the RFP the terms Contractor, Bidder, Design-Builder, Design-Build Team, Team, Firm, Company and Proposer are synonymous.

Throughout this RFP and all manuals, documents and standards referred to in the RFP, the terms NCDOT, NCTA, Department, Engineer and State are synonymous.

Throughout this RFP and all documents referred to in the RFP, references to the Technical Proposal include all Technical Proposal supplemental information that may be submitted in response to a Best and Final Offer RFP.

DESIGN REFERENCES

Design references developed and published by NCDOT and those developed and published by other agencies and adopted for use by NCDOT which are to be used in the design of this project may be obtained by contacting the Contract Standards and Development Unit within the Technical Services Division. Standard prices for materials, which the Department normally sells for a fee, will be in effect. The Design-Build Team shall be responsible for designing in accordance with the applicable documents and current revisions and supplements thereto.

REVIEW OF SUBMITTALS

Major design milestones and required design submittals shall be identified as activities on a Project Schedule. This schedule shall be submitted to the NCTA and Resident Engineer concurrently with the first design submittal, or within 30 days of the contract award, whichever is earlier. The schedule shall be revised and resubmitted as design milestones change or as directed by the NCTA. Submittals will be reviewed within ten working days (15 days for temporary structures, overhead sign assemblies, MSE walls, FEMA compliance documents, curved steel girder working drawings and temporary shoring) from the date of receipt by NCTA unless otherwise stipulated in the scope of work. All submittals shall be prepared and submitted in accordance with the *NCTA Design-Build Submittal Guidelines*, which by reference are

incorporated and made a part of this contract. All submittals shall be made simultaneously to the NCTA and the Resident Engineer through a sharepoint or similar site. The Department will not accept subsequent submittals until prior submittal reviews have been completed for that item. The Design-Build Team shall inform the NCTA in writing of any proposed changes to the NCDOT preliminary designs, Technical Proposal and/or previously reviewed submittals and obtain approval prior to incorporation. The Design-Build Team shall prioritize submittals in the event that multiple submittals are made based on the current schedule. All submittals shall include pertinent Special Provisions. No work shall be performed prior to NCTA review and acceptance of the design submittals.

It is anticipated that most, if not all, design submittals will be made electronically and responded to electronically.

OVERVIEW

The Design-Build Project, R-2721A, is the extension of the Triangle Expressway from the end of the existing Triangle Expressway to just east of Pierce Olive Road in Wake County. The total project length is approximately 4.3 miles. The project will construct a 70 mph (posted) six-lane facility with two interchanges.

Project services shall include, but are not limited to:

- **Design Services** – completion of construction plans
- **Construction Services** – necessary to build and ensure workmanship of the designed facility
- **Intelligent Transportation Systems** – design and construction of certain ITS infrastructure
- **All Electronic Tolling** – design and construction of certain infrastructure for all electronic tolling
- **Permit Preparation / Application** - development of all documents for any required permit modifications
- **Right of Way** – acquisition of right of way necessary to construct project to the extent described in the *Right of Way Scope of Work*
- **As-Constructed Drawings**
- **As-Built Plans**

Construction Engineering Inspection will be provided by the NCDOT Division personnel or will be performed under a separate contract.

The Final Environmental Impact Statement was signed in December 2017. The Record of Decision was signed in June of 2018.

GENERAL SCOPE

The scope of work for this project includes design, construction and management of the project. The design work includes all aspects to construct approximately 4.3 miles of a six-lane divided toll facility. Unless allowed otherwise elsewhere in this RFP, the designs shall meet all appropriate latest versions of AASHTO *Policy on Geometric Design of Highways and Streets*, AASHTO *LRFD Bridge Design Specifications*, *Manual of Uniform Traffic Control Devices* and

all NCDOT design policies that are current as of the Technical and Price Proposal submittal date or the Best and Final Offer submittal date, whichever is later.

Unless noted otherwise elsewhere in this RFP, all documents referenced herein shall be the edition/version, including all interim revisions, effective on the Technical Proposal submittal date.

Construction shall include, but not be limited to, all necessary clearing, grading, roadway, drainage, structures, AET, ITS, utility coordination and relocation, and erosion and sediment control work items for the proposed six-lane facility and installation of the control of access fence. Construction engineering and management shall be the responsibility of the Design-Build Team. Construction shall comply with 2018 NCDOT *Standard Specifications for Roads and Structures* and any special provisions.

Areas of work required for this project shall include, but are not limited to the following items:

- Roadway Design
- Structure Design
- Hydraulic Design
- Permit Application/Modification
- Subgrade Stabilization
- Foundation Design for Structures and Roadway
- Erosion and Sedimentation Control Design and Implementation
- R/W Utilities, Conflicts and/or Construction
- Transportation Management Plan Design and Implementation
- Pavement Marking Design
- Sign Design and Installation
- ITS Design and Installation
- All Electronic Tolling Infrastructure
- Traffic Management and Signal System Design and Installation
- Construction
- Project Management
- Design and Construction Management
- Construction Surveying
- Location and Surveys
- On-Site Mitigation
- Lighting Design and Installation
- Right of Way Acquisition (to the extent described in the *Right of Way Scope of Work*)
- Public Information

All designs shall be in Microstation format using Geopak software (current version used by the Department).

DESIGN AND CONSTRUCTION PERFORMED BY DESIGN-BUILD TEAM

The design work consists of the preparation of all construction documents for constructing approximately 4.3 miles of a six-lane divided toll facility as outlined in the various Scopes of

Work of this RFP. The Design-Build Team shall prepare final designs, construction drawings and special provisions.

Unless noted otherwise elsewhere in this RFP, the Design-Build Team shall acknowledge that project documents furnished by the NCTA and the Department are preliminary and provided solely to assist the Design-Build Team in the development of the project design. The Design-Build Team shall be fully and totally responsible for the accuracy and completeness of all work performed under this contract and shall save the State harmless and shall be fully liable for any additional costs and all claims against the State which may arise due to errors, omissions and negligence of the Design-Build Team in performing the work required by this contract.

There shall be no assignment, subletting or transfer of the interest of the Design-Build Team in any of the work covered by the Contract without the written consent of the State, except that the Design-Build Team may, with prior written notification of such action to the State, sublet property searches and related services without further approval of the State.

The Design-Build Team shall certify all plans, specifications, estimates and engineering data furnished by the Team.

All work by the Design-Build Team shall be performed in a manner satisfactory to the State and in accordance with the established customs, practices, and procedures of the North Carolina Department of Transportation, and in conformity with the standards adopted by the American Association of State Highway Transportation Officials, and approved by the U.S. Secretary of Transportation as provided in Title 23, U.S. Code, Section 109 (b). The decision of the Engineer / State / Department shall control in all questions regarding location, type of design, dimension of design, and similar questions.

Alternate designs, details and/or construction practices (such as those employed by other states, but not standard practice in NC) are subject to NCTA review and approval, and will be evaluated on a case by case basis.

The Design-Build Team shall not change team members, subconsultants or subcontractors identified in the Statement of Qualifications (SOQ) or Technical Proposal without written consent of the Engineer or the State Contract Officer. In addition, subconsultants and subcontractors not identified in the SOQ or Technical Proposal shall not perform any work without written consent by the Engineer. Individual offices of the Design-Build Team not identified in the Statement of Qualifications or the Technical Proposal submitted shall not perform any work without written consent by the Engineer. Failure to comply with this requirement may be justification for removing the Team from further consideration for this project and disqualification from submitting on future Design-Build Projects.

All firms shall be prequalified by the Department for the work they are to perform. Joint Ventures, LLCs or any legal structure that are different than the existing prequalification status must be prequalified prior to the Price Proposal submittal deadline. Subcontractors need only be prequalified prior to performing the work. Design firms should be prequalified prior to the Technical Proposal submittal deadline. If not prequalified at the time of the Technical Proposal submittal deadline, the prime contractor shall be solely responsible for either (1) ensuring that

the design firm is prequalified prior to its first design submittal or (2) replacing that firm with a prequalified firm.

ACCESS TO PROVIDED MATERIALS

To facilitate distribution of documents that may be helpful to the Design-Build Teams in their development of a Technical and Price Proposal and subsequent designs, project material will be made accessible through a secure web portal. The Design-Build Project Manager for each short-listed team shall provide a list of team members that will require access to this portal. This list shall include the name, e-mail address and North Carolina Identity Management (NCID) for each individual team member. Once the list is complete, it shall be submitted to the Design-Build e-mail address (designbuild@ncdot.gov). No distribution of Provided Materials will be possible prior to this list being submitted and the access privileges established as noted herein.

To create an NCID account, each individual shall go to NCDOT's Connect website (<https://connect.ncdot.gov>) and click on the "How to get an Account" link and then, "Create NCID".

The Department will obtain access rights for these individuals and notify the Design-Build Project Manager accordingly. Individuals may then re-enter the "Connect" site and login with their NCID account. Once logged in, the Teamsite "R-2721A Project" link will be apparent on the left side of the webpage.

Please note that all material provided, including the material provided through this portal, is provided for informational purposes only and is provided solely to assist the Design-Build Team in the development of the project design unless noted otherwise elsewhere in this RFP. By submitting a Technical Proposal and Price Proposal, the Design-Build Team acknowledges that they are fully and totally responsible for the project design, including the use of portions of the Department design, modification of such design, or other designs as may be submitted by the Design-Build Team, unless noted otherwise elsewhere in this RFP. The Design-Build Team further acknowledges that they are fully and totally responsible for the accuracy and completeness of all work performed, including the determination of the accuracy of the information provided through this portal, and to the extent that the Design-Build Team chooses to rely on such information.

ELECTRONIC PLAN SUBMITTALS AND E-SIGNATURES

The Design-Build Team shall submit all Release for Construction Plans in accordance with the NCDOT e-Signature requirements, including but not limited to providing signed and sealed searchable .pdf files. Reference the website noted below for additional information:

<https://connect.ncdot.gov/projects/roadway/pages/private-engineering-firm-resources.aspx>

ETHICS POLICY

Employees employed by the Design-Build Team or employees employed by any subconsultant for the Design-Build Team to provide services for this project shall comply with the Department's Ethics Policy. Failure to comply with the Ethics Policy will result in the

employee's removal from the project and may result in removal of the Company from the Department's appropriate prequalified list.

APPROVAL OF PERSONNEL

The Department will have the right to approve or reject any personnel, assigned to a project by the Design-Build Team.

In the event of engagement of a former employee of the Department, the Design-Build Team or their subcontractors shall restrict such person or persons from working on any of the Design-Build Team's contracted projects in which the person or persons were "formerly involved" while employed by the State. The restriction period shall be for the duration of the contracted project with which the person was involved. *Former Involvement* shall be defined as active participation in any of the following activities:

- Drafting the contract or contract Scopes of Work
- Design-Build Team selection
- Negotiation of the contract cost (including calculating manhours or fees)
- Contract administration

An exception to these terms may be granted when recommended by the Secretary and approved by the Board of Transportation.

The Design-Build Team and their subconsultants / subcontractors shall restrict all personnel embedded within the Department, including but not limited to Design Units and Divisions, from working on any Design-Build procurement / project. Except as allowed otherwise below, the Design-Build Team shall provide a list of all embedded personnel to the Department and a signed Confidentiality Agreement for each embedded employee, as well as their employer and NCDOT Unit Manager. If the Design-Build Team has previously provided a signed Confidentiality Agreement for an embedded employee who's employer and / or NCDOT Unit Manager have not changed, the Design-Build Team shall 1) indicate on the aforementioned list when the original Confidentiality Agreement was provided to the Design-Build Unit (date and TIP Project), 2) provide a copy of the original signed Confidentiality Agreement, or 3) provide a new signed Confidentiality Agreement. The Design-Build Team shall submit the aforementioned list and Confidentiality Agreements to Mr. Ronald E. Davenport, Jr., P.E., State Contract Officer, within ten business days of the issuance of the Industry Draft RFP, and provide updated lists and Confidentiality Agreements, as appropriate, throughout the project procurement / duration.

Failure to comply with the terms stated above in this section may be grounds for termination of this contract and / or not being considered for selection of work on future contracts for a period of one year.

SUBMITTAL OF TECHNICAL AND PRICE PROPOSALS

Technical and / or Price Proposals that do not adhere to all the requirements noted below may be considered non-responsive and may result in the Department not considering the Design-Build Team for award of the contract or reading their Price Proposal publicly.

TECHNICAL PROPOSAL - Hard Copies

Technical Proposals will be accepted until **4:00 p.m. Local Time on Wednesday, March 27, 2019**, at the office of the State Contract Officer:

Mr. Ronald E. Davenport, Jr., PE
 Contract Standards and Development
 1020 Birch Ridge Drive
 Century Center Complex - Building B
 Raleigh, NC 27610

No Technical Proposals will be accepted after the time specified.

Hard copies of the Technical Proposal shall be submitted in a sealed package. The outer wrapping shall clearly indicate the following information:

Technical Proposal – Hard Copies
 Submitted By: (Design-Build Team's Name)
 Design-Build Team Address
 Contract Number C204196
 TIP Number R-2721A
 Wake County

Triangle Expressway from east of NC 55 Bypass to east of Pierce Olive Rd

If delivered by mail, the sealed package shall be placed in another sealed package and the outer envelope addressed to the Contract Officer as stated in the Request for Proposals. The outer package shall also bear the statement "Technical Proposal for the Design-Build of State Highway Contract No. C204196".

Reference the *Submittal of Quantities, Fuel Base Index Price and Opt-Out Option* Project Special Provision for additional requirements that are concurrent with the submission of the Technical Proposal.

Technical Proposal Requirements

12 Copies
 8 ½ inch by 11 inch pages
 An 11"x 17" sheet is permitted to present a team organization chart
 No fold out sheets allowed – 24 inch by 36 inch fold out sheets shall only be allowed to present interchange plans in the 11 inch by 17 inch plan sheets
 Printed on one side only
 Double-spaced
 Font size 12

Within embedded tables, charts, and graphics only, minimal font size 10 is permissible

Excluding the introductory letter to Mr. Ronald E. Davenport, Jr., P.E. (two-page maximum length) and the 11 inch by 17 inch appropriate plan sheets, the maximum number of allowable pages shall be 40 pages.

The aforementioned introductory letter to Mr. Ronald E. Davenport, Jr., PE shall include a statement acknowledging that the NCTA may destroy all Technical Proposals not retained by the Department, **or** a statement that the NCTA should return all Technical Proposals not retained by the Department.

Project team members, identified in the Statement of Qualifications, shall not be modified in the Technical Proposal without written approval of the NCTA. Any such request should be sent to the attention of Mr. Ronald E. Davenport, Jr., PE, at the address below:

NCDOT- Contract Standards and Development
Century Center Complex - Building B
1020 Birch Ridge Drive
Raleigh, NC 27610

TECHNICAL PROPOSAL - Electronic Copy

An electronic copy of the Technical Proposal shall be submitted in a sealed package. The electronic copy shall be created by converting the original MicroStation / GeoPak files into PDF format. The electronic copy shall be scaled to reproduce to the appropriate page format, as defined above. The outer wrapping shall clearly indicate the following information:

Technical Proposal – Electronic Copy
Submitted By: (Design-Build Team's Name)
Design-Build Team Address
Contract Number C204196
TIP Number R-2721A
Wake County

Triangle Expressway from east of NC 55 Bypass to east of Pierce Olive Rd

If delivered by mail, the sealed envelope shall be placed in another sealed envelope and the outer envelope addressed to the Contract Officer as stated in the Request for Proposals. The outer envelope shall also bear the statement "Technical Proposal for the Design-Build of State Highway Contract No. C204196".

PRICE PROPOSAL

Price Proposals will be accepted until **4:00 p.m. Local Time on ~~Monday~~Friday, April 85, 2019** at the office of the State Contract Officer:

Mr. Ronald E. Davenport, Jr., PE
Contract Standards and Development
1020 Birch Ridge Drive
Century Center Complex - Building B
Raleigh, NC 27610

No Price Proposals will be accepted after the time specified.

Price Proposals shall be submitted in a sealed package. The outer wrapping shall clearly indicate the following information:

Price Proposal
Submitted by (Design-Build Team's Name)
Design-Build Team Address
Contract Number C204196
TIP Number R-2721A
Wake County

Triangle Expressway from east of NC 55 Bypass to east of Pierce Olive Rd

The Price Proposal shall be submitted by returning the Request for Proposals with the item sheets completed, and all required signatures and bonds. Failure to execute the required documents may render the Price Proposal non-responsive.

If delivered by mail, the sealed envelope shall be placed in another sealed envelope and the outer envelope addressed to the Contract Officer as stated in the Request for Proposals. The outer envelope shall also bear the statement "Price Proposal for the Design-Build of State Highway Contract No. C204196".

EVALUATIONS

Decisions based on cost alone will not establish the design standards for the project. Technical Proposals shall address the technical elements of the design and construction of the project. The Technical Review Committee will consider the understanding of the project, the anticipated problems and the solutions to those problems, in addition to other evaluation criteria identified herein.

The Design-Build Team's Technical Proposal shall be developed using narratives, tables, charts, plots, drawings and sketches as appropriate. The purpose of the Technical Proposal is to document the Design-Build Team's understanding of the project, demonstrate the Design-Build Team's capabilities to complete the project, document their selection of appropriate design criteria and state their approach and schedule for completing all design and construction activities.

The review of design plans by the Department and NCTA is not intended to reflect a reviewer's personal preferences, but rather to ensure that all contract requirements are met, sound engineering judgment is exercised by the Design-Build Team, and that the Design-Build Team adheres to all referenced documents, including but not limited to, design standards, codes, memos and manuals. As such, the Award of the Design-Build contract does not in any way imply that the NCDOT or NCTA accepts the details of the Technical Proposal submitted by the Design-Build Team.

The NCTA reserves the right to engage personnel from private engineering firms under contract with the NCTA to assist in the review of design submittals; however all resulting comments of such reviews will be reviewed by the NCTA prior to conveyance to the Design-Build Team.

The Technical Proposal will be evaluated in each of the following major categories:

EVALUATION FACTORS	POINTS
1. Management	7
2. Responsiveness to Request for Proposal	45
3. Long Term Maintenance	5
4. Schedule and Milestones	25
5. Innovation	5
6. Maintenance of Traffic and Safety Plan	10
7. Oral Interview	3

TECHNICAL PROPOSAL EVALUATION CRITERIA

1. Management – 7 points

Provide a comprehensive Organizational Chart that identifies the design, quality and construction management, and the relationships with subconsultants / subcontractors. The Chart shall identify all firms and personnel changes (additions, substitutions, deletions) to the Design-Build Team since submittal of the Statement of Qualifications.

Design-Build Team Management

- Describe the Design-Build Team’s concept of design management and identify key positions and subordinate organizational units.
- Describe how the various design disciplines will be coordinated, including how designs developed by different firms and offices will be integrated / consistent.
- Describe how design personnel will interface with the construction personnel.
- Describe the specific pre-construction items of work that will be performed by Small Professional Services Firms and Certified DBE firms.
- Identify and provide a brief narrative for the Design-Build Team’s Schedule Representative. A resume is optional and, if provided, can be included in Volume 2 of the Technical Proposal.

Quality Management

- Describe how the Design-Build Team will comply with the design and construction quality control requirements. Specifically, include a narrative that describes the Design-Build Team’s understanding of the Department’s quality control philosophy and how the Design-Build Team will implement it for this project.
- Describe any significant design and/or construction quality control issues experienced on NCDOT projects in the last ten years and how those issues will be addressed for this project.

Construction Management

- Describe the Design-Build Team's concept of the project construction management organization and how it interrelates with the other elements of the Design-Build Team's organization for the project.
- Provide a brief narrative of the Design-Build Team's proposed plan for performing construction. This description shall include at least the following:
 - Indicate if, and how, the Design-Build Team intends to divide the project into work segments to enable optimum construction performance.
 - Describe the work categories that the Design-Build Team anticipates will be performed by the Design-Build Team's own direct labor force and those categories that will be performed by subcontractors.
 - Describe the Design-Build Team's plans and procedures to insure timely deliveries of materials to achieve the project schedule.
 - Describe the Design-Build Team's approach to site access, borrow sites, and material staging.
 - Describe the roller compacted concrete subcontractor's qualifications, if applicable.
 - Describe the approach that will be used to provide the NCDOT and the public with construction related information.
- Include a statement in this section if the Design-Build Team has elected to forego the adjustment afforded by the *Price Proposal Index* Project Special Provision. Such election will have no bearing on the evaluation of the Technical Proposal.

2. Responsiveness to RFP – 45 points

Natural Environmental Responsibility

- Describe the Design-Build Team's approach to addressing environmental concerns within the project boundaries.
- Identify efforts to minimize impacts on wetlands, streams, riparian buffers and other environmentally sensitive areas. Describe any temporary impacts and associated minimization approaches.
- Describe the Design-Build Team's anticipated design or construction details that are anticipated to require a permit modification.
- Identify methods of construction in wetlands, streams and buffers.
- Describe all project / construction related Notice of Violations (NOVs) received by any team member within the last five years on projects in the United States and the disposition of each listed NOV.
- Describe the Design-Build Team's approach to Sedimentation and Erosion Control for the project.
- Provide a narrative overview of the Design-Build Team's Vegetation Management Procedure.

Design Features

- Show plan view of design concepts with key elements noted.
- Identify preliminary horizontal and vertical alignments of all roadway elements.
- Show mainline typical sections.
- Show other proposed deviations to the preliminary design provided by the Department.
- Identify drainage modifications and designs to be implemented.
- Identify all hydraulically deficient storm drainage systems and the proposed mitigation on the plans.
- Provide a brief summary of the hydroplaning risk assessment.
- Provide a *Box Culverts and Cross Pipes Hydraulic Deficiency Assessment and Proposed Mitigation Table* that contains the box culvert and cross pipe attributes noted in the Hydraulics Scope of Work.
- Provide a *Box Culverts and Cross Pipes Hydraulic Assessment Table* that contains the box culvert and cross pipe attributes noted in the *Hydraulics Scope of Work*.
- Discuss the extent and limits of the rise in water elevation in the floodplain(s), identify potentially impacted insurable structures, specify areas anticipated to require additional surveys and estimate the anticipated additional right of way impacts outside the project construction limits.
- Identify the appropriate design criteria for each feature, if not provided herein.
- Identify all bridge types to be constructed, including any special design features or construction techniques needed.
- Specify the mainline (and shoulders) pavement Alternate chosen. The pavement Alternate chosen for the mainline will not be a part of the Technical Proposal evaluation and the selection thereof will not impact the Technical Scores; although an alternate pavement design, as approved as an ATC, may be considered in the evaluation.
- Specify the base option chosen (ABC or asphalt) for all -Y- Lines.
- If applicable, specify where all underlying longitudinal joints will be located and demonstrate how the underlying longitudinal joint location will minimize reflective cracking.
- Discuss the anticipated subgrade stabilization and the application of geotextile along the mainline.
- Identify any deviations, including proposed design exceptions, from the established design criteria that will be utilized. Explain why the deviation is necessary.
- Describe how the proposed design for drainage, lighting, ITS, conduit, etc. accommodates the future median widening as described in the *Roadway Scope of Work*.
- Describe any geotechnical investigations to be performed by the Design-Build Team and note any deviations to NCDOT requirements for subsurface investigations noted in the Geotechnical Scope of Work.
- Provide a preliminary signing concept.
- Describe how utility conflicts will be addressed and any special utility design considerations. Describe how the Design-Build Team's design and construction methods minimize the Department's utility relocation costs.

- Describe how the proposed design will affect or accommodate the planned work for adjustments to Colonial Pipeline facilities.
- Describe how the design will affect the Department's right of way costs and discuss how the priorities will be established for acquiring right of way.
- Identify types of any retaining walls and / or sound barrier walls, if applicable.

Aesthetic Design Features

- Identify all aesthetic features included in the design including those categories identified in the Aesthetics Design Scope of Work as well as any other special aesthetics commitments.

Right of Way

- Provide a list of right of way acquisition priorities as more fully described in the *Right of Way Scope of Work*. While this list shall be submitted as part of the Technical Proposal, the contents of this list will not be a part of the evaluation of the Technical Proposal.

3. Long Term Maintenance – 5 points

- Describe any special materials, not referenced elsewhere in this RFP, incorporated into the project that would result in long term reduction in maintenance.
- Describe any special designs or construction methods that would reduce future maintenance costs to the NCTA.
- Estimate a minimum ten-year cost saving resulting from incorporation of these special materials, design or construction methods into the project.

4. Schedule and Milestones – 25 points

- Provide a detailed schedule for the project including both design and construction activities. The schedule shall also show the sequence and continuity of operations.
- Indicate how the Design-Build Team will maintain the project schedule if the right of way acquisition process and/or utility relocations are delayed.
- Identify any self-imposed liquidated damages and associated Intermediate Contract Time(s), if applicable.
- The schedule shall also include the Design-Build Team's final completion date and, if proposed, their substantial completion date. **These dates shall be clearly indicated on the Project Schedule and labeled "Final Completion Date" and "Substantial Completion Date"**.
- Due to the potential for limited right of way availability, and to create an equitable bidding environment, the detailed schedule shall not show construction (other than utility relocations) beginning prior to November 1, 2019.
- It is the goal of the NCTA to be able to open the extension of the Triangle Expressway all the way to I-40 at one time rather than in segments. As such, proposed completion dates on one of the R-2721A, R-2721B, or R-2828 contracts that is far earlier than that of the other contracts has less benefit to the NCTA. The

Substantial Completion Date for the R-2828 contract is October 24, 2022. The Final Completion Date for the R-2828 contract is November 24, 2022. In the event a Design-Build Team for R-2721A proposes dates earlier than these dates, the value to the NCTA of the earlier proposed R-2721A schedule diminishes the more that schedule precedes the R-2828 schedule, and will be evaluated accordingly.

5. Innovation – 5 points

- Identify any aspects of the design or construction elements that the Design-Build Team considers innovative. Include a description of alternatives that were considered whether implemented or not.

6. Maintenance of Traffic and Safety Plan – 10 points

Maintenance of Traffic

- Provide a Transportation Management Phasing Concept (TMPC).
- Describe any traffic control requirements that will be used for each construction phase.
- Describe how traffic will be maintained as appropriate and describe the Design-Build Team's understanding of any time restrictions noted in the RFP.
- Specifically describe how business, school and residential access will be maintained, if applicable.
- Address how hauling will be conducted, including but not limited to, hauling of materials to and from the site and hauling of materials within NCDOT right of way.
- If a temporary portable barrier system will be utilized, provide the type and why it is needed.
- Include all proposed road closures, detour routes, justifications and durations.
- Address where and how law enforcement officers will be used.
- Identify a Traffic Control Supervisor and briefly describe their qualifications for this role.

Safety Plan

- Describe the safety considerations specific to the project.
- Discuss the Design-Build Team's overall approach to safety.
- Describe any proposed improvements that will be made prior to or during construction that will enhance the safety of the work force and / or travelling public both during and after the project construction.

7. Oral Interview – 3 points

- The Design-Build Team's Project Management Team shall present a brief introduction of the project team and design / construction approach.
- Introductory comments shall be held to no more than 25 minutes.
- The Department will use this interview to ask specific questions about the Design-Build Team's Technical Proposal, background, philosophies and project approach.

- Presentation, questions, and answers shall not exceed 90 minutes. No more than twelve people from the Design-Build Team may attend.

The Department will use the information presented in the oral interview to assist in the Technical Proposal evaluation.

Additional Warranty and / or Guarantee

- **The Extra Credit for this project shall be a Maximum of 3 Points.**

A guarantee, as outlined in the *Three-Year Guarantee* Project Special Provision found elsewhere in this RFP, is required for this project. However, the Design-Build Team may provide additional warranties and / or guarantees at their discretion. The Design-Build Team may be awarded additional points as “extra credit” to be added to the Technical Score.

The Design-Build Team may provide a time extension of the requirements of the Three-Year Guarantee for any or all of the elements of the Project; provided however the Design-Build Team commits in their Technical Proposal to extend the term of the Warranty Bond as applicable.

If an additional time extension of the guarantee is offered, the Design-Build Team shall indicate in the Technical Proposal any deviations from the Three-Year Guarantee Provision that would apply to the time extension. Prior to the first partial payment, the Design-Build Team shall submit a document that provides additional guarantee specifics in sufficient detail that allows the document to be made a part of the contract through supplemental agreement.

No direct payment will be made for additional guarantees. Payment will be considered incidental to the lump sum price for the contract.

SELECTION PROCEDURE

There will be a Technical Review Committee (TRC) composed of five or more senior personnel from involved engineering groups that will evaluate the Technical Proposal on the basis of the criteria provided in the Request for Proposals.

The NCTA reserves the right to engage personnel from private engineering firms under contract with the NCTA to assist in the review of Technical Proposals and these personnel may input to the Technical Review Committee. However, the Technical Review Committee will be employees of the NCDOT or NCTA.

The selection of a Design-Build Team will involve both technical quality and price. The Technical Proposals will be presented to the TRC for evaluation. The TRC shall first determine whether the proposals are responsive to the requirements of the Request for Proposals. The Department reserves the right to ask for clarification on any item in the Technical Proposal. A written response to this request for clarification shall be provided to the Department prior to the opening of the Price Proposals. The contents of the written response may affect the Technical Review Committee’s determination of the Technical Proposal’s responsiveness and / or the overall evaluation of the Technical Proposal. If any commitments or clarifications provided in

the written response conflict with the contents of the Technical Proposal, the contents of the written response will govern and be incorporated into the contract.

Each responsive Technical Proposal shall be evaluated based on the rating criteria provided in the Request for Proposals. The TRC will submit an overall consensus Technical Proposal score for each Design-Build Team to the State Contract Officer.

Quality Credit Evaluation Factors for Technical Proposals

Management	7
Responsiveness to Request for Proposal	45
Long Term Maintenance	5
Schedule and Milestones	25
Innovation	5
Maintenance of Traffic and Safety Plan	10
Oral Interview	3
Maximum Score	100

The State Contract Officer will use a table based on the maximum quality credit percentage to assign a Quality Credit Percentage to each proposal based on the proposal's overall Technical Score. The maximum quality credit percentage for this project will be **20%**. The Technical Review Committee may elect to assign point values to the nearest one-tenth of a point (e.g. 90.3). In this event, the Quality Credit Percentage will be determined by linearly interpolating within the table entitled "Quality Credit Percentage for Technical Proposals".

Quality Credit Percentage for Technical Proposals

Technical Score	Quality Credit (%)	Technical Score	Quality Credit (%)
100	20.00	84	9.33
99	19.33	83	8.67
98	18.67	82	8.00
97	18.00	81	7.33
96	17.33	80	6.67
95	16.67	79	6.00
94	16.00	78	5.33
93	15.33	77	4.67
92	14.67	76	4.00
91	14.00	75	3.33
90	13.33	74	2.67
89	12.67	73	2.00
88	12.00	72	1.33
87	11.33	71	0.67
86	10.67	70	0.00
85	10.00		

The maximum Technical Score, including any extra credit given for warranties or guarantees, shall not exceed 100 points in determining the Quality Credit percentage.

If any of the Technical Proposals are considered non-responsive, the State Contract Officer will notify those Design-Build Teams of that fact.

The State Contract Officer shall publicly open the sealed Price Proposals and multiply each Design-Build Team's Price Proposal by the Quality Credit Percentage earned by the Design-Build Team's Technical Proposal to obtain the Quality Value of each Design-Build Team's Technical Proposal. The Quality Value will then be subtracted from each Design-Build Team's Price Proposal to obtain an Adjusted Price based upon Price and Quality combined. Unless all Proposals are rejected or the Department elects to proceed with the Best and Final Offer process, the Department will recommend to the State Transportation Board that the Design-Build Team having the lowest adjusted price be awarded the contract. The cost of the Design-Build contract will be the amount received as the Price Proposal.

The following table shows an example of the calculations involved in this process.

An Example of Calculating Quality Adjusted Price Ranking

Proposal	Technical Score	Quality Credit (%)	Price Proposal (\$)	Quality Value (\$)	Adjusted Price (\$)
A	95	16.67	3,000,000	500,100	2,499,900
B	90	13.33	2,900,000	386,570	2,513,430
C *	90	13.33	2,800,000	373,240	2,426,760
D	80	6.67	2,700,000	180,090	2,519,910
E	70	0.00	2,600,000	0	2,600,000
* Successful Design-Build Team – Contract Cost \$2,800,000					

Opening of Price Proposals

Prior to opening the Price Proposals, the State Contract Officer will provide to each Design-Build Team their Technical Score in a sealed envelope. The sealed envelope will contain that Team's score only.

At the time and date specified, the State Contract Officer will open the Price Proposals and calculate the percentage difference between the Price Proposals submitted and the Engineer's Estimate.

Should all of the Price Proposals be within an acceptable range or below the Engineer's Estimate, the State Contract Officer will proceed to calculate the quality credit and publicly read the Price Proposal, Technical Score and Adjusted Price as outlined in the selection procedure above.

Should one or more of the Price Proposals be within an acceptable range or below the Engineer's Estimate and the remaining Price Proposals exceed an acceptable range of the Engineer's Estimate, the State Contract Officer will go to a separate location to calculate the quality credit and determine if the Design-Build Team with the lowest Adjusted Price is within an acceptable range of the Engineer's Estimate. Should the Price Proposal of the Design-Build Team with the lowest Adjusted Price be within an acceptable range of the Engineer's Estimate or below the Engineer's Estimate the State Contract Officer will proceed to publicly read the Price Proposals, Technical Scores and Adjusted Prices. Should the Price Proposal of the Design-Build Team with

the lowest Adjusted Price exceed an acceptable range of the Engineer's Estimate, the State Contract Officer will publicly read the Price Proposals only and the Department will then determine whether to proceed to request a Best and Final Offer (BAFO) as outlined below.

Should all Price Proposals submitted exceed an acceptable range of the Engineer's Estimate the State Contract Officer will publicly read the Price Proposals only. The Department will then determine whether to proceed to request a Best and Final Offer (BAFO) as outlined below.

In the event that the Department elects to not proceed with a Best and Final Offer (BAFO), then the State Contract Officer will schedule a date and time to publicly reiterate all Price Proposals, and read all Technical Scores and Adjusted Prices.

Provided the Department elects to proceed to request a Best and Final Offer (BAFO), at the date and time specified, the State Contract Officer will open the Best and Final Offer Price Proposals and proceed to publicly read all Price Proposals, Technical Scores and Adjusted Prices.

Best and Final Offer

In the event initial Price Proposals exceed an acceptable range of the Engineer's Estimate or if the Department feels it is necessary for any reason the Department may choose to make amendments to the details of the RFP and request a Best and Final Offer from all of the previously short-listed teams. Alternately, the Department may choose to redistribute to the short-listed Design-Build Teams another RFP for the project with no amendments to the RFP scope.

After receipt of the redistributed RFP, the Design-Build Team has the option of changing their Technical Proposal details. If the Design-Build Team changes any component of the Technical Proposal, the TRC will review those amended components of the Technical Proposal and reevaluate the scores accordingly. The Design-Build Team shall highlight the changes to bring them to the Department's attention. A revised total score will be calculated, if appropriate, based on these amendments to the Technical Proposal.

Additional oral interviews will not be held. The Design-Build Teams shall submit both a revised Price Proposal and a revised Technical Proposal (if applicable) at the time, place and date specified in the redistributed RFP. A revised Quality Credit (if required) and Adjusted Price will be determined. This will constitute the Design-Build Team's Best and Final Offer. Award of the project may be made to the Design-Build Team with the lowest Adjusted Price on this Best and Final Offer.

Stipend

A stipulated fee of **\$125,000.00** will be awarded to each short-listed Design-Build Team that provides a responsive, but unsuccessful, Design-Build Proposal. If a contract award is not made, all short-listed Design-Build Teams that provide a responsive Design-Build Proposal shall receive the stipulated fee. Once award is made, or a decision is made not to award, unsuccessful Design-Build Teams can apply for the stipulated fee by notifying the State Contract Officer in writing and providing an original invoice within 60 days of Award. If the Design-Build Team accepts the stipulated fee, the Department reserves the right to use any ideas or information

contained in the Design-Build Proposal and / or Alternative Technical Concepts, whether incorporated into the Design-Build Proposal or not, in connection with any contract awarded for the project, or in connection with any subsequent procurement, with no obligation to pay additional compensation to the unsuccessful Design-Build Team. The stipulated fee shall be paid to eligible Design-Build Teams within ninety days after the award of the contract or the decision not to award. Unsuccessful Design-Build Teams may elect to refuse payment of the stipulated fee and retain any rights to its Design-Build Proposal and the ideas and information contained therein.

In the event that the Department suspends or discontinues the procurement process prior to the Design-Build Proposal submittal date current at the time of the suspension, no stipulated fee will be paid, unless otherwise approved by the Secretary of Transportation and the North Carolina Turnpike Authority Board.

ROADWAY SCOPE OF WORK~~(12-14-18)~~ 1-10-19

Throughout this RFP, references to the "Roadway Plans" denote the R-2721 Roadway Right of Way Plans most recently provided by the Department.

1. MAINLINE REQUIREMENTS**1.1. Mainline Project Limits, Design Criteria, and Typical Section**

- 1.1.1. The Design-Build Team shall design and construct a six-lane divided facility for the extension of the Triangle Expressway (NC 540) from the existing Triangle Expressway east of Veridea Parkway to Station 240+00 -L- (R-2721B tie point), east of SR 1389 (Pierce-Olive Road) in Wake County.
- 1.1.2. Unless noted otherwise elsewhere in this RFP, the Design-Build Team shall design and construct the -L- Line (mainline) providing the same or better access, widening, improvements and traffic measures of effectiveness, in the Department's sole discretion, included in the Roadway Plans provided by the Department.
- 1.1.3. The design and construction of this project shall accommodate one future additional median lane in each direction along the new location portion of the project corridor to the extent that items such as gantries and bridges and, to the greatest extent practicable, conduit and lighting, do not require relocation or replacement at the time that this future improvement is made. To the greatest extent practicable, drainage structures in the median shall be located so that horizontal adjustment to these drainage features is not required during future widening. The Design-Build Team shall discuss in the Technical Proposal all conduit, lighting, ITS infrastructure, gantries, and drainage that will require adjustment when the future median lanes are constructed. The Design-Build Team shall not waste or place any unsuitable materials in the median.
- 1.1.4. The mainline shall be designed and constructed to meet a 75-mph design speed for a rolling rural freeway designed to interstate standards. The mainline shall be designed and constructed in accordance with the AASHTO *A Policy on Geometric Design of Highways and Streets*, Table 3-10b ($e_{\max} = 8\%$). The Design-Build Team shall provide all other design criteria in the Technical Proposal.
- 1.1.5. The Design-Build Team shall design and construct 12-foot mainline travel lanes.
- 1.1.6. The Design-Build Team shall design and construct minimum 14-foot outside and median shoulders (12-foot useable shoulder width plus two feet), 12-foot of which shall be full depth paved shoulders, including along all acceleration, deceleration and auxiliary lanes, and ramps/loops to the back of the gore (12-foot paved width). In cases where sound barrier walls are adjacent to the shoulder, the minimum shoulder width shall be 18-feet, all of which shall be full depth paved.
- 1.1.7. The Design-Build Team shall provide milled rumble strips along the mainline outside and median paved shoulders, including ramp and loop terminals, and acceleration, deceleration

and auxiliary lanes, in accordance with the NCDOT *Roadway Standard Drawings*. The edge of paved shoulder noted in Roadway Standard Drawing No. 665.01 or No. 720.01 shall be the edge of paved shoulder, as applicable.

- 1.1.8. The mainline median width shall be a minimum of 70 feet throughout the entire project which will accommodate future median widening. [For median pier protection, NCDOT Standard Drawing 862.01 shall be used.](#)
- 1.1.9. The mainline grade point shall be located at the median edge of the travel lane. In a normal crown section, the mainline two exterior travel lanes shall slope towards the outside at a 0.02 cross slope and the one interior travel lane and paved median shoulders shall slope towards the median at a 0.02 cross slope.
- 1.1.10. The minimum mainline right of way width shall be 350 feet unless otherwise approved by the NCTA. NCTA may grant exceptions to the minimum 350-foot width in localized areas to avoid environmentally sensitive areas or other such constraints.
- 1.1.11. Design exceptions will not be allowed for the -L- Line, including all ramps and loops.
- 1.1.12. Unless noted otherwise elsewhere in this RFP, the Design-Build Team shall design and construct all lane drops from the outside travel way.

1.2. Mainline Project Termini Coordination

- 1.2.1. At the R-2721B tie point, the mainline final horizontal alignment/location and the final vertical alignment grade and elevation shall be in close conformity with the Roadway Plans and shall be coordinated with the R-2721B Design-Build Team through the NCTA.
- 1.2.2. The Design-Build Team shall coordinate with the Project R-2721B Design-Build Team to ensure accurate sound barrier walls, hydrology, capacity, horizontal and vertical ties that adhere to the design criteria and Design Noise Reports. The Design-Build Team shall not make any design or construction revisions that impact the design or construction of Project R-2721B without prior written approval from the NCTA. The aforementioned prior written approval shall occur through coordination and/or submittals to the NCTA after Award.

2. INTERCHANGES

2.1. NC 55 Bypass Interchange

- 2.1.1. The Design-Build Team shall design and construct the modifications to the existing NC 55 Bypass interchange at the Triangle Expressway. The interchange modifications include:
 - Modifying or reconstructing the existing Loop C acceleration lane and loop to eliminate the sharp right turn currently required to use this loop from westbound NC 540 to NC 55 Bypass, Loop C as identified on the public hearing maps, providing a minimum radius to accommodate a WB-67 design vehicle.
 - Modifying or constructing Ramp D and -Y1RPC- to accommodate the Loop C revision.

- Reconstructing the existing Loop B as identified on the public hearing maps.
 - Designing and constructing the Ramp D acceleration lane along NC 540 as shown in the Roadway Plans.
 - Mill 1.5 inches of existing asphalt pavement and pave with 1.5 inches of S9.5C on Ramp A and Ramp D within the limits of the existing asphalt pavement to NC 55 Bypass.
- 2.1.2. The interchange configuration proposed by the Design-Build Team shall meet or exceed the operational characteristics for all movements of the interchange contained in the Roadway Plans in the Department's sole discretion.

2.2. Holly Springs Road (SR 1152) Interchange

- 2.2.1. The Design-Build Team shall design and construct a Diverging Diamond Interchange (DDI) between the Triangle Expressway and Holly Springs Road (SR 1152).
- 2.2.2. The Design-Build Team shall design and construct the DDI in accordance with the requirements noted below:
- Between and through the DDI crossovers, the Design-Build Team shall design and construct lane widths that accommodate a WB-67; however, the minimum lane width through the DDI crossovers shall be 15 feet. All approach / departure lanes to / from the crossovers shall be tapered to the crossover lane-width prior to entering / after exiting the curve approaching / departing the crossover. While the design speed for Holly Springs Road is 50 mph, the design speed for the crossovers shall be a minimum of 25 mph.
 - The Design-Build Team shall design and construct lane widths for all spurs (right and left turn movements from / to the ramps) that accommodate a WB-67. All approach / departure ramp lanes to / from the spurs shall be tapered to the spur lane width prior to entering / after exiting the spur. Regardless of the spur lane width, all spur alignments shall be located 15 feet from the outside edge of travel lane. Lane widths transition from 15 feet to 12 feet across the bridge.
 - The four ramp channelization islands shall be raised grass islands bordered with 2'-6" curb and gutter. Within the aforementioned ramp channelization islands, the Design-Build Team shall provide a minimum five-foot wide pedestrian accommodation that accesses the pedestrian median accommodation noted below
 - Between the DDI crossovers, the Design-Build Team shall provide a minimum ten-foot wide pedestrian accommodation within the -Y- Line median. Along both sides of the aforementioned ten-foot pedestrian accommodation, the Design-Build Team shall provide a minimum 1' barrier that extends a minimum of 42" above the walking surface. The barrier shall meet AASHTO Manual for Assessing Safety Hardware, TL-2 crash test requirements and terminate with a ten-foot taper that reduces the barrier height to 2'-3". Excluding within the aforementioned ten-foot taper, the handrail shall be installed in accordance with the 10-30-2013 Proposed Pedestrian Safety Rail Detail provided by the Department.

- The curves approaching / departing the crossovers shall slope from the median to the outside at a 0.02 cross slope.

2.3. Modifications to NC 55 Bypass and Holly Springs Road (SR 1152) Interchanges

- 2.3.1. In addition to the requirements of this Scope of Work, any modifications proposed at each of these two interchanges shall not result in an increase in the total amount of right of way or jurisdictional impacts beyond that required for the applicable interchange shown in the Roadway Plans. Permanent utility easements are not considered additional right of way for the purposes of this section.
- 2.3.2. The use of a DDI other than at Holly Springs Road, shall only be permitted through an approved Alternative Technical Concept. In addition, the elimination of the DDI at Holly Springs Road shall only be permitted through an approved Alternative Technical Concept.
- 2.3.3. Roundabouts at interchange ramp terminals shall only be permitted through an approved Alternative Technical Concept.
- 2.3.4. Elimination of any ramps or loops at the NC 55 Bypass Interchange or the Holly Springs Road Interchange will only be permitted through an approved Alternative Technical Concept.

3. RAMPS AND LOOPS

3.1. General

Unless otherwise noted in this RFP, the Design-Build Team shall design and construct ramps and loops providing the same or better level of access, capacity, improvements, number of lanes, design speed, and traffic measures of effectiveness in the NCTA's sole discretion, included in the Roadway Plans.

3.2. Ramps

The Design-Build Team shall design and construct one-lane ramps that provide a minimum 16-foot lane width. The Design-Build Team shall design and construct two-lane ramps that provide minimum 12-foot lanes. All ramps shall have minimum 14-foot outside shoulders, a minimum four-foot of which shall be full depth paved shoulders and minimum 12-foot inside shoulders, a minimum of four-foot of which shall be full depth paved shoulder. In areas where sound barrier walls are adjacent to the ramp shoulder, the minimum shoulder width shall be 14-feet, all of which shall be full depth paved. The minimum ramp design speed shall be in accordance with the *NCDOT Roadway Design Manual*.

3.3. Loops

The Design-Build Team shall design and construct one-lane loop ramps that provide a minimum 18-foot lane width. All loops shall have minimum 12-foot outside shoulder, a minimum four-foot of which shall be full depth paved shoulder. All loops shall have 2'-6" curb and gutter along the

inside edge of pavement, with a 14-foot berm. The minimum loop design speed shall be 30 mph with a minimum 230-foot radius except for -Y1LPB- at NC 55 Bypass which shall have a minimum 214-foot radius.

4. -Y- LINE REQUIREMENTS

4.1. General

- 4.1.1. Unless noted otherwise elsewhere in this RFP, the Design-Build Team shall design and construct -Y- Lines, service roads, and cul-de-sacs / turnarounds providing the same or better access, widening, improvements and traffic measures of effectiveness, in the NCTA's sole discretion, included in the Roadway Plans provided by the NCTA.
- 4.1.2. The limits of -Y- Line construction shall be of sufficient length to tie to existing based upon the current NCDOT guidelines and standards.
- 4.1.3. The Roadway Plans accommodate the 2040 Capital Area Metropolitan Planning Organization - Metropolitan Transportation Plan. The Design-Build Team shall review the 2045 Capital Area Metropolitan Planning Organization - Metropolitan Transportation Plan and ensure that the design and construction of this project accommodates this 2045 plan in regards to the number of travel lanes to be provided with the project or accommodated through the project area for future construction by others.
- 4.1.4. The Design-Build Team shall design and construct all -Y- Lines such that the through movement is not required to change lanes throughout the project limits.
- 4.1.5. NCDOT prefers not to have design exceptions for the -Y- Lines and service roads. No design exceptions will be required to tie the proposed profile to the existing to match or exceed the existing conditions as shown in the Roadway Plans. If the Design-Build Team anticipates any design exceptions, they shall be clearly noted in the Technical Proposal. Prior to requesting / incorporating a design exception into the Final Plans, the Design-Build Team must obtain prior conceptual approval from NCTA. If conceptual approval is obtained, the Design-Build Team shall be responsible for the development and approval of all design exceptions.
- 4.1.6. The Design-Build Team shall be responsible for the evaluation of the algebraic difference in rates of cross slope (roll-over) between existing shoulders and roadways and the associated suitability for carrying traffic during construction, if necessary. In the event that the roll-over is found to be unacceptable for the proposed temporary traffic patterns, the Design-Build Team shall be responsible for providing cross slopes that meet design standards and eliminate roll-over concerns.

4.2. NC 55 Bypass

For NC 55 Bypass under Triangle Expressway, the Design-Build Team shall design and construct an additional southbound lane by widening to the inside within the limits of the interchange for use as a turn lane. NC 55 Bypass is considered an Arterial with a 60-mph design speed.

4.3. E. Williams Street

E. Williams Street is considered a Minor Arterial with a 50-mph design speed. For Triangle Expressway over E. Williams Street, no improvements along E. Williams Street are required except ~~(1)~~:

- (1) to design and construct the Triangle Expressway bridges long enough to satisfy the requirements of the *Structures Scope of Work* ~~and (2)~~;
- ~~(1)~~(2) if the outside edge of pavement on E. Williams Street falls within 12 feet of the bridge abutment, perform paving on that side in accordance with Section 4.2.6 of the Pavement Management Scope of Work and resurface E. Williams Street within the longitudinal limits of that paving ~~;~~ and E. Williams Street is considered a Minor Arterial with a 50 mph design speed.
- (3) to construct a 5'-0" sidewalk within the area that the NC 540 right of way limits intersect with E. Williams Street and connect with the existing sidewalk on the east side of E. Williams Street. Under the bridge, the sidewalk shall be located adjacent to the east bridge abutment and transition to the existing sidewalk.

4.4. Sunset Lake Road (SR 1301) – both locations

For Sunset Lake Road (SR 1301) over Triangle Expressway, the Design-Build Team shall design and construct Sunset Lake Road as a five-lane undivided curb and gutter facility. This five-lane section shall include an 11-foot inside lane and a 14-foot shared outside lane, separated by a 16-foot two-way turn lane. This curb and gutter facility shall include a minimum 10-foot berm with 5-foot sidewalks on both sides. This typical section can vary when transitioning to existing Sunset Lake Road. Sunset Lake Road is considered a Collector Street with a 50 mph design speed.

4.5. Holly Springs Road (SR 1152)

For Holly Springs Road (SR 1152) over Triangle Expressway, the Design-Build Team shall design and construct Holly Springs Road as a 6-lane 23-foot raised median curb and gutter facility. This shall include a 10-foot minimum berm width and 5-foot sidewalks on both sides. The 6-lane facility shall include two-12 foot inside lanes, one 11-foot outside lane and one 5-foot dedicated bicycle lane on each side. This typical section can vary when transitioning to existing Holly Spring Road. Holly Springs Road is considered a Collector with a 50-mph design speed.

4.6. Kildaire Farm Road (SR 1300)

For Kildaire Farm Road (SR 1300), the Design-Build Team shall design and construct a four-lane 23-foot raised median curb and gutter facility as described in the 2045 Capital Area Metropolitan Planning Organization. The four-lane facility shall have 12-foot inside lanes and a 14-foot shared outside lane on both sides. A 5-foot sidewalk shall be provided along the south side of the roadway with 10-foot berms on both sides. This typical section can vary when transitioning to existing Kildare Farm Road. Kildare Farm Road is considered an Arterial with a 50 mph design speed.

4.7. Pierce-Olive Road (SR 1389)

For Pierce Olive Road (SR1389) over Triangle Expressway, the Design-Build Team shall design and construct Pierce Olive Road (SR 1389) with two 12-foot lanes along with minimum eight-foot shoulders. For Triangle Expressway over Pierce Olive Road, no improvements along Pierce Olive Road are required except to design and construct the Triangle Expressway bridges long enough to satisfy the requirements of the *Structures Scope of Work*. Pierce Olive Road is considered a Local road with a 50 mph design speed.

4.8. Intersection Design

4.8.1. The Design-Build Team shall design and construct at-grade intersections with the lane configurations for the 2040 Build Preferred Alternative noted in the July 2017 *Preferred Alternative - Traffic Analysis Technical Memorandum* provided by the Department. At all intersections impacted by the Design-Build Team's design and / or construction, excluding resurfacing, the Design-Build Team shall design and construct turn lanes that adhere to the greater of the following:

- All turn lane lengths, unless otherwise specified, shall adhere to the NCDOT minimum turn lane lengths as defined in the NCDOT *Roadway Design Manual* (Reference Section 9-1, Figure 4). Due to minimal spacing, minimum turn lane lengths at Y5/Y5G, Y5/Shopping Center (Parcel 259), and Y5/Y5D intersections do not meet NCDOT *Roadway Design Manual* requirements and therefore the turn lane lengths shown on the Roadway Plans provided by the NCTA are acceptable.
- All lengths for the turn lanes required by the July 2017 *Preferred Alternative - Traffic Analysis Technical Memorandum* provided by the Department shall adhere to the NCDOT Recommended Treatment for Turn Lanes. These lengths shall be determined by adding the storage length defined in the aforementioned Report and the minimum deceleration length, as defined in the NCDOT *Roadway Design Manual* (Reference Section 9-1, Figure F-4A).
- Right turn lanes / tapers shall be provided in accordance with the NCDOT Right Turn Lane Warrants, as defined in the NCDOT *Roadway Design Manual* (Reference Section 9-1, Figure F-4C).

4.8.2. For all intersection design modifications, the Design-Build Team shall provide a traffic analysis that adheres to the July 1, 2015 NCDOT *Congestion Management Capacity Analysis Guidelines* for the Department's review and acceptance.

4.8.3. At all intersections with restricted movements impacted by the Design-Build Team's design and / or construction methods, excluding resurfacing, the Design-Build Team shall provide five-inch keyed-in concrete monolithic channelization islands.

4.8.4. At all intersections, the Design-Build Team shall not exceed a 0.05 roll-over between the outside edge of travel lane of the primary roadway and the beginning of the proposed grade for the secondary roadway.

- 4.8.5. At all -Y- Line / -Y- Line intersection radius points, including service roads, the minimum -Y- Line pavement width shall be 30 feet.
- 4.8.6. At all intersections, new or existing, that are impacted by the Design-Build Team's design and / or construction methods, excluding resurfacing, the following design vehicles shall be required for all turning movements:
- WB-67 at all ramp / loop intersections with -Y- Lines (For side-by-side turning maneuvers, WB-67 for the outside movement only and SU-30 for inside movement)
 - School bus (S-BUS36) for all service roads and subdivision roads.
 - WB-62 at all other intersections (For side-by-side turning maneuvers, WB-62 for the outside movement only and SU-30 for inside movement)

5. ACCESS

5.1. Access Control

Triangle Expressway is a full control of access facility. The Design-Build Team shall bring to the Design-Build Unit's and NCTA's attention any deviations from the proposed control of access shown on the Right of Way Roadway Plans provided by the Department. The proposed right of way and / or control of access limits may deviate in proximity to cultural, historic, or otherwise protected landmarks, including cemeteries, to eliminate / minimize impacts. Prior to negotiating right of way, easement and / or control of access with property owners, the Department shall accept the Right of Way Plans developed by the Design-Build Team.

5.2. Fence and Driveway

- 5.2.1. Prior to installation, the Design-Build Team shall be responsible for coordinating with, and obtaining approval from, the NCDOT for the control of access fence placement. The Design-Build Team shall be responsible for installation of woven wire control of access fence as noted below:
- Throughout the construction limits, excluding areas that consist solely of pavement marking obliterations / revisions, the Design-Build Team shall remove and dispose of all existing control of access fence, and install new control of access fence.
 - The Design-Build Team shall replace all control of access fence damaged during construction.
 - The Design-Build Team shall install all missing control of access fence.
- 5.2.2. Excluding parcels restricted by Control of Access and undeveloped parcels, the Design-Build Team shall design and construct a minimum of one driveway per parcel. The Design-Build Team shall design and construct all driveways that adhere to the NCDOT Policy on Street and Driveway Access to North Carolina Highways and the minimum requirements

noted below. Excluding the maximum grade requirement, if the NCDOT Policy on Street and Driveway Access to North Carolina Highways and the requirements noted below have conflicting design parameters, the proposed design shall adhere to the aforementioned Policy:

- The Design-Build Team shall provide horizontal and vertical alignments for all driveways that require 100 feet or longer to tie to existing.
- Excluding grades required to tie to existing, the maximum driveway grade shall be 10.0%.
- For shoulder sections, the minimum driveway turnout for residential and commercial properties shall be 16'-0" and 24'-0", respectively, or the existing width, whichever is greater.
- For curb and gutter sections, the minimum driveway turnout for residential and commercial properties shall be 20'-0" and 28'-0", respectively, or the existing width, whichever is greater.

5.2.3. Duke Energy will require a few gates in the controlled access fence to access their facilities. The Design-Build Team shall finalize these locations with Duke Energy and design and install such gates. ~~Known~~Known affected parcels currently are Parcels 24, 51, 52, and 441.

5.3. Service Roads

5.3.1. In accordance with the NCDOT Right of Way Manual, the Design-Build Team shall develop Service Road Studies (which may be a stand-alone document from the May 2017 *Service Road Study* provided by the Department) for all land-locked parcels and / or as required by variations to the Department's design. Service Roads shown in the Department's Preliminary Roadway Plans and Right of Way Plans are addressed in the May 2017 *Service Road Study* provided by the Department. If the aforementioned Service Road Studies by the Design-Build Team indicate that service roads are required that are not shown on the Right of Way Plans provided by the Department, the design and construction costs of the additional service roads shall be as follows:

- If the Design-Build Team demonstrates, to the Department's sole satisfaction, that the additional service road(s) are required for the Department's preliminary design, the service road(s) design and construction, including all associated NEPA requirements, will be paid for as extra work in accordance with Subarticle 104-8(A) of the NCDOT *Standard Specifications for Roads and Structures*.
- If variations to the Department's proposed design and / or construction methods require additional service road(s), the service road(s) design and construction, as well as all associated NEPA requirements, shall be included in the Design-Build Team's lump sum bid for the entire project.

5.3.2. The Design-Build Team shall design and construct all service roads as shown in the Roadway Plans provided by the Department. Service roads added by the Design-Build

Team shall be designed and constructed utilizing a minimum 40 mph design speed using the 0.04 superelevation chart. The Design-Build Team shall design and construct all service roads with two ten-foot lanes, minimum (12-foot lanes desirable) and two-foot minimum shoulders with a Type “B” ditch as per the NCDOT Roadway Design Manual. If a service road serves a single property, it can be designed as a driveway.

- 5.3.3. Unless noted otherwise elsewhere in this RFP, the Design-Build Team shall provide cul-de-sacs / turnarounds on all roads that are dead-ended. The Design-Build Team shall provide the roadway terminus type, cul-de-sac or turnaround, in accordance with the type shown on the Right of Way Plans. At a minimum, all cul-de-sacs / turnarounds shall accommodate an S-BUS-36 school bus design vehicle.

6. FINAL DESIGN REPORT AND SOUND BARRIER WALLS

6.1. Final Design Report

- 6.1.1. The Department will provide a Final Design Noise Report based on the Roadway Plans. The Design-Build Team shall reevaluate the entire R-2721A project, post Award, and develop an amended Final Design Noise Report (DNR) based on the plans developed by the Design-Build Team.
- 6.1.2. The amendment to the Final DNR shall be developed in accordance with the NCDOT 2016 *Traffic Noise Policy* and NCDOT 2016 *Traffic Noise Manual*, as amended, and be reviewed and approved by NCDOT.
- 6.1.3. Prequalification under Discipline Code 441 shall be required for the firm developing the amendment to the Final DNR.
- 6.1.4. The Design-Build Team shall include 1) all design costs associated with developing the amended Final DNR, including but not limited to all wall envelope details and 2) all design costs for all sound barrier walls, regardless of final quantity, as well as all costs associated with performing any additional geotechnical investigations necessary to design the foundations, in the lump sum price bid for the entire project.

6.2. Construction Cost Responsibility

- 6.2.1. In accordance with Subarticle 104-8(A) of the 2018 *Standard Specifications for Roads and Structures*, if the amended and accepted DNR and balloting process result in more than 410,000 square feet (sf) of sound barrier wall, the quantity of sound barrier wall over 410,000 sf will be paid for as extra work at the unit price of \$45.00 per square foot.
- 6.2.2. All work tasks required to construct the additional sound barrier walls, including but not limited to traffic control, pavement, drainage, concrete barrier, geotechnical investigation and earthwork shall be considered inclusive in the aforementioned unit price. The quantity of sound barrier wall eligible to be considered as of extra work shall be determined by subtracting from the total final quantity of sound barrier wall both (1) any additional sound barrier wall square footage required as a result of horizontal and/or vertical alignment

changes to the Roadway Plans provided by the NCTA and (2) and sound barrier walls removed from the accepted DNR due to the balloting process.

- 6.2.3. The Design-Build Team shall only credit the Department the construction cost of all sound barrier walls eliminated by the balloting process. The construction costs of all sound barrier walls eliminated solely by the balloting process shall be deducted from the lump sum amount bid for the entire project.

6.3. Ballotting

- 6.3.1. The Department will ballot all benefited receptors to determine which sound barrier walls recommended in the approved Final DNR will be constructed. The Design-Build Team shall (1) develop and provide the information required by the Department to complete the balloting process, and (2) attend and / or speak at all balloting meetings and workshops.
- 6.3.2. The Department will require four months to complete the balloting process. The Department will not honor any requests for additional contract time or compensation for the sound barrier wall construction unless the aforementioned four-month timeframe is exceeded. If time were granted, it would only be for that time exceeding the four-month period, which shall begin on the date the Department approves the Final DNR developed by the Design-Build Team.
- 6.3.3. The Design-Build shall not construct any sound barrier walls until the balloting process has been completed by the Department.

6.4. Miscellaneous Sound Barrier Wall Requirements

- 6.4.1. At all sound barrier walls, the Design-Build Team shall provide 1) a four-foot berm between the wall and fill / cut slopes steeper than 6:1 and 2) a parallel concrete ditch at locations where the final grade slopes toward the wall.
- 6.4.2. To satisfy the FHWA's Abatement Measure Reporting requirements, the Design-Build Team shall prepare and concurrently submit a summary of the sound barrier walls to be constructed on the project with the final sound barrier wall working drawings submittal. The Design-Build Team shall submit the sound barrier wall summary directly to the NCDOT Traffic Noise and Air Quality Group and include the information noted in Title 23 Code of Federal Regulations Part 772 Section 772.13(f), including, but not limited to, overall cost and unit cost per square foot.
- 6.4.3. For additional requirements regarding sound barrier walls, reference the *Structures Scope of Work*, *Geotechnical Engineering Scope of Work*, *Aesthetics Design Scope of Work* and the *Sound Barrier Wall Project Special Provision*.

7. MISCELLANEOUS

7.1. Retaining Walls

The Design-Build Team shall design and construct all retaining walls a minimum of ten-foot (measured from the exposed face of the wall) inside the right of way.

7.2. Clearance Calculations

For all bridges over roadways and railroads, the Design-Build Team shall submit vertical and horizontal clearance design calculations at all critical points. The Design-Build Team shall submit post construction survey points for the aforementioned critical points that verify construction adhered to the vertical and horizontal clearances accepted by the NCTA. The Design-Build Team shall be responsible for all costs associated with correcting vertical and horizontal clearances resulting from any construction variation from the design accepted by the NCTA.

7.3. Additional Environmental Considerations

- 7.3.1. The NCTA has followed the Section 6002 Process used by the Environmental Agencies and the NCTA to coordinate about environmental permits. Any variations in the NCTA's proposed design and / or construction methods that nullify any decisions reached between the NCTA and the Environmental Agencies; and / or require additional coordination with the Environmental Agencies shall be the sole responsibility of the Design-Build Team. The NCTA will not allow any contract time extensions or additional compensation associated with any coordination or approval process resulting from design and / or construction modifications.
- 7.3.2. Except as required elsewhere in this RFP and / or to eliminate a design exception, the Design-Build Team shall not further impact any cultural, historical or otherwise protected landmark or topographic feature beyond that shown on the Preliminary Roadway Plans provided by the Department.
- 7.3.3. The Design-Build Team shall drain all ponds located partially or completely within the right of way and easements.

7.4. Resurfacing Grades

- 7.4.1. Excluding construction areas that consist solely of pavement marking obliterations / revisions, gravel / soil roads, and haul roads, the Design-Build Team shall design and construct resurfacing grades for all roadways impacted by construction. All resurfacing grades shall adhere to the design criteria and standards, provide all required pavement wedging and adhere to the minimum requirements noted herein.
- 7.4.2. The Design-Build Team shall resurface all lanes and shoulders of an undivided facility throughout the limits of proposed widening and construction.

- 7.4.3. The Design-Build Team shall resurface each one-way roadway of a divided facility throughout the limits of the one-way roadway widening and construction, allowing varying resurfacing limits for the opposing directions of travel.
- 7.4.4. Unless noted otherwise elsewhere in this RFP, for both divided and undivided facilities, the Design-Build Team shall resurface all lanes and shoulders within the outermost construction limits of all proposed widening and construction, including any gaps along the facility where construction activities are not required.

7.5. Proposed Design Revisions

- 7.5.1. The Design-Build Team shall inform the NCTA, in writing, of all proposed design revisions as the design progresses from the Technical Proposal through final design in accordance with this Section 7.5.
- 7.5.2. The Design-Build Team shall note in the Technical Proposal any proposed deviations to the preliminary design shown on the Preliminary Roadway Plans provided by the Department. The Design-Build Team shall be responsible for all activities, as deemed necessary by the Department or the FHWA, resulting from changes to the NCTA preliminary design, including but not limited to, public involvement, NEPA re-evaluation and / or coordination with other stakeholders. The NCTA shall not honor any requests for additional contract time or compensation for completion of the required activities resulting from changes to the NCTA preliminary design.
- 7.5.3. After the contract has been awarded, the Design-Build Team shall inform the NCTA, in writing, of all proposed changes to the design shown in the Technical Proposal with the applicable design submittal.
- 7.5.4. After the NCTA has reviewed and accepted the Design-Build Team's design submittals, the Design-Build Team shall inform the NCTA, in writing, of any changes to previously reviewed submittals.
- 7.5.5. The proposed design revisions noted above shall be subject to the NCTA's review and acceptance.

7.6. Right of Way Markers

- 7.6.1. Prior to recording the Right of Way Plans, the Design-Build Team shall locate and install right of way markers that delineate the proposed right of way for all parcels within the project limits.
- 7.6.2. The Design-Build Team will be allowed to temporarily delineate the aforementioned proposed right of way with temporary metal caps and fiberglass markers prior to recording the Right of Way Plans. However, prior to final project acceptance, the Design-Build Team shall locate and install permanent concrete right of way markers to delineate the aforementioned proposed right of way. The Design-Build Team shall remove and dispose

of all metal caps and fiberglass markers used to temporarily delineate the proposed right of way.

- 7.6.3. For all parcels, the Design-Build Team shall locate and install metal caps with fiberglass markers that delineate all proposed permanent easements within the project limits. The Design-Build Team shall replace all existing right of way and permanent easement markers / monuments damaged and / or relocated during construction. [A Professional Land Surveyor registered in North Carolina shall certify the placement of all right of way and permanent easement markers/monuments.](#) In accordance with NCDOT Policy, the Department will furnish the metal caps with fiberglass markers.

7.7. Slopes

- 7.7.1. Unless noted otherwise elsewhere in this RFP, the maximum allowable cut and fill slope shall be 2:1. (Reference the *Geotechnical Scope of Work* found elsewhere in this RFP) The slopes in the interchange area shall follow the requirements set forth in the *Roadway Design Guidelines for Design-Build Projects* located on the Design-Build web site.
- 7.7.2. A 4:1 back slope shall extend from the back of the expressway gutter to the clear zone limit. Beyond that, a maximum 2:1 cut slope will be acceptable. The expressway gutter centerline shall be located at the hinge / shoulder point. Expressway gutter shall not be installed in fill sections. Expressway gutter shall only be used to minimize impacts to existing structures, and / or cultural, historical or otherwise protected landmarks or topographic features.
- 7.7.3. Cut and fill slope transitions shall not exceed one increment (i.e. 3:1 to 4:1) per 50 feet.

7.8. Use of NCDOT Right of Way for Borrow and Waste

- 7.8.1. Outside the Project limits, the Design-Build Team will not be allowed to use the NCDOT right of way and / or property for borrow or waste sites.
- 7.8.2. Within the Project limits, only clean waste material may be wasted within the NCDOT right of way or property.
- 7.8.3. Excluding crushed concrete, debris shall not be buried within the NCDOT right of way or property.
- 7.8.4. Normal grading operations shall occur, including but not limited to, removal of the existing embankments supporting all removed roadway sections.

7.9. Guardrail and Guiderail

- 7.9.1. Unless noted otherwise elsewhere in this RFP, all guardrail / guiderail placement shall be in accordance with the NCDOT *Roadway Design Manual* and the NCDOT *Roadway Standard Drawings* and / or approved details in lieu of standards. Along all 3:1 fill slopes,

constructed at fill heights that are equal to or greater than 12 feet, the Design-Build Team shall install guardrail. Along all fill slopes steeper than 3:1, constructed at fill heights that are equal to or greater than six feet, the Design-Build Team shall install guardrail. The guardrail / guiderail design shall be submitted for review with the Preliminary Plans submittal.

- 7.9.2. The Design-Build Team shall pave to the face of guardrail (and barrier rail) in accordance with the Pavement Management Scope of Work.
- 7.9.3. At all locations with paved shoulders that extend beyond the typical width (i.e. to the face of single face barrier and guardrail, edge of expressway / shoulder berm gutter, etc.), the Design-Build Team shall taper the wider paved shoulder width to the typical paved shoulder width using an 8:1 taper.

7.10. Barrier Rail and Barrier Rail Offsets

- 7.10.1. The Design-Build Team shall provide continuous single face concrete barrier between two segments of single face concrete barrier when 1) the two segments are less than 300 feet apart, and 2) guardrail would be required between the two segments.
- 7.10.2. At all locations where back to back single face concrete barrier is provided, including but not limited to bridge piers and sign supports, the Design-Build Team shall fill the area between the single face concrete barriers with gravel and cap with four inches of concrete.
- 7.10.3. Within the vehicle recovery area, the Design-Build Team shall design and construct single face concrete barrier in front of the traffic face of all sound barrier walls, retaining walls and all elements acting as a retaining wall. The aforementioned concrete barrier shall be located 1) beyond the typical section shoulder point and / or 2) a minimum of 12-foot behind the face of curb and gutter, requiring the Design-Build Team to widen the outside shoulder / berm beyond the typical section width.
- 7.10.4. Unless otherwise noted in this RFP, the Design-Build Team shall design and construct bridge rail offsets that are the greatest of (1) as indicated in the NCDOT Roadway Design Manual, (2) equal to the entire width of the approach roadway paved shoulders, or (3) equal to the width to accommodate the future sidewalk as required in the Structure Scope of Work. Narrower bridge rail offsets based on bridge length will not be allowed. For all bridges on the mainline (-L-), the minimum median bridge rail offset shall be 12 feet. In areas where sound barrier walls are adjacent to the shoulder approaching a bridge, the bridge width does not need to match the approaching 18-foot wide shoulder but instead can maintain a 12-foot offset on the bridge transitioning to the 18-foot shoulder off the bridge.

7.11. Miscellaneous Shoulder Requirements

- 7.11.1. The total outside shoulder width for all facilities with defined usable shoulders shall equal the values as shown in the NCDOT Roadway Design Manual (Reference Section 1-4B).
- 7.11.2. All paved shoulders shall be tapered at 8:1 to the existing pavement at tie-in points.

7.11.3. Shoulder berm gutter shall not be installed in cut sections.

7.12. Miscellaneous Design and Construction Requirements

7.12.1. Unless noted otherwise elsewhere in this RFP, the design speed for all roadways shall be the greater of the minimum design speed for the facility type, as specified in the 2011 AASHTO A Policy on Geometric Design of Highways and Streets, or the anticipated / actual posted speed plus five mph. If a speed limit is not physically posted on an existing facility, General Statutes mandate the speed limit as 55 mph, resulting in a 60 mph design speed.

7.12.2. Excluding grades required to tie to existing, the minimum longitudinal grade shall be 0.30%.

7.12.3. A sag vertical curve low point will not be allowed on any proposed bridge or approach slab or in a superelevation transition area of flat cross slope.

7.12.4. The Design-Build Team shall identify the need for any special roadway design details (i.e. any special drainage structures, rock embankment, rock plating, special guardrail, retaining walls, concrete barrier designs, etc.) and shall provide special design drawings. The Contract Standards and Development Unit may have special details available that can be provided to the Design-Build Team upon request.

7.12.5. The Design-Build Team shall design and construct horizontal and vertical curves at all Points of Intersections (PIs) on the horizontal and vertical alignments, respectively.

7.12.6. The Design-Build Team shall contact Mr. Gary W. Thompson, North Carolina Geodetic Survey Director, prior to disturbing any geodetic monument.

7.12.7. The minimum width of all grass covered islands / raised medians shall be eight feet, measured face to face from the surrounding mountable concrete curb and gutter or from edge of pavement to edge of pavement, as appropriate. All grass covered islands shall be constructed with topsoil and appropriate cross slope and median drain with pipe to prevent groundwater and surface water infiltration into the subgrade and / or pavement structure. Prior to construction of the grass covered islands and / or raised median drain with pipe, the Design-Build Team shall submit to the Design-Build Unit, for review and acceptance, the proposed number of drains, drain locations within the typical section, topsoil specifications and construction details. Within all proposed grass covered island limits, the Design-Build Team shall completely remove and dispose of the existing pavement structure.

7.13. Miscellaneous Design Coordination

7.13.1. The Design-Build Team shall submit Structure Recommendations and Design Criteria for NCDOT review and acceptance prior to the Preliminary Roadway Plans submittal. The Design-Build Team shall develop Structure Recommendations that adhere to the format

noted in the March 25, 2003 and September 1, 2004 memos from Mr. Jay Bennett, PE, former State Roadway Design Engineer.

- 7.13.2. The project shall follow the NCDOT-FHWA Oversight Agreement. This agreement will be provided. Any changes that affect previous approvals shall be re-submitted by the Design-Build Team for FHWA acceptance.

8. PRINCIPLE STANDARDS

8.1. Design and Construction Standards

Unless allowed otherwise elsewhere in this RFP, the design shall be in accordance with the 2011 AASHTO *A Policy on Geometric Design of Highways and Streets* and 2013 Errata, 2002 NCDOT *Roadway Design Manual*, including all revisions effective on the Technical Proposal submittal date, January 2018 NCDOT *Roadway Standard Drawings*, or as superseded by detail sheets located at <https://connect.ncdot.gov/resources/Specifications/Pages/2018-Roadway-Standard-Drawings.aspx>, *Roadway Design Policy and Procedure Manual*, *Roadway Design Guidelines for Design-Build Projects*, 2018 NCDOT *Standard Specifications for Roads and Structures* and the 2011 AASHTO *Roadside Design Guide*, 4th Edition and 2015 Errata.

8.2. Conflict in Design Standards

If the NCDOT *Roadway Design Manual*, including all revisions, the 2011 AASHTO *A Policy on Geometric Design of Highways and Streets* and 2013 Errata, the 2018 NCDOT *Roadway Standard Drawings* and / or any other guidelines, standards or policies have desirable and / or minimum values, the Design-Build Team shall use the desirable values unless noted otherwise elsewhere in this RFP. Similarly, in case of conflicting design parameters, and / or ranges, in the various resources, the proposed design shall adhere to the most conservative values, unless noted otherwise elsewhere in this RFP.

9. NCDOT INFORMATION SUPPLIED

9.1. Environmental Documentation

The NCDOT will provide copies of the Complete 540 Draft Environmental Impact Statement, the Complete 540 Final Environmental Impact Statement, the Complete 540 Record of Decision, and the latest list of environmental commitments, municipal agreements and all pertinent approvals and correspondence. Unless noted otherwise elsewhere in this RFP, the Design-Build Team shall adhere to all commitments stated in the environmental documents.

9.2. Surveys

The NCTA will provide electronic surveys to the Design-Build Team. Any supplemental surveys, including but not limited to additional topography, existing and proposed roadway, structure sites, underground and overhead utilities, existing and proposed drainage, wetland delineation, right of way, parcel names, and deed research and descriptions shall be the responsibility of the Design-Build Team to acquire and process. [All supplemental surveys shall adhere to the Location and](#)

Survey Unit's September 28, 2018 Proc 2018-4 – L&S Implementation of SharePoint Site Guidelines and Proc 2018-6 – L&S Required PEF Attestations for Individually Developed Survey Products Memorandums. The Design-Build Team shall modify / incorporate boundary information used for the determination and valuation of property solely under the direct supervision of a Professional Land Surveyor registered in North Carolina. Known existing utilities have been located and will be included with the survey data. The Design-Build Team shall be responsible for confirming the location of the utilities and the type / size of facilities. All supplemental Subsurface Utility Engineering (SUE) work shall be the responsibility of the Design-Build Team.

9.3. Roadway Plans

9.3.1. The NCDOT will provide the R-2721B Preliminary Roadway Plans and the Roadway Right of Way Plans developed by the NCTA. The Design-Build Team is cautioned that the preliminary design is provided solely to assist the Design-Build Team in the development of the project design. The Design-Build Team shall be fully and totally responsible for the accuracy and completeness of the project design, including, but not limited to, the use of the NCTA's design, the use of portions of the NCTA's design or modifications to the NCDOT's design.

9.3.2. The NCTA will provide the R-2721A electronic design files.

9.4. Pavement Design

The NCDOT will provide final pavement design alternative options for R-2721A. The Design-Build Team shall be responsible for all temporary pavement designs. (Reference the *Pavement Management Scope of Work* found elsewhere in this RFP)

9.5. Geotechnical Investigation

The NCTA will provide a Geotechnical Subsurface Investigation for R-2721A. The Design-Build Team shall be responsible for any additional geotechnical information, all geotechnical recommendations, as well as supplemental structural and roadway investigations.

PAVEMENT MANAGEMENT SCOPE OF WORK

(11-7-18)

1. MAINLINE PAVEMENT DESIGN AT WEST END OF PROJECT

The Design-Build Team shall construct mainline travel lanes, inside shoulders, and outside shoulders following the pavement design in Table 1 for the project limits from the tie in at Station 11+50 to the end of the western approach slabs for the bridges on NC 540 over East Williams Street.

Table 1 Mainline Pavement Design (West of Bridges on -L- over -Y2-)

Mainline Travel lanes	Mainline Inside Shoulder and Outside Shoulders
13.5" Doweled Jointed Concrete 3.0" B25.0C 1.25" S9.5B Subgrade Stabilization	11.0" Undoweled Jointed Concrete

Notes: (1) The mainline outside concrete pavement structure shall be 14 feet wide, with two feet located within the mainline outside paved shoulder.

(2) Where proposed travel lanes overlap with the existing paved shoulder, the Design-Build Team shall remove and dispose of / recycle the existing shoulder pavement structure and rebuild with the mainline travel lane pavement design and relocate the existing shoulder drains. This also applies to the existing gore area to become travel lane.

2. MAINLINE PAVEMENT ALTERNATES

The Design-Build Team shall choose one of the following pavement designs for the mainline travel lanes, inside shoulders, and outside shoulders for the project limits from the end of the eastern approach slabs for the bridges on NC 540 over East Williams Street to east of Pierce-Olive Road at Station 240+00 -L-. The Design-Build Team shall specify the pavement alternate chosen in the Technical Proposal.

2.1. Alternate 1 – Concrete Pavement with Tied Concrete Shoulders

2.1.1. The travel lane pavement design for **Alternate 1** shall consist of the following:

12.0" Doweled Jointed Concrete
Nonwoven Geotextile Drainage Interlayer
1.25" S9.5B
Subgrade Stabilization

- 2.1.2. The median shoulder and outside shoulder pavement design for **Alternate 1** shall consist of the following:

12.0" Undoweled Jointed Concrete
1.25" S9.5B
Subgrade Stabilization

2.2. Alternate 2 – Concrete Pavement with Asphalt Shoulders

- 2.2.1. The travel lane pavement design for **Alternate 2** shall consist of the following:

12.0" Doweled Jointed Concrete
Nonwoven Geotextile Drainage Interlayer
1.25" S9.5B
Subgrade Stabilization

- 2.2.2. For each direction of travel, the mainline concrete pavement structure shall be 37 feet wide, with one foot located within the mainline outside paved shoulder.

- 2.2.3. The pavement design for the median shoulder and the remaining 11 feet of the outside shoulder for **Alternate 2** shall consist of the following:

3.0" S9.5C
4.0" I19.0C
6.25" B25.0C
Subgrade Stabilization

2.3. Alternate 3 – Concrete Pavement with Roller Compacted Concrete Shoulders

- 2.3.1. The travel lane pavement design for **Alternate 3** shall consist of the following:

12.0" Doweled Jointed Concrete
Nonwoven Geotextile Drainage Interlayer
1.25" S9.5B
Subgrade Stabilization

- 2.3.2. For each direction of travel, the mainline concrete pavement structure shall be 37 feet wide, with one foot located within the mainline outside paved shoulder.

- 2.3.3. The pavement design for the median shoulder and the remaining 11 feet of the outside shoulder for **Alternate 3** shall consist of the following:

9.0" Roller Compacted Concrete
Variable Depth ABC (4.25" Minimum)
Subgrade Stabilization

- 2.3.4. The 9.0" roller compacted concrete (RCC) shall have transverse joints matching the adjacent travel lane pavement.

- 2.3.5. If the Design-Build Team elects Alternate 3 for the shoulders, then utilize personnel or a subcontractor that has either (1) performed a minimum of 10 lane miles of RCC construction on a roadway project(s) with quality results and smooth texture appearance or (2) a minimum of 300,000 square feet of RCC construction on a roadway project(s) with quality results and smooth texture appearance and can demonstrate to the NCTA's satisfaction that the entity performing the RCC construction has the equipment and experienced personnel necessary to construct high quality RCC pavement. The Design-Build Team shall clearly detail the qualifications of the personnel or subcontractor proposed for RCC in their Technical Proposal, along with examples and quality results of the roadway RCC shoulder construction previously performed by such personnel or subcontractor. In addition, a RCC industry representative, with specific expertise in RCC highway application, shall be on site during placement operations and shall attest to the quality of the product and smoothness.
- 2.3.6. For RCC requirements, see *Roller Compacted Concrete* Project Special Provision found elsewhere in this RFP.

2.4. Alternate 4 – Asphalt Pavement (Full Depth Asphalt)

- 2.4.1. The travel lane pavement design for **Alternate 4** shall consist of the following:

3.0" S9.5D

4.0" I19.0C

8.0" B25.0C

Subgrade Stabilization

- 2.4.2. The pavement design for the median shoulders and outside shoulders for **Alternate 4** shall consist of the following:

3.0" S9.5C

4.0" I19.0C

8.0" B25.0C

Subgrade Stabilization

2.5. Alternate 5 – Asphalt Pavement with Aggregate Base Course

- 2.5.1. The travel lane pavement design for **Alternate 5** shall consist of the following:

3.0" S9.5D

4.0" I19.0C

4.0" B25.0C

8.0" ABC

Subgrade Stabilization

- 2.5.2. The pavement design for the median shoulders and outside shoulders for **Alternate 5** shall consist of the following:

3.0" S9.5C

4.0" I19.0C

4.0" B25.0C

8.0" ABC

Subgrade Stabilization

3. OTHER MAINLINE PAVEMENT REQUIREMENTS

3.1. Requirements Specific to Alternates 1, 2, and 3

- 3.1.1. The Nonwoven Geotextile Drainage Layer shall be in accordance with Section 724 of the 2018 NCDOT Standard Specifications. The Nonwoven Geotextile Drainage Interlayer and the S9.5B layer shall extend to the shoulder drains.
- 3.1.2. The transverse joints shall be uniformly spaced 15 feet apart.
- 3.1.3. The Design-Build Team shall diamond grind new concrete pavement in accordance with the *Diamond Grinding Concrete Pavement Project Special Provision* found elsewhere in this RFP.

3.2. Requirements for All Alternates

- 3.2.1. All longitudinal joints shall be located on a lane line. Solely to shift a longitudinal joint to one of the aforementioned locations, a maximum 840-foot transition, that locates the longitudinal joint elsewhere, will be allowed. The Design-Build Team shall indicate in the Technical Proposal how longitudinal joints will be located on a lane line.
- 3.2.2. Chemical stabilization shall be to a minimum depth of 8 inches for lime and 7 inches for cement. The type of subgrade stabilization and the amount of stabilizing agent shall be determined in accordance with the *Cement and Lime Stabilization of Sub-grade Soils Project Special Provision* found elsewhere in this RFP. Only one type of chemical stabilization shall be used across the full typical section width, in a given direction, and shall be used for a minimum 1000-foot length.
- 3.2.3. The requirements contained in Sections 4.2.8 and 4.2.11 in this Scope of Work also apply to the mainline.
- 3.2.4. For additional geotextile requirements, reference the *Geotechnical Engineering Scope of Work*.
- 3.2.5. Unless noted otherwise elsewhere in this RFP, the Design-Build Team shall extend the selected pavement alternate full depth shoulder 1) from the edge of all paved shoulders to the face of all single face barrier/guardrail, 2) from the edge of all paved shoulders to the

edge of all expressway / shoulder berm gutter, and 3) from the edge of all paved shoulders to the face of proposed retaining walls and sound barrier walls located on the outside shoulder.

3.3. Shoulder Drains

- 3.3.1. Excluding the high side of superelevated sections, the Design-Build Team shall design and construct continuous median and outside shoulder drains and outlets for the mainline concrete pavement alternate.
- 3.3.2. Excluding the high side of superelevated sections, the Design-Build Team shall design and construct median and outside shoulder drains and outlets at the locations noted below for the mainline asphalt pavement alternates:
- Throughout crest vertical curves located in cut sections
 - Throughout all sag vertical curves
 - Where the grade is less than 1%.
- 3.3.3. Where installed on the outside shoulder, outlets shall be provided approximately every 300 feet. Where installed on the median shoulder, outlet locations shall not exceed 500 feet, and all outlets shall be located at drainage structures. Shoulder drains shall be placed to drain the entire depth of the pavement structure. The shoulder drain design and outlet locations shall be submitted to NCTA for review and acceptance.
- 3.3.4. After completion of the shoulder drain installation and mainline paving but before shoulder paving, the Design-Build Team shall perform a review of the completed shoulder drain. Document the review by a written report and video recording and furnish both to the Engineer. Video equipment shall satisfy the following requirements:
- Use a high resolution, high sensitivity, waterproof video camera that is capable of inspecting pipes from three inches to six inches in diameter in a wet environment.
 - The camera must be capable of negotiating a ninety-degree bend in smooth bore or corrugated pipe.
 - Sufficient lighting must be provided to provide a clear picture of the entire periphery of the pipe.
 - Maintain the camera in the center of the pipe during all inspections.
 - Equip the system with a video monitor capable of allowing live viewing of the inspection.
 - Use a system that will display and record the date, line identification and footage. The system shall also record the distance traversed by the camera to within 0.5 feet.
 - Use a system that is capable of performing inspections of up to 300 linear feet of lateral drains (excluding outlets).
- 3.3.5. All outlets and outlet treatments in a run must be completely installed before beginning the shoulder drain inspection.

- 3.3.6. Any obstruction that prohibits this inspection and/or the proper function of the shoulder drain shall be removed by a method acceptable to the Engineer. Any shoulder drain that is determined to be damaged, non-functional, or not reasonably close to the established line and/or grade shall be removed and replaced at no expense to NCTA.
- 3.3.7. Any traffic control necessary to accomplish this review shall be the responsibility of the Design-Build Team. Any line that requires repair and/or replacement shall be re-inspected before final acceptance to ensure proper function. There will be no consideration for additional compensation or time for inspecting, repairing and/or replacing shoulder drains.

3.4. All Electronic Tolling Gantry Locations

For specific pavement design and construction requirements in the immediate vicinity of toll gantries, reference the All Electronic Tolling Toll Zone Infrastructure Scope of Work.

4. -Y- LINE PAVEMENT

4.1. -Y- Line Pavement Designs

4.1.1. Other pavement designs for this project are provided in Table 2 below:

Table 2

Lines on R-2721A	Surface	Intermediate	Base	ABC	Subgrade Stabilization
NC 55 Bypass (-Y1-)	3.0" S9.5C	4.0" I19.0C	11.0" B25.0C	-	No
East Williams Street (-Y2-)	3.0" S9.5C	3.0" I19.0C	4.0" B25.0C	-	No
-Y1RPB-, -Y1RPC-, -Y1LPB-, -Y1RPD-	3.0" S9.5C	4.0" I19.0C	-	8"	Yes
-Y3- & -Y4- (SR 1301, Sunset Lake Road), -Y5- (SR 1152, Holly Spring Road), -Y5NB-, -Y5SB-, -Y5A- (SR 1300 Kildaire Farm Road)	3.0" S9.5B	4.0" I19.0C	-	8"	No
-Y5RPA-, -Y5RANB-, -Y5RASB-, -Y5RPD-, -Y5RPDSB-, - Y5RPDNB-, -Y5RPB-, - Y5RPBNB-, -Y5RPBSB-, -Y5RPC- , -Y5RPCNB-, -Y5RPCSB-	3.0" S9.5C	2.5" I19.0C	-	8"	Yes

-Y5B- (Sancroft Drive), -Y5C- (Old Center Street), -Y5D- (Lockley Road), -Y5E- (Catherine Place), -Y5F-, -Y5G- (Holly run Road), -Y5H-, -Y5I-, -Y5J-, -Y5K- (Aviary Court), -Y5L- (Ness Drive), -Y5M-	3.0" S9.5B	-	-	8"*	No
Y6 (SR 1389, Pierce-Olive Road)	3" S9.5B	-	-	10"*	No
Service Roads	3" S9.5B	-	-	8"*	No

* Use prime coat at normal application rate.

4.1.2. When required in Table 1, subgrade stabilization shall be included in accordance with Sections 3.2.2, 3.2.3, and 3.2.4 of this Scope of Work.

4.1.3. For the -Y- Lines, ramps, loops and service road pavement designs noted in Table 1 above, the Design-Build Team may substitute an asphalt base course layer for the ABC layer or vice versa. The additional thickness of the asphalt base course, used as a substitute for the ABC layer, shall be equal to half of the proposed ABC thickness specified for the roadway. The thickness of the ABC layer, used as a substitute for the asphalt base layer, shall be equal to twice the proposed asphalt base layer thickness specified for the roadway. If an asphalt surface course is placed directly on the ABC layer, the Design-Build Team shall apply prime coat.

4.1.4. The Design-Build Team shall maintain the same pavement design throughout the -Y- Line, ramp, loop, and service road construction limits. In the Technical Proposal, the Design-Build Team shall specify the base option chosen (ABC or asphalt) for all -Y- Lines, ramps, loops and service roads. The Design-Build Team may substitute an asphalt base course layer for an ABC layer, as described above, for tie-ins and narrow widening.

4.2. Other -Y- Line Pavement Requirements

4.2.1. For the -Y- Lines, ramps, loops and service road pavement designs noted in Table 1 above, the Design-Build Team shall resurface the existing pavement with a minimum pavement depth that equals the full thickness of the surface course as provided in Table 1 (Reference the *Roadway Scope of Work* found elsewhere in this RFP).

4.2.2. On all ramps and loops, the adjacent through lane pavement design shall extend to the back of the gore (12-foot width).

4.2.3. Longitudinal joints of all surface course layers shall not be located in the final traffic pattern wheel path. If applicable, the Design-Build Team shall indicate in the Technical Proposal where all underlying longitudinal joints will be located and demonstrate how the underlying longitudinal joint location will minimize reflective cracking.

- 4.2.4. Unless noted otherwise elsewhere in this RFP, the minimum widened width shall be six feet. The minimum widened width may be reduced to four feet only if the Design-Build Team demonstrates that their equipment properly compacts narrow widening and obtains prior NCTA written approval. Tapers that tie proposed pavement to existing pavement are excluded from the narrow widening requirements noted above.
- 4.2.5. In areas where the existing -Y- Line or ramp paved shoulders are proposed to be incorporated into a permanent travel lane, the Design-Build Team shall be responsible for evaluating the existing paved shoulder and base regarding its suitability for carrying the projected traffic volumes. In the event that the existing paved shoulder is found to be inadequate, the Design-Build Team shall be responsible for upgrading the existing paved shoulder to an acceptable level or replacing the existing paved shoulder. The Design-Build Team shall submit their evaluation and proposed use of existing paved shoulders to the Design-Build Unit for review and acceptance or rejection.
- 4.2.6. Unless noted otherwise elsewhere in this RFP, the Design-Build Team shall extend the full depth pavement 1) from the edge of all paved shoulders to the face of all single face barrier/guardrail, 2) from the edge of all paved shoulders to the edge of all expressway / shoulder berm gutter and curb and gutter, and 3) from the edge of all paved shoulders to the face of proposed retaining walls and sound barrier walls located on the outside shoulder.
- 4.2.7. When a resurfacing grade ties to an existing curb, bridge and / or pavement, the Design-Build Team shall perform incidental milling such that the new pavement ties flush with the existing feature(s). When tying to the aforementioned feature(s), the Design-Build Team shall not reduce the minimum required surface layer pavement thickness noted above. At existing pavement ties, the Design-Build Team shall perform incidental milling for a minimum distance of 37.5 feet at bridges and six feet at curb sections. The Design-Build Team shall not perform incidental milling more than 72 hours prior to placement of the asphalt surface layer.
- 4.2.8. The Design-Build Team shall place a minimum of 6" of ABC (or a minimum of 4" B25.0C) under all single face barrier, expressway / shoulder berm gutter, curb and gutter, and concrete truck aprons.
- 4.2.9. All driveways, up to the radius point, shall be constructed with the full-depth pavement design of the intersecting roadway. The entire impacted length of all non-concrete driveways with a minimum 10% grade shall be constructed with 1.5" S9.5B (or S9.5C) and 8" ABC with prime coat. Unless otherwise noted above, the Design-Build Team shall adhere to the following for all driveway construction:
- For existing gravel and soil driveways, use 8" ABC
 - For existing asphalt driveways, use 1.5" S9.5B (or S9.5C) and 8" ABC with prime coat
 - For existing concrete driveways, use 6" jointed concrete reinforced with woven wire mesh
- 4.2.10. The Design-Build Team shall be responsible for the design of all temporary pavements and for the evaluation of existing shoulders, bases and roadways regarding their

suitability for carrying traffic during construction, if necessary. In the event that the existing shoulders, bases and / or roadways are found to be inadequate for the proposed temporary traffic volumes and durations, the Design-Build Team shall be responsible for upgrading the pavement to an acceptable level. Temporary pavements shall be designed in accordance with NCDOT Pavement Design Procedure, AASHTO 1993 Method dated March 16, 2018. Temporary pavement designs and associated calculations shall be submitted for review and acceptance using the Design-Build submittal process prior to incorporation. The expected duration for traffic on temporary pavement must be included as part of the submittal.

- 4.2.11. The rate of application and the maximum and minimum thickness per application and layer shall be in accordance with the NCDOT Roadway Design Manual and 2018 NCDOT Asphalt QMS manual.

5. ALTERNATIVE TECHNICAL CONCEPTS (ATCs)

5.1. Conditions for Pavement Related ATCs

ATCs on pavement design will be permitted on the mainline, -Y- Lines, ramps, loops, and service roads, including travel lanes and shoulders, subject to the conditions outlined herein.

- 5.1.1. Pavement related ATCs shall not be submitted prior to the issuance of the Second Industry Draft RFP.
- 5.1.2. The pavement design in the ATC shall be determined using the method in the NCDOT Pavement Design Procedure, AASHTO 1993 Method dated March 16, 2018.
- 5.1.3. For all incorporated mainline, ramp and loop ATC pavement designs, including travel lane and shoulder pavement designs, the Design-Build Team shall include in the Technical Proposal a minimum two-year extension of the 3-year guarantee. (Reference the *Three Year Guarantee* Project Special Provision found elsewhere in this RFP).
- 5.1.4. Any mainline pavement design in the ATC shall include subgrade stabilization in accordance with Sections 3.2.2, 3.2.3, and 3.2.4 of this Scope of Work.
- 5.1.5. Any concrete mainline pavement design in the ATC shall include uniform 15-foot joint spacing.
- 5.1.6. Any concrete mainline (and mainline shoulder under Alternate 1) pavement design in the ATC shall have concrete that is at least 11.5" thick concrete and have a base that is non-erodible and includes a permeable drainage layer and a separator layer below the drainage layer (must drain the pavement structure while protecting the subgrade from moisture).
- 5.1.7. Any asphalt mainline pavement design in the ATC shall be at least 13" thick for full depth asphalt or at least 9.5" of asphalt, including 3.0" of S9.5D, above a minimum of 8" of ABC.

- 5.1.8. Any -Y- Line, ramp, loop and service road pavement designs in the ATC, including travel lanes and shoulders, and the mainline asphalt shoulder pavement design shall have a total minimum thickness equal to the total thickness specified in this Scope of Work.

5.2. Process for Pavement Related ATCs

- 5.2.1. The pavement design in the ATC shall be signed and sealed by a professional engineer that has experience in pavement design and who is registered in the State of North Carolina. The ATC submittal shall include a brief resume or description of the designer's pavement design experience.
- 5.2.2. ATCs complying with the above restrictions will be evaluated by a technical review panel in accordance with the usual ATC process with the exception that the NCTA reserves the right to engage a recognized pavement design expert to assist with the ATC evaluations. (Reference the *Alternative Technical Concepts and Confidential Questions* Project Special Provision found elsewhere in this RFP).

STRUCTURES SCOPE OF WORK

(11-7-18-10-19)

1. PROJECT SCOPE

1.1. Required Bridges

The Design-Build Team shall design and construct all structures necessary to complete the project, including, but not limited to, the following:

- Bridge on Triangle Expressway eastbound over NC 55 Bypass
- Dual Bridges on Triangle Expressway (and NC 55 Bypass ramps) over E. Williams Street (NC 55)
- Dual Bridges on Triangle Expressway over Middle Creek
- SR 1301 (Sunset Lake Road) over Triangle Expressway (westernmost crossing)
- SR 1301 (Sunset Lake Road) over Triangle Expressway (easternmost crossing)
- SR 1152 (Holly Springs Road) over Triangle Expressway
- SR 1389 (Pierce Olive Road) over Triangle Expressway

1.2. Other Structures

The Design-Build Team shall construct all other structures necessary for the project including:

- Single 14' x 10' reinforced concrete box culvert at approximate -L- Station 79+70 for future Middle Creek Greenway (structure only)
- Quad 12' x 8' reinforced concrete box culvert at -Y3- Sunset Lake Road (SR1301) Station 15+50 at Middle Creek (shown as bridge on Design Public Hearing Map)
- Single 14' x 10' reinforced concrete box culvert at approximate -L- Station 124+60 for existing Woodcreek multi-use path (not shown on Design Public Hearing Map)
- All retaining walls required by their design.
- All noise walls required by their design (Reference the *Roadway Scope of Work* found elsewhere in this RFP)
- All reinforced concrete box culverts/reinforced concrete box culvert extensions required by their design
- All sign structures, gantries, and All Electronic Toll infrastructure buildings as described elsewhere in this RFP. Foundations for toll gantries that include spread footings, grade beams, etc. shall be designed and constructed such that the top plane of the footing is no higher than 2 ft. below the finished grade to ensure cabinet placement above the footing is possible.

1.3. Bridge Geometry

- 1.3.1. All bridges shall meet approved roadway typical sections and grades. Bridge geometry (width, length, skew, span arrangement, etc.) shall be in accordance with the accepted Structure Recommendations developed by the Design-Build Team and/or the accepted

Hydraulic Bridge Survey Reports except as may be noted herein.

1.3.2. The minimum vertical clearance for bridges constructed over all interstates, freeways and arterials shall be 17'-0".

1.3.3. Where the Design-Build Team retains the over/under arrangement for the -Y- lines and mainline shown in the Roadway Plans provided by the NCTA, each bridge shall have the same or better provisions for lanes, sidewalks, bike lanes, etc. as shown in the R-2721 Structure Recommendations dated October 29, 2018~~-,~~ except:

(1) At NC 55 Bypass, the outside shoulder for the southbound lane shall be 6 feet under the Triangle Expressway bridges.

(2) For E. Williams Street, a 5'-0" sidewalk shall be constructed in accordance with Section 4.3 of the Roadway Scope of Work.

(3) At Sunset Lake Road (-Y3-) over Triangle Expressway, the left sidewalk (north side of the bridge) shall be 8'-0" on the bridge.

When the Design-Build Team inverts the -Y-lines and mainline from that shown on the Roadway Plans provided by the NCTA, as permitted at certain crossings, reference Section 1.4.3 of this Structure Scope of Work for requirements.

~~1.3.3.~~1.3.4. The minimum vertical clearance for bridges constructed over all local roads and collector roads shall be 15'-6".

~~1.3.4.~~1.3.5. For bridges over the Triangle Expressway, interior bents in the median shall be located in the center of the median and skewed to parallel the mainline.

~~1.3.5.~~1.3.6. Except at stream crossings, MSE wall vertical end bents shall be used for all bridges on the project, whether the bridges carry the Triangle Expressway or a -Y- line. Spill through slopes shall be used for all wetland/stream crossings. The term "MSE wall" includes any vertical wall type abutment, including cast-in-place abutments, soil nail walls, and mechanically stabilized earth walls.

~~1.3.6.~~1.3.7. The minimum horizontal setbacks from the closest edge of travel lane to face of barrier in front of walls shall be 18'-0" for new bridges over interstates, freeways, and arterials. For bridges over loops constructed with this project, the minimum horizontal setback from the outside edge of the loop (loop acceleration lane) to the face of the barrier in front of walls shall be 10'-0". The minimum horizontal setback from the closest face of curb and gutter to the face of barrier in front of walls shall be 12'-0" for new bridges over all curb and gutter facilities. For new bridges over local roads and collectors that do not have curb and gutter, and for all new bridges over ramps, minimum horizontal setbacks should be in accordance with the NCDOT Roadway Design Manual.

~~1.3.7.~~1.3.8. Bridges over waterways and wetlands shall be designed and constructed to match or exceed the length of the bridges as shown on the Roadway Plans. If the bridge location is changed due to a change in alignment, then the bridge toe of slope shall be outside the wetland boundary and provide sufficient waterway opening and satisfy the requirements of the *Hydraulics Scope of Work*. These bridges shall have spill through slopes with rip rap protection.

1.4. Bridge Details

- 1.4.1. All proposed bridge barrier rails shall be per Standard Drawing CBR1 unless noted otherwise elsewhere in this RFP.
- 1.4.2. A Two-Bar Metal Rail shall be used on all structures with sidewalks, multi-use paths, or designated to have future sidewalks. The top of the parapet for the Two-Bar Metal Rail shall be set 2'-3" above the sidewalk or future sidewalk. For separation between travel lanes and multi-use paths, use Standard CBR2 or an approved vertical face barrier rail.
- 1.4.3. Bridges shall be designed and constructed in accordance with the Structure Recommendations developed by the Design-Build Team and accepted by the Department, except as noted herein. An ATC will be required in the event the Design-Build Team wishes to invert a -Y- line going over or under the mainline at the East Williams Street and Holly Springs Road crossings from that shown on the Roadway Right of Way Plans. In the event the Design-Build Team inverts a -Y- line going over or under the mainline from that shown on the Roadway Right of Way Plans at the other crossings, the minimum bridge length/width shall be designed and constructed in accordance with the following:

SR 1301 (Sunset Lake Road) under Mainline (both locations)	The mainline dual bridges shall span two lanes in each direction (11'-0" inside lanes and 14'-0" outside shared bicycle lanes), a 16'-0" two-way turn lane, and a 2'-0" gutter and a 10'-0" berm that includes a 5'-6" sidewalk on both sides.
SR 1389 (Pierce Olive Road) under Mainline	The mainline dual bridges shall span one 12'-0" lane in each direction with an 8'-0" shoulder in both directions.

- 1.4.4. The number of expansion joints for each structure shall be kept to a minimum. Structures shall be integral if the criteria listed in the NCDOT *Structures Management Unit Manual* is met. The criteria in Section 6.2.3.2 of the NCDOT *Structures Management Unit Manual* shall apply to all roadways, including Secondary Routes that meet the criteria for North Carolina Routes.

1.5. Aesthetics

- 1.5.1. Bridges (excluding stream crossings), retaining walls, sound barrier walls, signs, and gantries shall have aesthetic treatments as more fully described in the Aesthetic Design Scope of Work. Reference Section 2.6 of the *Aesthetics Design Scope of Work* for barrier rail color requirements on stream crossings.
- 1.5.2. The Design-Build Team shall apply anti-graffiti coating on all exposed surfaces of sound barrier walls (front and back), retaining walls, concrete barrier walls in front of all retaining walls, and MSE walls.

1.6. Box Culverts

- 1.6.1. As required by their design, the Design-Build Team shall design and construct all proposed reinforced concrete box culverts and lengthen or replace all existing reinforced concrete box culverts. Reinforced concrete box culvert designs shall be in

accordance with the Hydraulic Culvert Survey Reports, as may be amended by the Design-Build Team and accepted by the NCTA. (Reference the *Hydraulics Scope of Work*).

1.7. Noise Walls

The Design-Build Team shall design and construct all noise walls required by the Design-Build Team's design. (Reference the *Roadway Scope of Work* found elsewhere in this RFP). Regardless of wall height, noise walls shall be designed in accordance with the latest edition of the AASHTO *LRFD Bridge Design Specifications*.

2. GENERAL REQUIREMENTS

2.1. Design Team Qualification

The Design-Build Team's structure design firm(s) shall be on the NCDOT's list of firms qualified for structure design and maintain an office in North Carolina.

2.2. Structure Numbers

The Design-Build Team shall obtain Structure Numbers from NCDOT for all new bridges. For proposed bridges, the Design-Build Team shall include Structure Numbers on the applicable design layout sheets, all plans, and all correspondence with NCDOT pertaining to bridge work.

2.3. Prestressed Florida I-Beams, Prestressed Concrete Committee for Economic Fabrication Prestressed Concrete Girders, and Modified Bulb Tee Girders

Use of Florida Department of Transportation Prestressed Florida I-Beams (FIB), the Prestressed Concrete Committee for Economic Fabrication (PCEF) prestressed concrete girders, and Modified Bulb Tee girders will be allowed. The structural details associated with the items, including but not limited to mild reinforcing and reinforcing cover, shall be subject to NCTA review and acceptance post-award.

2.4. Construction and Materials

Unless noted otherwise elsewhere in this RFP, all construction and materials shall be in accordance with 2018 NCDOT *Standard Specifications for Roads and Structures*, NCDOT *Structures Management Unit Project Special Provisions* and NCDOT *Structures Management Unit Standard Drawings*.

2.5. Prohibitions

2.5.1. Prohibited Bridge Elements

Unless noted otherwise elsewhere in this RFP, the following will not be allowed on the project:

- Cored slab, box beam, fracture critical, deck girder and cast-in-place deck slab bridges
- Precast barrier rails
- Metal plate arch culverts
- Precast concrete culverts

- Interior pile bents at roadway grade separations
- Monotube or cantilever DMS (if required on project) support structures
- Excluding any required closed drainage systems and the ITS conduit, bridge attachments in the overhang of bridge structures (outside of exterior girders)
- Casting of conduit in the bridge deck or barrier rail
- Bridge piers adjacent to an outside roadway shoulder
- Modular expansion joints
- Attachment of sign structures to bridges
- Fracture critical structures

2.5.2. Design Practices

- Alternate designs, details or construction practices (such as those employed by other states, but not standard practice in NC) are subject to NCTA review and approval, and will be evaluated on a case by case basis.

3. PRINCIPLE STANDARDS

Perform all work in accordance with the latest publication of the following effective on the Technical Proposal submittal date, including all revisions, errata, addenda, etc., effective on the Technical Proposal submittal date unless noted otherwise elsewhere in this RFP:

- AASHTO LRFD Bridge Design Specifications (with exceptions noted in the NCDOT Structures Management Unit Manual)
- NCDOT *Structures Management Unit Manual* (including Policy Memos)
- NCDOT *LRFD Driven Pile Foundation Design Policy*
- NCDOT *Bridge Policy Manual*
- NCDOT *Structures Management Unit Standard Drawings*
- NCDOT *Structures Management Unit Project Special Provisions*

HYDRAULICS SCOPE OF WORK~~(12-14-18)~~ 1-10-19**1 GENERAL****1.1 Design Team Qualification**

The Design-Build Team's hydraulic design firm(s) shall be on the NCDOT's list of firms qualified to perform all hydraulic design work required under this contract. The firm must be prequalified for Tier II hydraulic design work under NCDOT's normal prequalification procedures prior to the Technical Proposal submittal date.

1.2 Pre-Design Meeting

The Design-Build Team shall hold a pre-design meeting with NCTA, and the NCDOT Hydraulics Review Engineer upon NCTA's acceptance of the Preliminary Roadway Plans developed by the Design-Build Team.

2 PROJECT SCOPE**2.1 Project Specific Details**

- 2.1.1 Direct connections from impervious surfaces to the receiving waters shall be minimized to the maximum extent practicable.
- 2.1.2 The Design Build Team shall carry out all drainage related activities as contained in the Biological Assessment of Potential Impacts to Federally Listed Species (December 2017 and January 2018) and the Biological Opinion (April 2018).
- 2.1.3 All hydraulic design shall be in accordance with North Carolina *Design Standards in Sensitive Watersheds* throughout the project limits.
- 2.1.4 At all stream crossings and pipe inlets and outlets in permitted areas, the Design-Build Team shall photograph (in JPG format) the pre and post construction site conditions between each pipe inlet/outlet and the outer limits of the right of way or easement. The Design-Build Team shall also document the existing and final cross sections of streams within the aforementioned limits. The photographs and cross sections shall be labeled by location, compiled into one document, and electronically submitted to NCTA.

3 DESIGN REQUIREMENTS**3.1 Storm Drainage System Design**

- 3.1.1 The Design-Build Team shall design all storm drainage systems using Geopak Drainage, including but not limited to incorporating discharges from allowable routing programs.
- 3.1.2 Raised median island cuts will not be allowed, except at locations as may be incorporated into in the R-2721A Right of Way Plans provided by the Department
- 3.1.3 All drainage system improvements shall be contained within the right of way. When tying directly to existing downstream systems outside the right of way, and those downstream systems are found to be hydraulically deficient during the design storm, the Design-Build Team shall provide an OTCB or 2GI within the right of way limits.
- 3.1.4 Open-ended Berm Drainage Outlets on cut slopes greater than 12 ft. in height are not permitted. Instead, an OTCB inlet structure shall be used.

- 3.1.5 The Design-Build Team shall use a minimum ditch grade of 0.3%. The Design-Build Team shall avoid constructing ditches in wetlands.
- 3.1.6 Drainage elements along the mainline shall be designed appropriately to accommodate an additional future median lane in each direction per the *Roadway Scope of Work*.
- 3.1.7 At a minimum, the Design-Build Team shall install traffic bearing grated drop inlets with steel frames and flat steel grates at the following locations:
- Within a temporary travel lane
 - Within four feet of a temporary and / or permanent travel lane.
- 3.1.8 The Design-Build Team shall provide additional outlet protection at all pipe outlets with a ten-year partial flow velocity greater than 15 fps. The aforementioned outlet protection shall mitigate erosive velocities to receiving downstream channels.

3.2 Hydraulic Spread

- 3.2.1 The hydraulic spread shall not encroach into any operational lane beyond the limits noted below:
- For roadways, the hydraulic spread shall not exceed the values specified in Table 10-1 of the current North Carolina Division of Highways Guidelines for Drainage Studies and Hydraulics Design (2016).
 - For bridges on alignments with design speeds greater than 45 mph, the hydraulic spread shall not encroach into an operational permanent or temporary through lane. In cases where a fourteen (14) foot outside shared lane is specified, the hydraulic spread shall not encroach more than two (2) feet into an operational permanent or temporary through lane.
 - For bridges on alignments with design speeds less than or equal to 45 mph, the hydraulic spread shall not encroach more than four (4) feet into an operational permanent or temporary through lane.
 - Along exclusive turn lanes on bridges, the hydraulic spread shall not encroach more than four (4) feet into the turn lane.
 - For bridges that are specified in the *Structures Scope of Work* to have future sidewalk, the drainage design shall account for future conditions with sidewalk such that all applicable spread requirements are met without the need for future structure widening.

3.3 Bridge Drainage

- 3.3.1 The Design-Build Team shall analyze spread for all bridges identified in the *Structures Scope of Work* found elsewhere in this RFP and, as necessary, provide mitigation that adheres to the hydraulic spread requirements noted above. If required, the Design-Build Team shall adhere to the bridge drainage system requirements noted below:
- 3.3.2 The Design-Build Team shall design bridge drainage without the use of Bridge Scuppers (open grated inlets). If deck drains are used on the bridge, they shall be vertical pipes at the flow line through the deck with no elbow and shall be consistent with that shown in the current NCDOT Stormwater Best Management Practices Toolbox. Closed drainage

systems will be allowed, but only to the extent required through the permitting process. In such case, the closed drainage system shall use vertical pipes at the flow line through the deck with no elbow and shall be consistent with that shown in the current NCDOT Stormwater Best Management Practices Toolbox.

- 3.3.3 The Design-Build Team shall use 4" deck drains adjacent to pedestrian facilities.
- 3.3.4 The Design-Build Team shall provide bridge drainage features that prevent direct discharge into waterways or onto any existing/future greenway, railway right of way, travel lanes or paved shoulders.
- 3.3.5 Unless otherwise required to satisfy this Scope of Work, the maximum allowable deck drain spacing shall be 12-foot on center.

3.4 Hydroplaning Analysis

- 3.4.1 Excluding areas that the Design-Build Team will be uniformly overlaying the existing pavement structure, the Design-Build Team shall perform a hydroplaning risk assessment and, as necessary, provide mitigation that minimizes hydroplaning risk for all new and existing roadways within the construction limits. (Reference the *Roadway and Pavement Management Scopes of Work* found elsewhere in this RFP.) The Design-Build Team shall include a brief summary of the hydroplaning risk assessment as part of the Technical Proposal.
- 3.4.2 The Design-Build Team shall utilize one of the following methods to perform the hydroplaning risk assessment:
 - *Hydraulic Engineering Circular 22*, 3rd Edition, 2009
 - *AASHTO Highway Drainage Guidelines*, 2007
 - *AASHTO Drainage Manual*, 2014
 - *GDOT Drainage Design for Highways*, 2017
 - *FDOT Hydroplaning Risk Analysis Design Guidance*, HP Program, 2014
- 3.4.3 The Design-Build Team shall give particular attention to areas with zero superelevation in a crest and/or sag vertical curve, and superelevation reversal points.
- 3.4.4 The Design-Build Team shall develop a Final Design Hydroplaning Risk Assessment Report that shall be included with the Preliminary Roadway Plans submittal for the Turnpike Authority's review and acceptance.
- 3.4.5 In addition to Final Design Hydroplaning Risk Assessment Report, the Design-Build Team shall develop a Construction Hydroplaning Risk Assessment and Mitigation Plan Report that shall be included with the Traffic Control Plans submittal for the Turnpike Authority's review and acceptance. The aforementioned Report shall identify a process that evaluates and avoids concentrated flow across travel lanes where speeds are in excess of 45 mph during construction phasing. (Reference the *Transportation Management Scope of Work* found elsewhere in this RFP.)

3.5 Stormwater Management

3.5.1 In accordance with the NCDOT Stormwater Best Management Practices Toolbox and the NCDOT Post-Construction Stormwater Program, effective on the Technical Proposal submittal date, the Design-Build Team shall develop a Stormwater Management Plan that, at a minimum, demonstrates the following:

- To the maximum extent practicable, stormwater runoff shall be diverted away from surface waters.
- To the maximum extent practicable, on-site stormwater control measures shall be employed to minimize water quality impacts.
- Underground detention will not be allowed. No additional right of way will be acquired solely for stormwater management.

3.5.2 In accordance with the *Guidelines for Drainage Studies and Hydraulics Design*, including all addenda, memos and revisions, the Design-Build Team shall prepare Outlet Analyses for the increases in discharge due to the proposed project and take appropriate action to ensure that any increases are appropriately mitigated. Such mitigation measures shall first consider long-term maintenance of the proposed mitigation. Except as otherwise noted, improvements to receiving channels shall be implemented prior before implementing any basin type structures.

3.6 Drainage Structures

3.6.1 Throughout this RFP, the term *drainage structures* includes box culverts, cross pipes and storm drainage systems.

3.6.2 The Design-Build Team shall replace all existing metal pipes within the project construction limits with the appropriate pipe type.

3.6.3 The Design-Build Team shall develop discharges for all drainage structures based upon the future build-out land use projections. At a minimum, the Design-Build Team shall use a level of future urbanization with a percent impervious area based on the future land use Wake County/municipal zoning maps and shall be no less than 25% throughout the project. The Design-Build Team shall not include the effects of storage when computing discharges for hydraulic design and analysis for areas less than 50% impervious and/or areas without storm drainage systems. For drainage areas where impervious surfaces are greater than 50% and/or areas with storm drainage systems, routing will be allowed. EPA SWMM, USACE HMS, Win TR-20, HydroCAD or equivalent are acceptable programs for routing. A storm drainage duration of 24 hours shall be used in developing the hydrograph.

This requirement does not apply to any structure for which the Department has submitted a CLOMR, or has provided approved Culvert Survey Reports during procurement of this project and the Design-Build Team's design does not alter the applicable culvert.

3.6.4 Revise the *Guidelines for Drainage Studies and Hydraulic Design* as follows:

- (1) Table 7-2, Peak Discharge Method Selection
 - (A) Rational Method is acceptable up to 80 acres.

- (B) Delete the NCDOT Hwy. Hydrologic Charts column
- (2) Delete Appendix C - NCDOT Hydrologic Charts
- (3) Table 7-1, Design Frequency
- (A) Replace the 50 year frequency for Bridges, Culverts and Cross Pipes (along the mainline) with a 100 year frequency. This requirement does not apply to any structure for which the Department has submitted a CLOMR during procurement of this project and the Design-Build Team's design does not alter that structure's size.
- (B) Replace the 50 year frequency for Storm Drain System at Sags (without relief, along the mainline) with a 100 year frequency.
- (4) Section 15.6 Temporary Encroachment in Regulatory Floodway
- (A) Section 15.6 is not applicable on this project. The Design-Build Team shall assume all liability for any flood damages resulting from the temporary encroachment.
- 3.6.5 For all existing and proposed box culverts and pipes (including all extensions), a minimum 1.5-foot freeboard shall be required below the shoulder point during the design storm. The Design-Build Team shall not steepen slopes, reduce easements and/or reduce right of way solely to obtain the aforementioned freeboard requirement.
- 3.6.6 A maximum $HW/D = 1.2$ shall be not be exceeded for all existing and proposed box culverts and pipes (including all extensions) during the design year.
- 3.6.7 All existing and proposed storm drainage systems shall maintain a hydraulic grade line that is a minimum of 0.5 feet below the inlet rim elevation or top of junction box; and shall adhere to all other requirements as identified in Chapter 10 of the *Guidelines for Drainage Studies and Hydraulic Design*.
- 3.6.8 Cross drainage shall be conveyed with a single drainage structure (pipe or box culvert). Multiple lines of pipe, supplemental pipes, and / or more than three (3) box culvert barrels serving the same watershed shall not be permitted, except that four (4) barrel box culverts are permitted in those locations shown in the Roadway Plans provided by the NCTA.
- 3.6.9 In the Technical Proposal, Volume II, the Design-Build Team shall provide a *Box Culverts and Cross Pipes Hydraulic Assessment Table* that contains the attributes noted below for all new location box culverts and cross pipes 18" in diameter or greater:
- Station
 - Proposed drainage structure details
 - Drainage Area
 - Percent Impervious or "C" value used
 - Built-Out Discharges (Design Year and 100 Year)
 - FEMA Crossing (Yes/No)
 - Water Surface Elevation Natural Condition
 - Water Surface Elevation with Drainage Structure
 - HW/D for Build-out Discharges
 - Hydraulic Freeboard for Build-out Discharges

- Comments

- 3.6.10 The maximum pipe diameter to be used is 60 inches under the mainline, ramps, and loops. Unless otherwise shown on the Roadway Plans provided by the NCTA, the minimum barrel height for any box culvert (inside dimension) shall be 8 feet. The minimum barrel width for any box culvert (inside dimension) shall be 6 feet.
- 3.6.11 Unless noted otherwise elsewhere in this RFP, the Design-Build Team shall remove or fill with flowable fill all pipes not retained for drainage purposes.
- 3.6.12 Throughout the project limits, the Design-Build Team shall analyze all drainage structures for hydraulic and structural deficiencies that are located within the existing / proposed right of way. The Design-Build Team will not be required to analyze drainage structures within -Y- line construction limits that consist solely of pavement marking obliterations/revisions. Using the hydraulic discharges for the future build-out land use projections, drainage structures that do not adhere to the requirements in Sections 9.5.1.3 and 9.5.2.3 of the *Guidelines for Drainage Studies and Hydraulic Design*, including all addenda, memos and revisions, and/or the freeboard, backwater, and HW/D requirements noted above, shall be deemed hydraulically deficient. Based on these analyses, the following shall be adhered to:
- 3.6.13 Based on the above analyses, the Design-Build Team shall provide the appropriate hydraulic mitigation for 1) all hydraulically deficient drainage structures and 2) all hydraulically and structurally deficient drainage structures, including but not limited to replacement. For major hydraulic crossings (crossings with a conveyance greater than or equal to the capacity of a single 60-inch diameter pipe), the Design-Build Team shall 1) remove all hydraulically, or hydraulically and structurally, deficient box culvert(s) and/or pipe(s), and 2) replace the aforementioned box culvert(s) and/or pipe(s) with a box culvert unless noted otherwise elsewhere in this RFP. Inlet improvements outside the right of way shall not be allowed to mitigate for hydraulically deficient box culverts and / or pipes. Based on build-out discharges, the Design-Build Team shall identify all hydraulically deficient drainage structures and note their proposed mitigation in the Technical Proposal. At a minimum, in the Technical Proposal, Volume II, the Design-Build Team shall 1) identify all hydraulically deficient storm drainage systems and the proposed mitigation on the plans, and 2) provide a *Box Culverts and Cross Pipes Hydraulic Deficiency Assessment and Proposed Mitigation Table* that contains the box culvert and cross pipe attributes noted below:
- Station
 - Existing Box Culvert/Cross Pipe Details
 - Drainage Area
 - Percent impervious or “C” value used
 - Build-out Discharges (Design year and 100 year)
 - Hydraulically Deficient (Yes/No) for Build-out Discharges
 - Proposed Mitigation Structure(s) Details
 - HW/D for Build-out Discharges at Existing Structure without Mitigation
 - HW/D for Build-out Discharges at Existing Structure with Mitigation

- Hydraulic Freeboard at Sag for Build-out Discharges at Existing Structure without Mitigation
 - Hydraulic Freeboard at Sag for Build-out Discharges at Existing Structure with Mitigation
 - HW/D for Build-out Discharges for Mitigation Structure(s)
 - Hydraulic freeboard at Sag for Build-out Discharges at Mitigation Structure(s)
 - Comments
- 3.6.14 To ensure that all pipes and box culverts that are retained for drainage purposes are structurally sound, the Design-Build Team shall provide appropriate documentation obtained from video inspections for the Turnpike Authority's review and approval prior to any hydraulic design submittal. Prior to performing any storm drain clean-out required for the aforementioned video inspections, the Design-Build Team shall obtain approval from the Engineer. In accordance with Subarticle 104-8(A) of the 2018 NCDOT *Standard Specifications for Roads and Structures*, required storm drain clean-out will be paid for as extra work.
- 3.6.15 As directed by the Engineer, the Design-Build Team shall provide the appropriate structural mitigation for all structurally deficient box culverts and/or pipes. Structural mitigation, for structural deficiencies in box culverts and/or pipes, including but not limited to, all repairs and replacement will be paid for as extra work in accordance with Subarticle 104-8(A) of the 2018 NCDOT *Standard Specifications for Roads and Structures*.
- 3.6.16 All proposed drainage boxes, including but not limited to catch basins, drop inlets and junction boxes, shall have a grate or manhole access.
- 3.6.17 For pipe inlets and outlets in jurisdictional areas, the Design Build Team shall install countersunk rip rap pads, with underlying geotextile at these inlets and outlets. The rip rap pads and geotextile shall extend a minimum of 10 feet from pipe inlets and a minimum of 20 feet from pipe outlets or to the length of construction disturbance, whichever is greater. If Triassic material is encountered at the inlet or outlet, the rip rap pad and geotextile shall extend to the above minimums or to the length of the construction disturbance, whichever is greater.
- 3.6.18 For outlet protection for pipes greater than or equal to 36" in diameter and sloped steeper than 1%, use the applicable Class riprap as noted below:
- 36" \leq pipe diameter < 48" Class I
 - 48" \leq pipe diameter Class II

4 PERMIT COORDINATION AND FEMA REGULATED STREAMS

4.1 Permit Modification

The Design-Build Team shall follow the Section 6002 Coordination Plan for the project and shall conduct an Interagency Meeting as described in the *Environmental Permits Scope of Work* found elsewhere in this RFP. All work resulting from the Interagency Meeting(s) shall be the Design-Build Team's responsibility. A minimum of five weeks prior to the appropriate Interagency

Meeting, the Design-Build Team shall provide 1) hydraulic plans and 2) permit drawings, calculations, and impact sheets for the USACE 404 Permit and the NCDWR Section 401 Certification to the Turnpike Authority. The Design-Build Team shall take minutes of the Interagency Meetings and provide them to the Turnpike Authority within three business days of the aforementioned meetings.

4.2 FEMA Regulated Streams

For all FEMA regulated streams impacted by the Design-Build Team's design and/or construction, the Design-Build Team shall adhere to the current *Guidelines for Drainage Studies and Hydraulics Design*, including all addenda, memos and revisions, and the following requirements:

- 4.2.1 The Department has initiated the CLOMR process for this project and will provide any CLOMRs or MOAs when they are approved. The Design-Build Team shall prepare revised CLOMR or MOA packages for the Turnpike Authority's submittal to the North Carolina Floodplain Mapping Program (NCFMP) if needed based on their final design. The Design-Build Team shall obtain NCFMP approval prior to performing any construction activity in a FEMA regulated floodplain.
- 4.2.2 In the unlikely event that the Design-Build Team's hydraulic design does not require a change to the structure size, and the CLOMR is not issued based on the Department's design, then the design and construction costs associated with modifying the structure size will be paid as Extra Work in accordance with Article 104-8(a) of the Standard Specifications for Roads and Structures.
- 4.2.3 For any new CLOMRs, any increase in 100-year water surface elevation that occurs between the Corrected Effective and Revised Conditions models shall be limited to no more than 0.5 feet. For any revised CLOMRs, any increase shall be limited to no greater than what was previously contained in the CLOMR prepared by the Department. When a CLOMR or MOA is required, the Design-Build Team shall use the preliminary FIS model in lieu of the effective model for Wake County.
- 4.2.4 The Design-Build Team shall notify the Turnpike Authority, in writing, of all structures that may require purchase due to an increase in the 100-year water surface elevation. The Turnpike Authority will be responsible for all surveys to ascertain insurable structures within the impacted area of the floodplain(s). The Design-Build Team shall discuss the extent and limits of the rise in water elevation in the floodplain(s), identify potentially impacted insurable structures, specify areas anticipated to require additional surveys and estimate the anticipated additional right of way impacts outside the project construction limits in the Technical Proposal. (Reference the *Right of Way Scope of Work* found elsewhere in this RFP.)
- 4.2.5 The Turnpike Authority will be responsible for all fees associated with the CLOMR(s) and/or MOA(s).
- 4.2.6 The Design-Build Team shall ensure that construction and/ removal of all structures in FEMA regulated floodplains adheres to the approved CLOMR(s) and/or MOA(s). Within three months of completion of work in a FEMA-regulated floodplain, the Design-Build Team shall provide As-Built Plans of the site, and a completed As-Built Certification Review Form that verifies construction adheres to the approved CLOMR(s) and/or MOA(s).

- 4.2.7 The Design-Build Team shall prepare a new FEMA model and/or package and be responsible for all associated costs resulting from any construction variation from the approved CLOMR(s) and/or MOA(s).
- 4.2.8 The Turnpike Authority will allow no direct contact between the Design-Build Team and the NCFMP representatives. No contact between the Design-Build Team, the NCFMP and/or personnel under contract with NCFMP shall be allowed by phone, e-mail, or in person, without NCDOT representatives present. A representative from the Turnpike Authority shall be included on all correspondence.
- 4.2.9 Temporary impacts due to construction and/or on-site detour traffic that 1) last longer than one year and/or 2) encroaches into the floodway, shall be reviewed by the Design-Build Team for changes in the water surface elevations that could impact structures or have adverse impacts to the surrounding property. The results of the review shall be submitted to the Hydraulic Unit in a report format for the Turnpike Authority's coordination with NCFMP.

5 PRINCIPLE STANDARDS

Perform all work in accordance with the latest publication of the following effective on the Technical Proposal submittal date, including all revisions, errata, addenda, etc., effective on the Technical Proposal submittal date unless noted otherwise elsewhere in this RFP:

- NCDOT *Best Management Practices for Construction and Maintenance Activities*
- NCTA *Design-Build Submittal Guidelines*
- NCDOT *Guidelines for Drainage Studies and Hydraulics Design, excepted as may be amended herein*
- NCDOT Hydraulics Unit website:
<https://connect.ncdot.gov/resources/hydro/pages/default.aspx>
- NCDOT *Post-Construction Stormwater Program*
- NCDOT *Stormwater Best Management Practices Toolbox*

In case of conflicting design parameters, and/or ranges, in the various resources, the proposed design shall adhere to the most conservative values, unless noted otherwise elsewhere in this RFP.

GEOTECHNICAL ENGINEERING SCOPE OF WORK

(11-7-18)

1. GENERAL**1.1. Private Firm Requirements**

- 1.1.1. Obtain the services of a firm prequalified for geotechnical work by the NCDOT Geotechnical Engineering Unit at:

<https://www.ebs.nc.gov/VendorDirectory/search.html?s=fn&a=new>

- 1.1.2. The prequalified geotechnical firm shall prepare foundation design recommendation reports for use in designing structure foundations, roadway foundations, retaining walls, sound barrier foundations, and overhead sign structure foundations, and temporary structures.
- 1.1.3. The Engineer of Record who prepares the foundation design recommendation reports shall be a Professional Engineer registered in the State of North Carolina who has completed a minimum of three geotechnical design projects of scope and complexity similar to that anticipated for this project using the load and resistance factor design (LRFD) method and in accordance with the latest edition of the AASHTO *LRFD Bridge Design Specification*.
- 1.1.4. The prequalified geotechnical firm shall also determine if additional subsurface information, other than that required and noted elsewhere in this RFP, is required based upon the subsurface information provided by the NCDOT and the final roadway and structure designs. If a determination is made that additional subsurface information is required, the Design-Build Team shall use a prequalified geotechnical firm to perform all additional subsurface investigation and laboratory testing in accordance with the current NCDOT Geotechnical Engineering Unit *Guidelines and Procedures Manual for Subsurface Investigations*. Submit additional information collected by the Design-Build Team to the Geotechnical Engineering Unit, via the Design-Build Unit, for review and acceptance. The Design-Build Team shall provide the final Subsurface Investigation report in electronic and hardcopy format to the NCTA for its records.

1.2. Borings

- 1.2.1. A minimum of 2 standard penetration test (SPT)/rock core borings shall be required per bent for all bent lengths of 50 feet or less. Additional SPT/rock core borings shall be required across the roadway typical section for each bent more than 50 feet long and the borings shall be spaced no greater than 50 feet apart. All borings for pile-supported bents shall be located within 25 feet of the centerline of each bent location to be counted for these minimum requirements. All borings for bents with spread footing or drilled pier foundations shall be performed at opposite ends of each bent, or no greater than 50-foot spacing along the bent line as required by bent length noted above, to be counted for these minimum requirements. For structure sites with multiple bridges, borings may be performed between bridges along the bent projection provided the distance between any two borings does not exceed 50 feet.

- 1.2.2. The Design-Build Team shall extend all borings to a depth of 15 feet or four foundation element diameters, whichever is greater, below the foundation element to show a complete subsurface profile. The Design-Build Team shall be responsible for obtaining the borings noted above for all bents where subsurface information is not sufficient or is warranted by variability in the geology unless the prequalified geotechnical firm submits documented justification that the subsurface investigation provided by the NCDOT is adequate for design purposes and the justification is acceptable to the Department. Any deviations to the requirements noted above shall require acceptance from the NCDOT Geotechnical Engineering Unit prior to the foundation design submittal.
- 1.2.3. The maximum spacing between borings for retaining walls and sound barrier walls shall be 100 feet, with a minimum of two borings; one at each end of the wall. Drill borings for retaining walls a minimum depth below the bottom of the wall equal to twice the maximum wall height. Boring depths for sound barrier walls shall be to a minimum depth below the bottom of the wall equal to the maximum wall height, SPT refusal, or auger refusal, provided the Geotechnical Engineer is certain that refusal is due to a true rock layer and not an isolated boulder or cobble.

1.3. Triassic Rock

- 1.3.1. This project is located in the vicinity of the Triassic Basin consisting of sandstone, siltstone, and mudstone. These sedimentary rocks were formed during the Triassic Age and consist of irregularly bedded sandstone, siltstone, and mudstone; partly micaceous and feldspathic in composition. Triassic soils have high slaking potential and degrade when exposed to air and/or water. Degradable rock is defined as hard rock material which exhibits high slaking characteristics when exposed to air and water. This type material is anticipated on this project and is comprised of Triassic mudstone and siltstone.
- 1.3.2. Borrow material or unclassified excavation containing Triassic soil shall not be used on the project.

2. BRIDGE AND ROADWAY FOUNDATIONS

2.1. Principle Standards

- 2.1.1. Unless noted otherwise herein, the Design-Build Team shall design foundations (except for sign foundations), embankments, slopes, retaining walls, and sound barrier walls in accordance with the current edition of the AASHTO *LRFD Bridge Design Specifications*, NCDOT *LRFD Driven Pile Foundation Design Policy*, all applicable NCDOT Geotechnical Engineering Unit Standard Provisions, NCDOT *Structures Management Unit Manual* and NCDOT *Roadway Design Manual*. The NCDOT *LRFD Driven Pile Foundation Design Policy* is located on the NCDOT Geotechnical Engineering Unit's website at:

<https://connect.ncdot.gov/resources/Geological/Pages/default.aspx>

- 2.1.2. For *Geotechnical Guidelines For Design-Build Projects*, the Design-Build Team shall adhere to the guidelines located at the following website:

<https://connect.ncdot.gov/letting/Pages/Design-Build-Resources.aspx>

2.2. Structure Foundations

- 2.2.1. At grade crossings, key spread footings at least 12” into weathered rock. At stream crossings, key footings full depth into crystalline rock and provide scour protection in accordance with scour protection detail in the NCDOT *Structures Management Unit Manual*. Do not use spread footings on soil or on MSE wall backfill.
- 2.2.2. Permanent steel casings shall be required for drilled piers that are constructed in six inches or more of water. Permanent steel casings shall be required for drilled piers constructed on sloped stream banks subject to degradation from flooding.
- 2.2.3. When the weathered rock or rock elevation is below the 100-year hydraulic scour elevation, the 100-year and 500-year design scour elevations are equal to the 100-year and 500-year hydraulic scour elevations from the structure survey report developed by the Design-Build Team and accepted by the NCDOT Hydraulics Unit. When the weathered rock or rock elevation is above the 100-year hydraulic scour elevation, the 100-year design scour elevation may be considered equal to the top of the weathered rock or rock elevation, whichever is higher, and the 500-year design scour elevation may be set two feet below the 100-year design scour elevation.
- 2.2.4. End bent fill slopes up to 35 feet in height (defined as the difference between grade point elevation and finished grade at toe of slope) shall be 1.5:1 (H:V) or flatter. End bent fill slopes with heights greater than 35 feet shall be 2:1 or flatter. All end bent cut slopes shall be 2:1 or flatter. For 1.5:1 fill slopes, extend end bent slope protection from the toe of slope to berm and to 1.75:1 (H:V) slope. For end bent cut slopes and for 2:1 or flatter end bent fill slopes, extend end bent slope protection from the toe of slope to berm and to the limits of the superstructure.
- 2.2.5. Analyze drilled pier and pile bent foundations using either L-Pile or FB-Pier. Design drilled piers and vertical piles in pile bents with a sufficient embedment in soil and/or rock to achieve “fixity”.
- 2.2.6. For box culverts, the Design-Build Team shall submit details for undercut of unsuitable material or recommendations for use of more than one foot of conditioning material to the NCDOT Geotechnical Engineering Unit, via the Design-Build Unit, for review and acceptance.
- 2.2.7. The Design-Build Team is permitted to design bridges on this project using software that accounts for the structural effects of soil/pier interaction.
- 2.2.8. Add steel pile points to all piles with an estimated embedded length of 20’ or less unless drilled into rock.

2.3. Roadway Foundations

- 2.3.1. The Design-Build Team shall not provide fill or cut slopes that are steeper than those stipulated in the recommendations provided by the Department and as shown in the Roadway Right of Way Plans. Unless noted otherwise herein, all other unreinforced proposed fill slopes, except bridge end bent slopes (Reference Section 2.2), shall be 2:1 (H:V) or flatter. Unless the slopes are designed with adequate reinforcement to provide the required stability, all other proposed soil cut slopes shall be 2:1 (H:V) or flatter. Except as allowed below, rock cuts (SPT: minimum 60 blows per inch) shall be 1:1 (H:V) or flatter. Reinforced soil slopes shall only be used if detailed design calculations and a slope stability analysis are submitted to the NCDOT Geotechnical Engineering Unit, via the Design-Build Unit, for review and acceptance prior to construction.
- 2.3.2. Reinforced soil fill slopes shall only be used to minimize impacts to existing structures, and/or cultural, historical or otherwise protected landmark or topographic features.
- 2.3.3. Design and construct bridge approach fill (embankments within 100' of the ends of a bridge) such that no more than ½-inch of settlement occurs after the waiting period or settlement monitoring ends. Design and construct roadway embankments such that no more than 2" of settlement occurs after the waiting period or settlement monitoring ends. Long term settlement calculations for estimating settlement magnitude and the wait times necessary to meet the settlement limits above shall account for both primary and secondary consolidation. Do not begin any waiting period until the embankment fill is constructed to subgrade elevation. Soil improvement techniques to mitigate long term settlement problems or to transfer the embankment load to a deeper bearing stratum are allowed. Soil improvement techniques shall follow the current industry standard practices and the guidelines of *Ground Improvement Methods FHWA publication NHI-04-001* or *Geosynthetic Design and Construction Guidelines FHWA-HI-95-038*.
- 2.3.4. Monitor embankment settlement when a waiting period of more than one month for approach fill or two months for roadway embankment is recommended in the foundation design recommendation reports developed by the Design-Build Team.
- 2.3.5. Mitigate all unsuitable soils to the extent that is required to improve the stability of the proposed embankment or subgrade. Use any suitable material to backfill undercut areas except when employing shallow undercut in accordance with Section 505 of the NCDOT 2018 *Standard Specifications for Roads and Structures*, which requires the use of Select Material, Class IV. For undercut backfilling in water, use Select Material, Class III.
- 2.3.6. Class IV aggregate subgrade in lieu of chemical stabilization is not permitted on this project.
- 2.3.7. In all new embankments over 5 feet in height including, but not limited to, a widened embankment section, the Design-Build Team shall add a high strength geotextile (Type 5) in accordance with the *Geotextile for Pavement Stabilization Project Special Provision* found elsewhere in this RFP. If the Design-Build Team elects to use Pavement Alternate

5 (reference *Pavement Management Scope of Work*) for the mainline (or an ABC option for -Y- lines), the geotextile shall be placed immediately beneath the Aggregate Base Course. If the Design-Build Team elects to use Pavement Alternate 1, 2, 3, or 4 for the mainline (or an asphalt base option for -Y- lines), the geotextile shall be placed 12"-18" below the bottom of the asphalt. The geotextile shall extend one foot outside the limits of the pavement structure.

- 2.3.8. In cut sections, a Type 4 geotextile shall be installed in locations where chemical stabilization is not used. The geotextile shall be placed immediately beneath the Aggregate Base Course. The geotextile shall extend one foot outside the limits of the pavement structure.

3. PERMANENT RETAINING WALL STRUCTURES

3.1. MSE Wall Design

For design and construction of mechanically stabilized earth (MSE) retaining walls, refer to the NCDOT *Policy for Mechanically Stabilized Earth Retaining Walls* which can be found at the NCDOT Geotechnical Engineering Unit's website at:

<https://connect.ncdot.gov/resources/Geological/Pages/Products.aspx>

3.2. Permanent Retaining Wall Design

- 3.2.1. With the exception of gravity walls, design and construct permanent retaining walls in accordance with the applicable NCDOT Geotechnical Engineering Unit Project Special Provisions, which can be provided upon request by the Design-Build Team. Geotechnical Provisions and Notes can be found at the NCDOT Geotechnical Engineering Unit's website at:

https://connect.ncdot.gov/resources/Geological/Pages/Geotech_Provisions_Notes.aspx

- 3.2.2. With the exception of gravity walls, submit a wall layout and design for each retaining wall. At a minimum, the wall layout submittal shall include the following:
- Wall envelope with top of wall, bottom of wall, existing ground and finished grade elevations at incremental stations
 - Wall alignment with stations and offsets
 - Typical sections showing top and bottom of wall, drainage, embedment, slopes, barriers, fences, etc.
 - Calculations for bearing capacity, global stability and settlement
 - Details of conflicts with utilities and drainage structures
 - Roadway plan sheets showing the wall (half size)
 - Roadway cross sections showing the wall (half size)
 - Traffic Control Plans showing the wall (half size)

- 3.2.3. Gravity walls shall be designed and constructed in accordance with the NCDOT Structure Standard Drawings and the NCDOT 2018 *Standard Specifications for Roads and Structures*. Gravity walls shall be identified in the roadway foundation design recommendation report developed by the Design-Build Team and accepted by the Department. Cast-in-place cantilever walls shall be designed and constructed in accordance with the 2018 NCDOT *Standard Specifications for Roads and Structures*. Conceptual wall layouts and wall designs shall be submitted to NCDOT for review and acceptance prior to construction.
- 3.2.4. Locate retaining walls at toes of slopes unless restricted by right of way limits. The Design-Build Team shall submit global stability calculations for slopes at retaining walls and obtain acceptance from the NCDOT prior to construction. All slopes behind walls shall be 2:1 (H:V) or flatter. Global stability factors of safety are 1.5 for structures and 1.3 for slopes.
- 3.2.5. Retaining walls or abutment walls will not be allowed at any location where more than five feet of scour is calculated at the base of the wall.
- 3.2.6. Drainage over the top of retaining walls shall not be allowed. Sags in the top of walls shall not be permissible. Direct runoff above and below walls away from walls, if possible, or collect runoff at the walls and transmit it away. Curb and gutter or cast-in-place single faced barrier with paving up to the wall shall be required when runoff cannot be directed away from the back or front of the wall. In accordance with the NCDOT Roadway Design Manual – Section 6-7A, Figure 3, the Design-Build Team shall design and construct a paved concrete ditch, with a minimum 12-inch depth, at the top of all retaining walls with slopes draining towards the wall, and a four-foot bench between the wall and fill/cut slopes steeper than 6:1 (H:V).
- 3.2.7. Precast or cast-in-place coping shall be required for walls without a cast-in-place face with the exception of when a barrier is integrated into the top of the wall. Extend coping or cast-in-place face a minimum of 6 inches above where the finished or existing grade intersects the back of the wall.
- 3.2.8. For all proposed walls and existing walls to be retained, a fence or handrail shall be required on top of the facing, coping or barrier or immediately behind the wall, if there is no slope behind the wall.
- 3.2.9. When using abutment retaining walls with deep foundations, the end bent deep foundation shall be designed and constructed with one of the following: (1) a single row of plumb piles with brace piles battered toward the wall, (2) a single row of plumb piles with MSE reinforcement connected to the back of the cap, (3) integral abutment with a single row of plumb piles and no reinforcement connected to the back of the cap in accordance with FHWA GEC 11 pages 6-8 through 6-10, or (4) drilled piers. The abutment wall shall be designed to satisfactorily resist the additional loading from the foundation(s). All deep foundations for end bents with abutment retaining walls shall extend a minimum of ten feet below the retaining wall foundation or leveling pad. For

drilled-in piles behind such retaining walls, the penetration can be reduced to five feet below the bottom of the wall provided the Design-Build Team analyzes and determines that the vertical piles are “fixed” in natural ground such that the decrease in pile embedment shall not significantly increase the top deflection under lateral loading. The calculations and supporting documentation for this analysis shall be submitted to the NCDOT for review and acceptance prior to construction.

4. TEMPORARY STRUCTURES

4.1. Temporary Retaining Structure Design

Design temporary retaining structures, which include earth retaining structures and cofferdams, in accordance with current allowable stress design AASHTO *Guide Design Specifications for Bridge Temporary Works*, the *Temporary Shoring Standard Special Provision* found elsewhere in this RFP and the applicable NCDOT Project Special Provisions available upon request by the Design-Build Team. The only submittal required to use the standard sheeting design is the “Standard Shoring Selection Form”.

4.2. Traffic Control Barrier

Traffic control barrier on top of walls shall be in accordance with the NCDOT Work Zone Traffic Control Unit details available upon request by the Design-Build Team. If anchored barrier is required, then anchor the barrier in accordance with 2018 NCDOT Roadway Standard Drawing No. 1170.01.

5. CONSTRUCTION REQUIREMENTS

5.1. Construction Standards and Remedial Measures

5.1.1. All construction and materials shall be in accordance with the NCDOT 2018 *Standard Specifications for Roads and Structures* and current NCDOT Project Special Provisions, unless stated otherwise elsewhere in this Scope of Work. The Design-Build Team shall investigate, propose and incorporate remedial measures for any construction problems related to the following:

- Foundations
- Retaining Walls
- Sound Barrier Walls
- Subgrades
- Settlement
- Slopes
- Construction Vibrations

5.1.2. The Design-Build Team shall be responsible for any damage and/or claim caused by construction, including but not limited to damage caused by vibration (see Article 107-14 of the 2018 *NCDOT Standard Specifications for Roads and Structures*). The Design-Build Team shall be responsible for deciding what, if any, pre- and post-construction

monitoring and inventories need to be conducted to satisfy their liability concerns. Any monitoring and inventory work shall be performed by a prequalified private engineering firm experienced in the effects of construction on existing structures.

- 5.1.3. Conduct proofrolling in accordance with Section 260 of the 2018 NCDOT *Standard Specifications for Roads and Structures*.

5.2. Engagement of Geotechnical Firm During Construction

- 5.2.1. The prequalified geotechnical firm that prepared the foundation designs shall review the settlement monitoring data a minimum of once a month and issue a letter prior to releasing the approach fill or roadway embankment from monitoring. Monitoring shall not end until less than 0.10 inch (approach fill) or 0.25 inch (roadway embankment) of settlement is measured over a period of four weeks. Submit the settlement monitoring data to the Design-Build Unit prior to issuing the release letter.
- 5.2.2. The prequalified geotechnical firm that prepared the foundation designs shall review and approve all pile driving hammers and drilled pier construction sequences. After the prequalified geotechnical firm has approved these submittals, the Design-Build Team shall submit to the NCDOT for review and acceptance prior to beginning construction.
- 5.2.3. The prequalified geotechnical firm that prepared the original foundation designs shall perform any changes to the foundation designs. All changes shall be based upon additional information, subsurface investigation and/or testing. Send copies of revised designs, including additional subsurface information, calculations and any other supporting documentation, sealed by a professional engineer registered in the State of North Carolina, to the NCDOT for review and acceptance.

5.3. Driven Piles

- 5.3.1. Install piles in accordance with Section 450 of the 2018 NCDOT *Standard Specifications for Roads and Structures* and the *Piles Project Special Provision* located on the NCDOT Geotechnical Engineering Unit's website. Prequalification of contractors is not required for pile excavation or drilled-in pile holes that are 30 inches in diameter or less. Class A concrete or grout shall be required to backfill holes for drilled-in piles.
- 5.3.2. Prior to Pile Driving Analyzer (PDA) testing, perform hammer approvals with GRLWEAP Version 2002 or later and in accordance with the NCDOT LRFD Driven Pile Foundation Design Policy.
- 5.3.3. Perform PDA testing, provide PDA reports, and develop pile driving inspection charts or tables in accordance with Section 450 of the 2018 *Standard Specifications for Roads and Structures* and the *Piles Project Special Provision* located on the NCDOT Geotechnical Engineering Unit's website, except that pile driving inspection charts or tables may be provided by the PDA consultant or the foundation design engineering firm. For each permanent bridge that includes driven pile bents or driven pile footings, perform a minimum of one (1) PDA test (dual bridges are counted as one structure) for each pile

size, pile type (material or shape) and pile driving hammer combination. Additional PDA tests may be required based upon the AASHTO *LFRD Bridge Design Specifications*. If the bridge length with driven pile foundations is longer than 400 feet, perform an additional PDA test at every 400-foot interval. Provide additional PDA testing for any revisions to pile type, size or hammer previously approved. The locations of specific piles to be tested must be accepted by the NCDOT prior to any PDA test.

5.4. Drilled Piers

- 5.4.1. Use current NCDOT inspection forms for drilled piers available on the NCDOT Geotechnical Engineering Unit's webpage. Construct and inspect drilled piers in accordance with Section 411 of the 2018 NCDOT *Standard Specifications for Roads and Structures* and the *Drilled Piers* Project Special Provision located on the NCDOT Geotechnical Engineering Unit's website.
- 5.4.2. The Department will inspect drilled piers using the Shaft Inspection Device (SID) for any pours using the wet method of concrete placement and for any drilled pier excavations that cannot be visually inspected or have remained open longer than 24 hours that cannot be dewatered due to unstable soil or rock.
- 5.4.3. The Design-Build Team shall notify Matt Hilderbran, PE by e-mail (mrhilderbran@ncdot.gov) a minimum of five days prior to required SID testing, followed by a confirmation two days prior to required SID testing. The Design-Build Team shall notify Matt Hilderbran of all SID testing cancellations as soon as possible at the e-mail address noted above and at (919) 329-4015.
- 5.4.4. Install Crosshole Sonic Logging (CSL) tubes in all drilled piers. CSL test a minimum of 25% of drilled piers at each bridge or one per bent, whichever is greater. If a CSL test identifies any defect in the drilled pier, the Department has the right to request additional CSL testing as needed. The Department will determine which piers will be CSL tested. Submit CSL test information and results to the Geotechnical Engineering Unit, via the Design-Build Unit, for review and acceptance.
- 5.4.5. Drilled pier tip elevations shall not be changed during construction unless the prequalified geotechnical firm that prepared the bridge foundation design redesigns the drilled pier from either an SPT/rock core boring, performed in accordance with ASTM standards at the subject pier location, or observations of the drilled pier excavation. If a drilled pier is designed based on a boring, do not drill a boring inside an open drilled pier excavation. Locate the boring within three pier diameters of the center of the subject pier and drill to a depth of two pier diameters below the revised tip elevation. If a drilled pier is redesigned based upon observations of the drilled pier excavation, the geotechnical engineer of record shall be present during the excavation to determine the actual subsurface conditions.

5.5. Undercut at Geotechnical Grade Point

The geotechnical grade point shall be defined as the location where the proposed mainline, -Y-lines, service roads, interchange ramps and loops profile of the subgrade and natural ground intersect. At all geotechnical grade points, the Design-Build Team shall undercut the existing soils that are within two feet of the bottom of the proposed subgrade in accordance with the requirements noted below:

- The maximum two-foot undercut depth shall occur at the geotechnical grade point.
- The undercut shall extend along the profile to a point where the elevation difference from the bottom of the proposed subgrade to natural ground is greater than two feet, or to 25 feet on each side of the geotechnical grade point, whichever is less.
- The lateral extent of the undercut shall extend to a point where the elevation difference from the bottom of the proposed subgrade to natural ground is greater than two feet or to one foot outside of the paved shoulder/face of curb of the proposed roadway typical section, whichever is less.
- The base of the undercut shall parallel the proposed subgrade.
- Grade point undercuts can be backfilled with soil that meets Section 235 of the 2018 NCDOT *Standard Specifications for Roads and Structures*.

5.6. General Submittal Information

- 5.6.1. Send copies of any inspection forms related to foundations, settlement, sound barrier walls, or retaining walls to the NCDOT for review.
- 5.6.2. All geotechnical data, tests, computations and supporting subsurface investigations and documentation submitted by the Design-Build Team shall be provided in English Units.

ENVIRONMENTAL PERMITS SCOPE OF WORK

(10-18-18)

1. PERMIT STATUS

The NCTA and the NCDOT are in the process of obtaining a phased US Army Corps of Engineers Section 404 Permit and a phased NC Department of Environmental Quality (NCDEQ), Division of Water Resources (DWR) Section 401 Water Quality Certification and Neuse Riparian Buffer Authorization. These permits will be for the entire corridor from the NC 55 Bypass to US 64/US 264/I-495/I-87. This permit application was submitted on September 12, 2018 and the permit is anticipated to be obtained in January or February 2019. This permit will be based on final impacts for the R-2721A and R-2721B projects, but only preliminary impacts for R-2828 and R-2829. The Complete 540 - Triangle Expressway Southeast Extension corridor-wide permit application may be referenced on the websites noted below:

<http://www.saw.usace.army.mil/Missions/Regulatory-Permit-Program/Public-Notices/>

and

<https://connect.ncdot.gov/resources/Environmental/Pages/default.aspx>

2. CONSTRUCTION PERMITS AND LIMITATIONS**2.1. General Permit Modification Responsibilities**

- 2.1.1. The permits are anticipated to be issued in early 2019 will be final construction permits for R-2721A based on the permit application prepared and submitted by the Department on September 12, 2018. This scope of work outlines the permit modification responsibilities of the Design-Build Team. The Design-Build Team may pursue permit modifications for R-2721A independent of the permitting process for the remainder of the corridor.
- 2.1.2. If modifications to the permits (R-2721A) are necessary to accommodate the Design-Build Team's design (including adjustments to the design to satisfy the requirements of this RFP), construction methods or utility relocations/construction, the Design-Build Team shall be responsible for environmental agency coordination through NCTA and NCDOT and preparing all documents necessary to apply for all permit modifications. The Design-Build Team shall describe in the Technical Proposal those items that are anticipated to require permit modifications.
- 2.1.3. The NCTA will not allow any contract time extensions or additional compensation associated with obtaining permit modifications, public involvement, environmental assessments, additional design effort, additional construction effort and/or additional agency coordination and approvals. Mobilization of personnel, materials, or equipment for site investigation or construction of the project shall not occur in non-permitted jurisdictional areas impacted by design revisions, construction methods, and/or utility relocations/construction prior to obtaining the required permit modifications.

2.2. Activities Prior to Application for Permit Modification

- 2.2.1. NCTA is utilizing a SAFETEA-LU Section 6002 compliant Project Coordination Plan for coordinating with environmental resource and regulatory agencies on this project. This process is being used in lieu of the Merger Process, and while it includes the same general milestones as the Merger Process, written concurrence from agency representatives is not required to advance the project development and permitting process.
- 2.2.2. Depending on the nature of the proposed permit modifications, the Design-Build Team may be required to conduct an additional 4C type meeting to review the revisions or additions to previously permitted sites prior to the NCTA submitting the permit modification application. The Design-Build Team shall follow the appropriate details in the document titled “Project Coordination Plan for the Triangle Expressway Southeast Extension Project” contained in the Appendix A of the Final Stakeholder Involvement Report (December 2017) incorporated as part of the Final EIS as well as the Merger Information website referenced below:

<https://connect.ncdot.gov/resources/Environmental/Pages/Merger.aspx>

- 2.2.3. Any variations from the NCTA’s proposed design and/or construction methods that nullify any previous agreements or decisions reached between NCDOT or NCTA and the environmental agencies and/or require additional coordination with the environmental agencies shall be the sole responsibility of the Design-Build Team. The NCTA will not allow any contract time extensions or additional compensation associated with this additional coordination.

2.3. Limitations on Construction Activities Prior to Permits

- 2.3.1. The Design-Build Team shall not begin ground-disturbing activities in non-permitted jurisdictional areas, including utility relocation, until permit modifications have been issued.
- 2.3.2. The Design-Build Team shall coordinate with the NCTA to determine if a Preconstruction Notification (PCN) is required for the Nationwide Permit No. 6. If a PCN is required, the Design-Build Team shall submit all necessary documents and forms to the NCTA for submittal to the appropriate agencies; and shall not perform any geotechnical investigative work within the jurisdictional resource(s) requiring a PCN prior to obtaining the required approval. If a PCN is not required, the Design-Build Team may proceed with geotechnical investigations inside and outside jurisdictional resources, provided all of the Nationwide Permit No. 6 General Conditions are followed.
- 2.3.3. Unless noted otherwise in this RFP, the Design-Build Team shall be bound by the terms of all signed planning documents, and approved minutes and commitments of all interagency meetings.
- 2.3.4. The Design-Build Team shall be held accountable for meeting all permit conditions. The Design-Build Team shall be required to document that they have adequate staff to monitor

and ensure permit compliance throughout the life of the project prior to the submission of the permit application.

2.4. Permit Modification Application Process

- 2.4.1. It shall be the Design-Build Team's responsibility to acquire information and prepare permit drawings that reflect the impacts and minimization efforts resulting from the agency coordination meetings and from the project as designed by the Design-Build Team. Further, it shall be the Design-Build Team's responsibility to provide these permit impact sheets (drawings) depicting the design and construction details to the NCTA as part of the permit modification application. The aforementioned permit impact sheets shall be submitted to the NCTA for review and acceptance prior to the permit modification application submittal. The Design-Build Team shall be responsible for developing the permit modification application for all jurisdictional impacts. The permit modification application shall include all utility relocations required by the project. At a minimum, the permit modification application shall consist of the following:
- (1) Cover Letter
 - (2) Completed forms (ENG4345, etc.) appropriate for impacts (to be provided by NCDOT, if needed)
 - (3) Minutes from the additional 4C Meetings, if applicable
 - (4) Stormwater Management Plan, if revised
 - (5) Permit drawings with and without contours and, if necessary, utility drawings with and without contours
 - (6) Wetland, stream, and riparian buffer permit impact summary sheets
 - (7) Half-size plans
- 2.4.2. The NCDOT will re-verify and update, as needed, the required environmental data that expires prior to permit issuance. These include, but are not limited to, federally protected species, re-verification of wetland jurisdictional areas, historic and archaeological sites, and 303d (impaired) streams.
- 2.4.3. Excluding the Nationwide Permit No. 6 for geotechnical investigations, the Design-Build Team shall submit one permit modification for the entire R-2721A project. The Design-Build Team shall not submit multiple applications to develop a "staged permitting" process to expedite construction activities in a phased fashion.
- 2.4.4. Direct coordination between the Design-Build Team, the NCTA and the NCDOT's Resident Engineer, Division Environmental Officer, the Hydraulics Unit and the Environmental Analysis Unit (EAU) shall be necessary to ensure proper permit modification application development. Upon completion of the draft permit modification application, the Design-Build Team shall concurrently forward the permit modification application to the above entities for review and acceptance. After all revisions are complete, the NCTA will subsequently forward the permit modification application to the appropriate environmental agencies.
- 2.4.5. Any temporary construction measures, including de-watering, construction access, etc. shall be addressed in the permit modification application. Impacts that result from so-

called temporary measures may not be judged to be temporary impacts by the environmental agencies.

- 2.4.6. The Design-Build Team shall clearly indicate the location and impacts of haul roads and utility relocations in jurisdictional areas. The Design-Build Team shall also identify all proposed borrow and waste sites. Further, the Design-Build Team shall describe the construction methods for all structures. The temporary impact descriptions (haul roads, utility relocations, work bridges, etc.) shall include restoration plans, schedules and disposal plans. The aforementioned information, descriptions and details shall be included in the permit modification application.
- 2.4.7. The NCDOT and NCTA hereby commit to ensuring, to the greatest extent practicable, that the footprint of the impacts in areas under the jurisdiction of the Federal Clean Water Act will not be increased during the Design-Build effort. In accordance with the NCDEQ's NCG 010000, all fill material shall be stabilized and maintained to prevent sediment from entering adjacent waters or wetlands. The Design-Build Team shall be responsible for ensuring that the design and construction of the project will not impair the movement of aquatic life.
- 2.4.8. The NCTA will allow no direct contact between the Design-Build Team and representatives of the environmental agencies. No contact between the Design-Build Team and the environmental agencies shall be allowed either by phone, e-mail or in person, without representatives of the NCDOT's EAU - Environment Coordination and Permitting Group (ECAP) or the NCDOT DEO present. A representative from the NCTA and shall be included on all correspondence.

3. MITIGATION

3.1. Compensatory Mitigation

The NCDOT will be responsible for compensatory mitigation for unavoidable impacts to wetlands, surface waters and riparian buffers due to project construction. In accordance with provisions of the 2016 Memorandum of Agreement between NCDOT and the NC Division of Mitigation Services (NCDMS), NCDOT will rely on NCDMS for mitigation of impacts to wetlands, streams and riparian buffers for R-2721A. NCDOT investigated opportunities for on-site mitigation and found no suitable sites available within the project limits of R-2721A.

3.2. Additional Mitigation Responsibilities of the Design-Build Team

- 3.2.1. Any changes proposed by the Design-Build Team to any design or construction details provided by the NCTA or NCDOT shall be approved by the NCTA prior to being submitted to the environmental regulatory and resource agencies for their approval. Unless the Design-Build Team can demonstrate that the requirements in this RFP caused the additional impacts, the Design-Build Team will be solely responsible for suitable compensatory mitigation for jurisdictional impacts (wetlands, surface waters and riparian buffers) beyond those that are permitted for the R-2721A project due to revised design/construction details. Therefore, it is important to note that additional mitigation will have to be approved by the environmental agencies and such approval shall require,

at a minimum, the preparation and approval of a Mitigation Plan before permits are approved and before construction may commence. To mitigate for these additional jurisdictional impacts, the Design-Build Team shall be responsible for all costs associated with acquiring suitable mitigation. The purchase of mitigation credits through the Division of Mitigation Services is an option for the Design-Build Team.

- 3.2.2. In the absence of suitable on-site mitigation, the Design-Build Team shall be responsible for acquiring additional mitigation from the NC Division of Mitigation Services or an approved compensatory mitigation banking source. In such case, the Department will, upon request of the Design-Build Team, acquire the additional mitigation from the NC Division of Mitigation Services or any excess of credits previously purchased by the Department from private mitigation banks and the Design-Build Team shall compensate the Department for all such mitigation.
- 3.2.3. The Design-Build Team shall analyze all new areas to be impacted that have not been analyzed during the NEPA Process, including, but not limited to, borrow sites, waste sites, haul roads and staging areas that are located outside the project right of way. This analysis shall include performing all environmental assessments. These assessments shall require the Design-Build Team to engage the services of a NCDOT prequalified environmental consultant to conduct a full environmental investigation to include, but not be limited to, Federally Listed Threatened and Endangered Species, wetlands, streams, avoidance and minimization in jurisdictional areas, compensatory mitigation, FEMA compliance, and historical, archaeological, and cultural resources surveys in these areas. The environmental consultant shall obtain concurrence through EAU, to document compliance with Section 7 of the *Endangered Species Act* for those species requiring such concurrence.

4. COMMITMENTS

4.1. General Commitments

- 4.1.1. The NCTA is committed to incorporating all reasonable and practicable design features to avoid and minimize wetland, surface water and riparian buffer impacts, and to provide full compensatory mitigation of all remaining wetland, surface water and riparian buffer impacts. Avoidance measures were taken during the planning and NEPA Process and minimization measures were incorporated as part of the preliminary design provided by NCTA. The Design-Build Team shall incorporate these avoidance and minimization features, plus any minimization identified during the Concurrence Points 4B and 4C Meetings already held (or any additional 4C type meeting required based on the Design-Build Team's design modifications), into the design and/or construction methods at no additional cost or contract time extension.
- 4.1.2. All work by the Design-Build Team must be accomplished in strict compliance with the plans submitted with the permit and permit modification applications and in compliance with all conditions of the permits, permit modifications and certifications issued by the environmental agencies. The Design-Build Team shall provide each of its contractors

and/or agents associated with the construction or maintenance of this project with a copy of the permits and certifications and maintain copies of the permit on site during construction.

- 4.1.3. For ponds to be drained in accordance with the *Roadway Scope of Work*, the Design-Build Team shall develop a Pond Drainage Plan and submit to the NCTA and the environmental regulatory agencies for approval to include, but not be limited to, size, past use, and control structure of the pond; classification, buffer requirements and flow of the receiving waters; procedures and rate of water drawdown; sediment control measures; water quality monitoring procedures; and any plant or wildlife species concerns or considerations and fish relocation plan. This drainage plan shall also address procedures avoiding the inundation of a receiving body of water with deoxygenated or nutrient rich water resulting in impacts to aquatic life or algae bloom and procedures for maintaining downstream channel stability. Verify if the ponds being drained or ponds downstream and receiving the drainage water are on the NC Dam Safety Inventory List. If such ponds are contained in the NC Dam Safety Inventory List, follow all NC Dam Safety procedures.
- 4.1.4. Unless noted otherwise in this RFP, the Design-Build Team shall strictly adhere to these commitments, as well as others, including but not limited to, those included in the planning documents (the approved Complete 540 Draft EIS, the approved Complete 540 Final EIS and the Complete 540 Record of Decision, as well as all permits and interagency meetings and the environmental permits.

4.2. Unknown Historic Architectural or Archaeological Sites

If the Design-Build Team discovers any previously undocumented historic or archaeological resources while conducting the authorized work, they shall immediately suspend activities in that area and notify, in writing, the NCTA and the NCDOT Historic Architecture Group Leader, NCDOT Archaeology Group Leader and the NCDOT Division Environmental Officer, as listed below, who will initiate any required State/Federal coordination after a timely initial assessment. The Design-Build Team shall also immediately notify a representative from the NCTA. Inadvertent or accidental discovery of human remains shall be handled in accordance with North Carolina General Statutes 65 and 70. All questions regarding these discoveries shall be addressed to Mary Pope Furr, NCDOT Historic Architecture Group Leader at (919) 707-6068, Matthew Wilkerson, NCDOT Archaeology Group Leader at (919) 707-6089, or Chris Murray, NCDOT Division Environmental Officer at (919) 220-4600.

TRANSPORTATION MANAGEMENT SCOPE OF WORK

(12-14-18)

1. PRINCIPLE STANDARDS**1.1. Standards**

The Design-Build Team shall design the Transportation Management Plans (TMP) in accordance with the requirements of this RFP and the version of the standards listed below that are effective on the Technical Proposal submittal date.

- NCDOT *Standard Specifications for Roads and Structures*
- NCDOT *Roadway Standard Drawings*
- NCDOT *Supplement to the Manual on Uniform Traffic Control Devices (NCSMUTCD)*
- *FHWA Manual on Uniform Traffic Control Devices (MUTCD)*
- NCDOT *Roadway Design Manual*
- Americans with Disabilities Act of 1990 (ADA)
- *AASHTO A Policy on Geometric Design of Highways and Streets*
- *AASHTO Roadside Design Guide*
- *FHWA Standard Highway Signs and Markings*
- *NCDOT Guidelines for Preparation of Traffic Control and Pavement Marking Plans for Design-Build Projects*
- *NCTA Design-Build Submittal Guidelines*
- *FHWA Rule on Work Zone Safety and Mobility (23 CFR 630 Subpart J and K)*
- Transportation Research Board *Highway Capacity Manual*

1.2. Additional References

The Design-Build Team shall use the references provided on the site below as supplementary guidelines and requirements for the design and implementation of the Transportation Management Plans.

<https://connect.ncdot.gov/projects/WZTC/>

1.3. Prequalification

The Design-Build Team shall select a Private Engineering Firm (PEF) that has experience developing TMP on comparable projects for the North Carolina Department of Transportation (NCDOT).

2. TRANSPORTATION MANAGEMENT PLANS**2.1. General Contents of Transportation Management Plans**

2.1.1. The Design-Build Team shall prepare Transportation Management Plans (TMP) that include Temporary Traffic Control Plans (TTCP) and Traffic Operations Plans (TOP).

The TOP shall include demand management strategies, corridor network management strategies, and traffic incident management and enforcement strategies. In accordance with the *Public Involvement and Information Scope of Work* found elsewhere in this RFP, the Design-Build Team shall assist the Department in the development of a Public Information Plan (PIP).

- 2.1.2. The Design-Build Team shall produce TMP for each phase of work that impacts road users. The TMP shall include details of all planned detours, traffic control devices, striping, and signage applicable to each phase of work. The information on the TMP shall be of sufficient detail to allow verification of design criteria and safety requirements, including but not limited to, typical sections, alignment, striping layout, drop off conditions, and temporary drainage. The Design-Build Team shall develop TMP that include procedures to communicate TMP information to the public about road and travel conditions within the work zone and affected roadway network.

2.2. Transportation Management Phasing Concept

A Transportation Management Phasing Concept (TMPC) shall be prepared by the Design-Build Team to present the Design-Build Team's approach to all areas covered under the TMP, including, but not limited to, hauling of materials to, from, and within the project right of way (ROW). The Design-Build Team shall include the TMPC in the Technical Proposal. The Design-Build Team shall submit the TMPC for Department review and acceptance and shall address NCDOT comments on the TMPC prior to commencing production of the TMP for each phase of work or any construction. Any changes to the TMPC after acceptance by NCDOT shall require a submittal for review and acceptance prior to any future phasing submittals.

3. GENERAL DESIGN AND CONSTRUCTION REQUIREMENTS

3.1. Temporary Barrier Systems

Placement of temporary barrier systems shall be shown on the TMPC. Temporary barrier systems shall be designed in accordance with the following requirements:

- 3.1.1. Determine the need for temporary barrier in accordance with the FHWA *Rule on Temporary Traffic Control Devices* (23 CFR 630 Subpart K). Reference the NCDOT Work Zone Traffic Control website noted below for examples and *Guidelines for the Use of Positive Protection in Work Zones*.

<https://connect.ncdot.gov/projects/WZTC/Pages/Design-Resources.aspx>

- 3.1.2. The Design-Build Team shall adhere to the AASHTO Roadside Design Guide in determining the length of need, flare rate and clear zone. The Design-Build Team shall adhere to the possible deflection of the proposed temporary barrier system in accordance with NCHRP-350 *Recommended Procedures for the Safety Performance Evaluation of Highway Features* deflections from crash testing and MASH (2016 AASHTO Manual for Assessing Safety Hardware). Providing less than the minimum deflection distance

shall require the use of anchored temporary barrier systems in accordance with the NCDOT 2018 *Standard Specifications for Roads and Structures*.

- 3.1.3. When temporary barrier is used continuously on one or both sides of a direction of travel along NC-55 for a distance greater than one mile, the Design-Build Team shall provide a paved motorist breakdown area on the right side of the travel way every mile, unless the outside paved shoulder width (clear distance between edge of travel lane and face of barrier) is ten feet or greater. All breakdown areas shall be a minimum of one thousand feet long and fourteen feet wide, ten feet of which shall be pavement. The breakdown areas shall be identified on the project by use of Changeable Message Signs or Stationary Signs placed in advance of each breakdown area, as approved by the Department. Prior to incorporation, the Design-Build Team shall submit a temporary pavement design for the breakdown areas.
- 3.1.4. The Design-Build Team shall not place temporary barrier systems utilized for traffic control on unpaved surfaces.
- 3.1.5. The Design-Build Team shall not place temporary barrier within 200 feet of any merging taper, including but not limited to, existing and proposed ramp merges, lane drop merges, and/or temporary lane closure merges. All lanes shall first be closed using channelizing devices and pavement markings.
- 3.1.6. The Design-Build Team shall not place temporary barrier along any shifting taper, including but not limited to, existing, temporary, and/or proposed shifting tapers.
- 3.1.7. When barrier is placed on a roadway shoulder, the Design-Build Team shall install shoulder closure signs and devices in advance of the barrier in accordance with the NCDOT Roadway Standard Drawings.

3.2. Temporary Alignments

- 3.2.1. Excluding median crossovers, the design speed for temporary alignments of Interstates, US and NC routes shall not be lower than the current posted speed limit. The minimum allowable design speed for temporary alignments on secondary roads shall be the higher of 10 mph below the posted speed limit or 35 mph.
- 3.2.2. The NCDOT Roadway Standard Drawing No. 1101.11 shall be used to calculate the length of temporary merges for lane closures and temporary traffic shifts. For temporary traffic patterns that will remain in place for a period longer than three days, including but not limited to traffic shifts, merges and temporary alignments, breaks in the superelevation and/or breaks in a normal crown section will not be allowed within the shifting taper. Excluding the aforementioned temporary traffic patterns, breaks in the superelevation and/or breaks in a normal crown section shall only occur on a lane line or lane midpoint, and shall not exceed 0.04.
- 3.2.3. Temporary traffic shifts that are not covered by a standard or require vertical grades shall be considered a temporary alignment. All temporary alignments shall adhere to the

NCDOT *Roadway Design Manual*, including all revisions, 2011 AASHTO *A Policy on Geometric Design of Highways and Streets* and the most current Transportation Research Board *Highway Capacity Manual*.

3.3. Maintenance of Access

- 3.3.1. Maintain access to all residences, schools, bus stops, mass transit facilities (park and ride lots), emergency services and businesses at all times. Prior to incorporation, obtain written approval from the Engineer on the method to maintain access. Access to all existing transit stop locations shall be maintained during construction or alternative locations that are accepted by NCDOT shall be provided and specified within the TMP. The Design-Build Team shall coordinate with the Triangle Transit System and other Transit Agencies for all traffic control phasing that will affect existing transit stops or transit routes.
- 3.3.2. At all times, maintain existing sidewalk/greenway access, provide temporary sidewalk/greenway (constructed of concrete, asphalt or other suitable material, as approved by the Engineer), and/or provide a sidewalk/greenway detour at all locations where the open pedestrian travelway has been closed and/or removed by the Design-Build Team's design or construction operations. Prior to incorporation, all sidewalk/greenway detours shall receive Department written approval.
- 3.3.3. Through traffic traveling in the same direction shall not be split. (i.e. separation by any type of barrier, bridge piers, existing or proposed median, etc.).
- 3.3.4. Prior to incorporation, obtain written approval from the Engineer for all road and/or access point closures.
- 3.3.5. On all roadways within the project limits, the Design-Build Team shall provide safe access for wide-loads and oversized permitted vehicles through the work zone. Safe access shall entail, but not be limited to, a sufficient pavement structure (Reference the *Pavement Management Scope of Work* found elsewhere in this RFP), maintaining the existing vertical clearance of overhead structures, providing the required vertical clearance of proposed overhead structures, and providing the minimum horizontal clear widths as follows:

Roadway	Minimum Clear Width
Interstates, US routes, NC Routes, and all ramps and loops	20 feet
All other roadways	18 feet

3.4. Off-Site Detours

- 3.4.1. Prior to incorporation, all offsite detour routes shall receive Department written approval and allow for all roads and lanes to remain open to traffic unless otherwise governed by an Intermediate Contract Time specific herein. Submit detour routes and all associated sign designs for review and acceptance prior to incorporation.

- 3.4.2. The Design-Build Team shall investigate all detour routes including, but not limited to, analyzing traffic capacity, investigating impacts to emergency services and schools, analyzing design characteristics to ensure the design supports the traffic volumes (existing traffic volumes plus detoured traffic volumes), and investigating pavement structural adequacy including any bridge postings on the detour route. The Design-Build Team shall submit recommendations resulting from the aforementioned investigations/analyses for the Department's review and acceptance.
- 3.4.3. As determined by the Engineer, the Design-Build Team shall provide all improvements required to accommodate detoured traffic prior to utilizing detour routes.
- 3.4.4. Offsite detours that have non-signalized at-grade railroad crossings shall not be allowed.
- 3.4.5. All proposed road closures, detour routes, durations and justifications shall be incorporated into the Technical Proposal. (All proposed road closures, detour routes, durations and justifications incorporated into the Technical Proposal shall require Department approval.)
- 3.4.6. Unless approved otherwise by the controlling government entity, in writing, use only state maintained roads for offsite detour routes.

3.5. Impacts to Other Network Roadways

- 3.5.1. The Design-Build Team shall coordinate with the Division Maintenance Engineer, Resident Engineer, Division Traffic Engineer, the Rail Division and Statewide Transportation Operations Center (STOC) to manage traffic operations within the work zone and other roadways within the network that may be affected by the work zone activities. Coordination shall include, but not be limited to, providing notification of planned lane or road closures, traffic detours, public information, traffic management, access management, incidents, etc.
- 3.5.2. On all roads, the Design-Build Team shall make all modifications to existing pavement markings, markers and/or signing located outside the project limits that are necessitated by the TMP. Additionally, the Design-Build Team shall readjust the markings, markers, and/or signing located outside the project limits to the existing/proposed pattern when the temporary changes are no longer needed.
- 3.5.3. All on-site detours shall meet the minimum number of existing lanes per direction and shall adhere to all temporary alignment requirements noted elsewhere in the RFP. A pavement transition, suitable for the posted speed limit shall be provided at all on-site detour interfaces.
- 3.5.4. The Design-Build Team shall not place traffic on lanes containing rumble strips.
- 3.5.5. The Design-Build Team shall take steps to minimize disruptions to existing roadway facilities during construction and shall demonstrate how the traffic control phasing

minimizes inconvenience to motorists on all roads.

4. LANE AND ROAD CLOSURE NOTIFICATION

4.1. Lane Closure Notice (LCN)

- 4.1.1. The Design-Build Team shall issue a Lane Closure Notice (LCN) to NCDOT and affected government entities a minimum of twenty-one (21) calendar days prior to the publication of any notices or placement of any traffic control devices associated with lane closures, detour routing or other change in traffic control requiring lane closures. The Design-Build Team will be allowed to issue a single LCN for multiple/consecutive lane closures that occur in the same location.
- 4.1.2. For a LCN utilizing a non-NCDOT controlled facility, the Design-Build Team shall secure concurrence in writing from the controlling government entity. A LCN shall contain the estimated date, time, duration and location of the proposed work. The Design-Build Team shall keep NCDOT informed of any and all changes or cancellations of proposed lane closures prior to the date of their implementation.
- 4.1.3. If an emergency condition should occur, a LCN shall be provided to NCDOT within two (2) days after the event. For non-NCDOT controlled facilities, the Design-Build Team shall immediately notify the controlling government entity.

4.2. Road Closure Notice (RCN)

- 4.2.1. Proposed road closures on any road shall be approved by the Engineer prior to incorporation in the TMP.
- 4.2.2. The Design-Build Team shall issue a Road Closure Notice (RCN) to NCDOT and affected government entities a minimum of twenty one (21) calendar days prior to the publication of any notices or placement of any traffic control devices associated with road closures, detour routing or other change in traffic control requiring road closures.
- 4.2.3. For a RCN utilizing a non-NCDOT controlled facility, the Design-Build Team shall secure concurrence in writing from the controlling government entity. A RCN shall contain the estimated date, time, duration, and location of the proposed work. The Design-Build Team shall keep NCDOT and any other affected government entity informed of any and all changes or cancellations of proposed road closures prior to the date of their implementation.
- 4.2.4. If an emergency condition should occur, a RCN shall be provided to NCDOT within two (2) days after the event. For non-NCDOT controlled facilities, the Design-Build Team shall immediately notify the controlling government entity.

5. PROJECT OPERATIONS REQUIREMENTS – TIME RESTRICTIONS

Unless permitted otherwise elsewhere in this RFP, maintain the existing number of travel lanes on all roads, including but not limited to acceleration, deceleration, auxiliary, and turn lanes. For existing travel lanes that are 11-foot wide or wider, maintain a minimum of 11-foot travel lanes at all times. For existing travel lanes that are narrower than 11 feet, maintain the existing travel lane widths at all times. Unless permitted otherwise elsewhere in this RFP, maintain existing shoulder widths (paved and unpaved). The following are Time Restrictions and notes that shall be included with the TMP General Notes, unless noted otherwise elsewhere in this RFP.

5.1. Intermediate Contract Times #2 and #3 for Lane Narrowing, Lane Closure, Holiday and Special Event Restrictions

- 5.1.1. Except as may otherwise be allowed elsewhere in this RFP, the Design-Build Team shall maintain the existing traffic pattern and shall not close or narrow a lane of traffic during the times listed in ICT #2, ICT #3, and ICT #4. More than one lane on each facility may not be closed at the same time without prior approval from the NCTA.

Intermediate Contract Time #	Road Name	Day	Time Restrictions
#2	NC-55 (East Williams Street) SR 1301 (Sunset Lake Road) SR 1152 (Holly Springs Road) SR 1389 (Pierce Olive Road)	Monday through Sunday	6:00 a.m. to 7:00 p.m.
#3	NC-55 Bypass (GB Alford Highway) NC 540	Monday through Sunday	5:00 a.m. to 9:00 p.m.
#4	All Other Roads	Monday through Friday	6:00 a.m. to 9:00 a.m. and 3:00 p.m. to 7:00 p.m.

- 5.1.2. The Design-Build Team shall not install, reset and/or remove any traffic control device during the times listed in ICT #2, ICT #3, and ICT #4.

- 5.1.3. In addition, the Design-Build Team shall not close or narrow a lane of traffic on the aforementioned facilities, detain the traffic flow or alter the traffic flow on or during holidays, holiday weekends, special events, or any other time when traffic is unusually heavy. At a minimum, these requirements/restrictions shall apply to the following schedules:

- For any unexpected occurrence that creates unusually high traffic volumes, as

directed by the Engineer.

- For New Year's between the hours of 5:00 a.m. December 31st and 9:00 p.m. January 2nd. If New Year's Day is on a Friday, Saturday, Sunday or Monday, then until 9:00 p.m. the following Tuesday.
- For Easter, between the hours of 5:00 a.m. Thursday and 9:00 p.m. Monday.
- For Memorial Day, between the hours of 5:00 a.m. Friday and 9:00 p.m. Tuesday.
- For Independence Day, between the hours of 5:00 a.m. July 3rd and 9:00 p.m. July 5th. If Independence Day is on a Friday, Saturday, Sunday or Monday, then between the hours of 5:00 a.m. the Thursday before Independence Day and 9:00 p.m. the Tuesday after Independence Day.
- For Labor Day, between the hours of 5:00 a.m. Friday and 9:00 p.m. Tuesday.
- For Thanksgiving Day, between the hours of 5:00 a.m. Tuesday and 9:00 p.m. Monday.
- For Christmas, between the hours of 5:00 a.m. the Friday before the week of Christmas Day and 9:00 p.m. the following Tuesday after the week of Christmas Day.
- For the North Carolina State Fair, on both directions of NC-55 Bypass (GB Alford Highway), every day the State Fair is open to the public from 9:00 a.m. to 12:00 a.m. (midnight).

5.1.4. Liquidated Damages for Intermediate Contract Time #2 for the above lane narrowing, lane closure, holiday, and special event time restrictions for NC 55 (East Williams Street), SR 1301 (Sunset Lake Road), SR 1152 (Holly Springs Road), and SR 1389 (Pierce Olive Road) are \$1,000.00 per hour period or any portion thereof.

5.1.5. Liquidated Damages for Intermediate Contract Time #3 for the above lane narrowing, lane closure, holiday and special event time restrictions for any lane on NC-55 Bypass (GB Alford Highway) and any ramps or loops are \$5,000.00 per 30-minute period or any portion thereof.

5.1.6. Liquidated Damages for Intermediate Contract Time #4 for the above lane narrowing, lane closure, holiday and special event time restrictions for all other roads not included in ICT #2 and ICT#3 are \$1,000.00 per hour or any portion thereof.

5.2. Intermediate Contract Times #5 and #6 for Road Closure Restrictions for Construction Operations

5.2.1. Unless allowed otherwise elsewhere in this RFP, at a minimum, the Design-Build Team shall maintain the existing traffic pattern and follow the road closure restrictions for the roadways listed in ICT #5 and ICT #6. When a temporary road closure is used, the Design-Build Team shall reopen the travel lanes by the end of the road closure duration

to allow the traffic queue to deplete before re-closing the roadway.

- 5.2.2. Unless allowed otherwise elsewhere in this RFP, the Design-Build Team shall 1) not close any direction of travel on the following roads or any ramps/loops during the times noted in ICT #5 and ICT #6 and 2) only close the following roads or any ramps /loops for the operations listed in Section 5.2.4.

Intermediate Contract Time #	Road Name	Day	Time Restrictions
#5	NC-55 (East Williams Street) SR 1301 (Sunset Lake Road) SR 1152 (Holly Springs Road) SR 1389 (Pierce Olive Road)	Monday through Sunday	6:00 a.m. to 10:00 p.m.
#6	NC-55 Bypass (GB Alford Highway) and all NC-540 (Triangle Expressway) ramps and loops once open to traffic	Monday through Sunday	5:00 a.m. to 12:00 a.m. (Midnight)

- 5.2.3. A crossover providing one lane in each direction on NC-55 Bypass (GB Alford Highway), as applicable, will be allowed for the purpose of bridge demolition, and girder, overhang, and falsework installation and/or removal during the times set forth in ICT #6. If the Design-Build Team elects to use a crossover for the aforementioned activities, the crossover shall be designed and constructed to meet a design speed of no more than 20 mph below the original speed limit. Unless approved otherwise by the Department, in writing, the maximum allowable distance between the crossovers shall be 2,750 feet. The Design-Build Team shall monitor the traffic queue during operation of the crossover. Should the traffic queue extend to the advance warning signs, traffic shall be returned to the existing number of lanes in each direction until the traffic queue is depleted.
- 5.2.4. For the operations noted below, the maximum road closure duration shall not exceed thirty (30) minutes without an approved offsite detour. With an approved offsite detour, the roadways listed may be closed during the time listed in ICT #5 and ICT #6 for the operations listed below.
- Bridge demolition
 - Girder, overhang, and falsework installation and/or removal
 - Installation of overhead sign assemblies and/or work on existing overhead sign assemblies over travel lanes, or Signal poles and cables across roadways
 - Tie-in work to implement or remove an on-site detour
- 5.2.5. Prior to incorporation in the TMP, the Design-Build Team shall obtain written approval

from the Engineer for all road closures.

- 5.2.6. **Liquidated Damages for Intermediate Contract Time #5 for the above road closure time restrictions for NC 55 (East Williams Street), SR 1301 (Sunset Lake Road), SR 1152 (Holly Springs Road), and SR 1389 (Pierce Olive Road) are \$250.00 per 15-minute period or any portion thereof.**
- 5.2.7. **Liquidated Damages for Intermediate Contract Time #6 for the above road closure time restrictions for NC 55 Bypass (GB Alford Highway) and all NC 540 (Triangle Expressway) ramps or loops once open to traffic is \$5,000.00 per 15-minute period or any portion thereof.**

5.3. Other Intermediate Contract Times

In the event any self-imposed liquidated damages are included in the Technical Proposal, an Intermediate Contract Time(s) shall be established and shall become part of the contract.

6. PROJECT OPERATIONS REQUIREMENTS – HAULING RESTRICTIONS

6.1. General

- 6.1.1. The Design-Build Team shall adhere to the hauling restrictions noted in the NCDOT *Standard Specifications for Roads and Structures*.
- 6.1.2. The Design-Build Team shall address how hauling will be conducted in the Technical Proposal, including but not limited to, hauling of any materials to and from the site and hauling material within the NCDOT right of way.

6.2. Hauling Limitations

The Design-Build Team shall conduct all hauling operations as follows:

- 6.2.1. The Design-Build Team shall not conduct any hauling operations against the flow of traffic of an open travelway unless an approved temporary traffic barrier or guardrail separates the traffic from the hauling operation.
- 6.2.2. All hauling entrances, exits and crossings shall be shown on the TMP and be in accordance with the NCDOT Roadway Standard Drawings.
- 6.2.3. Haul vehicles shall not enter and/or exit an open travel lane at speeds more than 10 mph below the posted speed limit.
- 6.2.4. Hauling operations that perpendicularly cross a roadway shall require approved Traffic Control Plans and shall be subject to the holiday and special event time restrictions listed in Subsection 5.1.3. Hauling operations shall not perpendicularly cross NC-55 Bypass (GB Alford Highway).
- 6.2.5. Excluding hauling operations that are conducted entirely behind a temporary traffic

barrier or guardrail, hauling shall not be allowed ingress and egress from any open travel lane during the lane narrowing, lane closure and holiday time restrictions listed in ICT #2, ICT #3, and ICT #4.

7. ADDITIONAL PROJECT OPERATIONS REQUIREMENTS

7.1. Lane and Shoulder Closure Requirements

- 7.1.1. On two-lane, two-way facilities, the Design-Build Team shall not install more than one (1) mile of lane closure in any one direction on any roadway within the project limits or in conjunction with this project, measured from the beginning of the merge taper to the end of the lane closure.
- 7.1.2. The Design-Build Team shall not install more than two simultaneous lane closures in any one direction on any roadway within the project limits or in conjunction with this project and shall provide a minimum of four (4) miles between lane closures, measured from the end of one closure to the first sign of the next lane closure.
- 7.1.3. The Design-Build Team shall remove lane closure devices from the lane when work is not being performed behind the lane closure or when a lane closure is no longer needed.
- 7.1.4. When barrier is placed on the roadway shoulder, the Design-Build Team shall install shoulder closure signs and devices in advance of the barrier using the NCDOT Roadway Standard Drawings.
- 7.1.5. When personnel and/or equipment are working within 15 feet of an open travel lane, the Design-Build Team shall close the nearest open shoulder using the NCDOT *Roadway Standard Drawings*, unless the work area is protected by an approved temporary traffic barrier or guardrail.
- 7.1.6. When personnel and/or equipment are working on the shoulder adjacent to an undivided facility and within five feet of an open travel lane, the Design-Build Team shall, at a minimum, close the nearest open travel lane using the NCDOT *Roadway Standard Drawings*, unless the work area is protected by an approved temporary traffic barrier or guardrail.
- 7.1.7. When personnel and/or equipment are working on the shoulder adjacent to a divided facility and within ten feet of an open travel lane, the Design-Build Team shall, at a minimum, close the nearest open travel lane using the NCDOT *Roadway Standard Drawings*, unless the work area is protected by an approved temporary traffic barrier or guardrail.
- 7.1.8. When personnel and/or equipment are working within a lane of travel of an undivided or divided facility, the Design-Build Team shall, at minimum, close the lane using the NCDOT *Roadway Standard Drawings*. The Design-Build Team shall conduct the work so that all personnel and/or equipment remain within the closed travel lane.

- 7.1.9. The Design-Build Team shall not perform work involving heavy equipment within 15 feet of the edge of travelway when work is being performed behind a lane closure on the opposite side of the travelway.

7.2. Pavement Edge Drop off Requirements

- 7.2.1. Using suitable compacted material, the Design-Build Team shall backfill at a 6:1 slope up to the edge and elevation of the existing pavement in areas adjacent to an open travel lane that has an edge of pavement drop-off as follows:
- Elevation differences that exceed two inches on roadways with posted speed limits of 45 mph or greater and a paved shoulder four-foot wide or less.
 - Elevation differences greater than three inches on roadways with posted speed limits less than 45 mph and with a paved shoulder four-foot wide or less.
 - Refer to the current *AASHTO Roadside Design Guide* for proper treatment of all other conditions.
- 7.2.2. Do not exceed a difference of two inches in elevation between open lanes of traffic for nominal lifts of 1.5 inches. Install advance warning “UNEVEN LANES” signs (W8-11) 1,000 feet in advance and a minimum of every half mile throughout the uneven area.

7.3. Traffic Pattern Alterations

The Design-Build Team shall notify the Engineer in writing at least twenty-one (21) calendar days prior to any traffic pattern alteration. (Reference the *Public Involvement and Information Scope of Work* found elsewhere in this RFP for additional public information requirements)

7.4. Signing

- 7.4.1. The Design-Build Team shall install advance work zone warning signs when work is within 40 feet from the edge of travel lane and no more than three days prior to the beginning of construction.
- 7.4.2. When no work is being conducted for a period longer than one week, the Design-Build Team shall remove or cover all advance work zone warning signs, as directed by the Engineer. Stationary work zone warning signs shall be covered with an opaque material that prevents reading of the sign at night by a driver traveling in either direction.
- 7.4.3. When portable work zone signs are not in use for periods longer than 30 minutes, the Design-Build Team shall lay the portable work zone sign flat on the ground and collapse the sign stand and lay it flat on the ground.
- 7.4.4. The Design-Build Team shall install and maintain all detour signing and devices required for road closures. The Design-Build Team shall cover or remove all detour signs and devices required for road closures within and off the project limits when a detour is not in operation.

- 7.4.5. The Design-Build Team shall ensure proper signing (including but not limited to guide signs) is in place at all times during construction, as required by the *MUTCD*. All temporary signing shall be shown on the Traffic Control Plans or Temporary Signing Plans to be reviewed and approved by the Work Zone Traffic Control Section and/or the Signing and Delineation Unit prior to incorporation.

7.5. Traffic Barrier

- 7.5.1. The Design-Build Team shall use only an NCDOT approved temporary traffic barrier system.
- 7.5.2. Install temporary traffic barrier system a maximum of two (2) weeks prior to beginning work in any location. Once the temporary traffic barrier system is installed at any location, proceed in a continuous manner to complete the proposed work in that location.
- 7.5.3. Place all temporary barrier used for traffic control directly on an asphalt or concrete surface.
- 7.5.4. Temporary barrier used for traffic control shall not act as a retaining wall.
- 7.5.5. Once the temporary traffic barrier system is installed and no work has been or will be performed behind the temporary traffic barrier system for a period longer than two (2) months, remove/reset the temporary traffic barrier system unless the barrier is protecting traffic from a hazard.
- 7.5.6. Excluding water filled barrier, protect the approach end of temporary traffic barrier system at all times during the installation and removal of the barrier by either a truck mounted impact attenuator (maximum 72 hours) or a temporary crash cushion.
- 7.5.7. Excluding water filled barrier, protect the approach end of temporary traffic barrier system from oncoming traffic at all times by a temporary crash cushion unless the approach end of temporary traffic barrier system is offset from oncoming traffic as follows:

Posted speed limit (mph)	Minimum offset (feet)
40 or less	15
45 – 50	20
55	25
60 mph or higher	30

- 7.5.8. Install temporary traffic barrier system with the traffic flow, beginning with the upstream side of traffic. Remove the temporary traffic barrier system against the traffic flow, beginning with the downstream side of traffic.
- 7.5.9. Install drums to close or keep closed the closed sections of the roadway until the

temporary traffic barrier system can be placed or after the temporary traffic barrier system has been removed. The distance, in feet, between drums shall be no greater than twice the posted speed limit (mph).

- 7.5.10. The Design-Build Team shall be responsible for providing proper connection between the existing bridge rail and the temporary traffic barrier system and include this information in the appropriate plans.

7.6. Traffic Control Devices

- 7.6.1. The Design-Build Team shall use traffic control devices that conform to all NCDOT requirements and are listed on the NCDOT Approved Products List. The Approved Products List may be referenced on the website noted below:

<https://apps.ncdot.gov/vendor/approvedproducts/>

The use of any devices that are not shown on the NCDOT Approved Products List shall require written approval from the Design-Build Unit prior to incorporation.

- 7.6.2. Channelizing device spacing shall not exceed a distance in feet equal to twice the posted speed limit. Channelization devices shall be spaced ten feet on-center in radii. Channelization devices shall be two feet off the edge of an open travelway, when lane closures are not in effect. Skinny drums shall only be allowed as defined in Section 1180 of the NCDOT *Standard Specifications for Roads and Structures*.
- 7.6.3. Place Type III barricades, with "ROAD CLOSED" signs (R11-2) attached, of sufficient length to close entire roadway. Stagger or overlap barricades to allow for ingress or egress.
- 7.6.4. Place sets of three drums perpendicular to the edge of the travelway on 500-foot centers when unopened lanes are closed to traffic. These drums shall be in addition to channelizing devices.
- 7.6.5. Portable changeable message signs should be placed off the shoulder of the roadway and behind a traffic barrier, if practical. Where a traffic barrier is not available to shield the portable changeable message sign, it should be placed off the shoulder and outside of the clear zone. If a portable changeable message sign must be placed on the roadway shoulder or within the clear zone, it shall be delineated with retroreflective temporary traffic control (TTC) devices. When portable changeable message signs are not being used to display TTC messages, they should be relocated such that they are outside of the clear zone or shielded behind a traffic barrier, and turned away from traffic. If relocation or shielding is not practical, the portable changeable message signs shall be delineated with retroreflective TTC devices.

7.7. Temporary Pavement Markings, Markers and Delineation on NC-55 Bypass

- 7.7.1. The Design-Build Team shall show temporary pavement markings on the TMP that meet the requirements of Section 7.8 of this Scope of Work and the *Guidelines for*

Preparation of Traffic Control and Pavement Marking Plans for Design-Build Projects.

- 7.7.2. The Design-Build Team shall install pavement markings and markers in accordance with the NCDOT 2018 *Standard Specifications for Roads and Structures*, and in accordance with the manufacturer's procedures and specifications.
- 7.7.3. In accordance with the requirements below, the Design-Build Team shall install Work Zone "Performance" pavement markings on the interim surface for temporary traffic patterns. The Design-Build Team shall install temporary raised pavement markers on the interim surface for temporary traffic patterns.
- 7.7.4. Temporary pavement markings on concrete surfaces shall only be removed by hydroblasting.
- 7.7.5. Prior to shifting traffic to a new pattern, the Design-Build Team shall mask/conceal, remove, or mill and fill, as appropriate, all conflicting markings and remove all conflicting markers and snowplowable marker castings. (Reference the Pavement Management Scope of Work and *Work Zone Pattern Masking Project Special Provision* found elsewhere in this RFP for this option). Grinding as a method of pavement marking removal will not be permitted.
- 7.7.6. The Design-Build Team shall tie proposed pavement marking lines to existing pavement marking lines.
- 7.7.7. By the end of each day's operation, the Design-Build Team shall mask/conceal, remove, or mill and fill, as appropriate, all conflicting markings, replace all damaged markings, and remove/replace all conflicting/damaged markers. Grinding as a method of pavement marking removal will not be permitted.

7.8. Work Zone "Performance" Pavement Markings

The Design-Build Team shall furnish and install Work Zone "Performance" pavement markings that delineate the travel way for work zone traffic patterns on NC-55 Bypass. The purpose of Work Zone "Performance" pavement marking is to provide a more durable work zone pavement marking that shall last the full duration of a traffic pattern without requiring replacement or reapplication for a period of up to 12 months. The Work Zone "Performance" pavement markings shall also provide a higher performance level, for both initial and residual retroreflectivity, than standard traffic paints to improve nighttime work zone visibility.

Use materials in accordance with the following:

- 7.8.1. Use materials in accordance with the Manufacturer's recommendations that shall retain both durability and a minimum retroreflectivity, as described elsewhere in this RFP, for a period of at least 12 months.
- 7.8.2. On concrete pavement, the Design-Build Team shall provide black contrast "Performance" pavement markings that contrast the white skip line along through lanes

and ramp lanes. The black contrast “Performance” pavement marking shall immediately follow the white skip line at the same width and half the length, or border the long edges of the white skip line at a width of 1.5 inches. Black contrast “Performance” pavement markings shall be matte and non-retroreflective.

7.8.3. The Work Zone “Performance” pavement markings shall be manufactured to bond successfully to both concrete and asphalt pavements. The pavement marking materials shall be applied in a single application. The following are approved materials to be used for Work Zone “Performance” pavement markings:

- Polyurea
- Thermoplastic (Extruded and Sprayed)
- Epoxy
- Polymer (Single System)
- Cold Applied Plastic Type 4

7.8.4. When using Cold Applied Plastic Type 4 pavement markings, place temporary raised markers half on and half off edge lines and centerlines to help secure the tape to the roadway. Markers shall be spaced the appropriate distance apart as described by the 2018 Roadway Standard Drawing 1250.01, Sheet 1 of 3.

7.8.5. The Design-Build Team shall only use Work Zone “Performance” pavement marking materials, as listed above, which are on the NCDOT Approved Products List at the time of installation. In accordance with Article 106-3, and Section 1087-4 of the NCDOT 2018 *Standard Specifications for Roads and Structures*, the Design-Build Team shall provide a Type 3 Material Certification for all materials, and a Type 3 and Type 4 certification for all reflective media.

Application and testing shall be in accordance with the following:

7.8.6. The Design-Build Team shall not use hand applied methods or any other non-truck mounted application equipment / device to install Work Zone “Performance” pavement markings for applications longer than 1,000 feet.

7.8.7. All Work Zone “Performance” pavement markings shall be installed in a single application.

7.8.8. All Work Zone “Performance” pavement markings shall be tested by the Department through an independent Mobile Retroreflective Contractor. The Work Zone “Performance” pavement markings will be scanned to ensure the retroreflectivity requirements in Sections 7.8.12 and 7.8.17 below are met.

7.8.9. Application equipment shall be in accordance with Section 1205 of the NCDOT 2018 *Standard Specifications for Roads and Structures*. The Work Zone “Performance” pavement marking material shall be applied at the following minimum thicknesses:

- Polyurea = 20 mils wet
- Epoxy = 20 mils wet
- Thermoplastic (Extruded or Sprayed) = 50 mils wet
- Polymer = 20 mils wet
- Cold Applied Plastic (IV) = Manufacturer's recommendation

7.8.10. The Work Zone "Performance" pavement marking line widths shall be as follows:

- Edge lines, Solid Lane Lines, Skip and Mini-Skip Lines = 6"
- Gorelines = 12"

7.8.11. "No track" dry times for the liquid systems shall be ten minutes or shorter. Traffic shall not be placed on any material until it is sufficiently dry / cured to eliminate wheel tracking.

7.8.12. The minimum level of retroreflectivity for all Work Zone "Performance" pavement marking system selected shall be as follows:

Reflectometer Requirements for Work Zone "Performance" Pavement Markings

Color	Initial	6 Months	12 Months
White	375 mcd/lux/m ²	275 mcd/lux/m ²	150 mcd/lux/m ²
Yellow	250 mcd/lux/m ²	150 mcd/lux/m ²	100 mcd/lux/m ²

7.8.13. For the durations noted in the chart above, the Work Zone "Performance" pavement markings shall adhere to the corresponding retroreflectivity levels.

7.8.14. The Design-Build Team shall notify the Engineer, in writing, a minimum of 7 - 10 days prior to the installation of Work Zone "Performance" pavement markings. The Department will measure initial retroreflectivity levels with a mobile retroreflector within 30 days after placement to ensure compliance with the reflectivity levels in the chart above.

7.8.15. Work Zone "Performance" pavement markings shall maintain the retroreflectivity levels for the durations noted above. If the markings appear to be non-performing, in the Engineer's sole discretion, the Engineer may request additional retroreflectivity readings. If and when this becomes necessary, the same notification procedure as described above shall be used to have Work Zone "Performance" pavement markings measured by a Mobile Retroreflective Contractor.

7.8.16. If measured and found to be noncompliant, the Design-Build Team shall replace the Work Zone "Performance" pavement markings at no cost to the Department.

7.8.17. All Work Zone "Performance" pavement markings shall be durable enough to withstand a single snow event without showing excessive fatigue in either bonding or

retroreflectivity. The Design-Build Team shall replace the Work Zone “Performance” pavement markings if a single snowplow event results in more than 25% of the pavement marking edgelines or skips being physically removed and / or the Work Zone “Performance” pavement markings do not meet the following minimum retroreflectivity values:

Reflectometer Requirements for Work Zone “Performance” Pavement Markings after a Single Snowplowed Event

Color	MINIMUM
White	150 mcd/lux/m ²
Yellow	100 mcd/lux/m ²

- 7.8.18. Unless the temporary traffic pattern is to be modified within 30 days, the Design-Build Team shall replace all non-compliant Work Zone “Performance” pavement markings within 30 days of determining they are non-compliant.
- 7.8.19. If the work zone experiences more than one snow event requiring snowplowing, the retroreflectivity values in the chart above will no longer apply. The Engineer will determine if the pavement markings are performing adequately and / or if replacement is necessary due to excessive damage caused solely by snowplow activities. If the Work Zone “Performance” pavement markings are found to be deficient, solely in the Engineer’s discretion, they shall be replaced. In such case, the Work Zone “Performance” pavement markings will be paid for as extra work in accordance with Subarticle 104-8-(A) of the NCDOT 2018 *Standard Specifications for Roads and Structures* at the unit price of \$0.40 per linear foot. Unless the temporary traffic pattern is to be modified within 30 days, the Design-Build Team shall replace all Work Zone “Performance” pavement markings damaged due to multiple snowplow events within 30 days.
- 7.8.20. If the Work Zone “Performance” pavement markings need to remain in place longer than 12 months, the markings shall be scanned by a Mobile Retroreflective Contractor. If the Work Zone “Performance” pavement markings meet or exceed the 12-month retroreflectivity requirements noted above, the markings can remain in place. If the Work Zone “Performance” pavement markings do not meet or exceed the 12-month retroreflectivity requirements noted above, the Design-Build Team shall replace the Work Zone “Performance” pavement markings within 15 days of the 12-month duration date at no cost to the Department. If and when this becomes necessary, the same notification procedure as described above shall be used to have Work Zone “Performance” pavement markings measured by a Mobile Retroreflective Contractor.
- 7.8.21. Prior to installation, all pavement surfaces to receive Work Zone “Performance” pavement markings shall be swept clean and prepared in accordance with the Manufacturer’s recommendation.
- 7.8.22. Work Zone “Performance” pavement markings shall only be applied when the ambient air temperature and the pavement temperature are 50°F or higher for thermoplastic and

are 40°F or higher for all other materials. The Design-Build Team shall not install Work Zone “Performance” pavement markings unless the pavement surface is completely dry. The Design-Build Team shall not install Work Zone “Performance” pavement markings within four hours of a heavy rain event, (rainfall intensities equal to or greater than 1 inch /per hour).

- 7.8.23. In the event a traffic shift must occur when the air and / or pavement temperatures are below the aforementioned minimums and / or a rain event occurs four hours prior to or during a planned traffic shift, the Design-Build Team may install temporary pavement marking paint, at the Engineer’s sole discretion. Temporary pavement marking paint shall be applied in one application and shall produce a four-inch wide line at 15 mils (wet). Beads that provide the following minimum retroreflectivity shall be applied to the temporary pavement marking paint:

White:	225 mcd / lux / m ²
Yellow:	200 mcd / lux / m ²

- 7.8.24. The temporary pavement marking paint with beads shall maintain the minimum retroreflectivity noted above until placement of the Work Zone “Performance” pavement markings
- 7.8.25. The Design-Build Team shall replace / reapply temporary pavement marking paint with beads that does not adhere to the retroreflectivity requirements noted above at no cost to the Department. The Design-Build Team shall apply the Work Zone “Performance” pavement markings within 90 days of installing the temporary pavement marking paint with beads.
- 7.8.26. Excluding damage due solely to snowplow events, the Design-Build Team shall replace all Work Zone “Performance” pavement material that debonds and /or does not adhere to the retroreflectivity levels for the corresponding durations noted above at no cost to the Department.

7.9. Temporary Pavement Markings, Markers and Delineation on All Other Roads

- 7.9.1. The Design-Build Team shall show temporary pavement markings on the Transportation Management Plans that meet the requirements of the RFP and the *Guidelines for Preparation of Traffic Control and Pavement Marking Plans for Design-Build Projects*.
- 7.9.2. The Design-Build Team shall only use pavement marking and marker products that conform to all NCDOT requirements and are listed on the NCDOT Approved Products List. The use of any devices that are not shown on the NCDOT Approved Products List shall require written approval from the Design-Build Unit prior to incorporation.
- 7.9.3. The Design-Build Team shall install pavement markings and markers in accordance with the 2018 NCDOT *Standard Specifications for Roads and Structures*, and in accordance with the manufacturer’s procedures and specifications.

- 7.9.4. The Design-Build Team shall install temporary pavement markings that are the same width as existing pavement markings. For roadways that do not have existing pavement markings, the Design-Build Team shall install temporary pavement markings that are the same width required for the final pavement markings in the *Pavement Markings Scope of Work* found elsewhere in this RFP.
- 7.9.5. The Design-Build Team shall install temporary pavement markings and temporary pavement markers on the interim surface or temporary pattern as follows:

Road	Marking	Marker
All roads and structures, except NC-55 Bypass	Any Marking on the Approved Product List	Raised Temporary

- 7.9.6. The Design-Build Team may use any type of pavement markings on the NCDOT Approved Products List for temporary patterns. However, the Design-Build Team shall maintain a minimum retroreflectivity for pavement markings (existing and temporary markings) at all times during construction, as follows:
- White: 125 mcd/lux/m²
Yellow: 100 mcd/lux/m²
- 7.9.7. When using Cold Applied Plastic Type 4 pavement markings, place temporary raised markers half on and half off edge lines and centerlines to help secure the tape to the roadway. Markers shall be spaced the appropriate distance apart as described by the 2018 NCDOT *Roadway Standard Drawing* No. 1250.01, Sheet 1 of 3.
- 7.9.8. The Design-Build Team shall tie proposed pavement marking lines to existing pavement marking lines.
- 7.9.9. By the end of each day's operation, the Design-Build Team shall remove all conflicting markings, replace all damaged markings, and remove/replace all conflicting/damaged pavement markers.
- 7.9.10. The Design-Build Team shall trace existing and/or proposed monolithic island locations with the proper color pavement marking prior to removal and/or installation. The Design-Build Team shall place drums to delineate existing and/or proposed monolithic islands after the removal and/or before installation.
- 7.9.11. The Design-Build Team shall not place temporary markings other than Cold Applied Plastic Type 4 – Removable Tape on any final pavement surface unless the temporary markings are placed in the exact location of the final pavement markings.
- 7.9.12. Temporary pavement markings on the final concrete surface shall only be removed by hydroblasting.
- 7.9.13. Prior to shifting traffic to a new pattern, the Design-Build Team shall remove all conflicting markings, replace all damaged markings, and remove/replace all

conflicting/damaged markers and snowplowable marker castings.

- 7.9.14. Unless noted otherwise elsewhere in this RFP, removal of the temporary pavement markings on asphalt surfaces shall be accomplished by an NCDOT approved system to minimize damage to the road surface. Unless obscured by pattern masking, temporary pavement markings shall not be obscured with any type of black pavement markings (paint or other material). The Design-Build Team shall remove all temporary pavement markings without removing more than 1/32 inch of the pavement surface.

7.10. Temporary Traffic Signals

- 7.10.1. Use the following notes if the Design-Build Team proposes temporary traffic signals for maintenance of traffic:

- Notify the Engineer in writing a minimum of two months before a temporary traffic signal installation is required.
- Shift and revise all signal heads as shown on the accepted Traffic Signal Plans.

7.11. Traffic Shifts

All straight line traffic shifts on interstates shall be designed for the full L distance (L=width of traffic shift X speed limit in mph). In addition, solid white line pavement markings shall be used to separate the travel lanes in the straight line traffic shift for any road having 2 or more travel lanes in a direction.

7.12. Traffic Control Supervisor

- 7.12.1. The Design-Build Team shall furnish a Traffic Control Supervisor for the project who is knowledgeable of TMP design, devices and application, and has full authority to ensure traffic is maintained in accordance with the plans and specifications developed by the Design-Build Team.
- 7.12.2. The Traffic Control Supervisor shall be on the project site overseeing all road closures and median crossover operations to ensure traffic control devices are properly installed and adjusted as necessary. The Traffic Control Supervisor shall also make necessary changes to the traffic control operations and aide in the monitoring of traffic queuing.
- 7.12.3. The Design-Build Team shall identify a Traffic Control Supervisor in their Technical Proposal that has the following qualifications:
- A minimum 24 months of On-the-Job Training in supervision and work zone set up and implementation on similar projects.
 - Be certified by responsible party (contractor or NCDOT) to have the required experience and training and is qualified to perform the duties of this position. If certified by the Contractor, a notarized certification letter shall be furnished to the Engineer at the preconstruction meeting. The letter shall state the Traffic Control

Supervisor is qualified, and state that the Traffic Control Supervisor has the authority to ensure traffic is maintained in accordance with the contract documents.

7.12.4. The Traffic Control Supervisor for the project shall perform the following:

- During construction, be available or on call 24 hours per day, 7 days per week to direct/make any necessary changes in the traffic control operations in a timely and safe manner.
- Coordinate and cooperate with traffic control supervisors of adjacent, and overlapping construction projects, as well as construction projects in proximity to the subject project, to ensure safe and adequate traffic control setup is maintained throughout the project at all times, including periods of construction inactivity.
- Coordinate and cooperate with the NCDOT Division Incident Management staff.
- Coordinate and cooperate with the NCDOT Statewide Operations Center (STOC) to ensure proper messages are displayed on the CMSs and DMSs.
- Coordinate with Hospitals, Emergency Medical Services (EMS), Fire Departments, and Law Enforcement throughout construction to alert these entities to traffic control impacts that may affect their services.
- Provide traffic control setup that ensures safe traffic operations and workers' safety throughout the construction area.
- Attend all scheduled traffic control coordination meetings, as required by the Engineer.
- Monitor traffic delays and backups within the work zone.

7.13. Lighting

7.13.1. The Design-Build Team shall provide portable temporary construction and equipment lighting to conduct night work in accordance with the 2018 NCDOT *Standard Specifications for Road and Structures*.

7.13.2. For work zones along NC-55 Bypass, furnish and install Sequential Flashing Warning Lights on drums used for merging tapers to assist motorist in determining which direction to merge and to decrease late lane merging. (Reference the Sequential Flashing Warning Lights Project Special Provisions found elsewhere in this RFP).

7.14. Law Enforcement

7.14.1. Law enforcement officers shall be used during any rolling road block operation and to direct traffic when installing/removing/shifting traffic signal heads at intersections. Law enforcement officers may be used to maintain traffic through the work area and/or intersections. The use of law enforcement officers shall adhere to the following requirements:

- The Design-Build Team shall be responsible for coordinating with the law enforcement agency for the use of law enforcement officers.

- The Design-Build Team shall only utilize officers who are outfitted with law enforcement uniforms and marked vehicles, which are equipped with proper lights mounted on top of the vehicle and agency emblems.
- The Design-Build Team shall coordinate with the Engineer where and how law enforcement officers will be used during construction.

7.14.2. The Design-Build Team shall address where and how law enforcement officers will be used in the Technical Proposal.

7.15. Work Zone Speed Limit Reduction

A Work Zone Speed Limit Reduction will not be granted for this project.

7.16. Temporary Shoring for the Maintenance of Traffic

7.16.1. The Design-Build Team shall be responsible for all required temporary shoring, including, but not limited to, designing, providing, installing, maintaining and removing. Temporary shoring for the maintenance of traffic shall be defined as shoring necessary to provide lateral support to the side of an excavation or embankment parallel to an open travelway when a theoretical 2:1 (H:V) slope from the bottom of the excavation or embankment intersects the existing ground line closer than five feet from the edge of pavement of the open travelway. The Design-Build Team shall identify locations where temporary shoring for maintenance of traffic will be required on the Transportation Management Phasing Concept. The Design-Build Team shall install temporary traffic barrier as shown on the *PCB at Temporary Shoring Locations* detail available on the Work Zone Traffic Control website noted below. The aforementioned detail provides design information on the temporary traffic barrier location in relation to the temporary shoring and traffic location. (Notes related to Temporary Shoring are not required in the General Notes sheet for the TMP)

7.16.2. The NCDOT Geotechnical Engineering Unit and Work Zone Traffic Control websites have more information on temporary shoring. The Design-Build Team shall adhere to the additional shoring requirements located on the websites noted below:

<https://connect.ncdot.gov/resources/Geological/Pages/default.aspx>

<https://connect.ncdot.gov/projects/WZTC/Pages/default.aspx>

7.16.3. The Design-Build Team shall identify on the appropriate traffic control details where temporary shoring will be used by providing station limits, offsets, cut sections, the type of shoring and where temporary traffic barrier will be located, if needed.

7.17. Coordination

7.17.1. At a minimum, the Design-Build Team shall coordinate with all Contractors and NCDOT Resident Engineers in charge of any project in proximity to this project for any work that may affect the construction, traffic operations, and/or placement of temporary

traffic control devices (including advanced warning signs) on all roads within the project limits or in conjunction with this project.

- 7.17.2. At a minimum, the Design-Build Team shall coordinate with the Division Traffic Engineer, the Rail Division, Law Enforcement, Emergency Services and the Work Zone Traffic Control Section to schedule and attend Traffic Safety and Operations Meetings. These meetings shall be held to monitor and assess safety and mobility during construction. The Traffic Safety and Operations Meetings shall be held on an as needed basis during project construction. Additional Traffic Safety and Operations Meetings shall be held to address any specific issue, as directed by the Engineer.

7.18. Miscellaneous

- 7.18.1. The Design-Build Team shall provide proper drainage for all temporary alignments and/or traffic shifts.
- 7.18.2. All traffic control devices, including bridge barrier rails, shall be placed/located a minimum two-foot offset (shy distance) from the edge of an open travel lane.

PAVEMENT MARKINGS SCOPE OF WORK

(10-18-18)

1. GENERAL**1.1. Final Pavement Marking Plan Requirements**

- 1.1.1. The Design-Build Team shall prepare Final Pavement Marking Plans in accordance with the latest edition of the Manual on Uniform Traffic Control Devices (MUTCD) effective on the Technical Proposal submittal date, the 2018 NCDOT Roadway Standard Drawings, the *Guidelines for Preparation of Traffic Control and Pavement Marking Plans for Design-Build Projects*, the *NCTA Design-Build Submittal Guidelines*, and the contract requirements contained herein.
- 1.1.2. The Design-Build Team shall select a Private Engineering Firm (PEF) that has experience designing and sealing Pavement Marking Plans for NCDOT on comparable projects.
- 1.1.3. The Design-Build Team shall develop Pavement Marking Plans that maintain all types of traffic (motorists, bicyclists, and pedestrians within the highway, including persons with disabilities, in accordance with the Americans with Disabilities Act of 1990 (ADA), Title II, Paragraph 35.130) as defined by the *Manual for Uniform Traffic Control Devices (MUTCD)*.
- 1.1.4. If sidewalk is constructed, the Design-Build Team shall show and station all curb ramps in the Pavement Marking Plans for signalized intersections, non-signalized intersections and points of pedestrian crossings. Curb ramps shall be constructed per current ADA standards and with guidance from the 2018 NCDOT Roadway Standard Drawings. If the roadway geometry does not allow for the use of standard details, contact the Contract Standards and Development Unit for alternate approved curb ramp designs.

1.2. Final Pavement Marking Project Limits

- 1.2.1. The Design-Build Team shall install all pavement markings and markers located within and outside the project limits, resulting from the project construction. The Final Pavement Marking Plans shall address all required modifications to existing pavement markings and markers located outside the project limits to ensure appropriate tie-ins. At a minimum, the Design-Build Team shall modify existing pavement markings and markers located outside the project limits to ensure that all lanes in each direction are open to traffic, including, but not limited to, to and from the adjacent R-2721B project and the existing Triangle Expressway.

1.3. Pavement Markings, Markers and Delineation

- 1.3.1. The Design-Build Team shall submit a complete set of Final Pavement Marking Plans that includes the -L- Line, and all -Y- Lines, ramps/loops, and service roads for review and acceptance. The Design-Build Team shall not place any final pavement markings or markers until the aforementioned Final Pavement Marking Plans are reviewed and accepted by the Department.
- 1.3.2. The Design-Build Team shall coordinate with the Transportation Management Plans for necessary traffic control devices that will remain at the completion of the project.
- 1.3.3. The Design-Build Team shall use pavement marking and marker products that conform to all NCDOT requirements and are listed on the NCDOT's Approved Products List. The use of any devices that are not shown on the Approved Products List shall require written approval from the NCDOT Signing and Delineation Unit prior to incorporation.
- 1.3.4. The Design-Build Team shall install pavement markings and markers in accordance with the *2018 NCDOT Standard Specifications for Roads and Structures*, and in accordance with the manufacturer's procedures and specifications.
- 1.3.5. In accordance with the NCDOT Roadway Standard Drawing No. 1205.08, Sheet 1 of 8, and guidance found on the Signing and Delineation Unit's webpage, the Design-Build Team shall install wrong-way ramp arrow pavement markings and markers on all exit ramps/loops.
- 1.3.6. The Design-Build Team shall install pavement markings and pavement markers on the final surface as follows:

	Marking	Marker
Asphalt Surfaces	Extruded Thermoplastic	Travel Lanes <ul style="list-style-type: none"> • Snowplowable Markers on Mainline • Match existing on all other roadways Bridge Decks
Concrete Surfaces	Polyurea With Highly Reflective Media	<ul style="list-style-type: none"> • Raised Markers on Mainline • Match existing on all other roadways

- 1.3.7. In accordance with the Black – White Combination (10' White Skip Lines/10' Black Skip Lines) Detail provided by the Department and the Epoxy Pavement Marking Material Project Special Provision found elsewhere in the RFP, the Design-Build Team shall place black epoxy contrast markings on concrete pavement. For bridge decks install Black – White Combination preformed plastic markings.

- 1.3.8. On concrete surfaces, the Design-Build Team shall install Heated-in-Place Thermoplastic or Cold Applied Plastic (Type II or III) markings for stop bars, symbols, characters, crosswalks, and diagonals.
- 1.3.9. On asphalt surfaces, the Design-Build Team shall install Heated-in-Place Thermoplastic or Extruded Thermoplastic markings for stop bars, symbols, characters, crosswalks, and diagonals.
- 1.3.10. Prior to placing pavement marking material on concrete surfaces that are diamond ground, the Design-Build Team shall use an acceptable method to grind ridges smooth only where pavement markings will be installed.
- 1.3.11. On all Full Control of Access Interstate facilities, US Routes, and NC Routes the Design-Build Team shall install six-inch wide pavement markings, (i.e., lane line, edge line and skips) for the final pavement marking. The Design-Build Team shall install gore lines that are twice the edge line width.
- 1.3.12. Using approved methods, the Design-Build Team shall remove residue and surface laitance on concrete bridge decks prior to placing final pavement marking materials. In accordance with approved methods and the *2018 Standard Specifications for Road and Structures*, the Design-Build Team shall remove curing compound from all other concrete surfaces prior to placing final pavement marking materials.
- 1.3.13. The Design-Build Team shall plan and perform their operations to minimize damage to existing and proposed pavement resulting from the removal of pavement markings.
- 1.3.14. The Design-Build Team shall tie proposed pavement marking lines to existing pavement marking lines. The Design-Build Team shall replace any pavement markings that have been damaged by the end of each day's operation.

ALL-ELECTRONIC TOLLING TOLL ZONE INFRASTRUCTURE SCOPE OF WORK

(12-14-18)

1. GENERAL

This All-Electronic Tolling (AET) Toll Zone Infrastructure Scope of Work includes the design, engineering, fabrication, delivery and erection of gantries, AET Toll Zone Vaults, pavement, concrete pads, sidewalks, electrical work, heat, ventilation, air conditioning (HVAC) work, conduit duct banks and associated junction boxes necessary for the infrastructure of the AET tolling system.

1.1. Design Standards

- 1.1.1. The AET Toll Zones shall be designed and constructed in conformance with the most recent version of the *NCTA AET Standard Drawings* provided by NCTA and posted to the R-2721A Connect site. The design and construction shall also conform to the *Complete 540 Aesthetic Design Guidelines* provided by NCTA.
- 1.1.2. The Design-Build Team shall coordinate with the NCTA in the final design and construction of the AET Toll Zone to readily accommodate the TSI's components without the need for modifications and to achieve the NCTA tolling performance requirements. Some information contained within this AET Toll Zone Infrastructure Scope of Work and the *NCTA AET Standard Drawings* is typical and may not be applicable for the specific tolling system provided by the TSI. The Design-Build Team shall consider all local conditions and proposed tolling equipment, and produce the best possible fully engineered design for conduits, boxes and pads to support the integration of the roadside toll AET equipment. However, based upon coordination with the TSI in the final design of the AET toll zone there may be a reduction, deletion or addition of items indicated within this scope of work, which if allowed and necessary, shall result in compensation adjustments in accordance with the 2018 *Standard Specifications for Roads and Structures*.
- 1.1.3. The NCTA will enter into an agreement with a Toll Systems Integrator (TSI), to design, develop, install, test and operate the roadside toll AET equipment for the project.

1.2. Deliverables

- 1.2.1. Design, construction drawings, As-Builts Plans, details, and specifications described within this Scope of Work shall be the responsibility of the Design-Build Team, unless noted otherwise. Provide all details and plans consistent with industry standards and professional requirements. Accurate As-Built Plans shall be provided to the NCTA at the completion of work indicating all AET Toll Zone infrastructure elements installed with accurate locations indicated.
- 1.2.2. Provide NCTA, via the Design-Build Unit, a binder containing equipment installation / maintenance manuals, warranty information, etc. for all installed equipment. Provide electronic copies of this material on CD or DVD with the binder.
- 1.2.3. Provide NCTA, via the Design-Build Unit, four (4) sets of keys to all doors and cabinets.

2. AET TOLL ZONE LOCATION

2.1. General Location

- 2.1.1. Locate each AET Toll Zone at the general locations for Proposed Toll Gantries as depicted on the R-2721A Design Public Hearing Map. Coordinate the final site location for the AET Toll Zones with the NCTA. The final location shall be approved by the NCTA prior to proceeding with final design drawings. The Design-Build Team shall provide GPS coordinates of preliminary design toll zone locations to the NCTA for review and acceptance prior to developing the final design. A Radio Frequency (RF) Spectrum Analysis will then be performed by the Department to determine whether or not the proposed AET Toll Zone is free from electromagnetic conditions that may cause interference with the Radio Frequency Identification (RFID) technology. The Department will need a minimum of six (6) weeks to conduct the survey and report on the results. If interference is found, the Design-Build Team shall re-locate the AET Toll Zone.
- 2.1.2. Locate AET Toll Zones away from sources of Electro Magnetic Interference (EMI) including electrical power supply transformers, motors, Magnetic Resonance Imaging (MRI) and X-ray equipment, radio transmitters, radar transmitters, and induction heating devices to minimize interference with future communications cabling.
- 2.1.3. Locate all AET Toll Zones in roadway areas where lane changing and weaving would not be expected. Do not locate AET Toll Zones under structures or on structures.

2.2. Specific Toll Zone Location and Geometric design

- 2.2.1. NCTA prefers that the AET Toll Zone be located in a minimum 250-foot long horizontal tangent section starting at least 100 ft. prior to the first gantry and extending to at least 100 ft. beyond the second AET gantry structure centerline.
- 2.2.2. In the event the AET Toll Zone cannot be located in a horizontal tangent section, it may be located in a horizontal curve section with a radius of 2,000 feet or greater.
- 2.2.3. Provide uniform AET Toll Zone pavement cross-slopes across the AET Toll Zone travel lanes. The cross-slope shall not exceed 2 vertical feet over the width of the section at the tolling point; for the purpose of this requirement, the "width of the section" shall be defined as the distance between the centerlines of the median shoulder and outside shoulder.
- 2.2.4. The toll zone locations shall accommodate the shoulder acceleration and deceleration lengths required for access to / from the AET Toll Zones.
- 2.2.5. Protect access drive and gantry columns with guardrail as shown in the *NCTA AET Standard Drawings*.
- 2.2.6. Do not place drainage (or other) pipes under the area between the first and second gantries or within 25 feet of any conduit or junction box. The design and construction shall ensure

that surface stormwater shall be directed away from all in-ground junction boxes and equipment pads. The AET Toll Zone design shall be closely coordinated with the roadway design. Shoulder gutter or curb may be needed to assure stormwater is directed away from the junction boxes and equipment pads.

3. AET TOLL ZONE VAULTS

3.1. Location

- 3.1.1. Do not locate the AET Toll Zone Vaults ("Vaults") adjacent to areas that may be subject to the infiltration of water, steam, humidity, heat or other adverse atmospheric or environmental conditions. Avoid site locations that are below water level or near ponding water resulting from rainfall events. Grade the AET Toll Zone site such that water flows away from the Vault. Do not locate Vaults adjacent to sources of constant, excessive, low or high frequency noise, such as air-handling equipment, pumps, and the like.
- 3.1.2. Do not install equipment and utilities not specifically required for the Vaults, including utility pipes, wiring, cabling, ductwork or other electrical equipment within, through, or under the Vault.
- 3.1.3. Coordinate final positioning of the Vault at each site with the NCTA.

3.2. General Configuration

- 3.2.1. Design, engineer, fabricate and erect a Vault for each AET Toll Zone as shown in the *NCTA AET Standard Drawings*. Each Vault shall house ITS equipment and roadside toll collection equipment to be provided by the TSI.
- 3.2.2. Design Vaults to be typical in functionality and appearance throughout the project limits. Provide Vaults of concrete construction that are aesthetically consistent with the existing vaults on the Triangle Expressway. Provide prefabricated, pre-cast or conventional on-site construction. Steel, masonry and / or wood construction will not be allowed. Provide durable, watertight, secure, Vaults requiring minimal maintenance. Provide a roofing system with a minimum 20-year warranty. Residential type shingles will not be allowed.
- 3.2.3. Design finish ceiling height to be not less than 9 feet as measured from the finished floor elevation. The Vault shall have a minimum R-24 insulation.
- 3.2.4. Design Vaults for a two-hour fire rating, unless superseded by the North Carolina Fire Code standards. Provide a 10-pound Class ABC fire extinguisher rated for the size of the Vault mounted at the entrance wall.
- 3.2.5. The Vault shall be watertight and not allow water intrusion in extreme weather conditions. All conduit and utility penetrations shall be sealed watertight. The Design-Build Team shall test the Vault upon completion to verify the entire assembly is watertight.

3.3. Architectural Plans

Prepare an architectural plans package for the AET Toll Zone Vaults, to include the Architectural, Structural, Electrical, HVAC and Mechanical Plans, finish schedule and other documents necessary for a complete turnkey construction of the AET Toll Zone Vaults. Submit design calculations including structural, foundations, HVAC and electrical calculations for all components of the AET Toll Zone Vault with plans. A professional engineer registered in the state of North Carolina shall seal all designs, plans and calculations. Design AET Toll Zone Vaults to meet all zoning code requirements. Prepare the AET Toll Zone Vault plans and designs in accordance with the North Carolina Building Code, latest edition. Provide facility plans that are accurate, legible, and complete in design, drawn to appropriate scales and furnished in reproducible form. Obtain all required permits to construct and occupy the AET Toll Zone Vaults, including those required by the State Construction Office.

3.4. HVAC

- 3.4.1. Furnish AET Toll Zone Vaults with one HVAC unit. The Design-Build Team shall design the HVAC system in coordination with the TSI. Current heat load requirements provided by the TSI require a minimum of a 2-ton HVAC unit. These load requirements are based upon anticipated toll collection and ITS equipment. Actual heat loads to be used in design of the HVAC system shall be confirmed with the TSI.
- 3.4.2. Provide a dual set point (heat and cool) thermostat and install heating and cooling ducts to minimize interference with wall surface area and conflicts with electrical and communication conduits, cable trays, and cabling.
- 3.4.3. Provide method of routing condensate away from base of building.

3.5. Doors

- 3.5.1. Provide exterior access doors that swing outward as shown in the *NCTA AET Standard Drawings*. Provide exterior doors constructed of steel with steel frames. Design and install exterior door, including hollow door jamb, to accommodate future access-control keypads and proximity card readers, which will be installed by the TSI. Provide keyed door locks for interim / back-up security. Provide a universal key that accesses all locks. Provide door construction to suitably protect, seal, and prevent the ingress of water, moisture, dust, gases and wind-driven rain into the Vaults.
- 3.5.2. Doors, frames and hardware shall be extra heavy duty, full flush as defined in SDI A250.8 and shall have a minimum two-hour fire rating in accordance with ANSI/UL 10C, "Positive Pressure Fire Tests of Door Assemblies", unless superseded by the North Carolina Fire Code Standards.
- 3.5.3. Doors to the Vault shall be unobstructed such that a vehicle or portable lift could access the Vault.

3.6. Interior Finishes

Provide interior walls and ceiling fully sealed and painted with a durable high-quality paint. The interior finish color shall be high, bright white semi-gloss. Provide industrial anti-static non-slip tile or an epoxy flooring material.

3.7. Lighting

- 3.7.1. Provide interior lighting consisting of LED commercial lighting fixtures with wall-mounted occupancy sensor and manual on / off. Provide a minimum 50 foot-candles of illumination at a 30-inch work plane. Provide battery operated backup emergency packs with integral halogen heads at entrance / exit. Provide lighting point-by-point calculations for interior lighting as part of Architectural Plan submittal.
- 3.7.2. Provide motion sensor control, exterior lighting that provides an average maintained lighting level of 1.0 foot-candle with a uniformity ratio of 3:1 to 4:1 for the access to the AET Toll Zone Vault and the maintenance parking area. Provide full cut-off exterior lighting fixtures as defined by IESNA and that are International Dark-Sky Association (IDA) compliant. Provide lighting point-by-point calculations for exterior lighting as part of the Architectural Plan submittal. Exterior lighting shall not illuminate the roadway in such a way that it would distract drivers. Exposed conduit on the exterior of the vault will not be allowed for the exterior lighting system.

4. AET TOLL ZONE GANTRY DESIGN REQUIREMENTS

4.1. General

Provide two structural gantries at each AET Toll Zone, to be similar in appearance and scale. Design each gantry to span the facility width as indicated on the *NCTA AET Standard Drawings*. Design each gantry with a separate pier in the median; do not connect/consolidate adjacent piers in the median. Design gantries to ensure that the line of sight for cameras, camera lights, and overhead profilers/separators are not obstructed by the structure.

4.2. Design Criteria

- 4.2.1. Design, engineer, fabricate, transport and erect watertight gantry structures to which the TSI will attach the tolling equipment. Design gantries in compliance with the AASHTO 2013 *Standard Specifications for Structural Supports for Highway Signs, Luminaires and Traffic Signals*, 6th Edition using a minimum wind speed of 90 mph.
- 4.2.2. Coordinate with the TSI and the NCTA for the final toll gantry loading and design. Include effect of any projected future roadway widening and additional tolling equipment in load analysis.
- 4.2.3. Provide vertical clearances in accordance with the *NCTA AET Standard Drawings* in order to maintain proper clearances for the toll collection equipment.

- 4.2.4. Design and install gantry spanning truss members as shown in the NCTA AET Standard Drawings. Design the gantry spanning truss members to support TSI equipment without vibration from wind forces or drafts from vehicles passing under the gantry.

4.3. Aesthetics

- 4.3.1. Design and construct gantry structure including scale, materials, color and finish aesthetically consistent with the *Complete 540 Aesthetic Design Guidelines*. The front façade or paneling of the gantry shall conceal all AET Toll Zone tolling equipment (to the extent possible without impairing the tolling accuracy) and cabling from on-coming traffic and shall present a straight and clean visual appearance, which shall not be detracted from by tolling equipment.
- 4.3.2. The aesthetic treatment shall conceal all conduit and cable trays from view of approaching traffic.

4.4. Conduits and Cabling

- 4.4.1. All conduit, risers and cabling requirements shall be coordinated with the TSI and the NCTA.
- 4.4.2. A 12" (H) x 12" (W) divided enclosed NEMA 3R, 4, or 4X weather-tight cable tray shall be located on the top of the truss, concealed by the cladding face. A 24" x 24" x 12" enclosed NEMA 3R, 4, or 4X junction box shall be installed on the end of the cable tray to accommodate connection of the conduits extending up through the column. The extent of the cable tray is shown in the *NCTA AET Standard Drawings*. The cable tray shall accommodate connections where needed to facilitate the running of cables to equipment located at the lane / shoulder centers and lane / shoulder lines. Cable trays and boxes shall be grounded and bonded per NEC. The equipment mounting bar shall extend to cover all current and future lanes and paved shoulders.
- 4.4.3. Provide conduits terminating above the top of the gantry column and at the at-grade control / junction boxes at the base of the gantry as shown in the NCTA AET Standard Drawings.
- 4.4.4. Design communications conduit connections between the conduit at the top of the column and the cable tray junction box to accommodate a minimum 18" cable bend radius. Design power conduit connections between the conduit at the top of the column and the cable tray junction box to accommodate a minimum 6" cable bend radius.
- 4.4.5. Locate hand-holes, stub-outs, junction boxes, or control boxes, for access to equipment cabling and electrical wiring out of view of approaching traffic.
- 4.4.6. For additional junction box requirements, refer to the ITS Scope of Work.

5. AET TOLL ZONE PAVEMENT AND DRIVEWAY

5.1. Driveway and Parking

Design and provide an asphalt driveway / parking area as shown in the *NCTA AET Standard Drawings*. Provide a driveway to the right side of the direction of travel. Use the pavement design for Service Roads in the Pavement Management Scope of Work.

5.2. Mainline and Shoulder Pavement in Toll Zones

- 5.2.1. Alternate 2 specified in the Pavement Management Scope of Work may not be used from a point 200 ft. prior to the first gantry to a point 100 ft. beyond the second gantry.
- 5.2.2. If asphalt pavement is proposed for the mainline, the final lift of asphalt shall be 2" from a point 200' (minimum) prior to the first gantry to a point 100' (minimum) beyond the second gantry. In this area, the surface course shall be 3.5" in lieu of 3.0" as required by the Pavement Management Scope of Work, tapering back to a 3" surface course over a minimum distance of 25 ft. outside the limits above.
- 5.2.3. If concrete pavement is proposed for the L-line pavement, do not use any ferrous material in the pavement throughout the toll zone. For this requirement, the toll zone shall be defined as 30 ft. in advance of the first gantry to 30 ft. past the second gantry. The location of expansion joints may have to be adjusted to avoid AET loops. A sample accommodation can be seen in sheet C-5 of the NCTA AET Standard Drawings. The final loop design will be determined by the TSI.
- 5.2.4. Do not install rumble strips through the toll zone. For this requirement, the "toll zone" shall be defined as 30' in advance of the first gantry to 30' past the second gantry.

6. MISCELLANEOUS AET TOLL ZONE SITE REQUIREMENTS

6.1. Foundation / Sidewalk / Concrete Maintenance Pad

- 6.1.1. As shown in the *NCTA AET Standard Drawings*, construct concrete pads that serve as the Vault foundation (will serve as maintenance pad, sidewalk, etc.) and equipment cabinet foundations. The Vaults and equipment cabinet foundations shall be 8-inches thick minimum. Design and grade site so water flows away from the AET Toll Zone Vault slab and equipment pads.
- 6.1.2. Locate the generator on the AET Toll Zone Vault foundation concrete pad as detailed in the *NCTA AET Standard Drawings*.
- 6.1.3. The AET Toll Zone Vault shall include a 6-inch high curb that separates the foundation from the adjacent parking surface. (Reference the *NCTA AET Standard Drawings* for additional requirements) Provide a ramp from the adjacent driveway centered on the door for loading / unloading. The sidewalk and pad areas shall have a brushed finish.

6.2. Screen Wall

- 6.2.1. Design decorative screening / wall to visually shield the motorist from viewing the Vault and maintenance pad. Provide decorative screening / wall around two sides of the Vault, as shown in the *NCTA AET Standard Drawings*.
- 6.2.2. Design decorative screening / wall consistent with the *Complete 540 Aesthetic Design Guidelines*.
- 6.2.3. Between the wall and the Vault, provide a washed stone (#57) surface to facilitate drainage and maintenance of conduit entering the Vault.

6.3. AET Toll Zone Conduit and Junction Boxes

- 6.3.1. Design and construct required conduits and cabling infrastructure necessary to establish the communications path between fiber-optic trunk line, Vaults, gantries, cabinets, and junction boxes. Install the number and size of conduits, boxes and related equipment specified in the ITS Scope of Work found elsewhere in this RFP and the *NCTA AET Standard Drawings*. Coordinate with the NCTA throughout the conduit and junction box design and installation.
- 6.3.2. Ensure junction boxes are provided such that the last set of junction boxes before a conduit route enters a vault are not placed higher in elevation than the vault slab itself. This will prevent water-filled boxes from draining into the vault.
- 6.3.3. Provide separation between power and communications conduit as specified in the *NCTA AET Standard Drawings*.
- 6.3.4. Provide underground concrete-encased conduit duct bank when crossing new roadways. Install conduit duct banks such that there is a minimum of 18 inches of cover from pavement subgrade to the top of the duct bank. Trenched conduit, directional bores or jack and bore shall be in accordance with the 2018 *Standard Specifications for Roads and Structures*.
- 6.3.5. Terminate conduit through the floor slab of AET Toll Zone Vaults above finished floor elevation. Conduit ends shall be 18" minimum above the vault floor.
- 6.3.6. Furnish conduits stubbed out at all concrete pads with plastic bushings (or comparable material) to prevent cables from being damaged when being pulled through conduits or shifting during use. Clearly label each end of the conduits and include conduit plugs, pull line in each conduit, and tracer wire (if needed) per Article 1091-3 of the 2018 *Standard Specifications for Roads and Structures*.
- 6.3.7. Provide galvanized metallic conduit in above ground installations.

6.4. Electrical

Provide building electrical power to lights, switches, receptacles, HVAC system and other

infrastructure items for operating and managing the Vault. Coordinate with the TSI and the NCTA to establish electrical power and communication / data service requirements for each toll gantry. Coordinate with the TSI and the NCTA in the design of the electrical loading, ampere capacity rating, circuit poles, etc. for the final power panel design.

6.4.1. Provide electrical service to the Vaults in accordance with the following:

- 120/240V single-phase service.
- operating voltage of 120/240V, at a minimum, 400 amps, unless otherwise approved.
- electrical power panel in a conventional NEMA 1 surface mount panel board enclosure, which supplies power to the electronic toll equipment.
- a minimum 400-amp Main Breaker with a minimum of 42 circuits.
- a minimum of two (2) two-pole breakers coordinated with the Toll System Integrator (typically 50 or 80 amps) and the remaining breakers at 20 amps rated at minimum 18K AIC.
- a main ground bus bar connected to the building grounding system
- If power is provided from a single point for multiple Vaults or locations, a Main Distribution Panel may be necessary.

6.4.2. Provide the Vaults with 125 volt rated duplex receptacles at approximately 10-foot centers at 18 inches above finished floor, as shown on the *NCTA AET Standard Drawings*. Field-adjust, as needed, to accommodate the conduit risers.

6.4.3. Coordinate with the local utility company(ies), make application(s) in the name of NC Turnpike Authority, and pay all deposit fees to provide necessary electrical and communication services for the AET Toll Zones. The Design-Build Team shall be responsible for all application and connection fees. The Design-Build Team shall be responsible for any utility service installation from the power meter to the Vaults' power panels. The Design-Build Team will not be responsible for paying the monthly power bills.

6.4.4. Perform all electrical work in conformance with the latest edition of the National Electric Code. Note that the toll zone vault is classified as a "Modular Data Center"

6.5. Grounding

Provide a master grounding system at all new and revised Vault electrical service points, unless otherwise specified. In addition to National Electrical Code (latest edition) requirements, test grounding electrode resistance at connection point to electrical service ground bus for a maximum of 20 ohms. Furnish and install additional ground rods to grounding electrode system as necessary to meet test requirements. Submit a completed Grounding Test Results form. Provide a length of marker tape 12-inches below finished grade directly over grounding electrodes and conductors.

6.6. Lightning Protection

Design and install Lightning Protection System for the Vaults and Gantries in conformance with, and certified by, the Lightning Protection Institute (L.P.I.) Installation Code LPI-175. Products shall comply with Underwriters Laboratories, Inc. Master Label Code 96A and NFPA 780. The lightning protection system installer shall submit a UL Master Label or L.P.I. system certification upon completion of the work. Design Lightning Protection System taking into account all tolling equipment to be installed on gantry. Consider equipment installed on the Triangle Expressway's Salem Street interchange ramp toll sites as indicative of equipment to be installed at these sites. Coordinate with the TSI on actual equipment to be installed.

6.7. Standby Generator

- 6.7.1. Provide standby generator to power each complete AET Toll Zone to include Vaults, toll and communications equipment, video tolling cameras and lights, sensors, DMS on gantries, lighting, electrical system, security system, monitoring and HVAC systems. Supply and install a 60kW standby generator. Provide a generator disconnect as per the *NCTA AET Standard Drawings*.
- 6.7.2. Where toll zone configurations differ from those shown in the *NCTA AET Standard Drawings*, alternate sizing shall be necessary and shall be coordinated with the NCTA.
- 6.7.3. Provide standby generator with an automatic transfer switch designed to run after 5 seconds of power outage. Evaluate and include a method for reducing the noise impact caused by the standby generators to residences near proposed Vault locations.
- 6.7.4. The standby generator shall be provided with an outdoor-rated housing and mounted on the concrete pad adjacent to the Vault with clearances as shown on the *NCTA AET Standard Drawings*, unless additional clearance is required by code or manufacturer's recommendation. Include a muffled exhaust system for the generator.
- 6.7.5. Provide a protective screen against rodents at the base of the generator.

6.8. Propane Tank

- 6.8.1. Provide a single 1000-gallon propane fuel tank with a dry level sensing device (hard-wired, 4-20mA, 0-5 VCD or 0-10 VDC typical Hall Effect Transmitter) that will interface with future Vault automation system provided by others.
- 6.8.2. Install a transfer switch to interact and directly communicate via contact closures with building automation system for critical status indications.
- 6.8.3. Provide TSI with Interface Control Documents (ICDs) as a part of construction submittals for generator, transfer switch, and propane tank to facilitate communications.
- 6.8.4. Design propane fuel tank system compliant with all local, State, and Federal requirements and comply with NFPA 54, National Fuel Gas Code.

- 6.8.5. The Design-Build Team shall take measures to ensure standing water does not accumulate in access hatch.
- 6.8.6. All wiring from the building interior to the generator and the propane shall be continuous and free of splices.

SIGNING SCOPE OF WORK

(1-10-18-1819)

1. PROJECT SIGNING LIMITS**1.1. Signing Project Limits**

- 1.1.1. Unless noted otherwise in this Scope of Work, the Design-Build Team shall prepare Signing Plans for the entire roadway limits of the Project, including but not limited to advance and other necessary signing outside of the roadway construction limits.
- 1.1.2. Unless noted otherwise elsewhere in this RFP, the Design-Build Team shall design, fabricate and install all Type A, B, D, E, and reference mile marker signs and supports (including overhead sign structures) required through the construction limits of the mainline, as well as all -Y- Lines, all service roads, all turn-arounds / cul-de-sacs, and all ramps and loops. Unless noted otherwise elsewhere in this RFP, the Design-Build Team shall design, fabricate and install all signs and sign supports (including overhead sign structures) required beyond the roadway construction limits of the mainline, all -Y- Lines, all service roads and all turn-arounds / cul-de-sacs to ensure adequate advance signage and spacing is provided, including but not limited to signs within the adjacent existing NC 540 roadway and R-2721B Project.
- 1.1.3. The Design-Build Team shall not be responsible for the design and installation of any signage east of the eastern project termini (within the R-2721B project limits). However, the Design-Build Team shall coordinate with the NCTA and R-2721B Design-Build Team to ensure the signing plans are complete in the vicinity of the NC 55 and Holly Springs interchanges, respectively.

1.2. Sign Locations

- 1.2.1. The Design-Build Team shall determine the location of all signs and sign structures.
- 1.2.2. The Design-Build Team shall provide a minimum of two advance guide signs for all freeway / expressway interchange approaches.
- 1.2.3. To avoid placing a sign or sign structure in a location that might be in conflict with future roadway projects and / or limit its usefulness / lifespan, the Design-Build Team shall coordinate all proposed sign designs and locations with the Department.
- 1.2.4. Erection of signs on Toll Gantries will not be allowed.

2. SIGNING DESIGN**2.1. Signing Schematic**

- 2.1.1. The Design-Build Team shall prepare Signing Plans in accordance with the R-2721A *Signing Schematic* dated ~~May 24, 2018~~ January 11, 2019 ("*Signing Schematic*") and the

NCTA Toll Road Signing Typical Layouts and *NCTA Toll Signing Details* dated May 3, 2018. The Design-Build Team shall use the *Signing Schematic*, in conjunction with all applicable standards, to develop the Signing Plans. To minimize right of way, utility, drainage and / or jurisdictional impacts, or to install a sign behind existing guardrail, the Design-Build Team will be allowed to shift signs shown on the aforementioned *Signing Schematic* and *NCTA Toll Road Signing Typical Layouts* and *NCTA Toll Signing Details* a maximum of 100 feet. To meet all applicable standards, the Design-Build Team shall replace / relocate all existing signs affected by the project, as well as provide all required additional signs, not shown on the aforementioned Signing Schematic.

- 2.1.2. In accordance with the roadway design developed by the Design-Build Team, the Design-Build Team shall develop a signing concept that adheres to the aforementioned *Signing Schematic* and *NCTA Toll Road Signing Typical Layouts* and *NCTA Toll Signing Details*. Any deviations from the Signing Schematic are subject to the NCTA's approval.

2.2. Signing Concept and Preliminary Plans

- 2.2.1. The Design-Build Team shall include a Preliminary Signing Concept Map in the Technical Proposal. At a minimum, the aforementioned Concept Map shall include all anticipated DMS locations, and all proposed overhead sign structure locations, overhead signs and ground mounted guide signs.
- 2.2.2. Prior to submitting the 50% Preliminary Signing Plans, the Design-Build Team, the Division Traffic Engineer, the Regional Traffic Engineer, the Signing and Delineation Regional Engineer and the NCTA shall meet to discuss and review the Design-Build Team's 25% Preliminary Signing Plans.
- 2.2.3. The Design-Build Team shall provide 25% Pavement Markings Plans that have been reviewed and accepted by the NCTA and the latest roadway plans with the 50% Preliminary Signing Plans submittal.

2.3. General Sign Design

- 2.3.1. The Design-Build Team shall include all sign designs in the Signing Plans. All sign designs shall be prepared using the latest version of GuideSign software.
- 2.3.2. The Design-Build Team shall design, fabricate and install all signs required for the mainline, all -Y- Lines, all ramps and loops, all service roads and all turn-arounds / cul-de-sacs, including Type A and B overhead signs, Type A, B, and D ground mounted signs, and exit gore signs. The Design-Build Team shall size and locate all Type E signs (warning and regulatory) and Type F signs (route marker assemblies). All Toll Route Signs shall be Type B assemblies with 36" high route markers.

2.4. Prequalification

The Design-Build Team shall select a Private Engineering Firm (PEF) that has experience in the preparation, design, and sealing of Signing Plans for NCDOT on comparable projects.

2.5. Mile Markers

- 2.5.1. The Design-Build Team shall design, fabricate and install enhanced mile markers at **two tenths (0.2 mile)** intervals along both sides of the mainline. The Design-Build Team shall install each mile marker on one three-pound U-channel post. Mile markers shall be located at the outside shoulder point or a maximum of 15 feet from the edge of travel lane. The Design-Build Team shall install mile markers such that the bottom of the mile marker shall be four feet above the edge of travel lane (edgeline) elevation. Excluding whole mile locations, mile marker designs shall be in accordance with the Intermediate Reference Location Signs (D10-2a) referenced in the *Standard Highway Signs* (2004 Edition and the 2012 Supplement to the 2004 Edition). At whole mile locations, mile marker designs shall be in accordance with the Reference Location Signs (D10-2) referenced in the *Standard Highway Signs* (2004 Edition and the 2012 Supplement to the 2004 Edition).
- 2.5.2. The Design-Build Team shall design, fabricate and install mile markers and exit numbers in accordance with the mile numbers provided by the Department.

2.6. Electronic Toll Collection Signing

The Design-Build Team shall be responsible for the design, fabrication, and installation of all toll road signs in accordance with the *NCTA Toll Road Signing Typical Layouts* and *NCTA Toll Signing Details* dated May 3, 2018. The background for toll guide signs shall be green. Electronic Toll Collection Signing logo pictographs, details provided by NCTA, shall be used on the ETC signs. Design of signs containing logos shall be in accordance with Chapter 2F of the *MUTCD*.

2.7. Customer Service Center Signing

The Design-Build Team will not be responsible for the design, fabrication, and installation of any customer service center signing.

2.8. Speed Limit

The posted speed limit for the mainline (NC-540) shall be 70 mph.

2.9. Interstate, US, and NC Route Designation

The designated route for the mainline shall be NC 540. All interstate, US and NC highway routing shall be coordinated within the Traffic Mobility and Safety Division of NCDOT. Prior to designing any signs that display new or revised Interstate, US or NC routes, the Design-Build Team shall confirm all highway routes with the Department.

2.10. Miscellaneous Signs

2.10.1. Enhanced ramp reference markers will not be required on ramps or loops.

2.10.2. At all interchange exit loops and / or as required by the MUTCD Table 2C-5, the Design-Build Team shall fabricate and install advisory speed signing as shown in Figure 2C-3 of the MUTCD. In addition to signing shown in Table 2C-5 of the MUTCD, the advisory speed signing shall include W13-6, W13-7, W1-13, and E13-1P signs including under E5-1a.

2.10.3. The Design-Build Team shall design, fabricate and install 30" x 36" Chevron Alignment signs (W1-8) along all interchange loops. Each Chevron Alignment sign shall be:

- installed on two U-channel posts spaced 24" apart with cross bracing
- located and installed so the bottom of the sign is four feet above the edge of the travel lane elevation (left edge of the loop)

2.10.4. The first Chevron Alignment sign shall be installed as close as practical after the exit gore sign (approximately 20' from the exit gore sign), and shall not interfere with or block the exit gore sign. The first five Chevron Alignment signs shall be spaced approximately 40' apart and oriented to optimize the view of approaching motorists. After these first five Chevron Alignment signs, or beyond the midpoint of the curve, Chevron Alignment sign spacing shall adhere to the MUTCD requirements.

3. PRINCIPLE STANDARDS AND REFERENCES

3.1.1. The Design-Build Team shall prepare Signing Plans in accordance with the information on the following websites, the version of the following references effective on the Technical Proposal submittal date and the contract requirements contained herein:

- The Signing and Delineation Unit website:

<https://connect.ncdot.gov/resources/safety/Pages/Signing-and-Delineation.aspx>

- Traffic Engineering Practices, Policies, and Legal Authority (TEPPL):

<https://connect.ncdot.gov/resources/safety/Teppl/Pages/Teppl-Select-Topics.aspx>

- *Manual on Uniform Traffic Control Devices* (MUTCD):

http://mutcd.fhwa.dot.gov/kno_2009r1r2.htm

- *2009 NC Supplement to the Manual on Uniform Traffic Control Devices*:

<https://connect.ncdot.gov/resources/safety/TrafficSafetyResources/2009%20NC%20Supplement%20to%20MUTCD.pdf>

- *LRFD Standard Specifications for Structural Supports for Highway Signs, Luminaires, and Traffic Signals* (AASHTO):

https://bookstore.transportation.org/Item_details.aspx?id=2369

- *Guidelines for Preparation of Signing Plans for Design-Build Projects*

<https://connect.ncdot.gov/letting/Pages/Design-Build-Resources.aspx>

- *NCTA Design-Build Submittal Guidelines* located on the Teamsite for the R-2721A Project.
- 2018 NCDOT *Standard Specifications for Roads and Structures*
- 2018 NCDOT *Roadway Standard Drawings*

3.1.2. In the case of conflicting design parameters, and / or ranges, in the various resources, the proposed design shall adhere to the most conservative values, unless noted otherwise elsewhere in this RFP.

4. OVERHEAD SIGNS AND SUPPORTS

4.1. Sign Sheeting Requirements for Overhead Signs

4.1.1. The Design-Build Team shall design and fabricate all overhead signs with Grade A retro-reflective sheeting for sign legends (text), borders, and all Interstate, US and NC route shields and arrows. The Design-Build Team shall design and fabricate all overhead signs with Grade C retro-reflective sheeting for the background.

4.1.2. Black non-reflective sheeting shall be used for all black arrows, legends (text), and borders on overhead signs.

4.2. Overhead Sign Structures

4.2.1. The Design-Build Team shall consider the proposed roadway geometry, number of lanes (including one future median lane in each direction), and all advisory signing needs when selecting the type of overhead signing for a given location. At a minimum, the Design-Build Team shall provide overhead signing as shown in the Signing Schematic, at the locations identified in the MUTCD, Section 2E.24 – Signing for Interchange Lane Drops, Section 2A.17 - Overhead Sign Installations, Items A – M, and the following locations, unless allowed otherwise in this RFP:

- An option lane at a freeway / expressway multi-lane exit or freeway / ramp split (use Arrow Per Lane signs)
- A freeway ends and “ALL TRAFFIC EXIT”
- A freeway lane ends (freeway lane drop)
- Three or more lanes on a freeway ramp

- 4.2.2. The Design-Build Team shall locate, design and install overhead sign structures that meet all Department requirements, including the calculation of wind load areas in accordance with the requirements below.
- 4.2.3. The wind speed for the overhead sign structure and foundation designs for this project shall be 100 mph.
- 4.2.4. Overhead Sign Assemblies denoted with an asterisk on the Signing Schematic shall be designed, fabricated and installed in accordance with the *Aesthetics Design Scope of Work*.
- 4.2.5. The Design-Build Team shall design, fabricate and install overhead sign supports and foundations in accordance with Section 906 of the NCDOT *Standard Specifications for Roads and Structures*, the *Foundations and Anchor Rod Assemblies for Metal Poles*, and *Overhead and Dynamic Message Sign Foundations* Project Special Provisions found elsewhere in this RFP.
- 4.2.6. For all overhead sign assemblies mounted on concrete median barrier, the Design-Build Team shall design, fabricate and install median barrier footing and median transitional barrier in accordance with the NCDOT Roadway Standard Drawing No. 854.05.
- 4.2.7. The vertical clearance beneath all proposed overhead sign assemblies shall be no less than 17 feet and no greater than 18 feet. For all proposed overhead sign assemblies, the Design-Build Team shall submit documentation that verifies the actual vertical clearance at all critical points.
- 4.2.8. Except as may otherwise be dictated for the sign panels along I-40, the Design-Build Team shall justify the bottom edge of all primary signs on each assembly in a horizontal plane.
- 4.2.9. The maximum span length for cantilever overhead sign structures shall be 52 feet.
- 4.2.10. Lighting and walkways will not be required on any overhead sign assembly.
- 4.2.11. Overhead signs shall not be attached to existing or proposed bridges.
- 4.2.12. Steel sign hangers shall not extend outside or above proposed sign panels.

4.3. Pedestal Overhead Sign Structures

- 4.3.1. The Design-Build Team has the option to design pedestal overhead sign assemblies for advance guide signs on NC 540 as shown on the *Signing Schematic* as an alternative to cantilever overhead sign assemblies. Signs with exit directional and “EXIT ONLY” designation shall not utilize pedestal assemblies.

- 4.3.2. Pedestal overhead sign assemblies shall have a minimum 20 feet offset from the edge of travel lane to the centerline of the support. The Design-Build Team shall install guardrail or other approved protection for the overhead sign support.
- 4.3.3. The Design-Build Team shall design, fabricate, and install pedestal sign supports and foundations in accordance with the Project Special Provision for Overhead and Dynamic Message Sign Foundations found elsewhere in this RFP.
- 4.3.4. The sign structure and steel sign hangers shall not extend outside or above the proposed sign panel.

4.4. Proposed Overhead Wind Load Area

- 4.4.1. Overhead sign structures shall be designed for proposed and future signs. The designer shall determine wind load areas and include the wind load areas on the overhead sign structure drawings. The wind load area for the sign structures shall be determined to include the area of either Known Future Signs (Case A) or Unknown Future Signs (Case B) according to the following:

Case A: If a future sign is shown on the signing schematic, the future signs shall be included in the calculation of the wind load area. Future sign messages, sizes, and positions shall be shown on the overhead sign structure drawings.

Case B: If a future sign is not shown on the signing schematic, compute the wind load as follows:

- For each primary sign, the wind load area shall be a rectangular area that includes the secondary and supplemental signs and the spacing between the signs according to Roadway Standard Drawing No. 904.20. Temporary “ALL TRAFFIC EXIT” signs do not need to be included in the calculation of wind load area.
- Span and Pedestal Structures: For each primary sign, the wind load area width and height shall be increased by 4 feet (2 feet in all directions of each proposed primary sign).
- Cantilever Structures: For each primary sign, the wind load area width and height shall be increased by 2 feet and 4 feet, respectively.
- Case B does not need to be applied to Arrow Per Lane Signs and Interchange Sequence Signs.

4.5. Existing Overhead Structures

- 4.5.1. Prior to modifying an existing overhead sign assembly to accommodate proposed signs that exceed the original wind load area, the Design-Build Team shall perform a structural analysis of the overhead sign structure. The Design-Build Team shall obtain Department

acceptance of the structural analysis prior to construction. The Design-Build Team shall replace all existing overhead sign assemblies determined to be structurally inadequate for the proposed modifications, in the Department's sole discretion. The Design-Build Team may modify an existing overhead sign assembly to accommodate proposed signs that do not exceed the original wind load area without performing the aforementioned structural analysis.

- 4.5.2. When the aforementioned structural analysis determines that an existing overhead sign structure is structurally adequate to be retained or the proposed wind load area does not require a structural analysis, the Design-Build Team shall remove and dispose of all the existing overhead signs. The Design-Build Team shall install new signs on the retained existing overhead sign structure that adhere to the requirements herein. The Design-Build Team shall prepare Structure Line Drawings that depict 1) the existing signs to be removed, 2) the existing sign sizes, 3) the new sign designs, 4) the vertical clearance of all new signs, 5) the new signs positioning over travel lanes, 6) the lateral placement from supports, 7) the original wind load area, and 8) confirmation that the proposed wind load area does not exceed the original wind load area.
- 4.5.3. If the Department can't provide existing overhead structure line drawings or shop drawings of the existing overhead sign structure, the Design-Build Team shall design and install new overhead sign structures.
- 4.5.4. The minimum vertical clearance beneath all existing overhead sign assemblies that are retained shall be 17 feet. For all existing overhead sign assemblies retained, the Design-Build Team shall submit documentation that verifies the actual vertical clearance at all critical points.

4.6. Shop Drawings for Overhead Sign Structures

The Design-Build Team shall prepare a shop drawing for each proposed and modified overhead sign structure for the Department's review and approval. For shop drawing design and submittal requirements, see *Guidelines for Preparation of Signing Plans for Design-Build Projects* and the *NCDOT Standard Specifications for Roads and Structures*.

4.7. Guardrail or other Positive Protection for Overhead Sign Supports

- 4.7.1. Except as allowed below, overhead sign supports shall be located a minimum of 40 feet from the edge of the outside travel lane to the center of the sign supports. To minimize right of way, utility, drainage and / or jurisdictional impacts, or to allow a cantilever overhead sign assembly in lieu of a full-span overhead sign assembly, the minimum 40-foot offset may be reduced, at the Department's sole discretion. All overhead sign supports that are not located a minimum of 40 feet from the edge of the outside travel lane to the center of the sign support shall be protected by guardrail or other NCDOT approved positive protection barrier. When an overhead sign support is protected by guardrail, the face of the guardrail shall be located a minimum of eight feet from the center of the sign support.

- 4.7.2. The Design-Build Team shall review the protection for all existing overhead structure supports that are retained to determine if the existing positive protection meets current requirements. If the positive protection does not meet current requirements, the Design-Build Team shall design and construct new positive protection that adheres to the current requirements.
- 4.7.3. Cable-guide rail shall not be used as positive protection for overhead sign supports.

4.8. Verification of Theoretical Information shown on Structure Line Drawings

The Design-Build Team shall verify the information on the Structure Line Drawings prior to submittal of shop drawings for the Department's review and acceptance. At a minimum, the aforementioned verification shall include confirmation of the sign(s) positioning over lanes, span length, sign offsets, s drops, and the slopes at the center line of the support / upright. When theoretical dimensions or slopes are revised during construction, the Design-Build Team shall submit a revised Structure Line Drawing with the shop drawing.

5. GROUND MOUNTED SIGN SUPPORTS

5.1. Types A and B

- 5.1.1. The Design-Build Team shall design, fabricate and install ground mounted signs supports in accordance with the NCDOT Roadway Standard Drawings. The associated software for the design of Type A and B ground mounted sign supports, may be referenced on the website noted below:

<https://connect.ncdot.gov/resources/safety/Pages/Signing-and-Delineation.aspx>

- 5.1.2. Prior to installation, the Design-Build Team shall 1) field verify all Type A and B ground mounted sign supports, 2) recalculate the field verified S-Dimensions, using the latest edition of the design software on the website noted above, and 3) revise the beam sections, where applicable. The Design-Build Team shall use the most recent version of the ground mounted sign support selection workbook tool, in accordance with the submittal schedule outlined in the "Instructions" tab of the tool.
- 5.1.3. On freeways and expressways, the minimum lateral offset for Type A and B ground mounted signs on breakaway supports shall be 30 feet, unless approved otherwise by the Department. The lateral offset shall be measured from the edge of the travel lane closest to the shoulder to the closest sign edge.
- 5.1.4. On freeways and expressways, all Type A and B ground mounted signs on simple (non-breakaway) supports shall be protected by guardrail, barrier or another form of approved positive protection. The minimum lateral distance between the face of guardrail and the closest sign edge shall be six feet.

- 5.1.5. Type B route sign assemblies shall be mounted on steel support(s) with foundation(s) designed with the latest steel support design software.

5.2. Types D, E, and F

- 5.2.1. Unless otherwise approved by the Department, the vertical mounting height for ground mounted Type D, E and F signs shall be a minimum of seven feet and maximum of eight feet from the edge of the travel lane to the bottom of the sign.
- 5.2.2. Unless noted otherwise elsewhere in this RFP, all Type D, E and F signs shall be installed on U-channel posts in accordance with the NCDOT Roadway Standard Drawings. Type D signs shall not exceed eight feet in width and / or 24 square feet. Unless positively protected, all Type D signs shall be installed on a maximum of two U-channel posts.

5.3. Location

For all ground mounted sign supports on concrete median barriers, the Design-Build Team shall be responsible for the design.

6. TEMPORARY SIGNS, MAINTENANCE, AND DISPOSAL

6.1. Removal and Disposal of Existing Signs

The Design-Build Team shall determine which existing signs, sign supports, overhead signs, and / or overhead sign supports will not be needed or relevant when the project is completed. The Design-Build Team shall remove and dispose of these signs and sign supports.

6.2. Temporary Sign and Support Design

The Design-Build Team shall locate, design and install all temporary signs and sign supports. (Reference the Signing Requirements Section of the *Transportation Management Scope of Work* found elsewhere in this RFP for additional temporary signing requirements)

6.3. Sign Maintenance

During project construction, the Design-Build Team shall maintain all existing signs within the project limits (including all Logo signs and temporary sign installations that may be required by the Transportation Management Plans) to ensure the signs are in good condition, perform as intended, and are visible to motorists (Reference Articles 901-4 and 1092-2 of the NCDOT *Standard Specifications for Roads and Structures*). All signs and supports remaining / existing at the completion of this project shall be plumb, oriented correctly and adhere to AASHTO requirements.

7. FINAL SIGNING PLANS

7.1. CADD Files

After acceptance of RFC Signing Plans, the Design-Build Team shall provide the final Signing Plans to the NCTA in .pdf and MicroStation format.

7.2. Construction Revisions

After submittal of RFC Signing Plans, the Design-Build Team shall submit all construction revisions to the NCTA for review and acceptance prior to incorporation.

7.3. As-Built Plans

After project completion, the Design-Build Team shall provide final electronic Signing Plans to the Department. At a minimum, these Signing Plans shall include all revisions that occurred during construction, as well as field verifications for ground mounted sign supports and overhead structures. These Signing Plans shall be provided in .pdf and MicroStation format.

RIGHT OF WAY SCOPE OF WORK~~(11-7-18)~~1-10-19)**1. ~~RESPONSILITIES~~RESPONSIBILITIES****1.1. Department Responsibilities Based on Roadway Right of Way Plans**

- 1.1.1. The Department is finalizing Right of Way Plans and will provide those plans to the Design-Build Teams. The Department will hire a firm or firms ("Firm") to acquire the necessary right of way and easements, perform asbestos surveys and abatements and building demolition for this project, unless otherwise stated herein.
- 1.1.2. The Firm will initiate contact with property owners and begin the appraisal and negotiation process during the procurement of this project.
- 1.1.3. After Contract execution, the Firm will continue to acquire the necessary right of way for this project based on the priorities established in writing by the Design-Build Team.
- 1.1.4. After Contract execution, the Firm will prioritize their work as directed by the Design-Build Team. The Firm's fees will be borne solely by the NCTA. Prior to Contract award, the Design-Build Team shall have no direct contact with the Firm regarding this project in any manner except as otherwise permitted by the NCTA.
- 1.1.5. The Department has begun or completed the right of way acquisition of approximately 25 parcels, either as relates to advance acquisition or to settle the Transportation Corridor Map Act (Map Act) active inverse claims on these parcels.
- 1.1.6. In the event that right of way negotiations necessitate a change in the Right of Way Plans prior to contract execution, the NCTA will make the necessary revisions. After contract execution, the Design-Build Team will be responsible for incorporating these revisions. In the event that the revision (1) is not due to any design change made by the Design-Build Team; (2) adds construction features for that property as compared to that shown on the Right of Way plans provided by NCTA (e.g. extra driveway, driveway pipe); and (3) the revision introduces more than \$2,000 in additional construction work, then the NCTA will consider this change in scope as extra work in accordance with Subarticle 104-8(A) of the NCDOT Standard Specifications for Roads and Structures.

2. NCTA RIGHT OF WAY ACQUISITION COMMITMENTS**2.1. Design-Build Team Priority List**

- 2.1.1. The Design-Build Team shall provide a list of priorities for NCTA acquisition of right of way. The list shall contain no more than 60 parcels, with no more than 10 of these involving relocatees.
- 2.1.2. The list shall be submitted as part of the Technical Proposal but may be adjusted for a period of 30 days after Contract award.

2.2. Acquisition Timeframe

- 2.2.1. Unless otherwise noted herein, the Firm will acquire, or otherwise gain right-of-entry to a minimum of 75 parcels, including at least 40 parcels from the Design-Build Team's priority list and the parcels referenced in Section 1.1.5 of this Scope of Work by November 1, 2019 (December 1, 2019 if a parcel includes a relocatee).
- 2.2.2. Unless otherwise noted herein, the Firm will acquire, or otherwise gain right-of entry to a minimum of 150 parcels, including at least 50 parcels from the Design-Build Team's priority list and the parcels referenced in Section 1.1.5 of this Scope of Work by January 1, 2020 (February 1, 2020 if the parcel includes a relocatee).
- 2.2.3. In the event that unknown archaeological sites, hazardous materials, or asbestos abatement requirements are revealed on a parcel, the NCTA may require up to an additional 30 calendar days beyond the dates noted above to gain access to that parcel; however, in such case, consideration will be given for extending the contract time on a calendar day for calendar day basis, subject to the time extension conditions outlined herein.

2.3. Contract Time

- 2.3.1. In the event that the NCTA fails to satisfy the commitments specified in Section 2.2 of this scope of work, the NCTA will entertain requests for additional contract time in accordance with Section 2.3.2 and 2.3.3.
- 2.3.2. If the Design-Build Team demonstrates to the satisfaction of the NCTA that the delay in right-of-way or easement of a parcel or parcels affects their critical path, the contract time will be extended one calendar day for each calendar day delay beyond the timeframe shown above that it takes to acquire the critical parcel. In no case shall further contract time extensions be granted due to further indirect delays (such as weather, seasonal construction limitations, or borrow availability) that may result from the delay in parcel availability.
- 2.3.3. Any change to the initial priority list later than 30 days after Contract award that accelerates the Design-Build Team's expectation for a parcel's availability will nullify this consideration for contract time extension for that parcel.

3. DESIGN-BUILD TEAM GENERAL RESPONSIBILITIES

3.1. General Scope

- 3.1.1. The Design-Build Team will be responsible for the services described in Section 7.2 of this Scope of Work for the entire project. The Design-Build Team will be responsible for performing all right of way acquisition services to the extent described in all the other following sections of this Scope of Work for any parcels for which the Department has (1) already reached settlement and the settlement will be affected by the Design-Build Team's design; (2) made an offer to settle and that offer will be affected by the Design-Build Team's design; (3) condemned and that condemnation will be affected by the

Design-Build Team's design; or (4) not identified that a parcel needs to be acquired based on the Right of Way Plans provided by the Department.

- 3.1.2. The Design-Build Team shall employ qualified, competent personnel who are currently approved by the NCDOT Right of Way Unit, hereinafter referred to as the Department, to provide all services necessary to perform all appraisal (except appraisal reviews and updated appraisals required solely for condemned parcels), negotiation and relocation services required for all right of way, control of access and easements including, but not limited to, permanent utility easements, necessary for completion of the project. For a list of currently approved firms, the Design-Build Team should contact Mr. Neal Strickland, in the NCDOT Right of Way Unit, at 919-707-4364.
- 3.1.3. All services shall be conducted in accordance with G.S. 136-28.1 of the General Statutes of North Carolina, as amended, and in accordance with the requirements set forth in the *Uniform Appraisal Standards and General Legal Principles for Highway Right of Way*, the *North Carolina Department of Transportation's Right of Way Manual*, the *North Carolina Department of Transportation's Rules and Regulations for the Use of Right of Way Consultants*, the *Code of Federal Regulations*, and Chapter 133 of the *General Statutes of North Carolina* from Section 133-5 through 133-18, hereby incorporated by reference, including the Uniform Relocation Assistance and Real Property Acquisition Policies Act of 1970, as amended.
- 3.1.4. Prior to performing any of the aforementioned work, a meeting shall be held between the Design-Build Team, the appraisers who will provide appraisal services for the Design-Build Team, the Attorney General's office, NCDOT Locations and Surveys Unit, the Right of Way Appraisal Review Section and NCTA.
- 3.1.5. The Design-Build Team shall field stake all right of way, control of access and easements including, but not limited to utility easements, in accordance with the requirements noted above.

3.2. Reports and Certifications

- 3.2.1. The Design-Build Team shall perform the services as set forth herein and furnish and deliver to the Department reports accompanied by all documents necessary for the settlement of claims and the recordation of deeds, or necessary for condemnation proceedings covering said properties.
- 3.2.2. The Design-Build Team shall submit a right of way project tracking report and right of way quality control plan to the Department. The Department standard forms and documents shall be used to the extent possible.
- 3.2.3. The Design-Build Team shall provide a current title certificate for each parcel as of the date of closing or the date of filing of condemnation, unless required otherwise in the NCDOT April 2015 *Right of Way Manual*. At the conclusion of the right of way acquisition process, the Design-Build Team shall provide a right of way certification to

the Division Right of Way Agent for rights of way and easements on parcels acquired by the Design Build Team.

- 3.2.4. The Design-Build Team shall prepare Right of Way Transmittal Summaries and/or Narrative Appraisals for all right of way, control of access and easement acquisitions. Claim Reports will not be allowed for any acquisition.
- 3.2.5. It is understood and agreed by and between the parties hereto that all reports, surveys, studies, specifications, memoranda, estimates, etc., secured by and for the Design-Build Team shall become and remain the sole property of the Department upon termination or completion of the work, and the Department shall have the right to use same for any public purpose without compensation to the Design-Build Team.

4. APPRAISALS

4.1. Appraisal Process

- 4.1.1. The Design-Build Team shall prepare appraisals in accordance with the Department's *Uniform Appraisal Standards and General Legal Principles for Highway Right of Way Acquisitions*. The Design-Build Team's appraiser shall be on the Department's approved state certified appraiser list. The Design-Build Team may request its state certified appraiser(s) be added to the approved state certified appraiser list, subject to approval by the Department's Area Appraiser and State Appraiser.
- 4.1.2. The NCDOT, or its agent, will provide appraisal reviews complying with the Department's *Uniform Appraisal Standards and General Legal Principles for Highway Right of Way Acquisitions*. The reviewer will ensure that the appraisal meets the Department's guidelines and requirements, conforms to acceptable appraisal standards and techniques, does not include any non-compensable items or exclude any compensable items and that the value conclusions are reasonable and based on facts presented in the appraisal. The reviewer has the authority to approve, adjust, request additional data or corrections, or not to recommend and request another appraisal. Within fifteen business days from the date of receipt, all appraisals, second appraisals, and/or appraisal corrections will be reviewed by NCDOT Review Appraisers or Review Appraisers under contract to the corresponding NCDOT Area Appraisal Office.
- 4.1.3. The NCDOT will sign as approving any and all appraisals to be used in acquisitions.

4.2. Second Appraisals

- 4.2.1. The Department will develop or contract with a private firm to develop and provide a second appraisal for parcels as noted below:
 - All parcels with an initial appraisal, with just compensation, equal to or greater than one million dollars (\$1,000,000.00).

- All parcels where the initial appraisal indicates damages to the remaining property equal to or greater than two hundred fifty thousand dollars (\$250,000.00), where damages to the remaining property are defined as a loss in value to the remaining land, and/or improvements and/or a cost to cure.
- The Department expects second appraisals, including review, to take approximately 75 – 90 calendar days from completion of the initial appraisal review or notification from the Design-Build Team of the need for a second appraisal. Therefore, the Design-Build Team is encouraged to provide advance notification to the Department with a list of parcels that are anticipated to meet the requirements of this Section 4.2.1.

5. COST RESPONSIBILITY

5.1. Cost of Acquisition Services

The Design-Build Team shall be responsible for all costs, payments, and fees associated with the acquisition services for right of way, easements, and control of access, including attorney fees required for all non-condemnation acquisitions for those situations outlined in Section 3.1.1 of this *Right of Way Scope of Work*.

5.2. Payments to Property Owners

- 5.2.1. With respect to the payments, costs and fees associated with the acquisition of right of way, easements and/or control of access, the Department will be responsible for direct payments to property owners for (1) negotiated settlements; (2) recording fees; (3) any relocation benefits; and (4) deposits and fees involved in the filing of condemnation claims. The Department will assume responsibility for all costs associated with the litigation of condemned claims, including testimony by the appraiser(s).
- 5.2.2. For all property purchased in conjunction with the project, title shall be acquired in fee simple or easement and shall be conveyed to “The North Carolina Department of Transportation”, free and clear of all liens and encumbrances except permitted encumbrances.

5.3. Insurable Structures

Acquisition services required outside of the project construction limits due solely to a rise in the floodplain water elevation on insurable structures will be considered extra work and paid for in accordance with Article 104-7 of the 2018 NCDOT *Standard Specifications for Roads and Structures*.

5.4. Technical Assistance

A Department representative will be available to provide technical guidance on right of way acquisition procedures and to make timely decisions on approving relocation benefits and approving administrative adjustment settlements on behalf of the Department over and above the authority granted to the Department Right of Way Consultant Project Managers.

6. CONDEMNATION

6.1. Condemnation Maps

The Department will prepare all Condemnation Maps.

6.2. Condemnation Reports

- 6.2.1. The Design-Build Team shall prepare all Final Condemnation Reports. Upon approval of the Final Condemnation Report, the Department will require a minimum of eight weeks to file the condemnation claim.
- 6.2.2. For all plan revisions on condemned parcels that modify the area acquired, modify the control of access and/or impact the appraised value, the Design-Build Team shall be responsible for the following:
 - The Design-Build Team shall notify the Division Right of Way Agent, the Area Negotiator, Area Appraiser, and the Attorney General, in writing, that revisions have been made that impact a condemned parcel, and provide updated plan sheets and revised area takes.
 - The Design-Build Team shall consult with the Attorney General and the Area Appraiser to determine the status of the negotiations and appraisal(s).
 - If the Attorney General and/or Area Appraiser recommend an updated appraisal, the Design-Build Team shall provide an updated Summary Sheet to the Area Appraiser for the Department's use in obtaining an updated appraisal(s).
 - Upon receipt of the approved updated appraisal(s), the Design-Build Team shall develop a revised written offer. If settlement is not reached, the Design-Build Team shall submit an updated Final Condemnation Report. If settlement is reached, the Design-Build Team shall notify the Attorney General and Area Appraiser in writing and submit an updated Final Condemnation Report with all necessary documentation.
 - The Department will be responsible for payment for the additional deposit to the Attorney General's Office and the Attorney General will prepare and file an Amendment to the Declaration of Taking.

7. RECORDATION

7.1. Register of Deeds

- 7.1.1. The Design-Build Team shall prepare, execute and record documents conveying title to acquired properties to the Department with the Register of Deeds.
- 7.1.2. The Design-Build Team shall deliver all executed and recorded deeds and easements to the Department.

7.2. Plans for Recordation

The Design-Build Team shall adhere to the Location and Survey Unit's September 28, 2018 Proc 2018-3 – Creating NCDOT Right of Way Plan Sheets for LET Projects and Proc 2018-5 – Elimination of Need to Request Control Sheets and Property Ties and RW Series Development Timeline Memorandums (references to timelines in the aforementioned Memos shall be disregarded).

- 7.2.1. The Design Build Team shall develop and provide Right of Way series of plan sheets (“R/W” series of plan sheets) that delineate the existing property information, property ties, proposed centerline data, existing and proposed right of way, existing and proposed easements, and existing and proposed control of access. The “R/W” series plan sheets shall be signed and sealed by a Professional Land Surveyor registered in the State of North Carolina. The Professional Land Surveyor’s signature and seal shall attest that the right of way monuments were placed under their responsible charge.
- 7.2.2. The Design Build Team shall develop and provide a table of control points for the proposed centerline alignments (“D” series of plan sheets).
- 7.2.3. The Design Build Team shall develop and provide a table of proposed right of way and permanent easement control points (“E” series of plan sheets) that shall be signed and sealed by a Professional Land Surveyor registered in the State of North Carolina.

8. MISCELLANEOUS REQUIREMENTS

8.1. Descriptions and Revisions

- 8.1.1. Unless otherwise approved by the NCDOT Assistant State Negotiator, in writing, the Design-Build Team shall provide right of way, control of access and easement descriptions in metes and bounds format (bearings and distances). The Design-Build Team shall provide exhibits, diagrams and/or other information required to verify the aforementioned descriptions.
- 8.1.2. In accordance with the NCDOT April 2015 *Right of Way Manual*, the Design-Build Team may prepare red-line adjustments for parcels that are not condemned. The Department must approve a red-line adjustment, in writing, prior to the Design-Build Team making an offer based on the red-line adjustment.

8.2. Relocations

- 8.2.1. The NCDOT will provide relocation reviews and approvals for all Replacement Housing Payment calculations and all Rent Supplement Payment calculations prior to the Design-Build Team making any offers to the displacees. Within five business days of the receipt of the Replacement Housing Payment or Rent Supplement Payment calculation documentation, which shall include all documentation required for an Evaluation Package, the Department will approve the calculation, and the signed FRM15-D will be returned to the Design-Build Team, or a request for an updated calculation or

documentation will be presented to the Design-Build Team for further handling. At this time, the Relocation Coordinator in the NCDOT Right of Way Unit is the approving authority for the aforementioned calculations.

- 8.2.2. All Claims for Payment involving relocation benefits must be submitted to the NCDOT Relocation Coordinator in the Right of Way Unit for approval and processing.

8.3. Septic Systems

The Design-Build Team shall coordinate with the Health Department to determine if septic systems can be relocated/modified to remain operational. To assist with the aforementioned determinations, the Design-Build Team may utilize a third-party consultant to perform the septic system inspections only if the Health Department approves the third-party consultant, in writing, prior to the inspections beginning. The Department will only be responsible for the Health Department fees and/or third-party fees associated with these determinations. The Design-Build Team shall determine the relocation/modification design and construction costs required for the septic systems to remain operational and include these costs in the property right of way appraisals. (Reference the Utilities Coordination Scope of Work found elsewhere in this RFP)

9. TRANSPORTATION CORRIDOR MAP ACT

9.1. Initial Assessment

- 9.1.1. Regarding the Transportation Corridor Map Act ruling (Map Act), the Design-Build Team shall analyze the 1997 Corridor Protection Map for the project and provide the following:
- Identify which properties are currently owned by the same individuals or their heirs as denoted on the corridor protection maps.
 - Submit a list of parcels and owners affected by the Transportation Corridor Map Act to the Department so that future mapping may be developed by the Department.
 - Obtain 30-year title opinions for those properties affected by the Transportation Corridor Map Act.

9.2. Map Act Offers

- 9.2.1. In accordance with the requirements herein, for all parcels that 1) consist of property that was in the corridor per the corridor protection map, 2) are owned by the same individuals, or their heirs, that owned the parcel at the time the corridor protection map was filed, and 3) require property acquisition for construction of the project, the Design-Build Team shall attempt to settle the claim in a manner that would also settle any potential Map Act inverse claim using a settlement agreement (provided by the Department) along with the standard right of way deeds.

- 9.2.2. If the property does have an active Map Act inverse claim, the Design-Build Team shall attempt to settle the acquisition claim concurrent with the Map Act inverse claim, utilizing a settlement agreement and Map Act dismissal documents that will be provided by the Department.
- 9.2.3. Assistant State Negotiator Tracy Clark will be the point of contact for administrative adjustments used to settlement Map Act inverse claims on properties with either no Map Act inverse claim or with an active Map Act inverse claim.
- 9.2.4. The Department prefers that the Design-Build Team attempt to settle the acquisition necessary for constructing the project and the Map Act concurrently. However, if the acquisition necessary for constructing the project is critical to the Design-Build Team's schedule, the Design-Build Team will not be required to negotiate both of the aforementioned claims at the same time.
- 9.2.5. The NCDOT, or its agent, will provide all the Map Act appraisals. The Design-Build Team shall send all Map Act appraisal requests to Mr. Michael Albertson, Acting Area Appraiser, in the NCDOT Area 3 Appraisal Office located at 1605 Westbrook Plaza Drive, Suite 202 in Winston-Salem North Carolina. The Design-Build Team shall include the aforementioned 30-year title opinion with the corresponding Map Act appraisal request. The Design-Build Team should expect it to take a minimum of three months for the Department to provide an approved Map Act appraisal.
- 9.2.6. If unsuccessful in settling the claim in a manner that would also settle any potential Map Act claim, the Design-Build Team shall notify the Department in writing. At that time, the Department will be responsible for all other services required to settle the Map Act claims, except processing the formal paperwork required for documenting and recording final settlements.

UTILITIES COORDINATION SCOPE OF WORK~~(12-14-18)~~1-10-19)**1. GENERAL****1.1. Department Utility Relocation Coordination**

- 1.1.1. The Department has initiated the utility relocation coordination efforts on this project. The Department will continue to handle the utility relocation efforts throughout the procurement process.
- 1.1.2. During the procurement process, a representative from each prospective Design-Build Team is invited to participate in Department-led utility coordination meetings if requested in writing to the NCTA Chief Engineer. In such case, the Design-Build Team may identify one or two individuals to represent the Design-Build Team in such meetings. The Department and NCTA make no representation that Design-Build Team members will be invited to all meetings. In addition, these meetings are not intended to address Design-Build Team questions but rather allow the Design-Build Team utility coordinators to participate first hand in the relocation discussions during procurement.
- 1.1.3. Upon execution of the Contract, the Design-Build Team utility coordinator(s) will be required to attend all Department-led utility coordination meetings.
- 1.1.4. The Department will further the utility coordination efforts until 60 calendar days after the contract is executed. At such time, the Design-Build Team utility coordinator(s) will assume full responsibility for the remainder of all utility relocation coordination efforts and cost responsibilities as further as outlined in the remainder of this scope.
- 1.1.5. The Department will not be responsible for any utility coordination efforts attributable to the Design-Build Team's modification of the Roadway Plans provided by the Department, either within or after the aforementioned 60 days following Contract execution.
- 1.1.6. During procurement, the Department will attempt to provide utility coordination progress status reports approximately once per month.

1.2. General Scope

- 1.2.1. The Design-Build Team shall obtain the services of a Professional Services Firm (PSF) knowledgeable in the NCDOT Utility Coordination Process involved with utility relocation/installation and highway construction. The PSF shall be responsible for coordinating all utility relocations, removals and/or adjustments where the Design-Build Team and utility owner, with concurrence from the NCTA, determine that such work is essential for highway safety and performance of the required highway construction. Coordination shall be for all utilities whether or not they are specifically identified in this Scope of Work and shall include any necessary utility agreements when applicable. NCDOT will be the approving authority for all utility agreements and approval of plans.

- 1.2.2. In accordance with the requirements herein, the Design-Build Team shall relocate/coordinate the relocation of all existing facilities that are 1) parallel to a roadway in full control of access, 2) in physical conflict with the construction, 3) beneath the existing or proposed pavement structure and structurally inadequate, and/or 4) beneath the existing or proposed pavement structure and consist of unacceptable material. Proposed / relocated underground facilities that are located beneath the pavement structure shall only be allowed to cross the roadway as close to perpendicular as practicable.
- 1.2.3. The Design-Build Team will only be allowed direct contact with the utility owners when the PSF is present.

2. PROJECT DETAILS AND KNOWN UTILITY OWNERS

2.1. Known Utility Owners

- 2.1.1. The Design-Build Team shall be responsible for verifying the utility locations, types of facilities, and identifying the utility owners in order to coordinate the relocation of any utilities, known (shown in Table 1) and unknown, in conflict with the project.
- 2.1.2. The NCTA has initiated relocation efforts for the locations where telecommunication, power distribution and transmission and gas facilities are in conflict with the project. Resolutions of the conflicts between the project and these facilities are based on the project Roadway Right of Way Plans. The NCTA will update the Proposers with the most current information during the procurement process. The NCTA will continue this coordination, with the assistance of the Design-Build Team, until the conflicts have been resolved.

2.2. Water and Sewer

The NCTA has initiated the design efforts for the locations where water and sewer facilities are in conflict with the project. Resolutions of the conflicts between the project and these facilities are based on the project Roadway Right of Way Plans provided by the Department. The Utility Construction plans have been prepared and will be furnished to the Design-Build Teams. All costs associated with the water and sewer facilities construction shall be the responsibility of the Design-Build Team and shall be included in the lump sum bid for the project. The Design-Build Team will be responsible for any water and sewer re-design efforts required as a result of the Design-Build Team's final design, including the costs associated with the utility owner's review of the revised water and sewer plans.

The relocation and / or encasement of all water and sewer facilities shall be done in accordance with the NCDOT policies and standards, as well as the latest utility owners water and sewer design requirements / specifications. In the event of conflicting design parameters in the requirements noted above, the proposed design shall adhere to the most conservative values. The materials and appurtenances proposed by the Design-Build Team shall require approval by both NCDOT and the aforementioned appropriate utility owner prior to installation.

Table 1

Utility Owner	Utility Type	Cost Responsibility (if known)
AT&T	Telecommunications	AT&T
Aqua	Water & Sewer	Design-Build Team
Town of Cary Water and Sewer	Water & Sewer	Design-Build Team
CenturyLink	Telecommunications	CenturyLink
Colonial Pipeline	Gas	NCDOT
Conterra Ultra Broadband	Telecommunications	Conterra
Duke Energy	Power Distribution	NCDOT
Duke Energy	Power Transmission	NCDOT
Level 3	Telecommunications	Level 3
MCNC	Telecommunications	MCNC
PSNC	Gas	PSNC
Spectrum/CenturyLink	Telecommunications	Spectrum
Sprint	Telecommunications	Sprint
Town of Fuquay-Varina Public Utilities	Water & Sewer	Design-Build Team
Windstream Communications	Telecommunications	Windstream

3. UTILITY RELOCATION PLANS

3.1. Plans

Excluding water and sewer conflicts, if the Design-Build Team's design and/or construction create a new or modified utility conflict, the Design-Build Team shall request that the utility owner submit relocation plans (Highway Construction Plans to be provided by the Design-Build Team to utility owners) that show existing utilities and proposed utility relocations for approval by the NCDOT.

3.2. Submittal Process

In .pdf format, the Design-Build Team shall electronically submit one half-size set and one full size set of the Utility Relocation Plans to the NCDOT State Utilities Manager, via NCTA, for review and approval. The Department shall approve the Utility Relocation Plans prior to any utility relocation work beginning. The Design-Build Team shall also be responsible for submitting the

appropriate agreements to be used with the Utility Relocation Plans (See Agreements Section found elsewhere in this Scope of Work). After the review process is complete, the NCDOT Utilities Unit will submit an electronic copy of the authorization letter to the Design-Build Team. The NCDOT Utilities Unit will also submit an electronic copy of the approved Utility Relocation Plans, estimate and agreement to the Department's Resident Engineer. If the Utility Relocation Plans are approved, subject to changes, it shall be the Design-Build Team's responsibility to coordinate these changes with the appropriate utility owner.

4. COST RESPONSIBILITY

4.1. General Cost Responsibility

- 4.1.1. The Design-Build Team shall be responsible for all costs associated with relocating and/or encasing water and sewer facilities, as described in Section 2.2 of this Scope of Work.
- 4.1.2. Colonial Pipeline will hire inspectors for certain activities performed by the Design-Build Team within their right of way or easement, such as excavation. The Department will pay for these inspection costs directly to the owners. However, the Design-Build Team shall include **Twenty-Five Thousand Dollars** (\$25,000.00) in their Price Proposal to reimburse the Department for the actual cost of the inspections up to the maximum of \$25,000.00.
- 4.1.3. The NCDOT will be responsible for all other non-betterment utility relocation costs when the utility owner has prior rights of way/compensable interest. The utility owner shall be responsible for the relocation costs if they cannot furnish evidence of prior rights of way or a compensable interest in their facilities. The Design-Build Team shall be responsible for verifying/determining the cost responsibility (prior rights and compensable interest) for the utility relocations. The Design-Build Team shall be responsible for all costs associated with utility relocations due to haul roads and/or any other temporary conditions resulting from the Design-Build Team's methods of operation or sequence of work.
- 4.1.4. The Design-Build Team shall also be responsible for all costs associated with relocating or adjusting utilities, [due to the Design-Build Team's construction methods or their design change](#), that have already been relocated once, or have been authorized to be relocated, to accommodate the design shown on the Right of Way Plans provided by the NCTA.

4.2. Compensable Interest

- 4.2.1. Typically, affidavits, recorded easements or NCDOT agreements can serve as evidence of prior rights. A compensable interest is identified as follows:
 - (A) Existing or prior easement rights within the limits of the project, either by recorded right of way or adverse possession (Utility occupying the same location for twenty (20) plus years outside the existing highway rights of way).
 - (B) Entities covered under *General Statute 136-27.1* and *136-27.2*. Statute requires the NCDOT to pay the non-betterment cost for certain water, sewer and gas relocations.

- (C) Utilities that have a joint-use agreement that constitutes a compensable interest with entities that have existing or prior easements rights.

4.3. Work Performed by Design-Build Team for Utility Owners

- 4.3.1. If the Design-Build Team elects to make arrangements with a utility owner for proposed utility construction not required herein, in which the utility owner shall be responsible for the costs of work to be performed by the Design-Build Team, the Design-Build Team shall be responsible for negotiating all costs associated with the proposed construction. Once the Design-Build Team and the utility owner agree on a plan and a lump sum estimated cost for the utility construction, the Design-Build Team shall electronically submit one half-size set and one full size set of the utility construction drawings, in .pdf format, to the State Utilities Manager, via NCTA, for further handling. Each set shall include a title sheet, plan sheets, profiles and special provisions, if required. Also, a letter from the utility owner agreeing to the plans and lump sum cost must accompany this package. The NCDOT will reimburse the Design-Build Team the estimated lump sum cost under a Supplemental Agreement. The necessary Utility Construction Agreement (UCA) to the utility owner for reimbursement shall be a two party agreement between the NCDOT and the utility owner; and will be developed and executed by the Department.
- 4.3.2. If the Design-Build Team is requested, in writing, by a utility owner to relocate facilities not impacted by the project's construction, and/or upgrade or incorporate new facilities as part of the highway construction, designs shall be coordinated with the utility owner and NCDOT Utilities Unit. The associated design and construction costs shall be negotiated and agreed upon between the Design-Build Team and the utility owner. The Design-Build Team shall develop these designs; prepare all plans for needed agreements and permits; submit permits directly to the agencies and obtain approval from the agencies. The Design-Build Team shall be responsible for all permit fees.

4.4. Communication Cables/Electrical Services for ITS

- 4.4.1. Prior to establishing the location for new meter poles, the Design-Build Team shall coordinate with the local power distribution company concerning accessibility of E/C service and safety in maintenance of the meter.
- 4.4.2. Prior to installation, the Design-Build Team shall provide plans for review and approval for all service taps that require a parallel installation within the control of access (C/A).
- 4.4.3. Parallel service installation within a C/A shall be buried and located as close to the right of way line as practical. Only due to unusual circumstances will parallel aerial service installations within the C/A be allowed. The Design-Build Team shall justify the allowance of parallel aerial service installation and obtain NCDOT approval prior to installation.
- 4.4.4. The Design-Build Team shall be responsible for all coordination activities, including deposit fees, required for the utility company to provide service taps. Prior to the Design-Build Team developing the associated design and/or instructing the utility company to

proceed with providing the service taps, the Design-Build Team shall obtain written approval of the service tap locations from the NCDOT.

- 4.4.5. The NCDOT will be responsible for construction costs associated with the utility company providing service taps. The Design-Build Team shall be responsible for all costs associated with providing communication cables/electrical service from the service tap to the ITS devices.

4.5. Adjusting Existing Utilities due to Proposed Traffic Management Systems Fiber Optic Communications Cables

The Design-Build Team shall be responsible for all costs for coordinating and adjusting any utilities that are in conflict with any proposed communication cables. The NCDOT shall approve adjustments and relocations of existing facilities prior to the Design-Build Team developing the associated designs.

5. BRIDGE ATTACHMENTS AND COORDINATION DURING CONSTRUCTION

5.1. Bridge Attachments Prohibited

- 5.1.1. Unless otherwise directed in this RFP, the Design-Build Team shall avoid utility attachments to structures. Attachments shall only be considered when other alternatives are cost prohibitive and/or are not feasible due to environmental or geographical features. All utility related attachments must be evaluated and approved by the State Utilities Manager, including any existing attachments to any structure(s) that require modification or replacement. Attachments shall be prohibited under the following conditions:

- No attachments shall be allowed to a bridge located parallel within the C/A carrying the freeway over streams, other roadways or railroads. (No parallel utility installations within the C/A)
- No attachments shall be allowed to cored-slab bridges.
- No attachments shall be allowed to curved bridges.

- 5.1.2. Attachments to structures, if approved by the State Utilities Manager, shall meet the following criteria:

- No attachments shall be allowed below the bottom of the beams and/or girders.
- Drilling of, or attachments to, beams and/or girders shall not be allowed. Attachments shall only be allowed to the bottom of the bridge deck.
- For water and sewer force mains, only restrained joint ductile iron pipe shall be allowed.
- A minimum of 18" of clearance to beams and/or girders shall be maintained if possible.

- 5.1.3. Documentation of adverse conditions or cost estimates of all feasible alternatives shall be submitted to the NCDOT State Utilities Manager, via NCTA, when seeking approval of a structure attachment. Cost estimates shall consider all costs involved with each alternative and impacts to the utility and the highway project as a whole.

5.2. Utility Coordination with Construction Activities

- 5.2.1. The Design-Build Team shall not commence work at points where the highway construction operations are adjacent to utility facilities, until arrangements are made with the utility owner to protect against damage that might result in expense, loss, disruption of service or other undue inconvenience to the public or utility owner. The Design-Build Team shall be responsible for damage to the existing or relocated utilities resulting from the Design-Build Team's operations. In the event of interruption of any utilities by the project construction, the Design-Build Team shall promptly notify the utility owner and cooperate with the utility owner in the prompt restoration of service.
- 5.2.2. The Design-Build Team shall accommodate utility adjustments, reconstruction, new installation that is associated with the project and routine maintenance work that may be underway or take place during the progress of the contract.
- 5.2.3. The Design-Build Team shall coordinate with the municipalities and the power companies to ensure that existing streetlights are maintained during construction to the greatest extent practicable and are replaced, as necessary, as part of the project. The Design-Build Team will be responsible for all costs associated with the replacement of any existing street lighting impacted by the project.
- 5.2.4. For the proposed Duke Energy crossing immediately west of River Falls Drive, Duke Energy will be installing a duct bank to assist with the conflicts with the proposed noise walls. This immediate area and suitable access will need to be rough graded and the NCTA and Duke Energy notified that this grading work is complete a minimum of 90 days prior to Duke Energy beginning construction of their duct bank. The duct bank, anticipated to be 6 feet in width, shall not be disturbed by the Design-Build Team and there shall be a minimum of a 3-foot offset from either side of the duct bank when locating and installing piles for the noise walls.

6. AGREEMENTS

6.1. Utility Analysis and Routing Report

The Design-Build Team shall develop a preliminary Utility Analysis and Routing Report (UARR (p)) to identify potential utility conflicts, determine preliminary alignments and schedules for the relocation of each utility, and identify any anticipated Permanent Utility Easements (PUE). The aforementioned UARR (p) shall be submitted to the NCDOT Utility Unit via NCTA, for review a minimum of ten days before the Right of Way Plans submittal.

6.2. Utility Relocation Agreements (URA) and Agreements Process

- 6.2.1. If a utility company can provide evidence of prior rights of way or a compensable interest in their facilities, the Design-Build Team shall coordinate the non-betterment utility relocation costs with the utility company and develop the Utility Relocation Agreement.
- 6.2.2. The NCDOT State Utilities Manager must execute approved agreements on Design-Build projects. The URA's and Encroachment Agreements are available from the NCDOT Utilities Unit connect site. Use this site for the most current agreements and forms. Reference the NCDOT Utility Manual Policies & Procedures for Accommodating Utilities on Highway Rights of Way for the different types of Encroachment Agreements available for use.
- 6.2.3. The Design-Build Team shall submit all utility agreements, and all supporting documents to the NCDOT State Utilities Manager, via NCTA, in electronic format. Prior to submittal, all agreements shall be signed electronically by an authorized representative of the utility owner. These electronic agreement packets will be reviewed, approved and signed electronically by the NCDOT State Utilities Manager, or a designated representative, before being distributed to the field.
- 6.2.4. The Design-Build Team shall utilize the NCDOT Standard Utility Encroachment Agreements, as necessary, in relocating utilities. The Encroachment Agreements shall be used under the following conditions:
 - If a utility company is not occupying a valid right of way/compensable interest and the proposed relocation will place the relocated utilities within the existing or proposed highway right of way.
 - For all new utility installations, not covered under a Utility Construction Agreement and within the existing or proposed highway right of way. This includes all water, sewer and gas lines owned by entities covered under General Statute 136-27.1 and 136-27.2.

7. PRINCIPLE STANDARDS

The Design-Build Team shall be required to use the guidelines as set forth in the following:

- *NCDOT Utility Manual - Policies & Procedures for Accommodating Utilities on Highway Rights of Way* and the *NCDOT Utilities Policy Manual*. If the two aforementioned manuals contradict each other, the *Utilities Policy Manual* shall govern. Reference the website noted below for the current version of the NCDOT utility manuals, and additional information on the transition to the new utility manuals that shall be adhered to:

<https://connect.ncdot.gov/municipalities/Utilities/Pages/UtilitiesManuals.aspx>

- *Federal Aid Policy Guide* - Subchapter G, Part 645, Subparts A & B

- *Federal Highway Administration's Program Guide, Utility Adjustments & Accommodations on Federal Aid Highway Projects*
- *NC DOT Construction Manual* Section 105-8
- *NC DOT Right of Way Manual* - Chapter 16 Utility Relocations
- *NCDEQ Public Water Supply* - Rules governing public water supply
- *NCDEQ Division of Water Resources* - Title 15A - Environment and Natural Resources

EROSION AND SEDIMENT CONTROL SCOPE OF WORK

(11-7-18)

1. GENERAL AUTHORITY

The NCTA is operating under the NCDOT's delegated authority with the North Carolina Sedimentation Control Commission. Under this arrangement, the NCDOT Roadside Environmental Unit (REU) has the authority to (1) identify special needs for this project, including the acquisition of additional right-of-way; (2) mandate special details to be included in the design plans or special provisions; (3) conduct on site plan reviews for compliance and require design changes to accommodate field changes; (4) inspect all construction sites including waste and borrow pits and haul roads; and (5) issue violation notifications or cease and desist orders. The NCDOT REU will also retain authority in plan, detail, and special provision review and acceptance.

The NCTA and NCDOT REU shall review and accept all Erosion and Sedimentation Control Plans. Clearing & Grubbing and Final Grade Release for Construction (RFC) Erosion Control Plans shall be submitted to all NCTA and NCDOT Personnel listed in the Design-Build Submittal Guidelines before **any** land disturbing activities, including clearing and grubbing, can commence. If the Design-Build Team chooses to perform the work in discrete sections, then a complete set of Clearing & Grubbing and Final Grade RFC Erosion Control Plans shall be submitted, accepted, and distributed, as noted above, prior to land disturbing activities, including clearing and grubbing, commencing in that section. No land disturbing activities, including clearing and grubbing, shall occur in any location that does not have accepted Clearing & Grubbing and Final Grade RFC Erosion Control Plans. Refer to the most recent versions of the NCDOT *Erosion and Sediment Control Design and Construction Manual* and the NCDEQ - *Erosion and Sediment Control Planning and Design Manual* for erosion control design guidelines not addressed in this Scope of Work.

2. EROSION AND SEDIMENTATION CONTROL DESIGN**2.1. Design Process and Requirements****2.1.1. Pre-Submittal Meeting**

- A pre-submittal meeting shall take place between the NCDOT Roadside Environmental Unit Soil & Water Engineering Section, the Design-Build Team, NCTA, and any other pertinent NCDOT personnel before any Erosion and Sedimentation Control Designs are submitted to NCDOT Roadside Environmental Unit. Erosion and Sedimentation Control Plan submittals shall only be reviewed and accepted by NCDOT Roadside Environmental Unit after the Erosion and Sedimentation Control Pre-Submittal Meeting. The Design-Build Team shall be required to submit a tentative Erosion and Sedimentation Control Plan submittal schedule at the pre-submittal meeting.
- At a minimum, the Design-Build Team shall bring one erosion control plan sheet with a Clearing & Grubbing erosion control design to the Erosion and Sedimentation Control Pre-Submittal Meeting.

2.1.2. Design and Plan Submittals

- All erosion and sediment control design shall be in accordance with North Carolina *Design Standards in Sensitive Watersheds* throughout the project limits.

- All jurisdictional streams within the project limits shall be identified as “Environmentally Sensitive Areas” on the Sediment and Erosion Control Plan.
- NCDOT and NCTA strongly discourage the Design-Build Team from selecting borrow/waste site locations, staging areas, equipment storage areas, and refueling areas within 0.25 mile of Swift Creek.
- Plan submittals shall include all pertinent design information required for review, such as design calculations, drainage areas, etc.
- Plans shall address any environmental issues raised during the permitting process.
- The NCDOT Roadside Environmental Unit will provide a sample set of Erosion and Sedimentation Control Plans (including any special details or special provisions used by the NCDOT Roadside Environmental Unit) and MicroStation Erosion Control Workspace to the Design-Build Team for reference upon request.
- Temporary access and haul roads, other than public roads, constructed or used in connection with the project shall be considered a part of the project and addressed in the Erosion and Sedimentation Control Plans. Temporary access and haul roads located within the footprint and / or the right of way / easement corridor of the project shall be part of the highway Erosion and Sedimentation Control Plans.
- The Design-Build Team shall allow sufficient time in the proposed schedule to address any comments to the Erosion and Sedimentation Control Plans, as deemed necessary by the NCDOT Roadside Environmental Unit.
- Any Erosion Control Design revision made during the construction of the project shall be submitted to NCDOT Roadside Environmental Unit and NCTA by the 15th of the month. At any time requested by the Engineer or the NCDOT Roadside Environmental Unit, the Design-Build Team shall provide an updated version of the Erosion and Sedimentation Control Plans for distribution to all parties involved in the construction process.
- Once RFC Erosion and Sedimentation Control Plans are issued, any major design change or addition, any change that involves calculations, and any addition, deletion, or relocation of a sediment basin shall be submitted to the NCDOT Roadside Environmental Unit and NCTA for review and acceptance. Minor changes such as moving silt fence, adding or moving temporary ditches (unless adding new runoff flow to a sediment basin), and adding or moving slope drains shall be reviewed by the Engineer in the field.
- The Design-Build Team’s erosion and sedimentation control designer shall submit design calculations, for the Department’s review and acceptance, for all modifications to the Erosion and Sedimentation Control Plans that result in dimension modifications and / or relocations, other than minor shifts to accurately place, to the devices noted below:
 - Riser Basin
 - Skimmer Basin and all devices with Skimmers
 - Temporary Rock Sediment Dam Type A

- Temporary Rock Sediment Dam Type B
 - Temporary Rock Silt Check Type A
 - Culvert Construction Sequences
 - Temporary and Permanent Stream Channel Relocations
- All RFC Erosion and Sedimentation Control Plans, including any red line revisions, shall be kept on site at all times throughout the duration of the project.

2.1.3. Water Quality Stormwater Measures

Stormwater controls, both temporary and permanent, intended to serve water quality purposes will be highlighted on all phases of the erosion control and right of way plans in such a way to denote specific attention. Water quality stormwater controls include the level spreader, preformed scour hole, detention basin, swale, forebay, hazardous spill basin, bridge stormwater controls filtration basin, stormwater wetland, filter strip and buffer as well as any other measures included in the most current version of the NCDOT Stormwater Best Management Practices Toolbox or deemed appropriate by the Design-Build Team. Construction and maintenance of water quality stormwater controls is to be completed as specified in the plans so as not to alter the purpose of the design. Any field modifications of these stormwater measures require prior approval by the Engineer.

2.2. Clearing and Grubbing Phase Plans

2.2.1. Use correct NCDOT symbology.

2.2.2. Protect existing drainage structure inlets with Rock Inlet Sediment Trap Type 'A' (RIST-A), Rock Inlet Sediment Trap Type 'C' (RIST-C), Rock Pipe Inlet Sediment Trap Type 'A' (PIST-A), etc.

2.2.3. Utilize adequate perimeter controls (temporary silt ditches (TSD), temporary silt fence (TSF), etc.).

2.2.4. Clean Water Diversions (CWD) shall not be used to divert offsite runoff through the project construction limits.

2.2.5. Utilize skimmer basins and rock measures with sediment control stone (Temporary Rock Sediment Dam Type 'B' (TRSD-B), Temporary Rock Silt Check Type 'A' (TRSC-A), etc.) at drainage outlets.

2.2.6. Account for topography and show existing contour lines on Clearing & Grubbing Plans only.

2.2.7. Utilize Temporary Rock Silt Checks Type 'B' (TRSC-B) or wattles to reduce velocity in existing ditches with spacing of 250 feet divided by percentage of ditch grade. Also utilize TRSC-B's in proposed TSD's and temporary diversions (TD).

2.2.8. Protect existing streams; do not place erosion control devices in live streams unless permitted by the Division of Water Resources 401 Certification and the Army Corps of Engineers 404 Permit.

- 2.2.9. Sediment basins shall be sized to provide adequate silt storage for 3600 cubic feet per disturbed acre with surface area equal to 435 square feet per cubic foot per second (cfs) of the peak inflow rate, Q25, using 25-year peak rainfall data (NCDEQ - *Erosion and Sediment Control Planning and Design Manual* or NOAA's National Weather Service website <http://dipper.nws.noaa.gov/hdsc/pfds/> for partial duration (ARI) time series type). A Sediment Basin Designer Spreadsheet will be provided by the NCDOT Roadside Environmental Unit upon request.
- 2.2.10. Skimmer Basins shall be sized to provide adequate silt storage for 1800 cubic feet per disturbed acre with surface area equal to 325 square feet per cubic foot per second (cfs) of the peak inflow rate, Q25, using the 25-year peak rainfall data (NCDEQ - *Erosion and Sediment Control Planning and Design Manual* or NOAA's National Weather Service website <http://dipper.nws.noaa.gov/hdsc/pfds/> for partial duration (ARI) time series type). Skimmer Basins shall be designed to dewater in two to three days. A Skimmer Basin Designer Spreadsheet will be provided by the NCDOT Roadside Environmental Unit upon request.
- 2.2.11. Design Riser Basins to the following standards:
- Surface Area shall be determined by Equation A (sq. feet) = Q25 (cfs) * 435.
 - Volume requirement shall be 1800 cubic feet per disturbed acre draining to the riser basin.
 - Riser Pipe shall have a cross-sectional area 1.5 times that of the barrel pipe.
 - The riser pipe shall be non-perforated with a skimmer attached to the bottom of the pipe, one foot from the bottom of the basin.
 - See NCDEQ - *Erosion and Sediment Control Planning and Design Manual* for additional design criteria.
- 2.2.12. The minimum and maximum length to width ratio of all Sediment Basins shall be 2:1 and 6:1, respectively.
- 2.2.13. Coir Fiber Baffles shall be installed in all silt basins and sediment dams at drainage outlets. For silt basins with a 20-foot or longer length, three Coir Fiber Baffles shall be installed with a spacing of 1/4 the basin length. For silt basins with a length less than 20 feet, a minimum of two Coir Fiber Baffles shall be installed, with a spacing of 1/3 the basin length. The Design-Build Team will not be required to show the individual baffles on the Erosion Control Plans, but shall be required to incorporate the Coir Fiber Baffle Detail on the Erosion Control Plans.
- 2.2.14. Include any culvert and / or pipe construction sequence plan sheets in the Clearing & Grubbing Plans; all pipes 48 inches or larger, or any combination of pipes that total 48 inches or more carrying jurisdictional waters shall require a construction sequence. Prior to installation of pipes smaller than 48 inches in jurisdictional areas, the Design-Build Team shall submit a phasing plan for managing the watercourse to the Resident Engineer for review and acceptance. The phasing plan shall be in accordance with the NCDOT *Best Management Practices for Construction and Maintenance Activities*.

- 2.2.15. During construction, provide temporary sediment basins that dewater from the surface at all permanent stormwater devices.
- 2.2.16. Utilize Coir Fiber Wattles with Polyacrylamide (PAM) and / or TRSC-As with Matting and PAM in temporary and permanent, existing and proposed ditches at a spacing of 50 feet in areas where sediment basins are not feasible at drainage outlets and in areas where sediment basins at drainage outlets with sediment traps (i.e. PIST-A, RIST-A, etc.), cannot be properly sized to surface area and/or sediment storage requirements due to safety concerns, right of way restrictions, utility conflicts, or other construction limitations approved by the NCDOT Roadside Environmental Unit.
- 2.2.17. Place a device utilizing PAM at all sediment basin inlets.
- 2.2.18. At a maximum spacing of 200 feet, and as directed, utilize Special Sediment Control Fence drainage breaks in silt fence.
- 2.2.19. Do not place erosion control devices that require excavation (i.e. sediment basins, silt ditches, etc.) in wetlands.
- 2.2.20. Within the entire project limits, provide disturbed and undisturbed drainage areas in MicroStation Format.
- 2.2.21. For all drainage outlets where the runoff cannot be treated with a sediment basin and / or the sediment basin cannot be constructed to the required sediment storage or surface area requirements, provide a written explanation.
- 2.2.22. Excluding perimeter Sediment Basins that will function only during Clearing and Grubbing operations, all perimeter Sediment Basins shall be placed outside of fill slopes.

2.3. Final Grade Phase Plans

In addition to the requirements of Section 2.2, the Final Grade Phase Plans shall:

- 2.3.1. Utilize temporary slope drains and earth berms at top of fill slopes eight feet or higher and a fill slope steeper than 4:1, or where there are superelevations above 0.04 and fills are greater than five feet. Maximum slope drain spacing shall be 200 feet.
- 2.3.2. Utilize a rock energy dissipater at the outlet of all slope drains.
- 2.3.3. Devices at all drainage turnouts shall utilize skimmer or sediment control stone (TRSD-B, TRSC-A, etc.) and a spillway with an adequately designed base length to distribute outflow.
- 2.3.4. Provide matting for erosion control in all ditch lines, including but not limited to temporary ditch lines (TDs) utilized to divert offsite runoff around construction areas, where the velocity is greater than 2.0 feet / sec, and the shear stress is 1.55 psf or less. For ditch lines with a shear stress above 1.55 psf, Rip Rap shall be utilized.
- 2.3.5. Unless otherwise approved by the Roadside Environmental Field Operations Engineer, provide matting for erosion control on all slopes (cut and fill) that are steeper than 4:1 and a height of eight feet or greater.
- 2.3.6. Along all slopes (cut and fill) that are 30 feet or higher, place parallel rows of 12-inch Excelsior Wattles at a spacing height of 20 feet.

2.3.7. All perimeter Sediment Basins shall be placed outside of fill slopes.

2.4. Intermediate Phase

Intermediate Erosion Control Plans shall only be required if design modifications and / or site conditions require additional erosion control design or design revisions to the RFC Clearing and Grubbing and / or RFC Final Grade Erosion Control Plans. Intermediate Plans shall be submitted for review and shall be accepted prior to construction of any aspect impacted by the revised erosion control design. For any intermediate phase, comply with Section B, "Final Grade Phase" above.

3. DETAIL SHEETS, TITLE SHEETS AND SPECIAL PROVISIONS

3.1. Detail Sheets and Notes

- 3.1.1. Provide project specific special notes and details, including but not limited to, skimmer basin, coir fiber wattle with Polyacrylamide (PAM), etc.
- 3.1.2. Provide matting summary sheet(s): matting for erosion control, permanent soil reinforcement mat, and coir fiber mat.
- 3.1.3. Provide reforestation sheet(s): regular, wetland, streambank and / or buffer showing appropriate species.

3.2. Title Sheet

- 3.2.1. Show correct notes: NCG-01, HQW, ESA, clearing and grubbing, etc.
- 3.2.2. Show correct standards for project
- 3.2.3. List of standard NCDOT symbology
- 3.2.4. Show name and certification number of Level III certified individual responsible for designing and / or reviewing Erosion and Sedimentation Control Plans
- 3.2.5. Show name of primary NCDOT Roadside Environmental Unit Erosion and Sedimentation Control Plan reviewer

3.3. Special Provisions

- 3.3.1. Erosion Control Special Provisions are available at the following website:
<https://connect.ncdot.gov/resources/roadside/Pages/Soil-Water.aspx>
- 3.3.2. References in Erosion Control Special Provisions from the aforementioned website to Method of Measurement, Basis of Payment, or any other statement regarding direct payment for Erosion & Sediment Control measures shall be disregarded.
- 3.3.3. *Erosion & Sediment Control / Stormwater Certification* Project Special Provision found elsewhere in this RFP.

4. CONSTRUCTION REQUIREMENTS

4.1. General

- 4.1.1. The Design-Build Team shall comply with the North Carolina Administrative Code *Title 15A Environmental Quality* Chapter 4, Sedimentation Control.

- 4.1.2. An accepted Erosion and Sedimentation Control Plan shall not exempt the Design-Build Team from making every effort to contain sediment onsite.
- 4.1.3. Whenever the Engineer determines that significant erosion and sedimentation continues despite the installation of approved protective practices, the Design-Build Team shall be required to, and shall, take additional protective action.

4.2. Preliminary Construction Meeting

- 4.2.1. Prior to any land disturbing activity, the Engineer will schedule a meeting with Division construction personnel, Design-Build Team senior management, Design-Build Team project staff, NCTA, NCDOT project staff, consultant engineering / inspection staff, NCDOT Construction Unit, NCDOT Roadside Environmental Unit, Land Quality, Department of Water Resources and any other party associated with activities that impact the overall effectiveness of the project's erosion control.
- 4.2.2. During this meeting, the attendees shall review the Design-Build Team's Erosion Control Plans and identify potential erosion control issues. All attendees will provide comments, recommendations and supportive information to help facilitate resolution to the aforementioned potential erosion control issues.

4.3. Construction Meetings

- 4.3.1. Once construction begins, the NCTA will schedule monthly meetings to review the erosion control status. All parties listed above for the Preliminary Construction Meeting shall participate in these monthly construction meetings.
- 4.3.2. During the construction meetings, the erosion control efforts / issues to date will be reviewed and discussed. Additionally, the upcoming construction phases will be reviewed to identify potential erosion control issues. After the construction meeting, a project review may occur to identify site specific issues and identify solutions. The Design-Build Team shall be responsible for all actions, corrections and / or resolutions resulting from the construction meetings and / or subsequent site visits.
- 4.3.3. The NCDOT senior management will discuss issues that are repeatedly identified on inspection reports and / or discussed during the construction meetings with the Design-Build Team's senior management.
- 4.3.4. If project activities do not change the erosion control status / conditions, the Engineer may elect to change the construction meeting frequency or cancel a meeting.

4.4. Inspection and Certification

- 4.4.1. Erosion & Sediment Control / Stormwater Certification shall be required according to the Project Special Provision found elsewhere in this RFP.
- 4.4.2. Prior to installation of any erosion control devices, the Design-Build Team shall verify boundaries of jurisdictional areas in the field and delineate with Safety Fence or flagging. For guidance on Safety Fence and flagging in jurisdictional areas, see:

<https://connect.ncdot.gov/resources/roadside/Pages/Field-Operations-Documents.aspx>

4.4.3. Immediately after the clearing and grubbing erosion control measures have been installed for the entire project, or for individual sections if the Design-Build Team has divided the project into construction segments, the Design-Build Team's erosion and sedimentation control designer shall field verify constructed dimensions and installation of all erosion control devices. After this initial inspection(s), the designer shall review the project conditions a minimum of every 30 days during the heavy grading operations, and as directed by the Engineer, to verify the field conditions of disturbed areas draining to erosion control devices and to ensure that the erosion control devices provide the current field condition requirements for sediment storage and surface area. During construction, the NCDOT may conduct separate field inspections of the project conditions and the erosion control devices. The erosion and sedimentation control designer shall make appropriate design revisions to the Clearing and Grubbing, Intermediate Erosion Control Plans and / or Final Grade Erosion Control Plans resulting from / required by the Design-Build Team and / or the Departmental field inspections for the Department's review and acceptance, in accordance with the Design-Build Submittal Guidelines. The Design-Build Team shall concurrently provide written documentation of all field verifications / inspections performed by the Design-Build Team to the NCDOT Roadside Environmental Unit, Soil and Water Engineering and Field Operations Section, and the Resident Engineer. At a minimum, this documentation shall detail what was observed during the field verification / inspection and all resulting required actions with a timeframe for implementation. When the project conditions no longer warrant, in the sole discretion of the Department, inspections by the erosion and sedimentation control designer may cease.

4.5. Reclamation Plan

4.5.1. Borrow or waste areas that are part of the project shall require a separate Reclamation Plan, unless the borrow or waste activity is regulated under the *Mining Act of 1971*, or is a landfill regulated by the NCDEQ - Division of Waste Management (DWM). For newly created borrow pit(s) that require dewatering, Borrow Pit(s) Dewatering Basins shall be required and shall be in accordance with the applicable special provisions available at the website noted in Section IV above. The Design-Build Team shall submit the location and permit number for waste / borrow sites covered by the Mining Act or regulated by the NCDEQ - DWM concurrently to the Design-Build Unit and the Resident Engineer. For Reclamation Procedures, see:

<https://connect.ncdot.gov/resources/roadside/FieldOperationsDocuments/ContractedReclamationProcedures.pdf>

4.5.2. Temporary access and haul roads associated with borrow pits and staging areas shall be included in the Reclamation Plan.

4.6. Miscellaneous Construction Requirements

4.6.1. The Design Build Team shall carry out all erosion and sediment control related activities as contained in the Biological Assessment of Potential Impacts to Federally Listed Species (December 2017 and January 2018) and the Biological Opinion (April 2018).

4.6.2. At a minimum, the Design-Build Team shall install Floating Turbidity Curtain at ponds, lakes, and other jurisdictional standing water bodies 1) where construction activities

create surface fill impacts 2) or where sufficient erosion and sediment control devices cannot be installed to contain sediment and / or turbidity impacts.

- 4.6.3. To contain concrete waste water and associated concrete mix from washing out ready-mix trucks, drums, pumps, or other equipment, provide Concrete Washout Structures at egress points. Concrete Washout Structures must collect and retain all concrete waste water and solids so that this material does not migrate to surface waters or into the ground water. The Concrete Washout Structures are not intended for concrete waste not associated with washout operations. The Concrete Washout Structures may include devices above or below ground and / or commercially available devices designed specifically to capture concrete waste water. Concrete Washout Structure options may be found in the special provision, available at the website noted in Section IV above. For construction details of an above grade and below grade Concrete Washout Structure, reference the website noted below:

<https://connect.ncdot.gov/resources/roadside/SoilWaterDocuments/ConcreteWashoutStructure.pdf>

- 4.6.4. All erosion control measures with stone extending beyond the construction limits shall be considered temporary fill. If impacted wetland areas are permitted as Hand Clearing, then the aforementioned temporary fill shall be permitted as Temporary Fill in Hand Cleared Areas for Erosion Control. (Reference the Environmental Permits Scope of Work found elsewhere in this RFP).
- 4.6.5. Sediment basins that drain directly into jurisdictional water or have a total drainage area of one acre or more shall be designed and constructed with outlet structures that only withdraw water from the surface. For sediment basins that do not drain directly into jurisdictional water or have less than one acre of total drainage area, surface dewatering outlets or stone outlets may be provided.
- 4.6.6. In accordance with the requirements noted herein, the Design-Build Team shall be responsible for erosion control design, plans, plan implementation and maintenance of erosion control measures for all utility installation and relocation work performed by the Design-Build Team. To ensure that the Design-Build Team's erosion control designs, plan implementation and / or maintenance of erosion control measures do not conflict with the erosion control design, plan implementation and / or maintenance of erosion control measures for utility installation and / or relocation work performed by others, the Design-Build Team shall coordinate with the utility companies performing Utilities by Others (UBO) work.

5. VEGETATION MANAGEMENT AND GROUND COVER REQUIREMENTS

5.1. Vegetation Management

- 5.1.1. To ensure adherence with the August 1, 2016 NCG-010000 General Construction Permit, issued by the North Carolina Department of Environmental Quality, Division of Water Resources, the Design-Build Team shall formally submit a project-wide Vegetation Management Procedure for the NCTA and NCDOT's review and acceptance prior to any land disturbing activities. After this initial review, the Design-Build Team shall concurrently provide the NCTA and NCDOT Resident Engineer and Roadside Environmental Field Operations Engineer updated versions of the Vegetation Management

Procedure on a monthly basis. These updated versions will not require formal submittal to the NCTA, but will be subject to review comments by the aforementioned field personnel. All versions of the Vegetation Management Procedure shall include, but not be limited to, 1) provisions for the early establishment of grasses / vegetation, 2) provisions for obtaining the required 80% permanent vegetation stand, as defined in the August 1, 2016 NCG-01000 General Construction Permit and in accordance with the *Permanent Vegetation Establishment* Project Special Provision found elsewhere in this RFP, by the project final completion date, and 3) procedure and schedule details for fertilizer topdressing, supplemental seeding, mowing and repair seeding. The Vegetation Management Procedure shall be closely coordinated with the grading and hauling operations. The Design-Build Team shall provide a narrative overview of the Vegetation Management Procedure in the Technical Proposal.

- 5.1.2. From the beginning through the end of construction, the Design-Build Team shall maintain comprehensive “red-line” As-Constructed Drawings that detail when and where permanent / temporary / repair seeding and fertilizer topdressing have been performed.

5.2. Ground Cover Stabilization Requirements - NCG010000 (7 - 14 Days)

- 5.2.1. Ground cover stabilization shall comply with the timeframe guidelines specified by the North Carolina Department of Environmental Quality, Division of Water Resources NCG-010000 General Construction Permit that became effective on August 1, 2016. Excluding the slopes noted below, temporary and permanent ground cover stabilization shall be provided within seven calendar days from the last land-disturbing activity. The Design-Build Team shall label all slopes subject to the seven-day ground cover stabilization requirements on all Erosion and Sedimentation Control Plans submitted to the Department for review and acceptance.

- 5.2.2. For the slopes noted below, temporary and / or permanent ground cover stabilization shall be provided within 14 calendar days from the last land-disturbing activity:

- Slopes between 2:1 and 3:1, with a slope length of ten feet or less
- Slopes 3:1 or flatter, with a slope length of 50 feet or less
- Slopes 4:1 or flatter

- 5.2.3. Temporary and / or permanent ground cover stabilization shall be provided in accordance with the provisions in this RFP, the Vegetation Management Procedure developed by the Design-Build Team and the August 1, 2016 NCG-010000 General Construction Permit.

5.3. Additional Ground Cover Stabilization Requirements

- 5.3.1. Once the Design-Build Team identifies the area for stabilization due to inactivity, the Design-Build Team shall obtain concurrence from the Engineer and adhere to the following options based on the estimated amount of time the area will remain inactive. If the area stabilized exceeds the estimated timeframe, the Design-Build Team shall implement the next level of stabilization as directed by the Engineer. All application rates noted below are in pounds per acre.

5.3.2. Short Term Stabilization - For areas that will remain inactive for up to 21 days

- Erodible areas shall be stabilized utilizing non-vegetative cover. Non-vegetative cover options include straw mulch, hydraulic applied erosion control products or rolled erosion control products. If straw mulch is used, it shall provide 100% groundcover and be tacked sufficiently to hold the mulch in place for the duration of the inactive period. All other methods shall be installed according to the manufacturer’s directions.

5.3.3. Mid-Term Stabilization - For areas that will remain inactive for up to 90 days

- Erodible areas shall be stabilized utilizing the following stabilization protocol:

March 1 - August 31

50# German or Browntop Millet
 500# Fertilizer
 4000# Limestone

September 1 - February 28

50# Rye Grain or Wheat
 500# Fertilizer
 4000# Limestone

- At the Engineer’s sole discretion, the use of limestone on sandy soils that require topsoil for stabilization may be eliminated. The Design-Build Team shall consult with, and obtain written approval from, the NCDOT Roadside Environmental Unit prior to eliminating limestone.
- Upon obtaining written approval from the Engineer, the Design-Build Team may use wood mulch and / or ground clearing and grubbing debris as an option for Mid-Term Stabilization. If approved, the aforementioned mulch and / or debris shall be installed at a thickness that prevents erosion.

5.3.4. Long Term Stabilization - For areas that will remain inactive for more than 91 days

- Erodible areas shall be stabilized utilizing the following stabilization protocol:

All Roadway Areas

March 1 – August 31

10# Centipede *
 50# Tall Fescue Cultivars **
 25# Bermudagrass (hulled)
 500# Fertilizer
 4000# Limestone

September 1 – February 28

10# Centipede *
 50# Tall Fescue Cultivars **
 35# Bermudagrass (unhulled)
 500# Fertilizer
 4000# Limestone

* On cut and fill slopes 2:1 or steeper, the Design-Build Team shall apply centipede at a rate of five pounds per acre.

Riparian and Wetland Locations

March 1 – August 31

18# Creeping Red Fescue Cultivars ***
 6# Indiangrass
 8# Little Bluestem
 4# Switchgrass
 25# Browntop Millet
 500# Fertilizer
 4000# Limestone

September 1 – February 28

18# Creeping Red Fescue
 Cultivars ***
 6# Indiangrass
 8# Little Bluestem
 4# Switchgrass
 35# Rye Grain
 500# Fertilizer
 4000# Limestone

Waste and Borrow Areas

March 1 – August 31

75# Tall Fescue Cultivars **
 25# Bermudagrass (hulled)
 500# Fertilizer
 4000# Limestone

September 1 – February 28

75# Tall Fescue Cultivars **
 35# Bermudagrass (unhulled)
 500# Fertilizer
 4000# Limestone

** Approved Tall Fescue Cultivars

06 Dust	Escalade	Justice	Serengeti
2 nd Millennium	Essential	Kalahari	Shelby
3 rd Millennium	Evergreen 2	Kitty Hawk 2000	Sheridan
Apache III	Falcon IV	Legitimate	Signia
Avenger	Falcon NG	Lexington	Silver Hawk
Barlexas	Falcon V	LSD	Silverstar
Barlexas II	Faith	Magellan	Shenandoah Elite
Bar Fa	Fat Cat	Matador	Sidewinder
Barrera	Festnova	Millennium SRP	Skyline
Barrington	Fidelity	Monet	Solara
Barrobusto	Finelawn Elite	Mustang 4	Southern Choice II
Barvado	Finelawn Xpress	Ninja 2	Speedway
Biltmore	Finesse II	Ol' Glory	Spyder LS
Bingo	Firebird	Olympic Gold	Sunset Gold
Bizem	Firecracker LS	Padre	Taccoa
Blackwatch	Firenza	Patagonia	Tanzania
Blade Runner II	Five Point	Pedigree	Trio
Bonsai	Focus	Picasso	Tahoe II
Braveheart	Forte	Piedmont	Talladega
Bravo	Garrison	Plantation	Tarheel
Bullseye	Gazelle II	Proseeds 5301	Terrano
Cannavaro	Gold Medallion	Prospect	Titan Ltd

Catalyst	Grande 3	Pure Gold	Titanium LS
Cayenne	Greenbrooks	Quest	Tracer
Cessane Rz	Greenkeeper	Raptor II	Traverse SRP
Chipper	Gremlin	Rebel Exeda	Tulsa Time
Cochise IV	Greystone	Rebel Sentry	Turbo
Constitution	Guardian 21	Rebel IV	Turbo RZ
Corgi	Guardian 41	Regiment II	Tuxedo RZ
Corona	Hemi	Regenerate	Ultimate
Coyote	Honky Tonk	Rendition	Venture
Darlington	Hot Rod	Rhambler 2 SRP	Umbrella
Davinci	Hunter	Rembrandt	Van Gogh
Desire	Inferno	Reunion	Watchdog
Dominion	Innovator	Riverside	Wolfpack II
Dynamic	Integrity	RNP	Xtremegreen
Dynasty	Jaguar 3	Rocket	
Endeavor	Jamboree	Scorpion	

*** Approved Creeping Red Fescue Cultivars

Aberdeen Boreal Epic Cindy Lou

- From January 1 – December 31, the Design-Build Team shall apply an additional 20# of Sericea Lespedeza on cut and fill slopes 2:1 or steeper.
- Fertilizer shall be 10-20-20 analysis or a different analysis that provides a 1-2-2 ratio applied at a rate that provides the same amount of plant food as a 10-20-20 analysis and as directed.

5.4. Soil Analysis

If vegetation establishment indicates a deficiency in soil nutrients or an incurred pH level is present, the Design-Build Team shall take soil samples and apply additional soil amendments to the affected area and as directed.

5.5. Fertilizer Topdressing

- 5.5.1. In accordance with the requirements noted below, the Design-Build Team shall apply a minimum of one Fertilizer Topdressing application to all permanently seeded areas immediately prior to completion of the project, twice during every growing season from April 1st through September 30th, and at other times as directed.
- 5.5.2. Fertilizer used for topdressing shall be 10-20-20 analysis applied at a rate of 500 pounds per acre; or a different analysis that provides a 1-2-2 ratio applied at a rate that provides the same amount of plant food as a 10-20-20 analysis and as directed.
- 5.5.3. Fertilizer used for waste and borrow areas shall be 16-8-8 grade applied at a rate of 500 pounds per acre; or a different analysis that provides a 2-1-1 ratio applied at a rate that provides the same amount of plant food as a 16-8-8 analysis and as directed.

5.6. Supplemental Seeding

- 5.6.1. For all supplemental seeding, the kinds of seed and proportions shall be the same as specified above for *Long Term Stabilization*. The rate of application for supplemental seeding shall be between 25# to 75# per acre. Prior to topdressing, the Design-Build Team shall determine the actual rate per acre for supplemental seeding and submit the supplemental seeding rate and areas to the Department for review and acceptance.
- 5.6.2. To prevent disturbance of existing vegetation, minimum tillage equipment, consisting of a sod seeder, shall be used to incorporate seed into the soil where degree of slope allows. Where degree of slope prevents the use of a sod seeder, a clodbuster (ball and chain) may be used.

5.7. Mowing

The minimum mowing height shall be four inches.

6. EROSION CONTROL DAMAGES

6.1. Damages

- 6.1.1. The Design-Build Team shall observe and comply with Federal and State Laws, Local Laws, Ordinances, and Regulations; as well as Orders and Decrees of Bodies having any jurisdiction or authority in accordance with Section 107 of the 2018 NCDOT *Standard Specifications for Roads and Structures*.
- 6.1.2. The Design-Build Team shall take all reasonable precautions to comply with all regulations of all authorities having jurisdiction over public and private land governing the protection of erosion and sedimentation. Any fines, remediation required or charges levied against the Department for failing to comply with all rules and regulations concerning erosion and sediment control, due to the Design-Build Team's negligence, carelessness, or failure to implement the Erosion and Sedimentation Control Plans and Specifications; or failure to maintain an approved Storm Water Pollution Prevention Plan (SWPPP), regardless of absence of neglect, shall be deducted from monies due the Design-Build Team. In addition to said fines, remediation required, or charges levied, any associated engineering costs or actions taken by the Department in order for the Department to comply with rules and regulations, as a result of the Design-Build Team's negligence, carelessness, or failure to implement the Erosion and Sedimentation Control Plans and Specifications; and / or the SWPPP, regardless of absence of neglect, shall be deducted from the monies due to the Design-Build Team.

TRAFFIC SIGNALS AND SIGNAL COMMUNICATIONS SCOPE OF WORK (~~12-14-18~~1-10-19)**1. GENERAL****1.1. General Scope**

1.1.1. The Design-Build Team shall design and prepare plans for the temporary traffic signal installations required by the construction phasing and / or detour routes, permanent traffic signal installations, traffic signal revisions, and signal communication plans for connection to municipal signal systems and/or Division 5 standalone closed-loop signal systems. This work shall include, but not be limited to, the preparation of Traffic Signal Plans, Metal Pole Loading Diagrams, Electrical and Programming Details, Utility Make-Ready Plans, Signal Communication Plans, Wireless Communication Plans (for temporary signals), and Project Special Provisions. These plans shall be prepared in accordance with the *NCTA Design-Build Submittal Guidelines* and the *Guidelines for the Preparation of ITS & Signal Plans by Private Engineering Firms* available on the Design-Build Unit's website located at:

<https://connect.ncdot.gov/letting/Pages/Design-Build-Resources.aspx>

- 1.1.2. Except as noted otherwise in this RFP, the Design-Build Team shall maintain, monitor and adjust the traffic signals, both vehicle and pedestrian, as needed throughout the project construction. The Design-Build Team shall be responsible for the design and implementation of all temporary signal designs, including but not limited to signal system timing plans, needed to maintain vehicular and pedestrian traffic during construction, and all final traffic signal timing plans for the ultimate traffic configurations. If necessary, temporary traffic signal designs and implementation, shall include, but not be limited to, new local controller, signal timing, cables, poles, signal span, controllers, cabinets, and / or signal heads (vehicular or pedestrian). Prior to implementation, all signal system timing plans shall be reviewed and accepted by the NCDOT ITS and Signal Unit.
- 1.1.3. Throughout the project construction, the Design-Build Team shall maintain full actuation of the traffic signals located within the project limits, unless allowed otherwise by the Engineer in writing.
- 1.1.4. The Design-Build Team shall incorporate all traffic signals on this project into their respective signal system, as detailed below. To connect sidewalk networks, the Design-Build Team shall provide crosswalks and pedestrian signal heads for all approaches, as appropriate, based on field conditions. Crosswalks and pedestrian signal heads will not be required in a quadrant where there is no sidewalk.
- 1.1.5. Depending on the intersection design, new permanent signal installations shall utilize galvanized metal strain poles or metal poles with mast arms for support. All temporary signal installations may utilize wood poles for signal supports. All plans and associated design material and specifications shall be reviewed and accepted by NCDOT before installation.
- 1.1.6. Prior to final design and installation, the Design-Build Team shall coordinate all signal phasing recommendations with the Division 5 Traffic Engineer, the Regional Traffic Engineer, and the NCDOT ITS & Signals Unit.

- 1.1.7. The Design-Build Team shall coordinate and implement all signal designs at the appropriate time as directed by the Engineer. Prior to placing traffic in a new pattern, all traffic signals shall be installed and operational, including but not limited to, signal system timing plans and interconnection to the Signal System, if required below.

1.2. Pre-Design Coordination

- 1.2.1. A pre-design meeting shall take place between the NCDOT ITS & Signals Unit, the Design-Build Team, Division 5 Traffic Engineer, Regional Traffic Engineer and any other pertinent NCDOT personnel. All Traffic Signal and Signal Communications Plan submittals shall be submitted for review to the NCDOT ITS & Signals Unit. Additionally, plans shall be concurrently submitted to the appropriate authorities in which the plans are associated (i.e. Division 5 personnel, etc.) for comments. However, final approval on all Traffic Signal and Signal Communications Plans submittals will ultimately be the responsibility of the NCDOT ITS & Signal Unit. All Traffic Signal and Signal Communications Plans shall be accepted by the ITS & Signals Unit prior to beginning traffic signal construction or plan implementation.
- 1.2.2. The Design-Build Team shall select a Private Engineering Firm (PEF) that has experience designing and sealing Traffic Signal and Signal Communications Plans for NCDOT on comparable projects. The Design-Build Team shall select a Private Engineering Firm (PEF) that is currently pre-approved by the NCDOT to work on signal system timing projects.

1.3. Disposal of Existing Equipment

- 1.3.1. The Design-Build Team shall deliver all existing cabinets and their contents, including but not limited to fiber modems, telephone modems, radio equipment, that are not reinstalled on this project to the Division 5 Traffic Services Office (1076 Prison Camp Road, Durham, 27705). The Design-Build Team shall exercise care to ensure the equipment is not damaged during removal, storage, and delivery.
- 1.3.2. The Design-Build Team shall dispose of and / or retain ownership of all other traffic signal equipment.
- 1.3.3. Unless noted elsewhere in this RFP, the Design-Build Team shall return all existing electronic equipment to the Department. A minimum of one week prior to removal of electronic equipment, the Design-Build Team shall contact the Engineer during normal business hours, to coordinate a specific day and time for the Design-Build Team to deliver the salvaged material to the Department. Prior to delivery to the Department, the Design-Build Team shall stockpile all salvaged material to prevent damage.

1.4. Signal Inventory Numbers

Signal Inventory Numbers (SIN) will be assigned for each new signalized location by the NCDOT ITS & Signals Unit. Once all the traffic signal locations have been finalized and accepted by the Department, the Design-Build Team shall submit a written request for the SIN(s) to the NCDOT ITS & Signals Unit, via the NCTA. At a minimum, this request shall list each signal location that requires a SIN and include the following:

- County
- Nearest Municipality
- Names of all intersecting roads that will be under signal control, including state route numbers (Interstate, US, NC or SR) and common street names
- The dominant through movement

1.5. Principle Standards

1.5.1. The Design-Build Team shall be responsible for providing a safe and economical design for the public. The Design-Build Team shall prepare all plans and designs in accordance with the current ITS & Signals Unit design standards, including but not limited to, the version of the following documents effective on the Technical Proposal submittal date:

- NCDOT *Standard Specifications for Roads and Structures*
- NCDOT *Standard Roadway Drawings*
- ITS & Signals Unit Project Special Provisions
- ITS & Signals Unit Design Manual
- *Manual on Uniform Traffic Control Devices (MUTCD)*
- *North Carolina Supplement to the Manual on Uniform Traffic Control Devices (NCMUTCD)*
- *Guidelines for the Preparation of ITS & Signal Plans by Private Engineering Firms*
- Traffic Systems Operations' Project Special Provisions - (Special Provisions for the Preparation of Coordinated Traffic Signal System Timing Plans – Version 2011.1)

1.5.2. Links to additional ITS & Signals Unit design standards and aides are available on website noted below:

<https://connect.ncdot.gov/resources/safety/Pages/ITS-and-Signals.aspx>

2. TRAFFIC SIGNALS

The Design-Build Team shall provide ~~five (5)~~ six (6) new traffic signals; and modify ~~one (1)~~ three (3) existing traffic signals. One (1) modified signal, and relocate one (1) existing will be taken out of service when traffic signal is shifted to the new alignment. The signals shall be interconnected as noted in the tables below. (Reference Section III for the system interconnection requirements.) The traffic signal detection for the final traffic patterns shall be inductive loop detection unless otherwise approved in advance by the ITS & Signals Unit. The Design-Build Team may provide video detection only for temporary traffic patterns during construction. Unless allowed elsewhere in this RFP, the required traffic signal work and signal communications for each intersection are listed below:

NCDOT – Division 5 – Relocated <u>Modify</u> Existing Isolated Signal		
Signal Inventory Number	Intersection Description	Work Requirements
<p>05-2122- (Existing)</p>	<p>SR 1152 (Holly Springs Rd.) at SR 1300 (Kildaire Farm Rd.)</p>	<p>Design and install a new, fully actuated traffic signal. Modify the <u>existing</u> traffic signal as needed to match all temporary construction phasing and the proposed final traffic pattern. This may require signal phasing changes, signal head changes, system detectors and/or system interconnection equipment.</p> <p>Install new galvanized metal strain poles with span wire or metal poles with mast arms at the new (final) location.</p> <p><u>Take traffic signal out of service when traffic is shifted to the new alignment.</u></p>
BECOMES		
<p><u>05-TBD (NEW)</u></p>	<p>SR 1152 (Holly Springs Rd.) at SR 1300 (Kildaire Farm Rd.) and SR 3921 (Sancroft Dr.)</p>	<p>This signal is not part of any existing traffic signal system. Incorporate this <u>the new</u> signal into the future (TBD Let) Holly Springs Closed-loop Signal System (Operated by Division 5).</p> <p>Design and install new, fully actuated traffic signal with 2070 controller operating ASC/3 or OASIS Software, in a 170 cabinet with an auxiliary output file, including base extender. The operating software shall be finalized at the pre-design meeting.</p> <p>Provide Flashing Yellow Arrow signal heads at all protected/permissive and permissive left turns and U-turns, if appropriate, including time of day phasing options.</p>

NCDOT – Division 5 – Modify Existing Isolated Signal		
Signal Inventory Number	Intersection Description	Work Requirements
05-0879 (Existing)	SR 1152 (Holly Springs Rd.) at SR 1301 (Sunset Lake Rd.)	<p>Modify this existing traffic signal as needed to match all temporary construction phasing and the proposed final traffic pattern. This may require signal phasing changes, signal head changes, system detectors and/or system interconnection equipment.</p> <p>Existing metal poles with mast arms may be retained.</p> <p>This signal is not part of any existing traffic signal system. Incorporate this signal into the future (TBD Let) Holly Springs Closed-loop Signal System (Operated by Division 5).</p> <p>Modify existing fully actuated traffic signal. Use 2070 controller operating ASC/3 or OASIS Software in a 170 cabinet with an auxiliary output file, including base extender. The operating software shall be finalized at the pre-design meeting.</p> <p>Provide Flashing Yellow Arrow signal heads at all protected/permissive and permissive left turns and U-turns, if appropriate, including time of day phasing options.</p>

NCDOT – Holly Springs Closed-loop System – New Signals		
Signal Inventory Number	Intersection Description	Work Requirements
05-TBD (NEW)	SR 1152 (Holly Springs Rd.) at Toll NC 540 WB Ramps	Design and install a new, fully actuated traffic signal with 2070 controller operating ASC/3 or OASIS Software, in a 170 cabinet with an auxiliary output file, including base extender. The operating software shall be finalized at the pre-design meeting.
and		Provide Flashing Yellow Arrow signal heads at all protected/permissive and permissive left turns and U-turns, if appropriate, including time of day phasing options.
05-TBD (NEW)	SR 1152 (Holly Springs Rd.) at Toll NC 540 EB Ramps	Install new galvanized metal strain poles with span wire or metal poles with mast arms (preferred) at this location.
and		Incorporate these signals into the future (TBD Let) Holly Springs Closed-loop Signal System.
05-TBD (NEW)	SR 1152 (Holly Springs Rd.) at Lockley Rd.	Wireless equipment may be used to temporarily interconnect the signals along this corridor. However, at the completion of the project, the signals shall be connected using fiber optic cable as described in Section 3.1.1 of this Scope of Work.

NCDOT – Division 5 – Modify Existing Isolated Signal		
Signal Inventory Number	Intersection Description	Work Requirements
05-1999 (Existing)	NC 55 Bypass at NC 55 (E. Williams St.) and SR 1191 (Technology Dr.)	<p>Modify this existing traffic signal as needed to match all temporary construction phasing and the proposed final traffic pattern. This may require signal phasing changes, signal head changes, system detectors and/or system interconnection equipment.</p> <p>Existing wood poles may be retained.</p> <p>This signal is not part of any existing traffic signal system. Incorporate this signal into the NC 55 Bypass Closed-loop Signal System (Operated by Division 5).</p> <p>Modify existing fully actuated traffic signal. Use 2070 controller operating ASC/3 or OASIS Software in a 170 cabinet with an auxiliary output file, including base extender. The operating software shall be finalized at the pre-design meeting.</p> <p>Provide Flashing Yellow Arrow signal heads at all protected/permissive and permissive left turns and U-turns, if appropriate, including time of day phasing options.</p>

- NC55 Bypass Closed-loop Signal System (operated by Division 5) – Ethernet communications using 48 Fiber Trunk Cable with 12 Fiber Drop Cable to the cabinet (Details of this closed-loop system are to be determined).

3.1.2. Reference the ITS Scope of Work found elsewhere in this RFP for additional ITS requirements.

3.2. PLANS AND SUBMITTALS

3.2.1. The Signal Communications and Conduit Routing Plans shall consist of the four (4) major items listed below:

- Traffic Signal Plans
- Signal Communications Plans including Splice Plans
- Project Special Provisions
- Catalog Cut Sheets

3.2.2. Prior to construction, the Design-Build Team shall provide a detailed set of Signal Plans, Signal Communications Plans, Project Special Provisions and Catalog Cut Sheets as required above for the Department’s review and acceptance. No construction related to the installation of these systems shall begin until NCDOT has accepted the RFC Plans.

3.3. Utility Make-Ready Plans

3.3.1. In conjunction with the development of the Traffic Signals and Signal Communications Plans, the Design-Build Team shall also develop, if applicable, a set of Utility Make-Ready Plans. The Design-Build Team shall schedule coordination meetings with each affected utility owner and pertinent NCDOT personnel.

3.3.2. The Design-Build Team shall install all traffic signal equipment, communications cables and conduit systems in such a manner that avoids conflicts with other utilities. All aerial communications cable installations shall be installed in accordance with the National Electrical Safety Code. The Design-Build Team shall be responsible for coordinating all Utility Make Ready Work with the proper utility representatives.

4. MATERIALS

4.1. New Equipment Required

When existing equipment (signal cabinets, hub cabinets, Ethernet equipment, electronic equipment, fiber, conduit, messenger cable, etc.) is replaced, the Design-Build Team shall replace existing equipment with new equipment. All material, equipment and work shall adhere to the *Standard Specifications for Roads and Structures* requirements. Materials, where applicable, shall be pre-approved on the Department’s QPL. The QPL web site is:

<https://connect.ncdot.gov/resources/safety/Pages/default.aspx>

4.2. Material Specifications

Prior to incorporation, the Design-Build Team shall provide detailed specifications for all material, equipment and/or work that is not covered in the 2018 *Standard Specifications for Roads and Structure* for Department approval. The Design-Build Team shall provide specifications and plans that address the material requirements and construction methods. No equipment or material shall be installed until it has been approved by the Department in writing. Catalog cuts will not be required for items on the QPL. Items not listed on the QPL shall require Department written approval prior to incorporation.

5. MAINTENANCE AND REPAIR REQUIREMENTS

From the beginning of construction until the final project acceptance, the Design-Build Team shall maintain and repair all system components within the project scope, including but not limited to, signal cabinets, loops, signal heads, conduit systems, communications lines, splice cabinets, etc. After project acceptance, the Design-Build Team shall perform all system repairs resulting from faulty materials and/or workmanship, in accordance with the *Three Year Guarantee Project Special Provision* found elsewhere in this RFP, or longer if the Design-Build Team extends the warranty period.

6. PLAN OF RECORD DOCUMENTATION

The Design-Build Team shall prepare and submit to the Department Plan of Record (POR) documentation that depicts the conduit and equipment device locations. The Design-Build Team shall submit final POR documentation in electronic and hard copy format for acceptance by the Department. At a minimum, the POR documentation shall include, but not be limited to, the following:

- Electronic plans in MicroStation (latest release in use by the Department) format on CD
- Hard copy documentation on 22 x 34-inch plan sheets
- Final location and depth of conduits, wiring external to the cabinets, locations of splice closures, junction box locations, and SMFO cable terminations
- Real world coordinates for all devices, splice enclosures, junction boxes, and equipment cabinets installed or utilized under this project
- Coordinates in English units using the North Carolina State Plane coordinate system (1983 North American Datum also known as NAD '83)
- Coordinates that do not deviate more than 1.7 feet in the horizontal plane and 3.3 feet in the vertical plane. Global positioning system (GPS) equipment able to obtain the coordinate data within these tolerances may be used

7. LOCAL AREA NETWORK

7.1. Ethernet Systems

For the closed-loop systems (only), the Design-Build Team shall provide, install and make operational Ethernet edge switches in all cabinets, with associated 1E communications modules.

For all Ethernet based systems the Design-Build Team shall furnish and install media access control (MAC) addresses for all equipment utilized as part of this project. MAC address labels shall be affixed to each device utilized. IP addresses shall be furnished for all equipment utilized as part of this project. When replacing existing equipment or installing new equipment, IP address information shall be obtained from the equipment operator to ensure proper operations within their respective systems. Final IP address labels shall be affixed to each device utilized. LAN equipment shall be fully integrated, providing local device failover and fault tolerance, virus protection, user authentication, and security functions to prevent unauthorized user and data from entering the LAN.

7.2. Plans and Architecture

7.2.1. The Design-Build Team shall ensure that all plans and designs conform to the NCDOT and NC Statewide IT Policies and Standards as described at:

<https://www.scio.nc.gov/mission/itPoliciesStandards.aspx>.

7.2.2. The Design-Build Team shall submit all architecture of the IT modules for review and approval by NCDOT IT and the NC Office of Information Technology architecture groups.

8. INTEGRATION & TESTING

8.1. Integration

The Design-Build Team shall integrate each system device with its respective system, and work with the system operator to ensure that each device is functioning properly within the system.

8.2. Testing, Remedy for Deficiencies, and Reporting

8.2.1. The Design-Build Team shall develop unit and system test plans and procedures for each device and component and submit to the Engineer for review and approval. This includes, but is not limited to, signal equipment, fiber optic communications cable, local to central equipment/communications testing. Upon completion of the system installation and integration, the Design-Build Team shall conduct unit and system tests according to the approved test plans and procedures. The Design-Build Team shall be responsible for providing all necessary test equipment.

8.2.2. In case of failures and substandard performance, the Design-Build Team shall identify the cause of failure and/or substandard performance, repair or replace the faulty parts and components and repeat the test. If the problem persists, the Design-Build Team shall replace the entire unit causing the problem prior to repeating the test at no additional cost.

8.2.3. After successful completion of all units and system test, the Design-Build Team shall submit the test reports, along with the record of repairs and part replacements, to the Engineer.

9. SIGNAL SYSTEMS TIMING – CLOSED-LOOP SYSTEMS

9.1. Signal System Timing Coordination

The Design-Build Team shall develop and implement all temporary and final coordinated timings plans for the two closed-loop signal systems. This work shall include the design, implementation and fine-tuning of signal timing plans, and evaluation of the final operational benefits associated

with work performed on the project. The signal timing plans shall be designed to address all possible traffic needs within the project construction limits, including but not limited to:

- Weekday peak / non-peak traffic periods (i.e. a.m., p.m., noon, off-peak, etc.);
- School / Universities start / end and / or class change peak traffic periods;
- Seasonal traffic patterns;
- Pre-scheduled holiday(s) traffic patterns;
- Incident management traffic patterns (i.e. detour routes, hurricane evacuations, etc.); and
- Other special events traffic patterns.

9.2. Timing Plans

- 9.2.1. Design Build Team shall coordinate the number of timing plans with the Division and the Central Office System Timing (COST) Section. The Design Build Team shall submit a set of preliminary signal system timing plans, with supporting *Tru-Traffic*, *SYNCHRO* 9.0 (or later), and *Translink32* database files, to the COST Section. All Signal System Timing Plans shall be reviewed and accepted by the COST Section prior to implementation. The Design-Build Team shall coordinate the development and implementation of all signal system timing plans at the appropriate times, as directed by the Engineer.
- 9.2.2. The Design Build Team shall field implement signal system timing plans in accordance with the COST Section's requirements. In the event of conflicting design parameters in the requirements noted above, the proposed design shall adhere to the most conservative values. The Design-Build Team shall:
- 9.2.3. Ensure all signal system timing plans are operational in the Central Control Center, Master and local controller(s)
- 9.2.4. Observe new traffic operations at the intersections and along the corridor and collect trip logs for each signal system timing plan implemented, by riding the system with *Tru-Traffic* synched with the plan in operation at the time
- 9.2.5. Fine-tune signal system timing plans, as necessary, for optimal system performance.
- 9.2.6. Prior to Final Project Acceptance, the Design-Build Team shall submit a final report, including final implemented signal timing plans and all supporting documents in *SYNCHRO* 9.0 (or later), *Tru-Traffic* Reports and data, *Translink32* database files to the COST Section and Division 5.

GEOENVIRONMENTAL SCOPE OF WORK

(10-18-18)

1 DEFINITION

For the purpose of this Scope of Work, contamination/contaminants are defined as any substance that when discharged in any quantity may present an imminent and substantial danger to the public health or welfare. Petroleum is defined as any petroleum-derived product of any kind and in any form including, but not limited to, crude oil, diesel fuel, fuel oil, gasoline, lubrication oil, oil refuse, oil mixed with other waste, oil sludge, petroleum related products or by-products, and all other liquid hydrocarbons, regardless of specific gravity, whether occurring singly or in combination with other substances.

2 DESCRIPTION OF WORK**2.1 Sites of Concern**

- 2.1.1 Sites of concern were identified as part of the June 17, 2014 *GeoEnvironmental Report for Planning Revision 2*. The Department will investigate these known sites of concerns based on the current Right of Way Plans and provide Right of Way Acquisition Recommendations to the Right of Way Firm. The Right of Way Acquisition Recommendations will be completed prior to the Right of Way Firm making offers to purchase the right of way at these sites of concern.
- 2.1.2 In the event the Design-Build Team modifies the Right of Way Plans in the vicinity of sites of concern, the Design-Build Team shall notify the NCTA, in writing. The Department will require 90 days from the date of receipt of the modified Right of Way Plans to investigate and provide Right of Way Acquisition Recommendations. The Right of Way Acquisition Recommendations shall be completed prior to the Design-Build Team or Right of Way Firm making offers to purchase the right of way on sites of concern.
- 2.1.3 The Design-Build Team shall adhere to all Right of Way Unit procedures regarding the acquisition of contaminated property and all Right of Way Acquisition Recommendations provided by the Department. After the parcels with identified contamination and/or underground storage tanks (USTs) are acquired and cleared of all above ground structures, the Department will 1) remove from the right of way USTs identified in the June 17, 2014 *GeoEnvironmental Report for Planning Revision 2* and discovered during the property appraisals and 2) remove all associated contaminated soil anticipated to require excavation to complete the project. The Department will remove the aforementioned USTs and contaminated soil within 60 days of written notification that the above-ground structures have been removed. All contaminated soil not required for removal to complete the project shall be left in place and undisturbed.
- 2.1.4 If groundwater is encountered and dewatering is required in areas of known contamination, the Design-Build Team shall containerize the groundwater in vessels provided by the Department. The Department will be responsible for the sampling and disposal of the water.

2.1.5 It is important to note that petroleum contaminated soil may be encountered during any earthwork activity on this project.

3 UNKNOWN CONTAMINATED SITES

The Design-Build Team shall immediately notify the Department if the Design-Build Team's operations encounter or expose any abnormal condition that may indicate the presence of a hazardous, contaminated, and/or toxic material not previously identified. If the Engineer elects to have the Design-Build Team remove and dispose of contaminated material, the removal and disposal of this material shall be performed as extra work in accordance with Article 107-25 of the 2018 NCDOT *Standard Specifications for Roads and Structures*.

4 INFORMATION PROVIDED BY NCDOT

- *GeoEnvironmental Report for Planning Revision 2*, June 17, 2014
- Microstation GeoEnvironmental File *R-2721_R-2828_R-2829_Geo_env.dgn*

ITS SCOPE OF WORK~~(1-7-18)~~1-10-19**1. GENERAL REQUIREMENTS****1.1. Scope Overview**

- 1.1.1. Design, furnish, and install new ITS devices, infrastructure and communications cable system near and along the project. Interconnect the new fiber-optic communications cables with fiber-optic communications cable to be installed under the R-2721B project and the existing fiber-optic cable. Major items of work include, but are not limited to, the following:
- Civil infrastructure (including metal poles) for six (6) new Closed-Circuit Television (CCTV) cameras
 - Civil infrastructure (including metal poles) for eight (8) new Microwave Vehicle Detection (MVD) sites
 - Civil infrastructure (including sign pedestals, conduit, junction boxes) to support Wrong-Way Driver Notification Signs at mainline and ramp sites
 - ~~Two (2)~~Three (3) new Dynamic Message Signs (DMS):
 - ~~One~~Two (1) Type A on pedestal mount on shoulder
 - One (1) Type B on toll gantry structure
 - Conduit System (four – 2-inch conduits for communication and one – 2-inch conduit for electrical)
 - Approximately four (4) miles of 2x144-fiber single-mode fiber-optic communications cable with tracer wire
 - Fiber-optic drop cable assemblies with tracer wire
 - Junction boxes
 - Splice enclosures
 - Hub/splice cabinets
 - Electrical service equipment
 - Local Area Network equipment installation and configuration
- 1.1.2. Provide materials and perform all work in accordance with the 2018 NCDOT *Standard Specifications for Roads and Structures*, the 2018 NCDOT *Roadway Standard Drawings*, the Project Special Provisions and the *NCTA ITS Standard Details* dated May 24, 2018. In case of a conflict, the latter shall govern.
- 1.1.3. Prior to any underground work, locate existing utilities, communications cable, power cable, and adjust work activities to protect these facilities. Immediately cease work and notify the Engineer and affected owners if damage to existing utilities occurs. Repair damages to utilities, communications cable, and power at no cost to the Department.
- 1.1.4. The Design-Build Team shall repair all damage caused by the Design-Build Team to any existing ITS infrastructure located inside or outside the project limits; and shall re-establish communications and full device functionality to damaged ITS infrastructure within 24 hours of the discovery of the damage by NCDOT.

- 1.1.5. Determine the location of each ITS device, obtain the Engineer's approval of the locations. Furnish and install guardrail to protect the ITS device locations, as required. The Design-Build Team shall locate and design the DMS to maintain MUTCD required sign spacing and sight distances. The Design-Build Team shall adhere to the MUTCD edition effective on the Technical Proposal submittal date.
- 1.1.6. The Design-Build Team is responsible for providing meter service assemblies for all ITS and toll devices / sites.
- 1.1.7. The communications infrastructure shall consist of an underground conduit system including conduit, tracer wire, junction boxes and heavy-duty junction boxes. As described herein, the Design-Build Team shall design and install the complete conduit system to service all ITS devices and toll facilities within or affected by the project.
- 1.1.8. All communications between the proposed ITS field devices and the local hub shall utilize Ethernet technology over single-mode fiber-optic cable. The Design-Build Team shall install Ethernet edge switches (provided and configured by NCDOT) and related equipment for the ITS network/cable only.
- 1.1.9. The Design-Build Team shall furnish and install fiber-optic cable as described in the "Communications" section in this Scope of Work and as shown in the most recent version of the *Complete 540 ITS and AET Concept Plans* provided by NCTA and posted to the R-2721A Connect site, and/or as allowed otherwise by approved plan deviations. The Design-Build Team shall furnish and install fiber-optic splice/termination centers for ITS cabinets.
- 1.1.10. Refer to the Traffic Signals and Signal Communications Scope of Work for additional ITS and fiber-optic communications requirements.

1.2. Coordination with Toll Systems Integrator

- 1.2.1. The NCTA will enter into an agreement with a Toll Systems Integrator (TSI), to design, develop, install, test and operate the roadside toll AET equipment for the project. A responsibility matrix is provided below to differentiate the responsibilities of the Design-Build Team ("DBT") and the Toll Systems Integrator ("TSI"):

	Feature								
	Splice Enclosure in Splice Box	Pole or Structure(s)	Electrical Service, Power Drop Conduit & Meter Panel	Comms Drop Conduit and FO Drop Cable	Cabinet(s)	Ethernet Switch	Establish Network Communications	Furnish, Install & Locally Test Device(s)	Integration ³
DMS Sites	DBT	DBT	DBT	DBT	DBT	NCDOT ²	DBT	DBT	TSI
CCTV Camera Sites	DBT	DBT	DBT	DBT	DBT	NCDOT ²	DBT	TSI	TSI
Microwave Vehicle Detector Sites	DBT	DBT	DBT	DBT	DBT	NCDOT ²	DBT	TSI	TSI
Fiber-Optic Conduit and Cable				DBT	DBT ¹			DBT ⁵	TSI
Wrong Way Detection System	TSI	DBT	TSI	DBT	TSI	TSI	TSI	TSI	TSI
AET Toll Zone	DBT	DBT	DBT	DBT ⁴	TSI	TSI	TSI	TSI	TSI

Note 1: Hub/Splice Cabinets
Note 2: Ethernet edge and hub switches to be furnished and configured by NCDOT and installed by DBT
Note 3: Integration provides a fully functional/operational end-to-end system from the TRTMC
Note 4: TSI supplies all LAN cable at/for the toll sites (Ethernet, Multi-Mode Fiber, etc.). All toll zone conduit provided by DBT.
Note 5: DBT proofs all SMFO cable runs/fibers with OTDR

2. PROJECT OPERATION REQUIREMENTS

2.1. Intermediate Contract Time #7 for Failure to Repair a Damaged ITS Fiber-optic Communications Cable and Restore Communication

The Design-Build Team shall repair all existing fiber-optic communication cables damaged during construction. The Design-Build Team shall immediately report damages to the Engineer and TRTMC at 1-877-627-7862. The Design-Build Team shall repair all damages within 24 hours at no cost to the Department. The Design-Build Team shall bring all affected ITS fiber-optic communication cables back on line within the same 24 hours. A “damaged” ITS fiber-optic communications cable is any fiber communications cable that is determined damaged due to an accidental or unscheduled outage event.

Liquidated Damages for Intermediate Contract Time #7 for failure to repair a damaged ITS fiber-optic communications cable and restore communication within 24 hours are \$500.00 per hour or any portion thereof.

2.2. Intermediate Contract Time #8 and #9 for Failure to Reestablish ITS Fiber Communications

During construction, the Design-Build Team shall coordinate any disruption in ITS fiber-optic communications with the Engineer and the TRTMC. The Design-Build Team shall notify the Engineer and the TRTMC a minimum of seven days prior to all proposed disruptions in service. A minimum of 21 days prior to any disruption in ITS fiber-optic communications, the Design-Build Team shall develop and provide a plan for the Department’s approval that defines 1) an anticipated disruption timeframe and 2) a plan of action for reestablishing ITS communications within 72-hours.

Liquidated Damages for Intermediate Contract Time #8 for failure to reestablish ITS fiber-optic communications within 72 hours are \$2,500.00 per day or any portion thereof.

Liquidated Damages for Intermediate Contract Time #9 for failure to provide a plan that defines 1) an anticipated ITS fiber-optic communications disruption timeframe and 2) a plan of action for reestablishing ITS communications a minimum of 21 days prior to a proposed disruption in service are \$5,000.00 per failure.

3. DESIGN REQUIREMENTS

3.1. Communications

- 3.1.1. Design the field-to-center communication network for Gigabit fiber-optic Ethernet technology (provided by others). For all equipment not specified herein, provide product specifications for the Department's review and approval prior to incorporation. Furnish and install all field equipment within the project limits.
- 3.1.2. On the west end of the project, terminate the new 144-fiber ITS and toll cables on interconnect centers located in a new hub/splice cabinet near the location of existing CCTV-1 within the NC 55 Bypass interchange. Provide jumpers for 72 fibers of both new 144-fiber cables to connect to the corresponding fibers of the respective existing 72-fiber communications cables, or to the routing switch in the cabinet. Install jumpers as directed by NCTA.
- 3.1.3. On the east end of the project, terminate the new 144-fiber ITS and toll cables on interconnect centers located in a hub/splice cabinet (constructed by this project) located along Toll NC 540 just west of SR 1389 (Pierce Olive Road).
- 3.1.4. Relocate existing fiber-optic cable impacted by the construction of these projects. Potential impacts of existing NCDOT fiber-optic cable exist along SR 1152 (Holly Springs Rd.) for an proposed NCDOT closed-loop signal system, and within the NC 55 Bypass interchange. Communications to the traffic signals in the closed-loop system shall be maintained for the duration of the project.
- 3.1.5. The Design-Build Team shall generate splice plans and migration details for interfering with existing fiber for the Department's review and approval prior to beginning construction, if such interference is projected to occur.
- 3.1.6. Furnish and install new hub/splice equipment cabinets as defined in the *Communications Hardware* Project Special Provision found elsewhere in this RFP. Install new electrical service equipment at all new hub/splice cabinet locations, if the location is not shared with other ITS devices requiring power service.
- 3.1.7. In each toll zone vault, install a 19" computer equipment rack for terminating the toll zone fiber (and ITS drop cable fiber, if applicable). Reference the *Communication Hardware*

Project Special Provision found elsewhere in this RFP. Install an interconnect center in the rack accommodating at least 48 fibers; see “Fiber-Optic Splice Centers” section of this Scope of Work.

3.2. CCTV Camera Infrastructure

- 3.2.1. The Design-Build Team shall strategically locate and install steel poles (50 ft. minimum height) at six (6) new CCTV camera locations that provide optimum viewing and full coverage of all mainline and shoulder lanes, as well as ramps.
- 3.2.2. At a minimum, install CCTV camera sites at general locations as shown within the R-2721A portion of the *Complete 540 ITS and AET Concept Plans*.
- 3.2.3. Determine the exact location of each CCTV camera site, obtain the Engineer’s written approval of the locations, and install the poles and foundations. Furnish site surveys, including but not limited to bucket truck surveys, to ensure camera coverage areas are acceptable.
- 3.2.4. Design and install poles and foundations as defined in the *CCTV Camera and MVD Metal Pole* Project Special Provision found elsewhere in this RFP. Provide lowering devices for all CCTV camera poles.
- 3.2.5. Install new electrical service equipment at all new CCTV locations. Solar power assemblies will not be allowed. Comply with the National Electrical Code (NEC), the National Electrical Safety Code (NESC), the Standard Specifications, the Project Special Provisions, and all local ordinances. All work involving electrical service shall be coordinated with the appropriate utility company and the Engineer.
- 3.2.6. Furnish and install new Type 336A equipment cabinets mounted on the pole as defined in the *CCTV Camera Equipment Infrastructure* Project Special Provision found elsewhere in this RFP. Install the following minimum equipment in each CCTV equipment cabinet:
 - Power equipment including power supplies, circuit breakers, surge protectors, and other related materials.
 - Ethernet edge switch (provided by others)
 - Fiber-Optic interconnect center

3.3. Microwave Vehicle Detection Infrastructure

- 3.3.1. The Design-Build Team shall locate and install steel poles (20’ minimum height) for the ten (10) Microwave Vehicle Detection (MVD) sensors at the eight (8) MVD locations; the 2 mainline sites and 6 ramp sites are shown within the R-2721A portion of the *Complete 540 ITS and AET Concept Plans*. Refer to the *NCTA ITS Standard Details* dated May 24, 2018 for guidelines on the exact placement of MVD sites, obtain the Engineer’s written approval of the locations, and install the poles and foundations.

- 3.3.2. Design and install poles and foundations as defined in the *CCTV Camera and MVD Metal Pole* Project Special Provision found elsewhere in this RFP.
- 3.3.3. Install new electrical service equipment at all new MVD locations, with the following exceptions:
- Mainline sites require electrical service to only one side of the road (the sensor on the other side of the road can be assumed to be interconnected with serial cable provided by others).
 - Ramp MVD sites in close proximity (for instance, in the same quadrant of an interchange) can be assumed to share electrical service (i.e., they will be interconnected with serial cable provided by others).
- 3.3.4. Solar power assemblies will not be allowed. Furnish and install new equipment cabinets as defined in the *Microwave Vehicle Detection Infrastructure* Project Special Provision found elsewhere in this RFP. Comply with the National Electrical Code (NEC), the National Electrical Safety Code (NESC), the Standard Specifications, the Project Special Provisions, and all local ordinances. All work involving electrical service shall be coordinated with the appropriate utility company and the Engineer.
- 3.3.5. Install the following minimum equipment in each MVD master equipment cabinet:
- Power equipment including power supplies, circuit breakers, surge protectors, and other related materials.
 - Ethernet edge switch (provided by others)
 - Fiber-Optic interconnect center

3.4. Dynamic Message Signs

- 3.4.1. Furnish and install new DMS and associated equipment as defined in the *Dynamic Message Sign* Project Special Provision found elsewhere in this RFP. The DMS installed on this project shall be:
- Type A: Monochrome 66mm pixel pitch pedestal-mounted walk-in DMS
 - Type B: Color 20mm pixel pitch gantry-mounted front access DMS
- 3.4.2. Locate the ~~two~~three DMS as shown in the *Complete 540 ITS and AET Concept Plans* (and the R-2721A Signing Schematic dated ~~May 31, 2018~~January 11, 2019).
- 3.4.3. For Type A DMS: Install DMS on a single steel pedestal type structure with ladders, ladder safety cages, and walkways leading to the DMS maintenance access door. The bottom of each DMS should be 25 feet higher than the highest point of the roadway. Install DMS equipment in an approved equipment cabinet mounted on the structure.
- 3.4.4. The pedestal DMS installed shall be selected from the most current version of the NCDOT ITS & Signals Qualified Products List.

- 3.4.5. Determine the exact location of the DMS by coordinating with the Engineer. Obtain the Engineer's written approval of the locations prior to installation of the DMS.
- 3.4.6. Install a new electrical service equipment at all new DMS locations. Comply with the National Electrical Code (NEC), the National Electrical Safety Code (NESC), the Standard Specifications, the Project Special Provisions, and all local ordinances. All work involving electrical service shall be coordinated with the appropriate utility company and the Engineer.
- 3.4.7. For Type B DMS, install gantry-mounted DMS in accordance with *NCTA ITS Standard Details* dated May ~~31~~24, 2018. Type B DMS will receive electrical service from the toll site vault.
- 3.4.8. For both Type A and Type B DMS, install the following minimum equipment in each DMS equipment cabinet:
 - DMS controller
 - UPS and power equipment including power supplies, circuit breakers, surge protectors, and other related materials.
- 3.4.9. Perform all work in accordance with the *Dynamic Message Sign Project Special Provision* found elsewhere in this RFP, the 2018 NCDOT *Standard Specifications for Roads and Structures* and the 2018 NCDOT *Roadway Standard Drawings* and the *NCTA ITS Standard Details* dated May 24, 2018.

3.5. Wrong-Way Driver Notification Signs Infrastructure

- 3.5.1. Install conduit, junction boxes and Type III Pedestals at mainline toll sites as per Sheet W-1 of the *NCTA ITS Standard Details* dated May ~~31~~24, 2018. Type III Pedestals shall be in accordance with Sections 1098-14 and 1743 of the 2018 NCDOT *Standard Specifications for Roads and Structures*, as updated by the NCDOT *Signals and Intelligent Transportation Systems Project Special Provisions*, version 12.6.
- 3.5.2. Install conduit, junction boxes and fiber-optic cable in the vicinity of ramps as shown in the *Complete 540 ITS and AET Concept Plans* for the R-2721A portion. Fiber-optic cable for ramp sites (6-fiber count minimum) shall be coiled and stored unterminated at the terminal junction box.
- 3.5.3. Conduit, junction boxes and fiber-optic cable shall be in accordance with the appropriate section of this Scope of Work.

3.6. Conduit

- 3.6.1. Furnish and install four (4) 2-inch trunkline conduits (for communication) and all necessary hardware, including tracer wire and delineator markers by plowing, trenching, or directional drilling in accordance with Sections 1715 and 1733 of the 2018 NCDOT *Standard Specifications for Roads and Structures* for installing the fiber-optic

communications cable. Conduit shall not be placed in the median or under the roadway, except for lateral traverse crossings. Install a minimum of one (1) 2-inch conduit for drop cables from the trunkline to the ITS device.

- 3.6.2. Route the black and orange conduits into the ITS junction box. Route the white and blue conduit into the Tolls junction box.
- 3.6.3. Design and construct the conduit network to tie into the existing trunkline conduit at a junction box located near the existing CCTV-1 within the NC 55 Bypass interchange. Design and construct the conduit network to tie into the R-2721B trunkline conduit at a junction box east of the SR 1389 (Pierce Olive Road) crossing.
- 3.6.4. Furnish and install one (1) 2-inch conduit (for electrical service) and all necessary hardware by trenching or directional drilling in accordance with Section 1715 of the 2018 NCDOT *Standard Specifications for Roads and Structures* for installing the power service to the ITS devices. Conduit shall not be placed in the median or under the roadway, except for lateral traverse crossings. (Reference the Electrical Service Section below).
- 3.6.5. Upon completion of the conduit installation furnish the Engineer with Plan of Record documentation showing the horizontal and vertical locations of the installed conduits.

3.7. Delineator Markers

- 3.7.1. Furnish and install delineator markers with all necessary hardware in accordance with Sections 1098-13 and 1733 of the 2018 NCDOT *Standard Specifications for Roads and Structures*.
- 3.7.2. Place delineator markers at every fiber-optic splice and fiber-optic junction box location.
- 3.7.3. Provide text, including the NCTA contact number that is hot stamped in black on a yellow background material that will not fade or deteriorate over time. Provide delineator markers with a nominal message height of 15 inches and that contain the following text visible from all directions approaching the assembly:

**WARNING
NCTA FIBER-OPTIC CABLE
BEFORE EXCAVATING OR
IN AN EMERGENCY
CALL: (919) 825-2700**

- 3.7.4. Install delineator markers using a method that securely anchors the delineator marker in the ground to prohibit twisting and easy removal.

3.8. Junction Boxes

- 3.8.1. Furnish and install junction boxes (pull boxes) with all necessary hardware in accordance with Sections 1098-5 and 1716 of the 2018 NCDOT *Standard Specifications for Roads and Structures*. Provide special oversized junction boxes with minimum inside dimensions of 36"(l) x 24"(w) x 24"(d) where underground fiber-optic splice enclosures are to be installed.
- 3.8.2. Furnish and install junction boxes (pull boxes) with all necessary hardware in accordance with Sections 1098-5 and 1716 of the 2018 NCDOT *Standard Specifications for Roads and Structures*. Provide oversized junction boxes with minimum inside dimensions of 30"(l) x 15"(w) x 24"(d) for installing fiber-optic communications cable. Install junction boxes at maximum intervals of fifteen hundred (1500) feet.
- 3.8.3. Furnish and install junction boxes (pull boxes) with all necessary hardware in accordance with Sections 1098-5 and 1716 of the 2018 NCDOT *Standard Specifications for Roads and Structures*. Provide standard junction boxes with minimum inside dimensions of 16"(l) x 10"(w) x 10"(d) for electrical service. Install junction boxes at maximum intervals of three hundred (300) feet or at locations where underground splicing is necessary.
- 3.8.4. Furnish and install loop splice boxes with all necessary hardware in accordance with Sections 1098-5 and 1716 of the 2018 NCDOT *Standard Specifications for Roads and Structures*. Provide junction boxes with minimum inside dimensions of 36"(l) x 17"(w) x 30"(d) for splicing of toll system loops.
- 3.8.5. Provide larger (maximum inside dimensions of 48"(l) x 24"(w) x 24"(d)) custom junction boxes for specialized use near AET Toll Zones that meet or exceed the Tier 15 requirements of ANSI/SCTE 77. Provide certification that testing methods are compliant with ANSI/SCTE 77. Provide box drains for boxes at AET sites as shown in the [most recent version of the NCTA AET Standard Drawings dated May 31, 2018 provided by NCTA and posted to the R-2721A Connect site](#).
- 3.8.6. Provide an 18" reinforced concrete collar on all junction boxes, unless boxes are on slopes of 3:1 or worse. Avoid placing junction boxes on such slopes wherever possible.
- 3.8.7. Install loop splice boxes and custom junction boxes as detailed in the *NCTA AET Standard Drawings* ~~dated May 31, 2018~~.
- 3.8.8. Provide junction box covers with standard "NCTA Fiber-Optic Cable" or "Electric" logo, pull slots and stainless-steel pins.
- 3.8.9. Where ITS and toll fiber boxes are adjacent, mark the "Tolls" junction box with a blue plastic disc similarly in size and material to those used at other such boxes on NCTA facilities.

3.9. Fiber-Optic Cable / Drop Cable

Furnish and install two 144-single mode fiber-optic communications cable (one for ITS network, one for tolls network), drop cable assemblies, and all necessary hardware to all new ITS devices/locations within the project limits in accordance with Section 1098-10 of the 2018 NCDOT *Standard Specifications for Roads and Structures* and as per the *Complete 540 ITS and AET Concept Plans*. Furnish and install new 12-fiber drop cables to all device equipment cabinets installed by this project.

Provide 50 feet (minimum) fiber-optic cable as slack for each cable within each junction/pull box or splice box.

3.10. Fiber-Optic Splice Centers

3.10.1. Furnish and install fiber-optic splice enclosures and all necessary hardware where required to join fiber-optic cables. Comply with Section 1731 of the 2018 NCDOT *Standard Specifications for Roads and Structures*.

3.10.2. Modify existing splice enclosures impacted by the project if necessary. Obtain approval from NCDOT and/NCTA (as appropriate) prior to entering any existing splice enclosures.

3.10.3. Within enclosures, provide the necessary number of hinged mountable splice trays to store the number of splices required, plus the capacity to house twelve (12) additional splices. Provide a fiber containment basket for storage of loose buffer tubes that are expressed through the enclosure. Ensure enclosures allow sufficient space to prevent damage of the buffer tubes when coiled.

3.11. Electrical Service

Furnish and install new electrical services rated 200 Amps for underground service, 240/120 VAC service drops for the each new ITS device. No overhead electrical service will be allowed. Furnish and install related items of work, including, but not limited to standard-size junction boxes, combination panels, with all necessary hardware in accordance with Section 1700 of the 2018 NCDOT *Standard Specifications for Roads and Structures*. (Reference the Utilities Coordination Scope of Work found elsewhere in the RFP for additional coordination / approval requirements and payment responsibilities). Reference the *Electrical Service* Project Special Provision found elsewhere in this RFP. ITS devices in close proximity to AET toll zones should be powered by the electrical service at those toll zones.

Multiple ITS devices may share a common electrical service; however, devices without a dedicated meter generally will require a safety disconnect. ITS devices may not share an electrical service with a traffic signal.

3.12. Local Area Network

Install new local area network (LAN) equipment. Ethernet hub and edge switches will be furnished and configured by NCDOT. Reference the *Communication Hardware* Project Special Provision found elsewhere in this RFP. Conform to the NCDOT and NC Statewide IT Policies and Standards as described at <http://it.nc.gov/statewide-resources/policies>. The architecture of the IT modules must be approved by NCDOT IT and the NC Office of Information Technology architecture groups.

3.13. Other Codes and Standards

All ITS materials shall conform to the latest version of the applicable standards of the National Electrical Code (NEC), National Electric Manufacturer's Association (NEMA), the Underwriters' Laboratories, Inc. (UL), the Electronic Industries Association (EIA), the International Municipal Signal Association (IMSA), and the National Electrical Safety Code (NESC). All materials and workmanship must conform to the requirements of the NESC, standards of the American Society for Testing and Materials (ASTM); American National Standards Institute (ANSI). Comply with all federal laws, state laws, and city codes in accordance with the 2018 NCDOT *Standard Specifications for Roads and Structures*.

3.14. Submittals

The submittal of project plans, specifications for materials, catalog cuts, and installation and testing requirements shall be governed by the NCTA Design-Build Submittal Guidelines. No construction of the ITS devices and / or communications cable shall begin until the Department has accepted the 100% plans and specifications.

3.15. Qualified Products List

Submit a list of items on the NCDOT 2018 Qualified Products List (QPL) to receive approval for use on the project. Catalog cuts will not be required for items on the QPL. The QPL website is:

<https://connect.ncdot.gov/resources/safety/Pages/default.aspx>

4. MAINTENANCE, DOCUMENTATION, AND TESTING

4.1. Maintenance and Repair Requirements

The Design-Build Team shall maintain and repair all ITS components within the project scope, including but not limited to, ITS devices, ITS conduit system, and all related ITS components, from the beginning of construction until the final acceptance of the project by the NCDOT. After acceptance of the project, the Design-Build Team shall be responsible for repairing the system due to faulty materials or workmanship in accordance with the *Three Year Guarantee* Project Special Provision found elsewhere in this RFP, or longer if the Design-Build extends the aforementioned warranty period.

4.2. Plan of Record Documentation

Prepare and submit to the Department Plan of Record (POR) documentation that depicts the conduit and ITS device locations. Submit final POR documentation in electronic and hard copy format for Department approval. Provide electronic plans in MicroStation (latest release in use by the Department) format on CD. Submit hard copy documentation on 22 x 34-inch plan sheets. POR documentation shall include the final location and depth of conduits, wiring external to the cabinets, locations of splice enclosures, junction box locations, and SMFO cable terminations. Include in the POR documentation real world coordinates for all ITS devices, splice enclosures, junction boxes, and equipment cabinets installed or utilized under this project. Provide the coordinates in feet units using the North Carolina State Plane coordinate system (1983 North American Datum also known as NAD '83). Furnish coordinates that do not deviate more than 1.7 feet in the horizontal plane and 3.3 feet in the vertical plane. Global positioning system (GPS) equipment able to obtain the coordinate data within these tolerances may be used.

4.3. Testing

- 4.3.1. Develop test plans and procedures for the new DMS and all associated components and submit to the Engineer for review and approval. Upon completion of the DMS installations, conduct unit tests according to the approved test plan and procedures. Provide all necessary test equipment.
- 4.3.2. Test fiber-optic cable as per Section 1731 of the *Standard Specifications*.
- 4.3.3. Reference the *Testing & Acceptance* Project Special Provision found elsewhere in this RFP.
- 4.3.4. After successful completion of all unit tests, submit the test reports along with the record of repairs and part replacements to the Engineer. In case of failures and substandard performance, the Design-Build Team shall identify the cause, repair or replace the faulty parts and components and repeat the test. If the problem persists, the entire unit causing the problem shall be replaced prior to retest.

PUBLIC INVOLVEMENT AND INFORMATION SCOPE OF WORK

(10-18-18)

1. GENERAL SCOPE

The NCDOT will take the lead role on this project and be responsible for a portion of the public involvement and information efforts, through the Department's Public Involvement Group and Communications Office, respectively. At a minimum, the Design-Build Team shall designate a contact for public involvement and information inquiries / coordination

1.1. Project Coordination Meeting

The Design-Build Team shall hold an initial project coordination meeting with NCDOT at least six weeks prior to the start of construction to discuss project impacts to the public. This information will be used by the Department to create a Public Involvement and Information Plan.

1.2. Target Audiences

The Department will develop, with assistance from the Design-Build Team, the specific list of target audiences for this project. The following groups are identified as typical target audiences to receive informational materials:

- Governmental agencies
- Municipalities directly affected by construction
- Transportation services
- Emergency services
- Neighborhood groups and private homes
- Industry and businesses
- Chamber of Commerce
- Individual schools affected by the project
- County / City school systems
- Any other organization as deemed necessary by the Department.

1.3. Project Website

The Department will be responsible for establishing, creating, maintaining and updating a project website. However, throughout the project duration, the Design-Build Team shall coordinate public involvement activities with the NCDOT Public Involvement Officer assigned to the project; and provide weekly updates, photos and other needed announcements to the Communications Office to ensure the accuracy of the aforementioned project website.

2. PUBLIC INVOLVEMENT**2.1. NCDOT Responsibilities**

Unless noted otherwise elsewhere in this RFP, the NCDOT Public Involvement Group will be responsible for the activities noted below:

- Organizing public meetings, including venue selection, reservation and fee
- Excluding colored maps, developing and producing informational print materials for all meetings and workshops
- Soliciting and administering advertisements, as deemed necessary
- Mailings to the identified target audiences, including postage
- If necessary, developing and producing informational print materials for Limited English Proficiency (LEP) outreach
- Website updates related to public involvement efforts

2.2. Design-Build Team Responsibilities

- 2.2.1. To ensure that project information can be distributed to the public using standard methods, including but not limited to notices to newspapers, and to promote public awareness for the project, the Design-Build Team shall coordinate with the Public Involvement Officer assigned to the project.
- 2.2.2. The amount of public involvement required for this project shall be directly based on the Design-Build Team's Transportation Management Plans and construction details. The Design-Build Team's responsibilities shall include, but are not limited to, the following:
- Providing information requested by the Department to develop and produce informational printed materials for all meetings and workshops
 - Developing and providing colored maps for presentation at all public meetings / workshops
 - Providing details surrounding impacts to the public
 - Providing advance notice to the Department of upcoming project impacts
 - Assisting the Department in the development of the target audience list
 - Attending and / or speaking at public meetings
 - Hand delivery of time sensitive informational materials
- 2.2.3. The minimum public involvement requirements solely associated with the Transportation Management Plans shall include, but are not limited to the following:
- Public Meetings – If Beginning of Construction meeting for area businesses and residents is held, attending and / or speaking at this event.
 - Distribution of Informational Materials - For beginning of construction and for all road closures with detour routes, the Design-Build Team shall be responsible for providing time sensitive informational material, provided by the Department, directly to the target audiences. If the Design-Build Team informs the Department of the aforementioned activities less than twenty-one (21) calendar days in advance, the Design-Build Team shall hand deliver the materials to the impacted target audiences.
 - Meetings with local stakeholders – as needed but at least twice per year.

3. PUBLIC INFORMATION

- 3.1.1. Unless noted otherwise elsewhere in this RFP, the NCDOT Communications Office will be responsible for the activities noted below:
- Providing media announcements
 - Scheduling interviews, as needed
 - Website updates related to project progress
 - Social media updates on project progress
- 3.1.2. To ensure that project information can be distributed to the public using standard methods, including but not limited to notifying media outlets and updating the project website, the Design-Build Team shall inform the Department at least twenty-one (21) calendar days in advance of any construction activity that will significantly impact the public. These activities shall include, but are not limited to, the start of construction, major traffic shifts, road closures, ramp closures, detours, night work and project completion.
- 3.1.3. Throughout construction, the aforementioned Design-Build contact shall provide weekly updates to the NCDOT Communications Office, including, but not limited to, traffic control phasing, graphic illustrations, project pictures, etc.

AESTHETIC DESIGN SCOPE OF WORK

(12-14-18)

1. GENERAL**1.1. Consistency Throughout Project and With Existing Facility**

- 1.1.1. The Project shall include aesthetic treatments to roadway, bridge and other elements that are consistent with a combination of those used on the existing NC 147 and NC 540 toll routes. Therefore, the Design-Build Team shall provide an aesthetics package compliant with this scope of work and consistent with the *Complete 540 Aesthetic Design Guidelines* dated May 24, 2018 ("*Guidelines*"). In case of a conflict between this scope of work and the *Guidelines*, this scope of work shall govern.
- 1.1.2. The Design-Build Team shall consistently apply the design motif and replications of the aesthetics package throughout all of the proposed tolling areas, bridge abutments and bents, sign structures, ITS components and other roadway elements.
- 1.1.3. An exception to Sections 1.1.1 and 1.1.2 of this Scope of Work applies to the proposed eastbound NC 540 bridge over NC 55 Bypass. This bridge shall be designed with aesthetic treatments that match the existing adjacent westbound NC 540 bridge.

1.2. Complete 540 Aesthetic Design Guidelines

- 1.2.1. The Design-Build Team shall utilize the *Guidelines* to develop the designs, plans and details necessary for aesthetic treatments of bridges, roadways, and other elements as outlined herein.
- 1.2.2. The *Guidelines* are guidelines; however, they shall serve as the basis for retaining aesthetic treatment uniformity throughout the Triangle Expressway (Toll NC 540) corridor.
- 1.2.3. The *Guidelines* are hereby incorporated by reference into this Contract.
- 1.2.4. The NCTA will entertain variations of the aesthetic details contained in the *Guidelines*; provided, however, the Proposer brings any proposed variations to the NCTA's attention during the procurement process to ensure reasonable conformity to the *Guidelines* and to ascertain if an Alternative Technical Concept is required.

2. AESTHETIC DETAILS

At a minimum, the Design-Build Team shall adhere to the following:

2.1. Bridge Details

- 2.1.1. The bridge abutments shall be similar to the existing Triangle Expressway with enhanced end bents, cheek walls, MSE abutment walls and MSE turned-back retaining walls. However, except at NC 55 Bypass, the abutments and turned-back retaining walls shall be

faced with authentic full size (2"x8" nominal or 3"x11" nominal) clay brick. At NC 55 Bypass, these end bents and walls shall have a brick appearance on precast panels utilizing form liners and a concrete stain brick pattern as specified in the *Guidelines* or as otherwise directed by NCTA to match the existing abutment at this location.

- 2.1.2. Abutments shall include decorative pilasters, cheek walls, emblems and coping as described in the *Guidelines*. Any necessary pedestrian railings and fencing will match the existing Triangle Expressway. Walls shall be turned back as per the original details for the existing bridge and set forth by the *Guidelines*.
- 2.1.3. The full brick along the MSE turned-back retaining walls shall extend a minimum of 2 feet below the final grade.
- 2.1.4. Concrete girders are preferred for all bridges over any roadway. In the event that steel girders are used for these bridges, the steel shall be AASHTO M270 Grade 50 and painted in accordance with the 2018 *NCDOT Standard Specifications for Roads and Structures*. All steel girders on the Project shall be painted the same color as that specified for the concrete girders in the *Guidelines*.
- 2.1.5. These aesthetic treatments shall apply to those bridges specified in the *Structures Scope of Work*.
- 2.1.6. Barrier rail or parapet on the bridges shall extend to the end of the MSE turned-back retaining wall before transitioning to guardrail.
- 2.1.7. Bridge piers shall be approximately 36" wide and between 60" – 72" in length.

2.2. Noise Wall Details

- 2.2.1. All noise walls shall be constructed to include concrete caps, footings, pilasters, etc. as detailed in the *Guidelines*.
- 2.2.2. The Design-Build Team shall provide noise walls constructed with authentic full brick (2"x8" nominal or 3"x11" nominal) closely matching the brick used for the abutment and retaining walls, including the concrete details described in Section 2.2.1 above. Both faces of the noise walls shall be authentic full brick.
- 2.2.3. In the event that noise walls are required to be installed on bridges, the Design-Build Team shall include a wall type suitable for mounting on bridges and in a color that is complementary to the approach roadway noise walls.

2.3. Debossed Street Identification on Bridge Abutments

The back of barrier/MSE wall coping to be provided for the bridges shall contain the -Y- Line road name (or "Triangle Expressway" in locations where the -Y- line runs beneath the Triangle Expressway) in a different manner than currently provided to face oncoming traffic. A reverse mold casting or other accepted means shall be made to accurately create the new identification.

2.4. Columns

Columns for bridge interior bents, sign structures and toll gantries shall be similar to those found on the existing Triangle Expressway and detailed as shown in the *Guidelines*.

2.5. Dogwood Emblems

The proposed dogwood emblems at ends of interior bents and cheek walls shall match the existing emblems along the existing Triangle Expressway. The Design-Build Team shall replicate the emblem by reverse mold casting or other accepted means to accurately create the new emblems without the indication of attachment. Emblems at interior bents shall be placed on the exterior faces where multiple substructure units are used for a single bent line.

2.6. Barrier Reveals

All barriers reveals shall be detailed as shown in the *Guidelines* and adapted as necessary for the barrier height required for this Project. All rails seen by the traveling public shall be colored, including the back faces of the barrier that can be viewed from opposing traffic on NC 540. Painting on the side of the rail parallel to traffic will not be required.

2.7. Retaining Walls

2.7.1. All retaining walls visible to NC 540 traffic shall include full size (2"x8" nominal or 3"x11" nominal) real brick and be consistent with the *Guidelines*.

2.7.2. The brick of the retaining walls shall extend a minimum of 2 feet below the final grade.

2.8. Screen Walls

2.8.1. Decorative screen walls at toll system vaults shall include full size (2"x8" nominal or 3"x11" nominal) real brick consistent with the screen wall aesthetics illustrated in the *Guidelines*.

2.8.2. The brick of the screen walls shall extend upward from a visible, shallow, smooth-face concrete footer or panel as shown in the *Guidelines*.

2.9. Toll Gantries

Aesthetic treatments to the toll gantries shall be consistent through the Project and consistent with the *Guidelines*.

2.10. Anti-Graffiti Coating

The Design-Build Team shall apply anti-graffiti coating that is compatible with the noise walls. After application, the anti-graffiti coating shall be dry to the touch within one hour and shall achieve a final cure within three hours. The color of the anti-graffiti coating shall be clear after full cure. The Design-Build Team shall provide specifications for the anti-graffiti coating and one

gallon of graffiti remover, thinners, dryers and all necessary components recommended by the manufacturer to the North Carolina Department of Transportation Materials and Tests Unit, Chemical Testing Engineer.

The anti-graffiti coating shall be applied by brush, roller or airless spray when the ambient temperature is between 45° F and 90° F, and the surface temperature is between 50° F and 100° F or as required by the manufacturer. Ensure the surface is clean and dry before applying the anti-graffiti coating. The minimum dry film thickness of the anti-graffiti coating shall be 2.0 mils.

Anti-graffiti coating is also required on other elements as required by the *Structures Scope of Work*.

3. DESIGN REQUIREMENTS

The Design-Build Team shall ensure that the aesthetic details incorporated into the plans developed by the Design-Build Team will meet the appropriate engineering standards and the RFP requirements.

3.1. Preliminary Design

After the Contract has been executed, the Design-Build Team shall present, with appropriate visual aids, the aesthetic design intent, including but not limited to the aesthetic theme, the general plan, and the preliminary details for each design element within the Project. The NCTA will require 30 days to review this information to ensure that it is acceptable and consistent with or complementary to the existing Triangle Expressway corridor.

3.2. Final Design

- 3.2.1. The Design-Build Team shall include the accepted aesthetics details with the appropriate submittal of preliminary and final designs plans for each element (bridge, roadway, sign structure, gantry, etc.).
- 3.2.2. For each element, the Design-Build Team shall develop and submit for review and acceptance any specifications, material requirements and/or construction processes needed to accomplish the aesthetic work with the final design submittal.

3.3. Materials, Construction, and Fabrication

Three full size test panels will be required for each type of colored and/or textured concrete element on the Project including the dogwood emblems and embossed street identification. All coloring shall be supplied by a single commercial facility to avoid potential differences in tinting machines.

LIGHTING SCOPE OF WORK

(11-7-18)

1. GENERAL**1.1. Prequalification**

The Design-Build Team shall obtain the services of a firm prequalified for lighting design by the Department. The firm shall be prequalified prior to the Technical Proposal date.

1.2. Principle Standards

Provide lighting design in accordance with this Scope of Work, the *Lighting Project Special Provision* found elsewhere in this RFP. Furnish, install, connect, and place into satisfactory operating condition, lighting equipment and materials in accordance with Division 14 of the 2018 *NCDOT Standard Specifications for Roads and Structures*, and the 2018 *NCDOT Roadway Standard Drawings*, except as amended herein.

2. LIGHTING DESIGN**2.1. Lighting Locations**

Lighting shall be installed at the Holly Springs Road interchange. Lighting shall be provided for all acceleration lanes to the end of the taper, deceleration lanes to the end of the taper, toll zone parking areas, mainline lanes within the limits of the interchange, ramps, and loops, and ramp terminals. Lighting shall extend to the point where the controlled access crosses the -Y- line at the interchange.

Lighting under the bridge is required when the bridge width exceeds 100 feet.

2.2. Design Requirements

- 2.2.1. The lighting shall be designed to meet an AASHTO functional classification of Interstate and Other Freeways, with an average maintained foot-candle (fc) of 0.8 and Uniformity Ratio of 4:1 for all traveled lanes.
- 2.2.2. The Design-Build Team shall use a combination of high mast, single arm and twin arm poles in the lighting design. All single arm and twin arm poles shall be 45' in mounting height. High mast poles may range from 60' to 120' in height. Use the appropriate number of luminaires on each high mast pole to meet the minimum lighting design requirements. Furnish and install galvanized steel light standards and bracket arms similar in finish to those installed on the existing Triangle Expressway (excluding those installed at Veridea Parkway interchange – R-2635D).
- 2.2.3. All luminaires shall have light emitting diode (LED) light sources. See the *Lighting Special Provisions* for additional requirements.

2.3. Design Submittals

2.3.1. The Design-Build Team shall provide the following design information to the Department for review and acceptance prior to ordering lighting equipment:

- Electronic CADD files in MicroStation format, using Geopak Software (current version used by the Department), showing the proposed design.
- Photometric files in Visual Pro format showing light levels on the roadway.
- Files showing voltage drop calculations for conductor sizing of all lighting circuits.

2.3.2. The Design-Build Team shall allow ten days for Department review of each submittal for all materials including poles and foundation designs. An additional ten days shall be required for pole submittals from vendors that do not commonly do business with the Department.

3. ELECTRICAL SERVICE

Coordinate with the local utility company(ies), make application(s) in NCTA's name and pay all deposit fees to provide necessary electrical service. The Design-Build Team shall be responsible for all costs associated with providing electrical service for all lighting from the NCTA provided service taps. Refer to the Utilities Coordination Scope of Work for additional coordination requirements.

4. MAINTENANCE

Throughout construction, the Design-Build Team shall assume responsibility for routine maintenance of the newly installed lighting system(s) and any relocated lighting components in accordance with Division 14 of the 2018 NCDOT *Standard Specifications for Roads and Structures*, except as amended below.

- NCDOT will assume maintenance responsibility for the completed lighting systems after the project is accepted and there is no chance of construction-related damage.
- The Design-Build Team shall replace any newly installed non-functional lighting system components within the project limits. All luminaires must be operational at project acceptance.

***** STANDARD SPECIAL PROVISIONS *******PLANT AND PEST QUARANTINES****(Imported Fire Ant, Gypsy Moth, Witchweed, Emerald Ash Borer and Other Noxious Weeds)**

(8-31-13)(Rev. 12-20-16)

DB1 G130

Within Quarantined Area

This project may be within a county regulated for plant and / or pests. If the project or any part of the Design-Build Team's operations is located within a quarantined area, thoroughly clean all equipment prior to moving out of the quarantined area. Comply with federal / state regulations by obtaining a certificate or limited permit for any regulated article moving from the quarantined area.

Originating in a Quarantined County

Obtain a certificate or limited permit issued by the N.C. Department of Agriculture / United States Department of Agriculture. Have the certificate or limited permit accompany the article when it arrives at the project site.

Contact

Contact the N.C. Department of Agriculture / United States Department of Agriculture at 1-800-206-9333, 919-707-3730, or <http://www.ncagr.gov/plantindustry/> to determine those specific project sites located in the quarantined area or for any regulated article used on this project originating in a quarantined county.

Regulated Articles Include

1. Soil, sand, gravel, compost, peat, humus, muck, and decomposed manure, separately or with other articles. This includes movement of articles listed above that may be associated with cut / waste, ditch pulling, and shoulder cutting.
2. Plants with roots including grass sod
3. Plant crowns and roots
4. Bulbs, corms, rhizomes, and tubers of ornamental plants
5. Hay, straw, fodder, and plant litter of any kind
6. Clearing and grubbing debris
7. Used agricultural cultivating and harvesting equipment
8. Used earth-moving equipment
9. Any other products, articles, or means of conveyance, of any character, if determined by an inspector to present a hazard of spreading imported fire ant, gypsy moth, witchweed, emerald ash borer or other noxious weeds.

BRIDGE APPROACH FILLS

(10-19-10) (Rev. 11-22-17)

422

DB4 R02A

Description

Bridge approach fills consist of backfilling behind bridge end bents with select material or aggregate to support all or portions of bridge approach slabs. Install drains to drain water from bridge approach fills and geotextiles to separate approach fills from embankment fills, ABC and natural ground as required. For bridge approach fills behind end bents with mechanically stabilized earth (MSE) abutment walls, reinforce bridge approach fills with MSE wall reinforcement connected to end bent caps. Construct bridge approach fills in accordance with the contract, accepted submittals and 2018 Roadway Standard Drawing No. 422.01 or 422.02 or Roadway Detail Drawing No. 422D10.

Define bridge approach fill types as follows:

Approach Fills – Bridge approach fills in accordance with 2018 Roadway Standard Drawing No. 422.01, 2018 Roadway Standard Drawing No. 422.02 or Roadway Detail Drawing No. 422D10

Standard Approach Fill – Type I Standard Bridge Approach Fill in accordance with 2018 Roadway Standard Drawing No. 422.01

Modified Approach Fill – Type II Modified Bridge Approach Fill in accordance with 2018 Roadway Standard Drawing No. 422.02

Reinforced Approach Fill – Type III Reinforced Bridge Approach Fill in accordance with Roadway Detail Drawing No. 422D10

Materials

Refer to Division 10 of the 2018 *Standard Specifications for Roads and Structures*.

Item	Section
Geotextiles, Type 1	1056
Portland Cement Concrete	1000
Select Materials	1016
Subsurface Drainage Materials	1044

Provide Type 1 geotextile for separation geotextiles and Class B concrete for outlet pads. Use Class V or Class VI select material for standard and modified approach fills. For an approach fill behind a bridge end bent with an MSE abutment wall, backfill the reinforced approach fill with the same aggregate type approved for the reinforced zone in the accepted MSE wall submittal. For MSE wall aggregate, reinforcement and connector materials, see the *Mechanically Stabilized Earth Retaining Walls* provision. Provide PVC pipes, fittings and outlet pipes for subsurface drainage materials. For PVC drain pipes, use pipes with perforations that meet AASHTO M 278.

Construction Methods

Excavate as necessary for approach fills in accordance with the contract. Notify the Engineer when foundation excavation is complete. Do not place separation geotextiles or aggregate until approach fill dimensions and foundation material are approved.

For reinforced approach fills, cast MSE wall reinforcement or connectors into end bent cap backwalls within 3" of locations shown in the accepted MSE wall submittals. Install MSE wall reinforcement with the orientation, dimensions and number of layers shown in the accepted MSE wall submittals. If a reinforced approach fill is designed with geogrid reinforcement embedded in an end bent cap, cut geogrids to the required lengths and after securing ends of geogrids in place, reroll and rewrap portions of geogrids not embedded in the cap to protect geogrids from damage. Before placing aggregate, pull geosynthetic reinforcement taut so that it is in tension and free of kinks, folds, wrinkles or creases.

Attach separation geotextiles to end bent cap backwalls and wing walls with adhesives, tapes or other approved methods. Overlap adjacent separation geotextiles at least 18" with seams oriented parallel to the roadway centerline. Hold geotextiles in place with wire staples or anchor pins as needed. Contact the Engineer when existing or future obstructions such as foundations, pavements, pipes, inlets or utilities will interfere with separation geotextiles or MSE wall reinforcement.

Install continuous perforated PVC drain pipes with perforations pointing down in accordance with 2018 Roadway Standard Drawing No. 422.01 or 422.02. Connect drain pipes to outlet pipes just beyond wing walls. Connect PVC pipes, fittings and outlet pipes with solvent cement in accordance with Article 815-3 of the 2018 *Standard Specifications for Roads and Structures* and place outlet pads in accordance with 2018 Roadway Standard Drawing No. 815.03.

Install drain pipes so water drains towards outlets. If the groundwater elevation is above drain pipe elevations, raise drains up to maintain positive drainage towards outlets. Place pipe sleeves in or under wing walls so water drains towards outlets. Use sleeves that can withstand wing wall loads.

Place select material or aggregate in 8" to 10" thick lifts. Compact fine aggregate for reinforced approach fills in accordance with Subarticle 235-3(C) of the 2018 *Standard Specifications for Roads and Structures* except compact fine aggregate to a density of at least 98%. Compact select material for standard or modified approach fills and coarse aggregate for reinforced approach fills with a vibratory compactor to the satisfaction of the Engineer. Do not displace or damage geosynthetics, MSE wall reinforcement or drains when placing and compacting select material or aggregate. End dumping directly on geosynthetics is not permitted. Do not operate heavy equipment on geosynthetics or drain pipes until they are covered with at least 8" of select material or aggregate. Replace any damaged geosynthetics or drains to the satisfaction of the Engineer. When approach fills extend beyond bridge approach slabs, wrap separation geotextiles over select material or aggregate as shown in 2018 Roadway Standard Drawing No. 422.01 or Roadway Detail Drawing No. 422D10.

For temporary walls, use welded wire reinforcement for welded wire facing and Type 5 geotextile for reinforcement geotextiles. Use Type 5 geotextile with lengths and an ultimate tensile strength as shown in 2018 Roadway Standard Drawing No. 422.03. Provide Type 1 geotextile for separation geotextiles and Class B concrete for outlet pads. Use Class V or Class VI select material for alternate approach fills and temporary walls. Provide PVC pipes, fittings and outlet pipes for subsurface drainage materials. For PVC drain pipes, use pipes with perforations that meet AASHTO M 278.

ALTERNATE BRIDGE APPROACH FILLS FOR INTEGRAL ABUTMENTS

(11-21-17)

422

DB4 R02B

Description

At the Design-Build Team's option, use Type A Alternate Bridge Approach Fills instead of Type I or II Bridge Approach Fills to support bridge approach slabs for integral bridge abutments. An alternate bridge approach fill shall consist of constructing an approach fill with a temporary geotextile wall before placing all or a portion of the concrete for the backwall and wing walls of the integral end bent cap. The temporary geotextile wall shall be designed for a crane surcharge, shall remain in place and be aligned so the wall face functions as a form for the end bent cap backwall and wing walls. Install drains, welded wire facing and geotextiles and backfill approach fills and temporary walls with select material as required. Define "geotextiles" as separation or reinforcement geotextiles, "temporary wall" as a temporary geotextile wall and "alternate approach fill" as a Type A Alternate Bridge Approach Fill in accordance with 2018 Roadway Standard Drawing No. 422.03.

Materials

Refer to Division 10 of the 2018 *Standard Specifications for Roads and Structures*.

Item	Section
Geotextiles	1056
Portland Cement Concrete	1000
Select Materials	1016
Subsurface Drainage Materials	1044
Welded Wire Reinforcement	1070-3

For temporary walls, use welded wire reinforcement for welded wire facing and Type 5 geotextile for reinforcement geotextiles. Use Type 5 geotextile with lengths and an ultimate tensile strength as shown in 2018 Roadway Standard Drawing No. 422.03. Provide Type 1 geotextile for separation geotextiles and Class B concrete for outlet pads. Use Class V or Class VI select material for alternate approach fills and temporary walls. Provide PVC pipes, fittings and outlet pipes for subsurface drainage materials. For PVC drain pipes, use pipes with perforations that meet AASHTO M 278.

Construction Methods

Excavate as necessary for alternate approach fills and temporary walls in accordance with the

contract. Notify the Engineer when foundation excavation is complete. Do not place geotextiles until approach fill dimensions and foundation material are approved.

Install geotextiles as shown in 2018 Roadway Standard Drawing No. 422.03. Attach separation geotextiles to end bent cap backwalls and wing walls as needed with adhesives, tapes or other approved methods. Overlap adjacent geotextiles at least 18" with seams oriented parallel to the roadway centerline. Hold geotextiles in place with wire staples or anchor pins as needed. Contact the Engineer when existing or future obstructions such as foundations, pavements, pipes, inlets or utilities will interfere with geotextiles.

Install continuous perforated PVC drain pipes with perforations pointing down in accordance with 2018 Roadway Standard Drawing No. 422.03. Connect drain pipes to outlet pipes just beyond wing walls. Connect PVC pipes, fittings and outlet pipes with solvent cement in accordance with Article 815-3 of the 2018 *Standard Specifications for Roads and Structures* and place outlet pads in accordance with 2018 Roadway Standard Drawing No. 815.03.

Install drain pipes so water drains towards outlets. If the groundwater elevation is above drain pipe elevations, raise drains up to maintain positive drainage towards outlets. Place pipe sleeves in or under wing walls so water drains towards outlets. Use sleeves that can withstand wing wall loads.

At the Design-Build Team's option, construct bottom portion of integral end bents before temporary walls as shown in 2018 Roadway Standard Drawings No. 422.03. Erect and set welded wire facing so facing functions as a form for the end bent cap backwall. Place welded wire facing adjacent to each other in the horizontal and vertical directions to completely cover the temporary wall face. Stagger welded wire facing to create a running bond by centering facing over joints in the row below.

Wrap reinforcement geotextiles at the temporary wall face in accordance with 2018 Roadway Standard Drawing No. 422.03 and cover geotextiles with at least 3" of select material. Place layers of reinforcement geotextiles within 3" of locations shown in 2018 Roadway Standard Drawing No. 422.03. Before placing select material, pull reinforcement geotextiles taut so they are in tension and free of kinks, folds, wrinkles or creases. Install reinforcement geotextiles with the direction shown in 2018 Roadway Standard Drawing No. 422.03. Do not splice or overlap reinforcement geotextiles so seams are parallel to the temporary wall face.

Place select material in 8" to 10" thick lifts and compact select material with a vibratory compactor to the satisfaction of the Engineer. Do not displace or damage geotextiles or drains when placing and compacting select material. End dumping directly on geotextiles is not permitted. Do not operate heavy equipment on geotextiles or drain pipes until they are covered with at least 8" of select material. Replace any damaged geotextiles or drains to the satisfaction of the Engineer. When alternate approach fills extend beyond bridge approach slabs, wrap separation geotextiles over select material as shown in 2018 Roadway Standard Drawing No. 422.03.

Temporary walls shall be designed for a surcharge pressure in accordance with 2018 Roadway

Standard Drawing No. 422.03. If the crane surcharge will exceed the wall design, contact the Engineer before positioning the crane over reinforcement geotextiles.

ASPHALT CONCRETE PLANT MIX PAVEMENTS

(2-20-18)

610, 1012

DB6 R65

Revise the 2018 *Standard Specifications for Roads and Structures* as follows:

Page 6-17, Table 610-1, MIXING TEMPERATURE AT THE ASPHALT PLANT, replace with the following:

Binder Grade	JMF Temperature
PG 58-28; PG 64-22	250 - 290°F
PG 76-22	300 - 325°F

Page 6-17, Subarticle 610-3(C), Job Mix Formula (JMF), Lines 38 - 39, delete the fourth paragraph.

Page 6-18, Subarticle 610-3(C), Job Mix Formula (JMF), Line 12, replace “SF9.5A” with “S9.5B”.

Page 6-18, Table 610-3, MIX DESIGN CRITERIA, replace with the following:

Mix Type	Design ESALs millions ^A	Binder PG Grade ^B	Compaction Levels		Max. Rut Depth (mm)	Volumetric Properties				
			Gmm @			VMA	VTM	VFA	%Gmm	
			Nini	Ndes		% Min.	%	Min.-Max.	@ Nini	
S4.75A	< 1	64 - 22	6	50	11.5	16.0	4.0 - 6.0	65 - 80	≤ 91.5	
S9.5B	0 - 3	64 - 22	6	50	9.5	16.0	3.0 - 5.0	70 - 80	≤ 91.5	
S9.5C	3 - 30	64 - 22	7	65	6.5	15.5	3.0 - 5.0	65 - 78	≤ 90.5	
S9.5D	> 30	76 - 22	8	100	4.5	15.5	3.0 - 5.0	65 - 78	≤ 90.0	
I19.0C	ALL	64 - 22	7	65	-	13.5	3.0 - 5.0	65 - 78	≤ 90.5	
B25.0C	ALL	64 - 22	7	65	-	12.5	3.0 - 5.0	65 - 78	≤ 90.5	
			Design Parameter				Design Criteria			
All Mix Types			Dust to Binder Ratio ($P_{0.075} / P_{be}$)				0.6 - 1.4 ^C			
			Tensile Strength Ratio (TSR) ^D				85% Min. ^E			

A. Based on 20 year design traffic.

B. Volumetric Properties based on specimens compacted to N_{des} as modified by the Department.

C. Dust to Binder Ratio ($P_{0.075} / P_{be}$) for Type S4.75A is 1.0 - 2.0.

D. NCDOT-T-283 (No Freeze-Thaw cycle required).

E. TSR for Type S4.75A & B25.0C mixes is 80% minimum.

Page 6-19, Table 610-5, BINDER GRADE REQUIREMENTS (BASED ON RBR%), replace with the following:

Mix Type	%RBR ≤ 20%	21% ≤ %RBR ≤ 30%	%RBR > 30%
S4.75A, S9.5B, S9.5C, I19.0C, B25.0C	PG 64-22	PG 64-22 ^A	PG 58-28
S9.5D, OGFC	PG 76-22 ^B	n/a	n/a

- A. If the mix contains any amount of RAS, the virgin binder shall be PG 58-28.
 B. Maximum Recycled Binder Replacement (%RBR) is 18% for mixes using PG 76-22 binder.

Page 6-20, Table 610-6, PLACEMENT TEMPERATURES FOR ASPHALT, replace with the following:

Asphalt Concrete Mix Type	Minimum Surface and Air Temperature
B25.0C	35°F
I19.0C	35°F
S4.75A, S9.5B, S9.5C	40°F ^A
S9.5D	50°F

- A. For the final layer of surface mixes containing recycled asphalt mixes (RAS), the minimum surface and air temperature shall be 50°F.

Page 6-23, Table 610-7, DENSITY REQUIREMENTS, replace with the following:

Mix Type	Minimum % G _{mm} (Maximum Specific Gravity)
S4.75A	85.0 ^A
S9.5B	90.0
S9.5C, S9.5D, I19.0C, B25.0C	92.0

- A. Compaction to the above specified density will be required when the S4.75A mix is applied at a rate of 100 lbs/sy or higher.

Page 10-30, Table 1012-1, AGGREGATE CONSENSUS PROPERTIES, replace with the following:

Mix Type	Coarse Aggregate Angularity^B	Fine Aggregate Angularity % Minimum	Sand Equivalent % Minimum	Flat and Elongated 5 : 1 Ratio % Maximum
<i>Test Method</i>	<i>ASTM D5821</i>	<i>AASHTO T 304</i>	<i>AASHTO T 176</i>	<i>ASTM D4791</i>
S4.75A; S9.5B	75 / -	40	40	-
S9.5C; I19.0C; B25.0C	95 / 90	45	45	10
S9.5D	100 / 100	45	50	10
OGFC	100 / 100	45	45	10
UBWC	100 / 85	45	45	10

A. Requirements apply to the design aggregate blend.

B. 95 / 90 denotes that 95% of the coarse aggregate has one fractured face and 90% has 2 or more fractured faces.

SUBSURFACE DRAINAGE

(9-1-11) (Rev. 9-14-17)

DB8 R05

Revise the 2018 *Standard Specifications for Roads and Structures* as follows:

Page 8-11, Article 815-1, Delete the first sentence and replace with the following:

The Design-Build Team shall construct subsurface drains, underdrains, blind drains and other types of drains where groundwater is within six feet of subgrade.

GUARDRAIL END UNITS, TYPE TL-2

(10-21-08) (Rev. 9-14-17)

862

DB8 R64

Description

Furnish and install guardrail end units in accordance with the details in the plans developed by the Design-Build Team, the applicable requirements of Section 862 of the 2018 *Standard Specifications for Roads and Structures*, and at locations shown in the plans developed by the Design-Build Team.

Materials

The Design-Build Team shall furnish guardrail end units listed on the NCDOT Approved Products List at <https://apps.dot.state.nc.us/vendor/approvedproducts/> or approved equal.

Prior to installation, the Design-Build Team shall submit to the Engineer:

1. FHWA acceptance letter for each guardrail end unit certifying it meets the requirements of the AASHTO Manual for Assessing Safety Hardware, Test Level 2, in accordance with Article 106-2 of the 2018 *Standard Specifications for Roads and Structures*.
2. Certified working drawings and assembling instructions from the manufacturer for each guardrail end unit in accordance with Article 105-2 of the 2018 *Standard Specifications for Roads and Structures*.

No modifications shall be made to the guardrail end unit without the express written permission from the manufacturer. Perform installation in accordance with the details in the plans developed by the Design-Build Team, and details and assembling instructions furnished by the manufacturer.

Construction Methods

Guardrail end delineation shall be required on all approach and trailing end sections for both temporary and permanent installations. Guardrail end delineation shall consist of yellow reflective sheeting applied to the entire end section of the guardrail in accordance with Article 1088-3 of the 2018 *Standard Specifications for Roads and Structures*.

GUARDRAIL END UNITS, TYPE TL-3

(4-20-04) (Rev. 9-14-17)

862

DB8 R65

Description

Furnish and install guardrail end units in accordance with the details in the plans developed by the Design-Build Team, the applicable requirements of Section 862 of the 2018 *Standard Specifications for Roads and Structures*, and at locations shown in the plans developed by the Design-Build Team.

Materials

The Design-Build Team shall furnish guardrail end units listed on the NCDOT Approved Products List at <https://apps.dot.state.nc.us/vendor/approvedproducts/> or approved equal.

Prior to installation, the Design-Build Team shall submit to the Engineer:

1. FHWA acceptance letter for each guardrail end unit certifying it meets the requirements of the AASHTO Manual for Assessing Safety Hardware, Test Level 3, in accordance with Article 106-2 of the 2018 *Standard Specifications for Roads and Structures*.
2. Certified working drawings and assembling instructions from the manufacturer for each guardrail end unit in accordance with Article 105-2 of the 2018 *Standard Specifications for Roads and Structures*.

No modifications shall be made to the guardrail end unit without the express written permission from the manufacturer. Perform installation in accordance with the details in the plans developed by the Design-Build Team, and details and assembling instructions furnished by the manufacturer.

Construction Methods

Guardrail end delineation shall be required on all approach and trailing end sections for both temporary and permanent installations. Guardrail end delineation shall consist of yellow reflective sheeting applied to the entire end section of the guardrail in accordance with Article 1088-3 of the 2018 *Standard Specifications for Roads and Structures*.

GUARDRAIL ANCHOR UNITS AND TEMPORARY GUARDRAIL ANCHOR UNITS

(11-22-17)

862

DB8 R70

Guardrail anchor units shall be in accordance with the details in the plans developed by the Design-Build Team and the applicable requirements of Section 862 of the 2018 *Standard Specifications for Roads and Structures*.

IMPACT ATTENUATOR UNIT, TYPE TL-2

(4-11-07) (Rev. 9-5-18)

SPI 8-43

Description

Furnish and install impact attenuator units and any components necessary to connect the impact attenuators in accordance with the manufacturer's requirement, the details in the plans and at locations shown in the plans.

Materials

Furnish impact attenuator units listed on the [Approved Products List](https://apps.dot.state.nc.us/vendor/approvedproducts/) at <https://apps.dot.state.nc.us/vendor/approvedproducts/> or approved equal. Prior to installation the Contractor shall submit to the Engineer:

- (A) FHWA acceptance letter for each impact attenuator unit certifying it meets the requirements of the Manual for Assessing Safety Hardware (MASH-16), Test Level 2, in accordance with Article 106-2 of the *2018 Standard Specifications*.
- (B) Certified working drawings and assembling instructions from the manufacturer for each impact attenuator unit in accordance with Article 105-2 of the *2018 Standard Specifications*.

No modifications shall be made to the impact attenuator unit without the express written permission from the manufacturer. Perform installation in accordance with the details in the plans and details and assembling instructions furnished by the manufacturer.

Construction Methods

If the median width is 40 feet or less, the Contractor shall supply NON-GATING Impact Attenuator Units.

If the median width is greater than 40 feet, the Contractor may use GATING or NON-GATING Impact Attenuator Units.

IMPACT ATTENUATOR UNIT, TYPE TL-3

(4-20-04) (Rev. 9-5-18)

SP08 R075

Description

Furnish and install impact attenuator units and any components necessary to connect the impact attenuators in accordance with the manufacturer's requirement, the details in the plans and at locations shown in the plans.

Materials

Furnish impact attenuator units listed on the [Approved Products List](https://apps.dot.state.nc.us/vendor/approvedproducts/) at <https://apps.dot.state.nc.us/vendor/approvedproducts/> or approved equal. Prior to installation the Contractor shall submit to the Engineer:

- (A) FHWA acceptance letter for each impact attenuator unit certifying it meets the requirements of the Manual for Assessing Safety Hardware (MASH-16), Test Level 3, in accordance with Article 106-2 of the *2018 Standard Specifications*.
- (B) Certified working drawings and assembling instructions from the manufacturer for each impact attenuator unit in accordance with Article 105-2 of the *2018 Standard Specifications*.

No modifications shall be made to the impact attenuator unit without the express written permission from the manufacturer. Perform installation in accordance with the details in the plans and details and assembling instructions furnished by the manufacturer.

Construction Methods

If the median width is 40 feet or less, the Contractor shall supply NON-GATING Impact Attenuator Units.

If the median width is greater than 40 feet, the Contractor may use GATING or NON-GATING Impact Attenuator Units.

TEMPORARY SHORING

(2-20-07) (Rev. 9-15-17)

DB11 R02

Description

Temporary shoring includes cantilever, braced and anchored shoring and temporary mechanically stabilized earth (MSE) walls. Temporary shoring does not include trench boxes. At the Design-Build Team's option, use any type of temporary shoring, unless noted otherwise in the plans developed by the Design-Build Team or as directed.

Design and construct temporary shoring based on actual elevations and shoring dimensions in accordance with the plans developed by the Design-Build Team and accepted submittals. Construct temporary shoring at locations shown in the plans developed by the Design-Build Team and as directed. Temporary shoring shall be required to maintain traffic when a 2:1 (H:V) slope from the top of an embankment or bottom of an excavation will intersect the existing ground line less than five feet from the edge of pavement of an open travelway. This standard special provision does not apply to pipe, inlet or utility installation unless noted otherwise in the plans developed by the Design-Build Team.

Positive protection includes concrete barrier and temporary guardrail. Provide positive protection for temporary shoring at locations shown in the plans developed by the Design-Build Team and as directed. Positive protection shall be required if temporary shoring is located in the clear zone in accordance with the AASHTO *Roadside Design Guide*.

(A) Cantilever and Braced Shoring

Cantilever shoring consists of steel sheet piles or H-piles with timber lagging. Braced shoring consists of sheet piles or H-piles with timber lagging and bracing such as beams, plates, walers, struts, rakers, etc. Define "piles" as sheet piles or H-piles.

(B) Anchored Shoring

Anchored shoring consists of sheet piles with walers or H-piles with timber lagging anchored with ground or helical anchors. Driven anchors may be accepted at the discretion of the Engineer. A ground anchor consists of a grouted steel bar or multi-strand tendon with an anchorage. A helical anchor consists of a lead section with a central steel shaft and at least one helix steel plate followed by extensions with only central shafts (no helixes) and an anchorage. Anchorages consist of steel bearing plates with washers and hex nuts for bars or steel wedge plates and wedges for strands. Use a prequalified Anchored Wall Contractor to install ground anchors. Define "anchors" as ground, helical or driven anchors.

(C) Temporary MSE Walls

Temporary MSE walls include temporary geosynthetic and wire walls. Define "temporary wall" as a temporary MSE wall and "Temporary Wall Vendor" as the vendor

supplying the temporary MSE wall. Define “reinforcement” as geotextile, geogrid, welded wire grid or metallic strip reinforcement.

Temporary geosynthetic walls consist of geotextile or geogrid reinforcement wrapped behind welded wire facing. Define “temporary geotextile wall” as a temporary geosynthetic wall with geotextile reinforcement and “temporary geogrid wall” as a temporary geosynthetic wall with geogrid reinforcement.

Temporary wire walls consist of welded wire grid or metallic strip reinforcement connected to welded wire facing. Define “Wire Wall Vendor” as the vendor supplying the temporary wire wall.

(D) Embedment

Define “embedment” for cantilever, braced and anchored shoring as the pile depth below the grade in front of shoring. Define “embedment” for temporary walls as the wall height below the grade in front of walls.

(E) Positive Protection

Define “unanchored or anchored portable concrete barrier” as portable concrete barrier (PCB) that meets 2018 Roadway Standard Drawing No. 1170.01. Define “concrete barrier” as unanchored or anchored PCB or an approved equal. Define “temporary guardrail” as temporary steel beam guardrail that meets 2018 Roadway Standard Drawing No. 862.02.

Materials

Refer to the 2018 *Standard Specifications for Roads and Structures*.

Item	Section
Concrete Barrier Materials	1170-2
Flowable Fill, Excavatable	1000-6
Geosynthetics	1056
Neat Cement Grout	1003
Portland Cement Concrete	1000
Select Materials	1016
Steel Beam Guardrail Materials	862-2
Steel Plates	1072-2
Steel Sheet Piles and H-Piles	1084
Untreated Timber	1082-2
Welded Wire Reinforcement	1070-3

Provide Type 6 material certifications for shoring materials in accordance with Article 106-3 of the 2018 *Standard Specifications for Roads and Structures*. Use Class IV select material

(standard size No. ABC) for temporary guardrail. Use neat cement grout for Type 2 grout for ground anchors. Use Class A concrete that meets Article 450-2 of the 2018 *Standard Specifications for Roads and Structures* or Type 1 grout for drilled-in piles. Provide untreated timber with a thickness of at least 3" and a bending stress of at least 1,000 psi for timber lagging. Provide steel bracing that meets ASTM A36.

(A) Shoring Backfill

Use Class II, Type 1, Class III, Class V or Class VI select material or material that meets AASHTO M 145 for soil classification A-2-4 with a maximum PI of 6 for shoring backfill except do not use A-2-4 soil for backfill around culverts.

(B) Anchors

Store anchor materials on blocking a minimum of 12" above the ground and protect it at all times from damage; and when placing in the work make sure it is free from dirt, dust, loose mill scale, loose rust, paint, oil or other foreign materials. Load, transport, unload and store anchor materials so materials are kept clean and free of damage. Bent, damaged or defective materials shall be rejected.

(1) Ground Anchors

Use high-strength deformed steel bars that meet AASHTO M 275 or seven-wire strands that meet ASTM A886 or Article 1070-5 of the 2018 *Standard Specifications for Roads and Structures*. Splice bars in accordance with Article 1070-9 of the 2018 *Standard Specifications for Roads and Structures*. Do not splice strands. Use bondbreakers, spacers and centralizers that meet Article 6.3.5 of the AASHTO *LRFD Bridge Construction Specifications*.

(2) Helical Anchors

Use helical anchors with an ICC Evaluation Service, Inc. (ICC-ES) report. Provide couplers, thread bar adapters and bolts recommended by the Anchor Manufacturer to connect helical anchors together and to piles.

(3) Anchorages

Provide steel plates for bearing plates and steel washers, hex nuts, wedge plates and wedges recommended by the Anchor Manufacturer.

(C) Temporary Walls

(1) Welded Wire Facing

Use welded wire reinforcement for welded wire facing, struts and wires. For temporary wire walls, provide welded wire facing supplied by the Wire Wall

Vendor or a manufacturer approved or licensed by the vendor. For temporary wire walls with separate reinforcement and facing components, provide connectors (e.g., bars, clamps, plates, etc.) and fasteners (e.g., bolts, nuts, washers, etc.) required by the Wire Wall Vendor.

(2) Geotextiles

Provide Type 2 geotextile for separation and retention geotextiles. Provide Type 5 geotextile for geotextile reinforcement with ultimate tensile strengths in accordance with the accepted submittals.

(3) Geogrid Reinforcement

Use geogrids with a roll width of at least four feet and an “approved” or “approved for provisional use” status code. The list of approved geogrids is available from:

connect.ncdot.gov/resources/Materials/Pages/Materials-Manual-by-Material.aspx

Provide geogrids for geogrid reinforcement with design strengths in accordance with the accepted submittals. Geogrids are typically approved for ultimate tensile strengths in the machine direction (MD) and cross-machine direction (CD) or short-term design strengths for a three-year design life in the MD based on material type. Define material type from the website above for shoring backfill as follows:

Material Type	Shoring Backfill
Borrow	A-2-4 Soil
Fine Aggregate	Class II, Type 1 or Class III Select Material
Coarse Aggregate	Class V or VI Select Material

(4) Welded Wire Grid and Metallic Strip Reinforcement

Provide welded wire grid and metallic strip reinforcement supplied by the Wire Wall Vendor or a manufacturer approved or licensed by the vendor. Use welded wire grid reinforcement (“mesh”, “mats” and “ladders”) that meet Article 1070-3 of the 2018 *Standard Specifications for Roads and Structures* and metallic strip reinforcement (“straps”) that meet ASTM A572 or A1011.

Preconstruction Requirements

(A) Concrete Barrier

Define “clear distance” behind concrete barrier as the horizontal distance between the barrier and edge of pavement. The minimum required clear distance for concrete barrier

is shown in the plans developed by the Design-Build Team. At the Design-Build Team's option or if the minimum required clear distance is not available, set concrete barrier next to and up against traffic side of temporary shoring except for barrier above temporary walls. Concrete barrier with the minimum required clear distance shall be required above temporary walls.

(B) Temporary Guardrail

Define "clear distance" behind temporary guardrail as the horizontal distance between guardrail posts and temporary shoring. At the Design-Build Team's option or if clear distance for cantilever, braced and anchored shoring is less than four feet, attach guardrail to traffic side of shoring as shown in the plans developed by the Design-Build Team. Place ABC in clear distance and around guardrail posts instead of pavement. Do not use temporary guardrail above temporary walls.

(C) Temporary Shoring Designs

Before beginning temporary shoring design, survey existing ground elevations in the vicinity of shoring locations to determine actual design heights (H). Submit .pdf files of working drawings and design calculations for temporary shoring designs in accordance with Article 105-2 of the 2018 *Standard Specifications for Roads and Structures*. Submit working drawings showing plan views, shoring profiles, typical sections and details of temporary shoring design and construction sequence. Do not begin shoring construction until a design submittal is accepted.

Have cantilever and braced shoring designed, detailed and sealed by an engineer licensed in the state of North Carolina. Use a prequalified Anchored Wall Design Consultant to design anchored shoring. Provide anchored shoring designs sealed by a Design Engineer approved as a Geotechnical Engineer (key person) for an Anchored Wall Design Consultant. Include details in anchored shoring working drawings of anchor locations and lock-off loads, unit grout / ground bond strengths for ground anchors or minimum installation torque and torsional strength rating for helical anchors and if necessary, obstructions extending through shoring or interfering with anchors. Include details in the anchored shoring construction sequence of pile and anchor installation, excavation and anchor testing.

Provide temporary wall designs sealed by an Engineer licensed in the state of North Carolina and employed or contracted by the Temporary Wall Vendor. Include details in temporary wall working drawings of geotextile and reinforcement types, locations and directions and obstructions extending through walls or interfering with reinforcement.

(1) Soil Parameters

Design temporary shoring for the assumed soil parameters and groundwater elevations shown in the plans. Assume the following soil parameters for shoring backfill:

(a) Unit weight (γ) = 120 lb/cf;

(b)

Friction Angle (Φ)	Shoring Backfill
30°	A-2-4 Soil
34°	Class II, Type 1 or Class III Select Material
38°	Class V or VI Select Material

(c) Cohesion (c) = 0 lb/sf.

(2) Traffic Surcharge

Design temporary shoring for a traffic surcharge of 250 lb/sf if traffic will be above and within H of shoring. This traffic surcharge shall not apply to construction traffic. Design temporary shoring for any construction surcharge if construction traffic will be above and within H of shoring. For LRFD shoring designs, apply traffic (live load) surcharge in accordance with Figure C11.5.5-3 of the AASHTO *LRFD Bridge Design Specifications*.

(3) Cantilever, Braced and Anchored Shoring Designs

Use shoring backfill for fill sections and voids between cantilever, braced and anchored shoring and the critical failure surface. Use concrete or grout for embedded portions of drilled-in H-piles. Do not use drilled-in sheet piles.

Define “top of shoring” for cantilever, braced and anchored shoring as where the grade intersects the back of sheet piles or H-piles and timber lagging. Design cantilever, braced and anchored shoring for a traffic impact load of 2,000 lb/ft applied 18" above top of shoring if concrete barrier is above and next to shoring or temporary guardrail is above and attached to shoring. For anchored shoring designs, apply traffic impact load as horizontal load (P_{H1}) in accordance with Figure 3.11.6.3-2(a) of the AASHTO LRFD specifications.

Extend cantilever, braced and anchored shoring at least 32" above top of shoring if shoring is designed for traffic impact. Otherwise, extend shoring at least 6" above top of shoring.

Design cantilever, braced and anchored shoring for a maximum deflection of 3" if the horizontal distance to the closest edge of pavement or structure is less than H. Otherwise, design shoring for a maximum deflection of 6". Design cantilever and braced shoring in accordance with the plans developed by the Design-Build Team and AASHTO *Guide Design Specifications for Bridge Temporary Works*.

Design anchored shoring in accordance with the plans developed by the Design-Build Team and Article 11.9 of the AASHTO *LRFD Bridge Design Specifications*. Use a resistance factor of 0.80 for tensile resistance of anchors

with bars, strands or shafts. Extend the unbonded length for ground anchors and the shallowest helix for helical anchors at least five feet behind the critical failure surface. Do not extend anchors beyond right of way or easement limits. If existing or future obstructions such as foundations, guardrail posts, pavements, pipes, inlets or utilities will interfere with anchors, maintain a clearance of at least 6" between obstructions and anchors.

(4) Temporary Wall Designs

Use shoring backfill in the reinforced zone of temporary walls. Separation geotextiles are required between shoring backfill and backfill, natural ground or culverts along the sides of the reinforced zone perpendicular to the wall face. For Class V or VI select material in the reinforced zone, separation geotextiles are also required between shoring backfill and backfill or natural ground on top of and at the back of the reinforced zone.

Design temporary walls in accordance with the plans developed by the Design-Build Team and Article 11.10 of the *AASHTO LRFD Bridge Design Specifications*. Embed temporary walls at least 18" except for walls on structures or rock as determined by the Engineer. Use a uniform reinforcement length throughout the wall height of at least 0.7H or six feet, whichever is longer. Extend the reinforced zone at least 6" beyond end of reinforcement. Do not locate the reinforced zone outside right of way or easement limits.

Use the simplified method for determining maximum reinforcement loads in accordance with the AASHTO LRFD specifications. For geotextile reinforcement, use geotextile properties approved by the Department or default values in accordance with the AASHTO LRFD specifications. For geogrid reinforcement, use approved geogrid properties available from the website shown elsewhere in this provision. If the website does not list a short-term design strength for an approved geogrid, use a short-term design strength equal to the ultimate tensile strength divided by 3.5 for the geogrid reinforcement. Use geosynthetic properties for the direction reinforcement will be installed, a three-year design life and shoring backfill to be used in the reinforced zone.

Do not use more than four different reinforcement strengths for each temporary geosynthetic wall. Design temporary geotextile walls for a reinforcement coverage ratio (R_c) of 1.0. For temporary geogrid walls with an R_c of less than 1.0, use a maximum horizontal clearance between geogrids of three feet and stagger reinforcement so geogrids are centered over gaps in the reinforcement layer below.

For temporary geosynthetic walls, use "L" shaped welded wire facing with 18" to 24" long legs. Locate geotextile or geogrid reinforcement so reinforcement layers are at the same level as the horizontal legs of welded wire facing. Use vertical reinforcement spacing equal to facing height. Wrap geotextile or geogrid

reinforcement behind welded wire facing and extend reinforcement at least three feet back behind facing into shoring backfill.

For temporary wire walls with separate reinforcement and facing components, attach welded wire grid or metallic strip reinforcement to welded wire facing with a connection approved by the Department. For temporary geogrid and wire walls, retain shoring backfill at welded wire facing with retention geotextiles and extend geotextiles at least three feet back behind facing into backfill.

(D) Preconstruction Meeting

The Engineer may require a shoring preconstruction meeting to discuss the construction, inspection and testing of the temporary shoring. If required and if this meeting occurs before all shoring submittals have been accepted, additional preconstruction meetings may be required before beginning construction of temporary shoring without accepted submittals. The Resident, District or Bridge Maintenance Engineer, Bridge or Roadway Construction Engineer, Geotechnical Operations Engineer, Design-Build Team and Shoring Contractor Superintendent will attend preconstruction meetings.

Construction Methods

Control drainage during construction in the vicinity of shoring. Direct run off away from shoring and shoring backfill. Contain and maintain backfill and protect material from erosion.

Install positive protection in accordance with the contract and accepted submittals. Use PCB in accordance with Section 1170 of the 2018 *Standard Specifications for Roads and Structures* and 2018 Roadway Standard Drawing No. 1170.01. Use temporary guardrail in accordance with Section 862 of the 2018 *Standard Specifications for Roads and Structures* and 2018 Roadway Standard Drawing Nos. 862.01, 862.02 and 862.03.

(A) Tolerances

Construct shoring with the following tolerances:

- (1) Horizontal wires of welded wire facing are level in all directions,
- (2) Shoring location is within 6" of horizontal and vertical alignment shown in the accepted submittals, and
- (3) Shoring plumbness (batter) is not negative and within 2° of vertical.

(B) Cantilever, Braced and Anchored Shoring Installation

If overexcavation behind cantilever, braced or anchored shoring is shown in the accepted submittals, excavate before installing piles. Otherwise, install piles before excavating for shoring. Install cantilever, braced or anchored shoring in accordance with the

construction sequence shown in the accepted submittals. Remove piles and if applicable, timber lagging when shoring is no longer needed.

(1) Pile Installation

Install piles with the minimum required embedment and extension in accordance with Subarticles 450-3(D) and 450-3(E) of the 2018 *Standard Specifications for Roads and Structures* except that a pile driving equipment data form is not required. Piles may be installed with a vibratory hammer as approved by the Engineer.

Do not splice sheet piles. Use pile excavation to install drilled-in H-piles. After filling holes with concrete or grout to the elevations shown in the accepted submittals, remove any fluids and fill remaining portions of holes with flowable fill. Cure concrete or grout at least seven days before excavating.

Notify the Engineer if refusal is reached before pile excavation or driven piles attain the minimum required embedment. When this occurs, a revised design submittal may be required.

(2) Excavation

Excavate in front of piles from the top down in accordance with the accepted submittals. For H-piles with timber lagging and braced and anchored shoring, excavate in staged horizontal lifts with a maximum height of five feet. Remove flowable fill and material in between H-piles as needed to install timber lagging. Position lagging with at least 3" of contact in the horizontal direction between the lagging and pile flanges. Do not excavate the next lift until timber lagging for the current lift is installed and if applicable, bracing and anchors for the current lift are accepted. Backfill behind cantilever, braced or anchored shoring with shoring backfill.

(3) Anchor Installation

If applicable, install foundations located behind anchored shoring before installing anchors. Fabricate and install ground anchors in accordance with the accepted submittals, Articles 6.4 and 6.5 of the AASHTO *LRFD Bridge Construction Specifications* and the following unless otherwise approved:

- (a) Materials in accordance with this provision shall be required instead of materials conforming to Articles 6.4 and 6.5.3 of the AASHTO LRFD Specifications,
- (b) Encapsulation-protected ground anchors in accordance with Article 6.4.1.2 of the AASHTO LRFD specifications are not required, and

- (c) Corrosion protection for unbonded lengths of ground anchors and anchorage covers are not required.
- (d) Measure grout temperature, density and flow during grouting with at least the same frequency grout cubes are made for compressive strength. Perform density and flow field tests in the presence of the Engineer in accordance with American National Standards Institute / American Petroleum Institute Recommended Practice 13B-1 (Section 4, Mud Balance) and ASTM C939 (Flow Cone), respectively.

Install helical anchors in accordance with the accepted submittals and Anchor Manufacturer's instructions. Measure torque during installation and do not exceed the torsional strength rating of the helical anchor. Attain the minimum required installation torque and penetration before terminating anchor installation. When replacing a helical anchor, embed last helix of the replacement anchor at least 3 helix plate diameters past the location of the first helix of the previous anchor.

(4) Anchor Testing

Proof test and lock-off anchors in accordance with the accepted submittals and Article 6.5.5 of the AASHTO *LRFD Bridge Construction Specifications* except for the acceptance criteria in Article 6.5.5.5. For the AASHTO LRFD specifications, "ground anchor" refers to a ground or helical anchor and "tendon" refers to a bar, strand or shaft.

(a) Anchor Acceptance

Anchor acceptance is based in part on the following criteria.

- (i) For ground and helical anchors, total movement is less than 0.04" between the 1 and 10 minute readings or less than 0.08" between the 6 and 60 minute readings.
- (ii) For ground anchors, total movement at maximum test load exceeds 80% of the theoretical elastic elongation of the unbonded length.

(b) Anchor Test Results

Submit .pdf files of anchor test records including movement versus load plots for each load increment within 24 hours of completing each row of anchors. The Engineer will review the test records to determine if the anchors are acceptable.

If the Engineer determines an anchor is unacceptable, revise the anchor design or installation methods. Submit a revised anchored shoring design for acceptance and provide an acceptable anchor with the revised design

or installation methods. If required, replace the anchor or provide additional anchors with the revised design or installation methods.

(C) Temporary Wall Installation

Excavate as necessary for temporary walls in accordance with the plans developed by the Design-Build Team and accepted submittals. If applicable, install foundations located in the reinforced zone before placing shoring backfill or reinforcement unless otherwise approved. Notify the Engineer when foundation excavation is complete. Do not place shoring backfill or reinforcement until excavation dimensions and foundation material are approved.

Erect welded wire facing so the wall position is as shown in the plans developed by the Design-Build Team and accepted submittals. Set welded wire facing adjacent to each other in the horizontal and vertical direction to completely cover the wall face with facing. Stagger welded wire facing to create a running bond by centering facing over joints in the row below.

Wrap geotextile reinforcement and retention geotextiles behind welded wire facing as shown in the plans developed by the Design-Build Team and accepted submittals, and cover geotextiles with at least 3" of shoring backfill. Overlap adjacent geotextile reinforcement and retention and separation geotextiles at least 18" with seams oriented perpendicular to the wall face. Hold geotextiles in place with wire staples or anchor pins as needed.

Place reinforcement within 3" of locations shown in the plans developed by the Design-Build Team and accepted submittals. Before placing shoring backfill, pull reinforcement taut so it is in tension and free of kinks, folds, wrinkles or creases. Install reinforcement with the direction shown in the plans developed by the Design-Build Team and accepted submittals. For temporary wire walls with separate reinforcement and facing components, attach welded wire grid or metallic strip reinforcement to welded wire facing as shown in the accepted submittals. Do not splice or overlap reinforcement so seams are parallel to the wall face. Contact the Engineer when unanticipated existing or future obstructions such as foundations, pavements, pipes, inlets or utilities will interfere with reinforcement.

Place shoring backfill in the reinforced zone in 8" to 10" thick lifts. Compact A-2-4 soil and Class II, Type 1 and Class III select material in accordance with Subarticle 235-3(C) of the 2018 *Standard Specifications for Roads and Structures*. Use only hand operated compaction equipment to compact backfill within three feet of welded wire facing. At a distance greater than three feet, compact shoring backfill with at least four passes of an eight-ton to ten-ton vibratory roller in a direction parallel to the wall face. Smooth wheeled or rubber tired rollers are also acceptable for compacting backfill. Do not use sheepsfoot, grid rollers or other types of compaction equipment with feet. Do not displace or damage reinforcement when placing and compacting shoring backfill. End dumping directly on geotextile or geogrid reinforcement shall not be permitted. Do not operate

heavy equipment on reinforcement until it is covered with at least 8" of shoring backfill. Replace any damaged reinforcement to the satisfaction of the Engineer.

Backfill for temporary walls outside the reinforced zone in accordance with Article 410-8 of the 2018 *Standard Specifications for Roads and Structures*. Bench temporary walls into the sides of excavations where applicable. For temporary geosynthetic walls with top of wall within five feet of finished grade, remove top facing and incorporate top reinforcement layer into fill when placing fill in front of wall. Temporary walls remain in place permanently unless otherwise required.

ON-THE-JOB TRAINING

(2-24-15) (Rev. 7-20-17)

Z-10

Description

The North Carolina Department of Transportation will administer a custom version of the Federal On-the-Job Training (OJT) Program, commonly referred to as the Alternate OJT Program. All contractors (existing and newcomers) will be automatically placed in the Alternate Program. Standard OJT requirements typically associated with individual projects will no longer be applied at the project level. Instead, these requirements will be applicable on an annual basis for each contractor administered by the OJT Program Manager.

On the Job Training shall meet the requirements of 23 CFR 230.107 (b), 23 USC – Section 140, this provision and the On-the-Job Training Program Manual.

The Alternate OJT Program will allow a contractor to train employees on Federal, State and privately funded projects located in North Carolina. However, priority shall be given to training employees on NCDOT Federal-Aid funded projects.

Minorities and Women

Developing, training and upgrading of minorities and women toward journeyman level status is a primary objective of this special training provision. Accordingly, the Contractor shall make every effort to enroll minority and women as trainees to the extent that such persons are available within a reasonable area of recruitment. This training commitment is not intended, and shall not be used, to discriminate against any applicant for training, whether a member of a minority group or not.

Assigning Training Goals

The Department, through the OJT Program Manager, will assign training goals for a calendar year based on the contractors' past three years' activity and the contractors' anticipated upcoming year's activity with the Department. At the beginning of each year, all contractors eligible will be contacted by the Department to determine the number of trainees that will be assigned for the upcoming calendar year. At that time the Contractor shall enter into an agreement with the Department to provide a self-imposed on-the-job training program for the calendar year. This agreement will include a specific number of annual training goals agreed to by both parties.

The number of training assignments may range from 1 to 15 per contractor per calendar year. The Contractor shall sign an agreement to fulfill their annual goal for the year.

Training Classifications

The Contractor shall provide on-the-job training aimed at developing full journeyman level workers in the construction craft / operator positions. Preference shall be given to providing training in the following skilled work classifications:

Equipment Operators	Office Engineers
Truck Drivers	Estimators
Carpenters	Iron / Reinforcing Steel Workers
Concrete Finishers	Mechanics
Pipe Layers	Welders

The Department has established common training classifications and their respective training requirements that may be used by the contractors. However, the classifications established are not all-inclusive. Where the training is oriented toward construction applications, training will be allowed in lower-level management positions such as office engineers and estimators. Contractors shall submit new classifications for specific job functions that their employees are performing. The Department will review and recommend for acceptance to FHWA the new classifications proposed by contractors, if applicable. New classifications shall meet the following requirements:

Proposed training classifications are reasonable and realistic based on the job skill classification needs, and

The number of training hours specified in the training classification is consistent with common practices and provides enough time for the trainee to obtain journeyman level status.

The Contractor may allow trainees to be trained by a subcontractor provided that the Contractor retains primary responsibility for meeting the training and this provision is made applicable to the subcontract. However, only the Contractor will receive credit towards the annual goal for the trainee.

Where feasible, 25 percent of apprentices or trainees in each occupation shall be in their first year of apprenticeship or training. The number of trainees shall be distributed among the work classifications on the basis of the contractor's needs and the availability of journeymen in the various classifications within a reasonable area of recruitment.

No employee shall be employed as a trainee in any classification in which they have successfully completed a training course leading to journeyman level status or in which they have been employed as a journeyman.

Records and Reports

The Contractor shall maintain enrollment, monthly and completion reports documenting company compliance under these contract documents. These documents and any other information as requested shall be submitted to the OJT Program Manager.

Upon completion and graduation of the program, the Contractor shall provide each trainee with a certification Certificate showing the type and length of training satisfactorily completed.

Trainee Interviews

All trainees enrolled in the program will receive an initial and Trainee / Post graduate interview conducted by the OJT program staff.

Trainee Wages

Contractors shall compensate trainees on a graduating pay scale based upon a percentage of the prevailing minimum journeyman wages (Davis-Bacon Act). Minimum pay shall be as follows:

60 percent	of the journeyman wage for the first half of the training period
75 percent	of the journeyman wage for the third quarter of the training period
90 percent	of the journeyman wage for the last quarter of the training period

In no instance shall a trainee be paid less than the local minimum wage. The Contractor shall adhere to the minimum hourly wage rate that will satisfy both the NC Department of Labor (NCDOL) and the Department.

Achieving or Failing to Meet Training Goals

The Contractor will be credited for each trainee employed by him on the contract work who is currently enrolled or becomes enrolled in an approved program and who receives training for at least 50 percent of the specific program requirement. Trainees will be allowed to be transferred between projects if required by the Contractor's scheduled workload to meet training goals.

If a contractor fails to attain their training assignments for the calendar year, they may be taken off the NCDOT's Bidders List.

Measurement and Payment

No compensation will be made for providing required training in accordance with these contract documents.

STANDARD SPECIAL PROVISION**AVAILABILITY OF FUNDS – TERMINATION OF CONTRACTS**

(9-1-11)

Z-2

General Statute 143C-6-11. (h) Highway Appropriation is hereby incorporated verbatim in this contract as follows:

“(h) Amounts Encumbered – Transportation project appropriations may be encumbered in the amount of allotments made to the Department of Transportation by the Director for the estimated payments for transportation project contract work to be performed in the appropriation fiscal year. The allotments shall be multiyear allotments and shall be based on estimated revenues and shall be subject to the maximum contract authority contained in *General Statute 143C-6-11(c)*. Payment for transportation project work performed pursuant to contract in any fiscal year other than the current fiscal year is subject to appropriations by the General Assembly. Transportation project contracts shall contain a schedule of estimated completion progress, and any acceleration of this progress shall be subject to the approval of the Department of Transportation provided funds are available. The State reserves the right to terminate or suspend any transportation project contract, and any transportation project contract shall be so terminated or suspended if funds will not be available for payment of the work to be performed during that fiscal year pursuant to the contract. In the event of termination of any contract, the contractor shall be given a written notice of termination at least 60 days before completion of scheduled work for which funds are available. In the event of termination, the contractor shall be paid for the work already performed in accordance with the contract specifications.”

Payment will be made on any contract terminated pursuant to the special provision in accordance with Article 108-13(E), of the *North Carolina Department of Transportation Standard Specifications for Roads and Structures*, dated January 2018 and as amended by the Standard Special Provision, Division One found elsewhere in this RFP.

This provision applies equally to the North Carolina Turnpike Authority and this contract.

***** STANDARD SPECIAL PROVISIONS *******NCDOT GENERAL SEED SPECIFICATIONS FOR SEED QUALITY**

(5-7-11)

Z-3

Seed shall be sampled and tested by the North Carolina Department of Agriculture and Consumer Services, Seed Testing Laboratory. When said samples are collected, the vendor shall supply an independent laboratory report for each lot to be tested. Results from seed so sampled shall be final. Seed not meeting the specifications shall be rejected by the Department of Transportation and shall not be delivered to North Carolina Department of Transportation warehouses. If seed has been delivered it shall be available for pickup and replacement at the supplier's expense.

Any re-labeling required by the North Carolina Department of Agriculture and Consumer Services, Seed Testing Laboratory, that would cause the label to reflect as otherwise specified herein shall be rejected by the North Carolina Department of Transportation.

Seed shall be free from seeds of the noxious weeds Johnsongrass, Balloonvine, Jimsonweed, Witchweed, Itchgrass, Serrated Tussock, Showy Crotalaria, Smooth Crotalaria, Sicklepod, Sandbur, Wild Onion, and Wild Garlic. Seed shall not be labeled with the above weed species on the seed analysis label. Tolerances as applied by the Association of Official Seed Analysts will NOT be allowed for the above noxious weeds except for Wild Onion and Wild Garlic.

Tolerances established by the Association of Official Seed Analysts will generally be recognized. However, for the purpose of figuring pure live seed, the found pure seed and found germination percentages as reported by the North Carolina Department of Agriculture and Consumer Services, Seed Testing Laboratory will be used. Allowances, as established by the NCDOT, will be recognized for minimum pure live seed as listed on the following pages.

The specifications for restricted noxious weed seed refers to the number per pound as follows:

Restricted Noxious Weed	Limitations per Lb. of Seed	Restricted Noxious Weed	Limitations per Lb. of Seed
Blessed Thistle	4 seeds	Cornflower (Ragged Robin)	27 seeds
Cocklebur	4 seeds	Texas Panicum	27 seeds
Spurred Anoda	4 seeds	Bracted Plantain	54 seeds
Velvetleaf	4 seeds	Buckhorn Plantain	54 seeds
Morning-glory	8 seeds	Broadleaf Dock	54 seeds
Corn Cockle	10 seeds	Curly Dock	54 seeds
Wild Radish	12 seeds	Dodder	54 seeds
Purple Nutsedge	27 seeds	Giant Foxtail	54 seeds
Yellow Nutsedge	27 seeds	Horsenettle	54 seeds
Canada Thistle	27 seeds	Quackgrass	54 seeds
Field Bindweed	27 seeds	Wild Mustard	54 seeds
Hedge Bindweed	27 seeds		

Seed of Pensacola Bahiagrass shall not contain more than 7% inert matter, Kentucky Bluegrass, Centipede and Fine or Hard Fescue shall not contain more than 5% inert matter whereas a maximum of 2% inert matter will be allowed on all other kinds of seed. In addition, all seed shall not contain more than 2% other crop seed nor more than 1% total weed seed. The germination rate as tested by the North Carolina Department of Agriculture shall not fall below 70%, which includes both dormant and hard seed. Seed shall be labeled with not more than 7%, 5% or 2% inert matter (according to above specifications), 2% other crop seed and 1% total weed seed.

Exceptions may be made for minimum pure live seed allowances when cases of seed variety shortages are verified. Pure live seed percentages will be applied in a verified shortage situation. Those purchase orders of deficient seed lots will be credited with the percentage that the seed is deficient.

FURTHER SPECIFICATIONS FOR EACH SEED GROUP ARE GIVEN BELOW:

Minimum 85% pure live seed; maximum 1% total weed seed; maximum 2% total other crop seed; maximum 144 restricted noxious weed seed per pound. Seed less than 83% pure live seed will not be approved.

Sericea Lespedeza
Oats (seeds)

Minimum 80% pure live seed; maximum 1% total weed seed; maximum 2% total other crop; maximum 144 restricted noxious weed seed per pound. Seed less than 78% pure live seed will not be approved.

Tall Fescue (all approved varieties)	Bermudagrass
Kobe Lespedeza	Browntop Millet
Korean Lespedeza	German Millet - Strain R
Weeping Lovegrass	Clover – Red / White / Crimson
Carpetgrass	

Minimum 78% pure live seed; maximum 1% total weed seed; maximum 2% total other crop seed; maximum 144 restricted noxious weed seed per pound. Seed less than 76% pure live seed will not be approved.

Common or Sweet Sundangrass

Minimum 76% pure live seed; maximum 1% total weed seed; maximum 2% total other crop seed; maximum 144 restricted noxious weed seed per pound. Seed less than 74% pure live seed will not be approved.

Rye (grain; all varieties)
Kentucky Bluegrass (all approved varieties)
Hard Fescue (all approved varieties)
Shrub (bicolor) Lespedeza

Minimum 70% pure live seed; maximum 1% total weed seed; maximum 2% total other crop seed; maximum 144 noxious weed seed per pound. Seed less than 70% pure live seed will not be approved.

Centipede grass	Japanese Millet
Crownvetch	Reed Canary Grass
Pensacola Bahiagrass	Zoysia
Creeping Red Fescue	

Minimum 70% pure live seed; maximum 1% total weed seed; maximum 2% total other crop seed; maximum 5% inert matter; maximum 144 restricted noxious weed seed per pound.

Barnyard Grass
Big Bluestem
Little Bluestem
Bristly Locust
Birdsfoot Trefoil
Indiangrass
Orchardgrass
Switchgrass
Yellow Blossom Sweet Clover

TITLE VI AND NONDISCRIMINATION

(6-28-77)(Rev 5/2/18)

Z-6

Revise the 2018 *Standard Specifications for Roads and Structures* as follows:

Replace Article 103-4(B) with the following:

The North Carolina Department of Transportation is committed to carrying out the U.S. Department of Transportation's policy of ensuring nondiscrimination in the award and administration of contracts.

The provisions of this section related to United States Department of Transportation (US DOT) Order 1050.2A, Title 49 Code of Federal Regulations (CFR) part 21, 23 United States Code (U.S.C.) 140 and 23 CFR part 200 (or 49 CFR 303, 49 U.S.C. 5332 or 49 U.S.C. 47123) are applicable to all North Carolina Department of Transportation (NCDOT) contracts and to all related subcontracts, material supply, engineering, architectural and other service contracts, regardless of dollar amount. Any Federal provision that is specifically required not specifically set forth is hereby incorporated by reference.

(1) **Title VI Assurances (USDOT Order 1050.2A, Appendix A)**

During the performance of this contract, the contractor, for itself, its assignees, and successors in interest (hereinafter referred to as the "contractor") agrees as follows:

(a) **Compliance with Regulations**

The contractor (hereinafter includes consultants) shall comply with the Acts and the Regulations relative to Nondiscrimination in Federally-assisted programs of the U.S. Department of Transportation, Federal Highway Administration (FHWA), as they may be amended from time to time, which are herein incorporated by reference and made a part of this contract.

(b) **Nondiscrimination**

The contractor, with regard to the work performed by it during the contract, shall not discriminate on the grounds of race, color, or national origin in the selection and retention of subcontractors, including procurements of materials and leases of equipment. The contractor shall not participate directly or indirectly in the discrimination prohibited by the Acts and the Regulations, including employment practices when the contract covers any activity, project, or program set forth in Appendix B of 49 CFR Part 21.

(c) **Solicitations for Subcontractors, Including Procurements of Materials and Equipment**

In all solicitations, either by competitive bidding, or negotiation made by the contractor for work to be performed under a subcontract, including procurements of materials, or leases of equipment, each potential subcontractor or supplier shall be notified by the contractor of the contractor's obligations under this contract and the Acts and the Regulations relative to Nondiscrimination on the grounds of race, color, or national origin.

(d) Information and Reports

The contractor shall provide all information and reports required by the Acts, the Regulations, and directives issued pursuant thereto and shall permit access to its books, records, accounts, other sources of information, and its facilities as may be determined by the Recipient or the FHWA to be pertinent to ascertain compliance with such Acts, Regulations, and instructions. Where any information required of a contractor is in the exclusive possession of another who fails or refuses to furnish the information, the contractor shall so certify to the Recipient or the FHWA, as appropriate, and shall set forth what efforts it has made to obtain the information.

(e) Sanctions for Noncompliance:

In the event of a contractor's noncompliance with the Nondiscrimination provisions of this contract, the Recipient will impose such contract sanctions as it and / or the FHWA may determine to be appropriate, including, but not limited to:

- (i) Withholding payments to the contractor under the contract until the contractor complies; and / or
- (ii) Cancelling, terminating, or suspending a contract, in whole or in part.

(f) Incorporation of Provisions

The contractor shall include the provisions of paragraphs (a) through (6) in every subcontract, including procurements of materials and leases of equipment, unless exempt by the Acts, the Regulations and directives issued pursuant thereto. The contractor shall take action with respect to any subcontract or procurement as the Recipient or the FHWA may direct as a means of enforcing such provisions including sanctions for noncompliance. Provided, that if the contractor becomes involved in, or is threatened with litigation by a subcontractor, or supplier because of such direction, the contractor may request the Recipient to enter into any litigation to protect the interests of the Recipient. In addition, the contractor may request the United States to enter into the litigation to protect the interests of the United States.

(2) Title VI Nondiscrimination Program (23 CFR 200.5(p))

The North Carolina Department of Transportation (NCDOT) has assured the USDOT that, as a condition to receiving federal financial assistance, NCDOT will comply with Title VI of the Civil Rights Act of 1964 and all requirements imposed by Title 49 CFR Part 21 and related nondiscrimination authorities to ensure that no person shall, on the ground of race, color, national origin, limited English proficiency, sex, age, or disability (including religion / creed or income-level, where applicable), be excluded from participation in, be denied the benefits of, or be subjected to discrimination under any programs, activities, or services conducted or funded by NCDOT. Contractors and other organizations under contract or agreement with NCDOT must also comply with Title VI and related authorities, therefore:

- (a) During the performance of this contract or agreement, contractors (e.g. subcontractors, consultants, vendors, prime contractors) shall be responsible for

complying with NCDOT's Title VI Program. Contractors are not required to prepare or submit Title VI Programs. To comply with this section, the prime contractor shall:

1. Post NCDOT's Notice of Nondiscrimination and the Contractor's own Equal Employment Opportunity (EEO) Policy in conspicuous locations accessible to all employees, applicants and subcontractors on the jobsite.
 2. Physically incorporate the required Title VI clauses into all subcontracts on federally-assisted and state-funded NCDOT projects, and ensure inclusion by subcontractors into all lower-tier subcontracts.
 3. Required Solicitation Language. The Contractor shall include the following notification in all solicitations for bids and requests for work or material, regardless of funding source:

“The North Carolina Department of Transportation, in accordance with the provisions of Title VI of the Civil Rights Act of 1964 (78 Stat. 252, 42 US.C. §§ 2000d to 2000d-4) and the Regulations, hereby notifies all bidders that it will affirmatively ensure that any contract entered into pursuant to this advertisement, disadvantaged business enterprises will be afforded full and fair opportunity to submit bids in response to this invitation and will not be discriminated against on the grounds of race, color, or national origin in consideration for an award. In accordance with other related nondiscrimination authorities, bidders and contractors will also not be discriminated against on the grounds of sex, age, disability, low-income level, creed / religion, or limited English proficiency in consideration for an award.”
 4. Physically incorporate the FHWA-1273, in its entirety, into all subcontracts and subsequent lower tier subcontracts on Federal-aid highway construction contracts only.
 5. Provide language assistance services (i.e., written translation and oral interpretation), free of charge, to LEP employees and applicants. Contact NCDOT OCR for further assistance, if needed.
 6. For assistance with these Title VI requirements, contact the NCDOT Title VI Nondiscrimination Program at 1-800-522-0453.
- (b) Subrecipients (e.g. cities, counties, LGAs, planning organizations) may be required to prepare and submit a Title VI Plan to NCDOT, including Title VI Assurances and / or agreements. Subrecipients must also ensure compliance by their contractors and subrecipients with Title VI. (23 CFR 200.9(b)(7))
- (c) If reviewed or investigated by NCDOT, the contractor or subrecipient agrees to take affirmative action to correct any deficiencies found within a reasonable time period, not to exceed 90 calendar days, unless additional time is granted by NCDOT. (23 CFR 200.9(b)(15))

(d) The Contractor shall be responsible for notifying subcontractors of NCDOT's External Discrimination Complaints Process.

1. Applicability

Title VI and related laws protect participants and beneficiaries (e.g., members of the public and contractors) from discrimination by NCDOT employees, subrecipients and contractors, regardless of funding source.

2. Eligibility

Any person, or class of persons, who believes he / she has been subjected to discrimination based on race, color, national origin, Limited English Proficiency (LEP), sex, age, or disability (and religion in the context of employment, aviation, or transit) may file a written complaint. The law also prohibits intimidation or retaliation of any sort.

3. Time Limits and Filing Options

Complaints may be filed by the affected individual(s) or a representative and must be filed no later than 180 calendar days after the following:

- (i) The date of the alleged act of discrimination; or
- (ii) The date when the person(s) became aware of the alleged discrimination; or
- (iii) Where there has been a continuing course of conduct, the date on which that conduct was discontinued or the latest instance of the conduct.

Title VI and related discrimination complaints may be submitted to the following entities:

- North Carolina Department of Transportation, Office of Civil Rights, Title VI Program, 1511 Mail Service Center, Raleigh, NC 27699-1511; toll free 1-800-522-0453
- Federal Highway Administration, North Carolina Division Office, 310 New Bern Avenue, Suite 410, Raleigh, NC 27601; 919-747-7010
- US Department of Transportation, Departmental Office of Civil Rights, External Civil Rights Programs Division, 1200 New Jersey Avenue, SE, Washington, DC 20590; 202-366-4070

4. Format for Complaints

Complaints must be in writing and signed by the complainant(s) or a representative, and include the complainant's name, address, and telephone number. Complaints received by fax or e-mail will be acknowledged and processed. Allegations received by telephone will be reduced to writing and provided to the complainant for confirmation or revision before processing. Complaints will be accepted in other languages, including Braille.

5. Discrimination Complaint Form

Contact NCDOT Civil Rights to receive a full copy of the Discrimination Complaint Form and procedures.

6. Complaint Basis

Allegations must be based on issues involving race, color, national origin (LEP), sex, age, disability, or religion (in the context of employment, aviation or transit). “Basis” refers to the complainant’s membership in a protected group category.

TABLE 103-1 COMPLAINT BASIS			
Protected Categories	Definition	Examples	Applicable Nondiscrimination Authorities
Race and Ethnicity	An individual belonging to one of the accepted racial groups; or the perception, based usually on physical characteristics that a person is a member of a racial group	Black / African American, Hispanic / Latino, Asian, American Indian / Alaska Native, Native Hawaiian / Pacific Islander, White	Title VI of the Civil Rights Act of 1964; 49 CFR Part 21; 23 CFR 200; 49 U.S.C. 5332(b); 49 U.S.C. 47123. <i>(Executive Order 13166)</i>
Color	Color of skin, including shade of skin within a racial group	Black, White, Brown, Yellow, etc.	
National Origin <i>(Limited English Proficiency)</i>	Place of birth. Citizenship is not a factor. <i>(Discrimination based on language or a person’s accent is also covered)</i>	Mexican, Cuban, Japanese, Vietnamese, Chinese	
Sex	Gender. The sex of an individual. <i>Note: Sex under this program does not include sexual orientation.</i>	Women and Men	1973 Federal-Aid Highway Act; 49 U.S.C. 5332(b); 49 U.S.C. 47123.
Age	Persons of any age	21-year-old person	Age Discrimination Act of 1975 49 U.S.C. 5332(b); 49 U.S.C. 47123.
Disability	Physical or mental impairment, permanent or temporary, or perceived.	Blind, alcoholic, para-amputee, epileptic, diabetic, arthritic	Section 504 of the Rehabilitation Act of 1973; Americans with Disabilities Act of 1990
Religion (in the context of employment) <i>(Religion / Creed in all aspects of any aviation or transit-related construction)</i>	An individual belonging to a religious group; or the perception, based on distinguishable characteristics that a person is a member of a religious group. In practice, actions taken as a result of the moral and ethical beliefs as to what is right and wrong, which are sincerely held with the strength of traditional religious views. <i>Note: Does not have to be associated with a recognized religious group or church; if an individual sincerely holds to the belief, it is a protected religious practice.</i>	Muslim, Christian, Sikh, Hindu, etc.	Title VII of the Civil Rights Act of 1964; 23 CFR 230; FHWA-1273 Required Contract Provisions. <i>(49 U.S.C. 5332(b); 49 U.S.C. 47123)</i>

(3) Pertinent Nondiscrimination Authorities

During the performance of this contract, the contractor, for itself, its assignees, and successors in interest agrees to comply with the following non-discrimination statutes and authorities, including, but not limited to:

- Title VI of the Civil Rights Act of 1964 (42 U.S.C. § 2000d et seq., 78 stat. 252), (prohibits discrimination on the basis of race, color, national origin); and 49 CFR Part 21
- The Uniform Relocation Assistance and Real Property Acquisition Policies Act of 1970, (42 U.S.C. § 4601), (prohibits unfair treatment of persons displaced or whose property has been acquired because of Federal or Federal-aid programs and projects)
- Federal-Aid Highway Act of 1973, (23 U.S.C. § 324 et seq.), (prohibits discrimination on the basis of sex)
- Section 504 of the Rehabilitation Act of 1973, (29 U.S.C. § 794 et seq.), as amended, (prohibits discrimination on the basis of disability) and 49 CFR Part 27
- The Age Discrimination Act of 1975, as amended, (42 U.S.C. § 6101 et seq.), (prohibits discrimination on the basis of age)
- Airport and Airway Improvement Act of 1982, (49 USC § 471, Section 47123), as amended, (prohibits discrimination based on race, creed, color, national origin, or sex)
- (g) The Civil Rights Restoration Act of 1987, (PL 100-209), (Broadened the scope, coverage and applicability of Title VI of the Civil Rights Act of 1964, The Age Discrimination Act of 1975 and Section 504 of the Rehabilitation Act of 1973, by expanding the definition of the terms "programs or activities" to include all of the programs or activities of the Federal-aid recipients, sub-recipients and contractors, whether such programs or activities are Federally funded or not)
- (h) Titles II and III of the Americans with Disabilities Act, which prohibit discrimination on the basis of disability in the operation of public entities, public and private transportation systems, places of public accommodation, and certain testing entities (42 U.S.C. §§ 12131-12189) as implemented by Department of Transportation regulations at 49 C.F.R. parts 37 and 38
- (i) The Federal Aviation Administration's Nondiscrimination statute (49 U.S.C. § 47123) (prohibits discrimination on the basis of race, color, national origin, and sex)
- (j) Executive Order 12898, Federal Actions to Address Environmental Justice in Minority Populations and Low-Income Populations, which ensures Nondiscrimination against minority populations by discouraging programs, policies, and activities with disproportionately high and adverse human health or environmental effects on minority and low-income populations

- (k) Executive Order 13166, Improving Access to Services for Persons with Limited English Proficiency, and resulting agency guidance, national origin discrimination includes discrimination because of Limited English Proficiency (LEP). To ensure compliance with Title VI, you must take reasonable steps to ensure that LEP persons have meaningful access to your programs (70 Fed. Reg. at 74087 to 74100)
- (l) Title IX of the Education Amendments of 1972, as amended, which prohibits you from discriminating because of sex in education programs or activities (20 U.S.C. 1681 et seq)
- (m) Title VII of the Civil Rights Act of 1964 (42 U.S.C. § 2000e et seq., Pub. L. 88-352), (prohibits employment discrimination on the basis of race, color, religion, sex, or national origin).

(4) Additional Title VI Assurances

***The following Title VI Assurances (Appendices B, C and D) shall apply, as applicable*

(a) Clauses for Deeds Transferring United States Property (1050.2A, Appendix B)

The following clauses shall be included in deeds effecting or recording the transfer of real property, structures, or improvements thereon, or granting interest therein from the United States pursuant to the provisions of Assurance 4.

NOW, THEREFORE, the U.S. Department of Transportation as authorized by law and upon the condition that the North Carolina Department of Transportation (NCDOT) will accept title to the lands and maintain the project constructed thereon in accordance with the North Carolina General Assembly, the Regulations for the Administration of the Federal-Aid Highway Program, and the policies and procedures prescribed by the Federal Highway Administration of the U.S. Department of Transportation in accordance and in compliance with all requirements imposed by Title 49, Code of Federal Regulations, U.S. Department of Transportation, Subtitle A, Office of the Secretary, Part 21, Nondiscrimination in Federally-assisted programs of the U.S Department of Transportation pertaining to and effectuating the provisions of Title VI of the Civil Rights Act of 1964 (78 Stat. 252; 42 U.S.C. § 2000d to 2000d-4), does hereby remise, release, quitclaim and convey unto the NCDOT all the right, title and interest of the U.S. Department of Transportation in and to said lands described in Exhibit A attached hereto and made a part hereof.

(HABENDUM CLAUSE)

TO HAVE AND TO HOLD said lands and interests therein unto the North Carolina Department of Transportation (NCDOT) and its successors forever, subject, however, to the covenants, conditions, restrictions and reservations herein contained as follows, which will remain in effect for the period during which the real property or structures are used for a purpose for which Federal financial assistance is extended or for another purpose involving the provision of similar services or benefits and will be binding on the NCDOT, its successors and assigns.

The NCDOT, in consideration of the conveyance of said lands and interests in lands, does hereby covenant and agree as a covenant running with the land for itself, its successors and assigns, that (1) no person will on the grounds of race, color, or national origin, be excluded from participation in, be denied the benefits of, or be otherwise subjected to discrimination with regard to any facility located wholly or in part on, over, or under such lands hereby conveyed [,] [and]* (2) that the NCDOT will use the lands and interests in lands and interests in lands so conveyed, in compliance with all requirements imposed by or pursuant to Title 49, Code of Federal Regulations, U.S. Department of Transportation, Subtitle A, Office of the Secretary, Part 21, Non-discrimination in Federally-assisted programs of the U.S. Department of Transportation, Effectuation of Title VI of the Civil Rights Act of 1964, and as said Regulations and Acts may be amended [, and (3) that in the event of breach of any of the above-mentioned nondiscrimination conditions, the Department will have a right to enter or re-enter said lands and facilities on said land, and that above described land and facilities will thereon revert to and vest in and become the absolute property of the U.S. Department of Transportation and its assigns as such interest existed prior to this instruction].*

(*Reverter clause and related language to be used only when it is determined that such a clause is necessary in order to make clear the purpose of Title VI.)

(b) Clauses for Transfer of Real Property Acquired or Improved Under the Activity, Facility, or Program (1050.2A, Appendix C)

The following clauses shall be included in deeds, licenses, leases, permits, or similar instruments entered into by the North Carolina Department of Transportation (NCDOT) pursuant to the provisions of Assurance 7(a):

1. The (grantee, lessee, permittee, etc. as appropriate) for himself / herself, his / her heirs, personal representatives, successors in interest, and assigns, as a part of the consideration hereof, does hereby covenant and agree [in the case of deeds and leases add "as a covenant running with the land"] that:
 - (i.) In the event facilities are constructed, maintained, or otherwise operated on the property described in this (deed, license, lease, permit, etc.) for a purpose for which a U.S. Department of Transportation activity, facility, or program is extended or for another purpose involving the provision of similar services or benefits, the (grantee, licensee, lessee, permittee, etc.) will maintain and operate such facilities and services in compliance with all requirements imposed by the Acts and Regulations (as may be amended) such that no person on the grounds of race, color, or national origin, will be excluded from participation in, denied the benefits of, or be otherwise subjected to discrimination in the use of said facilities.

2. With respect to licenses, leases, permits, etc., in the event of breach of any of the above Nondiscrimination covenants, the NCDOT will have the right to terminate the (lease, license, permit, etc.) and to enter, re-enter, and repossess said lands and facilities thereon, and hold the same as if the (lease, license, permit, etc.) had never been made or issued. *
3. With respect to a deed, in the event of breach of any of the above Nondiscrimination covenants, the NCDOT will have the right to enter or re-enter the lands and facilities thereon, and the above described lands and facilities will there upon revert to and vest in and become the absolute property of the NCDOT and its assigns. *

(*Reverter clause and related language to be used only when it is determined that such a clause is necessary to make clear the purpose of Title VI.)

(c) Clauses for Construction / Use / Access to Real Property Acquired Under the Activity, Facility or Program (1050.2A, Appendix D)

The following clauses shall be included in deeds, licenses, permits, or similar instruments / agreements entered into by the North Carolina Department of Transportation (NCDOT) pursuant to the provisions of Assurance 7(b):

1. The (grantee, licensee, permittee, etc., as appropriate) for himself / herself, his / her heirs, personal representatives, successors in interest, and assigns, as a part of the consideration hereof, does hereby covenant and agree (in the case of deeds and leases add, "as a covenant running with the land") that (1) no person on the ground of race, color, or national origin, will be excluded from participation in, denied the benefits of, or be otherwise subjected to discrimination in the use of said facilities, (2) that in the construction of any improvements on, over, or under such land, and the furnishing of services thereon, no person on the ground of race, color, or national origin, will be excluded from participation in, denied the benefits of, or otherwise be subjected to discrimination, (3) that the (grantee, licensee, lessee, permittee, etc.) will use the premises in compliance with all other requirements imposed by or pursuant to the Acts and Regulations, as amended, set forth in this Assurance.
2. With respect to (licenses, leases, permits, etc.), in the event of breach of any of the above Nondiscrimination covenants, the NCDOT will have the right to terminate the (license, permit, etc., as appropriate) and to enter or re-enter and repossess said land and the facilities thereon, and hold the same as if said (license, permit, etc., as appropriate) had never been made or issued. *
3. With respect to deeds, in the event of breach of any of the above Nondiscrimination covenants, the NCDOT will there upon revert to and vest in and become the absolute property of the NCDOT and its assigns. *

(*Reverter clause and related language to be used only when it is determined that such a clause is necessary to make clear the purpose of Title VI.)

***** STANDARD SPECIAL PROVISIONS *******MINORITY AND FEMALE EMPLOYMENT REQUIREMENTS**

(12-18-07)

Z-7

NOTICE OF REQUIREMENTS FOR AFFIRMATIVE ACTION TO ENSURE EQUAL EMPLOYMENT OPPORTUNITY (*EXECUTIVE NUMBER 11246*)

1. The goals and timetables for minority and female participation, expressed in percentage terms for the Contractor's aggregate workforce in each trade on all construction work in the covered area, see as shown on the attached sheet entitled "Employment Goals for Minority and Female Participation".

These goals are applicable to all the Contractor's construction work (whether or not it is Federal or federally assisted) performed in the covered area. If the Contractor performs construction work in a geographical area located outside of the covered area, it shall apply the goals established for such geographical area where the work is actually performed. With regard to this second area, the Contractor also is subject to the goals for both its federally involved and nonfederally involved construction.

The Contractor's compliance with the Executive Order and the regulations in *41 CFR Part 60-4* shall be based on its implementation of the Equal Opportunity Clause, specific affirmative action obligations required by the specifications set forth in *41 CFR 60-4.3(a)*, and its effort to meet the goals. The hours of minority and female employment and training must be substantially uniform throughout the length of the contract, and in each trade and the Contractor shall make a good faith effort to employ minorities and women evenly on each of its projects. The transfer of minority or female employees or trainees from Contractor to Contractor or from project to project or the sole purpose of meeting the Contractor's goals shall be a violation of the contract, the executive Order and the regulations in *41 CFR Part 60-4*. Compliance with the goals will be measured against the total work hours performed.

2. As used in this Notice and in the contract resulting from this solicitation, the "covered area" is the county or counties shown on the cover sheet of the proposal form and contract.

**EMPLOYMENT GOALS FOR MINORITY
AND FEMALE PARTICIPATION**

Economic Areas

Area 023 29.7%

Bertie County
Camden County
Chowan County
Gates County
Hertford County
Pasquotank County
Perquimans County

Area 024 31.7%

Beaufort County
Carteret County
Craven County
Dare County
Edgecombe County
Green County
Halifax County
Hyde County
Jones County
Lenoir County
Martin County
Nash County
Northampton County
Pamlico County
Pitt County
Tyrrell County
Washington County
Wayne County
Wilson County

Area 025 23.5%

Columbus County
Duplin County
Onslow County
Pender County

Area 026 33.5%

Bladen County
Hoke County
Richmond County
Robeson County
Sampson County
Scotland County

Area 027 24.7%

Chatham County
Franklin County
Granville County
Harnett County
Johnston County
Lee County
Person County
Vance County
Warren County

Area 028 15.5%

Alleghany County
Ashe County
Caswell County
Davie County
Montgomery County
Moore County
Rockingham County
Surry County
Watauga County
Wilkes County

Area 029 15.7%

Alexander County
Anson County
Burke County
Cabarrus County
Caldwell County
Catawba County
Cleveland County
Iredell County
Lincoln County
Polk County
Rowan County
Rutherford County
Stanly County

Area 0480 8.5%

Buncombe County
Madison County

Area 030 6.3%

Avery County
Cherokee County
Clay County
Graham County
Haywood County
Henderson County
Jackson County
McDowell County
Macon County
Mitchell County
Swain County
Transylvania County
Yancey County

SMSA AreasArea 5720 26.6%

Currituck County

Area 9200 20.7%Brunswick County
New Hanover CountyArea 2560 24.2%

Cumberland County

Area 6640 22.8%Durham County
Orange County
Wake CountyArea 1300 16.2%

Alamance County

Area 3120 16.4%Davidson County
Forsyth County
Guilford County
Randolph County
Stokes County
Yadkin CountyArea 1520 18.3%Gaston County
Mecklenburg County
Union CountyGoals for FemaleParticipation in Each Trade

(Statewide) 6.9%

STANDARD SPECIAL PROVISION

REQUIRED CONTRACT PROVISIONS FEDERAL - AID CONSTRUCTION CONTRACTS

FHWA - 1273 Electronic Version - May 1, 2012

Z-8

- I. General
- II. Nondiscrimination
- III. Nonsegregated Facilities
- IV. Davis-Bacon and Related Act Provisions
- V. Contract Work Hours and Safety Standards Act Provisions
- VI. Subletting or Assigning the Contract
- VII. Safety: Accident Prevention
- VIII. False Statements Concerning Highway Projects
- IX. Implementation of Clean Air Act and Federal Water Pollution Control Act
- X. Compliance with Governmentwide Suspension and Debarment Requirements
- XI. Certification Regarding Use of Contract Funds for Lobbying

ATTACHMENTS

- A. Employment and Materials Preference for Appalachian Development Highway System or Appalachian Local Access Road Contracts (included in Appalachian contracts only)

I. GENERAL

1. Form FHWA-1273 must be physically incorporated in each construction contract funded under Title 23 (excluding emergency contracts solely intended for debris removal). The contractor (or subcontractor) must insert this form in each subcontract and further require its inclusion in all lower tier subcontracts (excluding purchase orders, rental agreements and other agreements for supplies or services).
The applicable requirements of Form FHWA-1273 are incorporated by reference for work done under any purchase order, rental agreement or agreement for other services. The prime contractor shall be responsible for compliance by any subcontractor, lower-tier subcontractor or service provider.
Form FHWA-1273 must be included in all Federal-aid design-build contracts, in all subcontracts and in lower tier subcontracts (excluding subcontracts for design services, purchase orders, rental agreements and other agreements for supplies or services). The design-builder shall be responsible for compliance by any subcontractor, lower-tier subcontractor or service provider.
Contracting agencies may reference Form FHWA-1273 in bid proposal or request for proposal documents, however, the Form FHWA-1273 must be physically incorporated (not referenced) in all contracts, subcontracts and lower-tier subcontracts (excluding purchase orders, rental agreements and other agreements for supplies or services related to a construction contract).
2. Subject to the applicability criteria noted in the following sections, these contract provisions shall apply to all work performed on the contract by the contractor's own organization and with the assistance of workers under the contractor's immediate superintendence and to all work performed on the contract by piecework, station work, or by subcontract.
3. A breach of any of the stipulations contained in these Required Contract Provisions may be sufficient grounds for withholding of progress payments, withholding of final payment, termination of the contract, suspension / debarment or any other action determined to be appropriate by the contracting agency and FHWA.
4. Selection of Labor: During the performance of this contract, the contractor shall not use convict labor for any purpose within the limits of a construction project on a Federal-aid highway unless it is labor performed by convicts who are on parole, supervised release, or probation. The term Federal-aid highway does not include roadways functionally classified as local roads or rural minor collectors.

II. NONDISCRIMINATION

The provisions of this section related to 23 CFR Part 230 are applicable to all Federal-aid construction contracts and to all related construction subcontracts of \$10,000 or more. The provisions of 23 CFR Part 230 are not applicable to material supply, engineering, or architectural service contracts.

In addition, the contractor and all subcontractors must comply with the following policies: Executive Order 11246, 41 CFR 60, 29 CFR 1625-1627, Title 23 USC Section 140, the Rehabilitation Act of 1973, as amended (29 USC 794), Title VI of the Civil Rights Act of 1964, as amended, and related regulations including 49 CFR Parts 21, 26 and 27; and 23 CFR Parts 200, 230, and 633.

The contractor and all subcontractors must comply with: the requirements of the Equal Opportunity Clause in 41 CFR 60-1.4(b) and, for all construction contracts exceeding \$10,000, the Standard Federal Equal Employment Opportunity Construction Contract Specifications in 41 CFR 60-4.3.

Note: The U.S. Department of Labor has exclusive authority to determine compliance with Executive Order 11246 and the policies of the Secretary of Labor including 41 CFR 60, and 29 CFR 1625-1627. The contracting agency and the FHWA have the authority and the responsibility to ensure compliance with Title 23 USC Section 140, the Rehabilitation Act of 1973, as amended (29 USC 794), and Title VI of the Civil Rights Act of 1964, as amended, and related regulations including 49 CFR Parts 21, 26 and 27; and 23 CFR Parts 200, 230, and 633.

The following provision is adopted from 23 CFR 230, Appendix A, with appropriate revisions to conform to the U.S. Department of Labor (US DOL) and FHWA requirements.

1. **Equal Employment Opportunity:** Equal employment opportunity (EEO) requirements not to discriminate and to take affirmative action to assure equal opportunity as set forth under laws, executive orders, rules, regulations (28 CFR 35, 29 CFR 1630, 29 CFR 1625-1627, 41 CFR 60 and 49 CFR 27) and orders of the Secretary of Labor as modified by the provisions prescribed herein, and imposed pursuant to 23 U.S.C. 140 shall constitute the EEO and specific affirmative action standards for the contractor's project activities under this contract. The provisions of the Americans with Disabilities Act of 1990 (42 U.S.C. 12101 et seq.) set forth under 28 CFR 35 and 29 CFR 1630 are

incorporated by reference in this contract. In the execution of this contract, the contractor agrees to comply with the following minimum specific requirement activities of EEO:

- a. The contractor will work with the contracting agency and the Federal Government to ensure that it has made every good faith effort to provide equal opportunity with respect to all of its terms and conditions of employment and in their review of activities under the contract.
- b. The contractor will accept as its operating policy the following statement:
"It is the policy of this Company to assure that applicants are employed, and that employees are treated during employment, without regard to their race, religion, sex, color, national origin, age or disability. Such action shall include: employment, upgrading, demotion, or transfer; recruitment or recruitment advertising; layoff or termination; rates of pay or other forms of compensation; and selection for training, including apprenticeship, pre-apprenticeship, and/or on-the-job training."
2. **EEO Officer:** The contractor will designate and make known to the contracting officers an EEO Officer who will have the responsibility for and must be capable of effectively administering and promoting an active EEO program and who must be assigned adequate authority and responsibility to do so.
3. **Dissemination of Policy:** All members of the contractor's staff who are authorized to hire, supervise, promote, and discharge employees, or who recommend such action, or who are substantially involved in such action, will be made fully cognizant of, and will implement, the contractor's EEO policy and contractual responsibilities to provide EEO in each grade and classification of employment. To ensure that the above agreement will be met, the following actions will be taken as a minimum:
 - a. Periodic meetings of supervisory and personnel office employees will be conducted before the start of work and then not less often than once every six months, at which time the contractor's EEO policy and its implementation will be reviewed and explained. The meetings will be conducted by the EEO Officer.
 - b. All new supervisory or personnel office employees will be given a thorough indoctrination by the EEO Officer, covering all major aspects of the contractor's EEO obligations within thirty days following their reporting for duty with the contractor.
 - c. All personnel who are engaged in direct recruitment for the project will be instructed by the EEO Officer in the contractor's procedures for locating and hiring minorities and women.
 - d. Notices and posters setting forth the contractor's EEO policy will be placed in areas readily accessible to employees, applicants for employment and potential employees.
 - e. The contractor's EEO policy and the procedures to implement such policy will be brought to the attention of employees by means of meetings, employee handbooks, or other appropriate means.
4. **Recruitment:** When advertising for employees, the contractor will include in all advertisements for employees the notation: "An Equal Opportunity Employer." All such advertisements will be placed in publications having a large circulation among minorities and women in the area from which the project work force would normally be derived.
 - a. The contractor will, unless precluded by a valid bargaining agreement, conduct systematic and direct recruitment through public and private employee referral sources likely to yield qualified minorities and women. To meet this requirement, the contractor will identify sources of potential minority group employees, and establish with such identified sources procedures whereby minority and women applicants may be referred to the contractor for employment consideration.
 - b. In the event the contractor has a valid bargaining agreement providing for exclusive hiring hall referrals, the contractor is expected to observe the provisions of that agreement to the extent that the system meets the contractor's compliance with EEO contract provisions. Where implementation of such an agreement has the effect of discriminating against minorities or women, or obligates the contractor to do the same, such implementation violates Federal nondiscrimination provisions.
 - c. The contractor will encourage its present employees to refer minorities and women as applicants for employment. Information and procedures with regard to referring such applicants will be discussed with employees.
5. **Personnel Actions:** Wages, working conditions, and employee benefits shall be established and administered, and personnel actions of every type, including hiring, upgrading, promotion, transfer, demotion, layoff, and termination, shall be taken without regard to race, color, religion, sex, national origin, age or disability. The following procedures shall be followed:
 - a. The contractor will conduct periodic inspections of project sites to insure that working conditions and employee facilities do not indicate discriminatory treatment of project site personnel.
 - b. The contractor will periodically evaluate the spread of wages paid within each classification to determine any evidence of discriminatory wage practices.
 - c. The contractor will periodically review selected personnel actions in depth to determine whether there is evidence of discrimination. Where evidence is found, the contractor will promptly take corrective action. If the review indicates that the discrimination may extend beyond the actions reviewed, such corrective action shall include all affected persons.
 - d. The contractor will promptly investigate all complaints of alleged discrimination made to the contractor in connection with its obligations under this contract, will attempt to resolve such complaints, and will take appropriate corrective action within a reasonable time. If the investigation indicates that the discrimination may affect persons other than the complainant, such corrective action shall include such other persons. Upon completion of each investigation, the contractor will inform every complainant of all of their avenues of appeal.
6. **Training and Promotion:**
 - a. The contractor will assist in locating, qualifying, and increasing the skills of minorities and women who are applicants for employment or current employees. Such efforts should be aimed at developing full journey level status employees in the type of trade or job classification involved.
 - b. Consistent with the contractor's work force requirements and as permissible under Federal and State regulations, the contractor shall make full use of training programs, i.e., apprenticeship, and on-the-job training programs for the geographical area of contract performance. In the event a special provision for training is provided under this contract, this subparagraph will be superseded as indicated in the special provision. The contracting agency may reserve training positions for persons who receive welfare assistance in accordance with 23 U.S.C. 140(a).
 - c. The contractor will advise employees and applicants for employment of available training programs and entrance requirements for each.
 - d. The contractor will periodically review the training and promotion potential of employees who are minorities and women and will encourage eligible employees to apply for such training and promotion.
7. **Unions:** If the contractor relies in whole or in part upon unions as a source of employees, the contractor will use good faith efforts to obtain the cooperation of such unions to increase opportunities for minorities and women. Actions by the contractor, either directly or through a contractor's association acting as agent, will include the procedures set forth below:

- a. The contractor will use good faith efforts to develop, in cooperation with the unions, joint training programs aimed toward qualifying more minorities and women for membership in the unions and increasing the skills of minorities and women so that they may qualify for higher paying employment.
 - b. The contractor will use good faith efforts to incorporate an EEO clause into each union agreement to the end that such union will be contractually bound to refer applicants without regard to their race, color, religion, sex, national origin, age or disability.
 - c. The contractor is to obtain information as to the referral practices and policies of the labor union except that to the extent such information is within the exclusive possession of the labor union and such labor union refuses to furnish such information to the contractor, the contractor shall so certify to the contracting agency and shall set forth what efforts have been made to obtain such information.
 - d. In the event the union is unable to provide the contractor with a reasonable flow of referrals within the time limit set forth in the collective bargaining agreement, the contractor will, through independent recruitment efforts, fill the employment vacancies without regard to race, color, religion, sex, national origin, age or disability; making full efforts to obtain qualified and/or qualifiable minorities and women. The failure of a union to provide sufficient referrals (even though it is obligated to provide exclusive referrals under the terms of a collective bargaining agreement) does not relieve the contractor from the requirements of this paragraph. In the event the union referral practice prevents the contractor from meeting the obligations pursuant to Executive Order 11246, as amended, and these special provisions, such contractor shall immediately notify the contracting agency.
8. **Reasonable Accommodation for Applicants / Employees with Disabilities:** The contractor must be familiar with the requirements for and comply with the Americans with Disabilities Act and all rules and regulations established there under. Employers must provide reasonable accommodation in all employment activities unless to do so would cause an undue hardship.
 9. **Selection of Subcontractors, Procurement of Materials and Leasing of Equipment:** The contractor shall not discriminate on the grounds of race, color, religion, sex, national origin, age or disability in the selection and retention of subcontractors, including procurement of materials and leases of equipment. The contractor shall take all necessary and reasonable steps to ensure nondiscrimination in the administration of this contract.
 - a. The contractor shall notify all potential subcontractors and suppliers and lessors of their EEO obligations under this contract.
 - b. The contractor will use good faith efforts to ensure subcontractor compliance with their EEO obligations.
 10. **Assurance Required by 49 CFR 26.13(b):**
 - a. The requirements of 49 CFR Part 26 and the State DOT's U.S. DOT-approved DBE program are incorporated by reference.
 - b. The contractor or subcontractor shall not discriminate on the basis of race, color, national origin, or sex in the performance of this contract. The contractor shall carry out applicable requirements of 49 CFR Part 26 in the award and administration of DOT-assisted contracts. Failure by the contractor to carry out these requirements is a material breach of this contract, which may result in the termination of this contract or such other remedy as the contracting agency deems appropriate.
 11. **Records and Reports:** The contractor shall keep such records as necessary to document compliance with the EEO requirements. Such records shall be retained for a period of three years following the date of the final payment to the contractor for all contract work and shall be available at reasonable times and places for inspection by authorized representatives of the contracting agency and the FHWA.
 - a. The records kept by the contractor shall document the following:
 - (1) The number and work hours of minority and non-minority group members and women employed in each work classification on the project;
 - (2) The progress and efforts being made in cooperation with unions, when applicable, to increase employment opportunities for minorities and women; and
 - (3) The progress and efforts being made in locating, hiring, training, qualifying, and upgrading minorities and women;
 - b. The contractors and subcontractors will submit an annual report to the contracting agency each July for the duration of the project, indicating the number of minority, women, and non-minority group employees currently engaged in each work classification required by the contract work. This information is to be reported on Form FHWA-1391. The staffing data should represent the project work force on board in all or any part of the last payroll period preceding the end of July. If on-the-job training is being required by special provision, the contractor will be required to collect and report training data. The employment data should reflect the work force on board during all or any part of the last payroll period preceding the end of July.

III. NONSEGREGATED FACILITIES

This provision is applicable to all Federal-aid construction contracts and to all related construction subcontracts of \$10,000 or more.

The contractor must ensure that facilities provided for employees are provided in such a manner that segregation on the basis of race, color, religion, sex, or national origin cannot result. The contractor may neither require such segregated use by written or oral policies nor tolerate such use by employee custom. The contractor's obligation extends further to ensure that its employees are not assigned to perform their services at any location, under the contractor's control, where the facilities are segregated. The term "facilities" includes waiting rooms, work areas, restaurants and other eating areas, time clocks, restrooms, washrooms, locker rooms, and other storage or dressing areas, parking lots, drinking fountains, recreation or entertainment areas, transportation, and housing provided for employees. The contractor shall provide separate or single-user restrooms and necessary dressing or sleeping areas to assure privacy between sexes.

IV. DAVIS-BACON AND RELATED ACT PROVISIONS

This section is applicable to all Federal-aid construction projects exceeding \$2,000 and to all related subcontracts and lower-tier subcontracts (regardless of subcontract size). The requirements apply to all projects located within the right-of-way of a roadway that is functionally classified as Federal-aid highway. This excludes roadways functionally classified as local roads or rural minor collectors, which are exempt. Contracting agencies may elect to apply these requirements to other projects.

The following provisions are from the U.S. Department of Labor regulations in 29 CFR 5.5 "Contract provisions and related matters" with minor revisions to conform to the FHWA-1273 format and FHWA program requirements.

1. Minimum wages

- a. All laborers and mechanics employed or working upon the site of the work, will be paid unconditionally and not less often than once a week, and without subsequent deduction or rebate on any account (except such payroll deductions as are permitted by regulations issued by the Secretary of Labor under the Copeland Act (29 CFR part 3)), the full amount of wages and bona fide fringe benefits (or cash equivalents thereof) due at time of payment computed at rates not less than those contained in the wage determination of the Secretary of Labor which is

attached hereto and made a part hereof, regardless of any contractual relationship which may be alleged to exist between the contractor and such laborers and mechanics.

Contributions made or costs reasonably anticipated for bona fide fringe benefits under section 1(b)(2) of the Davis-Bacon Act on behalf of laborers or mechanics are considered wages paid to such laborers or mechanics, subject to the provisions of paragraph 1.d. of this section; also, regular contributions made or costs incurred for more than a weekly period (but not less often than quarterly) under plans, funds, or programs which cover the particular weekly period, are deemed to be constructively made or incurred during such weekly period. Such laborers and mechanics shall be paid the appropriate wage rate and fringe benefits on the wage determination for the classification of work actually performed, without regard to skill, except as provided in 29 CFR 5.5(a)(4). Laborers or mechanics performing work in more than one classification may be compensated at the rate specified for each classification for the time actually worked therein: Provided, That the employer's payroll records accurately set forth the time spent in each classification in which work is performed. The wage determination (including any additional classification and wage rates conformed under paragraph 1.b. of this section) and the Davis-Bacon poster (WH-1321) shall be posted at all times by the contractor and its subcontractors at the site of the work in a prominent and accessible place where it can be easily seen by the workers.

- b. (1) The contracting officer shall require that any class of laborers or mechanics, including helpers, which is not listed in the wage determination and which is to be employed under the contract shall be classified in conformance with the wage determination. The contracting officer shall approve an additional classification and wage rate and fringe benefits therefore only when the following criteria have been met:
 - (i) The work to be performed by the classification requested is not performed by a classification in the wage determination; and
 - (ii) The classification is utilized in the area by the construction industry; and
 - (iii) The proposed wage rate, including any bona fide fringe benefits, bears a reasonable relationship to the wage rates contained in the wage determination.
 - (2) If the contractor and the laborers and mechanics to be employed in the classification (if known), or their representatives, and the contracting officer agree on the classification and wage rate (including the amount designated for fringe benefits where appropriate), a report of the action taken shall be sent by the contracting officer to the Administrator of the Wage and Hour Division, Employment Standards Administration, U.S. Department of Labor, Washington, DC 20210. The Administrator, or an authorized representative, will approve, modify, or disapprove every additional classification action within 30 days of receipt and so advise the contracting officer or will notify the contracting officer within the 30-day period that additional time is necessary.
 - (3) In the event the contractor, the laborers or mechanics to be employed in the classification or their representatives, and the contracting officer do not agree on the proposed classification and wage rate (including the amount designated for fringe benefits, where appropriate), the contracting officer shall refer the questions, including the views of all interested parties and the recommendation of the contracting officer, to the Wage and Hour Administrator for determination. The Wage and Hour Administrator, or an authorized representative, will issue a determination within 30 days of receipt and so advise the contracting officer or will notify the contracting officer within the 30-day period that additional time is necessary.
 - (4) The wage rate (including fringe benefits where appropriate) determined pursuant to paragraphs 1.b.(2) or 1.b.(3) of this section, shall be paid to all workers performing work in the classification under this contract from the first day on which work is performed in the classification.
- c. Whenever the minimum wage rate prescribed in the contract for a class of laborers or mechanics includes a fringe benefit which is not expressed as an hourly rate, the contractor shall either pay the benefit as stated in the wage determination or shall pay another bona fide fringe benefit or an hourly cash equivalent thereof.
 - d. If the contractor does not make payments to a trustee or other third person, the contractor may consider as part of the wages of any laborer or mechanic the amount of any costs reasonably anticipated in providing bona fide fringe benefits under a plan or program, Provided, That the Secretary of Labor has found, upon the written request of the contractor, that the applicable standards of the Davis-Bacon Act have been met. The Secretary of Labor may require the contractor to set aside in a separate account assets for the meeting of obligations under the plan or program.
2. **Withholding.** The contracting agency shall upon its own action or upon written request of an authorized representative of the Department of Labor, withhold or cause to be withheld from the contractor under this contract, or any other Federal contract with the same prime contractor, or any other federally-assisted contract subject to Davis-Bacon prevailing wage requirements, which is held by the same prime contractor, so much of the accrued payments or advances as may be considered necessary to pay laborers and mechanics, including apprentices, trainees, and helpers, employed by the contractor or any subcontractor the full amount of wages required by the contract. In the event of failure to pay any laborer or mechanic, including any apprentice, trainee, or helper, employed or working on the site of the work, all or part of the wages required by the contract, the contracting agency may, after written notice to the contractor, take such action as may be necessary to cause the suspension of any further payment, advance, or guarantee of funds until such violations have ceased.
 3. **Payrolls and basic records**
 - a. Payrolls and basic records relating thereto shall be maintained by the contractor during the course of the work and preserved for a period of three years thereafter for all laborers and mechanics working at the site of the work. Such records shall contain the name, address, and social security number of each such worker, his or her correct classification, hourly rates of wages paid (including rates of contributions or costs anticipated for bona fide fringe benefits or cash equivalents thereof of the types described in section 1(b)(2)(B) of the Davis-Bacon Act), daily and weekly number of hours worked, deductions made and actual wages paid. Whenever the Secretary of Labor has found under 29 CFR 5.5(a)(1)(iv) that the wages of any laborer or mechanic include the amount of any costs reasonably anticipated in providing benefits under a plan or program described in section 1(b)(2)(B) of the Davis-Bacon Act, the contractor shall maintain records which show that the commitment to provide such benefits is enforceable, that the plan or program is financially responsible, and that the plan or program has been communicated in writing to the laborers or mechanics affected, and records which show the costs anticipated or the actual cost incurred in providing such benefits. Contractors employing apprentices or trainees under approved programs shall maintain written evidence of the registration of apprenticeship programs and certification of trainee programs, the registration of the apprentices and trainees, and the ratios and wage rates prescribed in the applicable programs.
 - b. (1) The contractor shall submit weekly for each week in which any contract work is performed a copy of all payrolls to the contracting agency. The payrolls submitted shall set out accurately and completely all of the information required to be maintained under 29 CFR 5.5(a)(3)(i), except that full social security numbers and home addresses shall not be included on weekly transmittals. Instead the payrolls shall only need to include an individually identifying number for each employee (e.g. the last four digits of the employee's social security number). The required weekly payroll information may be submitted in any form desired. Optional Form WH-347 is available

for this purpose from the Wage and Hour Division Web site at <http://www.dol.gov/esa/whd/forms/wh347instr.htm> or its successor site. The prime contractor is responsible for the submission of copies of payrolls by all subcontractors. Contractors and subcontractors shall maintain the full social security number and current address of each covered worker, and shall provide them upon request to the contracting agency for transmission to the State DOT, the FHWA or the Wage and Hour Division of the Department of Labor for purposes of an investigation or audit of compliance with prevailing wage requirements. It is not a violation of this section for a prime contractor to require a subcontractor to provide addresses and social security numbers to the prime contractor for its own records, without weekly submission to the contracting agency.

- (2) Each payroll submitted shall be accompanied by a "Statement of Compliance," signed by the contractor or subcontractor or his or her agent who pays or supervises the payment of the persons employed under the contract and shall certify the following:
- (i) That the payroll for the payroll period contains the information required to be provided under §5.5 (a)(3)(ii) of Regulations, 29 CFR part 5, the appropriate information is being maintained under §5.5 (a)(3)(i) of Regulations, 29 CFR part 5, and that such information is correct and complete;
 - (ii) That each laborer or mechanic (including each helper, apprentice, and trainee) employed on the contract during the payroll period has been paid the full weekly wages earned, without rebate, either directly or indirectly, and that no deductions have been made either directly or indirectly from the full wages earned, other than permissible deductions as set forth in Regulations, 29 CFR part 3;
 - (iii) That each laborer or mechanic has been paid not less than the applicable wage rates and fringe benefits or cash equivalents for the classification of work performed, as specified in the applicable wage determination incorporated into the contract.
- (3) The weekly submission of a properly executed certification set forth on the reverse side of Optional Form WH-347 shall satisfy the requirement for submission of the "Statement of Compliance" required by paragraph 3.b.(2) of this section.
- (4) The falsification of any of the above certifications may subject the contractor or subcontractor to civil or criminal prosecution under section 1001 of title 18 and section 231 of title 31 of the United States Code.
- c. The contractor or subcontractor shall make the records required under paragraph 3.a. of this section available for inspection, copying, or transcription by authorized representatives of the contracting agency, the State DOT, the FHWA, or the Department of Labor, and shall permit such representatives to interview employees during working hours on the job. If the contractor or subcontractor fails to submit the required records or to make them available, the FHWA may, after written notice to the contractor, the contracting agency or the State DOT, take such action as may be necessary to cause the suspension of any further payment, advance, or guarantee of funds. Furthermore, failure to submit the required records upon request or to make such records available may be grounds for debarment action pursuant to 29 CFR 5.12.
4. **Apprentices and trainees**
- a. Apprentices (programs of the USDOL). Apprentices will be permitted to work at less than the predetermined rate for the work they performed when they are employed pursuant to and individually registered in a bona fide apprenticeship program registered with the U.S. Department of Labor, Employment and Training Administration, Office of Apprenticeship Training, Employer and Labor Services, or with a State Apprenticeship Agency recognized by the Office, or if a person is employed in his or her first 90 days of probationary employment as an apprentice in such an apprenticeship program, who is not individually registered in the program, but who has been certified by the Office of Apprenticeship Training, Employer and Labor Services or a State Apprenticeship Agency (where appropriate) to be eligible for probationary employment as an apprentice.

The allowable ratio of apprentices to journeymen on the job site in any craft classification shall not be greater than the ratio permitted to the contractor as to the entire work force under the registered program. Any worker listed on a payroll at an apprentice wage rate, who is not registered or otherwise employed as stated above, shall be paid not less than the applicable wage rate on the wage determination for the classification of work actually performed. In addition, any apprentice performing work on the job site in excess of the ratio permitted under the registered program shall be paid not less than the applicable wage rate on the wage determination for the work actually performed. Where a contractor is performing construction on a project in a locality other than that in which its program is registered, the ratios and wage rates (expressed in percentages of the journeyman's hourly rate) specified in the contractor's or subcontractor's registered program shall be observed.

Every apprentice must be paid at not less than the rate specified in the registered program for the apprentice's level of progress, expressed as a percentage of the journeymen hourly rate specified in the applicable wage determination. Apprentices shall be paid fringe benefits in accordance with the provisions of the apprenticeship program. If the apprenticeship program does not specify fringe benefits, apprentices must be paid the full amount of fringe benefits listed on the wage determination for the applicable classification. If the Administrator determines that a different practice prevails for the applicable apprentice classification, fringes shall be paid in accordance with that determination.

In the event the Office of Apprenticeship Training, Employer and Labor Services, or a State Apprenticeship Agency recognized by the Office, withdraws approval of an apprenticeship program, the contractor will no longer be permitted to utilize apprentices at less than the applicable predetermined rate for the work performed until an acceptable program is approved.

- b. Trainees (programs of the USDOL). Except as provided in 29 CFR 5.16, trainees will not be permitted to work at less than the predetermined rate for the work performed unless they are employed pursuant to and individually registered in a program which has received prior approval, evidenced by formal certification by the U.S. Department of Labor, Employment and Training Administration.

The ratio of trainees to journeymen on the job site shall not be greater than permitted under the plan approved by the Employment and Training Administration.

Every trainee must be paid at not less than the rate specified in the approved program for the trainee's level of progress, expressed as a percentage of the journeyman hourly rate specified in the applicable wage determination. Trainees shall be paid fringe benefits in accordance with the provisions of the trainee program. If the trainee program does not mention fringe benefits, trainees shall be paid the full amount of fringe benefits listed on the wage determination unless the Administrator of the Wage and Hour Division determines that there is an apprenticeship program associated with the corresponding journeyman wage rate on the wage determination which provides for less than full fringe benefits for apprentices. Any employee listed on the payroll at a trainee rate who is not registered and participating in a training plan approved by the Employment and Training Administration shall be paid not less than the applicable wage rate on the wage determination for the classification of work actually performed. In addition, any trainee performing work on the job site in excess of the ratio permitted under the registered program shall be paid not less than the applicable wage rate on the wage determination for the work actually performed.

In the event the Employment and Training Administration withdraws approval of a training program, the contractor will no longer be permitted to utilize trainees at less than the applicable predetermined rate for the work performed until an acceptable program is approved.

- c. Equal employment opportunity. The utilization of apprentices, trainees and journeymen under this part shall be in conformity with the equal employment opportunity requirements of Executive Order 11246, as amended, and 29 CFR part 30.
- d. Apprentices and Trainees (programs of the U.S. DOT). Apprentices and trainees working under apprenticeship and skill training programs which have been certified by the Secretary of Transportation as promoting EEO in connection with Federal-aid highway construction programs are not subject to the requirements of paragraph 4 of this Section IV. The straight time hourly wage rates for apprentices and trainees under such programs will be established by the particular programs. The ratio of apprentices and trainees to journeymen shall not be greater than permitted by the terms of the particular program.
- 5. **Compliance with Copeland Act requirements.** The contractor shall comply with the requirements of 29 CFR part 3, which are incorporated by reference in this contract.
- 6. **Subcontracts.** The contractor or subcontractor shall insert Form FHWA-1273 in any subcontracts and also require the subcontractors to include Form FHWA-1273 in any lower tier subcontracts. The prime contractor shall be responsible for the compliance by any subcontractor or lower tier subcontractor with all the contract clauses in 29 CFR 5.5.
- 7. **Contract termination:** debarment. A breach of the contract clauses in 29 CFR 5.5 may be grounds for termination of the contract, and for debarment as a contractor and a subcontractor as provided in 29 CFR 5.12.
- 8. **Compliance with Davis-Bacon and Related Act requirements.** All rulings and interpretations of the Davis-Bacon and Related Acts contained in 29 CFR parts 1, 3, and 5 are herein incorporated by reference in this contract.
- 9. **Disputes concerning labor standards.** Disputes arising out of the labor standards provisions of this contract shall not be subject to the general disputes clause of this contract. Such disputes shall be resolved in accordance with the procedures of the Department of Labor set forth in 29 CFR parts 5, 6, and 7. Disputes within the meaning of this clause include disputes between the contractor (or any of its subcontractors) and the contracting agency, the U.S. Department of Labor, or the employees or their representatives.
- 10. **Certification of eligibility.**
 - a. By entering into this contract, the contractor certifies that neither it (nor he or she) nor any person or firm who has an interest in the contractor's firm is a person or firm ineligible to be awarded Government contracts by virtue of section 3(a) of the Davis-Bacon Act or 29 CFR 5.12(a)(1).
 - b. No part of this contract shall be subcontracted to any person or firm ineligible for award of a Government contract by virtue of section 3(a) of the Davis-Bacon Act or 29 CFR 5.12(a)(1).
 - c. The penalty for making false statements is prescribed in the U.S. Criminal Code, 18 U.S.C. 1001.

V. CONTRACT WORK HOURS AND SAFETY STANDARDS ACT

The following clauses apply to any Federal-aid construction contract in an amount in excess of \$100,000 and subject to the overtime provisions of the Contract Work Hours and Safety Standards Act. These clauses shall be inserted in addition to the clauses required by 29 CFR 5.5(a) or 29 CFR 4.6. As used in this paragraph, the terms laborers and mechanics include watchmen and guards.

- 1. **Overtime requirements.** No contractor or subcontractor contracting for any part of the contract work which may require or involve the employment of laborers or mechanics shall require or permit any such laborer or mechanic in any workweek in which he or she is employed on such work to work in excess of forty hours in such workweek unless such laborer or mechanic receives compensation at a rate not less than one and one-half times the basic rate of pay for all hours worked in excess of forty hours in such workweek.
- 2. **Violation; liability for unpaid wages; liquidated damages.** In the event of any violation of the clause set forth in paragraph (1.) of this section, the contractor and any subcontractor responsible therefor shall be liable for the unpaid wages. In addition, such contractor and subcontractor shall be liable to the United States (in the case of work done under contract for the District of Columbia or a territory, to such District or to such territory), for liquidated damages. Such liquidated damages shall be computed with respect to each individual laborer or mechanic, including watchmen and guards, employed in violation of the clause set forth in paragraph (1.) of this section, in the sum of \$10 for each calendar day on which such individual was required or permitted to work in excess of the standard workweek of forty hours without payment of the overtime wages required by the clause set forth in paragraph (1.) of this section.
- 3. **Withholding for unpaid wages and liquidated damages.** The FHWA or the contracting agency shall upon its own action or upon written request of an authorized representative of the Department of Labor withhold or cause to be withheld, from any moneys payable on account of work performed by the contractor or subcontractor under any such contract or any other Federal contract with the same prime contractor, or any other federally-assisted contract subject to the Contract Work Hours and Safety Standards Act, which is held by the same prime contractor, such sums as may be determined to be necessary to satisfy any liabilities of such contractor or subcontractor for unpaid wages and liquidated damages as provided in the clause set forth in paragraph (2.) of this section.
- 4. **Subcontracts.** The contractor or subcontractor shall insert in any subcontracts the clauses set forth in paragraph (1.) through (4.) of this section and also a clause requiring the subcontractors to include these clauses in any lower tier subcontracts. The prime contractor shall be responsible for compliance by any subcontractor or lower tier subcontractor with the clauses set forth in paragraphs (1.) through (4.) of this section.

VI. SUBLETTING OR ASSIGNING THE CONTRACT

This provision is applicable to all Federal-aid construction contracts on the National Highway System.

- 1. The contractor shall perform with its own organization contract work amounting to not less than 30 percent (or a greater percentage if specified elsewhere in the contract) of the total original contract price, excluding any specialty items designated by the contracting agency. Specialty items may be performed by subcontract and the amount of any such specialty items performed may be deducted from the total original contract price before computing the amount of work required to be performed by the contractor's own organization (23 CFR 635.116).
 - a. The term "perform work with its own organization" refers to workers employed or leased by the prime contractor, and equipment owned or rented by the prime contractor, with or without operators. Such term does not include employees or equipment of a subcontractor or lower tier subcontractor, agents of the prime contractor, or any other assignees. The term may include payments for the costs of hiring leased employees from an employee leasing firm meeting all relevant Federal and State regulatory requirements. Leased employees may only be included in this term if the prime contractor meets all of the following conditions:
 - (1) the prime contractor maintains control over the supervision of the day-to-day activities of the leased employees;
 - (2) the prime contractor remains responsible for the quality of the work of the leased employees;
 - (3) the prime contractor retains all power to accept or exclude individual employees from work on the project; and

- (4) the prime contractor remains ultimately responsible for the payment of predetermined minimum wages, the submission of payrolls, statements of compliance and all other Federal regulatory requirements.
- b. "Specialty Items" shall be construed to be limited to work that requires highly specialized knowledge, abilities, or equipment not ordinarily available in the type of contracting organizations qualified and expected to bid or propose on the contract as a whole and in general are to be limited to minor components of the overall contract.
2. The contract amount upon which the requirements set forth in paragraph (1) of Section VI is computed includes the cost of material and manufactured products which are to be purchased or produced by the contractor under the contract provisions.
 3. The contractor shall furnish (a) a competent superintendent or supervisor who is employed by the firm, has full authority to direct performance of the work in accordance with the contract requirements, and is in charge of all construction operations (regardless of who performs the work) and (b) such other of its own organizational resources (supervision, management, and engineering services) as the contracting officer determines is necessary to assure the performance of the contract.
 4. No portion of the contract shall be sublet, assigned or otherwise disposed of except with the written consent of the contracting officer, or authorized representative, and such consent when given shall not be construed to relieve the contractor of any responsibility for the fulfillment of the contract. Written consent will be given only after the contracting agency has assured that each subcontract is evidenced in writing and that it contains all pertinent provisions and requirements of the prime contract.
 5. The 30% self-performance requirement of paragraph (1) is not applicable to design-build contracts; however, contracting agencies may establish their own self-performance requirements.

VII. SAFETY: ACCIDENT PREVENTION

This provision is applicable to all Federal-aid construction contracts and to all related subcontracts.

1. In the performance of this contract the contractor shall comply with all applicable Federal, State, and local laws governing safety, health, and sanitation (23 CFR 635). The contractor shall provide all safeguards, safety devices and protective equipment and take any other needed actions as it determines, or as the contracting officer may determine, to be reasonably necessary to protect the life and health of employees on the job and the safety of the public and to protect property in connection with the performance of the work covered by the contract.
2. It is a condition of this contract, and shall be made a condition of each subcontract, which the contractor enters into pursuant to this contract, that the contractor and any subcontractor shall not permit any employee, in performance of the contract, to work in surroundings or under conditions which are unsanitary, hazardous or dangerous to his/her health or safety, as determined under construction safety and health standards (29 CFR 1926) promulgated by the Secretary of Labor, in accordance with Section 107 of the Contract Work Hours and Safety Standards Act (40 U.S.C. 3704).
3. Pursuant to 29 CFR 1926.3, it is a condition of this contract that the Secretary of Labor or authorized representative thereof, shall have right of entry to any site of contract performance to inspect or investigate the matter of compliance with the construction safety and health standards and to carry out the duties of the Secretary under Section 107 of the Contract Work Hours and Safety Standards Act (40 U.S.C.3704).

VIII. FALSE STATEMENTS CONCERNING HIGHWAY PROJECTS

This provision is applicable to all Federal-aid construction contracts and to all related subcontracts.

In order to assure high quality and durable construction in conformity with approved plans and specifications and a high degree of reliability on statements and representations made by engineers, contractors, suppliers, and workers on Federal-aid highway projects, it is essential that all persons concerned with the project perform their functions as carefully, thoroughly, and honestly as possible. Willful falsification, distortion, or misrepresentation with respect to any facts related to the project is a violation of Federal law. To prevent any misunderstanding regarding the seriousness of these and similar acts, Form FHWA-1022 shall be posted on each Federal-aid highway project (23 CFR 635) in one or more places where it is readily available to all persons concerned with the project:

18 U.S.C. 1020 reads as follows:

"Whoever, being an officer, agent, or employee of the United States, or of any State or Territory, or whoever, whether a person, association, firm, or corporation, knowingly makes any false statement, false representation, or false report as to the character, quality, quantity, or cost of the material used or to be used, or the quantity or quality of the work performed or to be performed, or the cost thereof in connection with the submission of plans, maps, specifications, contracts, or costs of construction on any highway or related project submitted for approval to the Secretary of Transportation; or

Whoever knowingly makes any false statement, false representation, false report or false claim with respect to the character, quality, quantity, or cost of any work performed or to be performed, or materials furnished or to be furnished, in connection with the construction of any highway or related project approved by the Secretary of Transportation; or

Whoever knowingly makes any false statement or false representation as to material fact in any statement, certificate, or report submitted pursuant to provisions of the Federal-aid Roads Act approved July 1, 1916, (39 Stat. 355), as amended and supplemented;

Shall be fined under this title or imprisoned not more than 5 years or both."

IX. IMPLEMENTATION OF CLEAN AIR ACT AND FEDERAL WATER POLLUTION CONTROL ACT

This provision is applicable to all Federal-aid construction contracts and to all related subcontracts.

By submission of this bid/proposal or the execution of this contract, or subcontract, as appropriate, the bidder, proposer, Federal-aid construction contractor, or subcontractor, as appropriate, will be deemed to have stipulated as follows:

1. That any person who is or will be utilized in the performance of this contract is not prohibited from receiving an award due to a violation of Section 508 of the Clean Water Act or Section 306 of the Clean Air Act.
2. That the contractor agrees to include or cause to be included the requirements of paragraph (1) of this Section X in every subcontract, and further agrees to take such action as the contracting agency may direct as a means of enforcing such requirements.

X. CERTIFICATION REGARDING DEBARMENT, SUSPENSION, INELIGIBILITY AND VOLUNTARY EXCLUSION

This provision is applicable to all Federal-aid construction contracts, design-build contracts, subcontracts, lower-tier subcontracts, purchase orders, lease agreements, consultant contracts or any other covered transaction requiring FHWA approval or that is estimated to cost \$25,000 or more – as defined in 2 CFR Parts 180 and 1200.

1. Instructions for Certification – First Tier Participants:

- a. By signing and submitting this proposal, the prospective first tier participant is providing the certification set out below.
- b. The inability of a person to provide the certification set out below will not necessarily result in denial of participation in this covered transaction. The prospective first tier participant shall submit an explanation of why it cannot provide the certification set out below. The certification or explanation will be considered in connection with the department or agency's determination whether to enter into this transaction. However, failure of the prospective first tier participant to furnish a certification or an explanation shall disqualify such a person from participation in this transaction.
- c. The certification in this clause is a material representation of fact upon which reliance was placed when the contracting agency determined to enter into this transaction. If it is later determined that the prospective participant knowingly rendered an erroneous certification, in addition to other remedies available to the Federal Government, the contracting agency may terminate this transaction for cause of default.
- d. The prospective first tier participant shall provide immediate written notice to the contracting agency to whom this proposal is submitted if any time the prospective first tier participant learns that its certification was erroneous when submitted or has become erroneous by reason of changed circumstances.
- e. The terms "covered transaction," "debarred," "suspended," "ineligible," "participant," "person," "principal," and "voluntarily excluded," as used in this clause, are defined in 2 CFR Parts 180 and 1200. "First Tier Covered Transactions" refers to any covered transaction between a grantee or subgrantee of Federal funds and a participant (such as the prime or general contractor). "Lower Tier Covered Transactions" refers to any covered transaction under a First Tier Covered Transaction (such as subcontracts). "First Tier Participant" refers to the participant who has entered into a covered transaction with a grantee or subgrantee of Federal funds (such as the prime or general contractor). "Lower Tier Participant" refers any participant who has entered into a covered transaction with a First Tier Participant or other Lower Tier Participants (such as subcontractors and suppliers).
- f. The prospective first tier participant agrees by submitting this proposal that, should the proposed covered transaction be entered into, it shall not knowingly enter into any lower tier covered transaction with a person who is debarred, suspended, declared ineligible, or voluntarily excluded from participation in this covered transaction, unless authorized by the department or agency entering into this transaction.
- g. The prospective first tier participant further agrees by submitting this proposal that it will include the clause titled "Certification Regarding Debarment, Suspension, Ineligibility and Voluntary Exclusion-Lower Tier Covered Transactions," provided by the department or contracting agency, entering into this covered transaction, without modification, in all lower tier covered transactions and in all solicitations for lower tier covered transactions exceeding the \$25,000 threshold.
- h. A participant in a covered transaction may rely upon a certification of a prospective participant in a lower tier covered transaction that is not debarred, suspended, ineligible, or voluntarily excluded from the covered transaction, unless it knows that the certification is erroneous. A participant is responsible for ensuring that its principals are not suspended, debarred, or otherwise ineligible to participate in covered transactions. To verify the eligibility of its principals, as well as the eligibility of any lower tier prospective participants, each participant may, but is not required to, check the Excluded Parties List System website (<https://www.epls.gov/>), which is compiled by the General Services Administration.
- i. Nothing contained in the foregoing shall be construed to require the establishment of a system of records in order to render in good faith the certification required by this clause. The knowledge and information of the prospective participant is not required to exceed that which is normally possessed by a prudent person in the ordinary course of business dealings.
- j. Except for transactions authorized under paragraph (f) of these instructions, if a participant in a covered transaction knowingly enters into a lower tier covered transaction with a person who is suspended, debarred, ineligible, or voluntarily excluded from participation in this transaction, in addition to other remedies available to the Federal Government, the department or agency may terminate this transaction for cause or default.

* * * * *

2. Certification Regarding Debarment, Suspension, Ineligibility and Voluntary Exclusion – First Tier Participants:

- a. The prospective first tier participant certifies to the best of its knowledge and belief, that it and its principals:
 - (1) Are not presently debarred, suspended, proposed for debarment, declared ineligible, or voluntarily excluded from participating in covered transactions by any Federal department or agency;
 - (2) Have not within a three-year period preceding this proposal been convicted of or had a civil judgment rendered against them for commission of fraud or a criminal offense in connection with obtaining, attempting to obtain, or performing a public (Federal, State or local) transaction or contract under a public transaction; violation of Federal or State antitrust statutes or commission of embezzlement, theft, forgery, bribery, falsification or destruction of records, making false statements, or receiving stolen property;
 - (3) Are not presently indicted for or otherwise criminally or civilly charged by a governmental entity (Federal, State or local) with commission of any of the offenses enumerated in paragraph (a)(2) of this certification; and
 - (4) Have not within a three-year period preceding this application/proposal had one or more public transactions (Federal, State or local) terminated for cause or default.
- b. Where the prospective participant is unable to certify to any of the statements in this certification, such prospective participant shall attach an explanation to this proposal.

2. Instructions for Certification - Lower Tier Participants:

(Applicable to all subcontracts, purchase orders and other lower tier transactions requiring prior FHWA approval or estimated to cost \$25,000 or more - 2 CFR Parts 180 and 1200)

- a. By signing and submitting this proposal, the prospective lower tier is providing the certification set out below.
- b. The certification in this clause is a material representation of fact upon which reliance was placed when this transaction was entered into. If it is later determined that the prospective lower tier participant knowingly rendered an erroneous certification, in addition to other remedies available to the Federal Government, the department, or agency with which this transaction originated may pursue available remedies, including suspension and/or debarment.
- c. The prospective lower tier participant shall provide immediate written notice to the person to which this proposal is submitted if at any time the prospective lower tier participant learns that its certification was erroneous by reason of changed circumstances.
- d. The terms "covered transaction," "debarred," "suspended," "ineligible," "participant," "person," "principal," and "voluntarily excluded," as used in this clause, are defined in 2 CFR Parts 180 and 1200. You may contact the person to which this proposal is submitted for assistance in obtaining a copy of those regulations. "First Tier Covered Transactions" refers to any covered transaction between a grantee or subgrantee of

Federal funds and a participant (such as the prime or general contract). "Lower Tier Covered Transactions" refers to any covered transaction under a First Tier Covered Transaction (such as subcontracts). "First Tier Participant" refers to the participant who has entered into a covered transaction with a grantee or subgrantee of Federal funds (such as the prime or general contractor). "Lower Tier Participant" refers to any participant who has entered into a covered transaction with a First Tier Participant or other Lower Tier Participants (such as subcontractors and suppliers).

- e. The prospective lower tier participant agrees by submitting this proposal that, should the proposed covered transaction be entered into, it shall not knowingly enter into any lower tier covered transaction with a person who is debarred, suspended, declared ineligible, or voluntarily excluded from participation in this covered transaction, unless authorized by the department or agency with which this transaction originated.
- f. The prospective lower tier participant further agrees by submitting this proposal that it will include this clause titled "Certification Regarding Debarment, Suspension, Ineligibility and Voluntary Exclusion-Lower Tier Covered Transaction," without modification, in all lower tier covered transactions and in all solicitations for lower tier covered transactions exceeding the \$25,000 threshold.
- g. A participant in a covered transaction may rely upon a certification of a prospective participant in a lower tier covered transaction that is not debarred, suspended, ineligible, or voluntarily excluded from the covered transaction, unless it knows that the certification is erroneous. A participant is responsible for ensuring that its principals are not suspended, debarred, or otherwise ineligible to participate in covered transactions. To verify the eligibility of its principals, as well as the eligibility of any lower tier prospective participants, each participant may, but is not required to, check the Excluded Parties List System website (<https://www.epls.gov/>), which is compiled by the General Services Administration.
- h. Nothing contained in the foregoing shall be construed to require establishment of a system of records in order to render in good faith the certification required by this clause. The knowledge and information of participant is not required to exceed that which is normally possessed by a prudent person in the ordinary course of business dealings.
- i. Except for transactions authorized under paragraph e of these instructions, if a participant in a covered transaction knowingly enters into a lower tier covered transaction with a person who is suspended, debarred, ineligible, or voluntarily excluded from participation in this transaction, in addition to other remedies available to the Federal Government, the department or agency with which this transaction originated may pursue available remedies, including suspension and/or debarment.

* * * * *

Certification Regarding Debarment, Suspension, Ineligibility and Voluntary Exclusion--Lower Tier Participants:

1. The prospective lower tier participant certifies, by submission of this proposal, that neither it nor its principals is presently debarred, suspended, proposed for debarment, declared ineligible, or voluntarily excluded from participating in covered transactions by any Federal department or agency.
2. Where the prospective lower tier participant is unable to certify to any of the statements in this certification, such prospective participant shall attach an explanation to this proposal.

* * * * *

XI. CERTIFICATION REGARDING USE OF CONTRACT FUNDS FOR LOBBYING

This provision is applicable to all Federal-aid construction contracts and to all related subcontracts which exceed \$100,000 (49 CFR 20).

1. The prospective participant certifies, by signing and submitting this bid or proposal, to the best of his or her knowledge and belief, that:
 - a. No Federal appropriated funds have been paid or will be paid, by or on behalf of the undersigned, to any person for influencing or attempting to influence an officer or employee of any Federal agency, a Member of Congress, an officer or employee of Congress, or an employee of a Member of Congress in connection with the awarding of any Federal contract, the making of any Federal grant, the making of any Federal loan, the entering into of any cooperative agreement, and the extension, continuation, renewal, amendment, or modification of any Federal contract, grant, loan, or cooperative agreement.
 - b. If any funds other than Federal appropriated funds have been paid or will be paid to any person for influencing or attempting to influence an officer or employee of any Federal agency, a Member of Congress, an officer or employee of Congress, or an employee of a Member of Congress in connection with this Federal contract, grant, loan, or cooperative agreement, the undersigned shall complete and submit Standard Form-LLL, "Disclosure Form to Report Lobbying," in accordance with its instructions.
2. This certification is a material representation of fact upon which reliance was placed when this transaction was made or entered into. Submission of this certification is a prerequisite for making or entering into this transaction imposed by 31 U.S.C. 1352. Any person who fails to file the required certification shall be subject to a civil penalty of not less than \$10,000 and not more than \$100,000 for each such failure.
3. The prospective participant also agrees by submitting its bid or proposal that the participant shall require that the language of this certification be included in all lower tier subcontracts, which exceed \$100,000 and that all such recipients shall certify and disclose accordingly.

STANDARD SPECIAL PROVISION
MINIMUM WAGES

GENERAL DECISION ~~NC180103~~ ~~NC190090~~ 01/05/2018 ~~NC10304~~/2019 NC90

Z-403090

Date: January ~~5, 2018~~, 2019General Decision Number: ~~NC180103~~ ~~NC190090~~ 01/05/2018 ~~NC10304~~/2019 NC90Superseded General Decision Numbers: ~~NC20170103~~ NC20180103

State: North Carolina

Construction Type: HIGHWAY

COUNTIES:

Brunswick	Greene	Onslow
Cumberland	Hoke	Pender
Currituck	Johnston	Pitt
Edgecombe	Nash	Wake
Franklin	New Hanover	Wayne

HIGHWAY CONSTRUCTION PROJECTS (excluding tunnels, building structures in rest area projects & railroad construction; bascule, suspension & spandrel arch bridges designed for commercial navigation, bridges involving marine construction; and other major bridges).

Note: Under Executive Order (EO) 13658, an hourly minimum wage of \$10.~~35~~60 for calendar year ~~2018~~2019 that applies to all contracts subject to the Davis-Bacon Act for which the contract is awarded (and any solicitation was issued) on or after January 1, 2015. If this contract is covered by the EO, the contractor must pay all workers in any classification listed on this wage determination at least \$10.~~35~~60 per hour (or the applicable wage rate listed on this wage determination, if it is higher) for all hours spent performing on the contract for calendar year ~~2018~~2019. If this contract is covered by the EO and a classification considered necessary for performance of work on the contract must pay workers in that classification at least the wage rate determined through the conformance process set forth in 29 CFR.5.5(a)(1)(ii) (or the EO minimum wage rate, if it is higher than the conformed wage rate). The EO minimum wage rate will be adjusted annually. Please note that this EO applies to the above-mentioned types of contracts entered into by the federal government that are subject to the Davis-Bacon Act itself, but it does not apply to contracts subject only to the Davis-Bacon Related Acts, including those set forth at 29 CFR 5.1(a)(2) – (60). Additional information on contractor requirements and worker protections under the EO is available at www.dol.gov/whd/govcontracts.

Modification Number
0Publication Date
01/~~05/2018~~04/2019

SUNC2014-005 11/17/2014

	Rates	Fringes
BLASTER	21.04	
CARPENTER	13.72	
CEMENT MASON+/-CONCRETE FINISHER	14.48	
ELECTRICIAN		
Electrician	17.97	
Telecommunications Technician	16.79	.63
IRONWORKER	16.02	
LABORER		
Asphalt Raker and Spreader	12.46	
Asphalt Screed+/-Jackman	14.33	
Carpenter Tender	12.88	
Cement Mason+/-Concrete Finisher Tender	12.54	
Common or General	10. 35 20	
Guardrail+/-Fence Installer	12.87	
Pipelayer	12.17	
Traffic Signal+/-Lighting Installer	14.89	
PAINTER		
Bridge	24.57	
POWER EQUIPMENT OPERATORS		
Asphalt Broom Tractor	11.85	
Bulldozer Fine	17.04	
Bulldozer Rough	14.34	
Concrete Grinder+/-Groover	20.34	2.30
Crane Boom Trucks	20.54	
Crane Other	20.08	
Crane Rough+/-All-Terrain	20.67	
Drill Operator Rock	14.38	
Drill Operator Structure	21.14	
Excavator Fine	16.60	
Excavator Rough	14.00	
Grader+/-Blade Fine	18.47	
Grader+/-Blade Rough	14.62	
Loader 2 Cubic Yards or Less	13.76	
Loader Greater Than 2 Cubic Yards	14.14	
Material Transfer Vehicle (Shuttle Buggy)	15.18	
Mechanic	17.55	
Milling Machine	15.36	
Off-Road Hauler+/-Water Tanker	11.36	
Oiler+/-Greaser	13.55	
Pavement Marking Equipment	12.11	
Paver Asphalt	15.59	
Paver Concrete	18.20	
Roller Asphalt Breakdown	12.45	
Roller Asphalt Finish	13.85	
Roller Other	11.36	
Scraper Finish	12.71	
Scraper Rough	11.35	
Slip Form Machine	16.50	
Tack Truck+/-Distributor Operator	14.52	

	Rates	Fringes
TRUCK DRIVER		
GVWR of 26,000 Lbs or Less	11.12	
GVWR of 26,000 Lbs or Greater	12.37	

Welders – Receive rate prescribed for craft performing operation to which welding is incidental.

Note: Executive Order (EO) 13706, Establishing Paid Sick Leave for Federal Contractors applies to all contracts subject to the Davis-Bacon Act for which the contract is awarded (and any solicitation was issued) on or after January 1, 2017. If this contract is covered by the EO, the contractor must provide employees with 1 hour of paid sick leave for every 30 hours they work, up to 56 hours of paid sick leave each year. Employees must be permitted to use paid sick leave for their own illness, injury or other health-related needs, including preventive care; to assist a family member (or person who is like family to the employee) who is ill, injured, or has other health-related needs, including preventive care; or for reasons resulting from, or to assist a family member (or person who is like family to the employee) who is a victim of, domestic violence, sexual assault, or stalking. Additional information on contractor requirements and worker protections under the EO is available at www.dol.gov/whd/govcontracts.

Unlisted classifications needed for work not included within the scope of the classifications listed may be added after award only as provided in the labor standards contract clauses (29 CFR 5.5(a)(1)(ii)).

The body of each wage determination lists the classification and wage rates that have been found to be prevailing for the cited type(s) of construction in the area covered by the wage determination. The classifications are listed in alphabetical order of "identifiers" that indicate whether the particular rate is a union rate (current union negotiated rate for local), a survey rate (weighted average rate) or a union average rate (weighted union average rate).

Union Rate Identifiers

A four letter classification abbreviation identifier enclosed in dotted lines beginning with characters other than "SU" or "UAVG" denotes that the union classification and rate were prevailing for that classification in the survey. Example: PLUM0198-005 07/01/2014. PLUM is an abbreviation identifier of the union which prevailed in the survey for this classification, which in this example would be Plumbers. 0198 indicates the local union number or district council number where applicable, i.e., Plumbers Local 0198. The next number, 005 in the example, is an internal number used in processing the wage determination. 07/01/2014 is the effective date of the most current negotiated rate, which in this example is July 1, 2014.

Union prevailing wage rates are updated to reflect all rate changes in the collective bargaining agreement (CBA) governing this classification and rate.

Survey Rate Identifiers

Classifications listed under the "SU" identifier indicate that no one rate prevailed for this classification in the survey and the published rate is derived by computing a weighted average rate based on all the rates reported in the survey for that classification. As this weighted average rate includes all rates reported in the survey, it may include both union and non-union rates. Example:

SULA2012-007 5/13/2014. SU indicates the rates are survey rates based on a weighted average calculation of rates and are not majority rates. LA indicates the State of Louisiana. 2012 is the year of survey on which these classifications and rates are based. The next number, 007 in the example, is an internal number used in producing the wage determination. 5/13/2014 indicates the survey completion date for the classifications and rates under that identifier. Survey wage rates are not updated and remain in effect until a new survey is conducted.

Union Average Rate Identifiers

Classification(s) listed under the UAVG identifier indicate that no single majority rate prevailed for those classifications; however, 100% of the data reported for the classifications was union data. EXAMPLE: UAVG-OH-0010 08/29/2014. UAVG indicates that the rate is a weighted union average rate. OH indicates the state. The next number, 0010 in the example, is an internal number used in producing the wage determination. 08/29/2014 indicates the survey completion date for the classifications and rates under that identifier.

A UAVG rate will be updated once a year, usually in January of each year, to reflect a weighted average of the current negotiated/CBA rate of the union locals from which the rate is based.

WAGE DETERMINATION APPEALS PROCESS

1.) Has there been an initial decision in the matter? This can be:

- * an existing published wage determination
- * a survey underlying a wage determination
- * a Wage and Hour Division letter setting forth a position on a wage determination matter
- * a conformance (additional classification and rate) ruling

On survey related matters, initial contact, including requests for summaries of surveys, should be with the Wage and Hour Regional Office for the area in which the survey was conducted because those Regional Offices have responsibility for the Davis-Bacon survey program. If the response from this initial contact is not satisfactory, then the process described in 2.) and 3.) should be followed.

With regard to any other matter not yet ripe for the formal process described here, initial contact should be with the Branch of Construction Wage Determinations. Write to:

Branch of Construction Wage Determinations
Wage and Hour Division
U. S. Department of Labor
200 Constitution Avenue, N.W.
Washington, D.C. 20210

2.) If the answer to the question in 1.) is yes, then an interested party (those affected by the action) can request review and reconsideration from the Wage and Hour Administrator (See 29 CFR Part 1.8 and 29 CFR Part 7). Write to:

Wage and Hour Administrator
U.S. Department of Labor
200 Constitution Avenue, N.W.
Washington, D.C. 20210

The request should be accompanied by a full statement of the interested party's position and by any information (wage payment data, project description, area practice material, etc.) that the requestor considers relevant to the issue.

- 3.) If the decision of the Administrator is not favorable, an interested party may appeal directly to the Administrative Review Board (formerly the Wage Appeals Board). Write to:

Administrative Review Board
U.S. Department of Labor
200 Constitution Avenue, N.W.
Washington, D.C. 20210

- 4.) All decisions by the Administrative Review Board are final.
END OF GENERAL DECISION

STANDARD SPECIAL PROVISION**ERRATA**

(10-16-18) (Rev.1-15-19)

Z-4

Revise the *2018 Standard Specifications* as follows:

Division 6

Page 6-7, Article 609-1 DESCRIPTION, line 29, replace article number “609-10” with “609-9”.

Division 10

Page 10-78, Article 1056-4 GEOTEXTILES, TABLE 1056-1, Permittivity, Type 2, replace “Table 6^D” with “Table 7^D” and **Permittivity, Type 3^B,** replace “Table 7^D” with “Table 8^D”.

Page 10-162, Article 1080-50 PAINT FOR VERTICAL MARKERS, line 1, replace article number “1080-50” with “1080-10”.

Page 10-162, Article 1080-61 EPOXY RESIN FOR REINFORCING STEEL, line 5, replace article number “1080-61” with “1080-11”.

Page 10-162, Article 1080-72 ABRASIVE MATERIALS FOR BLAST CLEANING STEEL, line 22, replace article number “1080-72” with “1080-12”.

Page 10-163, Article 1080-83 FIELD PERFORMANCE AND SERVICES, line 25, replace article number “1080-83” with “1080-13”.

***** STANDARD SPECIAL PROVISIONS *******DIVISION ONE OF STANDARD SPECIFICATIONS**

Division One of the 2018 NCDOT *Standard Specifications for Roads and Structures (Standard Specifications)* shall apply except as follows:

Definitions: Throughout Division One of the 2018 NCDOT *Standard Specifications for Roads and Structures*, the term “Contractor” is replaced with “Design-Build Team”, the term “Bidder” is replaced with “Proposer,” the term “Bid” is replaced by “Price Proposal,” and the phrase “lowest Responsible Bidder” is replaced with “responsible Proposer with the lowest adjusted price.” The replacement of “Contractor” with “Design-Build Team” does not apply to Article 102-2. The replacement of the above terms also does not apply when the terms are part of a phrase (e.g. bid bond, prime contractor, total amount bid, etc.)

Deletions: Articles 102-3(B), 102-4, 102-8(B), 102-9(C)(2), 103-2(B), 103-4(C), and 104-5 of the 2018 NCDOT *Standard Specifications for Roads and Structures* are deleted from Design-Build Contracts.

Modifications: The remainder of this Standard Special Provision includes modifications to Division One of the 2018 NCDOT *Standard Specifications for Roads and Structures*.

**SECTION 101
DEFINITION OF TERMS**

Page 1-3, Article 101-3, replace and add certain definitions as follows:

ADDITIONAL WORK

Additional work is that which results from a change or alteration to the contract and for which there are contract unit prices in the original contract or an executed supplemental agreement.

ADVERTISEMENT

The public advertisement inviting Statements of Qualifications for the design and construction of specific projects.

AWARD

The decision of the Department of Transportation to accept the proposal of the selected Design-Build Team for work which is subject to the furnishing of payment and performance bonds, and such other conditions as may be otherwise provided by law, the Request for Proposals, and the 2018 NCDOT *Standard Specifications for Roads and Structures*.

CONTRACT

The executed agreement between the Department and the successful proposer, covering the performance of, and compensation for, the work. The term contract is all inclusive with reference to all written agreements affecting a contractual relationship and all documents referred to therein. The contract shall include, but not be limited to, the Request for Proposals, the Technical

Proposal, the Price Proposal, the printed contract form and attachments, contract bonds, plans and associated special provisions prepared by the Design-Build Team, standard specifications and supplemental specifications, standard special provisions and project special provisions contained in the Request for Proposals or as developed by the Design-Build Team and accepted by the Department, and all executed supplemental agreements. The contract shall constitute one instrument.

DATE OF AVAILABILITY

That date, established as set forth in the Request for Proposals, by which it is anticipated that the Contract will be executed and sufficient design efforts or work sites within the project limits will be available for the Design-Build Team to begin his controlling operations or design.

DESIGN-BUILD

A form of contracting in which the successful proposer undertakes responsibility for both the design and construction of a project.

DESIGN-BUILD TEAM

An individual, partnership, joint venture, corporation or other legal entity that furnishes the necessary design and construction services, whether by itself or through subcontracts.

DESIGN-BUILD PROPOSAL

A proposal to contract consisting of a separately sealed Technical Proposal and a separately sealed Price Proposal submitted in response to a Request for Proposals on a Design-Build project.

PLANS

The project plans, Standard Drawings, working drawings and supplemental drawings, or reproductions thereof, accepted by the Engineer, which show the location, character, dimensions and details of the work to be performed. Unless otherwise noted within the Request for Proposals, the term “plans” refers to plans as developed by the Design-Build Team and accepted by the Department.

(A) Standard Drawings:

Drawings approved for repetitive use, showing details to be used where appropriate. All Standard Drawings approved by the Department plus subsequent revisions and additions. Standard Drawings are available for purchase from:

State Contract Officer
1591 Mail Service Center
Raleigh, NC 27699-1591

(B) Preliminary Plans:

Department-furnished drawings distributed in concert with a Request for Proposals, or as developed by the Design-Build Team.

(C) Project Plans:

Construction drawings prepared, sealed and completed by the Design-Build Team, or as provided by the Department, that contain specific details and dimensions specific to the work.

(D) Working Drawings and Supplemental Drawings:

Supplemental design sheets, shop drawings, or similar data which the Design-Build Team is required to submit to the Engineer.

(E) As-Constructed Drawings:

Red-lined mark-up of the latest Released for Construction (RFC) Plans containing the information listed under As-Constructed Plans in the Records and Reports Section of the NCDOT Construction Manual.

(F) As-Built Plans:

Coordinately correct plans documenting the details, dimensions and locations of the completed work.

PRICE PROPOSAL

The offer of a Proposer, submitted on the prescribed forms, to perform the work and furnish the labor and materials at the price quoted.

PROJECT SCHEDULE

The Critical Path Model employed by the Design-Build Team to guide their work and subject to review by the Department.

PROPOSAL (OR REQUEST FOR PROPOSALS)

The paper document provided by the Department that the proposer uses to develop his paper offer to perform the work at designated bid prices.

PROPOSER

An individual, partnership, firm, corporation, LLC, or joint venture formally submitting a Technical Proposal and Price Proposal in response to a Request for Proposals.

RIGHT OF WAY

The land area shown on the plans as right of way within which the project is to be constructed.

SCHEDULE OF VALUES

A schedule of work items necessary to complete work, along with the progress of each work item, primarily for the purpose of partial payments.

TABLE OF QUANTITIES

A listing of work items (corresponding to the items in the Transport pay item list) that contributes to a project completion. The table shall include estimated quantities for each work item.

TECHNICAL PROPOSAL

A submittal from a proposer, in accordance with requirements of the Request for Proposals, for the purpose of final selection. The Technical Proposal is defined to also include any supplemental information requested by the Department from a proposer prior to opening bids.

SECTION 102 PROPOSAL REQUIREMENTS AND CONDITIONS

Page 1-9, delete Article 102-1 and replace with the following:

102-1 INVITATION TO BID

After the advertisement has been made, an Invitation to Bid will be made available to known prequalified contractors and any other contracting firms, material suppliers and other interested parties who have requested they be placed on the Invitation to Bid mailing list, informing them that Statements of Qualifications and Proposals will be received for the construction of specific projects. Such invitation will indicate the contract identification number, length, locations and descriptions; a general summary of the scope of work to be performed; and information on how to receive a Request for Qualifications.

All projects will be advertised in daily newspapers throughout the state before the bid opening.

Page 1-12, delete Article 102-3 and replace with the following:

102-3 CONTENTS OF REQUEST FOR PROPOSALS

A Request for Proposals will be furnished by the Department to the selected proposers from among the respondents to the Request for Qualifications. Each Request for Proposals will be marked on the front cover by the Department with an identifier of the Proposer to whom it is being furnished. This Request for Proposals will state the location of the project and will show a schedule of contract items for which Technical and Price Proposals are invited. It will set forth the dates and times Technical and Price Proposals are to be submitted and when the Price Proposals will be opened. The Request for Proposals will also include special provisions or requirements that vary from or are not contained in any preliminary design information or standard specifications.

The Request for Proposals will also include the printed contract forms and signature sheets for execution by both parties to the contract. In the event the Proposer is awarded the contract, execution of the Request for Proposals by the Proposer is considered the same as execution of the contract.

Standard specifications, sealed plans specifically identified as the Department's responsibility and other documents designated in the Request for Proposals shall be considered a part of the Request for Proposals whether or not they are attached thereto. All papers bound with the proposal are necessary parts thereof and shall not be detached, taken apart, or altered.

The names and identity of each prospective Proposer that receives a copy of the Request for Qualifications for the purposes of submitting a Statement of Qualifications shall be made public,

except that a potential Proposer who obtains a Request for Qualifications may, at the time of ordering, request that his name remain confidential.

One copy of the Final Request for Proposals will be furnished to each prospective Proposer. Additional copies may be purchased for the sum of \$25 each. The copy of the Final Request for Proposals marked with the Proposer's name and prequalification number shall be returned to the Department as the Proposer's Price Proposal.

Page 1-14, Article 102-7, 4th paragraph, delete the first two sentences and replace with the following:

Details shown in the subsurface investigation report are preliminary only. The subsurface investigation and subsurface report, if provided, are done so for information purposes only.

Pages 1-14, delete Article 102-8 and replace with the following:

102-8 PREPARATION AND SUBMISSION OF BIDS

All Price Proposals shall be prepared and submitted in accordance with the following requirements:

1. The Request for Proposals provided by the Department shall be used and shall not be taken apart or altered. The Price Proposal shall be submitted on the same form, which has been furnished to the Proposer by the Department as identified by the Proposer's name marked on the front cover by the Department.
2. All entries including signatures shall be written in ink.
3. The Proposer shall submit a lump sum or unit price for every item in the Price Proposal. The lump sum or unit prices bid for the various contract items shall be written in figures.
4. An amount bid shall be entered in the Request for Proposals for every item and the price shall be written in figures in the "Amount Bid" column in the Request for Proposals.
5. An amount bid shall be entered in the proposal for every item on which a unit price has been submitted. The amount bid for each item other than lump sum items shall be determined by multiplying each unit bid price by the quantity for that item and shall be written in figures in the Amount Bid column in the proposal.
6. The total amount bid shall be written in figures in the proper place in the Request for Proposals. The total amount bid shall be determined by adding the amounts bid for each lump sum item.
7. Changes in any entry shall be made by marking through the entry in ink and making the correct entry adjacent thereto in ink. A representative of the Proposer shall initial the change in ink.
8. The Price Proposal shall be properly executed. To constitute proper execution, the Price Proposal shall be executed in strict compliance with the following:
 - a. If a Price Proposal is by an individual, it shall show the name of the individual and shall be signed by the individual with the word "Individually" appearing under the

- signature. If the individual operates under a firm name, the bid shall be signed in the name of the individual doing business under the firm name.
- b. If the Price Proposal is by a corporation, it shall be executed in the name of the corporation by the President, Vice President, or Assistant Vice President. It shall be attested by the Secretary or Assistant Secretary. The seal of the corporation shall be affixed. If the Price Proposal is executed on behalf of a corporation in any other manner than as above, a certified copy of the minutes of the Board of Directors of said corporation authorizing the manner and style of execution and the authority of the person executing shall be attached to the Price Proposal or shall be on file with the Department.
 - c. If the Price Proposal is made by a partnership, it shall be executed in the name of the partnership by one of the general partners.
 - d. If the Price Proposal is made by a limited liability company, it shall be signed by the manager, member, or authorized agent.
 - e. If the Price Proposal is made by a joint venture, it shall be executed by each of the joint venturers in the appropriate manner set out above. In addition, the execution by the joint venturers shall appear below their names.
9. The Price Proposal shall not contain any unauthorized additions, deletions, or conditional bids.
 10. The Proposer shall not add any provision reserving the right to accept or reject an award or to enter into a contract pursuant to an award.
 11. The Price Proposal shall be accompanied by a bid bond on the form furnished by the Department or by a bid deposit. The bid bond shall be completely and properly executed in accordance with the requirements of Article 102-10 and as modified herein. The bid deposit shall be a certified check or cashier check in accordance with Article 102-10 and as modified herein.
 12. The Price Proposal shall be placed in a sealed envelope and shall have been delivered to and received by the Department prior to the time specified in the Request for Proposals.

Page 1-17, Article 102-10, 3rd paragraph, delete the fifth sentence and replace with the following:

The condition of the bid bond or bid deposit is: the Principal shall not withdraw its bid within 270 days after the submittal of the same, and if the Department shall award a contract to the Principal, the Principal shall within 14 calendar days after the written solicitation of said bonds is received by him, give payment and performance bonds with good and sufficient surety as required for the faithful performance of the contract and for the protection of all persons supplying labor and materials in the prosecution of the work.

Page 1-18, Article 102-10, delete the end of the Article beginning with, and inclusive of, the 6th paragraph.

Pages 1-18, delete Article 102-12 and replace with the following:

102-12 WITHDRAWAL OR REVISION OF BIDS

A Design-Build Team will not be permitted to withdraw its Technical and/or Price Proposals after they have been submitted to the Department, unless allowed under Article 103-3 or unless otherwise approved by the NCTA Chief Engineer.

Page 1-19, delete Article 102-13 and replace with the following:

102-13 RECEIPT AND OPENING OF BIDS

Price Proposals from shortlisted Proposers will be opened and read publicly on the date and time indicated in the Request for Proposals. The Technical Scores of the previously conducted evaluation of the Technical Proposals will also be read publicly in accordance with the procedures outlined in the Request for Proposals. Proposers, their authorized agents, and other interested parties are invited to be present.

Page 1-19, Article 102-14, replace the 1st paragraph with the following:

102-14 REJECTION OF BIDS

Any Price Proposal submitted which fails to comply with any of the requirements of Articles 102-8, 102-9 or 102-10, or with the requirements of the project scope and specifications shall be considered irregular and may be rejected. A Price Proposal that does not contain costs for all proposal items shall be considered irregular and may be rejected.

**SECTION 103
AWARD AND EXECUTION OF CONTRACT**

Page 1-21, delete Article 103-1 and replace with the following:

103-1 CONSIDERATION OF PRICE PROPOSALS

After the Price Proposals are opened and read, they will be tabulated. The Price Proposal and Technical Score of the Technical Proposal will be made available in accordance with procedures outlined in the Request for Proposals. In the event of errors, omissions, or discrepancies in the Price Proposal, corrections to the Price Proposal will be made in accordance with the provisions of Article 103-2. Such corrected bid prices will be used to determine the lowest adjusted price.

After the reading of the Price Proposals and Technical Scores, the Department will calculate the lowest adjusted price as described in the Request for Proposals.

The right is reserved to reject any or all Price Proposals, to waive technicalities, to request the Proposer with the lowest adjusted price to submit an up-to-date financial and operating statement, to advertise for new proposals, or to proceed to do the work otherwise, if in the judgment of the Department, the best interests of the State will be promoted thereby.

Page 1-21, Subarticle 103-2(A), add items (6) and (7) as follows:

(6) Discrepancy in the “Total Amount Bid” and the addition of the “Amount Bid” for each line Item

In the case of the Total Amount Bid does not equal the summation of each Amount Bid for the line items, the summation of each Amount Bid for the line items shall be deemed to be the correct Total Amount Bid for the entire project.

(7) Omitted Total Amount Bid –Amount Bid Completed

If the Total Amount Bid is not completed and the Amount Bid for all line items is completed the Total Amount Bid shall be the summation of the Amount Bid for all line items.

Page 1-23, Subarticle 103-3(C), replace all occurrences of "Chief Engineer" with "NCTA Chief Engineer."

Page 1-23, Subarticle 103-3(D), replace all occurrences of "Chief Engineer" with "NCTA Chief Engineer."

Page 1-23, Subarticle 103-4(A), first paragraph, replace the 3rd and 4th sentences with the following:

Where award is to be made, the notice of award will be issued within 75 days after the submittal of Price Proposals, except with the consent of the responsible Proposer with the lowest adjusted price the decision to award the contract to such bidder may be delayed for as long a time as may be agreed upon by the Department and such Proposer. In the absence of such agreement, the Proposer may withdraw his Price Proposal at the expiration of the 75 days without penalty if no notice of award has been issued.

Page 1-29, Article 103-6, delete the 1st and 2nd paragraphs and replace with the following:

Checks that have been furnished as a bid deposit will be retained until after the contract bonds have been furnished by the successful proposer, at which time the checks that were furnished as a bid deposit will be returned.

SECTION 104 SCOPE OF WORK

Page 1-30, delete Article 104-1 and replace with the following:

104-1 INTENT OF CONTRACT

The intent of the contract is to prescribe the work or improvements that the Design-Build Team undertakes to perform, in full compliance with the contract documents. In case the method of construction or character of any part of the work is not covered by the contract, this section shall apply. The Design-Build Team shall perform all work in accordance with the contract or as may be modified by written orders, and shall do such additional, extra, and incidental work as may be considered necessary to complete the work to the full intent of the contract. Unless otherwise

provided elsewhere in the contract, the Design-Build Team shall furnish all implements, machinery, equipment, tools, materials, supplies, transportation, and labor necessary for the design, prosecution and completion of the work.

Page 1-30, Article 104-3, replace “plans or details of construction” with “contract” in all instances within this Article.

Page 1-35, Article 104-8, add the following Subarticle to the end of this article:

(E) Coordination with CPM

If the Design-Build Team requests additional compensation in accordance with Articles 104-3, 104-7, and this Article, a fragmentary logic diagram (fragnet) shall be prepared and submitted with such request. A fragnet is defined as the sequence of new activities that are proposed to be added to the current schedule to represent the alleged cost and potential time impact(s). The fragnet shall be developed with sufficient detail to clearly depict the alleged change to the current schedule of record.

The Design-Build Team shall prepare the fragnet depicting all activities and costs associated with the request for additional compensation. The fragnet shall identify all predecessor and successor activities, any changes in durations of existing activities and any activities added to or deleted from the current schedule or record as a direct result of the request for additional compensation.

If the request for additional compensation is agreeable to the NCTA, the NCTA will evaluate the provided fragnet within current schedule of record as follows:

- (1) The Design-Build Team shall provide the fragnet, supporting information and narrative describing how the fragnet is incorporated (predecessors and successors) into the schedule referenced below.
- (2) The Design-Build Team shall update the current schedule of record to the anticipated supplemental agreement execution date and provide this schedule to the NCTA for review.
- (3) The Design-Build Team shall provide a separate updated schedule, as defined in item 2 above, with the fragnet inserted.
- (4) The revised Scheduled Completion Date will be evaluated by the NCTA; and
- (5) If the associated time difference in the above Scheduled Completion Dates (items 2 and 3 above) results in a time extension, such extension will be provided within the supplemental agreement. If project float is created by the work, it will be encompassed within the modified and updated schedule of record. Both the Design-Build Team and the NCTA will have access to this float as detailed in Article 108-2 of this Standard Special Provision.

Page 1-36, Subarticle 104-8(B), 2nd paragraph, delete the first sentence and replace with the following:

If the contractor chooses to pursue the claim after the disputed work is complete, he shall submit a written claim to the Engineer for an adjustment in compensation based upon his cost records within 90 calendar days after completion of the disputed work.

Page 1-36, Subarticle 104-8(B), 6th paragraph, delete the sixth bullet and replace with the following:

- (6) The failure of the Contractor to submit the written request for an adjustment in compensation with cost records and supporting information within 90 days of completion of the affected work.

Page 1-39, Article 104-10, replace the first paragraph with the following:

104-10 MAINTENANCE OF THE PROJECT

The Design-Build Team shall maintain the project from the date of beginning construction on the project until the project is finally accepted. For sections of facilities impacted by utility construction/relocation performed by the Design-Build Team prior to beginning construction on the roadway project, maintenance of the impacted sections of facilities shall be performed by the Design-Build Team beginning concurrently with the impact. All existing and constructed guardrail/guiderail within the project limits shall be included in this maintenance. This maintenance shall be continuous and effective and shall be prosecuted with adequate equipment and forces to the end that all work covered by the contract is kept in satisfactory and acceptable conditions at all times. The Design-Build Team shall perform weekly inspections of guardrail and guiderail and shall report damages to the Engineer on the same day of the weekly inspection. Where damaged guardrail or guiderail is repaired or replaced as a result of maintaining the project in accordance with this Article, such repair or replacement shall be performed within seven consecutive calendar days of such inspection report.

Page 1-39, Article 104-10, add the following after the last paragraph:

The Design-Build Team will not be compensated for performance of weekly inspections and damage reports for the guardrail/guiderail. Other maintenance activities for existing guardrail/guiderail will be handled in accordance with Articles 104-7 and 104-8.

SECTION 105 CONTROL OF WORK

Pages 1-44, delete Article 105-2 and replace with the following:

105-2 PLANS AND WORKING DRAWINGS

All plans shall be supplemented by such approved working drawings as are necessary to adequately control the work. Working drawings furnished by the Design-Build Team and

approved by the Engineer shall consist of such detailed drawings as may be required to adequately control the work. They may include stress sheets, shop drawings, erection drawings, falsework drawings, cofferdam drawings, bending diagrams for reinforcing steel, catalog cuts, or any other supplementary drawings or similar data required of the Design-Build Team. When working drawings are approved by the Engineer, such approval shall not operate to relieve the Design-Build Team of any of his responsibility under the contract for the successful completion of the work.

Changes on shop drawings after approval and/or distribution shall be subject to the approval of the Engineer and he shall be furnished a record of such changes.

Page 1-45, Article 105-3, add the following after the 3rd paragraph:

The Design-Build Team shall bear all the costs of providing the burden of proof that the nonconforming work is reasonable and adequately addresses the design purpose. The Design-Build Team shall bear all risk for continuing with nonconforming work in question until it is accepted.

The Engineer may impose conditions for acceptance of the nonconforming work. The Design-Build Team shall bear all costs for fulfilling the conditions.

The decisions whether the product satisfies the design purpose, whether the nonconforming work is reasonably acceptable and the conditions for acceptance are at the sole discretion of the Engineer.

Pages 1-45, delete Article 105-4 and replace with the following:

105-4 COORDINATION OF PLANS, SPECIFICATIONS, SUPPLEMENTAL SPECIFICATIONS, AND SPECIAL PROVISIONS

The Request for Proposals, all construction Plans, the Standard Specifications, Supplemental Specifications and Special Provisions and all supplementary documents are essential parts of the contract and a requirement occurring in one is as binding as though occurring in all. They are complementary and describe and provide the complete contract.

In case of discrepancy or conflict, the order in which they govern shall be as follows:

- (A) Request for Proposals, in which Project Special Provisions govern Standard Special Provisions
- (B) Technical Proposal from the Design-Build Team
- (C) Accepted Plans and Details from the Design-Build Team, or sealed plans provided by the Department, as applicable
- (D) Standard Drawings
- (E) Standard Specifications

Where dimensions on the plans are given or can be computed from other given dimensions they shall govern over scaled dimensions.

The Design-Build Team shall take no advantage of any error or omission in the plans, estimated quantities, or specifications. In the event the Design-Build Team discovers an error or omission, he shall immediately notify the Engineer.

Page 1-48, delete Article 105-9 and replace with the following:

105-9 CONSTRUCTION STAKES, LINES, AND GRADES

The Design-Build Team shall be responsible for all surveying, construction staking and layout required in the performance of the work. The Design-Build Team will be responsible for the accuracy of lines, slopes, grades and other engineering work which the Design-Build Team provides under this contract.

**SECTION 106
CONTROL OF MATERIAL**

Page 1-53, Article 106-2, add the following after the second paragraph:

Prior to beginning construction, the Design-Build Team shall provide a Table of Quantities as described in Article 101-3 of these specifications.

The Table of Quantities Work Items shall correspond to Pay Items as defined in the Standard Specifications. These Work Items have associated Materials and Conversion Factors. For non-standard Work Items, a Generic Work Item with the correct Unit of Measure and in an appropriate category will be used. For example, “GENERIC TRAFFIC CONTROL ITEM – EA” or “GENERIC RETAINING WALL ITEM – LF”. For these Generic Work Items, Materials must be defined and appropriate conversion factors submitted.

An initial Table of Quantities shall be submitted no later than 30 calendar days after the date of award. The Table of Quantities shall be updated and resubmitted within 14 days of when a set of Plans is sealed as Release for Construction (RFC) Plans, and whenever there are substantial changes to the Quantities on previously incorporated RFC Plans.

Page 1-55, Article 106-6, add the following after the last paragraph:

For items normally pretested by the Department, the Design-Build Team shall provide a minimum of 30 days notice prior to the beginning of production of the items for this project along with final approved shop drawings.

**SECTION 107
LEGAL RELATIONS AND RESPONSIBILITY
TO PUBLIC**

Page 1-57, replace the first paragraph of Article 107-1 with the following:

107-1 LAWS TO BE OBSERVED

The Contractor shall keep himself fully informed of all Federal, State and local laws, ordinances and regulations, and all orders and decrees of bodies or tribunals having any jurisdiction or authority which may in any manner affect those engaged or employed in the work or which in any way affect the conduct of the work. He shall at all times observe and comply with all such laws, ordinances, regulations, orders and decrees; and shall indemnify and hold harmless the Board of Transportation, the NCTA Board, the NCTA, and the Department and their agents and employees from any claim or liability arising from or based on the violation of any such law,

ordinance, regulation, order, or decree, by the Contractor or by his agents and employees. If during the course of the contract any such laws, ordinances and regulations, and all orders and decrees may be changed, the Contractor shall comply fully with the same.

Page 1-65, delete Article 107-18 and replace with the following:

107-18 FURNISHING RIGHT OF WAY

The responsibility for coordinating the securing of all necessary rights of way is as outlined in the Request for Proposals.

Page 1-66, delete Article 107-26 in its entirety and replace with the following:

107-26 FINES AND LEVIES AGAINST THE DEPARTMENT

In the event there are fines or charges levied against the Department, actions taken by the Department, or remediation required by the Department due to the contractor's negligence, carelessness, or failure, due to violations charged to the Contractor, or due to the Contractor's failure to comply with the contract, monies will be deducted from monies to be paid to the Contractor on this project.

**SECTION 108
PROSECUTION AND PROGRESS**

Page 1-68, Article 108-2, replace the entire article with the following:

108-2 COST-LOADED CRITICAL PATH METHOD PROJECT SCHEDULE

(A) General Requirements

The Design-Build Team shall create a Cost-Loaded Critical Path Method Project Schedule (CPM). The Design-Build Team shall include in the CPM, the work of subcontractors, vendors, suppliers, utilities, railroads, permitting agencies, NCDOT, NCTA, and all other parties associated with the Project. Failure by the Design-Build Team to include any element of its Work or the work of others required for completion of the Project will not excuse the Design-Build Team from completing the Project by the Contract Completion Date(s). The Design-Build Team shall assign a dollar value to each activity in the CPM. The Design-Build Team shall use the CPM to prepare its payment applications in accordance with Article 109-4(A) of the Standard Special Provisions, Division One, found elsewhere in this RFP. The Design-Build Team shall provide adequate time in the schedule for all parties involved with the Project to complete their Work, including inspections, procurement activities and testing. The Design-Build Team's plan, as presented in the CPM, shall adhere to all Contract requirements.

The Engineer's acceptance of any schedule does not relieve the Design-Build Team of responsibility for the accuracy or feasibility of the schedule, does not modify the contract, will not be construed as an endorsement or validation of the Design-Build Team's plan, and does not guarantee that the Project can be performed or completed as scheduled. The

Engineer's acceptance of the Design-Build Team's schedules in no way attests to the validity of the assumptions, logic constraints, dependency, relationships, resource allocations, resource availability, manpower and equipment, or any other aspect of the means and methods of performing the Work. The Design-Build Team is and shall remain solely responsible for the scheduling, planning, and execution of the Work in order to meet the Project Milestones, the Intermediate Contract Times, and the Contract Completion Date(s).

NCTA will only reimburse costs for delays as identified in Article 104-4 of the 2018 *NCDOT Standard Specifications for Roads and Structures*. Except for costs identified in Article 104-4, NCTA will not be responsible for additional or unabsorbed overhead costs resulting from delays, regardless of whether or not the delays were excusable.

Although the Design-Build Team may plan to achieve Substantial Completion or Final Completion early, in no event will the Design-Build Team be entitled to any additional compensation related to the inability to complete work in advance of the applicable contract deadline.

The Design-Build Team will not be permitted to submit a resource leveled schedule for the purposes of payment, determining expected start and finish dates, or the longest path of the schedule. Rather, the longest path and expected start and finish dates will be determined by logic, durations, and calendars.

Materials – The Design-Build Team shall produce every schedule referenced in this Provision and/or submitted to the Engineer on a computer using software and files that are compatible with the most recent version of Primavera.

Definitions – The following definitions apply solely to the terms used in this provision. The following definitions do not modify in any way the definitions provided elsewhere in the Contract Documents.

Activity – A discrete, identifiable task or event that takes time, has definable start and stop dates, furthers the Work's progress, and can be used to plan, schedule, and monitor a project.

Activity Calendar – A set of days assigned to an activity on which work associated with the activity may be scheduled.

Activity Code – Additional information assigned to an activity for purposes of grouping or filtering related activities. Common codes include phase, area, responsibility, subcontractor, type of work, and sub phase.

Activity ID – A unique, alphanumeric, identification code assigned to an activity.

Actual Dates – Actual Starts and Actual Finishes of activities in the schedule.

Actual Finish – The date when the work represented by a specific activity in the schedule was actually finished.

Actual Start – The date when the work represented by a specific activity in the schedule was actually started.

Activity Network Diagram – A graphic representation of a CPM schedule that shows the relationships among activities.

Bar Chart – A graphic representation of a schedule without relationships. A timescale appears along the horizontal axis.

Baseline Schedule – The first accepted CPM schedule showing the accepted plan to complete the entire Project.

CPM of Record – The most recent CPM schedule accepted by the Engineer.

Calendar Day – A day shown on the calendar beginning and ending at midnight.

Constraint – A restriction imposed in a schedule, which fixes a value that would otherwise be calculated within the schedule. Examples of values that can be fixed by a constraint include float, start date, end date, and completion date.

Contract Time – The number of calendar days inclusive between the Notice to Proceed and the Contract Completion Date.

Contract Value – The Contract Lump Sum Price and any additional dollar value added through Supplemental Agreement(s).

Controlling Activity – The first incomplete activity on the Critical Path. This term is considered synonymous with “Controlling Operation.”

Critical Delay – A delay to an activity on the critical path that extends the Scheduled Completion Date.

Critical Path – The longest path of activities that determines the scheduled completion date of the Project. Activities on the critical path are critical activities.

Data Date – The earliest possible date identified in a schedule from which remaining activities can proceed.

Early Finish – The earliest date an activity can finish based on its duration and its predecessors.

Early Start – The earliest date an activity can start based on its predecessors.

Final Schedule – The last monthly update CPM schedule containing actual start and finish dates for every activity.

Free Float – The amount of time an activity can be delayed without delaying the early start date of any successor activity.

Lag – An offset of time from the predecessor to the successor. Lag is a numerical value that is not assigned a description or activity number.

Late Finish – The latest date an activity can finish based on its successors without causing a delay to the Scheduled Completion Date of the Project.

Late Start – The latest date an activity can start based on its successors and duration without causing a delay to the Scheduled Completion Date of the Project.

Logic – Plural or singular reference to the predecessor and successor relationships between activities in the schedule.

Milestone – An activity with no duration that is typically used to represent the beginning or end of the project or an interim phase. Includes, but is not limited to, Intermediate Completion Dates and the Contract Completion Date.

Open End – The condition that exists when an activity has either no predecessor or no successor, or when an activity's only predecessor relationship is a finish-to-finish or only successor relationship is a start-to-start.

Original Duration – The original estimate of time, expressed in workdays, required to perform an activity.

Preceding Work – Work that must be performed prior to work being performed on the same project by other Contractors or Design-Build Teams and under separate contract with the NCTA.

Predecessor – An activity that is defined by schedule logic to precede another activity.

Progress Schedule – A CPM schedule produced by incorporating the Project's actual progress into the CPM of Record for purposes of reviewing payment applications prior to any major schedule revisions.

Punch Work – Minor corrective work typically performed at the end of construction that is necessary to bring the Project into full compliance with the requirements of the Contract.

Relationship – Interdependence between two activities. Relationships link an activity to predecessors and successors.

Remaining Duration – The estimated time, expressed in workdays, required to complete an activity.

Revised Schedule – A Progress Schedule with Schedule Revisions.

Scheduled Completion Date – The completion date forecast by the CPM schedule. The schedule may also forecast Intermediate Completion Dates for Milestones, Phases, or other portions of the Project.

Schedule Revision(s) – A change in calendars, along with adding/deleting activities, the method of calculation, relationships, sequence, or original duration of activities in the schedule; or a change in the remaining duration of a work activity that is not caused by the actual progress of the activity. Revisions can be considered either Major or Minor as noted in Article 108-2 Section F of this Standard Special Provision.

Successor – An activity that is defined by schedule logic to succeed another activity.

Total Float – The amount of time an activity can be delayed without affecting the completion date of the project or an intermediate deadline (constraint); it is the difference between the late finish date and the early finish date.

(B) Design-Build Team's Scheduling Representative

The Design-Build Team shall propose to NCTA a person to serve as the Schedule Representative responsible for developing, updating, and revising the Design-Build Team's CPM. The Design-Build Team shall propose a Schedule Representative with experience on

projects of similar size, scope and complexity. The Schedule Representative shall have project management experience and responsibility for the project's budget/invoicing. The Schedule Representative may also serve as the project manager, so long as all the requirements of this Provision can still be met. The proposed Schedule Representative's qualifications shall be submitted with the Technical Proposals for NCTA evaluation. The Engineer may reject a Scheduling Representative that does not meet the minimum requirements of this Provision. In such case, the Design-Team must designate another individual meeting the minimum requirements for a Scheduling Representative prior to the acceptance of the Initial CPM.

The Design-Build Team shall authorize the Schedule Representative to certify schedules, answer schedule-related questions, and propose revisions to the schedule as necessary to present a current and reliable plan of construction. The Schedule Representative shall be authorized to speak on behalf of the Design-Build Team in matters related to scheduling and budgeting of the Work. The Schedule Representative shall attend all scheduling and progress meetings including, but not limited to, the Design-Build Team's schedule meetings with subcontractors, vendors, utility companies, or other government agencies. The Design Build Team shall use the same Schedule Representative for the duration of the project unless submitted and approved by the Department in writing. If the accepted Schedule Representative is no longer assigned to the Project, the Design-Build Team shall submit a new Schedule Representative for the Engineer's review within 14 days of receiving notice of the Schedule Representative's departure.

(C) Interim Schedule

The Design-Build Team may submit electronically to NCTA a cost-loaded Interim Critical Path Method Project Schedule (Interim Schedule). The Interim Schedule shall be submitted electronically to the NCTA within 7 days of the Notice to Proceed, whether limited or unlimited. The NCTA will use the Interim Schedule to monitor the progress of the Project and process the Design-Build Team's payment applications for up to 90 days from the Notice to Proceed. The use of an Interim Schedule in lieu of an Initial Cost-Loaded Critical Path Method schedule is optional.

The Interim Schedule shall meet the following requirements:

- (1) The Interim Schedule will start with an activity identified as "Notice to Proceed." The Design-Build Team shall constrain "Notice to Proceed" to start on the expected date of the Notice to Proceed. The schedule shall include an activity for both the limited and unlimited Notice to Proceeds.
- (2) The last activity in the Interim Schedule will be identified as "Project Completion." The Design-Build Team shall plan the other activities in the schedule so that the late finish date of "Project Completion" is calculated to occur on the Contract Completion Date.
- (3) The Design-Build Team shall identify all major components of Work in the Interim Schedule as activities. For the Interim Schedule, the Design-Build Team may present large components of the Work, such as "construction of the Project," as a single activity

in the schedule, so long as the Interim schedule meets the other requirements of this Provision.

The Design-Build Team shall identify the following for each activity in the Interim Schedule.

- (a) A unique alphanumeric activity ID
 - (b) A description of the work associated with each activity ID
 - (c) A duration
 - (i) The Design-Build Team shall limit activities expected to start in the first 90 days to a maximum duration of 20 work days. The Design-Build Team shall subdivide activities expected to take longer than 20 days so as to provide more detail and to meet this requirement. Any duration provided by NCTA, utilities, or other government agencies will be exempt from this requirement.
 - (ii) The Design-Build Team may assign any realistic durations for activities expected to start more than 90-days after Notice to Proceed.
 - (d) Predecessors
 - (e) Successors
 - (f) Value of the Work
 - (i) The Design-Build Team shall assign an accurate dollar value to each activity expected to start within 90 days of Notice to Proceed based on estimated costs plus associated profit and overhead. The profit and overhead assigned by the Design-Build Team to the individual activities starting in the first 90 days shall be equal to or less than the mark-up applied to the Work when establishing the Contract Lump Sum Price.
 - (ii) The Design-Build Team shall limit the value of an activity to \$500,000 for activities expected to start in the first 90 days. The Design-Build team shall subdivide activities starting in the first 90 days and with anticipated values over \$500,000 into 2 or more activities to meet this requirement.
 - (iii) The Design-Build Team shall assign a dollar value to each activity in the Interim Schedule.
 - (iv) Activities may be assigned a value of zero dollars, as appropriate.
 - (v) The total value of all activities in the Interim Schedule shall be equal to the Contract Lump Sum Price.
 - (vi) Any activities that are incidental will have a value of zero dollars.
- (4) The Design-Build Team shall assign each activity in the Interim Schedule at least one predecessor and one successor, except the first activity and the last activity in the schedule.
- (5) The Design-Build Team shall use scheduling software to calculate the following data for each activity in the schedule:
- (a) Early Start
 - (b) Early Finish
 - (c) Late Start

- (d) Late Finish
 - (e) Total Float
- (6) The Design-Build Team is not required to submit a written Narrative with the Interim Schedule. However, NCTA will accept and review written narratives as part of its technical assessment of the Design-Build Team's plan of construction. The Design-Build Team's written narrative should explain the planned sequence of work, the critical path, proposed phasing of the Project, and any other scheduling assumptions made by the Design-Build Team.

The Engineer may choose to reject the Interim Schedule if it does not conform to the requirements of this Provision. If the Engineer rejects the Interim Schedule, the Project will be administered as if no Interim Schedule had been submitted.

(D) Initial Cost-Loaded Critical Path Method Schedule (ICPM)

Within 30 days of limited or unlimited Notice to Proceed, the Design-Build Team shall submit electronically to the Engineer an Initial Cost-Loaded Critical Path Method Project Schedule (ICPM) meeting the requirements of this Provision and using industry-accepted CPM scheduling practices as identified in the AGC's Construction Planning and Scheduling book, Second Edition. Within 21 days of the receipt of the Design Build Team's Initial Schedule, the Engineer will complete the review of the ICPM. If the Engineer decides it is warranted, the Engineer will convene a joint review conference at which the Engineer and the Design-Build Team will make any necessary corrections or adjustments to the ICPM. If a revision is necessary either from the Engineer's Review or the joint review conference, the Design-Build Team shall submit a revised ICPM electronically within 7 days of such joint review conference and the Engineer will review the revised ICPM within 7 days of re-submittal. The Design Build Team and the Engineer will repeat this process until an acceptable ICPM is established.

Once the ICPM has been accepted, it becomes the baseline schedule for the Project and the first CPM of Record for the Project. If an Interim Schedule was submitted and accepted by the Engineer, the accepted ICPM replaces the Interim Schedule for all purposes, including payment.

The Design-Build Team shall submit an ICPM that meets the following requirements.

- (1) The first activity in the schedule is "Notice to Proceed." The Design-Build Team shall constrain this activity to start on the date of the Notice to Proceed. Except as otherwise indicated in this Provision or agreed in writing by the Engineer, the Design-Build Team shall not use constraints. If at any time the Engineer approves the use of a constraint, the Design-Build Team shall provide written documentation of such to the NCTA.
- (2) The schedule shall include an activity identified as Substantial Completion.
- (3) The Last Activity in the Schedule shall be identified as "Project Completion." The Design-Build Team shall plan the other activities in the schedule so that the expected finish of "Project Completion" is calculated to occur on the Contract Completion Date.

- (4) The Design-Build Team shall plan its Work to meet all time-related requirements of the Contract. This includes but is not limited to: submittal review times, Milestones, Intermediate Contract Times, phasing requirements, and the date of Substantial Completion. The Design-Build Team shall include activities, within their CPM schedule, which represent reasonable durations for construction impacts or operations created by the Toll Integration Contractor performing their operations concurrently with the Design-Build Team's Work.
- (5) The Design-Build Team shall include within the ICPM work activities that must be performed prior to work being performed on the same project by other Contractors or Design-Build Teams and under separate contract with the NCTA (Preceding Work). Each activity that is considered Preceding Work shall have a responsibility code assigned.
- (6) The Design-Build Team shall identify all the components of the Work and the work of others on the Project as activities in the ICPM. If the Engineer cannot identify an item of the Work as an activity or as part of an activity in the schedule, then that item of the Work will be considered incidental.
- (7) The Design-Build Team shall designate the following for each activity in the ICPM, including:
 - (a) A unique alpha numeric activity ID
 - (b) A description of the work associated with each activity ID
 - (c) A duration
 - (i) The Design-Build Team shall limit construction activities to a maximum duration of 20 work days. The Design-Build Team shall subdivide activities expected to take longer than 20 days so as to provide more detail and to meet this requirement. If for any reason this requirement cannot be achieved, the Design-Build Team shall provide a written request to the Engineer, explaining the reasoning for the need to have a duration over 20 work days. Upon approval, the Design-Build Team shall forward the request to the NCTA. Any duration provided by NCTA, utilities, or other government agencies shall be exempt from this requirement. Waiting times for plant growth cure times, material procurement, and other activities assigned a zero dollar value and no assignment of responsibility are also exempt from this requirement.
 - (ii) The Design-Build Team shall limit design activities to the required design submittal intervals or a maximum of 90 days, whichever is shorter. The Design-Build Team shall subdivide activities expected to take longer so as to provide more detail.
 - (iii) All activities with a dollar value greater than zero shall have a duration assigned to it, even if the duration is equal to zero.
 - (d) Predecessors – Each activity except for “Notice to Proceed” shall have at least one predecessor.

- (e) Successors – Each activity except for “Final Completion” shall have at least one successor.
- (f) Activity Calendar – The Activity Calendar shall clearly identify the days when work could be performed on the activity and the days when work cannot be performed on the activity, in addition to the amount of hours per day for a given work week. Weather days shall be included as non-work days in specific work type calendars. Weather calendars should be agreed to by the Engineer. Weather should not be accounted for in activity durations.
- (g) Activity Code – Each activity in the schedule shall be assigned an activity code for the following categories:
 - (i) Area of the Project
 - (ii) Structure within the Area of the Project
 - (iii) Phase of the Project
 - (iv) Work Type
 - (v) Responsibility for the Work
 - The Design-Build Team shall identify the entity responsible to perform each activity in the schedule. Examples might include a particular subcontractor, NCTA, the Design-Build Team, a design consultant, a utility company, etc.
 - If more than one entity is performing a particular activity, then the activity code shall identify both entities.
 - When the ICPM is submitted, the Design-Build Team shall provide a list to the Engineer of each activity code that assigns responsibility to entities that are not under the control of the Design-Build Team.
 - (vi) Categories and Groupings
 - The Design-Build Team shall assign different categories for items in separate Divisions within the NCDOT Standard Specifications for Roads and Structures and at least one type of work shall be classified as punch work.
 - The Design-Build Team shall choose a method of identifying the type of work that shall clearly communicate to the Engineer the nature of the work being performed.
- (h) Value of the Work
 - (i) The Design-Build Team shall assign an accurate dollar value to each activity based on a reasonable assignment of the value of that work when compared to the overall work being performed on the Project.
 - (ii) The Design-Build Team shall not assign a dollar value to an activity less than the estimated cost to perform that work.
 - (iii) The Design-Build Team shall not assign a dollar value to the work being performed by NCTA or other third parties.
 - (iv) Activities scheduled to occur early in the Project shall be assigned the same or lesser value than similar activities scheduled to occur later in the Project, unless otherwise approved.

- (v) The Design-Build Team shall limit the value of an activity to \$500,000. The Design-Build team shall subdivide activities with anticipated values over \$500,000 into 2 or more activities to meet this requirement. Mobilization, some design activities, and materials procurement activities are exempt from this \$500,000 requirement.
 - (vi) The Design-Build Team shall assign activities in the schedule representing tasks incidental to the performance of the Work a value of zero dollars.
 - (vii) Activities may be assigned a value of zero dollars when appropriate. Examples include the work of others, or tasks performed by subcontractors for which the contractor has no cost.
 - (viii) Each Activity in the Schedule shall be cost loaded so that the sum of the budgeted total costs for each activity equals to the Total Contract Value. The budgeted total costs for each activity shall not change once the ICPM is approved as the First Schedule of Record, unless authorized in writing by NCTA.
 - (ix) Any work performed that is not identified in the schedule will have a value of zero dollars.
 - (x) Any activities that are incidental will have a value of zero dollars.
 - (xi) The Design-Build Team shall be limited to six percent of the total amount bid for the entire Project for "Mobilization" as detailed in the Project Special Provisions.
 - (xii) The Design-Build Team shall assign activities to both erosion and sedimentation control device installation and device maintenance. The activity for erosion and sedimentation control device maintenance shall span the duration of the contract and shall be cost-loaded in a linear manner.
 - (xiii) The Design-Build Team shall assign at least one-half of one percent of the total amount bid for the entire Project to the activity or activities representing punch work.
 - (xiv) All costs assigned to activities will be evaluated on a linear basis with regard to payment unless a payment curve is provided and approved. Such curves shall be agreed to in the baseline schedule and will not change unless authorized in writing by NCTA.
- (8) The Design-Build Team shall assign each activity in the ICPM at least one predecessor and one successor, except the first activity, "Notice to Proceed," and the last activity, "Project Completion."
- (9) The Design-Build Team shall not use start-to-finish relationships to connect predecessor and successor activities.
- (10) The Design-Build Team shall limit the use of start-to-start and finish-to-finish relationships to connect predecessor and successor activities. The Schedule Representative shall explain to the Engineer why a start-to-start or finish-to-finish relationship was used upon the Engineer's request. This information shall also be forwarded to the NCTA.
- (11) The Design-Build Team shall produce a schedule that does not contain open-ended activities, except for the first and last activity in the schedule.

- (12) The Design Team shall not use negative lags in the schedule. The Design-Build Team shall limit the use of lags in the schedule and shall not use a lag greater than 5 days. The Schedule Representative shall explain to the Engineer why a lag was used. This information shall also be forwarded to the NCTA.

The Design-Build Team shall use the scheduling software to calculate the following data for each activity in the schedule:

- (a) Early Start
- (b) Early Finish
- (c) Late Start
- (d) Late Finish
- (e) Total Float
- (f) Free Float

- (13) The longest path shall be dictated by schedule logic and durations, not by the leveling of resources or cost information.
- (14) The Design-Build Team shall be required to submit a written narrative with the ICPM. The Design-Build Team shall explain in its written narrative the planned sequence of the Work, the critical path, proposed phasing for the Project, the activity calendars, maintenance of traffic, milestone dates, labor and equipment resources, and the estimated payouts by month and by phase. In addition, the Design-Build Team shall explain in its written narrative how it has provided for procurement of materials, weather, permitting requirements, environmental requirements, coordination with other contractors, coordination with local municipalities, coordination with Toll Integration Contractor, coordination with NCTA's right of way Agent, work to be performed in whole or in part by Department or other government agencies, work to be performed by the utility companies, and any other scheduling assumptions made by the Design-Build Team.

The Engineer will review the ICPM submitted by the Design-Build Team for compliance with the requirements of the Contract. The Engineer may reject the ICPM if it does not adhere to the requirements of the Contract. The Engineer may reject the ICPM if it makes unreasonable demands on the Department or third parties on the Project without their written acknowledgement or agreement to such demands or requirements. Examples of unreasonable demands might include the simultaneous review of numerous submittals, short durations for utilities to perform work, shutting down adjacent roadways, or limiting access to private land owners. The Engineer may reject a schedule that over-utilizes start-to-start and finish-to-finish relationships to connect predecessor and successor activities if, in the opinion of the Engineer, the use of these logic relationships obscures the relationships between activities. The Engineer may reject a schedule that over-utilizes lags, if in the opinion of the Engineer, lags are being used to replace necessary activities or obscuring how one activity relates to the next.

The Engineer will also review the values assigned to the activities in the ICPM for balance. The Engineer may reject the ICPM if the dollar value assigned to any specific activity exceeds the Engineer's estimate by more than 40% or \$100,000. The Engineer may reject the ICPM if, in the opinion of the Engineer, the values assigned to activities expected to be

completed early in the Project exceed the value assigned to the same or similar activities expected to finish late in the Project, without explanation.

The Design-Build Team is responsible for the timely preparation of an ICPM that fully complies with the requirements of this Provision and the Contract. The Engineer may take action under Articles 108-7 and 108-9 of the 2018 NCDOT *Standard Specifications for Roads and Structures* if the Design-Build Team has not prepared an acceptable ICPM within 180 days from the Notice to Proceed.

(E) Schedule Updates

As the basis of its payment application request and as a requirement of this Provision, the Design-Build Team shall submit electronically to the Engineer a regular update to the CPM of Record using accepted scheduling practices. The Engineer will determine the frequency and date of the Schedule Updates – not to exceed two updates per month and to occur at least once within any 35 day period. The Design-Build Team shall continue to provide the Engineer schedule updates until the final schedule is approved with 100% completion of all activities and all the Work on the Project. The Design-Build Team shall submit a Schedule Update within 7 calendar days of its data date. The NCTA shall review the payment application and provide a response to the DBT within 7 calendar days of the submission. Upon the Engineer's acceptance, the Schedule Update will become the new CPM of Record, replacing the previous CPM of Record, and will be considered used from its data date until the data date of the next schedule accepted by the Engineer.

The Design-Build Team shall incorporate the following information into the previous CPM of record and submit this as its schedule update:

- (1) An updated data date
- (2) The actual start of any activity that started prior to the data date of the Schedule Update
- (3) The actual finish of any activity that finished prior to the data date of the Schedule Update
- (4) The new remaining duration of any activity that began, but did not finish prior to the data date of the schedule update.
- (5) The percent complete for every activity in the schedule. The Design-Build Team shall use both activity percent complete and resource percent complete for activities representing the purchase of materials, and shall identify the resource percent complete of activities representing the purchase of materials for undelivered; delivered or fabricated; or installed material as 0%, 95% or 100% complete, respectively.
- (6) The Design-Build Team shall use the scheduling software to calculate the following data for each of the remaining activities in the Schedule Update:
 - (a) Early Start
 - (b) Early Finish
 - (c) Late Start
 - (d) Late Finish
 - (e) Total Float

(f) Free Float

The Design-Build Team shall provide a schedule update narrative as part of the Schedule Update, in addition to any of the other requirements identified in Article 109-4 of the Standard Special Provision, Division One for partial payment requests. The Design-Build Team shall include in the schedule update narrative a description of the Work performed during the update period; the status of any outstanding permits; the current critical path; any delays or disruptions experienced during the update period to Intermediate Contract Dates, Substantial Completion, and/or Final Completion; any change in planned manpower or equipment; any foreseeable delays or disruptions; and any “Minor Revisions” made during the update period that have previously been accepted by the Engineer. A discussion of delays in the Schedule Update’s narrative shall not constitute a written request for additional time or notice of intent to file a claim as required by the Contract.

The Design-Build Team shall not incorporate any revisions into a Schedule Update unless the revisions are minor and have been previously accepted by the Engineer. Any documentation regarding the Minor Revisions shall be submitted to the NCTA. The schedule update narrative shall include documentation of any revisions previously verbally approved by the Engineer.

If the Design-Build Team chooses to revise the CPM of Record, the revised schedule shall be submitted separately from and within 7 calendar days of the progressed schedule. The revised schedule shall have the same data date as the most recent Schedule of Record and reflect the progress achieved up to that point in time.

The Engineer may reject a Schedule Update that incorporates “Major Revisions” that were not previously accepted by the Engineer, may reject a schedule update that includes actual dates on or after the data date, and may reject a Schedule Update that records incomplete or incorrect information on the progress of the Work.

(F) Revisions to the CPM of Record

The Design-Build Team may revise the CPM of Record. A revision to the CPM of record is defined as one or more of the following:

- (1) A change in an activity’s calendar
- (2) A change in the original duration of an activity
- (3) An increase in the remaining duration of an activity
- (4) A change in the logic of the schedule
- (5) A change to any actual date previously recorded and provided to the Engineer
- (6) The deletion or addition of an activity
- (7) A change to, addition of, or deletion of a constraint
- (8) A change to, addition of, or deletion of an activity code
- (9) A change to an activity description
- (10) A change to the dollar value assigned to an activity
- (11) Any other change other than updating progress or recording actual dates.

A minor revision is defined as a revision that does not affect the critical path of the Work on the Project, does not affect work activities that may soon become critical, does not significantly affect third parties, does not significantly affect the Department, and does not

increase or lower the dollar values assigned to the activities in the schedule. For minor revisions, the Schedule Representative shall contact the Engineer and explain the revision. If the Engineer determines that the revision is minor, the Engineer can verbally accept the revision. The Design-Build Team shall incorporate revisions verbally accepted by the Engineer into the next Schedule Update. The Engineer's determination as to whether a revision is minor or major shall be final.

All revisions that are not minor revisions are major revisions. For major revisions, the Design-Build team shall submit to the Engineer a revised CPM that meets all the requirements of the ICPM and is updated to reflect current progress. The Design-Build Team shall submit any revised CPM within 7 days of its data date unless otherwise agreed by the Engineer. The Design-Build Team shall include a narrative with the revised CPM describing each revision and the reason for each revision. Every revision that was made to the revised schedule shall be listed in the narrative. The Design-Build Team shall also include in the narrative any foreseeable problems that may need to be overcome when implementing the revision. A discussion of delays and potential delays in the revised CPM's narrative shall not constitute a written request for additional time or satisfy any requirement for written notice to file a claim as required by the Contract.

If the Design-Build Team is re-allocating the dollar values assigned to activities, it shall include for the Engineer's review a list of the activities affected by the revision, a list of any new activities added or deleted, and the difference in dollar value assigned to each activity. For changed Work where the dollar value is disputed, the Design-Build Team shall assign dollar values to its work activities as directed by the Engineer, but shall include the designation "D-C" at the beginning of the activity's description for each activity affected by the change. For changes settled through a Supplemental Agreement, the Design-Build Team shall assign the agreed dollar amount among the new or existing activities, and shall include the designation SA# (where # represents the number of the Supplemental Agreement) at the beginning of the activity's description for each activity affected by the change.

Within 7 calendar days or submittal, the Engineer shall accept or reject proposed revision(s). Upon the Engineer's acceptance, the revised CPM will become the CPM of Record, and will be used from its data date until the data date of the next schedule accepted by the Engineer.

NCTA will not pay additional costs for revisions to the CPM regardless of what condition or change prompted the revision(s). The cost to create, revise, and update the CPM is an administrative requirement included as part of the Contract Lump Sum Price. The Design-Build Team shall allocate sufficient resources to timely administer the schedule as required.

The Engineer will accept revisions that appear to accurately reflect the Design-Build Team's current plan for completing the Work on the Project. The Engineer may accept a revised CPM that indicates the Project is currently expected to finish earlier or later than required by the Contract. However, the Engineer's acceptance of the Design-Build Teams' schedules does not relieve the Design-Build Team from its obligations to perform under the terms of the contract including completion of the Work within the contract time; or as granting, rejecting, or in any way acting on the Design-Build Team's requests for adjustment to the date for completion of the Work.

The Engineer may reject any revision that does not, in the opinion of the Engineer, accurately reflect the Design-Build Team's current plan of construction; the Engineer may reject any revision that requires additional or revised actions on the part of third parties or the Department; the Engineer may reject a revision that changes the dollar value assigned to an activity, unless the Design-Build Team has correctly allocated this amount into new activities for additional detail; the Engineer may reject any revision that materially alters the projected payout of the Project; and the Engineer may reject any revised CPM submitted more than 7 calendar days after its data date unless the Engineer had previously agreed to waive this requirement.

(G) Use of the CPM of Record to Assess Project Delays

If the Design-Build Team submits a written request for an extension to the contract time in accordance with Article 108-10 of Division One of the Standard Special Provisions, the Engineer will rely upon the CPM of Record in effect at the time the delay is recognized or occurs, whichever is sooner, to assess the effects of changes and revisions or other potential causes of delay to the Scheduled Completion Date.

For purposes of calculating and withholding anticipated liquidated damages as identified in the 2018 NCDOT *Standard Specifications for Roads and Structures*, and as may be amended by this Standard Special Provision, the Engineer will rely on the Scheduled Completion Date identified in the CPM of Record.

Page 1-69, delete Article 108-3 and replace with the following:

108-3 PRECONSTRUCTION AND PRE-DESIGN CONFERENCES

The selected Design-Build Team shall meet with the Engineer for a pre-design conference concerning the design phase of the work. This conference shall be held prior to the commencement of work, as it is determined according to Article 108-1, and will be scheduled by the Engineer. At the predesign conference, the Design-Build Team shall furnish authorized signature forms and a list of any proposed subcontractors associated with the design of the project.

A preconstruction conference shall be held at least ten working days before construction activity begins. This second conference, concerning the construction phase, shall also be scheduled by the Engineer. The Design-Build Team shall give the Engineer a minimum of 45 days notice before he plans to begin construction activities. This will allow the Engineer time for any environmental agency representatives involved in the permitting process, as well as any other pertinent entities, to be scheduled to attend the preconstruction conference. If the Design-Build Team is responsible for utilities in accordance with Article 105-8 and the Request for Proposals, he shall be responsible for coordinating with the Engineer in scheduling their attendance and for notifying them. The Design-Build Team shall also be responsible for coordinating with the Engineer in scheduling the attendance of subcontractors and others deemed appropriate, and for notifying them.

At the preconstruction conference, a list of any proposed subcontractors and major material suppliers associated with the construction of the project will be submitted.

If the contract has a DBE requirement, the Design-Build Team shall submit copies of completed and signed DBE subcontracts, purchase orders, or invoices to the Department.

The Design-Build Team shall submit a traffic control plan in accordance with Article 1101-5 and the Request for Proposals. The Design-Build Team shall designate an employee who is competent and experienced in traffic control to implement and monitor the traffic control plan. The qualifications of the designated employee must be satisfactory to the Engineer.

The Design-Build Team shall submit a safety plan and designate an employee as Safety Supervisor.

Both plans shall be submitted at the preconstruction conference and must be satisfactory to the Engineer. Should the design plan include activities that would place personnel on the work site, traffic control and safety plans for those activities shall be submitted at the predesign conference.

During the preconstruction conference, the Engineer will designate a Department employee or employees who will be responsible to see that the traffic control plans and any alterations thereto are implemented and monitored to the end that traffic is carried through the work in an effective manner. If approved by the Engineer, the Design-Build Team may designate one employee to be responsible for both the traffic control and safety plans. The Design-Build Team shall not designate its superintendent as the responsible person for either the traffic control plan or the safety plan, unless approved by the Engineer.

If the project requires that Design-Build Team or State personnel work from falsework, within shoring, or in any other hazardous area the Design-Build Team shall submit, as part of the Design-Build Team's safety plan, specific measures it will use to ensure worker safety.

The Design-Build Team shall also submit a program for erosion control and pollution prevention on all projects involving clearing and grubbing, earthwork, structural work, or other construction, when such work is likely to create erosion or pollution problems.

If the Design-Build Team fails to provide the required submissions, the Engineer may order the preconstruction conference suspended until such time as they are furnished. Work shall not begin until the preconstruction conference has been concluded and the safety plan has been approved, unless authorized by the Engineer. The Design-Build Team shall not be entitled to additional compensation or an extension of contract time resulting from any delays due to such a suspension.

The Design-Build Team shall designate a qualified employee as Quality Control Manager. The Quality Control Manager shall be responsible for implementing and monitoring the quality control requirements of the project.

Page 1-69, Article 108-4, add the following sentence to the end of this article:

The Design-Build Team shall record the proceedings of these conferences and distribute the final minutes of the conferences to all attendees.

Page 1-70, Article 108-6, replace “40%” with “30%” in the 1st paragraph.

Page 1-71, Article 108-6, replace “35%” with “25%” in the 2nd paragraph.

Pages 1-72, delete Article 108-8 and replace with the following:

108-8 FAILURE TO MAINTAIN SATISFACTORY PROGRESS

The Engineer will utilize the Cost-Loaded Critical Path Method Project Schedule to evaluate the Design-Build Team's progress at the time each partial pay request and schedule update is submitted. The Design-Build Team's progress may be considered as unsatisfactory if, according to the CPM Schedule of Record, the Scheduled Completion Date exceeds the Contract Completion Date.

When the Design-Build Team's progress is found to be unsatisfactory as described above, the Engineer may make written demand of the Design-Build Team to state in writing the reason for the unsatisfactory progress and produce such supporting data as the Engineer may require or the Design-Build Team may desire to submit. The Engineer will consider the justifications submitted by the Design-Build Team and extensions of the completion date that have or may be allowed in accordance with Article 108-10 of this Standard Special Provision.

When the Design-Build Team cannot satisfactorily justify the unsatisfactory progress the Engineer may invoke one or more of the following sanctions:

1. Withhold anticipated liquidated damages from amounts currently due or which become due.
2. Remove the Design-Build Team and individual managing firms of the Design-Build Team and/or prequalified design firms from the Department's Prequalified Bidders List.

When any of the above sanctions have been invoked, they shall remain in effect until rescinded by the Engineer.

Page 1-74, Article 108-10, replace the entire article with the following:

108-10 CONTRACT TIME; INTERMEDIATE CONTRACT TIME**(A) General**

The contract time will be as defined in Section 101 of this Standard Special Provision. No extensions to the completion date will be authorized except as allowed by this article. No modifications in the date of availability will be made for any reason whatsoever.

Intermediate contract time, as defined in Section 101 of this Standard Special Provision will be that as allowed in the contract to complete a part, portion, or phase of the total work covered in the contract. Intermediate completion dates and intermediate completion times set forth in the contract may be extended on the same basis as completion dates and as described in this article.

When the liquidated damages stipulated in the contract are to be on an hourly basis, extensions as described in this article will be considered on an hourly basis.

The Engineer will rely upon the CPM of Record in effect at the time the delay is recognized or occurs, whichever is earlier, to assess the effects of changes and revisions or other potential causes of delay to the Scheduled Completion Date.

The Engineer will use the CPM and the following guidelines to assess delays to the Project:

- (1) The controlling operation of the Work is the first activity on the critical path of the CPM of Record.
- (2) The Engineer will not grant a time extension for delays that result from schedule revisions of any sort, unless the revisions are necessary to mitigate unforeseeable and otherwise excusable delays, the revisions are required to incorporate changes to the Work agreed to by the Engineer, or the revisions are expressly requested by the Engineer to accommodate NCTA.
- (3) The Design-Build Team creates the CPM and is responsible for the accuracy and reliability of the CPM. The Engineer will not grant a time extension for delays that result from improper planning, incorrect sequences, scheduling errors, scheduling omissions, missing portions of the Work in the schedule, or any other cause related to the Design-Build Team's failure to properly manage and schedule the Work or the work of others. The Engineer will not consider a request for additional time from the Design-Build Team that relies on the assumption that the CPM of Record was inaccurate or erroneous.
- (4) When there are two or more causes for a critical delay, or in the case that two paths of activities are concurrently critical, the Engineer will only grant a time extension if all the causes for the critical delay are determined to be excusable.
- (5) The critical path is dynamic. The Engineer will assess the critical path on each day of an alleged delay. Only delays to the critical path will be eligible for consideration of a time extension.
- (6) The Engineer will use the CPM of Record in effect at the time of the delay to assess Project delays after the occurrence. The Engineer will not use rejected schedules, later approved schedules, or new schedules, including "impacted" or "collapsed schedules" to assess a delay to the Project after the alleged delay has occurred.
- (7) Float belongs to the Project and is shared between the Design-Build Team and NCTA on a first-come, first-served basis until it is depleted. Float is not for the exclusive use or benefit of either the NCTA or the DB Team.

(B) Completion Date, Intermediate Completion Date, and Intermediate Completion Time Extensions

Only delays to activities which affect the completion date or intermediate contract date will be considered for an extension of contract time. No extensions will be granted until a delay occurs which impacts the project's critical path, consumes all available float, and extends the work beyond the contract completion date or intermediate completion date. Any extension to the completion date or intermediate contract date will be based on the number of calendar days the completion date or intermediate completion date is impacted as determined by the Engineer's analysis. No extension of the completion date, intermediate completion date, or intermediate completion time will be allowed for any reason except as provided for below:

- (1) If the Design-Build Team's current controlling operation(s) are delayed by circumstances originating from work required under the contract and beyond his control

and without his fault or negligence, he may, at any time prior to payment of the final estimate, make a written request to the Engineer for an extension of the completion date, intermediate completion date, or intermediate completion time. This request shall include:

- (a) the circumstances resulting in the alleged delay and documentation of said circumstances as may be required by the Engineer,
- (b) the controlling operation(s) alleged to have been delayed,
- (c) the calendar dates or calendar dates and times on which the controlling operation(s) were delayed and
- (d) the number of calendar days or hours by which he is requesting the completion date, intermediate completion date, or intermediate completion time to be extended.

If the Engineer determines that the controlling operation(s) were delayed because of circumstances beyond the control of and without the fault or negligence of the Design-Build Team, and that the Design-Build Team has pursued the work in accordance with Article 108-1, he will extend the completion date, intermediate completion date, or intermediate completion time unless otherwise precluded by other provisions of the contract. No extension of the completion date, intermediate completion date, or intermediate completion time will be allowed for delays caused by restrictions, limitations or provisions contained in the contract.

Consideration will be given for an extension in the completion date, intermediate completion date, or intermediate completion time involving an intermediate contract time of more than 96 hours if the Design-Build Team's current controlling operation(s) is delayed in excess of 8 percent of the total contract time (days), as defined in Section 101, the total intermediate contract time (days), as defined in Section 101, or the total intermediate contract time (hours), as defined in Section 101; due to weather or conditions resulting from weather. No other consideration will be given for extensions in the completion date, intermediate completion date, or intermediate completion time due to delays caused by weather.

Where the intermediate contract time is 96 hours or less, no consideration whatsoever will be given for an extension in the intermediate completion time due to weather or conditions resulting from weather.

- (2) If changes in the work from that originally contemplated in the contract are ordered by the Engineer and these changes result in reduction in quantities, elimination of items, additional work and/or extra work, the Engineer will allow an extension in the completion date, intermediate completion date, or intermediate completion time as he may deem warranted by such changes. Pursuit of the work with adequate forces and equipment and efficiency of the Design-Build Team's operations will be considered by the Engineer in determining an extension in the completion date, intermediate completion date, or intermediate completion time. It is, however, the Design-Build Team's responsibility to show just cause for an extension in the completion date,

intermediate completion date, or intermediate completion time due to the aforesaid conditions.

The Design-Build Team's plea that insufficient contract time (days), intermediate contract time (days), or intermediate contract time (hours) was specified in the contract will not be considered as a valid reason for an extension in the completion date, intermediate completion date, or intermediate completion time.

When all work on the project is totally complete, with the exception of an item or items on which work is precluded by seasonal limitations set forth in the contract, the Engineer may, provided that the Design-Build Team has diligently pursued the work with adequate forces and equipment, waive the assessment of liquidated damages during the period of time from the date all work other than that precluded by seasonal limitations was completed until the date of expiration of the seasonal limitations. The Design-Build Team shall make the request to waive the assessment of liquidated damages in writing prior to the beginning date of the requested waiver. The non-assessment of liquidated damages during the aforesaid period shall not operate to waive any other liquidated damages that may be assessable or any other terms of the contract.

Page 1-78, Article 108-13, delete bullet (D)(2) in its entirety.

SECTION 109 MEASUREMENT AND PAYMENT

Page 1-80, Article 109-2, delete the last sentence of the 1st paragraph and replace with the following:

Payment to the Design-Build Team will be made only for the work completed, certified and accepted in accordance with the terms of the contract.

Pages 1-85, delete Article 109-4(A) and replace with the following:

109-4 PARTIAL PAYMENTS

(A) General:

Partial payments will be based upon the Engineer's review of the Design-Build Team's payment requests. The Design-Build Team will prepare a payment request at least once each month on the date established by the Engineer. Partial payments may be made twice each month if in the judgment of the Engineer the amount of work performed is sufficient to warrant such payment. No partial payment will be made when the total value of work performed since the last partial payment, excluding mobilization, amounts to less than \$10,000.00. Partial payments will be approximate only and will be subject to correction in the final estimate and payment.

The Design-Build team shall use the most recent accepted cost-loaded CPM to estimate the value of the work performed and will submit this estimate as its payment request to the Engineer. The Design-Build Team shall submit the estimate of the value of the Work performed and the updated cost-loaded Schedule for each partial payment request.

Failure to submit either part of the partial payment request will result in the Engineer withholding payment. With each payment request, the Design-Build Team shall certify that it has reviewed the cost-loaded CPM, that the payment request presents an accurate assessment of the level of completion of each work activity for which payment is being sought, and that the dollar value assigned to each work activity is reasonable and consistent with the dollar values assigned to all other work activities. The Engineer will only accept payment requests that have been certified by the Design-Build Team.

The Design-Build Team will maintain and update the cost-loaded CPM as further described in Article 108-2 of this Special Provision.

If an Interim Schedule was submitted in accordance with Article 108-2 of this Standard Special Provision and this Schedule was accepted by the Engineer, the Design-Build Team may estimate the value of the work performed using the Interim Schedule for the first 90 days after the Notice of Proceed. After 90 days, the Engineer will not process partial payment requests until the Design-Build Team develops a cost-loaded, initial CPM and the Engineer accepts this schedule.

If the Design Build Team did not submit an Interim Schedule acceptable to the Engineer, NCTA will issue payments for the mobilization costs (reference Article 800-2 of the Standard Specifications and the Project Special Provision, Mobilization), but will not otherwise process partial payment requests until the Design-Build Team submits a cost-loaded, Initial CPM and this CPM is accepted by the Engineer. The Design-Build Team's failure to develop an acceptable, cost-loaded Initial CPM may result in the Engineer withholding payment.

Interest will not be paid to the Design-Build Team on payments that are withheld in accordance with the requirements of this Special Provision or any other provision of the contract. The Design-Build Team is not entitled to payment, damages, or any other form of compensation due to the withholding of partial payments in accordance with the requirements of this Special Provision or any other provision of the contract.

The Engineer will withhold an amount sufficient to cover anticipated liquidated damages as determined by the Engineer.

Page 1-86, Subarticle 109-5(D), delete the 4th and 5th paragraphs and replace with the following:

Partial payments will not be made on seed or any living or perishable plant materials.

Partial payment requests shall not be submitted by the Design-Build Team until those items requested have corresponding signed and sealed RFC plans accepted by the Department.

Page 1-88, Article 109-10, replace the first paragraph with the following:

Submit the following documents to the Engineer within 120 days after the contract Final Acceptance Date, as defined in Article 101-3 of the 2018 NCDOT *Standard Specifications for Roads and Structures*, and as may be amended in this Standard Special Provision. Failure to submit the notice required by Subarticle 109-10(C) of the 2018 NCDOT *Standard Specifications for Roads and Structures*, the final claim information, within the 120 days

after the Final Acceptance Date, shall be a bar to recovery for any extension in the completion date or any adjustment in compensation from that shown in the final estimate.

Page 1-88, Article 109-10, add the following as bullets (E) and (F) under the 1st paragraph.

- (E) As-Constructed Drawings, As-Built Plans and other documents required elsewhere in this RFP.
- (F) Documents or guarantees to support any warranty provided by the Design Build Team.

County : Wake

Line #	Item Number	Sec #	Description	Quantity	Unit Cost	Amount
--------	-------------	-------	-------------	----------	-----------	--------

ROADWAY ITEMS

0001	0000900000-N	SP	GENERIC MISCELLANEOUS ITEM DESIGN AND CONSTRUCTION	Lump Sum	L.S.	
------	--------------	----	---	----------	------	--

1238/Aug10/Q1.0/D900000/E1

Total Amount Of Bid For Entire Project :

FUEL USAGE FACTOR CHART AND ESTIMATE OF QUANTITIES

Description of Work	Units	Fuel Usage Factor Diesel #2	Estimate of Quantities
Unclassified Excavation	Gal / CY	0.29	_____ CY
Borrow Excavation	Gal / CY	0.29	_____ CY
Class IV Subgrade Stabilization			
Aggregate Base Course	Gal / Ton	0.55	_____ Tons
Sub-Ballast			
Aggregate for Cement Treated Base Course			
Portland Cement for Cement Treated Base Course	Gal / Ton	0.55	_____ Tons
Asphalt Concrete Base Course	Gal / Ton	2.90	_____ Tons
Asphalt Concrete Intermediate Course			
Asphalt Concrete Surface Course			
Open-Graded Asphalt Friction Course			
Permeable Asphalt Drainage Course			
Sand Asphalt Surface Course, Type SA-1			
Portland Cement Concrete Pavement:			
Thru Lanes and Shoulders (> 11")	Gal / SY	0.327	_____ SY
Thru Lanes and Shoulders (9" to 11")		0.272	_____ SY
Thru Lanes and Shoulders (< 9")		0.245	_____ SY
* Structural Concrete (Cast-in-Place Only)	Gal / CY	0.98	_____ CY

* Structural Concrete shall be defined as cast-in-place Class A or Class AA concrete used in the construction of major structures for various work items identified in Division 4 of the 2018 *Standard Specifications for Roads and Structures*.

The above quantities represent a reasonable estimate of the total quantities anticipated, for each item, as pertaining to fuel price adjustments, and is representative of the design proposed in the Technical Proposal submitted under separate cover.

Or

The Design-Build Team elects not to pursue reimbursement for Fuel Price Adjustments on this project.

The information submitted on this sheet is claimed as a "Trade Secret" in accordance with the requirements of G.S. 66-152(3) until such time as the Price Proposal is opened.

Signature, Title

Dated

Print Name, Title

(Submit a copy of this sheet in a separate sealed package with the outer wrapping clearly marked "Fuel Price Adjustment" and deliver with the submission of the Technical Proposal.)

LISTING OF DBE SUBCONTRACTORS

Sheet _____ of _____

Firm Name and Address	Item No.	Item Description	* Agreed upon Unit Price	** Dollar Volume of Item
Name Address				
Name Address				
Name Address				
Name Address				
Name Address				
Name Address				
Name Address				

This form must be completed in order for the Bid to be considered responsive and be publicly read. Bidders with no DBE participation must so indicate this on the form by entering the word or number *zero*.

LISTING OF DBE SUBCONTRACTORS

Sheet _____ of _____

Firm Name and Address	Item No.	Item Description	* Agreed upon Unit Price	** Dollar Volume of Item
Name Address				
Name Address				
Name Address				
Name Address				
Name Address				
Name Address				
Name Address				

This form must be completed in order for the Bid to be considered responsive and be publicly read. Bidders with no DBE participation must so indicate this on the form by entering the word or number *zero*.

LISTING OF DBE SUBCONTRACTORS

Sheet _____ of _____

Firm Name and Address	Item No.	Item Description	* Agreed upon Unit Price	** Dollar Volume of Item
Name Address				
Name Address				
Name Address				
Name Address				
Name Address				
Name Address				
Name Address				

This form must be completed in order for the Bid to be considered responsive and be publicly read. Bidders with no DBE participation must so indicate this on the form by entering the word or number *zero*.

LISTING OF DBE SUBCONTRACTORS

Sheet _____ of _____

Firm Name and Address	Item No.	Item Description	* Agreed upon Unit Price	** Dollar Volume of Item
Name Address				
Name Address				
Name Address				
Name Address				

COST OF CONSTRUCTION WORK ONLY

\$ _____

*The Dollar Volume shown in this column shall be the Actual Price Agreed Upon by the Prime Contractor and the DBE subcontractor, and these prices will be used to determine the percentage of the DBE participation in the contract.

** Dollar Volume of DBE Subcontractor \$ _____

Percentage of Total Construction Cost _____ %

(Including Right of Way Acquisition Services)

** - Must have entry even if figure to be entered is zero.

** - *If firm is a Material Supplier Only, show Dollar Volume as 60% of Agreed Upon Amount from Letter of Intent.
If firm is a Manufacturer, show Dollar Volume as 100% of Agreed Upon Amount from Letter of Intent.*

**This form must be completed in order for the Bid to be considered responsive and be publicly read.
Bidders with no DBE participation must so indicate this on the form by entering the word or number zero.**

**EXECUTION OF BID
NON-COLLUSION AFFIDAVIT, DEBARMENT CERTIFICATION AND GIFT BAN CERTIFICATION**

CORPORATION

The person executing the bid, on behalf of the Bidder, being duly sworn, solemnly swears (or affirms) that neither he, nor any official, agent or employee of the Bidder has entered into any agreement, participated in any collusion, or otherwise taken any action which is in restraint of free competitive bidding in connection with any bid or contract, that the Bidder has not been convicted of violating *N.C.G.S. § 133-24* within the last three years, and that the Bidder intends to do the work with its own bonafide employees or subcontractors and is not bidding for the benefit of another contractor.

In addition, execution of this bid in the proper manner also constitutes the Bidder's certification of status under penalty of perjury under the laws of the United States in accordance with the Debarment Certification attached, provided that the Debarment Certification also includes any required statements concerning exceptions that are applicable.

N.C.G.S. § 133-32 and Executive Order 24 prohibit the offer to, or acceptance by, any State Employee of any gift from anyone with a contract with the State, or from any person seeking to do business with the State. By execution of any response in this procurement, you attest, for your entire organization and its employees or agents, that you are not aware that any such gift has been offered, accepted, or promised by any employees of your organization.

SIGNATURE OF CONTRACTOR

Full name of Corporation

Address as prequalified

Attest _____
Secretary / Assistant Secretary
Select appropriate title

By _____
President / Vice President / Assistant Vice President
Select appropriate title

Print or type Signer's name

Print or type Signer's name

CORPORATE SEAL

**EXECUTION OF BID
NON-COLLUSION AFFIDAVIT, DEBARMENT CERTIFICATION AND GIFT BAN CERTIFICATION**

PARTNERSHIP

The person executing the bid, on behalf of the Bidder, being duly sworn, solemnly swears (or affirms) that neither he, nor any official, agent or employee of the bidder has entered into any agreement, participated in any collusion, or otherwise taken any action which is in restraint of free competitive bidding in connection with any bid or contract, that the bidder has not been convicted of violating *N.C.G.S. § 133-24* within the last three years, and that the Bidder intends to do the work with its own bonafide employees or subcontractors and is not bidding for the benefit of another contractor.

In addition, execution of this bid in the proper manner also constitutes the Bidder's certification of status under penalty of perjury under the laws of the United States in accordance with the Debarment Certification attached, provided that the Debarment Certification also includes any required statements concerning exceptions that are applicable.

N.C.G.S. § 133-32 and Executive Order 24 prohibit the offer to, or acceptance by, any State Employee of any gift from anyone with a contract with the State, or from any person seeking to do business with the State. By execution of any response in this procurement, you attest, for your entire organization and its employees or agents, that you are not aware that any such gift has been offered, accepted, or promised by any employees of your organization.

SIGNATURE OF CONTRACTOR

_____ Full Name of Partnership

_____ Address as Prequalified

_____ By _____
Signature of Witness Signature of Partner

_____ Print or type Signer's name

_____ Print or type Signer's name

**EXECUTION OF BID
NON-COLLUSION AFFIDAVIT, DEBARMENT CERTIFICATION AND GIFT BAN CERTIFICATION
LIMITED LIABILITY COMPANY**

The person executing the bid, on behalf of the Bidder, being duly sworn, solemnly swears (or affirms) that neither he, nor any official, agent or employee of the bidder has entered into any agreement, participated in any collusion, or otherwise taken any action which is in restraint of free competitive bidding in connection with any bid or contract, that the bidder has not been convicted of violating *N.C.G.S. § 133-24* within the last three years, and that the Bidder intends to do the work with its own bonafide employees or subcontractors and is not bidding for the benefit of another contractor.

In addition, execution of this bid in the proper manner also constitutes the Bidder's certification of status under penalty of perjury under the laws of the United States in accordance with the Debarment Certification attached, provided that the Debarment Certification also includes any required statements concerning exceptions that are applicable.

N.C.G.S. § 133-32 and Executive Order 24 prohibit the offer to, or acceptance by, any State Employee of any gift from anyone with a contract with the State, or from any person seeking to do business with the State. By execution of any response in this procurement, you attest, for your entire organization and its employees or agents, that you are not aware that any such gift has been offered, accepted, or promised by any employees of your organization.

SIGNATURE OF CONTRACTOR

Full Name of Firm

Address as Prequalified

Signature of Witness

Signature of Member / Manager / Authorized Agent
Select appropriate title

Print or type Signer's name

Print or type Signer's Name

**EXECUTION OF BID
NON-COLLUSION AFFIDAVIT, DEBARMENT CERTIFICATION AND GIFT BAN CERTIFICATION**

JOINT VENTURE (2) or (3)

The person executing the bid, on behalf of the Bidder, being duly sworn, solemnly swears (or affirms) that neither he, nor any official, agent or employee of the bidder has entered into any agreement, participated in any collusion, or otherwise taken any action which is in restraint of free competitive bidding in connection with any bid or contract, that the bidder has not been convicted of violating N.C.G.S. § 133-24 within the last three years, and that the Bidder intends to do the work with its own bonafide employees or subcontractors and is not bidding for the benefit of another contractor.

In addition, execution of this bid in the proper manner also constitutes the Bidder's certification of status under penalty of perjury under the laws of the United States in accordance with the Debarment Certification attached, provided that the Debarment Certification also includes any required statements concerning exceptions that are applicable.

N.C.G.S. § 133-32 and Executive Order 24 prohibit the offer to, or acceptance by, any State Employee of any gift from anyone with a contract with the State, or from any person seeking to do business with the State. By execution of any response in this procurement, you attest, for your entire organization and its employees or agents, that you are not aware that any such gift has been offered, accepted, or promised by any employees of your organization.

SIGNATURE OF CONTRACTORS

Instructions: **2 Joint Venturers** Fill in lines (1), (2) and (3) and execute. **3 Joint Venturers** Fill in lines (1), (2), (3) and (4) and execute. On Line (1), fill in the name of the Joint Venture Company. On Line (2), fill in the name of one of the joint venturers and execute below in the appropriate manner. On Line (3), print or type the name of the other joint venturer and execute below in the appropriate manner. On Line (4), fill in the name of the third joint venturer, if applicable and execute below in the appropriate manner.

(1) _____
Name of Joint Venture

(2) _____
Name of Contractor

Address as prequalified

Signature of Witness or Attest By Signature of Contractor

Print or type Signer's name Print or type Signer's name

If Corporation, affix Corporate Seal and

(3) _____
Name of Contractor

Address as prequalified

Signature of Witness or Attest By Signature of Contractor

Print or type Signer's name Print or type Signer's name

If Corporation, affix Corporate Seal and

(4) _____
Name of Contractor (for 3 Joint Venture only)

Address as prequalified

Signature of Witness or Attest By Signature of Contractor

Print or type Signer's name Print or type Signer's name

If Corporation, affix Corporate Seal

**EXECUTION OF BID
NON-COLLUSION AFFIDAVIT, DEBARMENT CERTIFICATION AND GIFT BAN CERTIFICATION**

INDIVIDUAL DOING BUSINESS UNDER A FIRM NAME

The person executing the bid, on behalf of the Bidder, being duly sworn, solemnly swears (or affirms) that neither he, nor any official, agent or employee of the bidder has entered into any agreement, participated in any collusion, or otherwise taken any action which is in restraint of free competitive bidding in connection with any bid or contract, that the bidder has not been convicted of violating *N.C.G.S. § 133-24* within the last three years, and that the Bidder intends to do the work with its own bonafide employees or subcontractors and is not bidding for the benefit of another contractor.

In addition, execution of this bid in the proper manner also constitutes the Bidder's certification of status under penalty of perjury under the laws of the United States in accordance with the Debarment Certification attached, provided that the Debarment Certification also includes any required statements concerning exceptions that are applicable.

N.C.G.S. § 133-32 and Executive Order 24 prohibit the offer to, or acceptance by, any State Employee of any gift from anyone with a contract with the State, or from any person seeking to do business with the State. By execution of any response in this procurement, you attest, for your entire organization and its employees or agents, that you are not aware that any such gift has been offered, accepted, or promised by any employees of your organization.

SIGNATURE OF CONTRACTOR

Name of Contractor

_____ Individual name

Trading and doing business as

_____ Full name of Firm

_____ Address as Prequalified

_____ Signature of Witness

_____ Signature of Contractor, Individually

_____ Print or type Signer's name

_____ Print or type Signer's name

**EXECUTION OF BID
NON-COLLUSION AFFIDAVIT, DEBARMENT CERTIFICATION AND GIFT BAN CERTIFICATION**

INDIVIDUAL DOING BUSINESS IN HIS OWN NAME

The person executing the bid, on behalf of the Bidder, being duly sworn, solemnly swears (or affirms) that neither he, nor any official, agent or employee of the bidder has entered into any agreement, participated in any collusion, or otherwise taken any action which is in restraint of free competitive bidding in connection with any bid or contract, that the bidder has not been convicted of violating *N.C.G.S. § 133-24* within the last three years, and that the Bidder intends to do the work with its own bonafide employees or subcontractors and is not bidding for the benefit of another contractor.

In addition, execution of this bid in the proper manner also constitutes the Bidder's certification of status under penalty of perjury under the laws of the United States in accordance with the Debarment Certification attached, provided that the Debarment Certification also includes any required statements concerning exceptions that are applicable.

N.C.G.S. § 133-32 and Executive Order 24 prohibit the offer to, or acceptance by, any State Employee of any gift from anyone with a contract with the State, or from any person seeking to do business with the State. By execution of any response in this procurement, you attest, for your entire organization and its employees or agents, that you are not aware that any such gift has been offered, accepted, or promised by any employees of your organization.

SIGNATURE OF CONTRACTOR

Name of Contractor _____
Print or type Individual name

Address as Prequalified

Signature of Contractor, Individually

Print or type Signer's Name

Signature of Witness

Print or type Signer's name

DEBARMENT CERTIFICATION

Conditions for certification:

1. The prequalified bidder shall provide immediate written notice to the Department if at any time the bidder learns that his certification was erroneous when he submitted his debarment certification or explanation that is file with the Department, or has become erroneous because of changed circumstances.
2. The terms *covered transaction, debarred, suspended, ineligible, lower tier covered transaction, participant, person, primary covered transaction, principal, proposal, and voluntarily excluded*, as used in this provision, have the meanings set out in the Definitions and Coverage sections of the rules implementing Executive Order 12549. A copy of the Federal Rules requiring this certification and detailing the definitions and coverages may be obtained from the Contract Officer of the Department.
3. The prequalified bidder agrees by submitting this form, that he will not knowingly enter into any lower tier covered transaction with a person who is debarred, suspended, declared ineligible, or voluntarily excluded from participation in NCDOT contracts, unless authorized by the Department.
4. For Federal Aid projects, the prequalified bidder further agrees that by submitting this form he will include the Federal-Aid Provision titled *Required Contract Provisions Federal-Aid Construction Contract (Form FHWA PR 1273)* provided by the Department, without subsequent modification, in all lower tier covered transactions.
5. The prequalified bidder may rely upon a certification of a participant in a lower tier covered transaction that he is not debarred, suspended, ineligible, or voluntarily excluded from the covered transaction, unless he knows that the certification is erroneous. The bidder may decide the method and frequency by which he will determine the eligibility of his subcontractors.
6. Nothing contained in the foregoing shall be construed to require establishment of a system of records in order to render in good faith the certification required by this provision. The knowledge and information of a participant is not required to exceed that which is normally possessed by a prudent person in the ordinary course of business dealings.
7. Except as authorized in paragraph 6 herein, the Department may terminate any contract if the bidder knowingly enters into a lower tier covered transaction with a person who is suspended, debarred, ineligible, or voluntarily excluded from participation in this transaction, in addition to other remedies available by the Federal Government.

DEBARMENT CERTIFICATION

The prequalified bidder certifies to the best of his knowledge and belief, that he and his principals:

- a. Are not presently debarred, suspended, proposed for debarment, declared ineligible, or voluntarily excluded from covered transactions by any Federal department or agency;
- b. Have not within a three-year period preceding this proposal been convicted of or had a civil judgment rendered against them for commission of fraud or a criminal offense in connection with obtaining, attempting to obtain, or performing a public (Federal, State or local) transaction or contract under a public transaction; violation of Federal or State antitrust statutes or commission of embezzlement, theft, forgery, bribery, falsification or destruction of records; making false statements; or receiving stolen property;
- c. Are not presently indicted for or otherwise criminally or civilly charged by a governmental entity (Federal, State or local) with commission of any of the offenses enumerated in paragraph b. of this certification; and
- d. Have not within a three-year period preceding this proposal had one or more public transactions (Federal, State or local) terminated for cause or default.
- e. Will submit a revised Debarment Certification immediately if his status changes and will show in his bid proposal an explanation for the change in status.

If the prequalified bidder cannot certify that he is not debarred, he shall provide an explanation with this submittal. An explanation will not necessarily result in denial of participation in a contract.

Failure to submit a non-collusion affidavit and debarment certification will result in the prequalified bidder's bid being considered non-responsive.

Check here if an explanation is attached to this certification.

Contract No.: **C 204196**

County: **Wake County**

ACCEPTED BY THE
DEPARTMENT OF TRANSPORTATION, NORTH CAROLINA TURNPIKE AUTHORITY

Contract Officer

NCTA Chief Engineer

Date

Date

Execution of Contract and Bonds
Approved as to Form:

Attorney General