

-- STATE OF NORTH CAROLINA--
DEPARTMENT OF TRANSPORTATION
RALEIGH, N.C.

INDUSTRY DRAFT REQUEST FOR PROPOSALS



DESIGN-BUILD PROJECT

TIP R-4902

October 25, 2011



VOID FOR BIDDING

DATE AND TIME OF TECHNICAL AND PRICE PROPOSAL SUBMISSION: **February 28, 2012 BY 4:00 PM**

DATE AND TIME OF PRICE PROPOSAL OPENING: **March 20, 2012 AT 2:00 PM**

CONTRACT ID: C 202831

WBS ELEMENT NO. 39929.3.1

FEDERAL-AID NO. IMNHF-485(8)

COUNTY: Mecklenburg

ROUTE NO. I-485

MILES: 6.6

LOCATION: I-485 from I-77 to US 521 (Johnston Road) south of Charlotte

TYPE OF WORK: DESIGN-BUILD AS SPECIFIED IN THE SCOPE OF WORK
CONTAINED IN THE REQUEST FOR PROPOSALS

NOTICE:

ALL PROPOSERS SHALL COMPLY WITH ALL APPLICABLE LAWS REGULATING THE PRACTICE OF GENERAL CONTRACTING AS CONTAINED IN CHAPTER 87 OF THE GENERAL STATUTES OF NORTH CAROLINA WHICH REQUIRES THE PROPOSER TO BE LICENSED BY THE N.C. LICENSING BOARD FOR CONTRACTORS WHEN BIDDING ON ANY NON-FEDERAL AID PROJECT WHERE THE BID IS \$30,000 OR MORE, EXCEPT FOR CERTAIN SPECIALTY WORK AS DETERMINED BY THE LICENSING BOARD. PROPOSERS SHALL ALSO COMPLY WITH ALL OTHER APPLICABLE LAWS REGULATING THE PRACTICES OF ELECTRICAL, PLUMBING, HEATING AND AIR CONDITIONING AND REFRIGERATION CONTRACTING AS CONTAINED IN CHAPTER 87 OF THE GENERAL STATUTES OF NORTH CAROLINA. NOT WITHSTANDING THESE LIMITATIONS ON BIDDING, THE PROPOSER WHO IS AWARDED ANY PROJECT SHALL COMPLY WITH CHAPTER 87 OF THE GENERAL STATUTES OF NORTH CAROLINA FOR LICENSING REQUIREMENTS WITHIN 60 CALENDAR DAYS OF BID OPENING, REGARDLESS OF FUNDING SOURCES.

5% BID BOND OR BID DEPOSIT REQUIRED

**PROPOSAL FORM FOR THE CONSTRUCTION OF CONTRACT NO. C202831
IN MECKLENBURG COUNTY, NORTH CAROLINA**

Date _____ 20 _____

**DEPARTMENT OF TRANSPORTATION,
RALEIGH, NORTH CAROLINA**

The Design-Build Team herein acknowledges that it has carefully examined the location of the proposed work to be known as Contract No. C202831; has carefully examined the Final Request for Proposals (RFP) and all addendums thereto, specifications, special provisions, the form of contract, and the forms of contract payment bond and contract performance bonds, which are acknowledged to be part of the Contract; and thoroughly understands the stipulations, requirements and provisions. The undersigned Design-Build Team agrees to be bound upon their execution of the Contract and including any subsequent award to them by the Board of Transportation in accordance with this Contract to provide the necessary contract payment bond and contract performance bond within fourteen calendar days after the written notice of award is received by them.

The undersigned Design-Build Team further agrees to provide all necessary materials, machinery, implements, appliances, tools, labor, and other means of construction, except as otherwise noted, to perform all the work and required labor to design, construct and complete all the work necessary for State Highway Contract No. C202831 in Mecklenburg County by no later than the dates(s) specified in the Final RFP or Technical Proposal, whichever is earlier, and in accordance with the requirements of the Engineer, the Final RFP and Addenda thereto, the *2012 Standard Specifications for Roads and Structures*, specifications prepared by the Department, the Technical Proposal prepared by the Design-Build Team, at the lump sum price(s) bid by the Design-Build Team in their Price Proposal.

The Design-Build Team shall provide signed and sealed documents prepared by the Design-Build Team, which specifications and plans show the details covering this project and adhere to the items noted above.

The Design-Build Team acknowledges that project documents furnished by the Department are preliminary and provided solely to assist the Design-Build Team in the development of the project design. Unless otherwise noted herein, the Department does not warrant or guarantee the sufficiency or accuracy of any information furnished by the Department.

The Department does not warrant or guarantee the sufficiency or accuracy of any investigations made, nor the interpretations made or opinions of the Department as to the type of materials and conditions to be encountered at the project site. The Design-Build Team is advised to make such independent investigations, as they deem necessary to satisfy their self as to conditions to be encountered on this project. The Design-Build Team shall have no claim for additional compensation or for an extension of contract time for any reason resulting from the actual conditions encountered at the site differing from those indicated in any of the information or documents furnished by the Department except as may be allowed under the provisions of the Standard Specifications.

Although the Department has furnished preliminary designs for this project, unless otherwise noted herein, the Design-Build Team shall assume full responsibility, including liability, for the

project design, including the use of portions of the Department design, modification of such design, or other designs as may be submitted by the Design-Build Team.

The Design-Build Team shall be fully and totally responsible for the accuracy and completeness of all work performed under this contract, and shall indemnify and hold the Department harmless for any additional costs and all claims against the Department or the State which may arise due to errors or omissions of the Department in furnishing the preliminary project designs and information, and of the Design-Build Team in performing the work.

The published volume entitled *North Carolina Department of Transportation, Raleigh, Standard Specifications for Roads and Structures, January 2012*, as well as, all design manuals, policy and procedures manuals, and AASHTO publications and guidelines referenced in the Request For Proposals, with all amendments and supplements thereto, are by reference, incorporated and made part of this contract; that, except as herein modified, all the design, construction and Construction Engineering Inspection included in this contract is to be done in accordance with the documents noted above and under the direction of the Engineer.

If the Design-Build Proposal is accepted and the award is made, the Technical Proposal submitted by the Design-Build Team is by reference, incorporated and made part of this contract. The contract is valid only when signed either by the Contract Officer or such other person as may be designated by the Secretary to sign for the Department of Transportation. The conditions and provisions herein cannot be changed except by written approval as allowed by the Request for Proposals.

Accompanying the Design-Build Proposal shall be a bid bond secured by a corporate surety, or certified check payable to the order of the Department of Transportation, for five percent of the total bid price, which deposit is to be forfeited as liquidated damages in case this bid is accepted and the Design-Build Team shall fail to provide the required payment and performance bonds with the Department of Transportation, under the condition of this proposal, within 14 calendar days after the written notice of award is received by them, as provided in the Standard Specifications; otherwise said deposit will be returned to the Design-Build Team.

**TO
BE
SEALED
IN
FINAL
RFP**

*Transportation Program
Management Director*

**TO
BE
SEALED
IN
FINAL
RFP**

State Contract Officer

TABLE OF CONTENTS

COVER SHEET

PROPOSAL SHEETS

PROJECT SPECIAL PROVISIONS	<small>(GREEN SHEETS)</small>	<i>PAGE NO.</i>
Contract Time and Liquidated Damages		1
Other Liquidated Damages		1
Payout Schedule.....		2
Mobilization.....		2
Substantial Completion.....		3
Submittal of Quantities, Fuel Base Index Price and Opt-Out Option.....		4
Individual Meetings with Proposers		5
Partnering.....		5
Execution of Bid, Non-Collusion Affidavit, Debarment Certification and Gift Ban Certification		6
Submission of Design-Build Proposal.....		7
Alternative Technical Concepts and Confidential Questions		7
Value Analysis.....		12
Schedule of Estimated Completion Progress.....		12
Revision to FHWA-1273 Concerning Personal Information on Payroll Submissions.....		12
Disadvantaged Business Enterprise		13
Certification for Federal-Aid Contracts.....		26
Contractor's License Requirements.....		26
U. S. Department of Transportation Hotline.....		27
Subsurface Information.....		27
Bid Documentation		27
Twelve Month Guarantee		30
Erosion & Sediment Control / Storm Water Certification.....		31
Procedure for Monitoring Borrow Pit Discharge.....		37
Clearing and Grubbing.....		38
Burning Restrictions		38
Cement and Lime Stabilization of Sub-Grade Soils		39
Price Adjustments for Asphalt Binder		43
Price Adjustments - Asphalt Concrete Plant Mix		43
Field Office		44
Foundations and Anchor Rod Assemblies for Metal Poles		46
Overhead Sign Supports		52
Overhead and Dynamic Message Sign Foundations		59
High Mount Foundations		61
Repair of Bridge Decks and Approach Pavement with Latex Modified Concrete.....		63
Employment.....		66

GENERAL (GREEN SHEETS)	67
SCOPES OF WORK (GREEN SHEETS)	
Roadway	83
Pavement Management.....	90
Structures	93
Geotechnical Engineering.....	96
Hydraulics	105
Traffic Management	107
Signing.....	125
ITS Conduit System	130
Pavement Markings	133
Signals	135
Railroad Coordination	136
Utilities Coordination	139
Geoenvironmental	145
Erosion and Sedimentation Control	146
Lighting.....	156
Environmental Permits	157
Public Information.....	162
STANDARD SPECIAL PROVISIONS (YELLOW SHEETS)	
Plant and Pest Quarantines	164
Gifts from Vendors and Contractors	164
Bridge Approach Fills	165
Preparation of Subgrade and Base	167
Asphalt Paver – Fixed and Mobile String Line.....	167
Asphalt Binder Content of Asphalt Plant Mixes	167
Asphalt Plant Mixtures	168
Final Surface Testing – Asphalt Pavements	168
Remove and Stockpile Existing Guardrail	169
Guardrail Anchor Units, Type M-350.....	169
Guardrail Anchor Units, Type 350.....	170
Impact Attenuator Units, Type 350.....	171
Preformed Scour Hole with Level Spreader Apron	173
Subsurface Drainage	174
Street Signs and Markers and Route Markers.....	174
Temporary Shoring.....	175
Coordination of Lighting Work	186
On-the-Job Training	186
Availability of Funds.....	189
NCDOT General Seed Specifications for Seed Quality.....	190
Award of Contract.....	193

Minority and Female Employment Requirements 194
Required Contract Provisions Federal-Aid Construction Contracts 197
General Decision NC100127 09/30/2011 NC127..... 207
Division One 210

PROPOSAL FORMS - ITEMIZED SHEET, ETC.

Itemized Proposal Sheet (WHITE SHEET)
Fuel Usage Factor Chart and Estimate of Quantities (WHITE SHEET)
Listing of DBE Subcontractors (YELLOW SHEETS)
Execution of Bid, Non-Collusion Affidavit, Debarment Certification and Gift Ban
Certification (YELLOW SHEETS)
Signature Sheet (YELLOW SHEET)

***** PROJECT SPECIAL PROVISIONS *****

CONTRACT TIME AND LIQUIDATED DAMAGES

07/12/07

DB1 G04A

The date of availability for this contract is [redacted], except that the Design-Build Team shall not begin ground disturbing activities, other than utility relocations in upland areas, until a meeting is held between the NCDOT, the regulatory agencies and the Design-Build Team; and the required permits have been acquired, as stipulated in the Environmental Permits Scope of Work contained elsewhere in this Request for Proposals (RFP). The Design-Build Team shall consider this factor in determining the proposed completion date for this project.

The completion date for this contract is defined as the date proposed in the Technical Proposal by the proposer who is awarded the project. The completion date thus proposed shall not be later than [redacted].

When observation periods are required by the special provisions, they are not a part of the work to be completed by the completion date and/or intermediate contract times. Should an observation period extend beyond the final completion date, the acceptable completion of the observation period shall be a part of the work covered by the performance and payment bonds.

The liquidated damages for this contract are [redacted] **Thousands Dollars (\$ [redacted].00)** per calendar day. As an exception to this amount, where the contract has been determined to be substantially complete as defined by the Special Provision entitled "Substantial Completion" found elsewhere in this RFP, the liquidated damages will be reduced to [redacted] **Thousand Dollars (\$ [redacted].00)** per calendar day.

Where the Design-Build Team who is awarded the contract has proposed a completion date for the contract as required above, but also has proposed an earlier date for substantial completion, then both of these proposed dates will become contract requirements.

Liquidated damages of [redacted] per calendar day will be applicable to the early date for substantial completion proposed by the bidder. Liquidated damages of [redacted] per calendar day will be applicable to the final completion date proposed by the bidder where the Design-Build Team has proposed an earlier date for substantial completion.

OTHER LIQUIDATED DAMAGES

(3/22/07) (Rev. 02/14/08)

DB1 G11

Refer to the Traffic Management Scope of Work for more information on the following time restrictions and liquidated damages:

Liquidated Damages for Intermediate Contract Time #1 for lane narrowing, lane closure, holiday and special event time restrictions for I-485, I-485 ramps / loops, US 521 and NC 51 are \$2,500 per 15-minute period or any portion thereof.

Liquidated Damages for Intermediate Contract Time #2 for lane narrowing, lane closure, holiday and special event time restrictions for East Westinghouse Boulevard are \$1,500 per 15-minute period or any portion thereof.

Liquidated Damages for Intermediate Contract Time #3 for road closure time restrictions for I-485, I-485 ramps / loops, US 521 and NC 51 are \$5,000.00 per 15-minute period or any portion thereof.

Liquidated Damages for Intermediate Contract Time #4 for road closure time restrictions for East Westinghouse Boulevard are \$2,500.00 per 15-minute period or any portion thereof.

Reference the Erosion and Sedimentation Control Scope of Work found elsewhere in this RFP for liquidated damages related to erosion and sediment control violations.

PAYOUT SCHEDULE

(11-16-09)

DB1 G13

No later than 12:00 o'clock noon on the sixth day after the opening of the Price Proposal, the responsive proposer with the lowest adjusted price shall submit a proposed Anticipated Monthly Payout Schedule to the office of the State Contract Officer. The information shall be submitted in a sealed package with the outer wrapping clearly marked "Anticipated Monthly Payout Schedule" along with the Design-Build Team name and the contract number. The Anticipated Monthly Payout Schedule will be used by the Department to establish the monthly funding levels for this project. The Anticipated Monthly Payout Schedule shall parallel, and agree with, the project schedule the Design-Build Team submits as a part of their Technical Proposal. The schedule shall include a monthly percentage breakdown (in terms of the total contract amount percentages) of the work anticipated to be completed. The schedule shall begin with the Date of Availability and end with the Actual Completion Date proposed by the Design-Build Team. If the Payout Schedule is not submitted as stated herein, the Technical and Price Proposals will be considered irregular by the Department, and the bid may be rejected.

Submit updates of the Anticipated Monthly Payout Schedule on March 15, June 15, September 15, and December 15 of each calendar year until project acceptance. Submit the all updates to the Resident Engineer with a copy to the State Construction Engineer at 1 South Wilmington St, 1543 Mail Service Center, Raleigh, NC 27699-1543.

MOBILIZATION

(10-31-05) (Rev 01-3-07)

DB1 G15B

Revise the 2012 *Standard Specifications for Roads and Structures* as follows:

Page 8-1, Subarticle 800-2, MEASUREMENT AND PAYMENT

Delete this subarticle in its entirety and replace with the following:

800-2 MEASUREMENT AND PAYMENT

5 percent of the “Total Amount of Bid for Entire Project” shall be considered the lump sum amount for Mobilization. Partial payments for Mobilization will be made beginning with the first partial pay estimate paid on the contract. Payment will be made at the rate of 50 percent of the lump sum amount calculated for Mobilization. The remaining 50 percent will be paid with the partial pay estimate following approval of all permits required in the Environmental Permits Scope of Work for this project.

SUBSTANTIAL COMPLETION

(3-22-07)

DB1 G16

When the special provisions provide for a reduction in the rate of liquidated damages for the contract time or an intermediate contract time after the work is substantially complete, the work will be considered substantially complete when the following requirements are satisfied:

1. Through traffic has been placed along the project or along the work required by an intermediate contract time and the work is complete to the extent specified below, and all lanes and shoulders are open such that traffic can move unimpeded at the posted speed. Intersecting roads and service roads are complete to the extent that they provide the safe and convenient use of the facility by the public.
2. The final layers of pavement for all lanes and shoulders along the project or along the work required by an intermediate contract time are complete.
3. All signs are complete and accepted except for the signs on intersecting roadways.
4. All guardrails, drainage devices, ditches, excavation and embankment are complete.
5. Remaining work along the project consists of permanent pavement markings, permanent pavement markers or incidental construction that is away from the paved portion of the roadway.

Upon apparent substantial completion of the entire project or the work required by an intermediate contract time, the Engineer will make an inspection of the work. If the inspection discloses the entire project or the work required by an intermediate contract time is substantially complete; the Engineer will notify the Design-Build Team in writing that the work is substantially complete. If the inspection discloses the entire project or the work required by an intermediate contract time is not substantially complete, the Engineer will notify the Design-Build Team in writing of the work that is not substantially complete. The entire project or the work required by an intermediate contract time will not be considered substantially complete until all of the recommendations made at the time of the inspection have been satisfactorily completed.

SUBMITTAL OF QUANTITIES, FUEL BASE INDEX PRICE AND OPT-OUT OPTION

(06-08-11)

DB1 G43

(A) Submittal of Quantities

Submit quantities on the *Fuel Usage Factor Chart and Estimate of Quantities* sheet, located in the back of this RFP, following the Itemized Proposal Sheet.

The Design-Build Team shall prepare an Estimate of Quantities that they anticipate incorporating into the completed project and upon which the Price Proposal was based. The quantity breakdown shall include all items of work that appear in the *Fuel Usage Factor Chart and Estimate of Quantities* sheet. Only those items of work which are specifically noted in the Fuel Usage Factor Chart will be subject to fuel price adjustments. The quantity estimate submitted in the Price Proposal shall be the final total quantity limit for which fuel price adjustments will be made for each item, regardless of supplemental agreements. The Department will review the Estimate of Quantities to ensure its reasonableness to the proposed design. Agreement of quantities will be a prerequisite prior to execution of the contract.

Submittal The submittal shall be signed and dated by an officer of the Design-Build Team. The information shall be copied and submitted in a separate sealed package with the outer wrapping clearly marked "Fuel Price Adjustment" and shall be delivered at the same time and location as the Technical and Price Proposal. The original shall be submitted in the Price Proposal.

Trade Secret Information submitted on the *Fuel Usage Factor Chart and Estimate of Quantities* sheet will be considered "Trade Secret" in accordance with the requirements of G.S. 66-152(3) until such time as the Price Proposal is opened.

(B) Base Index Price

The Design-Build Team's Estimate of Quantities will be used on the various partial payment estimates to determine fuel price adjustments. The Design-Build Team shall submit a payment request for quantities of work completed based on the work completed for that estimate period. The quantities requested for partial payment shall be reflective of the work actually accomplished for the specified period. The Design-Build Team shall certify that the quantities are reasonable for the specified period. The base index price for DIESEL #2 FUEL is \$ per gallon.

(C) Opt Out of Fuel Price Adjustment

If the Design-Build Team elects not to pursue reimbursement for Fuel Price Adjustments, a quantity of zero shall be entered for all quantities in the *Fuel Usage Factor Chart and Estimate of Quantities* and the declination box shall be checked. Failure to complete this form will mean that the Design-Build Team is declining the Fuel Price Adjustments for this project.

(D) Change Option

The proposer will not be permitted to change the option after the Price Proposal and the copy of the *Fuel Usage Factor Chart and Estimate of Quantities* sheet are submitted.

(E) Failure to Submit

Failure to submit the completed *Fuel Usage Factor Chart and Estimate of Quantities* sheet separately and in the Price Proposal will result in the Technical and Price Proposal being considered irregular by the Department and the Technical and Price Proposal may be rejected.

INDIVIDUAL MEETINGS WITH PROPOSERS

(9-1-11)

DB1 G048

The Department will provide at least two Question and Answer Sessions to meet with each proposer individually to specifically address questions regarding the draft Requests for Proposals.

The Department will attempt to arrange for a meeting between each individual proposer and the affected utility owners.

The Department will afford each proposer one additional meeting with the Department to discuss project specifics and address the proposers' concerns and questions. This meeting may occur at any time after the first Question and Answer Session with the proposers and before two weeks prior to the date of Technical and Price Proposals submission. The proposer shall request this meeting in writing to the State Contract Officer, providing the Department a minimum of one week advance notice of the requested date. The proposer shall also state in the request those disciplines within the Department that are requested to be in attendance. The Department makes no assurance that the request may be honored on that specific date or that all disciplines requested can be in attendance.

Additional individual meetings may be permitted in accordance with the *Alternative Technical Concepts and Confidential Questions* Project Special Provision found elsewhere in this RFP.

PARTNERING

07/29/09

DB1 G49

As a part of its quality management program, the North Carolina Department of Transportation intends to encourage the formation of a cohesive relationship with the Design-Build Team and its principal subcontractors and suppliers. This relationship will be structured to draw on the strengths of each organization to identify and achieve reciprocal goals. The objectives are safe, effective, and efficient contract performance; and completion within budget, on schedule, and in accordance with the plans and specifications.

This relationship will be bilateral in makeup and participation will be totally voluntary. The cost associated with effectuating this relationship will be agreed to by both parties and shall be shared

equally. Compensation for the Department's share of the partnering costs will be by Supplemental Agreement.

To implement this initiative prior to starting work in accordance with the requirements of Section 108 of the 2012 *Standard Specifications for Roads and Structures* and the Standard Special Provision for Division One (found elsewhere in this RFP), and prior to the preconstruction conference, the Design-Build Team's management personnel and Division Construction Engineer will initiate a partnering development seminar/team building workshop. Project personnel working with the assistance of the Construction Unit will make arrangements to determine attendees at the workshop, agenda of the workshop, duration, and location. Persons required to be in attendance will be the NCDOT Resident Engineer, the NCDOT Division Construction Engineer, and key project personnel; the Design-Build Team's senior management personnel, the Design-Build Team's on-site project manager, and key project supervisory personnel for both the Design-Build Team and principal subcontractors and suppliers. The project design engineers, FHWA, and key local government personnel will also be invited to attend as necessary.

Follow-up workshops may be held periodically throughout the duration of the contract as agreed by the Design-Build Team and the North Carolina Department of Transportation. In the event that additional workshops are held, compensation for the Department's share of the follow-up partnering workshops will be by Supplemental Agreement.

The establishment of the partnering charter on a project will not change the legal relationship to the contract nor relieve either party from any of the terms of the contract.

**EXECUTION OF BID, NON-COLLUSION AFFIDAVIT, DEBARMENT
CERTIFICATION AND GIFT BAN CERTIFICATION**

(6-08-11)

DB1 G52

The Proposer's attention is directed to the various sheets in the Request for Proposals which are to be signed by the Proposer. A list of these sheets is shown below. The signature sheets are located behind the Itemized Proposal Sheet in this Request for Proposal. The NCDOT bid bond form is available on-line at:

http://www.ncdot.org/doh/preconstruct/altern/design_build/DesignbuildBidBond.pdf

or by contacting the Records and Documents office at 919-770-6900.

1. Applicable Signature Sheets: 1, 2, 3, 4, 5, or 6 (Bid)
2. Bid Bond dated the day of Technical and Price Proposal submission

The Proposer shall certify to the best of his knowledge all subcontractors, material suppliers and vendors utilized herein current status concerning suspension, debarment, voluntary exclusion, or determination of ineligibility by any federal agency, in accordance with the "Debarment Certification" located behind the *Execution of Bid Non-Collusion Affidavit, Debarment Certification and Gift Ban Certification* signature sheets in this RFP. Execution of the bid

signature sheets in conjunction with any applicable statements concerning exceptions, when such statements have been made on the "Debarment Certification", constitutes the Proposer's certification of "status" under penalty of perjury under the laws of the United States.

SUBMISSION OF DESIGN-BUILD PROPOSAL

(9-1-11)

DB1 G55A

The Proposer's attention is directed that each Proposer's Design-Build Proposal shall comply with the following requirements in order for that Design-Build Proposal to be responsive and considered for award.

1. The Proposer shall be prequalified with the Department prior to submitting a Design-Build Proposal.
2. The Proposer shall deliver the Design-Build Proposal to the place indicated, and prior to the time indicated in this Request for Proposals.
3. The Design-Build Proposal documents shall be signed by an authorized employee of the Proposer.
4. The Design-Build Proposal shall be accompanied by Bid surety in the form of a Bid Bond or Bid Deposit, dated the day of Technical and Price Proposal submission.
5. If Disadvantaged Business Enterprises (DBE) goals are established for this contract, the Proposer shall complete the form Listing of DBE Subcontractors contained elsewhere in this RFP in accordance with the Project Special Provision entitled Disadvantaged Business Enterprises.
6. The Design-Build Proposal shall address all the requirements as specified in this Request for Proposals.

In addition to the above requirements, failure to comply with any of the requirements of Article 102-8 of the Standard Special Provisions, Division One (found elsewhere in this RFP), Article 102-9 of the 2012 *Standard Specifications for Roads and Structures*, or Article 102-10 of the 2012 *Standard Specifications for Roads and Structures* and as amended in the Standard Special Provisions, Division One (found elsewhere in this RFP) may result in a Design-Build Proposal being rejected.

ALTERNATIVE TECHNICAL CONCEPTS AND CONFIDENTIAL QUESTIONS

(06-08-11)

DB1 G56A

To accommodate innovation that may or may not be specifically allowed by the RFP, or other documents incorporated into the contract by reference, the Design-Build Team has the option of submitting Confidential Questions and Alternative Technical Concepts.

Definitions

A Confidential Question is defined as a private query to the Department containing information whose disclosure could alert others to certain details of doing business in a particular manner.

An Alternative Technical Concept is a private query to the Department that requests a variance to the requirements of the RFP, or other documents incorporated into the contract by reference, that is equal or better in quality or effect as determined by the Department in its sole discretion and that have been used elsewhere under comparable circumstances.

Confidential Questions

The Design-Build Team will be permitted to ask Confidential Questions of the Department, and neither the question nor the answer will be shared with other Design-Build Teams. The Department, in its sole discretion, will determine if a question is considered confidential.

Confidential Questions arising prior to issuance of the Final RFP will be allowed during the industry review of the draft RFP with the individual Design-Build Teams. The Department will answer the Confidential Question verbally at the industry review meeting, if possible, and/or through subtle changes in the Final RFP, which will clarify the scope by either allowing or disallowing the request. To the greatest extent possible, the revision will be made in such a manner as to not disclose the Confidential Question.

After the issuance of the Final RFP, Confidential Questions may be asked by requesting a meeting with the State Contract Officer. The request shall be in writing and provide sufficient detail to evaluate the magnitude of the request. Questions shall be of such magnitude as to warrant a special meeting. Minor questions will not be acknowledged or answered. After evaluation, the State Contract Officer will respond to the question in writing to the Design-Build Team and/or through subtle changes in the Final RFP as reflected in an addendum, which will clarify the scope by either allowing or disallowing the request. To the greatest extent possible, the revision will be made in such a manner as to not disclose the Confidential Question.

If the Design-Build Team includes work based on the Confidential Questions and answers, the work shall be discussed in the Technical Proposal.

Alternative Technical Concepts

The Design-Build Team may include an ATC in the Technical and Price Proposal only if the ATC has been received by the Department by no later than three weeks prior to the deadline for submitting Technical and Price Proposals and it has been approved by the Department (including conditionally approved ATCs, if all conditions are met).

The submittal deadline above applies only to initial ATC submittals. Resubmittal of an ATC that (1) has been revised in response to the Department's requests for further information concerning a prior submittal or (2) is a Formal ATC for a Preliminary ATC that received a favorable

response from the Department shall be received by the Department no later than one week prior to the deadline for submitting Technical and Price Proposals.

Should the Department revise the RFP after a Formal ATC has been approved, the Design-Build Team shall be solely responsible for reviewing the RFP and determining if the ATC deviates from the revised requirements. If necessary, the Design-Build Team must submit a request for approval of all additional required variance(s) within five business days of the revised RFP distribution.

An ATC shall in no way take advantage of an error or omission in the RFP, or other documents incorporated into the contract by reference. If, at the sole discretion of the Department, an ATC is deemed to take an advantage of an error or omission in the RFP, or other documents incorporated into the contract by reference, the RFP will be revised without regard to confidentiality. If at any time, the Department receives a question on the project similar to a concept submitted in the form of a Preliminary ATC or Formal ATC, the Department reserves the right to revise the RFP without further regard for confidentiality.

By approving an ATC, the Department acknowledges that the ATC may be included in the design and RFC plans; however, approval of any ATC in no way relieves the Design-Build Team of its obligation to satisfy (1) other contract requirements not specifically identified in the ATC submittal; (2) any obligation that may arise under applicable laws and regulations; and (3) any obligation mandated by the regulatory agencies as a permit condition.

ATC Submittals

Each ATC submittal shall include three individually bound hard copies and an electronic pdf file of the entire submittal and shall be submitted to the State Contract Officer at the address provided elsewhere in this RFP.

Formal ATCs

Each Formal ATC submittal shall include the following information:

- 1) Description. A detailed description and schematic drawings of the configuration of the ATC or other appropriate descriptive information (including, if appropriate, product details [i.e., specifications, construction tolerances, special provisions] and a traffic operational analysis, if appropriate);
- 2) Usage. Where and how the ATC would be used on the project;
- 3) Deviations. References to all requirements of the RFP, or other documents incorporated into the contract by reference, that are inconsistent with the proposed ATC, an explanation of the nature of the deviations from said requirements, and a request for approval of such variance(s);
- 4) Analysis. An analysis justifying use of the ATC and why the variance to the requirements of the RFP, or other documents incorporated into the contract by reference, should be allowed;

- 5) Impacts. Discussion of potential impacts on vehicular traffic, environmental impacts identified, community impact, safety and life-cycle project impacts, and infrastructure costs (including impacts on the cost of repair and maintenance);
- 6) History. A detailed description of other projects where the ATC has been used, the success of such usage, and names and telephone numbers of project owners that can confirm such statements;
- 7) Risks. A description of added risks to the Department and other entities associated with implementing the ATC; and
- 8) Costs. An estimate of the ATC implementation costs to the Department, the Design-Build Team, and other entities (right-of-way, utilities, mitigation, long term maintenance, etc.).

The Formal ATC, if approved, shall be included in the Price Proposal if the Design-Build Team elects to include it in their Technical Proposal.

Review of ATCs

A panel will be selected to review each ATC, which may or may not include members of the Technical Review Committee. The Design-Build Team shall make no direct contact with any member of the review panel, except as may be permitted by the State Contract Officer. Unapproved contact with any member of the review panel will result in a disqualification of that ATC.

The Department may request additional information regarding a proposed ATC at any time. To the greatest extent possible, the Department will return responses to, or request additional information from, the Design-Build Team within 15 business days of the original submittal of a Formal ATC. If additional information is requested, the Department will provide a response within 5 business days of receipt of all requested information.

The Department may conduct confidential one-on-one meeting(s) to discuss the Design-Build Team's ATC. Under no circumstances will the Department be responsible or liable to the Design-Build Team or any other party as a result of disclosing any ATC materials, whether the disclosure is deemed required by law, by an order of court, or occurs through inadvertence, mistake or negligence on the part of the Department or their respective officers, employees, contractors, or consultants.

In the event that the Department receives ATCs from more than one Design-Build Team that are deemed by the Department to be similar in nature, the Department reserves the right to modify the RFP without further regard for confidentiality.

The Department Response to Formal ATCs

The Department will review each Formal ATC and will respond to the Design-Build Team with one of the following determinations:

- 1) The ATC is approved;
- 2) The ATC is not approved;

- 3) The ATC is not approved in its present form, but may be approved upon satisfaction, in the Department's sole discretion, of certain identified conditions that shall be met or certain clarifications or modifications that shall be made (conditionally approved);
- 4) The submittal does not qualify as an ATC but may be included in the Proposal without an ATC (i.e., the concept complies with the baseline requirements of the RFP);
- 5) The submittal does not qualify as an ATC and may not be included in the Proposal;
- 6) The ATC is deemed to take advantage of an error or omission in the RFP, or other documents incorporated into the contract by reference, in which case the ATC will not be considered, and the RFP will be revised to correct the error or omission.
- 7) A question has been received outside of the ATC process on the same topic and the RFP will be revised to address that question; or
- 8) More than one ATC has been received on the same topic and the Department has elected to exercise its right to revise the RFP. This response could also follow and supersede one of the other previously supplied responses above.

Formal ATC Inclusion in Technical Proposal

The Design-Build Team may incorporate one or more approved Formal ATCs as part of its Technical and Price Proposals. If the Department responded to an Formal ATC by stating that it would be approved if certain conditions were met, those conditions shall be stipulated and met in the Technical Proposal.

In addition to outlining each implemented Formal ATC, and providing assurances to meet all attached conditions, The Design-Build Team shall also include a copy of the Formal ATC approval letter from the State Contract Officer in each of the twelve Technical Proposals submitted. This letter will be included in the distribution of the Technical Proposals to the Technical Review Committee.

Approval of an Formal ATC in no way implies that the Formal ATC will receive a favorable review from the Technical Review Committee. The Technical Proposals will be evaluated in regards to the evaluation criteria found in this RFP, regardless of whether or not Formal ATCs are included.

The Price Proposal shall reflect all incorporated Formal ATCs. Except for incorporating approved Formal ATCs, the Technical Proposal may not otherwise contain exceptions to, or deviations from, the requirements of the RFP, or other documents incorporated into the contract by reference.

Preliminary ATCs

At the Design-Build Team's option, a Preliminary ATC submittal may be made that presents a concept and a brief narrative of the benefits of said concept. The purpose of allowing such a Preliminary ATC is to limit the Design-Build Team's expense in the pursuit of a Formal ATC that may be quickly denied by the Department.

To the greatest extent possible, the Department will review Preliminary ATCs within 10 business days of submittal and provide written comments and one of the responses noted below. The Department’s response to a Preliminary ATC submittal will be either (1) that the Preliminary ATC is denied; (2) that the Preliminary ATC would be considered as a Formal ATC if the Team so elects to pursue a Formal ATC submission; (3) that an ATC is not required; (4) a question has been received outside of the ATC process on the same topic and the RFP will be revised to address that question; or (5) that the ATC takes advantage of an error or omission in the RFP or other documents incorporated into the contract by reference, in which case the ATC will not be considered and the RFP will be revised to correct the error or omission. The Department in no way warrants that a favorable response to a Preliminary ATC submittal will translate into a favorable response to a Formal ATC submittal. Likewise, a favorable response to a Preliminary ATC submittal is not sufficient to include the ATC in a Technical Proposal.

VALUE ANALYSIS

(9-1-11)

DB1 G57

Value Engineering Proposals, as specified in Article 104-12 of the 2012 *Standard Specifications for Roads and Structures* will be accepted. Only proposals, which alter the requirements of the RFP issued by the Department, will be considered as Value Engineering Proposals.

SCHEDULE OF ESTIMATED COMPLETION PROGRESS

(9-1-11)

DB1 G58

The Design-Build Team's attention is directed to the Standard Special Provision entitled "Availability of Funds - Termination of Contracts" included elsewhere in this RFP. The Department of Transportation's schedule of estimated completion progress for this project as required by that Standard Special Provision is as follows:

<u>Fiscal Year</u>	<u>Progress (Dollar Value)</u>
2012 (07/01/11 – 06/30/12)	____ % of Total Amount Bid
2013 (07/01/12 – 06/30/13)	____ % of Total Amount Bid
2014 (07/01/13 – 06/30/14)	____ % of Total Amount Bid
2015 (07/01/14 – 06/30/15)	____ % of Total Amount Bid
2016 (07/01/15 – 06/30/16)	____ % of Total Amount Bid

The Design-Build Team shall also furnish its own progress schedule in accordance with Article 108-2 of the 2012 *Standard Specifications for Roads and Structures*. Any acceleration of the progress as shown by the Design-Build Team's progress schedule over the progress as shown above shall be subject to the approval of the Engineer.

REVISION TO FHWA-1273 CONCERNING PERSONAL INFORMATION ON PAYROLL SUBMISSIONS:

(1-20-09)

DB1G59

Revise the *Standard Special Provision FHWA-1273 Required Contract Provisions Federal-Aid Construction Contracts* as follows:

Section V, Paragraph 2b is replaced with the following:

The payroll records shall contain the name, and the last four digits of the social security number of each such employee, his or her correct classification; hourly rates of wages paid (including rates of contributions or costs anticipated for bona fide fringe benefits or cash equivalent thereof the types described in Section 1(b)(2)(B) of the Davis Bacon Act); daily and weekly number of hours worked; deductions made; and actual wages paid.

DISADVANTAGED BUSINESS ENTERPRISE

(9-1-11)

DB1 G061

Description

The purpose of this Special Provision is to carry out the U.S. Department of Transportation's policy of ensuring nondiscrimination in the award and administration of contracts financed in whole or in part with Federal funds. This provision is guided by 49 CFR Part 26.

Definitions

Additional DBE Subcontractors - Any DBE submitted at the time of bid that will not be used to meet the DBE goal. No submittal of a Letter of Intent is required.

Committed DBE Subcontractor - Any DBE submitted at the time of bid that is being used to meet the DBE goal by submission of a Letter of Intent. Or any DBE used as a replacement for a previously committed DBE firm.

Contract Goal Requirement - The approved DBE participation at time of award, but not greater than the advertised contract goal.

DBE Goal - A portion of the total contract, expressed as a percentage, that is to be performed by committed DBE subcontractor(s).

Disadvantaged Business Enterprise (DBE) - A firm certified as a Disadvantaged Business Enterprise through the North Carolina Unified Certification Program.

Goal Confirmation Letter - Written documentation from the Department to the Proposer confirming the Design-Build Team's approved, committed DBE participation along with a listing of the committed DBE firms.

Manufacturer - A firm that operates or maintains a factory or establishment that produces on the premises, the materials or supplies obtained by the Design-Build Team.

Regular Dealer - A firm that owns, operates, or maintains a store, warehouse, or other establishment in which the materials or supplies required for the performance of the contract are bought, kept in stock, and regularly sold to the public in the usual course of business. A regular dealer engages in, as its principal business and in its own name, the purchase and sale or lease of the products in question. A regular dealer in such bulk items as steel, cement, gravel, stone, and

petroleum products need not keep such products in stock, if it owns and operates distribution equipment for the products. Brokers and packagers are not regarded as manufacturers or regular dealers within the meaning of this section.

North Carolina Unified Certification Program (NCUCP) - A program that provides comprehensive services and information to applicants for DBE certification, such that an applicant is required to apply only once for a DBE certification that will be honored by all recipients of USDOT funds in the state and not limited to the Department of Transportation only. The Certification Program is in accordance with 49 CFR Part 26.

United States Department of Transportation (USDOT) - Federal agency responsible for issuing regulations (49 CFR Part 26) and official guidance for the DBE program.

Forms and Websites Referenced in this Provision

DBE Payment Tracking System - On-line system in which the Design-Build Team enters the payments made to DBE subcontractors who have performed work on the project.
<https://apps.dot.state.nc.us/Vendor/PaymentTracking/>

RF-1 DBE Replacement Request Form - Form for replacing a committed DBE.
https://apps.dot.state.nc.us/_includes/download/external.html?pdf=http%3A//www.ncdot.gov/doh/forms/files/RF-1.pdf

SAF Subcontract Approval Form - Form required for approval to sublet the contract.
http://www.ncdot.org/doh/operations/dp_chief_eng/constructionunit/saf.xls

JC-1 Joint Check Notification Form - Form and procedures for joint check notification. The form acts as a written joint check agreement among the parties providing full and prompt disclosure of the expected use of joint checks.
https://apps.dot.state.nc.us/_includes/download/external.html?pdf=http%3A//www.ncdot.gov/doh/forms/files/JC-1.pdf

Letter of Intent - Form signed by the Contractor and the DBE subcontractor, manufacturer or regular dealer that affirms that a portion of said contract is going to be performed by the signed DBE for the amount listed at the time of bid.
<http://www.ncdot.org/doh/preconstruct/ps/contracts/letterofintent.pdf>

Listing of DBE Subcontractors Form - Form for entering DBE subcontractors on a project that will meet this DBE goal contained elsewhere in this RFP.

Subcontractor Quote Comparison Sheet - Spreadsheet for showing all subcontractor quotes in the work areas where DBEs quoted on the project. This sheet is submitted with good faith effort packages.
http://www.ncdot.gov/business/ocs/goodfaith/excel/Ex_Subcontractor_Quote_Comparison.xls

DBE Goal

The following DBE goal for participation by Disadvantaged Business Enterprises is established for this contract:

Disadvantaged Business Enterprises **11%**

- (A) *If the DBE goal is more than zero*, the Design-Build Team shall exercise all necessary and reasonable steps to ensure that DBEs participate in at least the percent of the contract as set forth above as the DBE goal.
- (B) *If the DBE goal is zero*, the Design-Build Team shall make an effort to recruit and use DBEs during the performance of the contract. Any DBE participation obtained shall be reported to the Department.

This goal is to be met through utilization of highway construction contractors and/or right-of-way acquisition firms. Utilization of DBE firms performing design, other preconstruction services, or Construction Engineering and Inspection are not included in this goal.

Directory of Transportation Firms (Directory)

Real-time information is available about firms doing business with the Department and firms that are certified through NCUCP in the Directory of Transportation Firms. Only firms identified in the Directory as DBE certified shall be used to meet the DBE goal. The Directory can be found at the following link. <https://partner.ncdot.gov/VendorDirectory/default.html>

The listing of an individual firm in the directory shall not be construed as an endorsement of the firm's capability to perform certain work.

Listing of DBE Subcontractors

At the time of bid, Proposers shall submit all DBE participation that they anticipate to use during the life of the contract. Only those identified to meet the DBE goal will be considered committed, even though the listing shall include both committed DBE subcontractors and additional DBE subcontractors. Additional DBE subcontractor participation submitted at the time of bid will be used toward the Department's overall race-neutral goal. Only those firms with current DBE certification at the time of Price Proposal opening will be acceptable for listing in the Proposer's submittal of DBE participation. The Design-Build Team shall indicate the following required information:

Blank forms will not be deemed to represent zero participation. Price Proposals submitted that do not have DBE participation indicated on the appropriate form will not be read publicly during the opening of the Price Proposals. The Department will not consider these Price Proposals for award and the proposal will be rejected.

- (1) *If the DBE goal is more than zero,*
 - (a) Proposers, at the time the Price Proposal is submitted, shall submit a listing of DBE participation, including the names and addresses on *Listing of DBE Subcontractors* contained elsewhere in the contract documents in order for the Price Proposal to be considered responsive. Proposers shall indicate the total dollar value of the DBE participation for the contract.
 - (b) If Proposers have no DBE participation, they shall indicate this on the *Listing of DBE Subcontractors* by entering the word “None” or the number “0.” This form shall be completed in its entirety.
 - (c) The Proposer shall be responsible for ensuring that the DBE is certified at the time of bid by checking the Directory of Transportation Firms. If the firm is not certified at the time of the opening of the Price Proposals, that DBE’s participation will not count towards achieving the DBE goal.
- (2) *If the DBE goal is zero,* Proposers, at the time the Price Proposal is submitted, shall enter the word “None”; or the number “0”; or if there is participation, add the value on the *Listing of DBE Subcontractors* contained elsewhere in the contract documents.

DBE Prime Contractor

When a certified DBE firm proposes on a contract that contains a DBE goal, the DBE firm is responsible for meeting the goal or making good faith efforts to meet the goal, just like any other proposer. In most cases, a DBE proposer on a contract will meet the DBE goal by virtue of the work it performs on the contract with its own forces. However, all the work that is performed by the DBE proposer and any other DBE subcontractors will count toward the DBE goal. The DBE proposer shall list itself along with any DBE subcontractors, if any, in order to receive credit toward the DBE goal.

For example, if the DBE goal is 45% and the DBE proposer will only perform 40% of the contract work, the prime will list itself at 40%, and the additional 5% shall be obtained through additional DBE participation with DBE subcontractors or documented through a good faith effort.

DBE prime contractors shall also follow Sections A and B listed under *Listing of DBE Subcontractor* just as a non-DBE proposer would.

Written Documentation – Letter of Intent

The Proposer shall submit written documentation for each DBE that will be used to meet the DBE goal of the contract, indicating the Proposer’s commitment to use the DBE in the contract. This documentation shall be submitted on the Department’s form titled *Letter of Intent*.

The documentation shall be received in the office of the State Contractor Utilization Engineer or at DBE@ncdot.gov no later than 12:00 noon of the sixth calendar day following opening of Price

Proposals, unless the sixth day falls on an official state holiday. In that situation, it is due in the office of the State Contractor Utilization Engineer no later than 12:00 noon on the next official state business day.

If the Proposer fails to submit the Letter of Intent from each committed DBE to be used toward the DBE goal, or if the form is incomplete (i.e. both signatures are not present), the DBE participation will not count toward meeting the DBE goal. If the lack of this participation drops the commitment below the DBE goal, the Design-Build Team shall submit evidence of good faith efforts, completed in its entirety, to the State Contractor Utilization Engineer or DBE@ncdot.gov no later than 12:00 noon on the eighth calendar day following opening of the Price Proposals, unless the eighth day falls on an official state holiday. In that situation, it is due in the office of the State Contractor Utilization Engineer no later than 12:00 noon on the next official state business day.

Submission of Good Faith Effort

If the Proposer fails to meet or exceed the DBE goal the Proposer with the apparent adjusted low price shall submit to the Department documentation of adequate good faith efforts made to reach the DBE goal.

A hard copy and an electronic copy of this information shall be received in the office of the State Contractor Utilization Engineer or at DBE@ncdot.gov no later than 12:00 noon of the sixth calendar day following opening of the Price Proposals unless the sixth day falls on an official state holiday. In that situation, it is due in the office of the State Contractor Utilization Engineer the next official state business day. If the Design-Build Team cannot send the information electronically, then one complete set and 9 copies of this information shall be received under the same time constraints above.

Note: Where the information submitted includes repetitious solicitation letters, it will be acceptable to submit a representative letter along with a distribution list of the firms that were solicited. Documentation of DBE quotations shall be a part of the good faith effort submittal. This documentation may include written subcontractor quotations, telephone log notations of verbal quotations, or other types of quotation documentation.

Consideration of Good Faith Effort for Projects with DBE Goals More Than Zero

Adequate good faith efforts mean that the Proposer took all necessary and reasonable steps to achieve the goal which, by their scope, intensity, and appropriateness, could reasonably be expected to obtain sufficient DBE participation. Adequate good faith efforts also mean that the Proposer actively and aggressively sought DBE participation. Mere *pro forma* efforts are not considered good faith efforts.

The Department will consider the quality, quantity, and intensity of the different kinds of efforts a Proposer has made. Listed below are examples of the types of actions a proposer will take in making a good faith effort to meet the goal and are not intended to be exclusive or exhaustive, nor is it intended to be a mandatory checklist.

- (A) Soliciting through all reasonable and available means (e.g. attendance at pre-bid meetings, advertising and/or written notices through the use of the NCDOT Directory of Transportation Firms) the interest of all certified DBEs who have the capability to perform the work of the contract. The Proposer must solicit this interest within at least 10 days prior to the opening of the Price Proposals to allow the DBEs to respond to the solicitation. Solicitation shall provide the opportunity to DBEs within the Division and surrounding Divisions where the project is located. The Proposer must determine with certainty if the DBEs are interested by taking appropriate steps to follow up initial solicitations.
- (B) Selecting portions of the work to be performed by DBEs in order to increase the likelihood that the DBE goals will be achieved. This includes, where appropriate, breaking out contract work items into economically feasible units to facilitate DBE participation, even when the prime contractor might otherwise prefer to perform these work items with its own forces.
- (C) Providing interested DBEs with adequate information about the plans, specifications, and requirements of the contract in a timely manner to assist them in responding to a solicitation.
- (D)
 - (1) Negotiating in good faith with interested DBEs. It is the Proposer's responsibility to make a portion of the work available to DBE subcontractors and suppliers and to select those portions of the work or material needs consistent with the available DBE subcontractors and suppliers, so as to facilitate DBE participation. Evidence of such negotiation includes the names, addresses, and telephone numbers of DBEs that were considered; a description of the information provided regarding the plans and specifications for the work selected for subcontracting; and evidence as to why additional agreements could not be reached for DBEs to perform the work.
 - (2) A proposer using good business judgment would consider a number of factors in negotiating with subcontractors, including DBE subcontractors, and would take a firm's price and capabilities as well as contract goals into consideration. However, the fact that there may be some additional costs involved in finding and using DBEs is not in itself sufficient reason for a proposer's failure to meet the contract DBE goal, as long as such costs are reasonable. Also, the ability or desire of a prime contractor to perform the work of a contract with its own organization does not relieve the Proposer of the responsibility to make good faith efforts. Proposing Design-Build Teams are not, however, required to accept higher quotes from DBEs if the price difference is excessive or unreasonable.

- (E) Not rejecting DBEs as being unqualified without sound reasons based on a thorough investigation of their capabilities. The Proposer's standing within its industry, membership in specific groups, organizations, or associates and political or social affiliations (for example, union vs. non-union employee status) are not legitimate causes for the rejection or non-solicitation of bids in the Proposer's efforts to meet the project goal.
- (F) Making efforts to assist interested DBEs in obtaining bonding, lines of credit, or insurance as required by the recipient or proposer.
- (G) Making efforts to assist interested DBEs in obtaining necessary equipment, supplies, materials, or related assistance or services.
- (H) Effectively using the services of available minority/women community organizations; minority/women contractors' groups; Federal, State, and local minority/women business assistance offices; and other organizations as allowed on a case-by-case basis to provide assistance in the recruitment and placement of DBEs. Contact within 7 days from the opening of the Price Proposals the Business Development Manager in the Business Opportunity and Work Force Development Unit to give notification of the Proposer's inability to get DBE quotes.
- (I) Any other evidence that the Proposer submits which shows that the Proposer has made reasonable good faith efforts to meet the DBE goal.

In addition, the Department may take into account the following:

- (1) Whether the Proposer's documentation reflects a clear and realistic plan for achieving the DBE goal.
- (2) The Proposer's past performance in meeting the DBE goals.
- (3) The performance of other proposers in meeting the DBE goal. For example, when the Proposer with the apparent adjusted low price fails to meet the DBE goal, but others meet it, you may reasonably raise the question of whether, with additional reasonable efforts the Proposer with the apparent adjusted low price could have met the goal. If the Proposer with the apparent adjusted low price fails to meet the DBE goal, but meets or exceeds the average DBE participation obtained by other proposers, the Department may view this, in conjunction with other factors, as evidence of the Proposer with the apparent adjusted low price having made a good faith effort.

If the Department does not award the contract to the Proposer with the apparent adjusted low price, the Department reserves the right to award the contract to the Proposer with the next adjusted lowest adjusted price that can satisfy to the Department that the DBE goal can be met or that an adequate good faith effort has been made to meet the DBE goal.

Non-Good Faith Appeal

The State Contractor Utilization Engineer will notify the Design-Build Team verbally and in writing of non-good faith. A Design-Build Team may appeal a determination of non-good faith made by the Goal Compliance Committee. If a Design-Build Team wishes to appeal the determination made by the Committee, they shall provide written notification to the State Contractual Services Engineer or at DBE@ncdot.gov. The appeal shall be made within 2 business days of notification of the determination of non-good faith.

Counting DBE Participation Toward Meeting DBE Goal

(A) Participation

The total dollar value of the participation by a committed DBE will be counted toward the contract goal requirement. The total dollar value of participation by a committed DBE will be based upon the value of work actually performed by the DBE and the actual payments to DBE firms by the Design-Build Team.

(B) Joint Checks

Prior notification of joint check use shall be required when counting DBE participation for services or purchases that involves the use of a joint check. Notification shall be through submission of Form JC-1 (*Joint Check Notification Form*) and the use of joint checks shall be in accordance with the Department's Joint Check Procedures.

(C) Subcontracts (Non-Trucking)

A DBE may enter into subcontracts. Work that a DBE subcontracts to another DBE firm may be counted toward the contract goal requirement. Work that a DBE subcontracts to a non-DBE firm does not count toward the contract goal requirement. If a DBE contractor or subcontractor subcontracts a significantly greater portion of the work of the contract than would be expected on the basis of standard industry practices, it shall be presumed that the DBE is not performing a commercially useful function. The DBE may present evidence to rebut this presumption to the Department. The Department's decision on the rebuttal of this presumption is subject to review by the Federal Highway Administration but is not administratively appealable to USDOT.

(D) Joint Venture

When a DBE performs as a participant in a joint venture, the Design-Build Team may count toward its contract goal requirement a portion of the total value of participation with the DBE in the joint venture, that portion of the total dollar value being a distinct clearly defined portion of work that the DBE performs with its forces.

(E) Suppliers

A Design-Build Team may count toward its DBE requirement 60 percent of its expenditures for materials and supplies required to complete the contract and obtained from a DBE regular dealer and 100 percent of such expenditures from a DBE manufacturer.

(F) Manufacturers and Regular Dealers

A Design-Build Team may count toward its DBE requirement the following expenditures to DBE firms that are not manufacturers or regular dealers:

- (1) The fees or commissions charged by a DBE firm for providing a *bona fide* service, such as providing bonds or insurance specifically required for the performance of a DOT-assisted contract, provided the fees or commissions are determined to be reasonable and not excessive as compared with fees and commissions customarily allowed for similar services.
- (2) With respect to materials or supplies purchased from a DBE, which is neither a manufacturer nor a regular dealer, count the entire amount of fees or commissions charged for assistance in the procurement of the materials and supplies, or fees or transportation charges for the delivery of materials or supplies required on a job site (but not the cost of the materials and supplies themselves), provided the fees are determined to be reasonable and not excessive as compared with fees customarily allowed for similar services.

Commercially Useful Function

(A) DBE Utilization

The Design-Build Team may count toward its contract goal requirement only expenditures to DBEs that perform a commercially useful function in the work of a contract. A DBE performs a commercially useful function when it is responsible for execution of the work of the contract and is carrying out its responsibilities by actually performing, managing, and supervising the work involved. To perform a commercially useful function, the DBE shall also be responsible with respect to materials and supplies used on the contract, for negotiating price, determining quality and quantity, ordering the material and installing (where applicable) and paying for the material itself. To determine whether a DBE is performing a commercially useful function, the Department will evaluate the amount of work subcontracted, industry practices, whether the amount the firm is to be paid under the contract is commensurate with the work it is actually performing and the DBE credit claimed for its performance of the work, and any other relevant factors.

(B) DBE Utilization in Trucking

The following factors will be used to determine if a DBE trucking firm is performing a commercially useful function.

- (1) The DBE shall be responsible for the management and supervision of the entire trucking operation for which it is responsible on a particular contract, and there shall not be a contrived arrangement for the purpose of meeting DBE goals.
- (2) The DBE shall itself own and operate at least one fully licensed, insured, and operational truck used on the contract.
- (3) The DBE receives credit for the total value of the transportation services it provides on the contract using trucks it owns, insures, and operates using drivers it employs.
- (4) The DBE may subcontract the work to another DBE firm, including an owner-operator who is certified as a DBE. The DBE who subcontracts work to another DBE receives credit for the total value of the transportation services the subcontracted DBE provides on the contract.
- (5) The DBE may also subcontract the work to a non-DBE firm, including from an owner-operator. The DBE who subcontracts the work to a non-DBE is entitled to credit for the total value of transportation services provided by the non-DBE subcontractor not to exceed the value of transportation services provided by DBE-owned trucks on the contract. Additional participation by non-DBE subcontractors receives credit only for the fee or commission it receives as a result of the subcontract arrangement. The value of services performed under subcontract agreements between the DBE and the Design-Build Team will not count towards the DBE contract requirement.
- (6) A DBE may lease truck(s) from an established equipment leasing business open to the general public. The lease must indicate that the DBE has exclusive use of and control over the truck. This requirement does not preclude the leased truck from working for others during the term of the lease with the consent of the DBE, so long as the lease gives the DBE absolute priority for use of the leased truck. This type of lease may count toward the DBE's credit as long as the driver is under the DBE's payroll.
- (7) Subcontracted/leased trucks shall display clearly on the dashboard the name of the DBE that they are subcontracted/leased to and their own company name if it is not identified on the truck itself. Magnetic door signs are not permitted.

DBE Replacement

When a Design-Build Team has relied on a commitment to a DBE firm (or an approved substitute DBE firm) to meet all or part of a contract goal requirement, the Design-Build Team shall not terminate the DBE for convenience. This includes, but is not limited to, instances in which the Design-Build Team seeks to perform the work of the terminated subcontractor with another DBE subcontractor, a non-DBE subcontractor, or with the Contractor's own forces or those of an affiliate. A DBE may only be terminated after receiving the Engineer's written approval based upon a finding of good cause for the termination.

All requests for replacement of a committed DBE firm shall be submitted to the Engineer for approval on Form RF-1 (*DBE Replacement Request*). If the Design-Build Team fails to follow this procedure, the Prime Contractor or other affiliated companies within the Design-build Team may be disqualified from further bidding for a period of up to 6 months.

The Design-Build Team shall comply with the following for replacement of a committed DBE:

(A) Performance Related Replacement

When a committed DBE is terminated for good cause as stated above, an additional DBE that was submitted at the time of bid may be used to fulfill the DBE commitment. A good faith effort will only be required for removing a committed DBE if there were no additional DBEs submitted at the time of bid to cover the same amount of work as the DBE that was terminated.

If a replacement DBE is not found that can perform at least the same amount of work as the terminated DBE, the Design-Build Team shall submit a good faith effort documenting the steps taken. Such documentation shall include, but not be limited to, the following:

- (1) Copies of written notification to DBEs that their interest is solicited in contracting the work defaulted by the previous DBE or in subcontracting other items of work in the contract.
- (2) Efforts to negotiate with DBEs for specific subbids including, at a minimum:
 - (a) The names, addresses, and telephone numbers of DBEs who were contacted.
 - (b) A description of the information provided to DBEs regarding the plans and specifications for portions of the work to be performed.
- (3) A list of reasons why DBE quotes were not accepted.
- (4) Efforts made to assist the DBEs contacted, if needed, in obtaining bonding or insurance required by the Design-Build Team.

(B) Decertification Replacement

- (1) When a committed DBE is decertified by the Department after the SAF (*Subcontract Approval Form*) has been received by the Department, the Department will not require the Design-Build Team to solicit replacement DBE participation equal to the remaining work to be performed by the decertified firm. The participation equal to the remaining work performed by the decertified firm will count toward the contract goal requirement.
- (2) When a committed DBE is decertified prior to the Department receiving the SAF (*Subcontract Approval Form*) for the named DBE firm, the Design-Build Team shall take all necessary and reasonable steps to replace the DBE subcontractor with another DBE subcontractor to perform at least the same amount of work to meet the DBE goal requirement. If a DBE firm is not found to do the same amount of work, a good faith effort must be submitted to NCDOT (see A herein for required documentation).

Changes in the Work

When the Engineer makes changes that result in the reduction or elimination of work to be performed by a committed DBE, the Design-Build Team will not be required to seek additional participation. When the Engineer makes changes that result in additional work to be performed by a DBE based upon the Design-Build Team's commitment, the DBE shall participate in additional work to the same extent as the DBE participated in the original contract work.

When the Engineer makes changes that result in extra work, which has more than a minimal impact on the contract amount, the Design-Build Team shall seek additional participation by DBEs unless otherwise approved by the Engineer.

When the Engineer makes changes that result in an alteration of plans or details of construction, and a portion or all of the work had been expected to be performed by a committed DBE, the Design-Build Team shall seek participation by DBEs unless otherwise approved by the Engineer.

When the Design-Build Team requests changes in the work that result in the reduction or elimination of work that the Design-Build Team committed to be performed by a DBE, the Design-Build Team shall seek additional participation by DBEs equal to the reduced DBE participation caused by the changes.

Reports and Documentation

A SAF (*Subcontract Approval Form*) shall be submitted for all work which is to be performed by a DBE subcontractor. The Department reserves the right to require copies of actual subcontract agreements involving DBE subcontractors.

When using transportation services to meet the contract commitment, the Design-Build Team shall submit a proposed trucking plan in addition to the SAF. The plan shall be submitted prior

to beginning construction on the project. The plan shall include the names of all trucking firms proposed for use, their certification type(s), the number of trucks owned by the firm, as well as the individual truck identification numbers, and the line item(s) being performed.

Within 30 calendar days of entering into an agreement with a DBE for materials, supplies or services, not otherwise documented by the SAF as specified above, the Design-Build Team shall furnish the Engineer a copy of the agreement. The documentation shall also indicate the percentage (60% or 100%) of expenditures claimed for DBE credit.

Reporting Disadvantaged Business Enterprise Participation

The Design-Build Team shall provide the Engineer with an accounting of payments made to all DBE firms, including material suppliers and contractors at all levels (prime, subcontractor, or second tier subcontractor). This accounting shall be furnished to the Engineer for any given month by the end of the following month. Failure to submit this information accordingly may result in the following action:

- (A) Withholding of money due in the next partial pay estimate; or
- (B) Removal of an approved Prime Contractor or other affiliated companies within the Design-Build Team from the prequalified bidders' list or the removal of other entities from the approved subcontractors list.

While each contractor (prime, subcontractor, 2nd tier subcontractor) is responsible for accurate accounting of payments to DBEs, it shall be the prime contractor's responsibility to report all monthly and final payment information in the correct reporting manner.

Failure on the part of the Design-Build Team to submit the required information in the time frame specified may result in the disqualification of that Prime Contractor and any affiliate companies within the Design-Build Team from further bidding until the required information is submitted.

Failure on the part of any subcontractor to submit the required information in the time frame specified may result in the disqualification of that Prime Contractor or any affiliate companies within the Design-Build Team from being approved for work on future DOT projects until the required information is submitted.

Design-Build Teams reporting transportation services provided by non-DBE lessees shall evaluate the value of services provided during the month of the reporting period only.

At any time, the Engineer can request written verification of subcontractor payments.

The Design-Build Team shall report the accounting of payments through the Department's DBE Payment Tracking System.

Failure to Meet Contract Requirements

Failure to meet contract requirements in accordance with Subarticle 102-15(J) of the 2012 *Standard Specifications for Roads and Structures* may be cause to disqualify the Prime Contractor or any affiliated companies within the Design-Build Team from further bidding for a specified length of time.

CERTIFICATION FOR FEDERAL-AID CONTRACTS

(3-21-90)

DB1 G85

The Proposer certifies, by signing and submitting a Design-Build Proposal, to the best of his or her knowledge and belief, that:

- (1) No Federal appropriated funds have been paid or will be paid, by or on behalf of the undersigned, to any person for influencing or attempting to influence an officer or employee of any Federal agency, a Member of Congress, an officer or employee of Congress, or an employee of a Member of Congress in connection with the awarding of any Federal contract, the making of any Federal grant, the making of any Federal loan, the entering into of any cooperative agreement, and the extension, continuation, renewal, amendment, or modification of any Federal contract, grant, loan, or cooperative agreement.
- (2) If any funds other than Federal appropriated funds have been paid or will be paid to any person for influencing or attempting to influence an officer or employee of any Federal agency, a Member of Congress, an officer or employee of Congress, or an employee of a Member of Congress in connection with this Federal contract, grant, loan, or cooperative agreement, the undersigned shall complete and submit Standard Form-LLL, *Disclosure Form to Report Lobbying*, in accordance with its instructions.

This certification is a material representation of fact upon which reliance was placed when this transaction was made or entered into. Submission of this certification is a prerequisite for making or entering into this transaction imposed by *Section 1352, Title 31, U.S. Code*. Any person who fails to file the required certification shall be subject to a civil penalty of not less than \$10,000 and not more than \$100,000 for each such failure.

The Proposer also agrees by submitting a Design-Build Proposal that he or she shall require that the language of this certification be included in all lower tier subcontracts, which exceed \$100,000 and that all such sub-recipients shall certify and disclose accordingly.

CONTRACTOR'S LICENSE REQUIREMENTS

(7-1-95)

DB1 G88

If the Design-Build Team does not hold the proper license to perform any plumbing, heating, air conditioning, or electrical work in this contract, he will be required to sublet such work to a contractor properly licensed in accordance with *Article 2 of Chapter 87 of the General Statutes* (licensing of heating, plumbing, and air conditioning contractors) and *Article 4 of Chapter 87 of the General Statutes* (licensing of electrical contractors).

U.S. DEPARTMENT OF TRANSPORTATION HOTLINE

(11-22-94)

DB1 G100

To report bid rigging activities call: **1-800-424-9071**

The U.S. Department of Transportation (DOT) operates the above toll-free *hotline* Monday through Friday, 8:00 a.m. to 5:00 p.m. eastern time. Anyone with knowledge of possible bid rigging, bidder collusion, or other fraudulent activities should use the *hotline* to report such activities.

The *hotline* is part of the DOT's continuing effort to identify and investigate highway construction contract fraud and abuse. It is operated under the direction of the DOT Inspector General. All information will be treated confidentially and caller anonymity will be respected.

SUBSURFACE INFORMATION

(3-22-07)

DB1 G119

Available subsurface information will be provided on this project. The Design-Build Team shall be responsible for additional investigations and for verifying the accuracy of the subsurface information supplied by the Department.

BID DOCUMENTATION

(1-1-02) (Rev. 10-19-10)

DB1 G142

General

The successful Design-Build Team shall submit the original, unaltered bid documentation or a certified copy of the original, unaltered bid documentation used to prepare the Price Proposal for this contract to the Department within 10 days after receipt of notice of award of contract. Such documentation shall be placed in escrow with a banking institution or other bonded document storage facility selected by the Department.

The Department will not execute the contract until the original, unaltered bid documentation or a certified copy of the original, unaltered bid documentation has been received by the Department.

Terms

Bid Documentation – Bid Documentation shall mean all written information, working papers, computer printouts, electronic media, charts, and all other data compilations which contain or reflect information, data, and calculations used by the Proposer in the preparation of the Price Proposal. The term *bid documentation* includes, but is not limited to, Design-Build Team equipment rates, Design-Build Team overhead rates, labor rates, efficiency or productivity factors, arithmetical calculations, and quotations from subcontractors and material suppliers to the extent that such rates and quotations were used by the Proposer in formulating and determining the Price Proposal. The term *bid documentation* also includes any manuals, which are standard to the industry used by the Proposer in determining the Price Proposal. Such manuals may be included in the bid documentation by reference. Such reference shall include

the name and date of the publication and the publisher. *Bid Documentation* does not include bid documents provided by the Department for use by the Proposer in bidding on this project.

Design-Build Team's Representative – Officer of the Prime Contractor's company; if not an officer, the Contractor shall supply a letter signed and notarized by an officer of the Prime Contractor's company, granting permission for the representative to sign the escrow agreement on behalf of the Prime Contractor.

Escrow Agent – Officer of the select banking institution or other bonded document storage facility authorized to receive and release bid documentation.

Escrow Agreement Information

A copy of the Escrow Agreement will be mailed to the Proposer with the notice of award for informational purposes. The Proposer and Department will sign the actual Escrow Agreement at the time the bid documentation is delivered to the escrow agent.

Failure to Provide Bid Documentation

The Proposer's failure to provide the original, unaltered bid documentation or a certified copy of the original, unaltered bid documentation within 10 days after the notice of award is received by him may be just cause for rescinding the award of the contract and may result in the removal of the Proposer from the Department's list of qualified bidders for a period of up to 180 days. Award may then be made to the Proposer with the next lowest adjusted price or the work may be readvertised and constructed under the contract or otherwise, as the Department may decide.

Submittal of Bid Documentation

- (A) Delivery - A representative of the Proposer shall deliver the original, unaltered bid documentation or a certified copy of the original, unaltered bid documentation to the Department, in a container suitable for sealing, within 10 days after the notice of award is received by him. Bid documentation will be considered a certified copy if the Proposer includes a letter to the Department from a chief officer of the company stating that the enclosed documentation is an *EXACT* copy of the original documentation. The letter shall be signed by a chief officer of the company, have the person's name and title typed below the signature, and the signature shall be notarized at the bottom of the letter.
- (B) Packaging – The container shall be no larger than 15.5 inches in length by 12 inches wide by 11 inches high and shall be water resistant. The container shall be clearly marked on the face and the back of the container with the following information: Bid Documentation, Proposer's Name, Proposer's Address, Date of Escrow Submittal, Contract Number, TIP Number if applicable, and County.

Affidavit

In addition to the bid documentation, an affidavit signed under oath by an individual authorized by the Proposer to execute the bid shall be included. The affidavit shall list each bid document with sufficient specificity so a comparison may be made between the list and the bid documentation to ensure that all of the bid documentation listed in the affidavit has been enclosed. The affidavit shall attest that the affiant has personally examined the bid documentation, that the affidavit lists all of the documents used by the Proposer to determine the Price Proposal for this project, and that all such bid documentation has been included.

Verification

Upon delivery of the bid documentation, the Department's Contract Officer and the Proposer's representative will verify the accuracy and completeness of the bid documentation compared to the affidavit. Should a discrepancy exist, the Proposer's representative shall immediately furnish the Department's Contract Officer with any other needed bid documentation. The Department's Contract Officer upon determining that the bid documentation is complete will, in the presence of the Proposer's representative, immediately place the complete bid documentation and affidavit in the container and seal it. Both parties will deliver the sealed container to the escrow agent for placement in a safety deposit box, vault, or other secure accommodation.

Confidentiality of Bid Documentation

The bid documentation and affidavit in escrow are, and will remain, the property of the Proposer. The Department has no interest in, or right to, the bid documentation and affidavit other than to verify the contents and legibility of the bid documentation unless the Design-Build Team gives written notice of intent to file a claim, files a written claim, files a written and verified claim, or initiates litigation against the Department. In the event of such written notice of intent to file a claim, filing of a written claim, filing a written and verified claim, or initiation of litigation against the Department, or receipt of a letter from the Design-Build Team authorizing release, the bid documentation and affidavit may become the property of the Department for use in considering any claim or in litigation as the Department may deem appropriate.

Any portion or portions of the bid documentation designated by the Proposer as a *trade secret* at the time the bid documentation is delivered to the Department's Contract Officer shall be protected from disclosure as provided by *G.S. 132-1.2*.

Duration and Use

The bid documentation and affidavit shall remain in escrow until 60 calendar days from the time the Contractor receives the final estimate; or until such time as the Design-Build Team:

- (A) Gives written notice of intent to file a claim,
- (B) Files a written claim,
- (C) Files a written and verified claim,
- (D) Initiates litigation against the Department related to the contract; or

- (E) Authorizes in writing its release.

Upon the giving of written notice of intent to file a claim, filing a written claim, filing a written and verified claim, or the initiation of litigation by the Design-Build Team against the Department, or receipt of a letter from the Design-Build Team authorizing release, the Department may obtain the release and custody of the bid documentation.

The Proposer certifies and agrees that the sealed container placed in escrow contains all of the bid documentation used to determine the Price Proposal and that no other bid documentation shall be relevant or material in litigation over claims brought by the Design-Build Team arising out of this contract.

Release of Bid Documentation to the Contractor

If the bid documentation remains in escrow 60 calendar days after the time the Design-Build Team receives the final estimate and the Design-Build Team has not filed a written claim, filed a written and verified claim, or has not initiated litigation against the Department related to the contract, the Department shall instruct the escrow agent to release the sealed container to the Prime Contractor.

The Contractor will be notified by certified letter from the escrow agent that the bid documentation will be released to the Contractor. The Contractor or his representative shall retrieve the bid documentation from the escrow agent within 30 days of the receipt of the certified letter. If the Contractor does not receive the documents within 30 days of the receipt of the certified letter, the Department will contact the Contractor to determine final dispersion of the bid documentation.

Payment

The cost of the escrow will be borne by the Department. There will be no separate payment for all costs of compilation of the data, container, or verification of the bid documentation. Payment at the various contract unit or lump sum prices in the contract will be full compensation for all such costs.

TWELVE MONTH GUARANTEE

(7-15-03)

DB1 G145

- (A) The Design-Build Team shall guarantee materials and workmanship against latent and patent defects arising from faulty materials, faulty workmanship or negligence for a period of twelve months following the date of final acceptance of the work for maintenance and shall replace such defective materials and workmanship without cost to the Department. The Design-Build Team will not be responsible for damage due to normal wear and tear, for negligence on the part of the Department, and / or for use in excess of the design.
- (B) Where items of equipment or material carry a manufacturer's guarantee for any period in excess of twelve months, then the manufacturer's guarantee shall apply for that particular

piece of equipment or material. The Department's first remedy shall be through the manufacturer although the Design-Build Team shall be responsible for invoking the warranted repair work with the manufacturer. The Design-Build Team's responsibility shall be limited to the term of the manufacturer's guarantee. NCDOT would be afforded the same warranty as provided by the Manufacturer.

This guarantee provision shall be invoked only for major components of work in which the Design-Build Team would be wholly responsible for under the terms of the contract. Examples would include pavement structures, bridge components, and sign structures. This provision will not be used as a mechanism to force the Design-Build Team to return to the project to make repairs or perform additional work that the Department would normally compensate the Design-Build Team for. In addition, routine maintenance activities (i.e. mowing grass, debris removal, ruts in earth shoulders,) are not parts of this guarantee.

Appropriate provisions of the payment and/or performance bonds shall cover this guarantee for the project. In addition, failure on the part of the responsible entity(ies) of the Design-Build Team to perform guarantee work within the terms of this provision shall be just cause to remove the responsible entity(ies) from the Department's corresponding prequalified list. The Design-Build Team will be removed for a minimum of 6 months and will be reinstated only after all work has been corrected and the Design-Build Team requests reinstatement in writing.

To ensure uniform application statewide the Division Engineer will forward details regarding the circumstances surrounding any proposed guarantee repairs to the Chief Engineer for review and approval prior to the work being performed.

EROSION & SEDIMENT CONTROL / STORMWATER CERTIFICATION

(1-16-07) (Rev 11-16-10)

DB1 G180

General

Schedule and conduct construction activities in a manner that will minimize soil erosion and the resulting sedimentation and turbidity of surface waters. Comply with the requirements herein regardless of whether or not a National Pollutant Discharge Elimination System (NPDES) permit for the work is required.

Establish a chain of responsibility for operations and subcontractors' operations to ensure that the *Erosion and Sediment Control / Stormwater Pollution Prevention Plan* is implemented and maintained over the life of the contract.

- (A) *Certified Supervisor* – Provide a certified Erosion and Sediment Control / Stormwater (E&SC/SW) Supervisor to manage the Design-Build Team and subcontractor(s) operations, ensure compliance with Federal, State and Local ordinances and regulations, and to manage the Quality Control Program.
- (B) *Certified Foreman* – Provide a certified, trained foreman for each construction operation that increases the potential for soil erosion or the possible sedimentation and turbidity of surface waters.

- (C) *Certified Installer* – Provide a certified installer to install or direct the installation for erosion and sediment control / stormwater practices.
- (D) *Certified Designer* – Provide a certified designer for the design of the erosion and sediment control / stormwater component of reclamation plans and, if applicable, for the design of the project erosion and sediment control / stormwater plan.

Roles and Responsibilities

- (A) *Certified Erosion and Sediment Control / Stormwater Supervisor* - The Certified Supervisor shall be Level II and responsible for ensuring erosion and sediment control / stormwater plan is adequately implemented and maintained on the project and for conducting the quality control program. The Certified Supervisor shall be on the project within 24 hours notice from initial exposure of an erodible surface to the project's final acceptance. Perform the following duties:
 - (1)
 - (a) Manage Operations - Coordinate and schedule the work of subcontractors so that erosion and sediment control / stormwater measures are fully executed for each operation and in a timely manner over the duration of the contract.
 - (b) Prepare the required National Pollutant Discharge Elimination System (NPDES) Inspection Record and submit to the Engineer.
 - (c) Attend all weekly or monthly construction meetings to discuss the findings of the NPDES inspection and other related issues.
 - (d) Implement the erosion and sediment control / stormwater site plans requested.
 - (e) Provide any needed erosion and sediment control / stormwater practices for the Design-Build Team's temporary work not shown on the plans, such as, but not limited to work platforms, temporary construction, pumping operations, plant and storage yards, and cofferdams.
 - (f) Acquire applicable permits and comply with requirements for borrow pits, dewatering, and any temporary work conducted by the Design-Build Team in jurisdictional areas.
 - (g) Conduct all erosion and sediment control / stormwater work in a timely and workmanlike manner.
 - (h) Fully perform and install erosion and sediment control / stormwater work prior to suspension of the work.
 - (i) Coordinate with Department, Federal, State and Local Regulatory agencies on resolution of erosion and sediment control / stormwater issues due to the Design-Build Team's operations.
 - (j) Ensure that proper cleanup occurs from vehicle tracking on paved surfaces and / or any location where sediment leaves the Right-of-Way.
 - (k) Have available a set of erosion and sediment control/stormwater plans that are initialed and include the installation date of Best Management

Practices. These practices shall include temporary and permanent groundcover and be properly updated to reflect necessary plan and field changes for use and review by Department personnel as well as regulatory agencies.

- (2) Requirements set forth under the NPDES Permit – The Department's NPDES Stormwater permit (NCS000250) outlines certain objectives and management measures pertaining to construction activities. The permit references *NCG010000, General Permit to Discharge Stormwater* under the NPDES, and states that the Department shall incorporate the applicable requirements into its delegated Erosion and Sediment Control Program for construction activities disturbing one or more acres of land. The Department further incorporates these requirements on all contracted bridge and culvert work at jurisdictional waters, regardless of size. Some of the requirements are, but are not limited to:
 - (a) Control project site waste to prevent contamination of surface or ground waters of the state, i.e. from equipment operations/maintenance construction materials, concrete washout, chemicals, litter, fuels, lubricants, coolants, hydraulic fluids, any other petroleum products, and sanitary waste.
 - (b) Inspect erosion and sediment control / stormwater devices and stormwater discharge outfalls at least once every 7 calendar days, twice weekly for construction related Federal Clean Water Act, Section 303(d) impaired streams with turbidity violations, and within 24 hours after a significant rainfall event of 0.5 inches within a 24-hour period.
 - (c) Maintain an onsite rain gauge or use the Department's Multi-Sensor Precipitation Estimate website to maintain a daily record of rainfall amounts and dates.
 - (d) Maintain erosion and sediment control / stormwater inspection records for review by Department and Regulatory personnel upon request.
 - (e) Implement approved reclamation plans on all borrow pits, waste sites and staging areas.
 - (f) Maintain a log of turbidity test results as outlined in the Department's Procedure for Monitoring Borrow Pit Discharge.
 - (g) Provide secondary containment for bulk storage of liquid materials.
 - (h) Provide training for employees concerning general erosion and sediment control / stormwater awareness, the Department's NPDES Stormwater Permit NCS000250 requirements, and the requirements of the *General Permit, NCG010000*.
 - (i) Report violations of the NPDES permit to the Engineer immediately who will notify the Division of Water Quality Regional Office within 24 hours of becoming aware of the violation.
- (3) Quality Control Program - Maintain a quality control program to control erosion, prevent sedimentation and follow provisions/conditions of permits. The quality control program shall:

- (a) Follow permit requirements related to the Design-Build Team and subcontractors' construction activities.
 - (b) Ensure that all operators and / or subcontractor(s) on site have the proper erosion and sediment control / stormwater certification.
 - (c) Notify the Engineer when the required certified erosion and sediment control / stormwater personnel are not available on the job site when needed.
 - (d) Conduct the inspections required by the NPDES permit.
 - (e) Take corrective actions in the proper timeframe as required by the NPDES permit for problem areas identified during the NPDES inspections.
 - (f) Incorporate erosion control into the work in a timely manner and stabilize disturbed areas with mulch / seed or vegetative cover on a section-by-section basis.
 - (g) Use flocculants approved by state regulatory authorities where appropriate and where required for turbidity and sedimentation reduction.
 - (h) Ensure proper installation and maintenance of temporary erosion and sediment control devices.
 - (i) Remove temporary erosion or sediment control devices when they are no longer necessary as agreed upon by the Engineer.
 - (j) The Design-Build Team's quality control and inspection procedures shall be subject to review by the Engineer. Maintain NPDES inspection records and make records available at all times for verification by the Engineer.
- (B) *Certified Foreman* - At least one Certified Foreman shall be onsite for each type of work listed herein during the respective construction activities to control erosion, prevent sedimentation and follow permit provisions:
- (1) Foreman in charge of grading activities
 - (2) Foreman in charge of bridge or culvert construction over jurisdictional areas
 - (3) Foreman in charge of utility activities

The Design-Build Team may request to use the same person as the Level II Supervisor and Level II Foreman. This person shall be onsite whenever construction activities as described above are taking place. This request shall be approved by the Engineer prior to work beginning.

The Design-Build Team may request to name a single Level II Foreman to oversee multiple construction activities on small bridge or culvert replacement projects. This request shall be approved by the Engineer prior to work beginning.

- (C) *Certified Installers* - Provide at least one onsite, Level I Certified Installer for each of the following erosion and sediment control / stormwater crew:

- (1) Seeding and Mulching
- (2) Temporary Seeding
- (3) Temporary Mulching
- (4) Sodding
- (5) Silt fence or other perimeter erosion / sediment control device installations
- (6) Erosion control blanket installation
- (7) Hydraulic tackifier installation
- (8) Turbidity curtain installation
- (9) Rock ditch check / sediment dam installation
- (10) Ditch liner / matting installation
- (11) Inlet protection
- (12) Riprap placement
- (13) Stormwater BMP installations (such as but not limited to level spreaders, retention / detention devices)
- (14) Pipe installations within jurisdictional areas

If a Level I *Certified Installer* is not onsite, the Design-Build Team may substitute a Level II Foreman for a Level I Installer, provided the Level II Foreman is not tasked to another crew requiring Level II Foreman oversight.

- (D) *Certified Designer* – Include the certification number of the Level III-B Certified Designer on the erosion and sediment control / stormwater component of all reclamation plans and if applicable, the certification number of the Level III-A Certified Designer on the design of the project erosion and sediment control / stormwater plan.

Preconstruction Meeting

Furnish the names of the *Certified Erosion and Sediment Control / Stormwater Supervisor, Certified Foremen, Certified Installers and Certified Designers* and notify the Engineer in writing of changes in certified personnel over the life of the contract within 2 days of change.

Ethical Responsibility

Any company performing work for the North Carolina Department of Transportation has the ethical responsibility to fully disclose any reprimand or dismissal of an employee resulting from improper testing or falsification of records.

Revocation or Suspension of Certification

Upon recommendation of the Chief Engineer - Operations to the certification entity, certification for Supervisor, Certified Foreman, Certified Installer and Certified Designer may be revoked or suspended with the issuance of an Immediate Corrective Action (ICA), Notice of Violation (NOV), or Cease and Desist Order for erosion and sediment control / stormwater related issues.

The Chief Engineer may recommend suspension or permanent revocation of such certification due to the following:

- (A) Failure to adequately perform the duties as defined within the certification provision
- (B) Issuance of an ICA, NOV, or Cease and Desist Order
- (C) Failure to fully perform environmental commitments as detailed within the permit conditions and specifications
- (D) Demonstration of erroneous documentation or reporting techniques
- (E) Cheating or copying another candidate's work on an examination
- (F) Intentional falsification of records
- (G) Directing a subordinate under direct or indirect supervision to perform any of the above actions
- (H) Dismissal from a company for any of the above reasons
- (I) Suspension or revocation of one's certification by another entity

Suspension or revocation of a certification will be sent by certified mail to the certificant and the Corporate Head of the company that employs the certificant.

A certificant has the right to appeal any adverse action which results in suspension or permanent revocation of certification by responding, in writing, to the Chief Engineer within 10 calendar days after receiving notice of the proposed adverse action.

Chief Engineer - Operations
1537 Mail Service Center
Raleigh, NC 27699-1537

Failure to appeal within 10 calendar days will result in the proposed adverse action becoming effective on the date specified on the certified notice. Failure to appeal within the time specified will result in a waiver of all future appeal rights regarding the adverse action taken. The certificant will not be allowed to perform duties associated with the certification during the appeal process.

The Chief Engineer will hear the appeal and make a decision within 7 days of hearing the appeal. The decision of the Chief Engineer will be final and will be made in writing to the certificant.

If a certification is temporarily suspended, the certificant shall pass any applicable written examination and any proficiency examination, at the conclusion of the specified suspension period, prior to having the certification reinstated.

Measurement and Payment

Certified Erosion and Sediment Control / Stormwater Supervisor, Certified Foremen, Certified Installers and Certified Designer will be incidental to the project for which no direct compensation will be made.

PROCEDURE FOR MONITORING BORROW PIT DISCHARGE

(2-20-07)

DB1 G181

Water discharge from borrow pit sites shall not cause surface waters to exceed 50 NTUs (nephelometric turbidity unit) in streams not designated as trout waters and 10 NTUs in streams, lakes or reservoirs designated as trout waters. For lakes and reservoirs not designated as trout waters, the turbidity shall not exceed 25 NTUs. If the turbidity exceeds these levels due to natural background conditions, the existing turbidity level shall not be increased.

If during any operating day, the downstream water quality exceeds the standard, the Design-Build Team shall do all of the following:

- (A) Either cease discharge or modify the discharge volume or turbidity levels to bring the downstream turbidity levels into compliance, or
- (B) Evaluate the upstream conditions to determine if the exceedance of the standard is due to natural background conditions. If the background turbidity measurements exceed the standard, operation of the pit and discharge can continue as long as the stream turbidity levels are not increased due to the discharge.
- (C) Measure and record the turbidity test results (time, date and sampler) at all defined sampling locations 30 minutes after startup and at a minimum, one additional sampling of all sampling locations during that 24-hour period in which the borrow pit is discharging.
- (D) Notify DWQ within 24 hours of any stream turbidity standard exceedances that are not brought into compliance.

During the Environmental Assessment required by Article 230-4 of the 2012 *Standard Specifications for Roads and Structures*, the Design-Build Team shall define the point at which the discharge enters into the State's surface waters and the appropriate sampling locations. Sampling locations shall include points upstream and downstream from the point at which the discharge enters these waters. Upstream sampling location shall be located so that it is not influenced by backwater conditions and represents natural background conditions. Downstream sampling location shall be located at the point where complete mixing of the discharge and receiving water has occurred.

The discharge shall be closely monitored when water from the dewatering activities is introduced into jurisdictional wetlands. Any time visible sedimentation (deposition of sediment) on the wetland surface is observed, the dewatering activity shall be suspended until turbidity levels in the stilling basin can be reduced to a level where sediment deposition does not occur. Staining of wetland surfaces from suspended clay particles, occurring after evaporation or infiltration, does not constitute sedimentation. No activities shall occur in wetlands that adversely affect the functioning of a wetland. Visible sedimentation shall be considered an indication of possible adverse impacts on wetland use.

The Engineer shall perform independent turbidity tests on a random basis. These results shall be maintained in a log within the project records. Records will include, at a minimum, turbidity test

results, time, date and name of sampler. Should the Department's test results exceed those of the Design-Build Team's test results, an immediate test shall be performed jointly with the results superseding the previous test results of both the Department and the Design-Build Team.

The Design-Build Team shall use the *NCDOT Turbidity Reduction Options for Borrow Pits Matrix*, available at <http://www.ncdot.org/doh/preconstruct/ps/contracts/letting.html> to plan, design, construct, and maintain BMPs to address water quality standards. Tier I Methods include stilling basins which are standard compensatory BMPs. Other Tier I methods are noncompensatory and shall be used when needed to meet the stream turbidity standards. Tier II Methods are also noncompensatory and are options that may be needed for protection of rare or unique resources or where special environmental conditions exist at the site which have led to additional requirements being placed in the DWQ's 401 Certifications and approval letters, Isolated Wetland Permits, Riparian Buffer Authorization or a DOT Reclamation Plan's Environmental Assessment for the specific site. Should the Design-Build Team exhaust all Tier I Methods on a site exclusive of rare or unique resources or special environmental conditions, Tier II Methods may be required by regulators on a case by case basis per supplemental agreement.

The Design-Build Team may use cation exchange capacity (CEC) values from proposed site borings to plan and develop the Price Proposal for the project. CEC values exceeding 15 milliequivalents per 100 grams of soil may indicate a high potential for turbidity and should be avoided when dewatering into surface water is proposed.

No additional compensation for monitoring borrow pit discharge will be paid.

CLEARING AND GRUBBING

(09-1-11)

DB2 R01

With the exception of areas with Permanent Utility Easements, perform clearing on this project to the limits established by Method "III" shown on Standard No. 200.03 of the 2012 *NCDOT Roadway Standard Drawings*. In areas with Permanent Utility Easements, clearing shall extend to the Right of Way limits.

BURNING RESTRICTIONS

(7-1-95)

DB2 R05

Open burning is not permitted on any portion of the right of way limits established for this project. The Design-Build Team shall not burn the clearing, grubbing or demolition debris designated for disposal and generated from the project at locations within the project limits, off the project limits or at any waste or borrow sites in Mecklenburg County. The Design-Build Team shall dispose of the clearing, grubbing and demolition debris by means other than burning and in accordance with state and local rules and regulations.

CEMENT AND LIME STABILIZATION OF SUB-GRADE SOILS

(9-1-11)

DB5 R21

General

The Design-Build Team shall be responsible for the following:

1. Performing all laboratory tests in a laboratory certified by the AMRL / NCDOT Laboratory Proficiency Program
2. Sampling Sub-grade soils
3. Conducting Laboratory tests to determine:
 - a. Soil classifications
 - b. Moisture-density relationships
 - c. Quantity of lime or cement required to achieve specified strengths
4. Designating areas to be stabilized by either lime or cement and the required rates of application
5. Conducting field tests to determine unconfined compressive strength

Sampling

The Design-Build Team shall take soil samples, after the project has been graded to within 2 inches of final sub-grade elevation. The Design-Build Team shall sample the top 8 inches at a minimum frequency of one sample per 1,000 feet, per each lane, for classification tests; and one sample per 3,000 feet, per each lane, for moisture density tests and lime or cement mix design tests. Additional samples shall be taken to ensure that all the predominant soil types, limits of distribution of these soils and different site conditions have been represented.

Classification Tests

The Design-Build Team shall perform the following tests to determine AASHTO classifications of different soils in accordance with AASHTO specifications as modified by NCDOT. Copies of these modified procedures can be obtained from Materials and Test Unit's Soils Laboratory.

TABLE 1

<u>TEST</u>	<u>AASHTO DESIGNATION</u>
Dry Preparation of Disturbed Soils	T-87
Particle Size Analysis of Soils	T-88
Determining the Liquid Limit of Soils	T-89
Determining the Plastic Limit and Plasticity Index of Soils	T-90

Moisture Density Test

Based on the criteria set in Table 2, below, the Design-Build Team shall perform the Moisture Density Tests, using either lime or cement. The Design-Build Team shall use 10% cement by weight in soil cement and 4% lime by weight, in soil-lime mixtures. The Design-Build Team shall conduct the tests in accordance with AASHTO T-99, and T-134 for soil-lime and soil-cement mixtures, respectively. In each case, The Design-Build Team shall determine the maximum dry density and optimum moisture content.

TABLE 2

CRITERIA FOR SELECTING LIME OR CEMENT		
PROPERTY	A	B
Percent passing #200 Sieve	35 Max	36 Min
Liquid Limit	40 Max	41 Min
Plasticity Index	10 Max	25 Min

The Design-Build Team shall use cement for all soils meeting criteria in Column A and lime for all soils meeting criteria in Column B. The Design-Build Team may choose either lime or cement for all soils not meeting all criteria in either Column A or B.

DETERMINING THE APPLICATION RATES FOR SOIL-CEMENT AND SOIL-LIME MIXTURES

Soil-Cement Mixtures

For soil-cement mixtures, the Design-Build Team shall be required to do the following:

- Make specimens at optimum moisture content using a quantity of cement in the range of 5 to 12 percent by weight.
- Compact the specimens to a minimum density of 95% of maximum dry density obtained using AASHTO T 134.
- Make a minimum of 2 specimens for each selected cement rate.
- Cure the specimens for 7 days in a moist room maintained at a temperature of 73°F ±2.7° and a humidity of 100%. At the end of the curing period, immerse the specimens in water for 4 hours.

- After immersion, test the specimens in unconfined compression in accordance with ASTM D 1633.
- Report the maximum strength obtained and the corresponding percent strain.
- Select the rate of cement that provides a minimum unconfined compressive strength of 200 psi and a maximum of 400 psi.

Soil-Lime Mixtures

For soil-lime mixtures, the Design-Build Team shall be required to do the following:

- Make specimens at optimum moisture content using a quantity of lime in the range of 3.5 to 6.5 percent by weight.
- Compact specimens to a minimum density of 95% of maximum dry density obtained by AASHTO T99.
- Make a minimum of two specimens for each selected lime rate.
- Cure the specimens in sealed plastic bags for 48 hours in an oven at a temperature of 118 °F. Do not immerse the specimens in water at the end of the curing period.
- Test the specimens in unconfined compression in accordance with AASHTO T 208. Report the maximum strength obtained and the corresponding percent strain.
- Select the rate of lime that provides a minimum unconfined compressive strength of 60 psi.

Submittals for Review and Approval Prior to Construction

The Design-Build Team shall adhere to the following submittal guidelines:

- Submit all laboratory test results for review.
- Submit a sketch in plan view showing areas of the project to be stabilized by either lime or cement and application rates for each stabilizer.
- Submit any other documentation that supports the Design-Build Team's recommendations.

Construction of Lime Treated Subgrade

The Design-Build Team shall construct the lime treated sub-grade as specified in Section 501 of the North Carolina Department of Transportation *2012 Standard Specifications for Roads and Structures* with the following exceptions:

Subarticle 501-4 Equipment

Contractor's equipment will not require engineer's approval.

Subarticle 501-8 (A) General

Paragraph #1 is not applicable to this project.

Subarticle 501-9 (B) Preliminary Curing

Amend as follows: Allow a minimum of 2 days and a maximum of 4 days for preliminary curing.

Subarticle 501-10 Compacting, Shaping, and Finishing

Last paragraph is not applicable.

Subarticle 501-11 Thickness

Last two paragraphs are not applicable.

Construction of Cement Treated Subgrade

The Design-Build Team shall construct the soil cement sub-grade as specified in section 542 of the *2012 Standard Specifications for Roads and Structures*, with the following exceptions:

Subarticle 542-4 Equipment

Contractor's equipment will not require Engineer's approval.

Subarticle 542-7 Application of Cement

First paragraph is not applicable.

Subarticle 542-11 Thickness

Paragraphs 2 and 3 are not applicable.

Unconfined Compressive Strength

The lime-stabilized subgrades shall be tested using Dynamic Cone Penetrometer (DCP) and/or by making field specimens. DCP testing shall be in accordance with *Quality Assurance Testing of Lime-Treated Soils Utilizing the Dynamic Cone Penetrometer*, Test Method #1-2005. The Design-Build Team shall adhere to the testing equipment requirements and procedures as outlined in *Dynamic Cone Penetrometer Testing for Subgrade Stability* except that the minimum penetration depth shall be eight inches. Upon request, a copy of the aforementioned documents can be obtained from the NCDOT Geotechnical Engineering Unit. The required unconfined compressive strength for lime shall be 60 psi, which corresponds to a penetration per blow of approximately 0.5 inches of the Dynamic Cone Penetrometer. If field specimens are made, cure them for seven days and test them in the laboratory. The minimum required unconfined compressive strength for lime-stabilized subgrade shall be 60 psi.

For cement-stabilized subgrades, the Design-Build Team shall make field specimens, cure them for seven days and test them in the laboratory. The minimum and maximum required unconfined compressive strength for soil cement shall be 200 psi and 400 psi, respectively.

For both lime and cement stabilized subgrades, one test shall be required for every 400 feet per lane width at random locations selected using random number tables.

Submittals for Review During Construction

The Design-Build Team shall submit the unconfined compressive strength and dynamic cone penetrometer test results for review and acceptance.

PRICE ADJUSTMENTS FOR ASPHALT BINDER

(9-1-11)

DB6 R25

Price adjustments for asphalt binder for plant mix will be made in accordance with Section 620 of the 2012 *Standard Specifications for Roads and Structures*.

When it is determined that the monthly selling price of asphalt binder on the first business day of the calendar month during which the last day of the partial payment period occurs varies either upward or downward from the Base Price Index, the partial payment for that period will be adjusted. The partial payment will be adjusted by adding the difference (+ or -) of the base price index subtracted from the monthly selling price multiplied by the total theoretical quantity of asphalt binder authorized for use in the plant mix placed during the partial payment period involved.

The base price index for asphalt binder for plant mix is \$ **PRICE TO BE INCLUDED IN THE FINAL RFP** per ton.

This base price index represents an average of F.O.B. selling prices of asphalt binder at supplier's terminals on .

PRICE ADJUSTMENTS - ASPHALT CONCRETE PLANT MIX

(9-1-11)

DB6 R26

Revise the 2012 *Standard Specifications for Roads and Structures* as follows:

Page 6-18, Article 609-11 and Page 6-35, Article 610-14

Add the following paragraph before the first paragraph:

The “Asphalt Price” used to calculate any price adjustments set forth in this section shall be \$35 per theoretical ton. This price shall apply for all mix types.

FIELD OFFICE

(9-07-11)

DB 08-01

Description

This work consists of furnishing, erecting, equipping, and maintaining a field office for the exclusive use of Department Engineers and Inspectors at a location on the project approved by the Engineer. Provide a field office that complies with the current A.D.A. Design and Accessibility Standards, the National Electric Code, local, state, and federal regulations, and the following:

Procedures

The field office and equipment remains the property of the Design Build Team. The field office must be separated from buildings and trailers used by the Design Build Team, contained within a fenced area, and be erected and functional as an initial operation. Failure to have the field office functional when utility relocation work first begins on the project will result in withholding payment of the Design Build Team's monthly progress estimate. The field office must be operational throughout the duration of the project and be removed upon completion and final acceptance of the project or until notified by NCDOT that it is no longer needed. Thirty (30) days written notice will be given by NCDOT if the office is to be removed prior to the end of the project.

Materials and Sizes

The field office must be weatherproof, tightly floored/roofed, supported above the ground, have a minimum width of 24 feet, minimum floor to ceiling height of 7 feet 6 inches, walls and ceilings constructed of suitable material, insulated exterior, and have a floor space of at least 1500 square feet.

Windows and Doors

Provide at least three windows each having an area of at least 540 square inches, capable of being opened and secured from the inside and having at least two exterior passage doors of at least 30 inches in width and 78 inches in height. Equip exterior passage doors with locks and furnish at least two keys. Lighted emergency exit signs must be on each door.

Steps

Provide accessibility in compliance with the current ADA. Design and Accessibility Standards, and the State Building Code and maintain them free from obstructions.

Storage Facility for Nuclear Gauge

NCDOT will furnish two locking storage facilities (old signal cabinets) for the Department's nuclear gauges. A concrete pad(s) with bolts for securing the cabinets shall be provided with the field office, not to be located within 10 feet of any other structure.

Lighting, Heating, and Air Conditioning

The field office must have satisfactory lighting, electrical outlets, heating equipment, exhaust fans (toilets), and an air conditioner connected to an operational power source. Provide at least one fluorescent light fixture over a plan / drafting table. Furnish electrical current and/or fuel for the heating equipment, stove, and refrigerator.

Fire Extinguishers

Furnish and maintain one fire extinguisher for each required exterior passage door. Fire extinguisher(s) may be chemical or dry powder. UL Classification 10-B:C (minimum), suitable for Type A:B:C: fires. Mount and maintain fire extinguisher(s) in accordance with OSHA Safety and Health Standards.

Toilets

Provide Mens /Womens facilities conforming to the requirements of the state and local boards of health. Provide an adequate locking system on the inside of the doors. Maintain a water supply and sewer connection for the duration of the project.

Utilities

Provide all utility connections (water, sewer, power, phone, and heating fuel if necessary) and pay all associated bills.

Storage Facility for Test Equipment

Provide the field office with a storage facility, separate from the office for storage of test equipment, other than the nuclear gage. Provide a facility that has a minimum floor space of 64 square feet, is weatherproof, tightly floored and roofed, and has a tamper resistant key operated lock.

Equipment

Provide a field office that is equipped with the following:

<u>Number</u>	<u>Item</u>
2	Double-pedestal desk (approximately 60 by 34 inches, at least 2,000 square inches)
1	Plan and drafting table (approximately 30 by 96 inches) with adjustable stool
1	Computer table having a minimum size of 48 by 30 by 29 inches
1	Plan rack for 24 by 36 inch drawings with 6 plan clamps
1	Printing calculator
2	2-drawer fire protection file, 15 in. drawer width, min. UL rating of C1 350

8	Office chairs with casters
2	Wastebaskets
1	Pencil sharpener
1	Copy machine (8-1/2 inch x 11 inch & 11 inch x 17 inch copies)
1	Ice machine
1	Printer/ scanner combination machine
2	Telephones
1	Fax machine

All equipment to be approved by the Engineer. Provide a small kitchen stove and refrigerator for use by Department Engineers and Inspectors. The equipment will be maintained or replaced as needed until removal of the field office.

Miscellaneous Items

The field office must also include the following:

1. A certification that the office is free of asbestos and other hazardous materials
2. A broom, dust pan, mop and bucket, and general cleaning supplies
3. Provide and maintain an all-weather parking area for a minimum of fifteen vehicles, including graveled access to the paved surface

FOUNDATIONS AND ANCHOR ROD ASSEMBLIES FOR METAL POLES

(9-1-11)

DB9 R05

Description

Foundations for metal poles include foundations for signals, cameras, overhead and dynamic message signs (DMS) and high mount and low level light standards supported by metal poles or upright trusses. Foundations consist of footings with pedestals and drilled piers with or without grade beams or wings. Anchor rod assemblies consist of anchor rods (also called anchor bolts) with nuts and washers on the exposed ends of rods and nuts and a plate or washers on the other ends of rods embedded in the foundation.

Construct concrete foundations with the required resistances and dimensions and install anchor rod assemblies in accordance with the contract and accepted submittals. Construct drilled piers consisting of cast-in-place reinforced concrete cylindrical sections in excavated holes. Provide temporary casings or polymer slurry as needed to stabilize drilled pier excavations. Use a prequalified Drilled Pier Contractor to construct drilled piers for metal poles. Define “excavation” and “hole” as a drilled pier excavation and “pier” as a drilled pier.

This provision does not apply to materials and anchor rod assemblies for standard foundations for low level light standards. See Section 1405 of the 2012 *Standard Specifications for Roads and Structures* and *Roadway Standard Drawings* No. 1405.01 for materials and anchor rod assemblies for standard foundations. For construction of standard foundations for low level light standards, standard foundations are considered footings in this provision.

This provision does not apply to foundations for signal pedestals; see Section 1743 of the 2012 *Standard Specifications for Roads and Structures* and *Roadway Standard Drawings* No. 1743.01.

Materials

Refer to the 2012 *Standard Specifications for Roads and Structures*.

Item	Section
Conduit	1091-3
Grout, Nonshrink	1003
Polymer Slurry	411-2(B)
Portland Cement Concrete	1000
Reinforcing Steel	1070
Rollers and Chairs	411-2(C)
Temporary Casings	411-2(A)

Provide Type 3 material certifications in accordance with Article 106-3 of the 2012 *Standard Specifications for Roads and Structures* for conduit, rollers, chairs and anchor rod assemblies. Store steel materials on blocking at least 12" above the ground and protect it at all times from damage; and when placing in the work make sure it is free from dirt, dust, loose mill scale, loose rust, paint, oil or other foreign materials. Load, transport, unload and store foundation and anchor rod assembly materials so materials are kept clean and free of damage. Damaged or deformed materials will be rejected.

Use conduit type in accordance with the contract. Use Class A concrete for footings and pedestals, Class Drilled Pier concrete for drilled piers and Class AA concrete for grade beams and wings including portions of drilled piers above bottom of wings elevations. Corrugated temporary casings may be accepted at the discretion of the Engineer. A list of approved polymer slurry products is available from:

www.ncdot.org/doh/preconstruct/highway/geotech/leftmenu/Polymer.html

Provide anchor rod assemblies in accordance with the contract consisting of the following:

- (A) Straight anchor rods,
- (B) Heavy hex top and leveling nuts and flat washers on exposed ends of rods, and
- (C) Nuts and either flat plates or washers on the other ends of anchor rods embedded in foundations.

Do not use lock washers. Use steel anchor rods, nuts and washers that meet ASTM F1554 for Grade 55 rods and Grade A nuts. Use steel plates and washers embedded in concrete with a nominal thickness of at least 1/4". Galvanize anchor rods and exposed nuts and washers in accordance with Article 1076-4 of the 2012 *Standard Specifications for Roads and Structures*. It is not necessary to galvanize nuts, plates and washers embedded in concrete.

Construction Methods

Install the required size and number of conduits in foundations in accordance with the accepted plans developed by the Design-Build Team and accepted submittals. Construct top of piers, footings, pedestals, grade beams and wings flat, level and within 1" of elevations shown in the accepted plans or approved by the Engineer. Provide an Ordinary Surface finish in accordance with Subarticle 825-6(B) of the 2012 *Standard Specifications for Roads and Structures* for portions of foundations exposed above finished grade. Do not remove anchor bolt templates or pedestal or grade beam forms or erect metal poles or upright trusses onto foundations until concrete attains a compressive strength of at least 3,000 psi.

Drilled Piers

Before starting drilled pier construction, hold a predrill meeting to discuss the installation, monitoring and inspection of the drilled piers. Schedule this meeting after the Drilled Pier Contractor has mobilized to the site. The Resident or Division Traffic Engineer, Contractor and Drilled Pier Contractor Superintendent will attend this predrill meeting.

Do not excavate holes, install piles or allow equipment wheel loads or vibrations within 20 ft of completed piers until 16 hours after Drilled Pier concrete reaches initial set.

Check for correct drilled pier alignment and location before beginning drilling. Check plumbness of holes frequently during drilling.

Construct drilled piers with the minimum required diameters shown in the accepted plans developed by the Design-Build Team. Install piers with tip elevations no higher than shown in the plans or approved by the Engineer.

Excavate holes with equipment of the sizes required to construct drilled piers. Depending on the subsurface conditions encountered, drilling through rock and boulders may be required. Do not use blasting for drilled pier excavations.

Contain and dispose of drilling spoils and waste concrete as directed and in accordance with Section 802 of the 2012 *Standard Specifications for Roads and Structures*. Drilling spoils consist of all materials and fluids removed from excavations.

If unstable, caving or sloughing materials are anticipated or encountered, stabilize holes with temporary casings and/or polymer slurry. Do not use telescoping temporary casings. If it becomes necessary to replace a temporary casing during drilling, backfill the excavation, insert a larger casing around the casing to be replaced or stabilize the excavation with polymer slurry before removing the temporary casing.

If temporary casings become stuck or the Design-Build Team proposes leaving casings in place, temporary casings should be installed against undisturbed material. Unless otherwise approved, do not leave temporary casings in place for mast arm poles and cantilever signs. The Engineer will determine if casings may remain in place. If the

Contractor proposes leaving temporary casings in place, do not begin drilling until a casing installation method is approved.

Use polymer slurry and additives to stabilize holes in accordance with the slurry manufacturer's recommendations. Provide mixing water and equipment suitable for polymer slurry. Maintain polymer slurry at all times so slurry meets Table 411-3 of the 2012 *Standard Specifications for Roads and Structures* except for sand content.

Define a "sample set" as slurry samples collected from mid-height and within 2 ft of the bottom of holes. Take sample sets from excavations to test polymer slurry immediately after filling holes with slurry, at least every 4 hours thereafter and immediately before placing concrete. Do not place Drilled Pier concrete until both slurry samples from an excavation meet the required polymer slurry properties. If any slurry test results do not meet the requirements, the Engineer may suspend drilling until both samples from a sample set meet the required slurry properties.

Remove soft and loose material from bottom of holes using augers to the satisfaction of the Engineer. Assemble rebar cages and place cages and Drilled Pier concrete in accordance with Subarticle 411-4(E) except for the following:

- (1) Inspections for tip resistance and bottom cleanliness are not required,
- (2) Temporary casings may remain in place if approved, and
- (3) Concrete placement may be paused near the top of pier elevations for anchor rod assembly installation and conduit placement or
- (4) If applicable, concrete placement may be stopped at bottom of grade beam or wing elevations for grade beam or wing construction.

If wet placement of concrete is anticipated or encountered, do not place Drilled Pier concrete until a concrete placement procedure is approved. If applicable, temporary casings and fluids may be removed when concrete placement is paused or stopped in accordance with the exceptions above provided holes are stable. Remove contaminated concrete from exposed Drilled Pier concrete after removing casings and fluids. If holes are unstable, do not remove temporary casings until a procedure for placing anchor rod assemblies and conduit or constructing grade beams or wings is approved.

Use collars to extend drilled piers above finished grade. Remove collars after Drilled Pier concrete sets and round top edges of piers.

If drilled piers are questionable, pile integrity testing (PIT) and further investigation may be required in accordance with Article 411-5 of the 2012 *Standard Specifications for Roads and Structures*. A drilled pier will be considered defective in accordance with Subarticle 411-5(D) of the 2012 *Standard Specifications for Roads and Structures* and drilled pier acceptance is based in part on the criteria in Article 411-6 except for the top of pier tolerances in Subarticle 411-6(C).

If a drilled pier is under further investigation, do not grout core holes, backfill around the pier or perform any work on the drilled pier until the Engineer accepts the pier. If the drilled pier is accepted, dewater and grout core holes and backfill around the pier with approved material to finished grade. If the Engineer determines a pier is unacceptable, remediation is required in accordance with Article 411-6 of the 2012 *Standard Specifications for Roads and Structures*. No extension of completion date or time will be allowed for remediation of unacceptable drilled piers or post repair testing.

Permanently embed a plate in or mark top of piers with the pier diameter and depth, size and number of vertical reinforcing bars and the minimum compressive strength of the concrete mix at 28 days.

(B) Footings, Pedestals, Grade Beams and Wings

Excavate as necessary for footings, grade beams and wings in accordance with the plans, accepted submittals and Section 410 of the 2012 *Standard Specifications for Roads and Structures*. If unstable, caving or sloughing materials are anticipated or encountered, shore foundation excavations as needed with an approved method. Notify the Engineer when foundation excavation is complete. Do not place concrete or reinforcing steel until excavation dimensions and foundation material are approved.

Construct cast-in-place reinforced concrete footings, pedestals, grade beams and wings with the dimensions shown in the plans and in accordance with Section 825 of the 2012 *Standard Specifications for Roads and Structures*. Use forms to construct portions of pedestals and grade beams protruding above finished grade. Provide a chamfer with a 3/4" horizontal width for pedestal and grade beam edges exposed above finished grade. Backfill and fill in accordance with Article 410-8 of the 2012 *Standard Specifications for Roads and Structures*. Proper compaction around footings and wings is critical for foundations to resist uplift and torsion forces. Place concrete against undisturbed soil and do not use forms for standard foundations for low level light standards.

(C) Anchor Rod Assemblies

Size anchor rods for design and the required projection above top of foundations. Determine required anchor rod projections from nut, washer and base plate thicknesses and the following:

- (1) Protrusion of 3 to 5 anchor rod threads above top nuts after tightening and
- (2) Distance of one nut thickness between top of foundations and bottom of leveling nuts.

Protect anchor rod threads from damage during storage and installation of anchor rod assemblies. Before placing anchor rods in foundations, turn nuts onto and off rods past leveling nut locations. Turn nuts with the effort of one workman using an ordinary wrench without a cheater bar. Report any thread damage to the Engineer that requires extra effort to turn nuts.

Arrange anchor rods symmetrically about center of base plate locations as shown in the plans. Set anchor rod elevations based on required projections above top of foundations. Securely brace and hold rods in the correct position, orientation and alignment with a steel template. Do not weld to reinforcing steel, temporary casings or anchor rods.

Install top and leveling (bottom) nuts, washers and the base plate for each anchor rod assembly in accordance with the following procedure:

- (1) Turn leveling nuts onto anchor rods to a distance of one nut thickness between the top of foundation and bottom of leveling nuts. Place washers over anchor rods on top of leveling nuts.
- (2) Determine if nuts are level using a flat rigid template on top of washers. If necessary, lower leveling nuts to level the template in all directions or if applicable, lower nuts to tilt the template so the metal pole or upright truss will lean as shown in the plans. If leveling nuts and washers are not in full contact with the template, replace washers with galvanized beveled washers.
- (3) Verify the distance between the foundation and leveling nuts is no more than one nut thickness.
- (4) Place base plate with metal pole or upright truss over anchor rods on top of washers. High mount luminaires may be attached before erecting metal poles but do not attach cables, mast arms or trusses to metal poles or upright trusses at this time.
- (5) Place washers over anchor rods on top of base plate. Lubricate top nut bearing surfaces and exposed anchor rod threads above washers with beeswax, paraffin or other approved lubricants.
- (6) Turn top nuts onto anchor rods. If nuts are not in full contact with washers or washers are not in full contact with the base plate, replace washers with galvanized beveled washers.
- (7) Tighten top nuts to snug-tight with the full effort of one workman using a 12" wrench. Do not tighten any nut all at once. Turn top nuts in increments. Follow a star pattern cycling through each nut at least twice.
- (8) Repeat (7) for leveling nuts.
- (9) Replace washers above and below the base plate with galvanized beveled washers if the slope of any base plate face exceeds 1:20 (5%), any washer is not in firm contact with the base plate or any nut is not in firm contact with a washer. If any washers are replaced, repeat (7) and (8).
- (10) With top and leveling nuts snug-tight, mark each top nut on a corner at the intersection of 2 flats and a corresponding reference mark on the base plate. Mark top nuts and base plate with ink or paint that is not water-soluble. Use the turn-

of-nut method for pretensioning. Do not pretension any nut all at once. Turn top nuts in increments for a total of one flat (1/6 revolution). Follow a star pattern cycling through each nut at least twice.

- (11) Ensure nuts, washers and base plate are in firm contact with each other for each anchor rod. Cables, mast arms and trusses may now be attached to metal poles and upright trusses.
- (12) Between 4 and 14 days after pretensioning top nuts and in the presence of the Engineer, check nuts with a torque wrench. Use a torque wrench with a calibration certificate less than a year old and provide a copy of this certificate to the Engineer. Completely erect mast arm poles and cantilever signs and attach any hardware before checking top nuts for these structures with a torque wrench.
- (13) If less than 600 ft-lb of torque is required to move any top nut, tighten nut to at least 600 ft-lb.
- (14) Do not grout under base plate.

OVERHEAD SIGN SUPPORTS

(9-1-11)

DB11 R012

Description

Design, fabricate, furnish and erect various types of overhead sign assemblies. Fabricate supporting structures using tubular members of either aluminum or steel. The types of overhead sign assemblies included in this specification are span structures, cantilever structures and sign structures attached to bridges.

Materials

Structural Steel	Section 1072
Overhead Sign Structures	Section 1096
Signing Materials	Section 1092
Organic Zinc Repair Paint	Article 1080-9
Reinforcing Steel	Section 1070
Direct Tension Indicators	Sections 440 and 1072

Construction Methods

A. General

Fabricate overhead sign assemblies in accordance with the details shown in the approved working drawings and the requirements of these specifications.

No welding, cutting or drilling will be permitted in the field, unless approved by the Engineer.

Drill bolt holes and slots to finished size. Holes may also be punched to finished size, provided the diameter of the punched holes is at least twice the thickness of the metal being punched. Flame cutting of bolt holes and slots is not permitted.

Erect sign panels in accordance with the requirements for Type A or B signs as indicated in the plans or Roadway Standard Drawings. Field drill two holes per connection in the Z bars for attaching signs to overhead structures. Provide two U-bolts at each U-bolt connection such as each truss chord to sign hanger and each truss chord to walkway support or light support. Provide two U-bolts at each U-bolt connection where ends of truss chords are supported. The minimum diameter of all U-bolts is ½ inch.

Use two coats of a zinc-rich paint to touch up minor scars on all galvanized materials.

For high strength bolted connections, use direct tension indicators. Galvanize bolts, nuts and washers in accordance with the 2012 *Standard Specifications for Roads and Structures*.

B. Shop Drawings

Design the overhead sign supports, including foundations, prior to fabrication. Submit design calculations and working drawings of the designs to the Engineer for review and acceptance.

Have a professional engineer registered in the State of North Carolina perform the computations and render a set of sealed, signed and dated drawings detailing the construction of each structure.

Submit to the Engineer for review and acceptance complete design and fabrication details for each overhead sign assembly, including foundations and brackets for supporting the signs and maintenance walkways, if applicable, electrical control boxes, and lighting luminaires. Base design upon the revised structure line drawings, wind load area and the wind speed shown in the plans, and in accordance with the *Standard Specifications for Structural Structures for Highway Signs, Luminaires and Traffic Signals*.

Submit thirteen (13) copies of completely detailed working drawings and one copy of the design calculations including all design assumptions for each overhead sign assembly to the Engineer for approval prior to fabrication. Working drawings shall include complete design and fabrication details (including foundations); provisions for attaching signs, maintenance walkways (when applicable), lighting luminaires to supporting structures, applicable material specifications, and any other information necessary for procuring and replacing any part of the complete overhead sign assembly.

Allow 15 days for initial working drawing review after the Engineer receives them. If revisions to working drawings are required, an additional 15 days shall be required for review and approval of the final working drawings.

Approval of working drawings by the Engineer shall not relieve the Design-Build Team of responsibility for the correctness of the drawings, or for the fit of all shop and field connections and anchors.

C. Design and Fabrication

The following criteria govern the design of overhead sign assemblies:

Design shall be in accordance with the *Standard Specifications for Structural Supports for Highway Signs, Luminaires and Traffic Signals, 4th Edition, 2001*, and the latest Interim Specifications.

Within this Specification, there are several design criteria that are owner specified. They include:

- The wind pressure map that is developed from the 3-second gust speeds, as provided in Article 3.8, shall be used.
- Overhead cantilever sign structures shall include galloping loads (exclude four-chord horizontal trusses), truck-induced gust loading and natural wind gust loading in the fatigue design, as provided for in Article 11.7.1, 11.7.4 and 11.7.3 respectively.
- The natural wind gust speed in North Carolina shall be assumed to be 11.6 mph for inland areas.
- The fatigue importance category used in the design, for each type of structure, as provided for in Article 11.6, Fatigue Importance Factors, shall be Category II unless otherwise shown on the plans.

The following Specification interpretations or criteria shall be used in the design of overhead sign assemblies:

- For design of supporting upright posts or columns, the effective length factor for columns “K”, as provided for in Appendix B, Section B.5, shall be taken as the following, unless otherwise approved by the Engineer:
 - Case 1 For a single upright post of cantilever or span type overhead sign structure, the effective column length factor, “K”, shall be taken as 2.0.
 - Case 2 For twin post truss-type upright post with the post connected to one chord of a horizontal truss, the effective column length factor for that column shall be taken as 2.0.

Case 3 For twin post truss-type upright post with the post connected to two truss chords of a horizontal tri-chord or box truss, the effective column length factor for that column shall be taken as 1.65

- For twin post truss-type upright post, the unbraced length shall be from the chord to post connection to the top of base plate.
- For twin post truss-type upright post, that is subject to axial compression, bending moment, shear, and torsion the post shall satisfy *Standard Specifications for Structural Supports for Highway Signs, Luminaries and Traffic Signals* Equations 5-17, 5-18 and 5-19. To reduce the effects of secondary bending, in lieu of Equation 5-18, the following equation may be used:

$$\frac{f_a}{F_a} + \frac{f_b}{\left(1 - \frac{0.6f_a}{F_e}\right)F_b} + \left(\frac{f_v}{F_v}\right)^2 \leq 1.0$$

Where f_a = Computed axial compression stress at base of post

- The base plate thickness for all uprights and poles shall be a minimum of 2" but not less than that determined by the following criteria and design.

Case 1 Circular or rectangular solid base plates with the upright pole welded to the top surface of base plate with full penetration butt weld, and where no stiffeners are provided. A base plate with a small center hole, which is less than 1/5 of the upright diameter, and located concentrically with the upright pole, may be considered as a solid base plate.

The magnitude of bending moment in the base plate, induced by the anchoring force of each anchor bolt shall be calculated as $M = (P \times D_1) / 2$.

Case 2 Circular or rectangular base plate with the upright pole socketed into and attached to the base plate with two lines of fillet weld, and where no stiffeners are provided, or any base plate with a center hole that is larger in diameter than 1/5 of the upright diameter

The magnitude of bending moment induced by the anchoring force of each anchor bolt shall be calculated as $M = P \times D_2$.

- M - bending moment at the critical section of the base plate induced by one anchor bolt
- P - anchoring force of each anchor bolt

- D_1 - horizontal distance between the center of the anchor bolt and the outer face of the upright, or the difference between the radius of the bolt circle and the outside radius of the upright
 - D_2 - horizontal distance between the face of the upright and the face of the anchor bolt nut
- The critical section shall be located at the face of the anchor bolt and perpendicular to the radius of the bolt circle. The overlapped part of two adjacent critical sections shall be considered ineffective.
- The thickness of Case 1 base plate shall not be less than that calculated based on formula for Case 2.
- Uprights, foundations, and trusses that support overhead signs shall be designed in accordance with the Overhead and Dynamic Message Sign Foundations Project Special Provision for the effects of torsion. Torsion shall be considered from dead load eccentricity of these attachments, as well as for attachments such as walkways, supporting brackets, lights, etc., that add to the torsion in the assembly. Truss vertical and horizontal truss diagonals in particular and any other assembly members shall be appropriately sized for these loads.
- Uprights, foundations, and trusses that support overhead mounted signs shall be designed for the proposed sign wind area and future wind areas. The design shall consider the effect of torsion induced by the eccentric force location of the center of wind force above (or below) the center of the supporting truss. Truss vertical and horizontal truss diagonals in particular and any other assembly members shall be appropriately sized for these loads.
- Span type overhead sign structures with monotube horizontal supports shall be designed to resist the following:
 - Galloping shall be checked by applying an equivalent static load of 21 psf shear pressure vertically to projected area of the signs that are mounted to horizontal monotube support structures as viewed in the normal elevation.
 - Natural wind gust shall be checked by applying an equivalent static pressure of 5.2 psf multiplied by the drag coefficient, which is the same value as that used for cantilever structures. The natural wind gust pressure range shall be applied in the horizontal direction to the exposed area of all support members, signs and attachments.

- Truck-induced gust shall be checked by applying the following static pressure range:
 - $P_{TG} = 7.5 C_d I_f$ (psf) Eq. 11-7
 - $P_{TG} = 10.2 C_d I_f$ (psf) Eq. 11-8
- The pressure range given by Eq. 11-7 shall be applied horizontally to the area of signs and horizontal members, while the values given by Eq. 11-8 shall be applied in the vertical direction to the area of the structure elements and projected area of the sign as viewed in the normal elevation. These pressures shall be applied along the entire span of the structure or along 24 feet of the span, whichever is smaller.
- Importance Factors for Vibration and Fatigue Design for Noncantilevered Monotube Sign Support Structures:
 - Galloping 0.72
 - Natural Wind Gust 0.85
 - Truck-Induced Gust 0.9

For non-cantilevered monotube sign support structures, the following table and figures are considered as an required addition to the *Standard Specifications for Structural Support for Highway Signs, Luminaires and Traffic Signals*, 4th Edition, 2001:

Construction	Detail	Stress Category	Application	Example
Mechanically Fastened Connections	25. Bolts in Tension	D	Beam column connection for monotube structures	16
Fillet Weld Connections	26. Fillet welded with one side normal to applied stress	E'	Beam column connection for monotube structures	17
Mechanically Fastened Connections	27. High strength bolts in tension	D	Monotube or truss-chord splice	17
Fillet Weld Connections	28. Fillet welded with one side normal to applied stress	E'	Monotube or truss-chord splice	17
Mechanically Fastened Connections	29. U-bolts tied to transverse truss column to keep chords in place	D	Horizontal truss connection with vertical truss	18
Mechanically Fastened Connections	30. Net section of full-tightened, high tension bolts in shear	B	Truss bolted joint	18

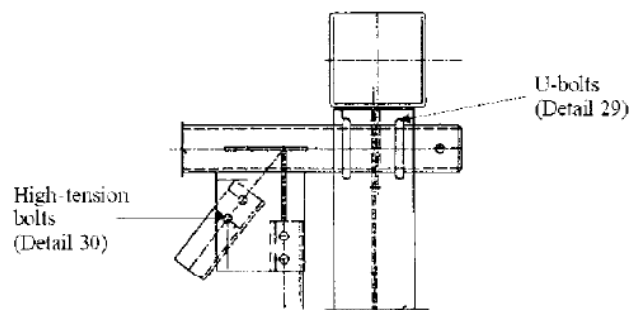
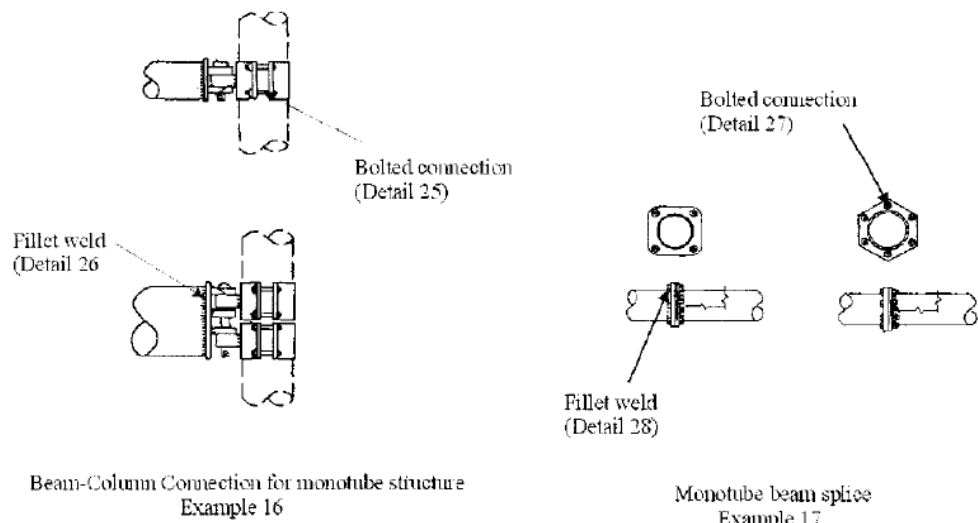
Add to the Specifications, Figure 11-1:

Beam-Column Connection for Truss Structure
Example 18

Fabricate all overhead sign assemblies, including but not limited to foundations, in accordance with the details shown on the approved shop drawings and with the requirements of these Specifications.

Fabricate the span and cantilever supporting structures using tubular members of either aluminum or steel, using only one type of material throughout the project. Sign support structures that are to be attached to bridges shall be fabricated using other structural shapes.

Horizontal components of the supporting structures for overhead signs may be of a truss design or a design using singular (monotube) horizontal members to support the sign panels.

Singular (monotube) horizontal members are not permitted for DMS. Truss or singular member centerline must coincide with the centerline of sign design area shown on the structure line drawing.

Provide permanent camber in addition to dead load camber in accordance with the *Standard Specifications for Structural Supports for Highway Signs, Luminaires, and Traffic Signals*. Indicate on the shop drawings the amount of camber provided and the method employed in the fabrication of the support to obtain the camber.

Use cantilever sign structures that meet the following design criteria:

a. Do not exceed an $L / 150$ vertical dead load deflection at the end of the arm due to distortions in the arm and vertical support, where L is the length of the arm from the center of the vertical support to the outer edge of the sign.

b. Do not exceed an $L / 40$ horizontal deflection at the end of the arm due to distortions in the arm and vertical support, as a result of design wind load.

Fabricate attachment assemblies for mounting signs in a manner that allows easy removal of sign panels for repair.

OVERHEAD AND DYNAMIC MESSAGE SIGN FOUNDATIONS

(9-1-11)

DB11 R013

Description

Sign foundations include foundations for overhead and dynamic message signs (DMS) supported by metal poles or upright trusses. Sign foundations consist of footings with pedestals or drilled piers with or without grade beams or wings, conduit and anchor rod assemblies. Construct sign foundations in accordance with the contract and accepted submittals. Define “cantilever sign” as an overhead cantilever sign support in accordance with Figure 1-1 of the *AASHTO Standard Specifications for Structural Supports for Highway Signs, Luminaires and Traffic Signals*.

Materials

Use sign foundation materials that meet the *Foundations and Anchor Rod Assemblies for Metal Poles* provision.

Assumed Subsurface Conditions

Assume the following soil parameters and groundwater elevation for sign foundations unless these subsurface conditions are not applicable to sign locations:

- (A) Unit weight = 120 lb/cf,
- (B) Friction angle = 30 degrees,
- (C) Cohesion = 0 lb/sf, and
- (D) Groundwater 7 ft below finished grade.

A subsurface investigation is required if the Engineer determines these assumed subsurface conditions do not apply to a sign location and the sign cannot be moved. Subsurface conditions

requiring a subsurface investigation include but are not limited to weathered or hard rock, boulders, very soft or loose soil, muck or shallow groundwater. No extension of completion date or time will be allowed for subsurface investigations.

Subsurface Investigations

Use a prequalified geotechnical consultant to perform one standard penetration test (SPT) boring in accordance with ASTM D1586 at each sign location requiring a subsurface investigation. Rough grade sign locations to within 2 feet of finished grade before beginning drilling. Drill borings to 2 drilled pier diameters below anticipated pier tip elevations or refusal, whichever is higher.

Use the computer software gINT version 8.0 or later manufactured by Bentley Systems, Inc. with the current NCDOT gINT library and data template to produce SPT boring logs. Provide boring logs sealed by a geologist or engineer licensed in the state of North Carolina.

Sign Foundation Designs

Design sign foundations for the appropriate wind zone and the clearances shown in the plans developed by the Design-Build Team and the slope of finished grade at each sign location. Use the assumed soil parameters and groundwater elevation above for sign foundation designs unless a subsurface investigation is performed or required by the Engineer. For sign locations requiring a subsurface investigation, design sign foundations for the subsurface conditions at each sign location. Design footings, pedestals, drilled piers, grade beams and wings in accordance with the 4th Edition of the *AASHTO Standard Specifications for Structural Supports for Highway Signs, Luminaires and Traffic Signals*. In some instances, conflicts with drainage structures may dictate sign foundation types.

Design footings in accordance with Section 4.4 of the *AASHTO Standard Specifications for Highway Bridges*. Do not use an allowable bearing pressure of more than 3,000 lb/sf for footings.

Design drilled piers for side resistance only in accordance with Section 4.6 of the *AASHTO Standard Specifications for Highway Bridges* except reduce ultimate side resistance by 25% for uplift. Use the computer software LPILE version 5.0 or later manufactured by Ensoft, Inc. to analyze drilled piers. Provide drilled pier designs with a horizontal deflection of less than 1" at top of piers. For cantilever signs with single drilled pier foundations supporting metal poles, use wings to resist torsion forces. Provide drilled pier designs with a factor of safety of at least 2.0 for torsion.

For drilled pier sign foundations supporting upright trusses, use dual drilled piers connected with a grade beam having a moment of inertia approximately equal to that of either pier. The Broms' method is acceptable to analyze drilled piers with grade beams instead of LPILE. Use a safety factor of at least 3.5 for the Broms' design method in accordance with C13.6.1.1 of the *AASHTO Standard Specifications for Structural Supports for Highway Signs, Luminaires and Traffic Signals*.

Submit boring logs, if any, working drawings and design calculations for acceptance in

accordance with Article 105-2 of the 2012 *Standard Specifications for Roads and Structures*. Submit working drawings showing plan views, required foundation dimensions and elevations and typical sections with reinforcement, conduit and anchor rod assembly details. Include all boring logs, design calculations and LPILE output for sign foundation design submittals. Have sign foundations designed, detailed and sealed by an engineer licensed in the state of North Carolina.

Construction Methods

Construct footings, pedestals, drilled piers, grade beams and wings and install anchor rod assemblies for sign foundations in accordance with the *Foundations and Anchor Rod Assemblies for Metal Poles* provision.

HIGH MOUNT FOUNDATIONS

(9-1-11)

DB11 R014

Description

High mount foundations for high mount standards consist of drilled piers or footings with pedestals, conduit and anchor rod assemblies. Construct high mount foundations in accordance with the contract and either *Roadway Standard Drawings* No. 1402.01 or the accepted submittals. Define “high mount standard foundation” as a drilled pier including the conduit and anchor rod assembly that meets Standard Drawing No. 1402.01.

Materials

Use high mount foundation materials that meet the *Foundations and Anchor Rod Assemblies for Metal Poles* provision.

High Mount Standard Foundations

Construct high mount standard foundations for the appropriate wind zone and high mount heights shown in the accepted plans developed by the Design-Build Team unless the following assumed site conditions are not applicable to high mount locations:

- (A) Soil with unit weight (γ) \cong 120 lb/cf and friction angle (ϕ) \cong 30° ,
- (B) Groundwater at least 7 ft below finished grade, and
- (C) Slope of finished grade 6:1 (H:V) or flatter.

A subsurface investigation and high mount foundation design are required if the Engineer determines these assumed site conditions do not apply to a high mount location and the high mount cannot be moved. Subsurface conditions requiring a high mount foundation design include but are not limited to weathered or hard rock, boulders, very soft or loose soil, muck or shallow groundwater. No extension of completion date or time will be allowed for subsurface investigations or high mount foundation designs.

Subsurface Investigations

Use a prequalified geotechnical consultant to perform one standard penetration test (SPT) boring in accordance with ASTM D1586 at each high mount location requiring a subsurface investigation. Rough grade high mount locations to within 2 ft of finished grade before beginning drilling. Drill borings to 2 drilled pier diameters below anticipated pier tip elevations or refusal, whichever is higher.

Use the computer software gINT version 8.0 or later manufactured by Bentley Systems, Inc. with the current NCDOT gINT library and data template to produce SPT boring logs. Provide boring logs sealed by a geologist or engineer licensed in the state of North Carolina.

High Mount Foundation Designs

Design high mount foundations for the wind zone and high mount heights shown in the accepted plans developed by the Design-Build Team and the slope of finished grade and subsurface conditions at each high mount location. Design drilled piers, footings and pedestals in accordance with the 4th Edition of the *AASHTO Standard Specifications for Structural Supports for Highway Signs, Luminaires and Traffic Signals*.

Design drilled piers for side resistance only in accordance with Section 4.6 of the *AASHTO Standard Specifications for Highway Bridges*. Use the computer software LPILE version 5.0 or later manufactured by Ensoft, Inc. to analyze drilled piers. Provide drilled pier designs with a horizontal deflection of less than 0.5" at top of piers.

Design footings in accordance with Section 4.4 of the *AASHTO Standard Specifications for Highway Bridges*. Do not use an allowable bearing pressure of more than 3,000 lb/sf for footings.

Submit boring logs, working drawings and design calculations for acceptance in accordance with Article 105-2 of the 2012 *Standard Specifications for Roads and Structures*. Submit working drawings showing plan views, required foundation dimensions and elevations and typical sections with reinforcement, conduit and anchor rod assembly details. Include all boring logs, design calculations and LPILE output for high mount foundation design submittals. Have high mount foundations designed, detailed and sealed by an engineer licensed in the state of North Carolina.

Construction Methods

Grade a 3 ft diameter level work area around high mount locations with cut and fill slopes as shown on Standard Drawing No. 1402.01. Construct drilled piers, footings and pedestals and install anchor rod assemblies for high mount foundations in accordance with the *Foundations and Anchor Rod Assemblies for Metal Poles* provision.

REPAIR OF BRIDGE DECKS AND APPROACH PAVEMENT WITH LATEX MODIFIED CONCRETE

Description

This work consists of repairing existing bridge decks and approach pavement by removing existing asphalt overlay and loose, deteriorated or contaminated concrete and resurfacing with latex modified concrete overlayment course together with other work necessary to restore structural integrity to the deck in accordance with this provision, applicable parts of the 2012 *Standard Specifications for Roads and Structures*, and the dimensions, lines and grades shown on the plans or established by the Engineer.

Equipment

Use the following Surface Preparation Equipment:

- Sawing equipment capable of sawing concrete to the specified depth.
- Scarifying equipment that is a power-operated, mechanical scarifier or grinder capable of removing at least 1/4 inch (6 mm) for each pass.
- Sandblasting equipment capable of removing rust scale from reinforcing steel, or removing small chips of concrete partially loosened by the scarifying or chipping operation, and of removing rehydrated dust left from scarification.
- Power driven hand tools for removal of unsound concrete are required that meet the following requirements:
 - Pneumatic hammers weighing a nominal 35 lb (16 kg) or less.
 - Pneumatic hammer chisel-type bits that do not exceed the diameter of the shaft in width.
 - Hand tools such as hammers and chisels for removal of final particles of unsound concrete.
 - Vibratory screed for overlays, except as noted herein.

Construction Methods

Remove all existing asphalt overlays and all loose, disintegrated, unsound or contaminated concrete from the bridge deck and approach pavement in accordance with the following surface preparation classifications:

- Class IA Surface Preparation: Scarify and remove portland cement concrete from the concrete approach pavement to the depth shown on the plans to permit the construction of a 1/4 inch (32 mm) minimum depth overlay on the approach pavement to the limits shown on the plans. Transversely saw the existing concrete pavement to create a square construction joint for the overlay. Remove concrete in front of the sawed joint with power driven hand tools. Dispose of removed concrete and thoroughly clean the exposed scarified pavement surface.
- Class IB Surface Preparation: Scarify, or use other acceptable means, to remove all asphalt overlay from the existing bridge deck and, if applicable, the concrete approach

pavement. Limits for this removal are the same as for Class I and, when applicable, Class IA Surface Preparation. Perform this work as a separate operation prior to the Class I or IA Surface Preparation and make sure the concrete surface is not removed.

- Class I Surface Preparation: Scarify and remove the entire concrete surface of the deck to a uniform depth of 1/2 inch (13 mm), remove and dispose concrete, and thoroughly clean the scarified surface. Perform Class I Surface Preparation before Class II or Class III. In areas where reinforcing steel is located in the 1/2 inch (13 mm) depth to be scarified, use another method with the Engineer's approval.
- Class II Surface Preparation (Partial Depth): Remove by chipping with hand tools all loose, unsound and contaminated deck concrete and in areas where reinforcing steel is exposed, by scarifying to an average depth of approximately one-half the deck thickness, but no less than 3/4 inch (19 mm) below the top mat of steel. Dispose of the removed concrete, clean, repair or replace rusted or loose reinforcing steel, and thoroughly clean the newly exposed surface.

When chipping, be careful not to cut, stretch, or damage any exposed reinforcing steel.

In overhangs, removing concrete areas of less than 0.60 ft²/ft (0.2 m²/m) length of bridge without overhang support is permitted unless the Engineer directs otherwise. For concrete areas greater than 0.60 ft²/ft (0.2 m²/m) length of bridge, approval of the overhang support is required.

Refill areas where concrete was removed with Class AA concrete up to the bottom of the proposed concrete overlay in accordance with Section 420 of the 2012 *Standard Specifications for Roads and Structures*. Any of the methods for curing Class AA concrete as stated in the 2012 *Standard Specifications for Roads and Structures* are permitted except the membrane curing compound method.

Provide a raked finish to the surface of the Class AA concrete. Place the overlay course only after the Class AA concrete has attained 2500 psi (17.2 MPa) as measured by an approved, non-destructive test method.

Refilling the areas from which concrete has been removed with latex modified concrete during the Class I repair is permitted if any of the following conditions are met:

- The reinforcing steel cover is 1½ inches (38 mm) or less.
 - The area being repaired is less than 1 yd² (1 m²).
 - The Engineer directs the fill.
- Class III Surface Preparation (Full Depth): Remove full depth all loose, unsound and contaminated deck concrete. Thoroughly clean the routed out area and dispose of concrete removed. Clean, repair, or replace reinforcing bars and fill the areas from which unsound concrete has been removed with Class AA concrete up to the bottom of the proposed concrete overlay.

Clean or replace reinforcing bars and place Class AA concrete in accordance with the methods described under Class II Surface Preparation.

Provide a raked finish to the surface of the Class AA concrete. Place the overlay course only after the Class AA concrete has attained 2500 psi (17.2 MPa) as measured by an approved non-destructive test method.

For areas of less than 3 ft², suspending forms from existing reinforcing steel using wire ties is permitted. For larger areas, support forms by blocking from the beam flanges.

Submit for approval detailed plans for Class III Surface Preparation. Detail how waste and debris is kept from falling below. When Class III repairs adjacent to the rail are necessary, support the rail in a manner approved by the Engineer.

General

After scarification, the Engineer locates and marks structural cracks. Remove all concrete within 2 inches (50 mm) each side of the crack by chipping to a minimum depth of 3/4 inch (19 mm). When reinforcing steel is exposed, chip to a minimum depth of 3/4 inch (19 mm) below the top mat of steel. Remove, chip, and dispose of the concrete, clean, repair, or replace reinforcing bars, and place Class AA concrete in accordance with the methods described under Class II or III Surface Preparation.

When concrete is removed under Class II or III Surface Preparation, provide 90° corners and vertical sides.

The Engineer determines the areas where concrete is to be removed under Class II or Class III Surface Preparation and inspects for delaminations by sounding with a chain drag.

Thoroughly clean exposed reinforcing steel by sandblasting. Remove bar sections that have lost 25% or more of their original section dimension and weld new, same-size bars in their place. Maintain 1½ inches (38 mm) cover of Class AA concrete over the reinforcing steel.

Provide a minimum overlay thickness of 1¼ inches (32 mm) and a final surface that is approximately ¾ inch (19 mm) higher than the original surface. Prior to placing the overlay, attach a 1¼ inch (32 mm) filler block to the bottom of the screed and pass it over the area to be repaired to check the thickness. Remove all concrete that the block does not clear.

Keep areas where unsound concrete has been removed free of slurry produced from wet sawing or scarifying by planning the work so that this slurry drains away from the completed area of preparation. Remove all slurry from prepared areas before placing any overlay. Sandblast the edge of previously placed lanes of overlayment. If necessary, use detergent followed by sand and air blasting to remove rust, oil, or other foreign materials detrimental to achieving bond.

EMPLOYMENT

(9-1-11)

DB1 G184

Revise the 2012 *Standard Specifications for Roads and Structures* as follows:

Page 1-20, Subarticle 102-15(O), delete and replace with the following:

(O) Failure to restrict a former Department employee as prohibited by Article 108-5.

Page 1-65, Article 108-5 CHARACTER OF WORKMEN, METHODS, AND EQUIPMENT, delete the first sentence of the second paragraph and delete the first word of the second sentence of the second paragraph.

GENERAL

The State will not be bound by oral explanations or instructions given at any time during the bidding process or after award. Only information that is received in response to this RFP will be evaluated; reference to information previously submitted will not suffice as a response to this solicitation.

NO CONTACT CLAUSE

To ensure that information is distributed equitably to all short-listed Design-Build Teams, all questions and requests for information shall be directed to the State Contract Officer through the Design-Build e-mail address. This precludes any Design-Build Team Member, or representative, from contacting representatives of the Department, other State Agencies or Federal Agencies either by phone, e-mail or in person concerning the Design-Build Project.

USE OF TERMS

Throughout this RFP and all manuals, documents and standards referred to in the RFP the terms Contractor, Bidder, Design-Builder, Design-Build Team, Team, Firm, Company, and Proposer are synonymous.

Throughout this RFP and all manuals, documents and standards referred to in the RFP, the terms NCDOT, Department, Engineer, and State are synonymous.

Throughout this RFP and all documents referred to in the RFP, references to the Technical Proposal include all Technical Proposal supplemental information that may be submitted in response to a Best and Final Offer RFP.

DESIGN REFERENCES

Design references developed and published by NCDOT and those developed and published by other agencies and adopted for use by NCDOT which are to be used in the design of this project may be obtained by contacting Contract Standards and Development within the Technical Services Division. Standard prices for materials, which the Department normally sells for a fee, will be in effect. The Design-Build Team shall be responsible for designing in accordance with the applicable documents and current revisions and supplements thereto.

REVIEW OF SUBMITTALS

Major design milestones and required design submittals shall be identified as activities on a CPM, bar chart, or other scheduling tool. This schedule shall be submitted to the Transportation Program Management Director and Resident Engineer concurrently with the first design submittal, or within 30 days of the contract award, whichever is earlier. The schedule shall be revised and resubmitted as design milestones change or as directed by the Transportation Program Management Director. Submittals will be reviewed within 10 working days (15 days for temporary structures, overhead sign assemblies, MSE walls, FEMA compliance documents, curved steel girder working drawings and temporary shoring) from the date of receipt by NCDOT unless otherwise stipulated in the scope of work. All submittals shall be prepared and

submitted in accordance with the “*Design-Build Submittal Guidelines*”, which by reference are incorporated and made a part of this contract. All submittals shall be made simultaneously to the Transportation Program Management Director and the Resident Engineer. The Department will not accept subsequent submittals until prior submittal reviews have been completed for that item. The Design-Build Team shall inform the Transportation Program Management Director in writing of any proposed changes to the NCDOT preliminary designs, Technical Proposal and / or previously reviewed submittals and obtain approval prior to incorporation. The Design-Build Team shall prioritize submittals in the event that multiple submittals are made based on the current schedule. All submittals shall include pertinent Special Provisions. No work shall be performed prior to Department review of the design submittals.

OVERVIEW

The Design-Build Project, R-4902, widens I-485 from west of I-77 to east of US 521 (Johnston Rd.) south of Charlotte, in Mecklenburg County. The total project length is approximately 6.8 miles. The proposed improvements consist of adding an additional inside lane in each direction, thus making the facility a six-lane divided interstate. The project also includes a new flyover from US 521 northbound to I-485 westbound, construction of an auxiliary lane to the outside shoulder of westbound I-485 from US 521 to NC 51 (Pineville-Matthews Road), and the widening of twelve existing bridges on I-485.

Project services shall include, but are not limited to:

- **Design Services** – completion of construction plans, including Record Drawings
- **Construction Services** – necessary to build and ensure workmanship of the designed facility
- **Permit Preparation / Application** - development of all documents for required permits
- **Right of Way** – acquisition of right of way necessary to construct project

The R-4902 Categorical Exclusion (CE) was approved on June 29, 2011.

Construction Engineering Inspection will be provided by the NCDOT Division personnel.

GENERAL SCOPE

The scope of work for this project includes design, construction and management of the project. The design work includes all aspects to construct approximately 6.8 miles of a six-lane divided facility. The designs shall meet all appropriate latest versions of *AASHTO Policy on Geometric Design of Highways and Streets*, *AASHTO LRFD Bridge Design Specifications*, *Manual of Uniform Traffic Control Devices*, and all NCDOT design policies that are current as of the Technical and Price Proposal submission date or the Best and Final Offer submission date.

Construction shall include, but not be limited to, all necessary clearing, grading, roadway, drainage, structures, utility coordination and relocation, and erosion and sediment control work items for the proposed six-lane facility. Construction engineering and management shall be the responsibility of the Design-Build Team. Construction shall comply with 2012 *NCDOT Standard Specifications for Roads and Structures* and any special provisions.

Areas of work required for this project shall include, but are not limited to the following items:

- Roadway Design
- Structure Design
- Hydraulic Design
- Permit Application
- Railroad Coordination
- Foundation Design for Structures and Roadway
- Erosion and Sediment Control Design and Implementation
- R/W Utilities, Conflicts and / or Construction
- Traffic Control Design
- Pavement Marking Design
- Sign Design
- ITS Design
- Traffic Management and Signal System Design
- Construction
- Project Management
- Design and Construction Management
- Construction Surveying
- Location and Surveys
- Lighting (Construction Only)
- Right of Way Acquisition, as needed
- Public Information

All designs shall be in Microstation format using Geopak software (current version used by the Department).

DESIGN AND CONSTRUCTION PERFORMED BY DESIGN-BUILD TEAM

The design work consists of the preparation of all construction documents for constructing approximately 6.8 miles of a six-lane divided facility as outlined in the Scope of Work section of this RFP. The Design-Build Team shall prepare final designs, construction drawings and special provisions.

The Design-Build Team shall acknowledge that project documents furnished by the Department are preliminary and provided solely to assist the Design-Build Team in the development of the project design. The Design-Build Team shall be fully and totally responsible for the accuracy and completeness of all work performed under this contract and shall save the State harmless and shall be fully liable for any additional costs and all claims against the State which may arise due to errors, omissions and negligence of the Design-Build Team in performing the work required by this contract.

There shall be no assignment, subletting or transfer of the interest of the Design-Build Team in any of the work covered by the Contract without the written consent of the State, except that the Design-Build Team may, with prior written notification of such action to the State, sublet property searches and related services without further approval of the State.

The Design-Build Team shall certify all plans, specifications, estimates and engineering data furnished by the Team.

All work by the Design-Build Team shall be performed in a manner satisfactory to the State and in accordance with the established customs, practices, and procedures of the North Carolina Department of Transportation, and in conformity with the standards adopted by the American Association of State Highway Transportation Officials, and approved by the U.S. Secretary of Transportation as provided in Title 23, U.S. Code, Section 109 (b). The decision of the Engineer / State / Department shall control in all questions regarding location, type of design, dimension of design, and similar questions.

Alternate designs, details, or construction practices (such as those employed by other states, but not standard practice in NC) are subject to Department review and will be evaluated on a case by case basis.

The Design-Build Team shall not change team members, subconsultants or subcontractors identified in the Statement of Qualifications (SOQ) or Technical Proposal without written consent of the Engineer or the State Contract Officer. In addition, subconsultants and subcontractors not identified in the SOQ or Technical Proposal shall not perform any work without written consent by the Engineer. Individual offices of the Design-Build Team not identified in the Statement of Qualifications or the Technical Proposal submitted shall not perform any work without written consent by the Engineer. Failure to comply with this requirement may be justification for removing the Team from further consideration for this project and disqualification from submitting on future Design-Build Projects.

All firms shall be prequalified by the Department for the work they are to perform. Joint Ventures, LLCs or any legal structure that are different than the existing prequalification status must be prequalified prior to the Technical and Price Proposal submittal deadline. Subcontractors need only be prequalified prior to performing the work. Design firms should be prequalified prior to the Technical and Price Proposal submittal deadline. If not prequalified at the time of the Technical and Price Proposal submittal deadline, the prime contractor shall be solely responsible for either (1) ensuring that the design firm is prequalified prior to its first design submittal or (2) replacing that firm with a prequalified firm. Design firms and Natural Systems firms are prequalified by the particular office performing the work. If the work is to be performed by an office other than the one that is prequalified, that office shall be prequalified prior to any design submittals.

ETHICS POLICY

Employees employed by the Design-Build Team or employees employed by any subconsultant for the Design-Build Team to provide services for this project shall comply with the Department's ethics policy. Failure to comply with the ethics policy will result in the employee's removal from the project and may result in removal of the Company from the Department's appropriate prequalified list.

APPROVAL OF PERSONNEL

The Department will have the right to approve or reject any personnel, assigned to a project by the Design-Build Team.

In the event of engagement of a former employee of the Department, the Design-Build Team or their subcontractors shall restrict such person or persons from working on any of the Design-Build Team's contracted projects in which the person or persons were "formerly involved" while employed by the State. The restriction period shall be for the duration of the contracted project with which the person was involved. *Former Involvement* shall be defined as active participation in any of the following activities:

- Drafting the contract
- Defining the contract scope of the contract
- Design-Build Team selection
- Negotiation of the contract cost (including calculating manhours or fees); and
- Contract administration

An exception to these terms may be granted when recommended by the Secretary and approved by the Board of Transportation.

Failure to comply with the terms stated above in this section shall be grounds for termination of this contract and / or not being considered for selection of work on future contracts for a period of one year.

SUBMITTAL OF TECHNICAL AND PRICE PROPOSALS

Technical and / or Price Proposals that do not adhere to all the requirements noted below may be considered non-responsive and may result in the Department not considering the Design-Build Team for award of the contract or reading their Price Proposal publicly.

GENERAL

Technical and Price Proposals will be accepted until **4:00 p.m. Local Time on Tuesday, February 28, 2012**, at the office of the State Contract Officer:

Mr. Randy A. Garris, PE
Contract Standards and Development
1020 Birch Ridge Drive
Century Center Complex - Building B
Raleigh, NC 27610

No Proposals will be accepted after the time specified.

Proposals shall be submitted in 2 separate, sealed parcels containing the Technical Proposal in one and the Price Proposal in the other parcel.

TECHNICAL PROPOSAL

Technical Proposals shall be submitted in a sealed package. The outer wrapping shall clearly indicate the following information:

Technical Proposal
Submitted By: (Design-Build Team's Name)
Design-Build Team Address
Contract Number C 202831
TIP Number R-4902
Mecklenburg County
I-485 from west of I-77 to east of US 521 (Johnston Road) south of Charlotte

If delivered by mail, the sealed envelope shall be placed in another sealed envelope and the outer envelope addressed to the Contract Officer as stated in the Request for Proposals. The outer envelope shall also bear the statement "Technical Proposal for the Design-Build of State Highway Contract No. C 202831".

Technical Proposal Requirements

12 Copies
8 ½ inch by 11 inch pages
No fold-out sheets allowed
Printed on one side only
Double-spaced
Font size 12
Minimal font size 10 is permissible within embedded tables, charts, or graphics. No more than 40 pages, excluding the introductory letter to Mr. Randy Garris, P.E. (two-page maximum length) and the 11 inch by 17 inch appropriate plan sheets
24 x 36 inch fold out sheets will only be allowed to present interchange plans

Key Project Team members, identified in the Statement of Qualifications, shall not be modified in the Technical Proposal without written approval of the Department. Any such request should be sent to the attention of Mr. Randy Garris, PE, at the address below:

NCDOT- Contract Standards and Development
Century Center Complex - Building B
1020 Birch Ridge Drive
Raleigh, NC 27610

PRICE PROPOSAL

Price Proposals shall be submitted in a sealed package. The outer wrapping will clearly indicate the following information:

Price Proposal
Submitted by (Design-Build Team's Name)
Design-Build Team Address
Contract Number C 202831
TIP Number R-4902
Mecklenburg County
I-485 from west of I-77 to east of US 521 (Johnston Road) south of Charlotte

The Price Proposal shall be submitted by returning the Request for Proposals with the item sheets completed, and all required signatures and bonds. Failure to execute the required documents may render the proposal non-responsive.

If delivered by mail, the sealed envelope shall be placed in another sealed envelope and the outer envelope addressed to the Contract Officer as stated in the Request for Proposals. The outer envelope shall also bear the statement "Price Proposal for the Design-Build of State Highway Contract No. C 202831".

EVALUATIONS

Decisions based on cost alone will not establish the design standards for the project. Technical Proposals shall address the technical elements of the design and construction of the project. The Technical Review Committee will consider the understanding of the project, the anticipated problems and the solutions to those problems, in addition to other evaluation criteria identified herein.

The Design-Build Team's Technical Proposal shall be developed using narratives, tables, charts, plots, drawings and sketches as appropriate. The purpose of the Technical Proposal is to document the firm's understanding of the project, demonstrate the Team's capabilities to complete the project, document their selection of appropriate design criteria, and state their approach and schedule for completing all design and construction activities.

The review of design plans by the Department is not intended to reflect a reviewer's personal preferences, but rather to ensure that all contract requirements are met, sound engineering judgment is exercised by the Design-Build Team, and that the Design-Build Team adheres to all referenced documents, including but not limited to, design standards, codes, memos and manuals. As such, the award of the Design-Build contract does not in any way imply that the NCDOT accepts the details of the Technical Proposal submitted by the Design-Build Team.

The Technical Proposal will be evaluated in each of the following major categories:

	EVALUATION FACTORS	POINTS
1.	Management	10
2.	Responsiveness to Request for Proposal	25
3.	Long Term Maintenance	4
4.	Schedule and Milestones	33
5.	Innovation	5
6.	Maintenance of Traffic and Safety Plan	20
7.	Oral Interview	3

TECHNICAL PROPOSAL EVALUATION CRITERIA

1. Management – 10 points

Design-Build Team Management

- Describe the Design-Build Team's concept of design management. The proposal shall identify key positions and subordinate organizational units.
- Describe the plan for the coordination of civil / structural, utilities, traffic maintenance, constructability and environmental responsibility.
- Provide a narrative description of the proposed location of the design office(s) and their respective responsibilities.
- Describe how the designs developed by different firms and offices will be integrated.
- Describe how design personnel will interface with the construction personnel.
- Describe the overall strengths of the Design Team and their ability to fulfill the design requirements of this project.
- List projects, including description and similarity to the subject project that the Team's designer(s) developed Traffic Management Plans and Signing Plans.

Quality Management

- Describe how the Design-Build Team will comply with the quality control requirements for both design and construction. Specifically, include a narrative describing the Design-Build Team's understanding of the Department's construction quality control philosophy for this project and how the Design-Build Team will implement it.
- The Design-Build Team should detail the number of inspectors they expect the Department to furnish, during various phases, to allow satisfactory progress of project construction.
- Describe any significant quality control issues experienced on NCDOT projects in the last ten years and how those issues will be addressed for this project.
- The narrative shall include both design and construction activities.

Construction Management

- Describe the Design-Build Team's concept of the project construction management organization and how it interrelates with the other elements of the Design-Build Team's organization for the project.
- Provide a brief narrative description of the Design-Build Team's proposed plan for performing construction on the project. This description shall include at least the following:
 - A construction organization chart for the project, showing the relationships between functions shown on the chart and the functional relationships with subcontractors.
 - The chart shall indicate how the Design-Build Team intends to divide the project into work segments to enable optimum construction performance.
 - Descriptions of those categories of work that the Design-Build Team anticipates will be performed by the Design-Build Team's own direct labor force and those categories that will be performed by subcontractors.
 - The Design-Build Team's plans and procedures to insure timely deliveries of materials to achieve the project schedule.
 - Describe the overall strengths of the construction team and their ability to fulfill the construction and construction management requirements of this project.
 - Describe the Design-Build Team's approach to site access and material staging.

2. Responsiveness to RFP – 25 points

Natural Environmental Responsibility

- Describe the Design-Build Team's approach to addressing environmental concerns within the project boundaries.
- Identify efforts to minimize impacts on wetlands, streams, riparian buffers and other environmentally sensitive areas.
- Identify innovative approaches to minimize any impacts in environmentally sensitive areas. Describe any temporary impacts and associated minimization approaches.
- Describe the Design-Build Team's understanding of the overall approach to permitting and the Team's comfort level with obtaining the required permits within the allowed timeframe.
- Describe any Notice of Violations (NOVs) the Design-Build Team members have received from regulatory agencies in North Carolina or any other State within the last five years and the disposition of each listed NOV.
- Describe the Design-Build Teams approach to Sedimentation and Erosion Control for the project.
- Provide a narrative overview of the Design-Build Team's Vegetation Management Plan.

Design Features

- Show plan view of design concepts with key elements noted.
- Identify preliminary horizontal and vertical alignments of all roadway elements.
- Show typical sections for the mainline of the project specifying the pavement alternate chosen.
- Identify proposed deviations to the preliminary design provided by the Department.
- Identify the appropriate design criteria for each feature, if not provided.
- Identify any deviations, including proposed design exceptions, from the established design criteria that will be utilized. Explain why the deviation is necessary.
- Identify drainage modifications and designs to be implemented.
- Discuss proposed superelevation, grades, etc. and how they will minimize hydroplaning concerns for this project and the future median widening of I-485 to an eight-lane facility.
- Identify all bridge types to be constructed, including any special design features or construction techniques needed.
- Describe any geotechnical investigations to be performed by the Design-Build Team and note any deviations to the NCDOT requirements for subsurface investigations noted in the Geotechnical Scope of Work.
- Identify any special aesthetics considerations that will be part of the design.
- Describe how utility conflicts will be addressed and any special utility design considerations. Describe how the Design-Build Team's design and construction methods minimize the Department's utility relocation costs.
- Identify any right of way needed and how the design will affect the Department's right of way costs.
- Identify types of any retaining walls and / or sound barrier walls if applicable.
- Identify the mainline pavement design chosen. The pavement type chosen for the mainline will not be a part of the Technical Proposal evaluation and the selection thereof will not impact the technical scores, although an alternate pavement design as approved as an ATC may be considered in the evaluation.

3. Long Term Maintenance – 4 points

- Describe any special materials, not referenced elsewhere in the contract, incorporated into the project that would result in long term reduction in maintenance.
- Describe any special designs or construction methods that would reduce future maintenance costs to the Department.
- Estimate a minimum ten-year cost saving resulting from incorporation of these special materials, design, or construction methods into the project.

4. Schedule and Milestones – 33 points

- Provide a detailed schedule for the project including both design and construction activities. The schedule shall show the sequence and continuity of operations, as well as the month of delivery of usable segments of the project.

- The schedule shall also include the Design-Build Team's final completion date and, if proposed, their substantial completion date. **These dates shall be clearly indicated on the Project Schedule and labeled "Final Completion Date" and "Substantial Completion Date"**.

5. Innovation – 5 points

- Identify any aspects of the design or construction elements that the Design-Build Team considers innovative. Include a description of alternatives that were considered whether implemented or not.

6. Maintenance of Traffic and Safety Plan – 20 points

Maintenance of Traffic

- Describe any traffic control requirements that will be used for each construction phase.
- Describe how traffic will be maintained as appropriate and describe the Design-Build Team's understanding of any time restrictions noted in the RFP.
- Indicate the type of positive median cross-over protection proposed for the entire I-485 project limits and replacement / resetting requirements.
- Indicate how hauling will be conducted including, but not limited to, hauling of materials to and from the site and hauling materials within the NCDOT right of way.
- Identify a Traffic Control Supervisor and their qualifications.
- If a temporary portable barrier system will be utilized, provide the type and why it is needed.
- If temporary shoring will be required, provide the type and why it is required.
- Identify all proposed offsite detours including justification and duration for each. The duration of all offsite detours shall be provided in calendar days.
- Identify the need for a Speeding Penalty Ordinance.
- Address where and how law enforcement officers will be used.

Safety Plan

- Describe the safety considerations specific to the project.
- Discuss the Design-Build Team's overall approach to safety.
- Describe any proposed improvements that will be made prior to or during construction that will enhance the safety of the work force and / or travelling public both during and after the construction of the project.

7. Oral Interview – 3 points

- The Design-Build Team's Project Management Team shall present a brief introduction of the project team and design / construction approach.
- Introductory comments shall be held to no more than 30 minutes.

- The Department will use this interview to ask specific questions about the Team's Technical Proposal, background, philosophies, and approach to the project.
- Presentation, questions, and answers shall not exceed 90 minutes. No more than 10 people from the Design-Build Team may attend.

The Department will use the information presented in the oral interview to assist in the evaluation of the Technical Proposal.

Additional Warranty and / or Guarantee

- **The Extra Credit for this project shall be a Maximum of 5 Points.**

A twelve-month guarantee as outlined in the *Twelve-Month Guarantee* Project Special Provision is required for this project. However, the Design-Build Team may provide additional warranties and / or guarantees at their discretion. The Design-Build Team may be awarded additional points as "extra credit" to be added to the Technical Score.

The Design-Build Team may provide warranties and / or guarantees for major components of the project. Examples of major components are pavements, bridge components, and sign structures. If additional warranties and / or guarantees are offered, the Design-Build Team shall indicate in the Technical Proposal the general terms of the warranties and / or guarantees, a list of the items covered, performance parameters, notification and response parameters for corrective action, and evaluation periods. The Department will be responsible for annual inspections of the components covered by all warranties and / or guarantees offered by the Design-Build Team that extend beyond the required Twelve-Month Guarantee. The warranties and / or guarantees shall also define how disputes will be handled. Prior to the first partial payment, the Design-Build Team shall submit a document that provides additional warranty / guarantee specifics in sufficient detail that allows the document to be made a part of the contract through supplemental agreement.

No direct payment will be made for warranties and / or guarantees. Payment will be considered incidental to the lump sum price for the contract.

SELECTION PROCEDURE

There will be a Technical Review Committee (TRC) composed of five or more senior personnel from involved engineering groups that will evaluate the Technical Proposal on the basis of the criteria provided in the Request for Proposals.

The selection of a Design-Build Team will involve both technical quality and price. The Technical Proposals will be presented to the TRC for evaluation. The TRC shall first determine whether the proposals are responsive to the requirements of the Request for Proposals. The Department reserves the right to ask for clarification on any item in the Technical Proposal. A written response to this request for clarification shall be provided to the Department prior to the opening of the Price Proposals. The contents of the written response may affect the Technical Review Committee's determination of the Technical Proposal's responsiveness and/or the overall evaluation of the Technical Proposal. If any commitments or clarifications provided in

the written response conflict with the contents of the Technical Proposal, the contents of the written response will govern and be incorporated into the contract.

Each responsive Technical Proposal shall be evaluated based on the rating criteria provided in the Request for Proposals. The TRC will submit an overall consensus Technical Proposal score for each Design-Build Team to the State Contract Officer.

Quality Credit Evaluation Factors for Technical Proposals

Management	10
Responsiveness to Request for Proposal	25
Long Term Maintenance	4
Schedule and Milestones	33
Innovation	5
Maintenance of Traffic and Safety Plan	20
Oral Interview	3
Maximum Score	100

The State Contract Officer will use a table based on the maximum quality credit percentage to assign a Quality Credit Percentage to each proposal based on the proposal's overall Technical Score. The maximum quality credit percentage for this project will be **20%**. The Technical Review Committee may elect to assign point values to the nearest one-half of a point (e.g. 90.5). In this event, the Quality Credit Percentage will be determined by linearly interpolating within the table entitled "Quality Credit Percentage for Technical Proposals".

Quality Credit Percentage for Technical Proposals

Technical Score	Quality Credit (%)	Technical Score	Quality Credit (%)
100	20.00	84	9.33
99	19.33	83	8.67
98	18.67	82	8.00
97	18.00	81	7.33
96	17.33	80	6.67
95	16.67	79	6.00
94	16.00	78	5.33
93	15.33	77	4.67
92	14.67	76	4.00
91	14.00	75	3.33
90	13.33	74	2.67
89	12.67	73	2.00
88	12.00	72	1.33
87	11.33	71	0.67
86	10.67	70	0.00
85	10.00		

The maximum Technical Score, including any extra credit given for warranties or guarantees, shall not exceed 100 points in determining the Quality Credit percentage.

If any of the Technical Proposals are considered non-responsive, the State Contract Officer will notify those Design-Build Teams of that fact. The State Contract Officer shall publicly open the sealed Price Proposals and multiply each Design-Build Team's Price Proposal by the Quality Credit Percentage earned by the Design-Build Team's Technical Proposal to obtain the Quality Value of each Design-Build Team's Technical Proposal. The Quality Value will then be subtracted from each Design-Build Team's Price Proposal to obtain an Adjusted Price based upon Price and Quality combined. Unless all Proposals are rejected or the Department elects to proceed with the Best and Final Offer process, the Department will recommend to the State Transportation Board that the Design-Build Team having the lowest adjusted price be awarded the contract. The cost of the Design-Build contract will be the amount received as the Price Proposal.

The following table shows an example of the calculations involved in this process.

An Example of Calculating Quality Adjusted Price Ranking

Proposal	Technical Score	Quality Credit (%)	Price Proposal (\$)	Quality Value (\$)	Adjusted Price (\$)
A	95	16.67	3,000,000	500,100	2,499,900
B	90	13.33	2,900,000	386,570	2,513,430
C *	90	13.33	2,800,000	373,240	2,426,760
D	80	6.67	2,700,000	180,090	2,519,910
E	70	0.00	2,600,000	0	2,600,000
* Successful Design-Build Team – Contract Cost \$2,800,000					

Opening of Price Proposals

Prior to opening the Price Proposals, the State Contract Officer will provide to each Design-Build Team their Technical Score in a sealed envelope. The sealed envelope will contain that Team's score only.

At the time and date specified, the State Contract Officer will open the Price Proposals and calculate the percentage difference between the Price Proposals submitted and the Engineer's Estimate.

Should all of the Price Proposals be within an acceptable range or below the Engineer's Estimate the State Contract Officer will proceed to calculate the quality credit and publicly read the Price Proposal, Technical Score, and Adjusted Price as outlined in the selection procedure above.

Should any one or more of the Price Proposals be within an acceptable range or below the Engineer's Estimate and the remaining Price Proposals exceed an acceptable range of the Engineer's Estimate the State Contract Officer will go to a separate location to calculate the quality credit and determine if the Design-Build Team with the lowest Adjusted Price is within an acceptable range of the Engineer's Estimate. Should the Price Proposal of the Design-Build Team with the lowest Adjusted Price be within an acceptable range of the Engineer's Estimate or below the Engineer's Estimate the State Contract Officer will proceed to publicly read the Price

Proposals, Technical Scores, and Adjusted Prices. Should the Price Proposal of the Design-Build Team with the lowest Adjusted Price exceed an acceptable range of the Engineer's Estimate the State Contract Officer will publicly read the Price Proposals only and the Department will then determine whether to proceed to request a Best and Final Offer (BAFO) as outlined below.

Should all Price Proposals submitted exceed an acceptable range of the Engineer's Estimate the State Contract Officer will publicly read the Price Proposals only. The Department will then determine whether to proceed to request a Best and Final Offer (BAFO) as outlined below.

In the event that the Department elects to not proceed with a Best and Final Offer (BAFO), then the State Contract Officer will schedule a date and time to publicly reiterate all Price Proposals, and read all Technical Scores and Adjusted Prices.

Provided the Department elects to proceed to request a Best and Final Offer (BAFO), at the date and time specified, the State Contract Officer will open the Best and Final Offer Price Proposals and proceed to publicly read all Price Proposals, Technical Scores and Adjusted Prices.

Best and Final Offer

In the event initial Price Proposals exceed an acceptable range of the Engineer's Estimate or if the Department feels it is necessary for any reason the Department may choose to make amendments to the details of the RFP and request a Best and Final Offer from all of the previously short-listed teams. Alternately, the Department may choose to redistribute to the short-listed Design-Build Teams another RFP for the project with no amendments to the RFP scope.

After receipt of the redistributed RFP, the Design-Build Team has the option of changing their Technical Proposal details. If the Design-Build Team changes any component of the Technical Proposal, the TRC will review those amended components of the Technical Proposal and reevaluate the scores accordingly. The Design-Build Team shall highlight the changes to bring them to the Department's attention. A revised total score will be calculated, if appropriate, based on these amendments to the Technical Proposal.

Additional oral interviews will not be held. The Design-Build Teams shall submit both a revised Price Proposal and a revised Technical Proposal (if applicable) at the time, place, and date specified in the redistributed RFP. A revised Quality Credit Percentage (if required) and Adjusted Price will be determined. This will constitute the Design-Build Team's Best and Final Offer. Award of the project may be made to the Design-Build Team with the lowest Adjusted Price on this Best and Final Offer for the project.

Stipend

A stipulated fee of **\$75,000** will be awarded to each short-listed Design-Build Team that provides a responsive, but unsuccessful, Design-Build Proposal. If a contract award is not made, all short-listed Design-Build Teams that provide a responsive Design-Build Proposal shall receive the stipulated fee. Once award is made, or a decision is made not to award, unsuccessful Design-Build Teams can apply for the stipulated fee by notifying the State Contract Officer in writing and providing an original invoice. If the Design-Build Team accepts the stipulated fee,

the Department reserves the right to use any ideas or information contained in the Design-Build Proposals in connection with any contract awarded for the project, or in connection with any subsequent procurement, with no obligation to pay additional compensation to the unsuccessful Design-Build Team. The stipulated fee shall be paid to eligible Design-Build Teams within ninety days after the award of the contract or the decision not to award. Unsuccessful Design-Build Teams may elect to refuse payment of the stipulated fee and retain any rights to its Design-Build Proposal and the ideas and information contained therein.

In the event that the Department suspends or discontinues the procurement process prior to the Design-Build Proposal submittal date current at the time of the suspension, no stipulated fee will be paid.

ROADWAY SCOPE OF WORK (10-21-11)

Throughout this RFP, for reference purposes only, the eastbound direction extends from I-77 to US 521.

Project Details

- The Design-Build Team shall design and construct an additional through lane in each direction of I-485, providing a minimum 46-foot median, from west of the I-77 / I-485 interchange to east of the I-485 / US-521 interchange in Mecklenburg County. Unless noted otherwise elsewhere in this RFP, the Design-Build Team shall design and construct the -L- Line providing the same or better access, widening, improvements and level of service included in the R-4902 Public Hearing Map provided by the Department. The limits of -L- Line construction shall be of sufficient length to tie to existing based upon the current NCDOT guidelines and standards. The mainline shall be designed and constructed to meet a 70-mph design speed for a level freeway designed to interstate standards. The Design-Build Team shall provide all other design criteria in the Technical Proposal.
- The Design-Build Team shall design and construct the I-485 / US 521 interchange in accordance with the interchange configuration depicted on the Public Hearing Map. Any deviation to this interchange configuration shall require an approved Alternative Technical Concept. (Reference the Alternative Technical Concepts and Confidential Questions Project Special Provision found elsewhere in this RFP)
- Along the -L- Line, the Design-Build Team shall provide 12-foot outside shoulders, ten-foot of which shall be full depth paved shoulders.
- Along the -L- Line, the Design-Build Team shall design and construct 14-foot median shoulders, 12-foot of which shall be full depth paved shoulders. The median shoulders shall be designed and constructed to accommodate a future travel lane with appropriate cross slope.
- The Design-Build Team shall provide milled rumble strips along the mainline outside and inside paved shoulders, including acceleration, deceleration and auxiliary lanes, and ramps to the back of the gore (12-foot width).
- As shown on the R-4902 Public Hearing Map provided by the Department, the Design-Build Team shall design and construct modifications to the US 521 Ramps -RPC- and -RPDB- and Loop -LPC-. With the exception of resurfacing, construction is not anticipated for all other ramps / loops. Should the Design-Build Team's design and / or construction method impact the existing ramps or loops located outside the US 521 interchange, the Design-Build Team shall restore the ramp / loop horizontal and vertical alignments to pre-construction conditions or better. The following minimum requirements shall apply to all new ramps / loops and all existing ramps / loops impacted by the Design-Build Team's design and / or construction methods, excluding resurfacing:

- The Design-Build Team shall design and construct one-lane ramps that provide a minimum 16-foot lane width. The Design-Build Team shall design and construct two lane ramps that provide minimum 12-foot lanes. One-lane and two-lane ramps shall have 14-foot outside shoulders, four-foot of which shall be full depth paved shoulders and 12-foot inside shoulders, four-foot of which shall be full depth paved shoulders.
- The Design-Build Team shall design and construct loops that adhere to Exhibit 3-51, *Design Widths of Pavements for Turning Roadways*, shown in AASHTO's *A Policy on Geometric Design of Highways and Streets* (2004) - Case II / Condition C for one-lane loops; Case III / Condition C for two-lane loops. All loops shall have 12-foot outside shoulders, four-foot of which shall be full depth paved shoulders. All loops shall have 2'-6" curb and gutter along the inside edge of pavement, with a 14-foot berm. Unless noted otherwise elsewhere in this RFP, the minimum loop design shall be 30-mph with a minimum 250-foot radius.
- The Department will provide an R-4902 approved Interchange Modification Report (IMR). If the Design-Build Team revises the roadway design such that the approved IMR is nullified, the Design-Build Team shall re-analyze the interchange and complete a revised IMR, if necessary, for NCDOT and FHWA review and approval.
- Unless noted otherwise elsewhere in this RFP, the Design-Build Team shall design and construct at-grade intersections with the lane configurations noted in the R-4902 Congestion Management Recommendations Memo dated October 2010. All turn lane lengths shall meet the current NCDOT standards where vehicle storage does not govern or the lengths required by the aforementioned Congestion Management Recommendations, whichever is greater. This determination shall be made by calculating the recommended treatment for turn lanes, incorporating the minimum deceleration lengths as defined in the NCDOT Roadway Design Manual, (Reference Section 9-1, Figure F-4A) and comparing the calculated values with the NCDOT minimum turn lane lengths. At all intersections impacted by the Design-Build Team's design and / or construction, excluding resurfacing, the Design-Build Team shall accommodate the right turn maneuver in accordance with the NCDOT Roadway Design Manual (Reference Section 9-1, Figure F-4C).
- The Design-Build Team shall provide three exclusive eastbound right turn lanes and two exclusive eastbound left turn lanes on the US 521 Ramp -RPC-.
- The mainline grade point shall be located at the median edge of the existing inside lane. In a normal crown section, the existing mainline lanes shall slope in the same direction from the pavement edge adjacent to the existing median shoulder to the outside edge of pavement at a 0.02 cross slope. In a normal crown section, the proposed median mainline lane shall slope from the pavement edge adjacent to the existing median shoulder to the inside edge of pavement at a 0.02 cross slope.
- Unless noted otherwise elsewhere in this RFP, the Design-Build Team shall design and construct -Y- Lines, ramps, service roads and cul-de-sacs providing the same or better access, widening, improvements and level of service included in the R-4902 Public Hearing Map

provided by the Department. The limits of -Y- Line and service road construction shall be of sufficient length to tie to existing based upon the current NCDOT guidelines and standards.

- The Design-Build Team shall design and construct bridge rail offsets as indicated in the NCDOT *Roadway Design Manual* or that are equal to the approach roadway paved shoulders, whichever is greater. Narrower bridge rail offsets based on bridge length will not be allowed.
- Unless noted otherwise elsewhere in this RFP, all guardrail / guiderail placement shall be in accordance with the January 2012 NCDOT Roadway Standard Drawings and / or approved details in lieu of standards. Along all 3:1 fill slopes, constructed at fill heights that are equal to or greater than 12 feet, the Design-Build Team shall install guardrail. Along all fill slopes steeper than 3:1, constructed at fill heights that are equal to or greater than six feet, the Design-Build Team shall install guardrail. The guardrail / guiderail design shall be submitted for review with the Preliminary Plans submittal.
- Unless noted otherwise elsewhere in this RFP, the maximum allowable cut and fill slope shall be 2:1 (Reference the Geotechnical Engineering Scope of Work found elsewhere in this RFP). The slopes in the interchange area shall follow the requirements set forth in the *Roadway Design Guidelines for Design-Build Projects* located on the Design-Build web site.
- Within the vehicle recovery area, the Design-Build Team shall design and construct single face concrete barrier in front of all sound barrier walls located on the outside shoulder in fill sections, retaining walls and all elements acting as a retaining wall.
- Unless noted otherwise elsewhere in this RFP, the Design-Build Team shall design and construct all lane drops from the outside travelway.
- It is anticipated that all construction will be performed within the existing right of way. The Design-Build Team shall provide all services and costs required for acquiring all additional right of way and / or easements, including but not limited to direct payments to property owners for negotiated settlements, recording fees, relocation benefits, and deposits and fees involved in the filing of condemnation, resulting from design revisions and / or construction methods. If impacted by design and / or construction, the Design-Build Team shall be responsible for the installation / replacement of all right of way monuments and woven wire fence according to the NCDOT Standard Drawings and 2012 *Standard Specifications for Roads and Structures*.
- Excluding haul roads, the Design-Build Team shall design and construct resurfacing grades for all roadways impacted by construction. All resurfacing grades shall adhere to the design criteria and standards, provide all required pavement wedging (Reference the Pavement Management Scope of Work found elsewhere in this RFP) and adhere to the minimum requirements noted below:
 - The Design-Build Team shall resurface all lanes and shoulders of an undivided facility throughout the limits of proposed widening and construction.

- The Design-Build Team shall resurface each one-way roadway of a divided facility throughout the limits of the one-way roadway widening and construction, allowing varying resurfacing limits for the opposing directions of travel.
- For both divided and undivided facilities, the Design-Build Team shall resurface all lanes and shoulders within the outermost construction limits of all proposed widening and construction, including any gaps along the facility where construction activities are not required.
- The Design-Build Team shall resurface all existing facilities to the limits of pavement marking obliterations / revisions.
- Design exceptions will not be allowed for the -L- Line, including all ramps and loops. NCDOT prefers not to have design exceptions for the -Y- Lines and service roads. If the Design-Build Team anticipates any design exceptions, they shall be clearly noted in the Technical Proposal. Prior to requesting / incorporating a design exception into the Final Plans, the Design-Build Team must obtain prior conceptual approval from the Transportation Program Management Director and the FHWA. If approval is obtained, the Design-Build Team shall be responsible for the development and approval of all design exceptions.
- The Design-Build Team shall design and construct the sound barrier walls listed in the July 19, 2011 Final Traffic Noise Analysis and perform all geotechnical investigations necessary to design the foundations. The Design-Build Team shall be responsible for the wall envelope details. If the Design-Build Team revises the horizontal and / or vertical alignments such that greater noise impacts are possible on surrounding receptors, the Design-Build Team shall re-analyze and complete a revised noise report, if necessary, for NCDOT and FHWA review and acceptance. The July 19, 2011 Final Traffic Noise Analysis will be provided to the Design-Build Team to assist in their determination of anticipated additional noise impact on current receptors due to design changes. If adjustments to, or addition of, sound barrier walls are required as a result of design deviations, the Design-Build Team shall be responsible for all costs associated with the adjustments and / or additions.
- At all intersections impacted by the Design-Build Team's design and / or construction methods, excluding resurfacing, the following design vehicles shall be required for all turning movements:
 - WB-65 at all ramp / loop intersections with -Y- Lines
 - WB-50 at all other intersections
- The Design-Build Team shall be responsible for the evaluation of the algebraic difference in rates of cross slope (roll-over) between existing shoulders and roadways and the associated suitability for carrying traffic during construction, if necessary. In the event that the roll-over is found to be unacceptable for the proposed temporary traffic patterns, the Design-Build

Team shall be responsible for providing cross slopes that meet design standards and eliminate roll-over concerns.

- At all at-grade intersections with restricted movements impacted by the Design-Build Team's design and / or construction methods, excluding resurfacing, 5" keyed-in concrete monolithic channelization islands shall be provided.
- Functional classifications that have a defined usable shoulder width shall have the appropriately wider overall shoulder width.
- The Design-Build Team shall inform the Transportation Program Management Director, in writing, of any proposed changes to the NCDOT preliminary design, previously reviewed submittals or the Design-Build Team's Technical Proposal and obtain approval prior to incorporation. The Design-Build Team shall note in the Technical Proposal any proposed deviations to the preliminary design shown on the R-4902 Public Hearing Map provided by the Department. The Design-Build Team shall be responsible for any activities, as deemed necessary by the Department or the FHWA, resulting from changes to the NCDOT preliminary design, including but not limited to, public involvement and NEPA re-evaluation. The Department shall not honor any requests for additional contract time or compensation for completion of the required activities resulting from changes to the NCDOT preliminary design.
- The Design-Build Team shall submit Structure Recommendations and Design Criteria for NCDOT and FHWA review and acceptance prior to submittal of the Preliminary Plans. The Design-Build Team shall develop Structure Recommendations that adhere to the format noted in the March 25, 2003 and September 1, 2004 memos from Mr. Jay Bennett, PE, State Roadway Design Engineer. Unless noted otherwise elsewhere in this RFP, the design speed for all roadways shall be the greater of the minimum design speed for the facility type or the anticipated / actual posted speed plus five-mph. If a speed limit is not physically posted on an existing facility, general statutes mandate the speed limit as 55 mph, resulting in a 60 mph design speed.
- For all bridges over roadways, the Design-Build Team shall submit documentation that verifies the actual vertical clearance at all critical points.

General

- The design shall be in accordance with the 2004 AASHTO *A Policy on Geometric Design of Highways and Streets*, 2002 NCDOT *Roadway Design Manual*, including all revisions effective on the Technical Proposal submittal date, January 2012 NCDOT Roadway Standard Drawings, or as superseded by detail sheets located at http://www.ncdot.gov/doh/preconstruct/ps/std_draw/06details/default.html, *Roadway Design Policy and Procedure Manual*, *Roadway Design Guidelines for Design-Build Projects*, 2012 North Carolina Standard Specifications for Roads and Structures and the 2002 AASHTO *Roadside Design Guide*, 3rd Edition and 2006 Chapter 6 Update.

- If the NCDOT *Roadway Design Manual*, the 2004 AASHTO *A Policy on Geometric Design of Highways and Streets*, the 2012 Roadway Standard Drawings and / or any other guidelines, standards or policies have desirable and / or minimum values, the Design-Build Team shall use the desirable values unless noted otherwise elsewhere in this RFP. Similarly, in case of conflicting design parameters, and / or ranges, in the various resources, the proposed design shall adhere to the most conservative values, unless noted otherwise elsewhere in this RFP.
- A sag vertical curve low point shall not be located on any bridge or approach slab.
- The Design-Build Team shall contact Mr. Gary W. Thompson, North Carolina Geodetic Survey Director, prior to disturbing any geodetic monuments.
- The project shall follow the NCDOT-FHWA Oversight Agreement. This agreement will be provided. Any changes that affect previous approvals shall be re-submitted by the Design-Build Team for FHWA acceptance.
- The Design-Build Team shall identify the need for any special roadway design details (i.e. any special drainage structures, rock embankment, rock plating, special guardrail, retaining walls, concrete barrier designs, etc.) and shall provide special design drawings. The Contract Standards and Development Unit may have special details available that can be provided to the Design-Build Team upon request.

NCDOT Information Supplied

- The NCDOT will provide copies of the R-4902 Categorical Exclusion, the latest list of environmental commitments and all pertinent approvals and correspondence. The Design-Build Team shall adhere to all commitments stated in the environmental documents.
- The NCDOT will provide electronic surveys to the Design-Build Team. Any supplemental surveys, including but not limited to additional topography, existing and proposed roadway, structure sites, underground and overhead utilities, existing and proposed drainage, wetland delineation, right of way, parcel names, and deed research and descriptions shall be the responsibility of the Design-Build Team to acquire and process. Known existing utilities have been located and will be included with the survey data. The Design-Build Team shall be responsible for confirming the location of the utilities and the type / size of facilities. All supplemental Subsurface Utility Engineering (SUE) work shall be the responsibility of the Design-Build Team.
- The NCDOT will provide the R-4902 Public Hearing Map developed by the Department. The Design-Build Team is cautioned that the preliminary designs shown on the aforementioned map are provided solely to assist the Design-Build Team in the development of the project design. The Design-Build Team shall be fully and totally responsible for the accuracy and completeness of the project design, including, but not limited to, the use of the NCDOT's design, the use of portions of the NCDOT's design or modifications to the NCDOT's design.

- The NCDOT will provide final pavement designs for R-4902. The Design-Build Team shall be responsible for all temporary pavement designs. (Reference the Pavement Management Scope of Work found elsewhere in this RFP)
- The NCDOT will provide a Geotechnical Subsurface Investigation for R-4902. The Design-Build Team shall be responsible for any additional geotechnical information, all geotechnical recommendations, as well as supplemental structural and roadway investigations. (Reference the Geotechnical Engineering Scope of Work found elsewhere in this RFP)

PAVEMENT MANAGEMENT SCOPE OF WORK (10-21-11)

The pavement design for the mainline median widening, mainline auxiliary lane, median mainline paved shoulders and outside mainline paved auxiliary lane shoulders shall consist of one of the following alternates:

<u>Alternate 1</u>	<u>Alternate 2</u>	<u>Alternate 3</u>
3.0” S9.5D	3.0” S9.5D	3.0” S9.5D
4.0” I19.0D	4.0” I19.0D	4.0” I19.0D
11.5” B25.0C	7.0” B25.0C	5.5” B25.0C
Subgrade Stabilization	10.0” ABC	8.0” CTABC
	Subgrade Stabilization	Subgrade Stabilization

The alternate chosen shall be used for the entire length of the project. The Design-Build Team shall specify in their Technical Proposal which pavement alternate will be used for the project.

Subgrade Stabilization shall be to a minimum depth of 8 inches for lime and 7 inches for cement. The type of subgrade stabilization and the amount of stabilizing agent shall be determined in accordance with the Cement and Lime Stabilization of Subgrade Soils Project Special Provision found elsewhere in this RFP.

Other pavement designs for this project are listed in the table below:

LINE	Surface	Intermediate	Base
-Y8- (US 521)	3.0” S9.5C	3.0” I19.0C	8.0” B25.0C
-LPC-	3.0” S9.5B	3.0” I19.0B	4.0” B25.0B
-RPDB- and -RPC-	3.0” S9.5B	3.0” I19.0B	7.0” B25.0B

Warm mix asphalt will be allowed on the Y- Lines, but not on the -L- Line, ramps or loops.

The Design-Build Team shall resurface the existing -L- Line pavement, including all acceleration and deceleration lanes / ramps / loops to the back of the gore (12-foot width), with a minimum 3.0” S9.5D. The Design-Build Team shall resurface the existing -Y8- (US 521) pavement with a minimum 3.0” S9.5C. The Design-Build Team shall resurface the existing pavement of -RPDB-, -RPC- and -LRPC- with a minimum 3.0” S9.5B.

Unless noted otherwise elsewhere in this RFP, the minimum narrow widened width shall be six feet. The minimum narrow widened width may be reduced to four feet only if the Design-Build Team demonstrates that their equipment properly compacts narrow widening and obtains prior Department approval. Tapers that tie proposed pavement to existing pavement are excluded from the narrow widening requirements noted above.

In areas where the existing paved shoulders are proposed to be incorporated into a permanent travel lane, the Design-Build Team shall be responsible for evaluating the existing paved

shoulder regarding its suitability for carrying the projected traffic volumes. In the event that the existing paved shoulder is found to be inadequate, the Design-Build Team shall be responsible for upgrading the existing paved shoulder to an acceptable level or replacing the existing paved shoulder. The Design-Build Team shall submit their evaluation and proposed use of existing paved shoulders to the Transportation Program Management Director for review and acceptance or rejection.

The Design-Build Team shall be responsible for the design of all temporary pavements and for the evaluation of existing shoulders and roadways regarding their suitability for carrying traffic during construction, if necessary. In the event that the existing shoulders and roadways are found to be inadequate for the proposed temporary traffic volumes and duration, the Design-Build Team shall be responsible for upgrading the pavement to an acceptable level. Temporary pavements shall be designed in accordance with the most recent version of the North Carolina DOT Pavement Design Procedure. Temporary pavement designs shall be submitted for review and comments using the contract submittal process. The expected duration for traffic on temporary pavement must be included as part of the submittal.

All driveways, up to the radius point, shall be constructed with the full-depth pavement design of the intersecting roadway. The entire impacted length of all non-concrete driveways with a 10% or steeper grade shall be constructed with 1.5" S9.5B and 8.0" ABC. Unless otherwise noted above, the Design-Build Team shall adhere to the following for all driveway construction:

For existing gravel and soil driveways, use 8.0" ABC.

For existing asphalt driveways, use 1.5" S9.5B and 8.0" ABC.

For existing concrete driveways, use 6.0" jointed concrete reinforced with woven wire mesh.

The rate of application and the maximum and minimum thickness per application and layer shall be in accordance with the NCDOT Roadway Design Manual.

The Design-Build Team shall be responsible for the design and construction of shoulder drains and outlets for the mainline median widening and the mainline auxiliary lane. Along sides of the mainline that are widened, shoulder drains shall be provided for typical crown sections, on the low side of superelevated sections, throughout all sag vertical curves, throughout crest vertical curves located in cut sections, and where the grade is less than 1%. Where installed on the outside shoulder, outlets shall be provided approximately every 300 feet. Where installed on the median shoulder, outlets shall be provided at drainage structures at increments not to exceed 500 feet. Shoulder drains shall be placed to drain the entire pavement structure. The shoulder drain design and outlet locations shall be submitted to the Transportation Program Management Director for review and acceptance or rejection.

The Design-Build Team shall pave from the edge of the proposed paved shoulder to the face of sound barrier walls located on the outside shoulder in fill sections and to the face of all guardrails with 6.0" of ABC (or 4.0" B25.0B or B25.0C), prime coat at the normal application rate and at least one lift of surface course. In these areas, the Design-Build

Team's installation of ABC or black base shall be consistent with the pavement type for the specific roadway. As an alternative to the above pavement design for paving the shoulders to the face of the guardrail, the Design-Build Team may use the adjacent travel lane pavement design.

When a resurfacing grade ties to existing pavement, the Design-Build Team shall perform incidental milling, such that the new pavement ties flush with the existing pavement. When tying to the existing pavement, the Design-Build Team shall not reduce the minimum required surface layer pavement thickness noted above. The Design-Build Team shall not perform incidental milling more than 72 hours prior to placement of the asphalt surface layer.

STRUCTURES SCOPE OF WORK (10-21-11)**Project Details**

The Design-Build Team shall be responsible for all structures necessary to complete the project, including:

- Flyover from US 521 northbound (Johnston Rd.) to I-485 westbound
- Sound barrier walls listed in the July 19, 2011 Final Traffic Noise Analysis
- All retaining walls

The Design-Build Team shall widen and rehabilitate, as noted herein, the following structures:

- Dual Bridges on -L- (I-485) over Sugar Creek
- Dual Bridges on -L- (I-485) over SR 1128 (Westinghouse Bpulevard)
- Dual Bridges on -L- (I-485) over Little Sugar Creek, including but not limited to retrofit required to accommodate a sound barrier wall
- Dual Bridges on -L- (I-485) over NC 51 (Pineville-Matthews Road)
- Dual Bridges on -L- (I-485) over McMullen Creek
- Dual Bridges on -L- (I-485) over McAlpine Creek and Greenway

All other existing bridges that carry roadways over -L- (I-485) require installation of concrete barriers or guardrails for median pier protection. Reference the Roadway Scope of Work.

The Design-Build Team shall be responsible for all required railroad coordination to construct the widening of -L- (I-485) under existing Bridge No. 645, including but not limited to securing Railroad Agreements. (Reference the Railroad Coordination Scope of Work found elsewhere in this RFP)

All existing reinforced concrete box culverts (RCBC) shall be retained. It is anticipated that the existing RCBC will not require additional conveyance or lengthening. However, the Design-Build Team shall lengthen the existing reinforced concrete box culverts as required by the Design-Build Team's design and / or construction methods.

All bridges shall meet approved roadway typical sections and grades. Bridge geometry (width, length, skew, span arrangement, etc.) shall be in accordance with the accepted Structure Recommendations prepared by the Design-Build Team.

Cored slab, box beam, fracture critical, cast-in-place deck slab and deck girder bridges will not be allowed on this project.

All proposed bridge barrier rails shall be jersey shaped barrier rail, per Standard Drawing CBR1. Precast barrier rails will not be allowed.

The empirical method for deck design will not be allowed.

A live load rating chart for both existing and proposed girders shall be included with the bridge plans and shall state design assumptions and methodology used in the load rating calculations. Regardless of the rating of existing girders, these girders do not need to be replaced. The load

rating shall be in accordance with the NCDOT *Structure Design Manual* (including policy memos) and *AASHTO's Manual for Bridge Evaluation*.

Sound barrier walls shall be in accordance with Structure Standards SBW1 and SBW2 and the Sound Barrier Wall Project Special Provision located on the Structure Design Unit website or alternate details and special provisions approved by the NCDOT Structure Design Unit, Geotechnical Engineering Unit, and Human Environment Unit. Concrete piles are permitted provided adequate connection details are used.

Bridge Widening and Rehabilitation

The Design-Build Team shall provide closure pours with cross-joint reinforcement / dowels. Intermediate diaphragms are not required in the closure bay. The Design-Build Team shall provide bent diaphragms in the closure bay and the plans shall reflect that these diaphragms be connected and bolts tensioned prior to the deck pour. Diaphragms for all other bays shall be included as per the NCDOT *Structure Design Manual* (including policy memos).

The Design-Build Team shall replace all preformed compression joints with unarmored, sawed evazote joints with elastomeric concrete.

For bridges that require widening, the Design-Build Team shall overlay the existing and widened decks and approach slabs with latex modified concrete. The Design-Build Team shall mill the existing decks and approach slabs or perform Class I and Class IA Surface Preparation on all twelve bridges. Following the milling, the Design-Build Team shall provide Class II and / or Class III Surface Preparation, for areas which are found to be unsound or delaminated as determined by the Engineer. In such case, the Class II and Class III repairs will be paid for as extra work in accordance with Subarticle 104-8(A) of the 2012 *Standard Specifications for Roads and Structures* at the price of \$300 per square yard and \$700 per square yard, respectively.

Using System 4 of Article 442-7 of the 2012 *Standard Specifications for Roads and Structures*, the Design-Build Team shall paint the free ends of the existing and proposed steel beams / girders for Bridge Nos. 606 and 607.

The Design-Build Team shall repair and extend the existing slope protection completely across the median, forming continuous slope protection at all widened bridges. The slope protection shall extend up the slope to the end of end bent wings in the median.

General

The Design-Build Team's primary design firm shall be on the Highway Design Branch list of firms qualified for structure design and maintain an office in North Carolina.

Design shall be in accordance with the latest edition of the *AASHTO LRFD Bridge Design Specifications* (with exceptions noted in the NCDOT *Structure Design Manual*), NCDOT LRFD Driven Pile Foundation Design Policy, NCDOT *Structure Design Manual* (including policy memos) and NCDOT Bridge Policy Manual except as noted otherwise elsewhere in this RFP.

Construction and materials shall be in accordance with NCDOT 2012 *Standard Specifications for Roads and Structures*, NCDOT Structure Design Unit Project Special Provisions and NCDOT Structure Design Unit Standard Drawings.

Alternate designs, details or construction practices (such as those employed by other states, but not standard practice in NC) are subject to Department review and approval, and will be evaluated on a case by case basis.

Attachment of sign structures to bridges will not be allowed.

Any required bridge attachments (e.g. signal lines) will not be allowed in the overhang of grade separations. Casting of conduit in the bridge deck or barrier rail will not be allowed.

GEOTECHNICAL ENGINEERING SCOPE OF WORK (10-24-11)**I. GENERAL**

Obtain the services of a firm prequalified for geotechnical work by the Highway Design Branch List. The prequalified geotechnical firm shall prepare foundation design recommendation reports for use in designing structure foundations, roadway foundations, retaining walls, sound barrier foundations, overhead sign structure and luminary foundations, and temporary structures.

The Engineer of Record who prepares the foundation design recommendation reports shall be a Professional Engineer registered in the State of North Carolina who has completed a minimum of three geotechnical design projects of scope and complexity similar to that anticipated for this project using the load and resistance factor design (LRFD) method and in accordance with the latest edition of the AASHTO *LRFD Bridge Design Specification*. If the Engineer of Record cannot demonstrate the aforementioned LRFD experience, then the design must undergo a peer review by an individual with such experience. In such case, the reviewer must be a registered Professional Engineer, but not necessarily in the State of North Carolina. Prior to the first geotechnical design submittal, the Design-Build Team shall provide a letter to the NCDOT Design-Build Office that documents the reviewer's LRFD experience for review and acceptance. Furthermore, with each geotechnical design submittal, the reviewer shall provide a sealed letter stating that he / she has carefully reviewed and approved the specific submittal details.

The prequalified geotechnical firm shall also determine if additional subsurface information, other than that required and noted elsewhere in this RFP, is required based upon the subsurface information provided by the NCDOT and the final roadway and structure designs. If a determination is made that additional subsurface information is required; the Design-Build Team shall use a prequalified geotechnical firm to perform all additional subsurface investigation and laboratory testing in accordance with the current NCDOT Geotechnical Engineering Unit *Guidelines and Procedures Manual for Subsurface Investigations*. Submit additional information collected by the Design-Build Team to the Geotechnical Engineering Unit for review. The Design-Build Team shall provide the final Subsurface Investigation report in electronic and hardcopy format to the NCDOT for its records.

A minimum of 2 standard penetration test (SPT) / rock core borings shall be required per bent for all bridges except dual bridges. A minimum of 3 SPT / rock core borings shall be required across the roadway typical section, at each bent location for dual bridges. All borings shall be located within 100 feet of the centerline of each bent location to be counted for these minimum requirements. Extend all borings to a depth below the foundation element required to show a complete subsurface profile. The Design-Build Team shall be responsible for obtaining the borings noted above for all bents where subsurface information is not sufficient or is warranted by variability in the geology unless the prequalified geotechnical firm submits documented justification that the subsurface investigation provided by the NCDOT is adequate for design purposes and the

justification is acceptable to the Department. Any deviations to the requirements noted above shall require acceptance from the NCDOT Geotechnical Engineering Unit prior to construction.

The maximum spacing between borings for retaining walls and sound barrier walls shall be 200 feet, with a minimum of two borings; one at each end of the wall. Drill borings for retaining walls a minimum depth below the bottom of the wall equal to twice the maximum height of the wall. Boring depths for sound barriers shall be equal to the maximum height of the wall or to SPT refusal.

The Design-Build Team is permitted to design bridges on this project using software that accounts for the structural effects of soil / pier interaction.

II. DESCRIPTION OF WORK

Unless otherwise noted herein, the Design-Build Team shall design foundations (except sign foundations), embankments, slopes, retaining walls, and sound barrier walls in accordance with the current edition of the AASHTO *LRFD Bridge Design Specifications*, NCDOT *LRFD Driven Pile Foundation Design Policy*, all applicable NCDOT Geotechnical Engineering Unit Standard Provisions, NCDOT *Structure Design Manual*, and NCDOT *Roadway Design Manual*. The NCDOT *LRFD Driven Pile Foundation Design Policy* is located on the NCDOT Geotechnical Engineering Unit's website at:

<http://www.ncdot.org/doh/preconstruct/highway/geotech/LRFDPolicy/>

For *Geotechnical Guidelines for Design-Build Projects*, the Design-Build Team shall adhere to the guidelines located at the following website:

http://www.ncdot.org/doh/preconstruct/altern/design_build/default.html

A. Structure Foundations

Key in spread footings of structures crossing streams a minimum of full depth below the 100-year design scour elevation and provide scour protection in accordance with scour protection detail in the NCDOT *Structure Design Manual*.

Permanent steel casings shall be required for drilled piers that are constructed in six inches or more of water. Permanent steel casings are required for drilled piers constructed on sloped stream banks subject to degradation from flooding.

When the weathered rock or rock elevation is below the 100-year hydraulic scour elevation, the 100-year and 500-year design scour elevations are equal to the 100-year and 500-year hydraulic scour elevations from the structure survey report accepted by the NCDOT Hydraulics Unit. When the weathered rock or rock elevation is above the 100-year hydraulic scour elevation, the 100-year design scour elevation may be considered equal to the top of the weathered rock or rock elevation, whichever is higher, and the 500-year design scour elevation may be set two feet below the 100-year design scour elevation.

End bent fill slopes up to 35 feet in height (defined as the difference between grade point elevation and finished grade at toe of slope) shall be 1.5:1 (H:V) or flatter. End bent fill slopes with heights greater than 35 feet shall be 2:1 or flatter. All end bent cut slopes shall be 2:1 or flatter. For 1.5:1 fill slopes, extend end bent slope protection from the toe of slope to berm and to 1.75:1 (H:V) slope or to the limits of the superstructure. For cut slopes and for 2:1 or flatter end bent fill slopes, extend end bent slope protection from the toe of slope to berm and to the limits of the superstructure.

Analyze drilled pier and pile bent foundations using either LPile or FB-Pier. Design drilled piers and vertical piles with a sufficient embedment in soil and / or rock to achieve “fixity”.

Design sound barrier wall foundations in accordance with current allowable stress design AASHTO Guide Specifications for Structural Design of Sound Barriers. A minimum factor of safety of 1.5 shall be required for shaft embedment depths.

B. Roadway Foundations

Unless otherwise noted herein, all unreinforced proposed fill slopes shall be 2:1 (H:V) or flatter except bridge end bent slopes (see Section A – Structure Foundations). All proposed soil cut slopes shall be 2:1 (H:V) or flatter, unless the slopes are designed with adequate reinforcement to provide the required stability. If steeper than 2:1 (H:V), all reinforced cut slopes, rock cuts and fill slopes shall only be used if detailed design calculations and a slope stability analysis are submitted to the NCDOT Geotechnical Engineering Unit, via the Transportation Program Management Director, for review and acceptance prior to construction.

Design and construct bridge approach embankments such that no more than ½- inch of settlement shall occur after the waiting periods end or embankment fill is constructed to subgrade elevation. Soil improvement techniques to mitigate long term settlement problems or to transfer the embankment load to a deeper bearing stratum are allowed. Soil improvement techniques shall follow the current industry standard practices and the guidelines of *Ground Improvement Methods FHWA publication NHI-04-001* or *Geosynthetic Design and Construction Guidelines FHWA-HI-95-038*.

Embankment settlement monitoring shall be required when a waiting period of more than one month is recommended in the foundation design recommendation reports. Settlement monitoring of approach fills shall be required when their heights exceed 15% of total fill height. Approach fill height is defined as difference between proposed grade and bottom of cap elevations. Use an appropriate method to monitor settlement across the length of the embankment (from toe to toe) such as settlement gauges, surveyed stakes on finished subgrade or other methods; but submit documentation describing the method and procedures to the NCDOT Geotechnical Engineering Unit, via the Transportation

Program Management Director, for review and acceptance prior to construction of the embankment.

Reinforced bridge approach fills in accordance with the NCDOT standard shall be required for end bents on all bridges.

Mitigate all unsuitable soils to the extent that is required to improve the stability of the proposed embankment or subgrade. Use suitable material to backfill undercut areas except when employing shallow undercut in accordance with Section 505 of the NCDOT 2012 *Standard Specifications for Roads and Structures* which requires the use of Select Material, Class IV. For undercut backfilling in water, use Select Material, Class III.

C. Permanent Retaining Wall Structures

For design and construction of mechanically stabilized earth (MSE) retaining walls, refer to the NCDOT *Policy for Mechanically Stabilized Earth Retaining Walls* which can be found at the NCDOT Geotechnical Engineering Unit's website at:

http://www.ncdot.org/doh/preconstruct/highway/geotech/msewalls/10-07-19_MSE_Retaining_Walls_Policy.pdf

Design and construct permanent retaining walls, with the exception of gravity walls, in accordance with the applicable NCDOT Geotechnical Engineering Unit *Project Special Provisions*, which can be provided upon request by the Design-Build Team. Geotechnical Provisions and Notes can be found at the NCDOT Geotechnical Engineering Unit's website at:

<http://www.ncdot.org/doh/preconstruct/highway/geotech/provnote/>

For each retaining wall, with the exception of gravity walls, submit a wall layout and design. The wall layout submittal shall include the following:

- Wall envelope with top of wall, bottom of wall, existing ground and finished grade elevations at incremental stations
- Wall alignment with stations and offsets
- Typical sections showing top and bottom of wall, drainage, embedment, slopes, barriers, fences, etc.
- Calculations for bearing capacity, global stability and settlement
- Details of conflicts with utilities and drainage structures
- Roadway plan sheets showing the wall (half size)
- Roadway cross sections showing the wall (half size)
- Traffic control plans showing the wall (half size)

Gravity walls shall be designed and constructed in accordance with the NCDOT Structure Standard Drawings and the NCDOT 2012 *Standard Specifications for Roads and Structures*. Gravity walls shall be identified in the roadway foundation design recommendation report. Cast-in-place cantilever walls shall be designed

and constructed in accordance with the NCDOT 2012 *Standard Specifications for Roads and Structures*. Conceptual wall layouts and wall designs shall be submitted for NCDOT for review and acceptance.

Locate retaining walls at toes of slopes unless restricted by right of way limits. The Design-Build Team shall submit global stability calculations for slopes at retaining walls and obtain acceptance from the NCDOT prior to construction. Any slopes behind walls shall be 2:1 (H:V) or flatter.

Drainage over the top of retaining walls shall not be allowed. Sags in the top of walls shall not be allowed. Direct runoff above and below walls away from walls, if possible, or collect runoff at the walls and transmit it away. Curb and gutter or cast-in-place single faced barrier with paving up to the wall shall be required when runoff can not be directed away from the back or front of the wall. A paved concrete ditch with a minimum depth of six inches shall be required at the top of walls when slopes steeper than 6:1 (H:V) intersect the back of walls.

Precast or cast-in-place coping shall be required for walls without a cast-in-place face with the exception of when a barrier is integrated into the top of the wall. Extend coping or cast-in-place face a minimum of six inches above where the finished or existing grade intersects the back of the wall. To provide potential fall protection, a chain link fence shall be required on top of the facing, coping or barrier, or immediately behind the wall, if there is no slope behind the wall.

Deep foundations shall be used for end bents when abutment retaining walls are employed. When using abutment retaining walls, design and construct the end bent and the wall independent of each other. When using abutment retaining walls, the end bent foundation shall be designed and constructed with one of the following deep foundations: (1) a single row of plumb piles with brace piles battered toward the wall, (2) a single row of plumb piles with MSE reinforcement connected to the back of the cap, (3) a double row of plumb piles (4) integral abutment with a single row of plumb piles and not reinforcement connected to the back of the cap, in accordance with FHWA GEC 11 Page Nos. 6–8 through 6-10, or (5) drilled piers. If fill is required around piles or drilled piers, install foundations before placing any fill. Wing walls independent of abutment retaining walls shall be required unless accepted otherwise by the NCDOT. Do not consider lateral support from any fill placed around drilled piers behind abutment retaining walls when analyzing end bent stability. All pile foundations for end bents with abutment retaining walls shall penetrate minimum 10 feet into natural ground. For bearing piles behind such retaining walls, the penetration can be reduced to 5 feet below the bottom of the wall provided the Design-Build Team analyzes and determines that the vertical piles are “fixed” in natural ground such that the decrease in pile embedment shall not significantly increase the top deflection under lateral loading. The calculations and supporting documentation for this analysis shall be submitted to the NCDOT for review and acceptance prior to construction.

D. Temporary Structures

Design temporary retaining structures, which include earth retaining structures and cofferdams, in accordance with current allowable stress design AASHTO *Guide Design Specifications for Bridge Temporary Works* and the *Temporary Shoring Special Provision*. The only submittal required to use the standard sheeting design is the “Standard Shoring Selection Form”.

Design and construct temporary retaining walls in accordance with the applicable NCDOT *Project Special Provision* available upon request by the Design-Build Team. Traffic Control barrier on top of walls shall be in accordance with the NCDOT Work Zone Traffic Control Unit details available upon request by the Design-Build Team. If anchored barrier is required, then anchor the barrier in accordance with NCDOT 2012 *Roadway Standard Drawing Detail No. 1170.01*.

III. CONSTRUCTION REQUIREMENTS

All construction and materials shall be in accordance with the NCDOT 2012 *Standard Specifications for Roads and Structures* and current NCDOT *Project Special Provisions* unless noted otherwise elsewhere in this RFP. The Design-Build Team shall be responsible for investigating, proposing and incorporating remedial measures for any construction problems related to foundations, retaining walls, subgrades, settlement, slopes and construction vibrations. The NCDOT Geotechnical Engineering Unit shall review and accept these proposals.

The Design-Build Team shall be responsible for any damage or claim caused by construction, including damage caused by vibration (see Article 107-14 NCDOT 2012 *Standard Specifications for Roads and Structures*). The Design-Build Team shall be responsible for deciding what, if any, pre and post-construction monitoring and inventories need to be conducted to satisfy their liability concerns. Any monitoring and inventory work shall be performed by a qualified private engineering firm experienced in the effects of construction on existing structures.

The prequalified geotechnical firm that prepared the foundation designs shall review the settlement monitoring data a minimum of once a month and issue a letter prior to releasing the embankment or approach fill from the waiting period. Waiting periods may not be ended until less than 0.10 inch of settlement is measured over a period of four weeks. Submit the settlement monitoring data to the Transportation Program Management Director prior to issuing the release letter.

The prequalified geotechnical firm that prepared the foundation designs shall review and approve all pile driving hammers and drilled pier construction sequences. After the prequalified geotechnical firm has approved these submittals, the Design-Build Team shall submit to the NCDOT for review prior to beginning construction.

Perform hammer approvals with GRLWEAP Version 2002 or later and in accordance with the NCDOT *LRFD Driven Pile Foundation Design Policy*. Provide pile driving inspection charts or tables for all approved pile hammers.

Limit driving stresses in accordance with the AASHTO LRFD *Bridge Design Specifications*. If a tip elevation is noted on the plans, drive piles to the minimum required driving resistance and tip elevation. Otherwise, drive piles to the minimum required driving resistance and a penetration into natural ground of at least 10 feet. Unless otherwise approved, stop driving piles when refusal is reached. Refusal shall be defined as 240 blows per foot or any equivalent set.

Perform Pile Driving Analyzer (PDA) testing using a NCDOT prequalified company to develop pile driving inspection charts or tables. For each permanent bridge that includes driven pile bents or driven pile footings, perform a minimum of one (1) PDA test (dual bridges are counted as one structure) for each pile size, pile type (material or shape) and pile driving hammer combination. Additional PDA tests may be required based upon the AASHTO LRFD Bridge Design Specifications. If the bridge length with driven pile foundations is longer than 400 feet, perform an additional PDA test at every 400 feet interval. Provide additional PDA testing for any revisions to pile type, size or hammer previously approved. The locations of specific piles to be tested must be accepted by the NCDOT prior to any PDA test. Perform PDA tests in accordance with ASTM D 4945-89, Standard Test Method for High Strain Dynamic Testing of Piles and this scope of work.

Analyze data with the Case Pile Wave Analysis Program (CAPWAP), version 2006 or later. At a minimum, analysis is required for a hammer blow near the end of initial drive and for each restrike and redrive. Additional CAPWAP analysis may be required as determined by the Engineer.

Meet the guidelines for NCDOT PDA reports from the Geotechnical Engineering Testing Contract for PDA test reports. To obtain a list of pre-approved Geotechnical Engineering Testing Contract companies to perform PDA testing and guidelines for PDA test report, contact the Geotechnical Engineering Unit at 919-707-6850. PDA testing may be performed by a technician, but PDA testing must be overseen and the reports sealed by a Professional Engineer registered in the State of North Carolina. Submit a complete PDA report sealed by the professional engineer who performed the test to the foundation design firm. The foundation design firm shall develop pile driving inspection charts or tables for acceptance by the NCDOT prior to pile installation.

For drilled-in piles, the following additional requirements shall apply:

1. Prequalification of contractors is not required for pile excavation or drilled-in pile holes that are 30 inches in diameter or less.
2. Use Class A Concrete in accordance with Article 1000-4 of the NCDOT 2012 *Standard Specifications for Roads and Structures* except as modified herein. Provide concrete with a slump of 6 to 8 inches. Use an approved high-range water reducer to achieve this slump. Perform pile excavation to specified elevations shown on the plans. Excavate holes with diameters that will result in at least 3 inches of clearance all around piles. Before filling holes, support and center piles in excavations and

- when noted on the plans, drive piles to the required driving resistance. Remove any fluid from excavations and fill holes with concrete.
3. Blasting for core removal is only permitted when approved by the Engineer. Dispose of drilling spoils in accordance with Section 802 of the NCDOT 2012 *Standard Specifications for Roads and Structures* and as directed by the Engineer. Drilling spoils consist of all excavated materials including fluids removed from excavations by pumps or drilling tools. If unstable, caving or sloughing soils are anticipated or encountered, stabilize excavations with either slurry or steel casing. When using slurry, submit slurry details including product information, manufacturer's recommendations for use, slurry equipment details and written approval from the slurry supplier that the mixing water is acceptable before beginning drilling. When using steel casing, use either the sectional type or one continuous corrugated or non-corrugated piece. Steel casings shall consist of clean watertight steel of ample strength to withstand handling and driving stresses and the pressures imposed by concrete, earth and backfill. Use steel casings with an outside diameter equal to the hole size and a minimum wall thickness of 1/4-inch.
 4. Check the water inflow rate at the bottom of holes after all pumps have been removed. If the inflow rate is less than 6 inches per half hour, remove any fluid and free fall concrete into excavations. Ensure that concrete flows completely around piles. If the water inflow rate is greater than 6 inches per half hour, propose and obtain acceptance of a procedure for placing concrete before filling holes. Place concrete in a continuous manner and remove all casings.

Use current NCDOT inspection forms for drilled piers available on the NCDOT Geotechnical Engineering Unit's webpage. Construct and inspect drilled piers in accordance with Section 411 of the NCDOT 2012 *Standard Specifications for Roads and Structures*. The Design-Build Team shall inspect drilled piers using their Shaft Inspection Device (SID) for any pours using the wet method of concrete placement and for any drilled pier excavations that have remained open greater than 24 hours. Install Crosshole Sonic Logging (CSL) tubes in all drilled piers. CSL test a minimum of 25% of drilled piers at each bridge or one per bent, whichever is greater. If a CSL test identifies any defect in the drilled pier, the Department has the right to request additional CSL testing as needed. The Department will determine which piers will be CSL tested. Submit CSL test information and results to the Geotechnical Engineering Unit, via the Transportation Program Management Director, for review and acceptance.

The prequalified geotechnical firm that prepared the original design shall perform any changes to the foundation designs. All changes shall be based upon additional information, subsurface investigation and / or testing. Drilled pier tip elevations shall not be changed during construction unless the prequalified geotechnical firm that prepared the bridge foundation design redesigns the drilled pier from either an SPT / rock core boring, performed in accordance with ASTM standards at the subject pier location, or observations of the drilled pier excavation. If a drilled pier is designed based on a boring, do not drill a boring inside an open drilled pier excavation. Locate the boring within three pier diameters of the center of the subject pier and drill to a depth of two pier

diameters below the revised tip elevation. If a drilled pier is redesigned based upon observations of the drilled pier excavation, the geotechnical engineer of record shall be present during the excavation to determine the actual subsurface conditions. Send copies of revised designs including additional subsurface information, calculations and any other supporting documentation sealed by a professional engineer registered in the State of North Carolina to the NCDOT for review.

Conduct proofrolling in accordance with Section 260 of the 2012 *Standard Specifications for Roads and Structures*.

Send copies of any inspection forms related to foundations, settlement or retaining walls to the NCDOT for review.

HYDRAULICS SCOPE OF WORK (10-21-11)**Project Details**

- The Design-Build Team shall employ a private engineering firm to perform hydraulic design for all work required under this contract. The private engineering firm shall be prequalified for hydraulic design work under the Department's normal prequalification procedures prior to the Technical Proposal submittal date.
- The Design-Build Team shall hold a pre-design meeting with the Transportation Program Management Director and Hydraulic Review Engineer upon acceptance of the Preliminary Roadway Plans developed by the Design-Build Team.
- The Design-Build Team shall design all storm drainage systems using Geopak Drainage.
- The Design-Build Team shall prepare a CLOMR for crossings that increase the Base Flood Elevation or provide appropriate documentation of no increase. No construction activity shall occur in FEMA regulated floodplain(s) prior to approval by Mecklenburg County. The Department will be responsible for submitting CLOMR(s) to Mecklenburg County and all associated fees.
- The Design-Build Team shall describe in the Technical Proposal the proposed superelevation, grades, etc. and how they will minimize hydroplaning concerns for this project and for the future median widening of I-485 to an eight-lane facility.
- The Design-Build Team shall design bridge drainage without the use of Bridge Scuppers (open-grated inlets). If a closed drainage system is used on a bridge, the closed drainage system shall use vertical pipes at the flow line through the deck with no elbow and shall be consistent with that shown in the current NCDOT Stormwater Best Management Practices Toolbox.
- Deck drains will not be allowed to discharge directly into any streams or onto any greenways.
- The Design-Build Team shall develop a Stormwater Management Plan using Best Management Practices as required in the most current NCDOT BMP Toolbox.
- The Design-Build Team shall provide permit drawings, calculations and impact summary sheets for USACE 404 Permit and NCDWQ Section 401 Certification.
- The Design-Build Team shall prepare Outfall Analyses for increases in discharge and take appropriate action in accordance with the guidelines stated below to make sure that additional drainage is adequately handled.
- The Design-Build Team shall use a minimum ditch grade of 0.3% and avoid using ditches in wetlands.

- Raised median island cuts will not be allowed

General

- The Design-Build Team's design shall be in accordance with criteria provided in the North Carolina Division of Highways *Guidelines for Drainage Studies and Hydraulics Design-1999* and the addendum *Handbook of Design for Highway Drainage Studies-1973*, North Carolina Department of Transportation "Stormwater Best Management Practices Toolbox – 2008" and the North Carolina Division of Highways Hydraulics Unit website:

<http://www.ncdot.org/doh/preconstruct/highway/hydro/>

- The Department will allow no direct contact between the Design-Build Team and Mecklenburg County representatives. No contact between the Design-Build Team, the Mecklenburg County and / or personnel under contract with Mecklenburg County shall be allowed either by phone, e-mail or in person, without Department representatives present. A representative from the Transportation Program Management Unit shall be included on all correspondence.

TRAFFIC MANAGEMENT SCOPE OF WORK (10-21-11)**I. Traffic Management Plans****A. Design Parameters**

The Design-Build Team shall prepare the Traffic Management Plans which includes the Temporary Traffic Control Plan, the Traffic Operations Plan, the Public Information Plan as it relates to the Traffic Control Devices and temporary pavement markings for this project following the parameters listed below.

For additional information regarding the components of the Traffic Management Plan, review the *Work Zone Safety and Mobility Policy* found on the Work Zone Traffic Control Website at:

<http://www.ncdot.gov/doh/preconstruct/wztc/>

1. Maintain the same number of existing traffic lanes using a minimum 11-foot wide lane in each direction on I-485, as well as all auxiliary lanes, except as otherwise allowed by the lane closure time restrictions. Maintain four-foot wide inside and outside paved shoulders in each direction of I-485 unless temporary barrier is placed on the paved shoulder. Under structures only, maintain a minimum two-foot wide paved shoulder adjacent to the I-485 travel lane. Under structures only, maintain a minimum one-foot wide paved shoulder adjacent to auxiliary lanes / ramps. Maintain a minimum of 11-foot wide lanes and existing shoulder widths on all the -Y- Lines and maintain existing lane and shoulder widths on all two-lane roadways.

Maintain the same number of existing travel lanes on all -Y- Lines, except as otherwise allowed by the lane closure and road closure time restrictions.

2. The Design-Build Team shall maintain positive median cross-over protection for the entire I-485 project limits. The Design-Build Team shall indicate in the Technical Proposal the type of positive protection proposed and replacement/resetting requirements.
3. All traffic control devices, including bridge barrier rails, shall be placed / located a minimum 2-foot offset (shy distance) from the edge of travel lane.
4. Use of temporary barrier system shall be shown on the Traffic Management Staging Concept. Temporary barrier systems shall be designed in accordance with the following requirements:
 - Perform an Engineering Study to determine the need for temporary barrier that considers clear zone distances, roadway geometry, anticipated construction year traffic volumes, traffic speeds, roadside geometry, workers safety, pedestrian safety, etc. in accordance with FHWA Final Rule on Temporary Traffic Control Devices (23 CFR 630 Subpart K). Reference the NCDOT Work Zone Traffic

Control website noted below for examples and Guidelines on the use of positive protection in work zones.

<http://ncdot.org/doh/preconstruct/wztc/DesRes/English/DesResEng.html>

- The Design-Build Team shall adhere to the Roadside Design Guide in determining the length of need, flare rate and clear zone. The Design-Build Team shall adhere to the possible deflection of the proposed temporary barrier system in accordance with NCHRP-350 deflections from crash testing. Providing less than the minimum deflection distance shall require the use of anchored temporary barrier systems in accordance with the NCDOT 2012 *Standard Specifications for Roads and Structures*.
 - When temporary barrier is used continuously on both sides of a direction of I-485 travel for a distance greater than one mile, provide a paved motorist breakdown area on the right side of the mainline (I-485) travel way every mile, unless the outside useable shoulder width is eight feet or greater. All breakdown areas shall be a minimum of 1000 feet long and 14 feet wide.
 - The Design-Build Team shall not place temporary barrier systems utilized for traffic control on unpaved surfaces.
5. The design speed for temporary alignments of Interstate, US and NC routes shall not be lower than the current posted speed limit. The minimum allowable design speed for temporary alignments on secondary roads shall be the higher of 10 mph below the posted speed limit or 35 mph.
 6. Temporary traffic shifts requiring vertical grades shall be considered a temporary alignment. All temporary alignments shall adhere to the *NCDOT Roadway Design Manual*, 2004 AASHTO *A Policy on Geometric Design of Highways and Streets* and the most current *Highway Capacity Manual*.
 7. 2012 *Roadway Standard Drawings Standard Drawing* No. 1101.11 shall be used for calculating the length of temporary merges for lane closures and temporary traffic shifts. For temporary traffic patterns, including but not limited to traffic shifts, merges and temporary alignments that will remain in place for a period longer than three days, breaks in the superelevation will not be allowed within the shifting taper. Excluding the aforementioned temporary traffic patterns, changes in pavement cross slopes shall only occur on a lane line or lane midpoint and shall not exceed 0.04.
 8. Maintain access to all residences, schools, bus stops, mass transit facilities (park and ride lots), emergency services and businesses at all times.
 9. Traffic traveling in the same direction shall not be split (i.e. separation by any type of barrier, bridge piers, existing median, etc.).

10. Prior to incorporation, obtain written approval from the Engineer for all road closures.
11. The Design-Build Team shall not place I-485 traffic on an offsite detour. Offsite detours shall only be allowed on the -Y- Lines for girder placement. Prior to incorporation, all offsite detour routes shall receive Department written approval and adhere to the following requirements:
- The Design-Build Team shall be responsible for investigating all detour routes, including but not limited to, analyzing traffic capacity, investigating impacts to emergency services and schools, analyzing design characteristics to ensure the design supports the traffic volumes and investigating pavement structural adequacy, including but not limited to bridge postings on the detour route.
 - The Design-Build Team shall determine and provide improvements required to accommodate detoured traffic prior to utilizing detour routes.
 - Offsite detours that have non-signalized at-grade railroad crossings shall not be allowed.
 - The Design-Build Team shall include all proposed offsite detours in the Technical Proposal, providing justification for using such detours along with duration. Possible detour warrants could include, but are not limited to, road closures due to substandard horizontal or vertical clearance limits, grade changes at tie-in locations and oversize and/or overweight limits.
 - Submit the detour route and all associated sign designs for review and acceptance prior to incorporation.
 - Use only State maintained roads for off-site detour routes.
12. On all roadways within the project limits, the Design-Build Team shall provide safe access for wide-loads and oversized permitted vehicles through the work zone. Safe access shall entail, but is not limited to, a sufficient pavement structure (Reference the Pavement Management Scope of Work found elsewhere in this RFP), required vertical clearance and minimum clear zone widths as follows:

Roadway	Minimum Clear Width
I-485	20 feet
All other roadways, including ramps and loops	18 feet

13. The Design-Build Team shall utilize Changeable Message Signs (CMS) as follows:
- As part of the I-485 widening project, the Design-Build Team shall provide and operate a minimum of two (2) CMSs per direction on I-485 to display pertinent traffic information relevant to work zone conditions. These CMSs shall be in

addition to any other devices provided by the Department and operated by the Traffic Management Center (TMC). The Design-Build Team shall coordinate with the TMC if and when alternate route information needs to be displayed.

- All CMSs shall have the functionality to be controlled remotely by the TMC and operated in the field by the Design-Build Team.
 - Alternate routes, CMS locations and CMS messages shall be reviewed and approved by the Department and coordinated with the TMC prior to incorporation.
 - Within the I-485 widening project limits, the Design-Build Team shall provide and operate a minimum of one CMS per direction on US 521, NC 51, South Boulevard / Pineville Road, and both on-ramps from I-77 to I-485 eastbound that provides general construction activity information about the construction activities. These CMSs shall be in addition to any other CMSs required by the 2012 Roadway Standard Drawings.
 - The Design-Build Team shall show approximate CMS locations, along with the respective messages that have been coordinated with the TMC, in the Traffic Control Plans.
14. On all roadways, the Design-Build Team shall make all modifications to existing pavement markings, markers and / or signing located outside the project limits that are necessitated by the Traffic Management Plans.
15. The Design-Build Team shall provide a smooth pavement surface for traffic at all times. The Design-Build Team shall not place traffic on lanes containing rumble strips.

B. Traffic Management Plan Requirements

The Design-Build Team shall select a Private Engineering Firm (PEF) that has experience designing and sealing Traffic Management Plans for the North Carolina Department of Transportation (NCDOT) on comparable projects. The Design-Build Team shall list projects in the Technical Proposal, including description and similarity to the subject project, that the PEF developed Traffic Management Plans.

The Design-Build Team shall develop Traffic Management Plans that maintain all types of traffic (motorists, bicyclists, greenways, and pedestrians within the highway, including persons with disabilities in accordance with the Americans with Disabilities Act of 1990 (ADA), Title II, Paragraph 35.130) as defined by the *Manual for Uniform Traffic Control Devices (MUTCD)*.

The Traffic Management Plans shall adhere to the “Design-Build Submittal Guidelines” and the “Guidelines for Preparation of Traffic Control Plans for Design-Build Projects”,

which by reference are incorporated herein and are a part of the contract. These documents are available on the Design-Build website.

The Work Zone Traffic Control web site contains useful information that may be needed for the design of the Traffic Control Plans.

<http://www.ncdot.org/doh/preconstruct/wztc/>

The Staging Concept shall meet the Contract requirements and be accepted by the Department before the first phase can be submitted. Construction shall not begin until the first phase submittal meets the contract requirements and is accepted by the Department. Construction shall not begin on subsequent phase submittals until they meet the Contract requirements and are accepted by the Department. Any changes to the Staging Concept after acceptance shall require a submittal for review prior to any future phasing submittals. All submittals shall follow the 2012 *NCDOT Roadway Standard Drawings*, *NCDOT 2012 Standard Specifications for Roads and Structures*, the *Guidelines for Preparation of Traffic Control and Pavement Marking Plans for Design-Build Projects*, *Manual for Uniform Traffic Control Devices*, and the *Design-Build Submittal Guidelines*.

II. Project Operations Requirements

The following are Time Restrictions and notes that shall be included with the Traffic Control Plans General Notes, unless noted otherwise elsewhere in this RFP:

A. Time Restrictions

1. Intermediate Contract Time #1 and #2 for Lane Narrowing, Closure, Holiday and Special Event Restrictions.

As a minimum, the Design-Build Team shall maintain existing traffic patterns and shall not close or narrow a lane during the times below. When traffic is placed into the final pattern for any roadway, that will become the minimal traffic pattern and the following time restrictions shall still apply.

Road Name (Each Direction)	Day and Time Restrictions
One Lane on I-485 (including ramps / loops), One Lane on US 521 and / or One Lane on NC 51	Monday through Sunday 6:00 a.m. to 9:00 p.m.
Two Lanes on I-485 (including ramps / loops), Two Lanes on US 521 and/or Two lanes on NC 51	Monday through Sunday 6:00 a.m. to 11:00 p.m.
East Westinghouse Boulevard	Monday through Friday 6:00 a.m. to 9:00 a.m. and 4:00 p.m. to 7:00 p.m.

The Design-Build Team shall not install, reset, and / or remove any traffic control device during the times listed above, or during the event restrictions listed above.

In addition to the lane narrowing and closure restrictions stated above for all roads, during holidays, holiday weekends, special events, or any other time when traffic is unusually heavy on the roadways listed herein (excluding East Westinghouse Boulevard) or as directed by the Engineer, the Design-Build Team shall not close or narrow a lane of traffic, detain the traffic flow or alter the traffic flow on the aforementioned facilities (excluding East Westinghouse Boulevard). As a minimum, these requirements / restrictions apply to the following schedules:

- (a) For New Year's between the hours of 6:00 a.m. December 31st to 9:00 p.m. January 3rd. If New Year's Day is on a Friday, Saturday, Sunday or Monday then until 9:00 p.m. the following Tuesday.
- (b) For Easter, between the hours of 6:00 a.m. the Friday before Easter and 9:00 p.m. the Tuesday after Easter.
- (c) For Memorial Day, between the hours of 6:00 a.m. the Friday before Memorial Day to 9:00 p.m. the Wednesday after Memorial Day.
- (d) For Independence Day, between the hours of 6:00 a.m. July 3rd and 9:00 p.m. July 6th. If Independence Day is on a Friday, Saturday or Sunday, between the hours of 6:00 a.m. the Thursday before Independence Day and 9:00 p.m. the Tuesday after Independence Day.
- (e) For Labor Day, between the hours of 6:00 a.m. the Friday before Labor Day to 9:00 p.m. the Wednesday after Labor Day.
- (f) For Thanksgiving, between the hours of 6:00 a.m. the Tuesday before Thanksgiving to 9:00 p.m. the Tuesday of the following week.
- (g) For Christmas, between the hours of 6:00 a.m. the Friday before the week of Christmas Day and 9:00 p.m. the following Tuesday after the week of Christmas Day.
- (h) For any NASCAR event at the Charlotte Motor Speedway, between the hours of 6:00 a.m. the Wednesday before the 1st track event until 9:00 p.m. the day after the last track event.
- (i) For any Carolina Panthers game played in Charlotte, from five (5) hours before the game to five (5) hours after the game.
- (j) For the Democratic National Convention, from August 27, 2012 to September 7, 2012.

Liquidated Damages for Intermediate Contract Time #1 for the above lane narrowing, lane closure, holiday and special event time restrictions for I-485, I-485 ramps / loops, US 521 and NC 51 are \$2,500 per 15-minute period or any portion thereof.

Liquidated Damages for Intermediate Contract Time #2 for the above lane narrowing, lane closure, holiday and special event time restrictions for East Westinghouse Boulevard are \$1,500 per 15-minute period or any portion thereof.

2. Intermediate Contract Time #3 and #4 for Road Closure Restrictions for Construction Operations.

As a minimum, the Design-Build Team shall maintain the existing traffic pattern for all roadways and follow the road closure restrictions listed below. When a road closure is used, the Design-Build Team shall reopen the travel lanes by the end of the road closure duration to allow the traffic queue to deplete before re-closing the roadway.

The Design-Build Team shall not close any direction of travel for the following roads during the times noted below. Closure of these roads or any ramps / loops shall only be allowed for the operations listed in this intermediate contract time restriction. Using a median cross-over, exclusively for the operations listed below, shall be defined as a closure of a direction of travel.

A cross-over providing one (1) lane in each direction on I-485 will be allowed for the purpose of bridge demolition and girder installation and / or removal during the times set forth below. The Design-Build Team shall monitor the traffic queue during operation of the crossover. Should the traffic queue extend to the advance warning signs, traffic shall be returned to the existing number of lanes in each direction until the traffic queue is depleted.

Road Name	Time Restrictions
I-485 and all ramps / loops, US 521 and NC 51	Monday through Sunday 5:00 a.m. to 12:00 a.m. (midnight)
East Westinghouse Boulevard	Monday through Friday 6:00 a.m. to 9:00 p.m. Saturday and Sunday 9:00 a.m. to 9:00 p.m.

Maximum road closure duration of 30 **minutes** shall be allowed for the roadways listed in this ICT for the following operations:

- Traffic shifts to complete tie-in work and placement of pavement markings and markers.
- Installation of overhead sign assemblies and / or work on existing overhead sign assemblies over travel lanes.
- Bridge demolition and girder installation and / or removal.

Road closure with an off-site detour will be allowed for NC 51 and East Westinghouse Boulevard bridge construction (bridge demolition and girder installation and/or removal).

Up to three (3) road closures, accompanied with an off-site detour, will be allowed for NC 51 and East Westinghouse Boulevard for bridge demolition and girder installation and /or removal during the Time Restrictions listed above. The Design-Build Team shall coordinate the road closures with the Division who has final approval of the road and times selected.

Proposed road closures for any road within the project limits shall be approved by the Engineer prior to incorporation in the Traffic Management Plans.

Liquidated Damages for Intermediate Contract Time #3 for the above road closure time restrictions for I-485, I-485 ramps / loops, US 521 and NC 51 are \$5,000.00 per 15-minute period or any portion thereof.

Liquidated Damages for Intermediate Contract Time #4 for the above road closure time restrictions for East Westinghouse Boulevard are \$2,500.00 per 15-minute period or any portion thereof.

Hauling Restrictions

The Design-Build Team shall adhere to the hauling restrictions noted in the NCDOT 2012 *Standard Specifications for Roads and Structures*.

The Design-Build Team shall conduct all hauling operations as follows:

- The Design-Build Team shall not conduct any hauling operations against the flow of traffic of an open travelway unless an approved temporary traffic barrier or guardrail separates the traffic from the hauling operation.
- The Design-Build Team shall not haul during the holiday and special events time restrictions listed in Intermediate Contract Time #1 and #2, unless the hauling operation occurs completely behind temporary traffic barrier or guardrail and does not impact traffic operations.

- All entrances and exits for hauling to and from the work zone shall conform to the 2012 Roadway Standard Drawings. All hauling entrances, exits and crossings shall be shown on the Transportation Management Plan.
- Haul vehicles shall not enter and / or exit an open travel lane at speeds more than 10 mph below the posted speed limit.
- Hauling access to the I-485 median will be allowed at the beginning and end of the project. Additional hauling access points to the I-485 median shall be at locations chosen by the Design-Build Team. The Design Build Team shall coordinate the selection of the hauling access points with the Division who has final approval of the locations selected.
- Hauling operations that perpendicularly cross a roadway shall require Traffic Control and are subject to the time restrictions, and holiday, holiday weekend and special event time restrictions listed in ICT #1 and # 2.
- Single vehicle hauling and multi-vehicle hauling shall not be allowed ingress and egress from any open travel lane during the following time restrictions. The following hauling time restrictions apply only where egress and / or ingress occur between the work area and any travel lane of the roads noted below. Hauling operations that are conducted entirely behind a temporary traffic barrier or guardrail are allowed at all times and excluded from the following time restrictions:

For Single Vehicle Hauling

Road Name	Day and Time Restrictions
I-485, I-485 ramps / loops and US 521	Monday through Friday 7:00 a.m. to 9:00 a.m. 4:00 p.m. to 6:00 p.m.

For Multi-Vehicle Hauling

Road Name	Day and Time Restrictions
I-485, I-485 ramps / loops and US 521	Monday through Friday 7:00 a.m. to 9:00 a.m. 4:00 p.m. to 6:00 p.m.
East Westinghouse Boulevard and NC 51	Monday through Friday 7:00 a.m. to 9:00 a.m. 4:00 p.m. to 6:00 p.m.

The Design-Build Team shall address how hauling will be conducted in the Technical Proposal, including but not limited to, hauling of materials to and from the site and hauling of materials within NCDOT right of way.

B. Lane and Shoulder Closure Requirements

The Design-Build Team shall not install more than two (2) miles of lane closures in any one direction on any roadway within the project limits or in conjunction with this project, measured from the beginning of the merge taper to the end of the lane closure.

On multilane facilities, the Design-Build Team shall not install more than two simultaneous lane closures in any one direction. Provide a minimum of two (2) miles between lane closures, measured from the end of one closure to the first sign of the next lane closure.

The Design-Build Team shall not install more than one lane closure, in either direction on a two-lane, two-way undivided facility.

The Design-Build Team shall remove lane closure devices from the lane when work is not being performed behind the lane closure or when a lane closure is no longer needed.

When barrier is placed on the roadway shoulder, the Design-Build Team shall install shoulder closure signs and devised using NCDOT 2012 Roadway Standard Drawing No. 1101.04 in advance of the barrier.

When personnel and / or equipment are working within 15 feet of an open travel lane, the Design-Build Team shall close the nearest open shoulder using NCDOT 2012 Roadway Standard Drawing No. 1101.04, unless the work area is protected by an approved temporary traffic barrier or guardrail.

When personnel and / or equipment are working on the shoulder adjacent to an undivided facility and within 5 feet of an open travel lane, the Design-Build Team shall close the nearest open travel lane using NCDOT 2012 Roadway Standard Drawing No. 1101.02, unless the work area is protected by an approved temporary traffic barrier or guardrail.

When personnel and / or equipment are working on the shoulder adjacent to a divided facility and within 10 feet of an open travel lane, the Design-Build Team shall close the nearest open travel lane using NCDOT 2012 Roadway Standard Drawing No. 1101.02, unless the work area is protected by an approved temporary traffic barrier or guardrail.

When personnel and / or equipment are working within a lane of travel of an undivided or divided facility, the Design-Build Team shall close the lane using the appropriate roadway standard drawing from the NCDOT 2012 Roadway Standard Drawings. The Design-Build Team shall conduct the work so that all personnel and / or equipment remain within the closed travel lane.

The Design-Build Team shall not perform work involving heavy equipment within 15 feet of the edge of travelway when work is being performed behind a lane closure on the opposite side of the travelway.

C. Pavement Edge Drop off Requirements

Within the project widening limits, the Design-Build Team shall backfill at a 6:1 slope up to the edge and elevation of the existing pavement and / or use proper traffic control setup to protect traffic from the drop off as follows:

- Elevation differences that exceed 2 inches on roadways with posted speed limits of 45 mph or greater and a paved shoulder four-foot wide or less.
- Elevation differences greater than 3 inches on roadways with posted speed limits less than 45 mph and with a paved shoulder four-foot wide or less.
- Refer to the current *AASHTO Roadside Design Guide* for proper treatment of all other conditions.

Do not exceed a difference of 2 inches in elevation between open lanes of traffic for nominal lifts of 1.5 inches. Install advance warning “UNEVEN LANES” signs (W8-11) 1000 feet in advance and a minimum of every half mile throughout the uneven area.

D. Traffic Pattern Alterations

The Design-Build Team shall notify the Engineer in writing at least twenty-one (21) calendar days prior to any traffic pattern alteration. (Reference the Public Information Scope of Work for additional public information requirements.)

E. Signing

The Design-Build Team shall install advance work zone warning signs when work is within 100 feet from the edge of travel lane and no more than three days prior to the beginning of construction.

When no work is being conducted for a period longer than one week, the Design-Build Team shall remove or cover all advance work zone warning signs, as directed by the Engineer. Stationary work zone warning signs shall be covered with an opaque material that prevents reading of the sign at night by a driver traveling in either direction.

When portable signs not in use for periods longer than 30 minutes, the Design-Build Team shall lay the portable work zone sign flat on the ground and collapse the sign stand and lay it flat on the ground.

The Design-Build Team shall be responsible for the installation and maintenance of all detour signing. The Design-Build Team shall cover or remove all detour signs within and off the project limits when a detour is not in operation.

The Design-Build Team shall ensure proper signing (including but not limited to guide signs) are in place at all times during construction, as required by the *MUTCD*. All temporary signing shall be shown on the Traffic Control Plans or a Temporary Signing Plan to be reviewed and accepted by the Department prior to incorporation.

F. Traffic Barrier

The Design-Build Team shall use only an NCDOT approved temporary traffic barrier system and adhere to the following requirements:

- Install temporary traffic barrier system a maximum of two (2) weeks prior to beginning work in any location. Once the temporary traffic barrier system is installed at any location, proceed in a continuous manner to complete the proposed work in that location.
- Place all temporary barrier used for traffic control directly on an asphalt or concrete surface.
- Once the temporary traffic barrier system is installed and no work has been or will be performed behind the temporary traffic barrier system for a period longer than two (2) months, remove/reset the temporary traffic barrier system unless the barrier is protecting traffic from a hazard.
- Protect the approach end of temporary traffic barrier system at all times during the installation and removal of the barrier by either a truck mounted impact attenuator (maximum 72 hours) or a temporary crash cushion.
- Protect the approach end of temporary traffic barrier system from oncoming traffic at all times by a temporary crash cushion unless the approach end of temporary traffic barrier system is offset from oncoming traffic as follows:

Posted speed limit (MPH)	Minimum offset (feet)
40 or less	15
45 – 50	20
55	25
60 mph or higher	30

- Install temporary traffic barrier system with the traffic flow, beginning with the upstream side of traffic. Remove the temporary traffic barrier system against the traffic flow, beginning with the downstream side of traffic.

- Install drums to close or keep closed tangent sections of the roadway until the temporary traffic barrier system can be placed or after the temporary barrier system has been removed. The distance, in feet, between drums shall be no greater than twice the posted speed limit (MPH).
- The Design-Build Team shall minimize the presence of portable concrete barrier along acceleration ramps / loops. At acceleration ramps / loops, the Design-build Team shall install temporary traffic barrier system in a manner that provides a minimum of 200 feet from the end of the pavement marking taper to the beginning of the barrier taper.
- The Design-Build Team shall be responsible for providing proper connection between the existing bridge rail and the temporary barrier system and include this information in the appropriate plans.

G. Traffic Control Devices

The Design-Build Team shall use traffic control devices that conform to all NCDOT requirements and are listed on the NCDOT's Approved Products List. The Approved Products List is shown on NCDOT's Work Zone Traffic Control website. The use of any devices that are not shown on the Approved Product List shall require written approval from the Department prior to incorporation.

Channelizing device spacing shall not exceed a distance in feet equal to twice the posted speed limit. Channelization devices shall be spaced 10 feet on-center in radii. Channelization devices shall be located 3 feet off the edge of an open travelway, when lane closures are not in effect. Skinny drums shall only be allowed as defined in Section 1180 of the 2012 *NCDOT Standard Specifications for Roads and Structures*.

Place Type III barricades, with "ROAD CLOSED" signs (R11-2) attached, of sufficient length to close entire roadway. Stagger or overlap barricades to allow for ingress or egress.

When a CMS is placed within the clear zone, provide proper delineation and protection for the traveling public.

Place sets of three drums perpendicular to the edge of the travelway on 500-foot centers when unopened lanes are closed to traffic. These drums shall be in addition to channelizing devices.

H. Temporary Pavement Markings, Markers and Delineation

The Design-Build Team shall show temporary pavement markings on the Traffic Control Plans that meet the requirements of the RFP and the *Guidelines for Preparation of Traffic Control and Pavement Marking Plans for Design-Build Projects*.

The Design-Build Team shall use pavement marking and marker products that conform to all NCDOT requirements and are listed on the NCDOT's Approved Products List. The use of any devices that are not shown on the Approved Product List shall require approval from the Department prior to incorporation.

The Design-Build Team shall install pavement markings and markers in accordance with the NCDOT 2012 *Standard Specifications for Roads and Structures*, and in accordance with the manufacturer's procedures and specifications.

The Design-Build Team shall install temporary pavement markings that are the same width as existing on all roadways.

On all roadways, the Design-Build Team shall install temporary pavement markings that are the same width as existing pavement markings. For roadways that do not have existing pavement markings, the Design-Build Team shall install pavement markings that are the same width required for the final movement markings in the Pavement Marking Scope of Work found elsewhere in this RFP

The Design-Build Team shall install temporary pavement markings and temporary pavement markers on the interim surface or temporary pattern as follows:

Road	Marking	Marker
All Roads and Existing Structures	Minimum of Paint	Raised Temporary
Proposed Structures	Cold Applied Plastic (Type IV)	Raised Temporary

The Design-Build Team may use any type of pavement markings on the NCDOT Approved Products List for temporary pattern. However, the Design-Build Team shall maintain a minimum retroreflectivity for pavement marking on all roads (existing and temporary) at all times during construction, as follows:

White:	125 mcd / lux / m ²
Yellow:	100 mcd / lux / m ²

When using Cold Applied Plastic (Type IV) pavement markings, place temporary raised markers half on and half off edge lines and centerlines to help secure the tape to the roadway. Markers shall match the color of the pavement markings they are supplementing and spaced the appropriate distance apart in accordance with the NCDOT 2012 Roadway Standard Drawing No. 1250.01, sheet 1 of 3.

Prior to opening a roadway to traffic on facilities that the installation of a proposed monolithic island has not occurred, outline the location of the proposed monolithic island

with the proper color pavement marking and delineate the proposed monolithic island with drums.

Tie proposed pavement marking lines to existing pavement marking lines.

Remove / replace any conflicting / damaged pavement markings and markers by the end of each day's operation.

The Design-Build Team shall not place temporary markings, other than Cold Applied Plastic Type 4 – Removable Tape, on any final asphalt pavement surface unless the temporary markings are placed in the exact location of the final pavement marking.

The Design-Build Team shall remove all conflicting markings or markers prior to shifting traffic to a new pattern.

Unless noted otherwise elsewhere in this RFP, removal of temporary pavement markings on asphalt surfaces shall be accomplished by an NCDOT approved system to minimize damage to the road surface. All temporary pavement markings on concrete pavement shall be removed by water blasting. Temporary pavement markings shall not be obliterated with any type of Black Pavement Markings (paint or other material). The Design-Build Team shall remove 100% of all temporary pavement markings without removing more than 1/32-inch of the pavement surface.

I. Temporary Signals

Use the following notes if the Design-Build Team recommends using temporary signals for maintenance of traffic.

- Notify the Engineer in writing a minimum of two months before a traffic signal installation by others is required.
- Shift and revise all signal heads as shown on the accepted Signal Plans developed by the Design-Build Team.

J. Miscellaneous

Provide portable temporary lighting to conduct night work in accordance with the NCDOT 2012 *Standard Specifications for Roads and Structures*.

Provide proper drainage for all temporary alignments and / or traffic shifts.

Law enforcement officers may be used to maintain traffic through the work area and or intersections. The Design-Build Team shall be responsible for coordinating with the law enforcement agency for the use of law enforcement officers. The Design-Build Team shall only utilize Officers who are outfitted with law enforcement uniforms and marked vehicles, which are equipped with proper lights mounted on top of the vehicle and agency emblems. The Design-Build Team shall address where and why law enforcement officers will be used in the Technical Proposal

The Design-Build Team shall install No Parking / Tow Away Zone 1000 feet in advance of the *Begin Road Work* signs, on all on-ramps within the project limits, and a minimum of every 3000 feet in each direction of I-485.

The Department will obtain a speed reduction ordinance when workers and / or lane closures are present on I-485.

The Department may grant a \$250 Speeding Penalty Ordinance provided the project meets or exceeds the required criteria. If the Traffic Management Plans cannot be designed to eliminate the need for a Speeding Penalty Ordinance and meet the criteria listed in the NCDOT Work Zone Traffic Control Guidelines, the Design-Build Team shall prepare an engineering study. The Design-Build Team shall submit a formal Speeding Penalty Ordinance request to the Transportation Program Management Director that states why the ordinance is needed and why the Traffic Management Plans cannot be designed to avoid the need. Upon receipt of the formal request, the Design-Build Team shall allow six weeks for the Speeding Penalty Ordinance to be approved. The Design-Build Team shall identify the need for a Speeding Penalty Ordinance in the Technical Proposal.

The Design-Build Team shall be responsible for all required temporary shoring, including but not limited to providing, installing, maintaining and removing. Temporary shoring for the maintenance of traffic is defined as shoring necessary to provide lateral support to the side of an excavation or embankment parallel to an open travelway when a theoretical 2:1 (H:V) slope from the bottom of the excavation or embankment intersects the existing ground line closer than 5 feet from the edge of pavement of the open travelway. The Design-Build Team shall identify locations where temporary shoring for maintenance of traffic will be required on the Traffic Control Staging Concept. The Design-Build Team shall install temporary traffic barrier as shown on a detail available from Work Zone Traffic Control that provides design information on the temporary traffic barrier location in relation to the temporary shoring and traffic location. The NCDOT Geotechnical Engineering Unit and Work Zone Traffic Control websites have more information on temporary shoring. (Notes related to Temporary Shoring are not required in the General Notes sheet for the Traffic Control Plans.)

The Design-Build Team shall adhere to the additional shoring requirements located on Work Zone Traffic Control and Geotechnical Engineering Unit websites:

<http://www.ncdot.org/doh/preconstruct/highway/geotech/formdet/standards.html>

<http://www.ncdot.org/doh/preconstruct/wztc/DesRes/English/TemporaryShoring/TempShoring.pdf>

The Design-Build Team shall identify on the appropriate traffic control detail where temporary shoring will be used by providing station limits, offsets, the type of shoring and where temporary traffic barrier will be located if needed.

The Design-Build Team shall coordinate with the Charlotte Area Transit System (CATS) for all traffic control phasing that will affect existing transit stops or transit routes.

K. Traffic Control Supervisor

The Design-Build Team shall furnish a Traffic Control Supervisor for the project who is knowledgeable of Traffic Control Plan design, devices and application, and has full authority to ensure traffic is maintained in accordance with the plans and specifications.

The Traffic Control Supervisor shall be on the project site overseeing all road closures and median crossover operations to ensure traffic control devices are properly installed and adjusted as necessary. The Traffic Control Supervisor shall also make necessary changes to the traffic control operations and aide in the monitoring of traffic queuing.

The Design-Build Team shall identify a Traffic Control Supervisor in their Technical Proposal that has the following qualifications:

- (1) A minimum 24 months of On-the-Job Training in supervision and work zone set up and implementation on similar projects.
- (2) Be certified by responsible party (contractor or NCDOT) to have the required experience and training and is qualified to perform the duties of this position. If certified by the Contractor, a notarized certification letter shall be furnished to the Engineer at the preconstruction meeting. The letter shall state the Traffic Control Supervisor is qualified, and state that the Traffic Control Supervisor has the authority to ensure traffic is maintained in accordance with the contract documents.

The Traffic Control Supervisor for the project shall be capable of performing the following:

- (1) Be available and on call at all times to direct/make any necessary changes in the traffic control operations in a timely and safe manner.
- (2) Coordinate and cooperate with traffic control supervisors of adjacent, and overlapping construction projects, as well as construction projects in proximity to the subject project, to ensure safe and adequate traffic control setup is maintained throughout the project at all times, including periods of construction inactivity.
- (3) Coordinate and cooperate with NCDOT Traffic Management Center personnel in Mecklenburg County to ensure proper messages are displayed on the CMSs and DMSs.
- (4) Provide traffic control setup that ensures safe traffic operations and workers' safety throughout the construction area.

- (5) Attend all scheduled traffic control coordination meetings, as required by the Engineer.
- (6) Monitor traffic delays and backups within the work zone.

SIGNING SCOPE OF WORK (10-21 -11)**General**

The Signing Plans shall be prepared by the Design-Build Team in accordance with the *Manual on Uniform Traffic Control Devices (MUTCD)* effective on the Technical Proposal submittal date, *the 2004 NC Supplement to the MUTCD, NCDOT Standard Specifications for Roads and Structures* (January 2012), the NCDOT Roadway Standard Drawings (January 2012) for the design and development of signing plans, the latest Standard Specifications for *Structural Supports for Highway Signs, Luminaires, and Traffic Signals* published by AASHTO, “*Guidelines for Preparation of Signing Plans for Design-Build Projects*”, the “*Design-Build Submittal Guidelines*” and the contract requirements contained herein.

Signing Plan Requirement

The Design-Build Team shall select a Private Engineering Firm (PEF) that has experience in designing and sealing Signing Plans for NCDOT on projects comparable to this project. The Technical Proposal shall list projects, where Signing Plans were developed by the PEF, including description and similarity to the subject project.

Signs Furnished by Design-Build Team

The signs shall be furnished by the Design-Build Team according to the specifications provided by the NCDOT.

Signing Project Limits

The Design-Build Team shall be responsible for the design, fabrication and installation of all signs required through the construction limits of the mainline and all -Y- Lines. The Design-Build Team shall also be responsible for the design, fabrication and installation of all signs required beyond the construction limits of the mainline and all -Y- Lines to ensure adequate advance signage and spacing is provided.

The posted speed limit for this facility shall be 65 mph.

Sign Design

The Design-Build Team shall be responsible for the design, fabrication and installation of all signs required for the mainline, as well as all -Y- Lines. The Design-Build Team shall be responsible for all Type A, B, and D sign designs, fabrication and installation for ground mounted signs. The Design-Build Team shall be responsible for sizing, fabricating, locating and installing all Type E (warning and regulatory signs), Type F signs (route marker assemblies) and milemarkers.

The Design-Build Team shall design, fabricate and install mile markers every **0.2** mile on the project. Each milemarker location shall have two milemarkers, mounted back to back on one U-post, on the median for each direction of travel on the mainline. The milemarker designs shall be

in accordance with the Intermediate Enhanced Reference Location Signs (D10-5) referenced in the *Standard Highway Signs* (2004 Edition).

All sign designs shall be included in the Signing Plans. All sign designs shall be prepared using the latest version of GuidSign software. Refer to the Signing and Delineation Unit's main website below located under Private Engineering Firm by clicking on Seed Files (guidsign_english.dgn or guidsign_metric.dgn) for the latest GuidSign updates:

<http://www.ncdot.org/doh/preconstruct/traffic/congestion/SIGN/default.html>

Logo Signs

The Design-Build Team is not responsible for designing, locating, or installing any new Logo signs (blue service signs with specific business panels included on signs); however, the Design-Build Team shall be responsible for relocating existing Logo signs upon completion of the widening, realignment, or other construction procedures.

Sign Maintenance

The Design-Build Team shall maintain all existing signs during construction, including temporary installations of Guide and Logo Signs on supports to ensure signs are properly maintained and visible during project construction. The Design-Build Team shall be responsible for designing and installing temporary sign supports. If damage occurs to the Logo Signs or the business panels during construction or installation, notify the Division Logo Coordinator as soon as possible. The Design-Build Team shall be responsible for replacement of Logo Signs or Logo business panels should damage occurs. If the Logo Signs are removed and disposed of per the RFC signing plans, the business panels on the signs shall be removed and returned to the Division Logo Coordinator. The order of preference for Logo Signs shall be maintained during project construction (see MUTCD section 2J.01).

Temporary Signs

The Design-Build Team shall be responsible for designing, fabricating, and installing temporary signs and supports. Reference the Signing Section of the Traffic Management Scope of Work found elsewhere in this RFP for additional temporary signing requirements.

Sign Locations

The Design-Build Team shall be responsible for determining the station locations for all signs. To avoid sign placement in locations where their usefulness will be short-lived, the Design-Build Team shall coordinate the proposed sign designs and locations with existing and future projects through the Department.

Ground Mounted Supports

Unless otherwise approved by the Engineer, ground mounted signs on a freeway or expressway, with breakaway or yielding supports, shall be located a minimum of 30 feet from the edge of the outside travel lane to the nearest edge of the sign.

NCDOT will provide the software for ground mounted sign support designs. The Design-Build Team is responsible for all design, fabrication, and installation of ground mounted supports and signs. Instructions for loading support design software will be made available upon request.

Exit gore signs shall be erected on omni-directional breakaway supports.

Overhead Sign Assemblies

The Design-Build Team shall be responsible for the design, fabrication and installation of overhead sign assemblies that meet all Department requirements. The wind speed for the overhead sign assembly designs shall be 90 mph. The Design-Build Team shall be responsible for calculating the windload area for the overhead sign assembly. The windload area shall be flush with the sign height and width. When calculating the windload area, the Design-Build Team shall include exit panels as part of the sign height. The coordination with future projects and sign messages shall be considered when designing and fabricating overhead sign assemblies.

The minimum vertical clearance beneath all overhead sign assemblies shall be 17 feet.

Prior to modifying existing overhead sign assemblies within the project limits to accommodate proposed signs, the Design-Build Team shall perform a structural analysis on the overhead sign structures in accordance with the latest version of the latest *AASHTO Standard Specifications for Structural Supports for Highway Signs, Luminaires, and Traffic Signals*. The Design-Build Team shall obtain Department acceptance of the structural analysis prior to construction. The Design-Build Team shall replace all existing overhead sign assemblies determined to be structurally inadequate for the proposed modifications.

The Design-Build Team shall prepare shop drawings for all modified overhead sign structures for NCDOT review and acceptance. (Reference *Guidelines for Preparation of Signing Plans for Design-Build Projects* and *2012 Standard Specifications for Roads and Structures* for additional requirements, including but not limited to shop drawing design and submittals requirements.

The Design-Build Team shall design, fabricate, and install overhead sign supports and foundations in accordance with the Project Special Provisions for Foundations and Anchor Rod Assemblies for Metal Poles, Overhead and Dynamic Message Sign Foundations, and Overhead Sign Supports found elsewhere in this RFP.

Lighting will not be required on overhead sign assemblies.

The Design-Build Team shall be responsible for determining if existing full span overhead sign structures on I-485 will need to be replaced due to widening to the median. If minimum offsets

cannot be obtained, the Design-Build Team shall be responsible for design, fabrication and installation of new overhead sign assemblies.

At a minimum, the Design-Build Team shall provide the following I-485 eastbound Overhead Sign Assemblies:

- NC 51 – One Advance Exit Only Guide Sign
- NC 51 Exit 64A – Exit Directional
- US 521 – Two Advance Guide Signs

At a minimum, the Design-Build Team shall provide the following I-485 westbound Overhead Sign Assembly:

- NC 51 – Two Advance Exit Only Guide Signs

At a minimum the Design-Build Team shall provide the following northbound US 521 Overhead Sign Assembly:

- Ramp D Full-Span Exit Directional

Overhead Sign Supports for Freeway Facilities

Overhead sign supports shall be located a minimum of 40 feet from the edge of the outside travel lane to the center of the sign supports. If the minimum 40-foot distances cannot be obtained, the overhead sign supports shall be located a minimum of 22 feet from the outside travel lane and protected by guardrail or other NCDOT approved positive protection barrier.

The Design-Build Team shall provide the appropriate positive protection and drainage for all overhead sign median supports.

Overhead Sign Sheeting

The Design-Build Team shall design and fabricate overhead signs using Grade A on C retroreflective sheeting for the legends (text) and border.

The Design-Build Team shall remove and dispose of signs and lighting systems on existing overhead sign assemblies and design fabricate and install proposed overhead signs using Grade A on C retroreflective sheeting for the legends (text) and border. Refer to the Signing and Delineation Unit's main website listed below under Resource titled 'Standard Practice for Retroreflectivity Sign Sheeting':

<http://www.ncdot.org/doh/preconstruct/traffic/congestion/SIGN/default.html>

Guardrail or Other Protection for Signs and Overhead Assemblies

The Design-Build Team shall be responsible for determining, designing and installing any protection for proposed and existing sign supports.

Signing Roadway Standards, Typical Sheets and Specifications

Signing roadway standards and typical sheets to be used in summarizing quantities, standard specifications, and compiling Type E and F signs are located on the Signing and Delineation Unit's main website listed below under Private Engineering Firm by clicking on Seed Files (Engseed.dgn) for the latest standards, typical sheets and specifications:

<http://www.ncdot.org/doh/preconstruct/traffic/congestion/SIGN/default.html>

The Design-Build Team shall incorporate the appropriate information onto these sheets and submit them to the Transportation Program Management Director and the Signing and Delineation Unit for review and acceptance.

Removal and Disposal of Existing Signs

The Design-Build Team shall be responsible for determining those existing signs that will no longer be needed upon completion of the project, such as on -Y- lines and project tie-ins. The Design-Build Team shall be responsible for removal and disposal of these signs and supports. The Design-Build Team shall show and note these signs on the signing plan view sheets.

Construction Revisions

After submittal of RFC Signing Plans, all construction revision shall be submitted to NCDOT for review and acceptance prior to incorporation.

ITS CONDUIT SYSTEM SCOPE OF WORK (10-24-11)**GENERAL**

The Design-Build Team shall install an underground conduit system including four (4) 1.25-inch conduits, two (2) 2-inch lateral conduits, oversized heavy-duty junction boxes, and delineator markers from the existing conduit system and junction box located along eastbound I-485 at the South Boulevard interchange to the proposed future Dynamic Message Sign to be installed by others approximately 1.5 miles south of US 521 (Johnston Road). Fiber optic cable, ITS devices, and electrical/ communication / data services to the ITS devices are not included in this contract and will be installed by others. The Design-Build Team shall be responsible for determining the conduit system routing and location of the junction boxes, obtaining Engineer's approval of the locations, installing the conduits, junction boxes, delineator markers and implementing test procedures.

Prior to any underground work, locate existing utilities, communications cable, power cable, and adjust work activities to protect these facilities. Immediately cease work and notify the Engineer and the affected owners if damage to existing utilities occurs. Repair damages to existing utilities, communications cable, and / or power cable at no cost to the Department.

DESIGN REQUIREMENTS**Conduit System**

The conduit system installation must be in compliance with the approved *Communication Cable Conduit Routing* Plans developed by the Design-Build Team. The Design-Build Team shall design the conduit system to avoid conflicts with future widening, drainage facilities, guardrail, sign structures / foundations, and future DMS signs. The conduit system shall be designed so that it is not necessary to close a lane or shoulder in order to access the junction boxes. The conduit system shall not be located in the median of I-485.

Design the mainline conduit system (four 1.25-inch conduits) to be installed as described in this Scope of Work along I-485. Install lateral conduits (two 2-inch conduits) across the roadway at each future ITS device on the opposite side of the roadway and at each interchange for connecting future ITS devices. The lateral conduits shall intercept the mainline conduit in an oversized heavy-duty junction box.

Oversized heavy-duty junction boxes shall be located at 1500 feet spacing and (1) every interchange; (2) the intersection of every lateral conduit (serving future ITS devices as indicated below; and (3); both ends of directional drill segments and (4); the beginning and end of the project.

Install conduit plugs, pull line and tracer wire in accordance with Subarticle 1098-4 (C) of the NCDOT 2012 *Standard Specifications for Roads and Structures*.

ITS Devices

The Design-Build Team shall develop *Communication Cable Conduit Routing* plans based on the following future ITS Device locations:

- One CCTV Camera south / east of exit 67
- One CCTV Camera near Nations Ford Road
- One CCTV Camera near East Westinghouse Boulevard
- One CCTV Camera near Royshall Drive
- One CCTV Camera at exit 65
- Two CCTV Cameras at exit 64
- One CCTV Camera near Carmel Road
- One CCTV Camera at exit 61
- One Dynamic Message Sign on I-485 westbound approximately 1.5 miles east of US 521

ELECTRICAL SERVICE

The Design-Build Team shall coordinate with the local electric utility company(s) to plan for future service drops at the proposed ITS device locations. The Design-Build Team shall determine locations for the utility company to install primary to secondary voltage transformers. ITS devices require 200 Amps, 240 / 120 VAC service drops.

SPECIFICATIONS

Perform all work in accordance with the NCDOT 2012 *Standard Specifications for Roads and Structures* and the NCDOT 2012 *Roadway Standard Drawings*.

Other Codes and Standards

All communication conduit system materials shall conform to the latest version of the applicable standards of the National Electrical Code (NEC), National Electric Manufacturer's Association (NEMA), the Underwriters' Laboratories, Inc. (UL), the Electronic Industries Association (EIA), the International Municipal Signal Association (IMSA), and the National Electrical Safety Code (NESC). All materials and workmanship shall conform to the requirements of the NESC, standards of the American Society for Testing and Materials (ASTM), and the American National Standards Institute (ANSI). Comply with all federal laws, state laws, and city codes in accordance the NCDOT 2012 *Standard Specifications for Roads and Structures*.

SUBMITTALS

The Design-Build Team shall submit a 60% set of Preliminary Plans, 90% set of project plans, and 100% set of project plans including catalog cuts, and specifications for materials, installation and testing for review and acceptance by the NCDOT. No construction of the conduit system

shall begin until the Department has accepted the 100% plans and specifications. Provide NCDOT with a minimum of 10 working days for each review.

MATERIALS & CONSTRUCTION

Furnish and install new materials and hardware that meet the requirements of the NCDOT 2012 *Standard Specifications for Roads and Structures* and this Scope of Work.

QUALIFIED PRODUCTS LIST

The Design-Build Team shall submit a listing of items on the NCDOT Qualified Products List (QPL) to receive approval for use on the project. Catalog cuts will not be required for items on the QPL. The QPL web site is:

<http://www.ncdot.org/doh/preconstruct/traffic/ITSS/SMS/qpl/>

MAINTENANCE AND REPAIR REQUIREMENTS

Maintain and repair the communication network conduit system until the final acceptance of the project by the NCDOT. The Design-Build Team shall be responsible for repairing any damage caused to the system by the Design-Build Team or due to faulty materials or workmanship in accordance with the NCDOT 2012 *Standard Specifications for Roads and Structure*.

DOCUMENTATION

Upon completion of the conduit system installation, the Design-Build Team shall furnish the Engineer with Plans of Record Drawings with GPS coordinates, horizontal distances from the roadway, and vertical depth of all conduits. Plan of Record Drawings shall be provided for all conduits and junction boxes installed as part of this Scope of Work.

TESTING

Upon conclusion of all roadway construction activities, the Design-Build Team shall perform a mandrel test in the presence of the Engineer on all conduits to ensure no conduit(s) has been damaged. Furnish a non-metallic mandrel having a diameter of approximately 50% of the inside diameter of the conduit in which it is to be pulled through each conduit. If damage has occurred, replace the entire length of conduit between junction boxes.

PAVEMENT MARKINGS SCOPE OF WORK (10-21-11)**General**

The Design-Build Team shall prepare Final Pavement Marking Plans in accordance with the *Manual on Uniform Traffic Control Devices (MUTCD)* effective on the Technical Proposal submittal date, the 2012 NCDOT Roadway Standard Drawings, “*Guidelines for Preparation of Traffic Control and Pavement Marking Plans for Design-Build Projects*” the “*Design-Build Submittal Guidelines*” and the contract requirements contained herein.

Final Pavement Marking Plan Requirements

The Design-Build Team shall select a Private Engineering Firm (PEF) that has experience designing and sealing Pavement Marking Plans for NCDOT on comparable projects.

The Design-Build Team shall develop Pavement Marking Plans that maintain all types of traffic (motorists, bicyclists, and pedestrians within the highway, including persons with disabilities in accordance with the Americans with Disabilities Act of 1990 (ADA), Title II, Paragraph 35.130) as defined by the *Manual for Uniform Traffic Control Devices (MUTCD)*.

Final Pavement Marking Project Limits

The Final Pavement Marking Plans shall address any required modifications to existing pavement markings located outside the project limits to ensure appropriate tie-ins. The Design-Build Team shall be responsible for installing all pavement markings and markers located within and outside the project limits, resulting from the project construction.

Pavement Markings, Markers and Delineation

The Design-Build Team shall not place any final pavement markings and markers until the Final Pavement Marking Plans have been accepted by the Department.

The Design-Build Team shall use pavement marking and marker products that conform to all NCDOT requirements and are listed on the NCDOT’s Approved Products List. The use of any devices that are not shown on the Approved Product List shall require written approval from the NCDOT Signing and Delineation Unit.

The Design-Build Team shall install pavement markings and markers in accordance with the NCDOT 2012 *Standard Specifications for Roads and Structures*, and in accordance with the manufacturer’s procedures and specifications.

The Design-Build Team shall install pavement markings and pavement markers on the final surface as follows:

Road	Marking	Marker
-L- Line , US 521 and NC 51	Thermoplastic	Snowplowable
All other -Y- Lines	Thermoplastic	Match Existing
Concrete Bridge Decks	Cold Applied Plastic (Type II or III)	Raised

On asphalt surfaces, the Design-Build Team install place Heated-in-Place Thermoplastic or Extruded Thermoplastic markings for stop bars, symbols, characters and diagonals.

The Design-Build Team shall tie proposed pavement marking lines to existing pavement marking lines.

The Design-Build Team shall replace any pavement markings that have been damaged by the end of each day's operation.

On all Full Control of Access interstate facilities and US routes, the Design-Build Team shall install six-inch wide pavement markings, i.e., lane lines, edge lines and skips for the final pavement markings. The Design-Build Team shall install gore lines that are twice the edge line thickness.

SIGNALS SCOPE OF WORK (10-21-11)**I. TRAFFIC SIGNALS**

There are four existing traffic signals within the project limits. The Charlotte Department of Transportation will be responsible for the design, required modifications, installation and maintenance of these traffic signals. The Charlotte Department of Transportation shall remove and dispose of the existing traffic signal to be removed. However, the Design-Build Team shall coordinate with the Charlotte Department of Transportation to assist them in developing the Signal Plans. The Design-Build Team shall provide site access to the Charlotte Department of Transportation and their contractors for modifications to these traffic signals during construction and removal of the existing traffic signal. The locations of signalized intersections are listed below:

Existing Signals to be Upgraded (3)		
Signal Number	Intersection Description	Contact Information for CDOT
10-1850	US 521 (Johnston Road) at I-485 EB Ramps	Charles Abel, PE Charlotte Department of Transportation 600 East Fourth Street Charlotte, NC 28202-2858 (704) 336-3945 cabel@ci.charlotte.nc.us
10-1918	US 521 (Johnston Road) at John Delaney Drive	
10-1519	US 521 (Johnston Road) at Ballantyne Commons Parkway	
Existing Signal to be Removed (1)		
10-1851	US 521 (Johnston Road) at I-485 WB Ramps	Charles Abel, PE Charlotte Department of Transportation 600 East Fourth Street Charlotte, NC 28202-2858 (704) 336-3945 cabel@ci.charlotte.nc.us

RAILROAD COORDINATION SCOPE OF WORK (10-24-11)

The Design-Build Team shall be responsible for coordinating all Norfolk Southern Railway (NSR) design and construction details on NSR right of way. The Design-Build Team shall be responsible for all coordination required to obtain the necessary Railroad Agreements. The Design-Build Team shall be responsible for all Railroad costs associates with this project, including but not limited to insurance, flagging and construction engineering.

Preparation for Construction within the Existing NSR Right of Way

The Design-Build Team, unless otherwise provided or directed by NSR's Railroad Engineer, via the Transportation Program Management Director, shall comply with the following applicable documents:

- (A) *AREMA Manual for Railroad Engineering*, latest edition
- (B) *Norfolk Southern Corporation Special Provisions for Protection of Railway Interest*
- (C) Norfolk Southern's "*Standard Specifications for Materials and Construction, August 1997.*"
- (D) *Norfolk Southern Railway Guidelines for Design of Grade Separation Structures*
- (E) *Federal Aid Policy Guide 23 CFR 140I*
- (F) *Federal Aid Policy Guide 23 CFR 646*
- (G) *NCDOT Construction Manual Section 105-8*
- (H) *NCDOT Standard Specifications for Roads and Structures Section 107-9 (Excluding Paragraph 2)*
- (I) North Carolina Administrative Code Section T19A: 02B, 0150 through 0158

Based on information obtained from NSR, an average of one freight train a day crosses the bridge located west of South Boulevard at a maximum operating speed of 10 miles per hour; and passenger trains do not cross the aforementioned bridge. The Design-Build Team shall be responsible for verifying the number and type of trains per day and the maximum speed allowed.

Arrangements for Protection and Adjustments to Existing and Proposed Railroad Crossing Surface and Roadbeds

The Design-Build Team shall not commence any work on the Railroad right of way until all agreements have been executed, insurance acquired and approved, and all construction plans have been approved by the Railroad. The Design-Build Team shall make the necessary arrangements with the Railroad that are required to protect against property damage that may result in loss of service, expense, or loss of life. The Design-Build Team shall be responsible for all damage to the Railroad resulting from their operations and the Railroad may issue a stop order until all dangerous situations are remedied.

The Design-Build Team shall be responsible for providing Railroad Protective Liability Insurance for Bodily Injury Liability, Property Damage Liability, and Physical Damage to Property in the amount of \$2,000,000 Per Occurrence for freight rail and / or \$5,000,000 for passenger rail. The Design-Build Team shall obtain \$6,000,000 in Aggregate coverage for freight and / or \$10,000,000 for passenger, Per Annual. Said policy shall provide coverage for all loss, damage or expense arising from bodily injury and property damage liability, and physical damage to property attributed to acts or omissions at the job site. The Design-Build Team shall be responsible for verifying and obtaining the appropriate insurance and coverage with the NSR. Other insurance requirements, including those for all subcontractors, are detailed in the documents referenced herein.

The Design-Build Team shall be required to use the Standard NCDOT Agreements and Insurance Special Provisions forms, which will be supplied by the NCDOT Rail Division, State Railroad Agent upon request.

After negotiations between the Design-Build Team and the Railroad have been finalized, the Design-Build Team shall submit executed agreements and plans to NCDOT's Rail Division, State Railroad Agent, via the Transportation Program Management Director, for plan approval and final agreement execution by NCDOT, prior to authorizing railroad work. After approval by NCDOT, one copy of the executed agreement will be returned to the Design-Build Team and one copy forwarded to the NCDOT's Resident Engineer, prior to any construction work by the Design-Build Team or Railroad.

Coordination with Norfolk Southern Corporation:

The Design-Build Team shall coordinate with J. N. Carter, Jr., Chief Engineer, Bridges and Structures, Norfolk Southern Corporation, 99 Spring Street, S. W., Atlanta GA 30303-0142, (contact is Scott Overbey at telephone number 404-582-5588) to obtain plan approval and, if needed, a partially executed legal agreement with Norfolk Southern Corporation and the Department of Transportation as the parties in the agreement for proposed roadway work.

The Department will review the agreement prior to submittal to the Railroad. The Department will execute and distribute the Agreement within 14 calendar days of receipt. The agreements and any modifications thereto shall include necessary Force Account items such as preliminary engineering, construction engineering and flagging. The NSR has sole authority to determine the need for flagging required to protect its operations and property. The Department shall reimburse the NSR directly for all costs of flagging that is required on account of construction within the Railroad property shown in the Design-Build Team's plans, or that is covered by an approved plan revision, supplemental agreement or change order. The Department will be responsible for payment of the Railroad Force Account work; however, the Design-Build Team shall reimburse the Department for these costs including any Force Account estimate overruns. This reimbursement shall be incidental to the lump sum price bid for the project. Upon request, the Department will provide copies of the railroad's invoices to the Design-Build

Team for review. The Design-Build Team shall have ten (10) days to provide comments to the Department, after which the Department will pay the invoice. The Design-Build Team shall be responsible for maintaining records to verify the invoice items.

The preliminary plan submittal to the Railroad shall include roadway plans, the Railroad's "Overhead Bridge Crossing Data," appropriate roadway plan sheets showing impacts to the Railroad's right of way, erosion control plans, and drainage calculations for any drainage on or across the Railroad's right of way. An electronic version of the preliminary plans and data shall be submitted to Norfolk Southern Corporation through the NCDOT Transportation Program Management Director. If the Railroad requires RFC's and / or Final Plans, then five (5) half size sets shall be provided to the Railroad. If any re-submittals of plans or any additional information is required, five (5) half size sets shall be submitted to the Railroad. Working Drawings affecting the Railroad's operations and / or right of way shall follow submittal process as outlined in the 2012 *Standard Specifications for Roads and Structures* or Special Provisions.

UTILITIES COORDINATION SCOPE OF WORK (10-24-11)

The Design-Build Team shall obtain the services of a Private Engineering Firm (PEF) knowledgeable in the NCDOT Utility Coordination Process involved with utility relocation / installation and highway construction. The Design-Build Team shall be responsible for coordinating all utility relocations, removals, and / or adjustments where the Design-Build Team and Utility Company, with concurrence from the Department, determine that such work is essential for highway safety and performance of the required highway construction. Coordination shall be for all utilities whether or not they are specifically identified in this scope of work and shall include any necessary utility agreements when applicable. NCDOT will be the approving authority for all utility agreements and approval of plans.

Cost Responsibility

The cost responsibility for relocating any water and sewer facilities shall be as outlined below in the section entitled "Water and Sewer."

Except as noted above, The NCDOT will be responsible for all other non-betterment utility relocation cost when the utility company has prior rights of way / compensable interest. The utility company shall be responsible for the relocation costs if they can not furnish evidence of prior rights of way or a compensable interest in their facilities. The Design-Build Team shall be responsible for determining the cost responsibility for the utility relocations. The Design-Build Team shall be responsible for all costs associated with utility relocations due to haul roads and / or any other temporary conditions resulting from the Design-Build Team's methods of operation or sequence of work.

Project Details

The Design-Build Team shall be responsible for verifying the utility locations, type of facilities, and identifying the utility owners in order to coordinate the relocation of any utilities, known and unknown, in conflict with the project. The following utilities are known to be located within the project construction limits:

Utility Owner	Utility Type	Cost Responsibility
Duke Energy	Power	Utility Owner
Pineville Electric Company	Power	Utility Owner
AT&T	Telephone	Utility Owner
Time Warner	Cablevision	Utility Owner
Charlotte-Mecklenburg Utilities	Water and Sewer	Utility Owner

Water and Sewer

If the Design-Build Team's design or construction requires the relocation of existing water or sewer facilities, the Design-Build Team shall provide Charlotte-Mecklenburg Utilities (CMU) Engineering Contractor, Hinde Engineering, with accepted preliminary roadway plans, geopak files, and cross sections. Hinde Engineering will develop designs and prepare all plans for needed agreements and permits. It is anticipated that Hinde Engineering will complete this work, obtain CMU review, and secure the CMU utility construction permits within 45 working days of receipt of the preliminary roadway plan information above. The costs for all engineering charges associated with the design and CMU permits for relocation of these existing water and / or sewer facilities shall be the responsibility of the NCDOT as part of a preliminary engineering agreement. The Design-Build Team shall remain responsible for including the utility construction details in their permit application for this project.

For the construction of the aforementioned CMU water and sewer facilities, the Design-Build Team shall not include the construction costs in their lump sum bid for the entire project but instead will be compensated in accordance with Subarticle 104-8(a) of the 2012 NCDOT *Standard Specifications for Roads and Structures*. The Design-Build Team shall negotiate line item costs for all work associated with relocating the Charlotte-Mecklenburg Utilities Department facilities with CMU. Should the Design-Build Team and CMU fail to reach an agreement through these negotiations, the Design-Build Team shall allow CMU to relocate its facilities and the Design-Build Team shall not be granted contract time extensions or receive additional compensation.

Hinde Engineering shall be responsible for submitting five (5) sets of 11 x 17 utility construction drawings to the State Utility Agent, via the Transportation Program Management Director, for further handling. The necessary Utility Agreement with CMU for reimbursement to the NCDOT shall be a two party agreement between the NCDOT and CMU; and will be developed and executed by the Department.

The relocation of all CMU facilities shall be done in accordance with the latest CMU design requirements and permits. The Department and CMU will both have inspection authority of the utility installation. The Design-Build Team may obtain the CMU design requirements / specifications from the website noted below or by calling 704-336-7600.

<http://www.charmeck.org/Departments/Utilities/Home.htm>

Utility Relocation Plans

In the event of a utility conflict, the Design-Build Team shall request that the utility company submit relocation plans (Highway Construction Plans to be provided by the Design-Build Team to Utility Owners) that show existing utilities and proposed utility relocations for approval by the NCDOT.

If the Design-Build Team determines the cost to be borne by NCDOT, the Design-Build Team shall submit three (3) copies of a detailed utility relocation estimate and copies of verification of

compensable interest. The Design-Build Team shall submit (3) three copies of the Utility Relocation Plans to the NCDOT State Utility Agent, via the Transportation Program Management Director, for review and approval prior to relocation work beginning. The Design-Build Team shall also be responsible for submitting the appropriate agreements to be used with the Utility Relocation Plans (See Agreements found elsewhere in this scope of work). After the review process is complete, the NCDOT Utility Coordination Unit will submit one (1) copy of the Utility Relocation Plans, executed agreements and any necessary comments back to the Design-Build Team. The NCDOT Utility Coordination Unit will also submit a copy of the approved Utility Relocation Plans to the Department's Resident Engineer. If the Utility Relocation Plans are approved subject to changes, it shall be the Design-Build Team's responsibility to coordinate these changes with the appropriate utility company.

Compensable Interest

Typically, affidavits, recorded easements or NCDOT agreements can serve as evidence of prior rights. A compensable interest is identified as follows:

- (A) Existing or prior easement rights within the limits of the project, either by recorded right of way or adverse possession (Utility occupying the same location for twenty (20) plus years outside the existing highway rights of way).
- (B) Entities covered under *General Statute 136-27.1* and *136-27.2*. Statute requires the NCDOT to pay the non-betterment cost for certain water, sewer and gas relocations.
- (C) Utilities that have a joint-use agreement that constitutes a compensable interest with entities that have existing or prior easements rights within the project limits.

Work Performed by Design-Build Team for Utility Owners

If the Design-Build Team elects to make arrangements with a Governmental Agency or any other utility owner for proposed utility construction, in which the Agency / Utility Owner shall be responsible for the costs of work to be performed by the Design-Build Team, the Design-Build Team shall be responsible for negotiating all costs associated with the proposed construction. Once the Design-Build Team and the Agency / Utility Owner agree on a plan and a lump sum estimated cost for the utility construction, the Design-Build Team shall be responsible for submitting five (5) sets of 11 x 17 utility construction drawings to the State Utility Agent, via the Transportation Program Management Director, for further handling. Each set shall include a title sheet, plan sheets, profiles and special provisions if required. Also, a letter from the Agency / Utility Owner agreeing to the plans and lump sum cost must accompany this package. The NCDOT will reimburse the Design-Build Team the estimated lump sum cost under a Supplemental Agreement. The necessary Utility Agreement to the Agency / Utility Owner for reimbursement shall be a two party agreement between the NCDOT and the Agency / Utility Owner; and will be developed and executed by the Department.

If the Design-Build Team is requested, in writing, by a utility company to relocate facilities not impacted by the project's construction, and / or upgrade or incorporate new facilities as part of the highway construction, designs shall be coordinated with the Utility Owner and NCDOT Utility Coordination Unit. The associated design and construction costs shall be negotiated and agreed upon between the Design-Build Team and the utility company. The Design-Build Team shall develop designs; prepare all plans for needed agreements and permits; submit permits directly to the agencies and obtain approval from the agencies. The Design-Build Team shall be responsible for all permit fees.

Cable TV

The cost in relocating CATV due to the highway construction shall be the responsibility of the CATV Company; however, under the following conditions the Department shall bear the relocation expense:

- (A) If the CATV Company can validate a recorded easement for facilities outside the maintained NCDOT rights of way.
- (B) The adjustment is needed on existing utility poles to accommodate a proposed NCDOT Traffic Management System Fiber Optic Communication Cable Project.

The NCDOT will not permit CATV to place poles within the highway rights of way but will allow down guys for their facilities within the highway rights of way. Under most circumstances, the CATV Company will continue a joint-use attachment with the local Power and Telephone Company. If the CATV proposed relocation places buried facilities within the highway rights of way then plans and encroachment agreements shall be required by the NCDOT.

Communication Cables / Electrical Services for Lighting, Signing and ITS Devices:

Prior to establishing the location for new meter poles / boxes, the Design Build Firm shall coordinate with the local Power Distribution Company concerning accessibility of E/C service and safety in maintenance of the meter.

Prior to installation, the Design-Build Team shall provide plans for review and approval for all service taps that require a parallel installation within the C/A. The Design-Build Team shall coordinate with the Engineer to follow protocol specific to Division 10 for establishing electrical services.

Preferably, parallel service installations within a C/A shall be buried and located as close to the R/W line as practical. Only due to unusual circumstances will parallel aerial service installations within C/A be allowed. The Design-Build Team shall justify the allowance of parallel aerial service installation and obtain NCDOT approval prior to installation.

The Design Build Team shall be responsible for all coordination activities, and costs, including but not limited to deposit fees, required for the utility company to provide service taps. Prior to the Design-Build Team developing the associated design and or instructing the utility company

to proceed with providing the service taps, the Design-Build Team shall obtain written approval of the service tap location(s) from the Resident Engineer.

Adjusting Existing Utilities due to Proposed Traffic Management Systems Fiber Optic Communications Cables:

The Design-Build Team shall be responsible for all costs associated with the coordination and adjustment / relocation of utilities that are in conflict with proposed ITS or signal communication cables.

Attachments to existing and / or proposed structures

Utility attachments to bridges will not be allowed.

General

The Design-Build Team shall not commence work at points where the highway construction operations are adjacent to utility facilities, until making arrangements with the utility company to protect against damage that might result in expense, loss, disruption of service or other undue inconvenience to the public or utility owner. The Design-Build Team shall be responsible for damage to the existing or relocated utilities resulting from the Team's operations. In the event of interruption of any utilities by the project construction, the Design-Build Team shall promptly notify the proper authority (Utility Company) and cooperate with the authority in the prompt restoration of service.

The Design-Build Team shall accommodate utility adjustments, reconstruction, new installation and routine maintenance work that may be underway or take place during the progress of the contract.

The Design-Build Team shall make arrangements to relocate water, sewer and gas line facilities in which the entities are covered under General Statute 136-27.1 or 136-27.2 and / or occupy a compensable interest. Unless noted otherwise elsewhere in this RFP, the non-betterment costs associated with this work shall be borne by the Design-Build Team.

The Design-Build Team shall be required to use the guidelines as set forth in the following:

- (A) *NCDOT Utility Manual - Policies & Procedures for Accommodating Utilities on Highway Rights of Way*
- (B) *Federal Aid Policy Guide - Subchapter G, Part 645, Subparts A & B*
- (C) *Federal Highway Administration's Program Guide, Utility Adjustments & Accommodations on Federal Aid Highway Projects*
- (D) *NCDOT Construction Manual Section 105-8*
- (E) *NCDOT Right of Way Manual - Chapter 16 Utility Relocations*

- (F) *NCDENR Public Water Supply* - Rules governing public water supply
- (G) *NCDENR Division of Water Quality* - Title 15A - Environment and Natural Resources

Agreements

If a utility company can provide evidence of prior rights of way or a compensable interest in their facilities, the Design-Build Team shall coordinate the non-betterment utility relocation cost with the utility company and develop the Utility Agreement.

The NCDOT State Utility Agent must execute approved agreements on Design-Build projects. The Utility Relocation Agreements (Cost Agreement) and encroachment agreements are available from the NCDOT Utility Coordination Unit. (Reference Pages 59 and 60 of the *NCDOT Utility Manual on Policies & Procedures for Accommodating Utilities on Highway Rights of Way* for the different types of encroachment agreements available for use.)

The Design-Build Team shall be required to utilize the NCDOT Standard Utility Encroachment Agreements as necessary in relocating utilities. The Encroachment Agreements shall be used under the following conditions:

- (A) If a utility company is not occupying a valid right of way / compensable interest and the proposed relocation will place the relocated utilities within the existing or proposed highway rights of way.
- (B) For all new utility installations within the existing or proposed highway rights of way. This includes all water, sewer and gas lines owned by entities covered under *General Statute 136-27.1* and *136-27.2*.
- (C) In either case above, the Design-Build Team shall submit 5 copies of the encroachment plans plus 2 originals and 3 copies of the encroachment agreement to the NCDOT State Utility Agent, via the Transportation Program Management Director, for approval.

GEOENVIRONMENTAL SCOPE OF WORK (10-21-11)**I. DEFINITION**

For the purpose of this scope of work, contamination / contaminants are defined as any substance, which when discharged in any quantity may present an imminent and substantial danger to the public health or welfare. Petroleum is defined as any oil of any kind and in any form, including, but not limited to, crude oil, diesel fuel, fuel oil, gasoline, lubrication oil, oil refuse, oil mixed with other waste, oil sludge, petroleum related products or by-products, and all other liquid hydrocarbons, regardless of specific gravity, whether singly or in combination with other substances.

II. DESCRIPTION OF WORK

The Department's GeoEnvironmental Impact Evaluation Report identified seven sites of concern in the project study area that have known or potential soil contamination. If additional right of way beyond what is shown on the Public Hearing Map is required on any of the aforementioned identified sites of concern, the Department shall require 30 business days to review the Right of Way Plans developed by the Design-Build Team and provide right of way recommendations. The Department will require 30 business days to remove any contaminated material or tanks from the property after receiving written notification from the Design-Build Team that the property has been acquired and cleared of aboveground structures.

In the unlikely event that the Design-Build Team encounters unknown contaminated materials, these materials will be handled in accordance with Article 107-25 of the 2012 *Standard Specifications for Roads and Structures*.

The Design-Build Team shall adhere to all Right of Way Branch procedures regarding the acquisition of contaminated property and if applicable, any Right of Way Acquisition Recommendations provided by the Department. The Design-Build Team shall notify the Transportation Program Management Director in writing of any underground fuel, chemical, or heating oil tanks found during property appraisals. The Department shall require 30 business days to investigate the property and provide right of way recommendations after receiving written notification from the Design-Build Team.

III. INFORMATION PROVIDED BY NCDOT

- GeoEnvironmental Impact Evaluation Report.

EROSION AND SEDIMENTATION CONTROL SCOPE OF WORK (10-21-11)

The NCDOT Roadside Environmental Unit shall review and accept all Erosion and Sedimentation Control Plans. Clearing & Grubbing and Final Grade Release for Construction (RFC) Erosion Control Plans shall be submitted to all NCDOT Personnel listed in the Design-Build Submittal Guidelines before **any** land disturbing activities, including clearing and grubbing, can commence. If the Design-Build Team chooses to perform the work in discrete sections, then a complete set of Clearing & Grubbing and Final Grade RFC Erosion Control Plans shall be submitted, accepted, and distributed as noted above prior to land disturbing activities, including clearing and grubbing, commencing in that section. No land disturbing activities, including clearing and grubbing, shall occur in any location that does not have accepted Clearing & Grubbing and Final Grade RFC Erosion Control Plans. Refer to the most recent version of the *NC DENR - Erosion and Sediment Control Planning and Design Manual* for erosion control design guidelines not addressed in this Scope of Work.

Prior to any land disturbing activities, the Design-Build Team shall submit a Vegetation Management Plan for the Department's review and acceptance. The Vegetation Management Plan shall include, but not be limited to, provisions for the early establishment of grasses / vegetation, and procedure and schedule details for fertilizer topdressing, supplemental seeding, mowing and repair seeding. The Vegetation Management Plan shall be closely coordinated with the grading and hauling operations. The Design-Build Team shall provide a narrative overview of the Vegetation Management Plan in the Technical Proposal.

From the beginning through the end of construction, the Design-Build Team shall maintain comprehensive "red-line" As-Built Plans that detail when and where permanent / temporary / repair seeding and topdressing have been performed.

Erosion and Sedimentation Control Plans shall at a minimum address the following:

I. Complete Set of Plans**A. Clearing and Grubbing Phase**

1. Use correct NCDOT symbology
2. Protect existing drainage structure inlets with Rock Inlet Sediment Trap Type 'A' (RIST-A), Rock Inlet Sediment Trap Type 'C' (RIST-C), Rock Pipe Inlet Sediment Trap Type 'A' (PIST-A), etc.
3. Utilize adequate perimeter controls (temporary silt ditches (TSD), temporary silt fence (TSF), etc.)
4. Utilize skimmer basins and rock measures with sediment control stone (Temporary Rock Sediment Dam Type 'B' (TRSD-B), Temporary Rock Silt Check Type 'A' (TRSC-A), etc.) at drainage outlets
5. Take into account existing topography and show contour lines

6. Utilize Temporary Rock Silt Checks Type 'B' (TRSC-B) to reduce velocity in existing ditches with spacing of 250 feet divided by percentage of ditch grade. Also utilize TRSC-Bs in proposed TSDs and temporary diversions (TD)
7. Protect existing streams; do not place erosion control devices in live streams
8. Provide adequate silt storage for 3600 cubic feet per disturbed acre and sediment basins shall be sized with surface area equal to 435 square feet per cubic foot per second (cfs) of the peak inflow rate, Q10, using 10-year peak rainfall data (*NCDENR - Erosion and Sediment Control Planning and Design Manual* or NOAA's National Weather Service web site http://hdsc.nws.noaa.gov/hdsc/pfds/orb/nc_pfds.html for partial duration (ARI) time series type). A Sediment Basin Designer Spreadsheet will be provided by the NCDOT Roadside Environmental Unit upon request.
9. Design Riser Basins to the following standards:
 - a. Surface Area shall be determined by Equation $A(\text{sq. feet}) = Q10 (\text{cfs}) * 435$
 - b. Volume requirement shall be 1800 cubic feet per disturbed acre draining to the riser basin
 - c. Riser Pipe shall have a cross-sectional area 1.5 times that of the barrel pipe
 - d. The riser pipe shall be non-perforated with a skimmer attached to the bottom of the pipe one foot from the bottom of the basin
 - e. See *NCDENR - Erosion and Sediment Control Planning and Design Manual* for additional design criteria
10. Skimmer Basins shall provide adequate silt storage for 1800 cubic feet per disturbed acre with surface area equal to 325 square feet per cubic foot per second (cfs) of the peak inflow rate, Q10, using the 10-year peak rainfall data (*NCDENR - Erosion and Sediment Control Planning and Design Manual* or NOAA's National Weather Service web site http://hdsc.nws.noaa.gov/hdsc/pfds/orb/nc_pfds.html for partial duration (ARI) time series type). A Skimmer Basin Designer Spreadsheet will be provided by the NCDOT Roadside Environmental Unit upon request.
11. The minimum and maximum length to width ratio of all Sediment Basins shall be 2:1 and 6:1, respectively.
12. Coir Fiber Baffles shall be installed in all silt basins and sediment dams at drainage outlets. For silt basins with a 20-foot or longer length, three Coir Fiber Baffles shall be installed with a spacing of 1/4 the basin length. For silt basins with a length less than 20 feet, a minimum of two Coir Fiber Baffles shall be installed, with a spacing of 1/3 the basin length. The Design-Build Team will not be required to show the individual baffles on the Erosion Control Plans, but shall be required to incorporate the Coir Fiber Baffle Detail on the Erosion Control Plans.
13. Include any culvert and / or pipe construction sequence plan sheets in the Clearing & Grubbing Erosion Control Plans; all pipes 48 inches or larger, or any combination of pipes that total 48 inches or more require a construction sequence. Prior to installation of pipes smaller than 48 inches in jurisdictional areas, the Design Build Team shall submit a phasing plan for managing the watercourse to the Resident Engineer for review and acceptance. The phasing plan shall be in accordance with the Best Management Practices for Construction and Maintenance Activities.
14. Incorporate temporary sediment basins into permanent stormwater devices.

15. Utilize Coir Fiber Wattles with Polyacrylamide (PAM) and/or TRSC-As with Matting and PAM in temporary and permanent, existing and proposed ditches at a spacing of 50 feet in areas where sediment basins are not feasible at drainage outlets, and in areas where sediment basins at drainage outlets with sediment traps (i.e. PIST-A, RIST-A, etc.), cannot be properly sized to surface area and / or sediment storage requirements due to safety concerns, right of way restrictions, utility conflicts or other construction limitations approved by the Roadside Environmental Unit.

B. Final Grade Phase

1. Use correct NCDOT symbology
2. Protect existing and proposed drainage structure inlets with RIST-A, RIST-C, PIST-A, etc.
3. Utilize adequate perimeter controls (TSD, TSF, etc.)
4. Utilize TRSC-Bs to reduce velocity in existing and proposed ditches with spacing of 250 feet divided by percentage of ditch grade. Also utilize TRSC-Bs in proposed TSDs and TDs
5. Utilize temporary slope drains and earth berms at top of fill slopes 8 feet or higher and a fill slope grade of 3:1 or steeper, or where there are superelevations above 0.04 and fills are greater than 5 feet. Maximum slope drain spacing shall be 200 feet.
6. Utilize rock energy dissipater and / or silt basin at outlet of slope drain
7. Devices at all drainage turnouts shall utilize skimmer or sediment control stone (TRSD-B, TRSC-A, etc.) and a spillway with an adequately designed base length to distribute outflow
8. Provide adequate silt storage for 3600 cubic feet per disturbed acre and sediment basins shall be sized with surface area equal to 435 square feet per cubic foot per second (cfs) of the peak inflow rate, Q10, using 10-year peak rainfall data (*NCDENR - Erosion and Sediment Control Planning and Design Manual* or NOAA's National Weather Service web site http://hdsc.nws.noaa.gov/hdsc/pfds/orb/nc_pfds.html for partial duration (ARI) time series type). A Sediment Basin Designer Spreadsheet will be provided by the NCDOT Roadside Environmental Unit upon request
9. Provide matting for erosion control in all ditch lines, including but not limited to temporary ditch lines (TDs) utilized to divert offsite runoff around construction areas, where the velocity is greater than 2.0 ft/s, and the shear stress is 1.55 psf or less. For ditch lines with a shear stress above 1.55 psf, Permanent Soil Reinforcement Mat or Rip Rap shall be utilized
10. Provide matting for erosion control on all fill slopes 2:1 or steeper
11. Design Riser Basins to the following standards:
 - a. Surface Area shall be determined by Equation $A(\text{sq. feet}) = Q10 (\text{cfs}) * 435$
 - b. Volume requirement shall be 1800 cubic feet per disturbed acre draining to the riser basin
 - c. Riser Pipe shall have a cross-sectional area 1.5 times that of the barrel pipe
 - d. The riser pipe shall be non-perforated with a skimmer attached to the bottom of the pipe one foot from the bottom of the basin

- e. See *NCDENR - Erosion and Sediment Control Planning and Design Manual* for additional design criteria
12. Skimmer Basins shall provide adequate silt storage for 1800 cubic feet per disturbed acre with surface area equal to 325 square feet per cubic foot per second (cfs) of the peak inflow rate, Q10, using the 10-year peak rainfall data (*NCDENR - Erosion and Sediment Control Planning and Design Manual* or NOAA's National Weather Service web site http://hdsc.nws.noaa.gov/hdsc/pfds/orb/nc_pfds.html for partial duration (ARI) time series type). A Sediment Basin Designer Spreadsheet will be provided by the NCDOT Roadside Environmental Unit upon request
13. The minimum and maximum length to width ratio of all Sediment Basins shall be 2:1 and 6:1, respectively
14. Coir Fiber Baffles shall be installed in all silt basins and sediment dams at drainage outlets. For silt basins with a 20-foot or longer length, three Coir Fiber Baffles shall be installed with a spacing of 1/4 the basin length. For silt basins with a length less than 20 feet, a minimum of two Coir Fiber Baffles shall be installed, with a spacing of 1/3 the basin length. The Design-Build Team will not be required to show the individual baffles on the Erosion Control Plans, but shall be required to incorporate the Coir Fiber Baffle Detail on the Erosion Control Plans
15. Incorporate temporary sediment basins into permanent stormwater devices
16. Utilize Coir Fiber Wattles with Polyacrylamide (PAM) and/or TRSC-As with Matting and PAM in temporary and permanent, existing and proposed ditches at a spacing of 50 feet in areas where sediment basins are not feasible at drainage outlets, and in areas where sediment basins at drainage outlets with sediment traps (i.e. PIST-A, RIST-A, etc.), cannot be properly sized to surface area and / or sediment storage requirements due to safety concerns, right of way restrictions, utility conflicts or other construction limitations approved by the Roadside Environmental Unit.

C. Intermediate Phase

Intermediate Erosion Control Plans shall only be required if design modifications and / or site conditions require additional erosion control design or design revisions to the RFC Clearing and Grubbing and / or RFC Final Grade Erosion Control Plans. Intermediate Plans shall be submitted for review and shall be accepted prior to construction of any aspect impacted by the revised erosion control design. For any intermediate phase, comply with Section B, "Final Grade Phase" above.

II. Detail Sheets and Notes

- A. Provide project specific special notes and details such as temporary rock silt check type B, coir fiber baffle, skimmer basin, coir fiber wattle with Polyacrylamide (PAM), etc.
- B. Provide matting summary sheet(s): matting for erosion control and permanent soil reinforcement mat
- C. Provide reforestation sheet(s): regular, wetland, streambank and / or buffer showing appropriate species

III. Title Sheet

- A. Show correct notes: HQW, ESA, clearing and grubbing, etc.
- B. Show correct standards for project
- C. List of standard NCDOT symbology
- D. Show name and certification number of Level IIIA certified individual responsible for designing and / or reviewing Erosion and Sedimentation Control Plans

IV. Special Provisions

- A. Erosion Control Special Provisions are available at the following website:
http://www.ncdot.org/doh/operations/dp_chief_eng/roadside/soil_water/special_provisions/
- B. References in Erosion Control Special Provisions from the aforementioned website to Method of Measurement, Basis of Payment, or any other statement regarding direct payment for Erosion & Sediment Control measures shall be disregarded
- C. Erosion Control / Stormwater Certification found elsewhere in this RFP

V. Miscellaneous

- A. Plan submittals shall include all pertinent design information required for review, such as design calculations, drainage areas, etc.
- B. The NCDOT Roadside Environmental Unit will provide a sample set of Erosion and Sedimentation Control Plans (including any special details or special provisions used by the NCDOT Roadside Environmental Unit and MicroStation Erosion Control Workspace to the Design-Build Team for reference upon request.
- C. Plans shall address any environmental issues raised during the permitting process.
- D. Sufficient time shall be allowed for the Design-Build Team to make any changes to the Erosion and Sedimentation Control Plans deemed necessary by the NCDOT Roadside Environmental Unit.
- E. Temporary access and haul roads, other than public roads, constructed or used in connection with the project shall be considered a part of the project and addressed in the Erosion and Sedimentation Control Plans.
- F. Borrow or waste areas that are part of the project shall require a separate Reclamation Plan, unless the borrow or waste activity is regulated under the *Mining Act of 1971*, or is a landfill regulated by the Division of Solid Waste Management (NCDENR). The Design-Build Team shall submit the permit number for waste / borrow sites covered by the Mining Act or regulated by DSWM (DENR) concurrently to the Transportation Program Management Director and the Resident Engineer. For Reclamation Procedures, see:

http://www.ncdot.org/doh/operations/dp_chief_eng/roadside/fieldops/downloads/Files/ContractedReclamationProcedures.pdf

- G. Whenever the Engineer determines that significant erosion and sedimentation continues despite the installation of approved protective practices, the Design-Build Team shall be required to and shall take additional protective action.

- H. An accepted Erosion and Sedimentation Control Plan does not exempt the Design-Build Team from making every effort to contain sediment onsite.
- I. Any Erosion Control Design revisions made during the construction of the project shall be submitted to the NCDOT Roadside Environmental Unit by the 15th of the month via the Transportation Program Management Director. At anytime requested by the Engineer or the NCDOT Roadside Environmental Unit, the Design-Build Team shall provide an updated version of the Erosion and Sedimentation Control Plans for distribution to all parties involved in the construction process.
- J. The Design-Build Team shall comply with the *North Carolina Administrative Code Title 15 A Department of Environment and Natural Resources Chapter 4, Sediment Control*.
- K. A pre-design meeting shall take place between the NCDOT Roadside Environmental Unit Soil & Water Engineering Section, the Design-Build Team, and any other pertinent NCDOT personnel before any Erosion and Sedimentation Control Designs are submitted to the NCDOT Roadside Environmental Unit. Erosion and Sedimentation Control Plan submittals shall only be reviewed and accepted by the NCDOT Roadside Environmental Unit after the Erosion Control Pre-Design Meeting. The Design Build Team shall be required to submit a tentative Erosion and Sedimentation Control Plan submittal schedule at the pre-design meeting.
- L. At minimum, the Design-Build Team shall bring one erosion control plan sheet with a Clearing & Grubbing erosion control design to the Erosion and Sedimentation Control Plan pre-design meeting.
- M. All RFC Erosion and Sedimentation Control Plans, including any red line revisions, shall be kept on site at all times throughout the duration of the project.
- N. Erosion Control / Stormwater Certification shall be required according to the Project Special Provision found elsewhere in this RFP.
- O. Prior to installation of any erosion control devices, the Design-Build Team shall verify boundaries of jurisdictional areas in the field and delineate with Safety Fence or flagging. For guidance on Safety Fence and flagging in jurisdictional areas, see:

http://www.ncdot.org/doh/operations/dp_chief_eng/roadside/fieldops/downloads/

- P. Once RFC Erosion and Sedimentation Control Plans are issued, any major design change or addition, any change that involves calculations, and any addition, deletion, or relocation of a sediment basin shall be submitted to the NCDOT Roadside Environmental Unit for review and acceptance. Minor changes such as moving silt fence, adding or moving temporary ditches (unless adding new flow to a sediment basin), and adding or moving slope drains shall be reviewed by the Engineer in the field.
- Q. Sediment basins that drain directly into jurisdictional water or have a total drainage area of one acre or more, shall be designed and constructed with outlet structures that only withdraw water from the surface. For sediment basins that do not drain directly into jurisdictional water or have less than one acre of total drainage area, surface dewatering outlets and stone outlets may be provided.
- R. Ground cover stabilization shall comply with the timeframe guidelines specified by the North Carolina Department of Environment and Natural Resources Division of Water Quality NCG-010000 General Construction Permit that became effective on

August 3, 2011. Excluding the slopes noted below, temporary and permanent ground cover stabilization shall be provided within seven calendar days from the last land-disturbing activity. The Design-Build Team shall label all slopes subject to the seven-day ground cover stabilization requirements on all Erosion and Sedimentation Control Plans submitted to the Department for review and acceptance.

For the slopes noted below, temporary and permanent ground cover stabilization shall be provided within 14 calendar days from the last land-disturbing activity:

- Slopes between 2:1 and 3:1, with a slope length of ten feet or less
- Slopes 3:1 or flatter, with a slope length of 50 feet or less
- Slopes 4:1 or flatter

Temporary and permanent ground cover stabilization shall be provided in accordance with the provisions in this contract and the Vegetation Management Plan developed by the Design-Build Team.

Ground cover stabilization shall be done in accordance with the following:

Short Term Stabilization: 0 – 14 Days

At a minimum, erodible areas that will not be disturbed for 14 days or less shall be stabilized utilizing non-vegetative cover. Non-vegetative cover options include straw mulch, hydraulic applied erosion control products or rolled erosion control products.

Mid-Term Stabilization: 14 – 90 Days

Erodible areas that will not be disturbed for more than 14 days and less than 90 days shall be stabilized utilizing the following stabilization protocol:

September 1 – May 31

50# Rye Grain or Wheat
500# Fertilizer
4000# Limestone

June 1 – August 31

50# German or Browntop Millet
500# Fertilizer
4000# Limestone

Long Term Stabilization: 90+ Days

Erodible areas that will not be disturbed for more than 90 days shall be stabilized utilizing the following stabilization protocol:

Shoulder and Median Areas**September 1 – May 31**

20# Kentucky Bluegrass Cultivars *
 75# Hard Fescue Cultivars **
 25# Rye Grain
 500# Fertilizer
 4000# Limestone

June 1 – August 31

20# Kentucky Bluegrass Cultivars *
 75# Hard Fescue Cultivars **
 10# German or Browntop Millet
 500# Fertilizer
 4000# Limestone

Areas Beyond the Mowing Pattern, Waste and Borrow Areas**September 1 – May 31**

15# Kentucky Bluegrass Cultivars *
 30# Hard Fescue Cultivars **
 100# Tall Fescue Cultivars ***
 25# Rye Grain
 500# Fertilizer
 4000# Limestone

June 1 – August 31

15# Kentucky Bluegrass Cultivars *
 30# Hard Fescue Cultivars **
 100# Tall Fescue Cultivars ***
 10# German or Browntop Millet
 500# Fertilizer
 4000# Limestone

*** Approved Kentucky Bluegrass Cultivars**

Alpine	Bariris	Envicta	Rugby
Apollo	Bedazzled	Impact	Rugby II
Arcadia	Bordeaux	Kenblue	Showcase
Arrow	Champagne	Midnight	Sonoma
Award	Chicago II	Midnight II	

**** Approved Hard Fescue Cultivars**

Chariot	Nordic	Rhino	Warwick
Firefly	Oxford	Scaldis II	
Heron	Reliant II	Spartan II	
Minotaur	Reliant IV	Stonehenge	

***** Approved Tall Fescue Cultivars**

2nd Millennium	Duster	Magellan	Rendition
Avenger	Endeavor	Masterpiece	Scorpion
Barlexas	Escalade	Matador	Shelby
Barlexas II	Falcon II, III, IV & V	Matador GT	Signia
Barrera	Fidelity	Millennium	Silverstar
Barrington	Finesse II	Montauk	Southern Choice II
Biltmore	Firebird	Mustang 3	Stetson
Bingo	Focus	Olympic Gold	Tarheel
Bravo	Grande II	Padre	Titan Ltd
Cayenne	Greenkeeper	Paraiso	Titanium
Chapel Hill	Greystone	Picasso	Tomahawk
Chesapeake	Inferno	Piedmont	Tacer
Constitution	Justice	Pure Gold	Trooper
Chipper	Jaguar 3	Prospect	Turbo
Coronado	Kalahari	Quest	Ultimate
Coyote Kentucky 31	Rebel	Exeda	Watchdog
Davinci	Kitty Hawk	Rebel Sentry	Wolfpack
Dynasty	Kitty Hawk 2000	Regiment II	
Dominion	Lexington	Rembrandt	

From January 1 – December 31, the Design-Build Team shall apply and additional 20# of Sericea Lespedeza on cut and fill slopes 2:1 or steeper.

Fertilizer shall be 10-20-20 analysis or a different analysis that provides a 1-2-2 ratio applied at a rate that provides the same amount of plant food as a 10-20-20 analysis and as directed.

Soil Analysis

If vegetation establishment indicates a deficiency in soil nutrients or an incurred pH level is present, the Design-Build Team shall take soil samples and apply additional soil amendments to the affected area and as directed.

Fertilizer Topdressing

Fertilizer used for topdressing shall be 10-20-20 analysis applied at a rate of 500 pounds per acre; or a different analysis that provides a 1-2-2 ratio applied at a rate that provides the same amount of plant food as a 10-10-20 analysis and as directed.

Fertilizer used for waste and borrow areas shall be 16-8-8 grade applied at a rate of 500 pounds per acre; or a different analysis that provides a 2-1-1 ratio applied at a rate that provides the same amount of plant food as a 16-8-8 analysis and as directed.

Supplemental Seeding

For all supplemental seeding, the kinds of seed and proportions shall be the same as specified above for *Long Term Stabilization*. The rate of application for supplemental seeding shall be between 25# to 75# per acre. Prior to topdressing, the Design-Build Team shall determine the actual rate per acre for supplemental seeding and submit the supplemental seeding rate and areas to the Department for review and acceptance.

To prevent disturbance of existing vegetation, minimum tillage equipment, consisting of a sod seeder, shall be used to incorporate seed into the soil where degree of slope allows. Where degree of slope prevents the use of a sod seeder, a clodbuster (ball and chain) may be used.

Mowing

The minimum mowing height shall be six inches.

EROSION CONTROL LIQUIDATED DAMAGES

The Design-Build Team shall observe and comply with Federal and State Laws, Local Laws, Ordinances, and Regulations; as well as Orders and Decrees of Bodies having any jurisdiction or authority in accordance with Section 107 of the 2012 *Standard Specifications for Roads and Structures*.

The Design-Build Team shall take all reasonable precautions to comply with all regulations of all authorities having jurisdiction over public and private land governing the protection of erosion and sedimentation. Any fines, remediation required or charges levied against the Department for failing to comply with all rules and regulations concerning erosion and sediment control, due to the Design-Build Team's negligence, carelessness, or failure to implement the Erosion and Sedimentation Control Plans and Specifications; or failure to maintain an approved Storm Water Pollution Prevention Plan (SWPPP), regardless of absence of neglect, shall be deducted from monies due the Design-Build Team. In addition to said fines, remediation required, or charges levied, any associated engineering costs or actions taken by the Department in order for the Department to comply with rules and regulations, as a result of the Design-Build Team's negligence, carelessness, or failure to implement the Erosion and Sedimentation Control Plans and Specifications; and / or the SWPPP, regardless of absence of neglect, shall be deducted from the monies due to the Design-Build Team.

LIGHTING SCOPE OF WORK (10-21-11)

Provide and install roadway lighting equipment and materials, in accordance with the Final Lighting Plans provided by the Department, Division 14 of the 2012 NCDOT *Standard Specifications for Roads and Structures*, and the *Roadway Standard Drawings*, except as amended below. Prior to the Technical Proposal submittal date, the NCDOT will provide the preliminary lighting design. The Department will finalize the lighting design based upon the Design-Build Team's Release for Construction (RFC) Roadway Plans.

After the RFC Roadway Plans have been accepted by the Transportation Program Management Director, the Design-Build Team shall submit MicroStation files of the RFC Roadway Plans for the Department to complete the lighting design. The Design-Build Team shall allow the Department ten days after this submittal to update and finalize the lighting design.

The Design-Build Team shall allow ten days for Department review of each submittal for all materials including poles and foundation designs. An additional ten days shall be required for pole submittals from vendors that do not commonly do business with the Department.

The Design-Build Team shall maintain the lighting system until the project is accepted.

Reference the Traffic Management Scope of Work found elsewhere in this RFP for time restrictions and lane closure requirements.

MAINTENANCE

The Design-Build Team shall assume responsibility for routine maintenance of the lighting system(s) for the duration of the contract in accordance with Section 1400 of the 2012 NCDOT *Standard Specifications for Roads and Structures*, except as amended below.

NCDOT will assume maintenance responsibility for the completed lighting systems after the project is accepted, and there is no chance of construction-related damage.

The Design-Build Team shall re-lamp, repair and / or replace any newly installed non-functional luminaires within the project limit. All luminaires must be operational at project completion.

CONSTRUCTION PHASING

At the I-77 interchange, the lighting system shall be kept in service as long as possible before cut over to newly installed circuitry shown on the plan sheets developed by the Department.

ENVIRONMENTAL PERMITS SCOPE OF WORK (10-21-11)**General**

The Design-Build Team shall be responsible for preparing all documents necessary for the Department to obtain the environmental permits for the construction of this project. Permit applications shall be required for the: US Army Corps of Engineers (USACE) Section 404 Permit, NC Department of Natural Resources (DENR) Division of Water Quality (DWQ) Section 401 Water Quality Certification and NC Department of Natural Resources (DENR) State Stormwater Permit. Based on the anticipated limited impacts to jurisdictional resources, a Nationwide Permit No. 23 is probable. Thus, the timeline for obtaining the permits outlined in this scope of work reflects that a Nationwide Permit No. 23 will be required; and the Department will not honor any requests for additional contract time or compensation for any efforts required in order to obtain an Individual Permit, including but not limited to public involvement, additional design effort, additional construction effort and / or additional environmental agency coordination and approvals.

The Design-Build Team shall not begin ground-disturbing activities, including utility relocation in jurisdictional areas, until the environmental permits have been issued (this does not include permitted investigative borings covered under a Nationwide Permit No. 6 and utility relocation work outside jurisdictional resources noted below). The Design-Build Team shall not be allowed to operate under the Department's Nationwide Permit No. 6

The Design-Build Team may begin utility relocation work prior to obtaining the aforementioned permits provided that (1) the Department is notified in writing prior to these activities; (2) such activities are outside jurisdictional resources (3) a meeting is held with the NCDOT and permitting agencies prior to beginning work, if necessary; and (4) the Design-Build Team submits a Preconstruction Notification for the Department to forward to the permitting agencies, if necessary.

Except to obtain a Nationwide Permit No. 6 for investigative borings, the Department will allow no direct contact between the Design-Build Team and representatives of the environmental agencies. No contact between the Design-Build Team and the environmental agencies shall be allowed either by phone, e-mail or in person, without representatives of the Department's Project Development & Environmental Analysis (PDEA) Branch and / or the Division's Environmental Officer present. A representative from the Transportation Program Management shall be included on all correspondence.

Project R-4902 is not in the Merger 01 Process used by the environmental agencies and the Department to obtain environmental permits. On Non-Merger Projects, the Department has committed to coordination efforts with the environmental agencies. Thus, the Design-Build Team shall conduct an interagency meeting that includes NCDOT PDEA Natural Environmental Unit (NEU), NCDOT Hydraulic Unit and interested environmental agencies to review the hydraulic design and permit sites prior to submittal of the environmental permit application. All work resulting from the hydraulics and permit reviews shall be the responsibility of the Design-

Build Team. Failure on the part of the Design-Build Team to coordinate this interagency meeting, places all responsibility for associated delays solely in the hands of the Design-Build Team.

The Design-Build Team shall be bound by the terms of all signed planning documents and commitments made during the aforementioned interagency meeting. The Design-Build Team shall be held accountable for meeting all permit conditions. The Design-Build Team shall be required to staff any personnel necessary to provide permit compliance.

Major Permit Application Process

It shall be the Design-Build Team's responsibility to acquire information and prepare permit drawings that reflect the impacts and minimization efforts resulting from the interagency coordination and as designed by the Design-Build Team. Further it shall be the Design-Build Team's responsibility to provide these permit impact sheets (drawings) depicting the design and construction details to the Department as part of the permit application. The Design-Build Team shall be responsible for developing the permit application for all jurisdictional impacts. The permit application shall include all utility relocations. The permit application shall consist of, at a minimum, the following:

- Cover Letter
- Minutes from the interagency meeting
- Permit drawings (with and without contours)
- Half-size plans
- Completed forms appropriate for impacts

The Department will re-verify and update, as needed, the required environmental data that expires prior to the completion of the activity causing the impact in the jurisdictional areas. These include, but are not limited to, federally protected species, re-verification of wetland jurisdictional areas, historic and archaeological sites, and 303d (impaired) streams.

The Design-Build Team shall submit one permit application for the entire project. The Design-Build Team shall not submit multiple applications to develop a "staged permitting" process to expedite construction activities in a phased fashion.

Direct coordination between the Design-Build Team, the Department's Transportation Program Management Director, Resident Engineer, Division Environmental Officer (DEO) and the Project Development and Environmental Analysis Branch - Natural Environment Unit (PDEA-NEU) shall be necessary to ensure proper permit application development. Upon completion of the permit application package, the Design-Build Team shall concurrently forward the package to the Transportation Program Management Director, Resident Engineer, Division Environmental Officer (DEO), Hydraulics Unit and PDEA-NEU for review and approval. After all revisions are complete, the Department will subsequently forward the package to the appropriate agencies to have the permit application placed on public notice.

Any temporary construction measures, including de-watering, construction access, etc. shall be addressed in the permit application. Impacts that result from so-called temporary measures may not be judged to be temporary impacts by the environmental agencies. These issues shall be addressed and reviewed by PDEA-NEU prior to the interagency meeting and resolved with the environmental agencies during the interagency meeting.

The Design-Build Team shall clearly indicate the location of and impacts of haul roads and utility relocations on jurisdictional areas. The Design-Build Team shall also identify all proposed borrow and waste sites. These details shall be included in the permit application data. Further, the Design-Build Team shall describe the methods of construction of all structures. The description of the temporary impacts (haul roads, utility relocations, work bridges, etc.) shall include restoration plans, schedules, and disposal plans. This information shall be included in the permit application. This information shall also be part of the data presented during the interagency meeting.

The NCDOT hereby commits to ensuring, to the greatest extent possible, that the footprint of the impacts in areas under the jurisdiction of the federal Clean Water Act will not be increased during the Design-Build effort. All fill material shall be immediately stabilized and maintained to prevent sediment from entering adjacent waters or wetlands. The Design-Build Team shall be responsible for ensuring that the design and construction of the project will not impair the movement of aquatic life.

Requests made for modifications to the permits obtained by the Design-Build Team shall only be allowed if the Engineer determines it to be in the best interest of the Department and shall be strongly discouraged. The Design-Build Team shall not take an iterative approach to hydraulic design issues. The hydraulic design shall be complete prior to the permit application.

Individual Permit Timeframe

The Design-Build Team should expect it to take up to seven months to accurately and adequately complete all designs necessary for permit application, submit application to the Department, and obtain approval for the permits from the environmental agencies. Agency review time will be approximately 90 days from receipt of a “complete” package. No requests for additional contract time or compensation will be allowed if the permits are obtained within this seven-month period. With the exception of location and survey work, utility relocation work outside jurisdictional resources that adheres to the aforementioned requirements, and permitted investigative borings covered under a Nationwide Permit No. 6 secured by the Design-Build Team, no mobilization of men, materials, or equipment for site investigation or construction of the project shall occur prior to obtaining the permits (either within the seven-month period or beyond the seven-month period). The Department will not honor any requests for additional contract time or compensation, including idle equipment or mobilization or demobilization costs, for the Design-Build Team mobilizing men, materials (or ordering materials), or equipment prior to obtaining all permits. The Department will consider requests for contract time extensions for obtaining the permits only if the Design-Build Team has pursued the work with due diligence, the delay is beyond the Team’s control, and the seven-month period has been exceeded. If time were granted

it would be only for that time exceeding the seven-month period. This seven-month period is considered to begin on the Date of Availability as noted elsewhere in this RFP.

The Design-Build Team needs to be aware that the timeframes listed above for the NCDWQ and the USACE to review a permit application and / or modification begin only after a fully complete and 100% accurate submittal.

Mitigation Responsibilities of the Design-Build Team

The Department has acquired the compensatory mitigation for unavoidable impacts to wetlands and surface waters due to the project construction from the Ecosystem Enhancement Program (EEP). This mitigation was based on impacts as identified in the planning stage.

Any changes proposed by the Design-Build Team to any design or construction details provided by the Department shall be approved by the Department prior to being submitted to the resource agencies for their approval.

Should additional jurisdictional impacts result from revised design and / or construction methods, suitable compensatory mitigation for wetlands and / or streams shall be the sole responsibility of the Design-Build Team. Therefore, it is important to note that additional mitigation will have to be approved by the environmental agencies and such approval shall require, at a minimum, the preparation and approval of a Mitigation Plan before permits / permit modifications are approved and before construction can commence. To mitigate for these additional jurisdictional impacts, the Design-Build Team shall be responsible for all costs associated with acquiring suitable mitigation. Construction of any on-site mitigation shall be performed by a contractor that has successfully constructed similar on-site mitigation. In the absence of suitable on-site mitigation, the Design-Build Team shall be responsible for acquiring additional mitigation from the EEP.

The Design-Build Team shall analyze all new areas to be impacted that have not been analyzed during the NEPA Process and any staging areas that are located outside the project right of way. This analysis shall include performing all environmental assessments. These assessments shall require the Design-Build Team to engage the services of a competent environmental consultant to conduct a full environmental investigation to include, but not be limited to, Federally Listed Threatened and Endangered Species, wetlands, streams, avoidance and minimization in jurisdictional areas, compensatory mitigation, FEMA compliance, and historical, archaeological, and cultural resources surveys in these areas. The environmental consultant shall obtain concurrence through PDEA-NEU from the United States Fish and Wildlife Service to document compliance with Section 7 of the *Endangered Species Act* for those species requiring such concurrence. In addition, the Design-Build Team shall identify additional mitigation required, identify the amount of time beyond the seven-month period, and fulfill any other requirements that may be imposed by the permitting agencies to obtain the permit / permit modification. Any contract time extensions resulting from additional environmental assessments required by the Design-Build Team's design and / or construction methods impacting areas outside those previously analyzed through the NEPA Process shall be solely at the Department's discretion.

Commitments

The NCDOT is committed to incorporating all reasonable and practicable design features to avoid and minimize wetland impacts and to provide full compensatory mitigation of all remaining wetland impacts. Avoidance measures were taken during the planning and NEPA Process and minimization measures were incorporated as part of the preliminary design. The Design-Build Team shall incorporate these avoidance and minimization features, plus any minimization identified during the interagency meeting, into the design.

All work by the Design-Build Team must be accomplished in strict compliance with the plans submitted with the permit applications and in compliance with all conditions of all permits and certifications issued by the environmental agencies. The Design-Build Team shall provide each of its contractors and / or agents associated with the construction or maintenance of this project with a copy of the permits.

Unless noted otherwise elsewhere in this RFP, the Design-Build Team shall strictly adhere to these commitments, as well as others, including but not limited to, those included in the Categorical Exclusion, all permits and the interagency meeting.

Archeological Sites

If the Design-Build Team discovers any previously unknown historic or archeological remains while accomplishing the authorized work, they shall immediately notify the NCDOT Staff Archaeologist and / or the NCDOT Project Development Engineer, as listed below, who will initiate the required State / Federal coordination. A representative from the Transportation Program Management Office will also be notified. All questions regarding these sites should be addressed to Mr. Matthew Wilkerson, NCDOT Archaeology (919) 707-6089, or Ms. Angela Sanderson, NCDOT Project Development (919) 707-6042, ext. 310.

PUBLIC INFORMATION SCOPE OF WORK (10-21-11)

NCDOT will take the lead role on this project and be responsible for a portion of the public information efforts through the Department's Communications Office. The NCDOT responsibilities include:

- Organizing public meetings
- Providing media announcements
- Soliciting and administering advertisements, as deemed necessary
- Mailings to the identified target audiences, including postage
- Develop and produce informational print materials

The Design-Build Team shall coordinate with the Department to promote public awareness for this project. The Design-Build Team's responsibilities shall include:

- Providing details surrounding the impacts to the public
- Providing advance notice to the Department of upcoming project impacts
- Assisting the Department in the development of the target audience list
- Attending and / or speaking at public meetings
- Hand delivery of time sensitive informational materials

The Design-Build Team shall hold an initial project coordination meeting with NCDOT one month prior to start of construction to discuss project impacts to the public. This information will be used by the Department to create a Public Information Plan.

The Design-Build Team shall inform the Department at least 21 calendar days in advance of any construction activity that will have significant impact on the public, including, but not limited to, the start of construction, major traffic shifts, road closures, ramp closures, detours, night work and project completion.

NCDOT will develop, with assistance from the Design-Build Team, the specific list of target audiences for this project. The following groups are identified as typical target audiences to receive informational materials:

- Governmental agencies
- Municipalities directly affected by construction
- Transportation services
- Emergency services
- Neighborhood groups and private homes
- Industry and businesses
- Chamber of Commerce
- Individual schools effected by the project
- County / City school systems
- Any other organization as deemed necessary by the Department.

The amount of public involvement required for this project is directly based on the Design-Build Team's Traffic Control Plans and construction details. The minimum public information requirements solely associated with the Traffic Control Plans shall include, but not be limited to the following:

- Public Meetings – If Beginning of Construction meeting for area businesses and residents is held, attending and / or speaking at this event.
- Distribution of Informational Materials – For beginning of construction and for all road closures with detour routes, the Design-Build Team shall be responsible for delivering time sensitive informational material provided by the NCDOT directly to portions of the target audience. If the Design-Build Team informs the Department of the aforementioned activities less than three weeks in advance, the Design-Build Team shall hand deliver the informational materials to the impacted target audiences.

The Design-Build Team shall include in their lump sum price bid for the entire project, all costs associated with their involvement in the Public Information Scope of Work.

The Design-Build Team shall be responsible for establishing and creating the initial project website for this project. The website shall be housed on an NCDOT server. The project website shall use the current NCDOT Communications Office project web design template and adhere to current software development, security and technical infrastructure standards. All project website design and implementation shall be coordinated with Mr. Ryan Nolan, Internet Web Content Manager, NCDOT Web Services. After the initial content is established, the maintenance and any further updates to the website will be performed by the Department. All costs associated with setting up a project website shall be included in the lump sum price bid for the entire project.

***** STANDARD SPECIAL PROVISIONS *******PLANT AND PEST QUARANTINES****(Imported Fire Ant, Gypsy Moth, Witchweed, and Other Noxious Weeds)**

(3-18-03)

DB1 G130

Within Quarantined Area

This project may be within a county regulated for plant and/or pests. If the project or any part of the Design-Build Team's operations is located within a quarantined area, thoroughly clean all equipment prior to moving out of the quarantined area. Comply with federal/state regulations by obtaining a certificate or limited permit for any regulated article moving from the quarantined area.

Originating in a Quarantined County

Obtain a certificate or limited permit issued by the N.C. Department of Agriculture/United States Department of Agriculture. Have the certificate or limited permit accompany the article when it arrives at the project site.

Contact

Contact the N.C. Department of Agriculture/United States Department of Agriculture at 1-800-206-9333, 919-733-6932, or <http://www.ncagr.com/plantind/> to determine those specific project sites located in the quarantined area or for any regulated article used on this project originating in a quarantined county.

Regulated Articles Include

1. Soil, sand, gravel, compost, peat, humus, muck, and decomposed manure, separately or with other articles. This includes movement of articles listed above that may be associated with cut/waste, ditch pulling, and shoulder cutting.
2. Plants with roots including grass sod
3. Plant crowns and roots
4. Bulbs, corms, rhizomes, and tubers of ornamental plants
5. Hay, straw, fodder, and plant litter of any kind
6. Clearing and grubbing debris
7. Used agricultural cultivating and harvesting equipment
8. Used earth-moving equipment
9. Any other products, articles, or means of conveyance, of any character, if determined by an inspector to present a hazard of spreading imported fire ant, gypsy moth, witchweed or other noxious weeds.

GIFTS FROM VENDORS AND CONTRACTORS

(12-15-09)

DB1 G152

By Executive Order 24, issued by Governor Perdue, and *N.C. G.S. § 133-32*, it is unlawful for any vendor or contractor (i.e. architect, bidder, contractor, construction manager, design professional, engineer, landlord, offeror, seller, subcontractor, supplier, or vendor), to make gifts or to give favors to any State employee of the Governor's Cabinet Agencies (i.e. Administration, Commerce, Correction, Crime Control and Public Safety, Cultural Resources, Environment and

Natural Resources, Health and Human Services, Juvenile Justice and Delinquency Prevention, Revenue, Transportation, and the Office of the Governor). This prohibition covers those vendors and contractors who:

- (1) have a contract with a governmental agency; or
- (2) have performed under such a contract within the past year; or
- (3) anticipate bidding on such a contract in the future.

For additional information regarding the specific requirements and exemptions, vendors and contractors are encouraged to review Executive Order 24 and *G.S. § 133-32*.

Executive Order 24 also encouraged and invited other State Agencies to implement the requirements and prohibitions of the Executive Order to their agencies. Vendors and contractors should contact other State Agencies to determine if those agencies have adopted Executive Order 24.

BRIDGE APPROACH FILLS

(9-1-11)

DB4 R01

Description

Bridge approach fills include bridge approach fills for sub regional tier bridges and reinforced bridge approach fills. Construct bridge approach fills in accordance with the contract and *Roadway Standard Drawings* No. 422.10 or 422.11. Define “geosynthetics” as geotextiles or geomembranes.

Materials

Refer to Division 10 of the 2012 *Standard Specifications for Roads and Structures*.

Item	Section
Anchor Pins	1056-2
Geotextiles	1056
Portland Cement Concrete	1000
Select Material	1016
Subsurface Drainage Materials	1044
Wire Staples	1060-8(D)

For bridge approach fills for sub regional tier bridges, provide Type 1 geotextile for filtration geotextiles. For reinforced bridge approach fills, provide Type 5 geotextile for geotextile reinforcement and Type 1 geotextile and No. 78M stone for drains. Use Class B concrete for concrete pads.

Use Class III or V select material for reinforced bridge approach fills and only Class V select material (standard size No. 78M stone) for bridge approach fills for sub regional tier bridges. Provide PVC pipes, fittings and outlet pipes for subsurface drainage materials. For drains and PVC pipes behind end bents, use pipes with perforations that meet AASHTO M 278.

Use PVC, HDPE or linear low density polyethylene (LLDPE) geomembranes for reinforced

bridge approach fills. For PVC geomembranes, provide grade PVC30 geomembranes that meet ASTM D7176. For HDPE and LLDPE geomembranes, use geomembranes with a nominal thickness of at least 30 mils that meet Geosynthetic Research Institute Standard Specifications GM13 or GM17, respectively. Handle and store geomembranes in accordance with Article 1056-2 of the 2012 *Standard Specifications for Roads and Structures*. Provide material certifications for geomembranes in accordance with Article 1056-3 of the 2012 *Standard Specifications for Roads and Structures*.

Construction Methods

Excavate as necessary for bridge approach fills in accordance with the contract. Notify the Engineer when foundation excavation is complete. Do not place geomembranes or filtration geotextiles until excavation dimensions and foundation material are approved. Attach geomembranes and filtration geotextiles to end bent cap back and wing walls with adhesives, tapes or other approved methods. Glue or weld geomembrane seams to prevent leakage.

For reinforced bridge approach fills, place geotextile reinforcement within 3" of locations shown in Standard Drawing No. 422.10 and in slight tension free of kinks, folds, wrinkles or creases. Install geotextile reinforcement with the orientation, dimensions and number of layers shown in Standard Drawing No. 422.10. Place first layer of geotextile reinforcement directly on geomembranes with no void or material in between. Install geotextile reinforcement with the machine direction (MD) parallel to the roadway centerline. The MD is the direction of the length or long dimension of the geotextile roll. Do not splice or overlap geotextile reinforcement in the MD so seams are perpendicular to the roadway centerline. Wrap geotextile reinforcement at end bent cap back and wing walls as shown in Standard Drawing No. 422.10 and directed by the Engineer. Extend geotextile reinforcement at least 4 feet back behind end bent cap back and wing walls into select material.

Overlap adjacent geotextiles at least 18" with seams oriented parallel to the roadway centerline. Hold geotextiles in place with wire staples or anchor pins as needed. Contact the Engineer when existing or future obstructions such as foundations, pavements, pipes, inlets or utilities will interfere with geosynthetics.

For reinforced bridge approach fills, construct one foot square drains consisting of 4" diameter continuous perforated PVC pipes surrounded by No. 78M stone wrapped in Type 1 geotextiles. Install drains in accordance with Standard Drawing No. 422.10. For bridge approach fills for sub regional tier bridges, install 4" diameter continuous perforated PVC drain pipes in accordance with Standard Drawing No. 422.11.

Use solvent cement to connect PVC pipes so joints do not leak. Connect perforated pipes to outlet pipes just behind wing walls. Provide drain pipes and drains with positive drainage towards outlets. Place pipe sleeves in or under wing walls for outlet pipes so positive drainage is maintained. Use sleeves that can withstand wing wall loads.

Place select material in 8" to 10" thick lifts. Use only hand operated compaction equipment to compact select material for bridge approach fills. Compact Class III select material in accordance with Subarticle 235-3(C) of the 2012 *Standard Specifications for Roads and*

Structures. Compact No. 78M stone with a vibratory compactor to the satisfaction of the Engineer. Do not displace or damage geosynthetics, drain pipes or drains when placing and compacting select material. End dumping directly on geosynthetics is not permitted. Do not operate heavy equipment on geosynthetics, drain pipes or drains until they are covered with at least 8" of select material. Replace any damaged geosynthetics, drain pipes or drains to the satisfaction of the Engineer.

Cover open ends of outlet pipes with rodent screens as shown in Standard Drawing No. 815.03. Connect ends of outlet pipes to concrete pads or existing drainage structures as directed by the Engineer. Construct concrete pads with an Ordinary surface finish that meets Subarticle 825-6(B) of the 2012 *Standard Specifications for Roads and Structures*.

PREPARATION OF SUBGRADE AND BASE

(9-1-11)

DB5 R05

On mainline portions and ramps of this project, prepare the subgrade and base beneath the pavement structure in accordance with the applicable sections of the 2012 *Standard Specifications for Roads and Structures* except use an automatically controlled fine grading machine utilizing string lines, laser controls, or other approved methods to produce final subgrade and base surfaces meeting the lines, grades, and cross sections required by the plans or established by the Engineer.

ASPHALT PAVER - FIXED AND MOBILE STRING LINE

(9-1-11)

DB6 R07

A mobile string line consisting of a 30 to 40 foot long ski is required for the widening and resurfacing on this project. A fixed string line is required for the new pavement construction on this project.

ASPHALT BINDER CONTENT OF ASPHALT PLANT MIXES

(9-1-11)

DB6 R15

The approximate asphalt binder content of the asphalt concrete plant mixtures used on this project will be as follows:

Asphalt Concrete Base Course	Type B 25.0_	4.4%
Asphalt Concrete Intermediate Course	Type I 19.0_	4.8%
Asphalt Concrete Surface Course	Type S 4.75A	6.8%
Asphalt Concrete Surface Course	Type SF 9.5A	6.7%
Asphalt Concrete Surface Course	Type S 9.5_	6.0%
Asphalt Concrete Surface Course	Type S 12.5_	5.5%

The actual asphalt binder content will be established during construction by the Engineer within the limits established in the 2012 *Standard Specifications for Roads and Structures* or Project Special Provisions.

ASPHALT PLANT MIXTURES

(7-1-95)

DB6 R20

Place asphalt concrete base course material in trench sections with asphalt pavement spreaders made for the purpose or with other equipment approved by the Engineer.

FINAL SURFACE TESTING - ASPHALT PAVEMENTS

(9-1-11)

DB6 R45

On the mainline, auxiliary lanes, acceleration and deceleration lanes, ramps and loops, perform acceptance testing of the longitudinal profile of the finished pavement surface using an inertial profiler in accordance with Article 610-13 of the 2012 *Standard Specifications for Roads and Structures*.

On -Y- Lines of this project where the typical section requires two or more layers of new pavement, perform acceptance testing of the longitudinal profile of the finished pavement surface in accordance with Article 610-13 of the 2012 *Standard Specifications for Roads and Structures* using a North Carolina Hearne Straightedge (Model No. 1) except as modified below.

Page 6-34, Replace Table 610-8 with the following:

Adjustment Schedule for Cumulative Straightedge Index (CSI) (Obtained by adding SE Index of up to 25 consecutive 100-foot sections)		
*CSI	ACCEPTANCE CATEGORY	CORRECTIVE ACTION
0-0	Acceptable	None
1-0 or 2-0	Acceptable	None
3-0 or 4-0	Acceptable	None
Any Other Number	Unacceptable	Required

***Either Before or After Corrective Actions**

Page 6-35, Replace the 14th paragraph of Article 610-13(B) with the following:

Correct any deviation that exceeds a 0.3 inch blanking band such that the deviation is reduced to 0.2 inches or less.

Page 6-35, Replace the 16th, 17th, 18th, and 19th paragraphs of Article 610-13(B) with the following:

Take corrective actions as specified if the CSI indicates “Required” corrective action. The CSI after corrective action should meet or exceed “Acceptable” requirements.

Where corrective action is required, the test section(s) requiring corrective action will be retested, unless the Engineer directs the retesting of the entire lot.

Test sections and / or lots that are initially tested by the Design-Build Team which indicate excessive deviations such that corrective action is required, may be re-rolled with asphalt rollers while the mix is still warm and in a workable condition, to possibly correct the problem. In this instance, reevaluation of the test section(s) must be completed within 24 hours of pavement placement and these test results will serve as the initial test results.

REMOVE AND STOCKPILE EXISTING GUARDRAIL

(7-1-95) (Rev. 7-18-06)

DB8 R55

Carefully dismantle and remove existing guardrail and all components, concrete anchors included, at locations indicated in the plans and neatly stockpile it on the right of way, with the small parts stored in sturdy containers, for removal by State Forces. Dispose of the concrete anchors.

GUARDRAIL ANCHOR UNITS, TYPE M-350

(9-1-11)

DB8 R60

Description

Furnish and install guardrail anchor units in accordance with the details in the plans developed by the Design-Build Team, the applicable requirements of Section 862 of the 2012 *Standard Specifications for Roads and Structures*, and at locations shown in the plans.

Materials

The Design Build Team may, at his option, furnish any one of the following guardrail anchor units or approved equal.

The guardrail anchor unit (SRT-350) as manufactured by:

TRINITY INDUSTRIES, INC.
2525 N. STEMMONS FREEWAY
DALLAS, TEXAS 75207
TELEPHONE: 800 644-7976

The guardrail anchor unit (FLEAT) as manufactured by:

ROAD SYSTEMS, INC.
3616 OLD HOWARD COUNTY AIRPORT
BIG SPRINGS, TEXAS 79720
TELEPHONE: 915-263-2435

The guardrail anchor unit (REGENT) as manufactured by:

ENERGY ABSORPTION SYSTEMS, INC.
ONE EAST WACKER DRIVE
CHICAGO, ILLINOIS 60601-2076
TELEPHONE: 888-32-ENERGY

Prior to installation the Design Build Team shall submit to the Engineer:

1. FHWA acceptance letter for each guardrail anchor unit certifying it meets the requirements of NCHRP Report 350, Test Level 3, in accordance with Section 106-2 of the 2012 *Standard Specifications for Roads and Structures*.
2. Certified working drawings and assembling instructions from the manufacturer for each guardrail anchor unit in accordance with Section 105-2 of the 2012 *Standard Specifications for Roads and Structures*.

No modifications shall be made to the guardrail anchor unit without the express written permission from the manufacturer. Perform installation in accordance with the details in the plans, and details and assembling instructions furnished by the manufacturer.

Construction

Guardrail end delineation is required on all approach and trailing end sections for both temporary and permanent installations. Guardrail end delineation consists of yellow reflective sheeting applied to the entire end section of the guardrail in accordance with Section 1088-3 of the 2012 *Standard Specifications for Roads and Structures* and is incidental to the cost of the guardrail anchor unit.

GUARDRAIL ANCHOR UNITS, TYPE 350

(9-1-11)

DB8 R65

Description

Furnish and install guardrail anchor units in accordance with the details in the plans as developed by the Design-Build Team, the applicable requirements of Section 862 of the 2012 *Standard Specifications for Roads and Structures*, and at locations shown in the plans.

Materials

The Design-Build Team may at his option, furnish any one of the guardrail anchor units or approved equal.

Guardrail anchor unit (ET-2000) as manufactured by:

TRINITY INDUSTRIES, INC.
2525 N. STEMMONS FREEWAY
DALLAS, TEXAS 75207
TELEPHONE: 800-644-7976

The guardrail anchor unit (SKT 350) as manufactured by:

ROAD SYSTEMS, INC.
3616 OLD HOWARD COUNTY AIRPORT
BIG SPRING, TEXAS 79720
TELEPHONE: 915 263-2435

Prior to installation the Design-Build Team shall submit to the Engineer:

1. FHWA acceptance letter for each guardrail anchor unit certifying it meets the requirements of NCHRP Report 350, Test Level 3, in accordance with Section 106-2 of 2012 *Standard Specifications for Roads and Structures*.
2. Certified working drawings and assembling instructions from the manufacturer for each guardrail anchor unit in accordance with Section 105-2 of the 2012 *Standard Specifications for Roads and Structures*.

No modifications shall be made to the guardrail anchor unit without the express written permission from the manufacturer. Perform installation in accordance with the details in the plans, and details and assembling instructions furnished by the manufacturer.

Construction

Guardrail end delineation is required on all approach and trailing end sections for both temporary and permanent installations. Guardrail end delineation consists of yellow reflective sheeting applied to the entire end section of the guardrail in accordance with Section 1088-3 of the 2012 *Standard Specifications for Roads and Structures* and is incidental to the cost of the guardrail anchor unit.

IMPACT ATTENUATOR UNITS, TYPE 350

(9-1-11)

DB8 R75

Description

Furnish and install impact attenuator units and any components necessary to connect the impact attenuator units in accordance with the manufacturer's requirement, the details in the plans and at locations shown in the plans.

Materials

NON-GATING IMPACT ATTENUATOR UNITS:

The impact attenuator unit (QUADGUARD) as manufactured by:

ENERGY ABSORPTION SYSTEMS, INC.
ONE EAST WACKER DRIVE
CHICAGO, ILLINOIS 60601-2076
TELEPHONE: 312-467-6750

The impact attenuator unit (TRACC) as manufactured by:

TRINITY INDUSTRIES, INC.
2525 N. STEMMONS FREEWAY
DALLAS, TEXAS 75207
TELEPHONE: 1-800-644-7976

GATING IMPACT ATTENUATOR UNITS:

The impact attenuator unit (BRAKEMASTER) as manufactured by:

ENERGY ABSORPTION SYSTEMS, INC.
ONE EAST WACKER DRIVE
CHICAGO, ILLINOIS 60601-2076
TELEPHONE: 312-467-6750

The impact attenuator unit (CAT) as manufactured by:

TRINITY INDUSTRIES, INC.
2525 N. STEMMONS FREEWAY
DALLAS, TEXAS 75207
TELEPHONE: 1-800-644-7976

Prior to installation the Design-Build Team shall submit to the Engineer:

1. FHWA acceptance letter for each impact attenuator unit certifying it meets the requirements of NCHRP Report 350, Test Level 3, in accordance with Section 106-2 of the 2012 *Standard Specifications for Roads and Structures*.
2. Certified working drawings and assembling instructions from the manufacturer for each impact attenuator unit in accordance with Section 105-2 of the 2012 *Standard Specifications for Roads and Structures*.

No modifications shall be made to the impact attenuator unit without the express written permission from the manufacturer. Perform installation in accordance with the details in the plans, and details and assembling instructions furnished by the manufacturer.

Construction Methods

If the median width is 40 feet or less, the Design-Build Team shall supply one of the NON-GATING Impact Attenuator Units listed in the Materials Section herein.

If the median width is greater than 40 feet, the Design-Build Team may use any of the GATING or NON-GATING Impact Attenuator Units listed in the Materials Section herein.

PREFORMED SCOUR HOLE WITH LEVEL SPREADER APRON

(08-24-09)

DB8 R105

Description

Construct and maintain preformed scour holes with spreader aprons at the locations shown on the plans and in accordance with the details in the plans. Work includes excavation, shaping and maintaining the hole and apron, furnishing and placing filter fabric, rip rap (class as specified in the plans) and permanent soil reinforcement matting.

Materials

Item	Section
Plain rip rap	1042
Filter Fabric	1056

The permanent soil reinforcement matting shall be permanent erosion control reinforcement mat and shall be constructed of synthetic or a combination of coconut and synthetic fibers evenly distributed throughout the mat between a bottom UV stabilized netting and a heavy duty UV stabilized top net. The matting shall be stitched together with UV stabilized polypropylene thread to form a permanent three dimensional structure. The mat shall have the following minimum physical properties:

Property	Test Method	Value Unit
Light Penetration	ASTM D6567	9 %
Thickness	ASTM D6525	0.40 in
Mass Per Unit Area	ASTM D6566	0.55 lb/sy
Tensile Strength	ASTM D6818	385 lb/ft
Elongation (Maximum)	ASTM D6818	49 %
Resiliency	ASTM D1777	>70 %
UV Stability *	ASTM 4355	≥80 %
Porosity (Permanent Net)	ECTC Guidelines	≥85 %
Maximum Permissible Shear Stress (Vegetated)	Performance Bench Test	≥8.0 lb/ft ²
Maximum Allowable Velocity (Vegetated)	Performance Bench Test	≥16.0 ft/s

*ASTM D1682 Tensile Strength and % strength retention of material after 1000 hours of exposure.

A certification (Type 1, 2, or 3) from the manufacturer showing:

- (A) the chemical and physical properties of the mat used, and
- (B) conformance of the mat with this specification will be required.

Construction Methods

All areas to be protected with the mat shall be brought to final grade and seeded in accordance with Section 1660 of the 2012 *Standard Specifications for Roads and Structures*. The surface of the soil shall be smooth, firm, stable and free of rocks, clods, roots or other obstructions that would prevent the mat from lying in direct contact with the soil surface. Areas where the mat is to be placed will not need to be mulched.

SUBSURFACE DRAINAGE

(9-1-11)

DB8 R05

Revise the 2012 *Standard Specifications for Roads and Structures* as follows:

Page 8-11, Article 815-1, Delete the first sentence and replace with the following:

The Design-Build Team shall construct subsurface drains, underdrains, blind drains and other types of drains where groundwater is within 6 feet of subgrade.

STREET SIGNS AND MARKERS AND ROUTE MARKERS

(7-1-95)

DB9 R01

Move any existing street signs, markers, and route markers out of the construction limits of the project and install the street signs and markers and route markers so that they will be visible to the traveling public if there is sufficient right of way for these signs and markers outside of the construction limits.

Near the completion of the project and when so directed by the Engineer, move the signs and markers and install them in their proper location in regard to the finished pavement of the project.

Stockpile any signs or markers that cannot be relocated due to lack of right of way, or any signs and markers that will no longer be applicable after the construction of the project, at locations directed by the Engineer for removal by others.

The Design-Build Team shall be responsible to the owners for any damage to any street signs and markers or route markers during the above described operations.

TEMPORARY SHORING

(9-1-11)

DB11 R002

Description

Temporary shoring includes cantilever, braced and anchored shoring and temporary mechanically stabilized earth (MSE) walls. Temporary shoring does not include trench boxes. At the Design-Build Team's option, use any type of temporary shoring. In addition, the Design-Build Team may elect to consider the use of standard shoring where appropriate. In such case, the Standard Shoring Project Special Provision, standard shoring selection forms, and Standard Temporary Shoring Drawings No. 1801.01 and/or 1801.02 will apply. The Standard Shoring provision can be found at:

www.ncdot.org/doh/preconstruct/highway/geotech/provnote/2012/

and the standard shoring selection forms and aforementioned drawings may be found at:

www.ncdot.org/doh/preconstruct/highway/geotech/formdet/2012/

Design and construct temporary shoring based on actual elevations and shoring dimensions in accordance with the contract and accepted submittals. Construct temporary shoring at locations shown in the plans developed by the Design-Build Team. Temporary shoring is required to maintain traffic when a 2:1 (H:V) slope from the top of an embankment or bottom of an excavation will intersect the existing ground line less than 5 feet from the edge of pavement of an open travelway. This provision does not apply to pipe, inlet or utility installation unless noted otherwise in the plans.

Positive protection includes concrete barrier and temporary guardrail. Provide positive protection for temporary shoring at locations shown in the plans and as directed. Positive protection is required if temporary shoring is located in the clear zone in accordance with the *AASHTO Roadside Design Guide*.

(A) Cantilever and Braced Shoring

Cantilever shoring consists of steel sheet piles or H-piles with timber lagging. Braced shoring consists of sheet piles or H-piles with timber lagging and bracing such as beams, plates, walers, struts, rakers, etc. Define "piles" as sheet piles or H-piles.

(B) Anchored Shoring

Anchored shoring consists of sheet piles with walers or H-piles with timber lagging anchored with ground or helical anchors. Driven anchors may be accepted at the discretion of the Engineer. A ground anchor consists of a grouted steel bar or multi-strand tendon with an anchorage. A helical anchor consists of a lead section with a central steel shaft and at least one helix steel plate followed by extensions with only central shafts (no helixes) and an anchorage. Anchorages consist of steel bearing plates with washers and hex nuts for bars or steel wedge plates and wedges for strands. Define "anchors" as ground, helical or driven anchors. Use a prequalified Anchored Wall Contractor to install anchors.

(C) Temporary MSE Walls

Temporary MSE walls include temporary geosynthetic and wire walls. Define “temporary wall” as a temporary MSE wall. Define “reinforcement” as geotextile, geogrid, welded wire grid or metallic strip reinforcement.

Temporary geosynthetic walls consist of geotextile or geogrid reinforcement wrapped behind welded wire facing. Define “temporary geotextile wall” as a temporary geosynthetic wall with geotextile reinforcement and “temporary geogrid wall” as a temporary geosynthetic wall with geogrid reinforcement.

Temporary wire walls consist of welded wire grid or metallic strip reinforcement connected to welded wire facing. Define “Wire Wall Vendor” as the vendor supplying the temporary wire wall.

(D) Embedment

Define “embedment” for cantilever, braced and anchored shoring as the pile depth below the grade in front of shoring. Define “embedment” for temporary walls as the wall height below the grade in front of walls.

(E) Positive Protection

Define “unanchored or anchored portable concrete barrier” as portable concrete barrier (PCB) that meets *Roadway Standard Drawings* No. 1170.01. Define “concrete barrier” as unanchored or anchored PCB or an approved equal. Define “temporary guardrail” as temporary steel beam guardrail that meets *Roadway Standard Drawings* No. 862.02.

Materials

Refer to the 2012 *Standard Specifications for Roads and Structures*.

Item	Section
Anchor Pins	1056-2
Concrete Barrier Materials	1170-2
Flowable Fill, Excavatable	1000-6
Geotextiles	1056
Neat Cement Grout	1003
Portland Cement Concrete	1000
Select Material	1016
Steel Beam Guardrail Materials	862-2
Steel Sheet Piles and H-Piles	1084
Untreated Timber	1082-2
Welded Wire Reinforcement	1070-3
Wire Staples	1060-8(D)

Provide Type 6 material certifications for shoring materials. Use Class IV select material (standard size No. ABC) for temporary guardrail.

For drilled-in H-piles, use nonshrink neat cement grout or Class A concrete that meets Article

1000-4 of the 2012 *Standard Specifications for Roads and Structures* except as modified herein. Provide concrete with a slump of 6" to 8". Use an approved high-range water reducer to achieve this slump.

Use untreated timber with a thickness of at least 3" and a bending stress of at least 1,000 psi for timber lagging. Provide steel bracing that meets ASTM A36.

(A) Shoring Backfill

Use Class II, Type 1, Class III, Class V or Class VI select material or material that meets AASHTO M 145 for soil classification A-2-4 with a maximum PI of 6 for shoring backfill except do not use A-2-4 soil for backfill around culverts.

(B) Anchors

Store anchor materials on blocking a minimum of 12" above the ground and protect it at all times from damage; and when placing in the work make sure it is free from dirt, dust, loose mill scale, loose rust, paint, oil or other foreign materials. Load, transport, unload and store anchor materials such that they are kept clean and free of damage. Damaged or deformed materials will be rejected.

(1) Ground Anchors

Use high-strength steel bars that meet AASHTO M 275 or seven-wire strands that meet ASTM A886 or Article 1070-5 of the 2012 *Standard Specifications for Roads and Structures*. Splice bars in accordance with Article 1070-9 of the 2012 *Standard Specifications for Roads and Structures*. Do not splice strands.

Provide bondbreakers, spacers and centralizers that meet Article 6.3.5 of the *AASHTO LRFD Bridge Construction Specifications*. Use neat cement grout for ground anchors.

(2) Helical Anchors

Use helical anchors with an ICC Evaluation Service, Inc. (ICC-ES) report. Helical anchors without an ICC-ES report may be approved at the discretion of the Engineer. Provide couplers, thread bar adapters and bolts recommended by the Anchor Manufacturer to connect helical anchors together and to piles.

(3) Anchorages

Provide bearing plates that meet Article 6.3.3 of the *AASHTO LRFD Bridge Construction Specifications* and washers, hex nuts, wedge plates and wedges recommended by the Anchor Manufacturer.

(C) Temporary Walls**(1) Welded Wire Facing**

Use welded wire reinforcement for welded wire facing, struts and wires. For temporary wire walls, provide welded wire facing supplied by the Wire Wall Vendor or a manufacturer approved or licensed by the vendor. For temporary wire walls with separate reinforcement and facing components, provide connectors (e.g., bars, clamps, plates, etc.) and fasteners (e.g., bolts, nuts, washers, etc.) required by the Wire Wall Vendor.

(2) Geotextiles

Provide Type 2 geotextile for separation and retention geotextiles. Provide Type 5 geotextile for geotextile reinforcement with wide width tensile strengths at ultimate in accordance with the accepted submittals.

(3) Geogrid Reinforcement

Handle and store geogrids in accordance with Article 1056-2 of the 2012 *Standard Specifications for Roads and Structures*. Define “machine direction” (MD) and “cross-machine direction” (CD) for geogrids in accordance with ASTM D4439. Provide geogrids for geogrid reinforcement with short-term design strengths in accordance with the accepted submittals.

Use geogrids with a roll width of at least 4 feet and an “approved” or “approved for provisional use” status code. Geogrids are approved for short-term design strengths for a 3-year design life in the MD and CD based on material type. The list of approved geogrids with short-term design strengths is available from:

www.ncdot.org/doh/operations/materials/soils/gep.html

Define material type from the website above for shoring backfill as follows:

Material Type	Shoring Backfill
Borrow	A-2-4 Soil
Fine Aggregate	Class II, Type 1 or Class III Select Material
Coarse Aggregate	Class V or VI Select Material

If an approved geogrid does not list a short-term design strength in the MD for the shoring backfill used, do not use the geogrid for geogrid reinforcement. If an approved geogrid does not list a short-term design strength in the CD for the shoring backfill used, do not install the geogrid with the MD parallel to the wall face.

(4) **Welded Wire Grid and Metallic Strip Reinforcement**

Provide welded wire grid and metallic strip reinforcement supplied by the Wire Wall Vendor or a manufacturer approved or licensed by the vendor. Use welded wire grid reinforcement (“mesh”, “mats” and “ladders”) that meet Article 1070-3 of the 2012 *Standard Specifications for Roads and Structures* and metallic strip reinforcement (“straps”) that meet ASTM A572 or A1011.

Preconstruction Requirements

(A) **Concrete Barrier**

Define “clear distance” behind concrete barrier as the horizontal distance between the barrier and edge of pavement. The minimum required clear distance for concrete barrier is shown in the plans. At the Design-Build Team’s option or if the minimum required clear distance is not available, set concrete barrier next to and up against traffic side of temporary shoring except for barrier above temporary walls. Concrete barrier with the minimum required clear distance is required above temporary walls.

(B) **Temporary Guardrail**

Define “clear distance” behind temporary guardrail as the horizontal distance between guardrail posts and temporary shoring. At the Design-Build Team’s option or if clear distance for cantilever, braced and anchored shoring is less than 4 feet, attach guardrail to traffic side of shoring as shown in the plans. Place ABC in clear distance and around guardrail posts instead of pavement. Do not use temporary guardrail above temporary walls.

(C) **Temporary Shoring Designs**

Before beginning temporary shoring design, survey existing ground elevations in the vicinity of shoring locations to determine actual design heights (H). Submit 8 copies of working drawings and 3 copies of design calculations and a PDF copy of each for temporary shoring designs in accordance with Article 105-2 of the 2012 *Standard Specifications for Roads and Structures*. Submit working drawings showing plan views, shoring profiles, typical sections and details of temporary shoring design and construction sequence. Do not begin shoring construction until a design submittal is accepted.

Have cantilever and braced shoring designed, detailed and sealed by an engineer licensed in the state of North Carolina. Use a prequalified Anchored Wall Design Consultant to design anchored shoring. Provide anchored shoring designs sealed by a Design Engineer approved as a Geotechnical Engineer (key person) for an Anchored Wall Design Consultant. Include details in anchored shoring working drawings of anchor locations and lock-off loads, unit grout/ground bond strengths for ground anchors or minimum installation torque and torsional strength rating for helical anchors and if necessary, obstructions extending through shoring or interfering with anchors. Include details in the anchored shoring construction sequence of pile and anchor installation, excavation and

anchor testing.

Use a prequalified MSE Wall Design Consultant to design temporary walls. Provide temporary wall designs sealed by a Design Engineer approved as a Geotechnical Engineer (key person) for the MSE Wall Design Consultant. Include details in temporary wall working drawings of geotextile and reinforcement types, locations and directions and obstructions extending through walls or interfering with reinforcement.

(1) Soil Parameters

Design temporary shoring for the assumed soil parameters and groundwater elevations shown in the plans. Assume the following soil parameters for shoring backfill:

(a) Unit weight (γ) = 120 lb/cf;

(b)

Friction Angle (Φ)	Shoring Backfill
30°	A-2-4 Soil
34°	Class II, Type 1 or Class III Select Material
38°	Class V or VI Select Material

(c) Cohesion (c) = 0 lb/sf.

(2) Traffic Surcharge

Design temporary shoring for a traffic surcharge of 250 lb/sf if traffic will be above and within H of shoring. This traffic surcharge does not apply to construction traffic. Design temporary shoring for any construction surcharge if construction traffic will be above and within H of shoring. For LRFD shoring designs, apply traffic (live load) surcharge in accordance with Figure C11.5.5-3 of the *AASHTO LRFD Bridge Design Specifications*.

(3) Cantilever, Braced and Anchored Shoring Designs

Use shoring backfill for fill sections and voids between cantilever, braced and anchored shoring and the critical failure surface. Use grout or concrete for embedded portions of drilled-in H-piles. Do not use drilled-in sheet piles.

Define “top of shoring” for cantilever, braced and anchored shoring as where the grade intersects the back of sheet piles or H-piles and timber lagging. Design cantilever, braced and anchored shoring for a traffic impact load of 2,000 lb/ft applied 18" above top of shoring if concrete barrier is above and next to shoring or temporary guardrail is above and attached to shoring. For anchored shoring designs, apply traffic impact load as horizontal load (P_{HI}) in accordance with Figure 3.11.6.3-2(a) of the *AASHTO LRFD specifications*.

Extend cantilever, braced and anchored shoring at least 32" above top of shoring

if shoring is designed for traffic impact. Otherwise, extend shoring at least 6" above top of shoring.

Design cantilever, braced and anchored shoring for a maximum deflection of 3" if the horizontal distance to the closest edge of pavement or structure is less than H. Otherwise, design shoring for a maximum deflection of 6". Design cantilever and braced shoring in accordance with the plans and *AASHTO Guide Design Specifications for Bridge Temporary Works*.

Design anchored shoring in accordance with the plans and Article 11.9 of the *AASHTO LRFD Bridge Design Specifications*. Use a resistance factor of 0.80 for tensile resistance of anchors with bars, strands or shafts. Extend the unbonded length for ground anchors and the shallowest helix for helical anchors at least 5 feet behind the critical failure surface. Do not extend anchors beyond right-of-way or easement limits. If existing or future obstructions such as foundations, guardrail posts, pavements, pipes, inlets or utilities will interfere with anchors, maintain a clearance of at least 6" between obstructions and anchors.

(4) Temporary Wall Designs

Use shoring backfill in the reinforced zone of temporary walls. Separation geotextiles are required between shoring backfill and backfill, natural ground or culverts along the sides of the reinforced zone perpendicular to the wall face. For Class V or VI select material in the reinforced zone, separation geotextiles are also required between shoring backfill and backfill or natural ground on top of and at the back of the reinforced zone.

Design temporary walls in accordance with the plans and Article 11.10 of the *AASHTO LRFD Bridge Design Specifications*. Embed temporary walls at least 18" except for walls on structures or rock as determined by the Engineer. Use a uniform reinforcement length throughout the wall height of at least 0.7H or 6 feet, whichever is greater. Extend the reinforced zone at least 6" beyond end of reinforcement. Do not locate the reinforced zone outside right-of-way or easement limits.

Use the simplified method for determining maximum reinforcement loads in accordance with the AASHTO LRFD specifications. For geotextile reinforcement, use geotextile properties approved by the Department or default values in accordance with the AASHTO LRFD specifications. For geogrid reinforcement, use approved geogrid properties available from the website shown elsewhere in this provision. Use geosynthetic properties for the direction reinforcement will be installed, a 3-year design life and the shoring backfill type in the reinforced zone.

Do not use more than 4 different reinforcement strengths for each temporary geosynthetic wall. Design temporary geotextile walls for a reinforcement coverage ratio (R_c) of 1.0 and temporary geogrid walls for an R_c of at least 0.8.

For geogrid reinforcement with an R_c of less than 1.0, use a maximum horizontal clearance between geogrids of 3 feet and stagger reinforcement so geogrids are centered over gaps in the reinforcement layer below.

For temporary geosynthetic walls, use “L” shaped welded wire facing with 18" to 24" long legs. Locate geotextile or geogrid reinforcement so reinforcement layers are at the same level as the horizontal legs of welded wire facing. Use vertical reinforcement spacing equal to facing height. Wrap geotextile or geogrid reinforcement behind welded wire facing and extend reinforcement at least 3 feet back behind facing into shoring backfill.

For temporary wire walls with separate reinforcement and facing components, attach welded wire grid or metallic strip reinforcement to welded wire facing with a connection approved by the Department. For temporary geogrid and wire walls, retain shoring backfill at welded wire facing with retention geotextiles and extend geotextiles at least 3 feet back behind facing into backfill.

(D) Preconstruction Meeting

The Engineer may require a shoring preconstruction meeting to discuss the construction, inspection and testing of the temporary shoring. If required, schedule this meeting after all shoring submittals have been accepted. The Resident, District or Bridge Maintenance Engineer, Bridge or Roadway Construction Engineer, Geotechnical Operations Engineer, Contractor and Shoring Contractor Superintendent will attend this preconstruction meeting.

Construction Methods

Control drainage during construction in the vicinity of shoring. Direct run off away from shoring and shoring backfill. Contain and maintain backfill and protect material from erosion.

Install positive protection in accordance with the contract and accepted submittals. Use PCB in accordance with Section 1170 of the 2012 *Standard Specifications for Roads and Structures* and Standard Drawing No. 1170.01. Use temporary guardrail in accordance with Section 862 of the 2012 *Standard Specifications for Roads and Structures* and Standard Drawing No. 862.01, 862.02 and 862.03.

(A) Tolerances

Construct shoring with the following tolerances:

- (1) Horizontal wires of welded wire facing are level in all directions,
- (2) Shoring location is within 6" of horizontal and vertical alignment shown in the accepted submittals, and
- (3) Shoring plumbness (batter) is within 2° of vertical.

(B) Cantilever, Braced and Anchored Shoring Installation

If overexcavation behind cantilever, braced or anchored shoring is shown in the accepted submittals, excavate before installing piles. Otherwise, install piles before excavating for shoring. Install cantilever, braced or anchored shoring in accordance with the construction sequence shown in the accepted submittals. Remove piles and if applicable, timber lagging when shoring is no longer needed.

(1) Pile Installation

Install piles with the minimum required embedment and extension in accordance with Subarticles 450-3(D) and 450-3(E) of the 2012 *Standard Specifications for Roads and Structures* except that a pile driving equipment data form is not required. Piles may be installed with a vibratory hammer as approved by the Engineer.

Do not splice sheet piles. Use pile excavation to install drilled-in H-piles. After filling holes with grout or concrete to the elevations shown in the accepted submittals, remove any fluids and fill remaining portions of holes with flowable fill. Cure grout or concrete at least 7 days before excavating.

Notify the Engineer if refusal is reached before pile excavation or driven piles attain the minimum required embedment. When this occurs, a revised design submittal may be required.

(2) Excavation

Excavate in front of piles from the top down in accordance with the accepted submittals. For H-piles with timber lagging and braced and anchored shoring, excavate in staged horizontal lifts with a maximum height of 5 feet. Remove flowable fill and material in between H-piles as needed to install timber lagging. Position lagging with at least 3" of contact in the horizontal direction between the lagging and pile flanges. Do not excavate the next lift until timber lagging for the current lift is installed and if applicable, bracing and anchors for the current lift are accepted. Backfill behind cantilever, braced or anchored shoring with shoring backfill.

(3) Anchor Installation

If applicable, install foundations located behind anchored shoring before installing anchors. Fabricate and install ground anchors in accordance with the accepted submittals, Articles 6.4 and 6.5 of the *AASHTO LRFD Bridge Construction Specifications* and the following unless otherwise approved:

- (a) Materials in accordance with this provision are required instead of materials conforming to Articles 6.4 and 6.5.3 of the *AASHTO LRFD Specifications*,

- (b) Encapsulation-protected ground anchors in accordance with Article 6.4.1.2 of the AASHTO LRFD specifications are not required, and
- (c) Corrosion protection for unbonded lengths of ground anchors and anchorage covers are not required.

Install helical anchors in accordance with the accepted submittals and Anchor Manufacturer's instructions. Measure torque during installation and do not exceed the torsional strength rating of the helical anchor. Attain the minimum required installation torque and penetration before terminating anchor installation. When replacing a helical anchor, embed last helix of the replacement anchor at least 3 helix plate diameters past the location of the first helix of the previous anchor.

(4) Anchor Testing

Proof test and lock-off anchors in accordance with the accepted submittals and Article 6.5.5 of the *AASHTO LRFD Bridge Construction Specifications* except for the acceptance criteria in Article 6.5.5.5. For the AASHTO LRFD specifications, "ground anchor" refers to a ground or helical anchor and "tendon" refers to a bar, strand or shaft.

(a) Anchor Acceptance

Anchor acceptance is based in part on the following criteria.

- (i) For ground and helical anchors, total movement is less than 0.04" between the 1 and 10 minute readings or less than 0.08" between the 6 and 60 minute readings.
- (ii) For ground anchors, total movement at maximum test load exceeds 80% of the theoretical elastic elongation of the unbonded length.

(b) Anchor Test Results

Submit 2 copies of anchor test records including movement versus load plots for each load increment within 24 hours of completing each row of anchors. The Engineer will review the test records to determine if the anchors are acceptable.

If the Engineer determines an anchor is unacceptable, revise the anchor design or installation methods. Submit a revised anchored shoring design for acceptance and provide an acceptable anchor with the revised design or installation methods. If required, replace the anchor or provide additional anchors with the revised design or installation methods.

(C) Temporary Wall Installation

Excavate as necessary for temporary walls in accordance with the plans and accepted submittals. If applicable, install foundations located in the reinforced zone before placing shoring backfill or reinforcement unless otherwise approved. Notify the Engineer when foundation excavation is complete. Do not place shoring backfill or reinforcement until excavation dimensions and foundation material are approved.

Erect welded wire facing with no negative batter (wall face leaning forward) so the wall position is as shown in the plans and accepted submittals. Set welded wire facing adjacent to each other in the horizontal and vertical direction to completely cover the wall face with facing. Stagger welded wire facing to create a running bond by centering facing over joints in the row below.

Wrap geotextile reinforcement and retention geotextiles behind welded wire facing as shown in the plans and accepted submittals and cover geotextiles with at least 3" of shoring backfill. Overlap adjacent geotextile reinforcement and retention and separation geotextiles at least 18" with seams oriented perpendicular to the wall face. Hold geotextiles in place with wire staples or anchor pins as needed.

Place reinforcement within 3" of locations shown in the plans and accepted submittals and in slight tension free of kinks, folds, wrinkles or creases. Install reinforcement with the direction shown in the plans and accepted submittals. For temporary wire walls with separate reinforcement and facing components, attach welded wire grid or metallic strip reinforcement to welded wire facing as shown in the accepted submittals. Do not splice or overlap reinforcement so seams are parallel to the wall face. Contact the Engineer when unanticipated existing or future obstructions such as foundations, pavements, pipes, inlets or utilities will interfere with reinforcement.

Place shoring backfill in the reinforced zone in 8" to 10" thick lifts. Compact A-2-4 soil and Class II, Type 1 and Class III select material in accordance with Subarticle 235-3(C) of the 2012 *Standard Specifications for Roads and Structures*. Use only hand operated compaction equipment to compact backfill within 3 feet of welded wire facing. At a distance greater than 3 feet, compact shoring backfill with at least 4 passes of an 8 ton to 10 ton vibratory roller in a direction parallel to the wall face. Smooth wheeled or rubber tired rollers are also acceptable for compacting backfill. Do not use sheepsfoot, grid rollers or other types of compaction equipment with feet. Do not displace or damage reinforcement when placing and compacting shoring backfill. End dumping directly on geotextile or geogrid reinforcement is not permitted. Do not operate heavy equipment on reinforcement until it is covered with at least 8" of shoring backfill. Replace any damaged reinforcement to the satisfaction of the Engineer.

Backfill for temporary walls outside the reinforced zone in accordance with Article 410-8 of the 2012 *Standard Specifications for Roads and Structures*. Bench temporary walls into the sides of excavations where applicable. For temporary geosynthetic walls with top of wall within 5 feet of finished grade, remove top facing and incorporate top reinforcement layer into fill when placing fill in front of wall. Temporary walls remain in place permanently unless otherwise required.

COORDINATION OF LIGHTING WORK

(04-03-07)

DB14 R01

Complete the required work as described in the "Lighting" Plans and Specifications, so that lighting is maintained for all areas shown on the plans by either the existing or the proposed lights.

Use care in working around the lights and circuitry and phase operations so that the lighting systems will not be disrupted. Make repairs or replacements in conformance with the "Lighting" Special Provisions. Should the Design-Build Team fail to make such repairs within the time frame allowed, the Department will cause the necessary repairs to be made by others.

ON-THE-JOB TRAINING

(10-16-07) (Rev. 06-03-09)

Z-10

Description

The North Carolina Department of Transportation will administer a custom version of the Federal On-the-Job Training (OJT) Program, commonly referred to as the Alternate OJT Program. All contractors (existing and newcomers) will be automatically placed in the Alternate Program. Standard OJT requirements typically associated with individual projects will no longer be applied at the project level. Instead, these requirements will be applicable on an annual basis for each contractor administered by the OJT Program Manager.

On the Job Training shall meet the requirements of 23 CFR 230.107 (b), 23 USC – Section 140, this provision and the On-the-Job Training Program Manual.

The Alternate OJT Program will allow a contractor to train employees on Federal, State and privately funded projects located in North Carolina. However, priority must be given to training employees on NCDOT Federal-Aid funded projects.

Minorities and Women

Developing, training and upgrading of minorities and women toward journeymen level status is a primary objective of this special training provision. Accordingly, the Contractor shall make every effort to enroll minority and women as trainees to the extent that such persons are available within a reasonable area of recruitment. This training commitment is not intended, and shall not be used, to discriminate against any applicant for training, whether a member of a minority group or not.

Assessing Training Goals

The Department through the OJT Program Manager, will assign training goals for a calendar year based on the contractors' past three years' activity and the contractors' anticipated upcoming year's activity with the Department. At the beginning of each year, all contractors eligible will be contacted by the Department to determine the number of trainees that will be

assigned for the upcoming calendar year. At that time, the Contractor shall enter into an agreement with the Department to provide a self-imposed on-the-job training program for the calendar year. This agreement will include a specific number of annual training goals agreed to by both parties. The number of training assignments may range from 1 to 15 per contractor per calendar year. The Contractor shall sign an agreement to fulfill their annual goal for the year. A sample agreement is available at www.ncdot.org/business/ocs/ojt/.

Training Classifications

The Contractor shall provide on-the-job training aimed at developing full journeyman level workers in the construction craft / operator positions. Preference shall be given to providing training in the following skilled work classifications:

Equipment Operators	Office Engineers
Truck Drivers	Estimators
Carpenters	Iron / Reinforcing Steel Workers
Concrete Finishers	Mechanics
Pipe Layers	Welders

The Department has established common training classifications and their respective training requirements that may be used by the contractors. However, the classifications established are not all-inclusive. Where the training is oriented toward construction applications, training will be allowed in lower-level management positions such as office engineers and estimators. Contractors shall submit new classifications for specific job functions that their employees are performing. The Department will review and recommend for acceptance to FHWA the new classifications proposed by contractors, if applicable. New classifications shall meet the following requirements:

Proposed training classifications are reasonable and realistic based on the job skill classification needs, and

The number of training hours specified in the training classification is consistent with common practices and provides enough time for the trainee to obtain journeyman level status.

The Contractor may allow trainees to be trained by a subcontractor provided that the Contractor retains primary responsibility for meeting the training and this provision is made applicable to the subcontract. However, only the Contractor will receive credit towards the annual goal for the trainee.

Where feasible, 25 percent of apprentices or trainees in each occupation shall be in their first year of apprenticeship or training. The number of trainees shall be distributed among the work classifications on the basis of the contractor's needs and the availability of journeymen in the various classifications within a reasonable area of recruitment.

No employee shall be employed as a trainee in any classification in which they have successfully completed a training course leading to journeyman level status or in which they have been employed as a journeyman.

Records and Reports

The Contractor shall maintain enrollment, monthly and completion reports documenting company compliance under these contract documents. These documents and any other information, as requested, shall be submitted to the OJT Program Manager.

Upon completion and graduation of the program, the Contractor shall provide each trainee with a certification Certificate showing the type and length of training satisfactorily completed.

Trainee Interviews

All trainees enrolled in the program shall receive an initial and Trainee / Post graduate interview conducted by the OJT program staff.

Trainee Wages

Contractors shall compensate trainees on a graduating pay scale based upon a percentage of the prevailing minimum journeyman wages (Davis-Bacon Act). Minimum pay shall be as follows:

60 percent	of the journeyman wage for the first half of the training period
75 percent	of the journeyman wage for the third quarter of the training period
90 percent	of the journeyman wage for the last quarter of the training period

In no instance shall a trainee be paid less than the local minimum wage. The Contractor shall adhere to the minimum hourly wage rate that will satisfy both the NCDOL and the Department.

Achieving or Failing to Meet Training Goals

The Contractor will be credited for each trainee employed by him on the contract work who is currently enrolled or becomes enrolled in an approved program and who receives training for at least 50 percent of the specific program requirement. Trainees will be allowed to be transferred between projects if required by the Contractor's scheduled workload to meet training goals.

If a contractor fails to attain their training assignments for the calendar year, they may be taken off the NCDOT's Bidders List.

Measurement and Payment

No compensation will be made for providing required training in accordance with these contract documents.

STANDARD SPECIAL PROVISION**AVAILABILITY OF FUNDS – TERMINATION OF CONTRACTS**

(9-1-11)

Z-2

General Statute 143C-6-11. (h) Highway Appropriation is hereby incorporated verbatim in this contract as follows:

“(h) Amounts Encumbered – Transportation project appropriations may be encumbered in the amount of allotments made to the Department of Transportation by the Director for the estimated payments for transportation project contract work to be performed in the appropriation fiscal year. The allotments shall be multiyear allotments and shall be based on estimated revenues and shall be subject to the maximum contract authority contained in *General Statute 143C-6-11(c)*. Payment for transportation project work performed pursuant to contract in any fiscal year other than the current fiscal year is subject to appropriations by the General Assembly. Transportation project contracts shall contain a schedule of estimated completion progress, and any acceleration of this progress shall be subject to the approval of the Department of Transportation provided funds are available. The State reserves the right to terminate or suspend any transportation project contract, and any transportation project contract shall be so terminated or suspended if funds will not be available for payment of the work to be performed during that fiscal year pursuant to the contract. In the event of termination of any contract, the contractor shall be given a written notice of termination at least 60 days before completion of scheduled work for which funds are available. In the event of termination, the contractor shall be paid for the work already performed in accordance with the contract specifications.”

Payment will be made on any contract terminated pursuant to the special provision in accordance with Article 108-13(E), of the *North Carolina Department of Transportation Standard Specifications for Roads and Structures*, dated January 2012 and as amended by the Standard Special Provision, Division One found elsewhere in this RFP.

***** STANDARD SPECIAL PROVISIONS *****

NCDOT GENERAL SEED SPECIFICATIONS FOR SEED QUALITY

(5-7-11)

Z-3

Seed shall be sampled and tested by the North Carolina Department of Agriculture and Consumer Services, Seed Testing Laboratory. When said samples are collected, the vendor shall supply an independent laboratory report for each lot to be tested. Results from seed so sampled shall be final. Seed not meeting the specifications shall be rejected by the Department of Transportation and shall not be delivered to North Carolina Department of Transportation warehouses. If seed has been delivered it shall be available for pickup and replacement at the supplier's expense.

Any re-labeling required by the North Carolina Department of Agriculture and Consumer Services, Seed Testing Laboratory, that would cause the label to reflect as otherwise specified herein shall be rejected by the North Carolina Department of Transportation.

Seed shall be free from seeds of the noxious weeds Johnsongrass, Balloonvine, Jimsonweed, Witchweed, Itchgrass, Serrated Tussock, Showy Crotalaria, Smooth Crotalaria, Sicklepod, Sandbur, Wild Onion, and Wild Garlic. Seed shall not be labeled with the above weed species on the seed analysis label. Tolerances as applied by the Association of Official Seed Analysts will NOT be allowed for the above noxious weeds except for Wild Onion and Wild Garlic.

Tolerances established by the Association of Official Seed Analysts will generally be recognized. However, for the purpose of figuring pure live seed, the found pure seed and found germination percentages as reported by the North Carolina Department of Agriculture and Consumer Services, Seed Testing Laboratory will be used. Allowances, as established by the NCDOT, will be recognized for minimum pure live seed as listed on the following pages.

The specifications for restricted noxious weed seed refers to the number per pound as follows:

Restricted Noxious Weed	Limitations per Lb. of Seed	Restricted Noxious Weed	Limitations per Lb. of Seed
Blessed Thistle	4 seeds	Cornflower (Ragged Robin)	27 seeds
Cocklebur	4 seeds	Texas Panicum	27 seeds
Spurred Anoda	4 seeds	Bracted Plantain	54 seeds
Velvetleaf	4 seeds	Buckhorn Plantain	54 seeds
Morning-glory	8 seeds	Broadleaf Dock	54 seeds
Corn Cockle	10 seeds	Curly Dock	54 seeds
Wild Radish	12 seeds	Dodder	54 seeds
Purple Nutsedge	27 seeds	Giant Foxtail	54 seeds
Yellow Nutsedge	27 seeds	Horsenettle	54 seeds
Canada Thistle	27 seeds	Quackgrass	54 seeds
Field Bindweed	27 seeds	Wild Mustard	54 seeds
Hedge Bindweed	27 seeds		

Seed of Pensacola Bahiagrass shall not contain more than 7% inert matter, Kentucky Bluegrass, Centipede and Fine or Hard Fescue shall not contain more than 5% inert matter whereas a maximum of 2% inert matter will be allowed on all other kinds of seed. In addition, all seed shall not contain more than 2% other crop seed nor more than 1% total weed seed. The germination rate as tested by the North Carolina Department of Agriculture shall not fall below 70%, which includes both dormant and hard seed. Seed shall be labeled with not more than 7%, 5% or 2% inert matter (according to above specifications), 2% other crop seed and 1% total weed seed.

Exceptions may be made for minimum pure live seed allowances when cases of seed variety shortages are verified. Pure live seed percentages will be applied in a verified shortage situation. Those purchase orders of deficient seed lots will be credited with the percentage that the seed is deficient.

FURTHER SPECIFICATIONS FOR EACH SEED GROUP ARE GIVEN BELOW:

Minimum 85% pure live seed; maximum 1% total weed seed; maximum 2% total other crop seed; maximum 144 restricted noxious weed seed per pound. Seed less than 83% pure live seed will not be approved.

Sericea Lespedeza
Oats (seeds)

Minimum 80% pure live seed; maximum 1% total weed seed; maximum 2% total other crop; maximum 144 restricted noxious weed seed per pound. Seed less than 78% pure live seed will not be approved.

Tall Fescue (all approved varieties)	Bermudagrass
Kobe Lespedeza	Browntop Millet
Korean Lespedeza	German Millet - Strain R
Weeping Lovegrass	Clover - Red/White/Crimson
Carpetgrass	

Minimum 78% pure live seed; maximum 1% total weed seed; maximum 2% total other crop seed; maximum 144 restricted noxious weed seed per pound. Seed less than 76% pure live seed will not be approved.

Common or Sweet Sundangrass

Minimum 76% pure live seed; maximum 1% total weed seed; maximum 2% total other crop seed; maximum 144 restricted noxious weed seed per pound. Seed less than 74% pure live seed will not be approved.

Rye (grain; all varieties)
Kentucky Bluegrass (all approved varieties)
Hard Fescue (all approved varieties)
Shrub (bicolor) Lespedeza

Minimum 70% pure live seed; maximum 1% total weed seed; maximum 2% total other crop seed; maximum 144 noxious weed seed per pound. Seed less than 70% pure live seed will not be approved.

Centipede grass
Crownvetch
Pensacola Bahiagrass
Creeping Red Fescue

Japanese Millet
Reed Canary Grass
Zoysia

Minimum 70% pure live seed; maximum 1% total weed seed; maximum 2% total other crop seed; maximum 5% inert matter; maximum 144 restricted noxious weed seed per pound.

Barnyard Grass
Big Bluestem
Little Bluestem
Bristly Locust
Birdsfoot Trefoil
Indiangrass
Orchardgrass
Switchgrass
Yellow Blossom Sweet Clover

***** STANDARD SPECIAL PROVISIONS *****

AWARD OF CONTRACT

(6-28-77)

Z-6

“The North Carolina Department of Transportation, in accordance with the provisions of *Title VI of the Civil Rights Act of 1964* (78 Stat. 252) and the Regulations of the Department of Transportation (*49 C.F.R., Part 21*), issued pursuant to such act, hereby notifies all bidders that it will affirmatively insure that the contract entered into pursuant to this advertisement will be awarded to the lowest responsible bidder without discrimination on the ground of race, color, or national origin”.

***** STANDARD SPECIAL PROVISIONS *******MINORITY AND FEMALE EMPLOYMENT REQUIREMENTS**

(12-18-07)

Z-7

NOTICE OF REQUIREMENTS FOR AFFIRMATIVE ACTION TO ENSURE EQUAL EMPLOYMENT OPPORTUNITY (*EXECUTIVE NUMBER 11246*)

1. The goals and timetables for minority and female participation, expressed in percentage terms for the Contractor's aggregate workforce in each trade on all construction work in the covered area, see as shown on the attached sheet entitled "Employment Goals for Minority and Female Participation".

These goals are applicable to all the Contractor's construction work (whether or not it is Federal or federally assisted) performed in the covered area. If the Contractor performs construction work in a geographical area located outside of the covered area, it shall apply the goals established for such geographical area where the work is actually performed. With regard to this second area, the Contractor also is subject to the goals for both its federally involved and nonfederally involved construction.

The Contractor's compliance with the Executive Order and the regulations in *41 CFR Part 60-4* shall be based on its implementation of the Equal Opportunity Clause, specific affirmative action obligations required by the specifications set forth in *41 CFR 60-4.3(a)*, and its effort to meet the goals. The hours of minority and female employment and training must be substantially uniform throughout the length of the contract, and in each trade and the Contractor shall make a good faith effort to employ minorities and women evenly on each of its projects. The transfer of minority or female employees or trainees from Contractor to Contractor or from project to project or the sole purpose of meeting the Contractor's goals shall be a violation of the contract, the executive Order and the regulations in *41 CFR Part 60-4*. Compliance with the goals will be measured against the total work hours performed.

2. As used in this Notice and in the contract resulting from this solicitation, the "covered area" is the county or counties shown on the cover sheet of the proposal form and contract.

**EMPLOYMENT GOALS FOR MINORITY
AND FEMALE PARTICIPATION**

Economic Areas

Area 023 29.7%

Bertie County
Camden County
Chowan County
Gates County
Hertford County
Pasquotank County
Perquimans County

Area 024 31.7%

Beaufort County
Carteret County
Craven County
Dare County
Edgecombe County
Green County
Halifax County
Hyde County
Jones County
Lenoir County
Martin County
Nash County
Northampton County
Pamlico County
Pitt County
Tyrrell County
Washington County
Wayne County
Wilson County

Area 025 23.5%

Columbus County
Duplin County
Onslow County
Pender County

Area 026 33.5%

Bladen County
Hoke County
Richmond County
Robeson County
Sampson County
Scotland County

Area 027 24.7%

Chatham County
Franklin County
Granville County
Harnett County
Johnston County
Lee County
Person County
Vance County
Warren County

Area 028 15.5%

Alleghany County
Ashe County
Caswell County
Davie County
Montgomery County
Moore County
Rockingham County
Surry County
Watauga County
Wilkes County

Area 029 15.7%

Alexander County
Anson County
Burke County
Cabarrus County
Caldwell County
Catawba County
Cleveland County
Iredell County
Lincoln County
Polk County
Rowan County
Rutherford County
Stanly County

Area 0480 8.5%

Buncombe County
Madison County

Area 030 6.3%

Avery County
Cherokee County
Clay County
Graham County
Haywood County
Henderson County
Jackson County
McDowell County
Macon County
Mitchell County
Swain County
Transylvania County
Yancey County

SMSA Areas

Area 5720 26.6%

Currituck County

Area 9200 20.7%

Brunswick County

New Hanover County

Area 2560 24.2%

Cumberland County

Area 6640 22.8%

Durham County

Orange County

Wake County

Area 1300 16.2%

Alamance County

Area 3120 16.4%

Davidson County

Forsyth County

Guilford County

Randolph County

Stokes County

Yadkin County

Area 1520 18.3%

Gaston County

Mecklenburg County

Union County

Goals for Female

Participation in Each Trade

(Statewide) 6.9%

***** STANDARD SPECIAL PROVISIONS *****

REQUIRED CONTRACT PROVISIONS FEDERAL-AID CONSTRUCTION CONTRACTS (FHWA-1273)

- I. General
- II. Nondiscrimination
- III. Nonsegregated Facilities
- IV. Payment of Predetermined Minimum Wage
- V. Statements and Payrolls
- VI. Record of Materials, Supplies, and Labor
- VII. Subletting or Assigning the Contract
- VIII. Safety: Accident Prevention
- IX. False Statements Concerning Highway Projects
- X. Implementation of Clean Air Act and Federal Water Pollution Control Act
- XI. Certification Regarding Debarment, Suspension Ineligibility, and Voluntary Exclusion
- XII. Certification Regarding Use of Contract Funds for Lobbying

I. GENERAL

1. These contract provisions shall apply to all work performed on the contract by the contractor's own organization and with the assistance of workers under the contractor's immediate superintendence and to all work performed on the contract by piecework, station work, or by subcontract.
2. Except as otherwise provided for in each section, the contractor shall insert in each subcontract all of the stipulations contained in these Required Contract Provisions, and further require their inclusion in any lower tier subcontract or purchase order that may in turn be made. The Required Contract Provisions shall not be incorporated by reference in any case. The prime contractor shall be responsible for compliance by any subcontractor or lower tier subcontractor with these Required Contract Provisions.
3. A breach of any of the stipulations contained in these Required Contract Provisions shall be sufficient grounds for termination of the contract.
4. A breach of the following clauses of the Required Contract Provisions may also be grounds for debarment as provided in 29 CFR 5.12:
 - Section I, paragraph 2;
 - Section IV, paragraphs 1, 2, 3, 4, and 7;
 - Section V, paragraphs 1 and 2a through 2g.
5. Disputes arising out of the labor standards provisions of Section IV (except paragraph 5) and Section V of these Required Contract Provisions shall not be subject to the general disputes clause of this contract. Such disputes shall be resolved in accordance with the procedures of the U.S. Department of Labor (DOL) as set forth in 29 CFR 5, 6, and 7. Disputes within the meaning of this clause include disputes between the contractor (or any of its subcontractors) and the contracting agency, the DOL, or the contractor's employees or their representatives.
6. **Selection of Labor:** During the performance of this contract, the contractor shall not:
 - a. discriminate against labor from any other State, possession, or territory of the United States (except for employment preference for Appalachian contracts, when applicable, as specified in Attachment A), or
 - b. employ convict labor for any purpose within the limits of the project unless it is labor performed by convicts who are on parole, supervised release, or probation.

II. NONDISCRIMINATION

(Applicable to all Federal-aid construction contracts and to all related subcontracts of \$10,000 or more.)

1. **Equal Employment Opportunity:** Equal employment opportunity (EEO) requirements not to discriminate and to take affirmative action to assure equal opportunity as set forth under laws, executive orders, rules, regulations (28 CFR 35, 29 CFR 1630 and 41 CFR 60) and orders of the Secretary of Labor as modified by the provisions prescribed herein, and imposed pursuant to 23 U.S.C. 140 shall constitute the EEO and specific affirmative action standards for the contractor's project activities under this contract. The Equal Opportunity Construction Contract Specifications set forth under 41 CFR 60-4.3 and the provisions of the American Disabilities Act of 1990 (42 U.S.C. 12101 *et seq.*) set forth under 28 CFR 35 and 29 CFR 1630 are incorporated by reference in this contract. In the execution of this contract, the contractor agrees to comply with the following minimum specific requirement activities of EEO:
 - a. The contractor will work with the State highway agency (SHA) and the Federal Government in carrying out EEO obligations and in their review of his/her activities under the contract.

- b. The contractor will accept as his operating policy the following statement:
- "It is the policy of this Company to assure that applicants are employed, and that employees are treated during employment, without regard to their race, religion, sex, color, national origin, age or disability. Such action shall include: employment, upgrading, demotion, or transfer; recruitment or recruitment advertising; layoff or termination; rates of pay or other forms of compensation; and selection for training, including apprenticeship, preapprenticeship, and/or on-the-job training."
2. **EEO Officer:** The contractor will designate and make known to the SHA contracting officers an EEO Officer who will have the responsibility for and must be capable of effectively administering and promoting an active contractor program of EEO and who must be assigned adequate authority and responsibility to do so.
3. **Dissemination of Policy:** All members of the contractor's staff who are authorized to hire, supervise, promote, and discharge employees, or who recommend such action, or who are substantially involved in such action, will be made fully cognizant of, and will implement, the contractor's EEO policy and contractual responsibilities to provide EEO in each grade and classification of employment. To ensure that the above agreement will be met, the following actions will be taken as a minimum:
- a. Periodic meetings of supervisory and personnel office employees will be conducted before the start of work and then not less often than once every six months, at which time the contractor's EEO policy and its implementation will be reviewed and explained. The meetings will be conducted by the EEO Officer.
- b. All new supervisory or personnel office employees will be given a thorough indoctrination by the EEO Officer, covering all major aspects of the contractor's EEO obligations within thirty days following their reporting for duty with the contractor.
- c. All personnel who are engaged in direct recruitment for the project will be instructed by the EEO Officer in the contractor's procedures for locating and hiring minority group employees.
- d. Notices and posters setting forth the contractor's EEO policy will be placed in areas readily accessible to employees, applicants for employment and potential employees.
- e. The contractor's EEO policy and the procedures to implement such policy will be brought to the attention of employees by means of meetings, employee handbooks, or other appropriate means.
4. **Recruitment:** When advertising for employees, the contractor will include in all advertisements for employees the notation: "An Equal Opportunity Employer." All such advertisements will be placed in publications having a large circulation among minority groups in the area from which the project work force would normally be derived.
- a. The contractor will, unless precluded by a valid bargaining agreement, conduct systematic and direct recruitment through public and private employee referral sources likely to yield qualified minority group applicants. To meet this requirement, the contractor will identify sources of potential minority group employees, and establish with such identified sources procedures whereby minority group applicants may be referred to the contractor for employment consideration.
- b. In the event the contractor has a valid bargaining agreement providing for exclusive hiring hall referrals, he is expected to observe the provisions of that agreement to the extent that the system permits the contractor's compliance with EEO contract provisions. (The DOL has held that where implementation of such agreements have the effect of discriminating against minorities or women, or obligates the contractor to do the same, such implementation violates Executive Order 11246, as amended.)
- c. The contractor will encourage his present employees to refer minority group applicants for employment. Information and procedures with regard to referring minority group applicants will be discussed with employees.
5. **Personnel Actions:** Wages, working conditions, and employee benefits shall be established and administered, and personnel actions of every type, including hiring, upgrading, promotion, transfer, demotion, layoff, and termination, shall be taken without regard to race, color, religion, sex, national origin, age or disability. The following procedures shall be followed:
- a. The contractor will conduct periodic inspections of project sites to insure that working conditions and employee facilities do not indicate discriminatory treatment of project site personnel.
- b. The contractor will periodically evaluate the spread of wages paid within each classification to determine any evidence of discriminatory wage practices.
- c. The contractor will periodically review selected personnel actions in depth to determine whether there is evidence of discrimination. Where evidence is found, the contractor will promptly take corrective action. If the review indicates that the discrimination may extend beyond the actions reviewed, such corrective action shall include all affected persons.
- d. The contractor will promptly investigate all complaints of alleged discrimination made to the contractor in connection with his obligations under this contract, will attempt to resolve such complaints, and will take appropriate corrective action within a reasonable time. If the investigation indicates that the discrimination may affect persons other than the complainant, such corrective action shall include such other persons. Upon completion of each investigation, the contractor will inform every complainant of all of his avenues of appeal.
6. **Training and Promotion:**
- a. The contractor will assist in locating, qualifying, and increasing the skills of minority group and women employees, and applicants for employment.
- b. Consistent with the contractor's work force requirements and as permissible under Federal and State regulations, the contractor shall make full use of training programs, i.e., apprenticeship, and on-the-job training programs for the geographical area of contract performance. Where feasible, 25 percent of apprentices or trainees in each occupation shall be in their first year of apprenticeship or training. In the event a special provision for training is provided under this contract, this subparagraph will be superseded as indicated in the special provision.

- c. The contractor will advise employees and applicants for employment of available training programs and entrance requirements for each.
 - d. The contractor will periodically review the training and promotion potential of minority group and women employees and will encourage eligible employees to apply for such training and promotion.
7. **Unions:** If the contractor relies in whole or in part upon unions as a source of employees, the contractor will use his/her best efforts to obtain the cooperation of such unions to increase opportunities for minority groups and women within the unions, and to effect referrals by such unions of minority and female employees. Actions by the contractor either directly or through a contractor's association acting as agent will include the procedures set forth below:
- a. The contractor will use best efforts to develop, in cooperation with the unions, joint training programs aimed toward qualifying more minority group members and women for membership in the unions and increasing the skills of minority group employees and women so that they may qualify for higher paying employment.
 - b. The contractor will use best efforts to incorporate an EEO clause into each union agreement to the end that such union will be contractually bound to refer applicants without regard to their race, color, religion, sex, national origin, age or disability.
 - c. The contractor is to obtain information as to the referral practices and policies of the labor union except that to the extent such information is within the exclusive possession of the labor union and such labor union refuses to furnish such information to the contractor, the contractor shall so certify to the SHA and shall set forth what efforts have been made to obtain such information.
 - d. In the event the union is unable to provide the contractor with a reasonable flow of minority and women referrals within the time limit set forth in the collective bargaining agreement, the contractor will, through independent recruitment efforts, fill the employment vacancies without regard to race, color, religion, sex, national origin, age or disability; making full efforts to obtain qualified and/or qualifiable minority group persons and women. (The DOL has held that it shall be no excuse that the union with which the contractor has a collective bargaining agreement providing for exclusive referral failed to refer minority employees.) In the event the union referral practice prevents the contractor from meeting the obligations pursuant to Executive Order 11246, as amended, and these special provisions, such contractor shall immediately notify the SHA.
8. **Selection of Subcontractors, Procurement of Materials and Leasing of Equipment:** The contractor shall not discriminate on the grounds of race, color, religion, sex, national origin, age or disability in the selection and retention of subcontractors, including procurement of materials and leases of equipment.
- a. The contractor shall notify all potential subcontractors and suppliers of his/her EEO obligations under this contract.
 - b. Disadvantaged business enterprises (DBE), as defined in 49 CFR 23, shall have equal opportunity to compete for and perform subcontracts which the contractor enters into pursuant to this contract. The contractor will use his best efforts to solicit bids from and to utilize DBE subcontractors or subcontractors with meaningful minority group and female representation among their employees. Contractors shall obtain lists of DBE construction firms from SHA personnel.
 - c. The contractor will use his best efforts to ensure subcontractor compliance with their EEO obligations.
9. **Records and Reports:** The contractor shall keep such records as necessary to document compliance with the EEO requirements. Such records shall be retained for a period of three years following completion of the contract work and shall be available at reasonable times and places for inspection by authorized representatives of the SHA and the FHWA.
- a. The records kept by the contractor shall document the following:
 - 1. The number of minority and non-minority group members and women employed in each work classification on the project;
 - 2. The progress and efforts being made in cooperation with unions, when applicable, to increase employment opportunities for minorities and women;
 - 3. The progress and efforts being made in locating, hiring, training, qualifying, and upgrading minority and female employees; and
 - 4. The progress and efforts being made in securing the services of DBE subcontractors or subcontractors with meaningful minority and female representation among their employees.
 - b. The contractors will submit an annual report to the SHA each July for the duration of the project, indicating the number of minority, women, and non-minority group employees currently engaged in each work classification required by the contract work. This information is to be reported on Form FHWA-1391. If on-the-job training is being required by special provision, the contractor will be required to collect and report training data.

III. NONSEGREGATED FACILITIES

(Applicable to all Federal-aid construction contracts and to all related subcontracts of \$10,000 or more.)

- a. By submission of this bid, the execution of this contract or subcontract, or the consummation of this material supply agreement or purchase order, as appropriate, the bidder, Federal-aid construction contractor, subcontractor, material supplier, or vendor, as appropriate, certifies that the firm does not maintain or provide for its employees any segregated facilities at any of its establishments, and that the firm does not permit its employees to perform their services at any location, under its control, where segregated facilities are maintained. The firm agrees that a breach of this certification is a violation of the EEO provisions of this contract. The firm further certifies that no employee will be denied access to adequate facilities on the basis of sex or disability.
- b. As used in this certification, the term "segregated facilities" means any waiting rooms, work areas, restrooms and washrooms, restaurants and other eating areas, timeclocks, locker rooms, and other storage or dressing areas, parking lots, drinking fountains, recreation or entertainment areas, transportation, and housing facilities provided for employees which are segregated by explicit directive, or are, in fact, segregated on the basis of race, color, religion, national origin, age or disability, because of habit, local custom, or otherwise. The only exception will be for the disabled when the demands for accessibility override (e.g. disabled parking).

- c. The contractor agrees that it has obtained or will obtain identical certification from proposed subcontractors or material suppliers prior to award of subcontracts or consummation of material supply agreements of \$10,000 or more and that it will retain such certifications in its files.

IV. PAYMENT OF PREDETERMINED MINIMUM WAGE

(Applicable to all Federal-aid construction contracts exceeding \$2,000 and to all related subcontracts, except for projects located on roadways classified as local roads or rural minor collectors, which are exempt.)

1. General:

- a. All mechanics and laborers employed or working upon the site of the work will be paid unconditionally and not less often than once a week and without subsequent deduction or rebate on any account [except such payroll deductions as are permitted by regulations (29 CFR 3) issued by the Secretary of Labor under the Copeland Act (40 U.S.C. 276c)] the full amounts of wages and bona fide fringe benefits (or cash equivalents thereof) due at time of payment. The payment shall be computed at wage rates not less than those contained in the wage determination of the Secretary of Labor (hereinafter "the wage determination") which is attached hereto and made a part hereof, regardless of any contractual relationship which may be alleged to exist between the contractor or its subcontractors and such laborers and mechanics. The wage determination (including any additional classifications and wage rates conformed under paragraph 2 of this Section IV and the DOL poster (WH-1321) or Form FHWA-1495) shall be posted at all times by the contractor and its subcontractors at the site of the work in a prominent and accessible place where it can be easily seen by the workers. For the purpose of this Section, contributions made or costs reasonably anticipated for bona fide fringe benefits under Section 1(b)(2) of the Davis-Bacon Act (40 U.S.C. 276a) on behalf of laborers or mechanics are considered wages paid to such laborers or mechanics, subject to the provisions of Section IV, paragraph 3b, hereof. Also, for the purpose of this Section, regular contributions made or costs incurred for more than a weekly period (but not less often than quarterly) under plans, funds, or programs, which cover the particular weekly period, are deemed to be constructively made or incurred during such weekly period. Such laborers and mechanics shall be paid the appropriate wage rate and fringe benefits on the wage determination for the classification of work actually performed, without regard to skill, except as provided in paragraphs 4 and 5 of this Section IV.
- b. Laborers or mechanics performing work in more than one classification may be compensated at the rate specified for each classification for the time actually worked therein, provided, that the employer's payroll records accurately set forth the time spent in each classification in which work is performed.
- c. All rulings and interpretations of the Davis-Bacon Act and related acts contained in 29 CFR 1, 3, and 5 are herein incorporated by reference in this contract.

2. Classification:

- a. The SHA contracting officer shall require that any class of laborers or mechanics employed under the contract, which is not listed in the wage determination, shall be classified in conformance with the wage determination.
- b. The contracting officer shall approve an additional classification, wage rate and fringe benefits only when the following criteria have been met:
1. the work to be performed by the additional classification requested is not performed by a classification in the wage determination;
 2. the additional classification is utilized in the area by the construction industry;
 3. the proposed wage rate, including any bona fide fringe benefits, bears a reasonable relationship to the wage rates contained in the wage determination; and
 4. with respect to helpers, when such a classification prevails in the area in which the work is performed.
- c. If the contractor or subcontractors, as appropriate, the laborers and mechanics (if known) to be employed in the additional classification or their representatives, and the contracting officer agree on the classification and wage rate (including the amount designated for fringe benefits where appropriate), a report of the action taken shall be sent by the contracting officer to the DOL, Administrator of the Wage and Hour Division, Employment Standards Administration, Washington, D.C. 20210. The Wage and Hour Administrator, or an authorized representative, will approve, modify, or disapprove every additional classification action within 30 days of receipt and so advise the contracting officer or will notify the contracting officer within the 30-day period that additional time is necessary.
- d. In the event the contractor or subcontractors, as appropriate, the laborers or mechanics to be employed in the additional classification or their representatives, and the contracting officer do not agree on the proposed classification and wage rate (including the amount designated for fringe benefits, where appropriate), the contracting officer shall refer the questions, including the views of all interested parties and the recommendation of the contracting officer, to the Wage and Hour Administrator for determination. Said Administrator, or an authorized representative, will issue a determination within 30 days of receipt and so advise the contracting officer or will notify the contracting officer within the 30-day period that additional time is necessary.
- e. The wage rate (including fringe benefits where appropriate) determined pursuant to paragraph 2c or 2d of this Section IV shall be paid to all workers performing work in the additional classification from the first day on which work is performed in the classification.

3. Payment of Fringe Benefits:

- a. Whenever the minimum wage rate prescribed in the contract for a class of laborers or mechanics includes a fringe benefit which is not expressed as an hourly rate, the contractor or subcontractors, as appropriate, shall either pay the benefit as stated in the wage determination or shall pay another bona fide fringe benefit or an hourly case equivalent thereof.

- b. If the contractor or subcontractor, as appropriate, does not make payments to a trustee or other third person, he/she may consider as a part of the wages of any laborer or mechanic the amount of any costs reasonably anticipated in providing bona fide fringe benefits under a plan or program, provided, that the Secretary of Labor has found, upon the written request of the contractor, that the applicable standards of the Davis-Bacon Act have been met. The Secretary of Labor may require the contractor to set aside in a separate account assets for the meeting of obligations under the plan or program.
4. **Apprentices and Trainees (Programs of the U.S. DOL) and Helpers:**
- a. Apprentices:
1. Apprentices will be permitted to work at less than the predetermined rate for the work they performed when they are employed pursuant to and individually registered in a bona fide apprenticeship program registered with the DOL, Employment and Training Administration, Bureau of Apprenticeship and Training, or with a State apprenticeship agency recognized by the Bureau, or if a person is employed in his/her first 90 days of probationary employment as an apprentice in such an apprenticeship program, who is not individually registered in the program, but who has been certified by the Bureau of Apprenticeship and Training or a State apprenticeship agency (where appropriate) to be eligible for probationary employment as an apprentice.
 2. The allowable ratio of apprentices to journeyman-level employees on the job site in any craft classification shall not be greater than the ratio permitted to the contractor as to the entire work force under the registered program. Any employee listed on a payroll at an apprentice wage rate, who is not registered or otherwise employed as stated above, shall be paid not less than the applicable wage rate listed in the wage determination for the classification of work actually performed. In addition, any apprentice performing work on the job site in excess of the ratio permitted under the registered program shall be paid not less than the applicable wage rate on the wage determination for the work actually performed. Where a contractor or subcontractor is performing construction on a project in a locality other than that in which its program is registered, the ratios and wage rates (expressed in percentages of the journeyman-level hourly rate) specified in the contractor's or subcontractor's registered program shall be observed.
 3. Every apprentice must be paid at not less than the rate specified in the registered program for the apprentice's level of progress, expressed as a percentage of the journeyman-level hourly rate specified in the applicable wage determination. Apprentices shall be paid fringe benefits in accordance with the provisions of the apprenticeship program. If the apprenticeship program does not specify fringe benefits, apprentices must be paid the full amount of fringe benefits listed on the wage determination for the applicable classification. If the Administrator for the Wage and Hour Division determines that a different practice prevails for the applicable apprentice classification, fringes shall be paid in accordance with that determination.
 4. In the event the Bureau of Apprenticeship and Training, or a State apprenticeship agency recognized by the Bureau, withdraws approval of an apprenticeship program, the contractor or subcontractor will no longer be permitted to utilize apprentices at less than the applicable predetermined rate for the comparable work performed by regular employees until an acceptable program is approved.
- b. Trainees:
1. Except as provided in 29 CFR 5.16, trainees will not be permitted to work at less than the predetermined rate for the work performed unless they are employed pursuant to and individually registered in a program which has received prior approval, evidenced by formal certification by the DOL, Employment and Training Administration.
 2. The ratio of trainees to journeyman-level employees on the job site shall not be greater than permitted under the plan approved by the Employment and Training Administration. Any employee listed on the payroll at a trainee rate who is not registered and participating in a training plan approved by the Employment and Training Administration shall be paid not less than the applicable wage rate on the wage determination for the classification of work actually performed. In addition, any trainee performing work on the job site in excess of the ratio permitted under the registered program shall be paid not less than the applicable wage rate on the wage determination for the work actually performed.
 3. Every trainee must be paid at not less than the rate specified in the approved program for his/her level of progress, expressed as a percentage of the journeyman-level hourly rate specified in the applicable wage determination. Trainees shall be paid fringe benefits in accordance with the provisions of the trainee program. If the trainee program does not mention fringe benefits, trainees shall be paid the full amount of fringe benefits listed on the wage determination unless the Administrator of the Wage and Hour Division determines that there is an apprenticeship program associated with the corresponding journeyman-level wage rate on the wage determination which provides for less than full fringe benefits for apprentices, in which case such trainees shall receive the same fringe benefits as apprentices.
 4. In the event the Employment and Training Administration withdraws approval of a training program, the contractor or subcontractor will no longer be permitted to utilize trainees at less than the applicable predetermined rate for the work performed until an acceptable program is approved.
- c. Helpers:
- Helpers will be permitted to work on a project if the helper classification is specified and defined on the applicable wage determination or is approved pursuant to the conformance procedure set forth in Section IV.2. Any worker listed on a payroll at a helper wage rate, who is not a helper under an approved definition, shall be paid not less than the applicable wage rate on the wage determination for the classification of work actually performed.
5. **Apprentices and Trainees (Programs of the U.S. DOT):**
- Apprentices and trainees working under apprenticeship and skill training programs which have been certified by the Secretary of Transportation as promoting EEO in connection with Federal-aid highway construction programs are not subject to the requirements

of paragraph 4 of this Section IV. The straight time hourly wage rates for apprentices and trainees under such programs will be established by the particular programs. The ratio of apprentices and trainees to journeymen shall not be greater than permitted by the terms of the particular program.

6. **Withholding:**

The SHA shall upon its own action or upon written request of an authorized representative of the DOL withhold, or cause to be withheld, from the contractor or subcontractor under this contract or any other Federal contract with the same prime contractor, or any other Federally-assisted contract subject to Davis-Bacon prevailing wage requirements which is held by the same prime contractor, as much of the accrued payments or advances as may be considered necessary to pay laborers and mechanics, including apprentices, trainees, and helpers, employed by the contractor or any subcontractor the full amount of wages required by the contract. In the event of failure to pay any laborer or mechanic, including any apprentice, trainee, or helper, employed or working on the site of the work, all or part of the wages required by the contract, the SHA contracting officer may, after written notice to the contractor, take such action as may be necessary to cause the suspension of any further payment, advance, or guarantee of funds until such violations have ceased.

7. **Overtime Requirements:**

No contractor or subcontractor contracting for any part of the contract work which may require or involve the employment of laborers, mechanics, watchmen, or guards (including apprentices, trainees, and helpers described in paragraphs 4 and 5 above) shall require or permit any laborer, mechanic, watchman, or guard in any workweek in which he/she is employed on such work, to work in excess of 40 hours in such workweek unless such laborer, mechanic, watchman, or guard receives compensation at a rate not less than one-and-one-half times his/her basic rate of pay for all hours worked in excess of 40 hours in such workweek.

8. **Violation:**

Liability for Unpaid Wages; Liquidated Damages: In the event of any violation of the clause set forth in paragraph 7 above, the contractor and any subcontractor responsible thereof shall be liable to the affected employee for his/her unpaid wages. In addition, such contractor and subcontractor shall be liable to the United States (in the case of work done under contract for the District of Columbia or a territory, to such District or to such territory) for liquidated damages. Such liquidated damages shall be computed with respect to each individual laborer, mechanic, watchman, or guard employed in violation of the clause set forth in paragraph 7, in the sum of \$10 for each calendar day on which such employee was required or permitted to work in excess of the standard work week of 40 hours without payment of the overtime wages required by the clause set forth in paragraph 7.

9. **Withholding for Unpaid Wages and Liquidated Damages:**

The SHA shall upon its own action or upon written request of any authorized representative of the DOL withhold, or cause to be withheld, from any monies payable on account of work performed by the contractor or subcontractor under any such contract or any other Federal contract with the same prime contractor, or any other Federally-assisted contract subject to the Contract Work Hours and Safety Standards Act, which is held by the same prime contractor, such sums as may be determined to be necessary to satisfy any liabilities of such contractor or subcontractor for unpaid wages and liquidated damages as provided in the clause set forth in paragraph 8 above.

V. **STATEMENTS AND PAYROLLS**

(Applicable to all Federal-aid construction contracts exceeding \$2,000 and to all related subcontracts, except for projects located on roadways classified as local roads or rural collectors, which are exempt.)

1. **Compliance with Copeland Regulations (29 CFR 3):**

The contractor shall comply with the Copeland Regulations of the Secretary of Labor which are herein incorporated by reference.

2. **Payrolls and Payroll Records:**

- a. Payrolls and basic records relating thereto shall be maintained by the contractor and each subcontractor during the course of the work and preserved for a period of 3 years from the date of completion of the contract for all laborers, mechanics, apprentices, trainees, watchmen, helpers, and guards working at the site of the work.
- b. The payroll records shall contain the name, social security number, and address of each such employee; his or her correct classification; hourly rates of wages paid (including rates of contributions or costs anticipated for bona fide fringe benefits or cash equivalent thereof of the types described in Section 1(b)(2)(B) of the Davis Bacon Act); daily and weekly number of hours worked; deductions made; and actual wages paid. In addition, for Appalachian contracts, the payroll records shall contain a notation indicating whether the employee does, or does not, normally reside in the labor area as defined in Attachment A, paragraph 1. Whenever the Secretary of Labor, pursuant to Section IV, paragraph 3b, has found that the wages of any laborer or mechanic include the amount of any costs reasonably anticipated in providing benefits under a plan or program described in Section 1(b)(2)(B) of the Davis Bacon Act, the contractor and each subcontractor shall maintain records which show that the commitment to provide such benefits is enforceable, that the plan or program is financially responsible, that the plan or program has been communicated in writing to the laborers or mechanics affected, and show the cost anticipated or the actual cost incurred in providing benefits. Contractors or subcontractors employing apprentices or trainees under approved programs shall maintain written evidence of the registration of apprentices and trainees, and ratios and wage rates prescribed in the applicable programs.
- c. Each contractor and subcontractor shall furnish, each week in which any contract work is performed, to the SHA resident engineer a payroll of wages paid each of its employees (including apprentices, trainees, and helpers, described in Section IV, paragraphs 4 and 5, and watchmen and guards engaged on work during the preceding weekly payroll period). The payroll submitted shall set out accurately and completely all of the information required to be maintained under paragraph 2b of this Section V. This information may be submitted in any form desired. Optional Form WH-347 is available for this purpose and may be purchased from the Superintendent of Documents (Federal stock number 029-005-0014-1), U.S. Government Printing

Office, Washington, D.C. 20402. The prime contractor is responsible for the submission of copies of payrolls by all subcontractors.

- d. Each payroll submitted shall be accompanied by a "Statement of Compliance," signed by the contractor or subcontractor or his/her agent who pays or supervises the payment of the persons employed under the contract and shall certify the following:
 1. that the payroll for the payroll period contains the information required to be maintained under paragraph 2b of this Section V and that such information is correct and complete;
 2. that such laborer or mechanic (including each helper, apprentice, and trainee) employed on the contract during the payroll period has been paid the full weekly wages earned, without rebate, either directly or indirectly, and that no deductions have been made either directly or indirectly from the full wages earned, other than permissible deductions as set forth in the Regulations, 29 CFR 3;
 3. that each laborer or mechanic has been paid not less than the applicable wage rate and fringe benefits or cash equivalent for the classification of work performed, as specified in the applicable wage determination incorporated into the contract.
- e. The weekly submission of a properly executed certification set forth on the reverse side of Optional Form WH-347 shall satisfy the requirement for submission of the "Statement of Compliance" required by paragraph 2d of this Section V.
- f. The falsification of any of the above certifications may subject the contractor to civil or criminal prosecution under 18 U.S.C. 1001 and 31 U.S.C. 231.
- g. The contractor or subcontractor shall make the records required under paragraph 2b of this Section V available for inspection, copying, or transcription by authorized representatives of the SHA, the FHWA, or the DOL, and shall permit such representatives to interview employees during working hours on the job. If the contractor or subcontractor fails to submit the required records or to make them available, the SHA, the FHWA, the DOL, or all may, after written notice to the contractor, sponsor, applicant, or owner, take such actions as may be necessary to cause the suspension of any further payment, advance, or guarantee of funds. Furthermore, failure to submit the required records upon request or to make such records available may be grounds for debarment action pursuant to 29 CFR 5.12.

VI. RECORD OF MATERIALS, SUPPLIES, AND LABOR THIS SECTION DELETED JUNE 4, 2007.

VII. SUBLETTING OR ASSIGNING THE CONTRACT

1. The contractor shall perform with its own organization contract work amounting to not less than 30 percent (or a greater percentage if specified elsewhere in the contract) of the total original contract price, excluding any specialty items designated by the State. Specialty items may be performed by subcontract and the amount of any such specialty items performed may be deducted from the total original contract price before computing the amount of work required to be performed by the contractor's own organization (23 CFR 635).
 - a. "Its own organization" shall be construed to include only workers employed and paid directly by the prime contractor and equipment owned or rented by the prime contractor, with or without operators. Such term does not include employees or equipment of a subcontractor, assignee, or agent of the prime contractor.
 - b. "Specialty Items" shall be construed to be limited to work that requires highly specialized knowledge, abilities, or equipment not ordinarily available in the type of contracting organizations qualified and expected to bid on the contract as a whole and in general are to be limited to minor components of the overall contract.
2. The contract amount upon which the requirements set forth in paragraph 1 of Section VII is computed includes the cost of material and manufactured products which are to be purchased or produced by the contractor under the contract provisions.
3. The contractor shall furnish (a) a competent superintendent or supervisor who is employed by the firm, has full authority to direct performance of the work in accordance with the contract requirements, and is in charge of all construction operations (regardless of who performs the work) and (b) such other of its own organizational resources (supervision, management, and engineering services) as the SHA contracting officer determines is necessary to assure the performance of the contract.
4. No portion of the contract shall be sublet, assigned or otherwise disposed of except with the written consent of the SHA contracting officer, or authorized representative, and such consent when given shall not be construed to relieve the contractor of any responsibility for the fulfillment of the contract. Written consent will be given only after the SHA has assured that each subcontract is evidenced in writing and that it contains all pertinent provisions and requirements of the prime contract.

VIII. SAFETY: ACCIDENT PREVENTION

1. In the performance of this contract the contractor shall comply with all applicable Federal, State, and local laws governing safety, health, and sanitation (23 CFR 635). The contractor shall provide all safeguards, safety devices and protective equipment and take any other needed actions as it determines, or as the SHA contracting officer may determine, to be reasonably necessary to protect the life and health of employees on the job and the safety of the public and to protect property in connection with the performance of the work covered by the contract.
2. It is a condition of this contract, and shall be made a condition of each subcontract, which the contractor enters into pursuant to this contract, that the contractor and any subcontractor shall not permit any employee, in performance of the contract, to work in surroundings or under conditions which are unsanitary, hazardous or dangerous to his/her health or safety, as determined under construction safety and health standards (29 CFR 1926) promulgated by the Secretary of Labor, in accordance with Section 107 of the Contract Work Hours and Safety Standards Act (40 U.S.C. 333).
3. Pursuant to 29 CFR 1926.3, it is a condition of this contract that the Secretary of Labor or authorized representative thereof, shall have right of entry to any site of contract performance to inspect or investigate the matter of compliance with the construction safety

and health standards and to carry out the duties of the Secretary under Section 107 of the Contract Work Hours and Safety Standards Act (40 U.S.C. 333).

IX. FALSE STATEMENTS CONCERNING HIGHWAY PROJECTS

In order to assure high quality and durable construction in conformity with approved plans and specifications and a high degree of reliability on statements and representations made by engineers, contractors, suppliers, and workers on Federal-aid highway projects, it is essential that all persons concerned with the project perform their functions as carefully, thoroughly, and honestly as possible. Willful falsification, distortion, or misrepresentation with respect to any facts related to the project is a violation of Federal law. To prevent any misunderstanding regarding the seriousness of these and similar acts, the following notice shall be posted on each Federal-aid highway project (23 CFR 635) in one or more places where it is readily available to all persons concerned with the project:

NOTICE TO ALL PERSONNEL ENGAGED ON FEDERAL-AID HIGHWAY PROJECTS

18 U.S.C. 1020 reads as follows:

"Whoever, being an officer, agent, or employee of the United States, or of any State or Territory, or whoever, whether a person, association, firm, or corporation, knowingly makes any false statement, false representation, or false report as to the character, quality, quantity, or cost of the material used or to be used, or the quantity or quality of the work performed or to be performed, or the cost thereof in connection with the submission of plans, maps, specifications, contracts, or costs of construction on any highway or related project submitted for approval to the Secretary of Transportation; or

Whoever knowingly makes any false statement, false representation, false report or false claim with respect to the character, quality, quantity, or cost of any work performed or to be performed, or materials furnished or to be furnished, in connection with the construction of any highway or related project approved by the Secretary of Transportation; or

Whoever knowingly makes any false statement or false representation as to material fact in any statement, certificate, or report submitted pursuant to provisions of the Federal-aid Roads Act approved July 1, 1916, (39 Stat. 355), as amended and supplemented;

Shall be fined not more than \$10,000 or imprisoned not more than 5 years or both."

X. IMPLEMENTATION OF CLEAN AIR ACT AND FEDERAL WATER POLLUTION CONTROL ACT

(Applicable to all Federal-aid construction contracts and to all related subcontracts of \$100,000 or more.)

By submission of this bid or the execution of this contract, or subcontract, as appropriate, the bidder, Federal-aid construction contractor, or subcontractor, as appropriate, will be deemed to have stipulated as follows:

1. That any facility that is or will be utilized in the performance of this contract, unless such contract is exempt under the Clean Air Act, as amended (42 U.S.C. 1857 *et seq.*, as amended by Pub.L. 91-604), and under the Federal Water Pollution Control Act, as amended (33 U.S.C. 1251 *et seq.*, as amended by Pub.L. 92-500), Executive Order 11738, and regulations in implementation thereof (40 CFR 15) is not listed, on the date of contract award, on the U.S. Environmental Protection Agency (EPA) List of Violating Facilities pursuant to 40 CFR 15.20.
2. That the firm agrees to comply and remain in compliance with all the requirements of Section 114 of the Clean Air Act and Section 308 of the Federal Water Pollution Control Act and all regulations and guidelines listed thereunder.
3. That the firm shall promptly notify the SHA of the receipt of any communication from the Director, Office of Federal Activities, EPA, indicating that a facility that is or will be utilized for the contract is under consideration to be listed on the EPA List of Violating Facilities.
4. That the firm agrees to include or cause to be included the requirements of paragraph 1 through 4 of this Section X in every nonexempt subcontract, and further agrees to take such action as the government may direct as a means of enforcing such requirements.

XI. CERTIFICATION REGARDING DEBARMENT, SUSPENSION, INELIGIBILITY AND VOLUNTARY EXCLUSION

1. Instructions for Certification - Primary Covered Transactions:

(Applicable to all Federal-aid contracts - 49 CFR 29)

- a. By signing and submitting this proposal, the prospective primary participant is providing the certification set out below.
- b. The inability of a person to provide the certification set out below will not necessarily result in denial of participation in this covered transaction. The prospective participant shall submit an explanation of why it cannot provide the certification set out below. The certification or explanation will be considered in connection with the department or agency's determination whether to enter into this transaction. However, failure of the prospective primary participant to furnish a certification or an explanation shall disqualify such a person from participation in this transaction.
- c. The certification in this clause is a material representation of fact upon which reliance was placed when the department or agency determined to enter into this transaction. If it is later determined that the prospective primary participant knowingly rendered an erroneous certification, in addition to other remedies available to the Federal Government, the department or agency may terminate this transaction for cause of default.
- d. The prospective primary participant shall provide immediate written notice to the department or agency to whom this proposal is submitted if any time the prospective primary participant learns that its certification was erroneous when submitted or has become erroneous by reason of changed circumstances.
- e. The terms "covered transaction," "debarred," "suspended," "ineligible," "lower tier covered transaction," "participant," "person," "primary covered transaction," "principal," "proposal," and "voluntarily excluded," as used in this clause, have the meanings set out in the Definitions and Coverage sections of rules implementing Executive Order 12549. You may contact the department or agency to which this proposal is submitted for assistance in obtaining a copy of those regulations.

- f. The prospective primary participant agrees by submitting this proposal that, should the proposed covered transaction be entered into, it shall not knowingly enter into any lower tier covered transaction with a person who is debarred, suspended, declared ineligible, or voluntarily excluded from participation in this covered transaction, unless authorized by the department or agency entering into this transaction.
- g. The prospective primary participant further agrees by submitting this proposal that it will include the clause titled "Certification Regarding Debarment, Suspension, Ineligibility and Voluntary Exclusion-Lower Tier Covered Transaction," provided by the department or agency entering into this covered transaction, without modification, in all lower tier covered transactions and in all solicitations for lower tier covered transactions.
- h. A participant in a covered transaction may rely upon a certification of a prospective participant in a lower tier covered transaction that is not debarred, suspended, ineligible, or voluntarily excluded from the covered transaction, unless it knows that the certification is erroneous. A participant may decide the method and frequency by which it determines the eligibility of its principals. Each participant may, but is not required to, check the nonprocurement portion of the "Lists of Parties Excluded From Federal Procurement or Nonprocurement Programs" (Nonprocurement List) which is compiled by the General Services Administration.
- i. Nothing contained in the foregoing shall be construed to require establishment of a system of records in order to render in good faith the certification required by this clause. The knowledge and information of participant is not required to exceed that which is normally possessed by a prudent person in the ordinary course of business dealings.
- j. Except for transactions authorized under paragraph f of these instructions, if a participant in a covered transaction knowingly enters into a lower tier covered transaction with a person who is suspended, debarred, ineligible, or voluntarily excluded from participation in this transaction, in addition to other remedies available to the Federal Government, the department or agency may terminate this transaction for cause or default.

Certification Regarding Debarment, Suspension, Ineligibility and Voluntary Exclusion--Primary Covered Transactions

1. The prospective primary participant certifies to the best of its knowledge and belief, that it and its principals:
 - a. Are not presently debarred, suspended, proposed for debarment, declared ineligible, or voluntarily excluded from covered transactions by any Federal department or agency;
 - b. Have not within a 3-year period preceding this proposal been convicted of or had a civil judgement rendered against them for commission of fraud or a criminal offense in connection with obtaining, attempting to obtain, or performing a public (Federal, State or local) transaction or contract under a public transaction; violation of Federal or State antitrust statutes or commission of embezzlement, theft, forgery, bribery, falsification or destruction of records, making false statements, or receiving stolen property;
 - c. Are not presently indicted for or otherwise criminally or civilly charged by a governmental entity (Federal, State or local) with commission of any of the offenses enumerated in paragraph 1b of this certification; and
 - d. Have not within a 3-year period preceding this application/proposal had one or more public transactions (Federal, State or local) terminated for cause or default.
2. Where the prospective primary participant is unable to certify to any of the statements in this certification, such prospective participant shall attach an explanation to this proposal.

2. Instructions for Certification - Lower Tier Covered Transactions:

(Applicable to all subcontracts, purchase orders and other lower tier transactions of \$25,000 or more - 49 CFR 29)

- a. By signing and submitting this proposal, the prospective lower tier is providing the certification set out below.
- b. The certification in this clause is a material representation of fact upon which reliance was placed when this transaction was entered into. If it is later determined that the prospective lower tier participant knowingly rendered an erroneous certification, in addition to other remedies available to the Federal Government, the department, or agency with which this transaction originated may pursue available remedies, including suspension and/or debarment.
- c. The prospective lower tier participant shall provide immediate written notice to the person to which this proposal is submitted if at any time the prospective lower tier participant learns that its certification was erroneous by reason of changed circumstances.
- d. The terms "covered transaction," "debarred," "suspended," "ineligible," "primary covered transaction," "participant," "person," "principal," "proposal," and "voluntarily excluded," as used in this clause, have the meanings set out in the Definitions and Coverage sections of rules implementing Executive Order 12549. You may contact the person to which this proposal is submitted for assistance in obtaining a copy of those regulations.
- e. The prospective lower tier participant agrees by submitting this proposal that, should the proposed covered transaction be entered into, it shall not knowingly enter into any lower tier covered transaction with a person who is debarred, suspended, declared ineligible, or voluntarily excluded from participation in this covered transaction, unless authorized by the department or agency with which this transaction originated.
- f. The prospective lower tier participant further agrees by submitting this proposal that it will include this clause titled "Certification Regarding Debarment, Suspension, Ineligibility and Voluntary Exclusion-Lower Tier Covered Transaction," without modification, in all lower tier covered transactions and in all solicitations for lower tier covered transactions.

- g. A participant in a covered transaction may rely upon a certification of a prospective participant in a lower tier covered transaction that is not debarred, suspended, ineligible, or voluntarily excluded from the covered transaction, unless it knows that the certification is erroneous. A participant may decide the method and frequency by which it determines the eligibility of its principals. Each participant may, but is not required to, check the Nonprocurement List.
- h. Nothing contained in the foregoing shall be construed to require establishment of a system of records in order to render in good faith the certification required by this clause. The knowledge and information of participant is not required to exceed that which is normally possessed by a prudent person in the ordinary course of business dealings.
- i. Except for transactions authorized under paragraph e of these instructions, if a participant in a covered transaction knowingly enters into a lower tier covered transaction with a person who is suspended, debarred, ineligible, or voluntarily excluded from participation in this transaction, in addition to other remedies available to the Federal Government, the department or agency with which this transaction originated may pursue available remedies, including suspension and/or debarment.

* * * * *

Certification Regarding Debarment, Suspension, Ineligibility and Voluntary Exclusion--Lower Tier Covered Transactions:

- 1. The prospective lower tier participant certifies, by submission of this proposal, that neither it nor its principals is presently debarred, suspended, proposed for debarment, declared ineligible, or voluntarily excluded from participation in this transaction by any Federal department or agency.
- 2. Where the prospective lower tier participant is unable to certify to any of the statements in this certification, such prospective participant shall attach an explanation to this proposal.

* * * * *

XII. CERTIFICATION REGARDING USE OF CONTRACT FUNDS FOR LOBBYING

(Applicable to all Federal-aid construction contracts and to all related subcontracts which exceed \$100,000 - 49 CFR 20)

- 1. The prospective participant certifies, by signing and submitting this bid or proposal, to the best of his or her knowledge and belief, that:
 - a. No Federal appropriated funds have been paid or will be paid, by or on behalf of the undersigned, to any person for influencing or attempting to influence an officer or employee of any Federal agency, a Member of Congress, an officer or employee of Congress, or an employee of a Member of Congress in connection with the awarding of any Federal contract, the making of any Federal grant, the making of any Federal loan, the entering into of any cooperative agreement, and the extension, continuation, renewal, amendment, or modification of any Federal contract, grant, loan, or cooperative agreement.
 - b. If any funds other than Federal appropriated funds have been paid or will be paid to any person for influencing or attempting to influence an officer or employee of any Federal agency, a Member of Congress, an officer or employee of Congress, or an employee of a Member of Congress in connection with this Federal contract, grant, loan, or cooperative agreement, the undersigned shall complete and submit Standard Form-LLL, "Disclosure Form to Report Lobbying," in accordance with its instructions.
- 2. This certification is a material representation of fact upon which reliance was placed when this transaction was made or entered into. Submission of this certification is a prerequisite for making or entering into this transaction imposed by 31 U.S.C. 1352. Any person who fails to file the required certification shall be subject to a civil penalty of not less than \$10,000 and not more than \$100,000 for each such failure.
- 3. The prospective participant also agrees by submitting his or her bid or proposal that he or she shall require that the language of this certification be included in all lower tier subcontracts, which exceed \$100,000 and that all such recipients shall certify and disclose accordingly.

STANDARD SPECIAL PROVISION**GENERAL DECISION NC100127 09/30/2011 NC127**

Z-127

Date: September 30, 2011

General Decision Number: NC100127 09/30/2011 NC127

Superseded General Decision Numbers: NC20100010 and NC20100011

State: North Carolina

Construction Type: HIGHWAY

COUNTIES:

Anson
Cabarrus
Gaston
Mecklenburg
Union

HIGHWAY CONSTRUCTION PROJECTS (excluding tunnels, building structures in rest area projects, railroad construction, bascule, suspension and spandrel arch bridges designed for commercial navigation, bridges involving marine construction, and other major bridges).

Modification Number
0

Publication Date
09/30/2011

SUNC2011-071 09/16/2011

	Rates	Fringes
CARPENTER (Form Work Only)	14.70	
CEMENT MASON/CONCRETE FINISHER		
Anson, Cabarrus, and Gaston Counties	12.87	
Mecklenburg County	12.62	
Union County	12.75	
INSTALLER (Guardrail) (includes Guardrail/Post Driver Work)	11.16	
IRONWORKER (Reinforcing)	14.88	
LABORER		
Asphalt, Asphalt Distributor, Raker, and Spreader	11.78	
Common or General		
Anson and Cabarrus Counties	11.14	
Gaston County	10.63	
Mecklenburg County	11.55	
Union County	10.32	
Concrete Saw	14.26	
Landscape	10.35	
Luteman	12.88	
Mason Tender (Cement/Concrete)	11.25	
Pipelayer	12.93	
Traffic Control (Cone Setter)	12.53	
Traffic Control (Flagger)	9.99	

	Rates	Fringes
POWER EQUIPMENT OPERATORS		
Backhoe/Excavator/Trackhoe		
Anson, Cabarrus, and Gaston Counties	14.21	
Mecklenburg County	13.79	
Union County	14.53	
Broom/Sweeper	13.97	
Bulldozer		
Anson, Cabarrus, and Gaston Counties	15.46	
Mecklenburg County	15.90	
Union County	14.96	
Crane	19.11	
Curb Machine	14.43	
Distributor	14.99	
Drill	16.68	
Grader/Blade		
Anson, Cabarrus, Gaston, and Union Counties	17.99	
Mecklenburg County	18.65	
Loader		
Anson, Cabarrus, Gaston, and Union Counties	14.46	
Mecklenburg County	14.43	
Mechanic	17.13	
Milling Machine	15.80	
Oiler	14.36	
Paver	16.65	
Roller		
Anson, Cabarrus, Gaston, and Union Counties	13.22	
Mecklenburg County	13.29	
Scraper	15.85	
Screed	15.23	
Tractor	14.47	
TRUCK DRIVER		
4 Axle Truck	11.90	
Distributor	16.75	
Dump Truck		
Anson, Cabarrus, and Gaston Counties	13.46	
Mecklenburg County	13.79	
Union County	13.49	
Flatbed Truck	15.02	
Lowboy Truck		
Anson, Cabarrus, Gaston, and Mecklenburg Counties	15.26	
Union County	15.23	
Off the Road Truck	15.00	
Single Axle Truck	12.13	
Tack Truck	16.52	
Water Truck	13.16	

Welders – Receive rate prescribed for craft performing operation to which welding is incidental.

Unlisted classifications needed for work not included within the scope of the classifications listed may be added after award only as provided in the labor standards contract clauses (29 CFR 5.5(a)(1)(ii)).

In the listing above, the "SU" designation means that rates listed under that identifier do not reflect collectively bargained wage and fringe benefit rates. Other designations indicate unions whose rates have been determined to be prevailing.

WAGE DETERMINATION APPEALS PROCESS

1.) Has there been an initial decision in the matter? This can be:

- * an existing published wage determination
- * a survey underlying a wage determination
- * a Wage and Hour Division letter setting forth a position on a wage determination matter
- * a conformance (additional classification and rate) ruling

On survey related matters, initial contact, including requests for summaries of surveys, should be with the Wage and Hour Regional Office for the area in which the survey was conducted because those Regional Offices have responsibility for the Davis-Bacon survey program. If the response from this initial contact is not satisfactory, then the process described in 2.) and 3.) should be followed.

With regard to any other matter not yet ripe for the formal process described here, initial contact should be with the Branch of Construction Wage Determinations. Write to:

Branch of Construction Wage Determinations
Wage and Hour Division
U. S. Department of Labor
200 Constitution Avenue, N.W.
Washington, D.C. 20210

2.) If the answer to the question in 1.) is yes, then an interested party (those affected by the action) can request review and reconsideration from the Wage and Hour Administrator (See 29 CFR Part 1.8 and 29 CFR Part 7). Write to:

Wage and Hour Administrator
U.S. Department of Labor
200 Constitution Avenue, N.W.
Washington, D.C. 20210

The request should be accompanied by a full statement of the interested party's position and by any information (wage payment data, project description, area practice material, etc.) that the requestor considers relevant to the issue.

3.) If the decision of the Administrator is not favorable, an interested party may appeal directly to the Administrative Review Board (formerly the Wage Appeals Board). Write to:

Administrative Review Board
U.S. Department of Labor
200 Constitution Avenue, N.W.
Washington, D.C. 20210

4.) All decisions by the Administrative Review Board are final.

END OF GENERAL DECISION

***** STANDARD SPECIAL PROVISIONS *****

(3-17-10)

DIVISION ONE OF STANDARD SPECIFICATIONS

Division One of the 2012 NCDOT Standard Specifications for Roads and Structures (Standard Specifications) shall apply except as follows:

Definitions: Throughout Division One of the *Standard Specifications*, the term “Contractor” is replaced with “Design-Build Team”, the term “Bidder” is replaced with “Proposer,” the term “Bid” is replaced by “Price Proposal,” and the phrase “lowest Responsible Bidder” is replaced with “responsible Proposer with the lowest adjusted price.” The replacement of “Contractor” with “Design-Build Team” does not apply to Article 102-2. The replacement of the above terms also does not apply when the terms are part of a phrase (e.g. bid bond, prime contractor, total amount bid, etc.)

Deletions: Articles 102-4, 102-9(C)(2), 103-2(B), and 103-4(B) of the *Standard Specifications* are deleted from Design-Build Contracts.

Modifications: The remainder of this Standard Special Provision includes modifications to Division One of the *Standard Specifications*.

SECTION 101 DEFINITION OF TERMS

Page 1-3, Article 101-3, replace and add certain definitions as follows:

ADDITIONAL WORK

Additional work is that which results from a change or alteration to the contract and for which there are contract unit prices in the original contract or an executed supplemental agreement.

ADVERTISEMENT

The public advertisement inviting Statements of Qualifications for the design and construction of specific projects.

AWARD

The decision of the Department of Transportation to accept the proposal of the selected Design-Build Team for work which is subject to the furnishing of payment and performance bonds, and such other conditions as may be otherwise provided by law, the Request for Proposals, and the *Standard Specifications*.

CONTRACT

The executed agreement between the Department and the successful proposer, covering the performance of, and compensation for, the work. The term contract is all inclusive with reference to all written agreements affecting a contractual relationship and all documents referred to therein. The contract shall include, but not be limited to, the Request for Proposals, the Technical Proposal, the Price Proposal, the printed contract form and attachments, contract

bonds, plans and associated special provisions prepared by the Design-Build Team, standard specifications and supplemental specifications standard special provisions and project special provisions contained in the Request for Proposals or as developed by the Design-Build Team and accepted by the Department, and all executed supplemental agreements. The contract shall constitute one instrument.

DATE OF AVAILABILITY

That date set forth in the Request for Proposals, by which it is anticipated that the Contract will be executed and sufficient design efforts or work sites within the project limits will be available for the Design-Build Team to begin his controlling operations or design.

DESIGN-BUILD

A form of contracting in which the successful proposer undertakes responsibility for both the design and construction of a project.

DESIGN-BUILD TEAM

An individual, partnership, joint venture, corporation or other legal entity that furnishes the necessary design and construction services, whether by itself or through subcontracts.

DESIGN-BUILD PROPOSAL

A proposal to contract consisting of a separately sealed Technical Proposal and a separately sealed Price Proposal submitted in response to a Request for Proposals on a Design-Build project.

PLANS

The project plans, Standard Drawings, working drawings and supplemental drawings, or reproductions thereof, accepted by the Engineer, which show the location, character, dimensions and details of the work to be performed.

(A) Standard Drawings:

Drawings approved for repetitive use, showing details to be used where appropriate. All Standard Drawings approved by the Department plus subsequent revisions and additions. Standard Drawings are available for purchase from:

Randy A. Garris, PE
State Contract Officer
1591 Mail Service Center
Raleigh, NC 27699-1591

(B) Preliminary Plans:

Department-furnished drawings distributed in concert with a Request for Proposals, or as developed by the Design-Build Team.

(C) Project Plans:

Construction drawings prepared, sealed and completed by the Design-Build Team, or as provided by the Department, that contain specific details and dimensions peculiar to the work.

(D) Working Drawings and Supplemental Drawings:

Supplemental design sheets, shop drawings, or similar data which the Design-Build Team is required to submit to the Engineer.

(E) As-Constructed Drawings:

Final drawings prepared by the Design-Build Team, documenting the details and dimensions of the completed work.

PRICE PROPOSAL

The offer of a Proposer, submitted on the prescribed forms, to perform the work and furnish the labor and materials at the price quoted.

PROPOSAL (OR REQUEST FOR PROPOSALS)

The paper document provided by the Department that the proposer uses to develop his paper offer to perform the work at designated bid prices.

PROPOSER

An individual, partnership, firm, corporation, LLC, or joint venture formally submitting a Technical Proposal and Price Proposal in response to a Request for Proposals.

RIGHT OF WAY

The land area shown on the plans as right of way within which the project is to be constructed.

SCHEDULE OF VALUES

A schedule of work items necessary to complete work, along with the progress of each work item, primarily for the purpose of partial payments.

TABLE OF QUANTITIES

A listing of work items (corresponding to the items in the Transport pay item list) that contributes to a project completion. The table shall include estimated quantities for each work item.

TECHNICAL PROPOSAL

A submittal from a proposer, in accordance with requirements of the Request for Proposals, for the purpose of final selection. The Technical Proposal is defined to also include any supplemental information requested by the Department from a proposer prior to opening bids.

SECTION 102 PROPOSAL REQUIREMENTS AND CONDITIONS

Page 1-9, delete Article 102-1 and replace with the following:

102-1 INVITATION TO BID

After the advertisement has been made, an Invitation to Bid will be made available to known prequalified contractors and any other contracting firms, material suppliers and other interested parties who have requested they be placed on the Invitation to Bid mailing list, informing them that Statements of Qualifications and Proposals will be received for the construction of specific projects. Such invitation will indicate the contract identification number, length, locations and descriptions; a general summary of the scope of work to be performed; and information on how to receive a Request for Qualifications.

All projects will be advertised in daily newspapers throughout the state before the bid opening.

Page 1-12, delete Article 102-3 and replace with the following:

102-3 CONTENTS OF REQUEST FOR PROPOSALS

A Request for Proposals will be furnished by the Department to the selected proposers from among the respondents to the Request for Qualifications. Each Request for Proposals will be marked on the front cover by the Department with an identifier of the Proposer to whom it is being furnished. This Request for Proposals will state the location of the project and will show a schedule of contract items for which Technical and Price Proposals are invited. It will set forth the date and time Technical and Price Proposals are to be submitted and when the Price Proposals will be opened. The Request for Proposals will also include special provisions or requirements that vary from or are not contained in any preliminary design information or standard specifications.

The Request for Proposals will also include the printed contract forms and signature sheets for execution by both parties to the contract. In the event the Proposer is awarded the contract, execution of the Request for Proposals by the Proposer is considered the same as execution of the contract.

Standard specifications, sealed plans specifically identified as the Department's responsibility and other documents designated in the Request for Proposals shall be considered a part of the Request for Proposals whether or not they are attached thereto. All papers bound with the proposal are necessary parts thereof and shall not be detached, taken apart, or altered.

The names and identity of each prospective Proposer that receives a copy of the Request for Qualifications for the purposes of submitting a Statement of Qualifications shall be made public, except that a potential Proposer who obtains a Request for Qualifications may, at the time of ordering, request that his name remain confidential.

Up to three copies of the Request for Proposals will be furnished to each prospective Proposer. Additional copies may be purchased for the sum of \$25 each. The copy marked with the

Proposer's name and prequalification number shall be returned to the Department as the Proposer's Price Proposal.

Page 1-14, Article 102-7, 4th paragraph, delete the first two sentences and replace with the following:

The Proposer is cautioned that details shown in the subsurface investigation report are preliminary only. The subsurface investigation and subsurface report, if provided, is done so for information purposes only.

Pages 1-14, delete Article 102-8 and replace with the following:

102-8 PREPARATION AND SUBMISSION OF BIDS

All Price Proposals shall be prepared and submitted in accordance with the following requirements:

1. The Request for Proposals provided by the Department shall be used and shall not be taken apart or altered. The Price Proposal shall be submitted on the same form, which has been furnished to the Proposer by the Department as identified by the Proposer's name marked on the front cover by the Department.
2. All entries including signatures shall be written in ink.
3. The Proposer shall submit a lump sum or unit price for every item in the Price Proposal. The lump sum or unit prices bid for the various contract items shall be written in figures.
4. An amount bid shall be entered in the Request for Proposals for every item and the price shall be written in figures in the "Amount Bid" column in the Request for Proposals.
5. An amount bid shall be entered in the proposal for every item on which a unit price has been submitted. The amount bid for each item other than lump sum items shall be determined by multiplying each unit bid price by the quantity for that item and shall be written in figures in the Amount Bid column in the proposal.
6. The total amount bid shall be written in figures in the proper place in the Request for Proposals. The total amount bid shall be determined by adding the amounts bid for each lump sum item.
7. Changes in any entry shall be made by marking through the entry in ink and making the correct entry adjacent thereto in ink. A representative of the Proposer shall initial the change in ink.
8. The Price Proposal shall be properly executed. To constitute proper execution, the Price Proposal shall be executed in strict compliance with the following:
 - a. If a Price Proposal is by an individual, it shall show the name of the individual and shall be signed by the individual with the word "Individually" appearing under the signature. If the individual operates under a firm name, the bid shall be signed in the name of the individual doing business under the firm name.
 - b. If the Price Proposal is by a corporation, it shall be executed in the name of the corporation by the President, Vice President, or Assistant Vice President. It shall be

- attested by the Secretary or Assistant Secretary. The seal of the corporation shall be affixed. If the Price Proposal is executed on behalf of a corporation in any other manner than as above, a certified copy of the minutes of the Board of Directors of said corporation authorizing the manner and style of execution and the authority of the person executing shall be attached to the Price Proposal or shall be on file with the Department.
- c. If the Price Proposal is made by a partnership, it shall be executed in the name of the partnership by one of the general partners.
 - d. If the Price Proposal is made by a limited liability company, it shall be signed by the manager, member, or authorized agent and notarized.
 - e. If the Price Proposal is made by a joint venture, it shall be executed by each of the joint venturers in the appropriate manner set out above. In addition, the execution by the joint venturers shall appear below their names.
 - f. The Price Proposal execution shall be notarized by a notary public whose commission is in effect on the date of execution. Such notarization shall be applicable both to the Price Proposal and to the Non-Collusion Affidavit, Debarment Certification and Gift Ban Certification that is part of the signature sheets.
9. The Price Proposal shall not contain any unauthorized additions, deletions, or conditional bids.
 10. The Proposer shall not add any provision reserving the right to accept or reject an award or to enter into a contract pursuant to an award.
 11. The Price Proposal shall be accompanied by a bid bond on the form furnished by the Department or by a bid deposit. The bid bond shall be completely and properly executed in accordance with the requirements of Article 102-10 and as modified herein. The bid deposit shall be a certified check or cashier check in accordance with Article 102-10 and as modified herein.
 12. The Price Proposal shall be placed in a sealed envelope and shall have been delivered to and received by the Department prior to the time specified in the Request for Proposals.

Page 1-18, Article 102-10, 3rd paragraph, delete the fifth sentence and replace with the following:

The condition of the bid bond or bid deposit is: the Principal shall not withdraw its bid within 75 days after the submittal of the same, and if the Department shall award a contract to the Principal, the Principal shall within 14 calendar days after the notice of award is received by him, give payment and performance bonds with good and sufficient surety as required for the faithful performance of the contract and for the protection of all persons supplying labor and materials in the prosecution of the work.

Page 1-18, Article 102-10, delete the end of the Article beginning with, and inclusive of, the 6th paragraph

Pages 1-19, delete Article 102-12 and replace with the following:

102-12 WITHDRAWAL OR REVISION OF BIDS

A Design-Build Team will not be permitted to withdraw its Technical and Price Proposals after they have been submitted to the Department, unless allowed under Article 103-3 or unless otherwise approved by the State Highway Administrator.

Page 1-19, delete Article 102-13 and replace with the following:

102-13 RECEIPT AND OPENING OF BIDS

Price Proposals will be opened and read publicly on the date and time indicated in the Request for Proposals. The scores of the previously conducted evaluation of the Technical Proposals will also be read publicly in accordance with the procedures outlined in the Request for Proposals. Proposers, their authorized agents, and other interested parties are invited to be present.

Page 1-19, Article 102-14, Replace the 1st paragraph with the following:

102-14 REJECTION OF BIDS

Any Price Proposal submitted which fails to comply with any of the requirements of Articles 102-8, 102-9 or 102-10, or with the requirements of the project scope and specifications shall be considered irregular and may be rejected. A Price Proposal that does not contain costs for all proposal items shall be considered irregular and may be rejected.

**SECTION 103
AWARD AND EXECUTION OF CONTRACT**

Page 1-21, delete Article 103-1 and replace with the following:

103-1 CONSIDERATION OF PRICE PROPOSALS

After the Price Proposals are opened and read, they will be tabulated. The Price Proposal and score of the Technical Proposal will be made available in accordance with procedures outlined in the Request for Proposals. In the event of errors, omissions, or discrepancies in the bid prices, corrections to the Price Proposal will be made in accordance with the provisions of Article 103-2. Such corrected bid prices will be used to determine the lowest adjusted price.

After the reading of the Price Proposals and technical scores, the Department will calculate the lowest adjusted price as described in the Request for Proposals.

The right is reserved to reject any or all Price Proposals, to waive technicalities, to request the Proposer with the lowest adjusted price to submit an up-to-date financial and operating statement, to advertise for new proposals, or to proceed to do the work otherwise, if in the judgment of the Department, the best interests of the State will be promoted thereby.

Page 1-21, Subarticle 103-2(A), add items (6) and (7) as follows:

- (6) **Discrepancy in the “Total Amount Bid” and the addition of the “Amount Bid” for each line Item**

In the case of the Total Amount Bid does not equal the summation of each Amount Bid for the line items, the summation of each Amount Bid for the line items shall be deemed to be the correct Total Amount Bid for the entire project.

- (7) **Omitted Total Amount Bid –Amount Bid Completed**

If the Total Amount Bid is not completed and the Amount Bid for all line items is completed the Total Amount Bid shall be the summation of the Amount Bid for all line items.

Page 1-24, Subarticle 103-4(A), first paragraph, replace the 4th and 5th sentences with the following:

Where award is to be made, the notice of award will be issued within 75 days after the submittal of Price Proposals, except with the consent of the responsible Proposer with the lowest adjusted price the decision to award the contract to such bidder may be delayed for as long a time as may be agreed upon by the Department and such Proposer. In the absence of such agreement, the Proposer may withdraw his Price Proposal at the expiration of the 75 days without penalty if no notice of award has been issued.

Page 1-25, Article 103-6, delete the 1st and 2nd paragraphs and replace with the following:

Checks that have been furnished as a bid deposit will be retained until after the contract bonds have been furnished by the successful proposer, at which time the checks that were furnished as a bid deposit will be returned.

SECTION 104 SCOPE OF WORK

Page 1-26, delete Article 104-1 and replace with the following:**104-1 INTENT OF CONTRACT**

The intent of the contract is to prescribe the work or improvements that the Design-Build Team undertakes to perform, in full compliance with the contract documents. In case the method of construction or character of any part of the work is not covered by the contract, this section shall apply. The Design-Build Team shall perform all work in accordance with the contract or as may be modified by written orders, and shall do such special, additional, extra, and incidental work as may be considered necessary to complete the work to the full intent of the contract. Unless otherwise provided elsewhere in the contract, the Design-Build Team shall furnish all implements, machinery, equipment, tools, materials, supplies, transportation, and labor necessary for the design, prosecution and completion of the work.

Page 1-26, Article 104-3, replace “plans or details of construction” with “contract” in all instances within this Article.

Page 1-35, Article 104-10, replace the first paragraph with the following:

104-10 MAINTENANCE OF THE PROJECT

The Design-Build Team shall maintain the project from the date of beginning construction on the project until the project is finally accepted. For sections of facilities impacted by utility construction / relocation performed by the Design-Build Team prior to beginning construction on the roadway project, maintenance of the impacted sections of facilities shall be performed by the Design-Build Team beginning concurrently with the impact. All existing and constructed guardrail / guiderail within the project limits shall be included in this maintenance. This maintenance shall be continuous and effective and shall be prosecuted with adequate equipment and forces to the end that all work covered by the contract is kept in satisfactory and acceptable conditions at all times. The Design-Build Team shall perform weekly inspections of guardrail and guiderail and shall report damages to the Engineer on the same day of the weekly inspection. Where damaged guardrail or guiderail is repaired or replaced as a result of maintaining the project in accordance with this Article, such repair or replacement shall be performed within 7 consecutive calendar days of such inspection report.

Page 1-35, Article 104-10, add the following after the last paragraph:

The Design-Build Team will not be compensated for performance of weekly inspections and damage reports for the guardrail / guiderail. Other maintenance activities for existing guardrail / guiderail will be handled in accordance with Articles 104-7 and 104-8.

**SECTION 105
CONTROL OF WORK**

Pages 1-40, delete Article 105-2 and replace with the following:

105-2 PLANS AND WORKING DRAWINGS

All plans shall be supplemented by such approved working drawings as are necessary to adequately control the work. Working drawings furnished by the Design-Build Team and approved by the Engineer shall consist of such detailed drawings as may be required to adequately control the work. They may include stress sheets, shop drawings, erection drawings, falsework drawings, cofferdam drawings, bending diagrams for reinforcing steel, catalog cuts, or any other supplementary drawings or similar data required of the Design-Build Team. When working drawings are approved by the Engineer, such approval shall not operate to relieve the Design-Build Team of any of his responsibility under the contract for the successful completion of the work.

Changes on shop drawings after approval and/or distribution shall be subject to the approval of the Engineer and he shall be furnished a record of such changes.

Page 1-41, Article 105-3, add the following after the 3rd paragraph:

The Design-Build Team shall bear all the costs of providing the burden of proof that the nonconforming work is reasonable and adequately addresses the design purpose. The Design-

Build Team shall bear all risk for continuing with nonconforming work in question until it is accepted.

The Engineer may impose conditions for acceptance of the nonconforming work. The Design-Build Team shall bear all costs for fulfilling the conditions.

The decisions whether the product satisfies the design purpose, whether the nonconforming work is reasonably acceptable and the conditions for acceptance are at the sole discretion of the Engineer.

Pages 1-41, delete Article 105-4 and replace with the following:

105-4 COORDINATION OF PLANS, SPECIFICATIONS, SUPPLEMENTAL SPECIFICATIONS, AND SPECIAL PROVISIONS

The Request for Proposals, all construction Plans, the Standard Specifications, Supplemental Specifications and Special Provisions and all supplementary documents are essential parts of the contract and a requirement occurring in one is as binding as though occurring in all. They are complementary and describe and provide the complete contract.

In case of discrepancy or conflict, the order in which they govern shall be as follows:

- (A) Request for Proposals, in which Project Special Provisions govern Standard Special Provisions
- (B) Technical Proposal from the Design-Build Team
- (C) Accepted Plans and Details from the Design-Build Team, or sealed plans provided by the Department, as applicable
- (D) Standard Drawings
- (E) Standard Specifications

Where dimensions on the plans are given or can be computed from other given dimensions they shall govern over scaled dimensions.

The Design-Build Team shall take no advantage of any error or omission in the plans, estimated quantities, or specifications. In the event the Design-Build Team discovers an error or omission, he shall immediately notify the Engineer.

Page 1-44, delete Article 105-9 and replace with the following:

105-9 CONSTRUCTION STAKES, LINES, AND GRADES

The Design-Build Team shall be responsible for all surveying, construction staking and layout required in the performance of the work. He will be responsible for the accuracy of lines, slopes, grades and other engineering work which he provides under this contract.

**SECTION 106
CONTROL OF MATERIAL**

Page 1-49, Article 106-2, add the following after the second paragraph:

Prior to beginning construction, the Design-Build Team shall provide a Table of Quantities as described in Article 101-3 of these specifications.

The Table of Quantities Work Items shall correspond to Pay Items as defined in the Standard Specifications. These Work Items have associated Materials and Conversion Factors. For non-standard Work Items, a Generic Work Item with the correct Unit of Measure and in an appropriate category will be used. For example, “GENERIC TRAFFIC CONTROL ITEM – EA” or “GENERIC RETAINING WALL ITEM – LF”. For these Generic Work Items, Materials must be defined and appropriate conversion factors submitted.

An initial Table of Quantities shall be submitted no later than 30 calendar days after the date of award. The Table of Quantities shall be updated and resubmitted within 14 days of when a set of Plans is sealed as Release for Construction (RFC) Plans, and whenever there are substantial changes to the Quantities on previously incorporated RFC Plans.

Page 1-51, Article 106-6, add the following after the last paragraph:

For items normally pretested by the Department, the Design-Build Team shall provide a minimum of 30 days notice prior to the beginning of production of the items for this project along with final approved shop drawings.

SECTION 107 LEGAL RELATIONS AND RESPONSIBILITY TO PUBLIC

Page 1-61, delete Article 107-18 and replace with the following:

107-18 FURNISHING RIGHT OF WAY

The responsibility for coordinating the securing of all necessary rights of way is as outlined in the Request for Proposals.

SECTION 108 PROSECUTION AND PROGRESS

Page 1-64. Article 108-2, replace the 2nd paragraph with the following:

The Design-Build Team shall submit a Progress Schedule for review within thirty (30) calendar days of receiving Notice of Award. The Department will review the Progress Schedule within twenty-one (21) calendar days of receipt. The Design-Build Team shall make any necessary corrections and adjustments to the Progress Schedule as necessitated by the Department’s review within seven (7) calendar days. The Department will review the revised Progress Schedule within seven (7) calendar days of receipt.

Page 1-64, Subarticle 108-2(A)(1), add the following:

- (k) Utility relocation and construction

Page 1-65, Subarticle 108-2(A)(2), add the following:

- (h) Critical design submittal dates
- (i) Critical permitting dates

- (j) Completion of right of way acquisition
- (k) Completion of utility relocation and construction

Page 1-65, Article 108-2, add the following:

- (D)** The Design-Build Team shall provide a written narrative each month detailing the work and percentage of work completed, anticipated sequence of upcoming work (2 month forecast), controlling operation(s), intermediate completion dates, and milestones. If any milestones are exceeded or will not be achieved, the Design-Build Team shall provide in the written narrative details of the delay; controlling operation affected, impacts to other operations, revisions to future intermediate completion dates and milestones, and remedial action necessary to get the project back to the original completion date.

Page 1-65, delete Article 108-3 and replace with the following:

108-3 PRECONSTRUCTION AND PRE-DESIGN CONFERENCES

The selected Design-Build Team shall meet with the Engineer for a pre-design conference concerning the design phase of the work. This conference shall be held prior to the commencement of work, as it is determined according to Article 108-1, and will be scheduled by the Engineer. At the predesign conference, the Design-Build Team shall furnish authorized signature forms and a list of any proposed subcontractors associated with the design of the project.

A preconstruction conference shall be held at least 10 working days before construction activity begins. This second conference, concerning the construction phase, shall also be scheduled by the Engineer. The Design-Build Team shall give the Engineer a minimum of 45 days notice before he plans to begin construction activities. This will allow the Engineer time for any environmental agency representatives involved in the permitting process, as well as any other pertinent entities, to be scheduled to attend the preconstruction conference. If the Design-Build Team is responsible for utilities in accordance with Article 105-8 and the Request for Proposals, he shall be responsible for coordinating with the Engineer in scheduling their attendance and for notifying them. The Design-Build Team shall also be responsible for coordinating with the Engineer in scheduling the attendance of subcontractors and others deemed appropriate, and for notifying them.

At the preconstruction conference, a list of any proposed subcontractors and major material suppliers associated with the construction of the project will be submitted.

If the contract has a DBE requirement, the Design-Build Team shall submit copies of completed and signed DBE subcontracts, purchase orders, or invoices to the Department.

The Design-Build Team shall submit a traffic control plan in accordance with Article 1101-5 and the Request for Proposals. The Design-Build Team shall designate an employee who is competent and experienced in traffic control to implement and monitor the traffic control plan. The qualifications of the designated employee must be satisfactory to the Engineer.

The Design-Build Team shall submit a safety plan and designate an employee as Safety Supervisor.

Both plans shall be submitted at the preconstruction conference and must be satisfactory to the Engineer. Should the design plan include activities that would place personnel on the work site, traffic control and safety plans for those activities shall be submitted at the predesign conference.

During the preconstruction conference, the Engineer will designate a Department employee or employees who will be responsible to see that the traffic control plans and any alterations thereto are implemented and monitored to the end that traffic is carried through the work in an effective manner. If approved by the Engineer, the Design-Build Team may designate one employee to be responsible for both the traffic control and safety plans. The Design-Build Team shall not designate its superintendent as the responsible person for either the traffic control plan or the safety plan, unless approved by the Engineer.

If the project requires that Design-Build Team or State personnel work from falsework, within shoring, or in any other hazardous area the Design-Build Team shall submit, as part of the Design-Build Team's safety plan, specific measures it will use to ensure worker safety.

The Design-Build Team shall also submit a program for erosion control and pollution prevention on all projects involving clearing and grubbing, earthwork, structural work, or other construction, when such work is likely to create erosion or pollution problems.

If the Design-Build Team fails to provide the required submissions, the Engineer may order the preconstruction conference suspended until such time as they are furnished. Work shall not begin until the preconstruction conference has been concluded and the safety plan has been approved, unless authorized by the Engineer. The Design-Build Team shall not be entitled to additional compensation or an extension of contract time resulting from any delays due to such a suspension.

The Design-Build Team shall designate a qualified employee as Quality Control Manager. The Quality Control Manager shall be responsible for implementing and monitoring the quality control requirements of the project.

Page 1-65, Article 108-4, add the following sentence to the end of this article:

The Design-Build Team shall record the proceedings of these conferences and distribute the final minutes of the conferences to all attendees.

Page 1-66, Article 108-6, replace “40%” with “30%” in the 1st paragraph.

Page 1-66, Article 108-6, replace “35%” with “25%” in the 2nd paragraph.

Pages 1-68, delete Article 108-8 and replace with the following:

108-8 FAILURE TO MAINTAIN SATISFACTORY PROGRESS

The Engineer will check the Design-Build Team's progress at the time each partial pay request is received. The Design-Build Team's progress may be considered as unsatisfactory if, according to the Progress schedule, the projected finish date for all work exceeds the scheduled finish date by more than 10%.

When the Design-Build Team's progress is found to be unsatisfactory as described above, the Engineer may make written demand of the Design-Build Team to state in writing the reason for the unsatisfactory progress and produce such supporting data as the Engineer may require or the

Design-Build Team may desire to submit. The Engineer will consider the justifications submitted by the Design-Build Team and extensions of the completion date that have or may be allowed in accordance with Article 108-10(B) and as modified herein.

When the Design-Build Team cannot satisfactorily justify the unsatisfactory progress the Engineer may invoke one or more of the following sanctions:

1. Withhold anticipated liquidated damages from amounts currently due or which become due.
2. Remove the Design-Build Team and individual managing firms of the Design-Build Team and/or prequalified design firms from the Department's Prequalified Bidders List.

When any of the above sanctions have been invoked, they shall remain in effect until rescinded by the Engineer.

Page 1-71, Article 108-10(B), add the following as the first paragraph:

Only delays to activities which affect the completion date or intermediate contract date will be considered for an extension of contract time. No extensions will be granted until a delay occurs which impacts the project's critical path and extends the work beyond the contract completion date or intermediate completion date. Any extension to the completion date or intermediate contract date will be based on the number of calendar days the completion date or intermediate completion date is impacted as determined by the Engineer's analysis.

Pages 1-71, delete Subarticle 108-10(B)(1) in its entirety.

Page 1-75, Article 108-13, delete bullet (E)(2) in its entirety.

SECTION 109 MEASUREMENT AND PAYMENT

Page 1-76, Article 109-2, delete the last sentence of the 1st paragraph and replace with the following:

Payment to the Design-Build Team will be made only for the work completed, certified and accepted in accordance with the terms of the contract.

Pages 1-81, delete Article 109-4(A) and replace with the following:

109-4 PARTIAL PAYMENTS

(A) General:

Partial payments will be based upon progress estimates prepared by the Engineer at least once each month on the date established by the Engineer. Partial payments may be made twice each month if in the judgment of the Engineer the amount of work performed is sufficient to warrant such payment. No partial payment will be made when the total value of work performed since the last partial payment amounts to less than \$10,000.00.

Partial payments will be approximate only and will be subject to correction in the final estimate and payment.

When the contract includes one lump sum price for the entire work required by the contract, partial payments for the lump sum design-build price shall be based on a certified Schedule of Values submitted by the successful Design-Build Team and approved by the Engineer. The certification shall indicate the Design-Build Team has reviewed the information submitted and the information accurately represents the work performed for which payment is requested. The certified Schedule of Values shall be submitted no later than 30 calendar days after the date of award. Each item on the certified Schedule of Values shall be assigned a cost and quantity and shall be identified as an activity on the progress schedule. A revised certified Schedule of Values shall be submitted with each update of the Progress schedule as described in Article 108-2, and as modified herein, or when requested by the Engineer. A certified copy of the Table of Quantities shall also be submitted with each payment request. The certification of the Table of Quantities shall indicate the Design-Build Team has reviewed the information submitted and the information accurately represents the materials for the work performed for which payment is requested.

When the contract includes lump sum items for portions of the work required by the contract, and the applicable section of the Specifications or Request for Proposals specify the means by which the total amount bid be included in the partial pay estimates, the Engineer will determine amounts due on the partial pay estimate in accordance with the applicable portion of the Specifications or Request for Proposals.

The Engineer will withhold an amount sufficient to cover anticipated liquidated damages as determined by the Engineer.

Page 1-82, Subarticle 109-5(D), delete the 4th and 5th paragraphs and replace with the following:

Partial payments will not be made on seed or any living or perishable plant materials.

Partial payment requests shall not be submitted by the Design-Build Team until those items requested have corresponding signed and sealed RFC plans accepted by the Department.

Pages 1-84, Article 109-10, add the following as bullets (E) and (F) under the 1st paragraph.

- (E) As-constructed plans or other submittals as required by the Contract.
- (F) Documents or guarantees to support any warranty provided by the Design Build Team.

ITEMIZED PROPOSAL FOR CONTRACT No. C 202831

July 28, 2011 1:48 pm

Page 1 of 1

County: Mecklenburg

Line #	Item Number #	Sec #	Description	Quantity	Unit Cost	Amount
ROADWAY ITEMS						
0001	0000900000-N	SP	GENERIC MISCELLANEOUS ITEM DESIGN AND CONSTRUCTION	Lump Sum	L.S.	

1348/Jul28/Q1.0/D 900000 /E1

Total Amount Of Bid For Entire Project: _____

FUEL USAGE FACTOR CHART AND ESTIMATE OF QUANTITIES

Description of Work	Units	Fuel Usage Factor Diesel #2	Estimate of Quantities
Unclassified Excavation	Gal / CY	0.29	_____ CY
Borrow Excavation	Gal / CY	0.29	_____ CY
Class IV Subgrade Stabilization Aggregate Base Course Aggregate for Cement Treated Base Course Portland Cement for Cement Treated Base Course	Gal / Ton	0.55	_____ Tons
Asphalt Concrete Base Course Asphalt Concrete Intermediate Course Asphalt Concrete Surface Course Open-Graded Asphalt Friction Course Sand Asphalt Surface Course, Type F-1	Gal / Ton	2.90	_____ Tons
Portland Cement Concrete Pavement Concrete Shoulders Adjacent to Pavement	Gal / CY	0.98	_____ CY
Structural Concrete (Cast-in-Place Only)	Gal / CY	0.98	_____ CY

The above quantities represent a reasonable estimate of the total quantities anticipated, for each item, as pertaining to fuel price adjustments, and is representative of the design proposed in the Technical Proposal submitted under separate cover.

Or

The Design-Build Team elects not to pursue reimbursement for Fuel Price Adjustments on this project.

The information submitted on this sheet is claimed as a “Trade Secret” in accordance with the requirements of G.S. 66-152(3) until such time as the Price Proposal is opened.

Signature, Title

Dated

Print Name, Title

(Submit a copy of this sheet in a separate sealed package with the outer wrapping clearly marked “Fuel Price Adjustment” and deliver with the Technical and Cost Proposal.)

LISTING OF DBE SUBCONTRACTORS					Sheet _____ of _____
Firm Name and Address	Item No.	Item Description	* Agreed upon Unit Price	** Dollar Volume of Item	
Name Address					
Name Address					
Name Address					
Name Address					
Name Address					
Name Address					
Name Address					

This form must be completed in order for the Bid to be considered responsive and be publicly read. Bidders with no DBE participation must so indicate this on the form by entering the word or number *zero*.

LISTING OF DBE SUBCONTRACTORS					Sheet _____ of _____
Firm Name and Address	Item No.	Item Description	* Agreed upon Unit Price	** Dollar Volume of Item	
Name Address					
Name Address					
Name Address					
Name Address					
Name Address					
Name Address					
Name Address					

This form must be completed in order for the Bid to be considered responsive and be publicly read. Bidders with no DBE participation must so indicate this on the form by entering the word or number *zero*.

LISTING OF DBE SUBCONTRACTORS					Sheet _____ of _____
Firm Name and Address	Item No.	Item Description	* Agreed upon Unit Price	** Dollar Volume of Item	
Name Address					
Name Address					
Name Address					
Name Address					
Name Address					
Name Address					
Name Address					

This form must be completed in order for the Bid to be considered responsive and be publicly read. Bidders with no DBE participation must so indicate this on the form by entering the word or number *zero*.

LISTING OF DBE SUBCONTRACTORS				
			Sheet _____ of _____	
Firm Name and Address	Item No.	Item Description	* Agreed upon Unit Price	** Dollar Volume of Item
Name Address				
Name Address				
Name Address				
Name Address				

COST OF CONSTRUCTION WORK ONLY \$ _____

*The Dollar Volume shown in this column shall be the Actual Price Agreed Upon by the Prime Contractor and the DBE subcontractor, and these prices will be used to determine the percentage of the DBE participation in the contract.

** Dollar Volume of DBE Subcontractor \$ _____

Percentage of Total Construction Cost _____ %

(Including Right of Way Acquisition Services)

** - Must have entry even if figure to be entered is zero.

** - *If firm is a Material Supplier Only, show Dollar Volume as 60% of Agreed Upon Amount from Letter of Intent.
If firm is a Manufacturer, show Dollar Volume as 100% of Agreed Upon Amount from Letter of Intent.*

**This form must be completed in order for the Bid to be considered responsive and be publicly read.
Bidders with no DBE participation must so indicate this on the form by entering the word or number zero.**

**EXECUTION OF BID
NON-COLLUSION AFFIDAVIT, DEBARMENT CERTIFICATION AND GIFT BAN CERTIFICATION**

CORPORATION

The person executing the bid, on behalf of the Bidder, being duly sworn, solemnly swears (or affirms) that neither he, nor any official, agent or employee of the bidder has entered into any agreement, participated in any collusion, or otherwise taken any action which is in restraint of free competitive bidding in connection with any bid or contract, that the bidder has not been convicted of violating *N.C.G.S. § 133-24* within the last three years, and that the Bidder intends to do the work with its own bonafide employees or subcontractors and is not bidding for the benefit of another contractor.

In addition, execution of this bid in the proper manner also constitutes the Bidder's certification of status under penalty of perjury under the laws of the United States in accordance with the Debarment Certification attached, provided that the Debarment Certification also includes any required statements concerning exceptions that are applicable.

N.C.G.S. § 133-32 and Executive Order 24 prohibit the offer to, or acceptance by, any State Employee of any gift from anyone with a contract with the State, or from any person seeking to do business with the State. By execution of any response in this procurement, you attest, for your entire organization and its employees or agents, that you are not aware that any such gift has been offered, accepted, or promised by any employees of your organization.

SIGNATURE OF CONTRACTOR

Full name of Corporation

Address as prequalified

Attest _____
Secretary/Assistant Secretary
Select appropriate title

By _____
President/Vice President/Assistant Vice President
Select appropriate title

Print or type Signer's name

Print or type Signer's name

CORPORATE SEAL

AFFIDAVIT MUST BE NOTARIZED

Subscribed and sworn to before me this the _____ day of _____, 20_____

Signature of Notary Public
Of _____ County
State of _____
My Commission Expires _____

NOTARY SEAL

**EXECUTION OF BID
NON-COLLUSION AFFIDAVIT, DEBARMENT CERTIFICATION AND GIFT BAN CERTIFICATION**

PARTNERSHIP

The person executing the bid, on behalf of the Bidder, being duly sworn, solemnly swears (or affirms) that neither he, nor any official, agent or employee of the bidder has entered into any agreement, participated in any collusion, or otherwise taken any action which is in restraint of free competitive bidding in connection with any bid or contract, that the bidder has not been convicted of violating *N.C.G.S. § 133-24* within the last three years, and that the Bidder intends to do the work with its own bonafide employees or subcontractors and is not bidding for the benefit of another contractor.

In addition, execution of this bid in the proper manner also constitutes the Bidder's certification of status under penalty of perjury under the laws of the United States in accordance with the Debarment Certification attached, provided that the Debarment Certification also includes any required statements concerning exceptions that are applicable.

N.C.G.S. § 133-32 and Executive Order 24 prohibit the offer to, or acceptance by, any State Employee of any gift from anyone with a contract with the State, or from any person seeking to do business with the State. By execution of any response in this procurement, you attest, for your entire organization and its employees or agents, that you are not aware that any such gift has been offered, accepted, or promised by any employees of your organization.

SIGNATURE OF CONTRACTOR

Full Name of Partnership

Address as Prequalified

By

Signature of Witness

Signature of Partner

Print or type Signer's name

Print or type Signer's name

AFFIDAVIT MUST BE NOTARIZED

Subscribed and sworn to before me this the
day of _____ 20____.

Signature of Notary Public

of _____ County

State of _____

My Commission Expires: _____

NOTARY SEAL

**EXECUTION OF BID
NON-COLLUSION AFFIDAVIT, DEBARMENT CERTIFICATION AND GIFT BAN CERTIFICATION**

LIMITED LIABILITY COMPANY

The person executing the bid, on behalf of the Bidder, being duly sworn, solemnly swears (or affirms) that neither he, nor any official, agent or employee of the bidder has entered into any agreement, participated in any collusion, or otherwise taken any action which is in restraint of free competitive bidding in connection with any bid or contract, that the bidder has not been convicted of violating *N.C.G.S. § 133-24* within the last three years, and that the Bidder intends to do the work with its own bonafide employees or subcontractors and is not bidding for the benefit of another contractor.

In addition, execution of this bid in the proper manner also constitutes the Bidder's certification of status under penalty of perjury under the laws of the United States in accordance with the Debarment Certification attached, provided that the Debarment Certification also includes any required statements concerning exceptions that are applicable.

N.C.G.S. § 133-32 and Executive Order 24 prohibit the offer to, or acceptance by, any State Employee of any gift from anyone with a contract with the State, or from any person seeking to do business with the State. By execution of any response in this procurement, you attest, for your entire organization and its employees or agents, that you are not aware that any such gift has been offered, accepted, or promised by any employees of your organization.

SIGNATURE OF CONTRACTOR

_____ Full Name of Firm

_____ Address as Prequalified

Signature of Member/Manager/Authorized Agent

_____ Individually

_____ Print or type Signer's Name

AFFIDAVIT MUST BE NOTARIZED

Subscribed and sworn to before me this the
____ day of _____ 20__.

NOTARY SEAL

Signature of Notary Public
of _____ County
State of _____
My Commission Expires: _____

EXECUTION OF BID
NON-COLLUSION AFFIDAVIT, DEBARMENT CERTIFICATION AND GIFT BAN CERTIFICATION
JOINT VENTURE (2) or (3)

The person executing the bid, on behalf of the Bidder, being duly sworn, solemnly swears (or affirms) that neither he, nor any official, agent or employee of the bidder has entered into any agreement, participated in any collusion, or otherwise taken any action which is in restraint of free competitive bidding in connection with any bid or contract, that the bidder has not been convicted of violating N.C.G.S. § 133-24 within the last three years, and that the Bidder intends to do the work with its own bonafide employees or subcontractors and is not bidding for the benefit of another contractor.

In addition, execution of this bid in the proper manner also constitutes the Bidder's certification of status under penalty of perjury under the laws of the United States in accordance with the Debarment Certification attached, provided that the Debarment Certification also includes any required statements concerning exceptions that are applicable.

N.C.G.S. § 133-32 and Executive Order 24 prohibit the offer to, or acceptance by, any State Employee of any gift from anyone with a contract with the State, or from any person seeking to do business with the State. By execution of any response in this procurement, you attest, for your entire organization and its employees or agents, that you are not aware that any such gift has been offered, accepted, or promised by any employees of your organization.

SIGNATURE OF CONTRACTORS

Instructions: 2 Joint Venturers Fill in lines (1), (2) and (3) and execute. 3 Joint Venturers Fill in lines (1), (2), (3) and (4) and execute. On Line (1), fill in the name of the Joint Venture Company. On Line (2), fill in the name of one of the joint venturers and execute below in the appropriate manner. On Line (3), print or type the name of the other joint venturer and execute below in the appropriate manner. On Line (4), fill in the name of the third joint venturer, if applicable and execute below in the appropriate manner.

(1) Name of Joint Venture

(2) Name of Contractor

Address as prequalified

Signature of Witness or Attest By Signature of Contractor
Print or type Signer's name Print or type Signer's name

If Corporation, affix Corporate Seal and

(3) Name of Contractor

Address as prequalified

Signature of Witness or Attest By Signature of Contractor
Print or type Signer's name Print or type Signer's name

If Corporation, affix Corporate Seal and

(4) Name of Contractor (for 3 Joint Venture only)

Address as prequalified

Signature of Witness or Attest By Signature of Contractor
Print or type Signer's name Print or type Signer's name

If Corporation, affix Corporate Seal

NOTARY SEAL
Affidavit must be notarized for Line (2)
Subscribed and sworn to before me this
day of 20
Signature of Notary Public
of County
State of
My Commission Expires:

NOTARY SEAL
Affidavit must be notarized for Line (3)
Subscribed and sworn to before me this
day of 20
Signature of Notary Public
of County
State of
My Commission Expires:

NOTARY SEAL
Affidavit must be notarized for Line (4)
Subscribed and sworn to before me this
day of 20
Signature of Notary Public
of County
State of
My Commission Expires:

**EXECUTION OF BID
NON-COLLUSION AFFIDAVIT, DEBARMENT CERTIFICATION AND GIFT BAN CERTIFICATION**

INDIVIDUAL DOING BUSINESS UNDER A FIRM NAME

The person executing the bid, on behalf of the Bidder, being duly sworn, solemnly swears (or affirms) that neither he, nor any official, agent or employee of the bidder has entered into any agreement, participated in any collusion, or otherwise taken any action which is in restraint of free competitive bidding in connection with any bid or contract, that the bidder has not been convicted of violating *N.C.G.S. § 133-24* within the last three years, and that the Bidder intends to do the work with its own bonafide employees or subcontractors and is not bidding for the benefit of another contractor.

In addition, execution of this bid in the proper manner also constitutes the Bidder's certification of status under penalty of perjury under the laws of the United States in accordance with the Debarment Certification attached, provided that the Debarment Certification also includes any required statements concerning exceptions that are applicable.

N.C.G.S. § 133-32 and Executive Order 24 prohibit the offer to, or acceptance by, any State Employee of any gift from anyone with a contract with the State, or from any person seeking to do business with the State. By execution of any response in this procurement, you attest, for your entire organization and its employees or agents, that you are not aware that any such gift has been offered, accepted, or promised by any employees of your organization.

SIGNATURE OF CONTRACTOR

Name of Contractor

_____ Individual name

Trading and doing business as

_____ Full name of Firm

_____ Address as Prequalified

_____ Signature of Witness

_____ Signature of Contractor, Individually

_____ Print or type Signer's name

_____ Print or type Signer's name

AFFIDAVIT MUST BE NOTARIZED

Subscribed and sworn to before me this the
____ day of _____ 20__.

Signature of Notary Public
of _____ County
State of _____
My Commission Expires: _____

NOTARY SEAL

**EXECUTION OF BID
NON-COLLUSION AFFIDAVIT, DEBARMENT CERTIFICATION AND GIFT BAN CERTIFICATION**

INDIVIDUAL DOING BUSINESS IN HIS OWN NAME

The person executing the bid, on behalf of the Bidder, being duly sworn, solemnly swears (or affirms) that neither he, nor any official, agent or employee of the bidder has entered into any agreement, participated in any collusion, or otherwise taken any action which is in restraint of free competitive bidding in connection with any bid or contract, that the bidder has not been convicted of violating *N.C.G.S. § 133-24* within the last three years, and that the Bidder intends to do the work with its own bonafide employees or subcontractors and is not bidding for the benefit of another contractor.

In addition, execution of this bid in the proper manner also constitutes the Bidder's certification of status under penalty of perjury under the laws of the United States in accordance with the Debarment Certification attached, provided that the Debarment Certification also includes any required statements concerning exceptions that are applicable.

N.C.G.S. § 133-32 and Executive Order 24 prohibit the offer to, or acceptance by, any State Employee of any gift from anyone with a contract with the State, or from any person seeking to do business with the State. By execution of any response in this procurement, you attest, for your entire organization and its employees or agents, that you are not aware that any such gift has been offered, accepted, or promised by any employees of your organization.

SIGNATURE OF CONTRACTOR

Name of Contractor _____
Print or type Individual name

Address as Prequalified

Signature of Contractor, Individually

Print or type Signer's Name

Signature of Witness

Print or type Signer's name

AFFIDAVIT MUST BE NOTARIZED

Subscribed and sworn to before me this the
____ day of _____ 20__.

Signature of Notary Public
of _____ County
State of _____
My Commission Expires: _____

NOTARY SEAL

DEBARMENT CERTIFICATION

Conditions for certification:

1. The prequalified bidder shall provide immediate written notice to the Department if at any time the bidder learns that his certification was erroneous when he submitted his debarment certification or explanation that is file with the Department, or has become erroneous because of changed circumstances.
2. The terms *covered transaction, debarred, suspended, ineligible, lower tier covered transaction, participant, person, primary covered transaction, principal, proposal, and voluntarily excluded*, as used in this provision, have the meanings set out in the Definitions and Coverage sections of the rules implementing Executive Order 12549. A copy of the Federal Rules requiring this certification and detailing the definitions and coverages may be obtained from the Contract Officer of the Department.
3. The prequalified bidder agrees by submitting this form, that he will not knowingly enter into any lower tier covered transaction with a person who is debarred, suspended, declared ineligible, or voluntarily excluded from participation in NCDOT contracts, unless authorized by the Department.
4. For Federal Aid projects, the prequalified bidder further agrees that by submitting this form he will include the Federal-Aid Provision titled *Required Contract Provisions Federal-Aid Construction Contract (Form FHWA PR 1273)* provided by the Department, without subsequent modification, in all lower tier covered transactions.
5. The prequalified bidder may rely upon a certification of a participant in a lower tier covered transaction that he is not debarred, suspended, ineligible, or voluntarily excluded from the covered transaction, unless he knows that the certification is erroneous. The bidder may decide the method and frequency by which he will determine the eligibility of his subcontractors.
6. Nothing contained in the foregoing shall be construed to require establishment of a system of records in order to render in good faith the certification required by this provision. The knowledge and information of a participant is not required to exceed that which is normally possessed by a prudent person in the ordinary course of business dealings.
7. Except as authorized in paragraph 6 herein, the Department may terminate any contract if the bidder knowingly enters into a lower tier covered transaction with a person who is suspended, debarred, ineligible, or voluntarily excluded from participation in this transaction, in addition to other remedies available by the Federal Government.

DEBARMENT CERTIFICATION

The prequalified bidder certifies to the best of his knowledge and belief, that he and his principals:

- a. Are not presently debarred, suspended, proposed for debarment, declared ineligible, or voluntarily excluded from covered transactions by any Federal department or agency;
- b. Have not within a three-year period preceding this proposal been convicted of or had a civil judgment rendered against them for commission of fraud or a criminal offense in connection with obtaining, attempting to obtain, or performing a public (Federal, State or local) transaction or contract under a public transaction; violation of Federal or State antitrust statutes or commission of embezzlement, theft, forgery, bribery, falsification or destruction of records; making false statements; or receiving stolen property;
- c. Are not presently indicted for or otherwise criminally or civilly charged by a governmental entity (Federal, State or local) with commission of any of the offenses enumerated in paragraph b. of this certification; and
- d. Have not within a three-year period preceding this proposal had one or more public transactions (Federal, State or local) terminated for cause or default.
- e. Will submit a revised Debarment Certification immediately if his status changes and will show in his bid proposal an explanation for the change in status.

If the prequalified bidder cannot certify that he is not debarred, he shall provide an explanation with this submittal. An explanation will not necessarily result in denial of participation in a contract.

Failure to submit a non-collusion affidavit and debarment certification will result in the prequalified bidder's bid being considered non-responsive.

Check here if an explanation is attached to this certification.

Contract No **C 202831(R-4902)**

County (ies): **(Mecklenburg)**

ACCEPTED BY THE
DEPARTMENT OF TRANSPORTATION

Contract Officer

Date

Execution of Contract and Bonds
Approved as to Form:

Attorney General