

**This electronic collection of documents is provided
for the convenience of the user
and is Not a Certified Document –**

**The documents contained herein were originally issued
and sealed by the individuals whose names and license
numbers appear on each page, on the dates appearing
with their signature on that page.**

**This file or an individual page
shall not be considered a certified document.**

TIP PROJECT: B-5806

CONTRACT: DJ00430

See Sheet 1A For Index of Sheets
See Sheet 1B For Standard Symbology Sheet

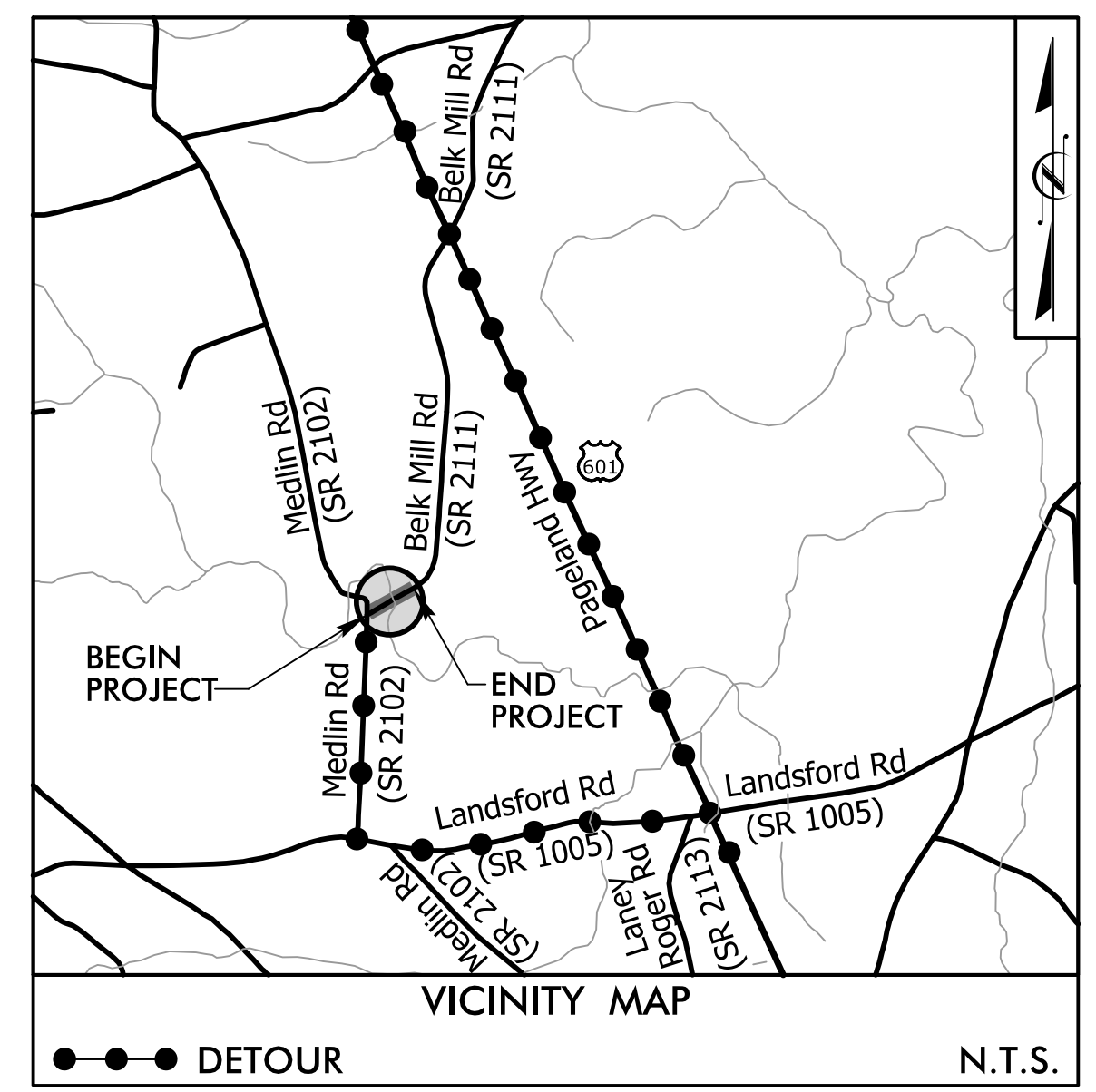

FINAL PLANS

STATE OF NORTH CAROLINA
DIVISION OF HIGHWAYS
UNION COUNTY

**LOCATION: BRIDGE #129 OVER LANES CREEK
ON SR 2111 (BELK MILL RD)**
TYPE OF WORK: GRADING, PAVING, DRAINAGE, & STRUCTURE

STATE	STATE PROJECT REFERENCE NO.	SHEET NO.	TOTAL SHEETS
N.C.	B-5806	1	
STATE PROJ. NO.	F.A. PROJ. NO.	DESCRIPTION	
45760.1.1		P.E.	
45760.2.1		ROW & UTIL	
45760.3.1		CONSTRUCTION	

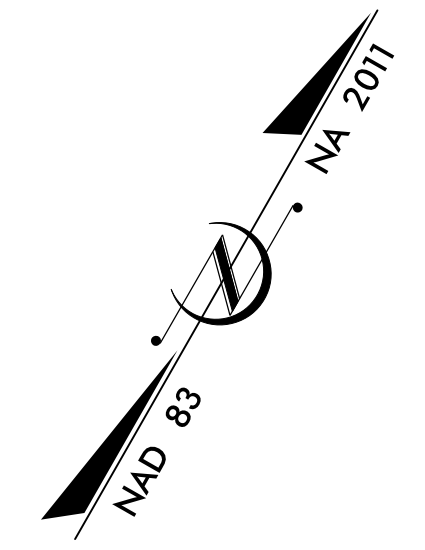
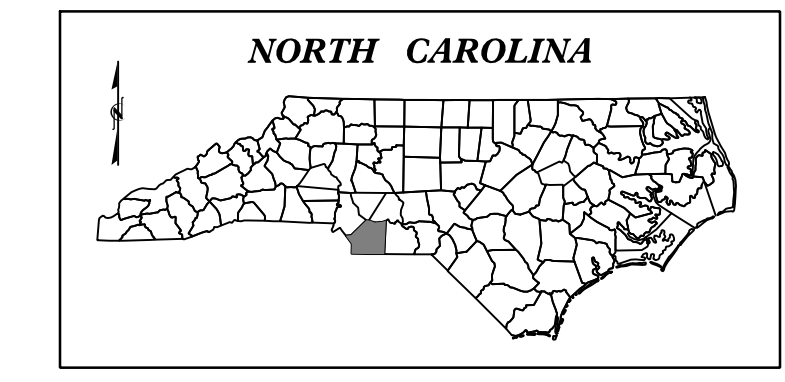

BEGIN TIP PROJECT B-5806
-L- STA. 12 + 00.00

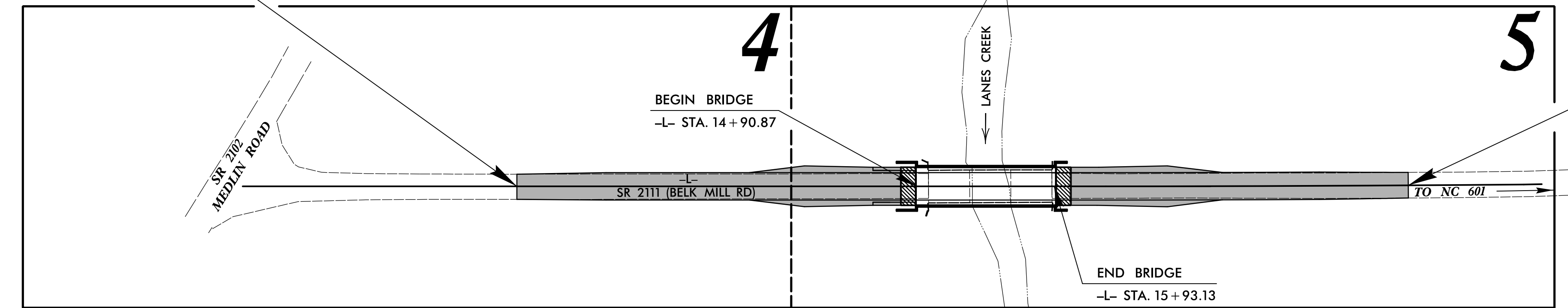

END TIP PROJECT B-5806
-L- STA. 18 + 50.00

**DOCUMENT NOT CONSIDERED FINAL
UNLESS ALL SIGNATURES COMPLETED**

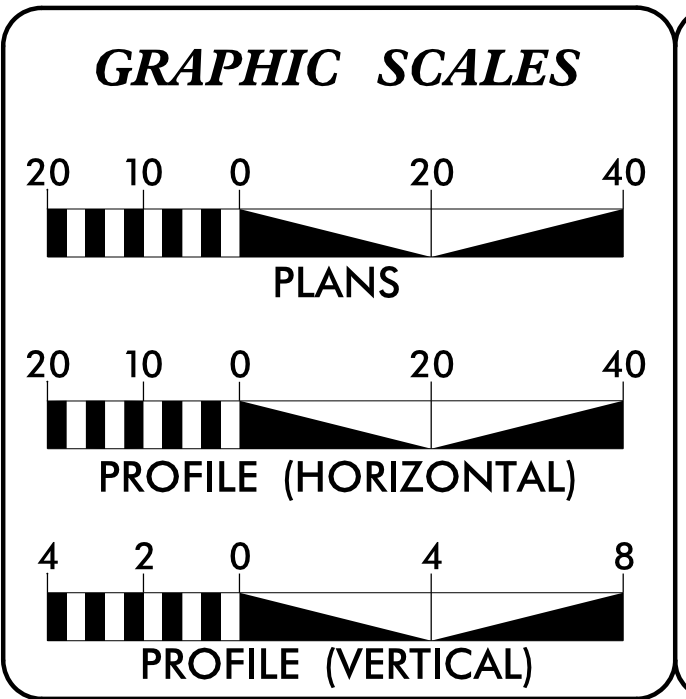

DESIGN DATA

ADT 2015 =	170
ADT 2025 =	340
DHV =	N/A
D =	N/A
T =	6%
V =	55 MPH
FUNC. CLASSIFICATION:	
LOCAL	
SUBREGIONAL TIER	

PROJECT LENGTH

LENGTH OF ROADWAY PROJECT TIP B-5806 = 0.104 MILES
LENGTH OF STRUCTURE PROJECT TIP B-5806 = 0.019 MILES
TOTAL LENGTH OF PROJECT TIP B-5806 = 0.123 MILES

NCDOT CONTACT: GARLAND HAYWOOD, PE
Division Bridge Manager

PLANS PREPARED FOR THE NCDOT BY:

STV 100 Years
STV Engineers, Inc.
900 West Trade St., Suite 715
Charlotte, NC 28202
NC License Number F-0991

2018 STANDARD SPECIFICATIONS

RIGHT OF WAY DATE: JUNE 21, 2019	NIKKI T. HONEYCUTT, PE PROJECT ENGINEER
LETTING DATE: AUGUST 17, 2022	CLARK GROVES PROJECT DESIGNER

HYDRAULICS ENGINEER

[Signature]

ROADWAY DESIGN ENGINEER

[Signature]



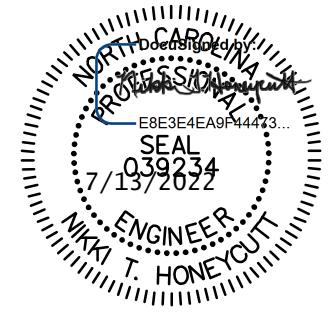

STV Engineers, Inc.
 800 West Trade St., Suite 715
 Charlotte, NC 28202
 NC License Number F-0991

PROJECT REFERENCE NO.	SHEET NO.
B-5806	1A
RW SHEET NO.	
ROADWAY DESIGN ENGINEER	
	
DOCUMENT NOT CONSIDERED FINAL UNLESS ALL SIGNATURES COMPLETED	

INDEX OF SHEETS

SHEET NUMBER	SHEET
1	TITLE SHEET
1A	INDEX OF SHEETS, GENERAL NOTES, AND LIST OF STANDARD DRAWINGS
1B	CONVENTIONAL SYMBOLS
2C-1 THRU 2C-2	ROADWAY DETAILS SHEETS
3	SUMMARIES AND TYPICAL SECTIONS SHEET
4 THRU 7	PLAN AND PROFILE SHEET
TMP-1 THRU TMP-2	TRANSPORTATION MANAGEMENT PLANS
PMP-1	PAVEMENT MARKING PLANS
EC-1 THRU EC-7	EROSION CONTROL PLANS
X-1 THRU X-8	CROSS-SECTIONS
S-1 THRU S-15	STRUCTURE PLANS
SN	STRUCTURE NOTES

GENERAL NOTES

GENERAL NOTES:

2018 SPECIFICATIONS
 EFFECTIVE: 01-01-2018

**GRADE LINE:
 GRADING AND SURFACING:**

THE GRADE LINES SHOWN DENOTE THE FINISHED ELEVATION OF THE PROPOSED SURFACING AT GRADE POINTS SHOWN ON THE TYPICAL SECTIONS. GRADE LINES MAY BE ADJUSTED AT THEIR BEGINNING AND ENDING AND AT STRUCTURES AS DIRECTED BY THE ENGINEER IN ORDER TO SECURE A PROPER TIE-IN.

CLEARING:

CLEARING ON THIS PROJECT SHALL BE PERFORMED TO THE LIMITS ESTABLISHED BY METHOD II.

SUPERELEVATION:

ALL CURVES ON THIS PROJECT SHALL BE SUPERELEVATED IN ACCORDANCE WITH STD. NO. 225.04 USING THE RATE OF SUPERELEVATION AND RUNOFF SHOWN ON THE PLANS. SUPERELEVATION IS TO BE REVOLVED ABOUT THE GRADE POINTS SHOWN ON THE TYPICAL SECTIONS.

SHOULDER CONSTRUCTION:

ASPHALT, EARTH, AND CONCRETE SHOULDER CONSTRUCTION ON THE HIGH SIDE OF SUPERELEVATED CURVES SHALL BE IN ACCORDANCE WITH STD. NO. 560.01.

GUARDRAIL:

THE GUARDRAIL LOCATIONS SHOWN ON THE PLANS MAY BE ADJUSTED DURING CONSTRUCTION AS DIRECTED BY THE ENGINEER. THE CONTRACTOR SHOULD CONSULT WITH THE ENGINEER PRIOR TO ORDERING GUARDRAIL MATERIAL.

END BENTS:

THE ENGINEER SHALL CHECK THE STRUCTURE END BENT PLANS, DETAILS, AND CROSS-SECTION PRIOR TO SETTING OF THE SLOPE STAKES FOR THE EMBANKMENT OR EXCAVATION APPROACHING A BRIDGE.

RIGHT-OF-WAY MARKERS:

ALL RIGHT-OF-WAY MARKERS ON THIS PROJECT SHALL BE PLACED BY THE DIVISION.

STANDARD DRAWINGS

2018 ROADWAY ENGLISH STANDARD DRAWINGS
 EFF. January, 2018





The following Roadway Standards as appear in "Roadway Standard Drawings" Highway Design Branch - N. C. Department of Transportation - Raleigh, N. C., Dated January, 2018 are applicable to this project and by reference hereby are considered a part of these plans:

STD.NO.	TITLE
DIVISION 2 - EARTHWORK	
200.02	Method of Clearing - Method II
225.02	Guide for Grading Subgrade - Secondary and Local
225.04	Method of Obtaining Superelevation - Two Lane Pavement
DIVISION 4 - MAJOR STRUCTURES	
422.02	Type II - Modified Approach Fill
DIVISION 5 - SUBGRADE, BASES AND SHOULDERS	
560.01	Method of Shoulder Construction - High Side of Superelevated Curve - Method I
DIVISION 8 - INCIDENTALS	
840.02	Concrete Catch Basin
840.03	Frame, Grates, and Hood
840.29	Frame and Narrow Slot Flat Grates
840.35	Traffic Bearing Grated Drop Inlet
846.01	Concrete Curb, Gutter and Curb & Gutter
862.01	Guardrail Placement
862.02	Guardrail Installation
876.02	Guide for Rip Rap at Pipe Outlets
DIVISION 11 - WORK ZONE TRAFFIC CONTROL	
1101.03	Temporary Road Closures
1110.01	Stationary Work Zone Signs - Mounting Height & Lateral Clearance
1145.01	Barricades - Type III







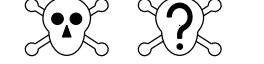

STATE OF NORTH CAROLINA, DIVISION OF HIGHWAYS CONVENTIONAL PLAN SHEET SYMBOLS

Note: Not to Scale



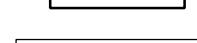

BOUNDARIES AND PROPERTY:

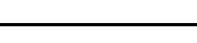
State Line	_____
County Line	_____
Township Line	_____
City Line	_____
Reservation Line	_____
Property Line	_____
Existing Iron Pin (EIP)	
Computed Property Corner	
Existing Concrete Monument (ECM)	
Parcel/Sequence Number	
Existing Fence Line	—X—X—X—
Proposed Woven Wire Fence	—○—
Proposed Chain Link Fence	—□—
Proposed Barbed Wire Fence	—◇—
Existing Wetland Boundary	—WLB—
Proposed Wetland Boundary	—WLB—
Existing Endangered Animal Boundary	—EAB—
Existing Endangered Plant Boundary	—EPB—
Existing Historic Property Boundary	—HPB—
Known Contamination Area: Soil	—S—S—S—
Potential Contamination Area: Soil	—S—S—S—
Known Contamination Area: Water	—W—W—W—
Potential Contamination Area: Water	—W—W—W—
Contaminated Site: Known or Potential	

BUILDINGS AND OTHER CULTURE:

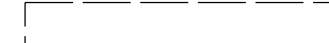
Gas Pump Vent or U/G Tank Cap	
Sign	
Well	
Small Mine	
Foundation	
Area Outline	
Cemetery	
Building	
School	
Church	
Dam	_____

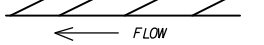











HYDROLOGY:

Stream or Body of Water	_____
Hydro, Pool or Reservoir	
Jurisdictional Stream	—JS—
Buffer Zone 1	—BZ 1—
Buffer Zone 2	—BZ 2—
Flow Arrow	←
Disappearing Stream	→
Spring	
Wetland	
Proposed Lateral, Tail, Head Ditch	
False Sump	





RAILROADS:



Standard Gauge	_____
RR Signal Milepost	
Switch	
RR Abandoned	_____
RR Dismantled	_____

RIGHT OF WAY & PROJECT CONTROL:





Primary Horiz Control Point	
Primary Horiz and Vert Control Point	
Secondary Horiz and Vert Control Point	
Vertical Benchmark	
Existing Right of Way Monument	
Proposed Right of Way Monument (Rebar and Cap)	
Proposed Right of Way Monument (Concrete)	
Existing Permanent Easement Monument	
Proposed Permanent Easement Monument (Rebar and Cap)	
Existing C/A Monument	
Proposed C/A Monument (Rebar and Cap)	
Proposed C/A Monument (Concrete)	
Existing Right of Way Line	_____
Proposed Right of Way Line	_____
Existing Control of Access Line	_____
Proposed Control of Access Line	_____
Proposed ROW and CA Line	_____
Existing Easement Line	_____
Proposed Temporary Construction Easement	_____
Proposed Temporary Drainage Easement	_____
Proposed Permanent Drainage Easement	_____
Proposed Permanent Drainage/Utility Easement	_____
Proposed Permanent Utility Easement	_____
Proposed Temporary Utility Easement	_____
Proposed Aerial Utility Easement	_____

ROADS AND RELATED FEATURES:

Existing Edge of Pavement	_____
Existing Curb	_____
Proposed Slope Stakes Cut	—C—
Proposed Slope Stakes Fill	—F—
Proposed Curb Ramp	
Existing Metal Guardrail	—T—T—T—
Proposed Guardrail	—T—T—T—
Existing Cable Guiderail	—□—□—□—
Proposed Cable Guiderail	—□—□—□—
Equality Symbol	
Pavement Removal	
VEGETATION:	
Single Tree	
Single Shrub	
Hedge	_____

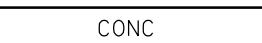

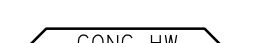







Woods Line	_____
Orchard	
Vineyard	

EXISTING STRUCTURES:







MAJOR:	
Bridge, Tunnel or Box Culvert	
Bridge Wing Wall, Head Wall and End Wall	
MINOR:	
Head and End Wall	
Pipe Culvert	_____
Footbridge	_____
Drainage Box: Catch Basin, DI or JB	
Paved Ditch Gutter	_____
Storm Sewer Manhole	
Storm Sewer	_____

UTILITIES:









* SUE - Subsurface Utility Engineering
LOS - Level of Service - A,B,C or D (Accuracy)

POWER:	
Existing Power Pole	
Proposed Power Pole	
Existing Joint Use Pole	
Proposed Joint Use Pole	
Power Manhole	
Power Line Tower	
Power Transformer	
U/G Power Cable Hand Hole	
H-Frame Pole	
U/G Power Line Test Hole (SUE - LOS A)*	
U/G Power Line (SUE - LOS B)*	_____
U/G Power Line (SUE - LOS C)*	_____
U/G Power Line (SUE - LOS D)*	_____



TELEPHONE:

Existing Telephone Pole	
Proposed Telephone Pole	
Telephone Manhole	
Telephone Pedestal	
Telephone Cell Tower	
U/G Telephone Cable Hand Hole	
U/G Telephone Test Hole (SUE - LOS A)*	
U/G Telephone Cable (SUE - LOS B)*	_____
U/G Telephone Cable (SUE - LOS C)*	_____
U/G Telephone Cable (SUE - LOS D)*	_____
U/G Telephone Conduit (SUE - LOS B)*	_____
U/G Telephone Conduit (SUE - LOS C)*	_____
U/G Telephone Conduit (SUE - LOS D)*	_____
U/G Fiber Optics Cable (SUE - LOS B)*	_____
U/G Fiber Optics Cable (SUE - LOS C)*	_____
U/G Fiber Optics Cable (SUE - LOS D)*	_____



WATER:

Water Manhole	
Water Meter	
Water Valve	
Water Hydrant	
U/G Water Line Test Hole (SUE - LOS A)*	
U/G Water Line (SUE - LOS B)*	_____
U/G Water Line (SUE - LOS C)*	_____
U/G Water Line (SUE - LOS D)*	_____
Above Ground Water Line	_____
TV:	
TV Pedestal	
TV Tower	
U/G TV Cable Hand Hole	
U/G TV Test Hole (SUE - LOS A)*	
U/G TV Cable (SUE - LOS B)*	_____
U/G TV Cable (SUE - LOS C)*	_____
U/G TV Cable (SUE - LOS D)*	_____
U/G Fiber Optic Cable (SUE - LOS B)*	_____
U/G Fiber Optic Cable (SUE - LOS C)*	_____
U/G Fiber Optic Cable (SUE - LOS D)*	_____











GAS:

Gas Valve	
Gas Meter	
U/G Gas Line Test Hole (SUE - LOS A)*	
U/G Gas Line (SUE - LOS B)*	_____
U/G Gas Line (SUE - LOS C)*	_____
U/G Gas Line (SUE - LOS D)*	_____
Above Ground Gas Line	_____

SANITARY SEWER:

Sanitary Sewer Manhole	
Sanitary Sewer Cleanout	
U/G Sanitary Sewer Line	_____
Above Ground Sanitary Sewer	_____
SS Force Main Line Test Hole (SUE - LOS A)*	
SS Force Main Line (SUE - LOS B)*	_____
SS Force Main Line (SUE - LOS C)*	_____
SS Force Main Line (SUE - LOS D)*	_____

MISCELLANEOUS:

Utility Pole	
Utility Pole with Base	
Utility Located Object	
Utility Traffic Signal Box	
Utility Unknown U/G Line (SUE - LOS B)*	_____
U/G Tank; Water, Gas, Oil	
Underground Storage Tank, Approx. Loc.	
A/G Tank; Water, Gas, Oil	
Geoenvironmental Boring	
Abandoned According to Utility Records	
End of Information	

PROJECT REFERENCE NO.	SHEET NO.
B-5806	2C-1
DOCUMENT NOT CONSIDERED FINAL UNLESS ALL SIGNATURES COMPLETED	

STATE OF
NORTH CAROLINA
DEPT. OF TRANSPORTATION
DIVISION OF HIGHWAYS
RALEIGH, N.C.

ROADWAY DETAIL DRAWING FOR
GUARDRAIL INSTALLATION

SHEET 6 OF 8
862D02

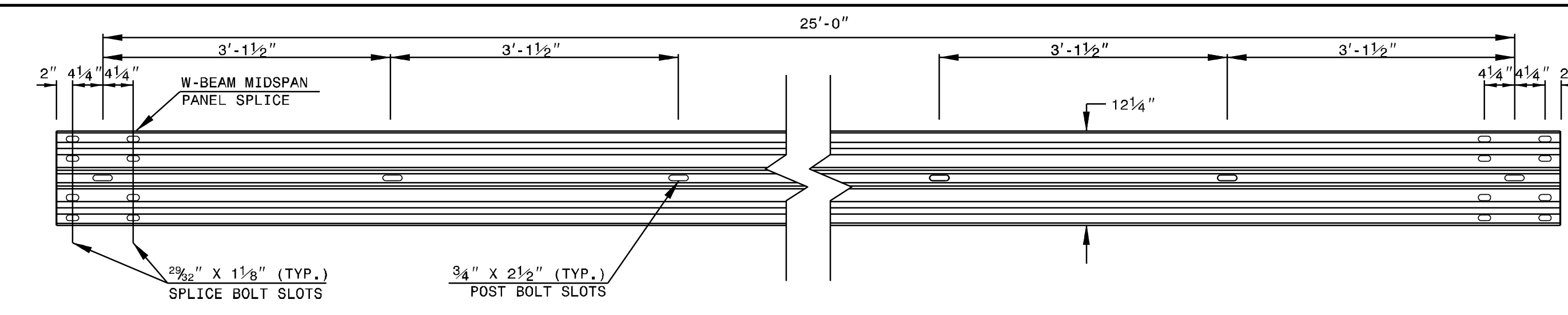

STANDARD W-BEAM GUARDRAIL

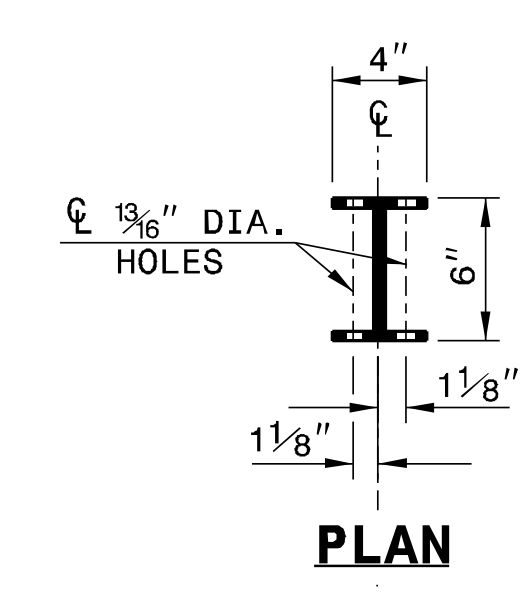

PLAN

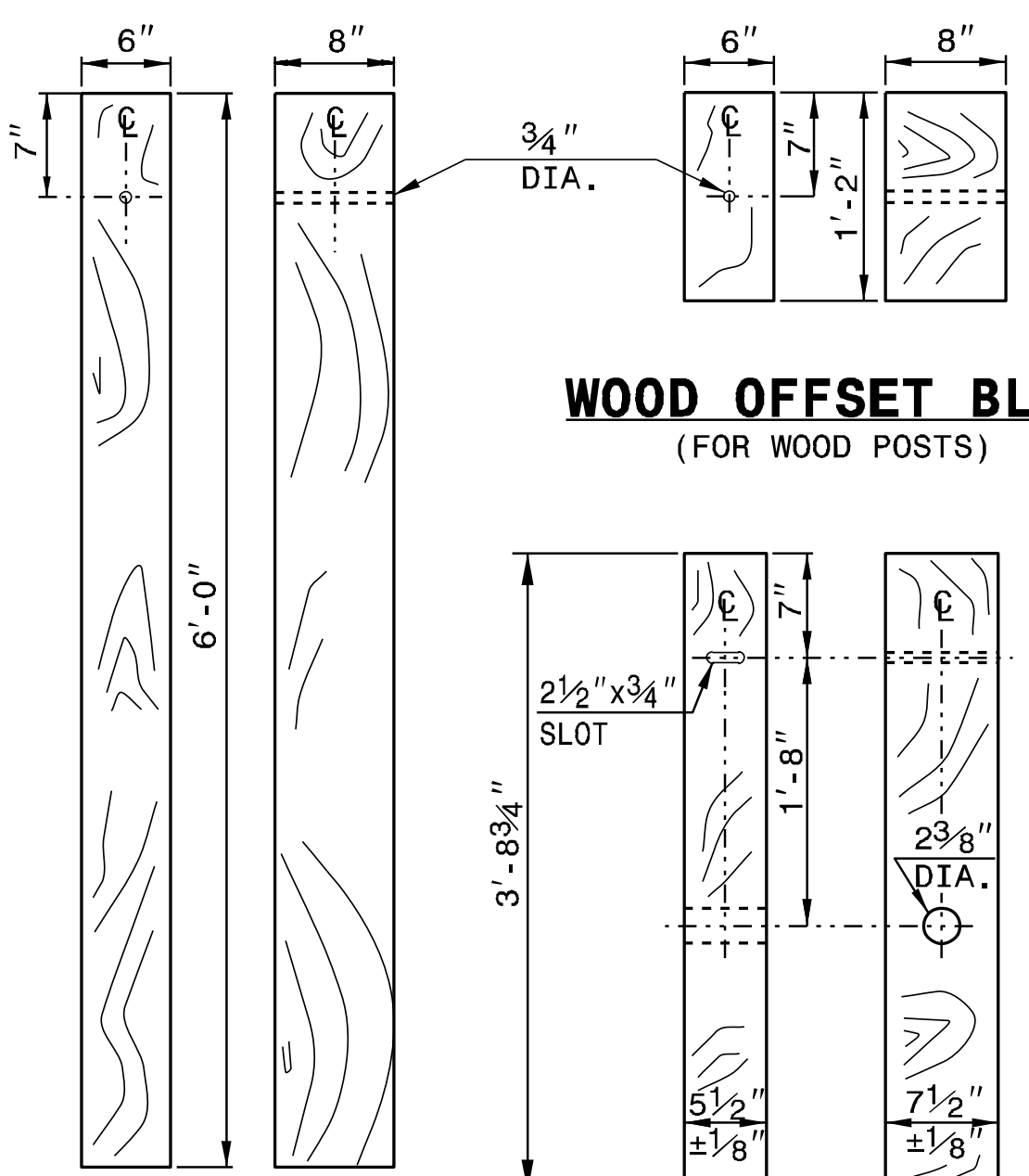

**WOOD OFFSET BLOCK
(FOR WOOD POSTS)**

**STANDARD
LINE POST**

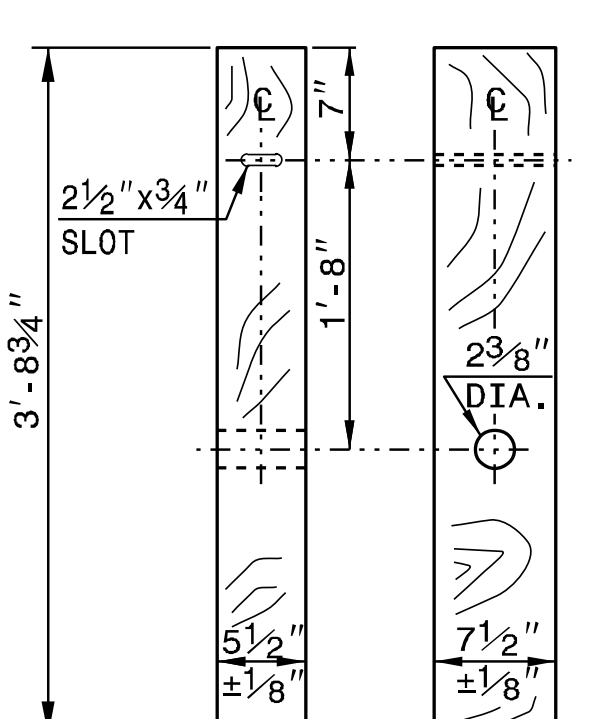

**SHORT WOOD
BREAKAWAY POST**

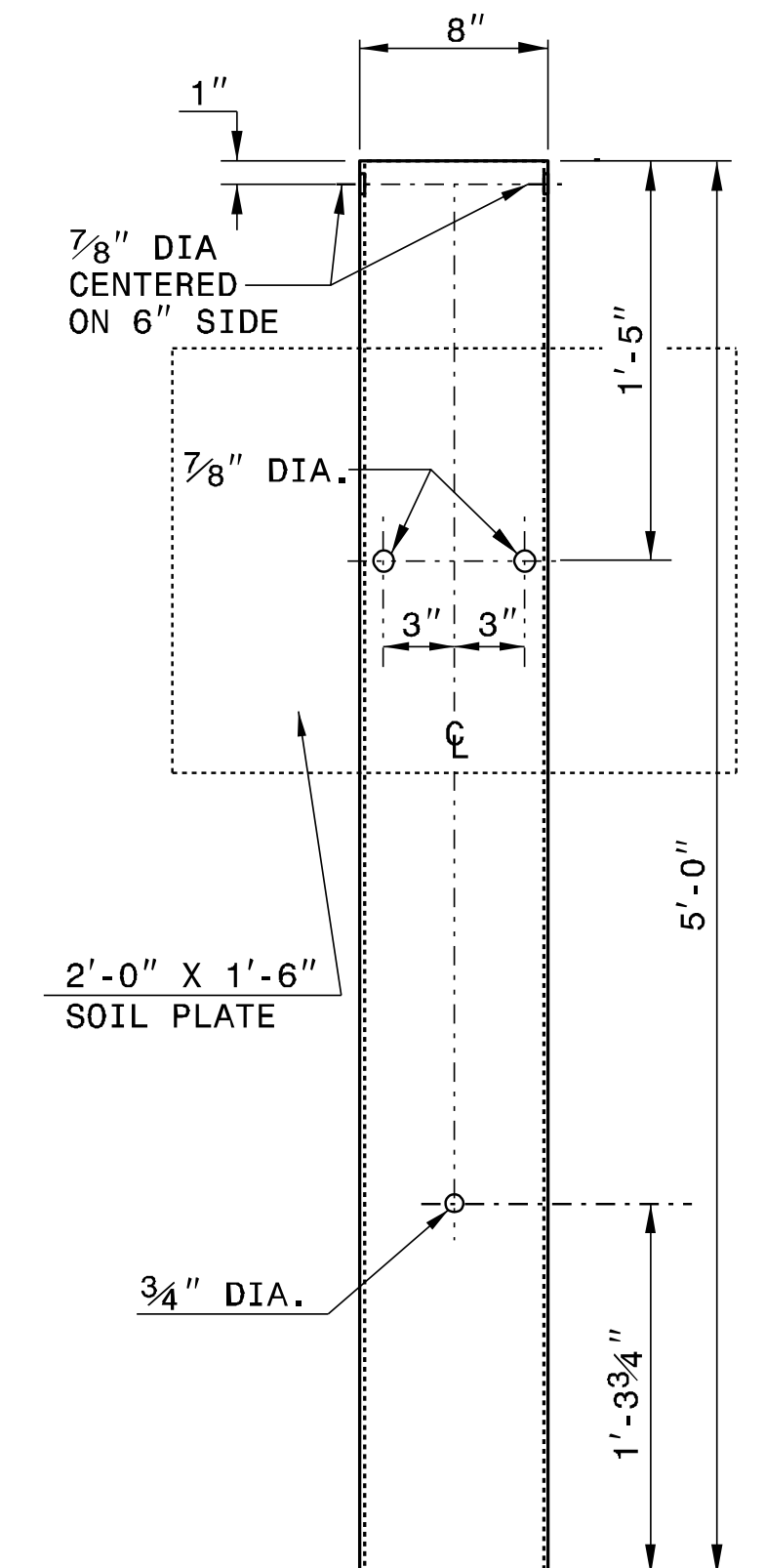

**STEEL TUBE
TS 6" x 8" x 0.1875"**

SYSTEM PARTS

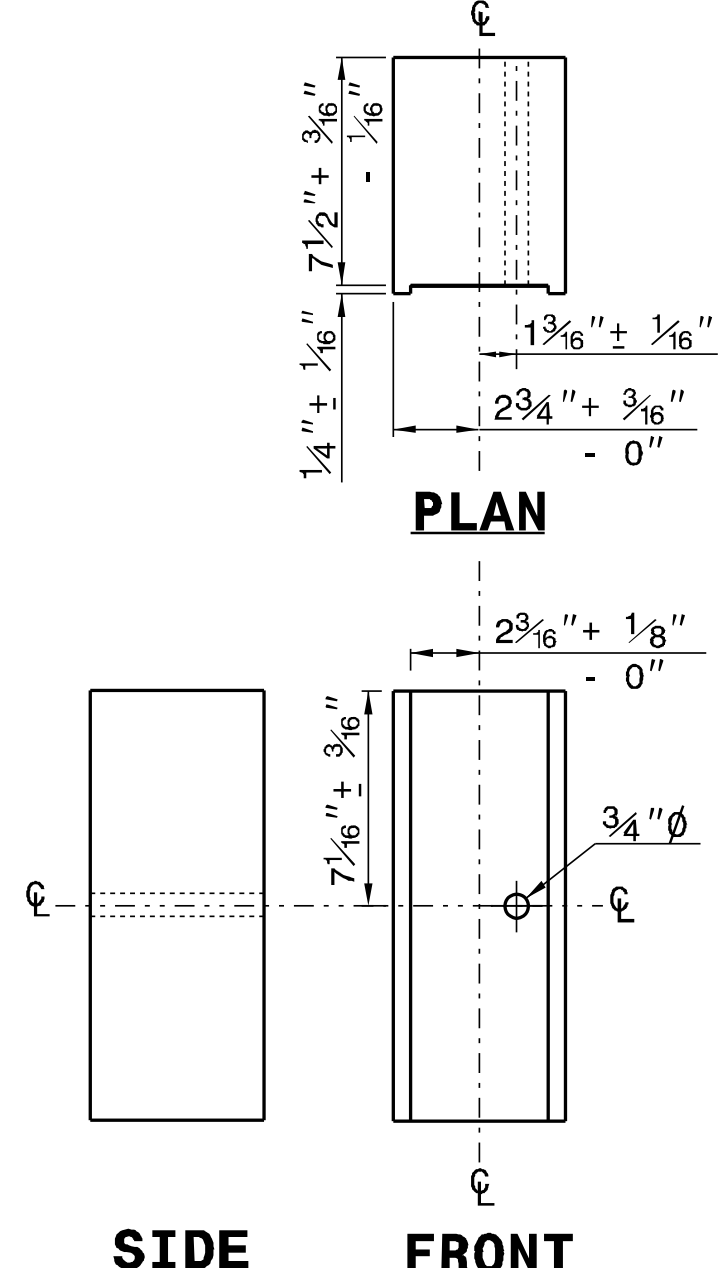

SIDE FRONT

**ROUTED
OFFSET BLOCK**

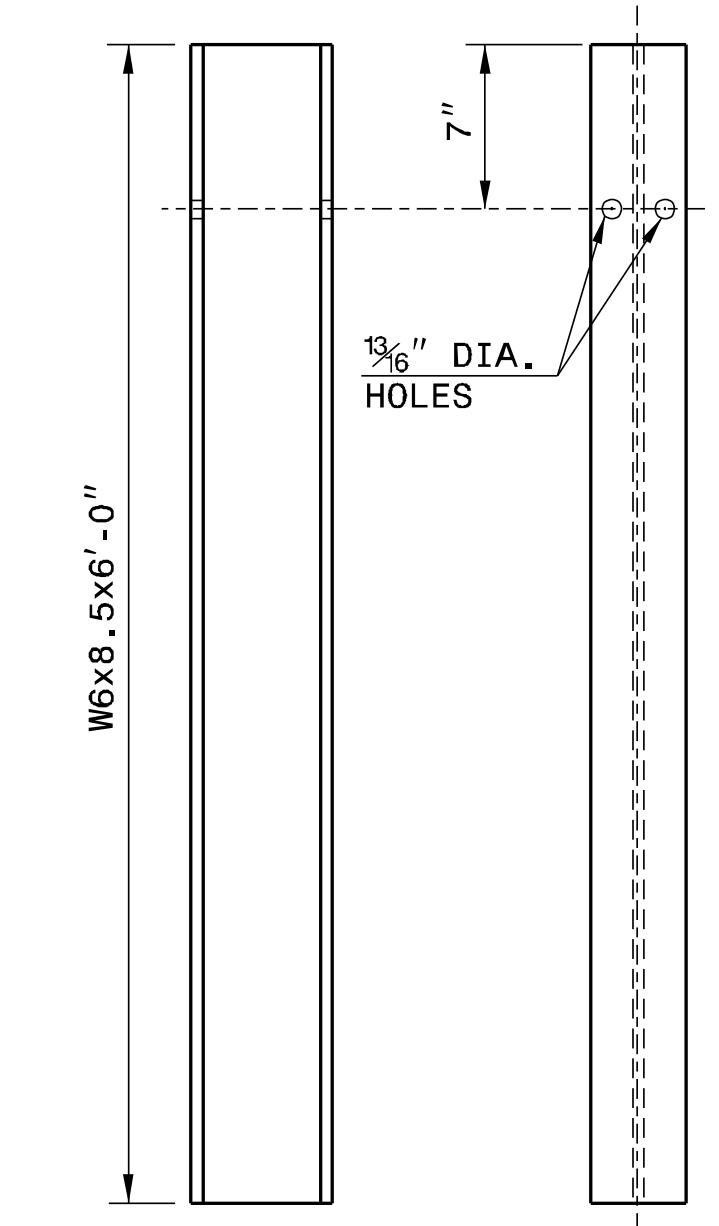

**SIDE FRONT
"W6" STEEL POST**

STATE OF
NORTH CAROLINA
DEPT. OF TRANSPORTATION
DIVISION OF HIGHWAYS
RALEIGH, N.C.

ROADWAY DETAIL DRAWING FOR
GUARDRAIL INSTALLATION

SHEET 6 OF 8
862D02



CONTRACTS STANDARDS AND DEVELOPMENT UNIT Office 919-707-6950 FAX 919-250-4119	
SEE TITLE BLOCK	
ORIGINAL BY: J. HOWERTON	DATE: 3-7-2018
MODIFIED BY:	DATE:
CHECKED BY:	DATE:
FILE SPEC.:	

14 DEC 2017 10:36
 S:\Contracts\2017\20170824\20170824.dgn
 Jhowerton

STATE OF NORTH CAROLINA DEPT. OF TRANSPORTATION DIVISION OF HIGHWAYS RALEIGH, N.C.	ROADWAY DETAIL DRAWING FOR STRUCTURE ANCHOR UNITS GUARDRAIL ANCHOR UNIT, TYPE III FOR ATTACHMENT TO RAIL ON BRIDGE	ROADWAY DETAIL DRAWING FOR STRUCTURE ANCHOR UNITS GUARDRAIL ANCHOR UNIT, TYPE III FOR ATTACHMENT TO RAIL ON BRIDGE
SHEET 1 OF 7 862D03	SHEET 1 OF 7 862D03	SHEET 1 OF 7 862D03

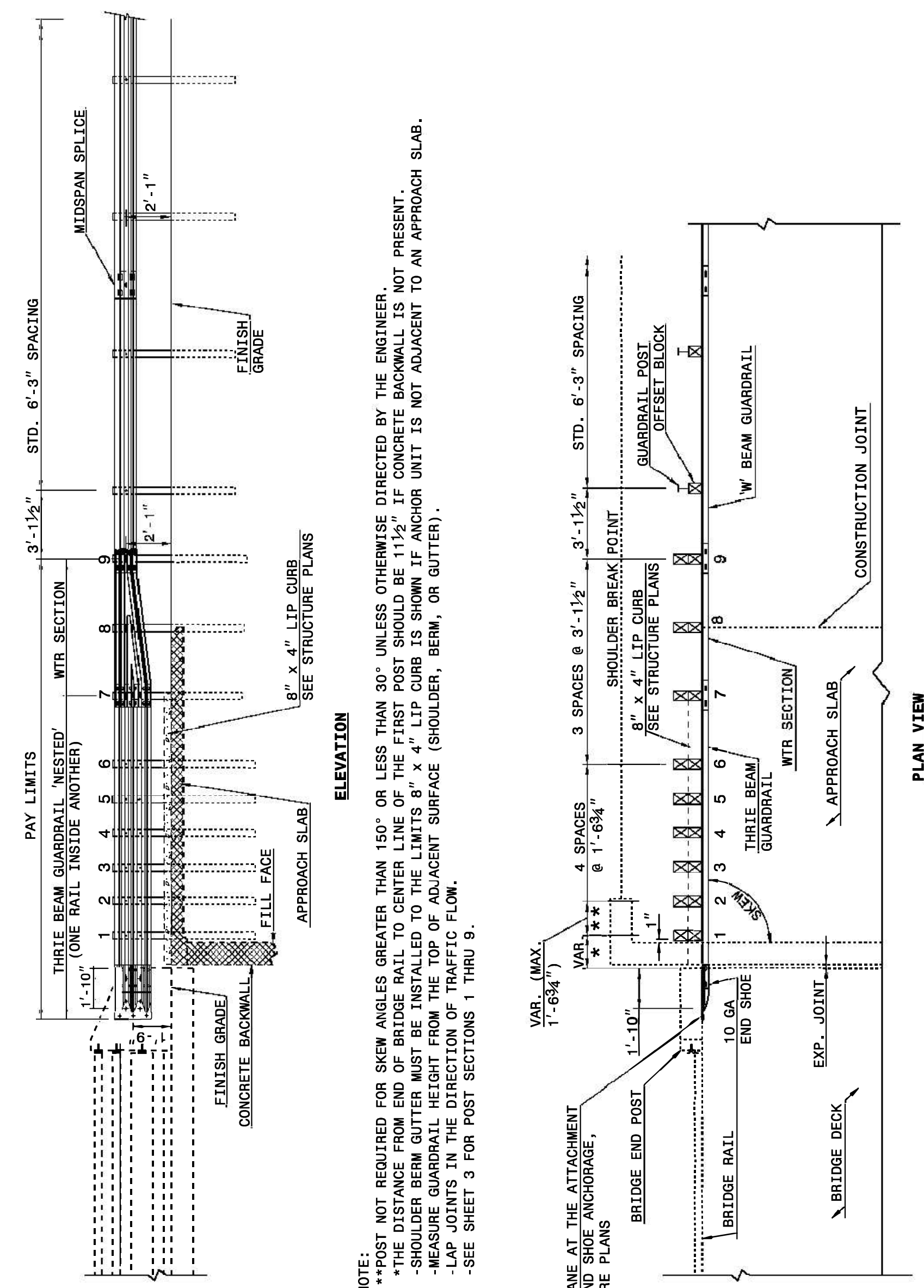

NOTE:

- **POST NOT REQUIRED FOR SKEW ANGLES GREATER THAN 150° OR LESS THAN 30° UNLESS OTHERWISE DIRECTED BY THE ENGINEER.
- *THE DISTANCE FROM END OF BRIDGE RAIL TO CENTER LINE OF THE FIRST POST SHOULD BE 11 1/2". IF CONCRETE BACKWALL IS NOT PRESENT.
- SHOULDER BERM GUTTER MUST BE INSTALLED TO THE LIMITS 8" X 4" LIP CURB IS SHOWN IF ANCHOR UNIT IS NOT ADJACENT TO AN APPROACH SLAB.
- MEASURE GUARDRAIL HEIGHT FROM THE TOP OF ADJACENT SURFACE (SHOULDER, BERM, OR GUTTER).
- LAP JOINTS IN THE DIRECTION OF TRAFFIC FLOW.
- SEE SHEET 3 FOR POST SECTIONS 1 THRU 9.

**GUARDRAIL ANCHOR UNIT, TYPE III
FOR ATTACHMENT TO RAIL ON BRIDGE**

STATE OF NORTH CAROLINA DEPT. OF TRANSPORTATION DIVISION OF HIGHWAYS RALEIGH, N.C.	ROADWAY DETAIL DRAWING FOR STRUCTURE ANCHOR UNITS GUARDRAIL ANCHOR UNIT, TYPE III FOR ATTACHMENT TO RAIL ON BRIDGE - SUB REGIONAL TIER	ROADWAY DETAIL DRAWING FOR STRUCTURE ANCHOR UNITS GUARDRAIL ANCHOR UNIT, TYPE III FOR ATTACHMENT TO RAIL ON BRIDGE - SUB REGIONAL TIER
SHEET 2 OF 7 862D03	SHEET 2 OF 7 862D03	SHEET 2 OF 7 862D03

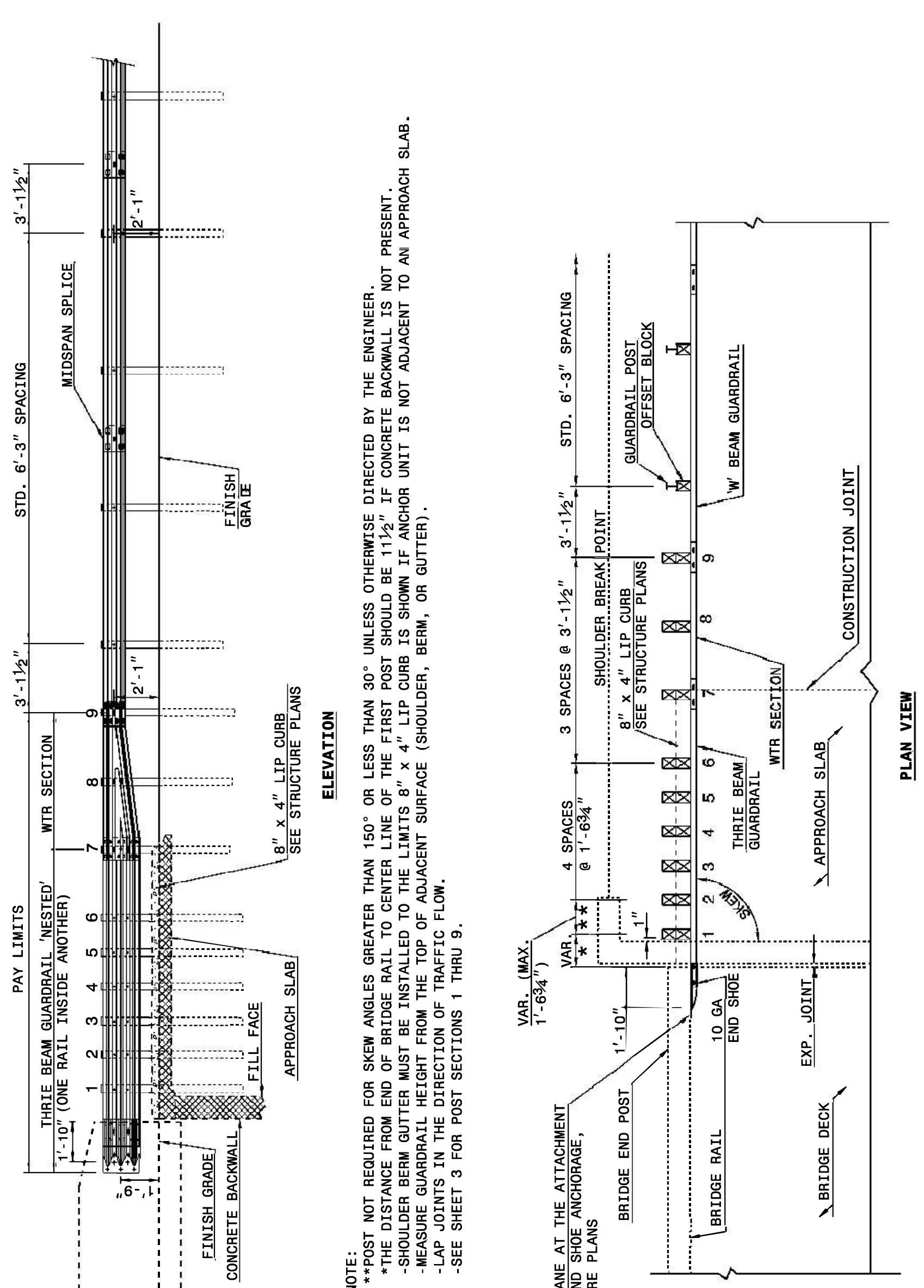

NOTE:

- **POST NOT REQUIRED FOR SKEW ANGLES GREATER THAN 150° OR LESS THAN 30° UNLESS OTHERWISE DIRECTED BY THE ENGINEER.
- *THE DISTANCE FROM END OF BRIDGE RAIL TO CENTER LINE OF THE FIRST POST SHOULD BE 11 1/2". IF CONCRETE BACKWALL IS NOT PRESENT.
- SHOULDER BERM GUTTER MUST BE INSTALLED TO THE LIMITS 8" X 4" LIP CURB IS SHOWN IF ANCHOR UNIT IS NOT ADJACENT TO AN APPROACH SLAB.
- MEASURE GUARDRAIL HEIGHT FROM THE TOP OF ADJACENT SURFACE (SHOULDER, BERM, OR GUTTER).
- LAP JOINTS IN THE DIRECTION OF TRAFFIC FLOW.
- SEE SHEET 3 FOR POST SECTIONS 1 THRU 9.

**GUARDRAIL ANCHOR UNIT, TYPE III FOR ATTACHMENT TO
RAIL ON BRIDGE - SUB REGIONAL TIER**

CONTRACT STANDARDS AND DEVELOPMENT UNIT Office 919-707-6950 FAX 919-250-4119	DOCUMENT NOT CONSIDERED FINAL UNLESS ALL SIGNATURES COMPLETED
SEE TITLE BLOCK	
ORIGINAL BY: J HOWERTON MODIFIED BY: CHECKED BY: FILE SPEC.:	DATE: 06-22-12 DATE: DATE: DATE:



12/06/2017

DIVISION OF HIGHWAYS
STATE OF NORTH CAROLINA

PROJECT REFERENCE NO. B-5806 SHEET NO. 3
ROADWAY DESIGN ENGINEER
PAVEMENT DESIGN ENGINEER
DOCUMENT NOT CONSIDERED FINAL UNLESS ALL SIGNATURES COMPLETED

PAVEMENT SCHEDULE table with rows C1, C2, D1, D2, E1, E2, R, T, U, W and corresponding material specifications.

ALL PAVEMENT SLOPES ARE 1:1 UNLESS SHOWN OTHERWISE.

SUMMARY OF EARTHWORK
(IN CUBIC YDS.)

Summary of earthwork table with columns for station, side, uncl. excav., embank. %, borrow, waste, and project totals.

DDE = 30 CY

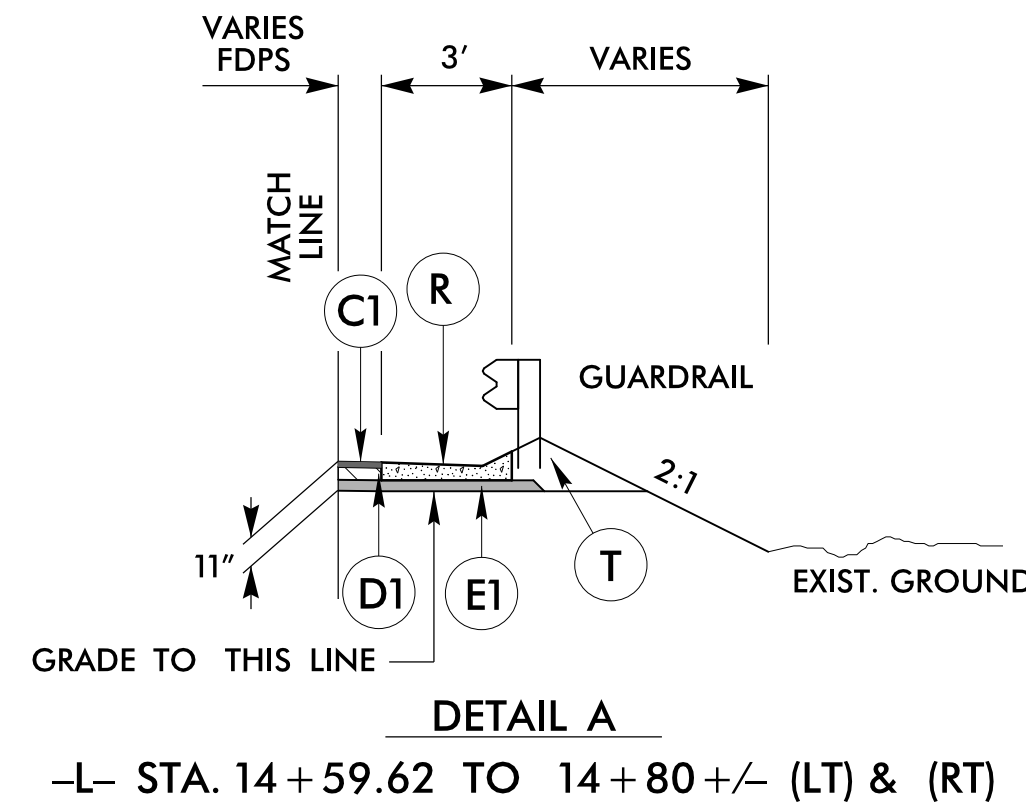
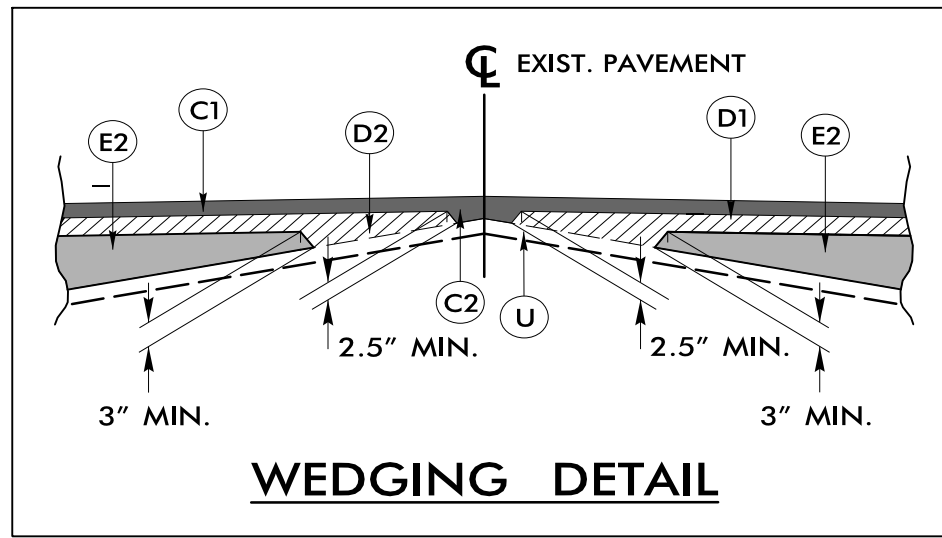

DETAIL A
-L- STA. 14 + 59.62 TO 14 + 80 +/- (LT) & (RT)

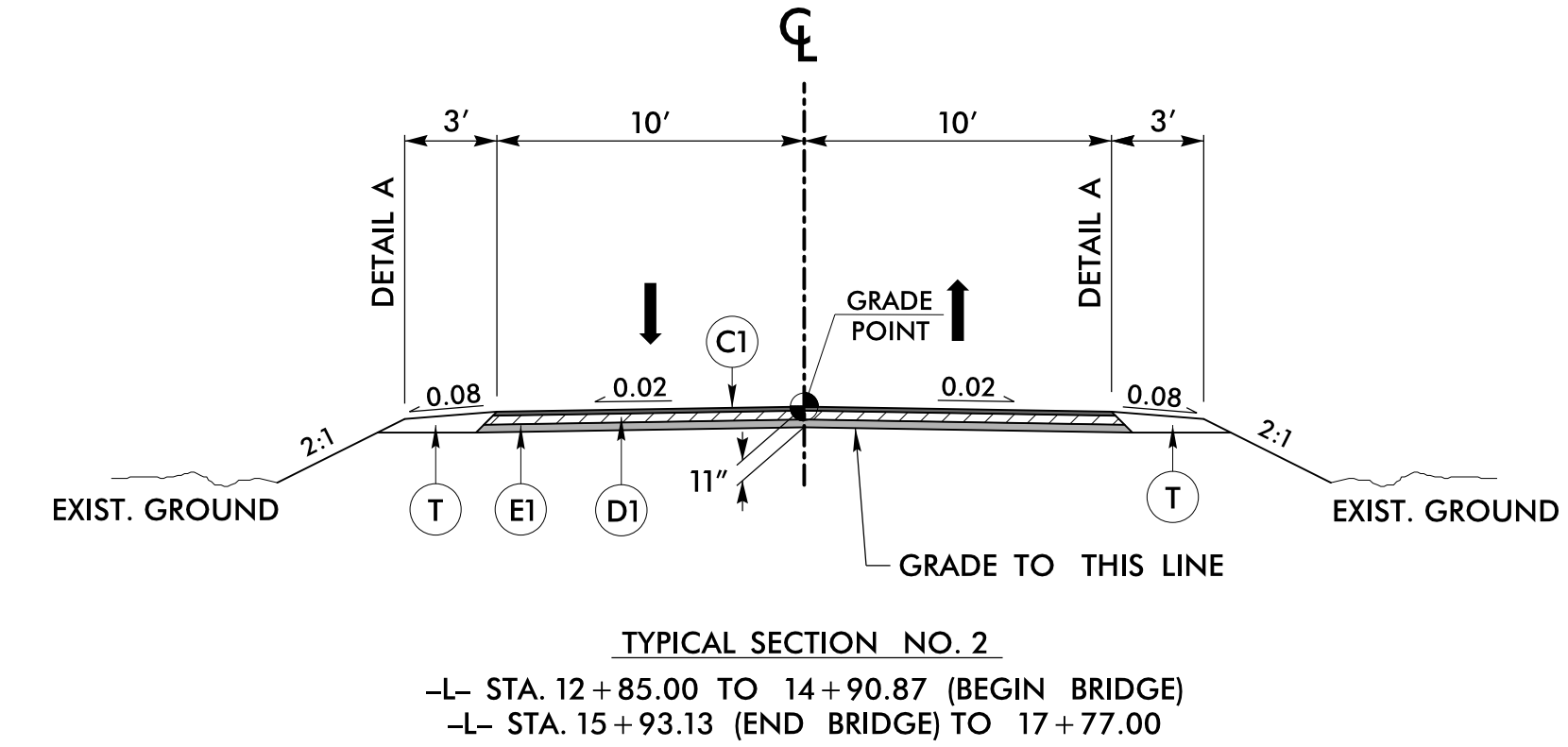
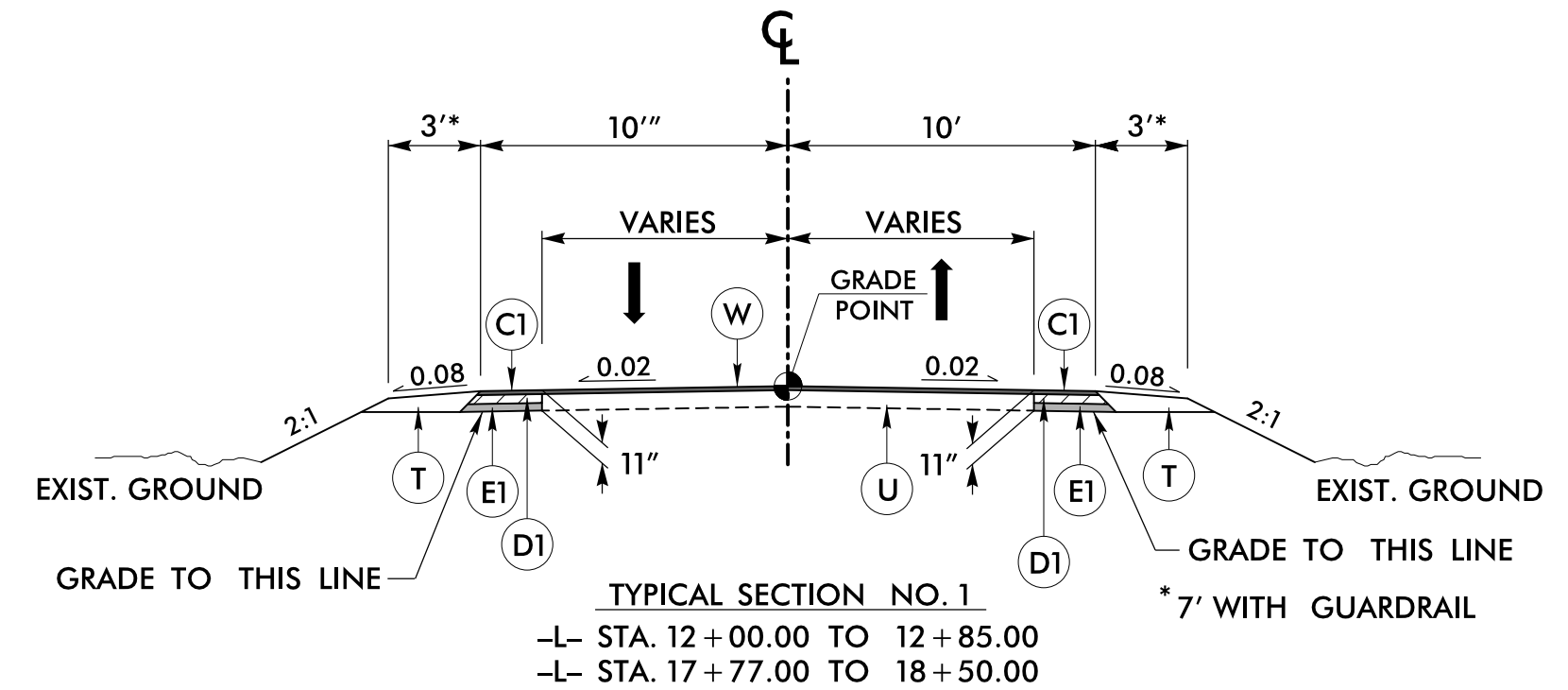

LIST OF PIPES, ENDWALLS, ETC. (FOR PIPES 48\"/>

Large table listing pipe details including station, location, structure no., invert elevations, pipe size, material, endwalls, grates, and remarks.

"N" = DISTANCE FROM EDGE OF LANE TO FACE OF GUARDRAIL.
TOTAL SHOULDER WIDTH = DISTANCE FROM EDGE OF TRAVEL LANE TO SHOULDER BREAK POINT.
FLARE LENGTH = DISTANCE FROM LAST SECTION OF PARALLEL GUARDRAIL TO END OF GUARDRAIL.

GUARDRAIL SUMMARY

Guardrail summary table with columns for survey line, length, warrant point, flare length, w, anchors, impact attenuator, and remarks.

7/27/2022 1:34:51 PM s:\proj\p01\sh1\B-5806-rdy-psh\03.dgn

8/17/22

DATUM DESCRIPTION

THE LOCALIZED COORDINATE SYSTEM DEVELOPED FOR THIS PROJECT IS BASED ON THE STATE PLANE COORDINATES ESTABLISHED BY OTHERS FOR MONUMENT "B5806-1" WITH NAD 83/NA 2011 STATE PLANE GRID COORDINATES OF NORTHING: 403168.4830(±) EASTING: 1564838.6510(±±) ELEVATION: 514.6530(±±)

THE AVERAGE COMBINED GRID FACTOR USED ON THIS PROJECT (GROUND TO GRID) IS: 0.999876618

THE N.C. LAMBERT GRID BEARING AND LOCALIZED HORIZONTAL GROUND DISTANCE FROM "B5806-1" TO -L- STATION IS 12+00.00 S 54°05'56.8" W 125.14'

ALL LINEAR DIMENSIONS ARE LOCALIZED HORIZONTAL DISTANCES VERTICAL DATUM USED IS NAVD 88

BM-1	N 403283	E 1564929	ELEV 509.95'
BM-2	N 403449	E 1565428	ELEV 537.45'
BL-3	N 402974.6790	E 1564534.0300	ELEV 533.40'
B5806-1	N 403168.4830	E 1564838.6510	ELEV 514.65'
B5806-2	N 403572.7760	E 1565557.1140	ELEV 542.43'

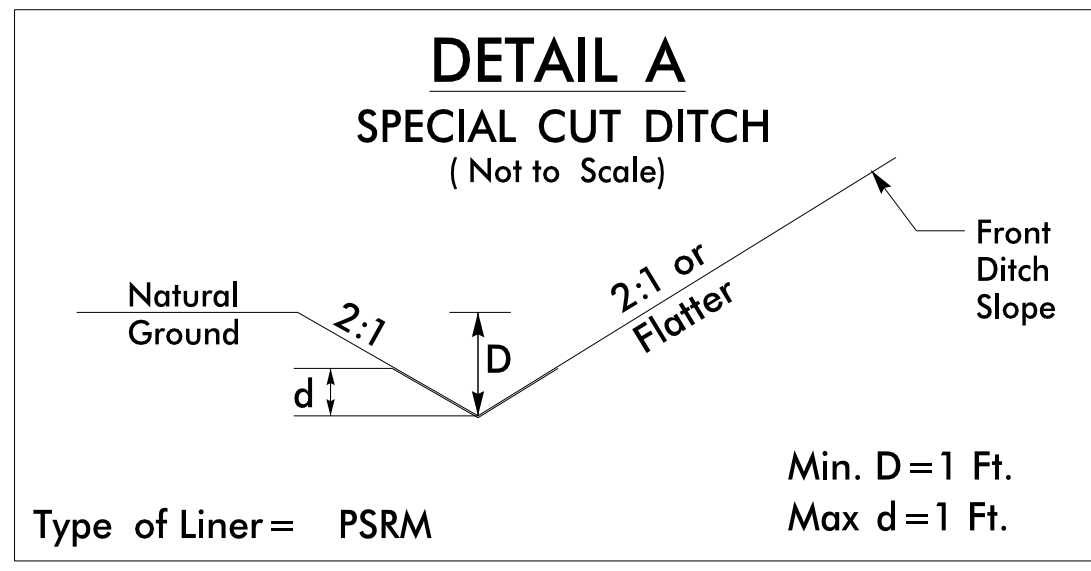

FROM STA. 13+00 LT TO STA. 14+48 LT

STV 100 Years
STV Engineers, Inc.
 300 West Trade St., Suite 715
 Charlotte, NC 28202
 NC License Number F-0991

PROJECT REFERENCE NO. B-5806		SHEET NO. 4	
RW SHEET NO.		HYDRAULICS ENGINEER	
ROADWAY DESIGN ENGINEER	ROADWAY DESIGN ENGINEER		HYDRAULICS ENGINEER
DOCUMENT NOT CONSIDERED FINAL UNLESS ALL SIGNATURES COMPLETED			

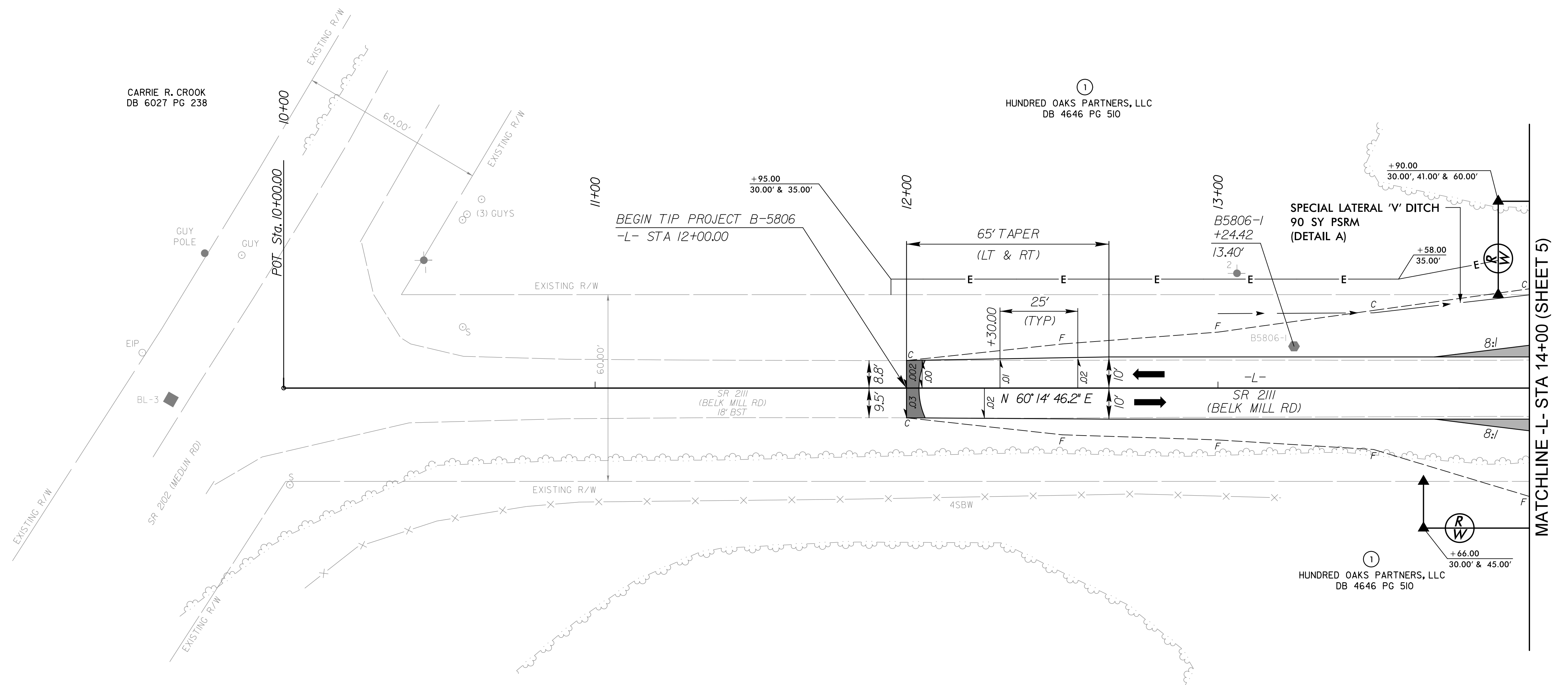
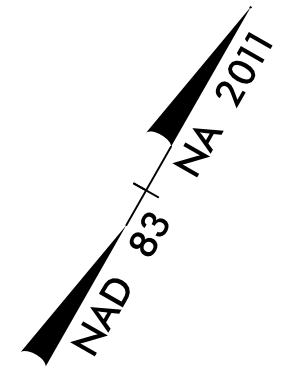

NOTE: INCIDENTAL MILL APPROXIMATELY 25' AT EACH TIE IN TO PROVIDE A SMOOTH TRANSITION TO THE EXISTING ASPHALT PAVEMENT.

SEE SHEET 6 FOR -L- PROFILE

7/12/2022
 R:\2022\proj\proj\sh\B-5806_r.dwg_psh04.dgn
 Sources

PROJECT REFERENCE NO. B-5806		SHEET NO. 5	
RW SHEET NO.		HYDRAULICS ENGINEER	
ROADWAY DESIGN ENGINEER		HYDRAULICS ENGINEER	
DOCUMENT NOT CONSIDERED FINAL UNLESS ALL SIGNATURES COMPLETED			

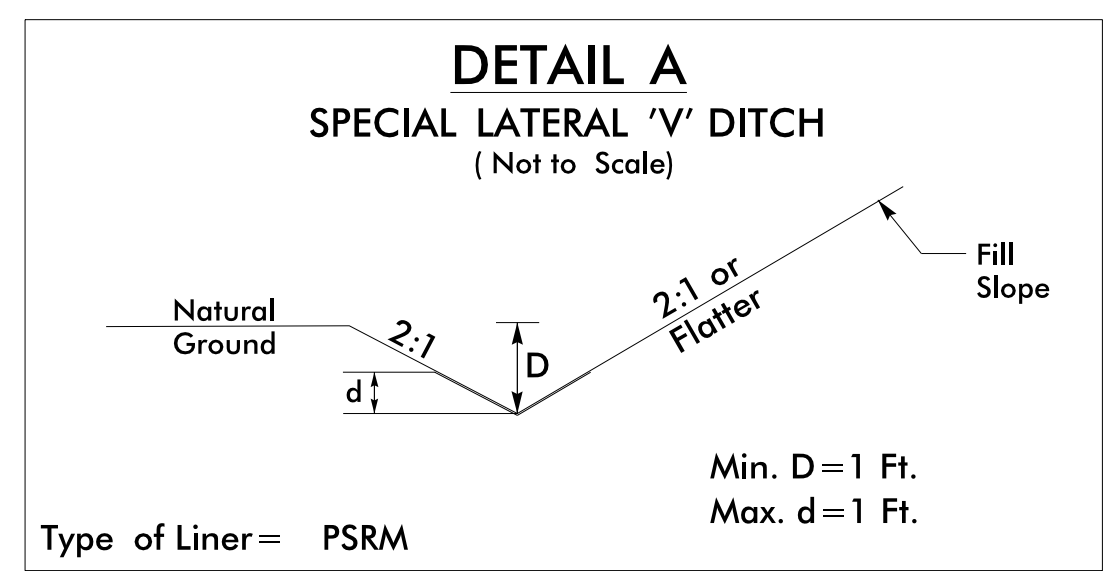

FROM STA. 13+00 LT TO STA. 14+48 LT
FROM STA. 16+51 LT TO STA. 17+50 LT

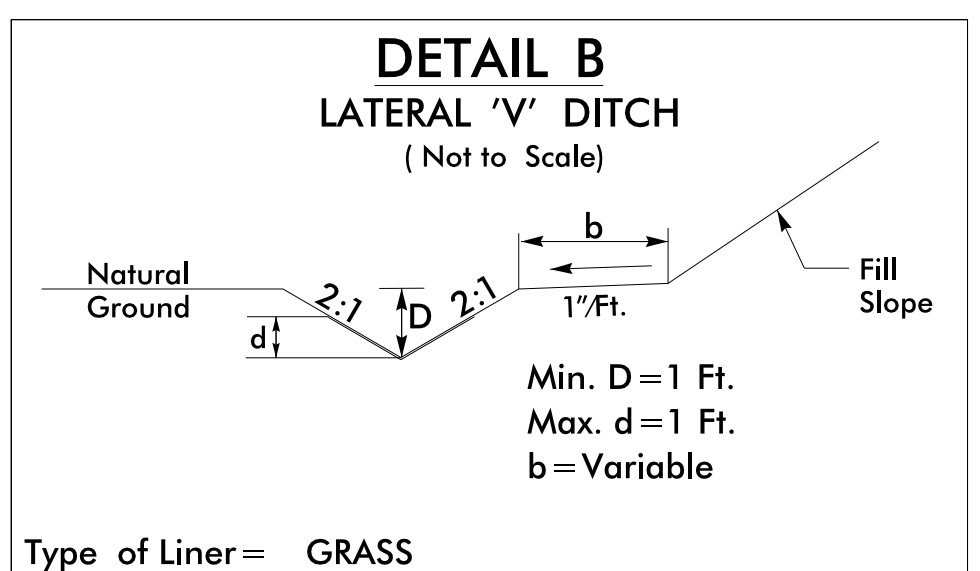

FROM STA. 14+55 RT TO STA. 15+20 RT

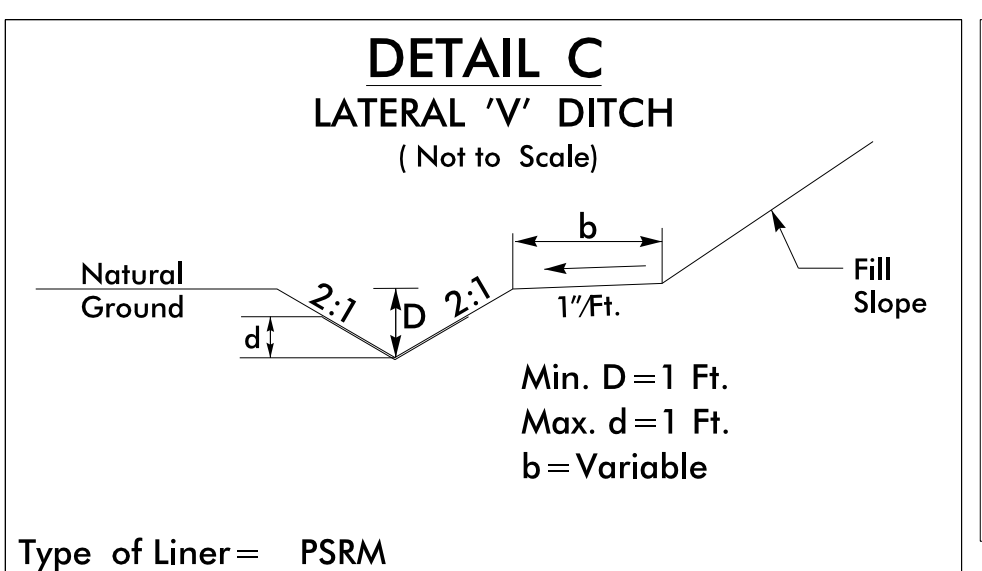

FROM STA. 14+48 LT TO STA. 15+25 LT
FROM STA. 15+57 LT TO STA. 16+51 LT

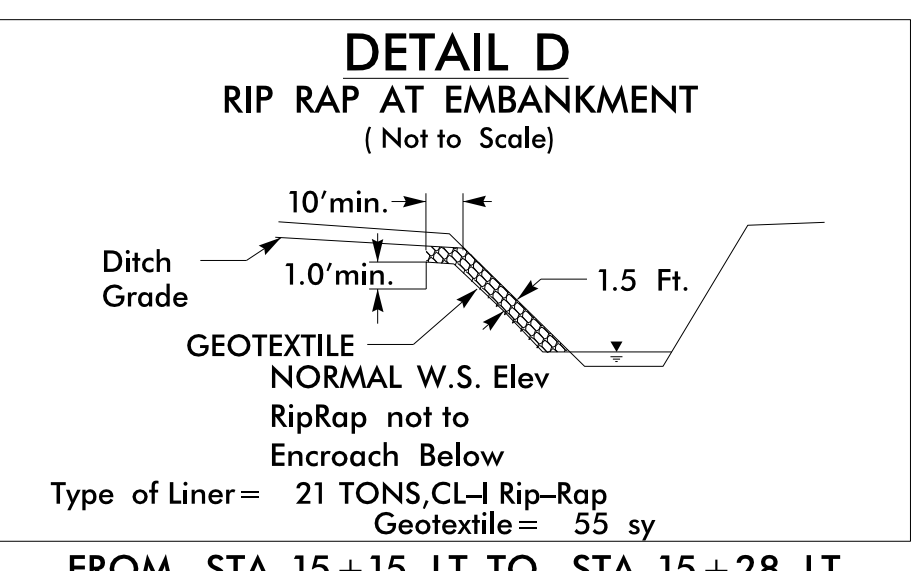

FROM STA. 15+15 LT TO STA. 15+28 LT
FROM STA. 15+54 LT TO STA. 15+67 LT
FROM STA. 15+10 RT TO STA. 15+35 RT
FROM STA. 15+62 RT TO STA. 15+69 RT

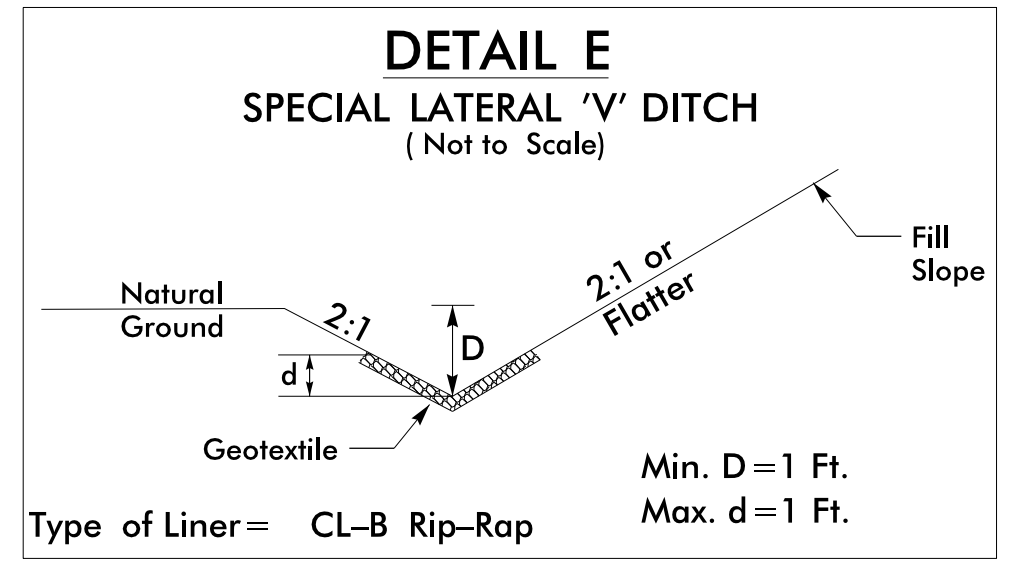
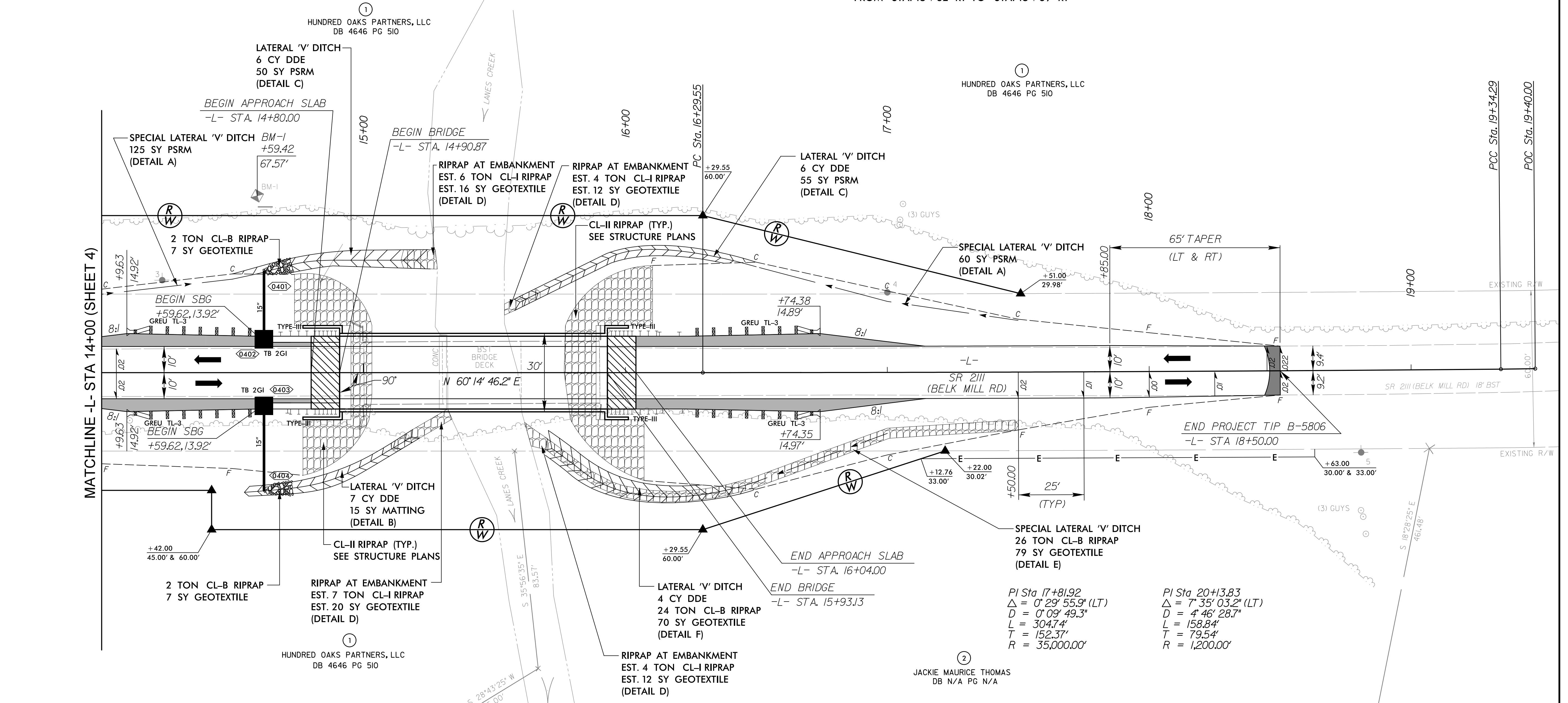

FROM STA. 16+50 RT TO STA. 17+50 RT

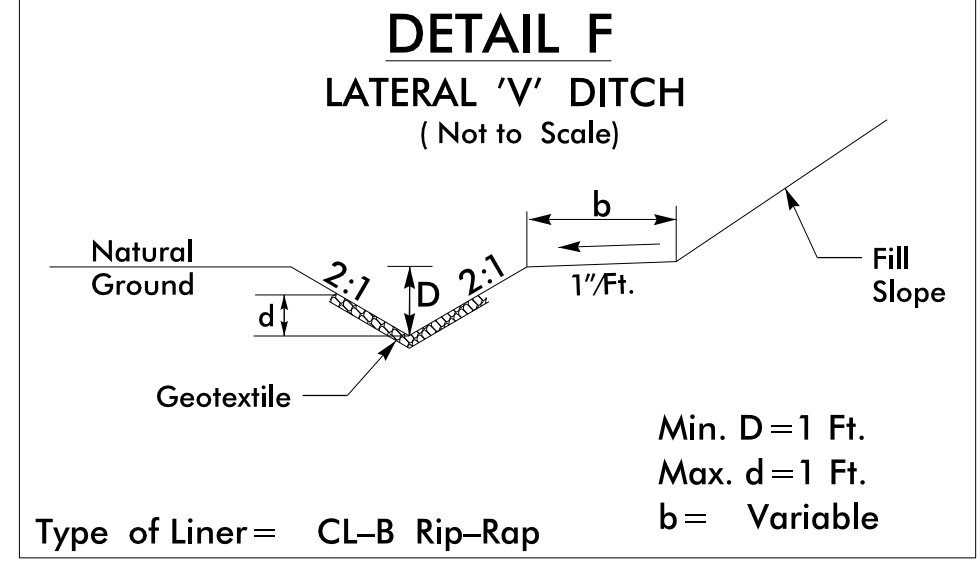

FROM STA. 15+69 RT TO STA. 16+50 RT

NOTE: INCIDENTAL MILL APPROXIMATELY 25' AT EACH TIE IN TO PROVIDE A SMOOTH TRANSITION TO THE EXISTING ASPHALT PAVEMENT.

SEE SHEET 7 FOR -L- PROFILE

7/12/2022 R:\2022\proj\sh\B-5806_r.dwg_rdy\psh05.dgn

8/17/99

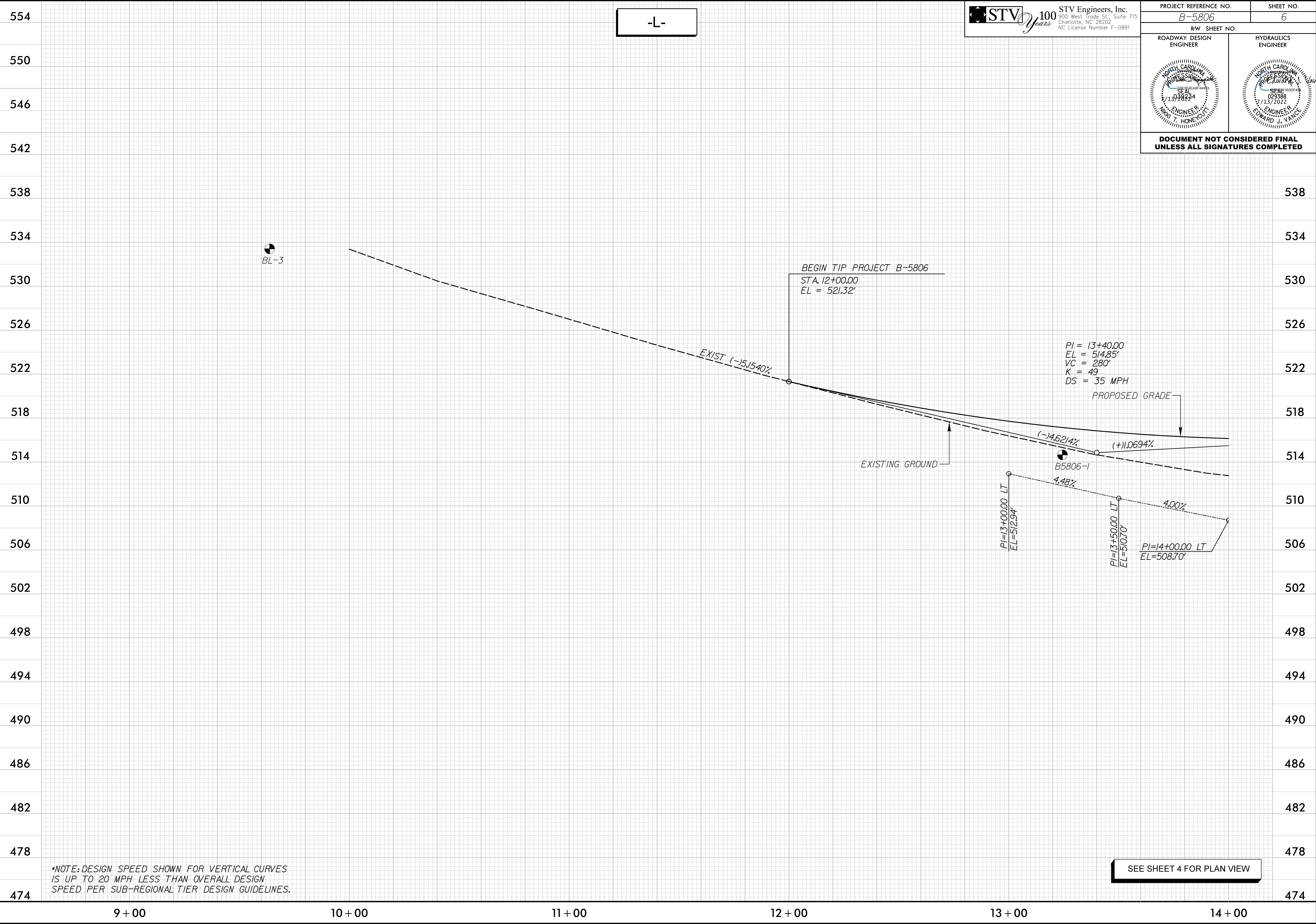

-L-

STV 100 Years
 STV Engineers, Inc.
 800 West Trade St., Suite 715
 Charlotte, NC 28202
 NC License Number F-0991

PROJECT REFERENCE NO. B-5806		SHEET NO. 6	
RW SHEET NO.		HYDRAULICS ENGINEER	
ROADWAY DESIGN ENGINEER		HYDRAULICS ENGINEER	
DOCUMENT NOT CONSIDERED FINAL UNLESS ALL SIGNATURES COMPLETED			

7/12/2022
 T:\12\2022
 r\12\2022\proj\proj\sh\B-5806_r.dwg_psh06.dgn

*NOTE: DESIGN SPEED SHOWN FOR VERTICAL CURVES IS UP TO 20 MPH LESS THAN OVERALL DESIGN SPEED PER SUB-REGIONAL TIER DESIGN GUIDELINES.

SEE SHEET 4 FOR PLAN VIEW

8/17/99

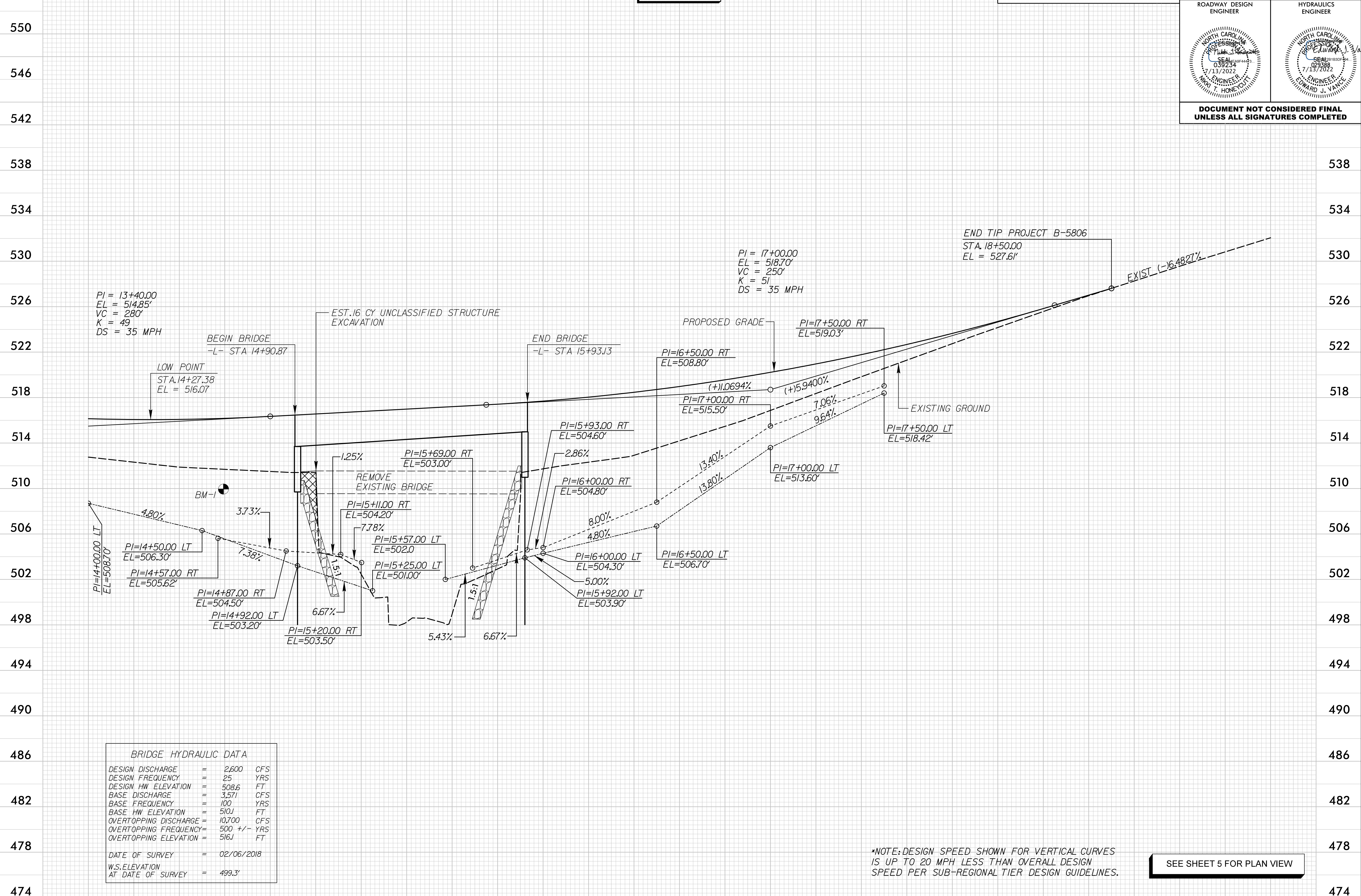

BRIDGE HYDRAULIC DATA	
DESIGN DISCHARGE	= 2,600 CFS
DESIGN FREQUENCY	= 25 YRS
DESIGN HW ELEVATION	= 508.6 FT
BASE DISCHARGE	= 3,571 CFS
BASE FREQUENCY	= 100 YRS
BASE HW ELEVATION	= 510.1 FT
OVERTOPPING DISCHARGE	= 10,700 CFS
OVERTOPPING FREQUENCY	= 500 +/- YRS
OVERTOPPING ELEVATION	= 516.1 FT
DATE OF SURVEY	= 02/06/2018
W.S. ELEVATION AT DATE OF SURVEY	= 499.3'

*NOTE: DESIGN SPEED SHOWN FOR VERTICAL CURVES IS UP TO 20 MPH LESS THAN OVERALL DESIGN SPEED PER SUB-REGIONAL TIER DESIGN GUIDELINES.

SEE SHEET 5 FOR PLAN VIEW

7/12/2022 R:\12\2022\proj\proj\sh\B-5806_rdu_psh07.dgn

OFF-SITE DETOUR SIGNING AND ROAD CLOSURE SIGNING

PROJECT REFERENCE NO. B-5806	SHEET NO. TMP-1
RW SHEET NO.	
 STV Engineers, Inc. 900 West Trade St., Suite 715 Charlotte, NC 28202 NC License Number F-0991	
DOCUMENT NOT CONSIDERED FINAL UNLESS ALL SIGNATURES COMPLETED	

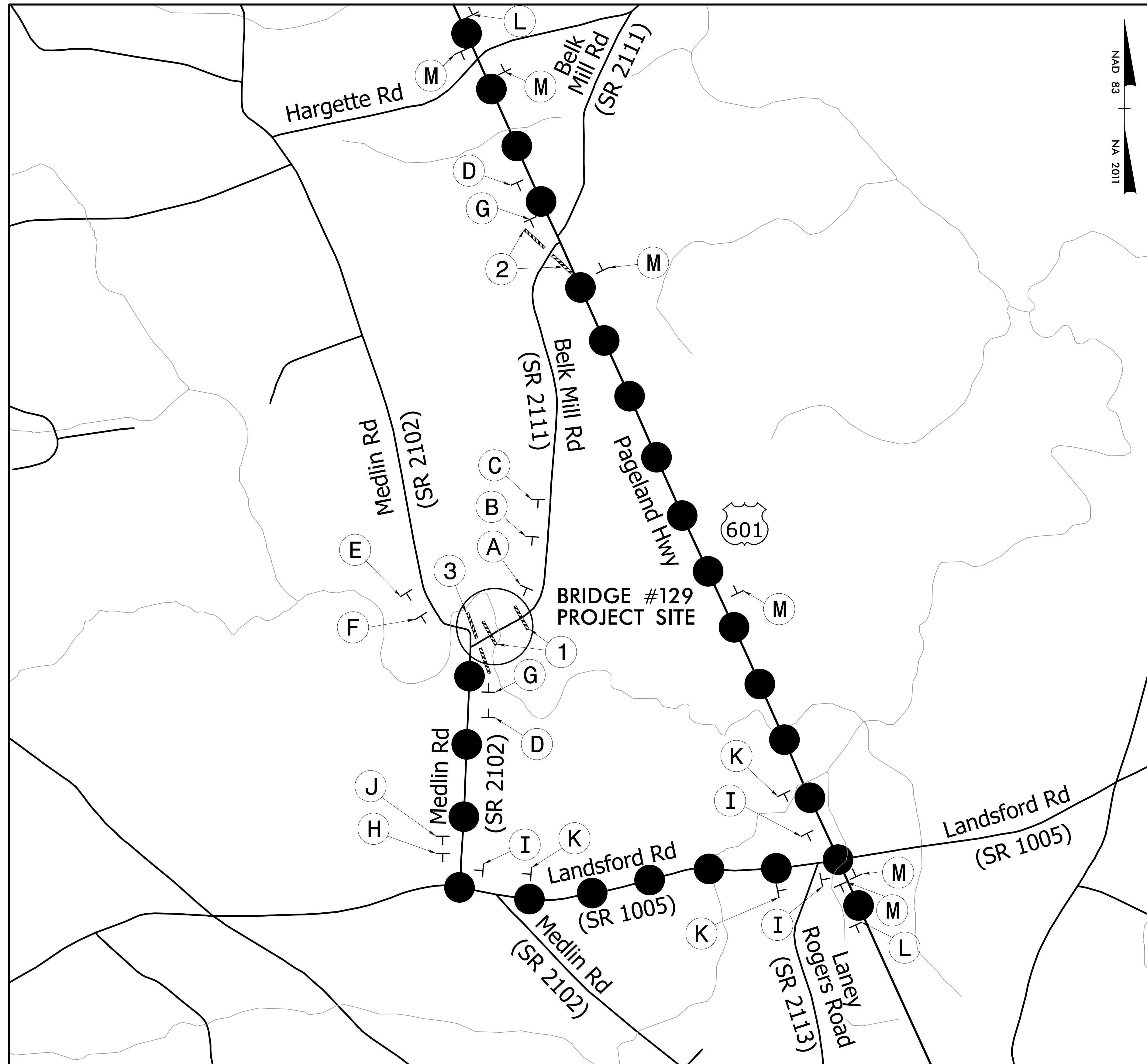
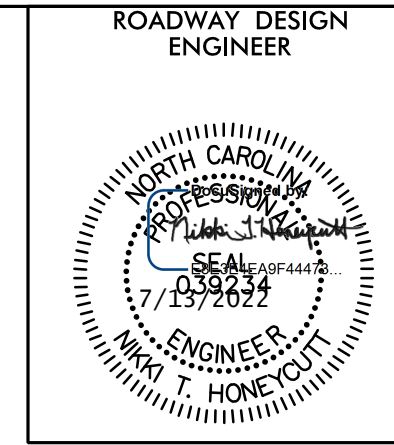

NAD 83
NA 2011

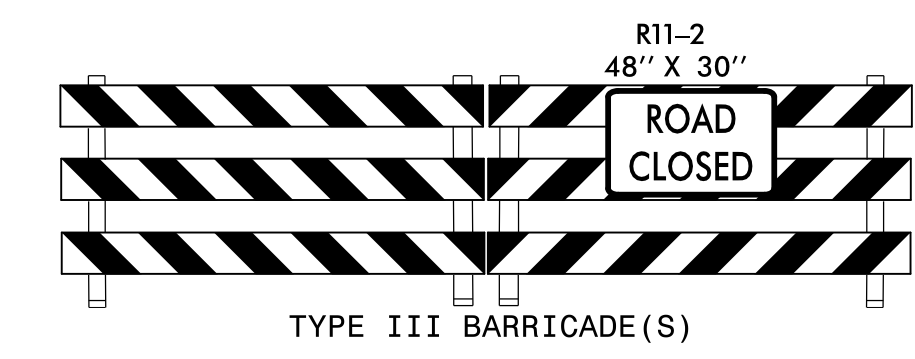

1

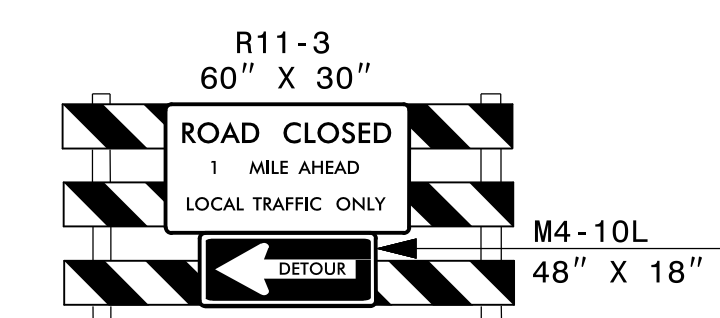

2

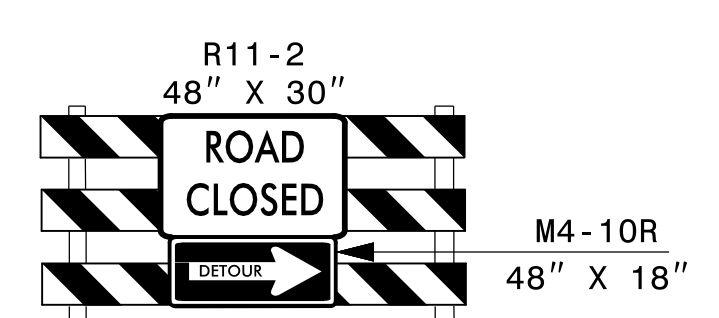

3

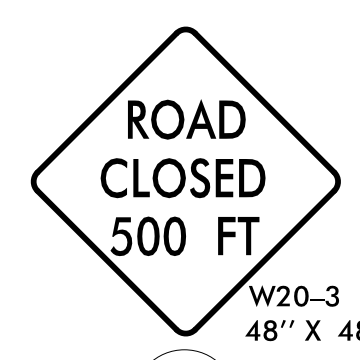

A

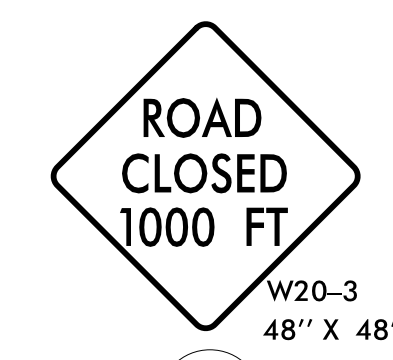

B

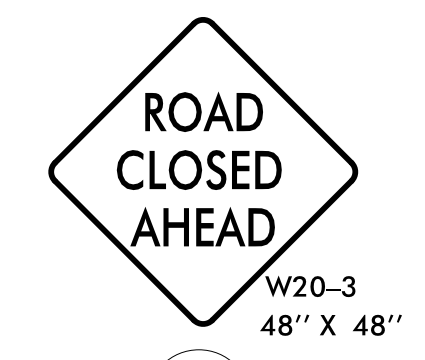

C

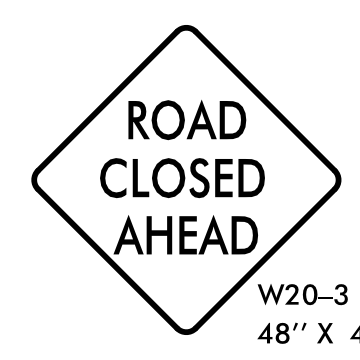

D

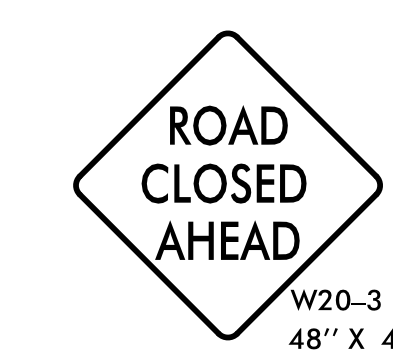

E



F

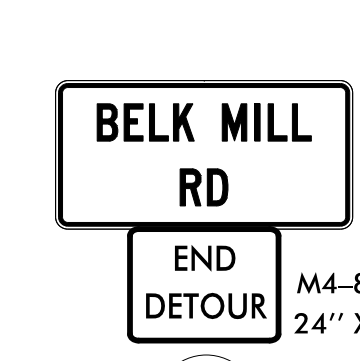

G

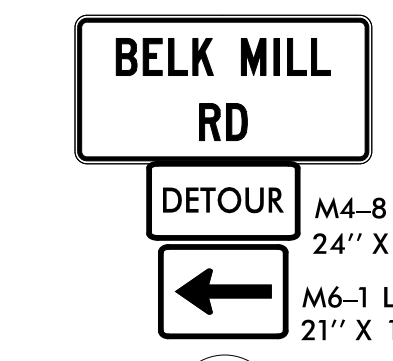

H

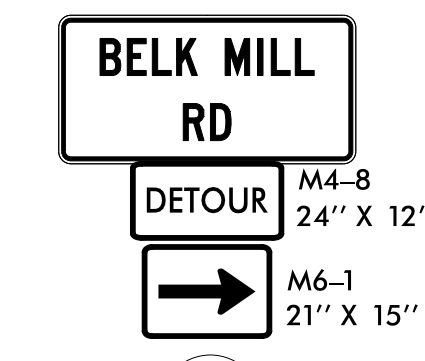

I

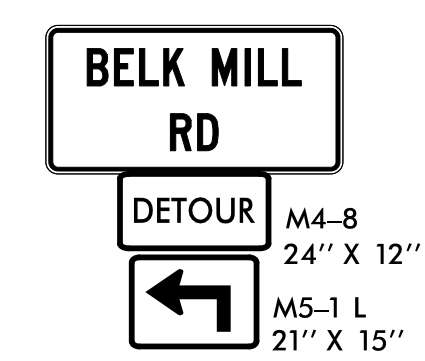

J

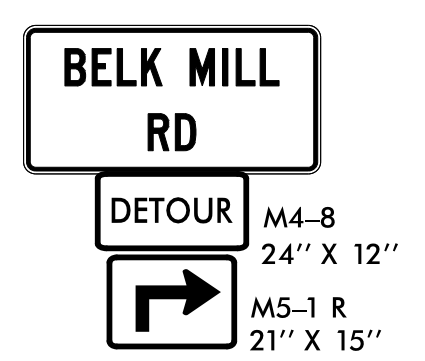

K

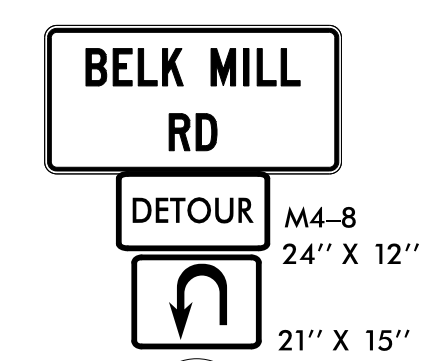

L

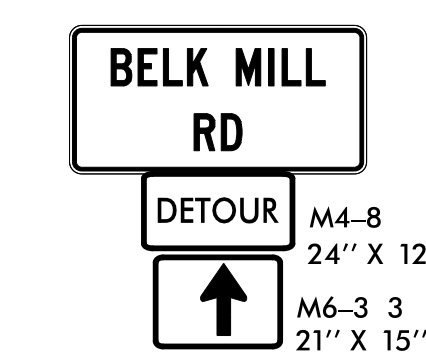

M

SEE ROADWAY STD DWG 1101.03, SHEET 1 OF 9 AND SHEET 2 OF 9 FOR ADVANCE WARNING AND BARRICADE PLACEMENT.

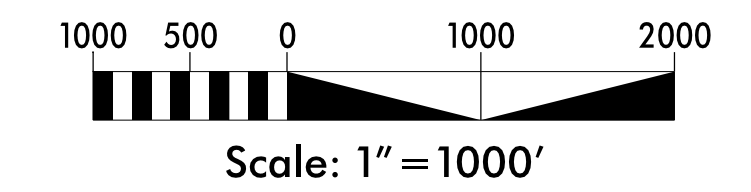

7/12/2022
F:\TrafficControl\CP\N\RJ52_RDY_TMP01.dgn
SourceSL

BRIDGE #890129

SIGN NUMBER: I-1 **BACKG COLOR:** Orange
TYPE: D **COPY COLOR:** Black
QUANTITY: See Plans
SIGN WIDTH: 48"
HEIGHT: 24"
TOTAL AREA: 8.0 Sq.Ft.
BORDER TYPE: FLUSH
RECESS: 0.47"
WIDTH: 0.63"
RADII: 1.5"
NO. Z BARS: **MAT'L:** 0.080" (2.0 mm) ALUMINUM
LENGTH:

SYMBOL	X	Y	WID	HT

DESIGN BY: JCT **CHECKED BY:** GHM
PROJECT ID: B-5806 **DIV:** 10 **DATE:** Oct 18, 2018

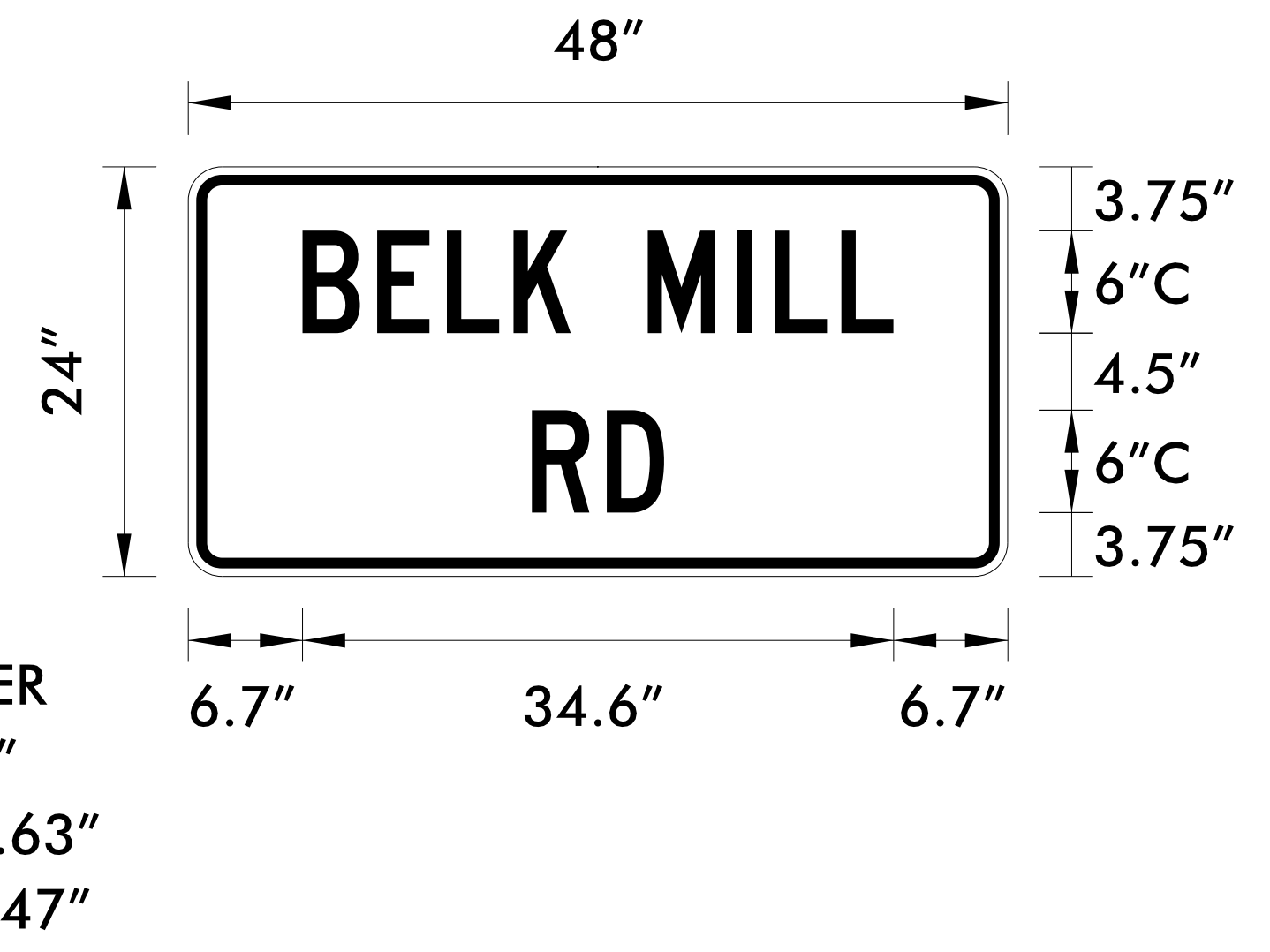

USE NOTES: 1,2
 1. Legend and border shall be direct applied encapsulated lens reflective sheeting.
 2. Background shall be NC Grade B fluorescent.

Spacing Factor is 1 unless specified otherwise

LETTER POSITIONS

Letter positions are to the lower left corners																				Series/Size
																				Text Length
B	E	L	K		M	I	L	L												C 2000 / 6
6.7	11.1	15.2	19.1	22.4	26.9	32.2	34.4	38.3												34.6
R	D																			C 2000 / 6
20.1	24.5																			7.7

NORTH CAROLINA D.O.T. SIGN DETAIL

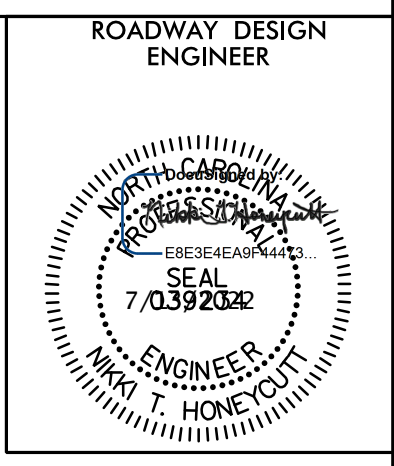

PAVEMENT MARKING PLAN

ROADWAY STANDARD DRAWINGS

THE FOLLOWING ROADWAY STANDARDS AS SHOWN IN "ROADWAY STANDARD DRAWINGS" - PROJECT SERVICES UNIT - N.C. DEPARTMENT OF TRANSPORTATION - RALEIGH, N.C., DATED JANUARY 2018 ARE APPLICABLE TO THIS PROJECT AND BY REFERENCE HEREBY ARE CONSIDERED A PART OF THESE PLANS:

STD. NO.	TITLE
1205.01	PAVEMENT MARKINGS - LINE TYPES AND OFFSETS
1205.02	PAVEMENT MARKINGS - TWO-LANE AND MULTILANE ROADWAYS
1205.12	PAVEMENT MARKINGS - BRIDGES
1261.01	GUARDRAIL AND BARRIER DELINEATORS - INSTALLATION SPACING
1261.02	GUARDRAIL AND BARRIER DELINEATORS - TYPES AND MOUNTING
1262.01	GUARDRAIL END DELINEATION

GENERAL NOTES

THE FOLLOWING GENERAL NOTES APPLY AT ALL TIMES FOR THE DURATION OF THE CONSTRUCTION PROJECT, EXCEPT WHEN OTHERWISE NOTED IN THE PLAN, OR DIRECTED BY THE ENGINEER.

A) INSTALL PAVEMENT MARKINGS ON THE FINAL SURFACE.

ROAD NAME	MARKING
SR 2111 (BELK MILL RD)	THERMO

- B) TIE PROPOSED PAVEMENT MARKING LINES TO EXISTING PAVEMENT MARKING LINES.
- C) REMOVE/REPLACE ANY CONFLICTING/DAMAGED PAVEMENT MARKINGS AND MARKERS.
- D) PASSING ZONES WILL BE DETERMINED IN THE FIELD AND MUST BE APPROVED BY THE ENGINEER.
- E) REPLACE ANY PAVEMENT MARKINGS BEYOND THE PROJECT LIMITS DAMAGED BY THE CONTRACTORS' OPERATIONS DURING CONSTRUCTION.

PAVEMENT MARKING SCHEDULE	
TA - THERMO	WHITE EDGELINE (4", 90MIL)
TI - THERMO	YELLOW DOUBLE CENTER LINE (4", 90MIL)

PROJECT REFERENCE NO. B-5806	SHEET NO. PMP-1
RW SHEET NO.	
 STV Engineers, Inc. 900 West Trade St., Suite 715 Charlotte, NC 28202 NC License Number F-0991	
DOCUMENT NOT CONSIDERED FINAL UNLESS ALL SIGNATURES COMPLETED	

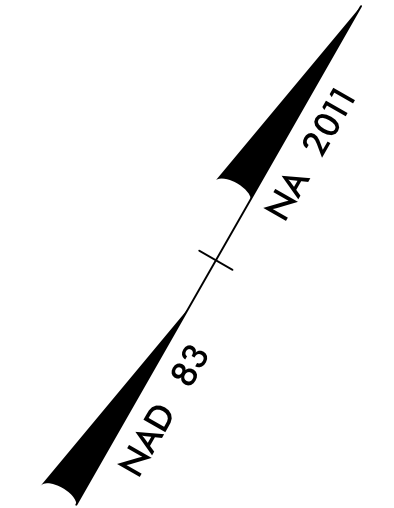
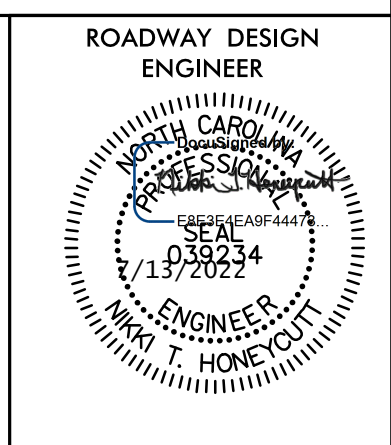

BEGIN (TA) (TI) MARKINGS
TIE TO EXISTING
-L- STA.12+00.00

BEGIN BRIDGE
-L- STA.14+90.87

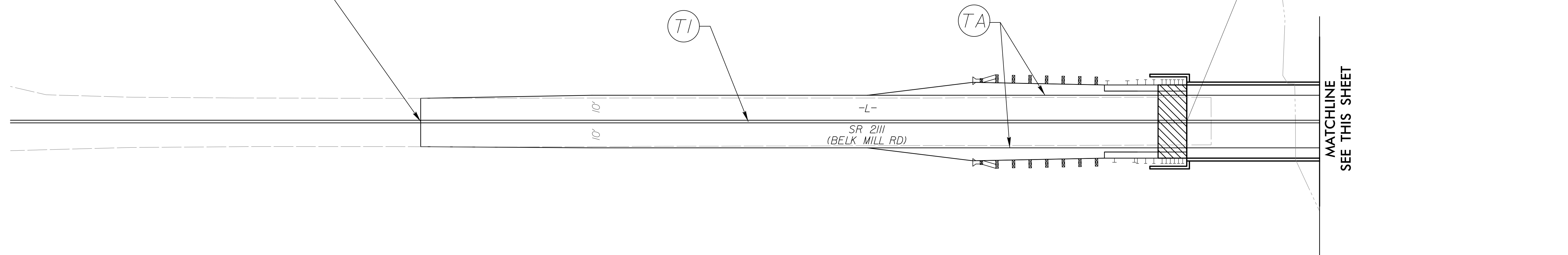

END BRIDGE
-L- STA.15+93.13

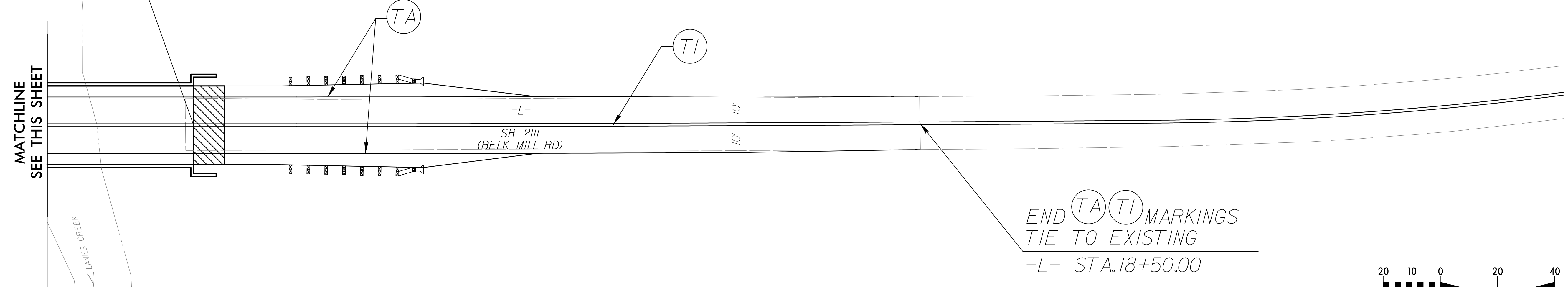

END (TA) (TI) MARKINGS
TIE TO EXISTING
-L- STA.18+50.00



Scale: 1" = 20'

TIP PROJECT: B-5806

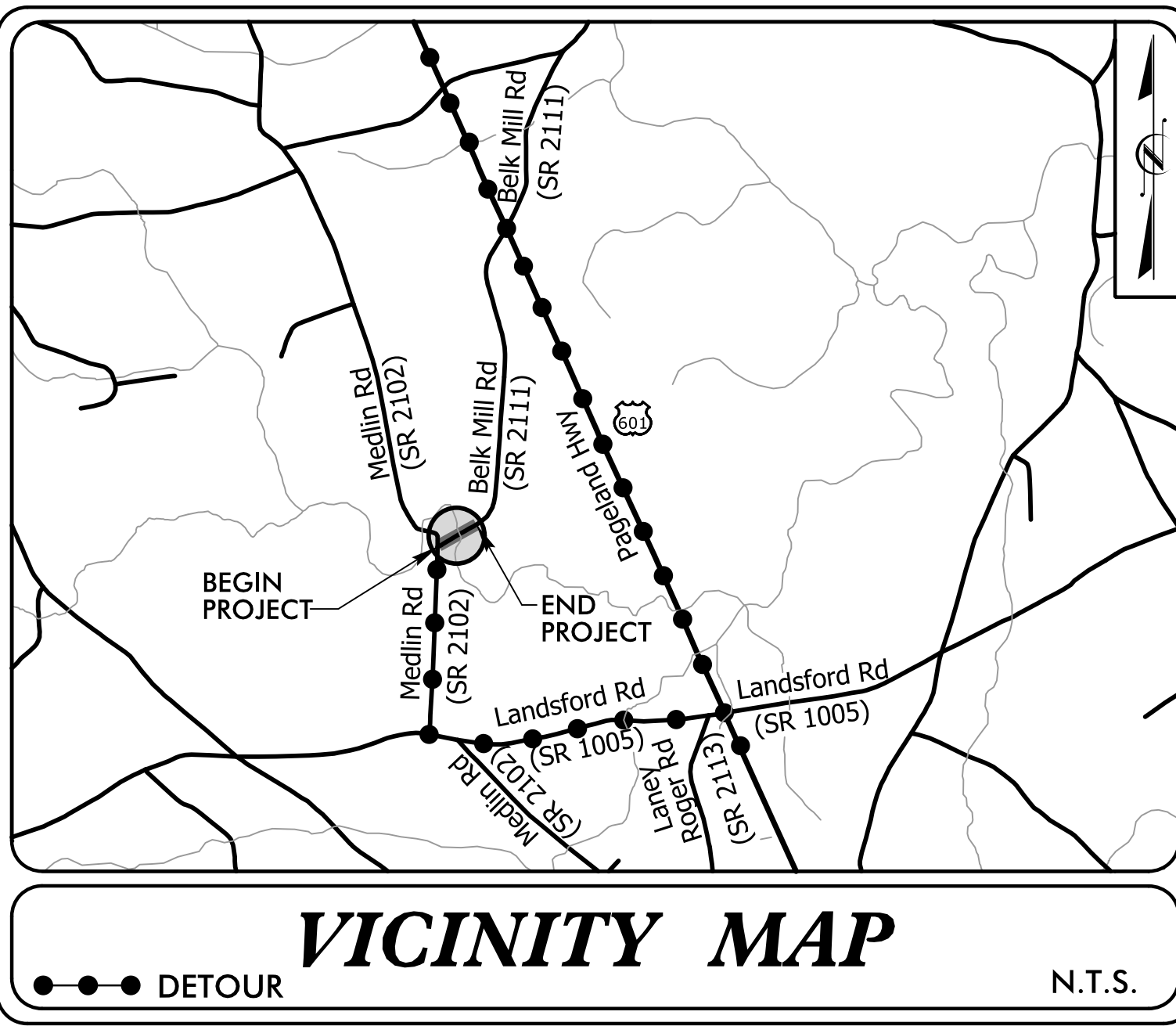

STATE OF NORTH CAROLINA
DIVISION OF HIGHWAYS
**PLAN FOR PROPOSED
HIGHWAY EROSION CONTROL**

STATE	STATE PROJECT REFERENCE NO.	SHEET NO.	TOTAL SHEETS
N.C.	B-5806	EC-1	9
STATE PROJ. NO.	F.A. PROJ. NO.	DESCRIPTION	
45760.1.1		P.E.	
45760.2.1		ROW & UTIL	
45760.3.1		CONST.	

EROSION AND SEDIMENT CONTROL MEASURES

Sed. #	Description	Symbol
1630.05	Temporary Silt Ditch	TD
1630.05	Temporary Diversion	TD
1605.01	Temporary Silt Fence	III III III
1606.01	Special Sediment Control Fence	III III III
1622.01	Temporary Berms and Slope Drains	TD
1630.02	Silt Basin Type B	SB
1633.01	Temporary Rock Silt Check Type-A	RS
	Temporary Rock Silt Check Type-A with Matting and Polyacrylamide (PAM)	RS
1633.02	Temporary Rock Silt Check Type-B	RS
	Wattle / Coir Fiber Wattle	W
	Wattle / Coir Fiber Wattle with Polyacrylamide (PAM)	W
1634.01	Temporary Rock Sediment Dam Type-A	RD
1634.02	Temporary Rock Sediment Dam Type-B	RD
1635.01	Rock Pipe Inlet Sediment Trap Type-A	RPI
1635.02	Rock Pipe Inlet Sediment Trap Type-B	RPI
1630.04	Stilling Basin	SB
1630.06	Special Stilling Basin	SB
	Rock Inlet Sediment Trap:	
1632.01	Type A	A
1632.02	Type B	B
1632.03	Type C	C
	Skimmer Basin	SB
	Tiered Skimmer Basin	SB
	Infiltration Basin	SB

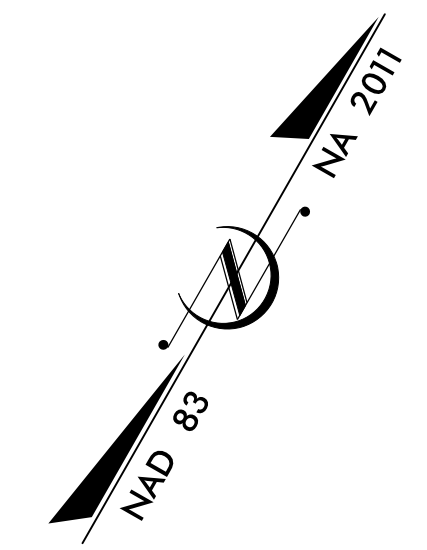

BEGIN TIP PROJECT B-5806
-L- STA. 12+00.00

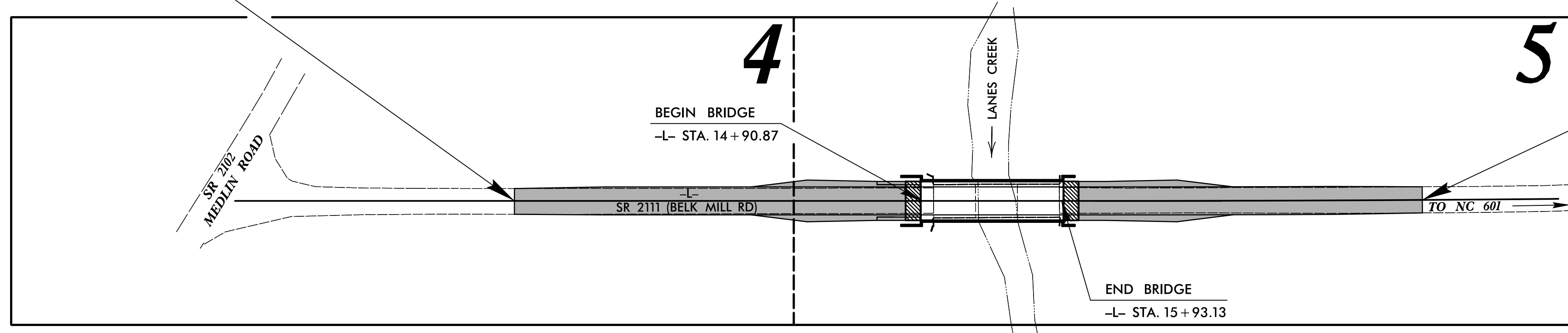

END TIP PROJECT B-5806
-L- STA. 18+50.00

**THIS PROJECT CONTAINS
EROSION CONTROL PLANS
FOR CLEARING AND
GRUBBING PHASE OF
CONSTRUCTION.**

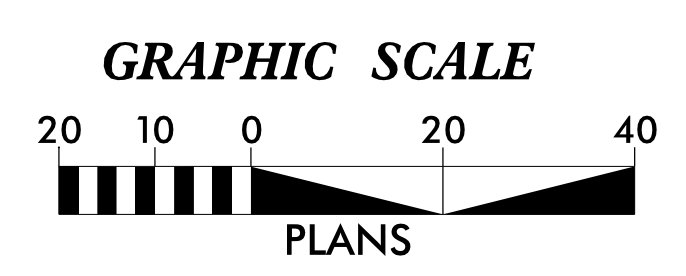

**THESE EROSION AND SEDIMENT CONTROL PLANS COMPLY WITH
THE APPLICABLE REGULATIONS SET FORTH BY THE NCG-010000
GENERAL CONSTRUCTION PERMIT EFFECTIVE APRIL 1, 2019
AND ISSUED BY THE NORTH CAROLINA DEPARTMENT OF
ENVIRONMENTAL QUALITY DIVISION OF WATER RESOURCES.**



Prepared In the Office of:
STV ENGINEERS, INC.
900 WEST TRADE STREET, SUITE 715
CHARLOTTE, NC 28202
NC LICENSE NUMBER F-0991

Designed by:
EDWARD VANCE, PE **029388**
NAME LEVEL III CERTIFICATION NO.

Roadway Standard Drawings

The following roadway english standards as appear in "Roadway Standard Drawings"- Roadway Design Unit - N. C. Department of Transportation - Raleigh, N. C., dated January 2018 and the latest revision thereto are applicable to this project and by reference hereby are considered a part of these plans.

1604.01 Railroad Erosion Control Detail	1632.01 Rock Inlet Sediment Trap Type A
1605.01 Temporary Silt Fence	1632.02 Rock Inlet Sediment Trap Type B
1606.01 Special Sediment Control Fence	1632.03 Rock Inlet Sediment Trap Type C
1607.01 Gravel Construction Entrance	1633.01 Temporary Rock Silt Check Type A
1622.01 Temporary Berms and Slope Drains	1633.02 Temporary Rock Silt Check Type B
1630.01 Riser Basin	1634.01 Temporary Rock Sediment Dam Type A
1630.02 Silt Basin Type B	1634.02 Temporary Rock Sediment Dam Type B
1630.03 Temporary Silt Ditch	1635.01 Rock Pipe Inlet Sediment Trap Type A
1630.04 Stilling Basin	1635.02 Rock Pipe Inlet Sediment Trap Type B
1630.05 Temporary Diversion	1640.01 Coir Fiber Baffle
1630.06 Special Stilling Basin	1645.01 Temporary Stream Crossing
1631.01 Matting Installation	

COIR FIBER WATTLE WITH POLYACRYLAMIDE (PAM) DETAIL

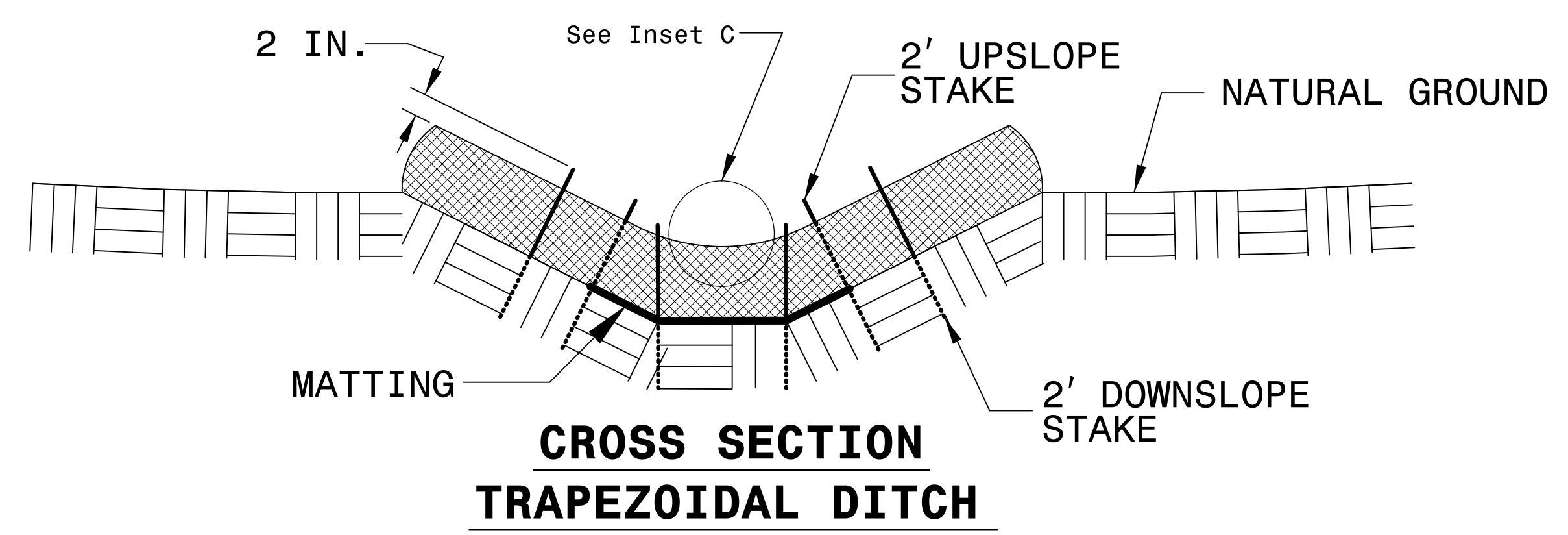
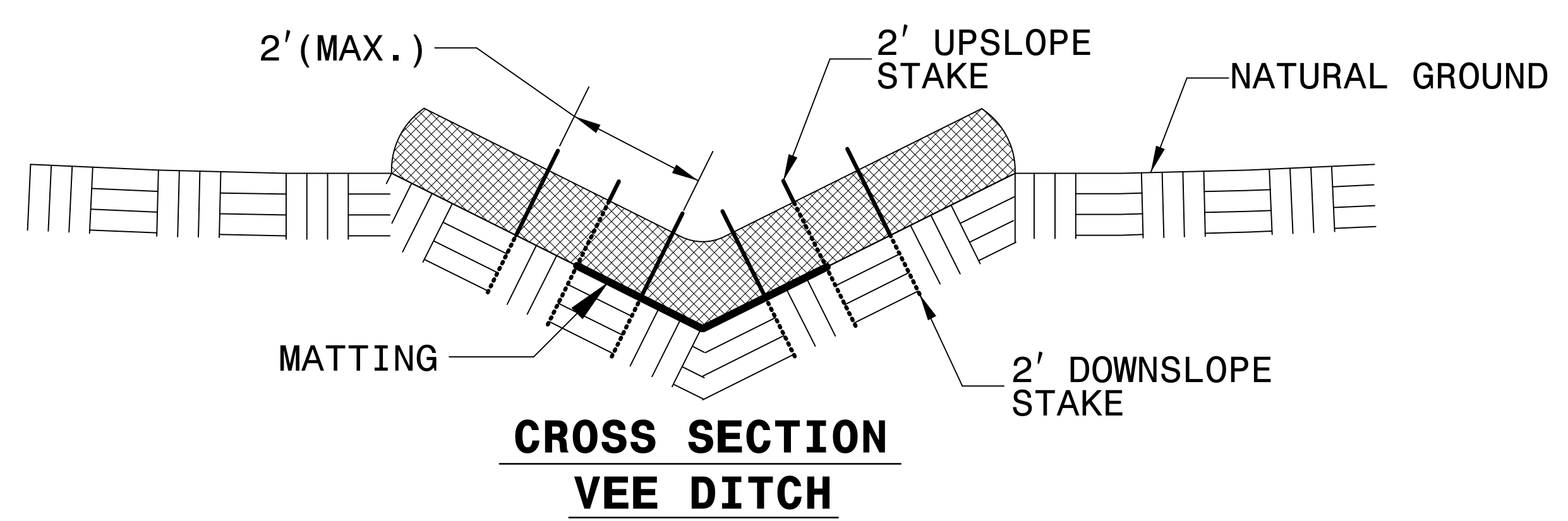
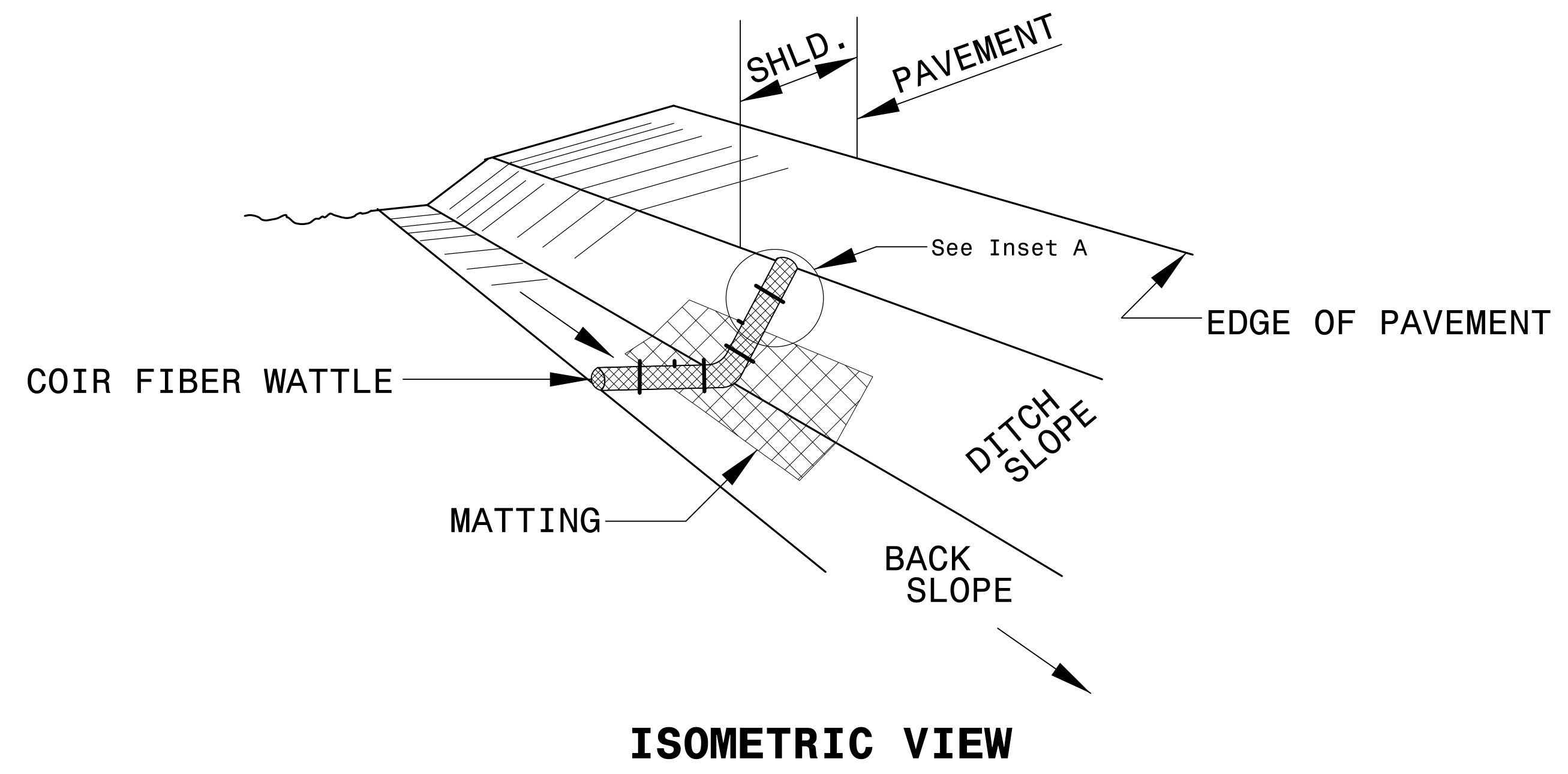

- NOTES:
- USE MINIMUM 12 IN. DIAMETER COIR FIBER (COCONUT FIBER) WATTLE.
 - USE 2 FT. WOODEN STAKES WITH A 2 IN. BY 2 IN. NOMINAL CROSS SECTION.
 - ONLY INSTALL WATTLE(S) TO A HEIGHT IN DITCH SO FLOW WILL NOT WASH AROUND WATTLE AND SCOUR DITCH SLOPES AND AS DIRECTED.
 - INSTALL A MINIMUM OF 2 UPSLOPE STAKES AND 4 DOWNSLOPE STAKES AT AN ANGLE TO WEDGE WATTLE TO BOTTOM OF DITCH.
 - PROVIDE STAPLES MADE OF 0.125 IN. DIAMETER STEEL WIRE FORMED INTO A U SHAPE NOT LESS THAN 12" IN LENGTH.
 - INSTALL STAPLES APPROXIMATELY EVERY 1 LINEAR FOOT ON BOTH SIDES OF WATTLE AND AT EACH END TO SECURE IT TO THE SOIL.
 - INSTALL MATTING IN ACCORDANCE WITH SECTION 1631 OF THE STANDARD SPECIFICATIONS.
 - PRIOR TO POLYACRYLAMIDE (PAM) APPLICATION, OBTAIN A SOIL SAMPLE FROM PROJECT LOCATION, AND FROM OFFSITE MATERIAL, AND ANALYZE FOR APPROPRIATE PAM FLOCCULANT TO BE APPLIED TO EACH WATTLE.
 - INITIALLY APPLY 2 OUNCES OF ANIONIC OR NEUTRALLY CHARGED PAM OVER WATTLE WHERE WATER WILL FLOW AND 1 OUNCE OF PAM ON MATTING ON EACH SIDE OF WATTLE. REAPPLY PAM AFTER EVERY RAINFALL EVENT THAT IS EQUAL TO OR EXCEEDS 0.50 IN.

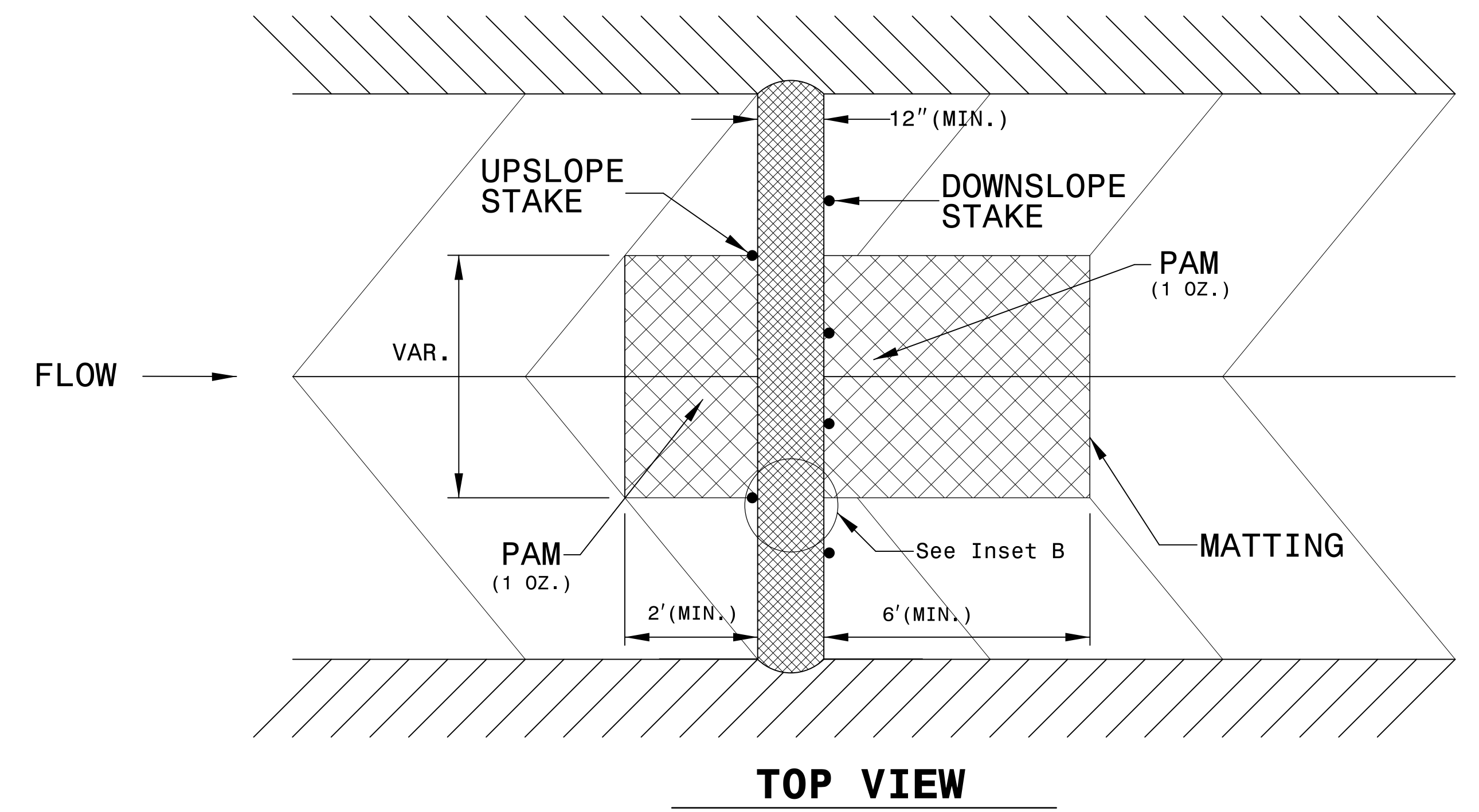
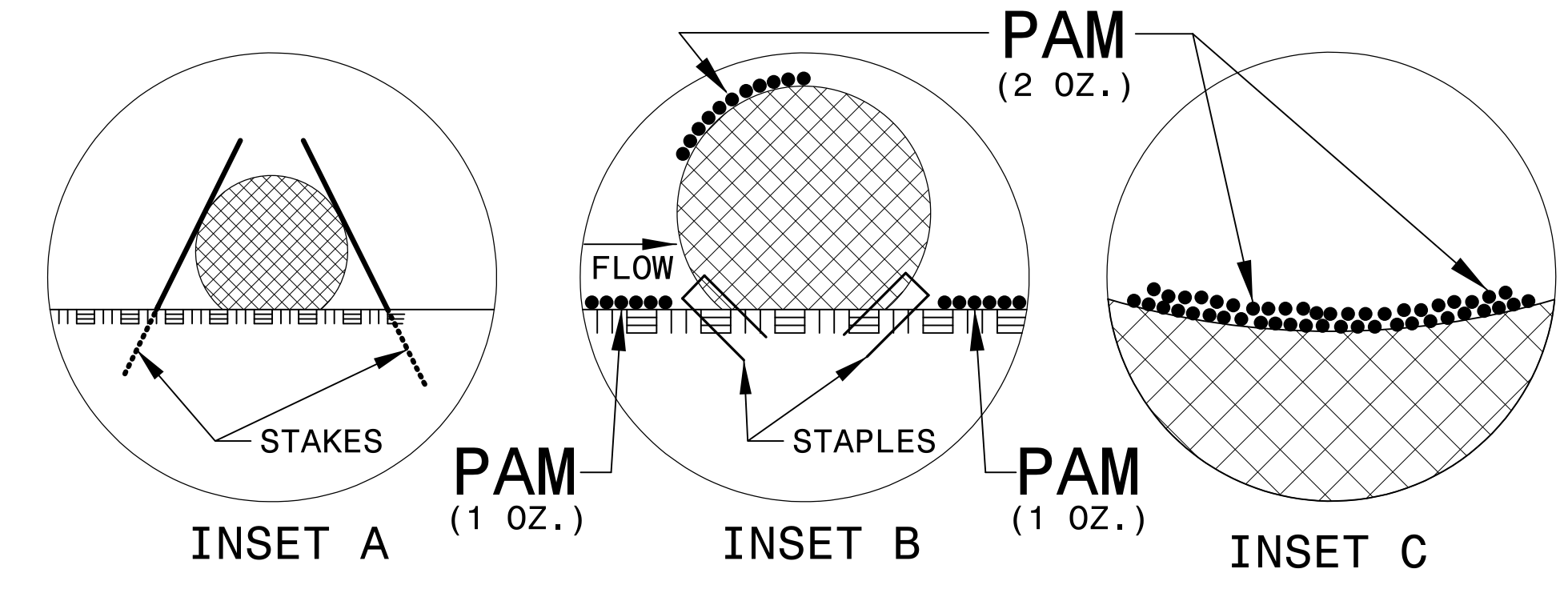

8/17/99
 7/12/2022 Environmental\Design\EC_Sheets\B-5806-EC_psh02.dgn
 R:\E\2022 Environmental\Design\EC_Sheets\B-5806-EC_psh02.dgn
 Sources

SILT FENCE COIR FIBER WATTLE BREAK DETAIL

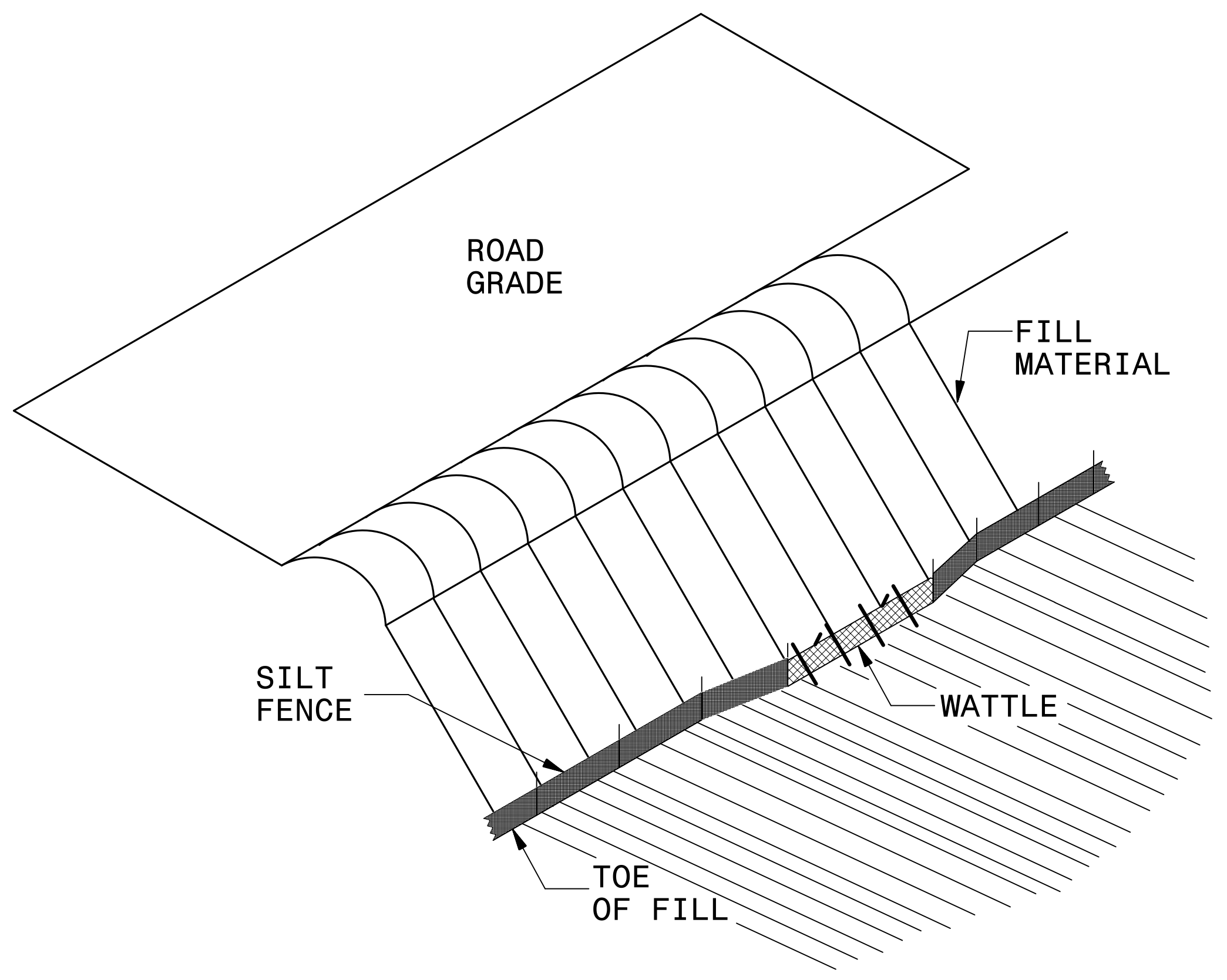

ISOMETRIC VIEW

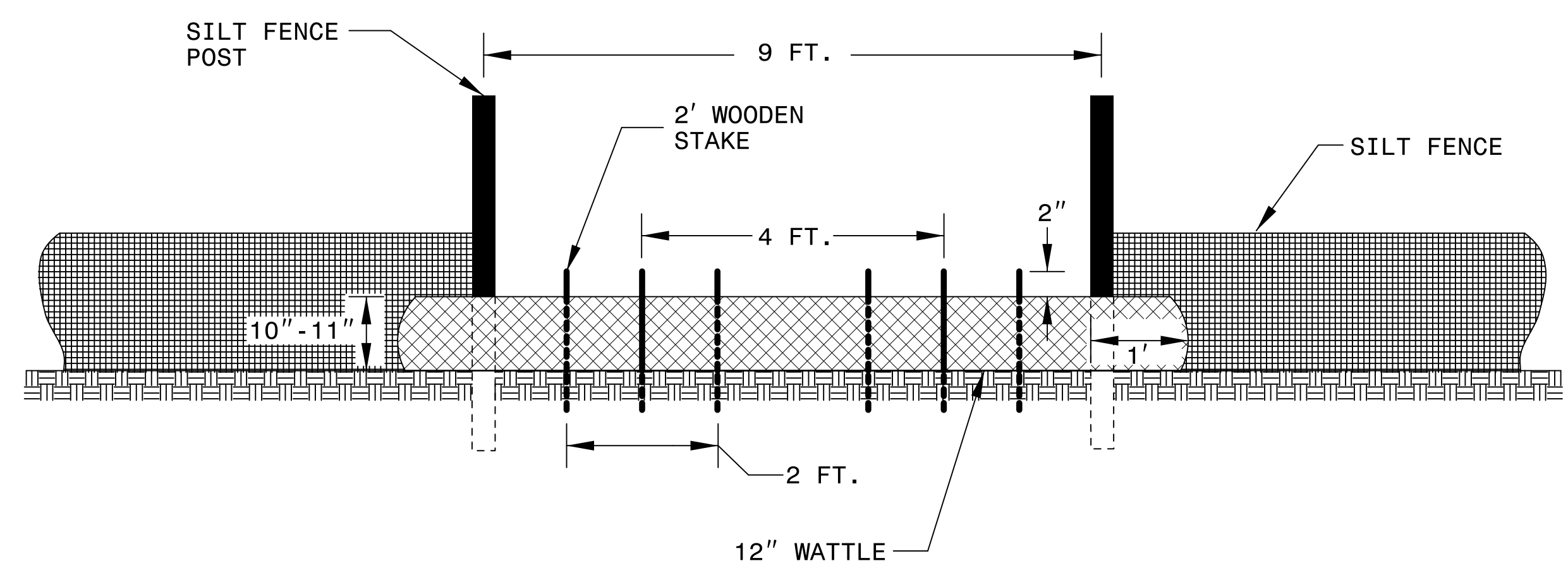

VIEW FROM SLOPE

NOTES:

- USE MINIMUM 12 IN. DIAMETER COIR FIBER (COCONUT FIBER) WATTLE AND LENGTH OF 10 FT.
- EXCAVATE A 1 TO 2 INCH TRENCH FOR WATTLE TO BE PLACED.
- DO NOT PLACE WATTLE ON TOE OF SLOPE.
- USE 2 FT. WOODEN STAKES WITH A 2 IN. BY 2 IN. NOMINAL CROSS SECTION.
- INSTALL A MINIMUM OF 2 UPSLOPE STAKES AND 4 DOWNSLOPE STAKES AT AN ANGLE TO WEDGE WATTLE TO GROUND.
- PROVIDE STAPLES MADE OF 0.125 IN. DIAMETER STEEL WIRE FORMED INTO A U SHAPE NOT LESS THAN 12" IN LENGTH.
- INSTALL STAPLES APPROXIMATELY EVERY 1 LINEAR FOOT ON BOTH SIDES OF WATTLE AND AT EACH END TO SECURE IT TO THE SOIL.
- WATTLE INSTALLATION CAN BE ON OUTSIDE OF THE SILT FENCE AS DIRECTED.
- INSTALL TEMPORARY SILT FENCE IN ACCORDANCE WITH SECTION 1605 OF THE STANDARD SPECIFICATIONS.

INSET A

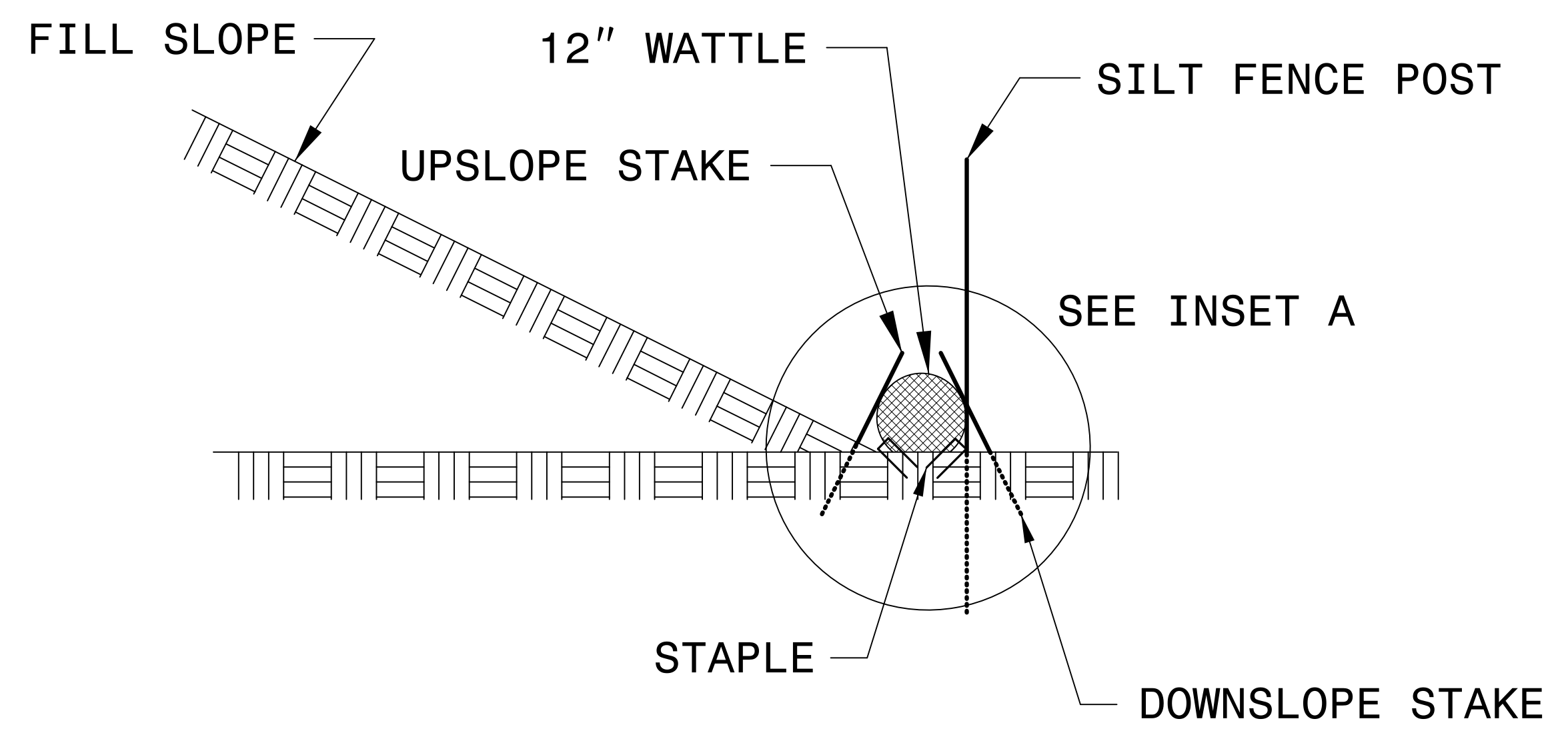
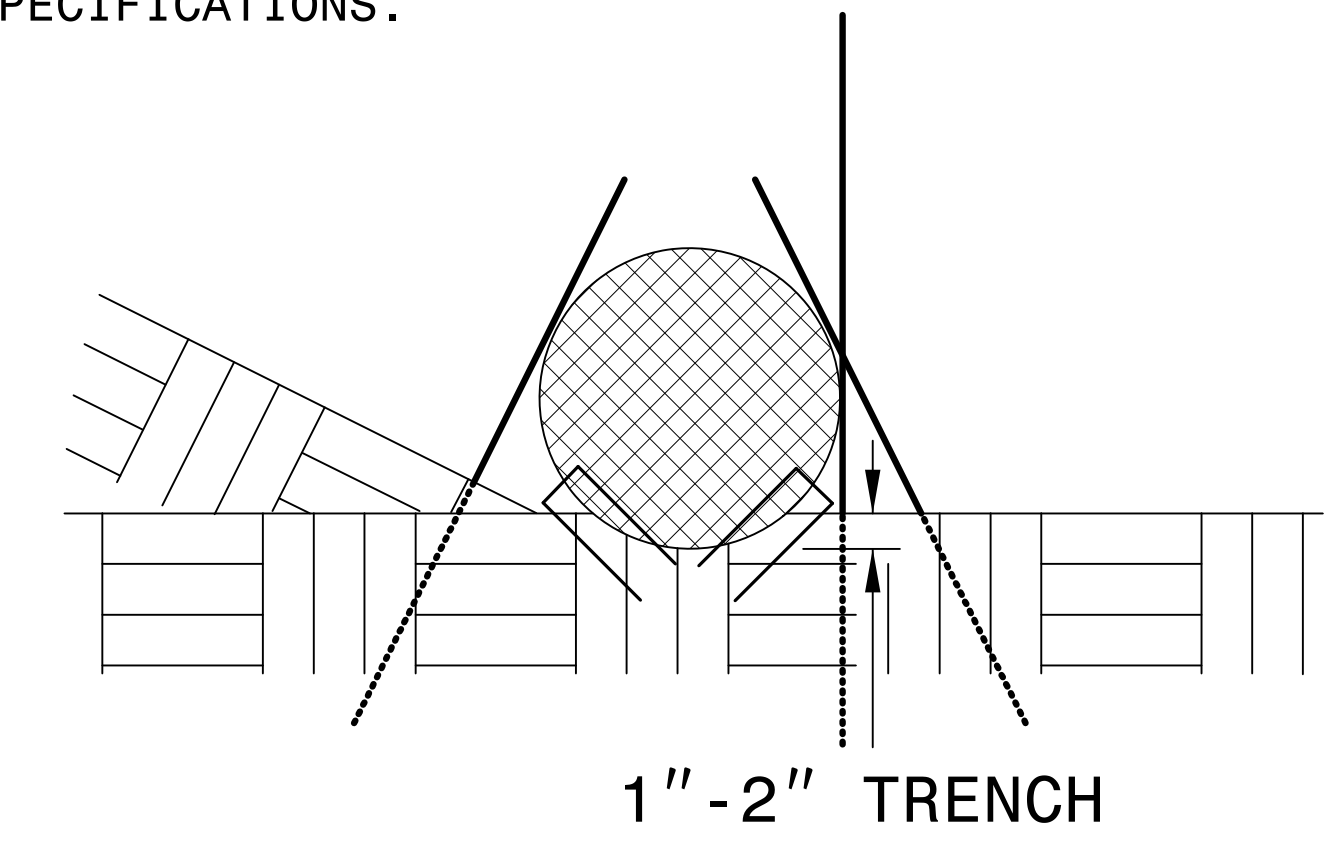

SIDE VIEW

8/17/99
7/12/2022
C:\Users\j\Documents\Design\EC_Sheets\B-5806\EC_psh\02A.dgn

DIVISION OF HIGHWAYS
STATE OF NORTH CAROLINA

SOIL STABILIZATION TIMEFRAMES

<i>SITE DESCRIPTION</i>	<i>STABILIZATION TIME</i>	<i>TIMEFRAME EXCEPTIONS</i>
PERIMETER DIKES, SWALES, DITCHES AND SLOPES	7 DAYS	NONE
HIGH QUALITY WATER (HQW) ZONES	7 DAYS	NONE
SLOPES STEEPER THAN 3:1	7 DAYS	IF SLOPES ARE 10' OR LESS IN LENGTH AND ARE NOT STEEPER THAN 2:1, 14 DAYS ARE ALLOWED.
SLOPES 3:1 OR FLATTER	14 DAYS	7 DAYS FOR SLOPES GREATER THAN 50' IN LENGTH.
ALL OTHER AREAS WITH SLOPES FLATTER THAN 4:1	14 DAYS	NONE, EXCEPT FOR PERIMETERS AND HQW ZONES.

CLEARING AND GRUBBING
EROSION CONTROL SHEET FOR
CONSTRUCTION SHEET 4

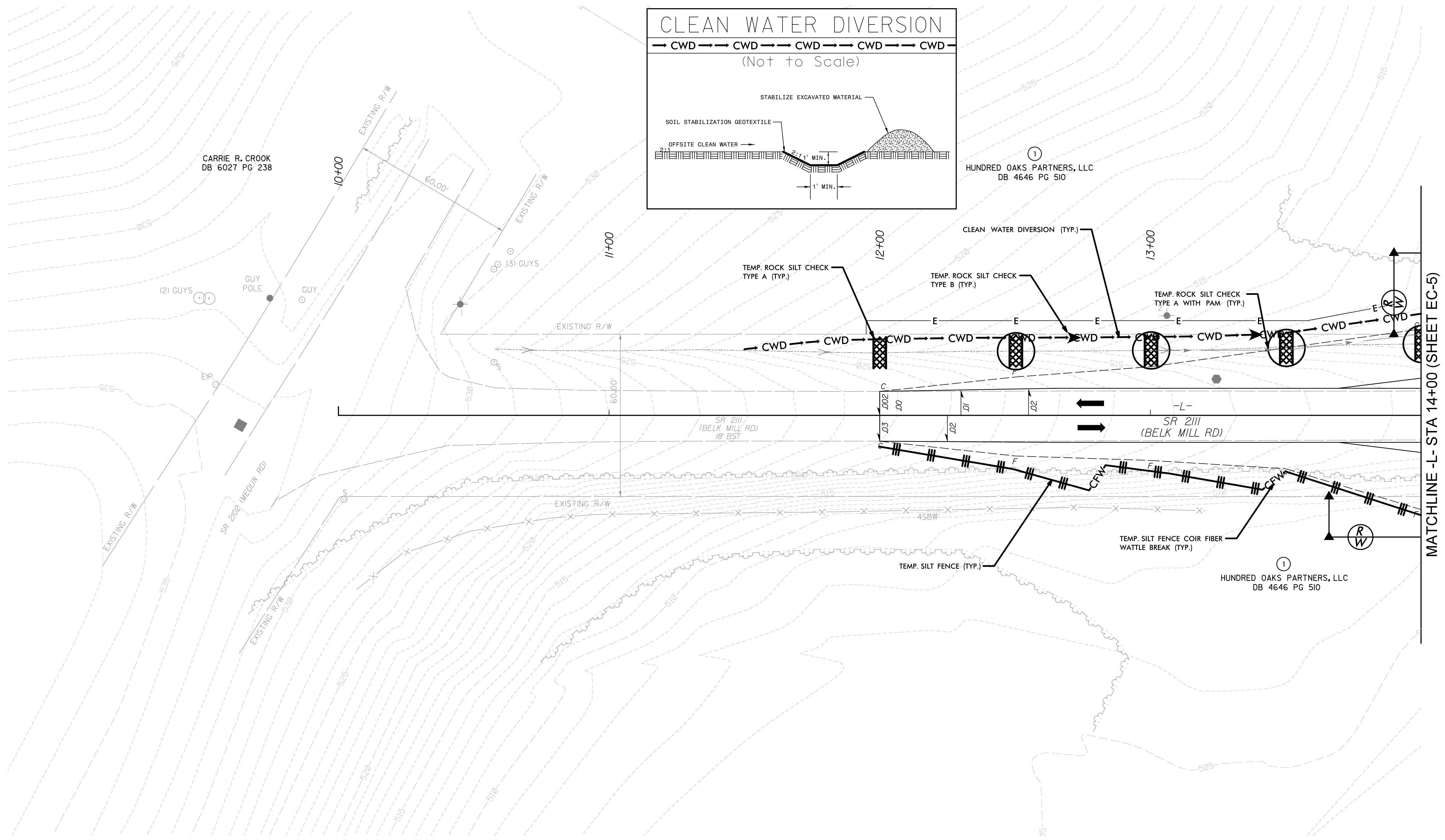
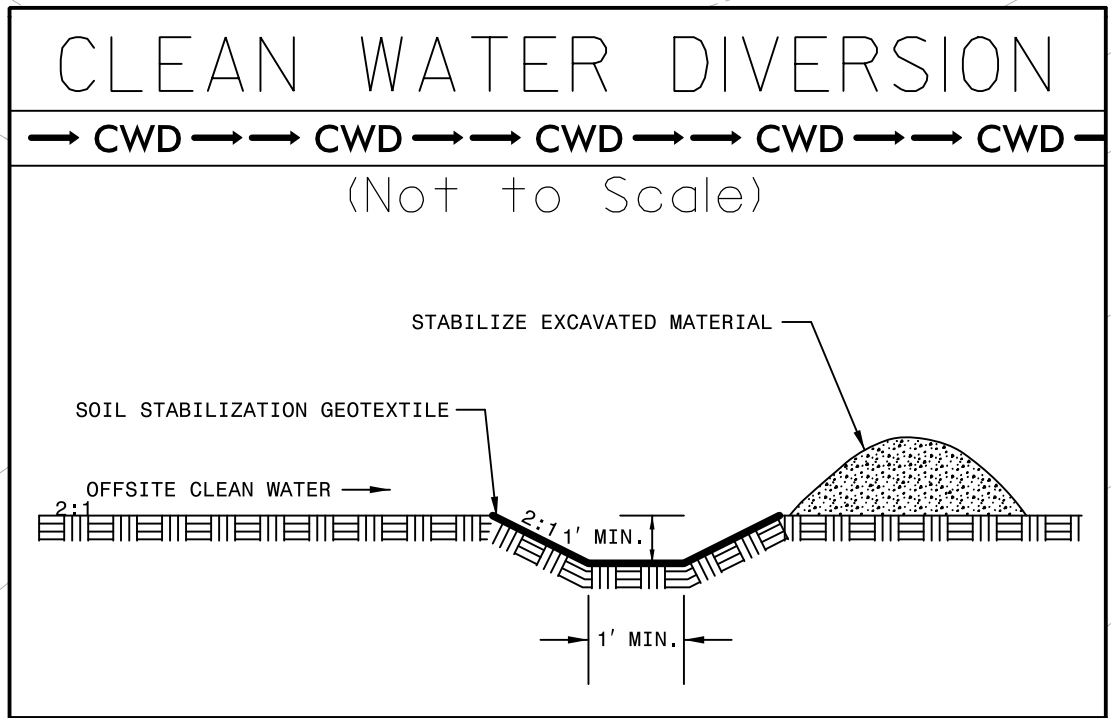
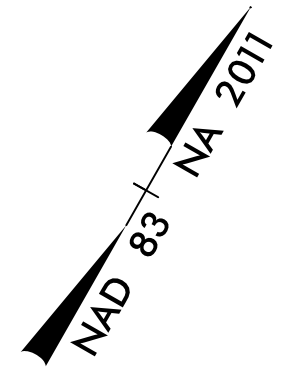
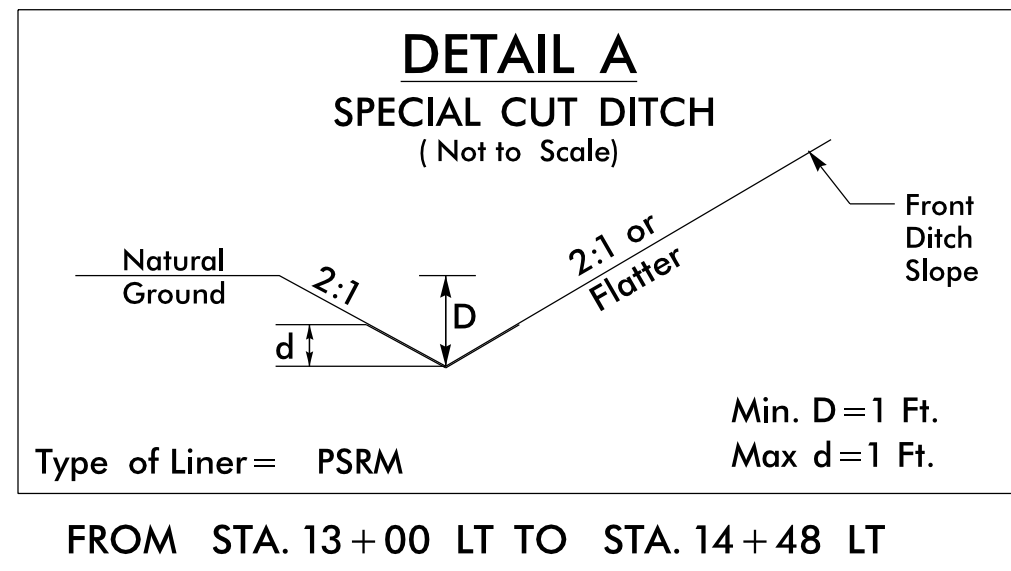

MATCHLINE -L- STA 14+00 (SHEET EC-5)

NOTE:
PLACE TEMPORARY ROCK SEDIMENT DAMS TYPE - B AND TEMPORARY ROCK SILT CHECKS TYPE - A AT DRAINAGE OUTLETS.

NOTE:
PERIMETER EROSION CONTROL MEASURES SHALL BE INSTALLED DURING CLEARING AND GRUBBING PHASE.

NOTE:
UTILIZE TEMPORARY SEDIMENT BASIN OR SPECIAL STILLING BASIN(S) AS STILLING BASIN WHERE APPLICABLE.

8/17/99

7/12/2022 Environmental\Design\EC_Sheets\B-5806-EC_psh04.dgn

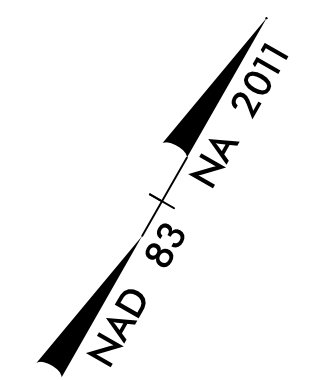

CLEARING AND GRUBBING
EROSION CONTROL FOR
CONSTRUCTION SHEET 5

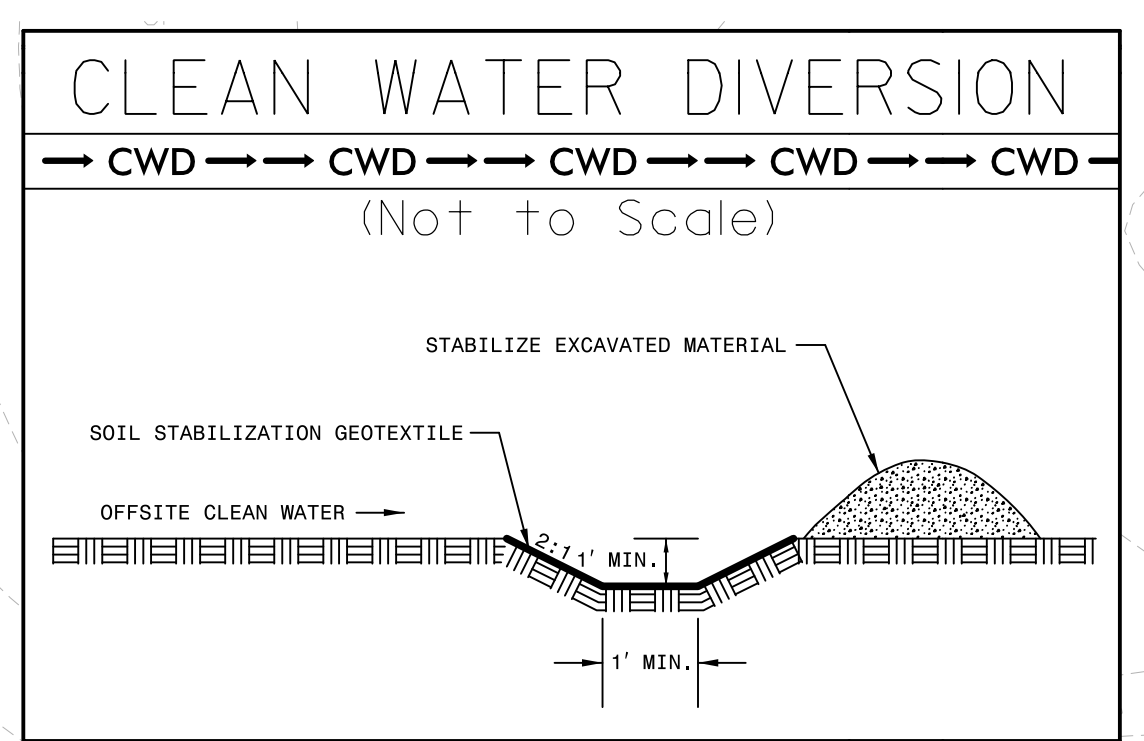
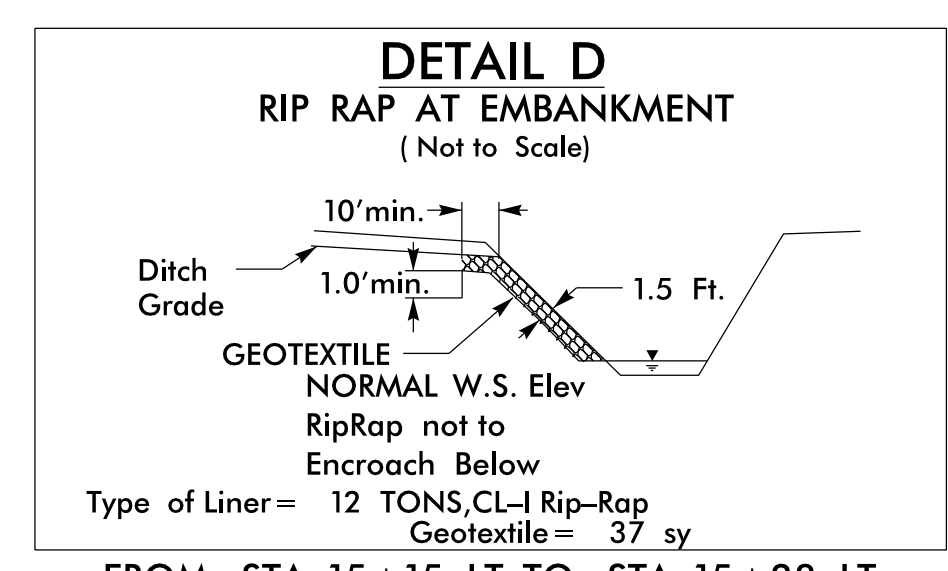
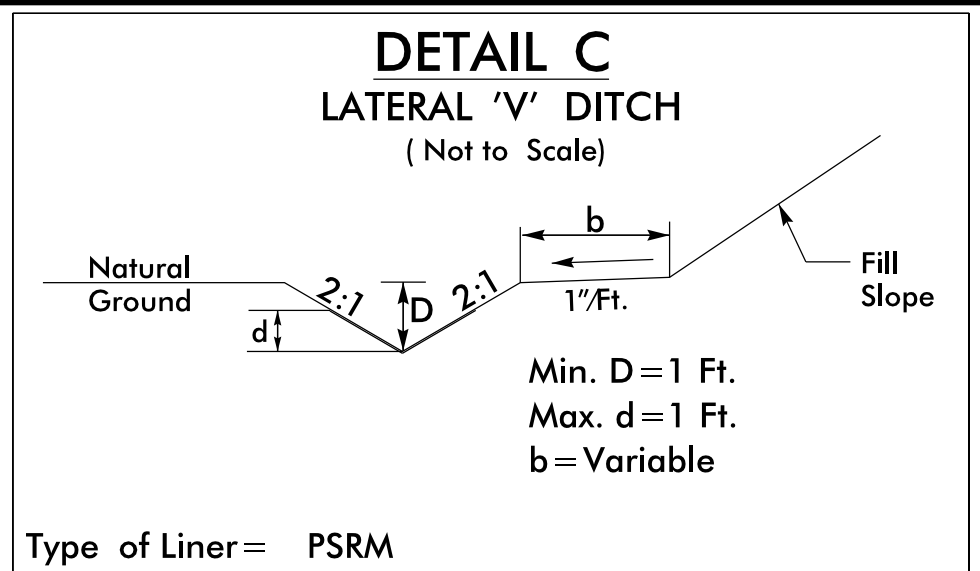
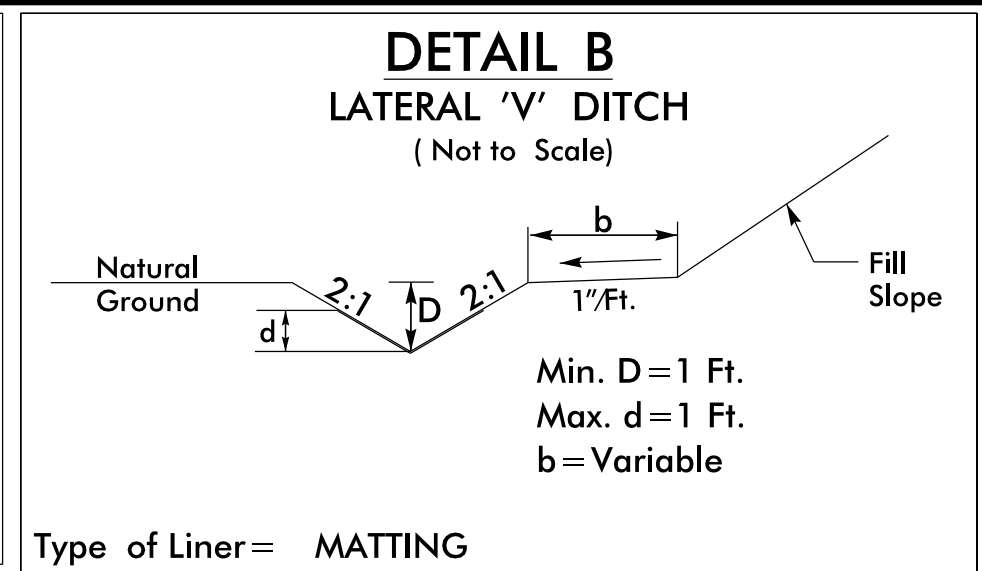
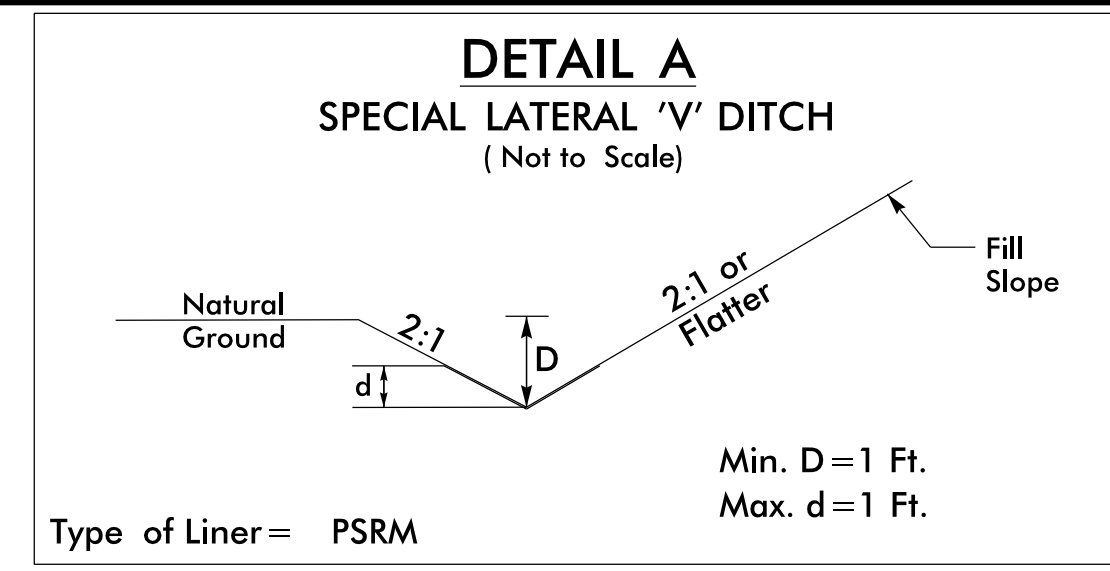

FROM STA. 15+15 LT TO STA. 15+28 LT
FROM STA. 15+54 LT TO STA. 15+67 LT
FROM STA. 15+10 RT TO STA. 15+35 RT
FROM STA. 15+62 RT TO STA. 15+69 RT

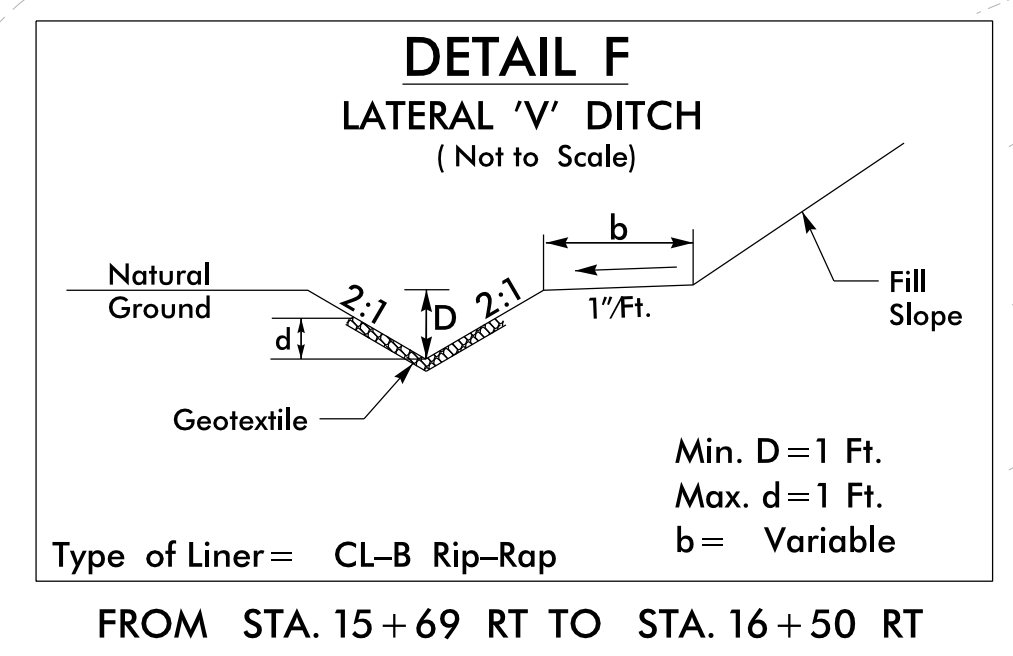
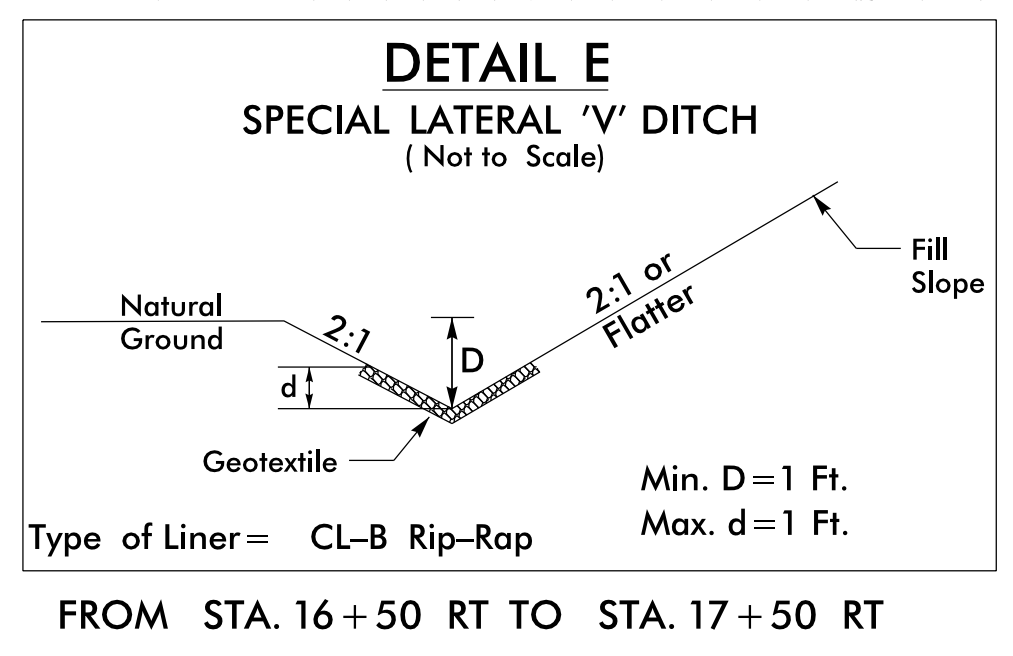
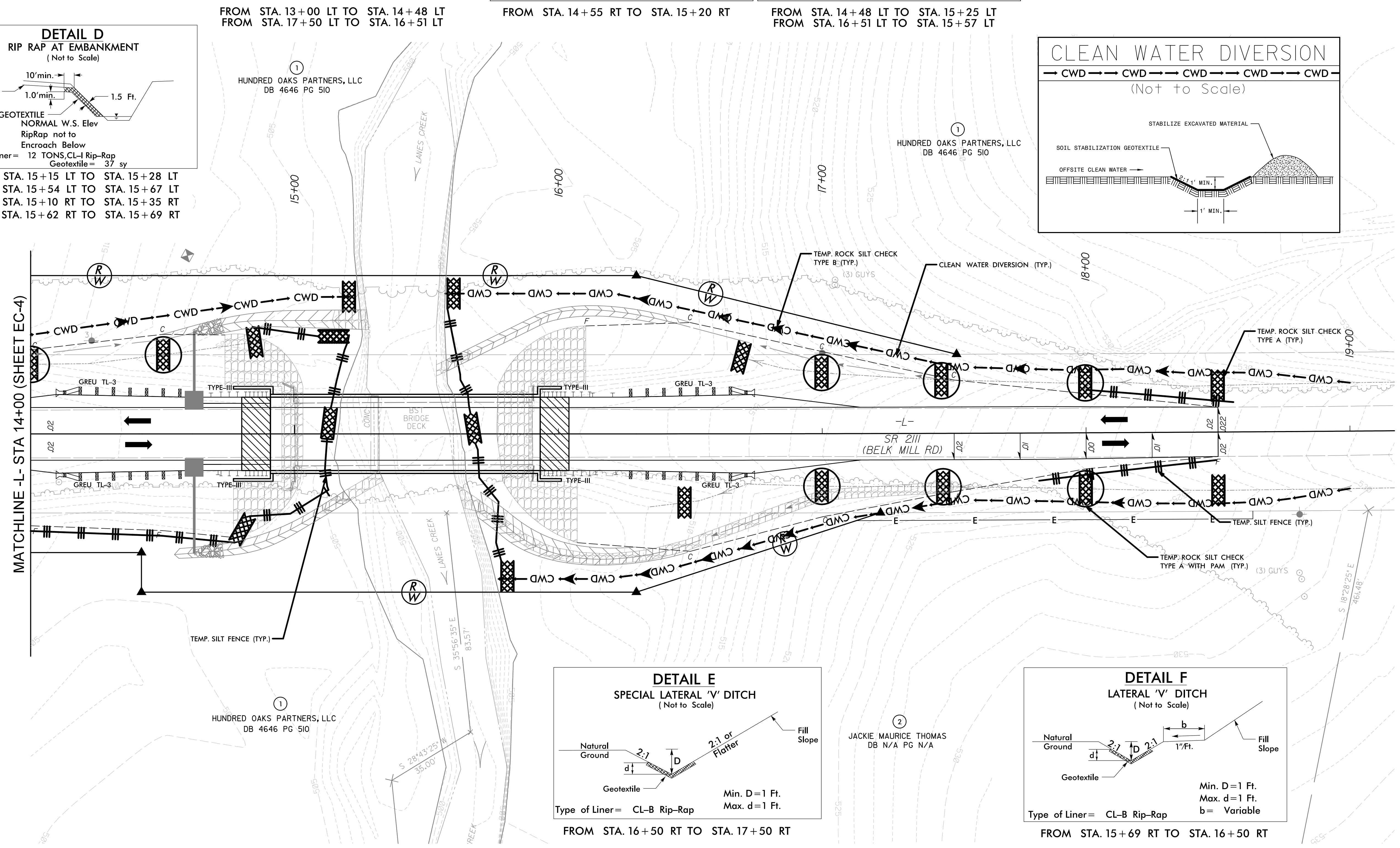

NOTE:
PLACE TEMPORARY ROCK SEDIMENT DAMS TYPE - B AND TEMPORARY ROCK SILT CHECKS TYPE - A AT DRAINAGE OUTLETS.

NOTE:
PERIMETER EROSION CONTROL MEASURES SHALL BE INSTALLED DURING CLEARING AND GRUBBING PHASE.

NOTE:
UTILIZE TEMPORARY SEDIMENT BASIN OR SPECIAL STILLING BASIN(S) AS STILLING BASIN WHERE APPLICABLE.

8/17/19
7/12/2022 Environmental\Design\EC_Sheets\B-5806-EC_psh05.dgn

FINAL EROSION CONTROL FOR
CONSTRUCTION SHEET 4

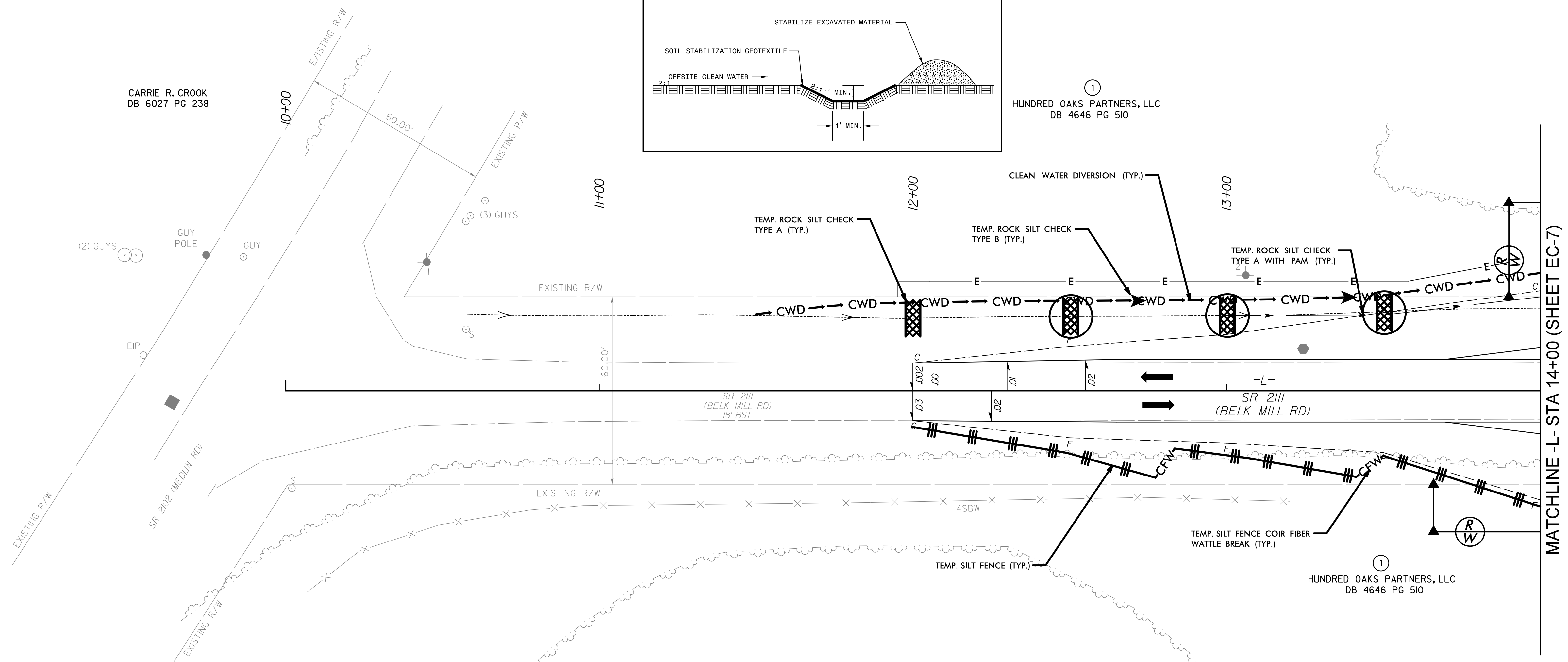
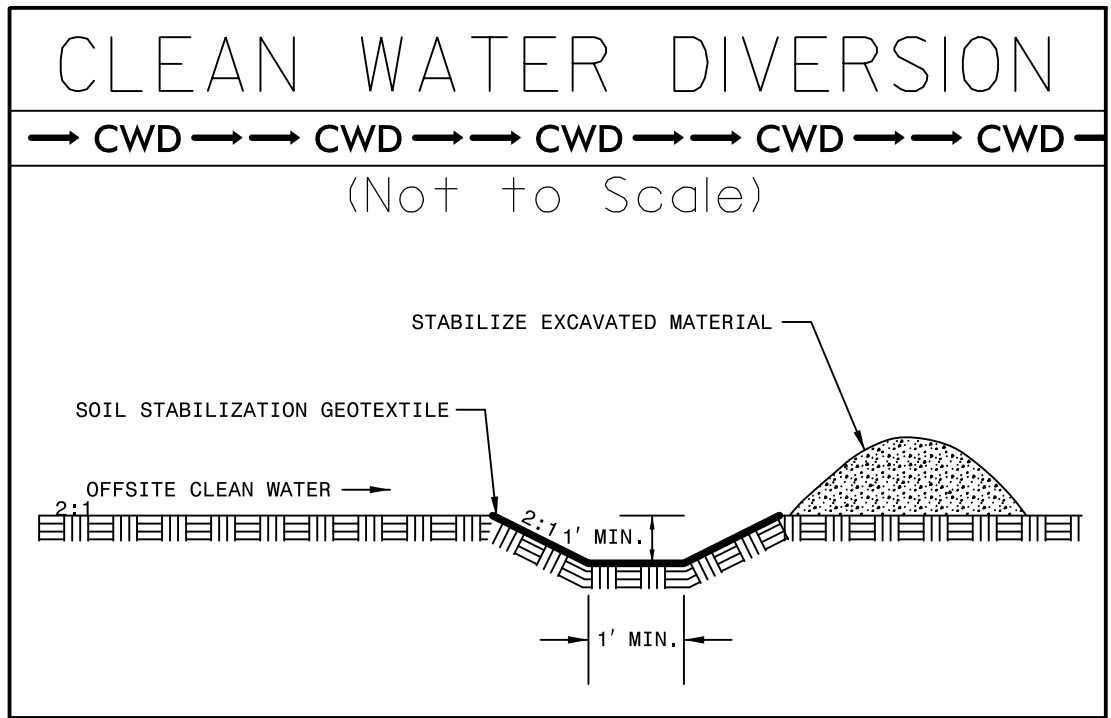
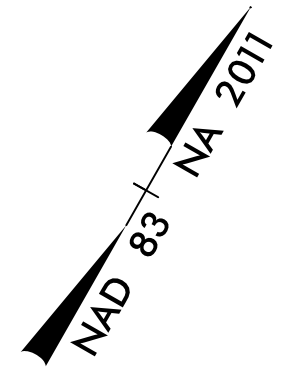
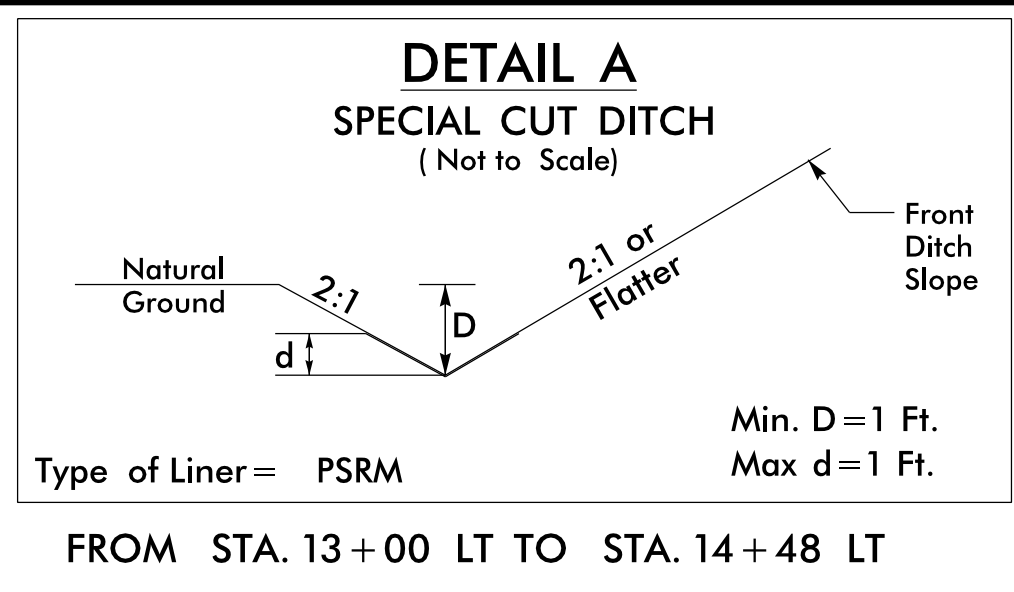

NOTE:
PLACE TEMPORARY ROCK SEDIMENT BASIN - B
AND TEMPORARY ROCK SILT CHECKS TYPE - A AT
DRAINAGE OUTLETS.

NOTE:
UTILIZE TEMPORARY SEDIMENT BASIN OR SPECIAL STILLING
BASIN(S) AS STILLING BASIN WHERE APPLICABLE.

8/17/99
7/12/2022
C:\Users\j\OneDrive\Documents\Design\EC_Sheets\B-5806-EC_psh06.dgn

FINAL EROSION CONTROL FOR CONSTRUCTION SHEET 5

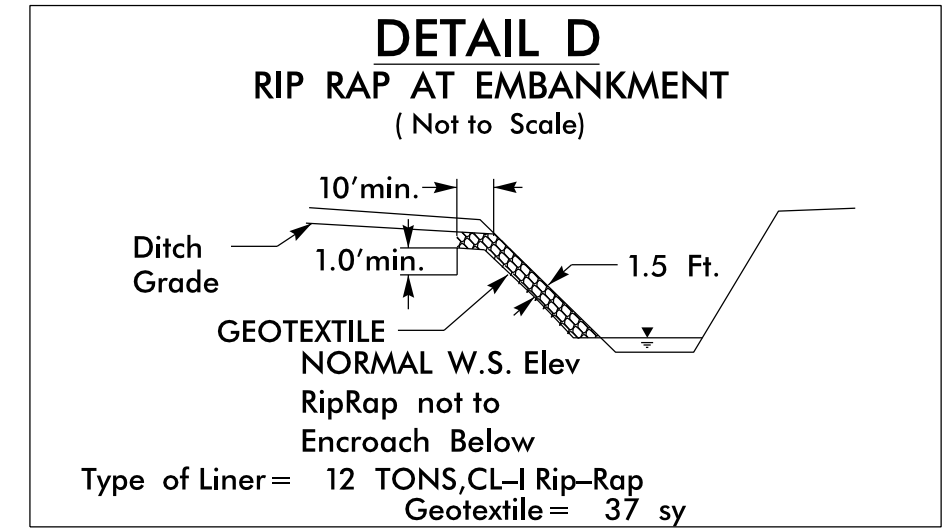
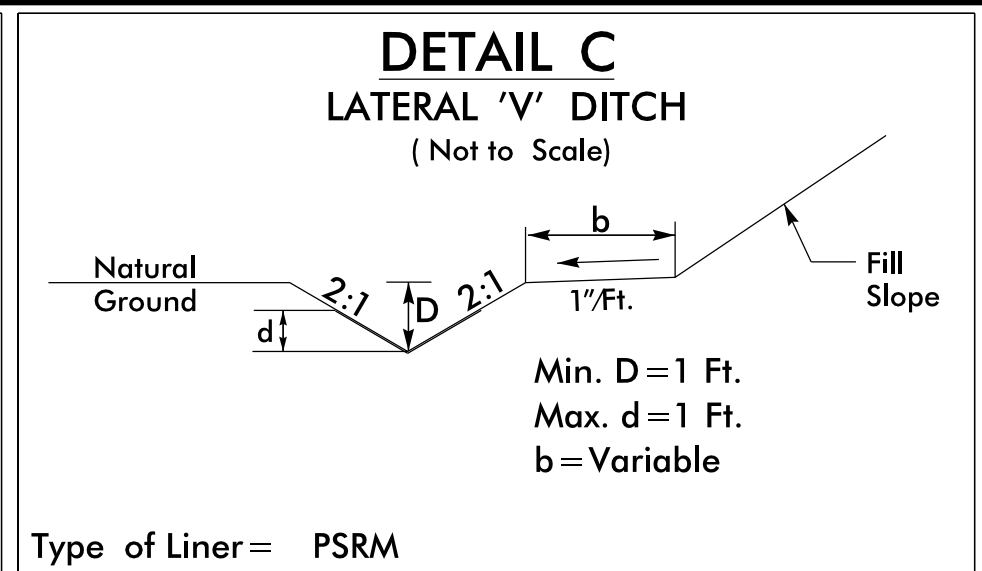
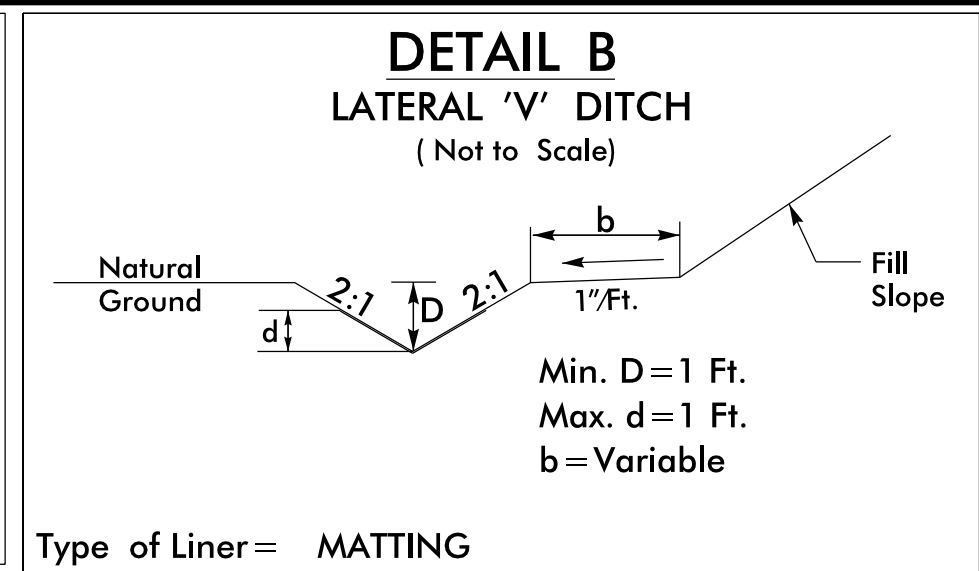
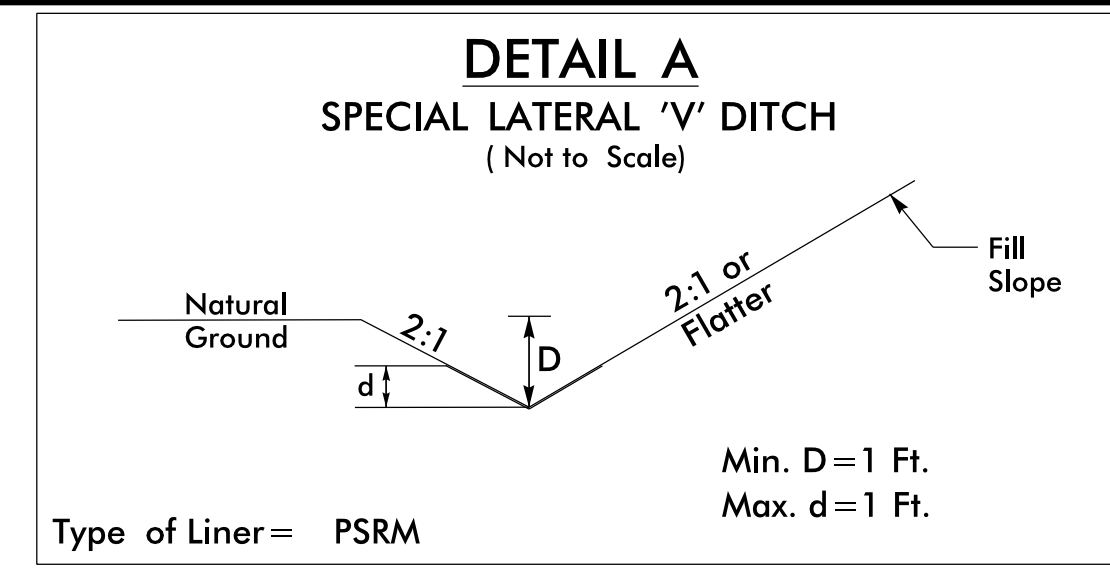

FROM STA. 15+15 LT TO STA. 15+28 LT
FROM STA. 15+54 LT TO STA. 15+67 LT
FROM STA. 15+10 RT TO STA. 15+35 RT
FROM STA. 15+62 RT TO STA. 15+69 RT

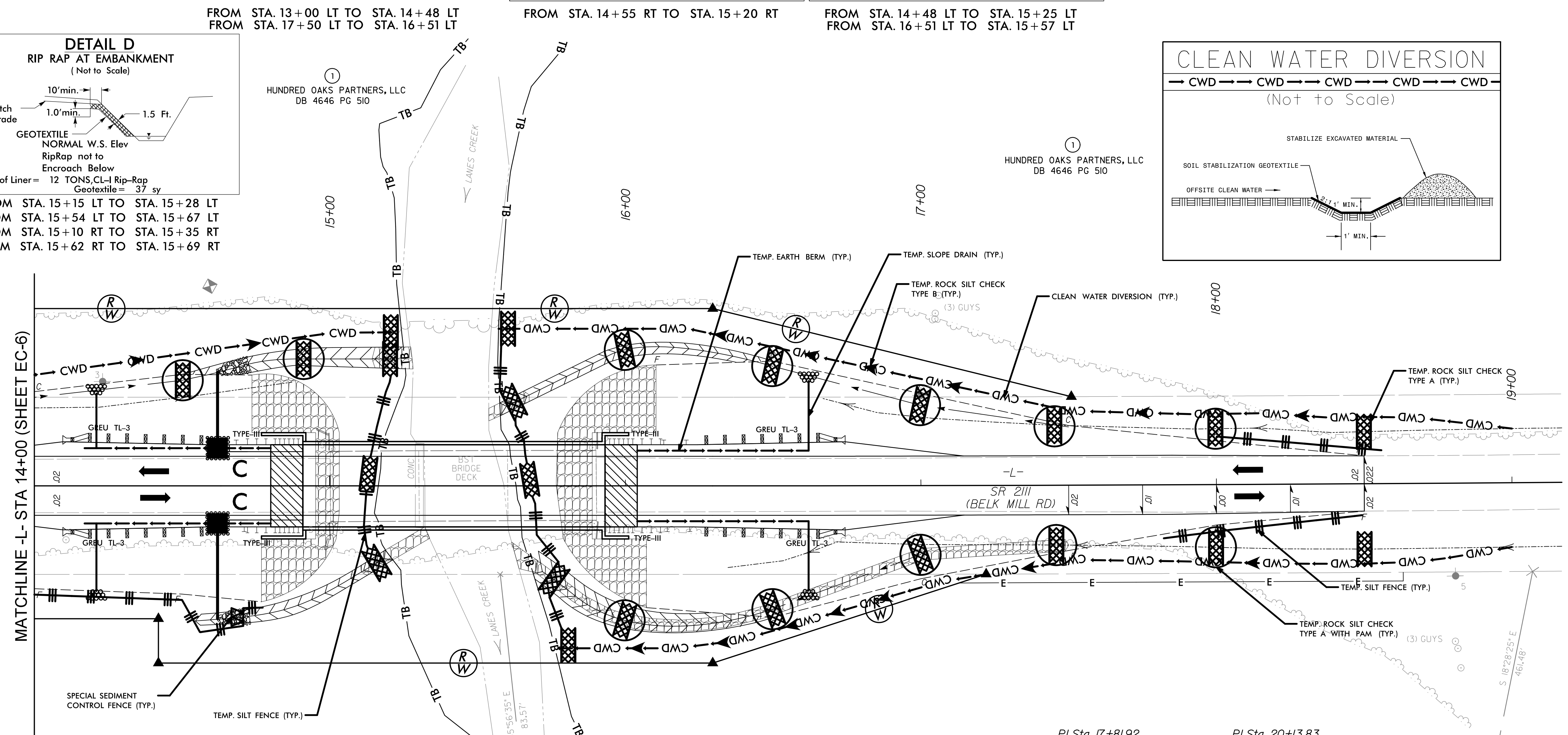
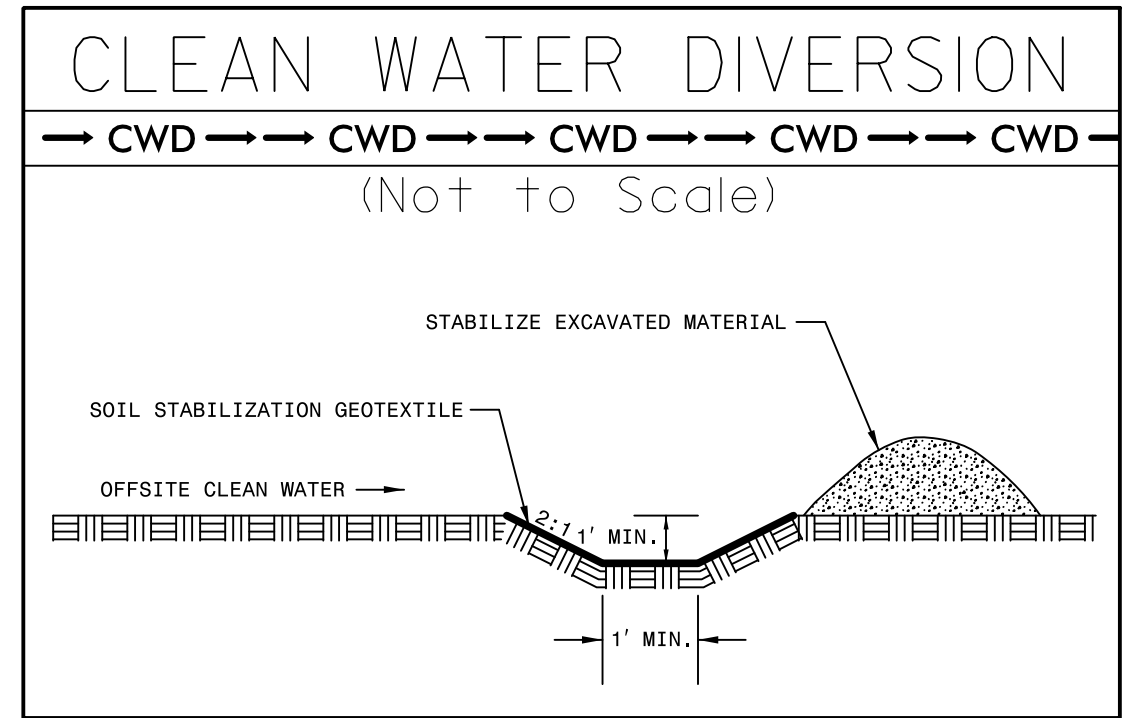

MATCHLINE -L- STA 14+00 (SHEET EC-6)

HUNDRED OAKS PARTNERS, LLC
DB 4646 PG 510

JACKIE MAURICE THOMAS
DB N/A PG N/A

PI Sta 17+81.92
Δ = 0° 29' 55.9" (LT)
D = 0' 09' 49.3"
L = 304.7'
T = 152.37'
R = 35,000.00'

PI Sta 20+13.83
Δ = 7° 35' 03.2" (LT)
D = 4' 46' 28.7"
L = 158.84'
T = 79.54'
R = 1,200.00'

NOTE:
PLACE TEMPORARY ROCK SEDIMENT DAMS TYPE - B AND TEMPORARY ROCK SILT CHECKS TYPE - A AT DRAINAGE OUTLETS.

NOTE:
UTILIZE TEMPORARY SEDIMENT BASIN OR SPECIAL STILLING BASIN(S) AS STILLING BASIN WHERE APPLICABLE.

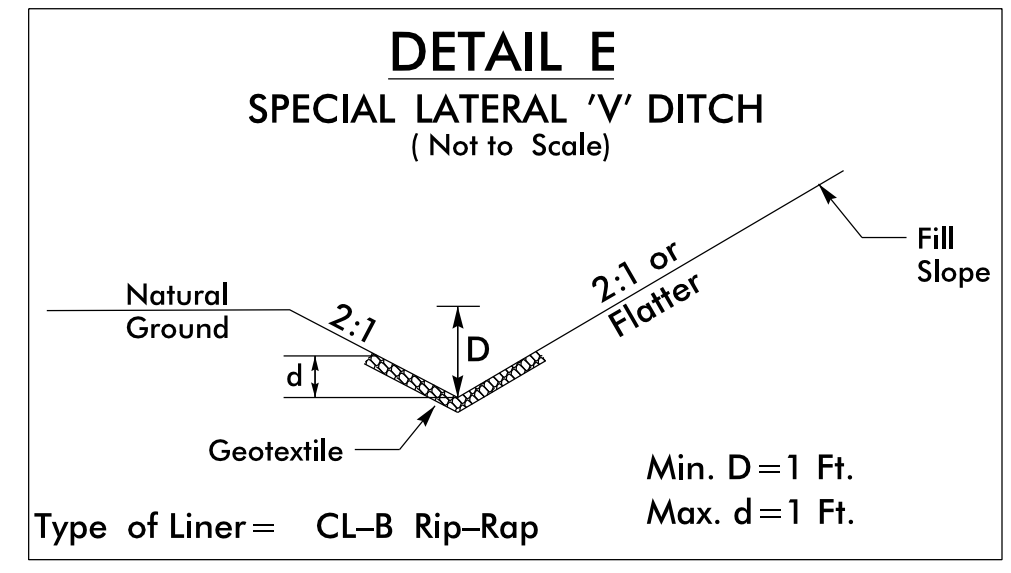

FROM STA. 16+50 RT TO STA. 17+50 RT

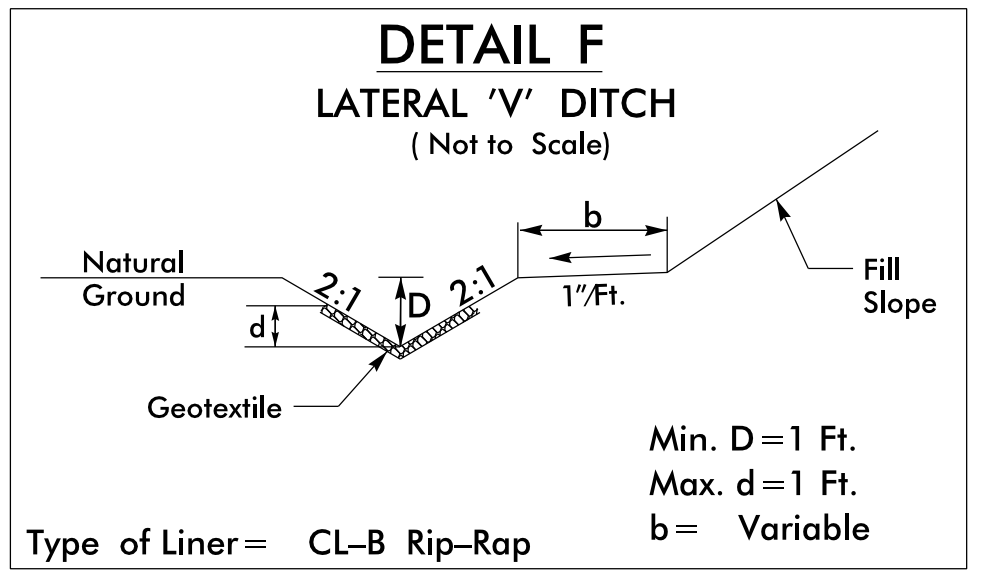

FROM STA. 15+69 RT TO STA. 16+50 RT

8/17/19
7/12/2022 Environmental\Design\EC_Sheets\B-5806-EC_psh07.dgn

6/23/16

0 2.5 5	PROJ. REFERENCE NO. B-5806	SHEET NO. X-1
---------	-------------------------------	------------------

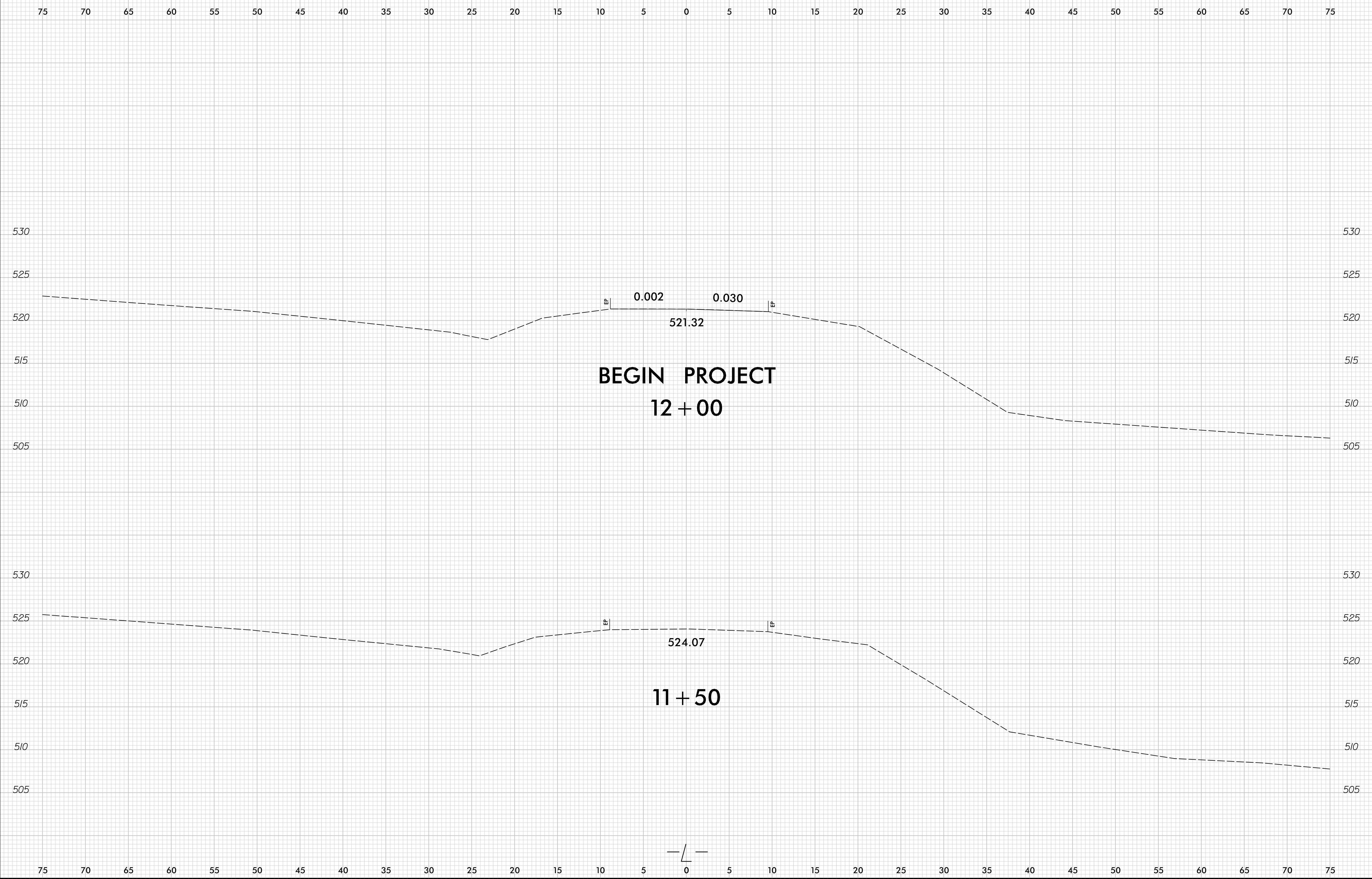

7/12/2022
R:\Roadway\Corridor Modeling\B-5806-FDY_xpl.dgn

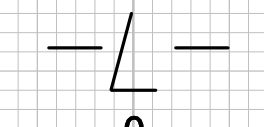

6/23/16

0 2.5 5	PROJ. REFERENCE NO. B-5806	SHEET NO. X-2
---------	-------------------------------	------------------

75 70 65 60 55 50 45 40 35 30 25 20 15 10 5 0 5 10 15 20 25 30 35 40 45 50 55 60 65 70 75

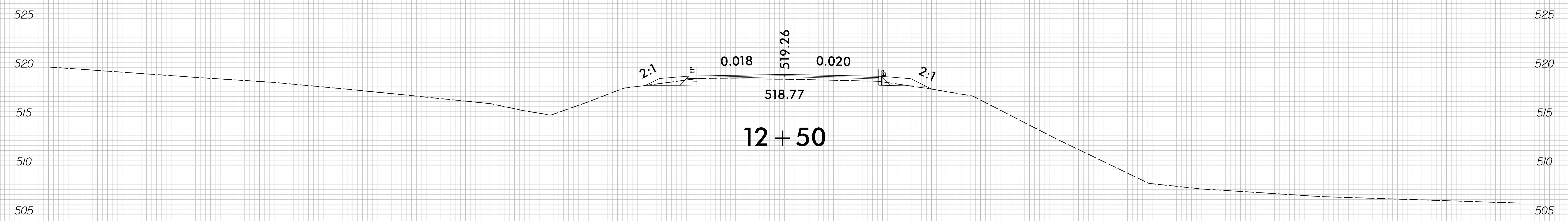
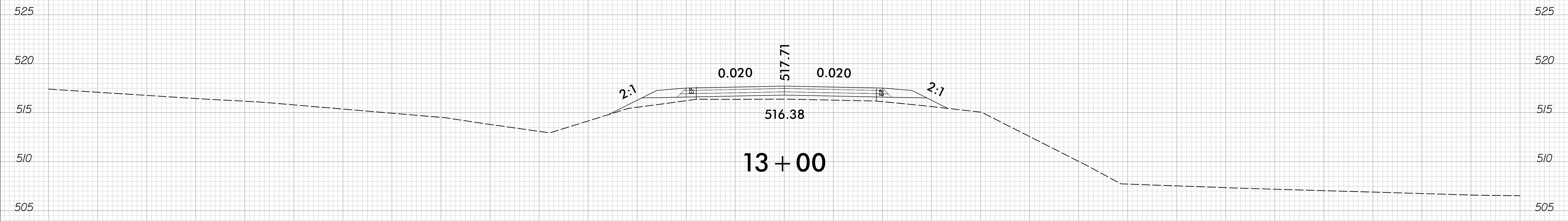

75 70 65 60 55 50 45 40 35 30 25 20 15 10 5 0 5 10 15 20 25 30 35 40 45 50 55 60 65 70 75

7/12/2022
 R:\Roadway\Corridor Modeling\B-5806-FDY_xpl.dgn
 10:12:51 AM

6/23/16

0 2.5 5	PROJ. REFERENCE NO. B-5806	SHEET NO. X-3
---------	-------------------------------	------------------

75 70 65 60 55 50 45 40 35 30 25 20 15 10 5 0 5 10 15 20 25 30 35 40 45 50 55 60 65 70 75

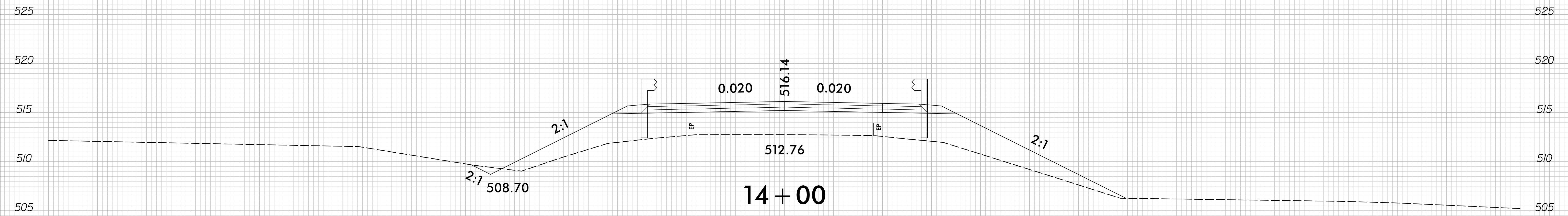

14 + 00

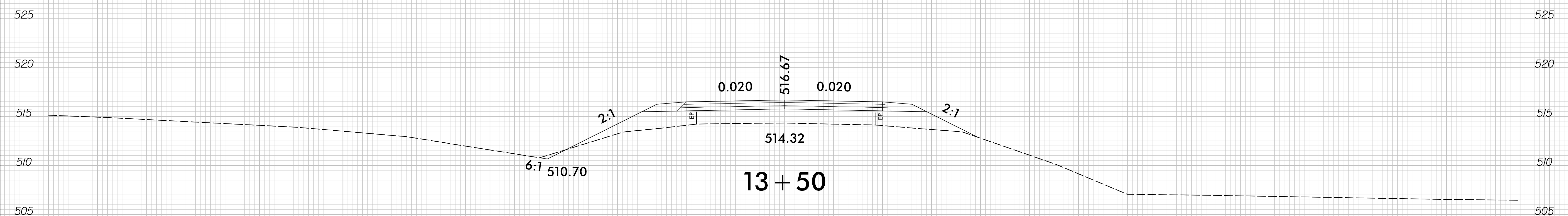

13 + 50

75 70 65 60 55 50 45 40 35 30 25 20 15 10 5 0 5 10 15 20 25 30 35 40 45 50 55 60 65 70 75

7/12/2022
R:\Roadway\Corridor Modeling\B-5806\FDY_xpl.dgn

6/23/16

0 2.5 5	PROJ. REFERENCE NO. B-5806	SHEET NO. X-4
---------	-------------------------------	------------------

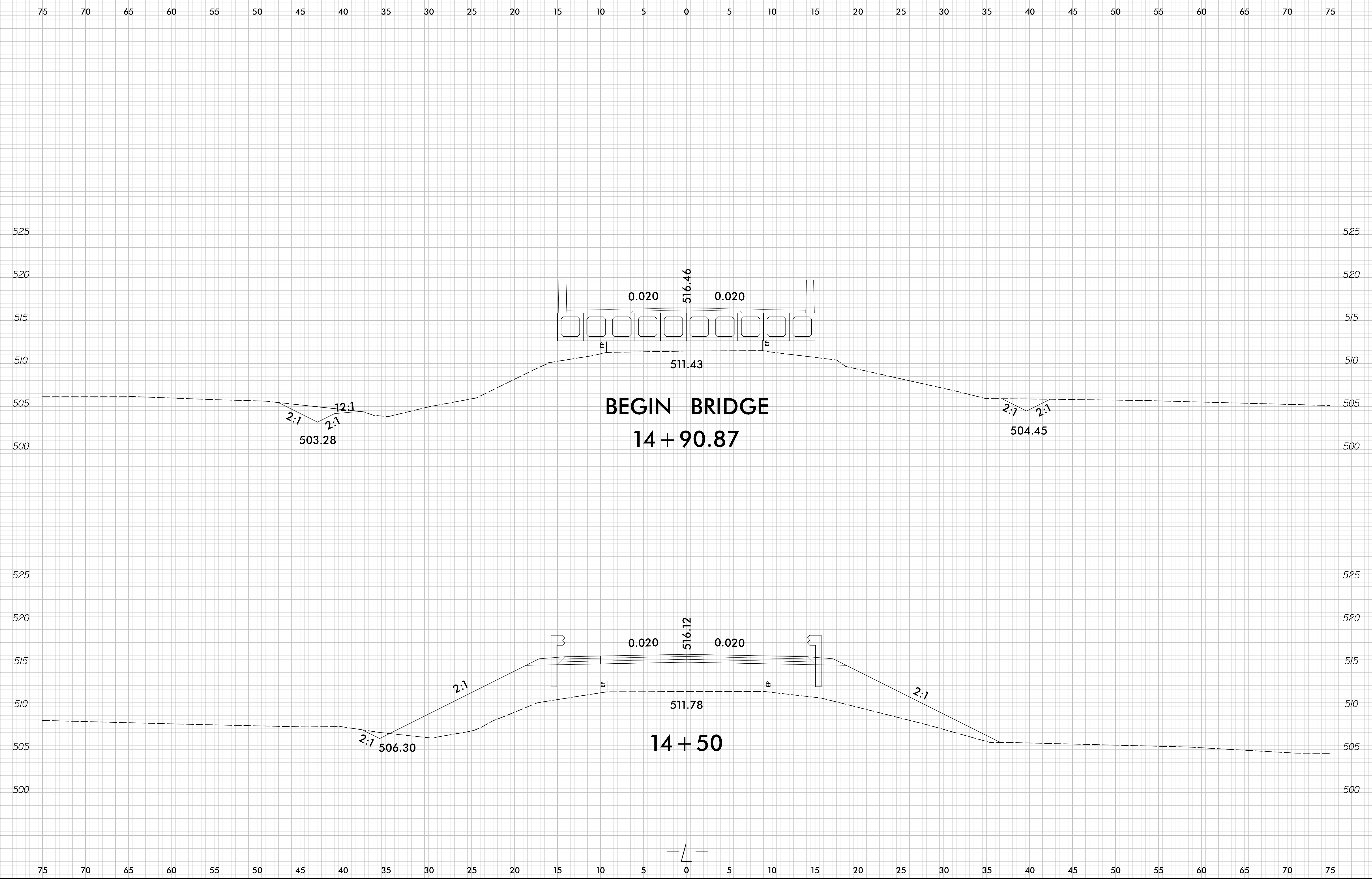

7/12/2022
R:\Roadway\Corridor Modeling\B-5806\FDY_xpl.dgn
faucite

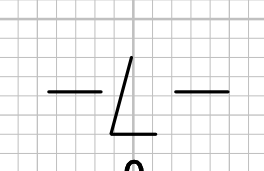

6/23/16

0 2.5 5	PROJ. REFERENCE NO. B-5806	SHEET NO. X-5
---------	-------------------------------	------------------

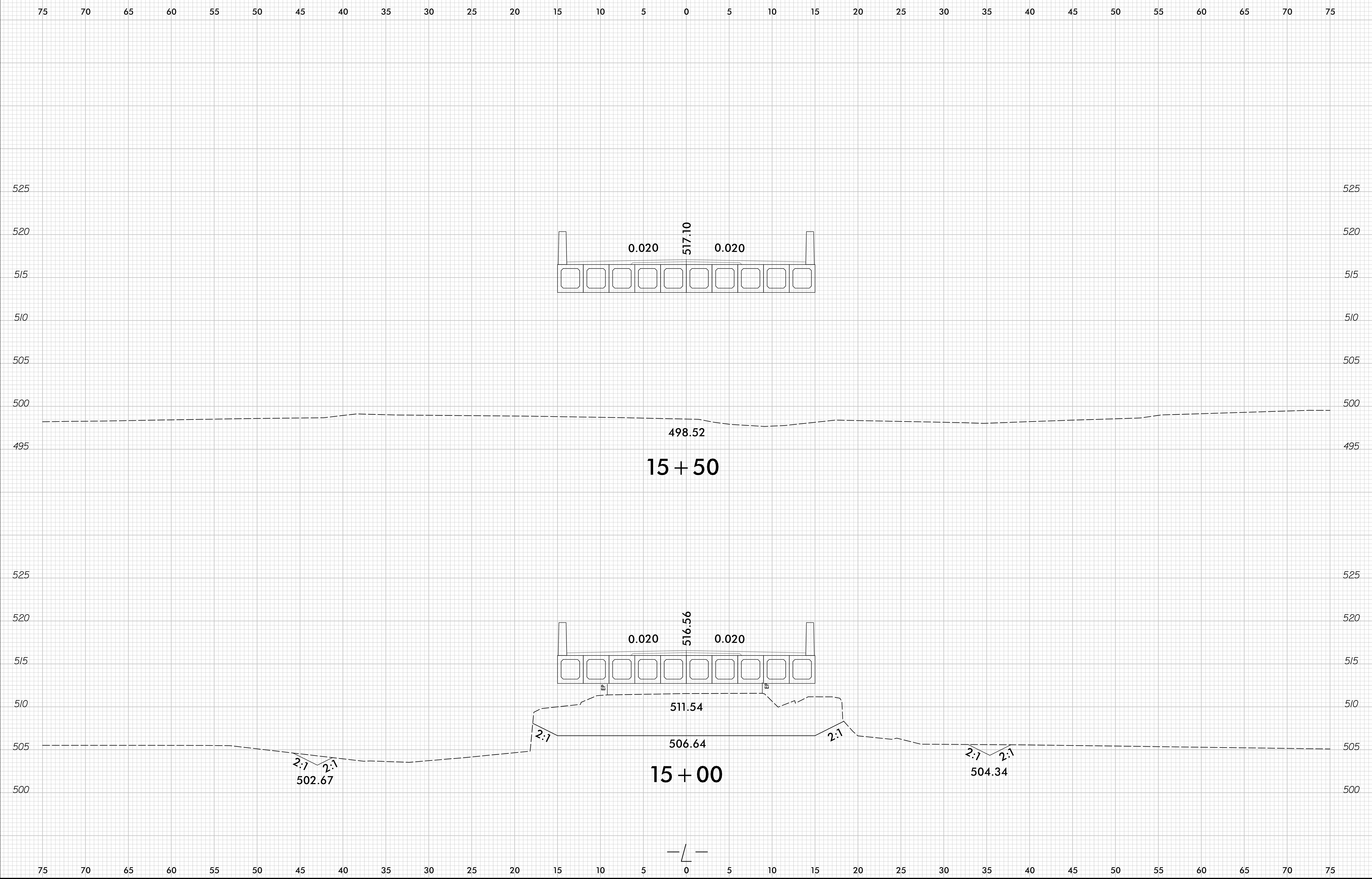

7/12/2022
R:\Roadway\Corridor Modeling\B-5806-FDY_xpl.dgn

6/23/16

0 2.5 5	PROJ. REFERENCE NO. B-5806	SHEET NO. X-6
---------	-------------------------------	------------------

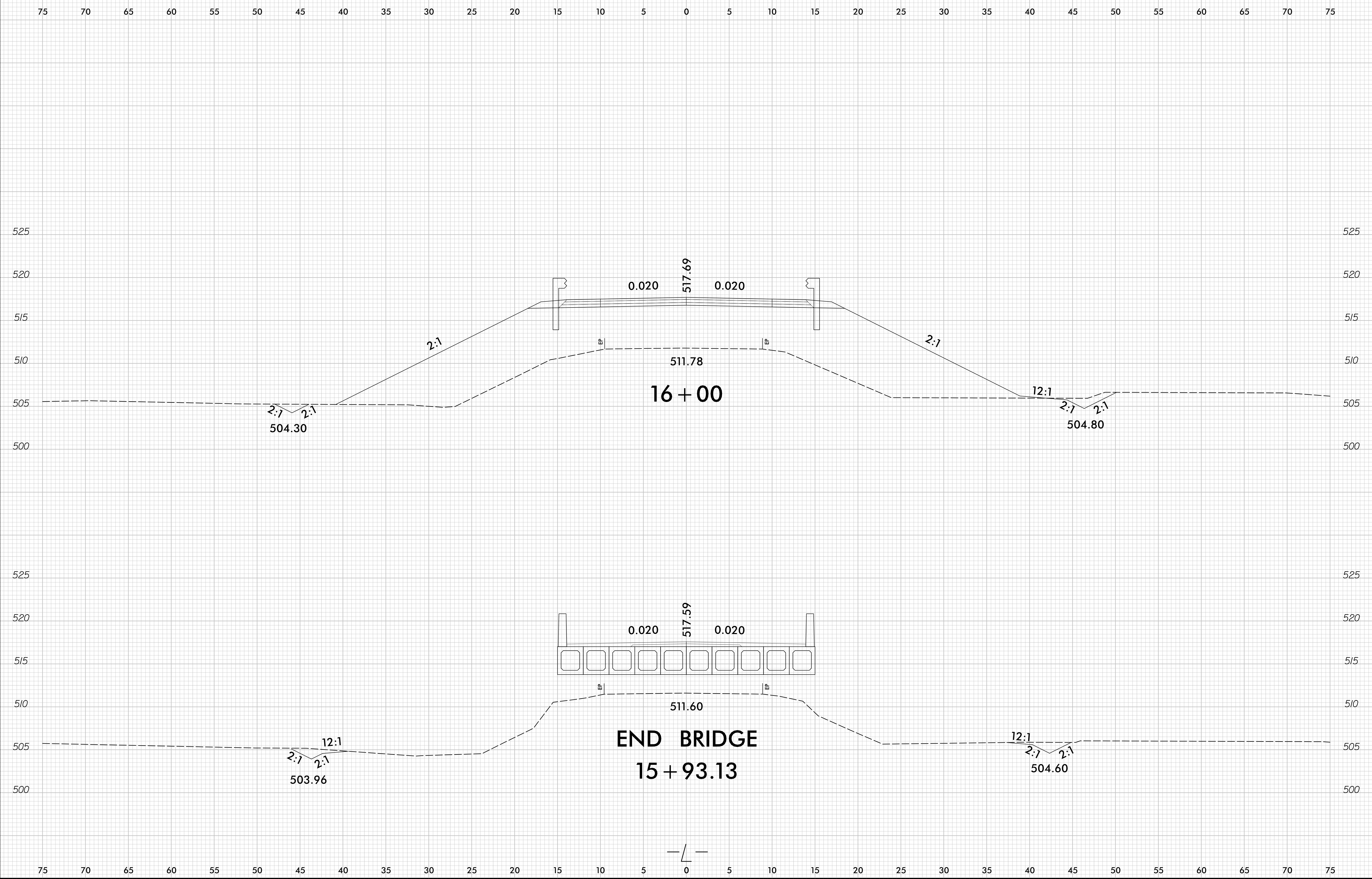

7/12/2022
R:\Roadway\Corridor Modeling\B-5806-FDY_xpl.dgn

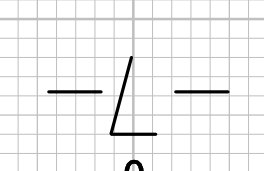

6/23/16

0 2.5 5	PROJ. REFERENCE NO. B-5806	SHEET NO. X-7
---------	-------------------------------	------------------

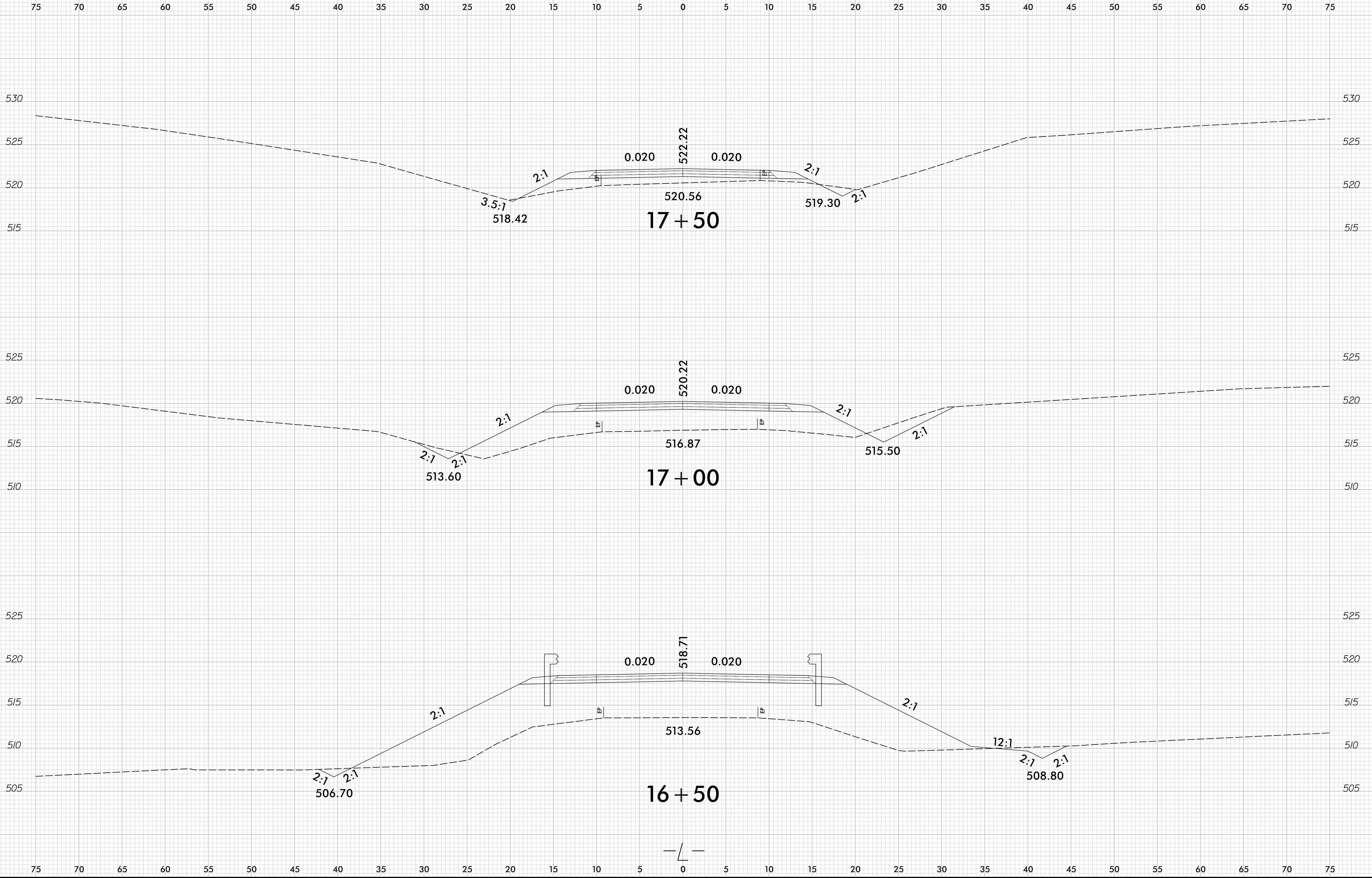

7/12/2022
R:\Roadway\Corridor Modeling\B-5806\FDY_xpl.dgn

6/23/16

0 2.5 5	PROJ. REFERENCE NO. B-5806	SHEET NO. X-8
---------	-------------------------------	------------------

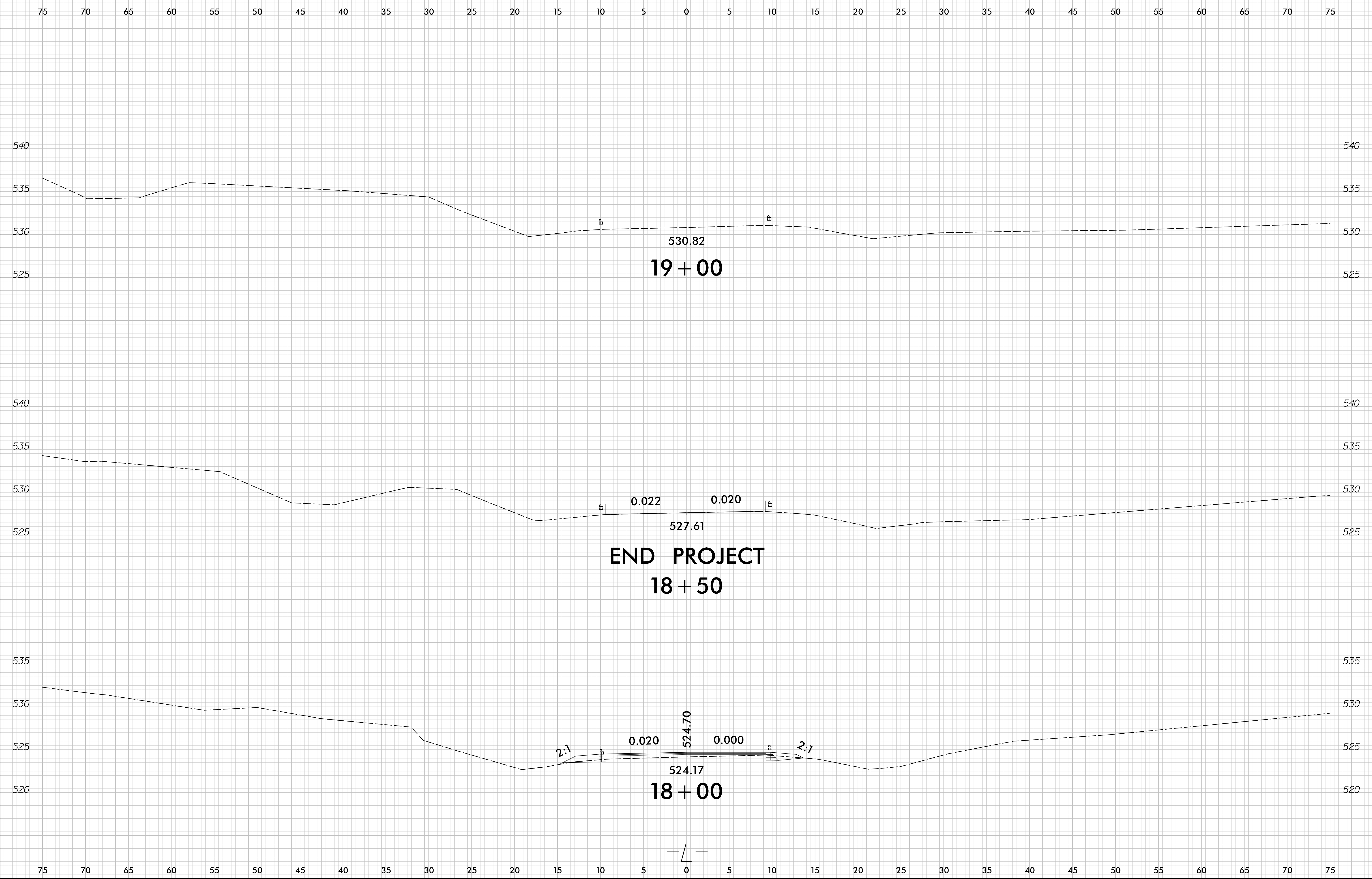

7/12/2022
R:\Roadway\Corridor Modeling\B-5806-FDY_xpl.dgn