

**This electronic collection of documents is provided
for the convenience of the user
and is Not a Certified Document –**

**The documents contained herein were originally issued
and sealed by the individuals whose names and license
numbers appear on each page, on the dates appearing
with their signature on that page.**

**This file or an individual page
shall not be considered a certified document.**

STATE PROJECT: 17BP.10.R.67

CONTRACT: DJ00235

See Sheet 1-A For Index of Sheets

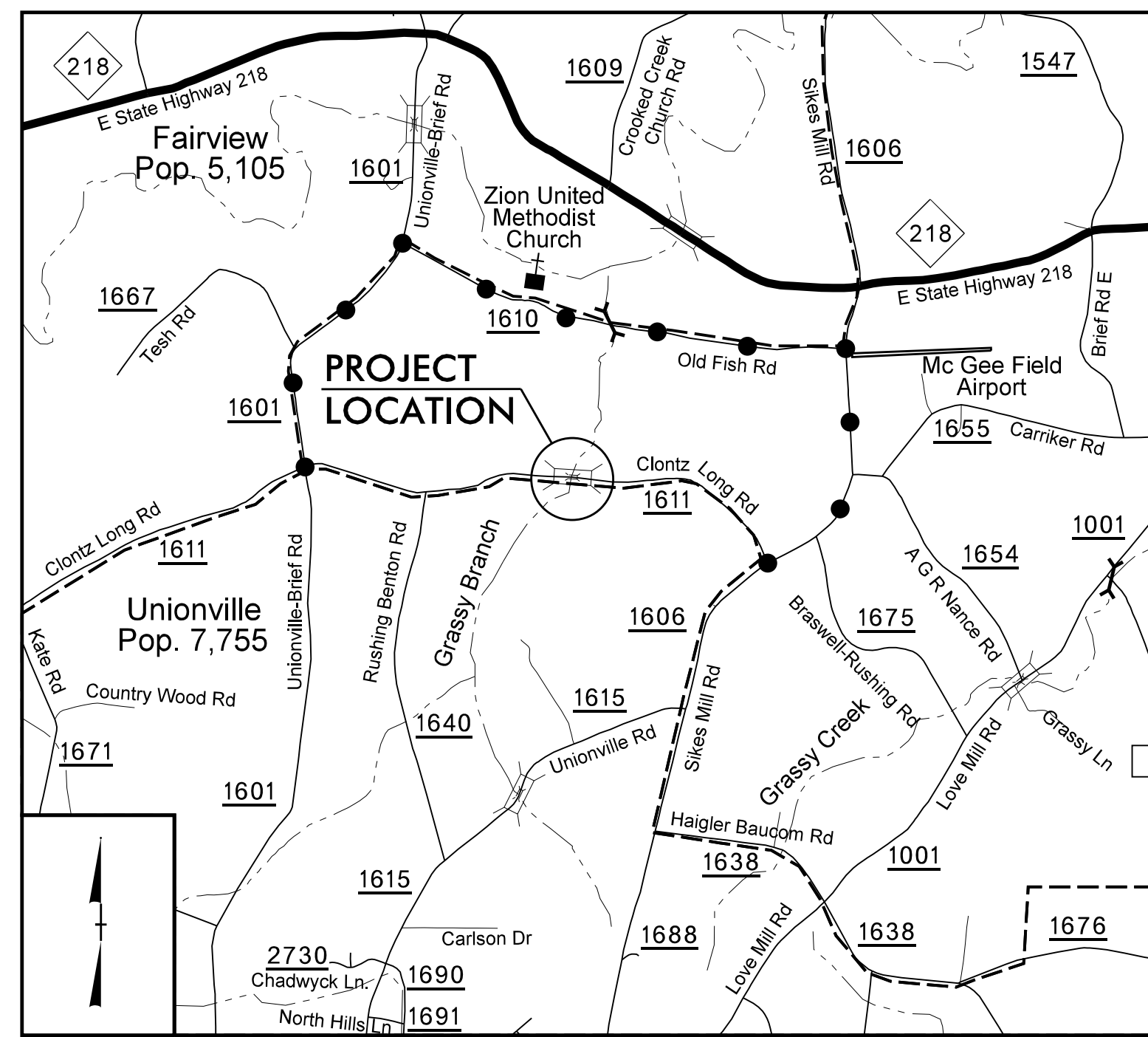

DETOUR ROUTE VICINITY MAP (NOT TO SCALE)

STATE OF NORTH CAROLINA
DIVISION OF HIGHWAYS

UNION COUNTY

LOCATION: BRIDGE NO. 410 ON SR 1611 OVER GRASSY BRANCH BETWEEN SR 1640 AND SR 1606

TYPE OF WORK: GRADING, DRAINAGE, PAVING AND STRUCTURE

| STATE | STATE PROJECT REFERENCE NO. | SHEET NO. | TOTAL SHEETS |
|-----------------|-----------------------------|--------------------|--------------|
| N.C. | 17BP.10.R.67 | 1 | |
| STATE PROJ. NO. | F.A. PROJ. NO. | DESCRIPTION | |
| 17BP.10.R.67 | | P.E., R/W, CONSTR. | |
| | | | |
| | | | |
| | | | |
| | | | |

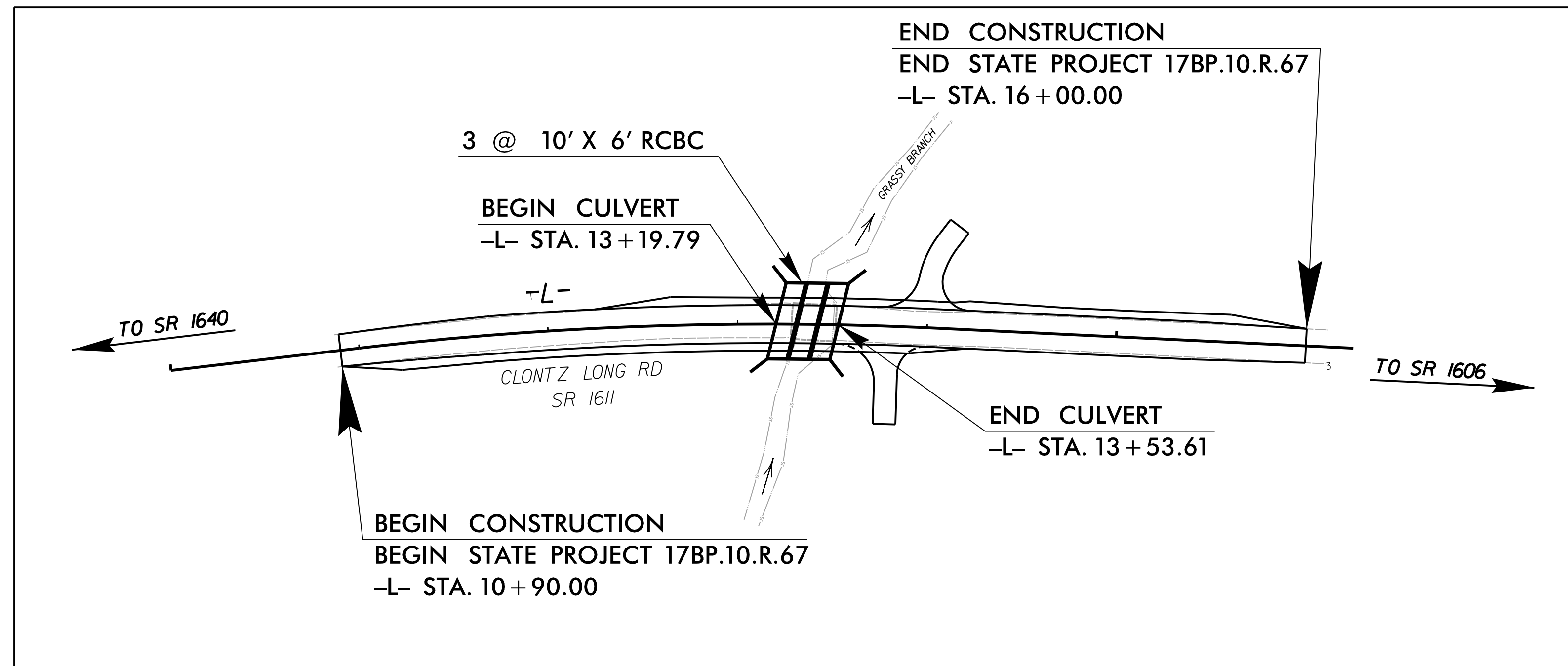
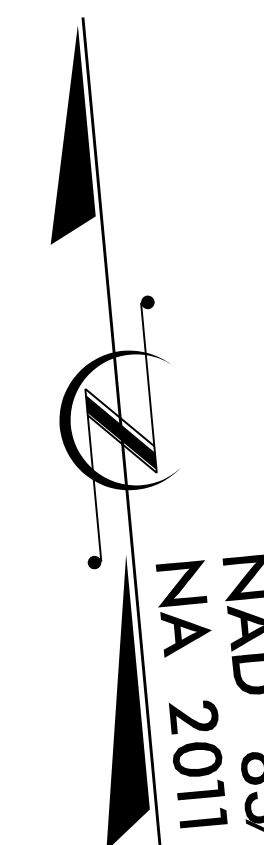

LOCATION SKETCH

A PORTION OF THIS PROJECT IS WITHIN THE MUNICIPAL BOUNDARIES OF UNIONVILLE.

HDR HDR Engineering, Inc. of the Carolinas
555 Fayetteville St, Suite 900 Raleigh, N.C. 27601
N.C.B.E.L.S. License Number: F-0116

DOCUMENT NOT CONSIDERED FINAL
UNLESS ALL SIGNATURES COMPLETED

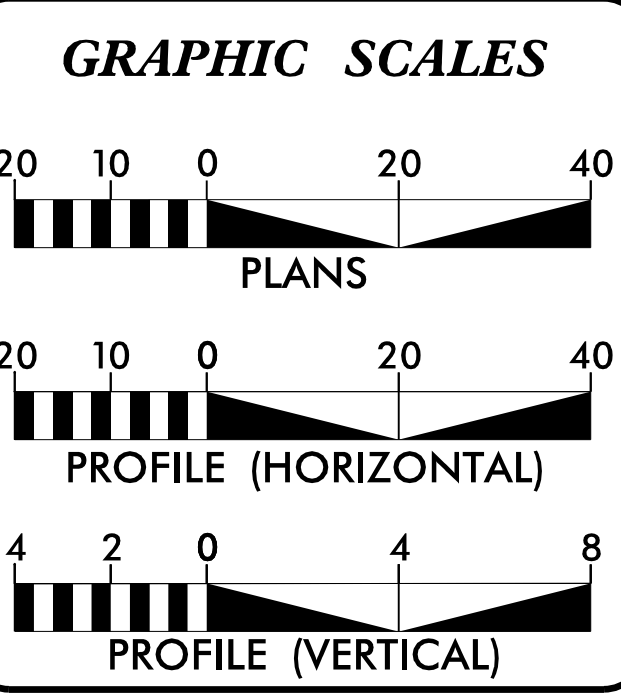

DESIGN DATA

| | |
|--------------|------------------------------|
| ADT 2011 = | 450 |
| ADT 2025 = | 1000 |
| DHV = | % |
| D = | % |
| T = | 6 % |
| V = | 55 MPH |
| FUNC CLASS = | LOCAL RURAL SUBREGIONAL TIER |

PROJECT LENGTH

| | |
|--|-------------|
| LENGTH ROADWAY STATE PROJECT 17BP.10.R.67 = | 0.091 MILES |
| LENGTH STRUCTURES STATE PROJECT 17BP.10.R.67 = | 0.006 MILES |
| TOTAL LENGTH STATE PROJECT 17BP.10.R.67 = | 0.097 MILES |

Prepared for the Office of:
DIVISION OF HIGHWAYS
1000 Birch Ridge Dr., Raleigh NC, 27610

| | |
|--|--|
| 2012 STANDARD SPECIFICATIONS | |
| RIGHT OF WAY DATE: FEBRUARY 18, 2015 | DOMINIC M. WAINWRIGHT, P.E. PROJECT ENGINEER |
| LETTING DATE: SEPTEMBER 6, 2017 | JAMES R. RICE, P.E. PROJECT DESIGN ENGINEER |

HYDRAULICS ENGINEER
8/1/2017



DocuSigned by:
[Signature]
SIGNATURE

ROADWAY DESIGN ENGINEER
8/1/2017

DocuSigned by:
[Signature]
SIGNATURE

DIVISION OF HIGHWAYS
STATE OF NORTH CAROLINA

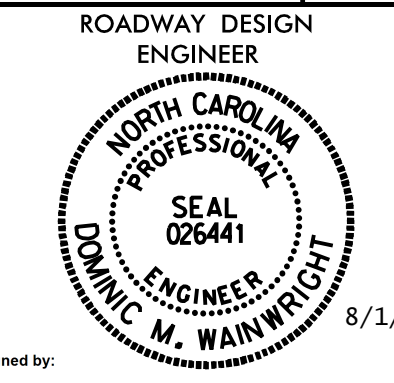
LOUIS MITCHELL P.E.
DIVISION ENGINEER

| | |
|---|-------------------------|
| PROJECT REFERENCE NO. <i>17BPJOR.67</i> | SHEET NO. <i>1-A</i> |
| ROADWAY DESIGN ENGINEER  8/1/2017 | |
| DOCUMENT NOT CONSIDERED FINAL UNLESS ALL SIGNATURES COMPLETED | |
|  HDR Engineering, Inc. of the Carolinas 555 Fayetteville St. Suite 900 Raleigh, N.C. 27601 N.C.B.E.L.S. License Number: F-0116 | |

| SHEET NUMBER | SHEET |
|------------------|--|
| 1 | TITLE SHEET |
| 1-A | INDEX OF SHEETS, GENERAL NOTES, AND LIST OF STANDARD DRAWINGS |
| 1-B | CONVENTIONAL SYMBOLS |
| 2 | PAVEMENT SCHEDULE AND TYPICAL SECTIONS |
| 2-A | MULTI-BARREL LOW FLOW CHANNEL AND FLOOD PLAN SILL DETAIL |
| 3 | RIGHT-OF-WAY AREA DATA, SUMMARY OF DRAINAGE QUANTITIES, SUMMARY OF GUARDRAIL |
| 4 | PLAN AND PROFILE SHEET |
| TMP-1 THRU TMP-2 | TRAFFIC MANAGEMENT PLAN |
| SD-01 | DETOUR SIGN DESIGN |
| EC-1 THRU EC-6 | EROSION CONTROL PLANS |
| UC-1 THRU UC-3 | UTILITY CONSTRUCTION PLANS |
| UO-1 THRU UO-2 | UTILITIES BY OTHERS PLANS |
| X-1 THRU X-6 | CROSS-SECTIONS |
| S-1 THRU S-7 | STRUCTURE PLANS |
| S-8 | STRUCTURE STANDARD NOTES |

GENERAL NOTES:

2012 SPECIFICATIONS
EFFECTIVE: 01-17-2012
REVISED: 01-24-2017

**GRADE LINE:
GRADING AND SURFACING:**

THE GRADE LINES SHOWN DENOTE THE FINISHED ELEVATION OF THE PROPOSED SURFACING AT GRADE POINTS SHOWN ON THE TYPICAL SECTIONS. GRADE LINES MAY BE ADJUSTED AT THEIR BEGINNING AND ENDING AND AT STRUCTURES AS DIRECTED BY THE ENGINEER IN ORDER TO SECURE A PROPER TIE-IN.

CLEARING:

CLEARING ON THIS PROJECT SHALL BE PERFORMED TO THE LIMITS ESTABLISHED BY METHOD II.

SUPERELEVATION:

ALL CURVES ON THIS PROJECT SHALL BE SUPERELEVATED IN ACCORDANCE WITH STD. NO. 225.04 USING THE RATE OF SUPERELEVATION AND RUNOFF SHOWN ON THE PLANS. SUPERELEVATION IS TO BE REVOLVED ABOUT THE GRADE POINTS SHOWN ON THE TYPICAL SECTIONS.

SHOULDER CONSTRUCTION:

ASPHALT, EARTH, AND CONCRETE SHOULDER CONSTRUCTION ON THE HIGH SIDE OF SUPERELEVATED CURVES SHALL BE IN ACCORDANCE WITH STD. NO. 560.01

SIDE ROADS:

THE CONTRACTOR WILL BE REQUIRED TO DO ALL NECESSARY WORK TO PROVIDE SUITABLE CONNECTIONS WITH ALL ROADS, STREETS, AND DRIVES ENTERING THIS PROJECT. THIS WORK WILL BE PAID FOR AT THE CONTRACT UNIT PRICE FOR THE PARTICULAR ITEMS INVOLVED.

DRIVEWAYS:

DRIVEWAYS SHALL BE CONSTRUCTED IN ACCORDANCE WITH STD. 848.02 USING 15 FOOT RADII OR RADII AS SHOWN ON THE PLANS. LOCATIONS OF DRIVES WILL BE AS SHOWN ON THE PLANS OR AS DIRECTED BY THE ENGINEER.

GUARDRAIL:

THE GUARDRAIL LOCATIONS SHOWN ON THE PLANS MAY BE ADJUSTED DURING CONSTRUCTION AS DIRECTED BY THE ENGINEER. THE CONTRACTOR SHOULD CONSULT WITH THE ENGINEER PRIOR TO ORDERING GUARDRAIL MATERIAL.

UTILITIES:

UTILITY OWNERS ON THIS PROJECT ARE FRONTIER COMMUNICATIONS AND UNION COUNTY PUBLIC WORKS.

ANY RELOCATION OF EXISTING UTILITIES WILL BE ACCOMPLISHED BY OTHERS, EXCEPT AS SHOWN ON THE PLANS.

RIGHT-OF-WAY MARKERS:

ALL RIGHT-OF-WAY MARKERS ON THIS PROJECT SHALL BE PLACED BY OTHERS.

EFF. 01-17-2012
REV. 02-29-2016

2012 ROADWAY ENGLISH STANDARD DRAWINGS

The following Roadway Standards as appear in "Roadway Standard Drawings" Highway Design Branch - N. C. Department of Transportation - Raleigh, N. C., Dated January, 2012 are applicable to this project and by reference hereby are considered a part of these plans:

| STD.NO. | TITLE |
|--|---|
| DIVISION 2 - EARTHWORK | |
| 200.02 | Method of Clearing - Method II |
| 225.02 | Guide for Grading Subgrade - Secondary and Local |
| 225.04 | Method of Obtaining Superelevation - Two Lane Pavement |
| DIVISION 3 - PIPE CULVERTS | |
| 300.01 | Method of Pipe Installation |
| 310.10 | Driveway Pipe Construction |
| DIVISION 5 - SUBGRADE, BASES AND SHOULDERS | |
| 560.01 | Method of Shoulder Construction - High Side of Superelevated Curve - Method I |
| DIVISION 8 - INCIDENTALS | |
| 848.02 | Driveway Turnout - Radius Type |
| 862.01 | Guardrail Placement |
| 862.02 | Guardrail Installation |
| 866.03 | Woven Wire Fence - with Steel Post |
| 876.01 | Rip Rap in Channels |

STATE OF NORTH CAROLINA, DIVISION OF HIGHWAYS CONVENTIONAL PLAN SHEET SYMBOLS

Note: Not to Scale

*S.U.E. = Subsurface Utility Engineering

BOUNDARIES AND PROPERTY:

| | |
|---------------------------------------|-----------|
| State Line | ----- |
| County Line | ----- |
| Township Line | ----- |
| City Line | ----- |
| Reservation Line | ----- |
| Property Line | ----- |
| Existing Iron Pin | ○ |
| Property Corner | ⊠ |
| Property Monument | ⊠ |
| Parcel/Sequence Number | Ⓜ |
| Existing Fence Line | —x—x—x— |
| Proposed Woven Wire Fence | —○— |
| Proposed Chain Link Fence | —□— |
| Proposed Barbed Wire Fence | —◇— |
| Existing Wetland Boundary | ---WLB--- |
| Proposed Wetland Boundary | ---WLB--- |
| Existing Endangered Animal Boundary | ---EAB--- |
| Existing Endangered Plant Boundary | ---EPB--- |
| Existing Historic Property Boundary | ---HPB--- |
| Known Contamination Area: Soil | ☠☠ |
| Potential Contamination Area: Soil | ☠☠ |
| Known Contamination Area: Water | ☠☠ |
| Potential Contamination Area: Water | ☠☠ |
| Contaminated Site: Known or Potential | ☠☠ |

BUILDINGS AND OTHER CULTURE:

| | |
|-------------------------------|---|
| Gas Pump Vent or U/G Tank Cap | ○ |
| Sign | Ⓞ |
| Well | Ⓜ |
| Small Mine | ⊠ |
| Foundation | ⊠ |
| Area Outline | ⊠ |
| Cemetery | ⊠ |
| Building | ⊠ |
| School | ⊠ |
| Church | ⊠ |
| Dam | ⊠ |

HYDROLOGY:

| | |
|------------------------------------|------------|
| Stream or Body of Water | ----- |
| Hydro, Pool or Reservoir | ----- |
| Jurisdictional Stream | ---JS--- |
| Buffer Zone 1 | ---BZ 1--- |
| Buffer Zone 2 | ---BZ 2--- |
| Flow Arrow | ← |
| Disappearing Stream | ----- |
| Spring | ○ |
| Wetland | ---WLB--- |
| Proposed Lateral, Tail, Head Ditch | ----- |
| False Sump | ----- |

RAILROADS:

| | |
|--------------------|-------|
| Standard Gauge | ----- |
| RR Signal Milepost | ----- |
| Switch | ----- |
| RR Abandoned | ----- |
| RR Dismantled | ----- |

RIGHT OF WAY:

| | |
|---|-------|
| Baseline Control Point | ◆ |
| Existing Right of Way Marker | △ |
| Existing Right of Way Line | ----- |
| Proposed Right of Way Line | ----- |
| Proposed Right of Way Line with Iron Pin and Cap Marker | ----- |
| Proposed Right of Way Line with Concrete or Granite RW Marker | ----- |
| Proposed Control of Access Line with Concrete CA Marker | ----- |
| Existing Control of Access | ----- |
| Proposed Control of Access | ----- |
| Existing Easement Line | ----- |
| Proposed Temporary Construction Easement | ----- |
| Proposed Temporary Drainage Easement | ----- |
| Proposed Permanent Drainage Easement | ----- |
| Proposed Permanent Drainage / Utility Easement | ----- |
| Proposed Permanent Utility Easement | ----- |
| Proposed Temporary Utility Easement | ----- |
| Proposed Aerial Utility Easement | ----- |
| Proposed Permanent Easement with Iron Pin and Cap Marker | ----- |

ROADS AND RELATED FEATURES:

| | |
|----------------------------|-------|
| Existing Edge of Pavement | ----- |
| Existing Curb | ----- |
| Proposed Slope Stakes Cut | ----- |
| Proposed Slope Stakes Fill | ----- |
| Proposed Curb Ramp | ----- |
| Existing Metal Guardrail | ----- |
| Proposed Guardrail | ----- |
| Existing Cable Guiderail | ----- |
| Proposed Cable Guiderail | ----- |
| Equality Symbol | ⊕ |
| Pavement Removal | ----- |

VEGETATION:

| | |
|--------------|-------|
| Single Tree | ☀ |
| Single Shrub | ☀ |
| Hedge | ----- |
| Woods Line | ----- |

| | |
|----------|-------|
| Orchard | ----- |
| Vineyard | ----- |

EXISTING STRUCTURES:

| | |
|--|-------|
| MAJOR: | |
| Bridge, Tunnel or Box Culvert | ----- |
| Bridge Wing Wall, Head Wall and End Wall | ----- |
| MINOR: | |
| Head and End Wall | ----- |
| Pipe Culvert | ----- |
| Footbridge | ----- |
| Drainage Box: Catch Basin, DI or JB | ----- |
| Paved Ditch Gutter | ----- |
| Storm Sewer Manhole | ----- |
| Storm Sewer | ----- |

UTILITIES:

| | |
|--------------------------------|-------|
| POWER: | |
| Existing Power Pole | ● |
| Proposed Power Pole | ○ |
| Existing Joint Use Pole | ● |
| Proposed Joint Use Pole | ○ |
| Power Manhole | Ⓜ |
| Power Line Tower | ⊠ |
| Power Transformer | ⊠ |
| U/G Power Cable Hand Hole | Ⓜ |
| H-Frame Pole | ● |
| U/G Power Line LOS B (S.U.E.*) | ----- |
| U/G Power Line LOS C (S.U.E.*) | ----- |
| U/G Power Line LOS D (S.U.E.*) | ----- |

TELEPHONE:

| | |
|--|-------|
| Existing Telephone Pole | ● |
| Proposed Telephone Pole | ○ |
| Telephone Manhole | Ⓜ |
| Telephone Pedestal | ⊠ |
| Telephone Cell Tower | ⊠ |
| U/G Telephone Cable Hand Hole | Ⓜ |
| U/G Telephone Cable LOS B (S.U.E.*) | ----- |
| U/G Telephone Cable LOS C (S.U.E.*) | ----- |
| U/G Telephone Cable LOS D (S.U.E.*) | ----- |
| U/G Telephone Conduit LOS B (S.U.E.*) | ----- |
| U/G Telephone Conduit LOS C (S.U.E.*) | ----- |
| U/G Telephone Conduit LOS D (S.U.E.*) | ----- |
| U/G Fiber Optics Cable LOS B (S.U.E.*) | ----- |
| U/G Fiber Optics Cable LOS C (S.U.E.*) | ----- |
| U/G Fiber Optics Cable LOS D (S.U.E.*) | ----- |

WATER:

| | |
|---------------------------------------|-------|
| Water Manhole | Ⓜ |
| Water Meter | Ⓜ |
| Water Valve | ⊗ |
| Water Hydrant | ⊕ |
| U/G Water Line LOS B (S.U.E.*) | ----- |
| U/G Water Line LOS C (S.U.E.*) | ----- |
| U/G Water Line LOS D (S.U.E.*) | ----- |
| Above Ground Water Line | ----- |
| TV: | |
| TV Pedestal | Ⓜ |
| TV Tower | ⊗ |
| U/G TV Cable Hand Hole | Ⓜ |
| U/G TV Cable LOS B (S.U.E.*) | ----- |
| U/G TV Cable LOS C (S.U.E.*) | ----- |
| U/G TV Cable LOS D (S.U.E.*) | ----- |
| U/G Fiber Optic Cable LOS B (S.U.E.*) | ----- |
| U/G Fiber Optic Cable LOS C (S.U.E.*) | ----- |
| U/G Fiber Optic Cable LOS D (S.U.E.*) | ----- |

GAS:

| | |
|-------------------------------------|-------|
| Gas Valve | ◇ |
| Gas Meter | Ⓜ |
| U/G Gas Line LOS B (S.U.E.*) | ----- |
| U/G Gas Line LOS C (S.U.E.*) | ----- |
| U/G Gas Line LOS D (S.U.E.*) | ----- |
| Above Ground Gas Line | ----- |
| SANITARY SEWER: | |
| Sanitary Sewer Manhole | Ⓜ |
| Sanitary Sewer Cleanout | Ⓜ |
| U/G Sanitary Sewer Line | ----- |
| Above Ground Sanitary Sewer | ----- |
| SS Forced Main Line LOS B (S.U.E.*) | ----- |
| SS Forced Main Line LOS C (S.U.E.*) | ----- |
| SS Forced Main Line LOS D (S.U.E.*) | ----- |

MISCELLANEOUS:

| | |
|--|--------|
| Utility Pole | ● |
| Utility Pole with Base | ⊠ |
| Utility Located Object | ○ |
| Utility Traffic Signal Box | Ⓜ |
| Utility Unknown U/G Line LOS B (S.U.E.*) | ----- |
| U/G Tank; Water, Gas, Oil | Ⓜ |
| Underground Storage Tank, Approx. Loc. | Ⓜ |
| A/G Tank; Water, Gas, Oil | Ⓜ |
| Geoenvironmental Boring | ⊕ |
| U/G Test Hole LOS A (S.U.E.*) | ⊕ |
| Abandoned According to Utility Records | AATUR |
| End of Information | E.O.I. |

8/17/99

PAVEMENT SCHEDULE

| | |
|----|--|
| C1 | PROP. APPROX. 3.0" ASPHALT CONCRETE SURFACE COURSE, TYPE S9.5B, AT AN AVERAGE RATE OF 168 Lbs PER SQUARE YARD IN EACH OF TWO LAYERS. |
| D1 | PROP. APPROX. 2.5" ASPHALT CONCRETE INTERMEDIATE COURSE, TYPE I19.0B, AT AN AVERAGE RATE OF 285 Lbs PER SQUARE YARD. |
| E1 | PROP. APPROX. 4.0" ASPHALT CONCRETE BASE COURSE, TYPE B25.0B, AT AN AVERAGE RATE OF 456 Lbs PER SQUARE YARD. |
| T | EARTH MATERIAL |
| V | 8" INCIDENTAL STONE BASE |

NOTE: PAVEMENT EDGE SLOPES ARE 1:1 UNLESS OTHERWISE SHOWN.

| | |
|---|----------------|
| PROJECT REFERENCE NO. 17BP.10.R.67 | SHEET NO. 2 |
| RW SHEET NO. | |
| ROADWAY DESIGN ENGINEER | |
| | |
| Designed by: | |
| DOCUMENT NOT CONSIDERED FINAL UNLESS ALL SIGNATURES COMPLETED | |
| HDR Engineering, Inc. of the Carolinas 555 Fayetteville St. Suite 900 Raleigh, N.C. 27601 N.C.B.E.L.S. License Number: F-0116 | |

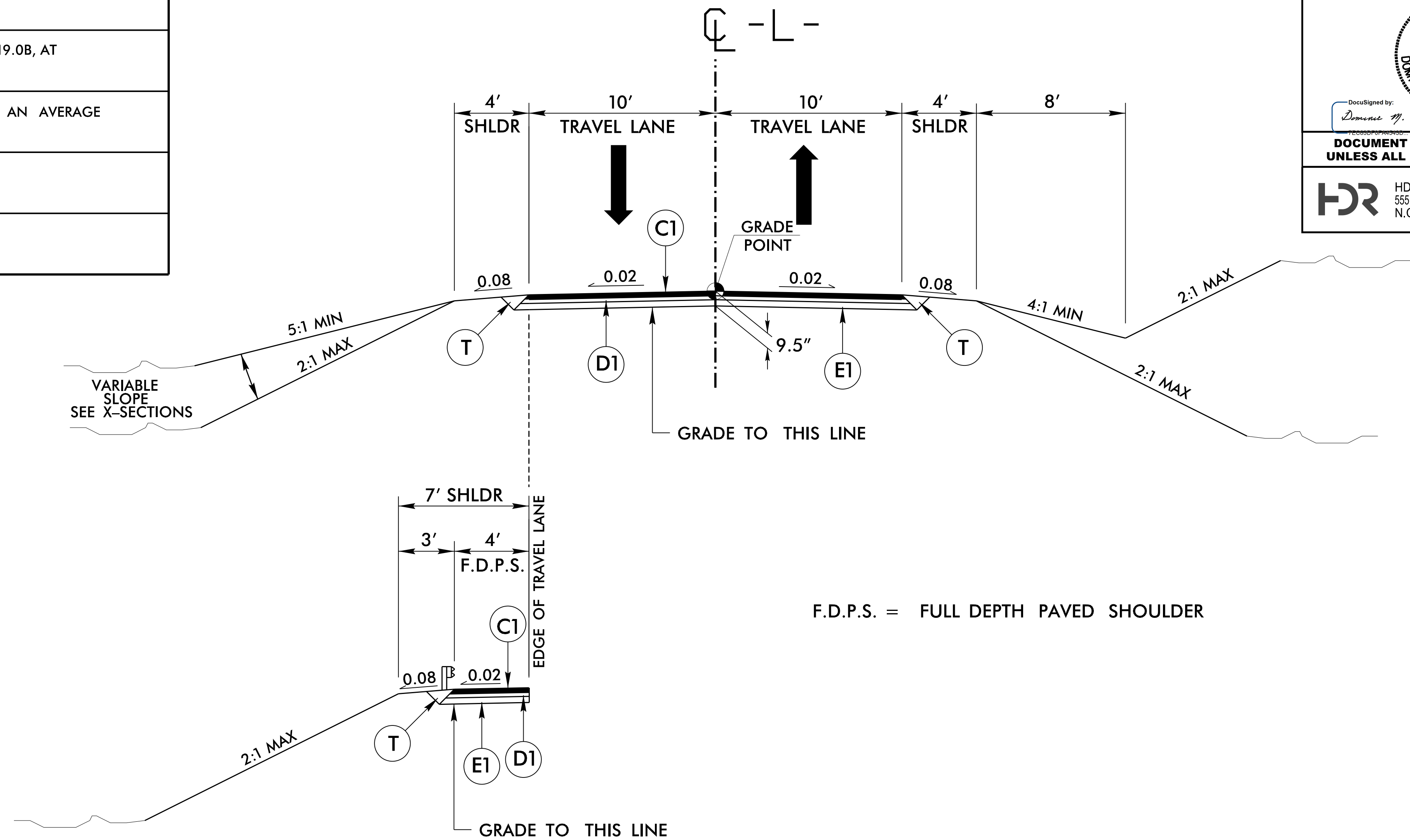

F.D.P.S. = FULL DEPTH PAVED SHOULDER

TYPICAL SECTION NO. 1

| LINE | FROM STATION | TO STATION |
|------|--------------|------------|
| -L- | 10 + 90.00 | 16 + 00.00 |

NOTE: PAVE DRIVEWAYS AT -L- STA. 13+79 RT AND 14+00 LT WITH (V) BEYOND FULL DEPTH PAVED SHOULDER LIMITS.

REVISIONS

3/29/2017
 17BP-10R67_RDY_TYP.DGN
 3:55:17 PM

| | |
|---|------------------|
| PROJECT REFERENCE NO. 17BP.10.R.67 | SHEET NO. 2-A |
| RW SHEET NO. | |
| HYDRAULICS ENGINEER | |
| | |
| DOCUMENT NOT CONSIDERED FINAL UNLESS ALL SIGNATURES COMPLETED | |
| HDR Engineering, Inc. of the Carolinas 555 Fayetteville St. Suite 900 Raleigh, N.C. 27601 N.C.B.E.L.S. License Number: F-0116 | |

*NATIVE MATERIAL CONSISTS OF MATERIAL THAT IS EXCAVATED FROM THE STREAM BED OR FLOODPLAIN AT THE PROJECT SITE DURING CULVERT INSTALLATION. RIP RAP MAY BE USED TO SUPPLEMENT THE NATIVE MATERIAL IN THE HIGH FLOW CULVERT BARREL(S). IF RIP RAP IS USED TO LINE THE HIGH FLOW CULVERT BARREL(S), NATIVE MATERIAL SHOULD BE PLACED ON TOP TO FILL VOIDS AND PROVIDE A FLAT SURFACE FOR ANIMAL PASSAGE. NATIVE MATERIAL IS SUBJECT TO APPROVAL BY THE ENGINEER AND MAY BE SUBJECT TO PERMIT CONDITIONS.

***NOTES:**

- 1) FLOOD PLAIN BENCH SHOULD BE CONSTRUCTED WITH NATIVE BED MATERIAL. CONSTRUCT BENCH TO THE TOP OF THE SILL AND LINE BENCH WITH COIR FIBER MATTING.
- 2) PLACE CLASS 'II' RIP RAP ON FACE OF FLOOD PLAIN BENCH AND CHANNEL SIDE SLOPES.

DETAIL
*NOT TO SCALE
**MULTI-BARREL – GENERAL
DETAIL LOW FLOW CHANNEL
AND FLOOD PLAIN SILL**

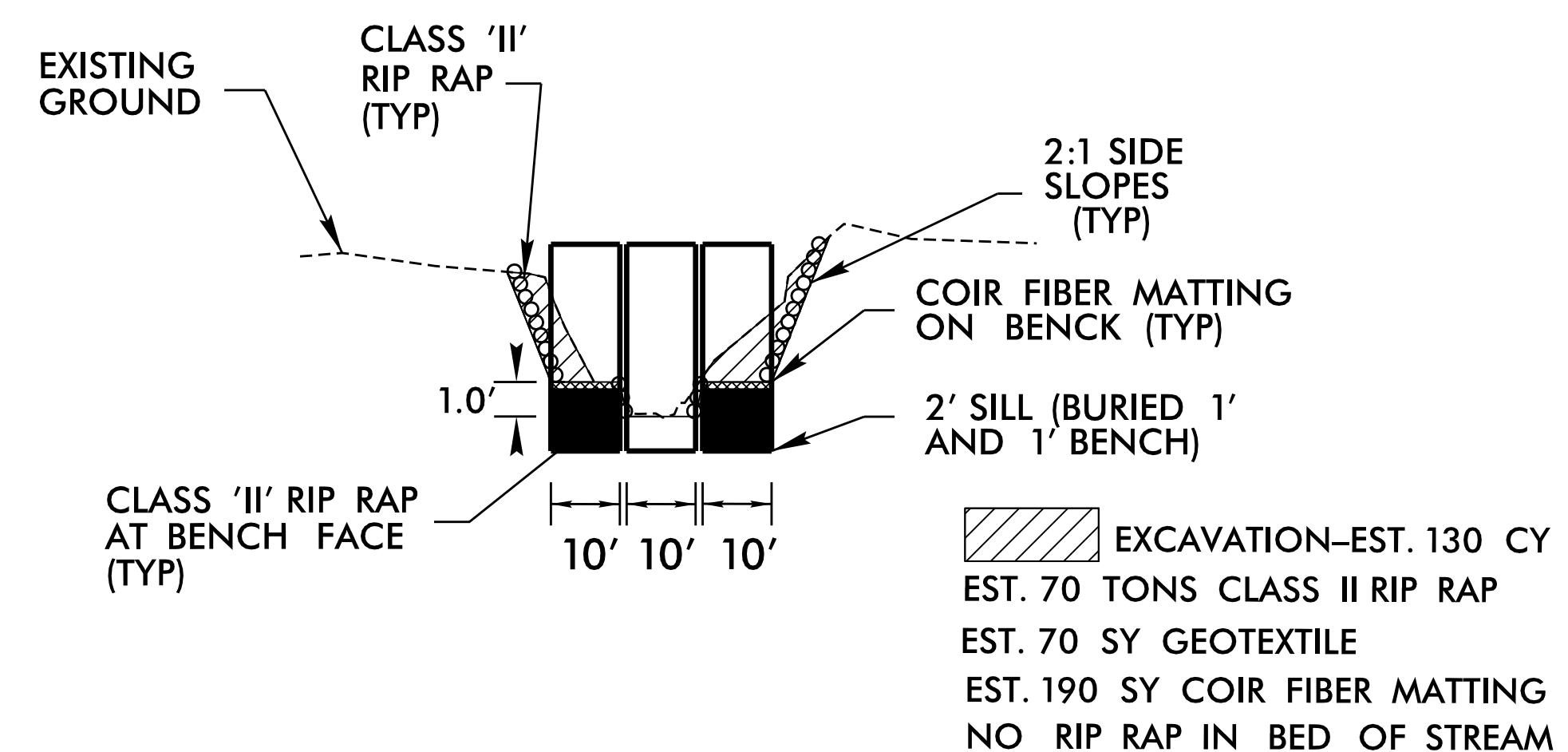
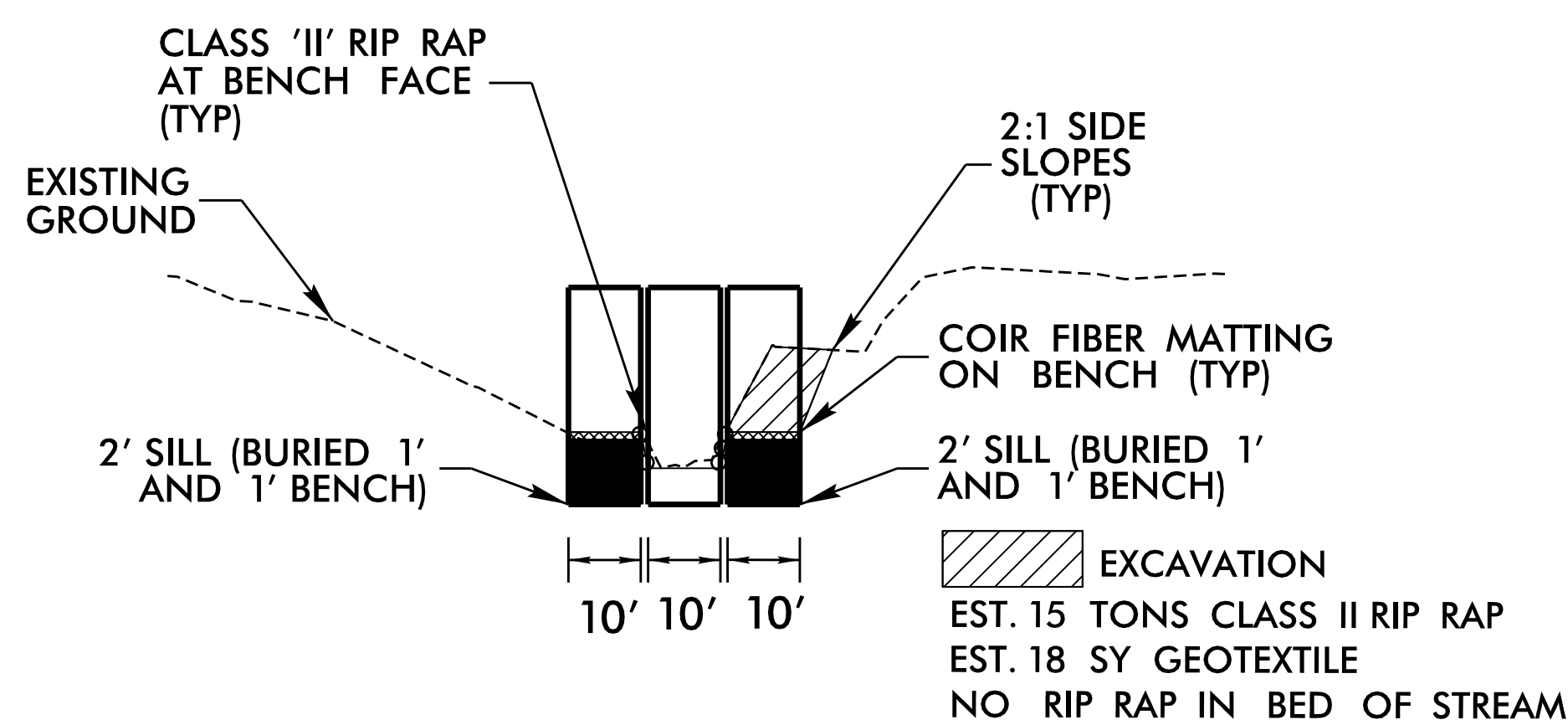
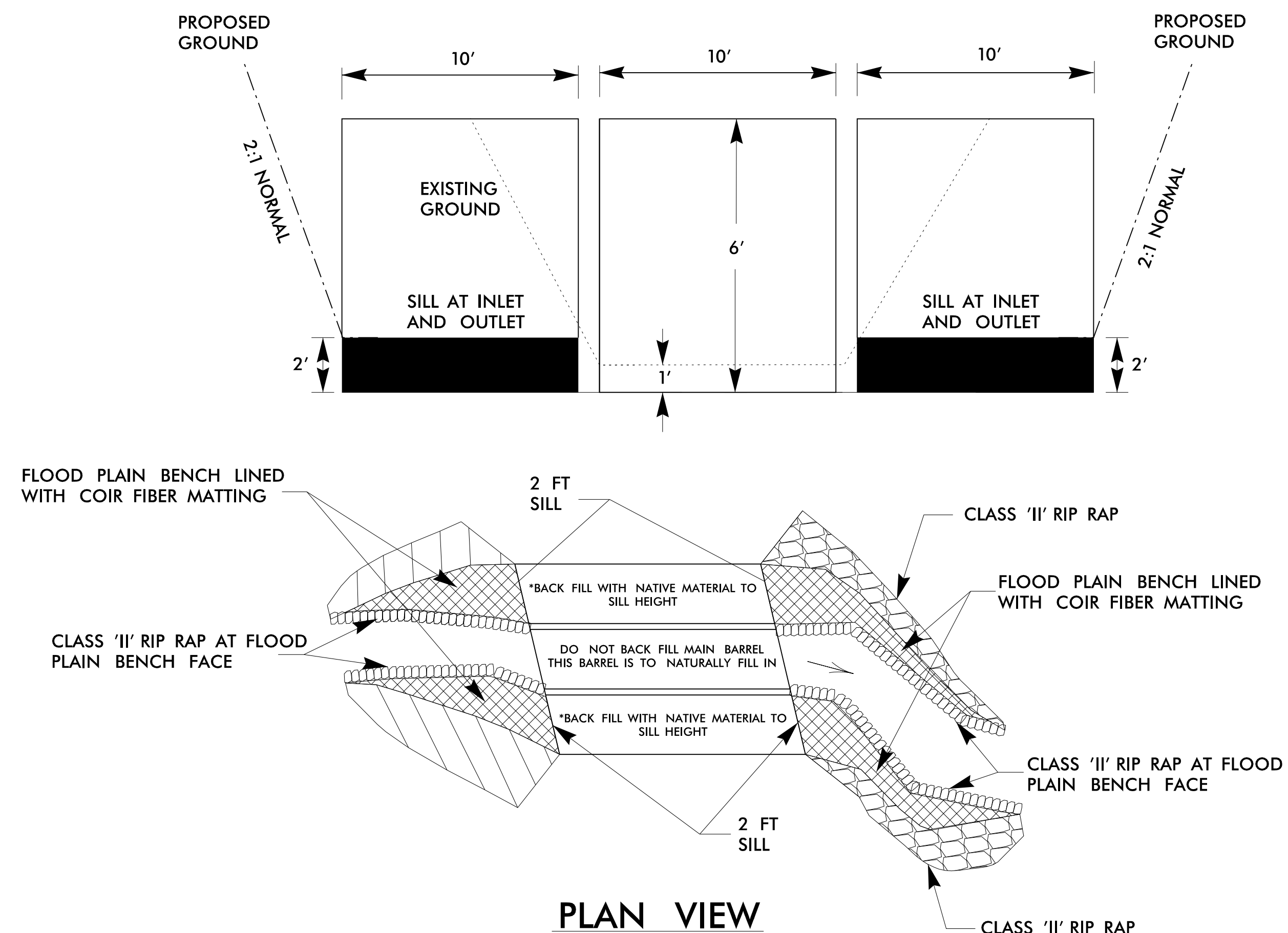

DATUM DESCRIPTION

THE LOCALIZED COORDINATE SYSTEM DEVELOPED FOR THIS PROJECT IS BASED ON THE STATE PLANE COORDINATES ESTABLISHED BY NCOS FOR MONUMENT "BL-1" WITH NAD 83/NA 2011 STATE PLANE GRID COORDINATES OF NORTHING: 502415.716(ft) EASTING: 155257.652(ft) ELEVATION: 536.76(ft)
 THE AVERAGE COMBINED GRID FACTOR USED ON THIS PROJECT (GROUND TO GRID) IS: 0.99985363
 THE N.C. LAMBERT GRID BEARING AND LOCALIZED HORIZONTAL GROUND DISTANCE FROM "BL-1" TO -L- STATION 10+90.00 IS S 81°32'50.52" W 103.84'
 ALL LINEAR DIMENSIONS ARE LOCALIZED HORIZONTAL DISTANCES VERTICAL DATUM USED IS NAVD 88

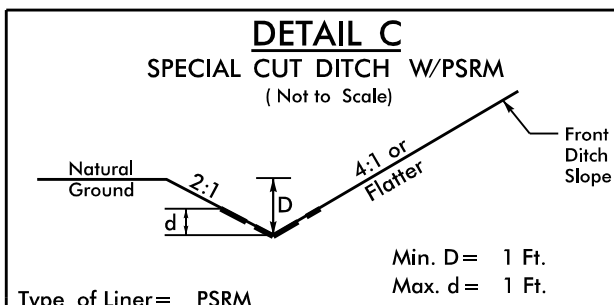
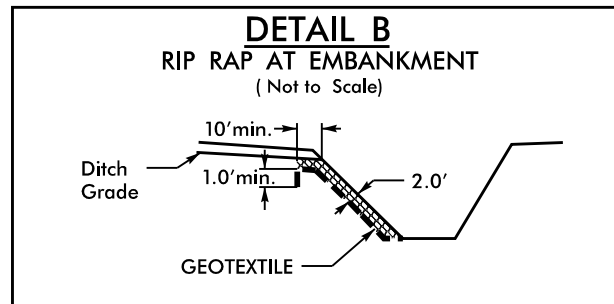
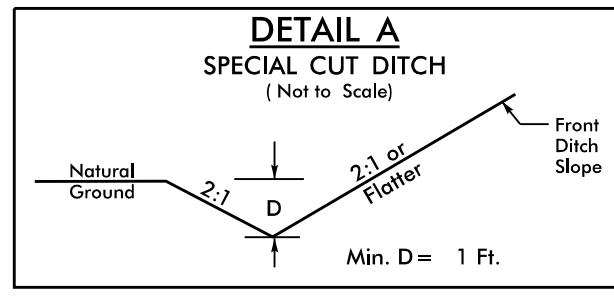

-L-
 PI Sta 12+52.78
 $\Delta = 9' 29' 34.6''$ (RT)
 $D = 3' 06' 50.0''$
 $L = 304.86'$
 $T = 152.78'$
 $R = 1,840.00'$
 $V = 45$ MPH
 $e = 0.04$

| BL | POINT | DESC. | NORTH | EAST | ELEVATION | EL. STATION | OFFSET |
|----|-------|-------|-------------|--------------|-----------|------------------------|----------|
| 1 | 4017 | | 502415.7160 | 155257.6520 | 536.76 | 11+05.02 | 14.22 LT |
| 3 | 4020 | | 502340.0198 | 1552973.0252 | 541.07 | 15+25.62 | 13.97 RT |
| 2 | 4017 | | 502268.2400 | 1553424.7260 | 563.155 | OUTSIDE PROJECT LIMITS | |

| | |
|---|-----------------------|
| PROJECT REFERENCE NO. 17BP10.R.67 | SHEET NO. 4 |
| RW SHEET NO. | HYDRAULICS ENGINEER |
| ROADWAY DESIGN ENGINEER | ENGINEER |
| | |
| 8/1/2017 | 8/1/2017 |

DOCUMENT NOT CONSIDERED FINAL UNLESS ALL SIGNATURES COMPLETED

HDR HDR Engineering, Inc. of the Carolinas
 555 Fayetteville St. Suite 900 Raleigh, N.C. 27601
 N.C.B.E.L.S. License Number: F-0116

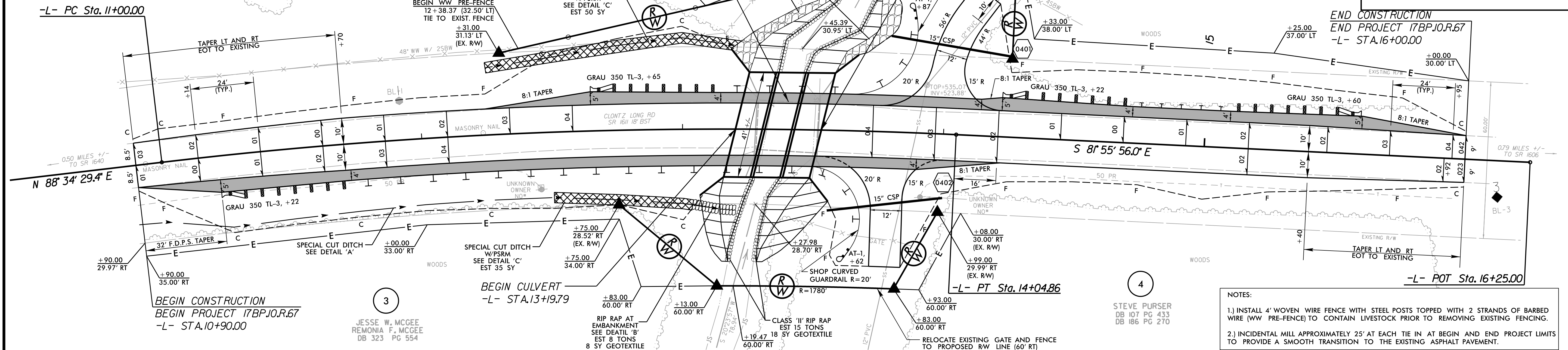

- NOTES:
- 1.) INSTALL 4' WOVEN WIRE FENCE WITH STEEL POSTS TOPPED WITH 2 STRANDS OF BARBED WIRE (WW PRE-FENCE) TO CONTAIN LIVESTOCK PRIOR TO REMOVING EXISTING FENCING.
 - 2.) INCIDENTAL MILL APPROXIMATELY 25' AT EACH TIE IN AT BEGIN AND END PROJECT LIMITS TO PROVIDE A SMOOTH TRANSITION TO THE EXISTING ASPHALT PAVEMENT.

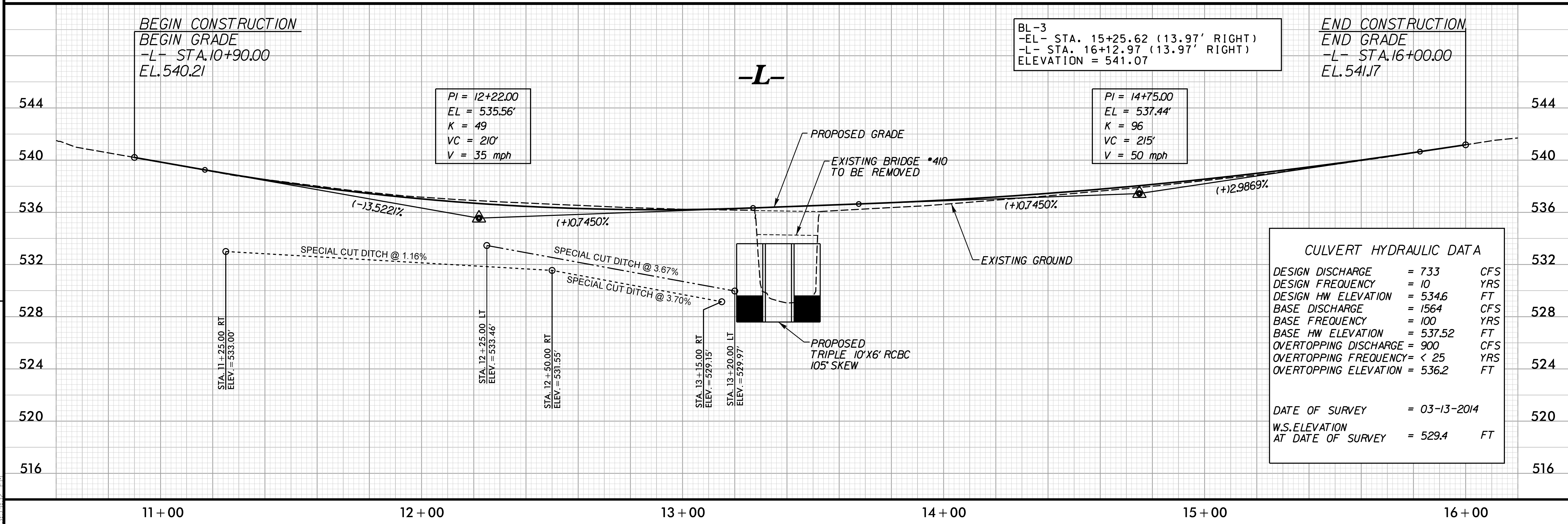

REVISIONS

3/29/2017
 10:53:32 PM
 17BP-10R67_ROY_PSH4.DGN

STATE OF NORTH CAROLINA
DIVISION OF HIGHWAYS

TRANSPORTATION MANAGEMENT PLAN

UNION COUNTY

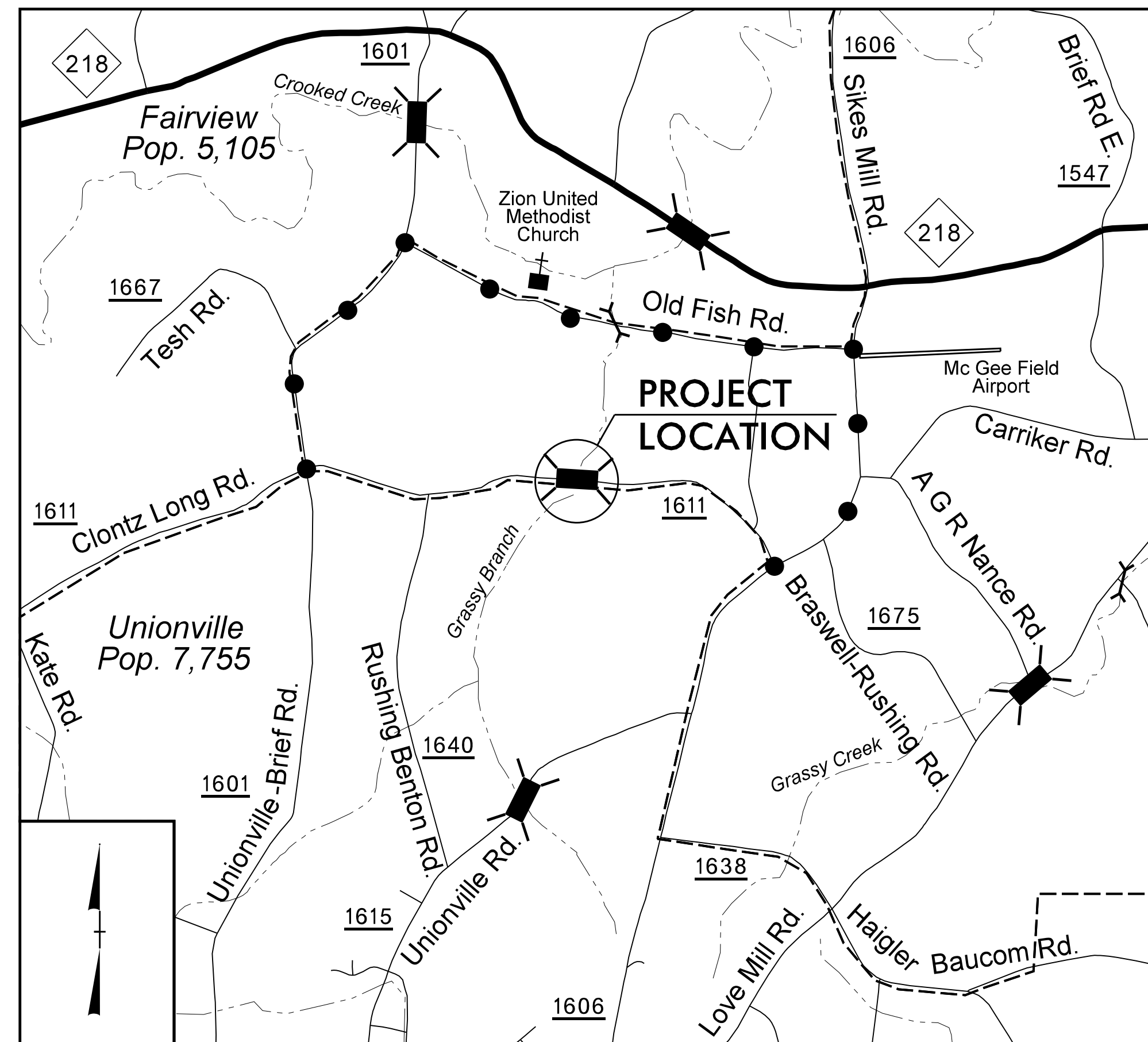
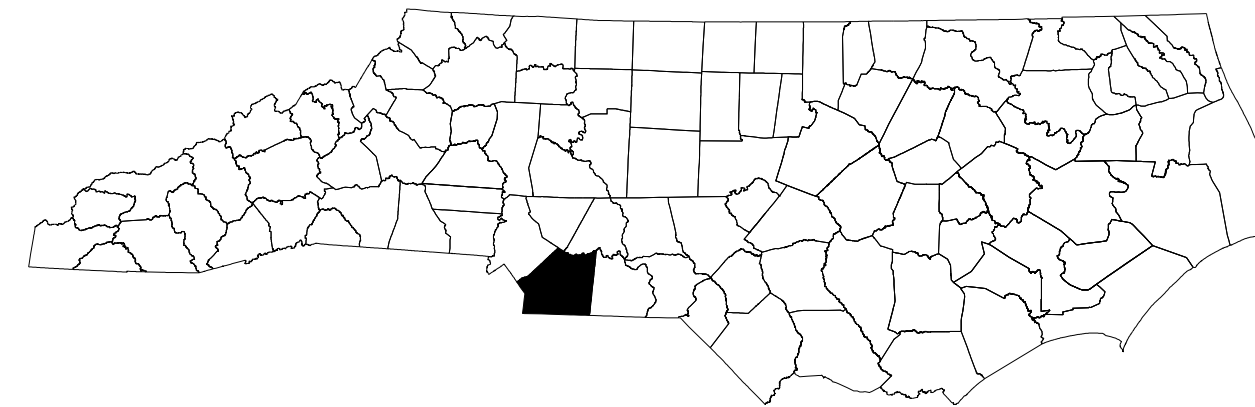

● — ●
DETOUR ROUTE

VICINITY MAP
(NOT TO SCALE)

PLOT DRIVER: NCDOT_paf_color_eng_50.plt
 USER: dwohwr1
 FILE: dw\WPAPP\PA01\SouthEast_Tampa_Documents\000166\CON0082236\00000000221869\06.00_TIP_Folder_Structure\17BP.10.R.67\TrafficControl\TCP\17BP-10R67_TCP_DSN.dgn
 PENTABLE: NCDOT_tcp.tbl
 DATE: 3/17/2017
 TIME: 11:59:21 AM

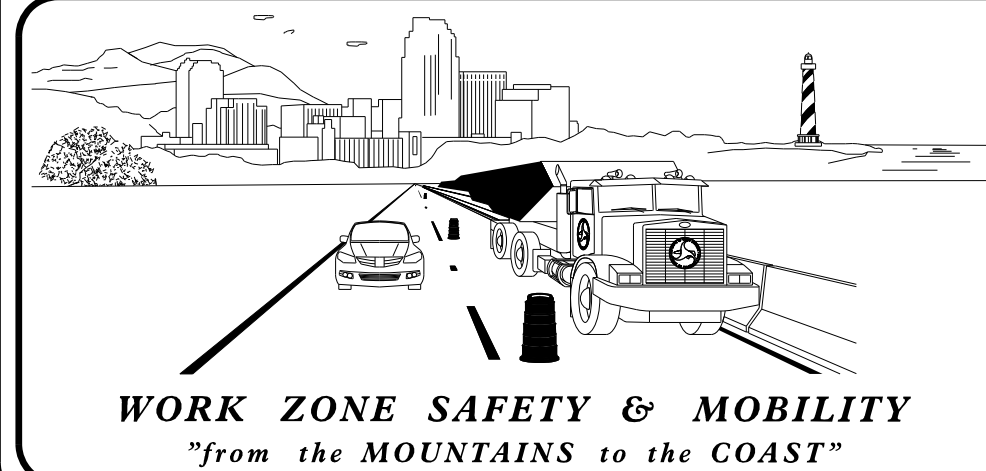

N.C.D.O.T. WORK ZONE TRAFFIC CONTROL
 1561 MAIL SERVICE CENTER (MSC) RALEIGH, NC 27699-1561
 750 N. GREENFIELD PARKWAY, GARNER, NC 27529 (DELIVERY)
 PHONE: (919) 773-2800 FAX: (919) 771-2745

J. S. BOURNE, P.E. STATE TRAFFIC MANAGEMENT ENGINEER
 DOMINIC WAINWRIGHT, P.E. ROADWAY PROJECT ENGINEER
 MICHELLE WARD, P.E. TRAFFIC CONTROL PROJECT DESIGN ENGINEER
 T. NATHAN BEDENBAUGH, P.E. TRAFFIC CONTROL DESIGN ENGINEER

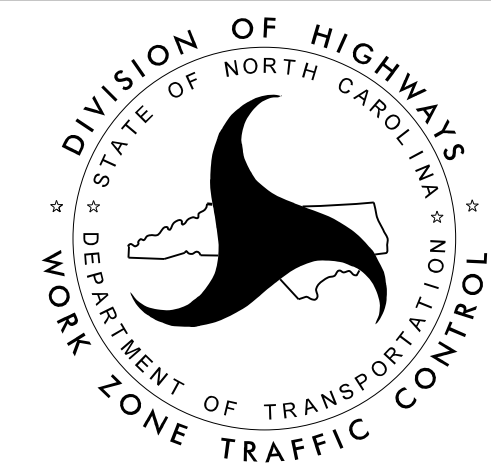

INDEX OF SHEETS

| SHEET NO. | TITLE |
|-----------|---|
| TMP-1 | TITLE SHEET AND INDEX OF SHEETS |
| TMP-1A | LIST OF APPLICABLE ROADWAY STANDARD DRAWINGS AND LEGEND |
| TMP-1B | GENERAL NOTES AND PHASING |
| TMP-2 | OFFSITE DETOUR PLAN - CLONTZ LONG ROAD (SR 1611) |
| SD-01 | SIGN DESIGN - CLONTZ LONG ROAD |

SHEET NO.
TMP-1

STATE PROJECT: 17BP.10.R.67

STATE PROJECT: 17BP.10.R.67

DOCUMENT NOT CONSIDERED FINAL
UNLESS ALL SIGNATURES COMPLETED

PLAN PREPARED BY:
HDR HDR Engineering, Inc. of the Carolinas
555 Fayetteville St, Suite 900, Raleigh, N.C. 27601
N.C.B.E.L.S. License Number: F-0116

APPROVED: *Michelle Ward*
 DATE: 8/1/2017
 SEAL





ROADWAY STANDARD DRAWINGS

THE FOLLOWING ROADWAY STANDARDS AS SHOWN IN "ROADWAY STANDARD DRAWINGS" - PROJECT SERVICES UNIT - N.C. DEPARTMENT OF TRANSPORTATION - RALEIGH, N.C., DATED JANUARY 2012 ARE APPLICABLE TO THIS PROJECT AND BY REFERENCE HEREBY ARE CONSIDERED A PART OF THESE PLANS:





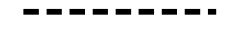
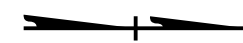

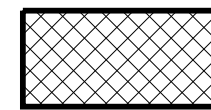



| STD. NO. | TITLE |
|----------|--|
| 1101.01 | WORK ZONE WARNING SIGNS |
| 1101.03 | TEMPORARY ROAD CLOSURES |
| 1101.11 | TRAFFIC CONTROL DESIGN TABLES |
| 1110.01 | STATIONARY WORK ZONE SIGNS |
| 1145.01 | BARRICADES |
| 1261.01 | GUARDRAIL AND BARRIER DELINEATORS - INSTALLATION SPACING |
| 1261.02 | GUARDRAIL AND BARRIER DELINEATORS - TYPES AND MOUNTING |
| 1262.01 | GUARDRAIL END DELINEATION |

LEGEND

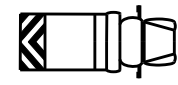

GENERAL

-  DIRECTION OF TRAFFIC FLOW
-  DIRECTION OF PEDESTRIAN TRAFFIC FLOW
-  EXIST. PVMT.
-  NORTH ARROW
-  PROPOSED PVMT.
-  WORK AREA
-  REMOVAL

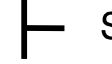

TRAFFIC CONTROL DEVICES

-  BARRICADE (TYPE III)
-  CONE
-  DRUM
-  SKINNY DRUM
-  TUBULAR MARKER
-  TEMPORARY CRASH CUSHION
-  FLASHING ARROW PANEL (TYPE C)
-  FLAGGER
-  LAW ENFORCEMENT
-  TRUCK MOUNTED IMPACT ATTENUATOR (TMIA)
-  CHANGEABLE MESSAGE SIGN

TEMPORARY SIGNING

-  PORTABLE SIGN
-  STATIONARY SIGN
-  STATIONARY OR PORTABLE SIGN

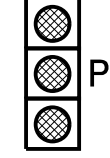

SIGNALS

-  EXISTING
-  PROPOSED
-  TEMPORARY

PAVEMENT MARKINGS

-  EXISTING LINES
-  TEMPORARY LINES

PAVEMENT MARKERS

-  CRYSTAL/CRYSTAL
-  CRYSTAL/RED
-  YELLOW/YELLOW

PAVEMENT MARKING SYMBOLS

-  PAVEMENT MARKING SYMBOLS

PLOT DRIVER: NCD0T_paf_color_eng_50.plt
 USER: dwohwr1
 FILE: dw\WPAPPTPA01\SouthEast_Tampa\Documents\000166\CON0082236\00000000221869\06.00_TIP_Folder_Structure\17BP.10.R.67\TrafficControl\TCP\17BP.10R67.TCP.DSN.dgn
 PENTABLE: NCD0T_tcp.tbl
 TIME: 11:59:22 AM
 DATE: 3/17/2017

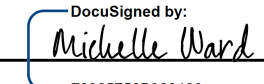
APPROVED: 
DocuSigned by: Michelle Ward
F33857508920486

DATE: 8/1/2017

SEAL

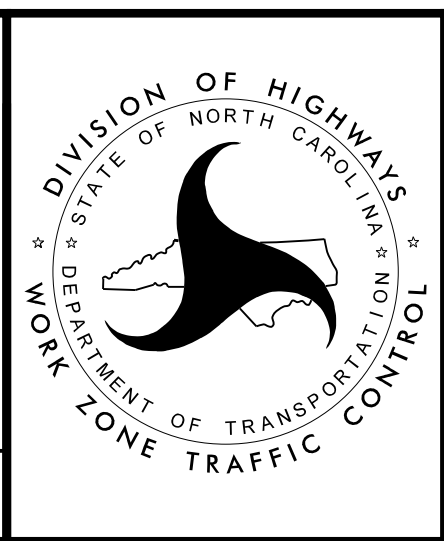
ROADWAY STANDARD
DRAWINGS & LEGEND

**DOCUMENT NOT CONSIDERED FINAL
UNLESS ALL SIGNATURES COMPLETED**

GENERAL NOTES

CHANGES MAY BE REQUIRED WHEN PHYSICAL DIMENSIONS IN THE DETAIL DRAWINGS, STANDARD DETAILS, AND ROADWAY DETAILS ARE NOT ATTAINABLE TO MEET FIELD CONDITIONS, OR RESULT IN DUPLICATE, OR UNDESIRED OVERLAPPING OR DEVICES. MODIFICATION MAY INCLUDE: MOVING, SUPPLEMENTING, COVERING, OR REMOVAL OF DEVICES, AS DIRECTED BY THE ENGINEER.

THE FOLLOWING GENERAL NOTES APPLY AT ALL TIMES FOR THE DURATION OF THE CONSTRUCTION PROJECT, EXCEPT WHEN OTHERWISE NOTED IN THE PLAN, OR DIRECTED BY THE ENGINEER.

TRAFFIC PATTERN ALTERATIONS

- A) NOTIFY THE ENGINEER TWENTY ONE (21) CALENDAR DAYS PRIOR TO ANY TRAFFIC PATTERN ALTERATION.

SIGNING

- B) INSTALL ADVANCE WORK ZONE WARNING SIGNS WHEN WORK IS WITHIN 40 FT FROM THE EDGE OF TRAVEL LANE AND NO MORE THAN THREE (3) DAYS PRIOR TO THE BEGINNING OF CONSTRUCTION.

- C) PROVIDE SIGNING AND DEVICES REQUIRED TO CLOSE THE ROAD ACCORDING TO THE ROADWAY STANDARD DRAWINGS AND TRAFFIC CONTROL PLANS.

PROVIDE SIGNING REQUIRED FOR THE OFFSITE DETOUR ROUTE AS SHOWN IN THE TRAFFIC CONTROL PLANS.

- D) COVER OR REMOVE ALL SIGNS AND DEVICES REQUIRED TO CLOSE THE ROAD WHEN THE ROAD CLOSURE IS NOT IN OPERATION.

COVER OR REMOVE ALL SIGNS REQUIRED FOR THE OFFSITE DETOUR WHEN THE DETOUR IS NOT IN OPERATION.

- E) ENSURE ALL NECESSARY SIGNING IS IN PLACE PRIOR TO ALTERING ANY TRAFFIC PATTERN.

TRAFFIC CONTROL DEVICES

- F) PLACE TYPE III BARRICADES, WITH "ROAD CLOSED" SIGN R11-2 ATTACHED, OF SUFFICIENT LENGTH TO CLOSE ENTIRE ROADWAY.

PAVEMENT MARKINGS AND MARKERS

- G) STATE FORCES WILL INSTALL PAVEMENT MARKINGS AND PAVEMENT MARKERS ON THE FINAL SURFACE.

PHASING

TRAFFIC CONTROL PHASING

NOTE: COORDINATE WITH THE ENGINEER FOR INSTALLATION AND REMOVAL OF ALL SIGNING AND TRAFFIC CONTROL DEVICES.

NOTE: MAINTAIN ACCESS TO DRIVEWAYS WITHIN PROJECT LIMITS AT ALL TIMES.

STEP 1: USING RSD 1101.01, SHEET 3 OF 3, INSTALL ADVANCE WORK ZONE WARNING SIGNS ON CLONTZ LONG ROAD (SR 1611).



STEP 2: USING RSD 1101.03, SHEET 1 OF 9 AND SHEET TMP-2, INSTALL DETOUR SIGNS AND BARRICADES AND CLOSE CLONTZ LONG ROAD (SR 1611).

STEP 3: REMOVE EXISTING BRIDGE NO. 410 AND CONSTRUCT PROPOSED BOX CULVERT AND ROADWAY, UP TO AND INCLUDING THE FINAL LAYER OF SURFACE COURSE. (NOTE: COORDINATE WITH STATE FORCES TO INSTALL FINAL PAVEMENT MARKINGS AND MARKERS ONCE CONSTRUCTION IS COMPLETE.)

STEP 4: REMOVE ALL ADVANCE WORK ZONE DETOUR SIGNS, AND TRAFFIC CONTROL DEVICES AND OPEN CLONTZ LONG ROAD (SR 1611) TO TRAFFIC.

| | |
|---|---------------------|
| PROJ. REFERENCE NO. 17BP.10.R.67 | SHEET NO. TMP-1B |
|  HDR Engineering, Inc. of the Carolinas 555 Fayetteville St. Suite 900 Raleigh, N.C. 27601 N.C.B.E.L.S. License Number: F-0116 | |

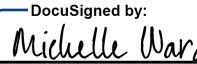
PLOT DRIVER: NCDOT_paf_color_eng_50.ppt PENTABLE: NCDOT_tcp.tbl DATE: 3/17/2017 TIME: 11:59:23 AM
 USER: dwohwr1 FILE: pw\WPAPPTPA01\SouthEast_Tampa\Documents\000166\CON0082236\000000000221869\06.00_TIP_Folder_Structure\17BP.10.R.67\TrafficControl\TCP\17BP-10R67_TCP_DSN.dgn

| | | | |
|---|---|---|------------------------------|
| APPROVED:  DATE: 8/1/2017 SEAL |  |  | GENERAL NOTES AND PHASING |
| DOCUMENT NOT CONSIDERED FINAL UNLESS ALL SIGNATURES COMPLETED | | | |

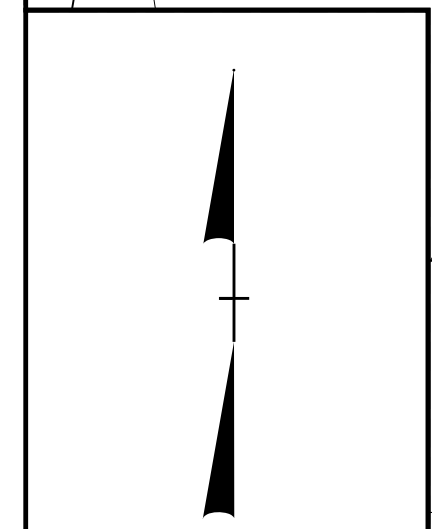
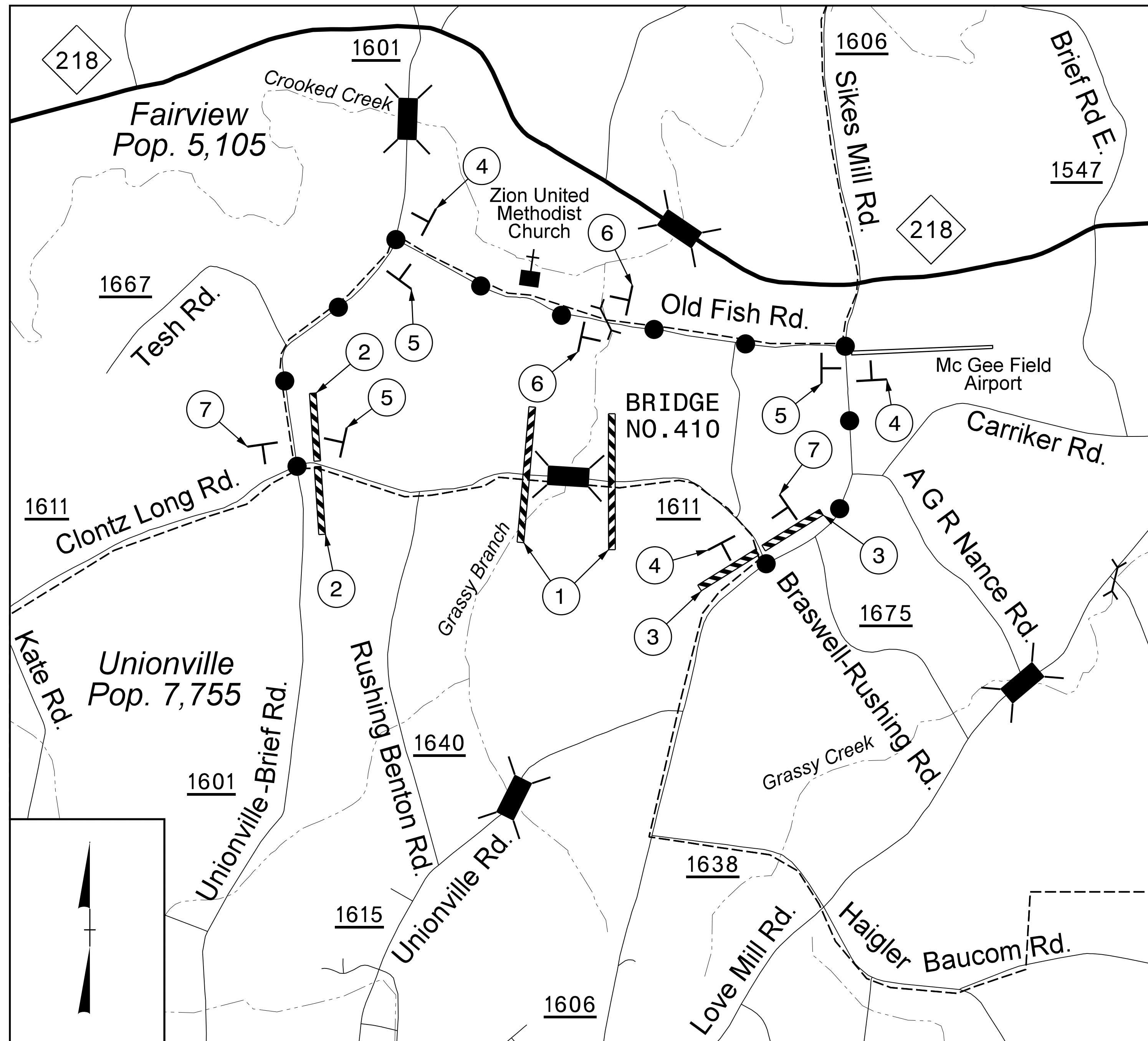

● — ●
DETOUR ROUTE

REFER TO RSD 1101.03 SHEET 1 OF 9 FOR
ADDITIONAL SIGN AND BARRICADE PLACEMENT

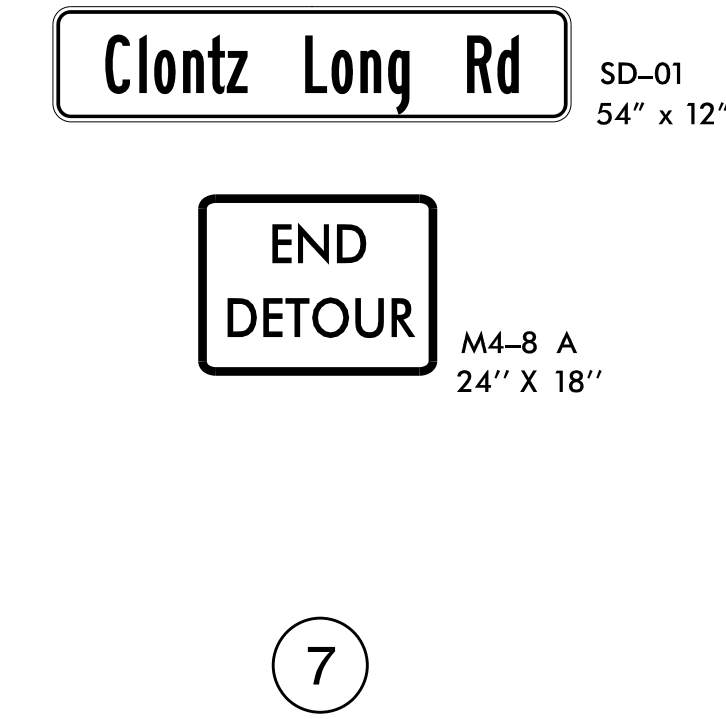
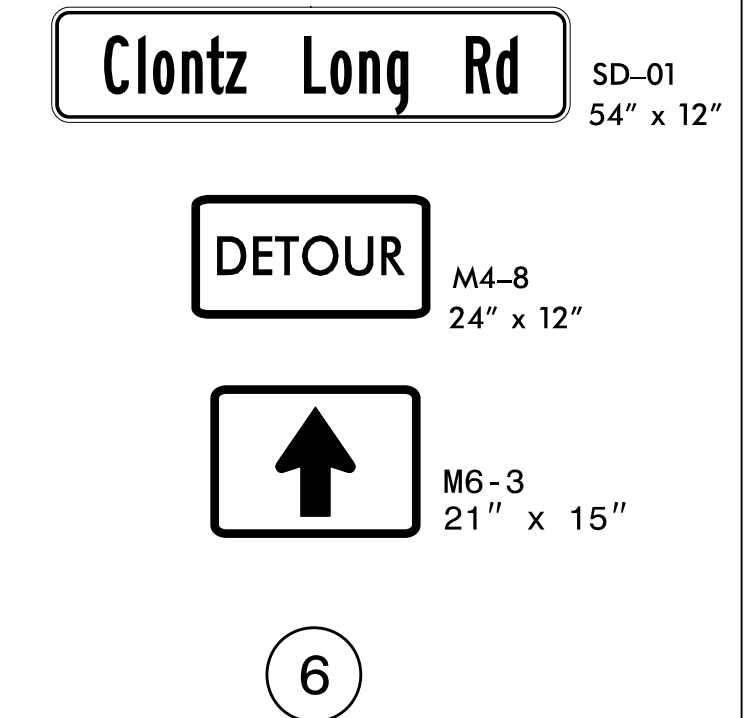
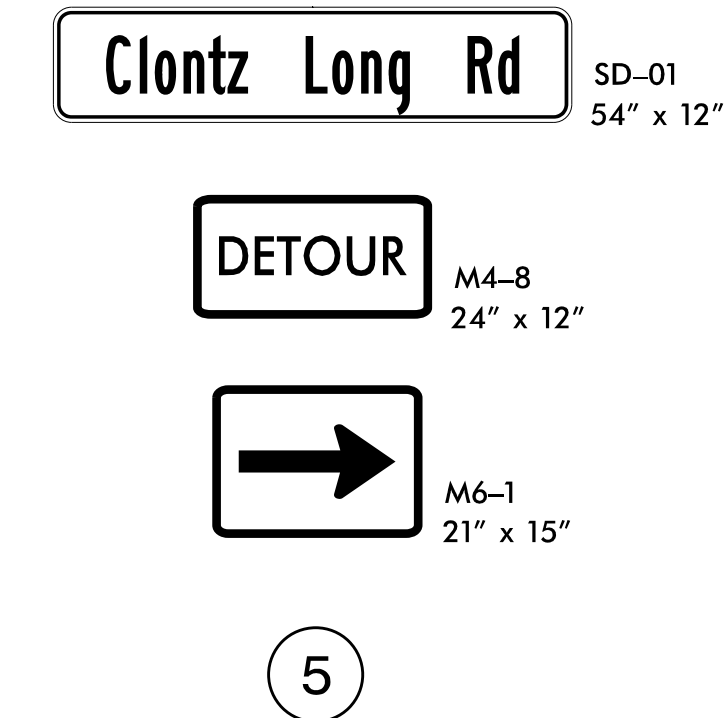
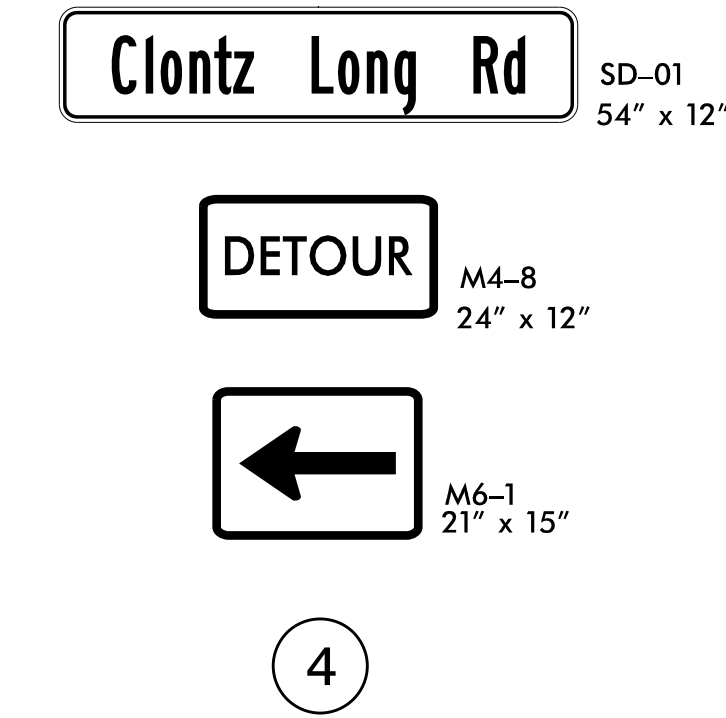
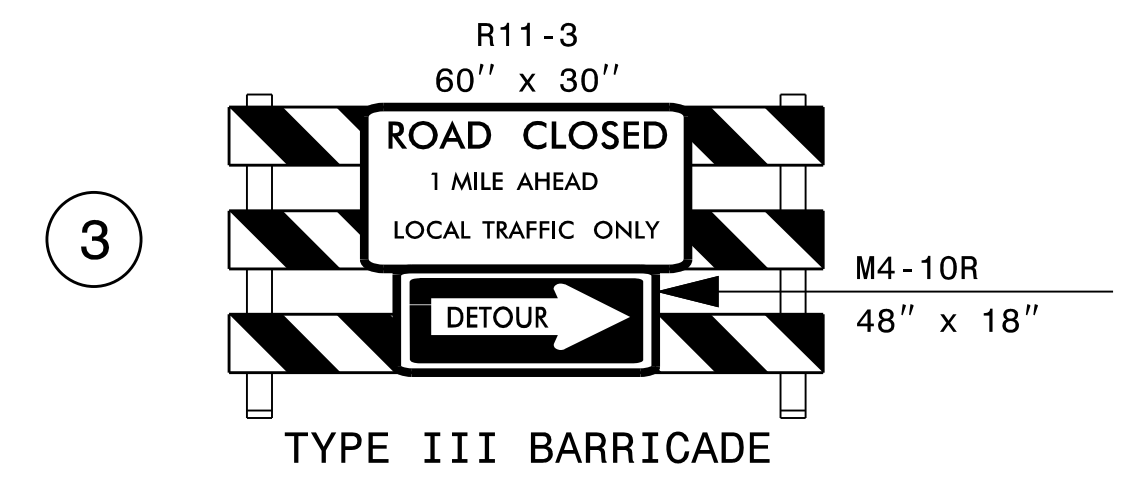
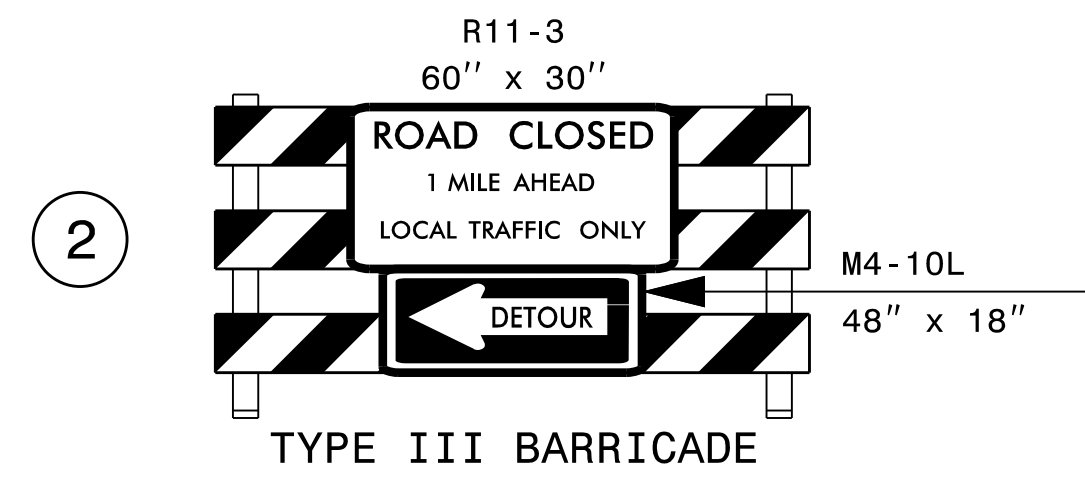
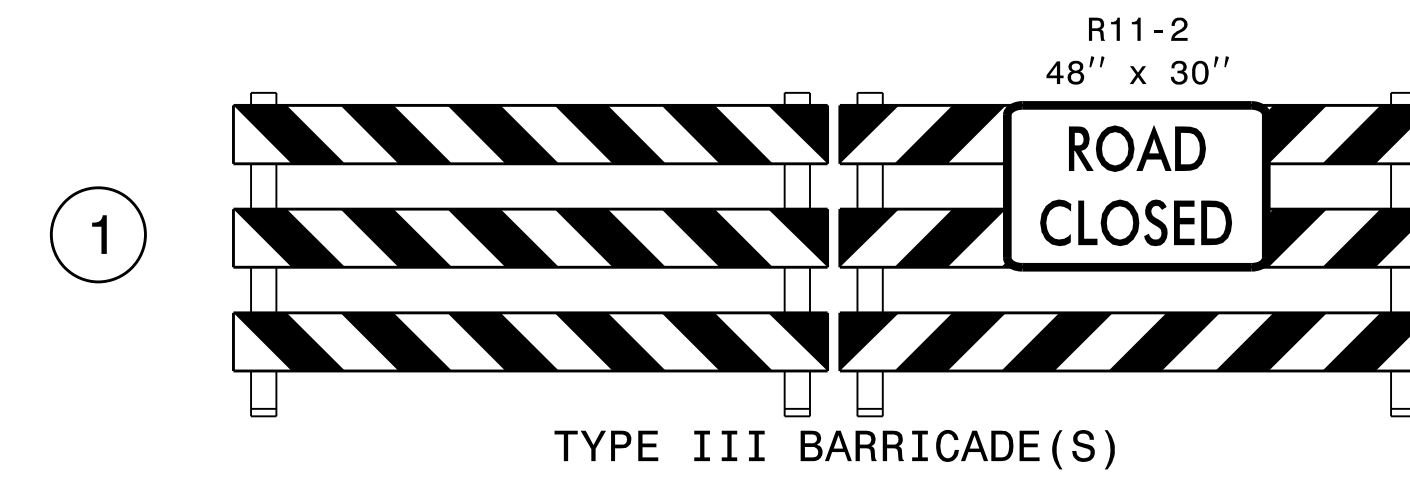

SEE SHEET SD-01 FOR SPECIAL SIGN DESIGN DETAIL

PLOT DRIVER: NCDOT_paf_color_eng_50.pit
 USER: dwohwr1
 FILE: pw\WPAPPTPA01\SouthEast_Tampa_Documents\000166\CON082236\00000000221869\06.00_TIP_Folder_Structure\17BP.10.R.67\TrafficControl\TCP\17BP-10R67_TCP_DSN.dgn
 PENTABLE: NCDOT_tcp.tbl
 TIME: 11:59:24 AM
 DATE: 3/17/2017

APPROVED: *Michelle Ward*
 DATE: 8/1/2017

SEAL

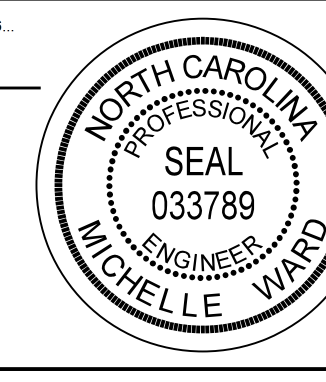

DOCUMENT NOT CONSIDERED FINAL
UNLESS ALL SIGNATURES COMPLETED

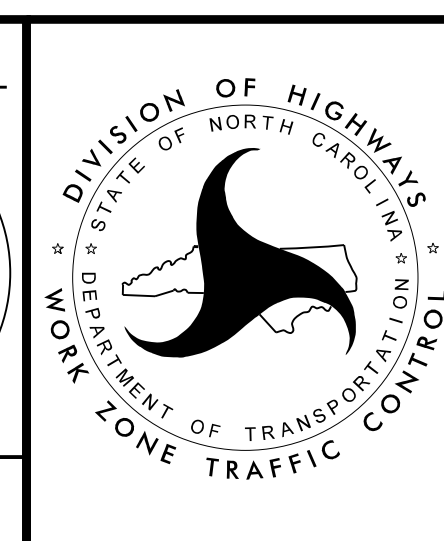

OFFSITE DETOUR PLAN
CLONTZ LONG ROAD
(SR 1611)

| SIGN NUMBER: TYPE: D QUANTITY: 1 SIGN WIDTH: 4'-6" HEIGHT: 1'-0" TOTAL AREA: 4.5 Sq.Ft. BORDER TYPE: FLUSH RECESS: 0.38" WIDTH: 0.38" RADII: 1.5" NO. Z BARS: LENGTH: | BACKG COLOR: Orange COPY COLOR: Black <table border="1"> <tr> <th>SYMBOL</th> <th>X</th> <th>Y</th> <th>WID</th> <th>HT</th> </tr> <tr><td> </td><td> </td><td> </td><td> </td><td> </td></tr> <tr><td> </td><td> </td><td> </td><td> </td><td> </td></tr> <tr><td> </td><td> </td><td> </td><td> </td><td> </td></tr> <tr><td> </td><td> </td><td> </td><td> </td><td> </td></tr> <tr><td> </td><td> </td><td> </td><td> </td><td> </td></tr> <tr><td> </td><td> </td><td> </td><td> </td><td> </td></tr> <tr><td> </td><td> </td><td> </td><td> </td><td> </td></tr> </table> MAT'L: 0.125" (3.2 mm) ALUMINUM | SYMBOL | X | Y | WID | HT | | | | | | | | | | | | | | | | | | | | | | | | | | | | | | | | | | | | DESIGN BY: D KERNS PROJECT ID: ID CHECKED BY: DIV: DIV DATE: Dec 18, 2013 |
|---|---|--|-----|----|-----|----|--|--|--|--|--|--|--|--|--|--|--|--|--|--|--|--|--|--|--|--|--|--|--|--|--|--|--|--|--|--|--|--|--|--|--|--|
| SYMBOL | X | Y | WID | HT | | | | | | | | | | | | | | | | | | | | | | | | | | | | | | | | | | | | | | |
| | | | | | | | | | | | | | | | | | | | | | | | | | | | | | | | | | | | | | | | | | | |
| | | | | | | | | | | | | | | | | | | | | | | | | | | | | | | | | | | | | | | | | | | |
| | | | | | | | | | | | | | | | | | | | | | | | | | | | | | | | | | | | | | | | | | | |
| | | | | | | | | | | | | | | | | | | | | | | | | | | | | | | | | | | | | | | | | | | |
| | | | | | | | | | | | | | | | | | | | | | | | | | | | | | | | | | | | | | | | | | | |
| | | | | | | | | | | | | | | | | | | | | | | | | | | | | | | | | | | | | | | | | | | |
| | | | | | | | | | | | | | | | | | | | | | | | | | | | | | | | | | | | | | | | | | | |
| USE NOTES: 1. Legend and border shall be direct applied non-reflective sheeting. 2. Background shall be Grade B reflective sheeting. | | <p>BORDER R=1.5" TH=0.38" IN=0.38"</p> | | | | | | | | | | | | | | | | | | | | | | | | | | | | | | | | | | | | | | | | |
| | | Spacing Factor is 1 unless specified otherwise | | | | | | | | | | | | | | | | | | | | | | | | | | | | | | | | | | | | | | | | |

LETTER POSITIONS

| Letter spacings are to start of next letter | | | | | | | | | | | | | | | | | Series/Size Text Length |
|---|-----|-----|-----|---|-----|---|-----|---|-----|---|-----|-----|---|-----|-----|-----|----------------------------|
| | C | l | o | n | t | z | | L | o | n | g | | R | d | | | B 2000 |
| | 5.5 | 3.5 | 1.6 | 3 | 2.6 | 2 | 2.2 | 6 | 2.8 | 3 | 2.9 | 2.2 | 6 | 3.2 | 2.2 | 5.5 | 43.1 |
| | | | | | | | | | | | | | | | | | |
| | | | | | | | | | | | | | | | | | |
| | | | | | | | | | | | | | | | | | |
| | | | | | | | | | | | | | | | | | |
| | | | | | | | | | | | | | | | | | |
| | | | | | | | | | | | | | | | | | |
| | | | | | | | | | | | | | | | | | |
| | | | | | | | | | | | | | | | | | |
| | | | | | | | | | | | | | | | | | |

FILENAME: DWSignDesigns

NORTH CAROLINA D.O.T. SIGN DETAIL

PLOT DRIVER: NCDOT_pdf_color_eng_50.plt
 USER: dwohwr1
 DATE: 3/17/2017
 TIME: 11:59:24 AM
 FILE: p:\PWPPTPA01\SouthEast_Tampa_Documents\000166\CON082236\00000000221869\06.00_TIP_Folder_Structure\17BP.10.R.67\TrafficControl\TCP\17BP.10R67.TCP.DSN.dgn

APPROVED:
 DATE: 8/1/2017
 SEAL

 DOCUMENT NOT CONSIDERED FINAL
 UNLESS ALL SIGNATURES COMPLETED

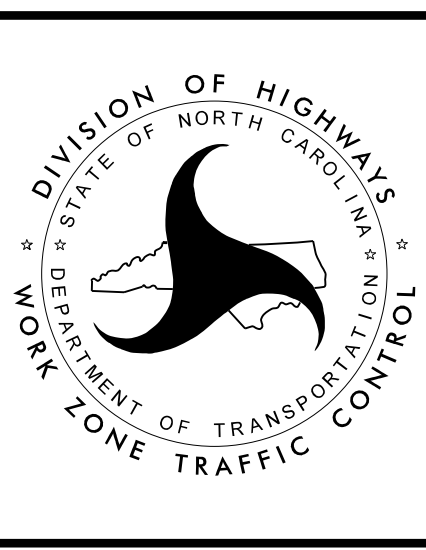

SIGN DESIGN
 CLONTZ LONG RD

STATE PROJECT: 17BP.10.R.67

HDR Engineering, Inc. of the Carolinas
555 Fayetteville St, Suite 900 Raleigh, N.C. 27601
N.C.B.E.L.S. License Number: F-0116

THESE EROSION AND SEDIMENT CONTROL PLANS COMPLY WITH THE REGULATIONS SET FORTH BY THE NCG-010000 GENERAL CONSTRUCTION PERMIT EFFECTIVE AUGUST 3, 2011 ISSUED BY THE NORTH CAROLINA DEPARTMENT OF ENVIRONMENT AND NATURAL RESOURCES DIVISION OF WATER QUALITY.

JOSHUA MASSROCK
LEVEL III NAME

3573
LEVEL IIIA CERTIFICATION NO.

STATE OF NORTH CAROLINA
DIVISION OF HIGHWAYS
PLAN FOR PROPOSED
HIGHWAY EROSION CONTROL
UNION COUNTY

LOCATION: BRIDGE NO. 410 ON SR 1611 OVER GRASSY BRANCH
BETWEEN SR 1640 AND SR 1606

TYPE OF WORK: GRADING, DRAINAGE, PAVING AND STRUCTURE

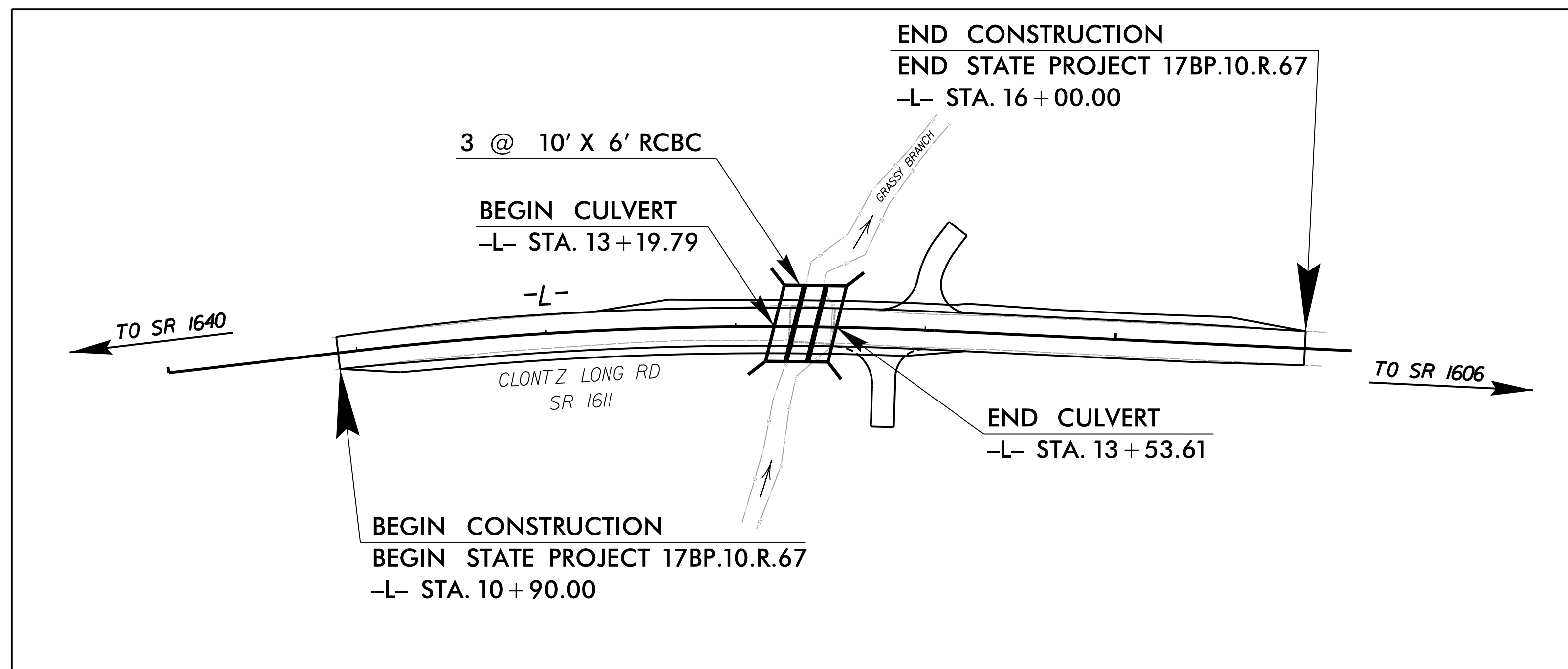
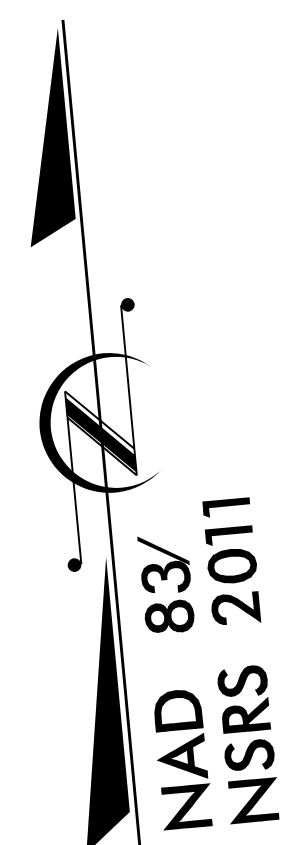

LOCATION SKETCH

CLEARING ON THIS PROJECT SHALL BE PERFORMED TO THE LIMITS ESTABLISHED BY METHOD II

GRAPHIC SCALE

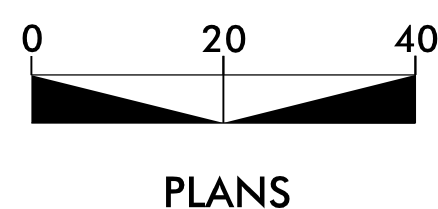

PLANS

ROADSIDE ENVIRONMENTAL UNIT
DIVISION OF HIGHWAYS
STATE OF NORTH CAROLINA

THESE EROSION AND SEDIMENT CONTROL PLANS COMPLY WITH THE REGULATIONS SET FORTH BY THE NCG-010000 GENERAL CONSTRUCTION PERMIT EFFECTIVE AUGUST 3, 2011 ISSUED BY THE NORTH CAROLINA DEPARTMENT OF ENVIRONMENT AND NATURAL RESOURCES DIVISION OF WATER QUALITY.

Prepared in the Office of:
ROADSIDE ENVIRONMENTAL UNIT
1 South Wilmington St.
Raleigh, NC 27611
2012 STANDARD SPECIFICATIONS

Roadway Standard Drawings

The following roadway english standards as appear in "Roadway Standard Drawings"- Roadway Design Unit - N. C. Department of Transportation - Raleigh, N. C., dated January 2012 and the latest revision thereto are applicable to this project and by reference hereby are considered a part of these plans.

- | | |
|--|--|
| 1604.01 Railroad Erosion Control Detail | 1632.01 Rock Inlet Sediment Trap Type A |
| 1605.01 Temporary Silt Fence | 1632.02 Rock Inlet Sediment Trap Type B |
| 1606.01 Special Sediment Control Fence | 1632.03 Rock Inlet Sediment Trap Type C |
| 1607.01 Gravel Construction Entrance | 1633.01 Temporary Rock Silt Check Type A |
| 1622.01 Temporary Berms and Slope Drains | 1633.02 Temporary Rock Silt Check Type B |
| 1630.01 Riser Basin | 1634.01 Temporary Rock Sediment Dam Type A |
| 1630.02 Silt Basin Type B | 1634.02 Temporary Rock Sediment Dam Type B |
| 1630.03 Temporary Silt Ditch | 1635.01 Rock Pipe Inlet Sediment Trap Type A |
| 1630.04 Stilling Basin | 1635.02 Rock Pipe Inlet Sediment Trap Type B |
| 1630.05 Temporary Diversion | 1640.01 Coir Fiber Baffle |
| 1630.06 Special Stilling Basin | 1645.01 Temporary Stream Crossing |
| 1631.01 Matting Installation | |

| | | | |
|-----------------|-----------------------------|--------------------|--------------|
| STATE | STATE PROJECT REFERENCE NO. | SHEET NO. | TOTAL SHEETS |
| N.C. | 17BP.10.R.67 | EC-1 | |
| STATE PROJ. NO. | F.A. PROJ. NO. | DESCRIPTION | |
| 17BP.10.R.67 | | P.E., R/W, CONSTR. | |
| | | | |
| | | | |

EROSION AND SEDIMENT CONTROL MEASURES

| Std. # | Description | Symbol |
|---------|--|------------------------|
| 1630.05 | Temporary Silt Ditch | TD |
| 1630.05 | Temporary Diversion | TD |
| 1605.01 | Temporary Silt Fence | III III III |
| 1606.01 | Special Sediment Control Fence | III III III |
| 1622.01 | Temporary Berms and Slope Drains | TSD |
| 1630.02 | Silt Basin Type B | Silt Basin |
| 1633.01 | Temporary Rock Silt Check Type-A | Rock Silt Check |
| | Temporary Rock Silt Check Type-A with Matting and Polyacrylamide (PAM) | Rock Silt Check |
| 1633.02 | Temporary Rock Silt Check Type-B | Rock Silt Check |
| | Wattle / Coir Fiber Wattle | Wattle |
| | Wattle / Coir Fiber Wattle with Polyacrylamide (PAM) | Wattle |
| 1634.01 | Temporary Rock Sediment Dam Type-A | Rock Sediment Dam |
| 1634.02 | Temporary Rock Sediment Dam Type-B | Rock Sediment Dam |
| 1635.01 | Rock Pipe Inlet Sediment Trap Type-A | Rock Pipe Inlet |
| 1635.02 | Rock Pipe Inlet Sediment Trap Type-B | Rock Pipe Inlet |
| 1630.04 | Stilling Basin | Stilling Basin |
| 1630.06 | Special Stilling Basin | Special Stilling Basin |
| | Rock Inlet Sediment Trap: | |
| 1632.01 | Type A | A |
| 1632.02 | Type B | B |
| 1632.03 | Type C | C |
| | Skimmer Basin | Skimmer Basin |
| | Tiered Skimmer Basin | Tiered Skimmer Basin |
| | Infiltration Basin | Infiltration Basin |

THIS PROJECT CONTAINS EROSION CONTROL PLANS FOR CLEARING AND GRUBBING PHASE OF CONSTRUCTION.

NOTES: ANY DEVIATION FROM OPTIONS GIVEN WILL REQUIRE PRIOR APPROVAL BY ENGINEER.

ADDITIONAL EROSION CONTROL DEVICES MAY NEED TO BE INSTALLED AS DIRECTED BY THE ENGINEER.

TEMPORARY ROCK SILT CHECK TYPE 'A' WITH EXCELSIOR MATTING AND POLYACRYLAMIDE (PAM) DETAIL

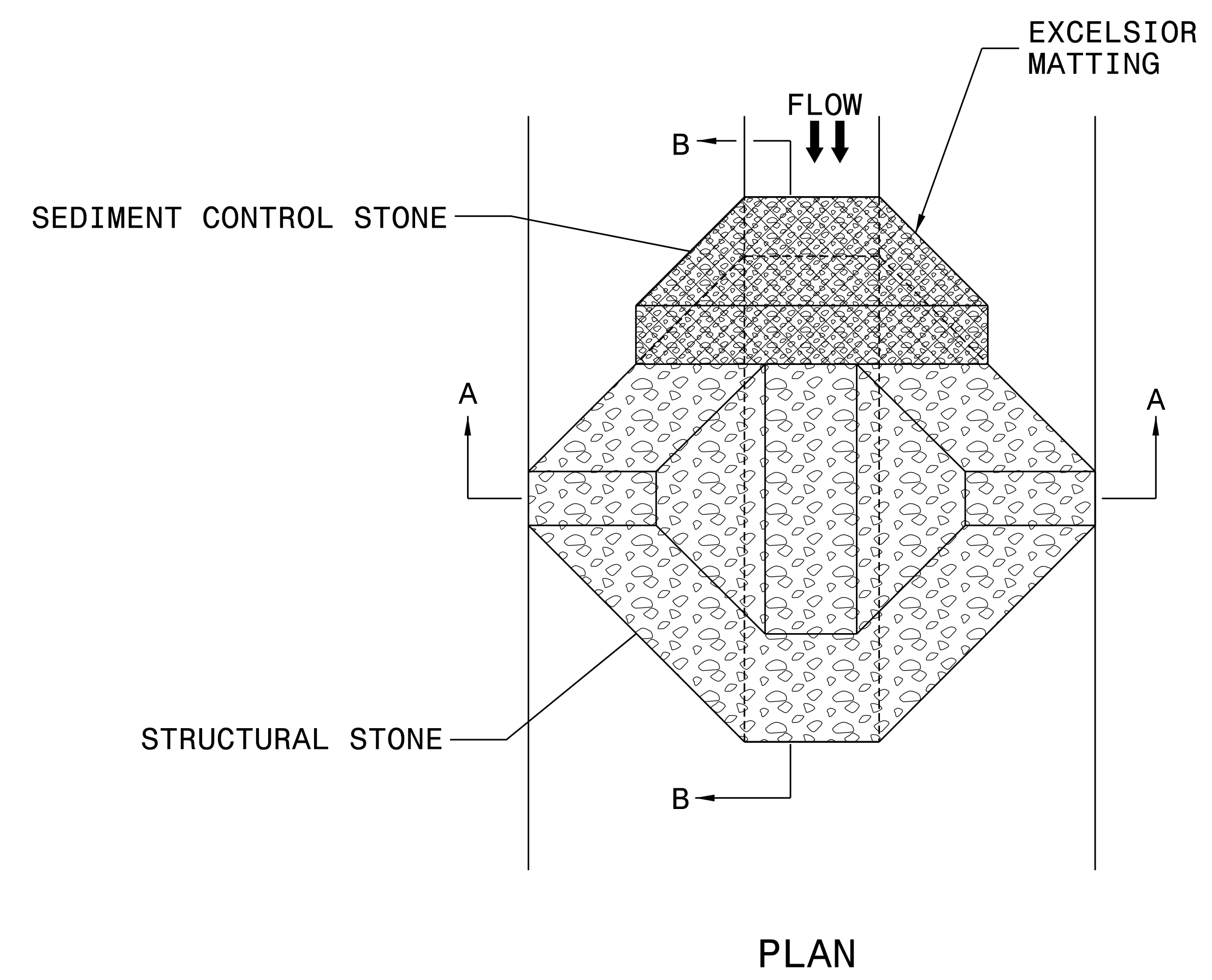

NOTES

USE EXCELSIOR FOR MATTING MATERIAL AND ANCHOR MATTING SECTION AT TOP AND BOTTOM WITH CLASS B STONE.

PRIOR TO POLYACRYLAMIDE (PAM) APPLICATION, OBTAIN A SOIL SAMPLE FROM PROJECT LOCATION, AND FROM OFFSITE MATERIAL, AND ANALYZE FOR APPROPRIATE PAM FLOCCULANT TO BE APPLIED TO EACH ROCK SILT CHECK.

INITIALLY APPLY 4 OUNCES OF POLYACRYLAMIDE (PAM) TO TOP OF MATTING SECTION AND AFTER EVERY RAINFALL EVENT THAT EQUALS OR EXCEEDS 0.50 INCHES.

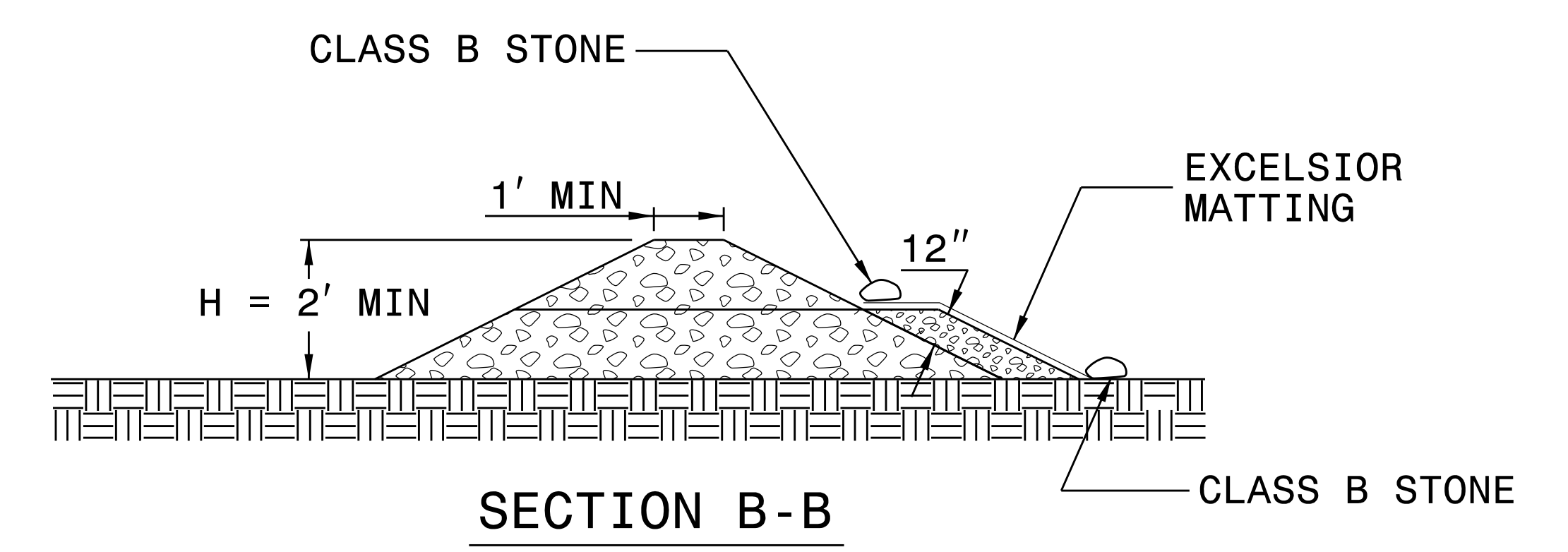
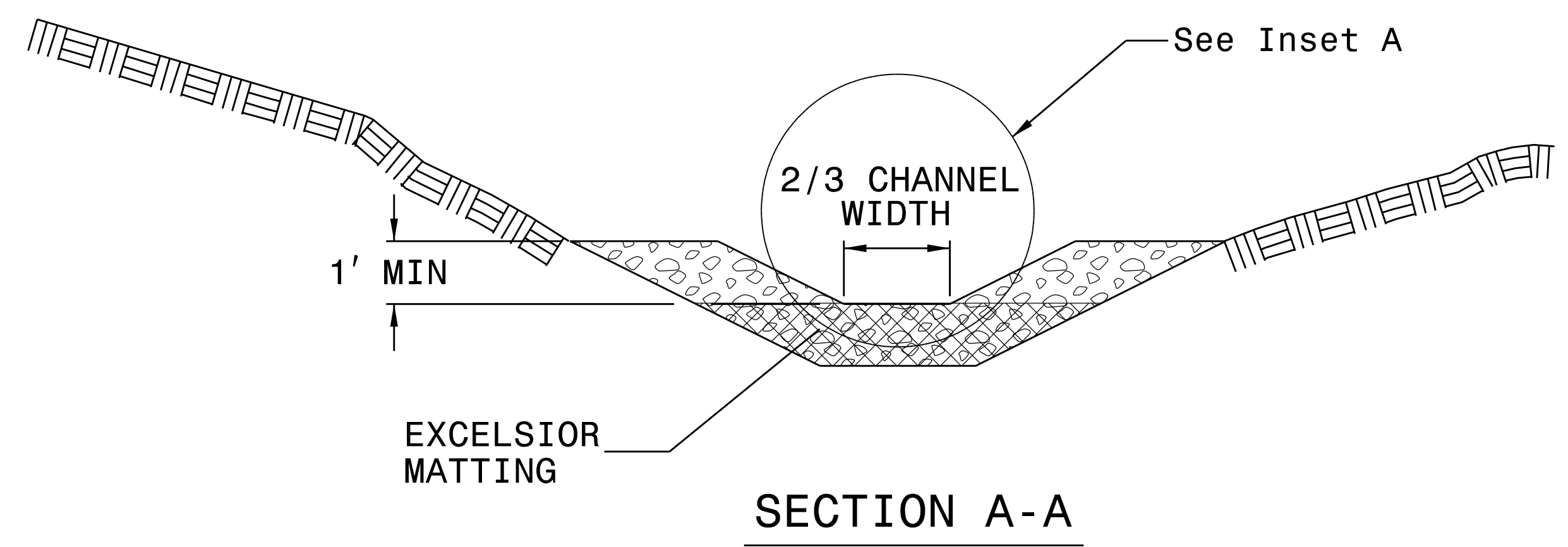
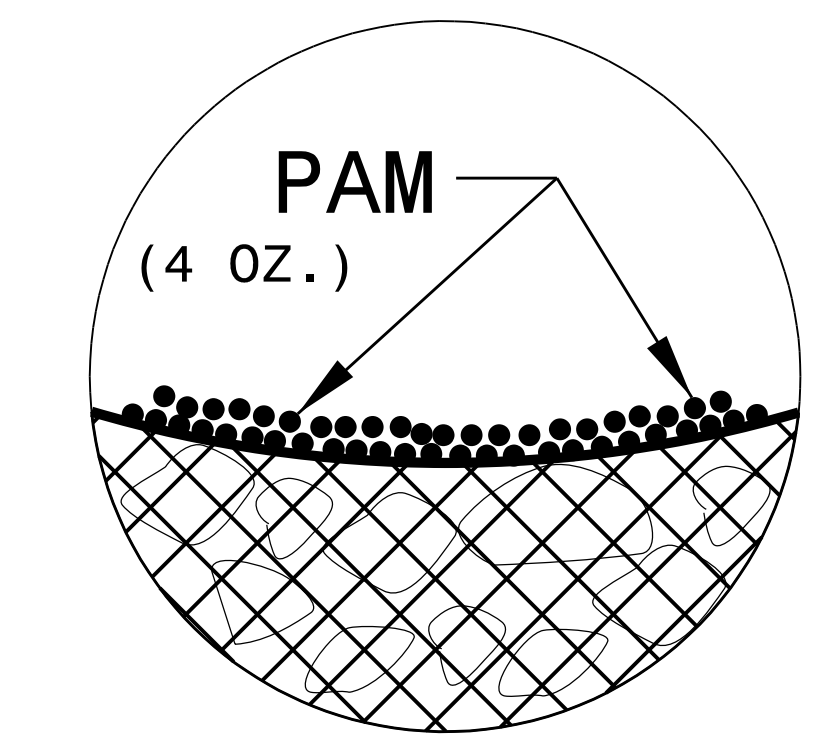

NOT TO SCALE

DIVISION OF HIGHWAYS
STATE OF NORTH CAROLINA

SOIL STABILIZATION TIMEFRAMES

| <i>SITE DESCRIPTION</i> | <i>STABILIZATION TIME</i> | <i>TIMEFRAME EXCEPTIONS</i> |
|--|---------------------------|--|
| PERIMETER DIKES, SWALES, DITCHES AND SLOPES | 7 DAYS | NONE |
| HIGH QUALITY WATER (HQW) ZONES | 7 DAYS | NONE |
| SLOPES STEEPER THAN 3:1 | 7 DAYS | IF SLOPES ARE 10' OR LESS IN LENGTH AND ARE NOT STEEPER THAN 2:1, 14 DAYS ARE ALLOWED. |
| SLOPES 3:1 OR FLATTER | 14 DAYS | 7 DAYS FOR SLOPES GREATER THAN 50' IN LENGTH. |
| ALL OTHER AREAS WITH SLOPES FLATTER THAN 4:1 | 14 DAYS | NONE, EXCEPT FOR PERIMETERS AND HQW ZONES. |

**CLEARING AND GRUBBING
 EROSION CONTROL FOR
 CONSTRUCTION SHEET 4**

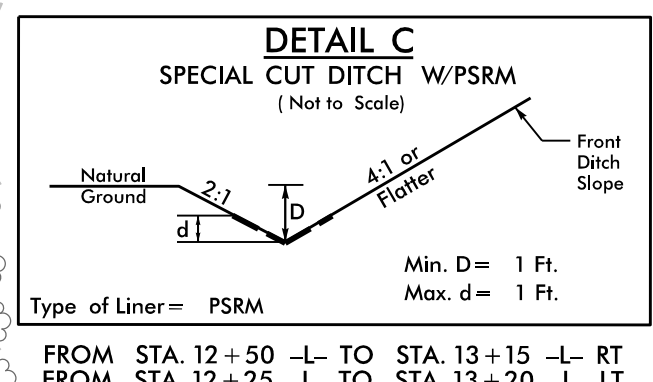
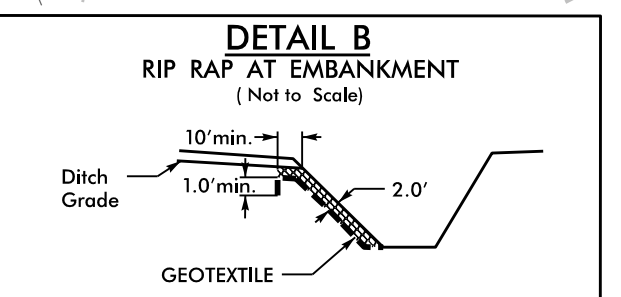
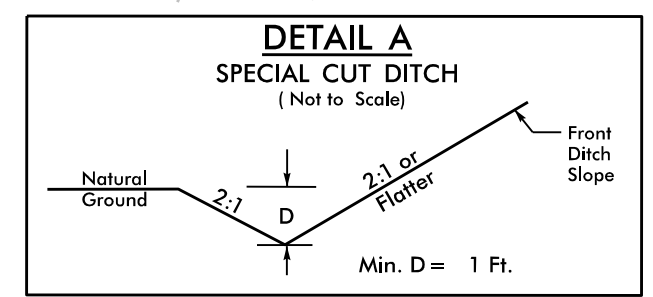
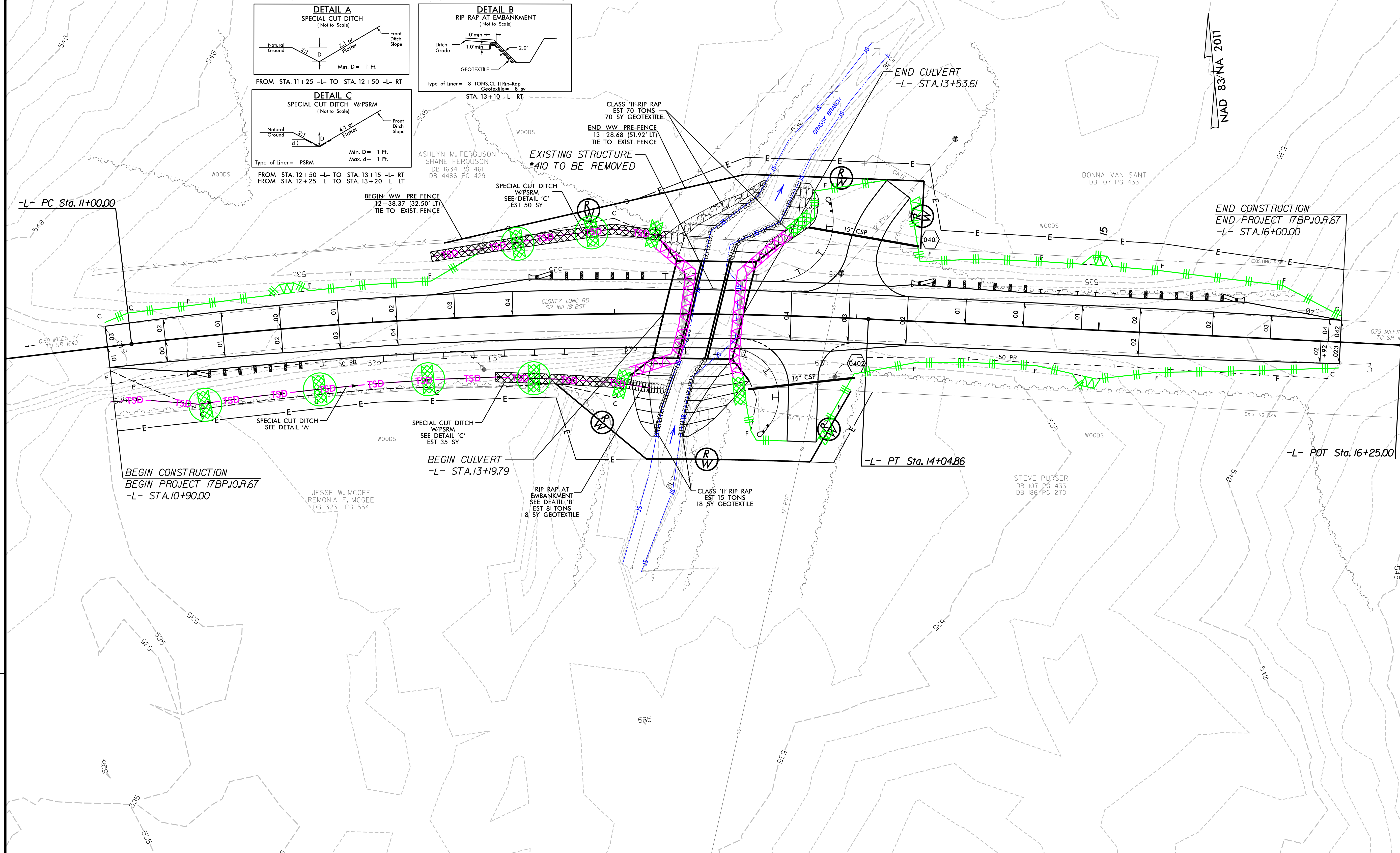

-L- PC Sta. 11+00.00

BEGIN CONSTRUCTION
 BEGIN PROJECT 17BP.JO.R.67
 -L- STA.10+90.00

BEGIN CULVERT
 -L- STA.13+19.79

-L- PT Sta. 14+04.86

END CONSTRUCTION
 END PROJECT 17BP.JO.R.67
 -L- STA.16+00.00

NAD 83/NA 2011

TRIPLE 10' X 6' RCBC CULVERT CONSTRUCTION SEQUENCE

PHASE I

1. INSTALL IMPERVIOUS DIKES UPSTREAM AND DOWNSTREAM OF THE PROPOSED CULVERT.
2. INSTALL 48" CSP TO CARRY CLEAN WATER AROUND THE WORK AREA AND ALLOW BARRELS 1 AND 2 TO BE CONSTRUCTED.
3. PROVIDE PUMP AND SPECIAL STILLING BASIN FOR DEWATERING THE WORK ZONE.
4. CONSTRUCT BARRELS 1 AND 2 ALONG WITH ASSOCIATED WING WALLS AND CHANNEL IMPROVEMENTS.
5. CONSTRUCT FLOODPLAIN BENCH FOR BARREL 1 WITH NATIVE BED MATERIAL AND STABILIZE BENCH FACE WITH CLASS 'II' RIP RAP.

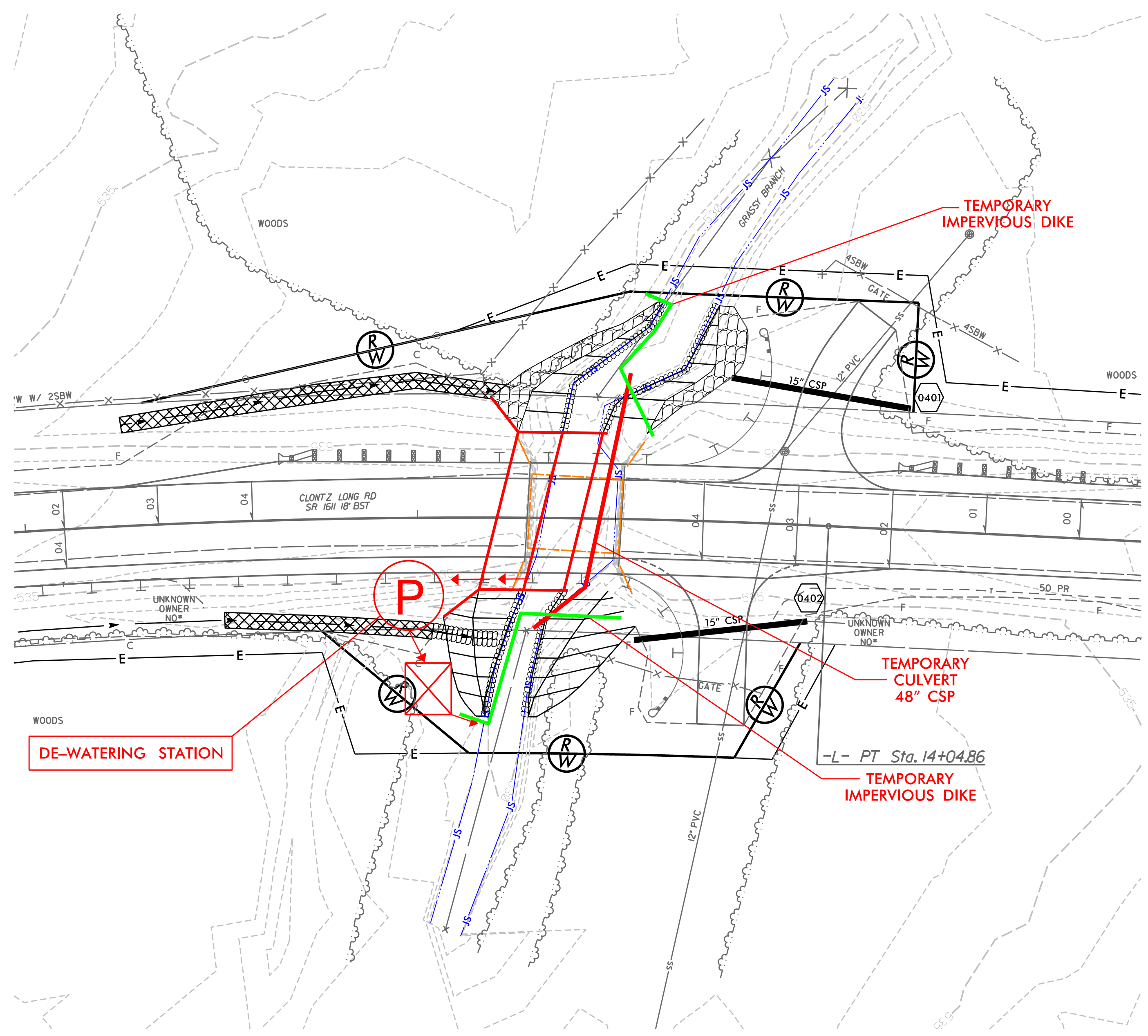

PHASE II

1. REMOVE TEMP. 48" CSP AND INSTALL TEMPORARY IMPERVIOUS DIKES AS SHOWN TO DIVERT STREAM INTO BARRELS 1 AND 2.
2. PROVIDE PUMP AND SPECIAL STILLING BASIN FOR DEWATERING THE WORK ZONE FOR THE CONSTRUCTION OF BARREL 3.
3. CONSTRUCT BARREL 3 INCLUDING ASSOCIATED WINGWALLS AND CHANNEL IMPROVEMENTS.
4. CONSTRUCT FLOODPLAIN BENCH FOR BARREL 3 WITH NATIVE BED MATERIAL AND STABILIZE BENCH FACE WITH CLASS 'II' RIP RAP.
5. REMOVE IMPERVIOUS DIKES AND DEWATERING STATION.
6. REMOVE EROSION CONTROL DEVICES AND BEGIN ROADWAY IMPROVEMENTS.

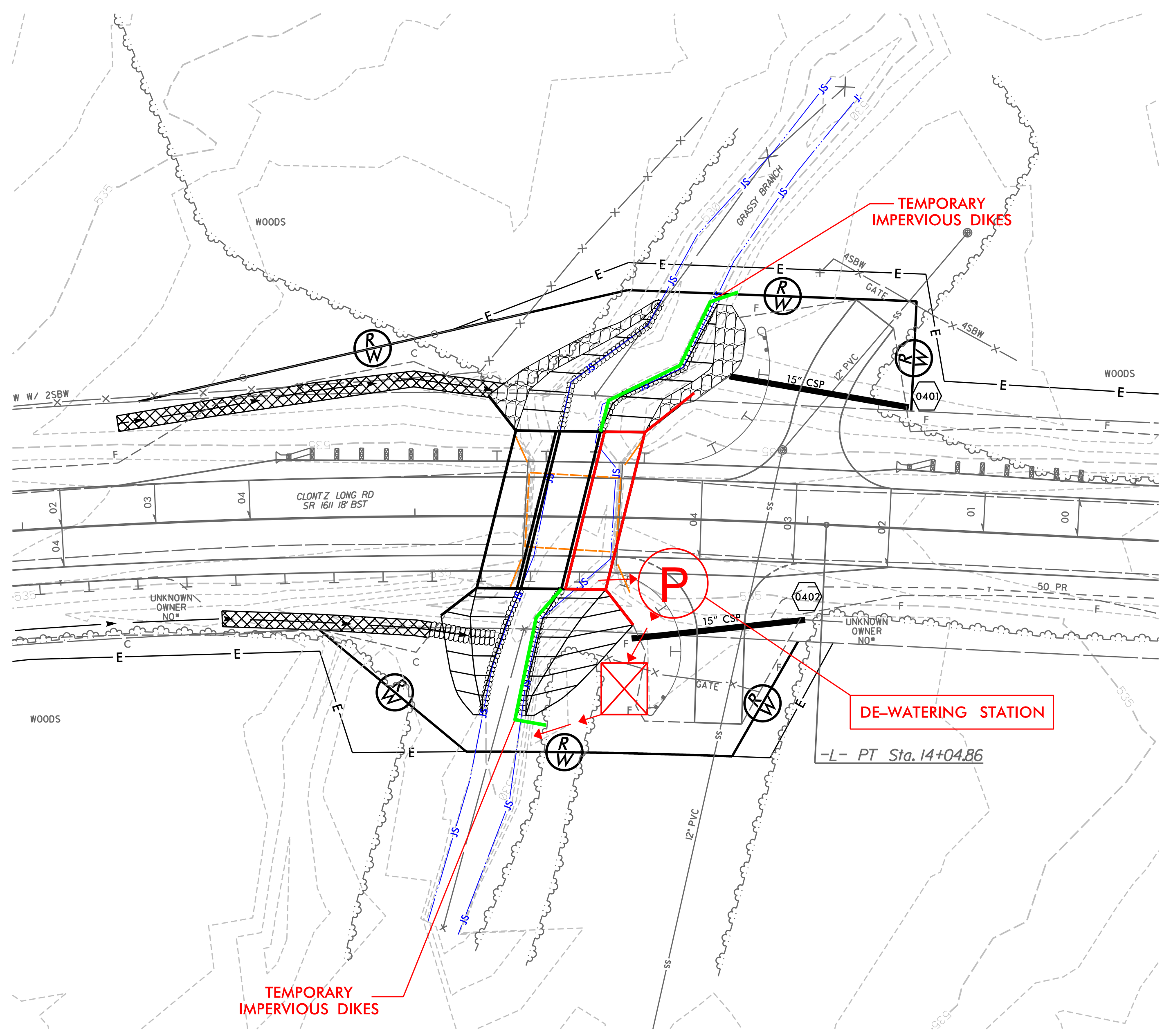

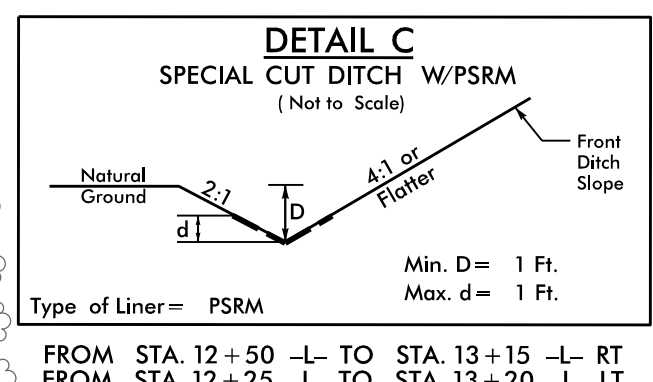
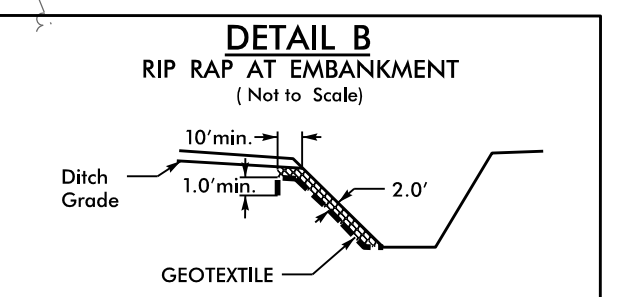
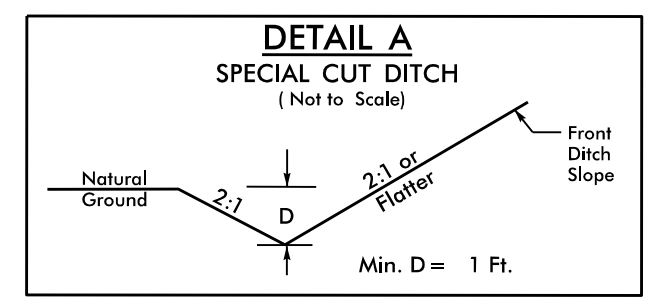
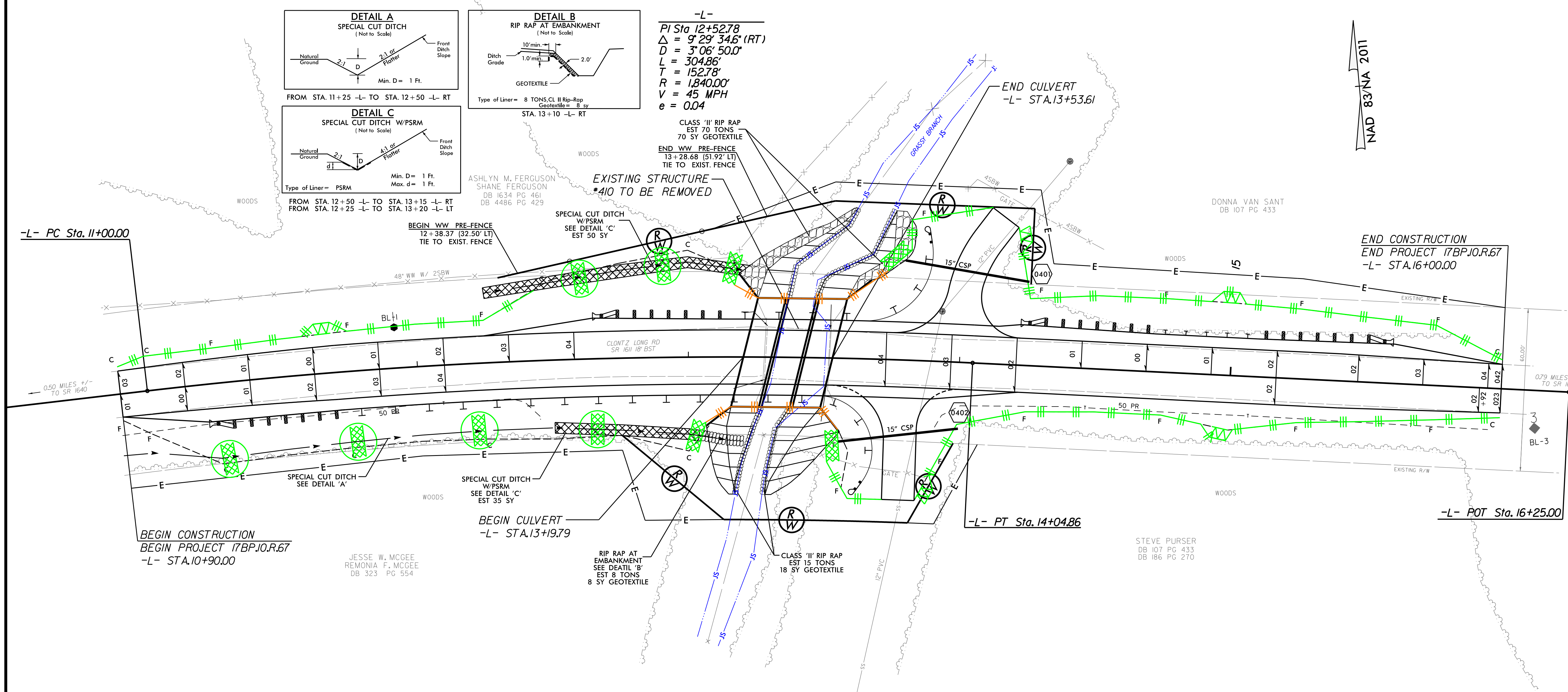

-L-
 PI Sta 12+52.78
 $\Delta = 9^{\circ} 29' 34.6''$ (RT)
 $D = 3^{\circ} 06' 50.0''$
 $L = 304.86'$
 $T = 152.78'$
 $R = 1,840.00'$
 $V = 45$ MPH
 $e = 0.04$

NAD 83/NA 2011

-L- PC Sta. 11+00.00

END CONSTRUCTION
 END PROJECT 17BP.JO.R.67
 -L- STA. 16+00.00

BEGIN CONSTRUCTION
 BEGIN PROJECT 17BP.JO.R.67
 -L- STA. 10+90.00

JESSE W. MCGEE
 REMONIA F. MCGEE
 DB 323 PG 554

RIP RAP AT EMBANKMENT
 SEE DETAIL 'B'
 EST 8 TONS
 8 SY GEOTEXTILE

STEVE PURSER
 DB 107 PG 433
 DB 186 PG 270

CONTRACT: - STATE PROJECT: 17BP.10.R.67

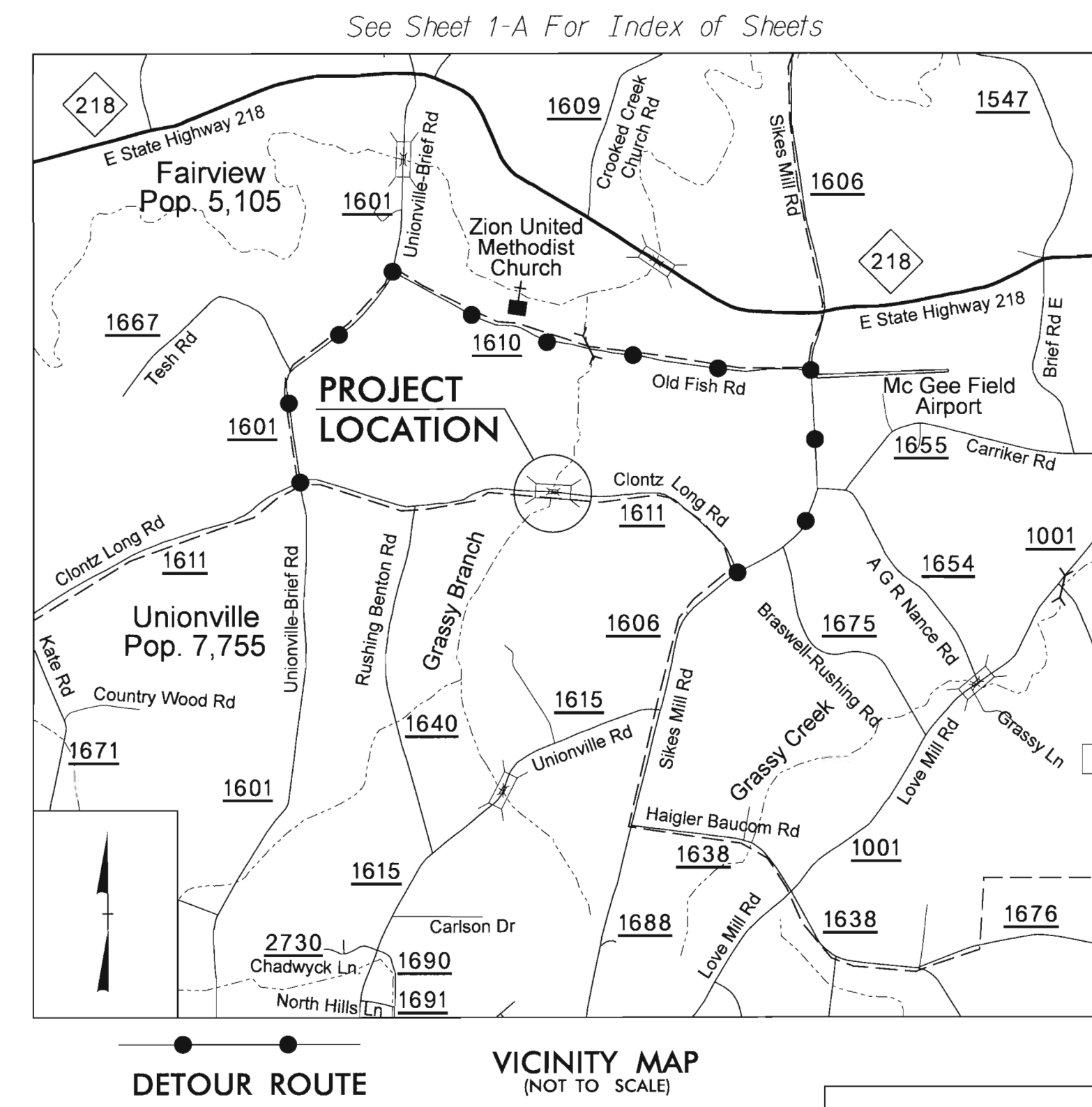

STATE OF NORTH CAROLINA
DIVISION OF HIGHWAYS

UTILITY CONSTRUCTION PLANS UNION COUNTY

**LOCATION: BRIDGE NO. 410 ON SR 1611 OVER GRASSY BRANCH
BETWEEN SR 1640 AND SR 1606**

TYPE OF WORK: UTILITY CONSTRUCTION

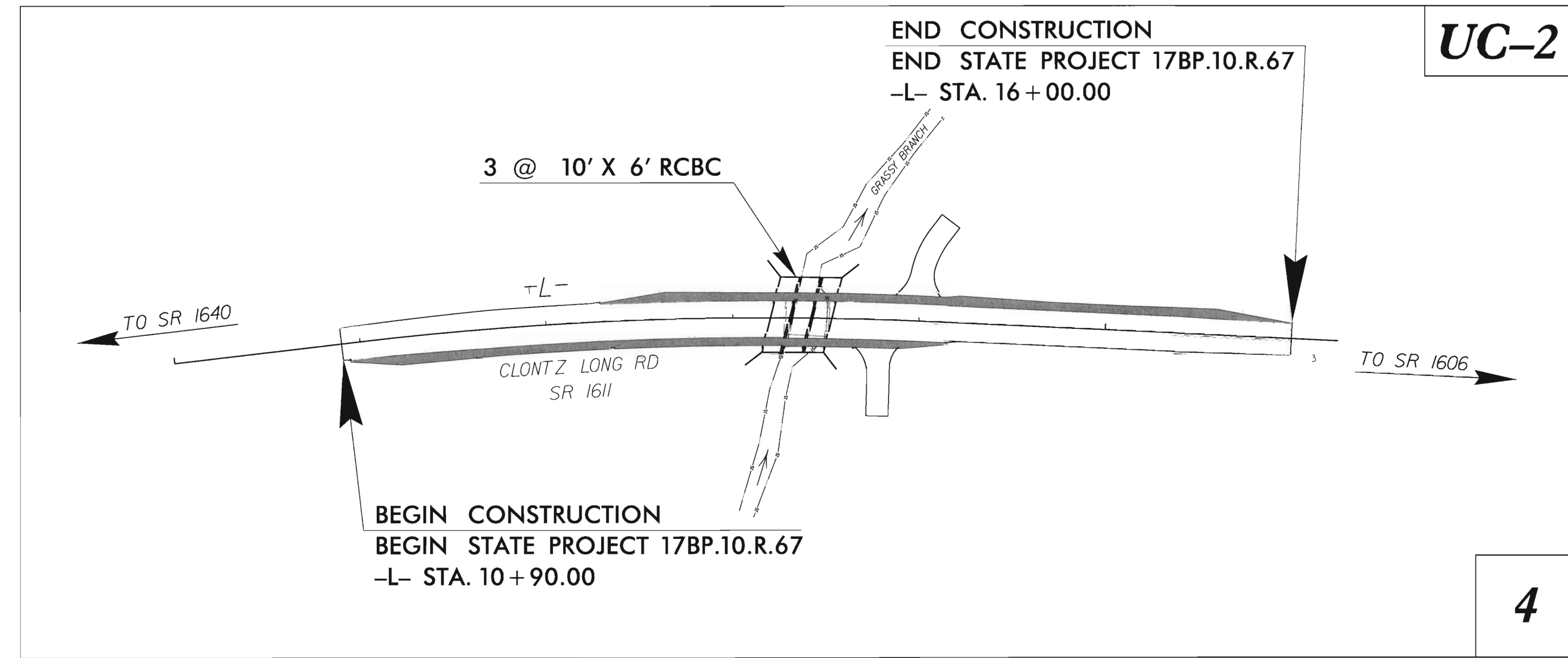

RELEASE FOR CONSTRUCTION
DATE: 08/27/15

HDR HDR Engineering, Inc. of the Carolinas
3733 National Drive, Suite 207 Raleigh, N.C. 27612
N.C.B.E.L.S. License Number: F-0116

CLEARING ON THIS PROJECT SHALL BE PERFORMED TO THE LIMITS ESTABLISHED BY METHOD II.
A PORTION OF THIS PROJECT IS WITHIN THE MUNICIPAL BOUNDARIES OF UNIONVILLE.

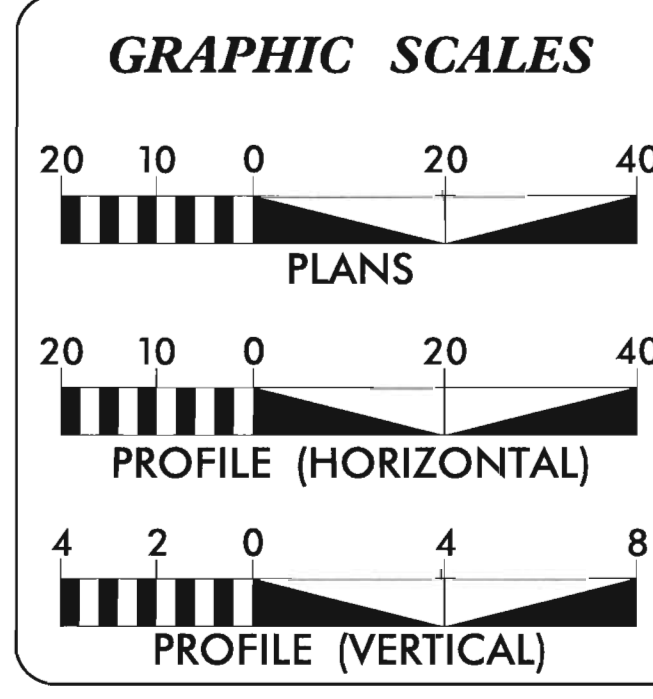

| SHEET NO. | DESCRIPTION |
|-----------|------------------------------|
| UC-1 | TITLE SHEET |
| UC-2 | PLAN & PROFILE |
| UC-3 | UTILITY CONSTRUCTION DETAILS |

WATER AND SEWER OWNERS ON PROJECT

(1) WATER - UNION COUNTY PUBLIC WORKS

Prepared in the Office of:
DIVISION OF HIGHWAYS
1000 Birch Ridge Dr., Raleigh NC, 27610

2012 STANDARD SPECIFICATIONS
RIGHT OF WAY DATE: DOMINIC M. WAINWRIGHT, P.E.
PROJECT ENGINEER

LETTING DATE: JAMES R. RICE, P.E.
PROJECT DESIGN ENGINEER

MICHAEL V. ZACCARDO, PE
UTILITY DESIGN ENGINEER

NCDOT CONTACT: PRIORITY PROJECT OFFICE

**DIVISION OF HIGHWAYS
STATE OF NORTH CAROLINA**

LOUIS MITCHELL P.E.
DIVISION ENGINEER

\$\$\$\$\$SYTIME\$\$\$\$\$
\$\$\$\$\$DGN\$\$\$\$\$
\$\$\$\$\$SERNAME\$\$\$\$\$

8/17/99

| | | | |
|--|--------------|---------------------------------|------|
| PROJECT REFERENCE NO. | 17BP.10.R.67 | SHEET NO. | UC-2 |
| DESIGNED BY: | JDS | | |
| DRAWN BY: | JDS | | |
| CHECKED BY: | MVZ | | |
| APPROVED BY: | MVZ | | |
| REVISED: | | | |
| NORTH CAROLINA DEPARTMENT OF TRANSPORTATION | | UTILITY CONSTRUCTION PLANS ONLY | |
| UTILITIES ENGINEERING SEC. PHONE: (919) 707-6690 FAX: (919) 250-4151 | | | |

RAISE EXISTING MH RIM AND COVER BY REMOVING TOP CONE SECTION, INSTALLING A NEW RISER SECTION, AND REINSTALLING THE EXISTING CONE SECTION.
(SEE NOTE THIS SHEET)
(SEE DETAIL SHEET UC-3)

EXISTING SSMH
RIM=535.07
INV=523.88
PROPOSED ADJUSTED SSMH
RIM=537.20 +/-

UTILITY CONSTRUCTION

RELEASE FOR CONSTRUCTION
DATE: 08/27/15

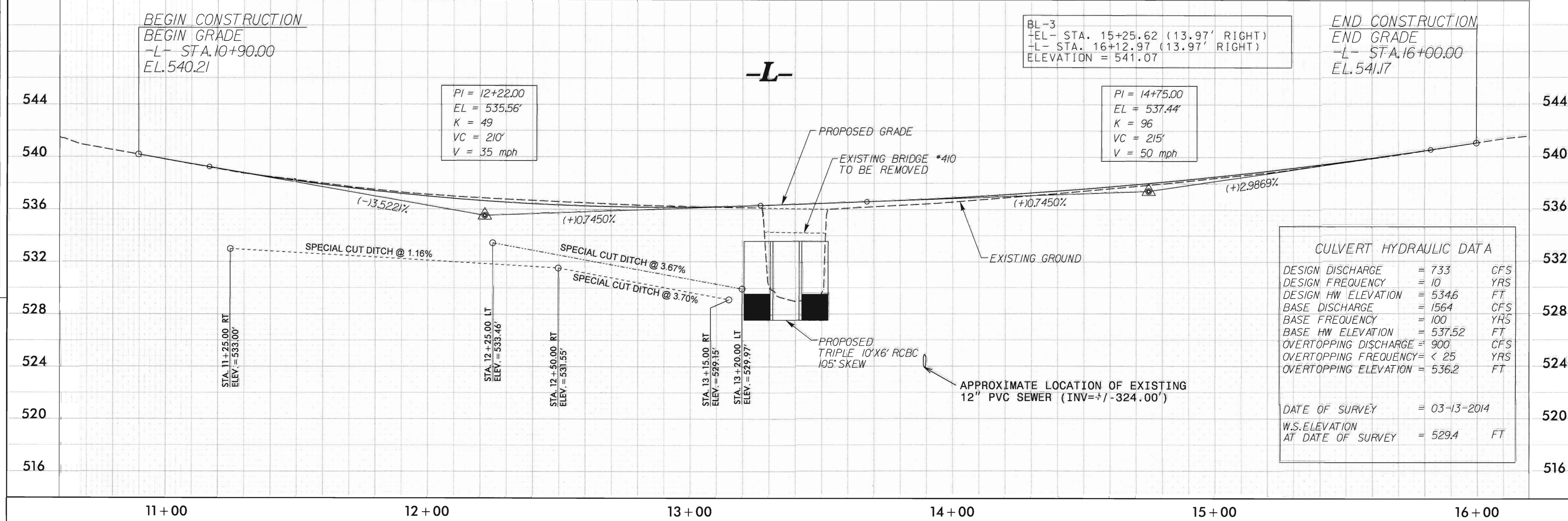
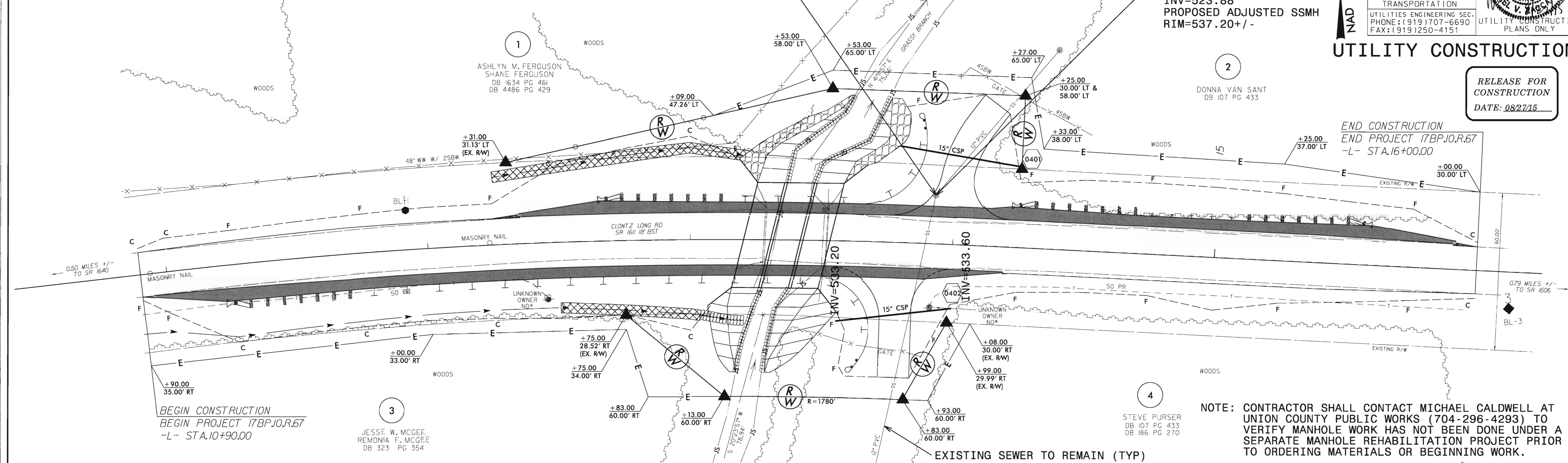

REVISIONS

| | |
|---|---|
| PROJECT REFERENCE NO. 17BP.10.R.67 | SHEET NO. UC-3 |
| DESIGNED BY: JDS |  |
| DRAWN BY: JDS | |
| CHECKED BY: MVZ | |
| APPROVED BY: MVZ | |
| REVISED: | |
| NORTH CAROLINA DEPARTMENT OF TRANSPORTATION UTILITIES ENGINEERING SEC. PHONE: (919) 707-6690 FAX: (919) 250-4151 | |
| UTILITY CONSTRUCTION PLANS ONLY | |

NOTE: CONTRACTOR SHALL CONTACT MICHAEL CALDWELL AT UNION COUNTY PUBLIC WORKS (704-296-4293) TO VERIFY MANHOLE WORK HAS NOT BEEN DONE UNDER A SEPARATE MANHOLE REHABILITATION PROJECT PRIOR TO ORDERING MATERIALS OR BEGINNING WORK.

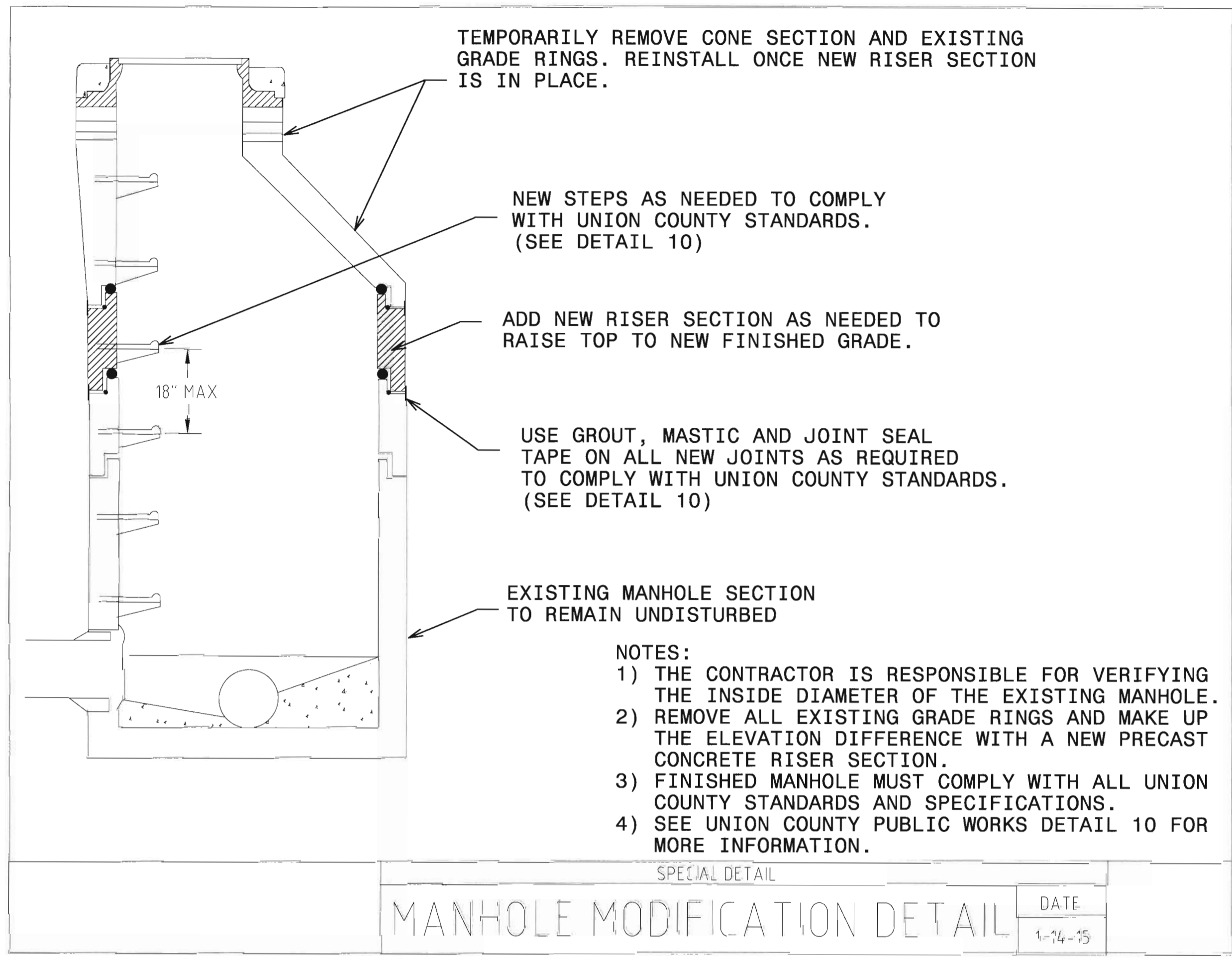

UTILITY CONSTRUCTION

RELEASE FOR
CONSTRUCTION
DATE: 08/27/15

09/08/15

STATE PROJECT: 17BP.10.R.67

| | |
|--------------|-----------|
| T.I.P. NO. | SHEET NO. |
| 17BP.10.R.67 | UO-1 |

STATE OF NORTH CAROLINA
DIVISION OF HIGHWAYS

**UTILITIES BY OTHERS PLANS
UNION COUNTY**

**LOCATION: BRIDGE NO. 410 ON SR 1611 OVER GRASSY BRANCH
BETWEEN SR 1640 AND SR 1606**

TYPE OF WORK: UTILITIES BY OTHERS

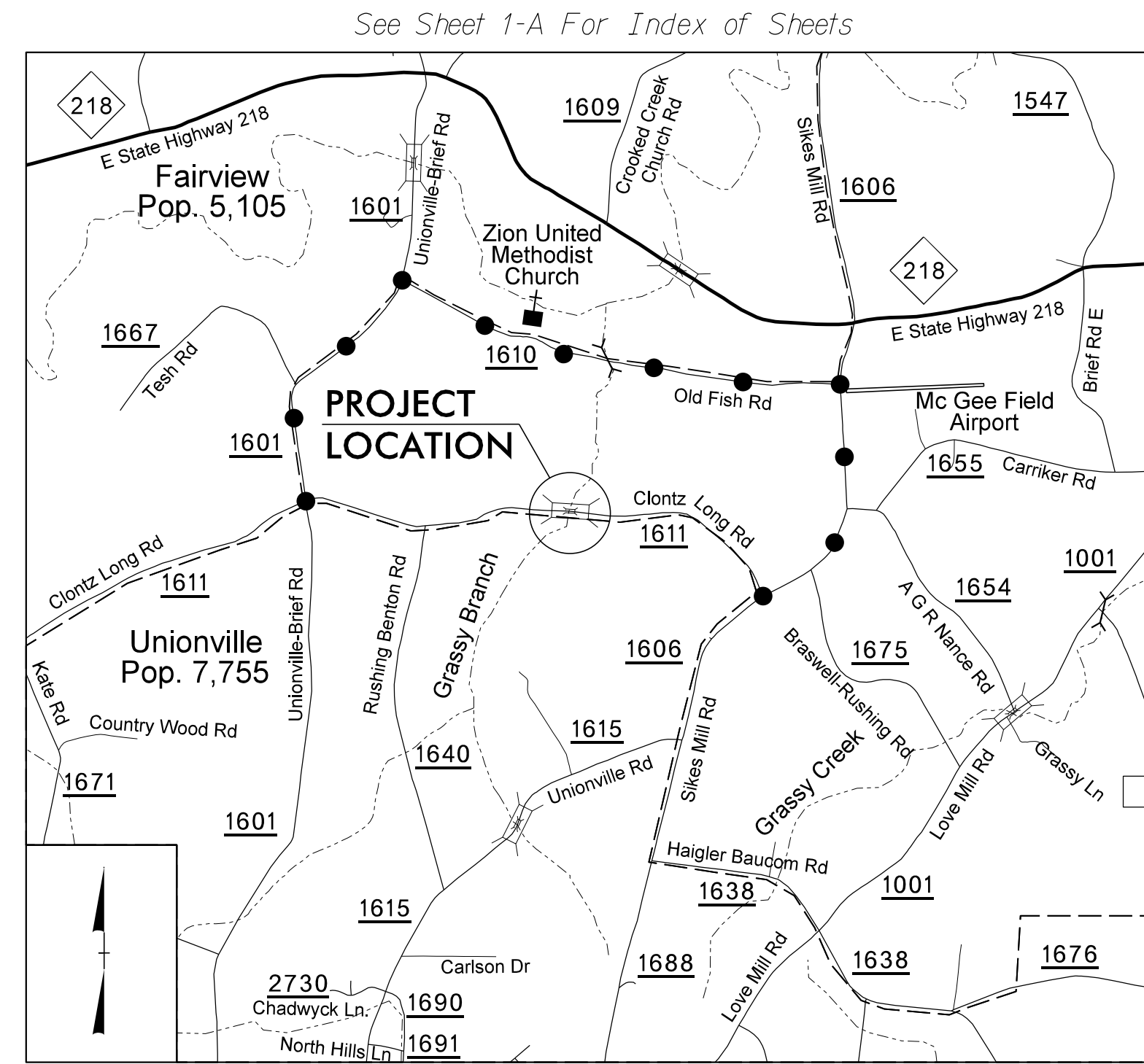

DETOUR ROUTE
VICINITY MAP
(NOT TO SCALE)

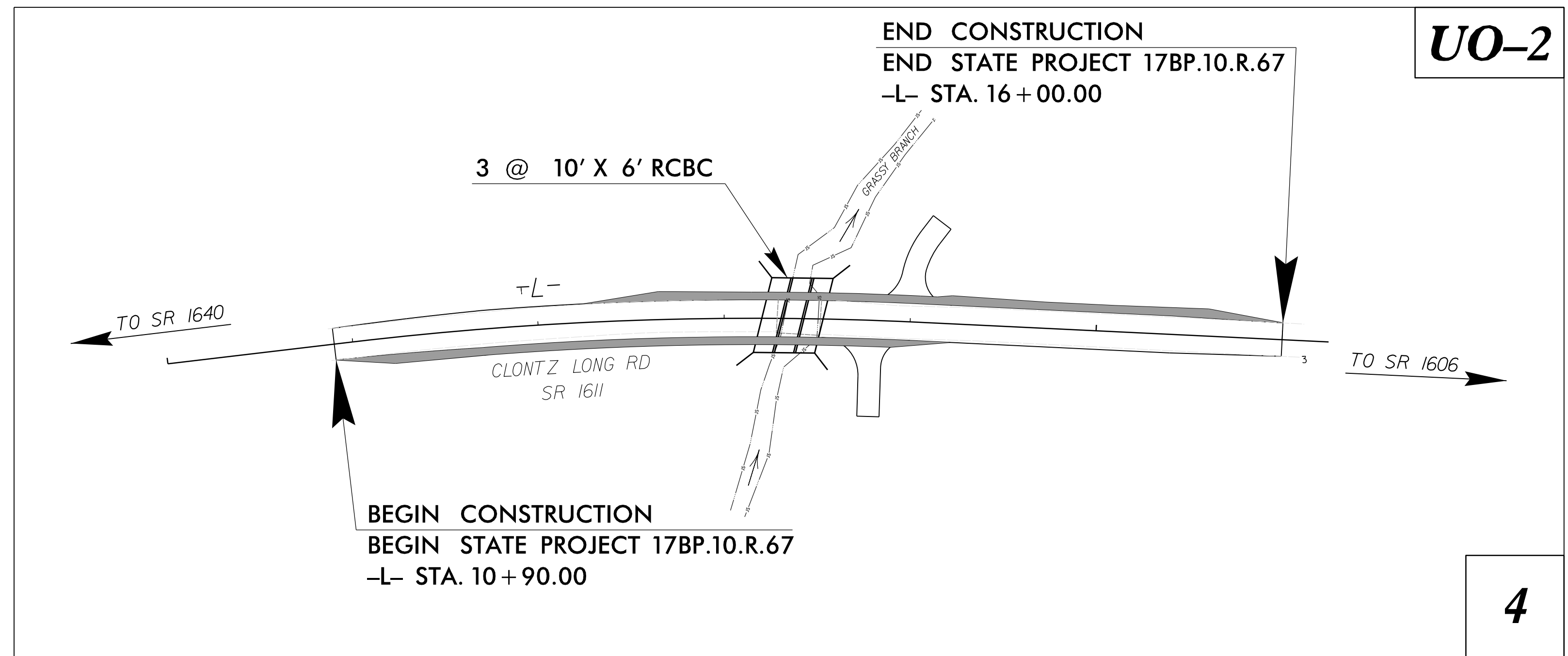
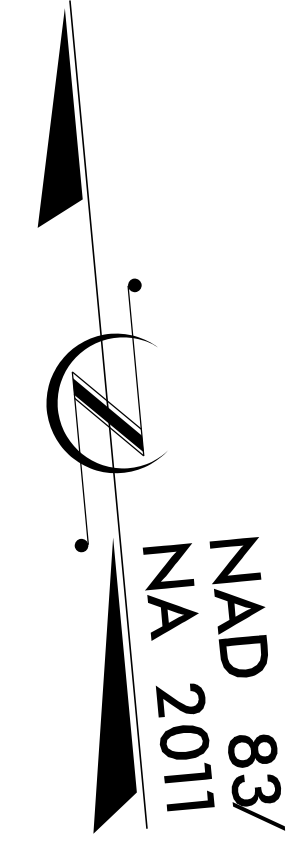

LOCATION SKETCH

RELEASE FOR
CONSTRUCTION
DATE: 08/10/15

CLEARING ON THIS PROJECT SHALL BE PERFORMED TO THE LIMITS ESTABLISHED BY METHOD II.
A PORTION OF THIS PROJECT IS WITHIN THE MUNICIPAL BOUNDARIES OF UNIONVILLE.

HDR HDR Engineering, Inc. of the Carolinas
3733 National Drive, Suite 207 Raleigh, N.C. 27612
N.C.B.E.L.S. License Number: F-0116

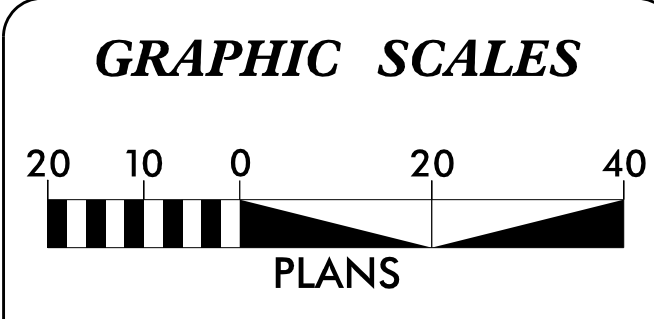

| SHEET NO. | DESCRIPTION |
|-----------|-------------------------------|
| UO-1 | TITLE SHEET |
| UO-2 | UTILITY BY OTHERS PLAN SHEETS |

UTILITY OWNERS ON PROJECT

(A) PHONE- FRONTIER

Prepared in the Office of:
DIVISION OF HIGHWAYS
1000 Birch Ridge Dr., Raleigh NC, 27610

2012 STANDARD SPECIFICATIONS
RIGHT OF WAY DATE: DOMINIC M. WAINWRIGHT, P.E.
PROJECT ENGINEER

LETTING DATE: JAMES R. RICE, P.E.
PROJECT DESIGN ENGINEER

MICHAEL V. ZACCARDO, PE
UTILITY DESIGN ENGINEER

NCDOT CONTACT: PRIORITY PROJECT OFFICE

**DIVISION OF HIGHWAYS
STATE OF NORTH CAROLINA**

LOUIS MITCHELL P.E.
DIVISION ENGINEER

\$\$\$ SYSTEMS \$\$\$
\$\$\$ DGN \$\$\$
\$\$\$ USERNAME \$\$\$

CONTRACT: -

UTILITIES BY OTHERS

NOTE:
ALL PROPOSED UTILITY WORK SHOWN ON THIS SHEET WILL BE DONE BY OTHERS. NO PAYMENT WILL BE MADE TO THE CONTRACTOR FOR PROPOSED UTILITY WORK SHOWN ON THIS SHEET.

RELEASE FOR
CONSTRUCTION
DATE: 08/10/15

5/14/99
10 Union
10/28/08 M:
8/28/10
8/18/2015
C:\Users\rdy\OneDrive\Projects\17BP-10R67\ut_rdy4_U02.psh.dgn

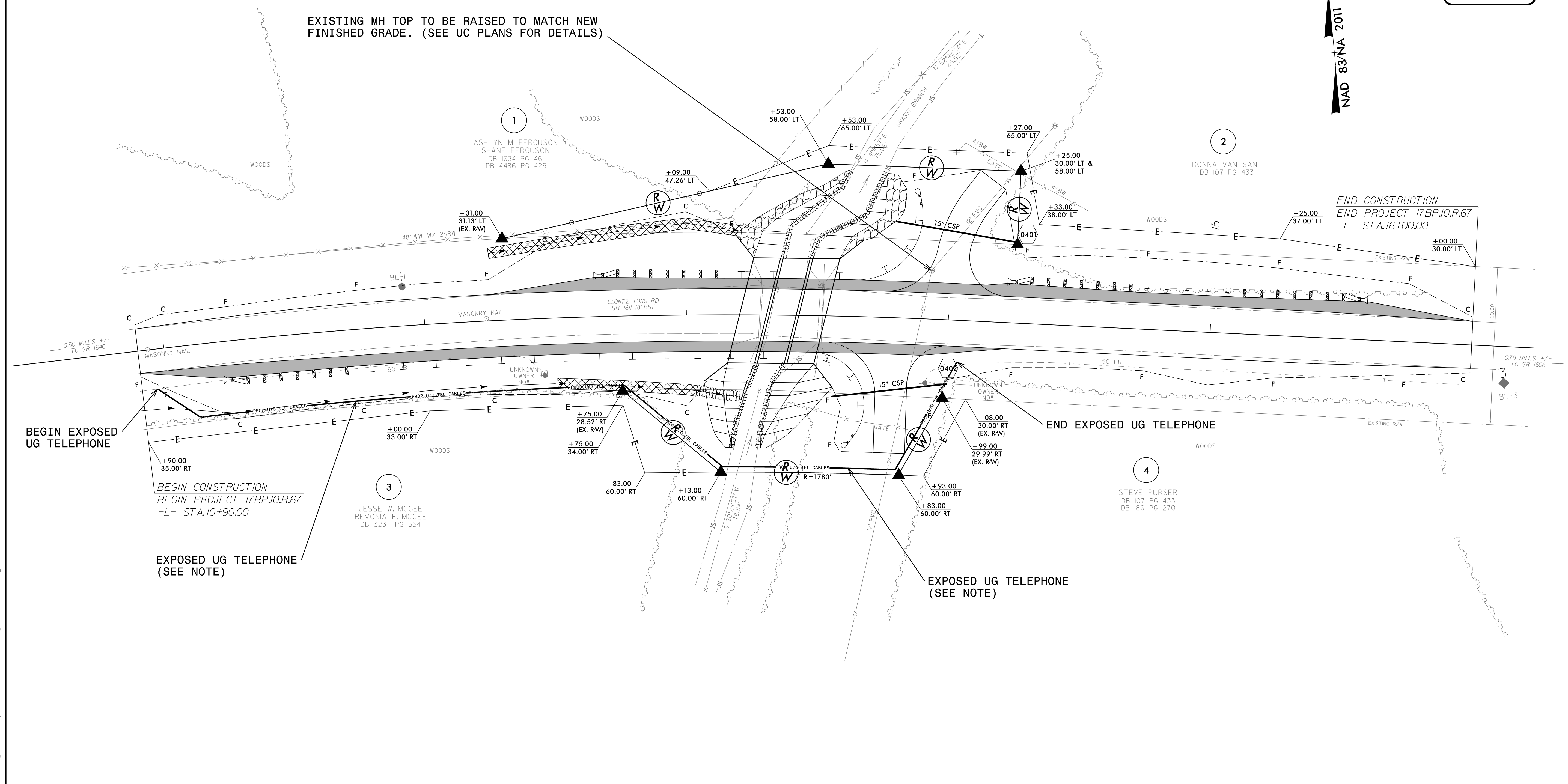

EXISTING MH TOP TO BE RAISED TO MATCH NEW FINISHED GRADE. (SEE UC PLANS FOR DETAILS)

BEGIN EXPOSED UG TELEPHONE

BEGIN CONSTRUCTION
BEGIN PROJECT 17BP.10.R.67
-L- STA.10+90.00

EXPOSED UG TELEPHONE
(SEE NOTE)

END EXPOSED UG TELEPHONE

EXPOSED UG TELEPHONE
(SEE NOTE)

END CONSTRUCTION
END PROJECT 17BP.10.R.67
-L- STA.16+00.00

NOTE: EXISTING UG TELEPHONE TO BE EXPOSED AND LEFT ON THE SURFACE OF THE GROUND. CONTRACTOR CAN ADJUST LOCATION OF LINE AS NEEDED TO ACCOMMODATE WORK. LINES TO BE REBURIED AFTER CONSTRUCTION IS COMPLETE.

8/23/99

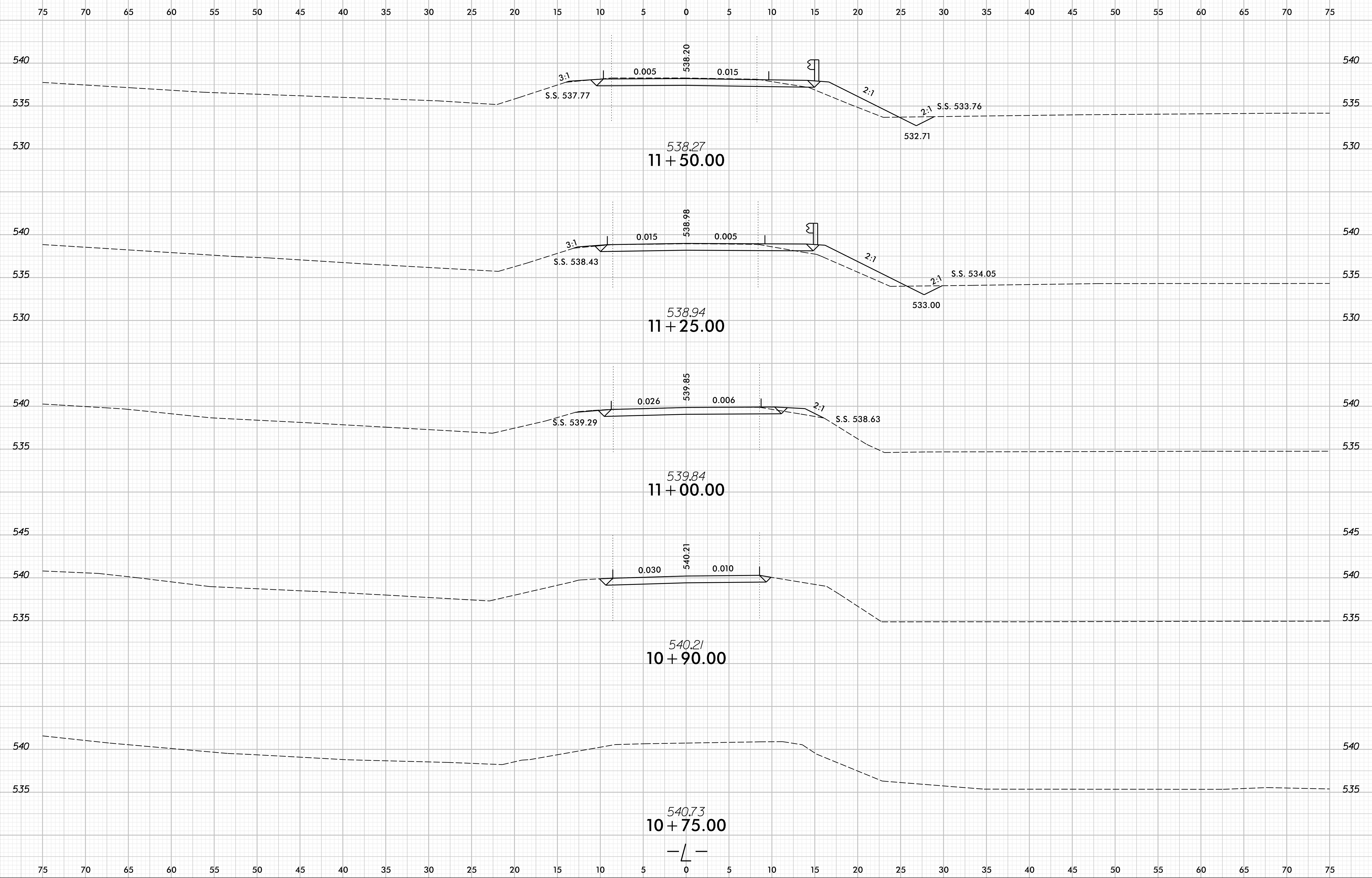

3/17/2017 5:15:00 PM \\p01\work\17BP\10R\67\RDY_XPL.DGN

8/23/99



| | |
|---------------------|-----------|
| PROJ. REFERENCE NO. | SHEET NO. |
| 17BP.10.R.67 | X-2 |

75 70 65 60 55 50 45 40 35 30 25 20 15 10 5 0 5 10 15 20 25 30 35 40 45 50 55 60 65 70 75

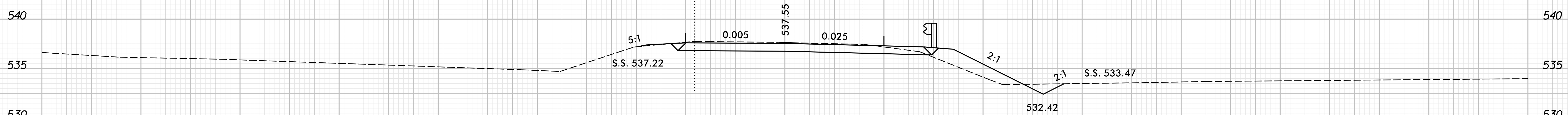
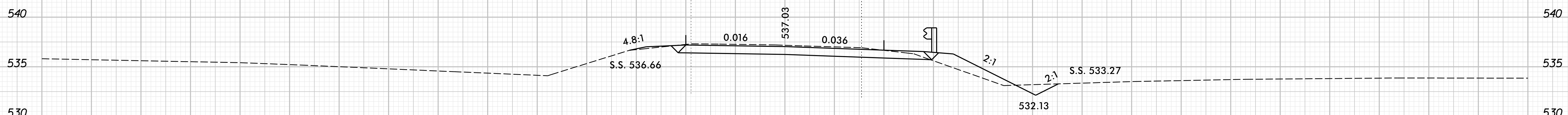
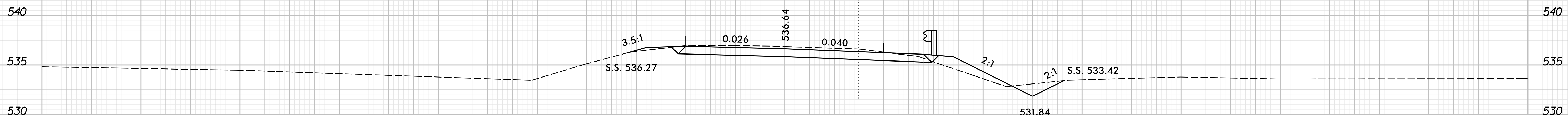
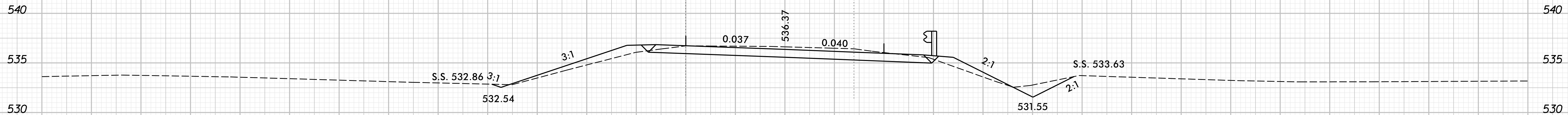

75 70 65 60 55 50 45 40 35 30 25 20 15 10 5 0 5 10 15 20 25 30 35 40 45 50 55 60 65 70 75

3/17/2017
 S:\Projects\17BP\10.R\17BP-10R67_RDY_XPL.DGN
 2:15:16 PM

8/23/99



PROJ. REFERENCE NO.
17BP.10.R.67

SHEET NO.
X-3

75 70 65 60 55 50 45 40 35 30 25 20 15 10 5 0 5 10 15 20 25 30 35 40 45 50 55 60 65 70 75

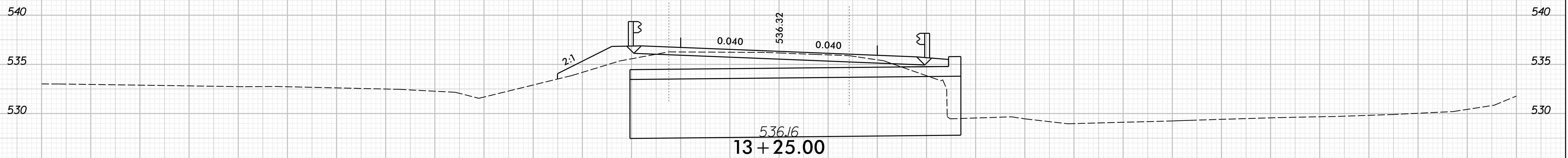
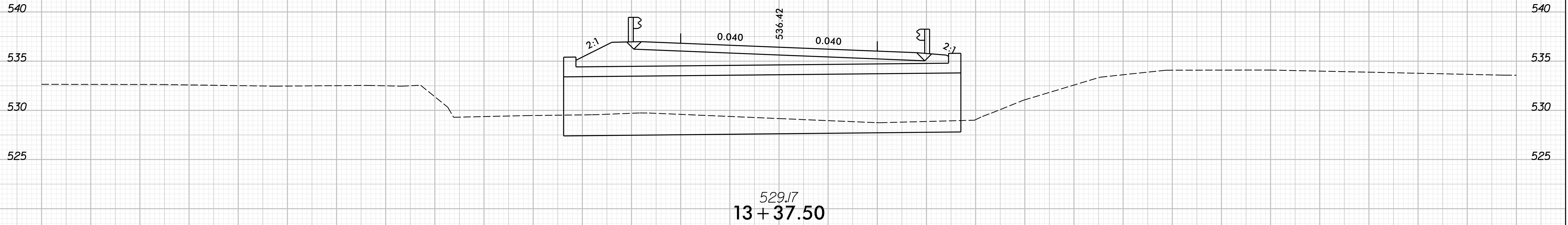

BEGIN CULVERT STA. 13 + 19.79

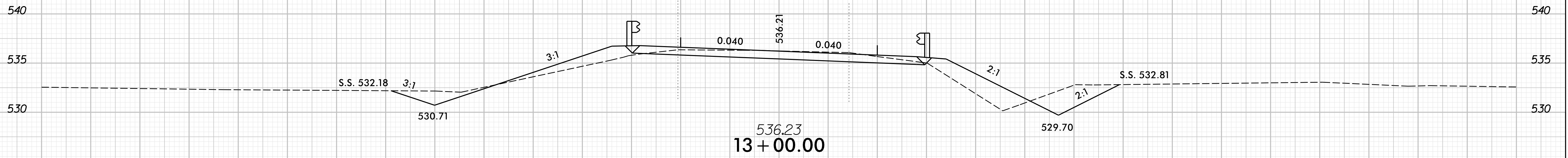

536.40
12 + 75.00

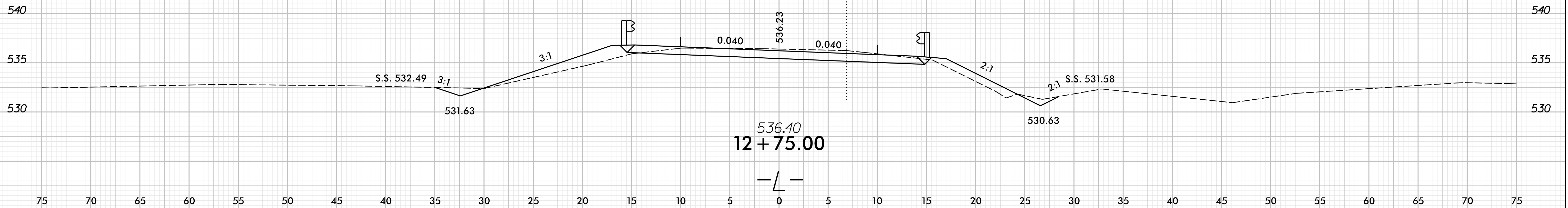

75 70 65 60 55 50 45 40 35 30 25 20 15 10 5 0 5 10 15 20 25 30 35 40 45 50 55 60 65 70 75

3/17/2017
S:\Projects\17BP\10\17BP-10R67-RDY_XPL.DGN

8/23/99

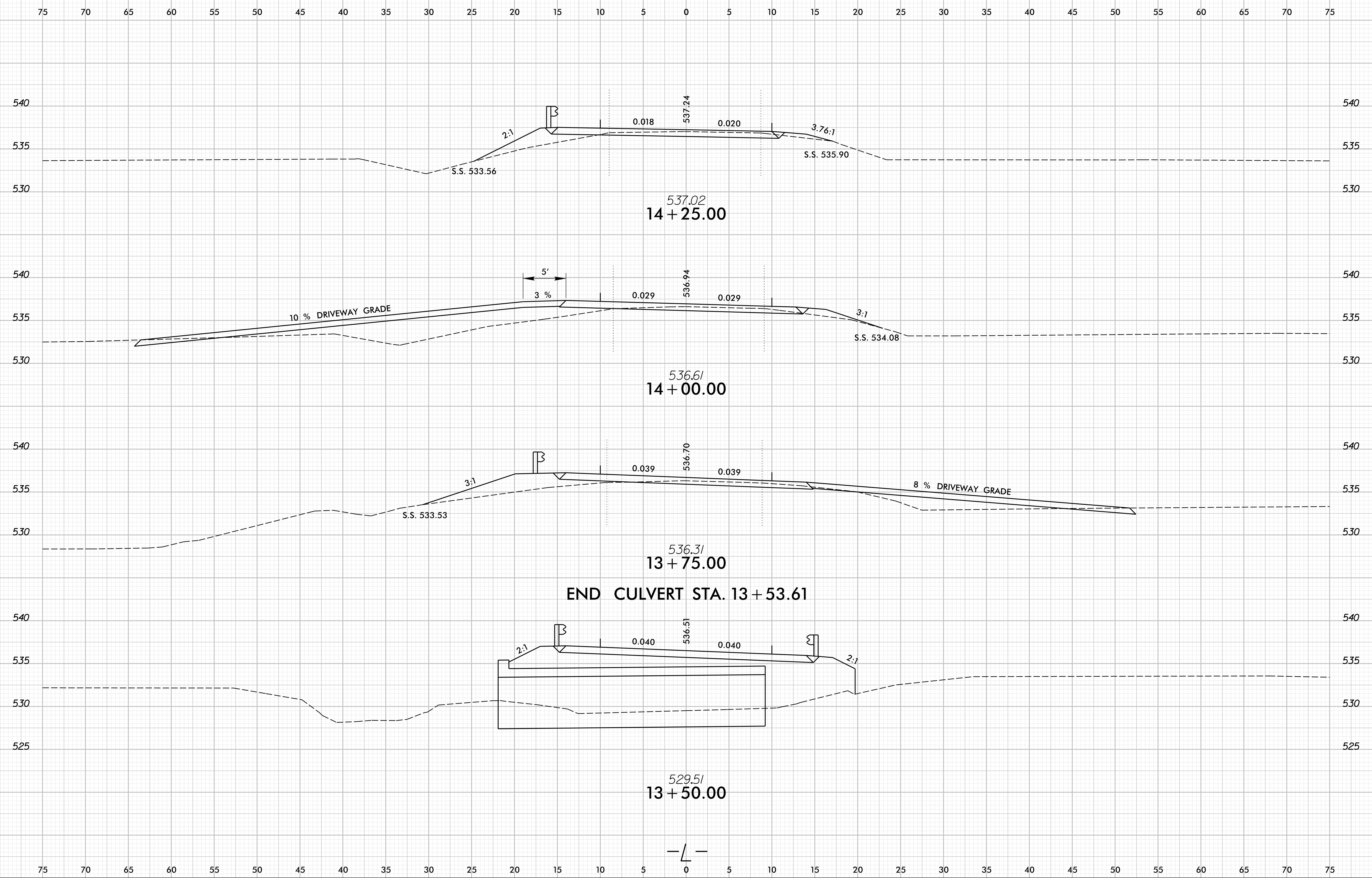

3/17/2017
S:\Projects\17BP\10.R\67\17BP-10R67-RDY_XPL.DGN

8/23/99



PROJ. REFERENCE NO.
17BP.10.R.67

SHEET NO.
X-5

75 70 65 60 55 50 45 40 35 30 25 20 15 10 5 0 5 10 15 20 25 30 35 40 45 50 55 60 65 70 75

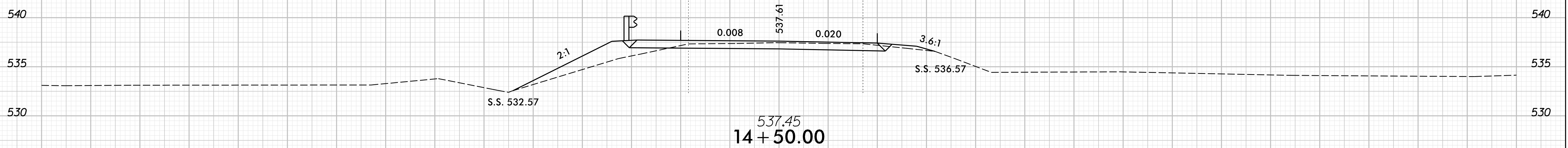
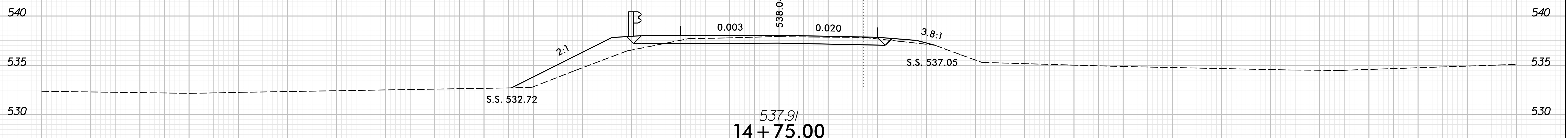
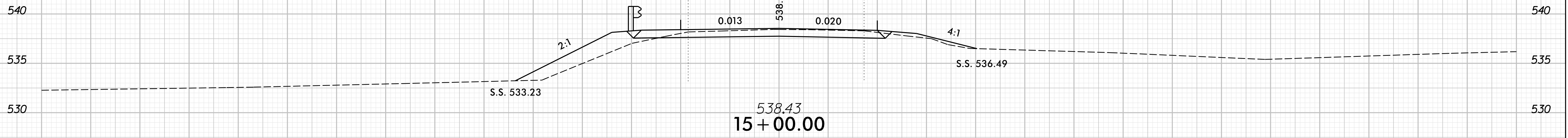
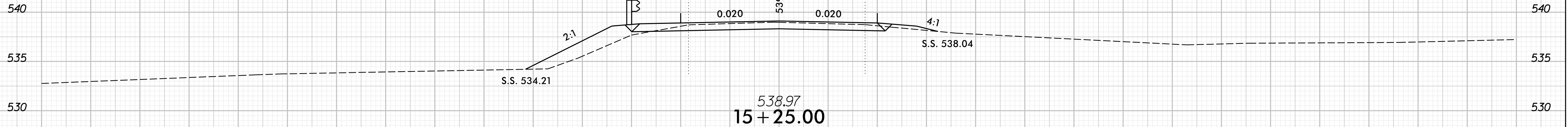

75 70 65 60 55 50 45 40 35 30 25 20 15 10 5 0 5 10 15 20 25 30 35 40 45 50 55 60 65 70 75

3/17/2017
S:\Projects\17BP\10.R\67\17BP-10R67_RDY_XPL.DGN
2:15:35 PM

8/23/99



| | |
|---------------------|-----------|
| PROJ. REFERENCE NO. | SHEET NO. |
| 17BP.10.R.67 | X-6 |

75 70 65 60 55 50 45 40 35 30 25 20 15 10 5 0 5 10 15 20 25 30 35 40 45 50 55 60 65 70 75

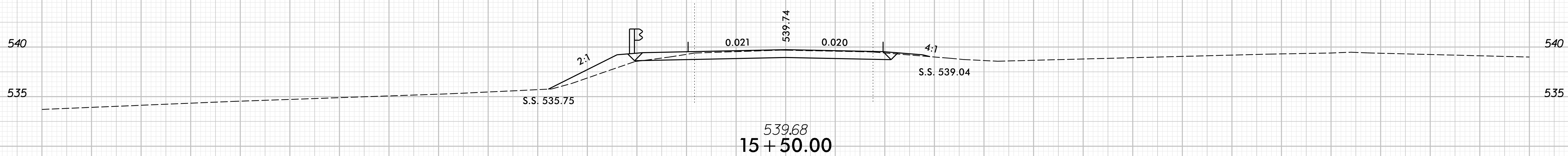
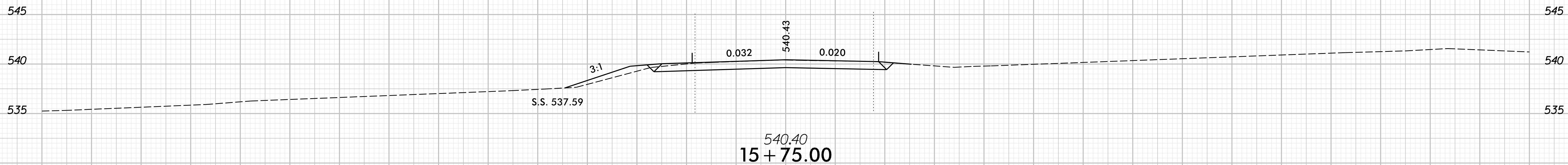
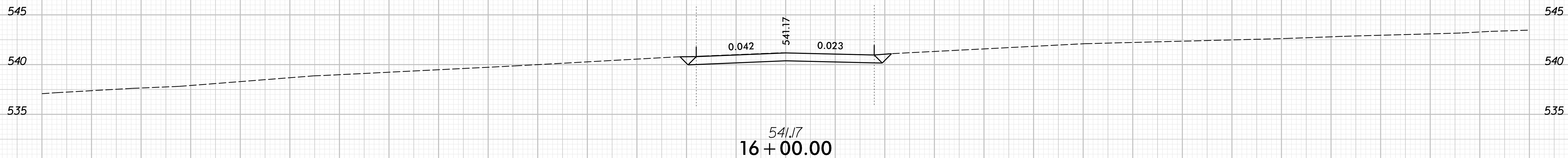

75 70 65 60 55 50 45 40 35 30 25 20 15 10 5 0 5 10 15 20 25 30 35 40 45 50 55 60 65 70 75

3/17/2017
S:\EWS\Projects\17BP-10R67\RDY_XPL.DGN