

STATE	PROJECT NO.	SHEET NO.	TOTAL SHEETS
N.C.	2024CPT.10.02.10041 2024CPT.10.02.20041 2024CPT.10.02.20042	1	
F.A. PROJECT NO.			

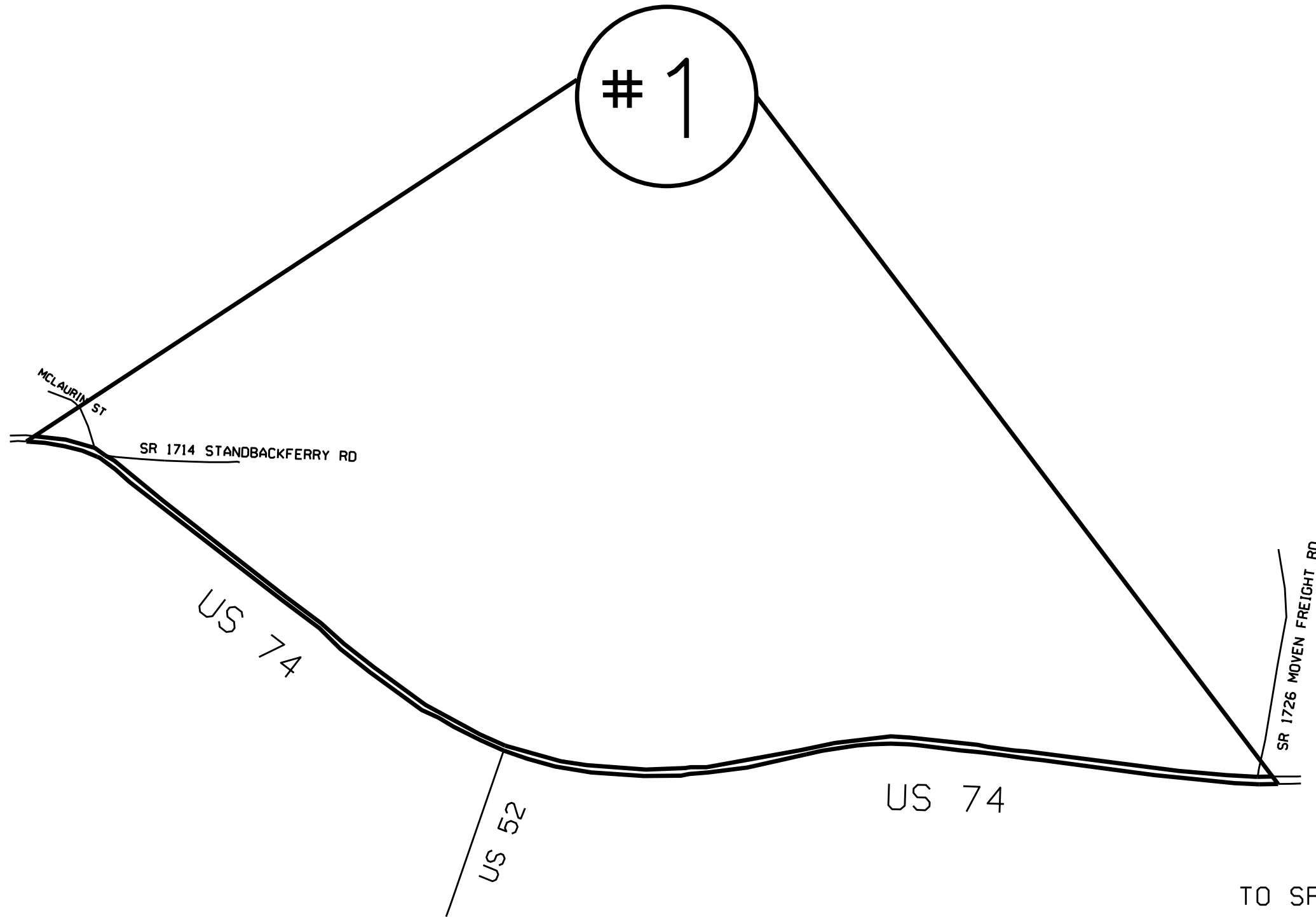

ENLARGED MUNICIPAL AND SUBURBAN AREAS
ANSON COUNTY
 NORTH CAROLINA
PREPARED BY THE
 NORTH CAROLINA DEPARTMENT OF TRANSPORTATION
 DIVISION OF HIGHWAYS - DIVISION 10 DISTRICT 3

MAP #1 US 74
 1.78 MILES EBL & WBL
 FROM MCLAURIN ST
 TO SR 1726 MORVEN FREIGHT LINE RD

STATE	PROJECT NO.	SHEET NO.	TOTAL SHEETS
N.C.	2024CPT.10.02.10041 2024CPT.10.02.20041 2024CPT.10.02.20042	2	
F.A. PROJECT NO.			

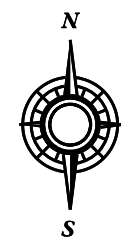
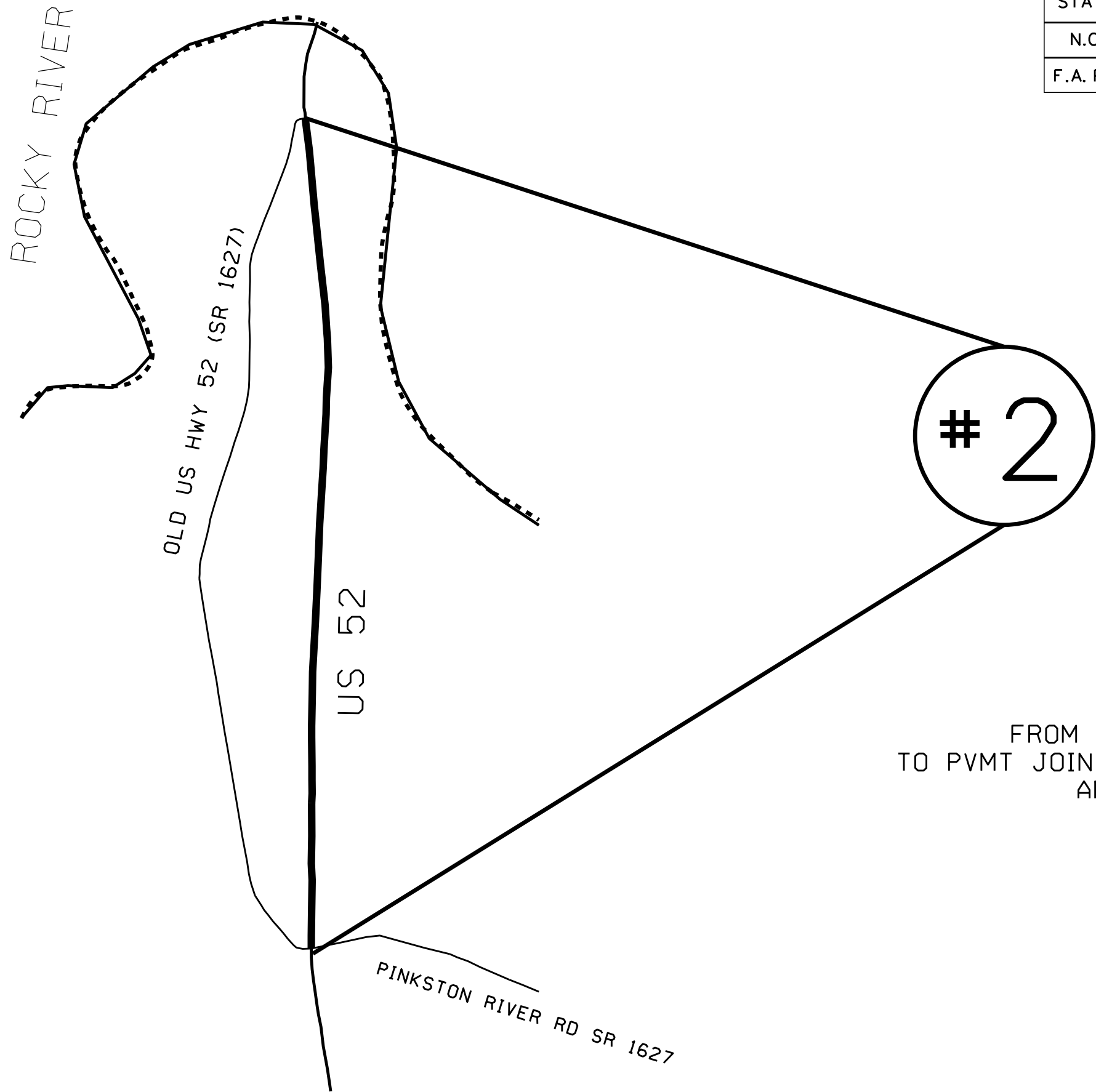

ENLARGED MUNICIPAL AND SUBURBAN AREAS
ANSON COUNTY
 NORTH CAROLINA
PREPARED BY THE
 NORTH CAROLINA DEPARTMENT OF TRANSPORTATION
 DIVISION OF HIGHWAYS - DIVISION 10 DISTRICT 3

MAP #2 US 52
 3.2 MILES
 FROM SR 1627 PINKSTON RIVER RD
 TO PVMT JOINT BETWEEN SR 1627 OLD US HWY 52
 AND ROCKY RIVER BRIDGE

STATE	PROJECT NO.	SHEET NO.	TOTAL SHEETS
N.C.	2024CPT.10.02.10041 2024CPT.10.02.20041 2024CPT.10.02.20042	3	
F.A. PROJECT NO.			



ENLARGED MUNICIPAL AND SUBURBAN AREAS
ANSON COUNTY
 NORTH CAROLINA
PREPARED BY THE
 NORTH CAROLINA DEPARTMENT OF TRANSPORTATION
 DIVISION OF HIGHWAYS - DIVISION 10 DISTRICT 3

3

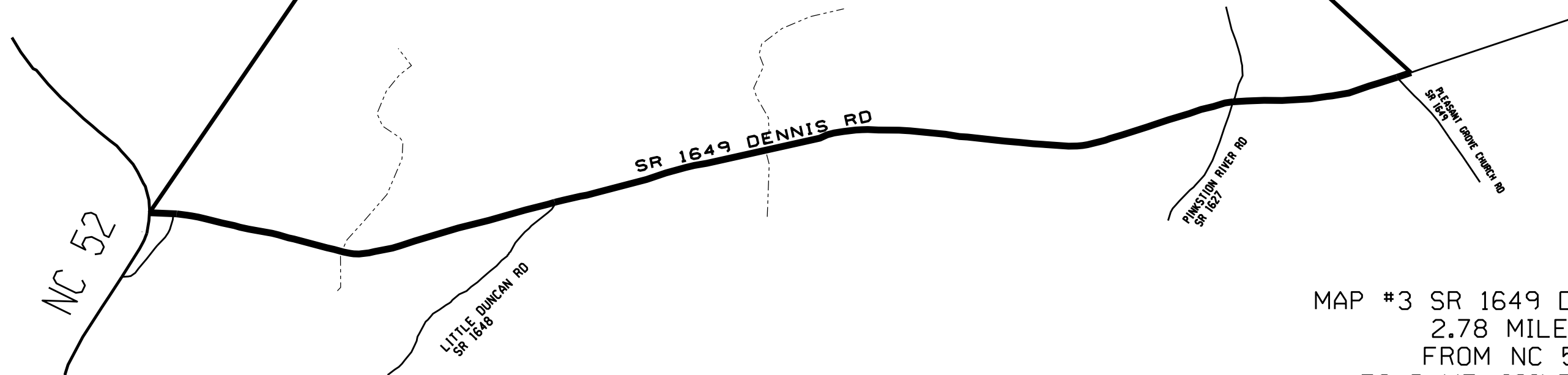

MAP #3 SR 1649 DENNIS RD
 2.78 MILES
 FROM NC 52
 TO PVMT JOINT PAST
 SR 1649 PLEASANT GROVE CHRUCH RD

STATE	PROJECT NO.	SHEET NO.	TOTAL SHEETS
N.C.	2024CPT.10.02.10041 2024CPT.10.02.20041 2024CPT.10.02.20042	4	
F.A. PROJECT NO.			

UNION COUNTY

OKEY HIGH RD
SR 1229

TICE ROAD
SR 1225

WHITE STORE RD
SR 1228

4



ENLARGED MUNICIPAL AND SUBURBAN AREAS
ANSON COUNTY
 NORTH CAROLINA
PREPARED BY THE
 NORTH CAROLINA DEPARTMENT OF TRANSPORTATION
 DIVISION OF HIGHWAYS - DIVISION 10 DISTRICT 3

MAP #4 SR 1225 TICE RD
 1.37 MILES
 FROM SR 1229 OKEY HIGH RD
 TO SR 1228 WHITE STORE ROAD

STATE	PROJECT NO.	SHEET NO.	TOTAL SHEETS
N.C.	2024CPT.10.02.10041 2024CPT.10.02.20041 2024CPT.10.02.20042	5	
F.A. PROJECT NO.			

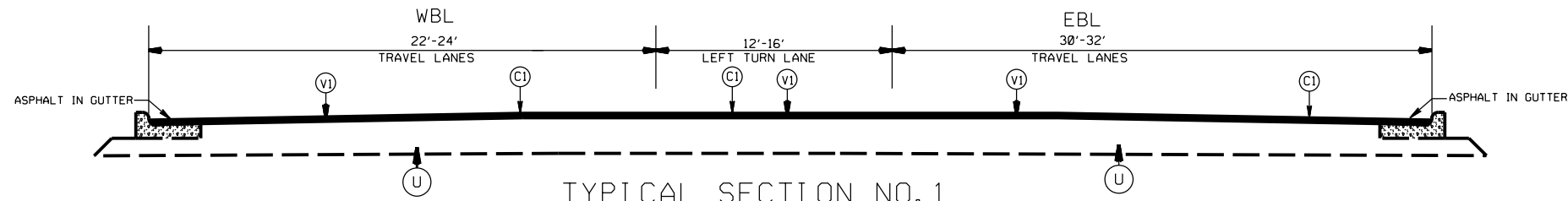

TYPICAL SECTION NO.1
US 74 (MAP 1)
APPROX. STA. 10+00 TO 10+40

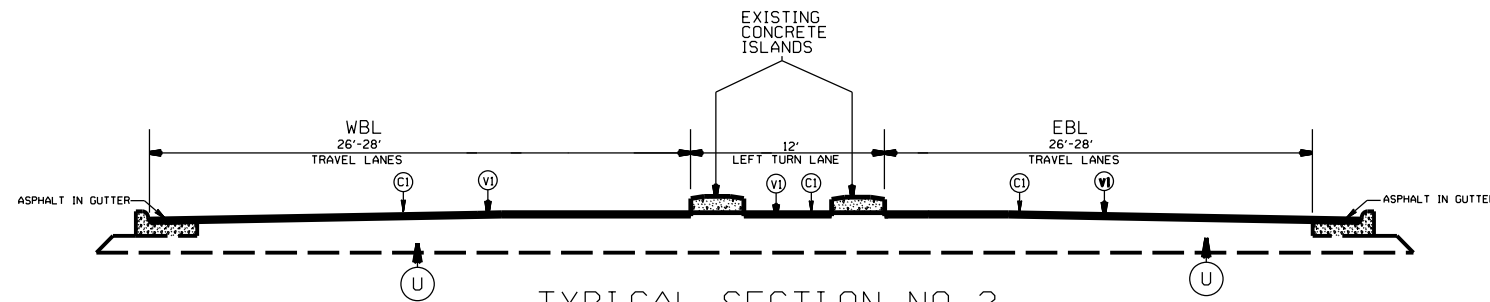

TYPICAL SECTION NO.2
US 74 (MAP 1)
APPROX. STA. 10+40 TO 15+87

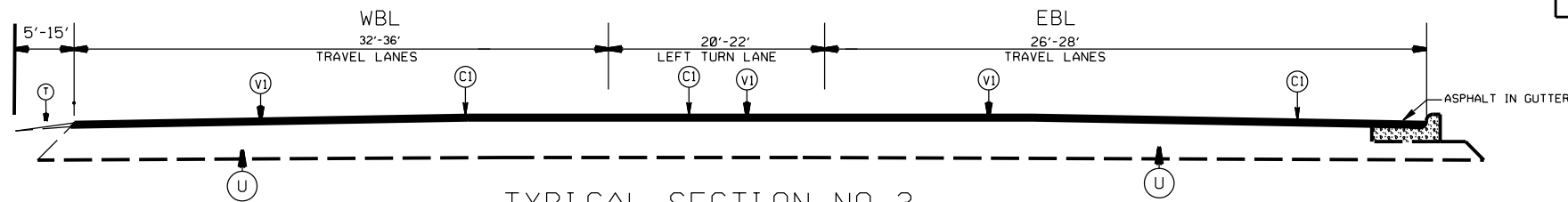

TYPICAL SECTION NO.3
US 74 (MAP 1)
APPROX. STA. 15+87 TO 16+75

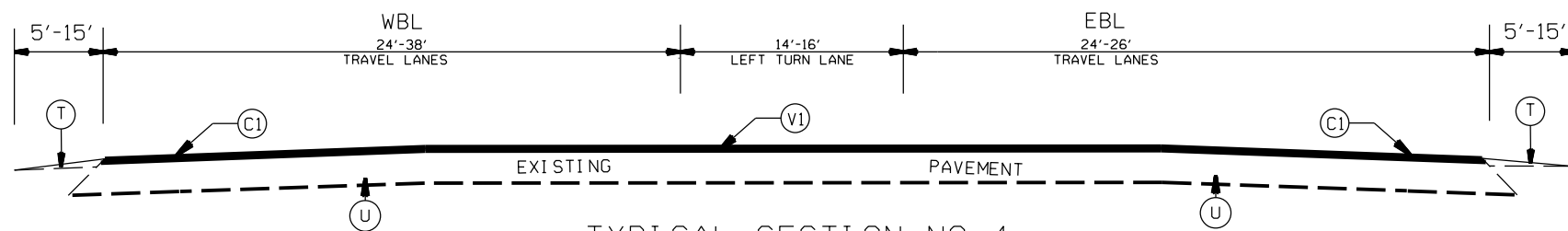

TYPICAL SECTION NO.4
US 74 (MAP 1)
APPROX. STA. 16+75 TO 18+48

PAVEMENT SCHEDULE

(C1)	PROP. APPROX. 2.0" ASPHALT CONC. SURFACE COURSE, TYPE S9.5C, AT AN AVERAGE RATE OF 224 LBS. PER SQ. YD.
(C2)	PROP. APPROX. 1.5" ASPHALT CONC. SURFACE COURSE, TYPE S9.5C, AT AN AVERAGE RATE OF 168 LBS. PER SQ. YD.
(F1)	PROP. ASPHALT SURFACE TREATMENT, TRIPLE SEAL, (SEE S. P. FOR AGGREGATE TYPE.)
(J1)	PROP. 8" AGGREGATE BASE COURSE (SEE S.P. FOR TRENCHING FOR ABC)
(T1)	SHOULDER RECONSTRUCTION
(U)	EXISTING PAVEMENT
(V1)	MILLING OF EXISTING PAVEMENT, 2.0" DEPTH.
(Z)	FULL DEPTH RECLAMATION

2024
ANSON COUNTY RESURFACING

SCALE	-NA-
DATE	9/1
DWG. BY	AJB
DESIGN BY	AJB
APPROVED	



REVISIONS	

STATE	PROJECT NO.	SHEET NO.	TOTAL SHEETS
N.C.	2024CPT.10.02.10041 2024CPT.10.02.20041 2024CPT.10.02.20042	6	
F.A. PROJECT NO.			

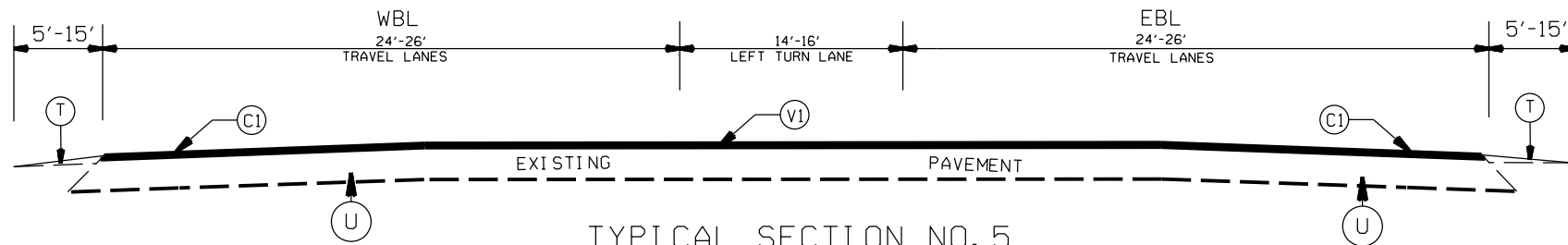

TYPICAL SECTION NO. 5
US 74 (MAP 1)
APPROX. STA. 18+48 TO 46+86

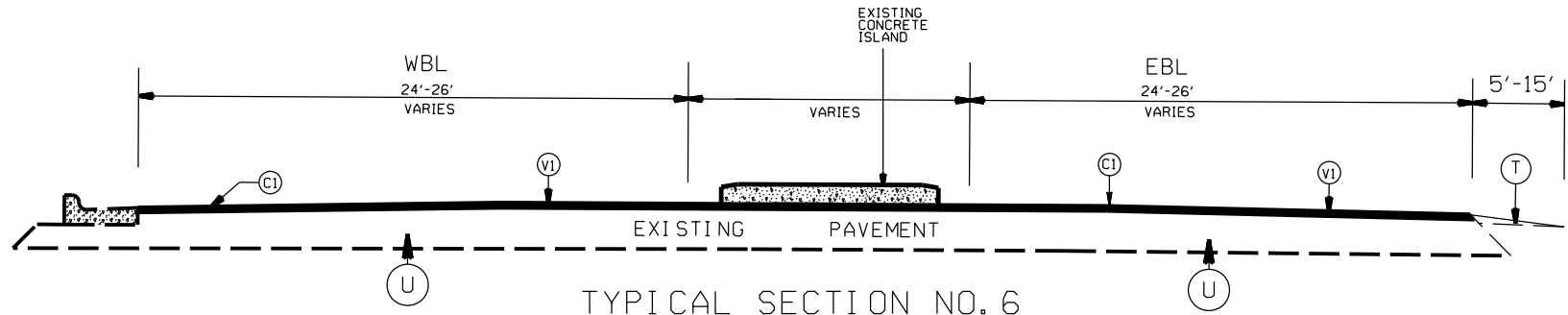

TYPICAL SECTION NO. 6
US 74 (MAP 1)
APPROX. STA. 49+83 TO 46+86

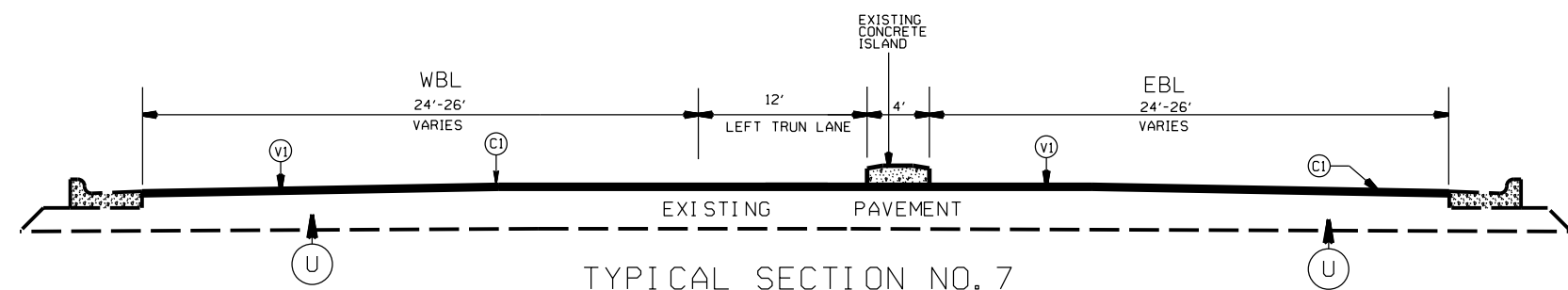

TYPICAL SECTION NO. 7
US 74 MAP 1
APPROX. STA. 51+66 TO 49+83

PAVEMENT SCHEDULE

(C1)	PROP. APPROX. 2.0" ASPHALT CONC. SURFACE COURSE, TYPE S9.5C, AT AN AVERAGE RATE OF 224 LBS. PER SQ. YD.
(C2)	PROP. APPROX. 1.5" ASPHALT CONC. SURFACE COURSE, TYPE S9.5C, AT AN AVERAGE RATE OF 168 LBS. PER SQ. YD.
(F1)	PROP. ASPHALT SURFACE TREATMENT, TRIPLE SEAL, (SEE S.P. FOR AGGREGATE TYPE.)
(J1)	PROP. 8" AGGREGATE BASE COUSRE (SEE S.P. FOR TRENCHING FOR ABC)
(T1)	SHOULDER RECONSTRUCTION
(U)	EXISTING PAVEMENT
(V1)	MILLING OF EXISTING PAVEMENT, 2.0" DEPTH.
(Z)	FULL DEPTH RECLAMATION

2024
ANSON COUNTY RESURFACING

SCALE	DATE	DESIGN BY	APPROVED	REVISIONS
-NA-	9/1	AJB		
		AJB		



STATE	PROJECT NO.	SHEET NO.	TOTAL SHEETS
N.C.	2024CPT.10.02.10041 2024CPT.10.02.20041 2024CPT.10.02.20042	7	
F.A. PROJECT NO.			

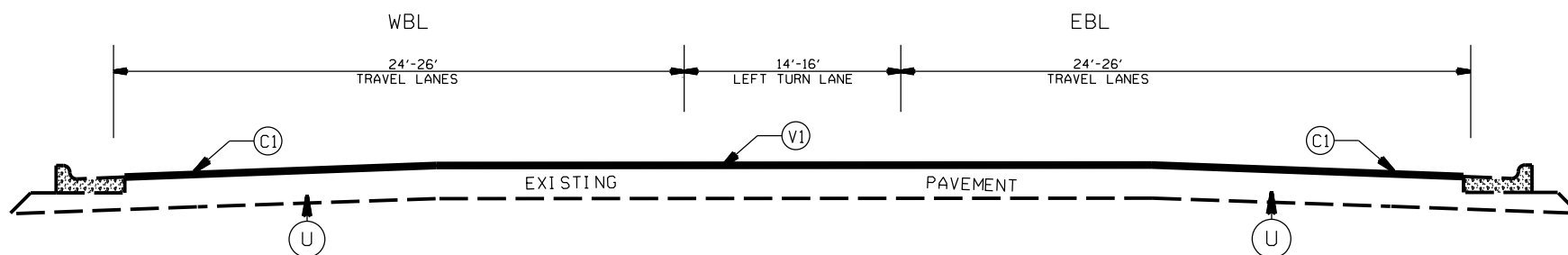

TYPICAL SECTION NO. 8
US 74 (MAP 1)
APPROX. STA. 74+07 TO 103+98
APPROX. STA. 51+66 TO 69+47

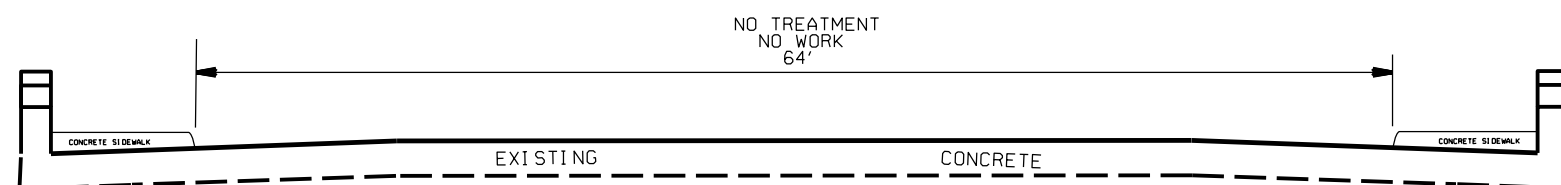

TYPICAL SECTION NO. 9
US 74 (MAP 1)
BRIDGE (NO TREATMENT)
APPROX. STA. 69+47 TO 74+07

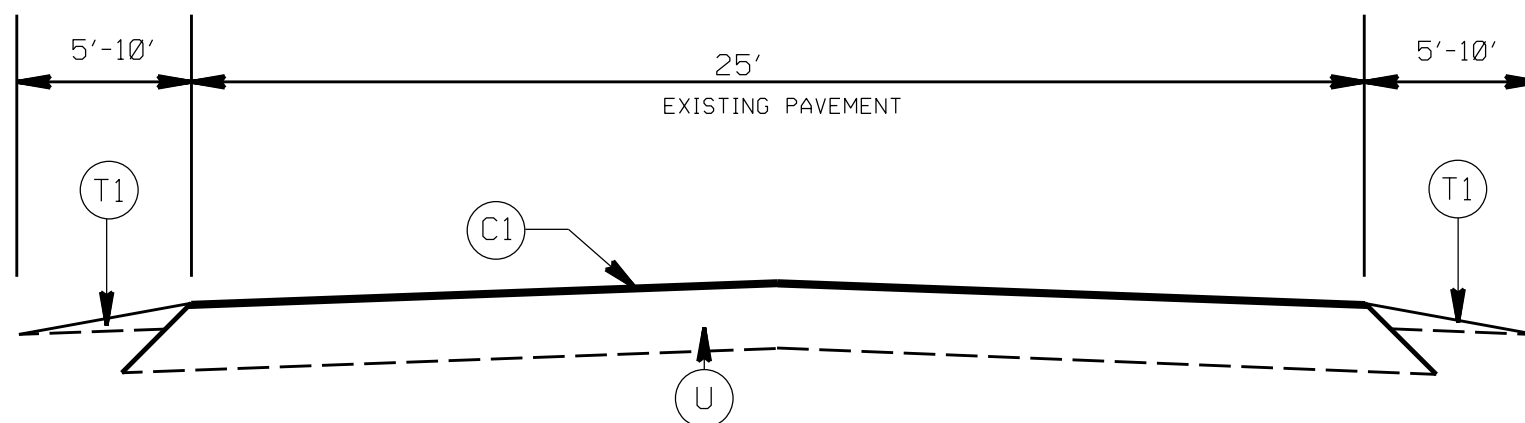

TYPICAL SECTION NO. 10
US 52 (MAP 2)

PAVEMENT SCHEDULE

(C1)	PROP. APPROX. 2.0" ASPHALT CONC. SURFACE COURSE, TYPE S9.5C, AT AN AVERAGE RATE OF 224 LBS. PER SQ. YD.
(C2)	PROP. APPROX. 1.5" ASPHALT CONC. SURFACE COURSE, TYPE S9.5C, AT AN AVERAGE RATE OF 168 LBS. PER SQ. YD.
(F1)	PROP. ASPHALT SURFACE TREATMENT, TRIPLE SEAL, (SEE S.P. FOR AGGREGATE TYPE.)
(J1)	PROP. 8" AGGREGATE BASE COURSE (SEE S.P. FOR TRENCHING FOR ABC)
(T1)	SHOULDER RECONSTRUCTION
(U)	EXISTING PAVEMENT
(V1)	MILLING OF EXISTING PAVEMENT, 2.0" DEPTH.
(Z)	FULL DEPTH RECLAMATION

2024
ANSON COUNTY RESURFACING

SCALE	DATE	DWG. BY	DESIGN BY	APPROVED	REVISIONS
-NA-	9/1	AJB	AJB		



STATE	PROJECT NO.	SHEET NO.	TOTAL SHEETS
N.C.	2024CPT.10.02.10041 2024CPT.10.02.20041 2024CPT.10.02.20042	8	
F.A. PROJECT NO.			

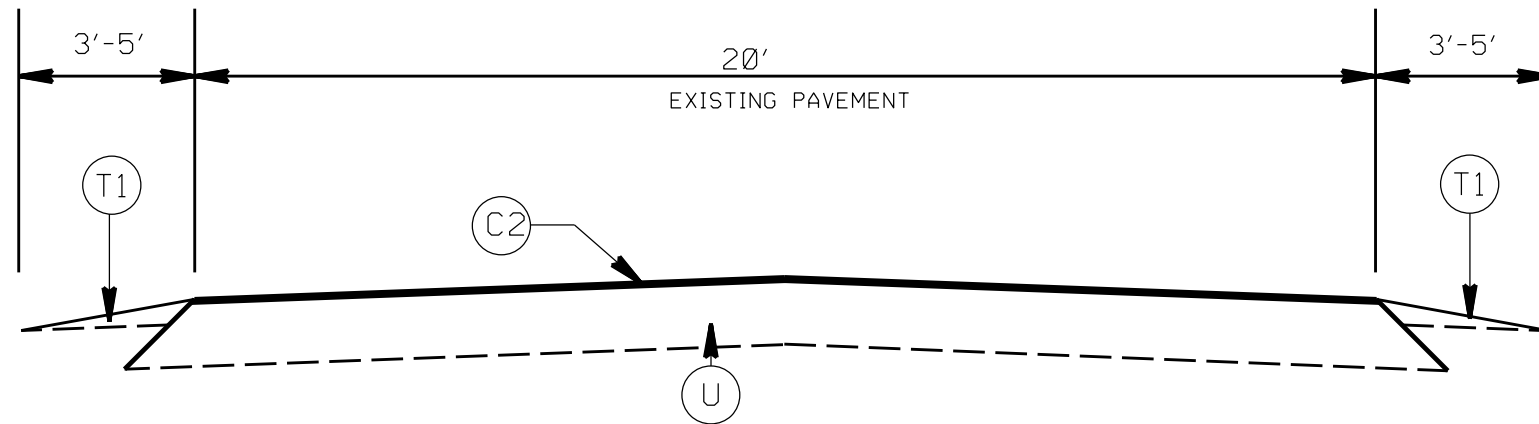

TYPICAL SECTION NO. 11
SR 1649 DENNIS RD (MAP 3)

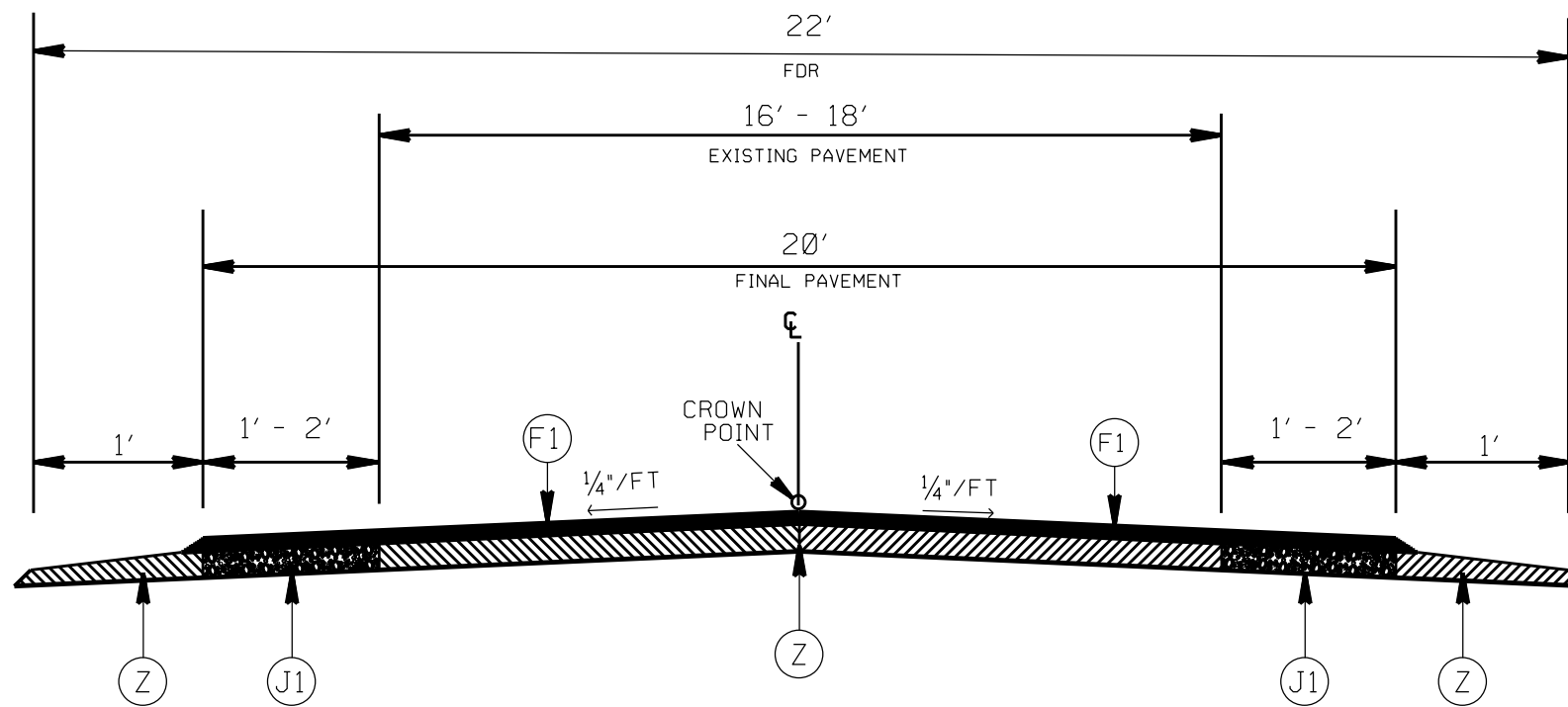

TYPICAL SECTION NO. 12
SR 1225 TICE ROAD (MAP 4)
APPROX. STA. 10+00 TO 41+06

PAVEMENT SCHEDULE

(C1)	PROP. APPROX. 2.0" ASPHALT CONC. SURFACE COURSE, TYPE S9.5C, AT AN AVERAGE RATE OF 224 LBS. PER SQ. YD.
(C2)	PROP. APPROX. 1.5" ASPHALT CONC. SURFACE COURSE, TYPE S9.5C, AT AN AVERAGE RATE OF 168 LBS. PER SQ. YD.
(F1)	PROP. ASPHALT SURFACE TREATMENT, TRIPLE SEAL, (SEE S.P. FOR AGGREGATE TYPE.)
(J1)	PROP. 8" AGGREGATE BASE COURSE (SEE S.P. FOR TRENCHING FOR ABC)
(T1)	SHOULDER RECONSTRUCTION
(U)	EXISTING PAVEMENT
(V1)	MILLING OF EXISTING PAVEMENT, 2.0" DEPTH.
(Z)	FULL DEPTH RECLAMATION

2024
ANSON COUNTY RESURFACING

SCALE -NA-
DATE 9/1
DWG. BY AJB
DESIGN BY AJB
APPROVED



REVISIONS	

STATE	PROJECT NO.	SHEET NO.	TOTAL SHEETS
N.C.	2024CPT.10.02.10041 2024CPT.10.02.20041 2024CPT.10.02.20042	9	
F.A. PROJECT NO.			

PAVEMENT SCHEDULE

(C1)	PROP. APPROX. 2.0" ASPHALT CONC. SURFACE COURSE, TYPE S9.5C, AT AN AVERAGE RATE OF 224 LBS. PER SQ. YD.
(C2)	PROP. APPROX. 1.5" ASPHALT CONC. SURFACE COURSE, TYPE S9.5C, AT AN AVERAGE RATE OF 168 LBS. PER SQ. YD.
(F1)	PROP. ASPHALT SURFACE TREATMENT, TRIPLE SEAL, (SEE S. P. FOR AGGREGATE TYPE.)
(J1)	PROP. 8" AGGREGATE BASE COURSE (SEE S.P. FOR TRENCHING FOR ABC)
(T1)	SHOULDER RECONSTRUCTION
(U)	EXISTING PAVEMENT
(V1)	MILLING OF EXISTING PAVEMENT, 2.0" DEPTH.
(Z)	FULL DEPTH RECLAMATION

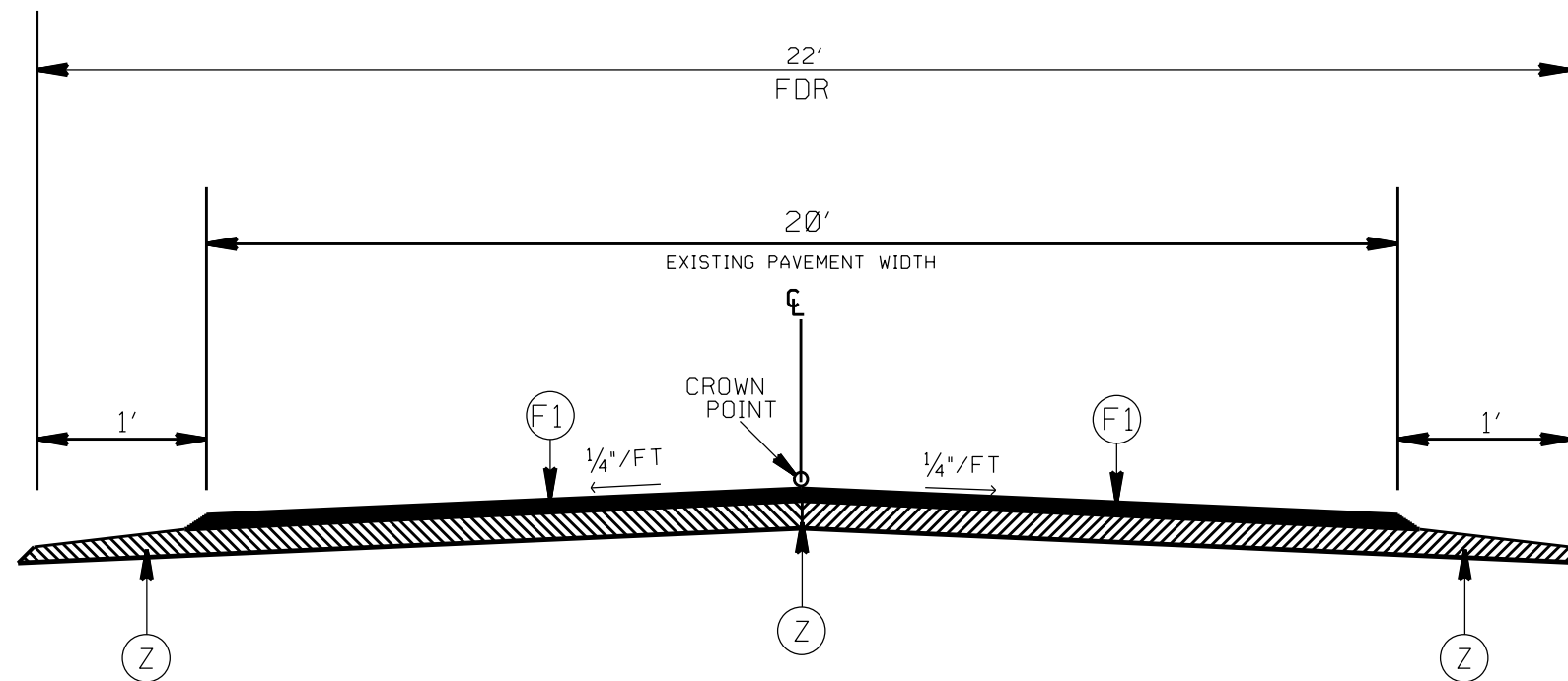

TYPICAL SECTION NO. 13
SR 1225 TICE ROAD (MAP 4)
APPROX STA. 41+06 TO 81+81

2024 ANSON COUNTY RESURFACING		
SCALE	-NA-	
DATE	9/1	
DWG. BY	AJB	
DESIGN BY	AJB	
APPROVED		REVISIONS

STATE	PROJECT NO.	SHEET NO.	TOTAL SHEETS
N.C.	2024CPT.10.02.10041 2024CPT.10.02.20041 2024CPT.10.02.20042	10	
F.A. PROJECT NO.			

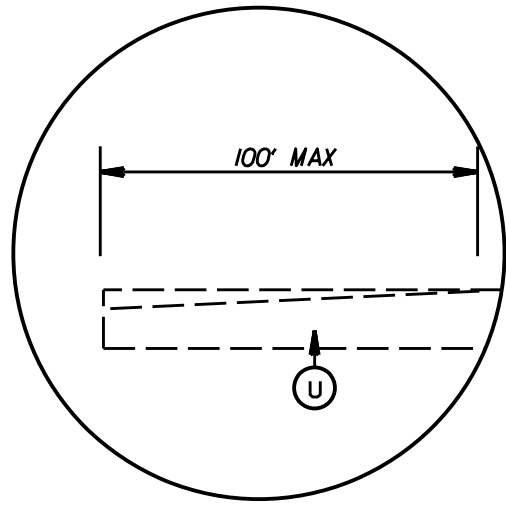

DETAIL FOR INCIDENTAL MILLING (0" TO 2.0")

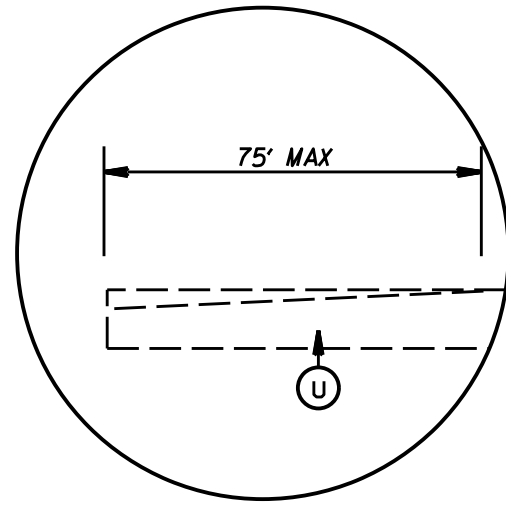

DETAIL FOR INCIDENTAL MILLING (0" TO 1.5")

PAVEMENT SCHEDULE

(C1)	PROP. APPROX. 2.0" ASPHALT CONC. SURFACE COURSE, TYPE S9.5C, AT AN AVERAGE RATE OF 224 LBS. PER SQ. YD.
(C2)	PROP. APPROX. 1.5" ASPHALT CONC. SURFACE COURSE, TYPE S9.5C, AT AN AVERAGE RATE OF 168 LBS. PER SQ. YD.
(F1)	PROP. ASPHALT SURFACE TREATMENT, TRIPLE SEAL, (SEE S. P. FOR AGGREGATE TYPE.)
(J1)	PROP. 8" AGGREGATE BASE COURSE (SEE S.P. FOR TRENCHING FOR ABC)
(T1)	SHOULDER RECONSTRUCTION
(U)	EXISTING PAVEMENT
(V1)	MILLING OF EXISTING PAVEMENT, 2.0" DEPTH.
(Z)	FULL DEPTH RECLAMATION

PATCHING DETAIL

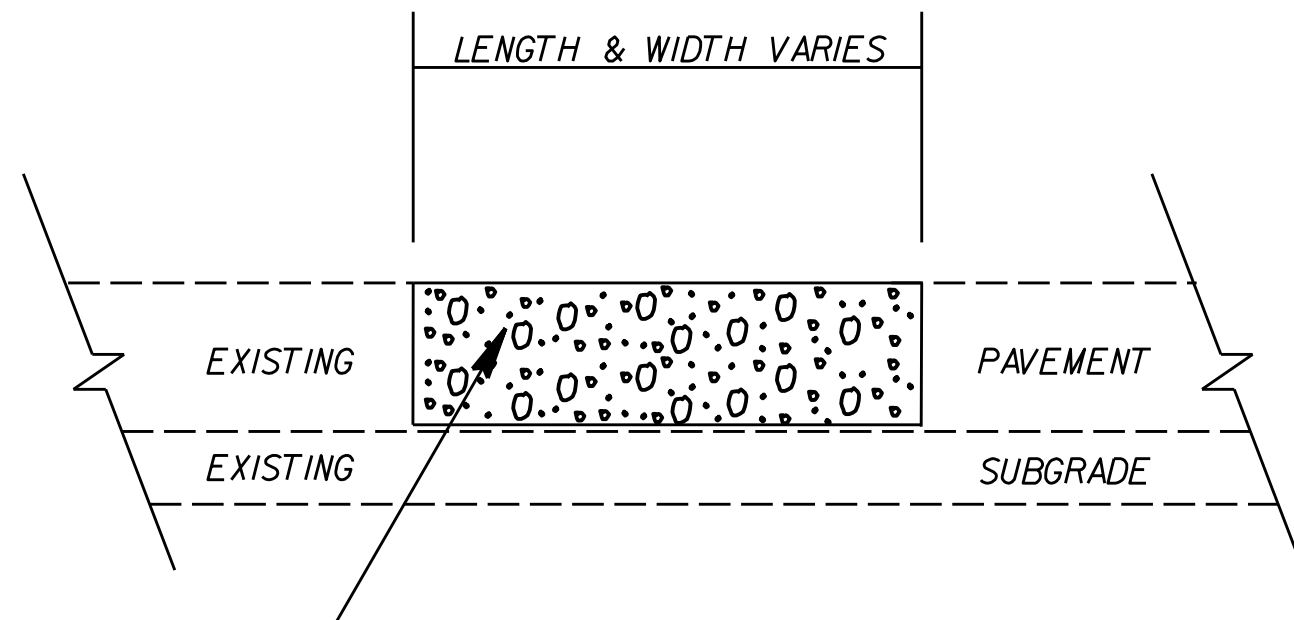

RATE IS VARIABLE AND SHALL BE AS DIRECTED BY THE ENGINEER. ASPHALT TYPE 119.0C SHALL BE PLACED.

2024 ANSON COUNTY RESURFACING			
SCALE	-NA-		REVISIONS
DATE	9/1		
DWG. BY	AJB		
DESIGN BY	AJB		
APPROVED			

STATE	PROJECT NO.	SHEET NO.	TOTAL SHEETS
N.C.	2024CPT.10.02.10041 2024CPT.10.02.20041 2024CPT.10.02.20042	11	
F.A. PROJECT NO.			

NOTES:

1. ON MAP 1, DO NOT PLACE ASPHALT ON CONCRETE BRIDGE.
2. DEPTH OF PATCHING WILL BE AS DIRECTED BY THE ENGINEER
3. SHOULDER RECONSTRUCTION WILL BE AS DIRECTED BY THE ENGINEER
4. WIDENING WITH ABC, ON FULL DEPTH RECLAMATION MAP 4, TO BE DONE PRIOR TO FULL DEPTH RECLAMATION

2024
ANSON COUNTY RESURFACING

SCALE	DATE	DWG. BY	DESIGN BY	APPROVED	REVISIONS
-NA-	9/1	AJB	AJB		



STATE	PROJECT NO.	SHEET NO.	TOTAL SHEETS
N.C.	2024CPT.10.02.10041 2024CPT.10.02.20041 2024CPT.10.02.20042	12	
F.A. PROJECT NO.			

NOTES:

- 1) DETAIL DOES NOT APPLY TO OGAFCC AND ULTRA-THIN BONDED WEARING COURSE.
- 2) BACKFILL SHOULDER WITH APPROVED MATERIAL.
- 3) THE SHOULDER WEDGE DEVICE MAY BE DISENGAGED AT PAVED DRIVEWAYS AND SIDE STREETS.

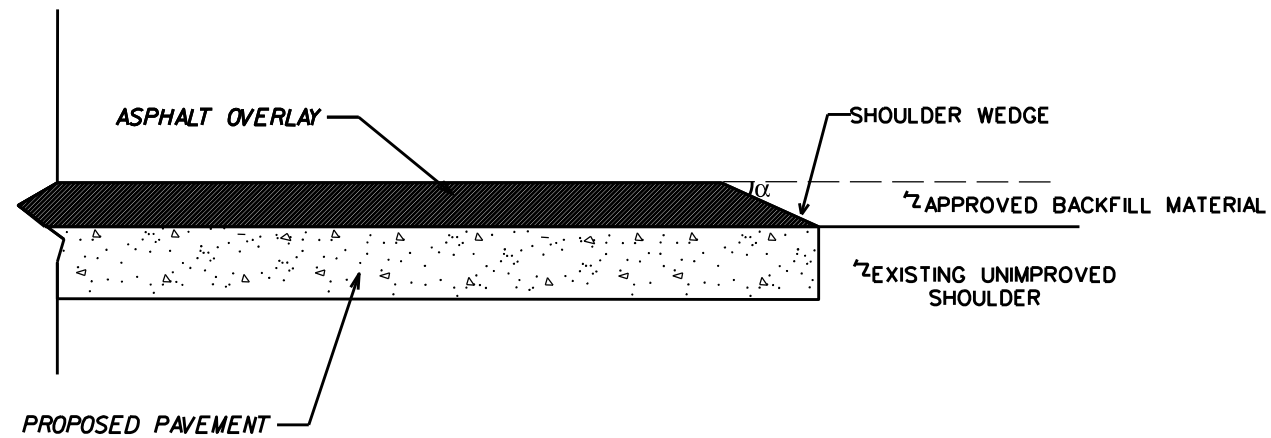

SHOULDER WEDGE DETAIL

(RESURFACING PROJECTS W/ WIDENING OR WITH EXISTING PAVED SHOULDER HAVING NO DROPOFFS)

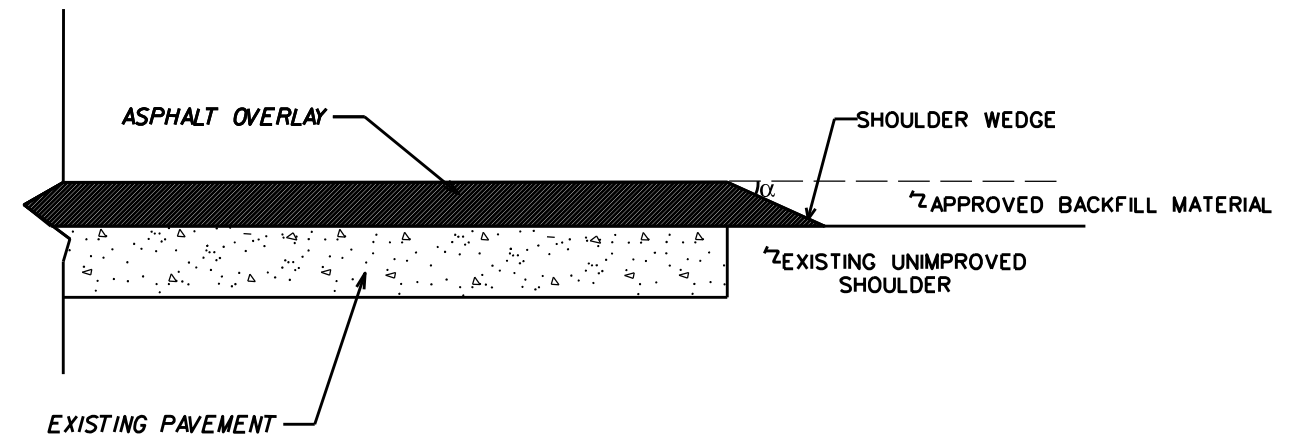

SHOULDER WEDGE DETAIL

(RESURFACING PROJECTS W/ NO WIDENING)

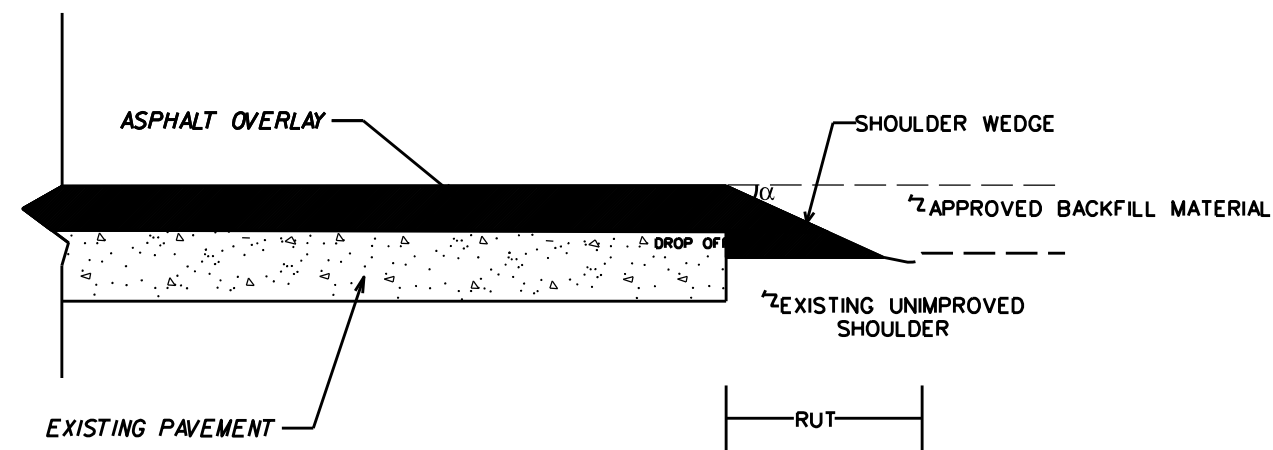

SHOULDER WEDGE DETAIL
(RESURFACING ADJACENT TO RUTTED SHOULDER)

$\alpha = 30$ DEGREES

SHOULDER WEDGE DETAILS		
SCALE	-1A-	REVISIONS
DATE	9/1	
DWG. BY	AJB	
DESIGN BY	AJB	
APPROVED		



INTERSECTION EMULSION PLACEMENT TWO LANE TWO WAY ROADWAY

STATE	PROJECT NO.	SHEET NO.	TOTAL SHEETS
N.C.	2024cpt.10.02.10041 2024cpt.10.02.20041 2024cpt.10.02.20042	13	
F.A. PROJECT NO.			

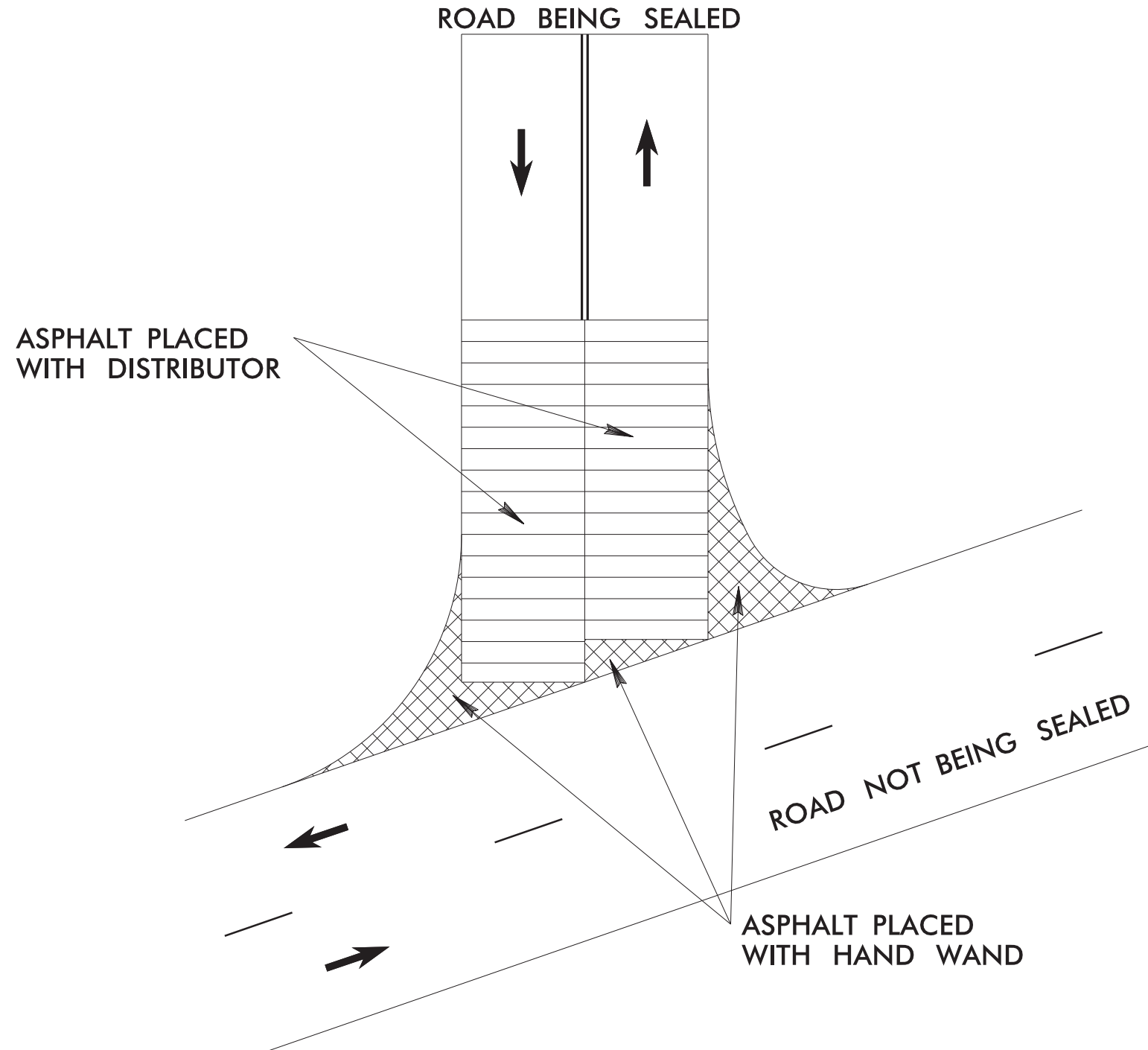

LEGEND

- DIRECTION OF TRAFFIC FLOW
- SKIP LINES
- DOUBLE YELLOW LINES

<i>INTERSECTION EMULSION PLACEMENT</i>		
SCALE	N/A	REVISIONS
DATE	9-2019	
DWG. BY	TBL	
DESIGN BY	TBL	
APPROVED	TWB	



WATTLE WITH POLYACRYLAMIDE DETAIL

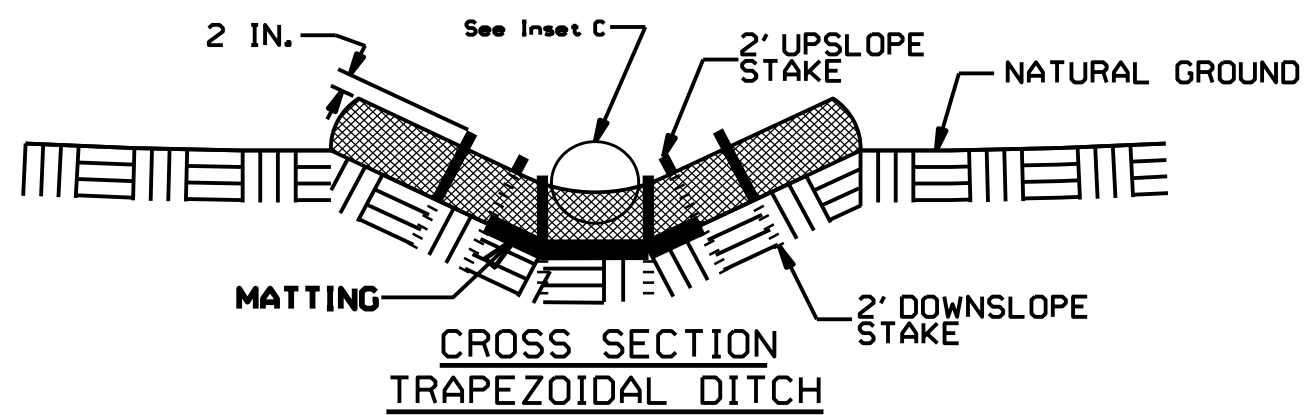
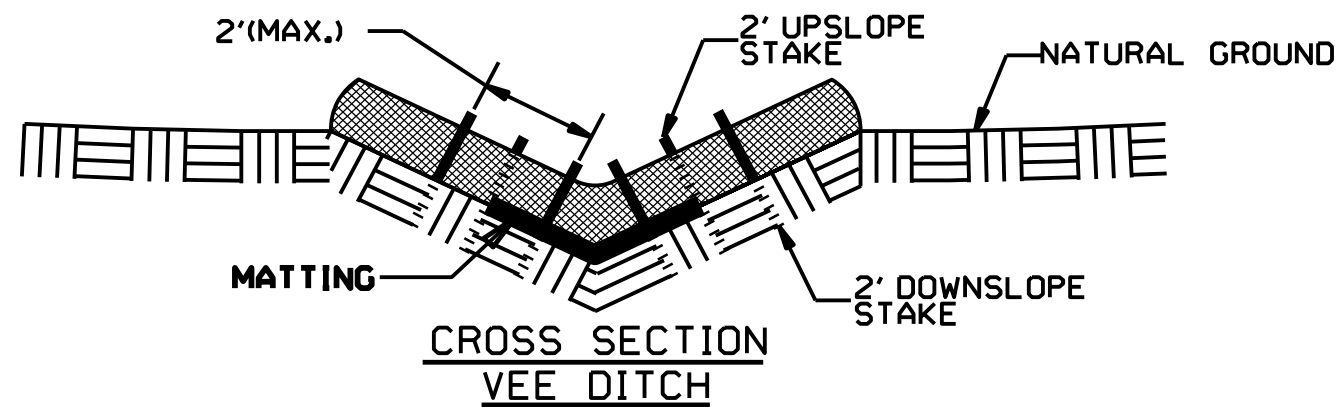
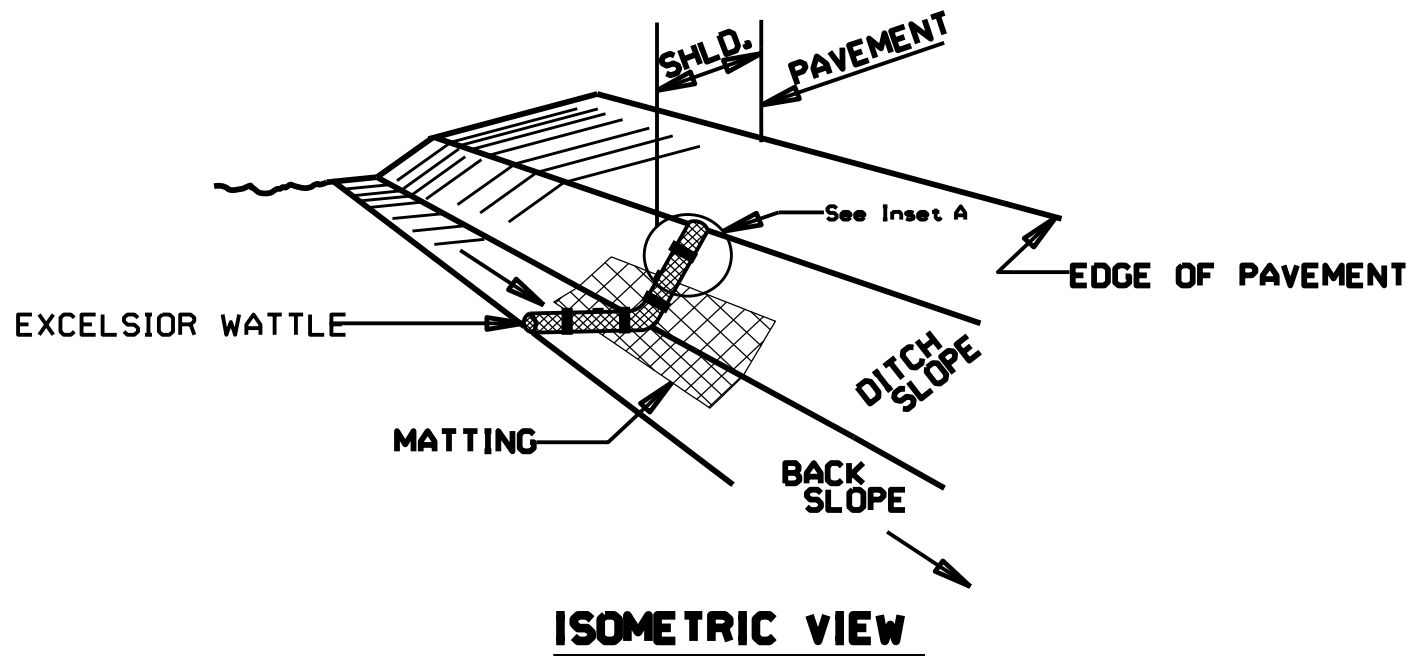

NOTES:

USE MINIMUM 12 IN. DIAMETER EXCELSIOR WATTLE.

USE 2 FT. WOODEN STAKES WITH A 2 IN. BY 2 IN. CROSS SECTION.

INSTALL A MINIMUM OF 2 UPSLOPE STAKES AND 4 DOWNSLOPE STAKES AT AN ANGLE TO WEDGE WATTLE TO BOTTOM OF DITCH.

PROVIDE STAPLES MADE OF 0.125 IN. DIAMETER STEEL WIRE FORMED INTO A U SHAPE NOT LESS THAN 12" IN LENGTH.

INSTALL STAPLES APPROXIMATELY EVERY 1 LINEAR FOOT ON BOTH SIDES OF WATTLE AND AT EACH END TO SECURE IT TO THE SOIL.

INSTALL MATTING IN ACCORDANCE WITH SECTION 1631 OF THE STANDARD SPECIFICATIONS.

PRIOR TO POLYACRYLAMIDE (PAM) APPLICATION, OBTAIN A SOIL SAMPLE FROM PROJECT LOCATION, AND FROM OFFSITE MATERIAL, AND ANALYZE FOR APPROPRIATE PAM FLOCCULANT TO BE APPLIED TO EACH WATTLE.

INITIALLY APPLY 3.5 OUNCES OF ANIONIC OR NEUTRALLY CHARGED POLYACRYLAMIDE (PAM) OVER WATTLE WHERE WATER WILL FLOW AND AFTER EVERY RAINFALL EVENT THAT IS EQUAL TO OR EXCEEDS 0.50 IN.

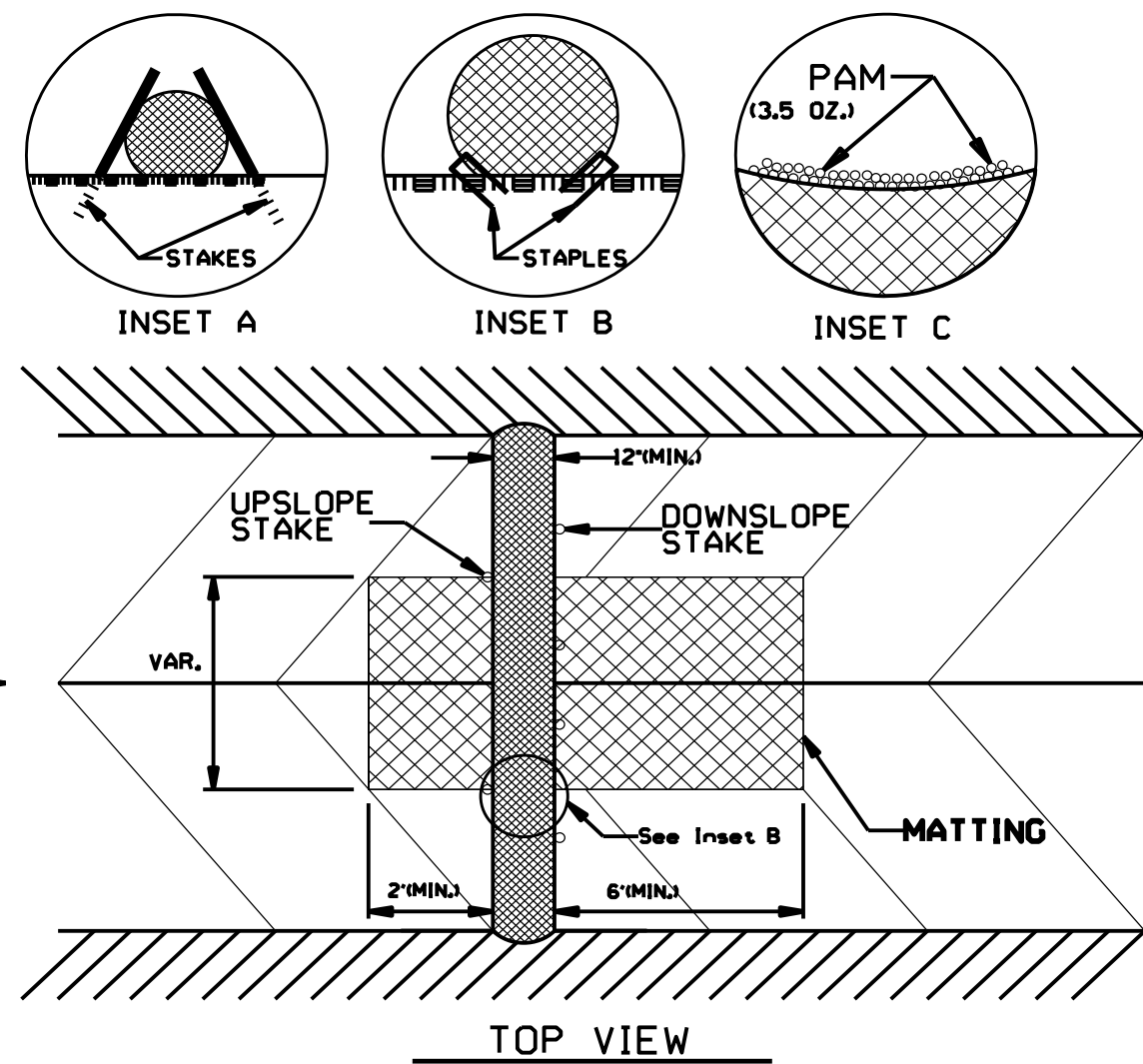

NOTES: LESS THAN 5' - 10' UNDISTURBED BUFFER FROM ROW, DITCHLINE, WATER FEATURE, OR DRAINAGE INLET, ADD BMP.

BMP OPTIONS: WATTLE OR SILT FENCE

<5' - 10' UNDISTURBED BUFFER ADD BMP

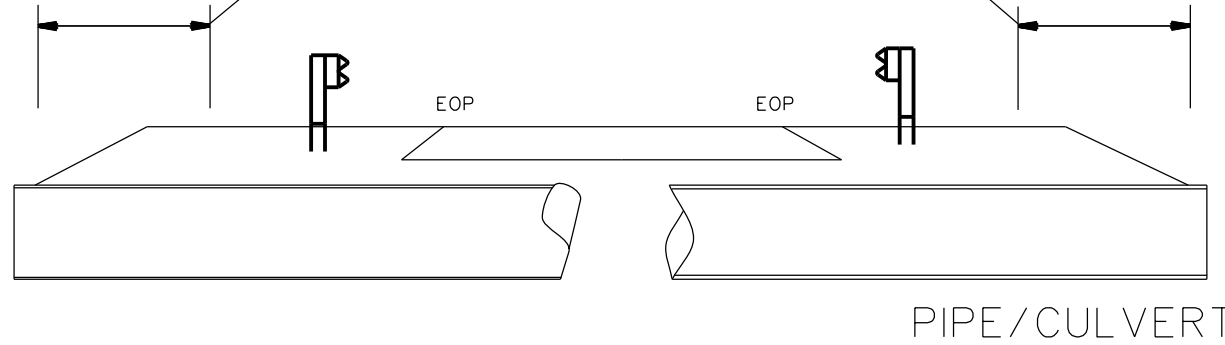

PIPE/CULVERT

STATE	PROJECT NO.	SHEET NO.	TOTAL SHEETS
N.C.	2024CPT.10.02.10041 2024CPT.10.02.20041 2024CPT.10.02.20042	EC2	
F.A. PROJECT NO.			

<5' - 10' UNDISTURBED BUFFER FROM JURISDICTIONAL FEATURE ADD BMP

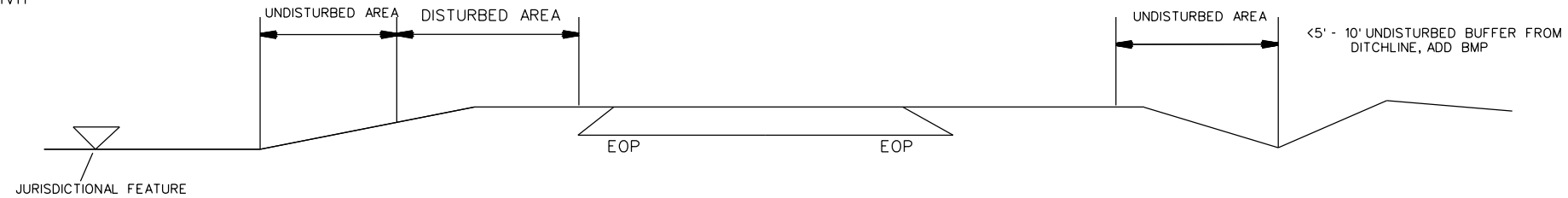

USE BMP'S IF SHOULDERS AND/OR FRONTSLOPES AND/OR DITCHLINE AND/OR BACKSLOPES ARE DISTURBED

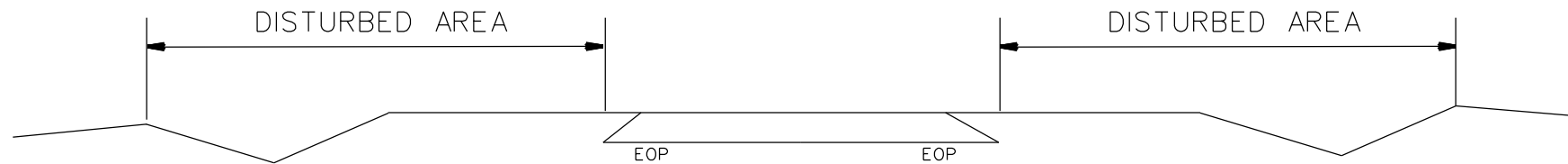

<5' - 10' UNDISTURBED BUFFER FROM INLET, ADD WATTLE

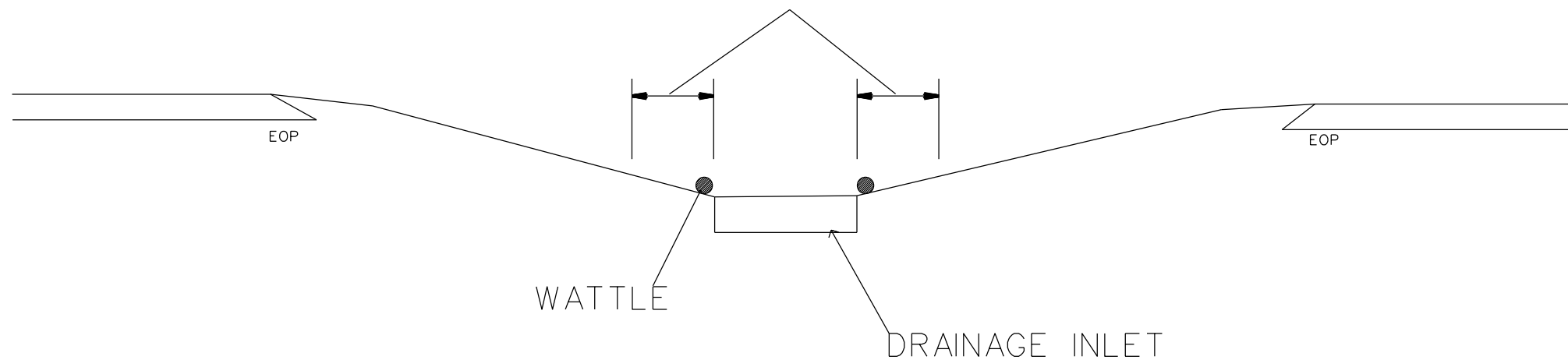

EROSION CONTROL DETAIL

SCALE	-NA-		REVISIONS
DATE	9/1		
DWG. BY	AJB		
DESIGN BY	AJB		
APPROVED			

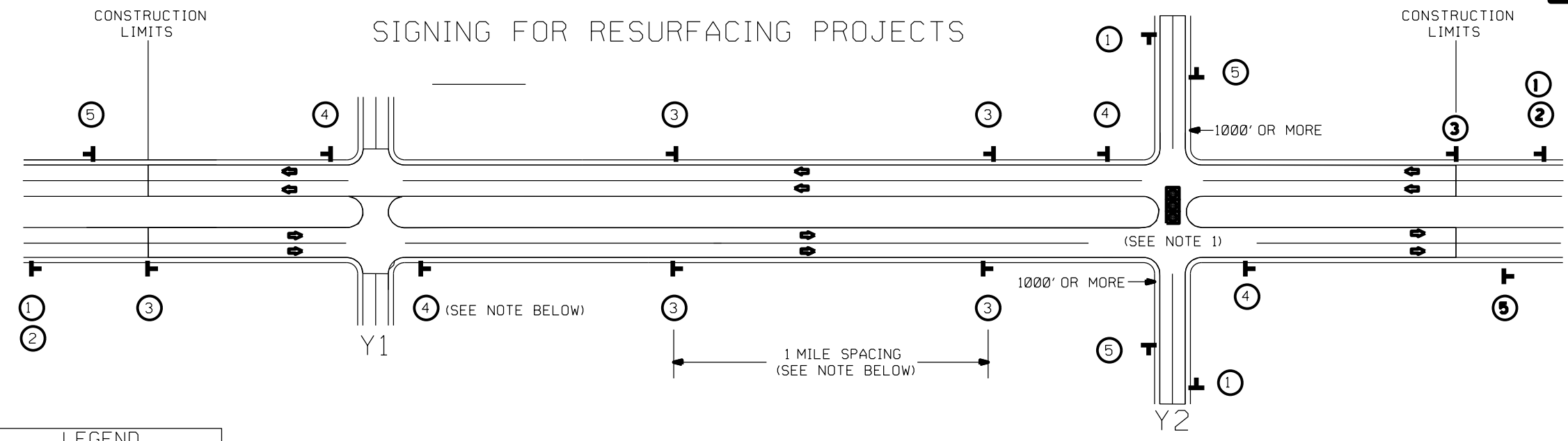

LEGEND	
T	STATIONARY SIGN
→	DIRECTION OF TRAFFIC FLOW

MAINLINE (-L-) SIGNING

-Y- LINE SIGNING

SIGNING NOTES AND PLACEMENT PER DIRECTION	1	ROAD WORK AHEAD	PLACE 1000' PRIOR TO BEGINNING OF CONSTRUCTION LIMITS. ONLY USED ON -Y- LINES IF RESURFACING LIMITS EXTEND 1000' ALONG -Y- LINE.
	2	NEXT XX MIL	#2 SIGN ONLY USED WHEN RESURFACING LIMITS ARE 2 OR MORE MILES IN LENGTH. ROUND UP TO NEXT WHOLE NUMBER.(NO FRACTIONAL OR DECIMAL NUMBERS)
	3	LOW/SOFT SHOULDER	PLACE INITIALLY AT THE CONSTRUCTION LIMITS AND SPACED 1 MILE APART THEREAFTER. IF NO -Y- LINES EXIST, PLACE 2ND SET 1/2 MILE FROM THE CONSTRUCTION LIMITS AND THEN SPACE 1 MILE THEREAFTER.
	4	ROAD UNDER CONST	THESE ARE FOR -Y- LINES THAT ARE "THROUGH" ROADWAYS. DEAD END AND SUBDIVISION ROADS ARE NOT "THROUGH" ROADWAYS. INSTALL 500' +/- FROM EACH -Y- LINE APPROACH AS SHOWN ABOVE. FOR MULTIPLE -Y- LINES THAT ARE SEPARATED BY 0.25 MILES OR LESS, TREAT AS A SINGLE UNIT AND INSTALL WITHIN 500' OF EACH APPROACH. A MAXIMUM OF 2 SIGN SETS PER MILE. DO NOT INSTALL WHEN -Y- LINES ARE WITHIN 0.5 MILES FROM "END ROAD WORK" SIGN.
	5	END ROAD WORK	PLACE 500' FOLLOWING THE END OF CONSTRUCTION LIMITS.

NO REQUIRED STATIONARY SIGNING FOR THE FOLLOWING -Y- LINE CONDITIONS:
 1) LESS THAN 1000' OF RESURFACING ALONG -Y- LINE
 2) SUBDIVISION ROADS
 3) DEAD END ROADS

WHEN PAVING/CONSTRUCTION ACTIVITIES PROCEED ACROSS AN UNSIGNED -Y- LINE, ADVANCE WARNING PORTABLE SIGNS SHALL BE USED ALONG THE -Y- LINE AS SHOWN BELOW. REMOVE UPON COMPLETION OF WORK.



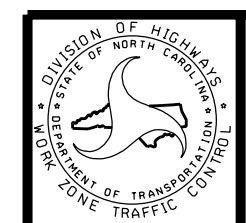

PLACED 500' IN ADVANCE OF FLAGGER. PLACED 250' IN ADVANCE OF FLAGGER.

NOTES:
 1) MAY USE LAW ENFORCEMENT TO CONTROL TRAFFIC AT SIGNALIZED INTERSECTIONS AS DIRECTED BY THE ENGINEER. PROVIDE PORTABLE "ROAD WORK AHEAD" (W20-1) SIGNS 500' IN ADVANCE ALONG BOTH APPROACHES FROM THE SIDE STREETS WHEN PAVING PROCEEDS THROUGH THE INTERSECTION.



RESURFACING
 ADVANCE WARNING SIGNS
 FOR RURAL AND SUBURBAN
 MULTI-LANE ROADWAYS
 W/ SHOULDER SECTIONS



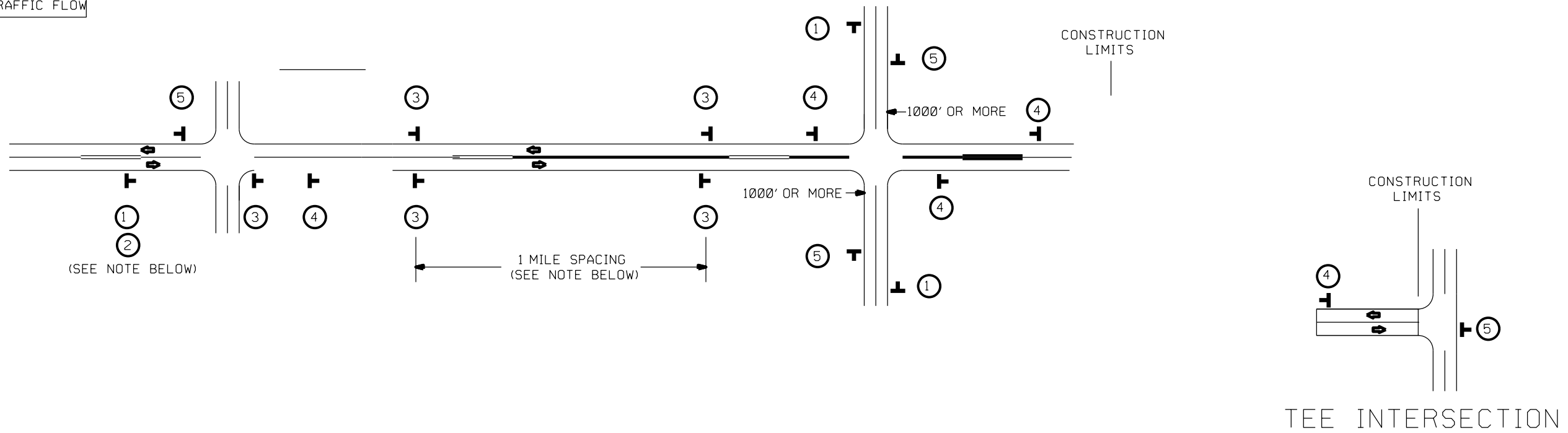

SIGNING FOR RESURFACING PROJECTS

LEGEND
 STATIONARY SIGN
 DIRECTION OF TRAFFIC FLOW

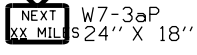

MAINLINE (-L-) SIGNING

-Y- LINE SIGNING

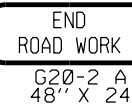

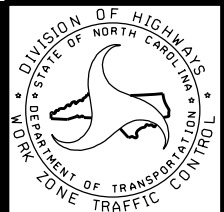
SIGNING NOTES AND PLACEMENT PER DIRECTION	 	PLACE 1000' PRIOR TO BEGINNING OF CONSTRUCTION LIMITS. ONLY USED ON -Y- LINES IF RESURFACING LIMITS EXTEND 1000' ALONG -Y- LINE.	NO REQUIRED STATIONARY SIGNING FOR THE FOLLOWING -Y- LINE CONDITIONS: 1) LESS THAN 1000' OF RESURFACING ALONG -Y- LINE 2) SUBDIVISION ROADS 3) DEAD END ROADS  
			
		- THESE ARE FOR -Y- LINES THAT ARE "THROUGH" ROADWAYS. - DEAD END AND SUBDIVISION ROADS ARE NOT "THROUGH" ROADWAYS. - INSTALL 500' +/- FROM EACH -Y- LINE APPROACH AS SHOWN ABOVE. - FOR MULTIPLE -Y- LINES THAT ARE SEPARATED BY 0.25 MILES OR LESS, TREAT AS A SINGLE UNIT AND INSTALL WITHIN 500' OF EACH APPROACH. - A MAXIMUM OF 2 SIGN SETS PER MILE. DO NOT INSTALL WHEN -Y- LINES ARE WITHIN 0.5 MILES FROM "END ROAD WORK" SIGN. - FOR TEE INTERSECTIONS, INSTALL WITHIN 500' +/- OF THE INTERSECTION ALONG -L- LINE.	
		PLACE 500' FOLLOWING THE END OF CONSTRUCTION LIMITS OR AS SHOWN WHEN WORK ENDS AT A 3-WAY TEE INTERSECTION.	
MAPS LESS THAN 2 MILES	FOR RESURFACING MAPS WITH CONSTRUCTION LIMITS LESS THAN 2 MILES IN LENGTH, NO STATIONARY SIGNS ARE REQUIRED. USE PORTABLE "ROAD UNDER CONSTRUCTION" OR "ROAD WORK AHEAD" SIGNS IN LIEU OF STATIONARY ADVANCE WARNINGS SIGNS.		



ADVANCE WARNING SIGNS FOR RURAL AND SUBURBAN 2-LANE ROADWAY RESURFACING

SIGNING FOR ASPHALT SURFACE TREATMENT

LEGEND



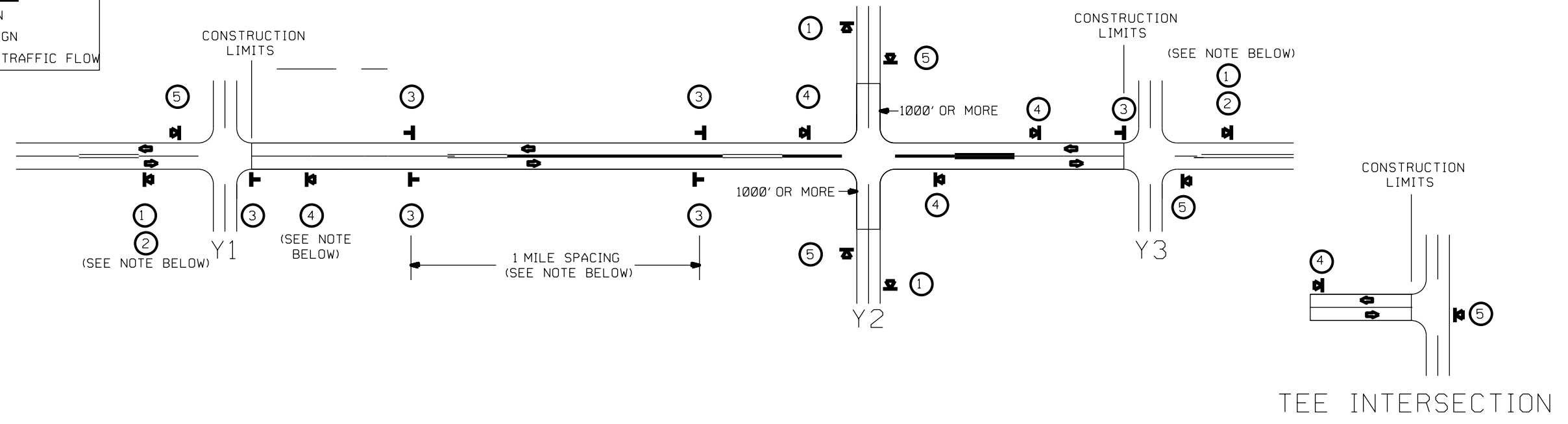



-  PORTABLE SIGN
-  STATIONARY SIGN
-  DIRECTION OF TRAFFIC FLOW



MAINLINE (-L-) SIGNING

-Y- LINE SIGNING

TEE INTERSECTION

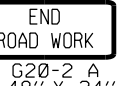
SIGNING NOTES AND PLACEMENT PER DIRECTION	<p>①  W20-1 48" X 48"</p> <p>②  W7-3 P 24" X 18"</p>	<p>- PLACE 1000' PRIOR TO BEGINNING OF CONSTRUCTION LIMITS. ONLY USED ON -Y- LINES IF RESURFACING LIMITS EXTEND 1000' ALONG -Y- LINE.</p> <p>SIGN #2 ONLY USED WHEN RESURFACING LIMITS ARE 2 OR MORE MILES IN LENGTH. ROUND UP TO THE NEAREST WHOLE NUMBER. DO NOT USE FRACTIONAL OR DECIMAL NUMBERS.</p>	<p>STATIONARY SIGNING NOT REQUIRED FOR THE FOLLOWING -Y- LINE CONDITIONS:</p> <p>1) LESS THAN 1000' OF RESURFACING ALONG -Y- LINE 2) SUBDIVISION ROADS 3) DEAD END ROADS</p>
	<p>③  W8-7 48" X 48"</p> <p> SP 48" X 48"</p>	<p>- ALTERNATE THE FOLLOWING TWO SIGNS:</p> <p>- STARTING WITH "LOOSE GRAVEL" (W8-7) FOLLOWED BY "UNMARKED PAVEMENT".</p> <p>- PLACE INITIALLY AT THE CONSTRUCTION LIMITS AND SPACED 1 MILE APART THEREAFTER.</p> <p>- AT TEE INTERSECTIONS INSTALL INITIALLY 0.5 MILE FROM INTERSECTION AND SPACE 1 MILE APART THEREAFTER.</p>	<p>WHEN PAVING/CONSTRUCTION ACTIVITIES PROCEED ACROSS AN UNSIGNED -Y- LINE, PORTABLE ADVANCE WARNING SIGNS SHALL BE USED ALONG THE -Y- LINE AS SHOWN BELOW. REMOVE UPON COMPLETION OF WORK.</p>
	<p>④  SP 13106 48" X 48"</p>	<p>- THESE ARE FOR -Y- LINES THAT ARE "THROUGH" ROADWAYS. DEAD END AND SUBDIVISION ROADS ARE NOT "THROUGH" ROADWAYS.</p> <p>- INSTALL 500' +/- FROM EACH -Y- LINE APPROACH AS SHOWN ABOVE.</p> <p>- FOR MULTIPLE -Y- LINES THAT ARE SEPARATED BY 0.25 MILES OR LESS, TREAT AS A SINGLE UNIT AND INSTALL WITHIN 500' OF EACH APPROACH.</p> <p>- A MAXIMUM OF 2 SIGN SETS PER MILE. DO NOT INSTALL WHEN -Y- LINES ARE WITHIN 0.5 MILES FROM "END ROAD WORK" SIGN.</p>	<p> W20-1 48" X 48"</p> <p>PLACED 500' IN ADVANCE OF FLAGGER.</p> <p> W20-7 A 48" X 48"</p> <p>PLACED 250' IN ADVANCE OF FLAGGER.</p>
	<p>⑤  G20-2 A 48" X 24"</p>	<p>PLACE 500' FOLLOWING THE END OF CONSTRUCTION LIMITS OR AS SHOWN WHEN WORK ENDS AT A 3-WAY TEE INTERSECTION.</p>	
	<p>THE ABOVE SIGNS ARE ALL THAT ARE REQUIRED FOR A CONTRACTOR TO BEGIN A RESURFACING CONTRACT. ANY ADDITIONAL SIGNS REQUESTED BY NCDOT DIVISIONS SHALL BE INSTALLED WITHIN 7 BUSINESS DAYS OF THE START OF CONTRACT WORK.</p>		

MAPS LESS THAN 2 MILES

FOR AST RESURFACING MAPS WITH CONSTRUCTION LIMITS LESS THAN 2 MILES IN LENGTH, USE A STATIONARY "LOOSE GRAVEL" SIGN AT THE BEGINNING CONSTRUCTION LIMIT FOLLOWED BY AN "UNMARKED PAVEMENT" SIGN MIDWAY THROUGH AND AN "END ROAD WORK" SIGN AT THE END CONSTRUCTION LIMIT.

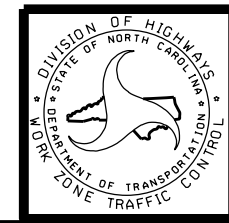

ADVANCE WARNING SIGNS FOR 2-LANE ROADWAY ASPHALT SURFACE TREATMENT

High Speed Detection (≥40 mph)

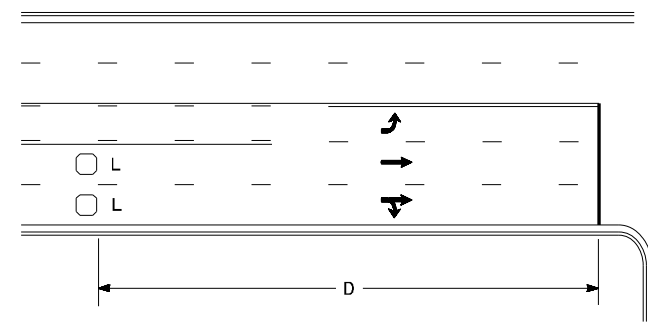

Speed Limit mph	D ft
40	250
45	300
50	355
55	420

L = 6ft X 6ft
 Wired in series for TS1
 Controllers
 Wired separately for TS2,
 170, and 2070L Controllers

Volume Density Operation

OR

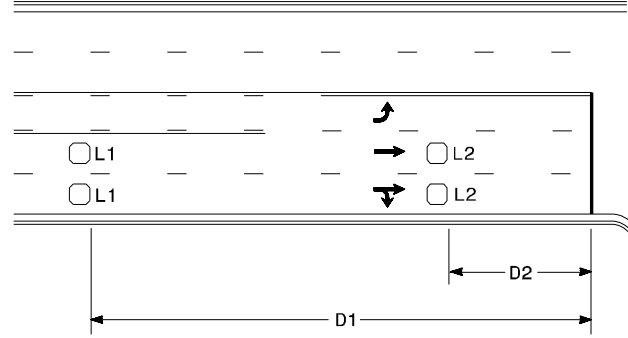

Speed Limit mph	D1 ft	D2 ft
40	250	80
45	300	90
50	355	100
55	420	110

L1 = 6ft X 6ft
 Wired in series

L2 = 6ft X 6ft
 Wired in series

"Stretch" Operation

Low Speed Detection (≤35 mph)

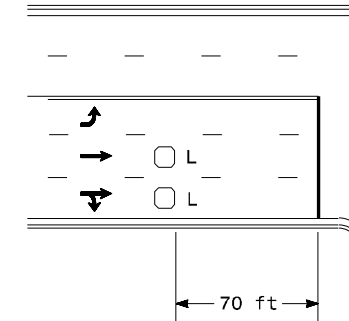

L = 6ft X 6ft
 Wired in series

OR

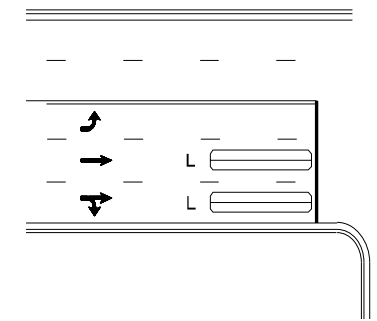

L = 6ft X 40ft
 Quadrupole loop, wired separately

Left Turn Lane Detection

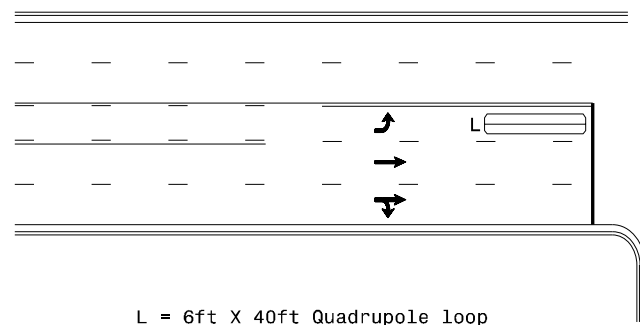

L = 6ft X 40ft Quadrupole loop

Presence Loop Detection

OR

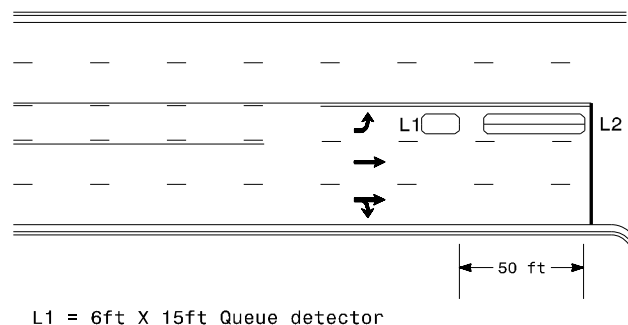

L1 = 6ft X 15ft Queue detector
 L2 = 6ft X 40ft Quadrupole loop

Queue Loop Detection

Right Turn Lane Detection

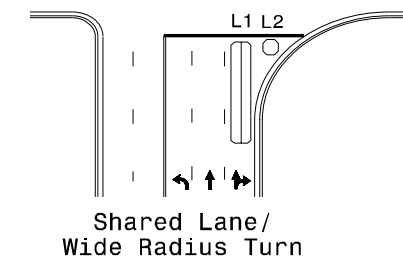

Shared Lane/
 Wide Radius Turn

L1 = 6ft X 40ft Quadrupole loop
 L2 = 6ft X 6ft [Minimum] Presence loop
 Wired separately

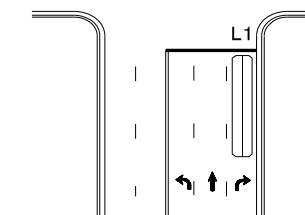

Standard Turn

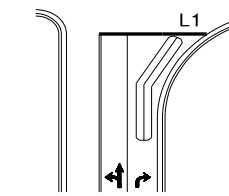

Wide Radius Turn

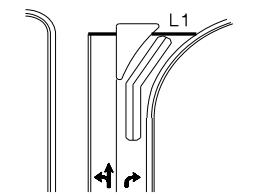

Channelized Turn

Side Street Detection

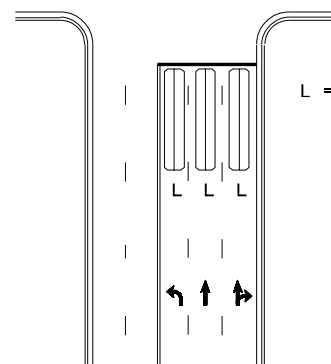

L = 6ft X 40ft
 Quadrupole loop
 Wired to separate
 detectors/channels

Presence Loop Placement at Stop Lines

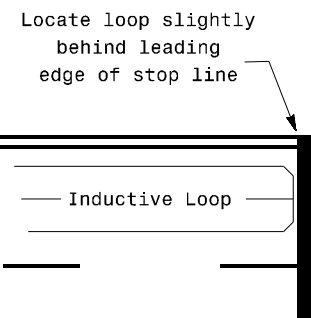

Note:
 Loop may be located in advance
 of stop line under any of the
 following conditions:
 1) stop line is greater than 15'
 from edge of intersecting
 roadway
 2) loop detects a permissive or
 protected/permissive left turn
 3) for an exclusive right turn
 lane

Recommended Number of Turns

Single 6' X 6' loop
 (when wired separately):

Length of Lead-in ft	Number of Turns
< 250	3
250-375	4
375-525	5
> 525	6

Quadrupole loops: Use 2-4-2 turns

6' X 15' Loops:
 Lead-in < 150', use 2 turns
 Lead-in > 150', use 3 turns

Typical Signal Loop Locations

PLAN DATE: January 2015	REVIEWED BY: JPG
PREPARED BY: PLA	REVIEWED BY:
REVISIONS	INIT. DATE

SCALE: N/A

1/30/2015

