



STATE OF NORTH CAROLINA
DEPARTMENT OF TRANSPORTATION

PATRICK L. MCCRORY
GOVERNOR

P.O. Box 25201, RALEIGH, NC 27611-5201
PHONE (919) 733-2520

ANTHONY J. TATA
SECRETARY

January 10, 2013

Addendum No. 1

SUBJECT: Contract No. 11-02-513
WBS Element No. To Be Assigned
Long-Arm Mowing on Various Routes upon request in Caldwell County, North Carolina

January 17, 2013 Bid Opening

To Whom It May Concern:

Reference is made to the Contract Proposal recently furnished to you on the above-mentioned project. The following revisions have been made to the Contract Proposal:

Page 22, ESTIMATED SUMMARY OF QUANTITIES, has been revised. This revision removed the quantity for Long Arm Mowing on Secondary Unpaved Routes. Please void **Page 22** in your proposal and staple the **Revised Page 22** thereto.

Pages 23-24, MOWING LIMITS, have been revised. This revision modified the detail distances for the mowing limits in this contract. Please void **Pages 23-24** in your proposal and staple the **Revised Pages 23-24** thereto.

Page 30, CONTRACT BID FORM, has been revised. This revision removed Pay Item for Long Arm Mowing on Secondary Unpaved Routes. Please void **Page 30** in your proposal and staple the **Revised Page 30** thereto.

If you have any questions regarding this matter, please feel free to contact me at 336-903-9138.

Sincerely,

A handwritten signature in cursive script that reads "Joe L. Laws".

Joe L. Laws, PE
Division Project Manager

Acknowledgement of Receipt

Company Name

Signature

Date

both directions and one top of the cab mounted amber rotating light, visible from both directions. The Contractor must furnish, mount, and maintain a “Caution Mower” sign on the rear of each mower. In addition, the Contractor shall display his company name on each tractor.

The Contractor shall furnish all equipment in good operating condition and operated by properly trained and qualified personnel. There will be **no payment for mobilization** of labor and equipment, as it will be **considered incidental** to the bid items of this contract. The Contractor shall be responsible for all costs or charges incurred in the operation and maintenance of the equipment during the performance of this contract.

ESTIMATED SUMMARY OF QUANTITIES

LONG ARM MOWING ALONG VARIOUS ROUTES IN AVERY COUNTY

- (Primary Routes).....100 SHOULDER MILES

- (Secondary Paved Routes).....100 SHOULDER MILES

- (Divided Highway).....100 SHOULDER MILES

The Contractor shall be required to cut and mulch any tree five (5) inches or less in diameter as close to the ground as the mowing will allow.

***NOTE* ---- LONG-ARM MOWING WILL BE DETERMINED BY NEED – PRIORITIES WILL BE SET AFTER NEEDS HAVE BEEN DETERMINED – QUANTITIES ARE ESTIMATES AND ARE FOR INFORMATION ONLY.**

MOWING LIMITS

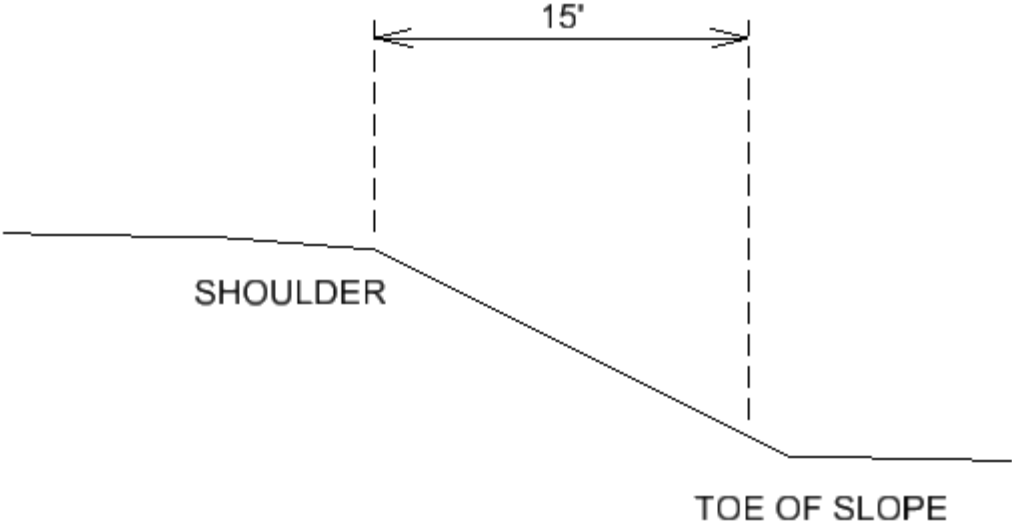

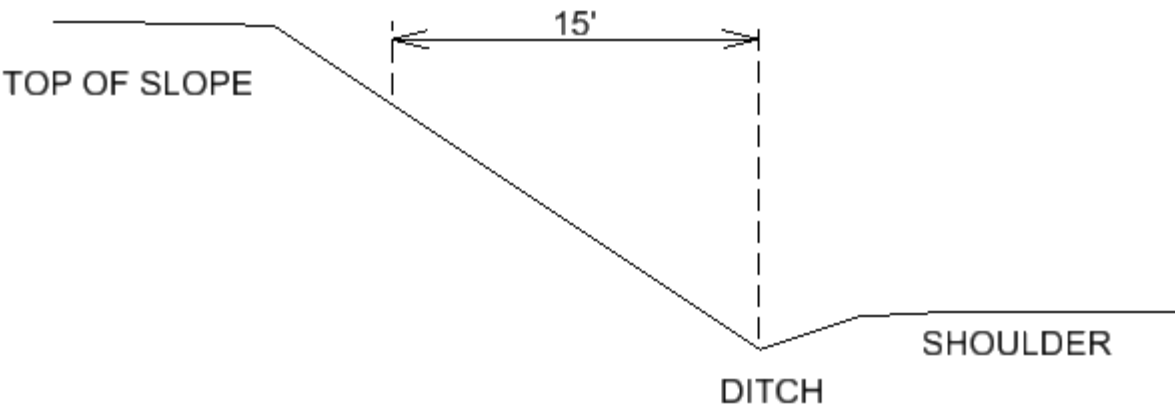

NORTH CAROLINA DEPARTMENT OF TRANSPORTATION BID FORM

WBS Element: To Be Assigned

Contract Number: 11-02-513

DESCRIPTION: Long-Arm Mowing on Various Routes upon request in Caldwell County, North Carolina

PAGE 1 OF 1

ITEM	SECT	DESCRIPTION	QUANTITY	UNIT	UNIT PRICE	AMOUNT BID
1	SP	Long-Arm Mowing – Primary Routes	100	SMI		
2	SP	Long-Arm Mowing- Secondary Paved Routes	100	SMI		
3	SP	Long-Arm Mowing- Divided Highway	100	SMI		

***ESTIMATED QUANTITIES ONLY - These quantities are for bid purposes only. Actual quantities may vary greatly from the estimated quantities.**

TOTAL BID FOR PROJECT: _____

THIS SECTION TO BE COMPLETED BY NORTH CAROLINA DEPARTMENT OF TRANSPORTATION

This bid has been reviewed in accordance with Article 103-1 of the Standard Specifications for Roads and Structures 2012.

Reviewed by _____ (date)