

**TIP PROJECT: 17BP.2.R.53**

**CONTRACT: DB00160**

See Sheet 1-A For Index of Sheets

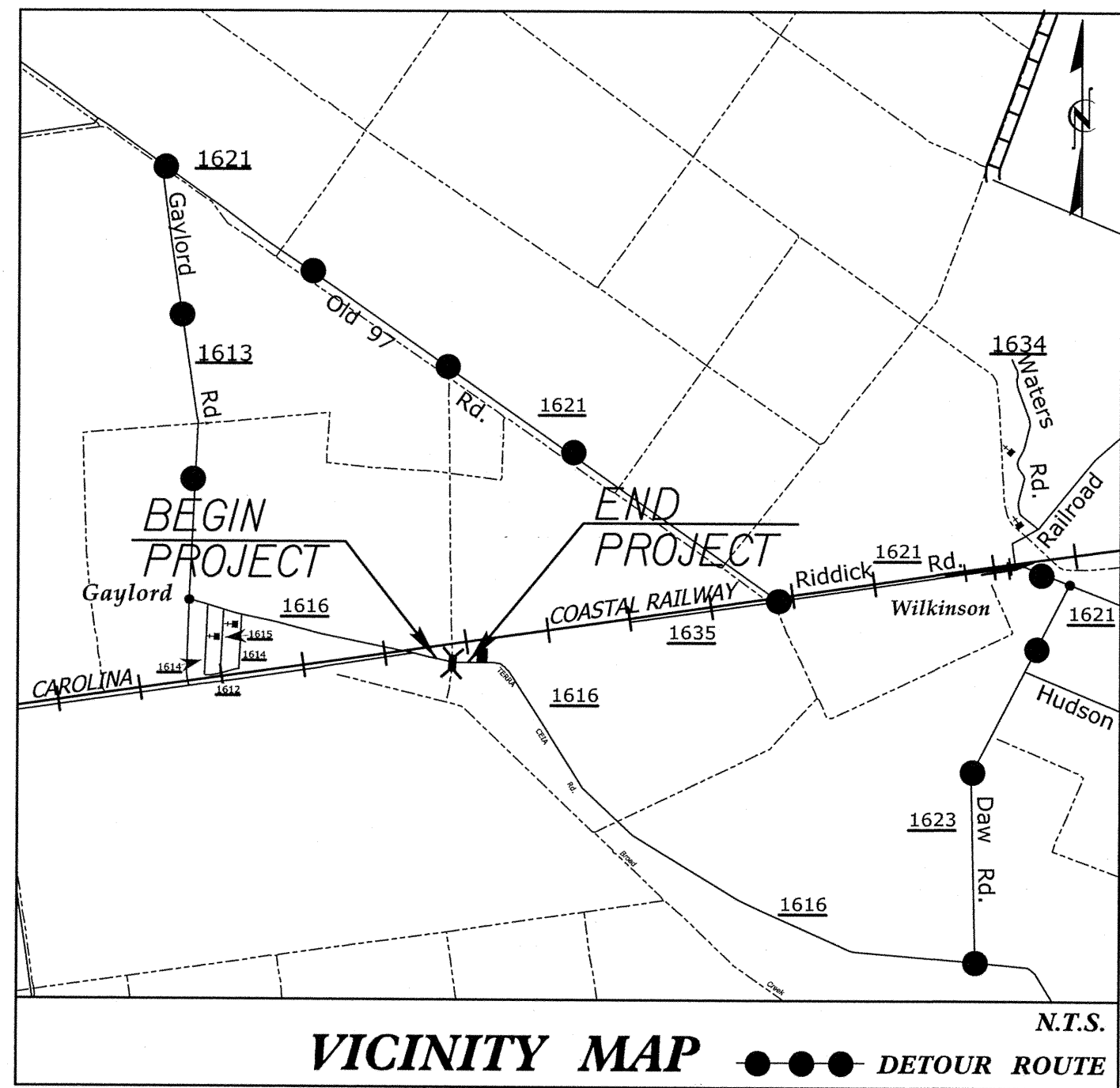

STATE OF NORTH CAROLINA  
DIVISION OF HIGHWAYS

**BEAUFORT COUNTY**

**LOCATION: BRIDGE NO.161 OVER BROAD CREEK CANAL  
ON SR 1616 (TERRA CEIA RD.)**

**TYPE OF WORK: GRADING, PAVING, DRAINAGE & CULVERT**

STATE	PROJECT REFERENCE NO.	SHEET NO.	TOTAL SHEETS
NC	17BP.2.R.53	1	X
STATE PROJ. NO.		DESCRIPTION	
17BP.2.R.53		CONST	

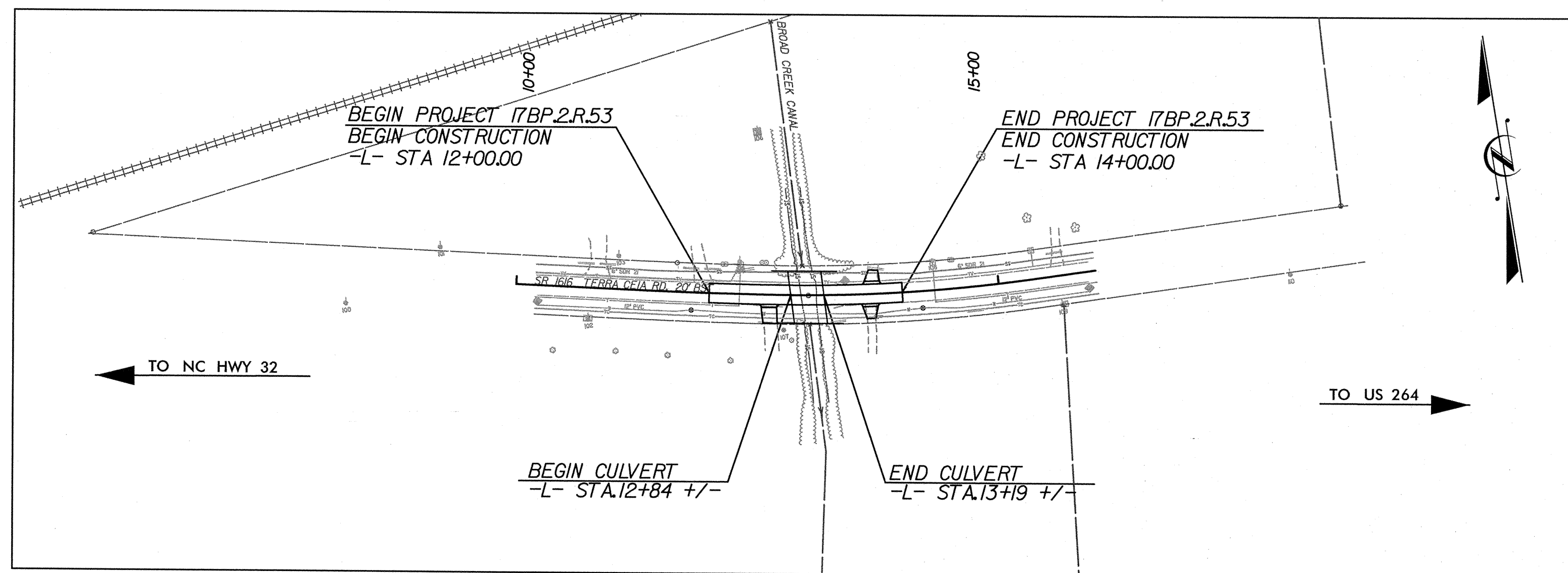

CLEARING ON THIS PROJECT SHALL BE PERFORMED TO THE LIMITS ESTABLISHED BY METHOD II.

<p><b>GRAPHIC SCALES</b></p> <p>50 25 0 50 100 PLANS</p> <p>50 25 0 50 100 PROFILE (HORIZONTAL)</p> <p>10 5 0 10 20 PROFILE (VERTICAL)</p>	<p><b>DESIGN DATA</b></p> <p>ADT 2010 = 190 ADT 2035 = 380 DHV = 10% D = 60% T = 6% * ADVISORY = 40 MPH STATUTORY = 55 MPH * TTST 2% DUAL 4% SUBREGIONAL TIER</p>	<p><b>PROJECT LENGTH</b></p> <p>LENGTH OF ROADWAY TIP PROJECT 17BP.2.R.53 = 0.03 MI. LENGTH OF STRUCTURE TIP PROJECT 17BP.2.R.53 = 0.01 MI. TOTAL LENGTH OF TIP PROJECT 17BP.2.R.53 = 0.04 MI.</p>	<p>Prepared In the Office of:</p> <p><b>HNTB</b> HNTB NORTH CAROLINA, P.C. 343 E. Six Forks Road, Suite 200 Raleigh, North Carolina 27609 NC License No: C-1554</p> <p>2012 STANDARD SPECIFICATIONS</p> <p><b>RIGHT OF WAY DATE:</b> SEPTEMBER 20, 2013</p> <p><b>LETTING DATE:</b> JANUARY 22, 2014</p> <p><b>ENRICO A. ROQUE, P.E.</b> PROJECT ENGINEER</p> <p><b>ANTHONY THOMPSON, P.E.</b> PROJECT DESIGNER</p> <p><b>MARIA ROGERSON, P.E.</b> NCDOT CONTACT</p>	<p><b>HYDRAULICS ENGINEER</b></p> <p><i>James C. Byrd</i> SIGNATURE: 12/11/13</p> <p><b>ROADWAY DESIGN ENGINEER</b></p> <p><i>Enrico A. Roque</i> SIGNATURE: 12/11/13</p>	<p><b>DIVISION OF HIGHWAYS STATE OF NORTH CAROLINA</b></p> <p>STATE HIGHWAY DESIGN ENGINEER</p>
--	---	--	--	---	---

12/11/2013 12:41:28 PM ... \PProj\060160\1\_rdy\_tsh.dgn

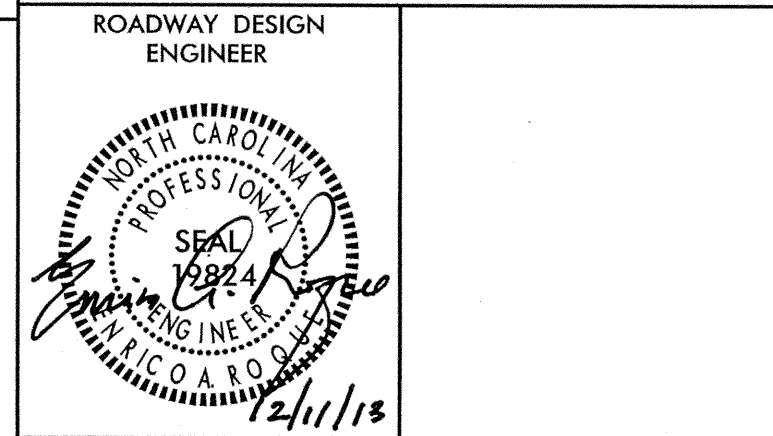

**INDEX OF SHEETS**

SHEET NUMBER	SHEET
1	TITLE SHEET
1-A	INDEX OF SHEETS, GENERAL NOTES & LIST OF STANDARDS
1-B	SYMBOLGY SHEET
2	TYPICAL SECTION SHEET
3	EARTHWORK, PAVEMENT REMOVAL, & ROW SUMMARY
4	PLAN & PROFILE SHEET
TMP-1 THRU TMP-2	TRAFFIC CONTROL PLANS
EC-1 THRU EC-7	EROSION CONTROL PLANS
P-1	PERMIT DRAWING
X-1 THRU X-3	-L- CROSS SECTION SHEETS
U0-1 THRU U0-2	UTILITIES BY OTHERS

**GENERAL NOTES:**

2012 SPECIFICATIONS  
 EFFECTIVE: 01-17-2012  
 REVISED: 07-30-2012

EFF. 01-17-2012  
 REV. 10-30-2012

**GRADE LINE:  
 GRADING AND SURFACING:**

THE GRADE LINES SHOWN DENOTE THE FINISHED ELEVATION OF THE PROPOSED SURFACING AT GRADE POINTS SHOWN ON THE TYPICAL SECTIONS. GRADE LINES MAY BE ADJUSTED AT THEIR BEGINNING AND ENDING AND AT STRUCTURES AS DIRECTED BY THE ENGINEER IN ORDER TO SECURE A PROPER TIE-IN.

**CLEARING:**

CLEARING ON THIS PROJECT SHALL BE PERFORMED TO THE LIMITS ESTABLISHED BY METHOD II.

**SUPERELEVATION:**

ALL CURVES ON THIS PROJECT SHALL BE SUPERELEVATED IN ACCORDANCE WITH STD. NO. 225.04 SUPERELEVATION IS TO BE REVOLVED ABOUT THE GRADE POINTS SHOWN ON THE TYPICAL SECTIONS.

**SHOULDER CONSTRUCTION:**

ASPHALT, EARTH, AND CONCRETE SHOULDER CONSTRUCTION ON THE HIGH SIDE OF SUPERELEVATED CURVES SHALL BE IN ACCORDANCE WITH STD. 560.01.

**SIDE ROADS:**

THE CONTRACTOR WILL BE REQUIRED TO DO ALL NECESSARY WORK TO PROVIDE SUITABLE CONNECTIONS WITH ALL ROADS, STREETS, AND DRIVES ENTERING THIS PROJECT. THIS WORK WILL BE PAID FOR AT THE CONTRACT UNIT PRICE FOR THE PARTICULAR ITEMS INVOLVED.

**DRIVEWAYS:**

DRIVEWAYS SHALL BE CONSTRUCTED IN ACCORDANCE WITH STD. 848.02 USING 3' RADII OR RADII AS SHOWN ON THE PLANS. LOCATIONS OF DRIVES WILL BE AS SHOWN ON THE PLANS OR AS DIRECTED BY THE ENGINEER.

**TEMPORARY SHORING:**

SHORING REQUIRED FOR THE MAINTENANCE OF TRAFFIC WILL BE PAID FOR AS "EXTRA WORK" IN ACCORDANCE WITH SECTION 104-7.

**SUBSURFACE PLANS:**

NO SUBSURFACE PLANS ARE AVAILABLE ON THIS PROJECT. THE CONTRACTOR SHOULD MAKE HIS OWN INVESTIGATION AS TO THE SUBSURFACE CONDITIONS.

**UTILITIES:**

UTILITY OWNERS ON THIS PROJECT ARE

Power - City of Washington; Phone - Tri-County Telephone;

Phone - Centurylink; Water - Beaufort County Water

Sewer - Town of Belhaven

ANY RELOCATION OF EXISTING UTILITIES WILL BE ACCOMPLISHED BY OTHERS.

**RIGHT-OF-WAY MARKERS:**

ALL RIGHT-OF-WAY MARKERS ON THIS PROJECT SHALL BE PLACED BY OTHERS.

**2012 ROADWAY ENGLISH STANDARD DRAWINGS**

The following Roadway Standards as appear in "Roadway Standard Drawings" Highway Design Branch - N. C. Department of Transportation - Raleigh, N. C., Dated January, 2012 are applicable to this project and by reference hereby are considered a part of these plans:

STD.NO.	TITLE
DIVISION 2 - EARTHWORK	
200.02	Method of Clearing - Method II
225.02	Guide for Grading Subgrade - Secondary and Local
225.04	Method of Obtaining Superelevation - Two Lane Pavement
DIVISION 3 - PIPE CULVERTS	
300.01	Method of Pipe Installation
310.10	Driveway Pipe Construction
DIVISION 5 - SUBGRADE, BASES AND SHOULDERS	
560.01	Method of Shoulder Construction - High Side of Superelevated Curve - Method I
DIVISION 8 - INCIDENTALS	
848.02	Driveway Turnout - Radius Type
876.01	Rip Rap in Channels

REVISIONS













**Note: Not to Scale**

\*S.U.E. = *Subsurface Utility Engineering*











STATE OF NORTH CAROLINA  
DIVISION OF HIGHWAYS

# CONVENTIONAL PLAN SHEET SYMBOLS









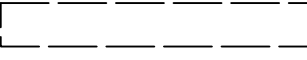

**BOUNDARIES AND PROPERTY:**

State Line	_____
County Line	_____
Township Line	_____
City Line	_____
Reservation Line	_____
Property Line	_____
Existing Iron Pin	_____ 
Property Corner	_____ 
Property Monument	_____ 
Parcel/Sequence Number	_____ 
Existing Fence Line	_____ 
Proposed Woven Wire Fence	_____ 
Proposed Chain Link Fence	_____ 
Proposed Barbed Wire Fence	_____ 
Existing Wetland Boundary	_____ 
Proposed Wetland Boundary	_____ 
Existing Endangered Animal Boundary	_____ 
Existing Endangered Plant Boundary	_____ 





**BUILDINGS AND OTHER CULTURE:**

Gas Pump Vent or U/G Tank Cap	_____ 
Sign	_____ 
Well	_____ 
Small Mine	_____ 
Foundation	_____ 
Area Outline	_____ 
Cemetery	_____ 
Building	_____ 
School	_____ 
Church	_____ 
Dam	_____ 











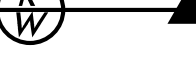

**HYDROLOGY:**

Stream or Body of Water	_____
Hydro, Pool or Reservoir	_____ 
Jurisdictional Stream	_____ 
Buffer Zone 1	_____ 
Buffer Zone 2	_____ 
Flow Arrow	_____ 
Disappearing Stream	_____ 
Spring	_____ 
Wetland	_____ 
Proposed Lateral, Tail, Head Ditch	_____ 
False Sump	_____ 









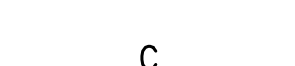

**RAILROADS:**

Standard Gauge	_____ 
RR Signal Milepost	_____ 
Switch	_____ 
RR Abandoned	_____ 
RR Dismantled	_____ 

**RIGHT OF WAY:**

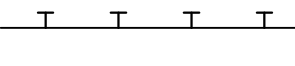
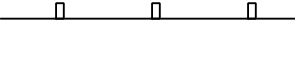
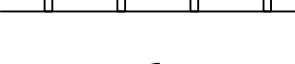
Baseline Control Point	_____ 
Existing Right of Way Marker	_____ 
Existing Right of Way Line	_____ 
Proposed Right of Way Line	_____ 
Proposed Right of Way Line with Iron Pin and Cap Marker	_____ 
Proposed Right of Way Line with Concrete or Granite Marker	_____ 
Existing Control of Access	_____ 
Proposed Control of Access	_____ 
Existing Easement Line	_____ 
Proposed Temporary Construction Easement	_____ 
Proposed Temporary Drainage Easement	_____ 
Proposed Permanent Drainage Easement	_____ 
Proposed Permanent Utility Easement	_____ 







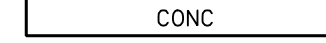

**ROADS AND RELATED FEATURES:**

Existing Edge of Pavement	_____ 
Existing Curb	_____ 
Proposed Slope Stakes Cut	_____ 
Proposed Slope Stakes Fill	_____ 
Proposed Wheel Chair Ramp	_____ 
Proposed Wheel Chair Ramp Curb Cut	_____ 
Curb Cut for Future Wheel Chair Ramp	_____ 
Existing Metal Guardrail	_____ 
Proposed Guardrail	_____ 
Existing Cable Guiderail	_____ 
Proposed Cable Guiderail	_____ 
Equality Symbol	_____ 
Pavement Removal	_____ 

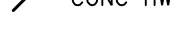



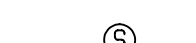
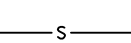



**VEGETATION:**

Single Tree	_____ 
Single Shrub	_____ 
Hedge	_____ 
Woods Line	_____ 
Orchard	_____ 
Vineyard	_____ 

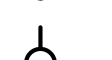
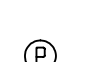



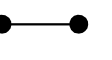
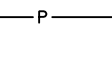
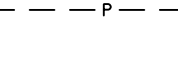



**EXISTING STRUCTURES:**

MAJOR:	
Bridge, Tunnel or Box Culvert	_____ 
Bridge Wing Wall, Head Wall and End Wall	_____ 
MINOR:	
Head and End Wall	_____ 
Pipe Culvert	_____ 
Footbridge	_____ 
Drainage Box: Catch Basin, DI or JB	_____ 
Paved Ditch Gutter	_____ 
Storm Sewer Manhole	_____ 
Storm Sewer	_____ 

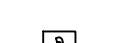
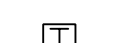

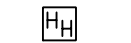
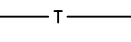
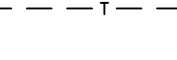
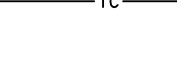

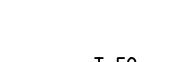

**UTILITIES:**

POWER:	
Existing Power Pole	_____ 
Proposed Power Pole	_____ 
Existing Joint Use Pole	_____ 
Proposed Joint Use Pole	_____ 
Power Manhole	_____ 
Power Line Tower	_____ 
Power Transformer	_____ 
U/G Power Cable Hand Hole	_____ 
H-Frame Pole	_____ 
Recorded U/G Power Line	_____ 
Designated U/G Power Line (S.U.E.*)	_____ 









**TELEPHONE:**

Existing Telephone Pole	_____ 
Proposed Telephone Pole	_____ 
Telephone Manhole	_____ 
Telephone Booth	_____ 
Telephone Pedestal	_____ 
Telephone Cell Tower	_____ 
U/G Telephone Cable Hand Hole	_____ 
Recorded U/G Telephone Cable	_____ 
Designated U/G Telephone Cable (S.U.E.*)	_____ 
Recorded U/G Telephone Conduit	_____ 
Designated U/G Telephone Conduit (S.U.E.*)	_____ 
Recorded U/G Fiber Optics Cable	_____ 
Designated U/G Fiber Optics Cable (S.U.E.*)	_____ 





**WATER:**

Water Manhole	_____ 
Water Meter	_____ 
Water Valve	_____ 
Water Hydrant	_____ 
Recorded U/G Water Line	_____ 
Designated U/G Water Line (S.U.E.*)	_____ 
Above Ground Water Line	_____ 







**TV:**

TV Satellite Dish	_____ 
TV Pedestal	_____ 
TV Tower	_____ 
U/G TV Cable Hand Hole	_____ 
Recorded U/G TV Cable	_____ 
Designated U/G TV Cable (S.U.E.*)	_____ 
Recorded U/G Fiber Optic Cable	_____ 
Designated U/G Fiber Optic Cable (S.U.E.*)	_____ 











**GAS:**

Gas Valve	_____ 
Gas Meter	_____ 
Recorded U/G Gas Line	_____ 
Designated U/G Gas Line (S.U.E.*)	_____ 
Above Ground Gas Line	_____ 

**SANITARY SEWER:**

Sanitary Sewer Manhole	_____ 
Sanitary Sewer Cleanout	_____ 
U/G Sanitary Sewer Line	_____ 
Above Ground Sanitary Sewer	_____ 
Recorded SS Forced Main Line	_____ 
Designated SS Forced Main Line (S.U.E.*)	_____ 

**MISCELLANEOUS:**

Utility Pole	_____ 
Utility Pole with Base	_____ 
Utility Located Object	_____ 
Utility Traffic Signal Box	_____ 
Utility Unknown U/G Line	_____ 
U/G Tank; Water, Gas, Oil	_____ 
A/G Tank; Water, Gas, Oil	_____ 
U/G Test Hole (S.U.E.*)	_____ 
Abandoned According to Utility Records	_____ 
End of Information	_____ 



PAVEMENT SCHEDULE	
C1	PROP. APPROX. 3.0" ASPHALT CONCRETE SURFACE COURSE, TYPE SF9.5A, AT AN AVERAGE RATE OF 165 LBS. PER SQ. YARD IN EACH OF TWO LAYERS.
D	PROP. APPROX. 2.5" ASPHALT CONCRETE INTERMEDIATE COURSE, TYPE I19.0B, AT AN AVERAGE RATE OF 285 LBS. PER SQ. YD.
D1	PROP. VAR. DEPTH ASPHALT CONCRETE INTERMEDIATE COURSE, TYPE I19.0B, AT AN AVERAGE RATE OF 114 LBS. PER SQ. YD. PER 1" DEPTH, TO BE PLACED IN LAYERS NOT LESS THAN 2 1/2" IN DEPTH OR GREATER THAN 4" IN DEPTH.
E	PROP. APPROX. 4" ASPHALT CONCRETE BASE COURSE, TYPE B25.0B, AT AN AVERAGE RATE OF 456 LBS. PER SQ. YARD.
E1	PROP. VARIABLE DEPTH ASPHALT CONCRETE BASE COURSE, TYPE B25.0B AT AN AVERAGE RATE OF 114 LBS. PER SQ. YARD PER INCH DEPTH, TO BE PLACED IN LAYERS NOT GREATER THAN 5.5" IN DEPTH OR LESS THAN 3" IN DEPTH.
T	EARTH MATERIAL
U	EXISTING PAVEMENT
W	WEDGING (SEE DETAIL)

ALL PAVEMENT EDGE SLOPES ARE 1:1 UNLESS SHOWN OTHERWISE

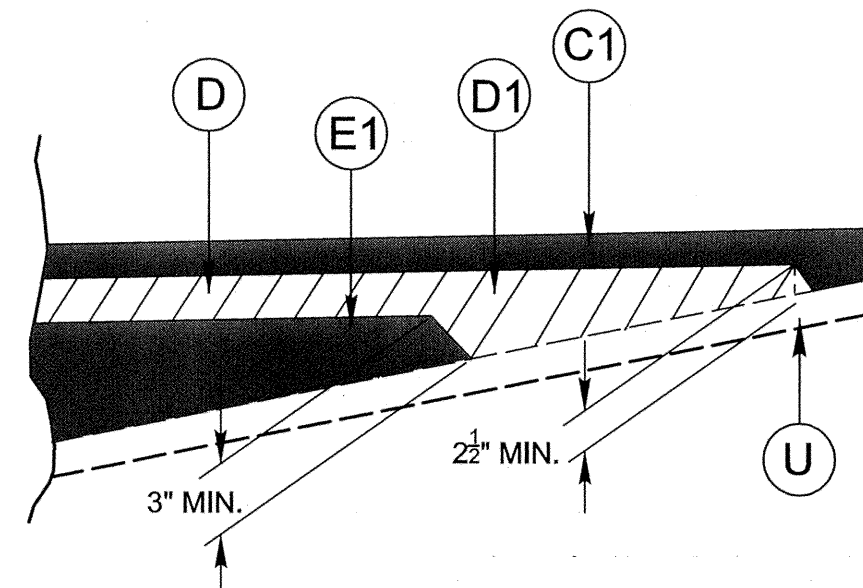

**DETAIL SHOWING METHOD OF WEDGING**  
 SEE TYPICAL SECTIONS

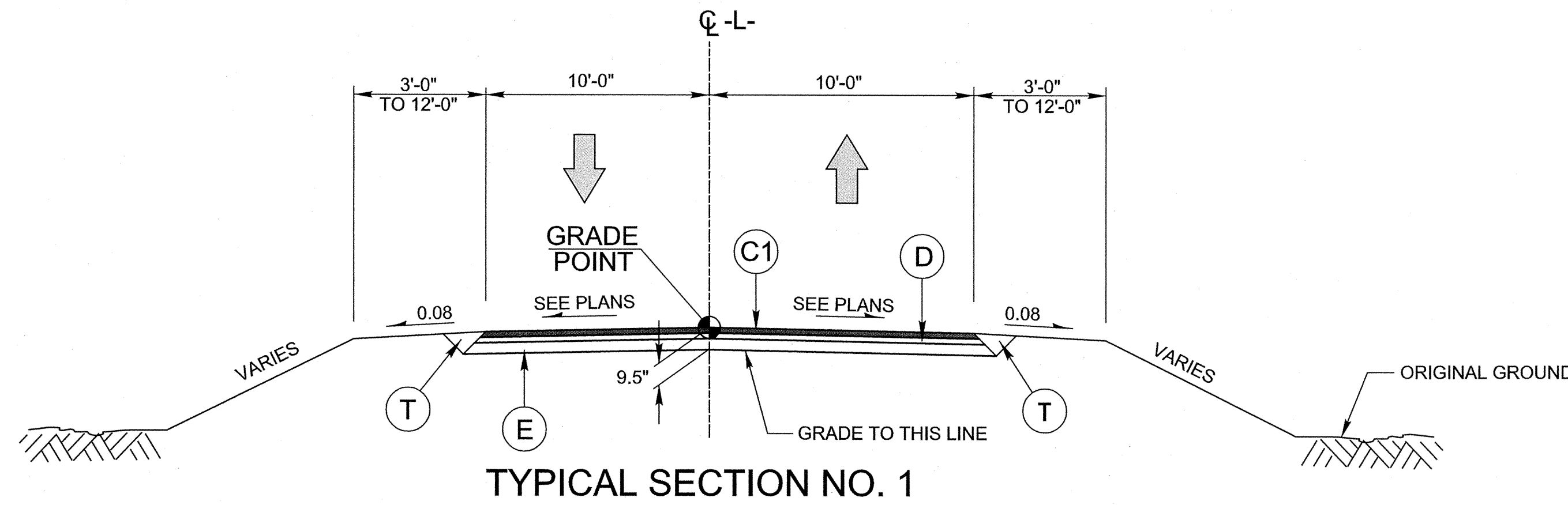

USE TYPICAL SECTION NO. 1 FROM:  
 -L- STA. 12+00.00 TO -L- STA. 14+00.00

REVISIONS



Note: Approximate quantities only. Unclassified Excavation, Borrow Excavation, Fine Grading, Clearing and Grubbing, and Removal of Existing Pavement will be paid for at the contract lump sum price for "Grading."

**HNTB** HNTB NORTH CAROLINA, P.C.  
343 E. Six Forks Road, Suite 200  
Raleigh, North Carolina 27609  
NC License No: C-1554

PROJECT REFERENCE NO.	SHEET NO.
17BP.2.R.53	3
RW SHEET NO.	
ROADWAY DESIGN ENGINEER	

### ROW AREA DATA SUMMARY

PARCEL NO.	PROPERTY OWNERS NAMES	TOTAL ACREAGE	AREA TAKEN (SQFT)	AREA REMAINING RT.	AREA REMAINING LT.	CONST. EASE.	PERM. DRAIN. EASE.	TEMP. DRAIN. EASE.
1	CROP PRODUCTION SERVICES	-				664.3 SF		
2	CONWAY CAROWAN	-				545.4 SF		
3	WALTER J. SAWYER	-				871.1 SF		
4	WALTER J. SAWYER	-					616.1 SF	

### SUMMARY OF EARTHWORK IN CUBIC YARDS

STATION	STATION	UNCLASSIFIED EXCAVATION	EMBANK. +%	BORROW	WASTE
-L- STA. 12+00.00	-L- STA. 12+84.00	46	174	128	
-L- STA. 13+19.00	-L- STA. 14+00.00	42	224	182	
PROJECT SUBTOTAL		88	398	310	0
WASTE TO REPLACE BORROW				0	0
PROJECT TOTAL		88	398	310	0
GRAND TOTALS:		88		310	
SAY:		90		310	

### DRAINAGE SUMMARY

STATION	LOCATION (LT, RT, OR CL)	STRUCTURE NO.		TOP ELEVATION	INVERT ELEVATION	INVERT ELEVATION	SLOPE CRITICAL	DRAINAGE PIPE (RCP, CSP, CAAP, HDPE, or PVC)					QUANTITIES FOR DRAINAGE STRUCTURES			T.B.D.I. FRAME AND TWO GRATES STD. 840.29	REMARKS	
		FROM	TO					15"	18"	24"	DO NOT USE RCP	DO NOT USE CSP	DO NOT USE CAAP	DO NOT USE HDPE	DO NOT USE PVC			PER EACH (0 THRU 5.0')
-L- 12+70.00	RT			6.75	1.00						X	X						
-L- 13+32.00	RT			7.45	1.00						X	X						
TOTAL								36	20									

### PAVEMENT REMOVAL SUMMARY IN SQUARE YARDS

LOCATION	REMOVAL OF ASPHALT PAVEMENT	BREAKING OF ASPHALT PAVEMENT
-L- STA. 12+00 TO 12+76	181	
-L- STA. 13+30 TO 14+00	165	
GRAND TOTAL	346	
SAY	350	

REVISIONS



-L-  
 PI Sta 11+98.69    PI Sta 13+96.68  
 $\Delta = 1^{\circ}24'22.7''$  (LT)     $\Delta = 9^{\circ}17'56.5''$  (LT)  
 $D = 1^{\circ}08'45.3''$      $D = 3^{\circ}24'37.7''$   
 $L = 122.72'$      $L = 272.66'$   
 $T = 61.36'$      $T = 136.63'$   
 $R = 5,000.00'$      $R = 1,680.00'$

PROJECT REFERENCE NO. <b>17BP.2.R.53</b>	SHEET NO. <b>4</b>
ROADWAY DESIGN ENGINEER	HYDRAULICS ENGINEER
12/11/13	12/11/13

**PLAN**

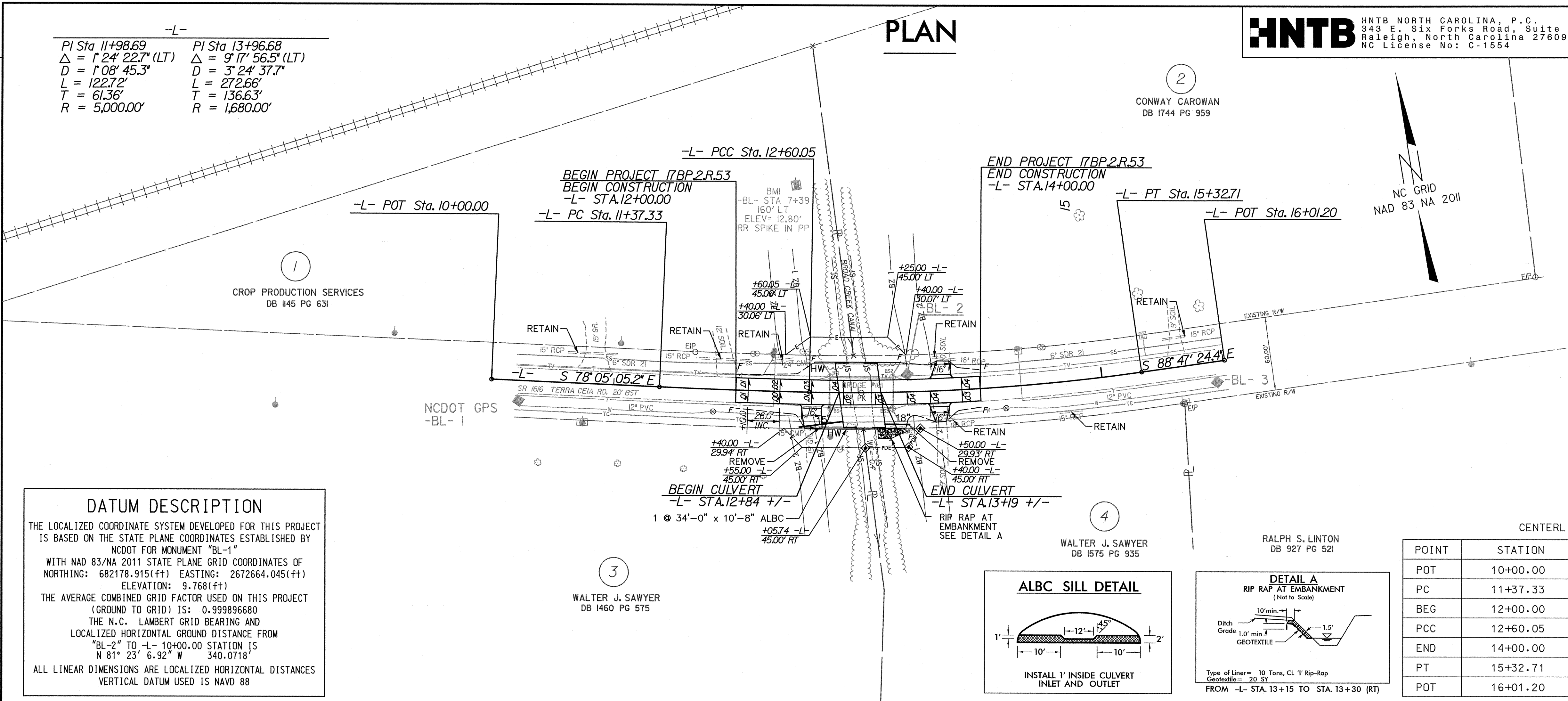

**DATUM DESCRIPTION**  
 THE LOCALIZED COORDINATE SYSTEM DEVELOPED FOR THIS PROJECT IS BASED ON THE STATE PLANE COORDINATES ESTABLISHED BY NCDOT FOR MONUMENT "BL-1" WITH NAD 83/NA 2011 STATE PLANE GRID COORDINATES OF NORTHING: 682178.915(±ft) EASTING: 2672664.045(±ft) ELEVATION: 9.768(±ft) THE AVERAGE COMBINED GRID FACTOR USED ON THIS PROJECT (GROUND TO GRID) IS: 0.999896680 THE N.C. LAMBERT GRID BEARING AND LOCALIZED HORIZONTAL GROUND DISTANCE FROM "BL-2" TO -L- 10+00.00 STATION IS N 81° 23' 6.92" W 340.0718' ALL LINEAR DIMENSIONS ARE LOCALIZED HORIZONTAL DISTANCES VERTICAL DATUM USED IS NAVD 88

CENTERLINE COORDINATE LIST

POINT	STATION	NORTHING	EASTING
POT	10+00.00	682199.5373	2672645.3429
PC	11+37.33	682171.1836	2672779.7137
BEG	12+00.00	682158.6291	2672841.1132
PCC	12+60.05	682147.3218	2672900.0917
END	14+00.00	682127.5545	2673038.5948
PT	15+32.71	682119.5170	2673171.0311
POT	16+01.20	682118.0710	2673239.4990

**PROFILE**

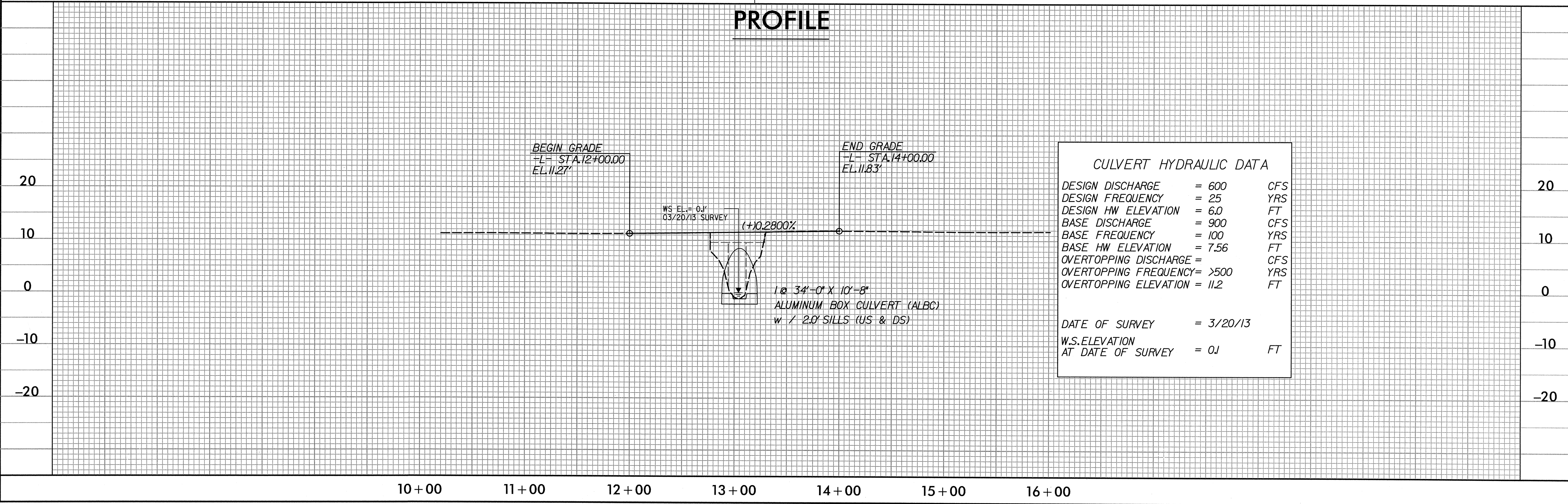

**CULVERT HYDRAULIC DATA**

DESIGN DISCHARGE	= 600	CFS
DESIGN FREQUENCY	= 25	YRS
DESIGN HW ELEVATION	= 6.0	FT
BASE DISCHARGE	= 900	CFS
BASE FREQUENCY	= 100	YRS
BASE HW ELEVATION	= 7.56	FT
OVERTOPPING DISCHARGE	=	CFS
OVERTOPPING FREQUENCY	= >500	YRS
OVERTOPPING ELEVATION	= 11.2	FT
DATE OF SURVEY	= 3/20/13	
W.S. ELEVATION AT DATE OF SURVEY	= 0.1	FT

REVISIONS

12/11/2013 12:42:06 PM ...\\P\01\060161\_rdy\_psh\_s04.dgn



STATE OF NORTH CAROLINA  
DIVISION OF HIGHWAYS

**TRANSPORTATION MANAGEMENT PLAN**

**BEAUFORT COUNTY**

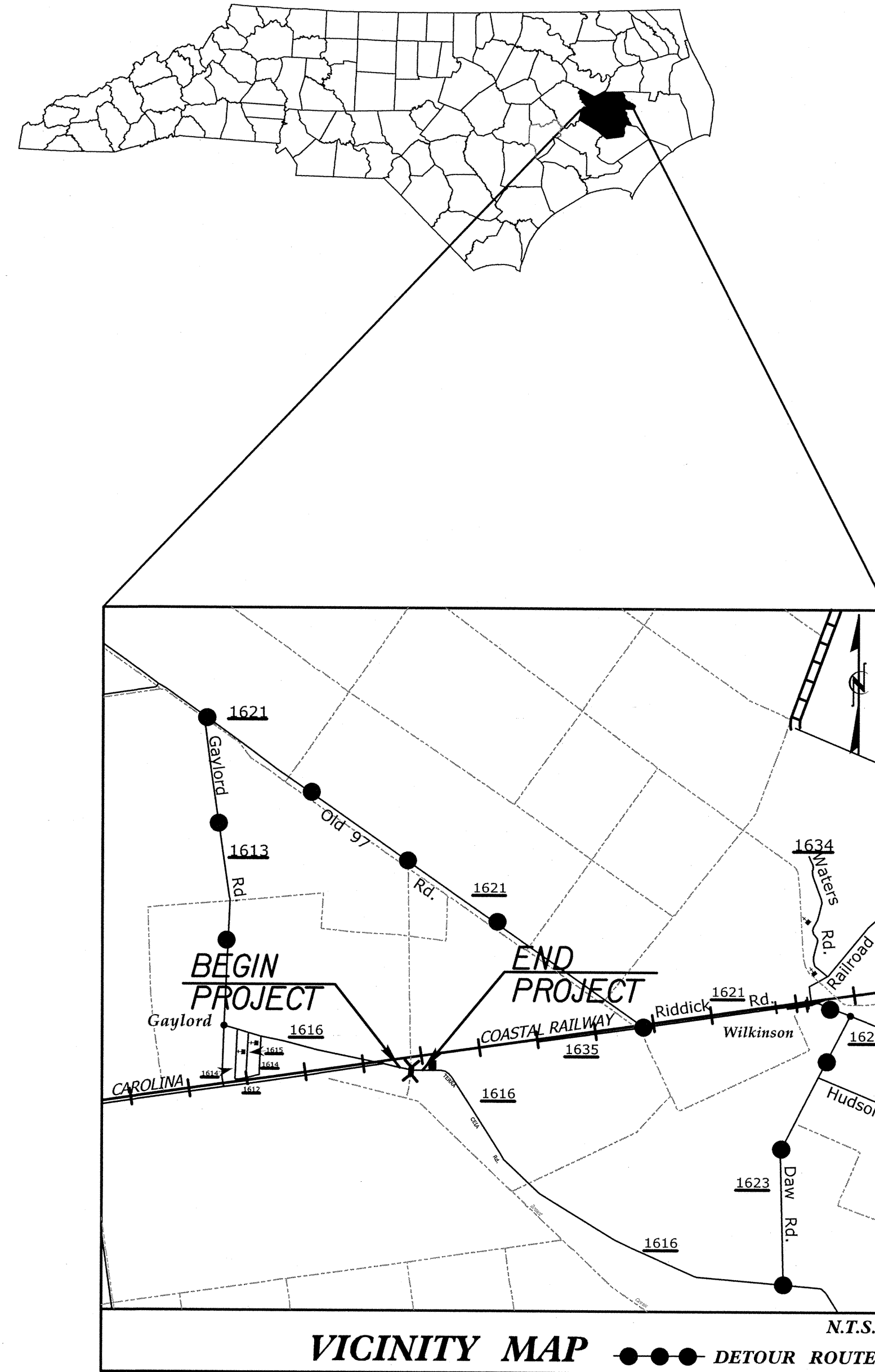

SHEET NO. TMP-1

**INDEX OF SHEETS**

SHEET NO.	TITLE
TMP-1	TITLE SHEET WITH VICINITY MAP & INDEX OF SHEETS, LIST OF APPLICABLE ROADWAY STANDARD DRAWINGS, AND LEGEND
TMP-2	PROJECT NOTES, DETOUR AND PLANS.

**ROADWAY STANDARD DRAWINGS**

THE FOLLOWING ROADWAY STANDARDS AS SHOWN IN "ROADWAY STANDARD DRAWINGS" PROJECT SERVICES UNIT - N.C. DEPARTMENT OF TRANSPORTATION - RALEIGH, N.C. DATED JAN 2012 ARE APPLICABLE TO THIS PROJECT AND BY REFERENCE HEREBY ARE CONSIDERED A PART OF THESE PLANS:

STD. NO.	TITLE
1101.11	TRAFFIC CONTROL DESIGN TABLES
1110.11	STATIONARY WORK ZONE SIGNS
1130.01	DRUMS
1145.01	BARRICADES
1150.01	FLAGGERS

**LEGEND**

- GENERAL**
- ← DIRECTION OF TRAFFIC FLOW
  - ↔ DIRECTION OF PEDESTRIAN TRAFFIC FLOW
  - EXIST. PVMT.
  - NORTH ARROW
  - PROPOSED PVMT.
  - WORK AREA
- TRAFFIC CONTROL DEVICES**
- ▩ BARRICADE (TYPE III)

**HNTB** HNTB NORTH CAROLINA, P.C.  
343 E. Six Forks Road, Suite 200  
Raleigh, North Carolina 27609  
NC License No: C-1554

R. B. EARLY, PE \_\_\_\_\_ TRAFFIC CONTROL PROJECT ENGINEER  
R. B. EARLY, PE \_\_\_\_\_ TRAFFIC CONTROL PROJECT DESIGN ENGINEER  
J. A. PHILLIPS \_\_\_\_\_ TRAFFIC CONTROL DESIGN ENGINEER

APPROVED: *[Signature]*  
DATE: 12-10-13

SEAL

**WORK ZONE SAFETY & MOBILITY**  
"from the MOUNTAINS to the COAST"

**N.C.D.O.T. WORK ZONE TRAFFIC CONTROL**  
1561 MAIL SERVICE CENTER (MSC) RALEIGH, NC 27699-1561  
750 N. GREENFIELD PARKWAY, GARNER, NC 27529 (DELIVERY)  
PHONE: (919) 773-2800 FAX: (919) 771-2745

STEVEN HAMILTON, PE DIVISION TRAFFIC ENGINEER

17BP.2.R.53  
TIP PROJECT:

10:27:41 AM  
C:\TCP\BR161\_tc\_tcp\_01\_title.dgn  
\$\$\$\$\$USERNAME\$\$\$\$\$



# GENERAL NOTES

IMPLEMENT TRAFFIC CONTROL IN ACCORDANCE WITH THE ROADWAY STANDARD DRAWINGS LISTED ON TMP-1.

CHANGES MAY BE REQUIRED WHEN PHYSICAL DIMENSIONS IN THE DETAIL DRAWINGS, STANDARD DETAILS AND ROADWAY DETAILS ARE NOT ATTAINABLE TO MEET FIELD CONDITIONS, OR RESULT IN DUPLICATE, OR UNDESIRABLE OVERLAPPING, OF DEVICES. MODIFICATIONS MAY INCLUDE: MOVING, SUPPLEMENTING, COVERING OR REMOVAL OF DEVICES, AS DIRECTED BY THE ENGINEER.

STATE FORCES WILL INSTALL AND MAINTAIN THE PROJECT DETOUR AND THE TYPE III BARRICADES AT THE PROJECT LIMITS.  
STATE FORCES WILL INSTALL PAINT AND MARKERS ON THE FINISHED PROJECT.  
CALL JIM EVANS AT 252-830-3493 FOR COORDINATION.

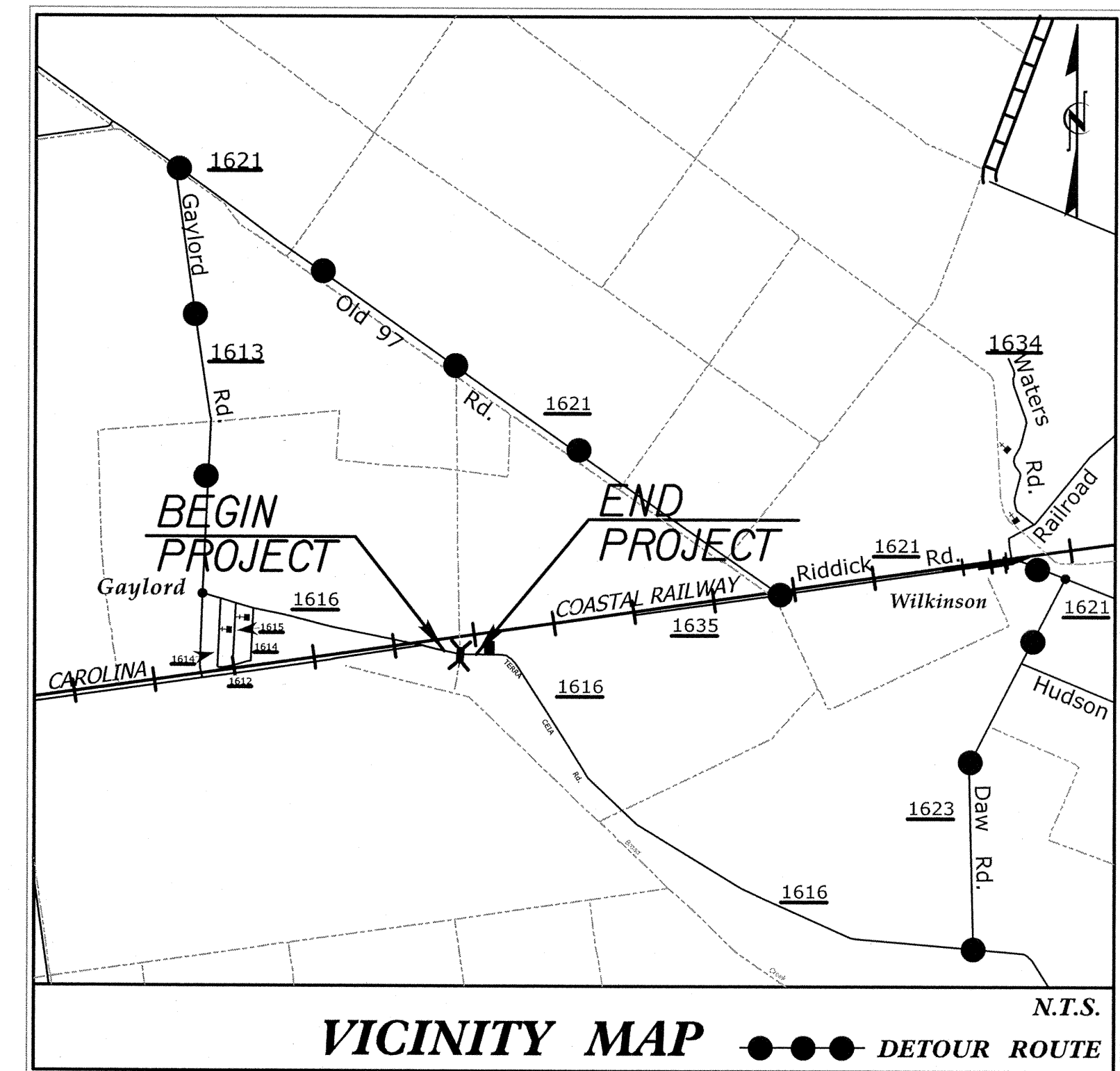

**BEGIN PROJECT 17BP.2.R.53**  
**BEGIN CONSTRUCTION**  
-L- STA. 12+00.00

**END PROJECT 17BP.2.R.53**  
**END CONSTRUCTION**  
-L- STA. 14+00.00

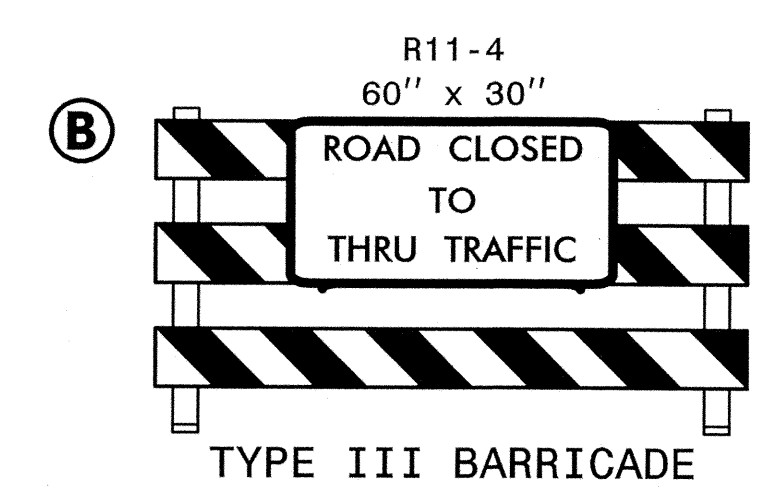
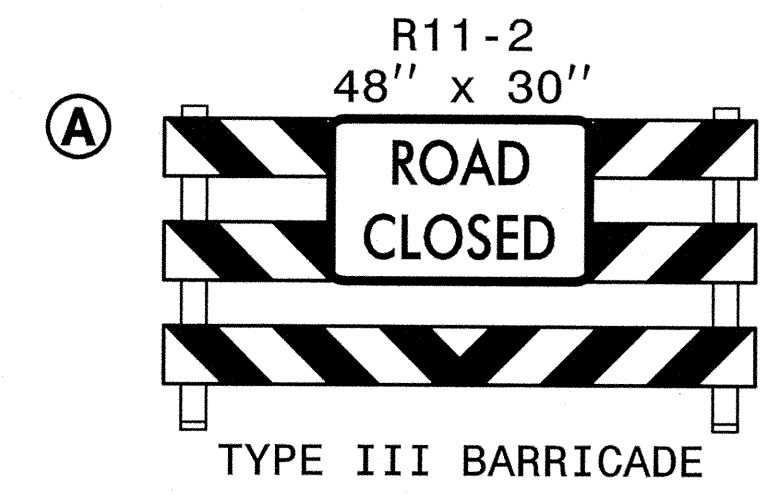
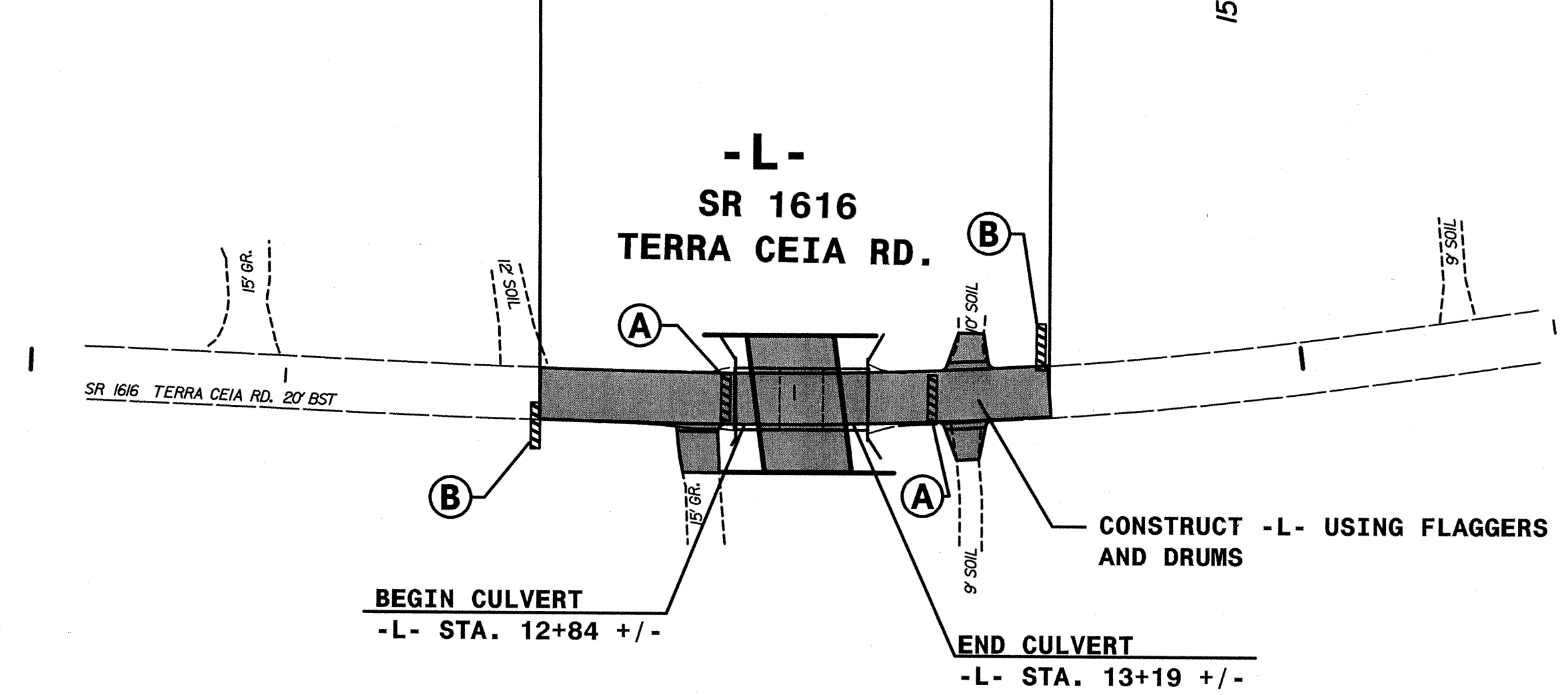

**BEGIN CULVERT**  
-L- STA. 12+84 +/-

**END CULVERT**  
-L- STA. 13+19 +/-

**CONSTRUCT -L- USING FLAGGERS AND DRUMS**

10/29/2013 10:29 AM C:\Users\j... \Public\17BP.2.R.53\17BP.2.R.53.dgn

REVISIONS

REVIEW: \_\_\_\_\_  
CONCUR: \_\_\_\_\_  
REVISE: \_\_\_\_\_  
VERIFY: \_\_\_\_\_

**HNTB** HNTB NORTH CAROLINA, P.C.  
343 E. Six Forks Road, Suite 200  
Raleigh, North Carolina 27609  
NC License No: C-1554

APPROVED: *Phonda B. Early* DATE: 12-10-13

SEAL  
NORTH CAROLINA PROFESSIONAL ENGINEER  
PHONDA B. EARLY  
023921

DIVISION OF HIGHWAYS  
STATE OF NORTH CAROLINA  
DEPARTMENT OF TRANSPORTATION  
WORK ZONE TRAFFIC CONTROL

TRANSPORTATION MANAGEMENT PLAN  
GENERAL NOTES,  
DETOUR  
AND DETAIL

STATE	STATE PROJECT REFERENCE NO.	SHEET NO.	TOTAL SHEETS
N.C.	17BP.2.R.53	EC-1	7
STATE PROJ. NO.	F.A. PROJ. NO.	DESCRIPTION	

STATE OF NORTH CAROLINA  
DIVISION OF HIGHWAYS

---

PLAN FOR PROPOSED  
HIGHWAY EROSION CONTROL

---

**LOCATION: BRIDGE NO. 161 OVER BROAD CREEK CANAL  
ON SR 1616 (TERRA CEIA RD.)**

**TYPE OF WORK: GRADING, PAVING, DRAINAGE & CULVERT**

**EROSION AND SEDIMENT CONTROL MEASURES**

Std. #	Description	Symbol
1630.03	Temporary Silt Ditch	— m —
1630.05	Temporary Diversion	— m —
1605.01	Temporary Silt Fence	
1606.01	Special Sediment Control Fence	▲▲▲▲▲▲▲▲
1622.01	Temporary Berms and Slope Drains	— m —
1630.01	Silt Basin Type B	▨
1633.01	Temporary Rock Silt Check Type-A	▨
	Temporary Rock Silt Check Type-A with Matting and Polyacrylamide (PAM)	▨
	Temporary Rock Silt Check Type-B	▨
	Wattle / Coir Fiber Wattle	— m —
	Wattle / Coir Fiber Wattle with Polyacrylamide (PAM)	— m —
1634.01	Temporary Rock Sediment Dam Type-A	▨
1634.02	Temporary Rock Sediment Dam Type-B	▨
1635.01	Rock Pipe Inlet Sediment Trap Type-A	⊓
1635.02	Rock Pipe Inlet Sediment Trap Type-B	⊓
1630.04	Stilling Basin	▭
1630.06	Special Stilling Basin	▭
	Rock Inlet Sediment Trap:	
1632.01	Type A	A
1632.02	Type B	B
1632.03	Type C	C
	Skimmer Basin	▭
	Tiered Skimmer Basin	▭
	Infiltration Basin	▭

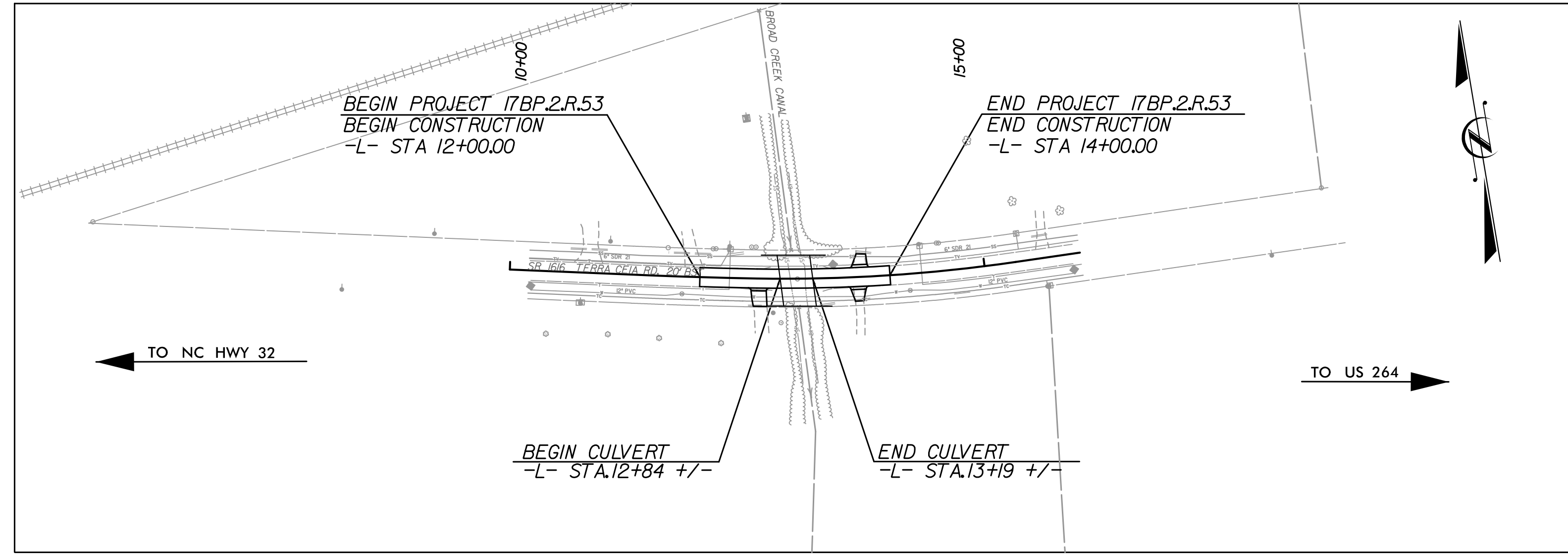

THIS PROJECT HAS  
BEEN DESIGNED TO  
SENSITIVE WATERSHED  
STANDARDS.

ENVIRONMENTALLY  
SENSITIVE AREA(S) EXIST  
ON THIS PROJECT

*Refer To E. C. Special Provisions  
for Special Considerations.*

**TIP PROJECT: 17BP.2.R.53**

**GRAPHIC SCALE**

0  
[Scale Bar]  
PLANS

0  
[Scale Bar]  
PROFILE (HORIZONTAL)

0  
[Scale Bar]  
PROFILE (VERTICAL)

ROADSIDE ENVIRONMENTAL UNIT  
DIVISION OF HIGHWAYS  
STATE OF NORTH CAROLINA

THESE EROSION AND SEDIMENT CONTROL PLANS COMPLY WITH THE REGULATIONS SET FORTH BY THE NCG-010000 GENERAL CONSTRUCTION PERMIT EFFECTIVE AUGUST 3, 2011 ISSUED BY THE NORTH CAROLINA DEPARTMENT OF ENVIRONMENT AND NATURAL RESOURCES DIVISION OF WATER QUALITY.

Prepared In the Office of:

**HNTB** HNTB NORTH CAROLINA, P.C.  
343 E. Six Forks Road, Suite 200  
Raleigh, North Carolina 27609  
NC License No: C-1554

---

**2012 STANDARD SPECIFICATIONS**

JOHN F. WATSON  
EROSION CONTROL  
LEVEL III-A  
CERTIFICATION #3419

Roadway Standard Drawings

The following roadway english standards as appear in "Roadway Standard Drawings"- Roadway Design Unit - N. C. Department of Transportation - Raleigh, N. C., dated January 2012 and the latest revision thereto are applicable to this project and by reference hereby are considered a part of these plans.

1604.01 Railroad Erosion Control Detail	1632.01 Rock Inlet Sediment Trap Type A
1605.01 Temporary Silt Fence	1632.02 Rock Inlet Sediment Trap Type B
1606.01 Special Sediment Control Fence	1632.03 Rock Inlet Sediment Trap Type C
1607.01 Gravel Construction Entrance	1633.01 Temporary Rock Silt Check Type A
1622.01 Temporary Berms and Slope Drains	1633.02 Temporary Rock Silt Check Type B
1630.01 Riser Basin	1634.01 Temporary Rock Sediment Dam Type A
1630.02 Silt Basin Type B	1634.02 Temporary Rock Sediment Dam Type B
1630.03 Temporary Silt Ditch	1635.01 Rock Pipe Inlet Sediment Trap Type A
1630.04 Stilling Basin	1635.02 Rock Pipe Inlet Sediment Trap Type B
1630.05 Temporary Diversion	1640.01 Coir Fiber Baffle
1630.06 Special Stilling Basin	1645.01 Temporary Stream Crossing
1631.01 Matting Installation	

210113 P:\Mg\17BP.2.R.53\ec\_tsh.dgn  
\*\*\*\*\*USERNAME\*\*\*\*\*

# COIR FIBER WATTLE WITH POLYACRYLAMIDE (PAM) DETAIL

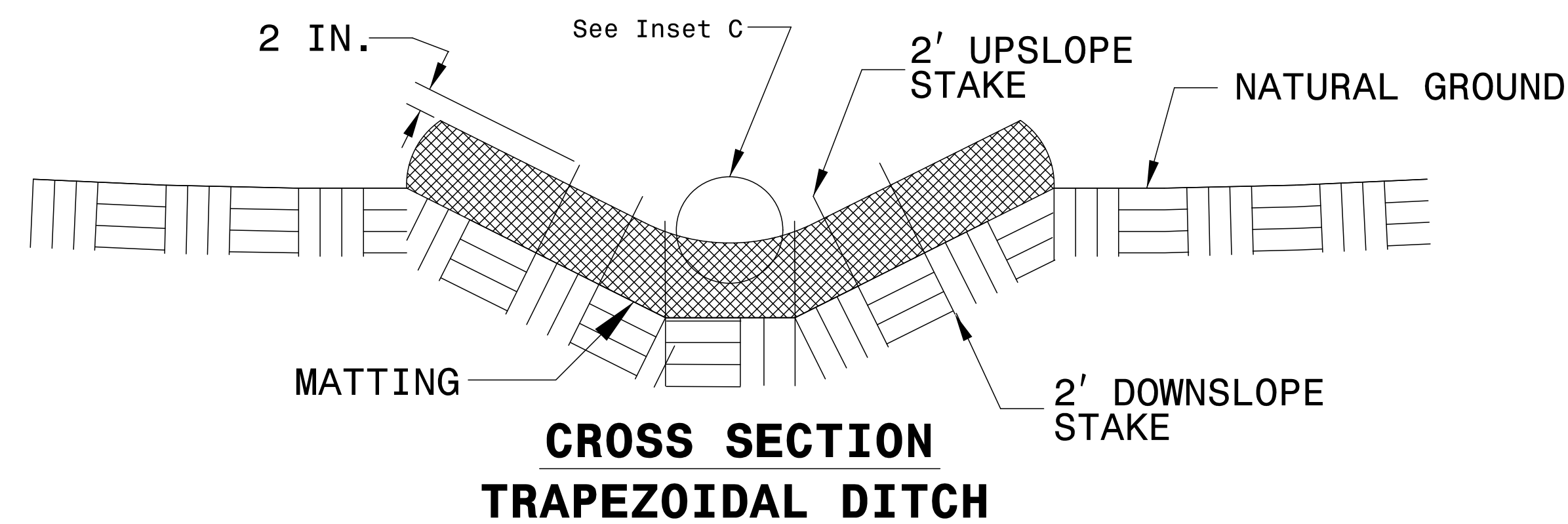
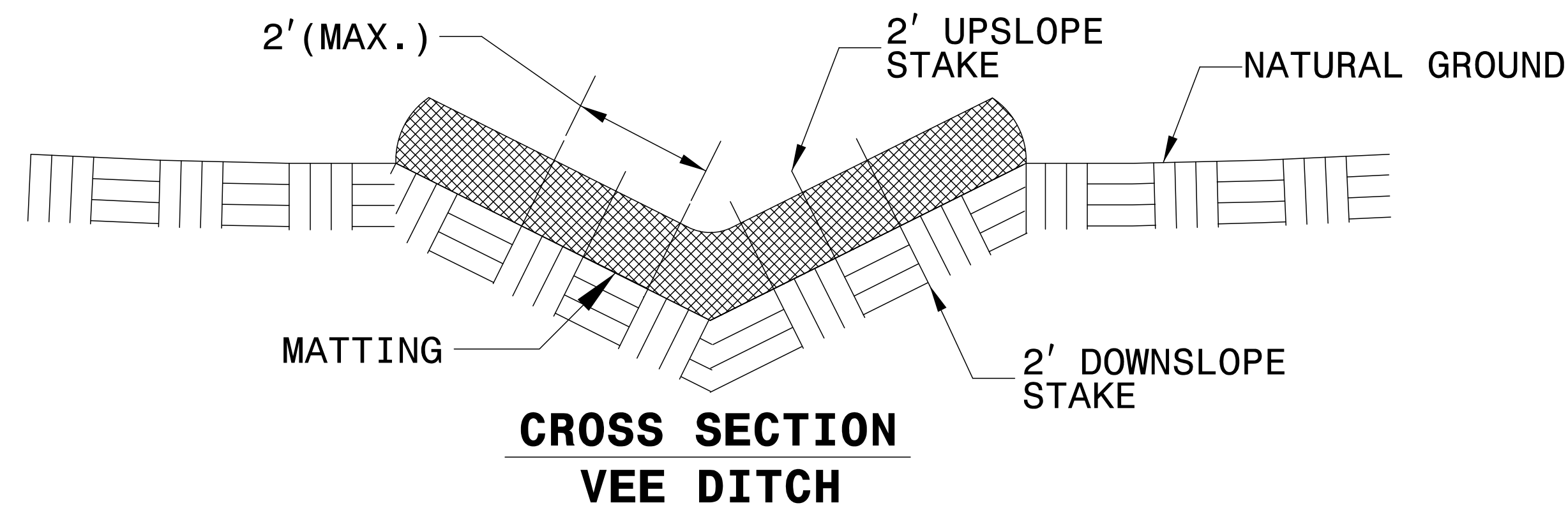
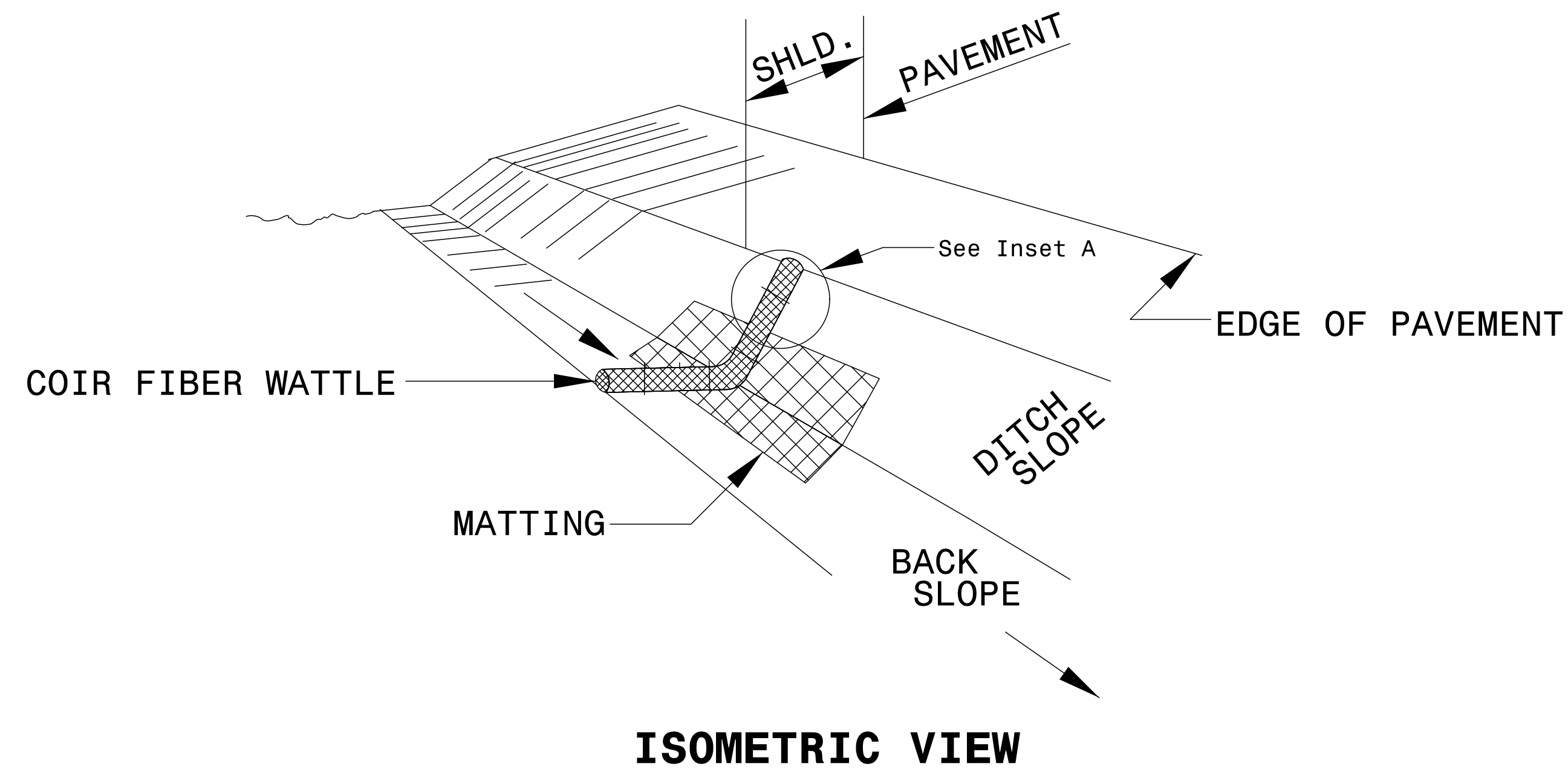

**NOTES:**

USE MINIMUM 12 IN. DIAMETER COIR FIBER (COCONUT FIBER) WATTLE.

USE 2 FT. WOODEN STAKES WITH A 2 IN. BY 2 IN. NOMINAL CROSS SECTION.

ONLY INSTALL WATTLE(S) TO A HEIGHT IN DITCH SO FLOW WILL NOT WASH AROUND WATTLE AND SCOUR DITCH SLOPES AND AS DIRECTED.

INSTALL A MINIMUM OF 2 UPSLOPE STAKES AND 4 DOWNSLOPE STAKES AT AN ANGLE TO WEDGE WATTLE TO BOTTOM OF DITCH.

PROVIDE STAPLES MADE OF 0.125 IN. DIAMETER STEEL WIRE FORMED INTO A U SHAPE NOT LESS THAN 12" IN LENGTH.

INSTALL STAPLES APPROXIMATELY EVERY 1 LINEAR FOOT ON BOTH SIDES OF WATTLE AND AT EACH END TO SECURE IT TO THE SOIL.

INSTALL MATTING IN ACCORDANCE WITH SECTION 1631 OF THE STANDARD SPECIFICATIONS.

PRIOR TO POLYACRYLAMIDE (PAM) APPLICATION, OBTAIN A SOIL SAMPLE FROM PROJECT LOCATION, AND FROM OFFSITE MATERIAL, AND ANALYZE FOR APPROPRIATE PAM FLOCCULANT TO BE APPLIED TO EACH WATTLE.

INITIALLY APPLY 2 OUNCES OF ANIONIC OR NEUTRALLY CHARGED PAM OVER WATTLE WHERE WATER WILL FLOW AND 1 OUNCE OF PAM ON MATTING ON EACH SIDE OF WATTLE. REAPPLY PAM AFTER EVERY RAINFALL EVENT THAT IS EQUAL TO OR EXCEEDS 0.50 IN.

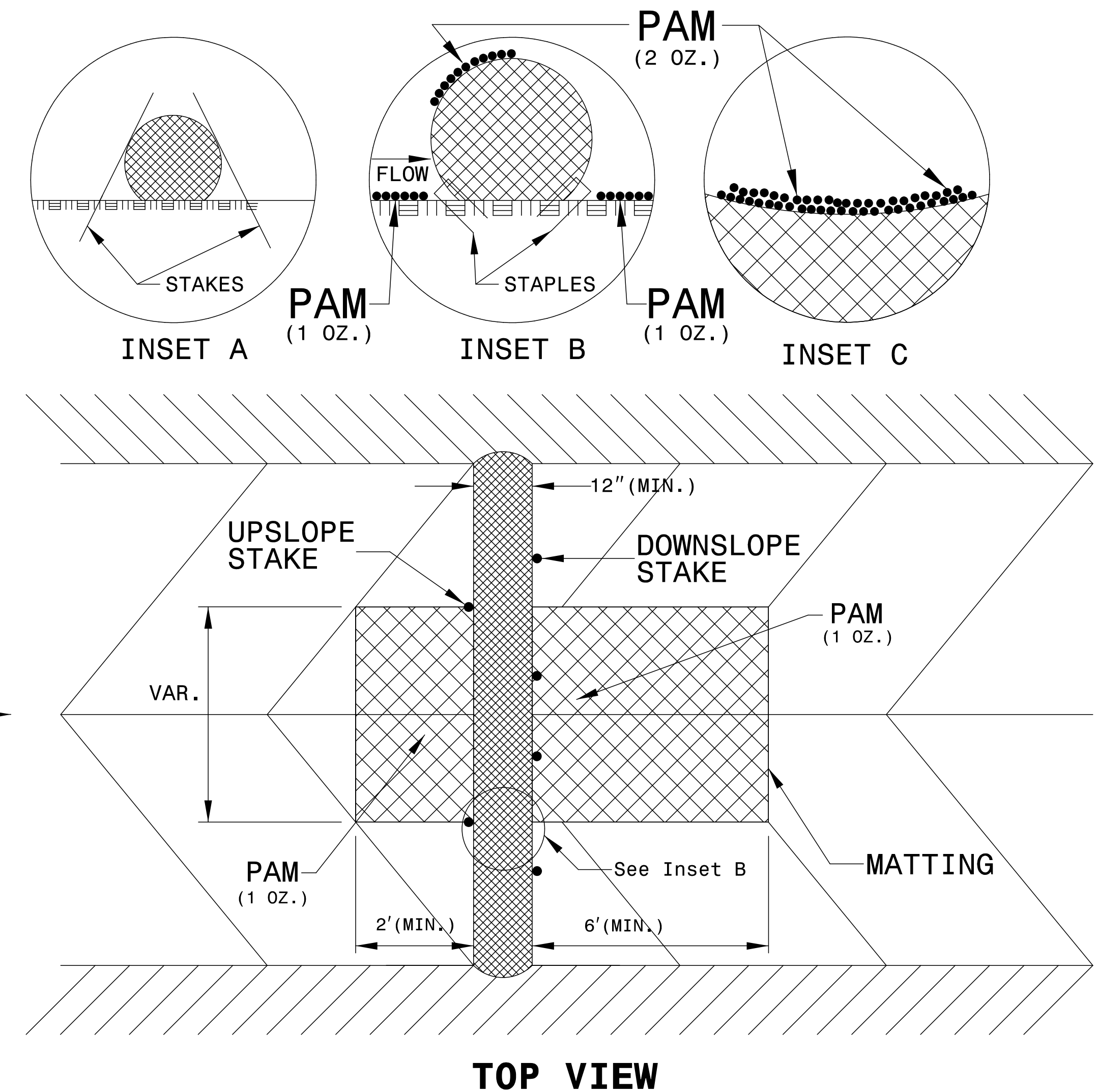

6/2/99 2:19:09 PM ec\_detail.dgn \\server\user\mfe\ec\ec.dwg



# SILT FENCE COIR FIBER WATTLE BREAK DETAIL

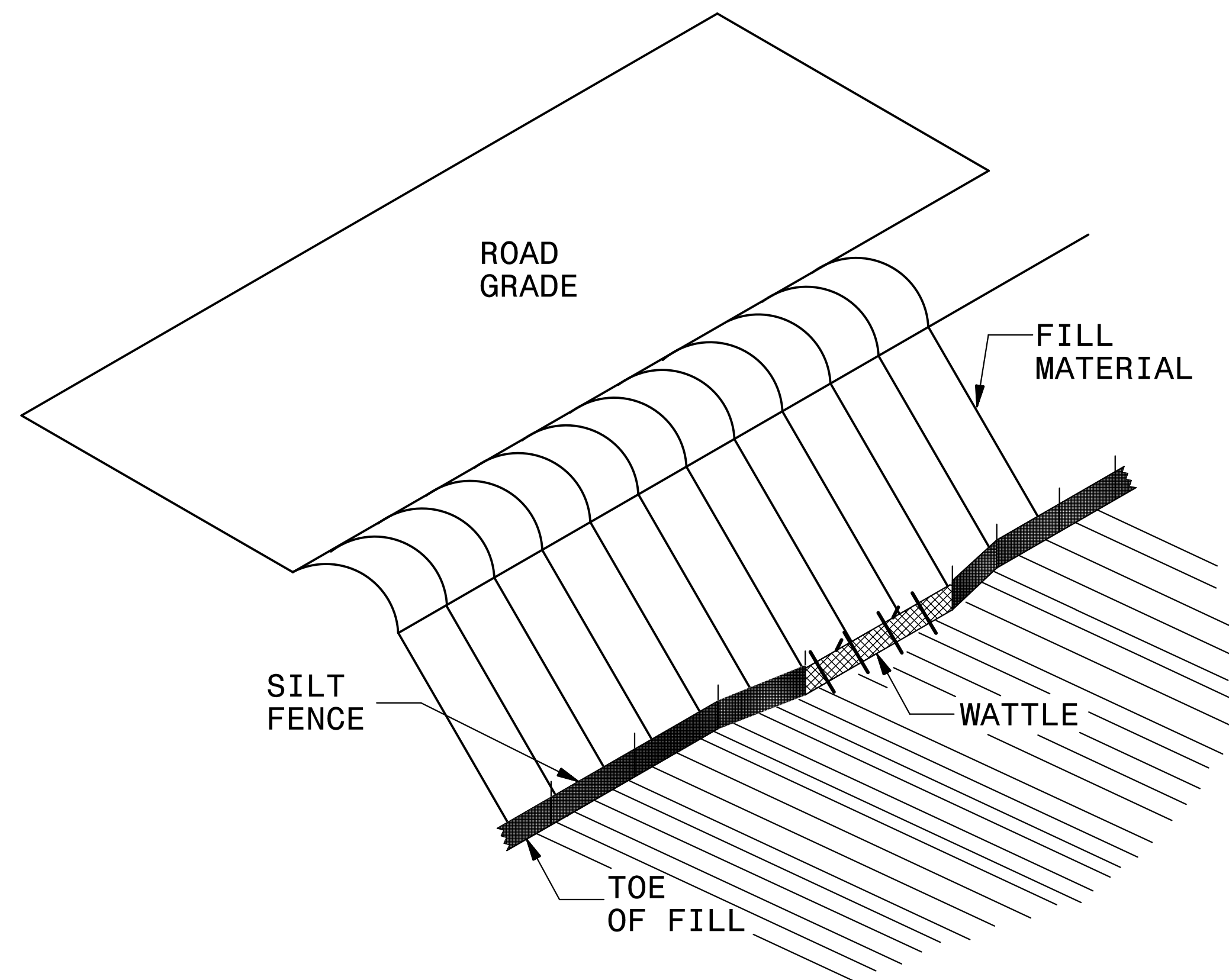

**ISOMETRIC VIEW**

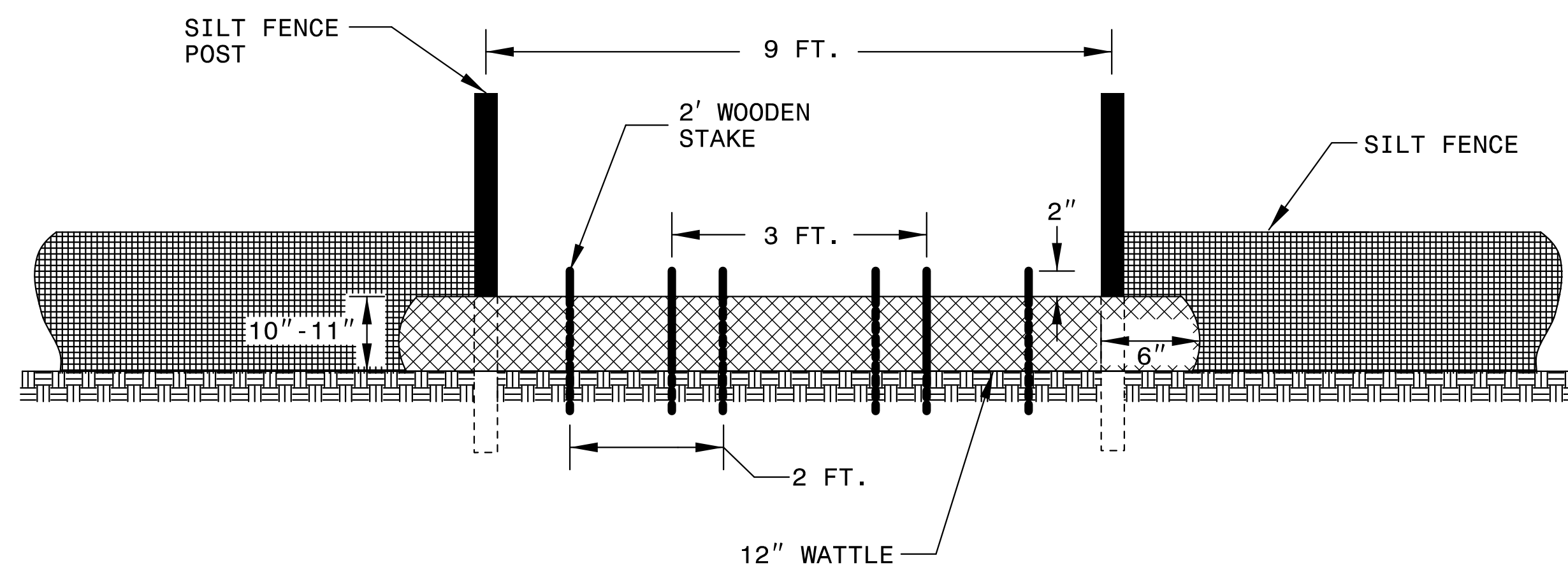

**VIEW FROM SLOPE**

**NOTES:**

USE MINIMUM 12 IN. DIAMETER COIR FIBER (COCONUT FIBER) WATTLE AND LENGTH OF 10 FT.

EXCAVATE A 1 TO 2 INCH TRENCH FOR WATTLE TO BE PLACED.

DO NOT PLACE WATTLE ON TOE OF SLOPE.

USE 2 FT. WOODEN STAKES WITH A 2 IN. BY 2 IN. NOMINAL CROSS SECTION.

INSTALL A MINIMUM OF 2 UPSLOPE STAKES AND 4 DOWNSLOPE STAKES AT AN ANGLE TO WEDGE WATTLE TO GROUND.

PROVIDE STAPLES MADE OF 0.125 IN. DIAMETER STEEL WIRE FORMED INTO A U SHAPE NOT LESS THAN 12" IN LENGTH.

INSTALL STAPLES APPROXIMATELY EVERY 1 LINEAR FOOT ON BOTH SIDES OF WATTLE AND AT EACH END TO SECURE IT TO THE SOIL.

WATTLE INSTALLATION CAN BE ON OUTSIDE OF THE SILT FENCE AS DIRECTED.

INSTALL TEMPORARY SILT FENCE IN ACCORDANCE WITH SECTION 1605 OF THE STANDARD SPECIFICATIONS.

**INSET A**

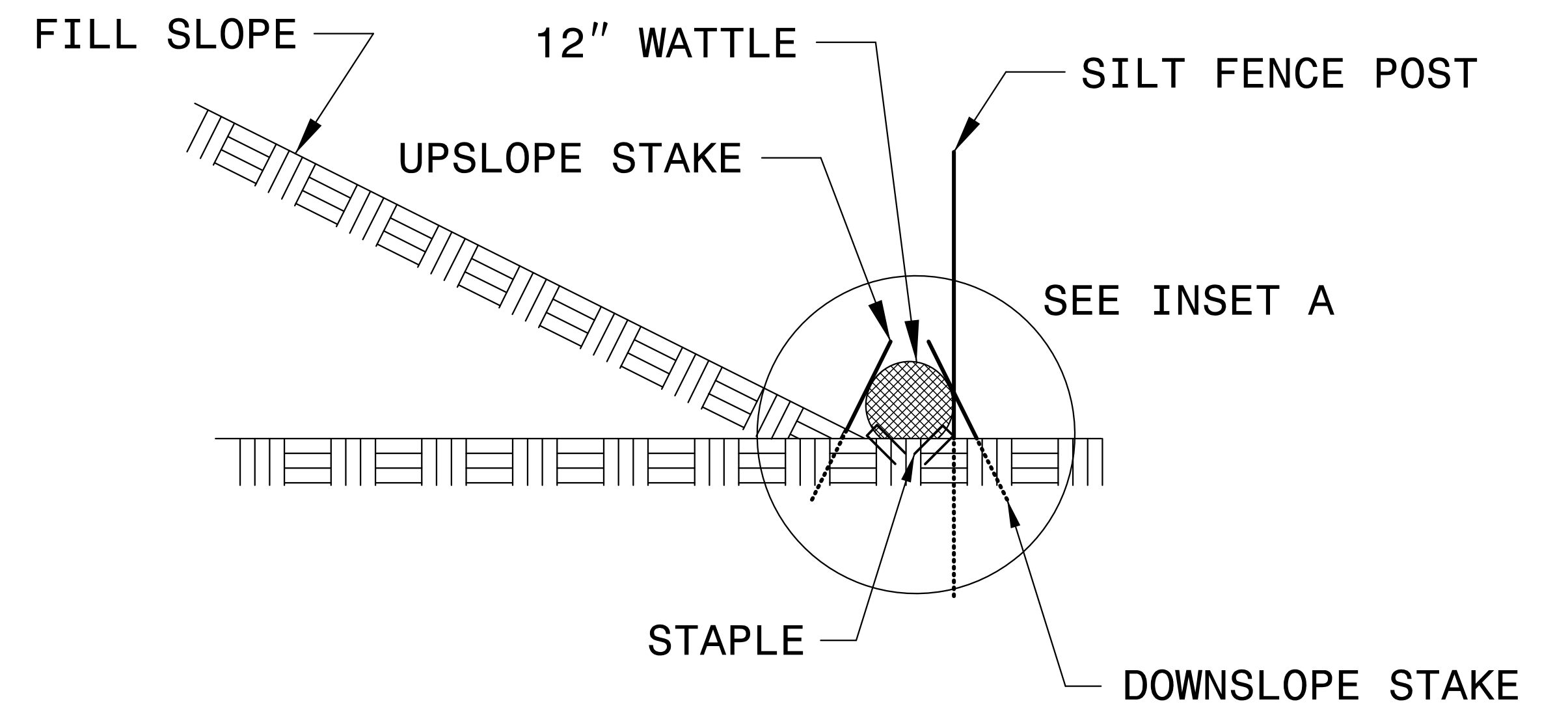
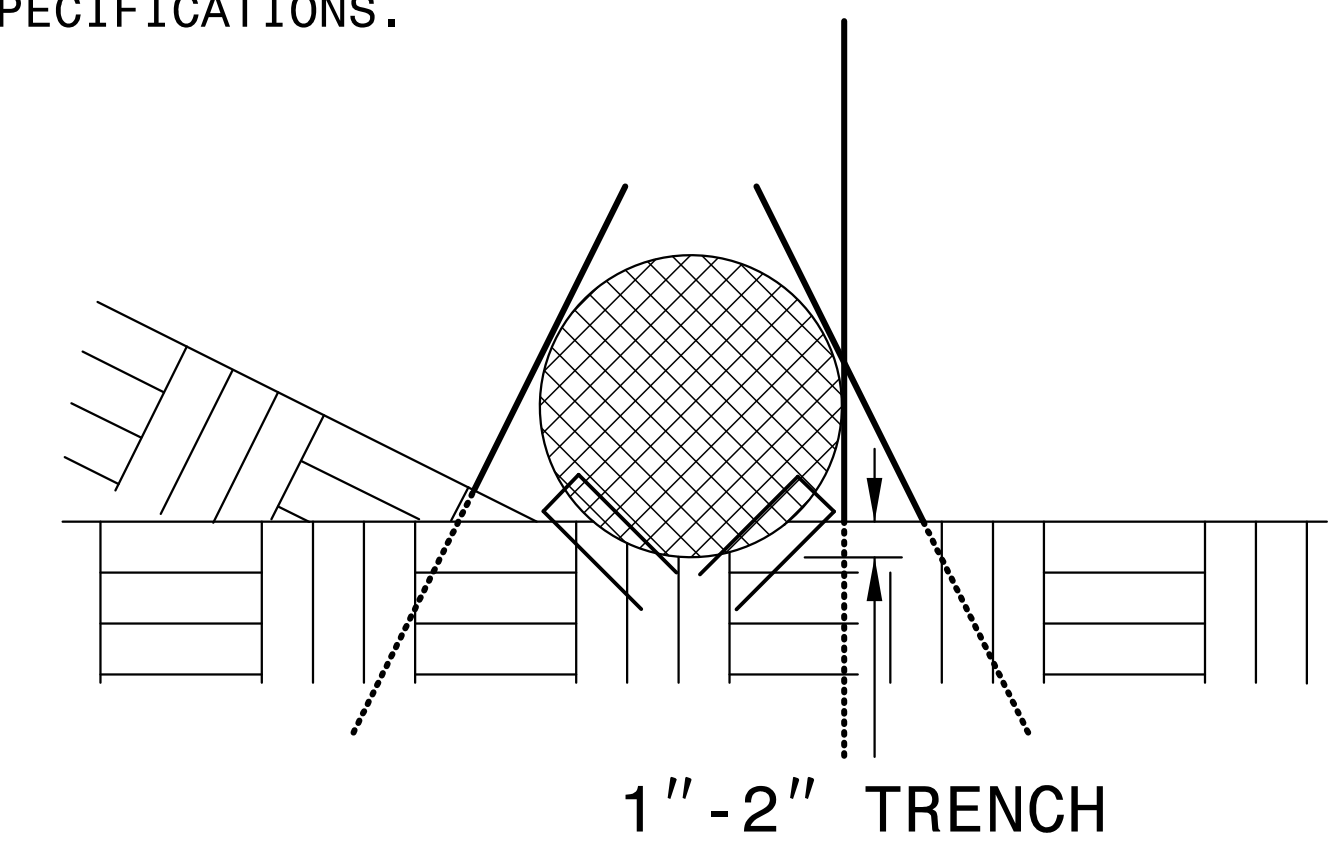

**SIDE VIEW**

# COIR FIBER WATTLE BARRIER DETAIL

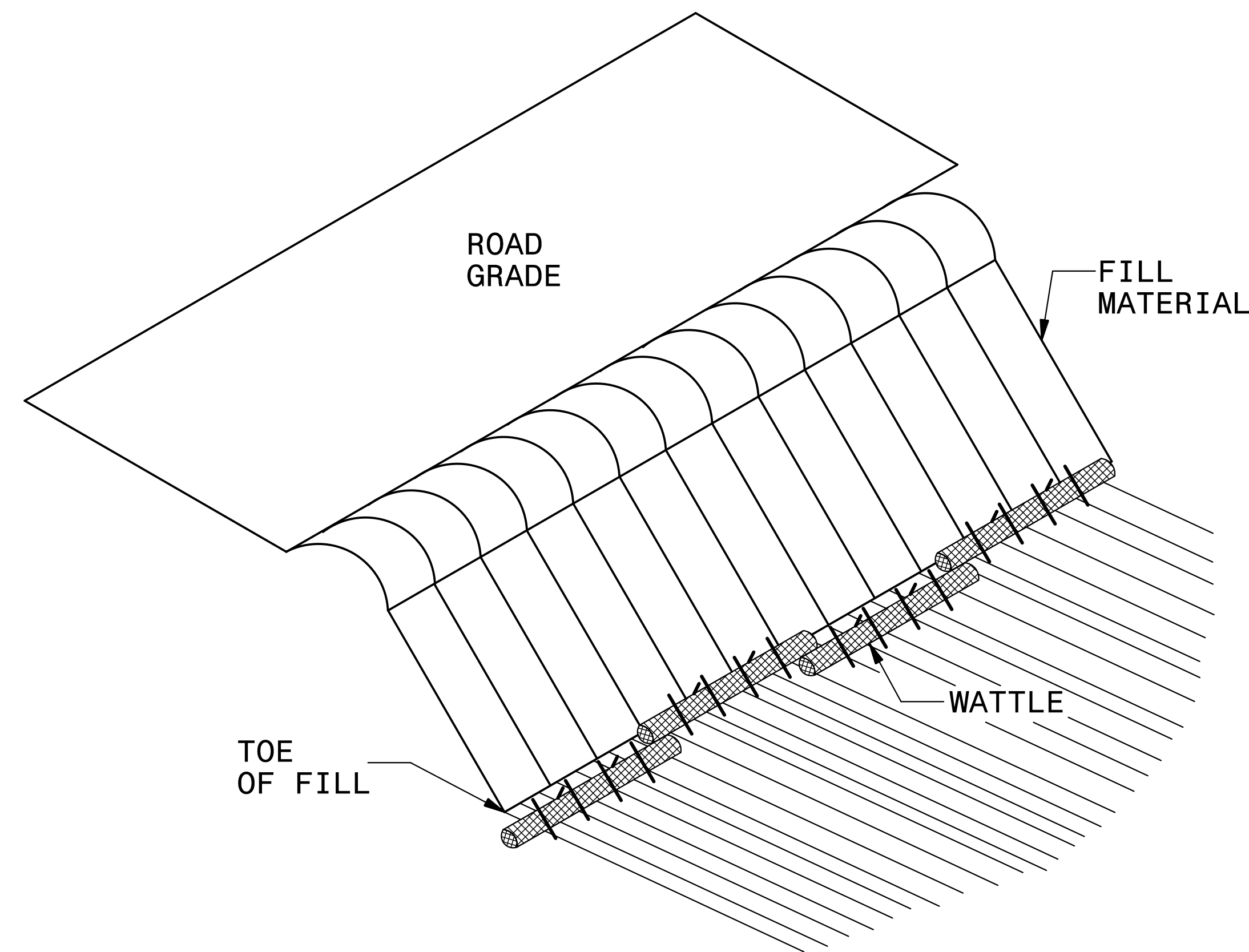

**ISOMETRIC VIEW**

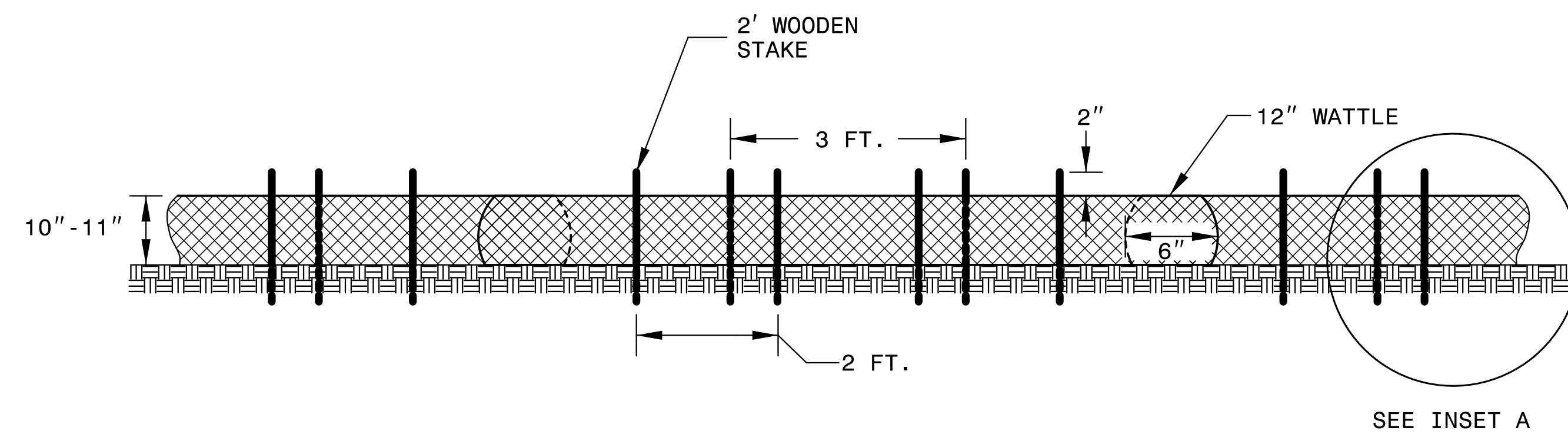

**FRONT VIEW**

**NOTES:**

USE MINIMUM 12 IN. DIAMETER COIR FIBER (COCONUT) WATTLE AND LENGTH OF 10 FT.

EXCAVATE A 1 TO 2 INCH TRENCH FOR WATTLE TO BE PLACED.

DO NOT PLACE WATTLES ON TOE OF SLOPE.

USE 2 FT. WOODEN STAKES WITH A 2 IN. BY 2 IN. NOMINAL CROSS SECTION.

INSTALL A MINIMUM OF 2 UPSLOPE STAKES AND 4 DOWNSLOPE STAKES AT AN ANGLE TO WEDGE WATTLE TO GROUND.

PROVIDE STAPLES MADE OF 0.125 IN. DIAMETER STEEL WIRE FORMED INTO A U SHAPE NOT LESS THAN 12" IN LENGTH.

INSTALL STAPLES APPROXIMATELY EVERY 1 LINEAR FOOT ON BOTH SIDES OF WATTLE AND AT EACH END TO SECURE IT TO THE SOIL.

FOR BREAKS ALONG LARGE SLOPES, USE MAXIMUM SPACING OF 20 FT.

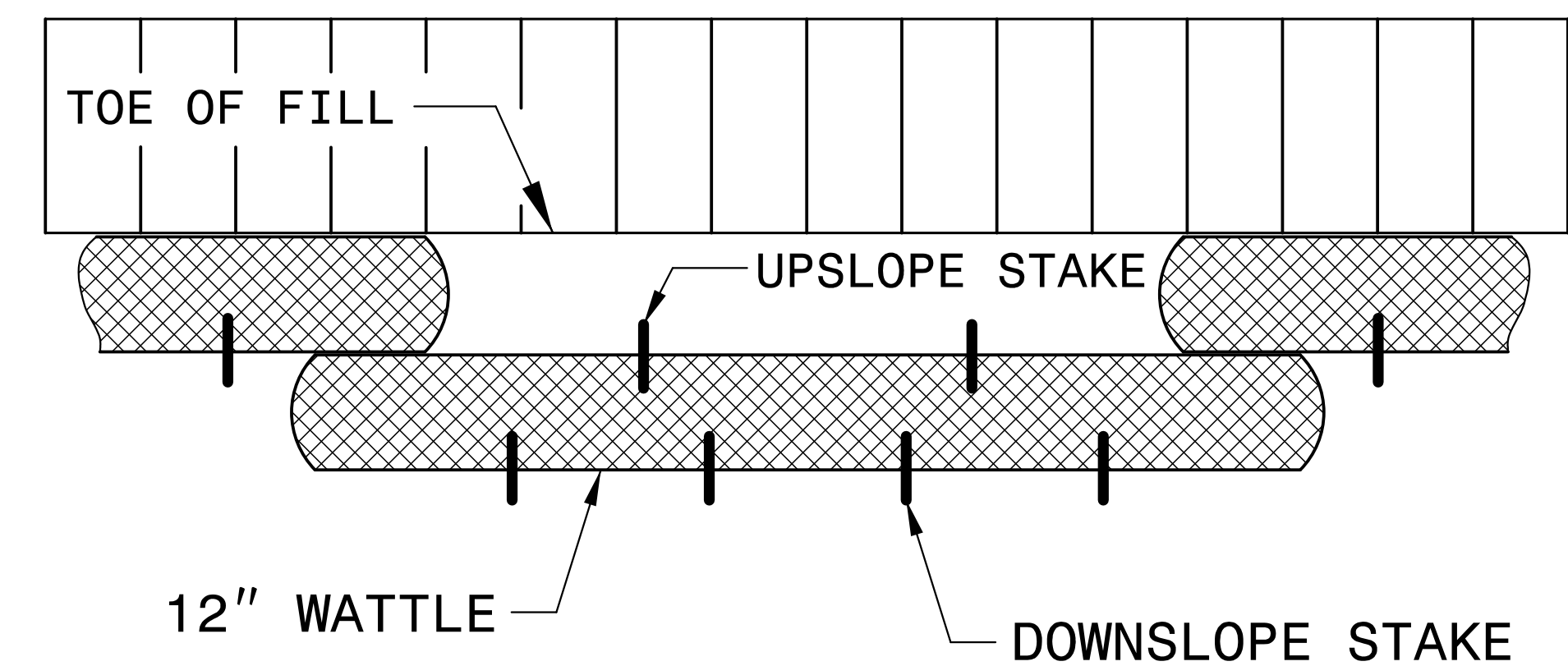
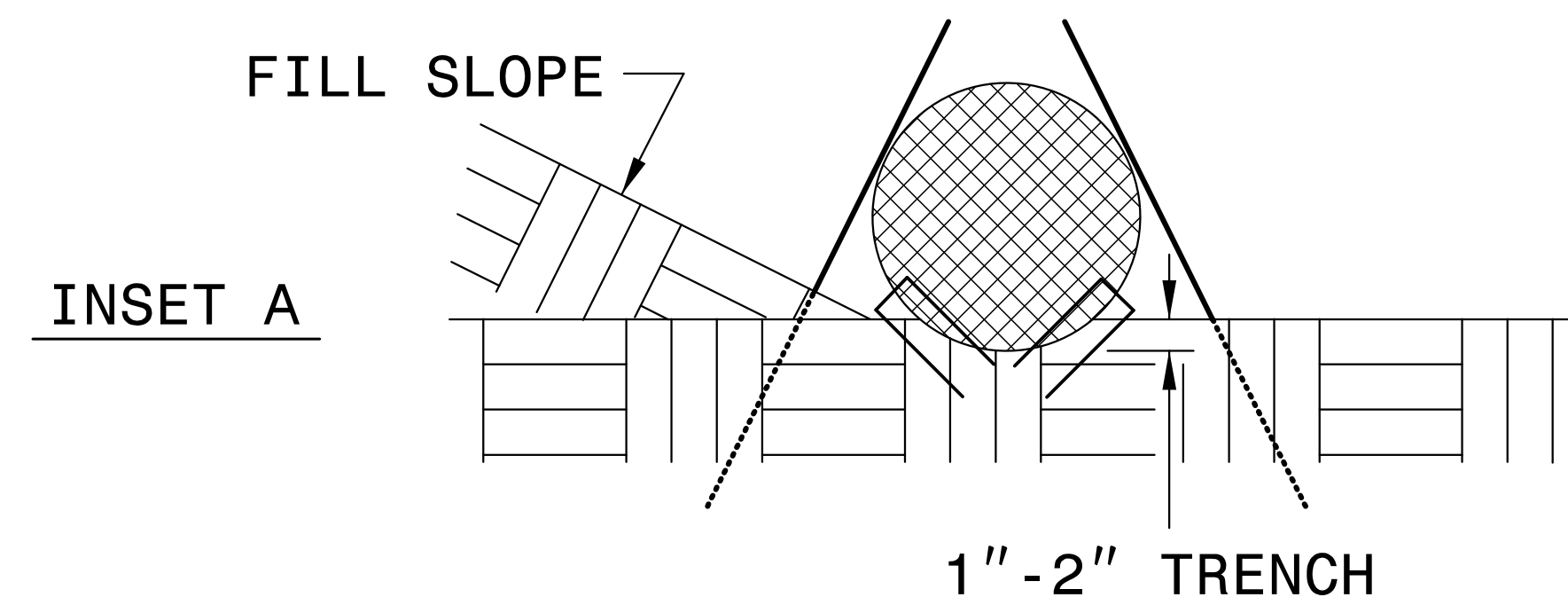

**TOP VIEW**

DIVISION OF HIGHWAYS  
STATE OF NORTH CAROLINA

---



---

## ***SOIL STABILIZATION TIMEFRAMES***

<i>SITE DESCRIPTION</i>	<i>STABILIZATION TIME</i>	<i>TIMEFRAME EXCEPTIONS</i>
PERIMETER DIKES, SWALES, DITCHES AND SLOPES	7 DAYS	NONE
HIGH QUALITY WATER (HQW) ZONES	7 DAYS	NONE
SLOPES STEEPER THAN 3:1	7 DAYS	IF SLOPES ARE 10' OR LESS IN LENGTH AND ARE NOT STEEPER THAN 2:1, 14 DAYS ARE ALLOWED.
SLOPES 3:1 OR FLATTER	14 DAYS	7 DAYS FOR SLOPES GREATER THAN 50' IN LENGTH.
ALL OTHER AREAS WITH SLOPES FLATTER THAN 4:1	14 DAYS	NONE, EXCEPT FOR PERIMETERS AND HQW ZONES.



JOHN F. WATSON  
 EROSION CONTROL  
 LEVEL III-A  
 CERTIFICATION #3419

**PLAN**

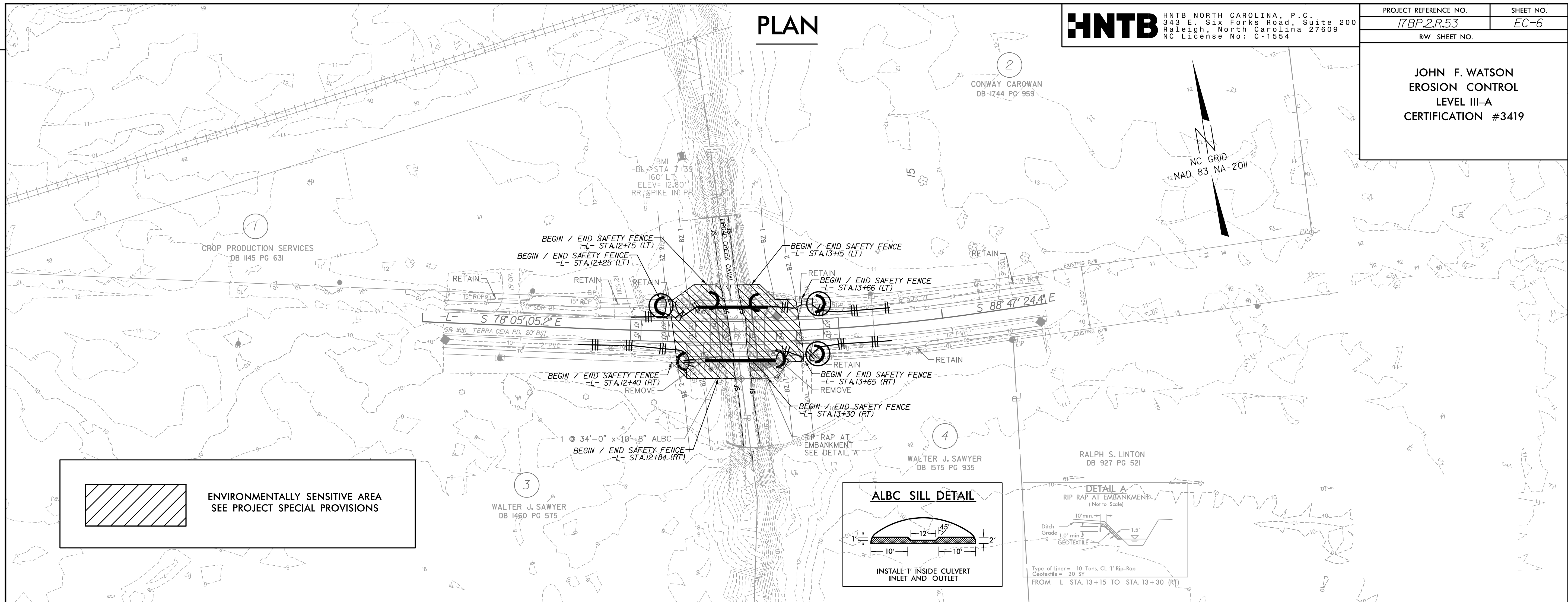

**PROFILE**

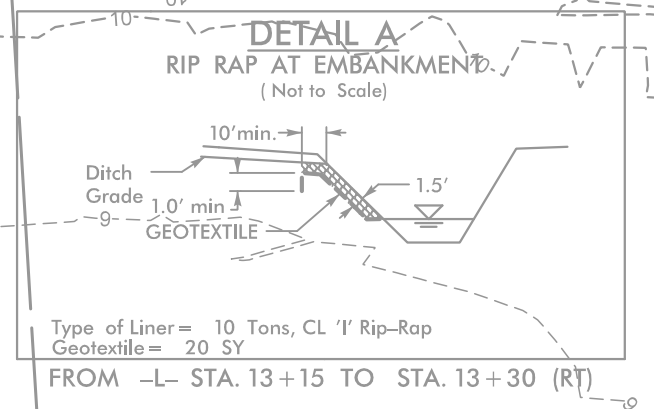
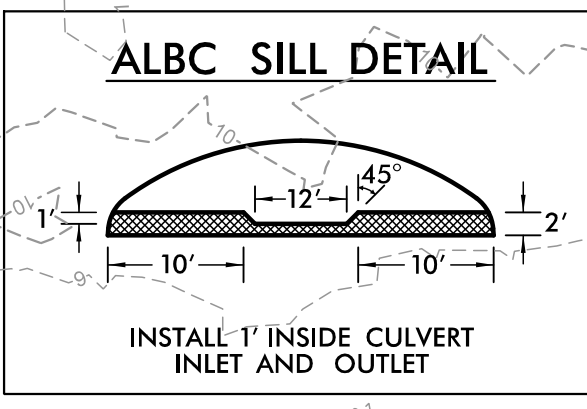
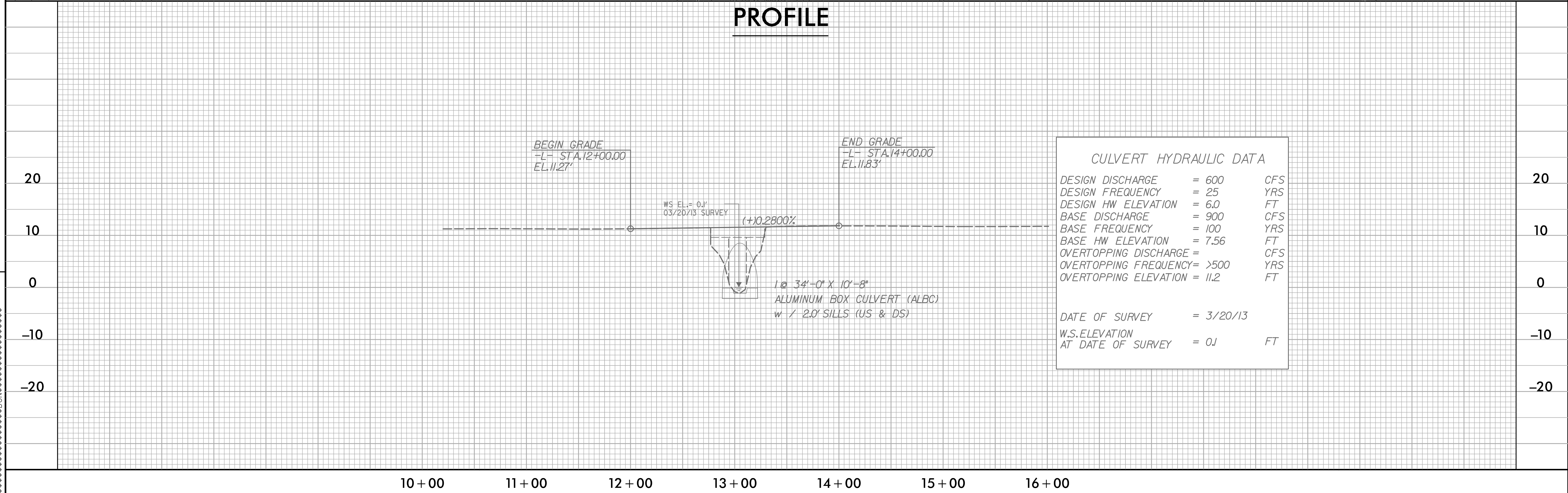

CULVERT HYDRAULIC DATA		
DESIGN DISCHARGE	= 600	CFS
DESIGN FREQUENCY	= 25	YRS
DESIGN HW ELEVATION	= 6.0	FT
BASE DISCHARGE	= 900	CFS
BASE FREQUENCY	= 100	YRS
BASE HW ELEVATION	= 7.56	FT
OVERTOPPING DISCHARGE	=	CFS
OVERTOPPING FREQUENCY	= >500	YRS
OVERTOPPING ELEVATION	= 11.2	FT
DATE OF SURVEY	= 3/20/13	
W.S.ELEVATION AT DATE OF SURVEY	= 0.1	FT

REVISIONS

\$\$\$\$DATE\$\$\$\$  
 \$\$\$SYTIME\$\$\$  
 \$\$\$SYTIME\$\$\$

10+00 11+00 12+00 13+00 14+00 15+00 16+00

# BEAUFORT COUNTY 0161 CULVERT PHASING BROAD CREEK CANAL

**HNTB** HNTB NORTH CAROLINA, P.C.  
343 E. Six Forks Road, Suite 200  
Raleigh, North Carolina 27609  
NC License No: C-1554

DATE: SEPTEMBER 10, 2013

PROJECT REFERENCE NO. SHEET NO.

17BP.2.R.53 EC-7

RW SHEET NO.

RAILROAD DESIGN ENGINEER HYDRAULICS ENGINEER

**PRELIMINARY PLANS**  
DO NOT USE FOR CONSTRUCTION

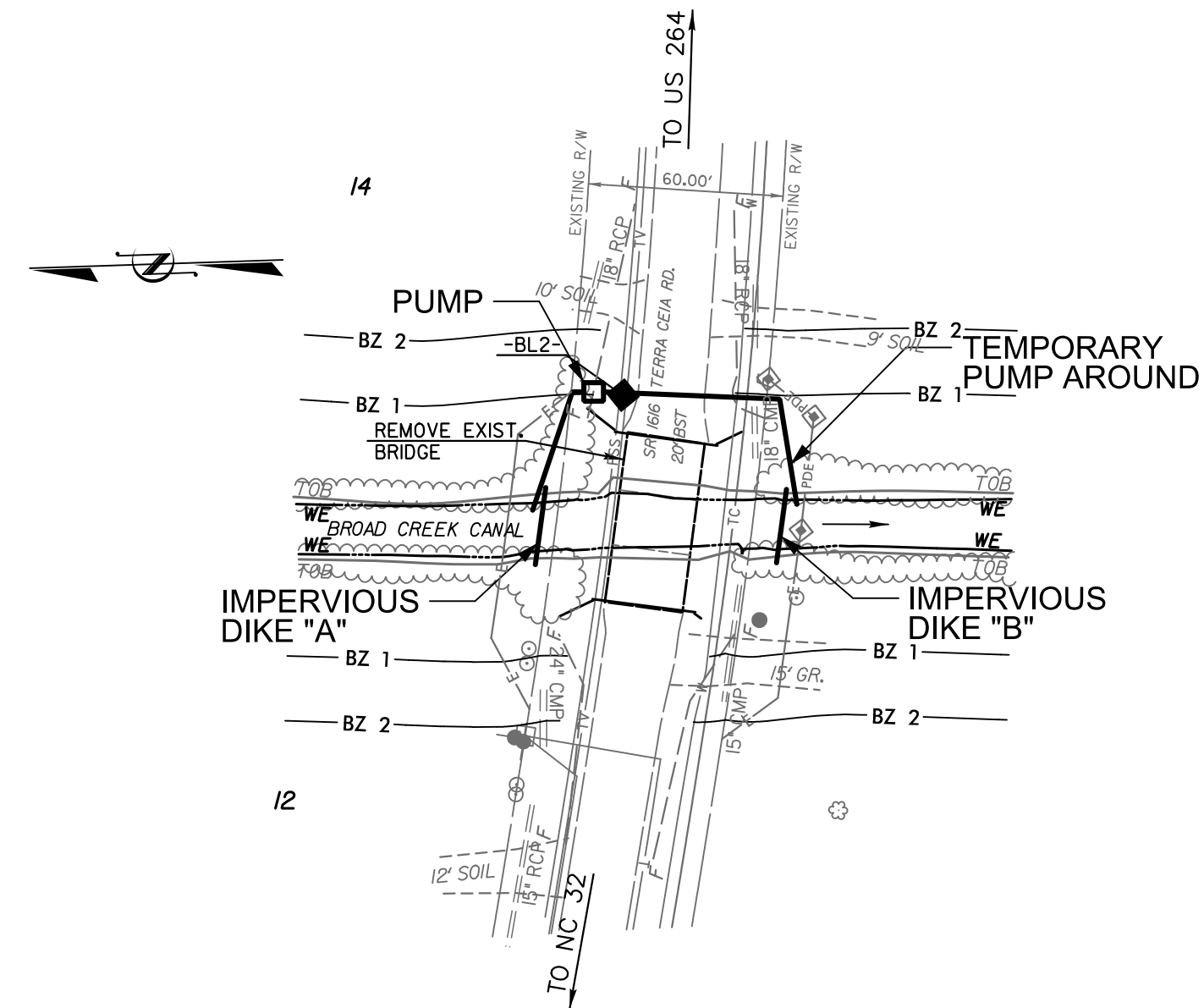

## PHASE I

1. INSTALL IMPERVIOUS DIKES "A" AND "B" AS SHOWN.
2. INSTALL PIPE AND PUMP. THEN PUMP BROAD CREEK CANAL AROUND CONSTRUCTION AREA.
3. DEWATER CONSTRUCTION AREA INTO SPECIAL STILLING BASIN(S).

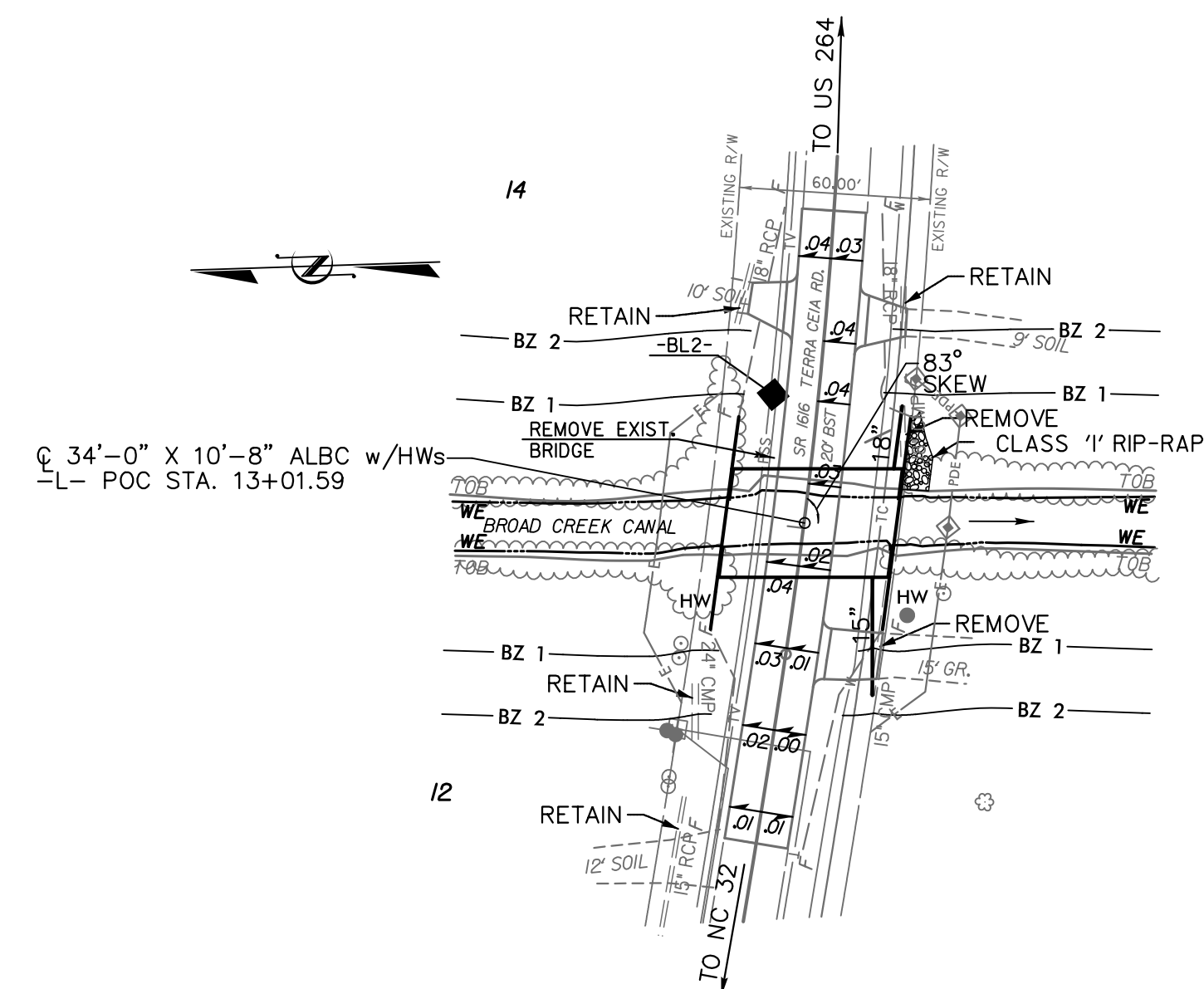

## PHASE II

1. REMOVE EXISTING STRUCTURE AND REMNANTS OF ANY PREVIOUS STRUCTURES IN THEIR ENTIRETY, UNLESS OTHERWISE NOTED.
2. INSTALL ALUMINUM BOX CULVERT & GRADE CHANNEL. LINE DOWNSTREAM CHANNEL BANKS WITH CLASS I RIP RAP AS SHOWN.
3. UPON COMPLETION OF RIP RAP PLACEMENT, REMOVE IMPERVIOUS DIKES, PUMP AND TEMP. PIPE.

5/14/99



**Q2**  
 PERMANENT WETLAND IMPACTS = 0.0 Ac / 0 SF  
 MECHANIZED CLEARING IN WETLANDS = 0.0 Ac / 0 SF  
 PERMANENT STREAM IMPACTS = 0 LF  
 TEMPORARY STREAM IMPACTS = 0 LF  
 BUFFER ZONE 1 IMPACTS = 755 SF  
 BUFFER ZONE 2 IMPACTS = 265 SF

**Q1**  
 PERMANENT WETLAND IMPACTS = 0.0 Ac / 0 SF  
 MECHANIZED CLEARING IN WETLANDS = 0.0 Ac / 0 SF  
 PERMANENT STREAM IMPACTS = 55 LF  
 TEMPORARY STREAM IMPACTS = 21 LF  
 BUFFER ZONE 1 IMPACTS = 660 SF  
 BUFFER ZONE 2 IMPACTS = 204 SF

**Q3**  
 PERMANENT WETLAND IMPACTS = 0.0 Ac / 0 SF  
 MECHANIZED CLEARING IN WETLANDS = 0.0 Ac / 0 SF  
 PERMANENT STREAM IMPACTS = 0 LF  
 TEMPORARY STREAM IMPACTS = 0 LF  
 BUFFER ZONE 1 IMPACTS = 651 SF  
 BUFFER ZONE 2 IMPACTS = 249 SF

**Q4**  
 PERMANENT WETLAND IMPACTS = 0.0 Ac / 0 SF  
 MECHANIZED CLEARING IN WETLANDS = 0.0 Ac / 0 SF  
 PERMANENT STREAM IMPACTS = 0 LF  
 TEMPORARY STREAM IMPACTS = 16 LF  
 BUFFER ZONE 1 IMPACTS = 738 SF  
 BUFFER ZONE 2 IMPACTS = 188 SF

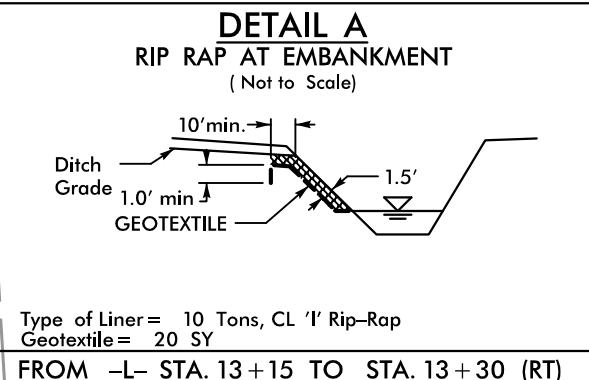
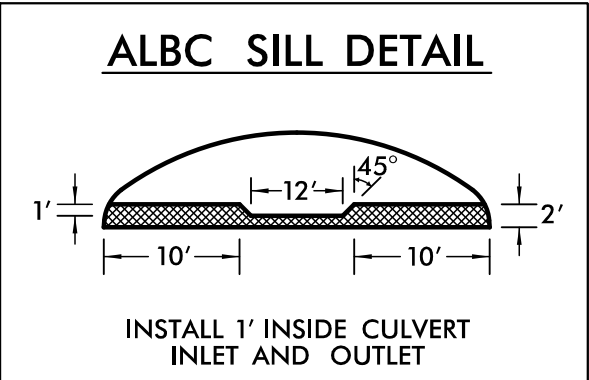

**IMPACT SUMMARY:**  
 404 WETLAND IMPACTS = 0.0 AC  
 STREAM IMPACTS = 92 FT.  
 BUFFER ZONE 1 IMPACT = 2804 SQ. FT.  
 BUFFER ZONE 2 IMPACT = 906 SQ. FT.

**LEGEND**

	ALLOWABLE IMPACTS ZONE 1
	ALLOWABLE IMPACTS ZONE 2
	DENOTES IMPACTS IN SURFACE WATER
	DENOTES TEMPORARY IMPACTS IN SURFACE WATER

**NCDOT**  
 17BP.2.R.53 BEAUFORT COUNTY  
 REPLACE BRIDGE NO. 0161  
 SR 1616 (TERRA CEIA RD.)  
 OVER BROAD CREEK CANAL  
 BETWEEN NC HWY 32  
 AND US HWY 264  
 SCALE: 1" = 50'  
 OCTOBER 28, 2013  
 FOR PERMITTING ONLY:  
 NOT FOR CONSTRUCTION

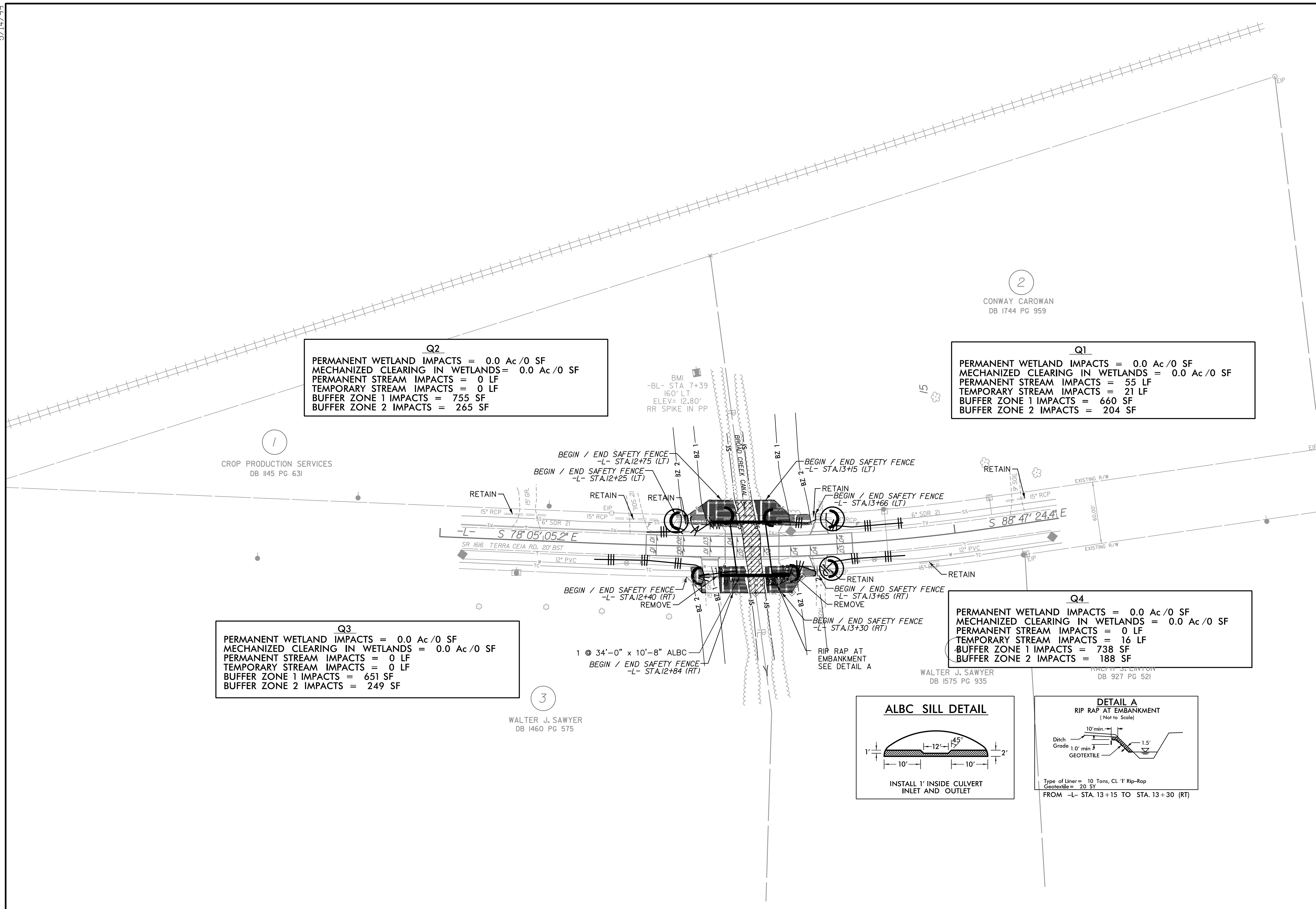



Note: Approximate quantities only. Unclassified Excavation, Borrow Excavation, Shoulder Borrow, Fine Grading, Clearing and Grubbing, Breaking of Existing Pavement, and Removal of Existing Pavement will be paid for at the contract lump sum price for "Grading."

STATE OF NORTH CAROLINA  
DIVISION OF HIGHWAYS

**CROSS-SECTION SUMMARY**  
*IN CUBIC YARDS*

NOTE: EMBANKMENT COLUMN DOES NOT INCLUDE BACKFILL FOR UNDERCUT

STATION	UNCLASSIFIED EXCAVATION	EMBANK.	UNDERCUT
-L- STA. 11 + 50.00	0	0	0
-L- STA. 12 + 00.00	0	0	0
-L- STA. 12 + 50.00	34	0	0
-L- STA. 13 + 00.00	12	139	0
-L- STA. 13 + 50.00	10	177	0
-L- STA. 14 + 00.00	32	2	0
-L- STA. 14 + 50.00	0	0	0

02/03/98

PROJ. REFERENCE NO.	SHEET NO.	TOTAL SHEETS
17BP.2.R.53	X-2	3

75 70 65 60 55 50 45 40 35 30 25 20 15 10 5 0 5 10 15 20 25 30 35 40 45 50

55 60 65 70 75

C

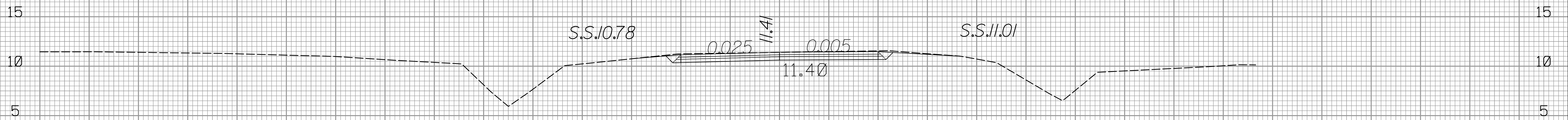

12+50.00

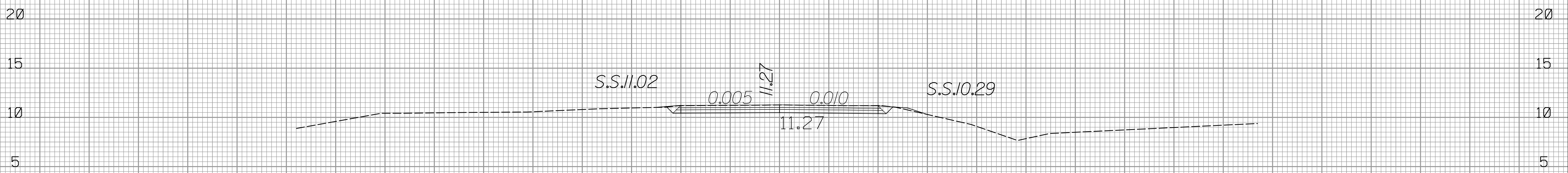

12+00.00

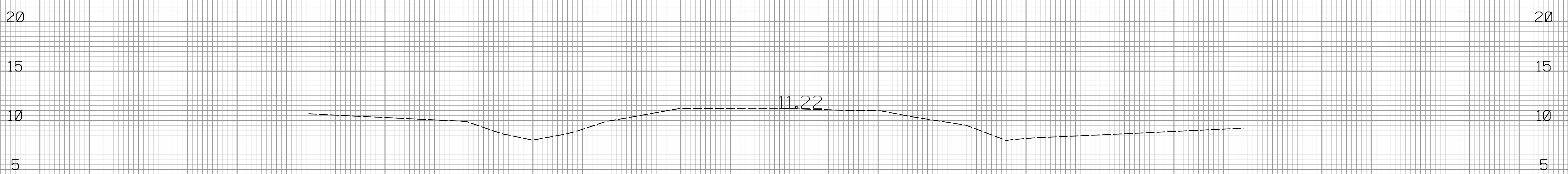

11+50.00

75 70 65 60 55 50 45 40 35 30 25 20 15 10 5 0 5 10 15 20 25 30 35 40 45 50

55 60 65 70 75

3:09:55 PM \\SC060161.rdl.sp1.dgn

02/03/98

PROJ. REFERENCE NO.	SHEET NO.	TOTAL SHEETS
17BP.2.R.53	X-3	3

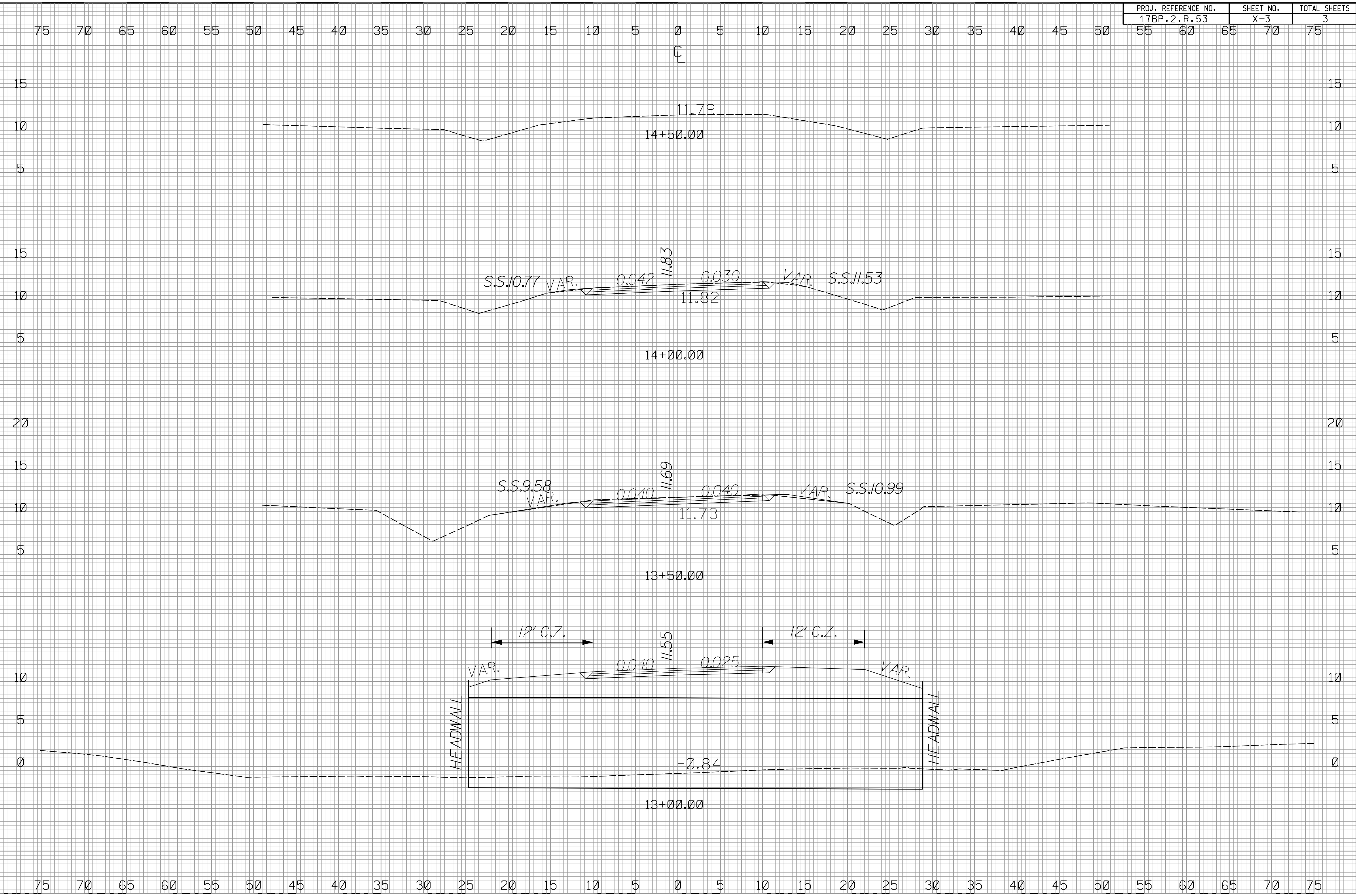

3:05:57 PM \\SC060161.rdu\sp1.dgn

09/08/99

TIP PROJECT: 17BP.2.R.53

STATE OF NORTH CAROLINA  
DIVISION OF HIGHWAYS

T.I.P. NO.	SHEET NO.
17BP.2.R.53	UO-1

**HNTB** HNTB NORTH CAROLINA, P.C.  
343 E. Six Forks Road, Suite 200  
Raleigh, North Carolina 27609  
NC License No: C-1554

DATE: OCTOBER 11, 2013

**UTILITIES BY OTHERS PLANS  
BEAUFORT COUNTY**

LOCATION: BRIDGE NO. 161 ON SR 1616 (TERRA CEIA RD.)  
OVER BROAD CREEK CANAL  
TYPE OF WORK: UTILITY BY OTHERS RELOCATION

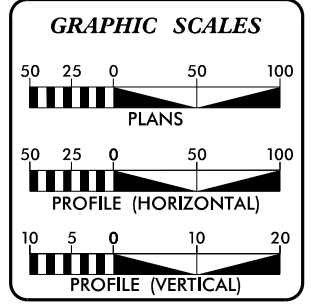
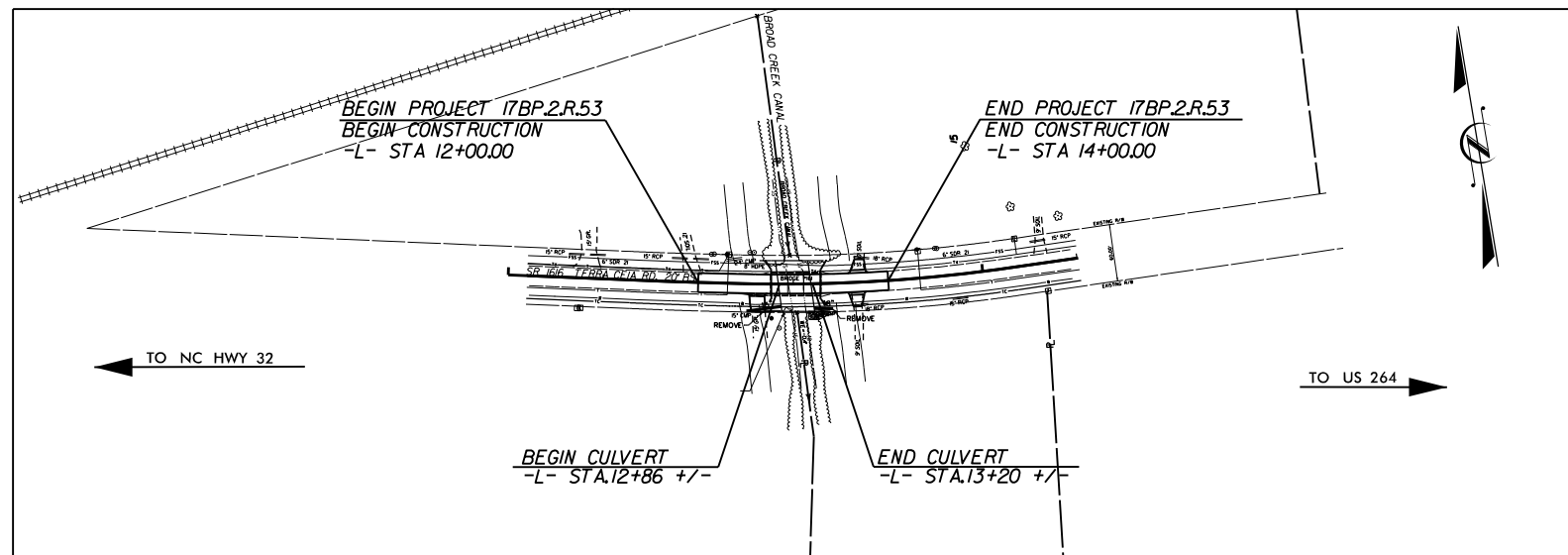
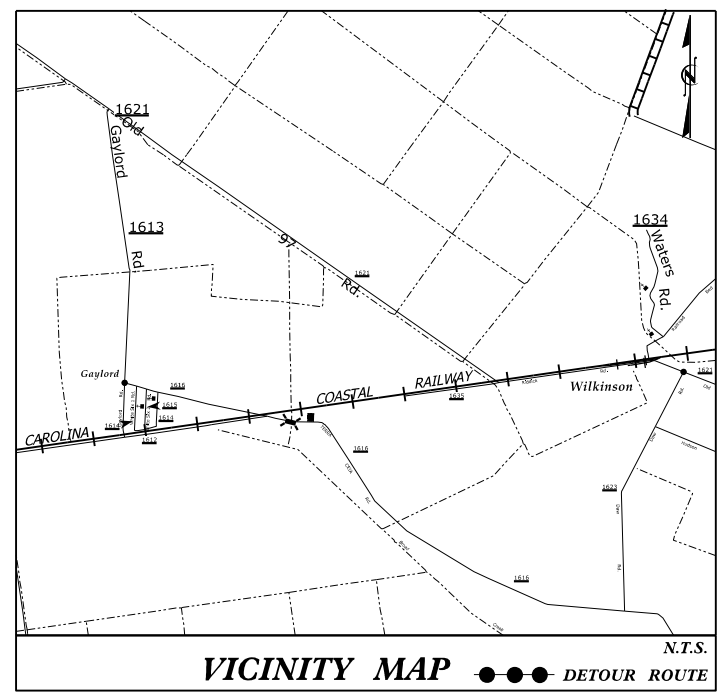

INDEX OF SHEETS

SHEET NO.	DESCRIPTION
UO-1	TITLE SHEET
UO-2	PLAN SHEET

- UTILITY OWNERS ON PROJECT
- (1) TIDELAND ELECTRIC - POWER
  - (2) CITY OF WASHINGTON - POWER
  - (3) TRI-COUNTY TELEPHONE - TELEPHONE
  - (4) CENTURYLINK - TELEPHONE
  - (5) TOWN OF BELHAVEN - FORCE MAIN

UTILITY DESIGN BY:

**MA Engineering**  
CONSULTANTS, INC.  
598 East Chatham Street Suite 137 Cary, NC 27511  
Phone: 919 297 0220 Fax: 919 297 0221

NCDOT PROJECT ENGINEER:  
MARIA ROGERSON, P.E.

PREPARED FOR:  
NORTH CAROLINA  
DEPARTMENT OF TRANSPORTATION  
DIVISION BRIDGE PROGRAM

\$\$\$\$\$SYTIME\$\$\$\$\$  
\$\$\$\$\$DGN\$\$\$\$\$  
\$\$\$\$\$USERNAME\$\$\$\$\$



