

09/08/99

K:\DUR\_Utillities\_Roadway\_Utillities Projects\01036510 - BR0074 Hwy 70 Bridges\Roadway\BR0074A\_rdy\_1st.dgn

12/13/2022

**TIP PROJECT: BR-0074A**

**CONTRACT:**

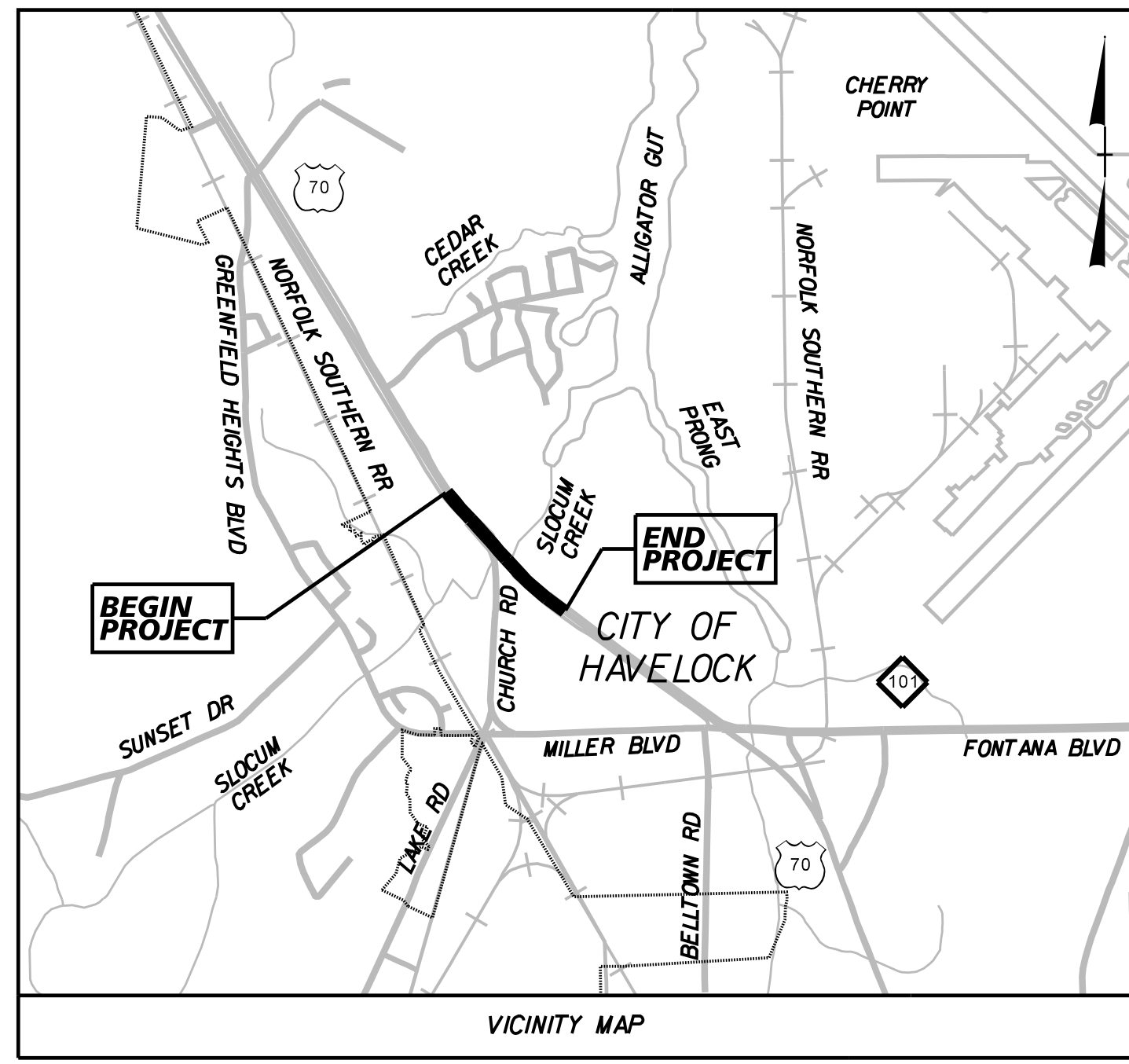

— HAVELOCK CITY LIMIT

STATE OF NORTH CAROLINA  
DIVISION OF HIGHWAYS  
**CRAVEN COUNTY**

STATE	STATE PROJECT REFERENCE NO.	SHEET NO.	TOTAL SHEETS
N.C.	BR-0074A	1	
STATE PROJ. NO.	F.A. PROJ. NO.	DESCRIPTION	
67074.1.1		P.E.	
67074.2.1		RIGHT-OF-WAY	
67074.2.1		UTILITIES	

**LOCATION: BRIDGES 240091 AND 240092 ON US 70 OVER S. PRONG SLOCUM CREEK**  
**TYPE OF WORK: UTILITY RELOCATION**

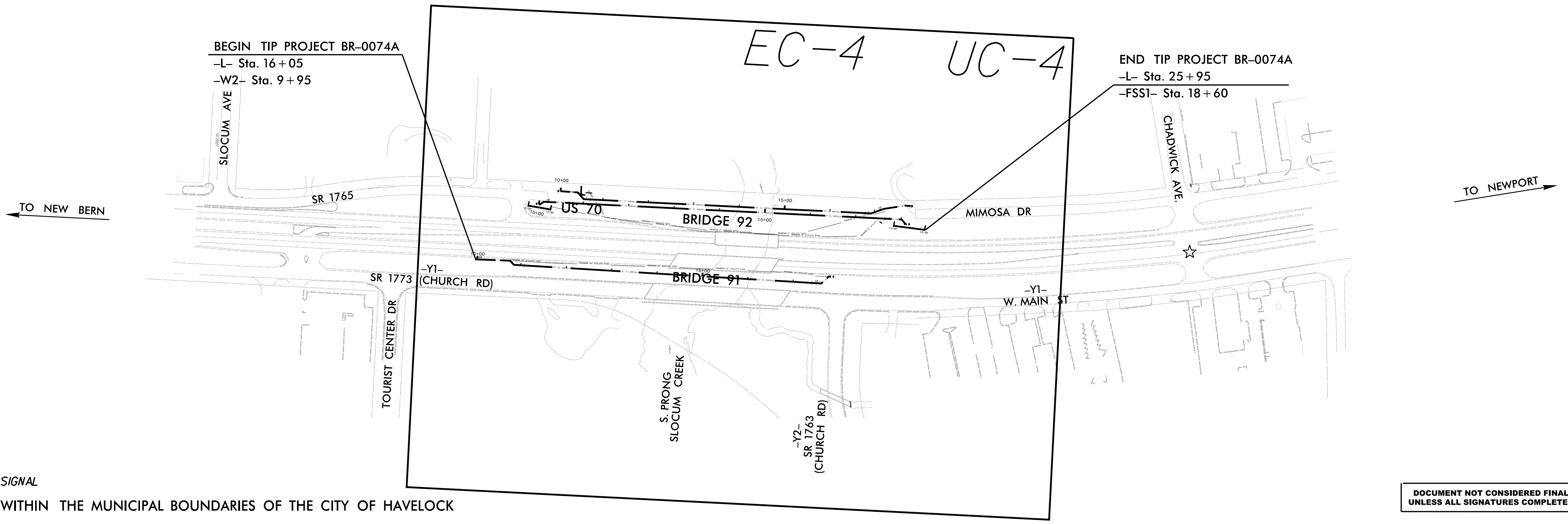
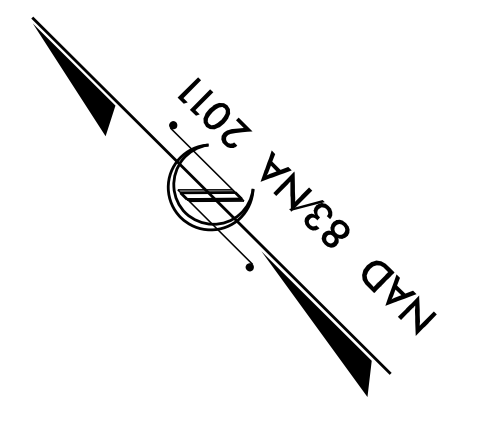

☆ EXIST TRAFFIC SIGNAL

THIS PROJECT IS WITHIN THE MUNICIPAL BOUNDARIES OF THE CITY OF HAVELOCK

DOCUMENT NOT CONSIDERED FINAL  
UNLESS ALL SIGNATURES COMPLETED

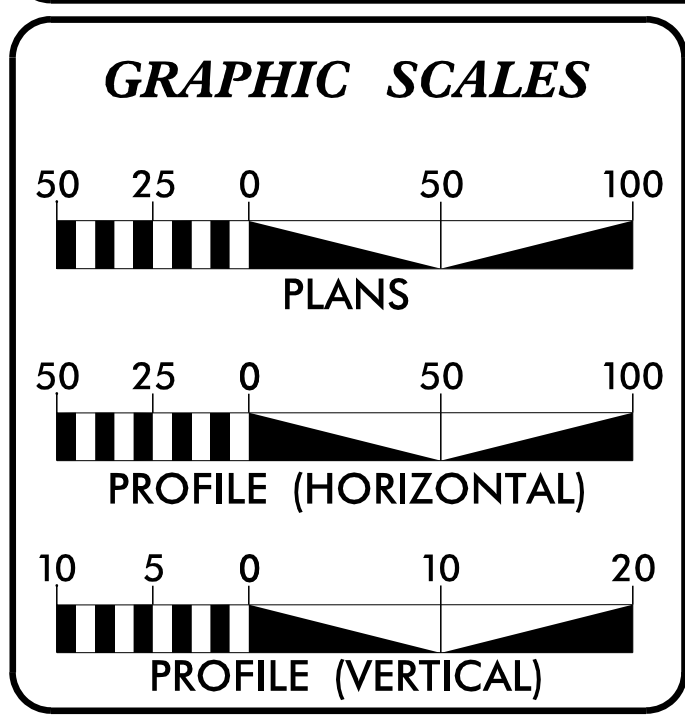

**DESIGN DATA**

N/A

**PROJECT LENGTH**

N/A

PLANS PREPARED FOR THE NCDOT BY:

2018 STANDARD SPECIFICATIONS

RIGHT OF WAY DATE: N/A

LETTING DATE: FEBRUARY 22, 2023

**Kimley»Horn**

JEFFREY W. MOORE, P.E. PROJECT ENGINEER

NATE HARVEY, P.E. PROJECT DESIGN ENGINEER

CLAUDIA W. LEE, P.E. PROJECT MANAGER NCDOT PROJECT MANAGEMENT UNIT

**HYDRAULICS ENGINEER**

N/A

SIGNATURE: \_\_\_\_\_ P.E.

**ROADWAY DESIGN ENGINEER**

N/A

SIGNATURE: \_\_\_\_\_ P.E.

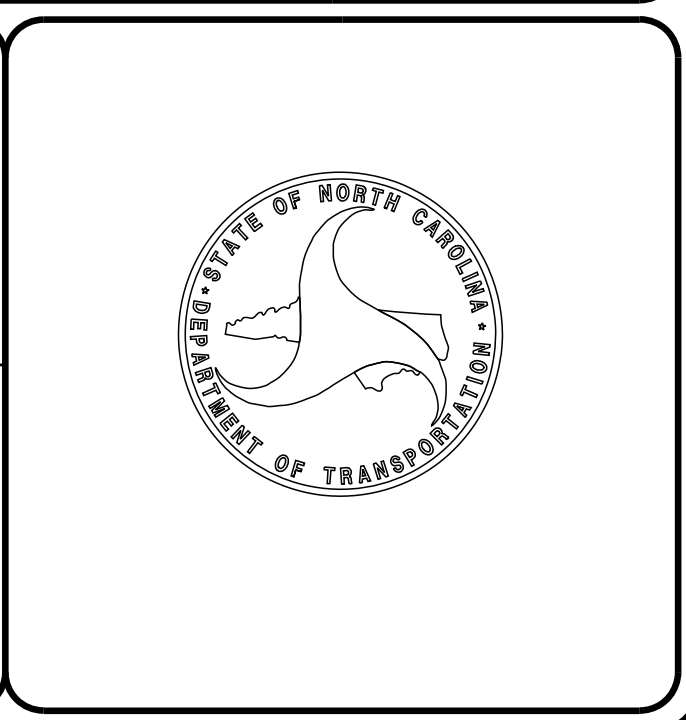

**INDEX OF SHEETS**

<u>SHEET NUMBER</u>	<u>DESCRIPTION</u>
I	TITLE SHEET
IA	INDEX OF SHEETS AND GENERAL NOTES
IB	CONVENTIONAL SYMBOLS
EC-I THRU EC-4	EROSION CONTROL SHEETS
UC-I THRU UC-7	UTILITY CONSTRUCTION PLANS
UO-I THRU UO-5	UTILITIES BY OTHERS

**GENERAL NOTES**

GENERAL NOTES:

2018 SPECIFICATIONS  
EFFECTIVE: 01-16-2018  
REVISED:

**PROJECT NOTES**

- I. PROJECT BR-0074A INCLUDES UTILITY RELOCATIONS AND ASSOCIATED EROSION CONTROL AND TRAFFIC CONTROL. THE UTILITY RELOCATIONS ARE NECESSARY FOR THE PERFORMANCE OF BRIDGE REPLACEMENTS TO BE CONSTRUCTED SEPARATELY AS PART OF PROJECT BR-0074.

# STATE OF NORTH CAROLINA, DIVISION OF HIGHWAYS CONVENTIONAL PLAN SHEET SYMBOLS

Note: Not to Scale

### BOUNDARIES AND PROPERTY:

State Line	-----
County Line	-----
Township Line	-----
City Line	-----
Reservation Line	-----
Property Line	-----
Existing Iron Pin (EIP)	○
Computed Property Corner	X
Existing Concrete Monument (ECM)	□
Parcel/Sequence Number	(23)
Existing Fence Line	-x-x-x-
Proposed Woven Wire Fence	○
Proposed Chain Link Fence	□
Proposed Barbed Wire Fence	◇
Existing Wetland Boundary	-----WLB-----
Proposed Wetland Boundary	-----WLB-----
Existing Endangered Animal Boundary	-----EAB-----
Existing Endangered Plant Boundary	-----EPB-----
Existing Historic Property Boundary	-----HPB-----
Known Contamination Area: Soil	-----S-----
Potential Contamination Area: Soil	-----S-----
Known Contamination Area: Water	-----W-----
Potential Contamination Area: Water	-----W-----
Contaminated Site: Known or Potential	☠ ☢

### BUILDINGS AND OTHER CULTURE:

Gas Pump Vent or U/G Tank Cap	○
Sign	○
Well	○
Small Mine	⊗
Foundation	□
Area Outline	□
Cemetery	⊕
Building	□
School	□
Church	□
Dam	-----

### HYDROLOGY:

Stream or Body of Water	-----
Hydro, Pool or Reservoir	-----
Jurisdictional Stream	-----JS-----
Buffer Zone 1	-----BZ 1-----
Buffer Zone 2	-----BZ 2-----
Flow Arrow	←
Disappearing Stream	-----
Spring	○
Wetland	-----
Proposed Lateral, Tail, Head Ditch	-----
False Sump	-----

### RAILROADS:

Standard Gauge	-----
RR Signal Milepost	○
Switch	□
RR Abandoned	-----
RR Dismantled	-----

### RIGHT OF WAY & PROJECT CONTROL:

Primary Horiz Control Point	○
Primary Horiz and Vert Control Point	●
Secondary Horiz and Vert Control Point	◆
Vertical Benchmark	⊕
Existing Right of Way Monument	△
Proposed Right of Way Monument (Rebar and Cap)	▲
Proposed Right of Way Monument (Concrete)	▲
Existing Permanent Easement Monument	◇
Proposed Permanent Easement Monument (Rebar and Cap)	◇
Existing C/A Monument	△
Proposed C/A Monument (Rebar and Cap)	▲
Proposed C/A Monument (Concrete)	▲
Existing Right of Way Line	-----
Proposed Right of Way Line	-----
Existing Control of Access Line	-----
Proposed Control of Access Line	-----
Proposed ROW and CA Line	-----
Existing Easement Line	-----E-----
Proposed Temporary Construction Easement	-----E-----
Proposed Temporary Drainage Easement	-----TDE-----
Proposed Permanent Drainage Easement	-----PDE-----
Proposed Permanent Drainage/Utility Easement	-----DUE-----
Proposed Permanent Utility Easement	-----PUE-----
Proposed Temporary Utility Easement	-----TUE-----
Proposed Aerial Utility Easement	-----AUE-----

### ROADS AND RELATED FEATURES:

Existing Edge of Pavement	-----
Existing Curb	-----
Proposed Slope Stakes Cut	-----C-----
Proposed Slope Stakes Fill	-----F-----
Proposed Curb Ramp	-----CR-----
Existing Metal Guardrail	-----
Proposed Guardrail	-----
Existing Cable Guiderail	-----
Proposed Cable Guiderail	-----
Equality Symbol	⊕
Pavement Removal	-----
VEGETATION:	
Single Tree	○
Single Shrub	○
Hedge	-----

Woods Line	-----
Orchard	-----
Vineyard	-----

### EXISTING STRUCTURES:

MAJOR:	
Bridge, Tunnel or Box Culvert	-----
Bridge Wing Wall, Head Wall and End Wall	-----
MINOR:	
Head and End Wall	-----
Pipe Culvert	-----
Footbridge	-----
Drainage Box: Catch Basin, DI or JB	-----
Paved Ditch Gutter	-----
Storm Sewer Manhole	-----
Storm Sewer	-----

### UTILITIES:

\* SUE - Subsurface Utility Engineering  
LOS - Level of Service - A,B,C or D (Accuracy)

POWER:	
Existing Power Pole	●
Proposed Power Pole	○
Existing Joint Use Pole	●
Proposed Joint Use Pole	○
Power Manhole	⊕
Power Line Tower	⊗
Power Transformer	⊗
U/G Power Cable Hand Hole	⊕
H-Frame Pole	●
U/G Power Line Test Hole (SUE - LOS A)*	⊕
U/G Power Line (SUE - LOS B)*	-----P-----
U/G Power Line (SUE - LOS C)*	-----P-----
U/G Power Line (SUE - LOS D)*	-----P-----

### TELEPHONE:

Existing Telephone Pole	●
Proposed Telephone Pole	○
Telephone Manhole	⊕
Telephone Pedestal	⊕
Telephone Cell Tower	⊗
U/G Telephone Cable Hand Hole	⊕
U/G Telephone Test Hole (SUE - LOS A)*	⊕
U/G Telephone Cable (SUE - LOS B)*	-----T-----
U/G Telephone Cable (SUE - LOS C)*	-----T-----
U/G Telephone Cable (SUE - LOS D)*	-----T-----
U/G Telephone Conduit (SUE - LOS B)*	-----TC-----
U/G Telephone Conduit (SUE - LOS C)*	-----TC-----
U/G Telephone Conduit (SUE - LOS D)*	-----TC-----
U/G Fiber Optics Cable (SUE - LOS B)*	-----T FO-----
U/G Fiber Optics Cable (SUE - LOS C)*	-----T FO-----
U/G Fiber Optics Cable (SUE - LOS D)*	-----T FO-----

WATER:	
Water Manhole	⊕
Water Meter	○
Water Valve	⊗
Water Hydrant	⊕
U/G Water Line Test Hole (SUE - LOS A)*	⊕
U/G Water Line (SUE - LOS B)*	-----
U/G Water Line (SUE - LOS C)*	-----
U/G Water Line (SUE - LOS D)*	-----
Above Ground Water Line	-----A/G Water-----
TV:	
TV Pedestal	⊕
TV Tower	⊗
U/G TV Cable Hand Hole	⊕
U/G TV Test Hole (SUE - LOS A)*	⊕
U/G TV Cable (SUE - LOS B)*	-----TV-----
U/G TV Cable (SUE - LOS C)*	-----TV-----
U/G TV Cable (SUE - LOS D)*	-----TV-----
U/G Fiber Optic Cable (SUE - LOS B)*	-----TV FO-----
U/G Fiber Optic Cable (SUE - LOS C)*	-----TV FO-----
U/G Fiber Optic Cable (SUE - LOS D)*	-----TV FO-----
GAS:	
Gas Valve	◇
Gas Meter	◇
U/G Gas Line Test Hole (SUE - LOS A)*	⊕
U/G Gas Line (SUE - LOS B)*	-----G-----
U/G Gas Line (SUE - LOS C)*	-----G-----
U/G Gas Line (SUE - LOS D)*	-----G-----
Above Ground Gas Line	-----A/G Gas-----
SANITARY SEWER:	
Sanitary Sewer Manhole	⊕
Sanitary Sewer Cleanout	⊕
U/G Sanitary Sewer Line	-----SS-----
Above Ground Sanitary Sewer	-----A/G Sanitary Sewer-----
SS Force Main Line Test Hole (SUE - LOS A)*	⊕
SS Force Main Line (SUE - LOS B)*	-----FSS-----
SS Force Main Line (SUE - LOS C)*	-----FSS-----
SS Force Main Line (SUE - LOS D)*	-----FSS-----
MISCELLANEOUS:	
Utility Pole	●
Utility Pole with Base	□
Utility Located Object	○
Utility Traffic Signal Box	⊕
Utility Unknown U/G Line (SUE - LOS B)*	-----TUL-----
U/G Tank; Water, Gas, Oil	-----
Underground Storage Tank, Approx. Loc.	⊕
A/G Tank; Water, Gas, Oil	-----
Geoenvironmental Boring	⊕
Abandoned According to Utility Records	AATUR
End of Information	E.O.I.





# SILT FENCE COIR FIBER WATTLE BREAK DETAIL

PROJECT REFERENCE NO. BR-0074A	SHEET NO. EC-2
RW SHEET NO.	
ROADWAY DESIGN ENGINEER	HYDRAULICS ENGINEER

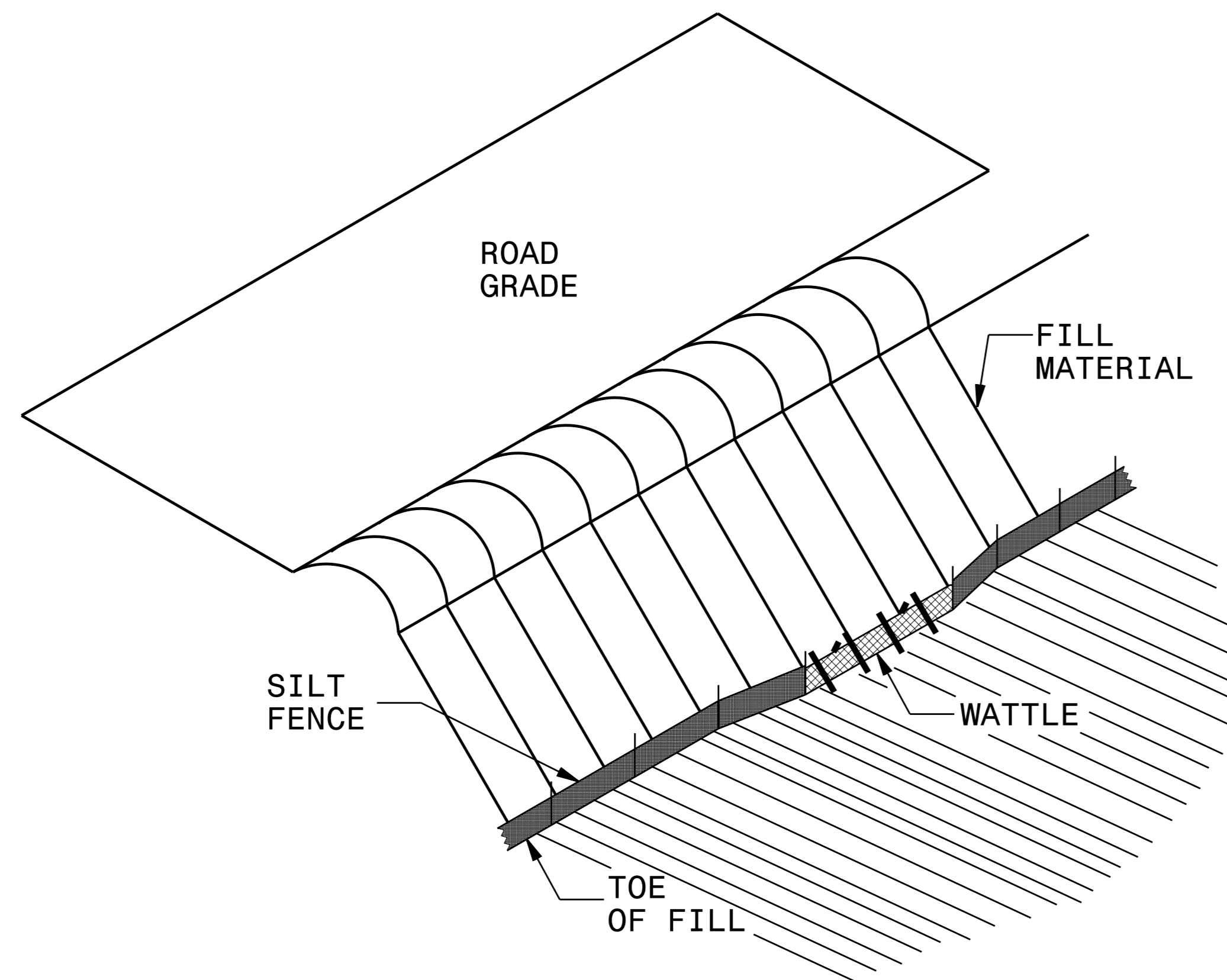

**ISOMETRIC VIEW**

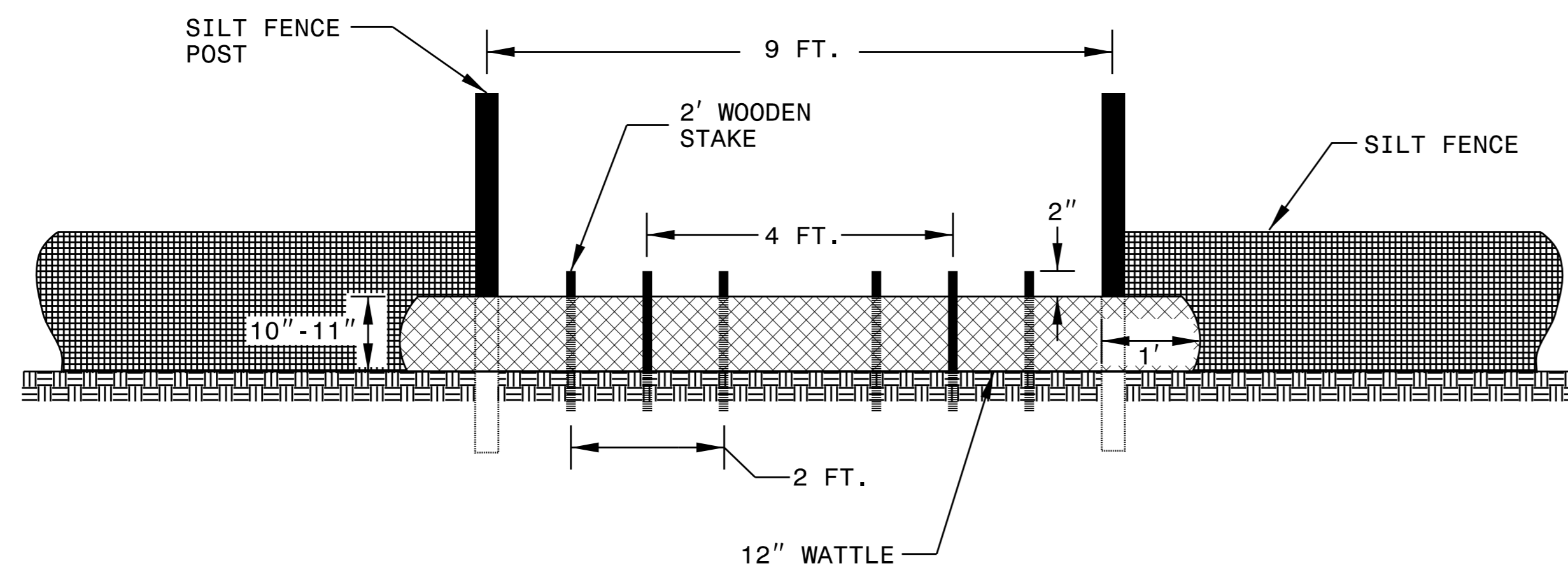

**VIEW FROM SLOPE**

**NOTES:**

USE MINIMUM 12 IN. DIAMETER COIR FIBER (COCONUT FIBER) WATTLE AND LENGTH OF 10 FT.

EXCAVATE A 1 TO 2 INCH TRENCH FOR WATTLE TO BE PLACED.

DO NOT PLACE WATTLE ON TOE OF SLOPE.

USE 2 FT. WOODEN STAKES WITH A 2 IN. BY 2 IN. NOMINAL CROSS SECTION.

INSTALL A MINIMUM OF 2 UPSLOPE STAKES AND 4 DOWNSLOPE STAKES AT AN ANGLE TO WEDGE WATTLE TO GROUND.

PROVIDE STAPLES MADE OF 0.125 IN. DIAMETER STEEL WIRE FORMED INTO A U SHAPE NOT LESS THAN 12" IN LENGTH.

INSTALL STAPLES APPROXIMATELY EVERY 1 LINEAR FOOT ON BOTH SIDES OF WATTLE AND AT EACH END TO SECURE IT TO THE SOIL.

WATTLE INSTALLATION CAN BE ON OUTSIDE OF THE SILT FENCE AS DIRECTED.

INSTALL TEMPORARY SILT FENCE IN ACCORDANCE WITH SECTION 1605 OF THE STANDARD SPECIFICATIONS.

**INSET A**

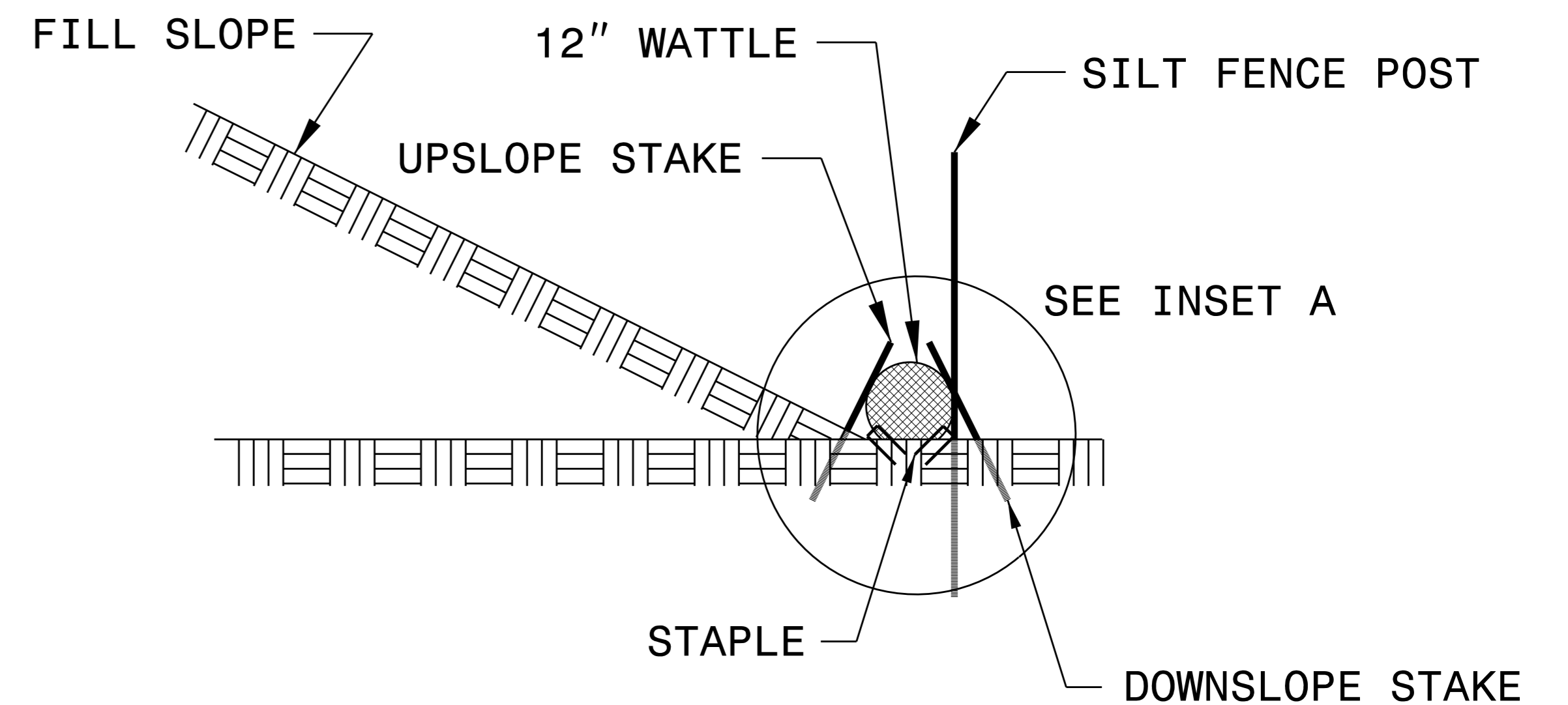
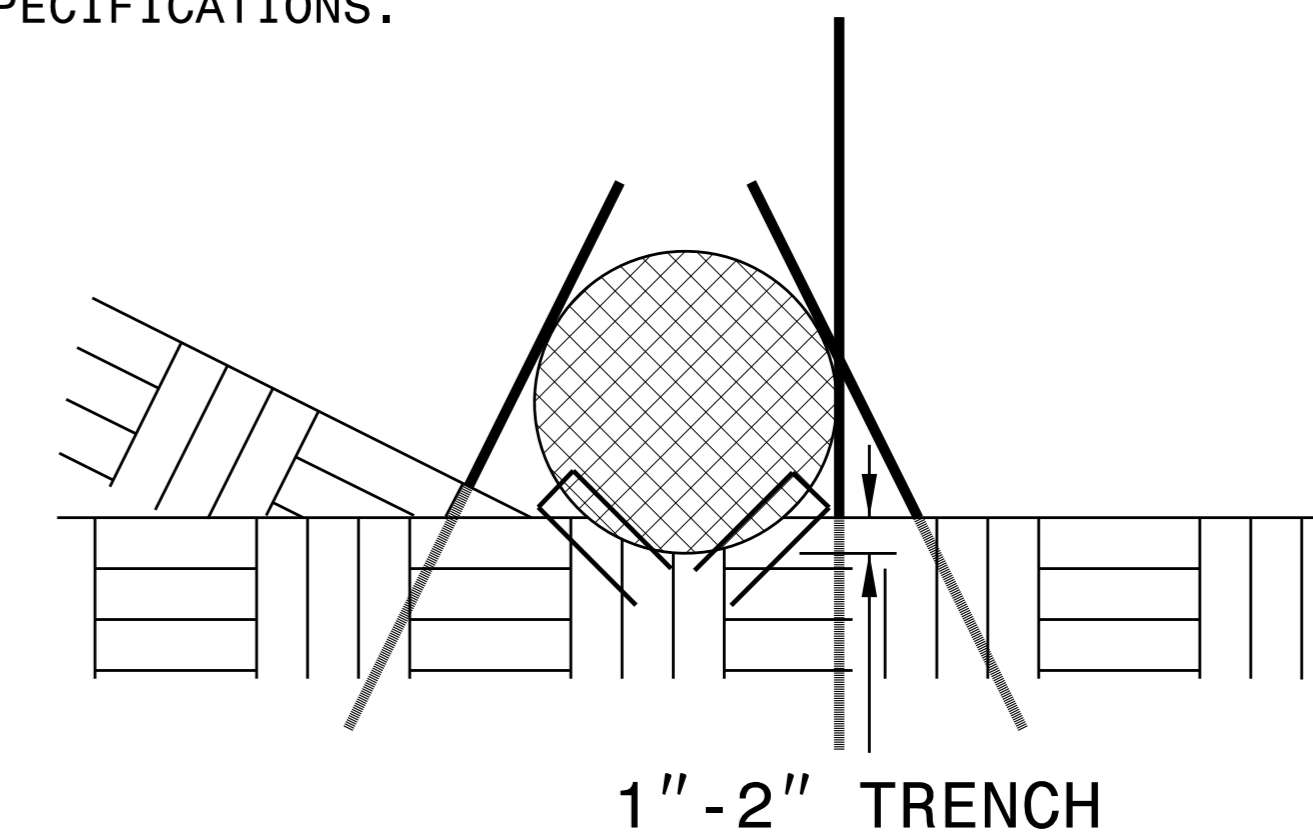

**SIDE VIEW**

DIVISION OF HIGHWAYS  
STATE OF NORTH CAROLINA

---



---

PROJECT REFERENCE NO. <i>BR-0074A</i>	SHEET NO. <i>EC-3</i>
ROADWAY DESIGN ENGINEER	HYDRAULICS ENGINEER

# ***SOIL STABILIZATION TIMEFRAMES***

<i>SITE DESCRIPTION</i>	<i>STABILIZATION TIME</i>	<i>TIMEFRAME EXCEPTIONS</i>
PERIMETER DIKES, SWALES, DITCHES AND SLOPES	7 DAYS	NONE
HIGH QUALITY WATER (HQW) ZONES	7 DAYS	NONE
SLOPES STEEPER THAN 3:1	7 DAYS	IF SLOPES ARE 10' OR LESS IN LENGTH AND ARE NOT STEEPER THAN 2:1, 14 DAYS ARE ALLOWED.
SLOPES 3:1 OR FLATTER	14 DAYS	7 DAYS FOR SLOPES GREATER THAN 50' IN LENGTH.
ALL OTHER AREAS WITH SLOPES FLATTER THAN 4:1	14 DAYS	NONE, EXCEPT FOR PERIMETERS AND HQW ZONES.

5/14/99

NOTE:  
THE OUTSIDE BUFFER, WETLAND, OR WATER BOUNDARY SHALL BE CLEARLY MARKED BY HIGHLY VISIBLE FENCING (ORANGE SAFETY FENCE).

NAD 83/NA 2011

EROSION CONTROL FOR  
UTILITY CONSTRUCTION SHEET UC-4

**Kimley»Horn**

421 FAYETTEVILLE STREET, SUITE 600  
RALEIGH, NC 27601

PROJECT REFERENCE NO. BR-0074A	SHEET NO. EC-4
ROADWAY DESIGN ENGINEER	HYDRAULICS ENGINEER
RIGHT-OF-WAY REV.	
CONST. REV.	

REVISIONS

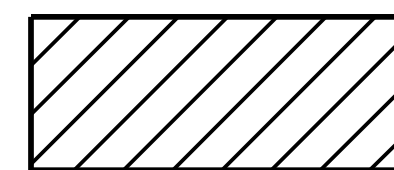
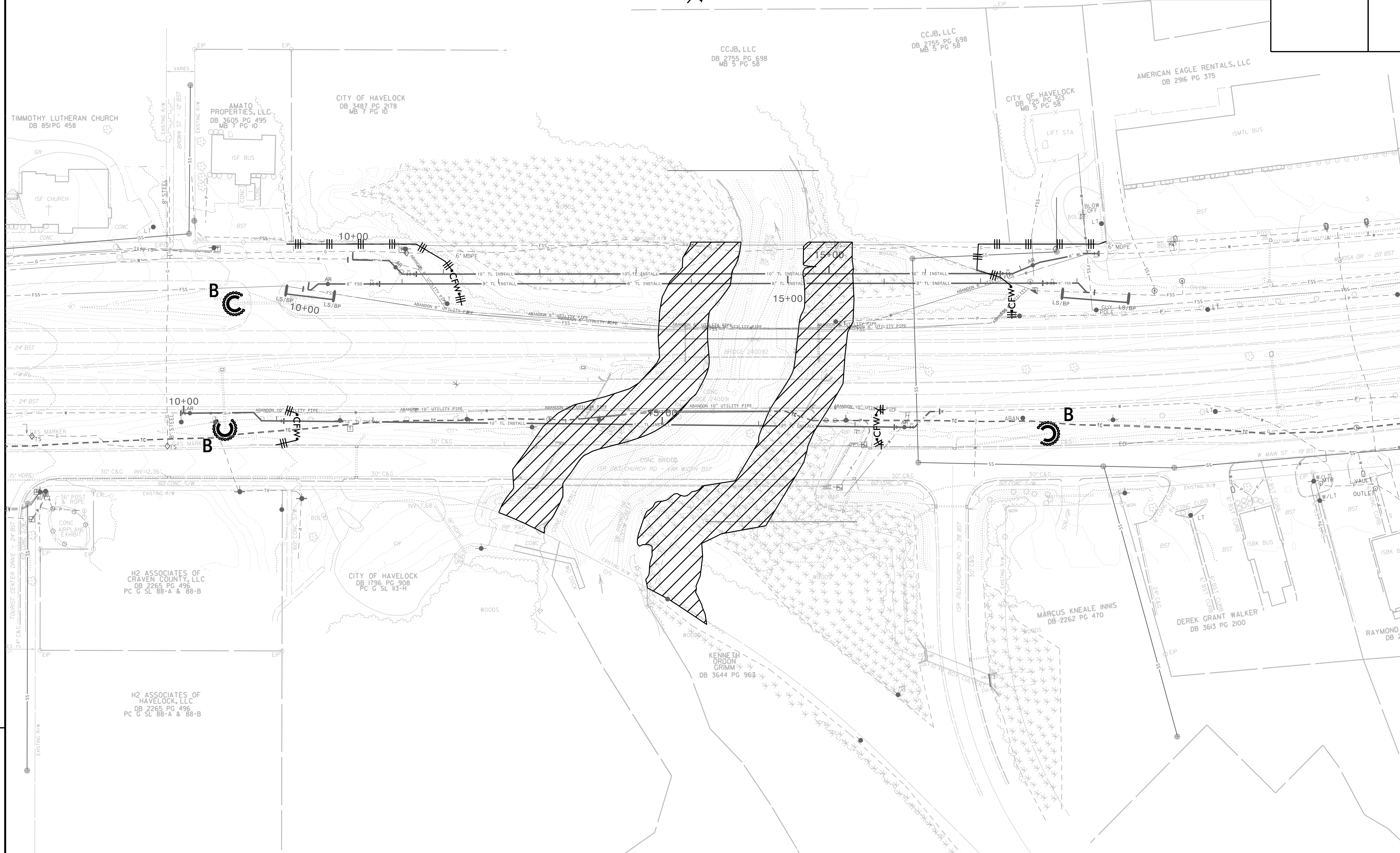

ENVIRONMENTALLY SENSITIVE AREA  
(DO NOT ENTER)  
SHOWN FOR REFERENCE ONLY  
SEE PROJECT SPECIAL PROVISIONS



TIP PROJECT: BR-0074A

T.I.P. NO.	SHEET NO.
BR-0074A	UC-1

STATE OF NORTH CAROLINA  
DIVISION OF HIGHWAYS

**UTILITY CONSTRUCTION PLANS**  
**CRAVEN COUNTY**

**LOCATION: BRIDGES 240091 AND 240092 ON US 70 OVER S. PRONG SLOCUM CREEK**

**TYPE OF WORK: RELOCATION OF WATER AND SANITARY FORCE MAIN**

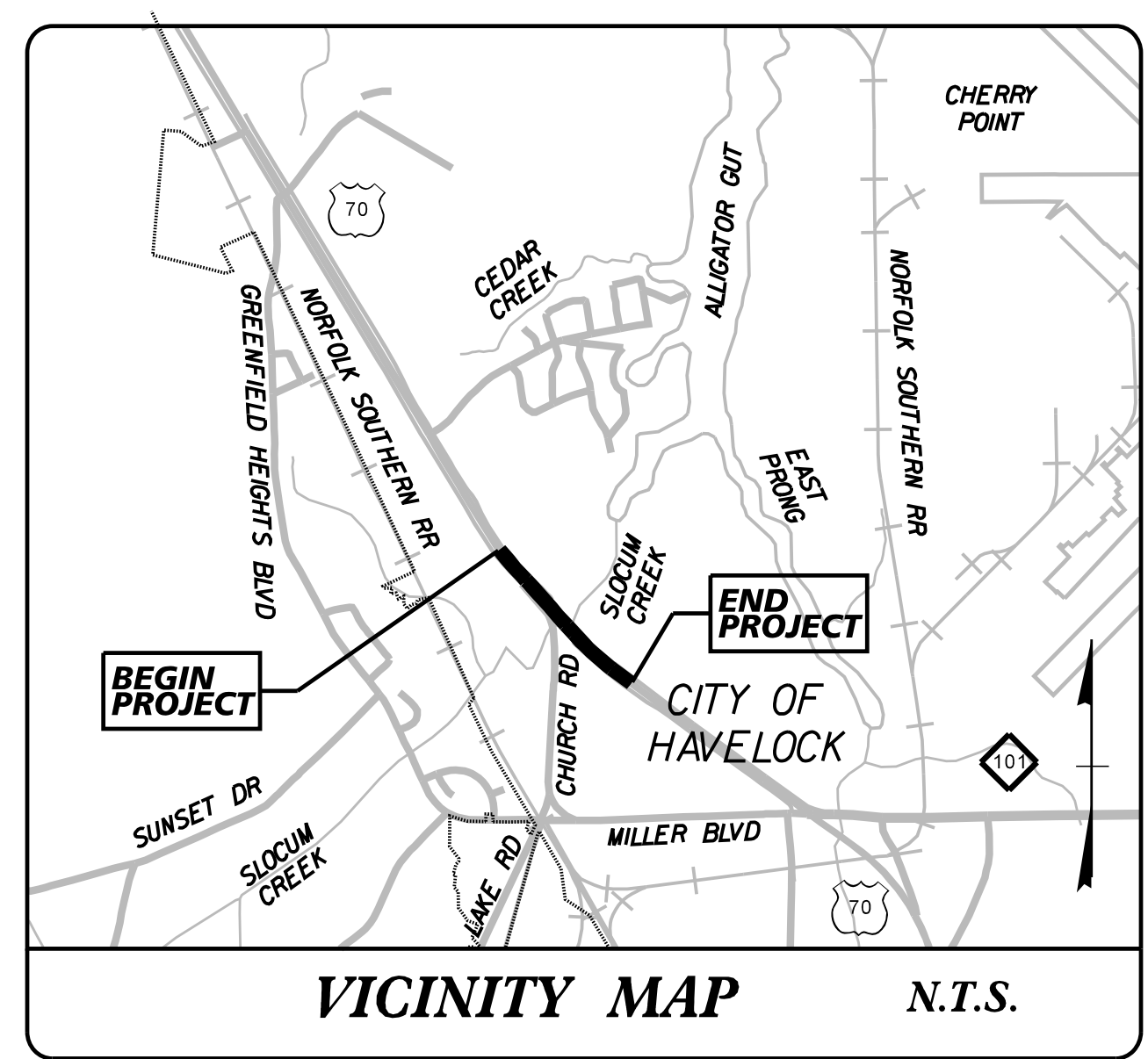

VICINITY MAP N.T.S.

— HAVELOCK CITY LIMIT

UC PLANS

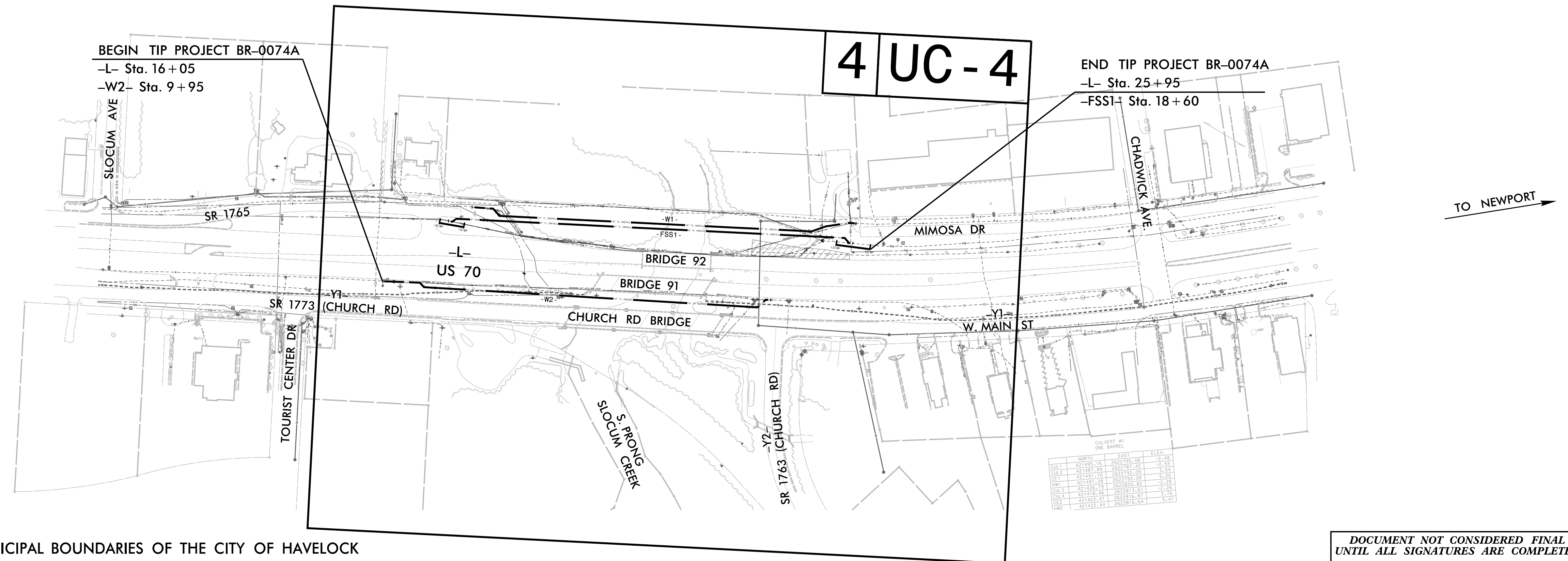
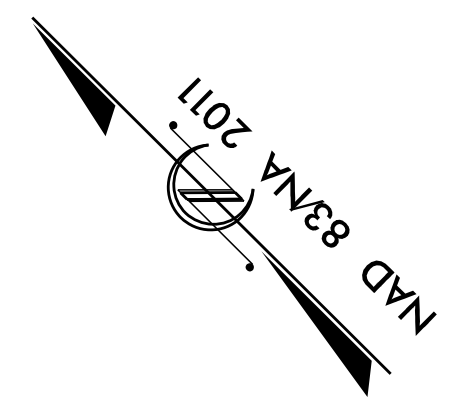

THIS PROJECT IS WITHIN THE MUNICIPAL BOUNDARIES OF THE CITY OF HAVELOCK

DOCUMENT NOT CONSIDERED FINAL  
UNTIL ALL SIGNATURES ARE COMPLETED

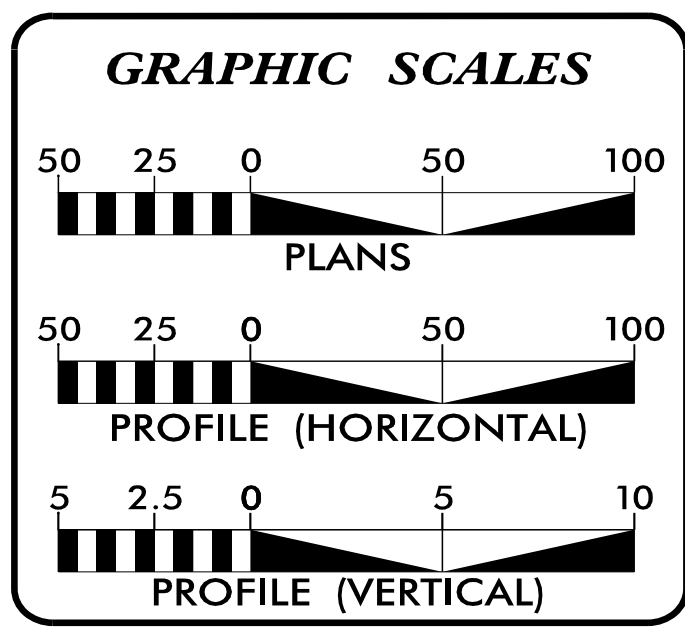

INDEX OF SHEETS	
SHEET NO.:	DESCRIPTION:
UC-1	TITLE SHEET
UC-2	UTILITY SYMBOLGY
UC-3	UTILITY NOTES
UC-3A THRU UC-3D	UTILITY DETAILS
UC-4	UTILITY CONSTRUCTION SHEETS
UC-5 THRU UC-7	UTILITY PROFILE SHEETS

**WATER AND SEWER OWNERS ON PROJECT**

(1) WATER & SEWER - CITY OF HAVELOCK

PREPARED IN THE OFFICE OF

**Kimley»Horn**

NC LICENSE #F-0102  
421 FAYETTEVILLE STREET, SUITE 600  
RALEIGH, NORTH CAROLINA 27601  
PHONE: (919) 877-2000

Nate Harvey, P.E. CONSULTANT CONTACT #1

SEAL

12/13/2022

**DIVISION OF HIGHWAYS UTILITIES UNIT**  
1555 MAIL SERVICES CENTER  
RALEIGH, NC 27699-1555  
PHONE (919) 707-6690  
FAX (919) 250-4151











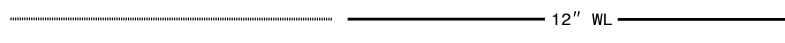













Nabil Hamdan REGIONAL UTILITIES ENGINEER  
Kelvin Martin, E.I. UTILITIES ENGINEER  
Tanga Sampson REGIONAL UTILITIES COORDINATOR  
Kelvin Martin, E.I. UTILITIES COORDINATOR





# STATE OF NORTH CAROLINA DIVISION OF HIGHWAYS

## UTILITIES PLAN SHEET SYMBOLS





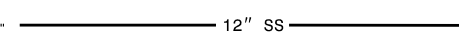
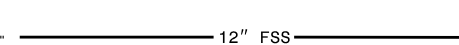

### PROPOSED WATER SYMBOLS





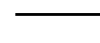
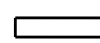

Water Line (Sized as Shown)	
11 1/4 Degree Bend	
22 1/2 Degree Bend	
45 Degree Bend	
90 Degree Bend	
Plug	
Tee	
Cross	
Reducer	
Gate Valve	
Butterfly Valve	
Tapping Valve	
Line Stop	
Line Stop with Bypass	
Blow Off	
Fire Hydrant	
Relocate Fire Hydrant	
Remove Fire Hydrant	REM FH
Water Meter	
Relocate Water Meter	
Remove Water Meter	REM WM
Water Pump Station	
RPZ Backflow Preventer	
DCV Backflow Preventer	
Relocate RPZ Backflow Preventer	
Relocate DCV Backflow Preventer	

### PROPOSED SEWER SYMBOLS

Gravity Sewer Line (Sized as Shown)	
Force Main Sewer Line (Sized as Shown)	
Manhole (Sized per Note)	
Sewer Pump Station	

### PROPOSED MISCELLANEOUS UTILITIES SYMBOLS

Power Pole	
Telephone Pole	
Joint Use Pole	
Telephone Pedestal	
Utility Line by Others (Type as Shown)	
Trenchless Installation	
Encasement by Open Cut	
Encasement	

Thrust Block	
Air Release Valve	
Utility Vault	
Concrete Pier	
Steel Pier	
Plan Note	
Pay Item Note	

NOTE  
PAY ITEM

### EXISTING UTILITIES SYMBOLS

Power Pole		*Underground Power Line	
Telephone Pole		*Underground Telephone Cable	
Joint Use Pole		*Underground Telephone Conduit	
Utility Pole		*Underground Fiber Optics Telephone Cable	
Utility Pole with Base		*Underground TV Cable	
H-Frame Pole		*Underground Fiber Optics TV Cable	
Power Transmission Line Tower		*Underground Gas Pipeline	
Water Manhole		Aboveground Gas Pipeline	
Power Manhole		*Underground Water Line	
Telephone Manhole		Aboveground Water Line	
Sanitary Sewer Manhole		*Underground Gravity Sanitary Sewer Line	
Hand Hole for Cable		Aboveground Gravity Sanitary Sewer Line	
Power Transformer		*Underground SS Forced Main Line	
Telephone Pedestal		Underground Unknown Utility Line	
CATV Pedestal		SUE Test Hole	
Gas Valve		Water Meter	
Gas Meter		Water Valve	
Located Miscellaneous Utility Object		Fire Hydrant	
Abandoned According to Utility Records	AATUR	Sanitary Sewer Cleanout	
End of Information	E.O.I.		

\*For Existing Utilities  
Utility Line Drawn from Record (Type as Shown)   
Designated Utility Line (Type as Shown) 

5/14/99





5/14/99

PROJECT REFERENCE NO.	SHEET NO.
BR-0074A	UC-3A
DESIGNED BY: NLH	
DRAWN BY: GCS	
CHECKED BY: CPM	
APPROVED BY: NLH	
REVISED:	
NORTH CAROLINA DEPARTMENT OF TRANSPORTATION UTILITIES ENGINEERING SEC. PHONE: (919) 707-6690 FAX: (919) 250-4151	
UTILITY CONSTRUCTION PLANS ONLY	

**UTILITY CONSTRUCTION**

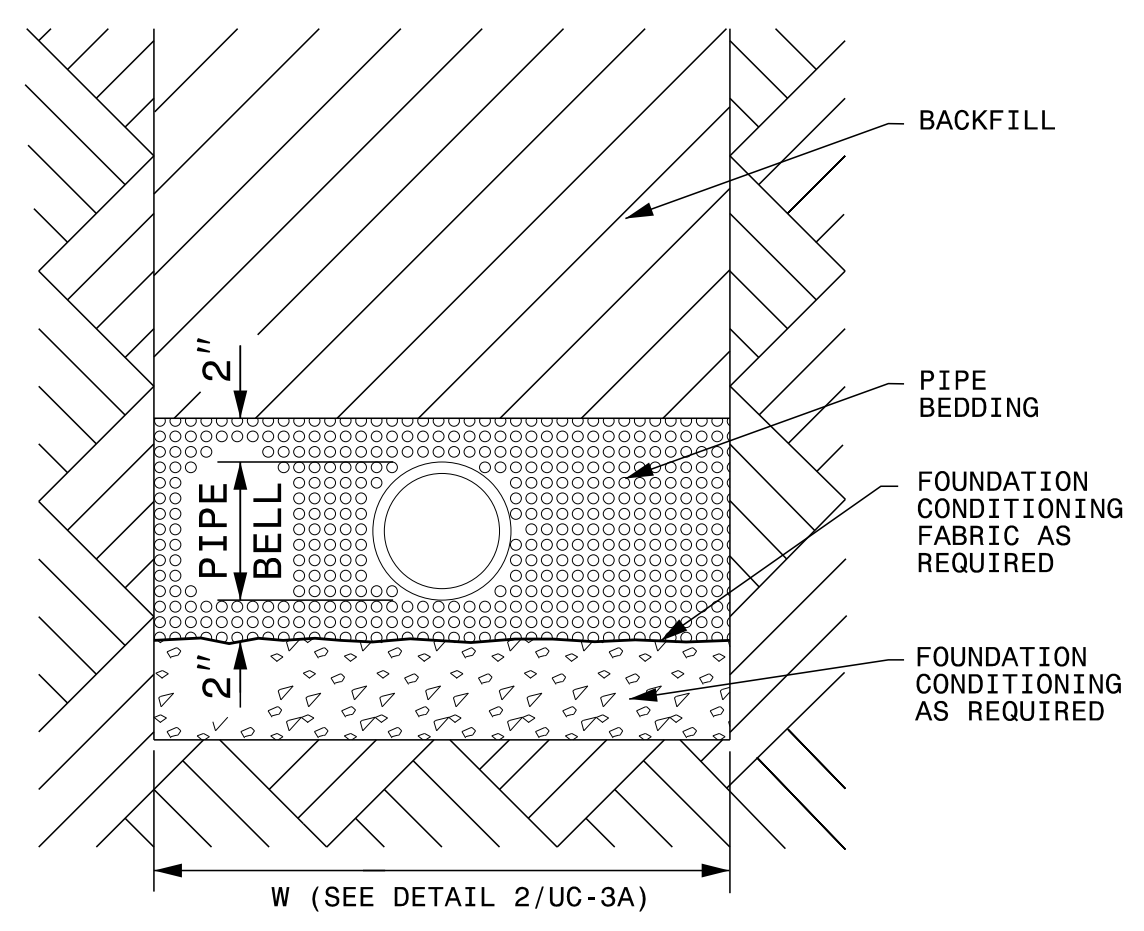

- NOTES:
1. PLACE FOUNDATION CONDITIONING MATERIAL BELOW BEDDING IF REQUIRED, AS DIRECTED BY ENGINEER.
  2. PIPE SHALL BE BEDDED IN SELECT MATERIAL, CLASS II (TYPE 1) OR CLASS III.
  3. TRENCH SHALL BE BACKFILLED IN LOOSE 6" LAYERS COMPACTED TO TOP OF TRENCH USING LOCAL EXCAVATED MATERIAL IF APPROVED BY THE ENGINEER, OR SELECT MATERIAL.
  4. ALL MATERIAL SHALL BE FREE OF ROCKS, FOREIGN MATERIAL, AND FROZEN EARTH.
  5. COMPACTION SHALL BE TO APPROXIMATELY 95% DENSITY IN ACCORDANCE WITH AASHTO T-99 AS MODIFIED BY THE DEPARTMENT OF TRANSPORTATION.

1	TRENCH DETAIL
UC-3A	SCALE: N.T.S.

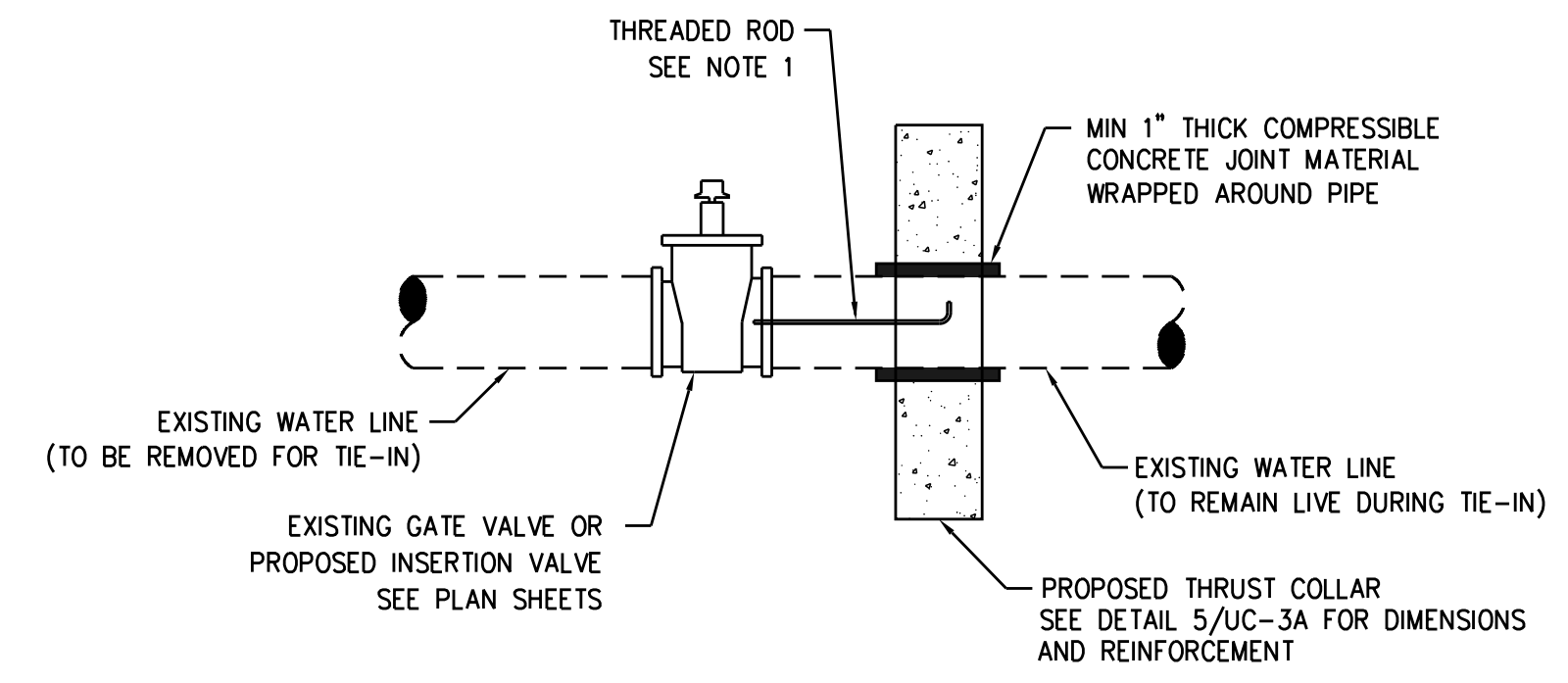

- NOTES:
1. MECHANICALLY FASTEN THREADED ROD TO REBAR WITHIN THRUST COLLAR AND TO EXISTING/PROPOSED VALVE. USE MIN TWO HOT-DIPPED GALV STEEL OR STAINLESS 3/4" RODS.
  2. THE THRUST COLLAR SHALL BE ALLOWED TO CURE A MINIMUM OF 3 DAYS BEFORE GATE VALVE IS CLOSED.
  3. AFTER THRUST COLLAR HAS CURED, VALVE MAY BE CLOSED, PIPE CUT AND REMOVED, AND NEW PIPE INSTALLED PER DETAIL 3/UC-3A.

2	INSERTION VALVE
UC-3A	SCALE: N.T.S.

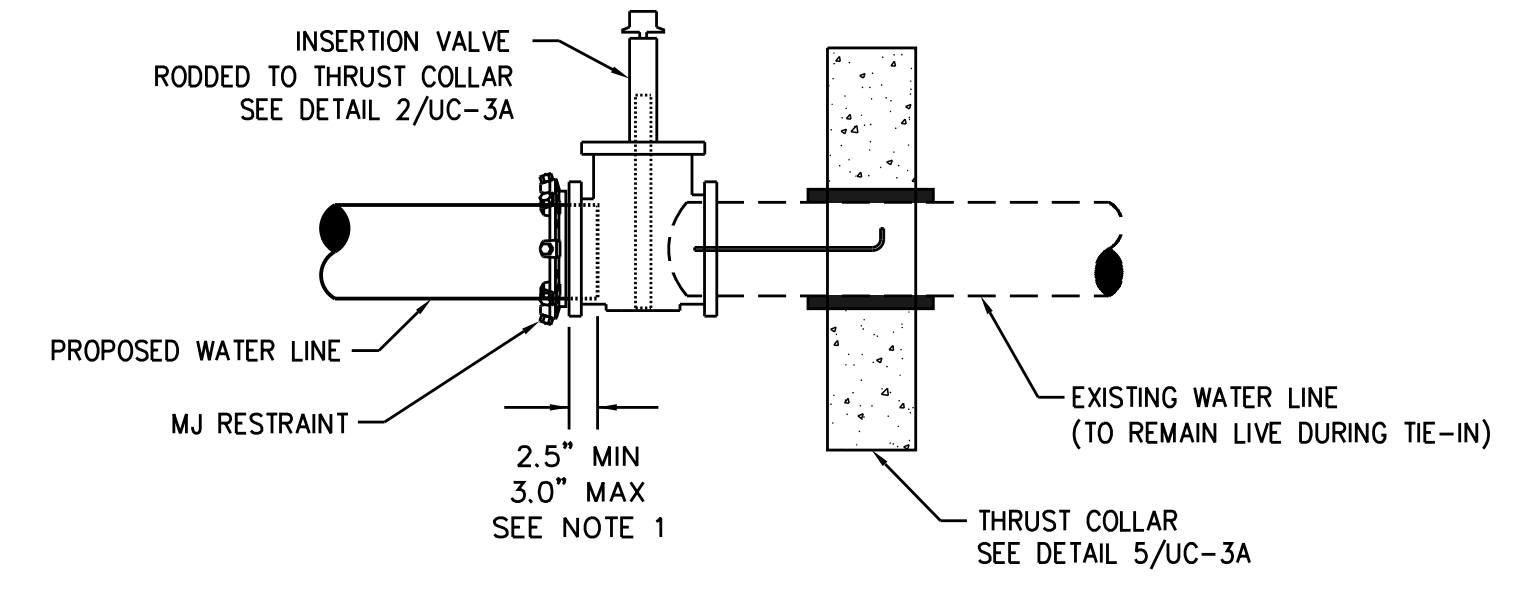

- NOTES:
1. CONNECT PROPOSED PIPING TO INSERTION VALVE BY INSERTING PROPOSED PIPE PLAIN END A MINIMUM OF 2.5" AND A MAXIMUM OF 3" BEYOND THE FACE OF THE VALVE'S MJ OPENING AND SECURING IN PLACE WITH A WEDGE RESTRAINING GLAND AND MJ SEAL. PROPOSED PIPE SHALL NOT INTERFERE WITH VALVE OPERATION.

3	PROPOSED PIPE TO INSERTION VALVE CONNECTION
UC-3A	SCALE: N.T.S.

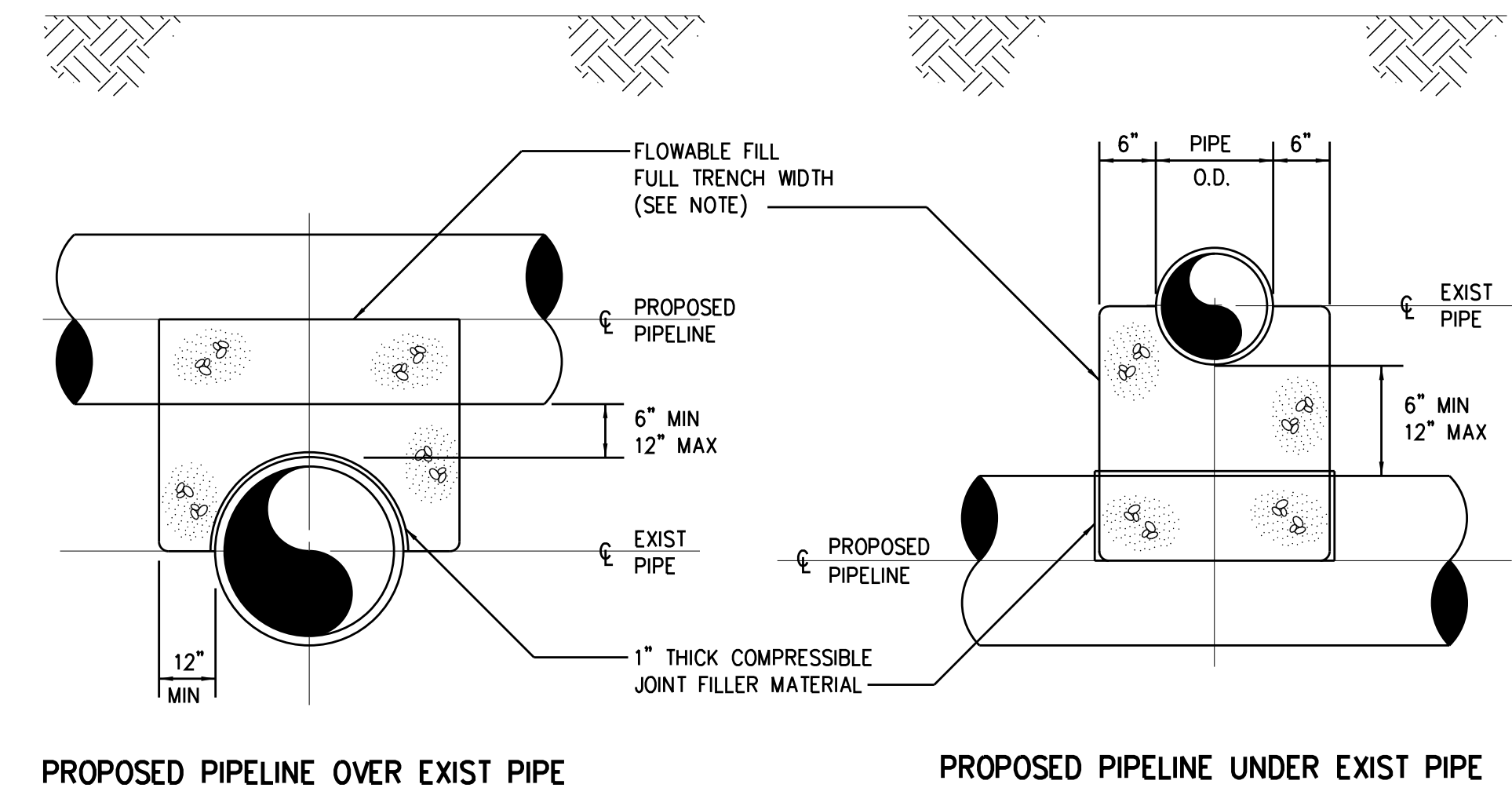

NOTE: NO ENCASEMENT REQUIRED FOR VERTICAL SEPARATION GREATER THAN 12"

4	PIPE CROSSING DETAIL
UC-3A	SCALE: N.T.S.

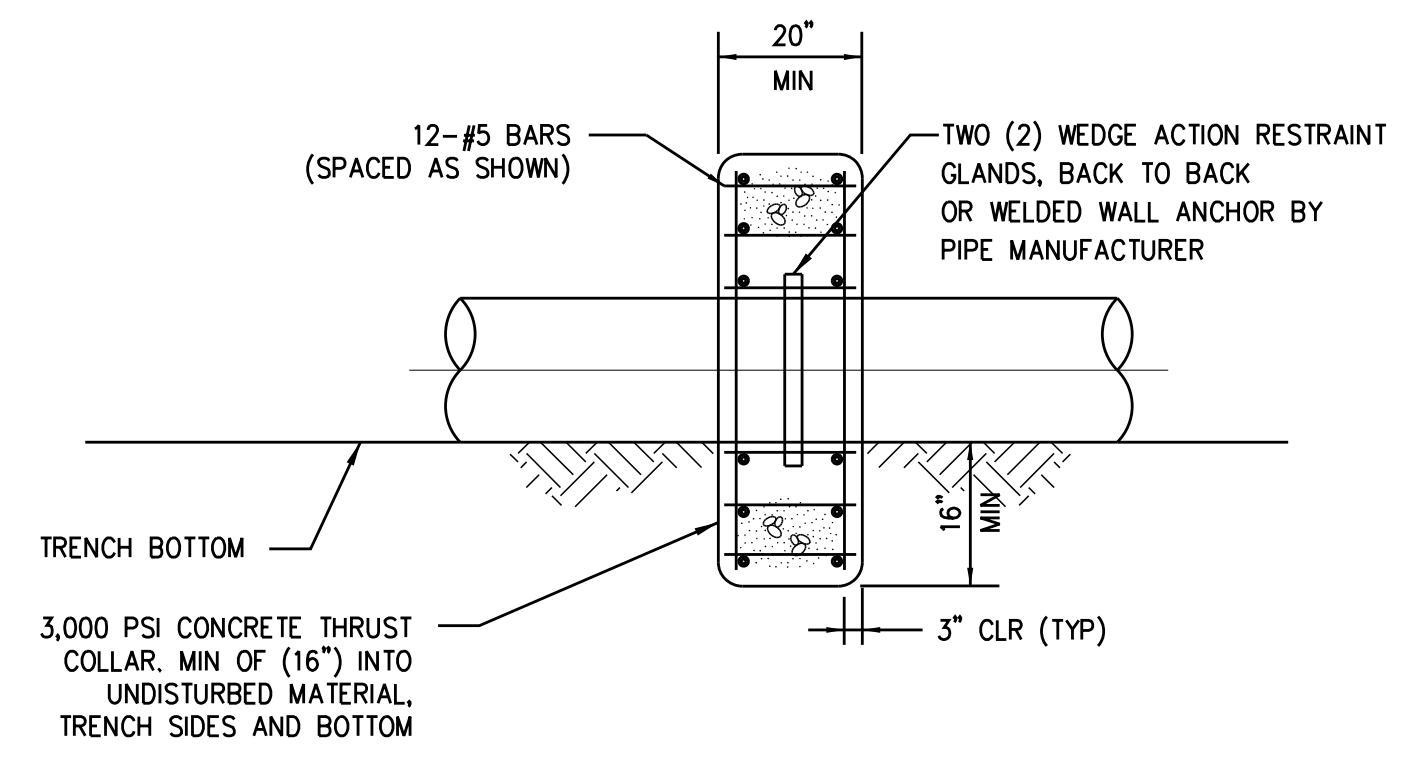

ELEVATION 1

- NOTES:
1. STABILIZE BASE IF REQUIRED, AS DIRECTED BY ENGINEER, TO SUPPORT THRUST COLLAR.
  2. SOIL BEARING CAPACITY ASSUMED TO BE 2,000 PSF.

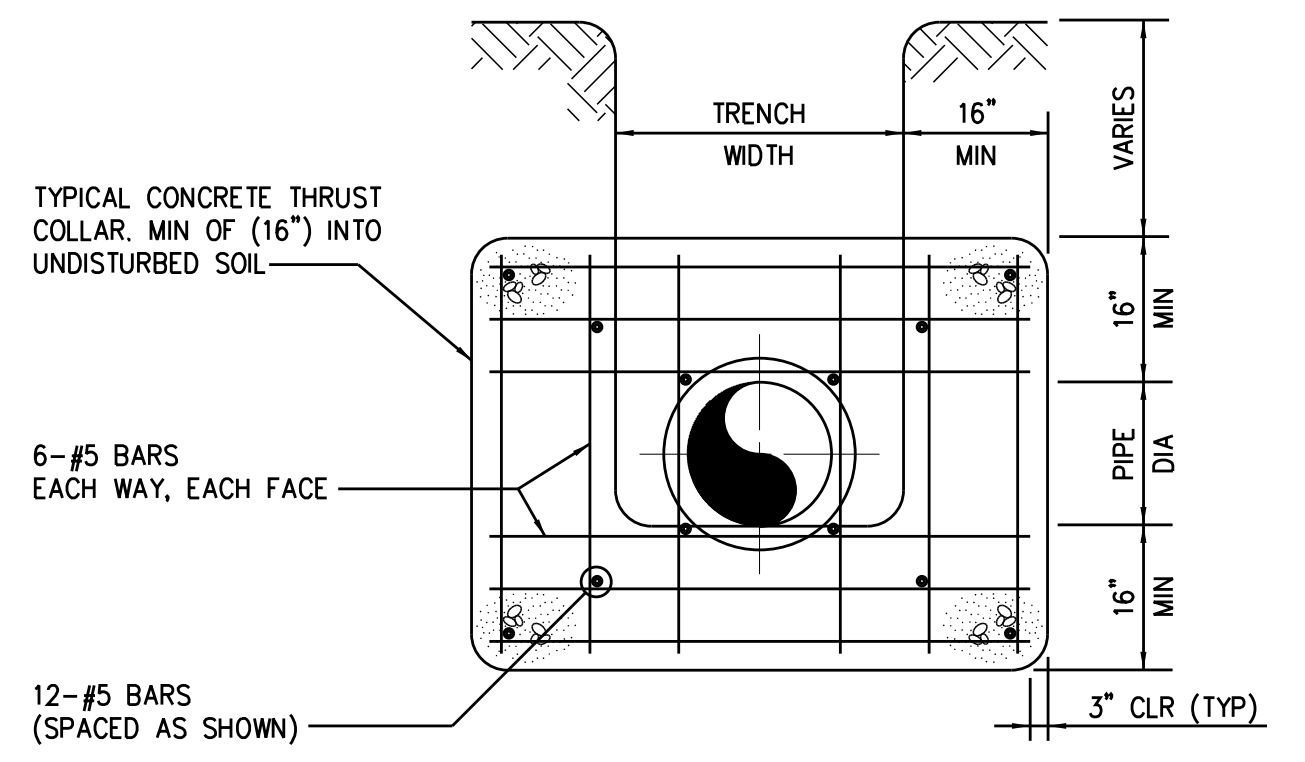

ELEVATION 2

5	THRUST COLLAR
UC-3A	SCALE: N.T.S.

5/14/99

**UTILITY CONSTRUCTION**

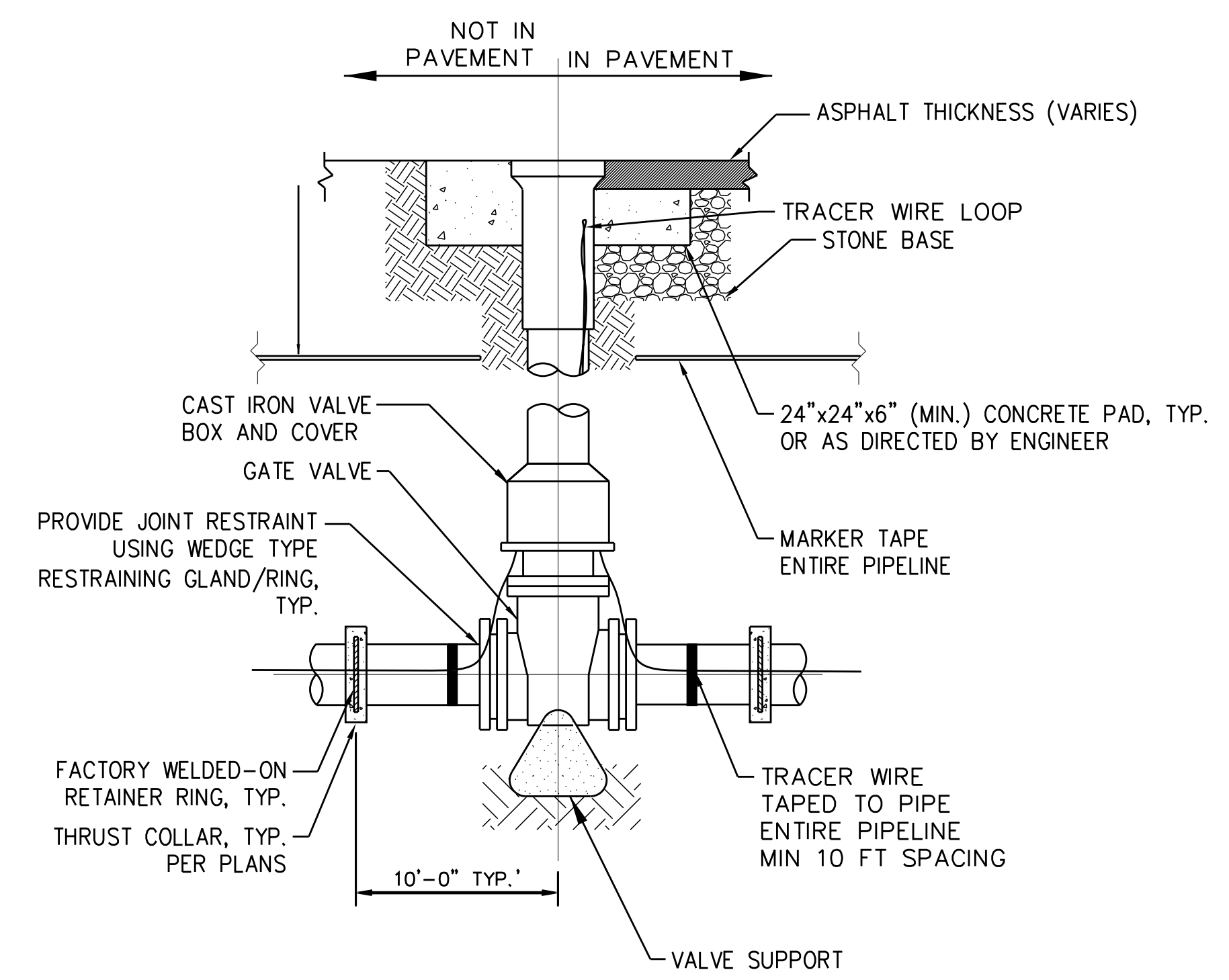

**NOTES:**  
 1. PROVIDE HDPE INSERTS IN ALL VALVE BOXES.

**1 GATE VALVE ASSEMBLY (FOR 4" THRU 12" VALVES)**  
 UC-3B SCALE: N.T.S.

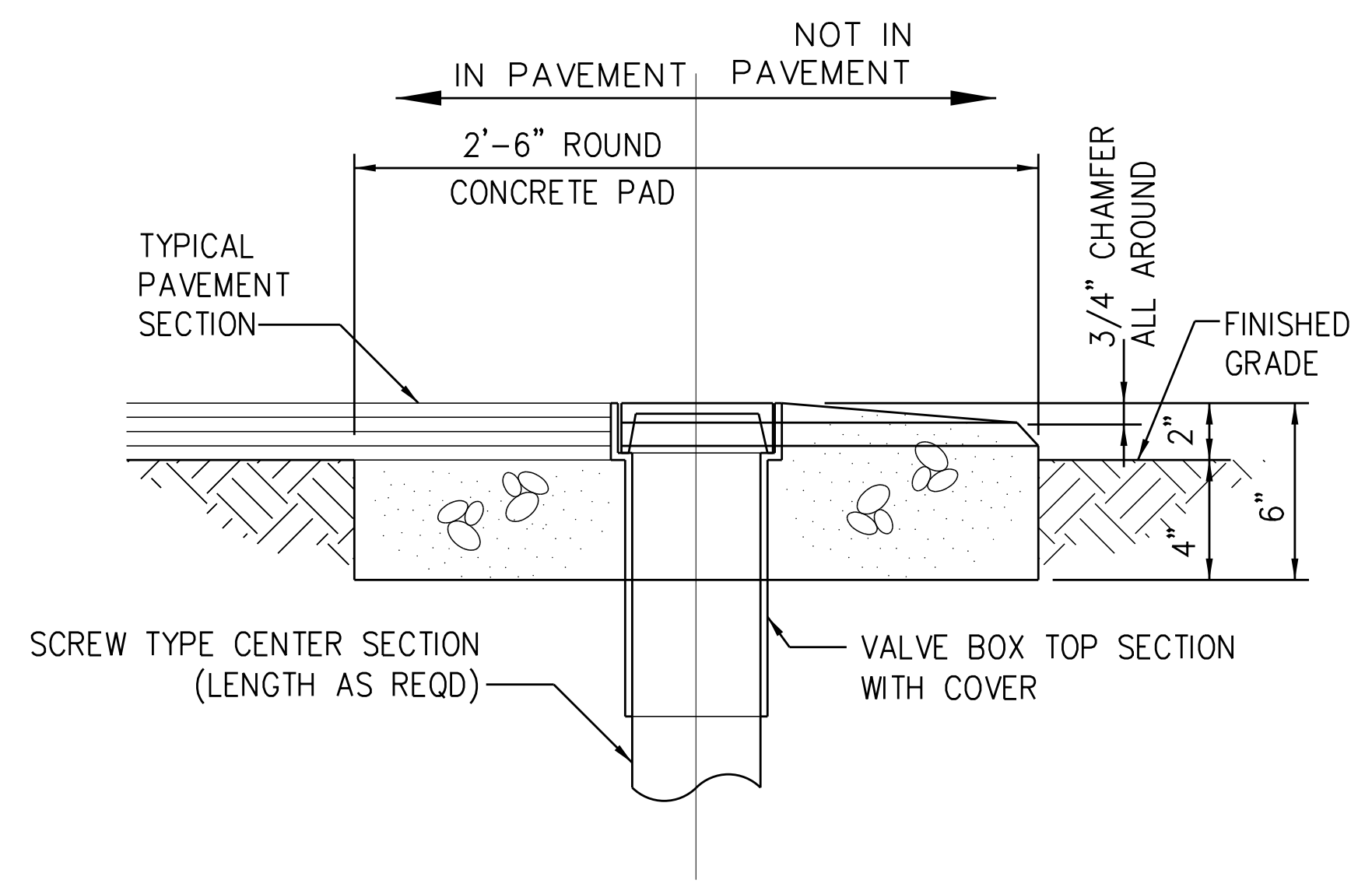

**2 VALVE BOX PAD**  
 UC-3B SCALE: N.T.S.

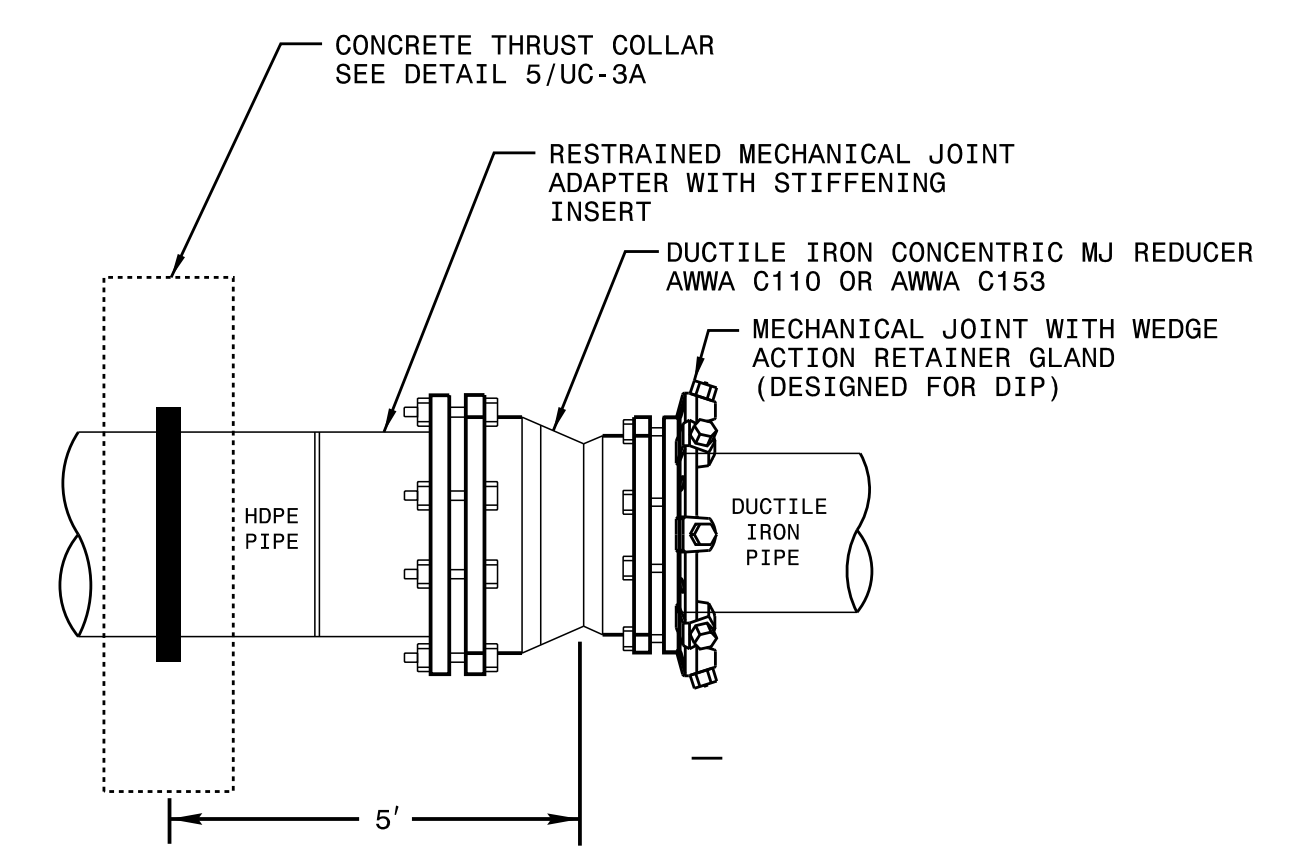

**3 HDPE TO DI PIPE TRANSITION DETAIL**  
 UC-3B SCALE: N.T.S.

DESIGN PRESSURE		
200 PSI		
PIPE SIZE	ROD DIA	NUMBER REQ'D
4" TO 8"	3/4"	2
10" TO 20"	3/4"	4
24"	3/4"	6
30"	1"	6
36"	1"	8

- INSTALL THREADED RODS PER THE SCHEDULE ABOVE WHERE INDICATED ON THE DRAWINGS. RODS SHALL BE EQUALLY SPACED AROUND PIPE AND BE MECHANICALLY FASTENED TO THE PIPES, FITTINGS, THRUST COLLARS, OR APURTENANCES NECESSARY FOR RESTRAINT.
- THREADED RODS FOR RESTRAINT OF PIPE DIAMETERS LARGER THAN 12" SHALL BE ASTM A193 (GRADE B7). ALL OTHER THREADED RODS SHALL BE ASTM A36.

**4 THREADED ROD SCHEDULE FOR THRUST RESTRAINT**  
 UC-3B SCALE: N.T.S.

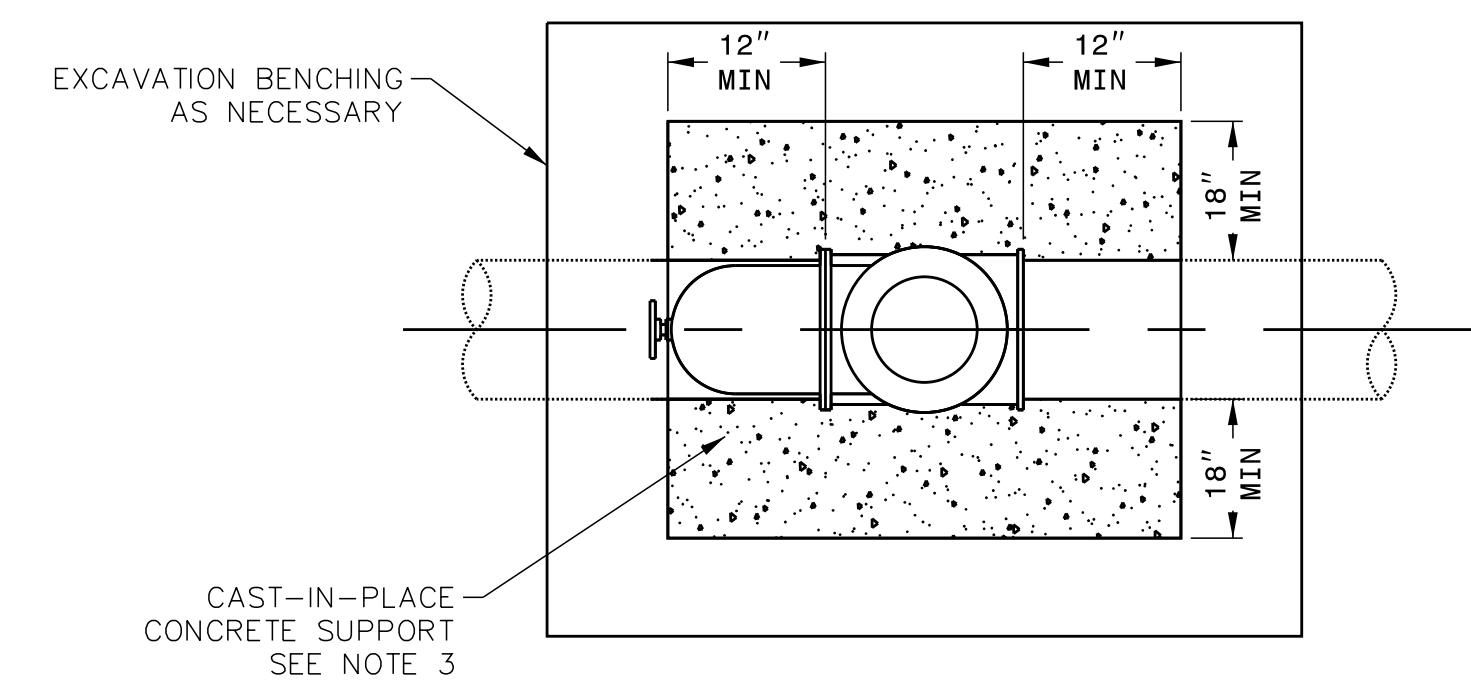

**LINESTOP ASSEMBLY--PLAN**

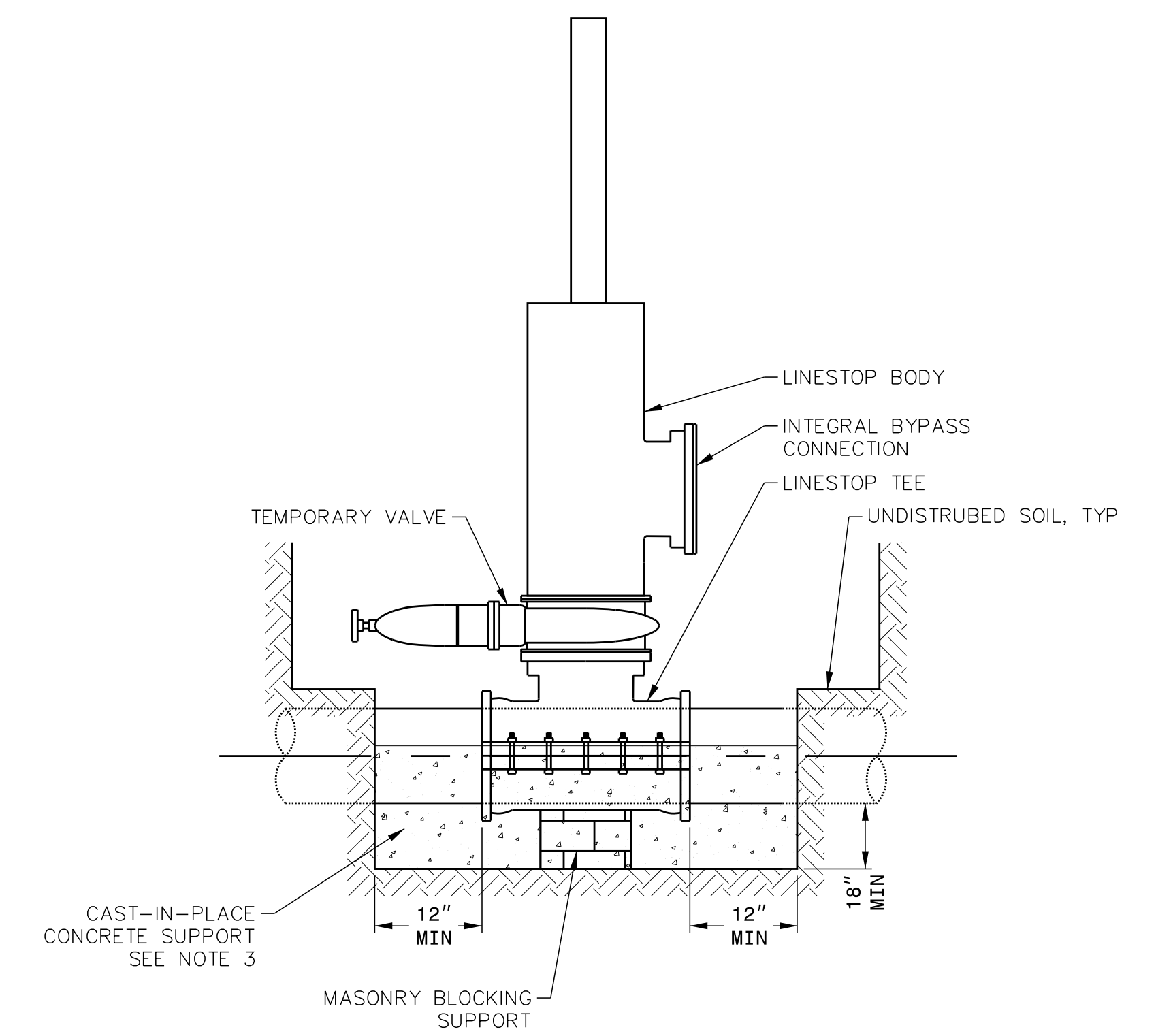

**LINESTOP ASSEMBLY--PROFILE**

- NOTES:**
- LINESTOP AND CONCRETE SUPPORT MUST BE LOCATED ENTIRELY WITHIN ONE PIPE JOINT.
  - ISOLATE ALL METALLIC COMPONENTS OF LINE STOP FROM CONCRETE WITH POLYETHYLENE SHEETING.
  - CAST-IN-PLACE CONCRETE SUPPORT SHALL CURE MINIMUM 3 DAYS PRIOR TO ENGAGING LINE STOP AND STARTING BYPASS.

**5 LINE STOP WITH BYPASS**  
 UC-3B SCALE: N.T.S.



5/14/99

**UTILITY CONSTRUCTION**

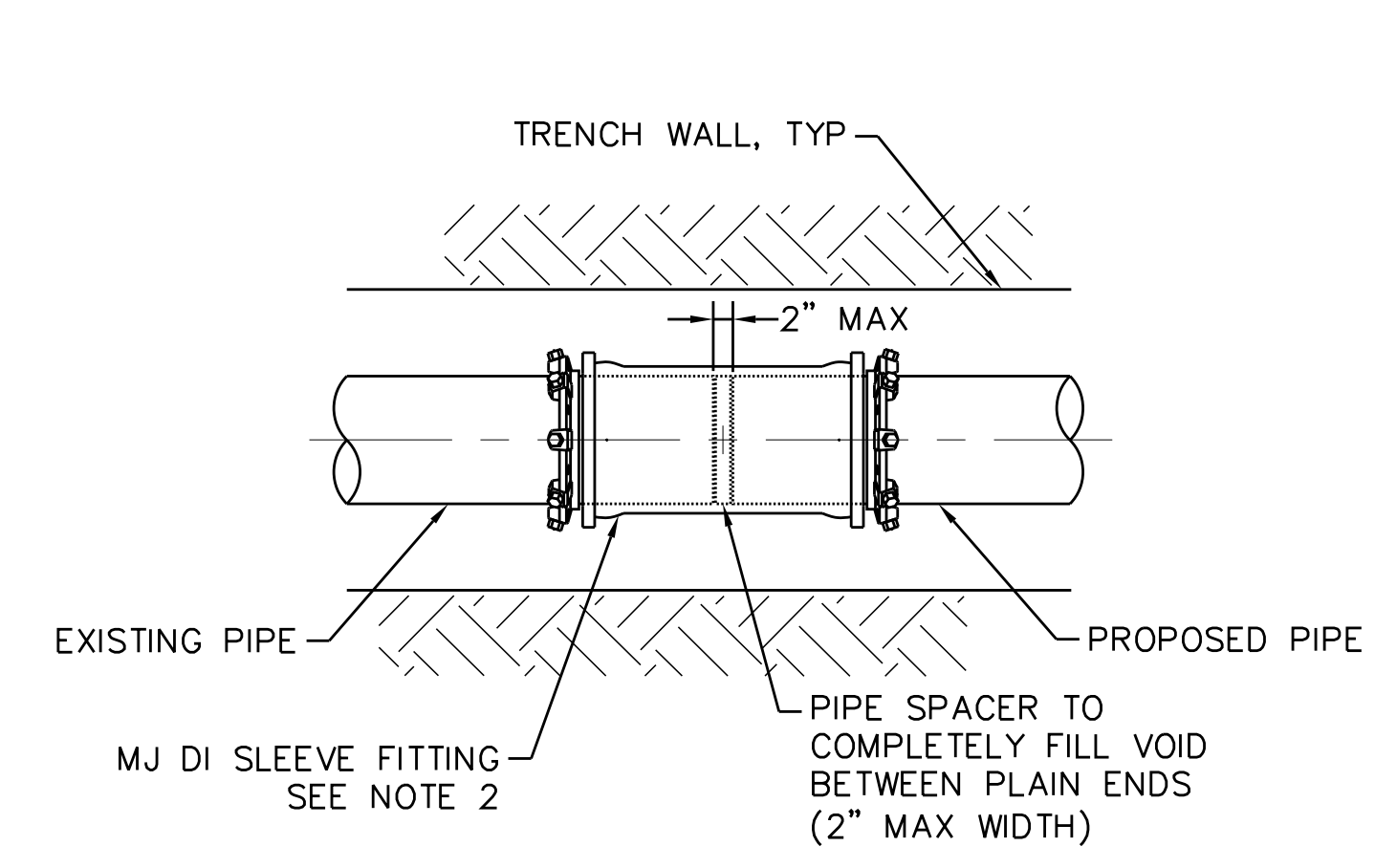

PLAN - MJ SLEEVE

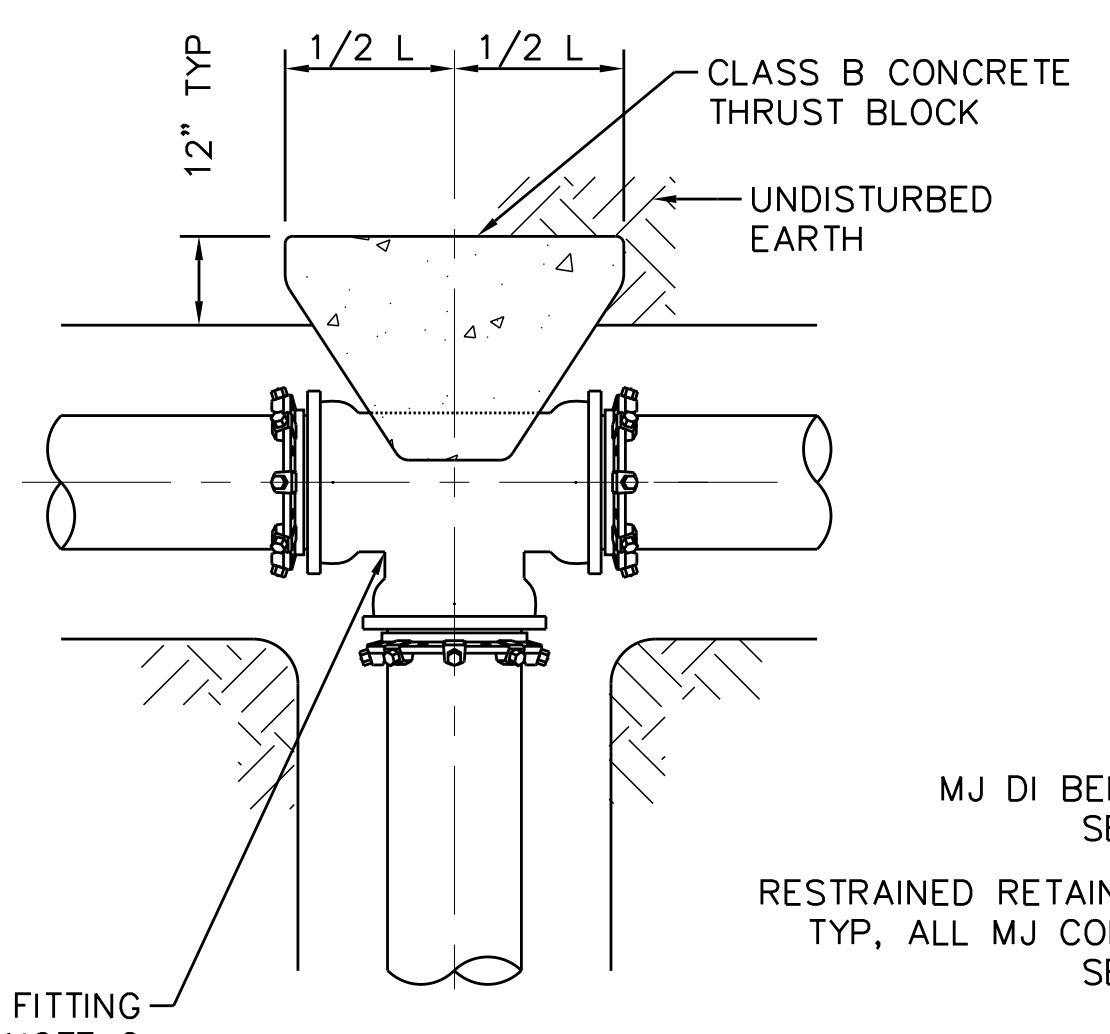

PLAN - MJ TEE

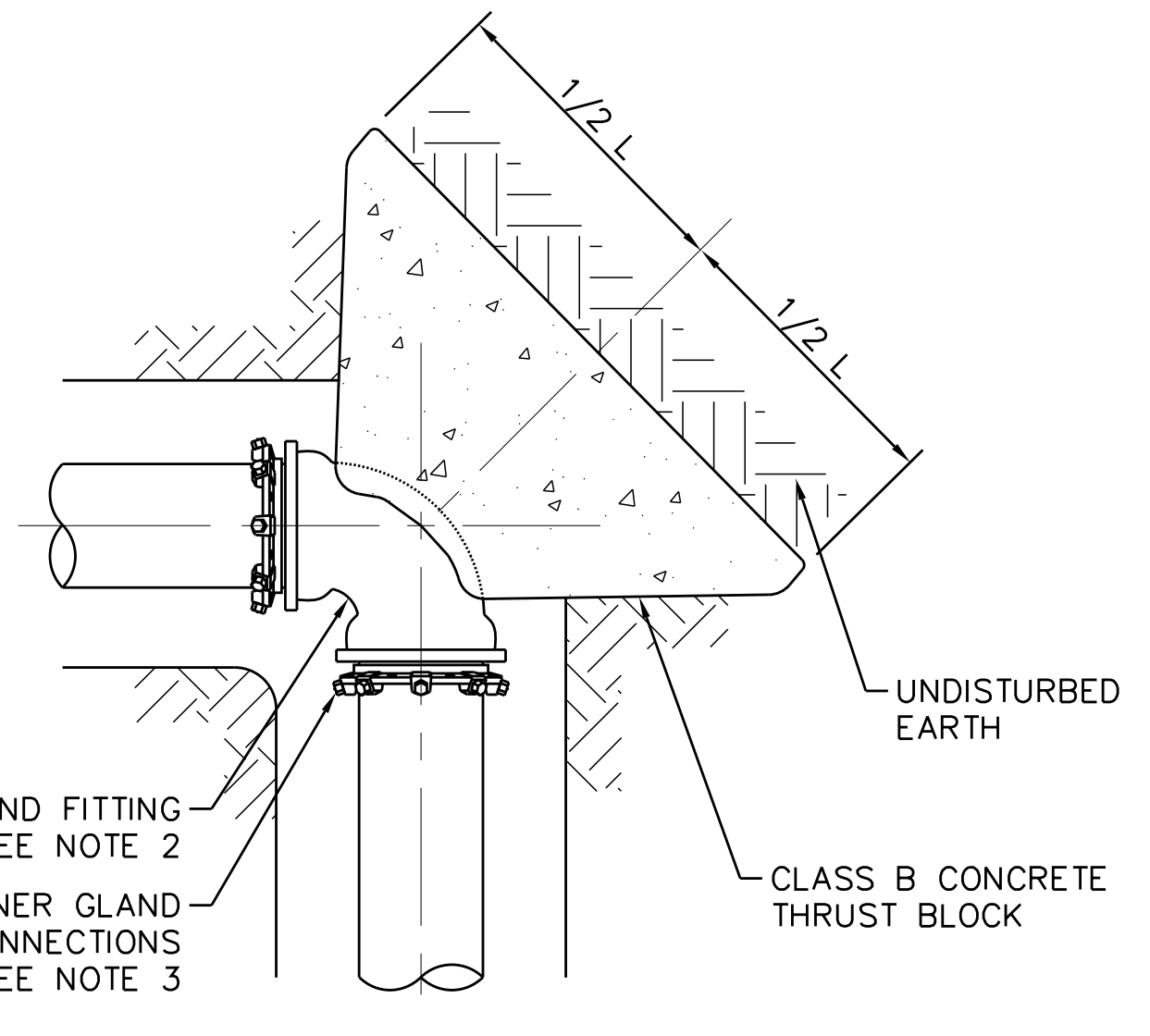

PLAN - MJ BEND

TRENCH EXCAVATION LIMITS		
INTERNAL DIAMETER OF PIPE	W	
	MAX	W=MIN
4"-6"	3'-9"	2'-0"
8"-10"	3'-9"	2'-2"
12"	3'-9"	O.D.+2'
14"-16"	4'-2"	O.D.+2'
18"	4'-4"	O.D.+2'
20", 21"	4'-8"	O.D.+2'
24"	4'-11"	O.D.+2'
27"	5'-9"	O.D.+2'
30"	6'-7"	O.D.+2'
36"	7'-4"	O.D.+2'

W = TRENCH WIDTH AT BOTTOM OF PIPE. TRENCH SIDE SLOPES SHALL BE IN ACCORDANCE WITH OSHA REQUIREMENTS.

**2 TRENCH EXCAVATION LIMITS**  
 SCALE: N.T.S.

PIPE SIZE (IN)	CONCRETE THRUST BLOCK SCHEDULE (DIMENSIONS IN FT)							
	FITTING							
	90° / TEE		45°		22.5°		11.25°	
	H	W	H	W	H	W	H	W
4	2.0	4.0	1.5	2.9	1.0	2.1	0.7	1.5
6	2.0	4.0	1.5	2.9	1.0	2.1	0.7	1.5
8	2.6	5.2	1.9	3.8	1.4	2.7	1.0	1.9
12	3.8	7.6	2.8	5.6	2.0	4.0	1.4	2.8
16	5.0	10.0	3.7	7.4	2.6	5.3	1.9	3.7
24	7.4	14.9	5.5	11.0	3.9	7.8	2.8	5.5
30	9.2	18.5	6.8	13.6	4.9	9.7	3.4	6.9
36	11.1	22.1	8.1	16.3	5.8	11.6	4.1	8.2

- NOTES:
- THRUST BLOCK DIMENSIONS BASED ON AVERAGE SOIL PASSIVE BEARING STRENGTH OF 2000 PSF USING SF OF 1.5 AND DESIGN TEST PRESSURE OF 200 PSI. FOR PIPE SIZES NOT LISTED, USE DIMENSIONS FOR NEXT LARGER PIPE SIZE.
  - ALL FITTINGS SHALL BE DUCTILE IRON MECHANICAL JOINT (DI MJ) OF THE SAME OR HIGHER PRESSURE RATING AS THE HOST PIPE AND SHALL BE RESTRAINED AGAINST THRUST VIA RESTRAINT GLANDS AND CONCRETE THRUST BLOCKING.
  - RESTRAINT GLANDS DESIGNED FOR THE INTENDED USE. RESTRAINT GLANDS SHALL CONSIST OF MULTIPLE GRIPPING WEDGES INCORPORATED INTO A FOLLOWER GLAND AND BOLT-ACTUATED BY TORQUE-LIMITING TWIST OFF NUTS.
  - DIRECT CONTACT BETWEEN CONCRETE AND FITTINGS, PIPE, OR HARDWARE SHALL NOT BE PERMITTED. THRUST BLOCK SHALL NOT OBSTRUCT ACCESS TO RESTRAINT GLAND BOLTS.

**1 THRUST RESTRAINT FOR FITTINGS**  
 SCALE: N.T.S.

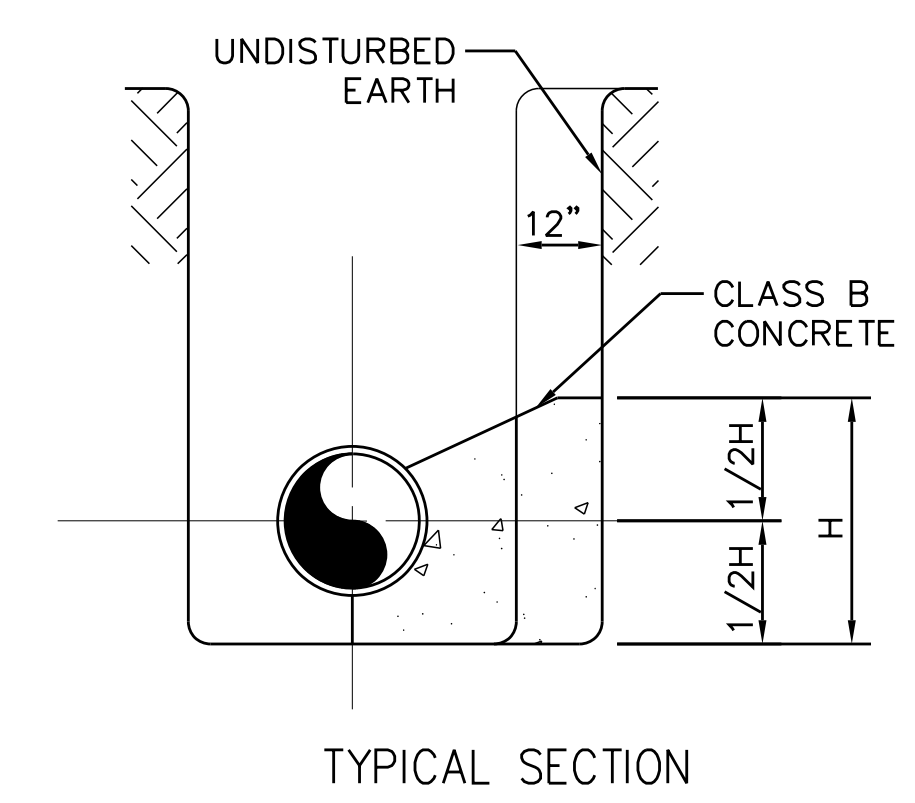

TYPICAL SECTION

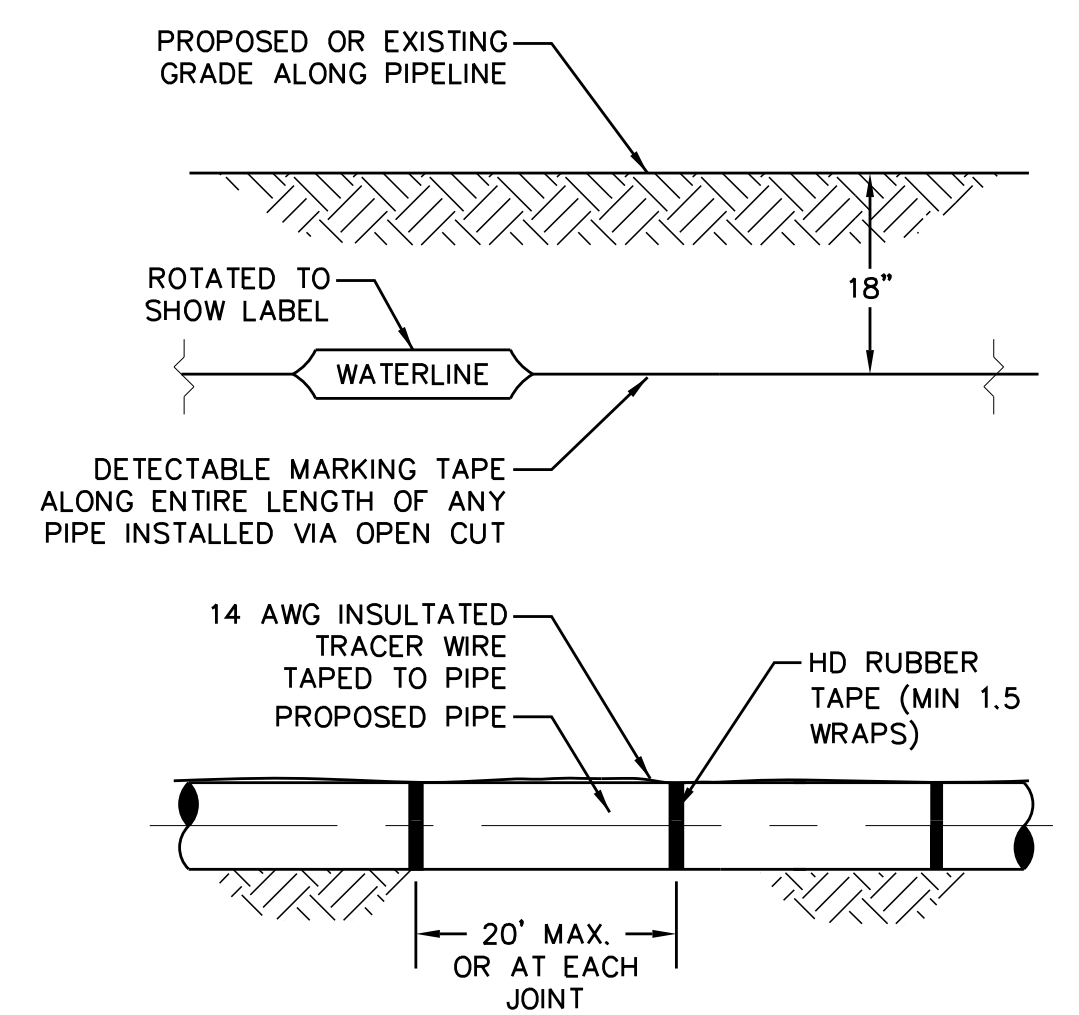

**3 DETECTABLE MARKING TAPE AND WIRE**  
 SCALE: N.T.S.





5/14/2022

- NOTES:
1. SHUTDOWN SHALL ONLY BE PERMITTED ON ONE WATER LINE CROSSING SW PRONG SLOCUM CREEK AT ANY GIVEN TIME.
  2. SEQUENCE WORK TO MINIMIZE DURATION OF LINE STOP WITH BYPASS USAGE. CONSTRUCT FINAL TIE-IN OF -FSS1- AT BOTH ENDS SIMULTANEOUSLY.
  3. COORDINATE WORK WITH ADJACENT DRY UTILITY RELOCATIONS BY OTHERS.
  4. ALL NON-UTILITY WORK SHOWN ON THIS SHEET IS PART OF THE FUTURE BR-0074 BRIDGE REPLACEMENT PROJECT AND IS SHOWN FOR REFERENCE ONLY.
  5. CONNECT PROPOSED 6" LINEAR FEET OF 12" FORCE MAIN (INCLUDING 12"x6" WYE FOR CONNECTION OF -FSS1-) TO EXISTING 12" FORCE MAIN WITH 12" LONG BODY MJ SLEEVES.
  6. DIRECTIONAL DRILL SEGMENTS ARE SHOWN AS STARTING AT STATION 10+00 OF THE APPLICABLE UTILITY LINE. CONTRACTOR MAY CHOOSE TO DRILL FROM EITHER DIRECTION. THE ENTIRETY OF THE WORK MUST BE CONTAINED WITHIN EXISTING RIGHTS-OF-WAY.

PROJECT REFERENCE NO. BR-0074A SHEET NO. UC-4

DESIGNED BY: NLH  
DRAWN BY: GCS  
CHECKED BY: CPM  
APPROVED BY: NLH

REVISED:

NORTH CAROLINA DEPARTMENT OF TRANSPORTATION

UTILITIES ENGINEERING SEC. PHONE: (919) 707-6690 FAX: (919) 250-4151

UTILITY CONSTRUCTION PLANS ONLY

**Kimley Horn**  
421 FAYETTEVILLE STREET, SUITE 600  
RALEIGH, NC 27601

SEAL  
045249  
M. J. HARRIS, P.E.  
REGISTERED PROFESSIONAL ENGINEER  
NO. 13173/2022

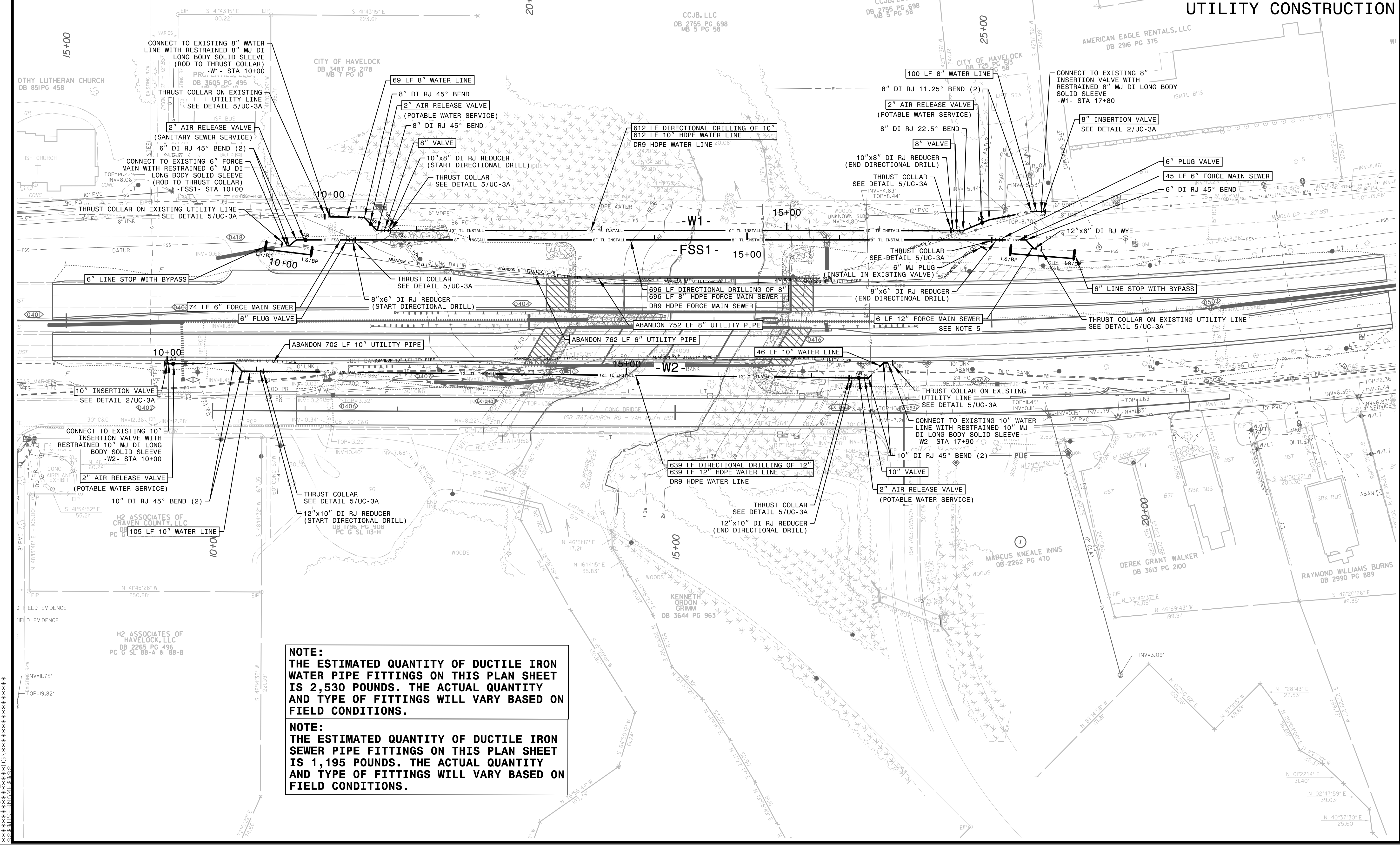

**NOTE:**  
THE ESTIMATED QUANTITY OF DUCTILE IRON WATER PIPE FITTINGS ON THIS PLAN SHEET IS 2,530 POUNDS. THE ACTUAL QUANTITY AND TYPE OF FITTINGS WILL VARY BASED ON FIELD CONDITIONS.

**NOTE:**  
THE ESTIMATED QUANTITY OF DUCTILE IRON SEWER PIPE FITTINGS ON THIS PLAN SHEET IS 1,195 POUNDS. THE ACTUAL QUANTITY AND TYPE OF FITTINGS WILL VARY BASED ON FIELD CONDITIONS.



**NOTE:**  
 PRIOR TO COMMENCING ANY WORK ON ANY TRENCHLESS  
 INSTALLATION ON THIS PROJECT, PROVIDE A DESIGN FOR  
 THE TRENCHLESS INSTALLATION CERTIFIED BY AN  
 ENGINEER LICENSED BY THE STATE OF NORTH CAROLINA, AS  
 REQUIRED BY SUBARTICLE 1550-3(B) OF THE STANDARD  
 SPECIFICATIONS.

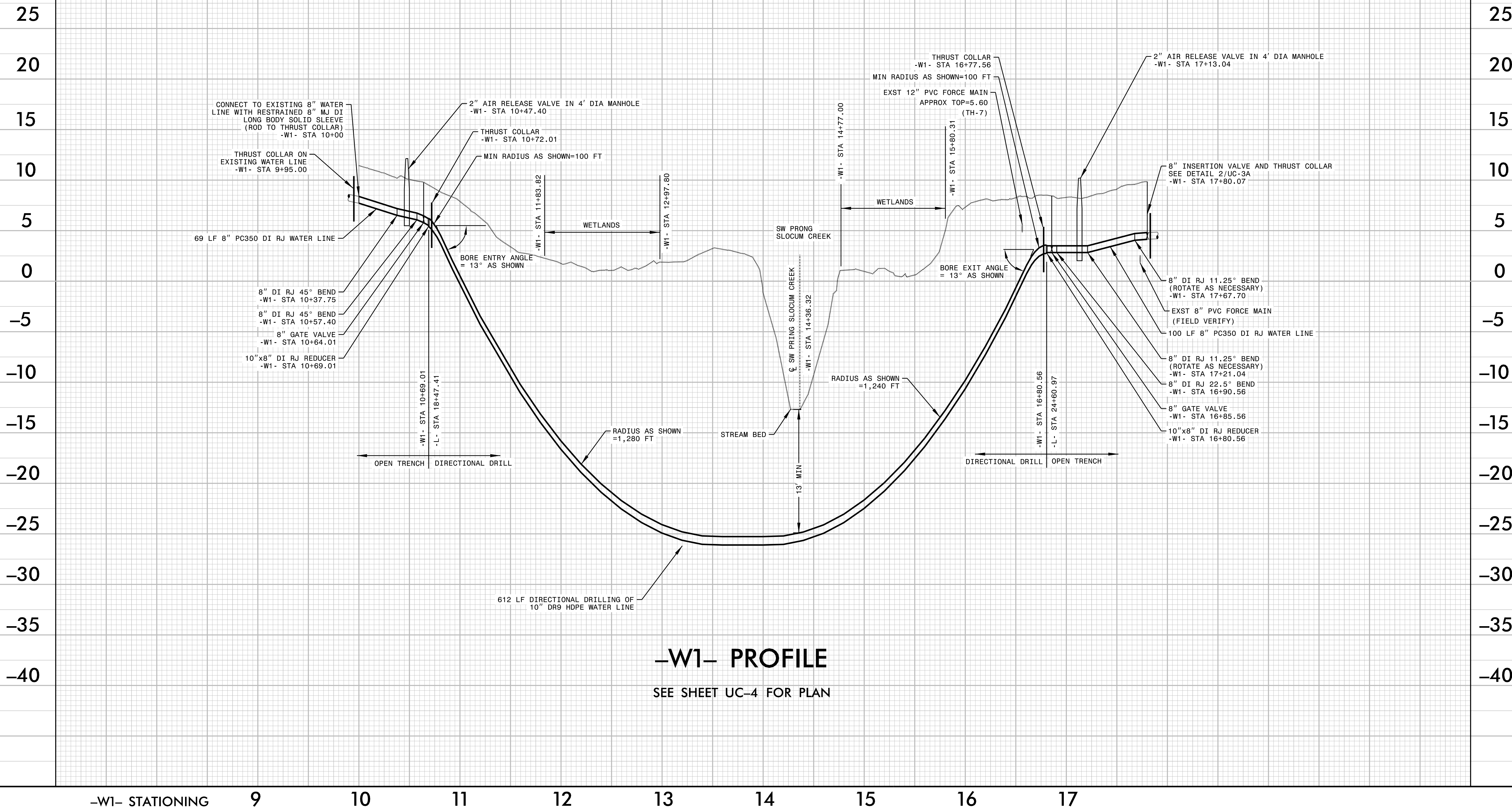

<b>Kimley»Horn</b> 421 FAYETTEVILLE STREET, SUITE 600 RALEIGH, NC 27601		PROJECT REFERENCE NO. BR-0074A	SHEET NO. UC-5
DESIGNED BY: NLH DRAWN BY: GCS CHECKED BY: CPM APPROVED BY: NLH REVISED:			
NORTH CAROLINA DEPARTMENT OF TRANSPORTATION		UTILITIES ENGINEERING SEC. PHONE: (919)707-6690 FAX: (919)250-4151	

### UTILITY CONSTRUCTION





NOTE:  
 PRIOR TO COMMENCING ANY WORK ON ANY TRENCHLESS  
 INSTALLATION ON THIS PROJECT, PROVIDE A DESIGN FOR  
 THE TRENCHLESS INSTALLATION CERTIFIED BY AN  
 ENGINEER LICENSED BY THE STATE OF NORTH CAROLINA, AS  
 REQUIRED BY SUBARTICLE 1550-3(B) OF THE STANDARD  
 SPECIFICATIONS.

PROJECT REFERENCE NO. BR-0074A		SHEET NO. UC-6
		
421 FAYETTEVILLE STREET, SUITE 600 RALEIGH, NC 27601		
DESIGNED BY: NLH	DRAWN BY: GCS	
CHECKED BY: CPM	APPROVED BY: NLH	
REVISED:		
NORTH CAROLINA DEPARTMENT OF TRANSPORTATION		
UTILITIES ENGINEERING SEC. PHONE: (919)707-6690 FAX: (919)250-4151		12/13/2022 UTILITY CONSTRUCTION PLANS ONLY

### UTILITY CONSTRUCTION

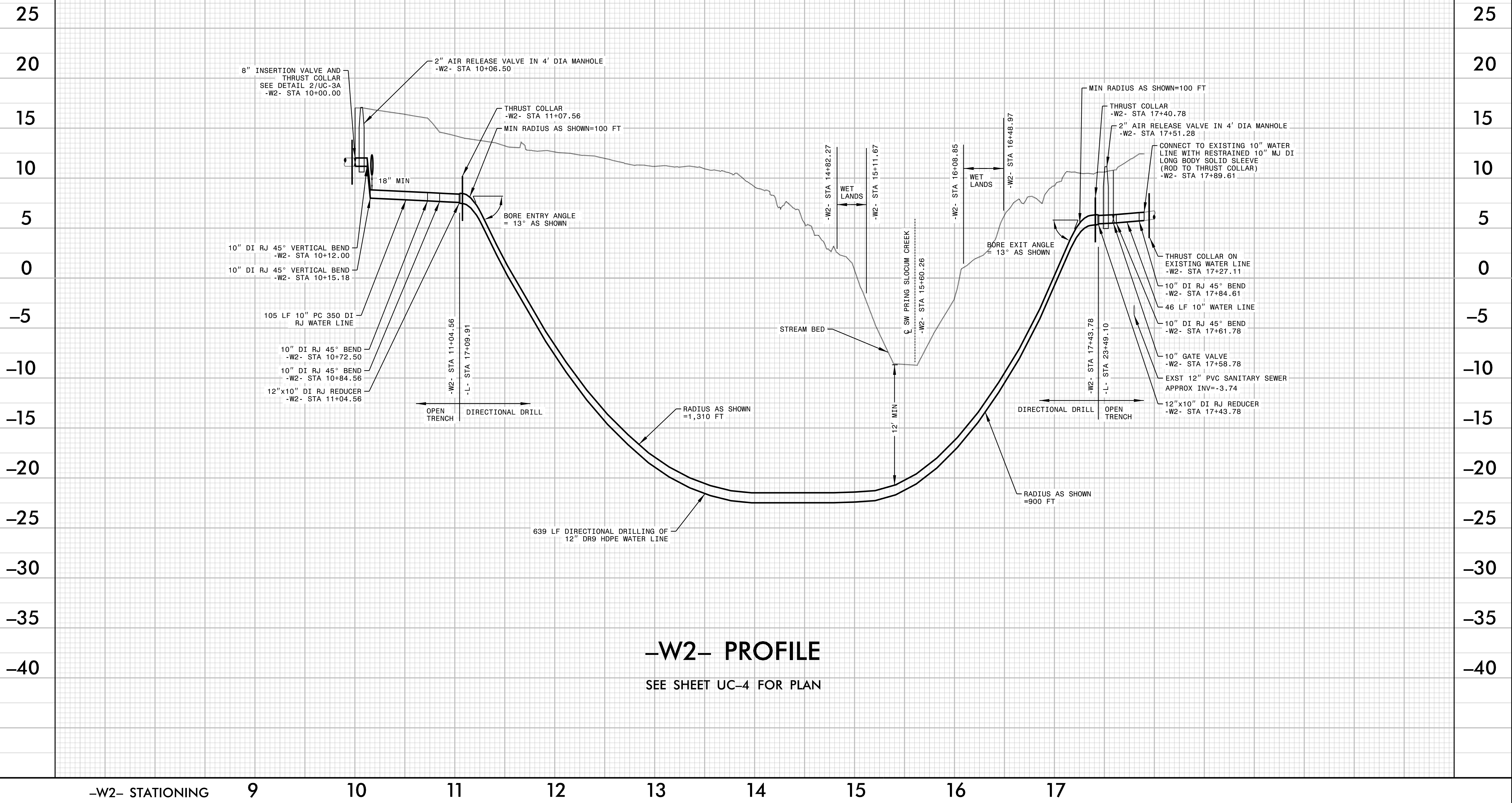

NOTE:  
 PRIOR TO COMMENCING ANY WORK ON ANY TRENCHLESS  
 INSTALLATION ON THIS PROJECT, PROVIDE A DESIGN FOR  
 THE TRENCHLESS INSTALLATION CERTIFIED BY AN  
 ENGINEER LICENSED BY THE STATE OF NORTH CAROLINA, AS  
 REQUIRED BY SUBARTICLE 1550-3(B) OF THE STANDARD  
 SPECIFICATIONS.

PREPARED BY:  
**Kimley»Horn**  
 421 FAYETTEVILLE STREET, SUITE 600  
 RALEIGH, NC 27601

PROJECT REFERENCE NO.	BR-0074A	SHEET NO.	UC-7
DESIGNED BY:	NLH		
DRAWN BY:	GCS		
CHECKED BY:	CPM		
APPROVED BY:	NLH		
REVISED:			
NORTH CAROLINA DEPARTMENT OF TRANSPORTATION		12/13/2022	
UTILITIES ENGINEERING SEC.		UTILITY CONSTRUCTION PLANS ONLY	
PHONE:	(919)707-6690		
FAX:	(919)250-4151		

### UTILITY CONSTRUCTION

25  
20  
15  
10  
5  
0  
-5  
-10  
-15  
-20  
-25  
-30  
-35  
-40

25  
20  
15  
10  
5  
0  
-5  
-10  
-15  
-20  
-25  
-30  
-35  
-40

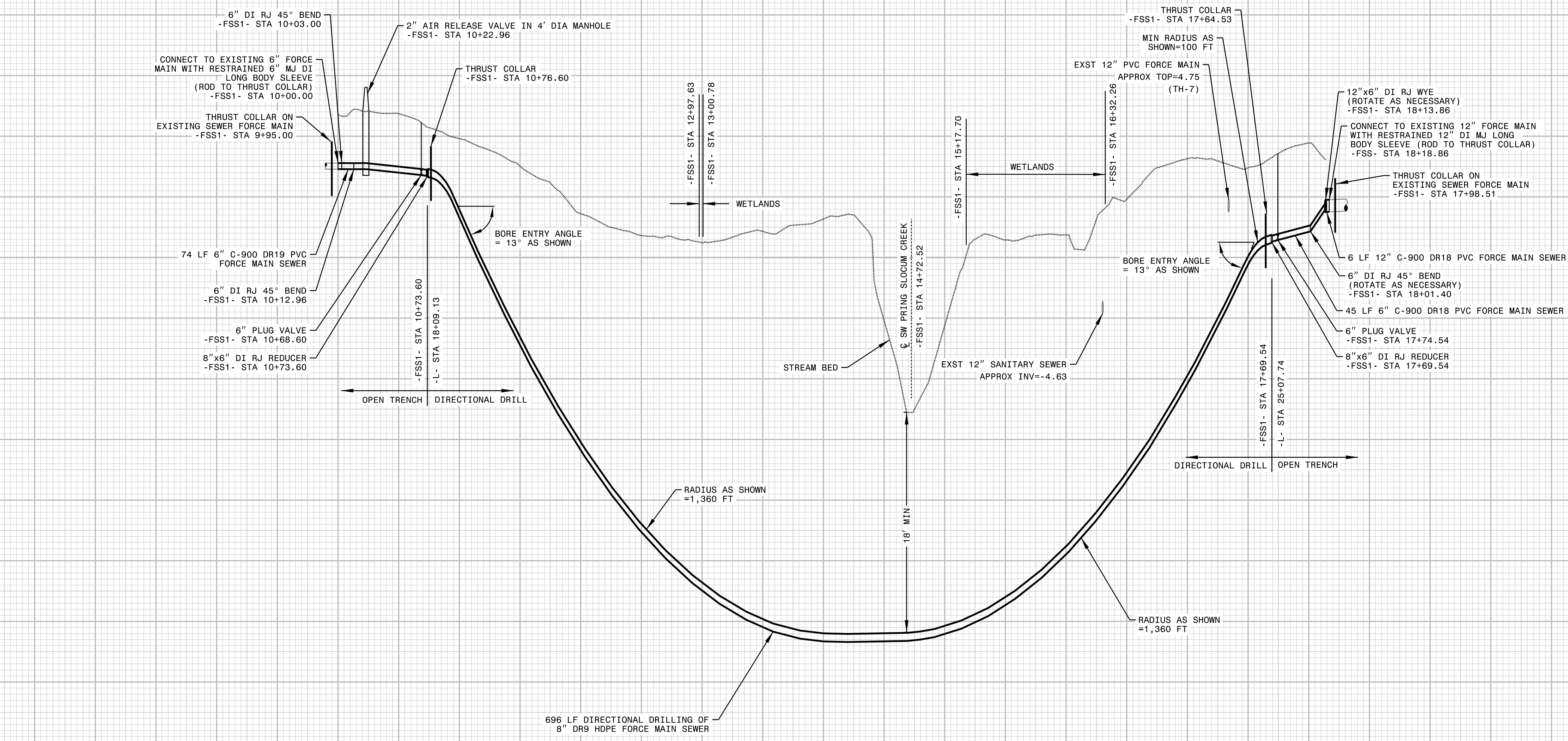

**-FSS1- PROFILE**  
 SEE SHEET UC-4 FOR PLAN

-FSS1- STATIONING    9    10    11    12    13    14    15    16    17    18



**TIP PROJECT: BR-0074**

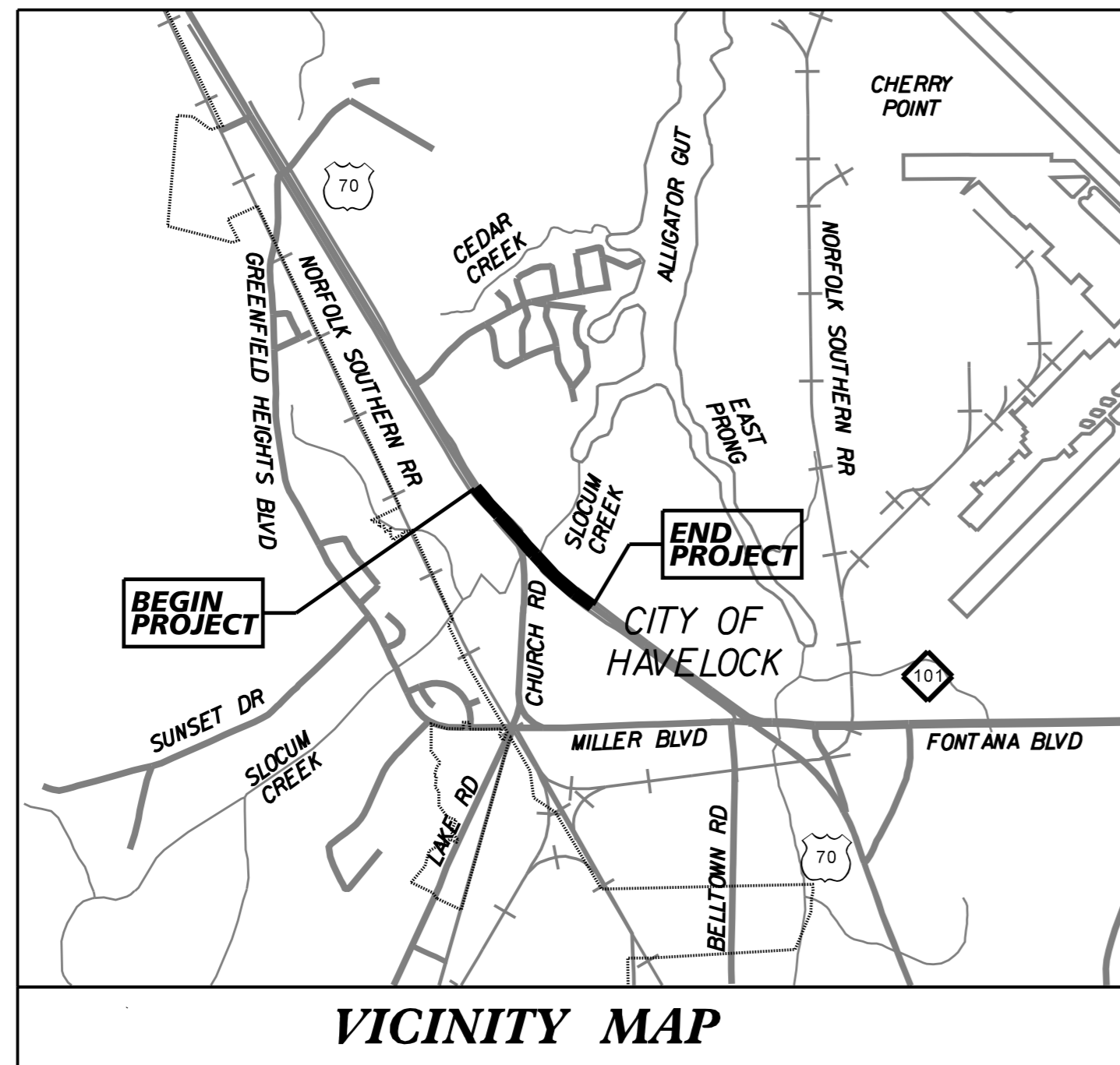

**VICINITY MAP**

— HAVELOCK CITY LIMIT

STATE OF NORTH CAROLINA  
DIVISION OF HIGHWAYS

**UTILITIES BY OTHERS PLANS  
CRAVEN COUNTY**

**LOCATION:** BRIDGES 240091 AND 240092 ON US 70  
OVER S. PRONG SLOCUM CREEK

**TYPE OF WORK:** RELOCATION AND REMOVAL OF AERIAL POWER AND  
COMMUNICATIONS, AND BURIED COMMUNICATIONS  
AND FIBER

T.I.P. NO.	SHEET NO.
BR-0074	UO-1

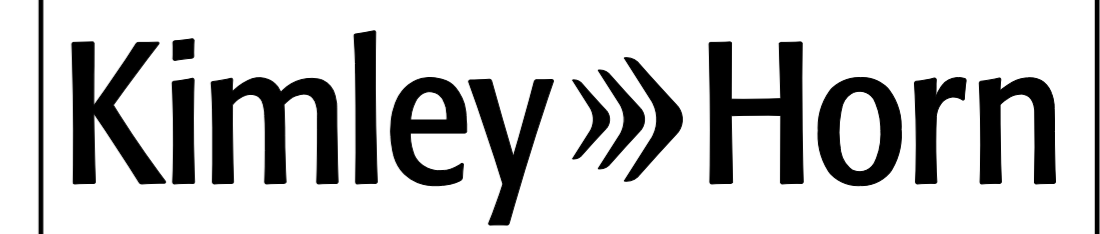

**NOTE:**  
ALL PROPOSED UTILITY WORK SHOWN ON THIS SHEET WILL BE DONE BY OTHERS. NO PAYMENT WILL BE MADE TO THE CONTRACTOR FOR PROPOSED UTILITY WORK SHOWN ON THIS SHEET.

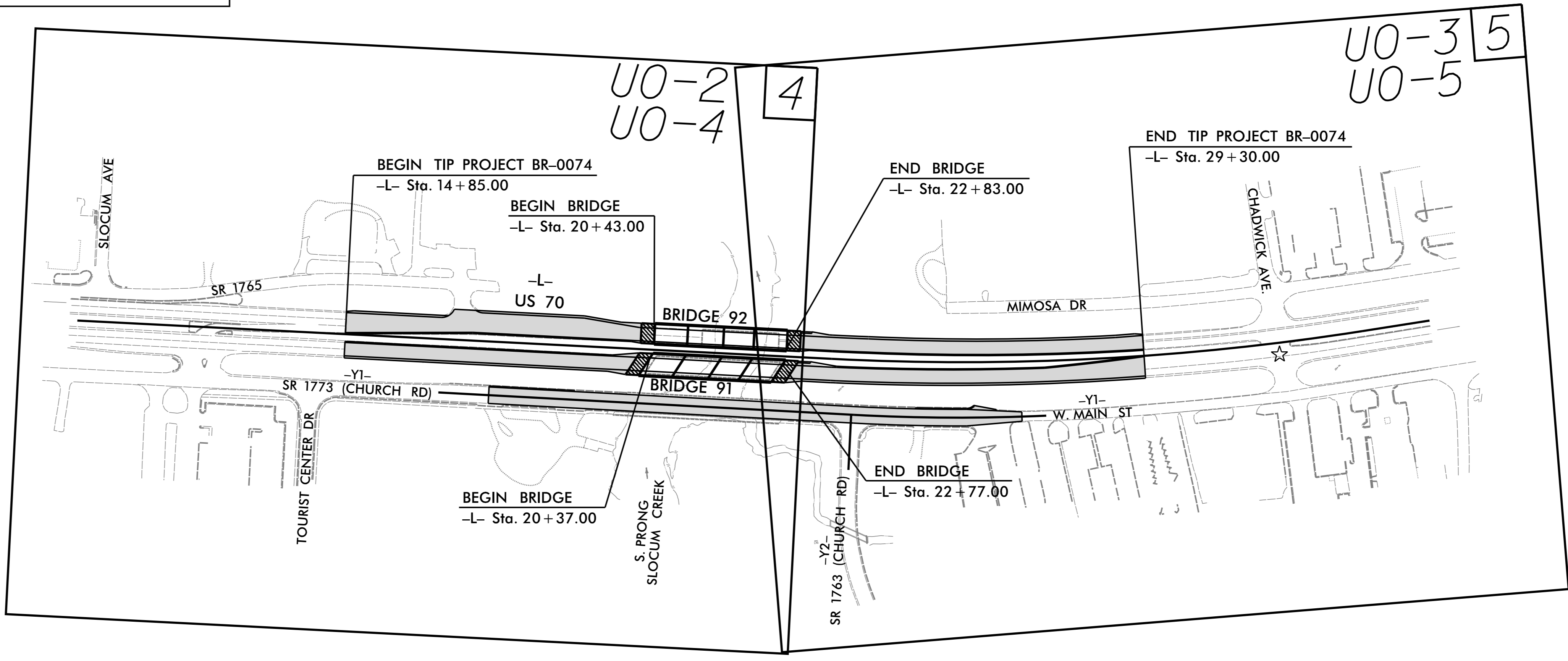
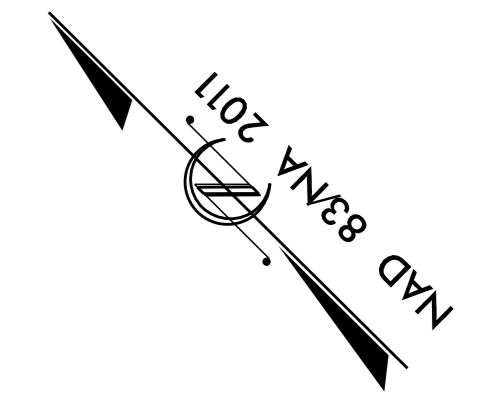

TO NEW BERN

TO NEWPORT

**CONTRACT:**

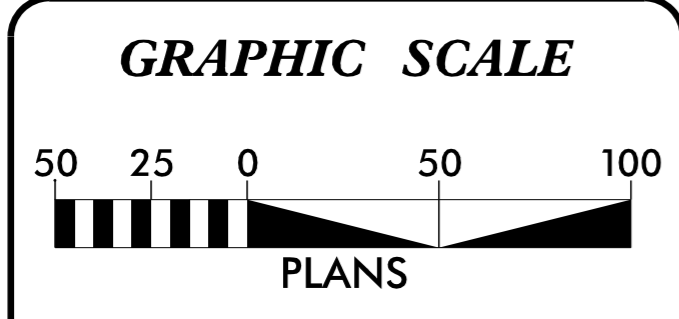

INDEX OF SHEETS	
SHEET NO.	DESCRIPTION
UO-1	TITLE SHEET
UO-2 THRU UO-5	UTILITY BY OTHERS PLAN SHEETS

UTILITY OWNERS ON PROJECT
(A) POWER - DUKE ENERGY (DISTRIBUTION): JOSEPH GRAVES 910-399-3081 EXT: 3936
(B) COMMUNICATIONS - CHARTERSPECTRUM: STAN RAMSAY 252-725-1141
(C) COMMUNICATIONS - BRIGHTSPEED: KEVIN GOODWIN 910-366-2142
(D) COMMUNICATIONS - SEGRA: MIKE WORNOM 803-609-8438
(E) COMMUNICATIONS - CRAVEN COUNTY FIBER: DAVID SHOOK 910-520-9561
(F) COMMUNICATIONS - NCDOT ITS (BROADBAND): STEPHEN C. WARDLE 919-825-2600
(G) COMMUNICATIONS - NCDOT SIGNAL: STEVE HAMILTON 252-439-2816

PREPARED FOR OFFICE OF:  
**DIVISION OF HIGHWAYS  
UTILITIES UNIT  
UTILITIES ENGINEERING**

1555 MAIL SERVICES CENTER  
RALEIGH, NC 27699-1555  
PHONE (919) 707-6690  
FAX (919) 250-4151

NABIL HAMDAN	REGIONAL UTILITIES ENGINEER
TANGA SAMPSON	REGIONAL UTILITIES COORDINATOR
KELVIN MARTIN, EI	UTILITIES ENGINEER



UTILITIES BY OTHERS

**NOTE:**  
 ALL PROPOSED UTILITY WORK SHOWN ON THIS SHEET WILL BE DONE BY OTHERS. NO PAYMENT WILL BE MADE TO THE CONTRACTOR FOR PROPOSED UTILITY WORK SHOWN ON THIS SHEET.

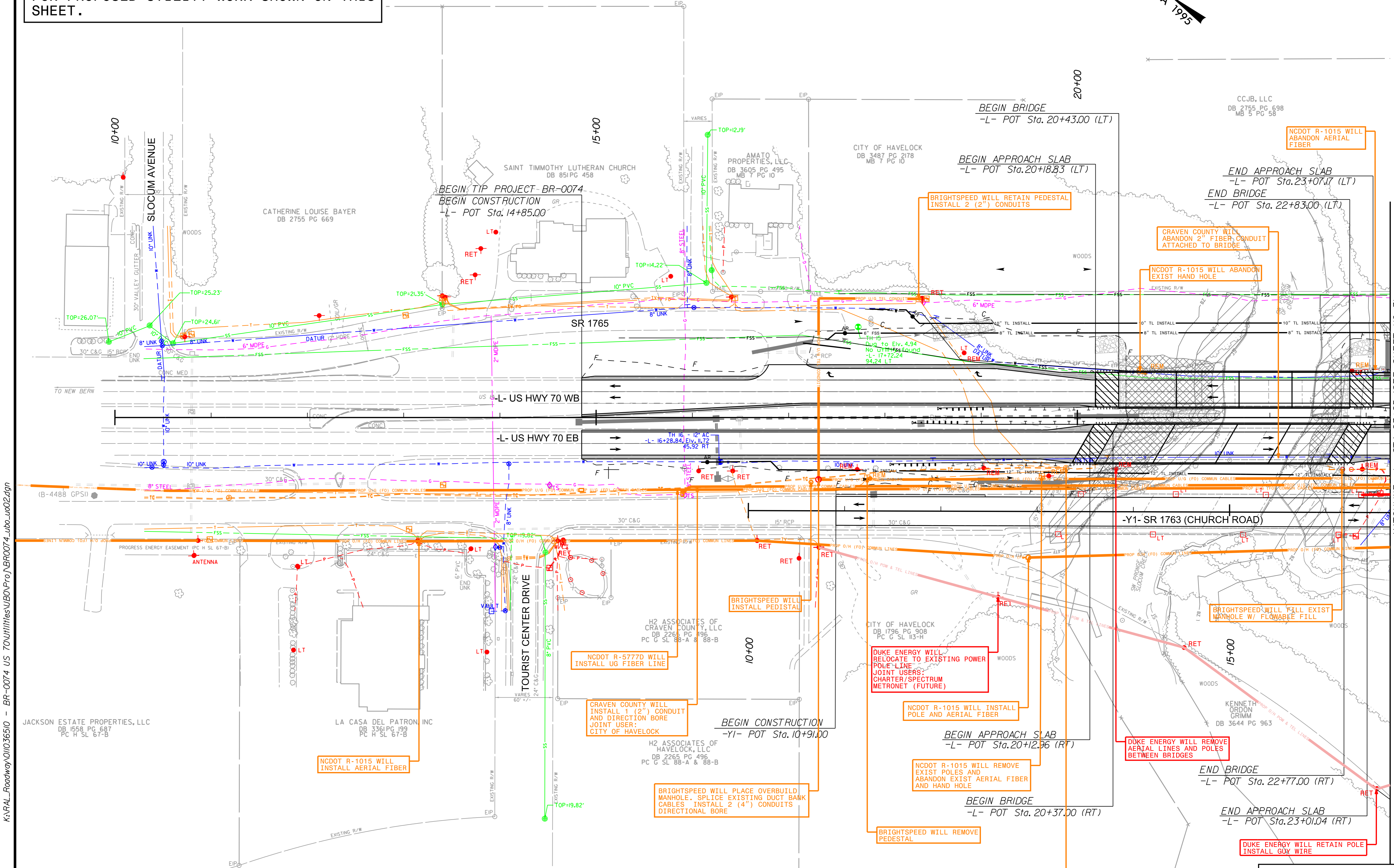
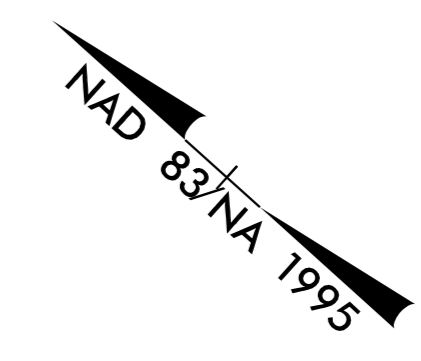

MATCHLINE -L- STA 23+25 (SEE SHEET UO-3)

K:\RAL\_Roadway\01036510 - BR-0074 US 70\Utilities\UBO\Pro\BR0074\_uo\_uo02.dgn 12/13/2022



NCDOT R-577D WILL INSTALL UG FIBER LINE

GRAVEN COUNTY WILL INSTALL 1 (2") CONDUIT AND DIRECTION BORE JOINT USER: CITY OF HAVELOCK

BRIGHTSPEED WILL PLACE OVERBUILD MANHOLE. SPLICE EXISTING DUCT BANK CABLES. INSTALL 2 (4") CONDUITS DIRECTIONAL BORE

DUKE ENERGY WILL RELOCATE TO EXISTING POWER POLE LINE JOINT USERS: CHARTER/SPECTRUM METRONET (FUTURE)

NCDOT R-1015 WILL INSTALL POLE AND AERIAL FIBER

NCDOT R-1015 WILL REMOVE EXIST POLES AND ABANDON EXIST AERIAL FIBER AND HAND HOLE

BRIGHTSPEED WILL REMOVE PEDESTAL

BRIGHTSPEED WILL FILL EXIST MANHOLE W/ FLOWABLE FILL

BRIGHTSPEED WILL RETAIN PEDESTAL INSTALL 2 (2") CONDUITS

GRAVEN COUNTY WILL ABANDON 2" FIBER CONDUIT ATTACHED TO BRIDGE

NCDOT R-1015 WILL ABANDON EXIST HAND HOLE

NCDOT R-1015 WILL ABANDON AERIAL FIBER

DUKE ENERGY WILL REMOVE AERIAL LINES AND POLES BETWEEN BRIDGES

DUKE ENERGY WILL RETAIN POLE INSTALL GUY WIRE



# UTILITIES BY OTHERS

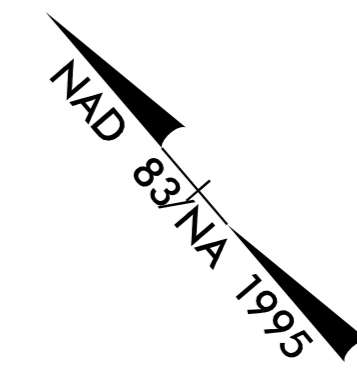

**NOTE:**  
ALL PROPOSED UTILITY WORK SHOWN ON THIS SHEET WILL BE DONE BY OTHERS. NO PAYMENT WILL BE MADE TO THE CONTRACTOR FOR PROPOSED UTILITY WORK SHOWN ON THIS SHEET.

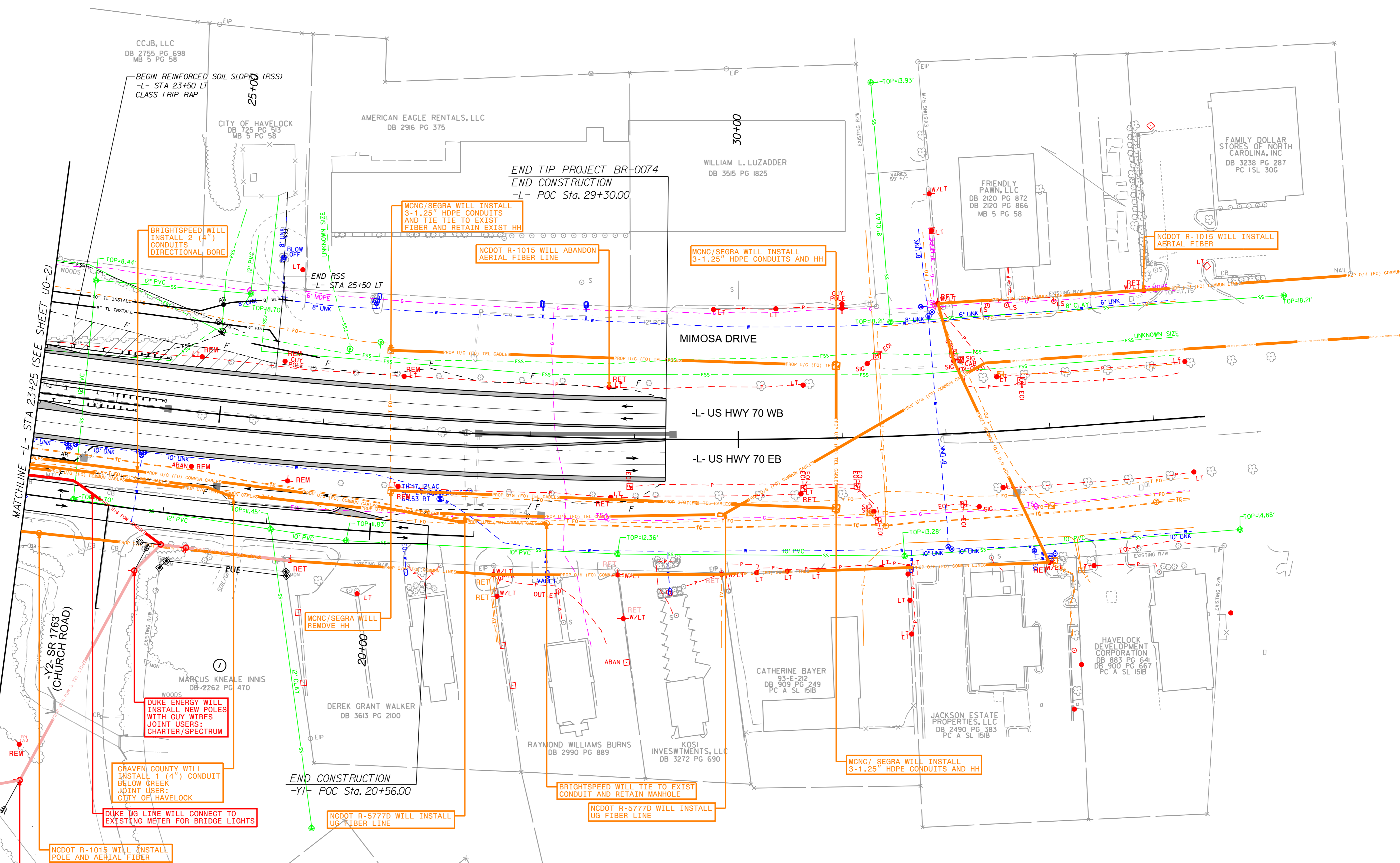

K:\RAL\_Roadway\01036510 - BR-0074 US 70\Utilities\UGA\Pro\BR0074\_UGA\_u03.dgn  
12/13/2022

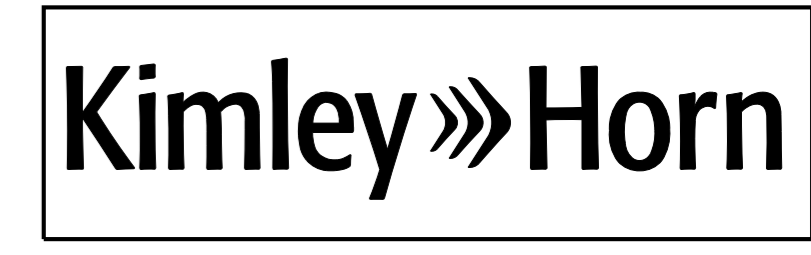



# UTILITIES BY OTHERS

**NOTE:**  
 ALL PROPOSED UTILITY WORK SHOWN ON THIS SHEET WILL BE DONE BY OTHERS. NO PAYMENT WILL BE MADE TO THE CONTRACTOR FOR PROPOSED UTILITY WORK SHOWN ON THIS SHEET.

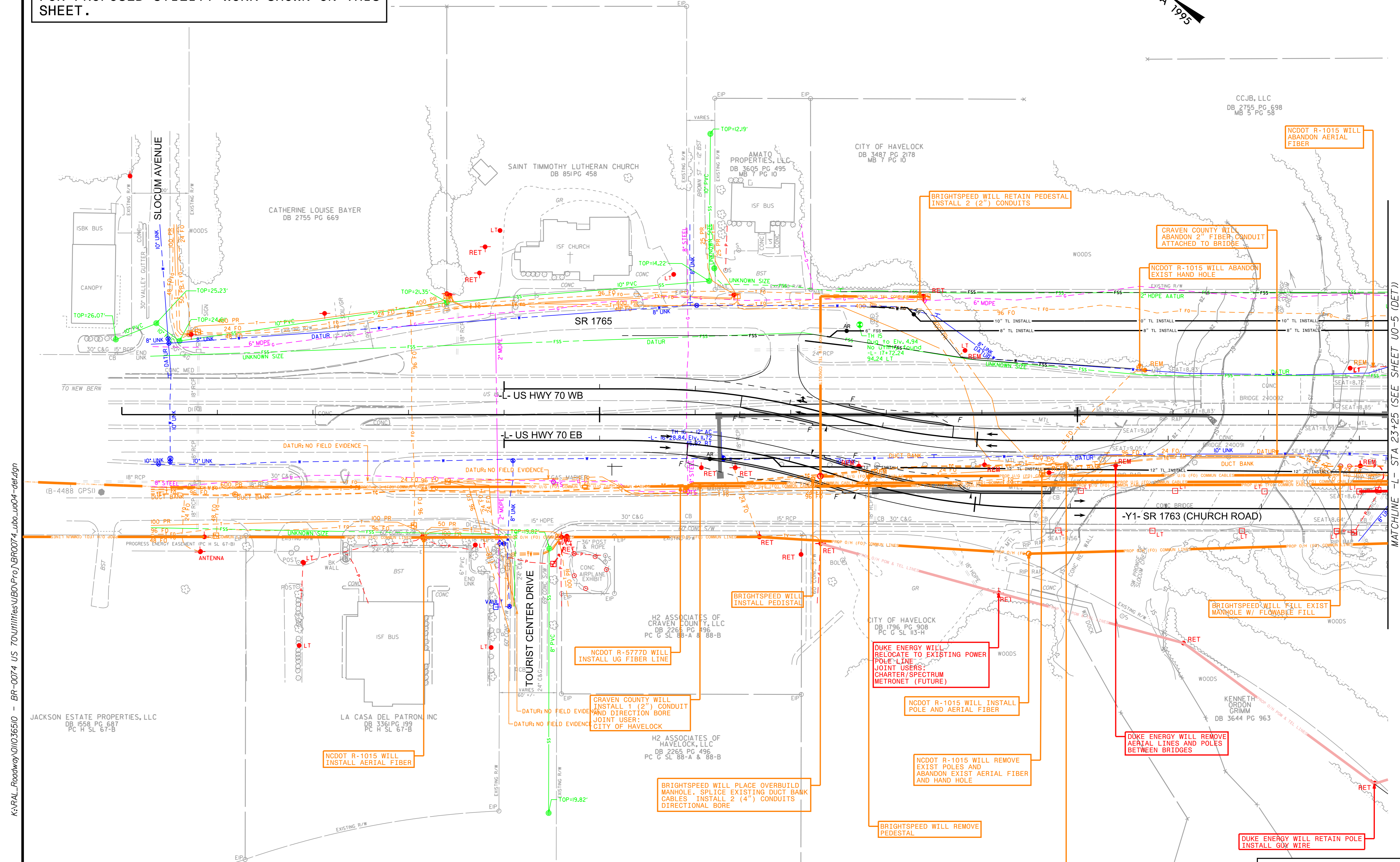
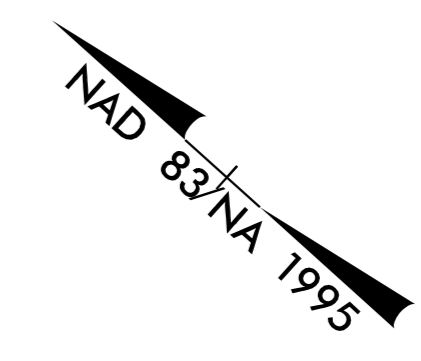

K:\RAL\_Roadway\01036510 - BR-0074 US TOUtilities\UBO\Pro\BR0074\_uo-04-del.dgn  
 12/13/2022

MATCHLINE -L- STA 23+25 (SEE SHEET UO-5 (DET))

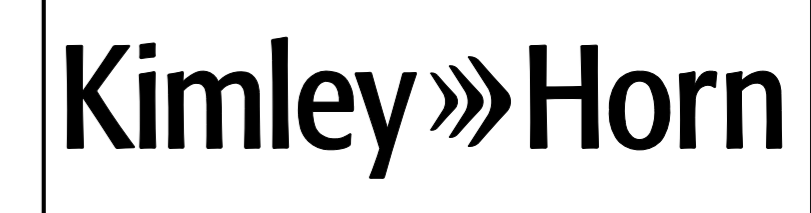



# UTILITIES BY OTHERS

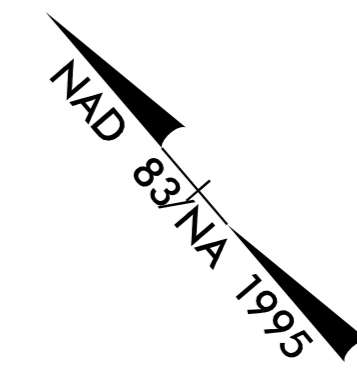

**NOTE:**  
ALL PROPOSED UTILITY WORK SHOWN ON THIS SHEET WILL BE DONE BY OTHERS. NO PAYMENT WILL BE MADE TO THE CONTRACTOR FOR PROPOSED UTILITY WORK SHOWN ON THIS SHEET.

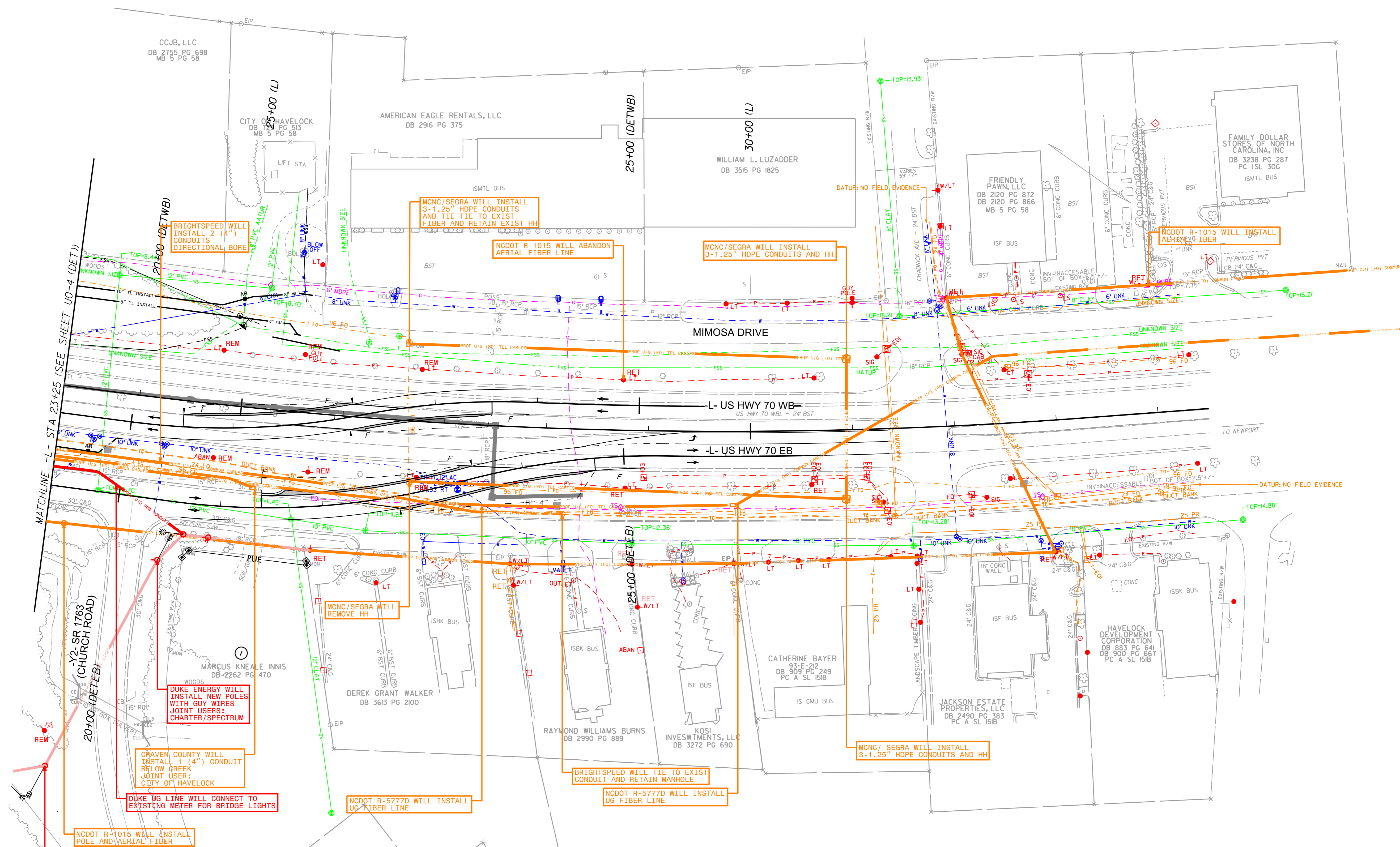

K:\RAL\_Roadway\01036510 - BR-0074 US 70\Utilities\UBA\Pro\BR0074\_UBA\_u05-det.dgn

12/13/2022

