

NORTH CAROLINA

Department of Transportation



TIP: R-5782BA

Curb Ramp Improvement Project

Ayden, Grifton, Winterville, Greenville

Heather Lane, PE
Contract: DB00564
WBS: 44912.3.24

2023

CURB RAMP AND EXISTING SIDEWALK WITH GRASS STRIP

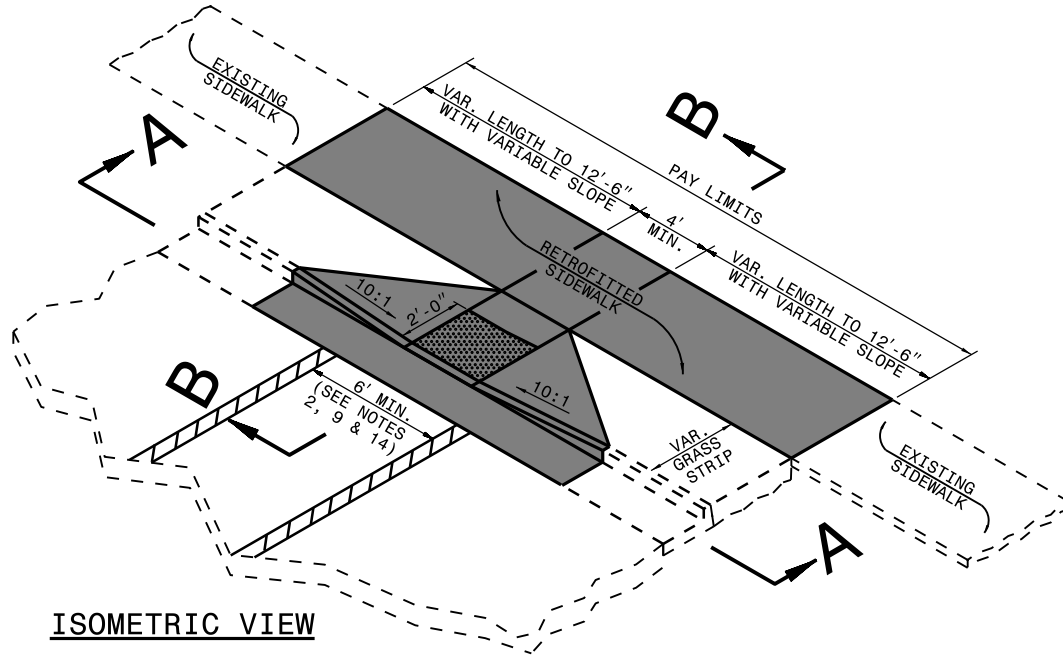

ISOMETRIC VIEW

PAY LIMITS OF CURB RAMP

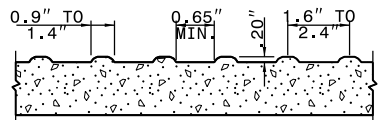
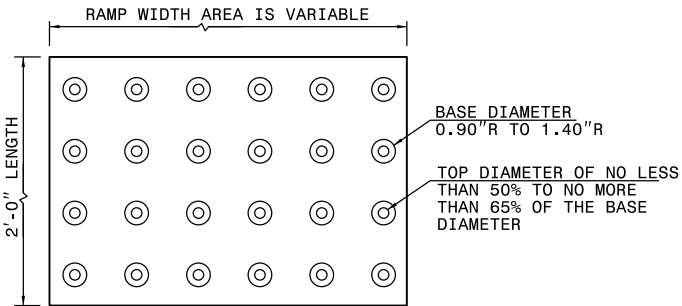

DETECTABLE WARNING DOMES

- NOTES:
1. PLACE DETECTABLE WARNING DOMES TO COVER 2'-0" LENGTH AND FULL WIDTH OF THE RAMP FLOOR AS SHOWN ON THE DETAILS.
 2. OBTAIN VISIBLE CONTRAST WITH ADJOINING SURFACE, EITHER LIGHT-ON-DARK, OR DARK-ON-LIGHT SEQUENCE COVERING THE ENTIRE RAMP.

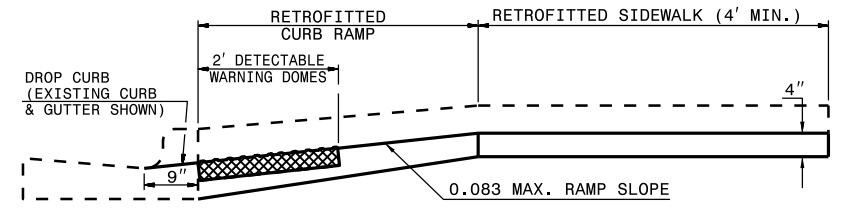

SECTION B-B

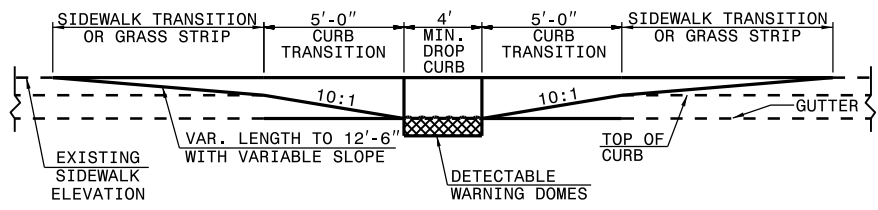

SECTION A-A

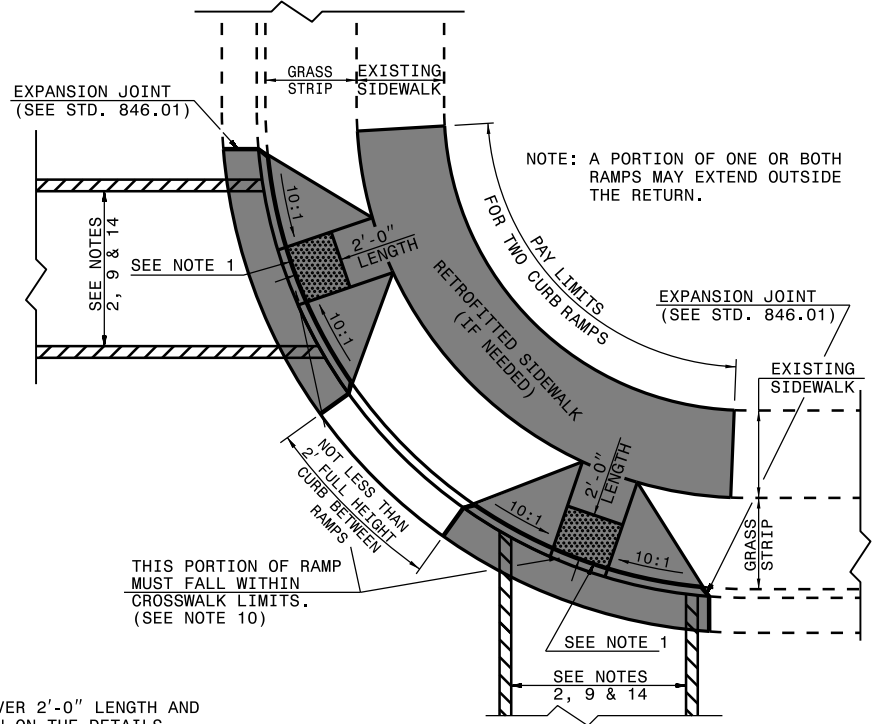

PLAN VIEW

DUAL RAMPS
ANY RADII
(40" MIN. FLOOR WIDTH)

CURB RAMPS AND EXISTING SIDEWALK ADJACENT TO CURB

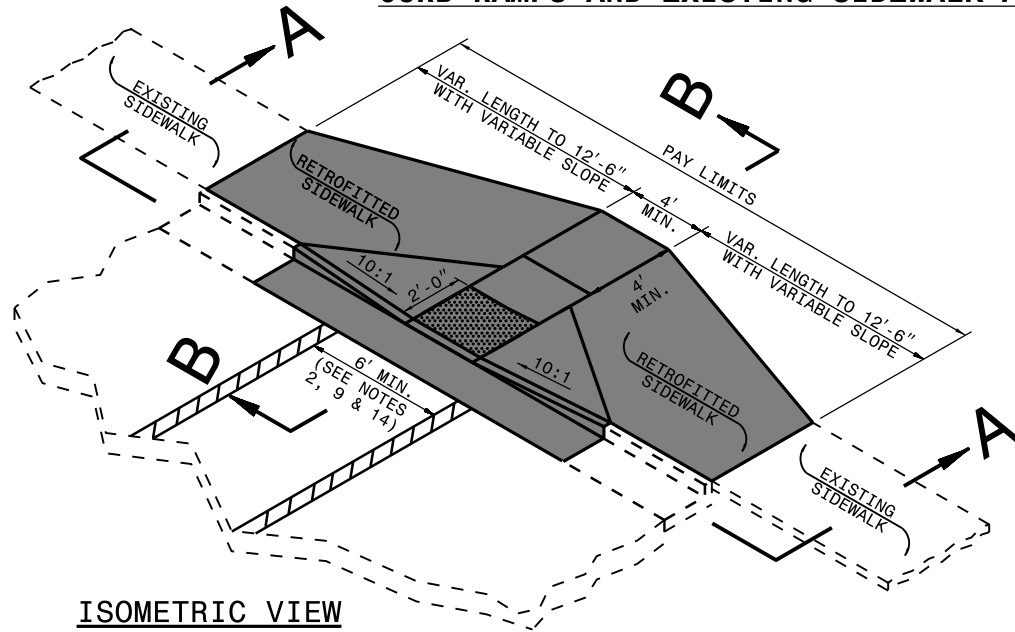

ISOMETRIC VIEW

PAY LIMITS OF CURB RAMP

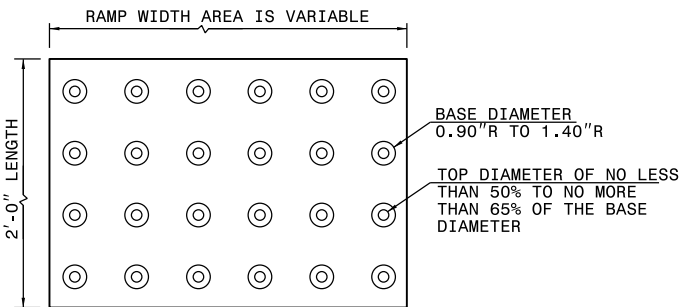

DETECTABLE WARNING DOMES

- NOTES:
1. PLACE DETECTABLE WARNING DOMES TO COVER 2'-0" LENGTH AND FULL WIDTH OF THE RAMP FLOOR AS SHOWN ON THE DETAILS.
 2. OBTAIN VISIBLE CONTRAST WITH ADJOINING SURFACE, EITHER LIGHT-ON-DARK, OR DARK-ON-LIGHT SEQUENCE COVERING THE ENTIRE RAMP.

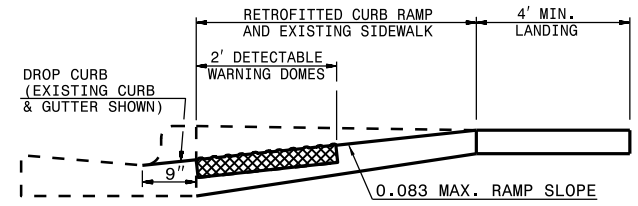

SECTION B-B

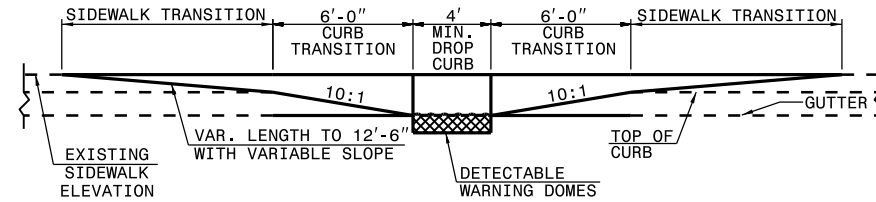

SECTION A-A

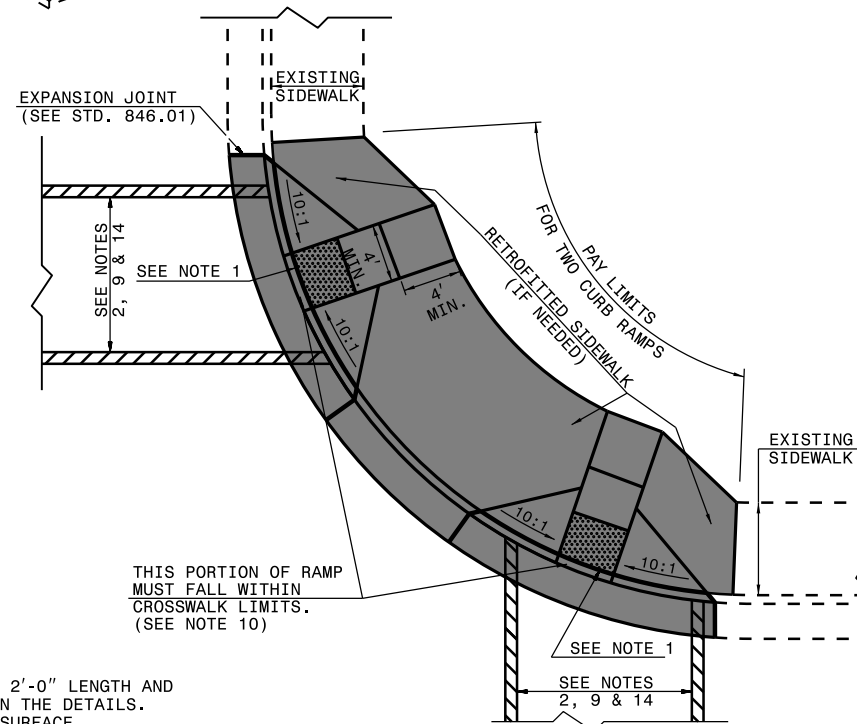

PLAN VIEW

DUAL RAMPS
ANY RADII
(40" MIN. FLOOR WIDTH)

RETROFITTING DETECTABLE WARNING DOMES ONTO EXISTING CURB RAMP

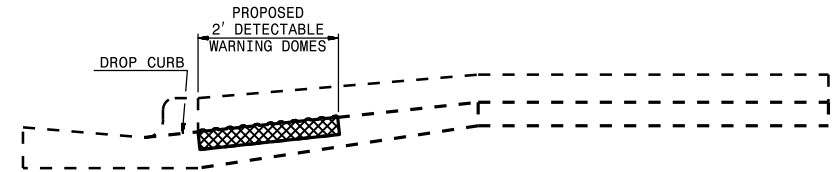
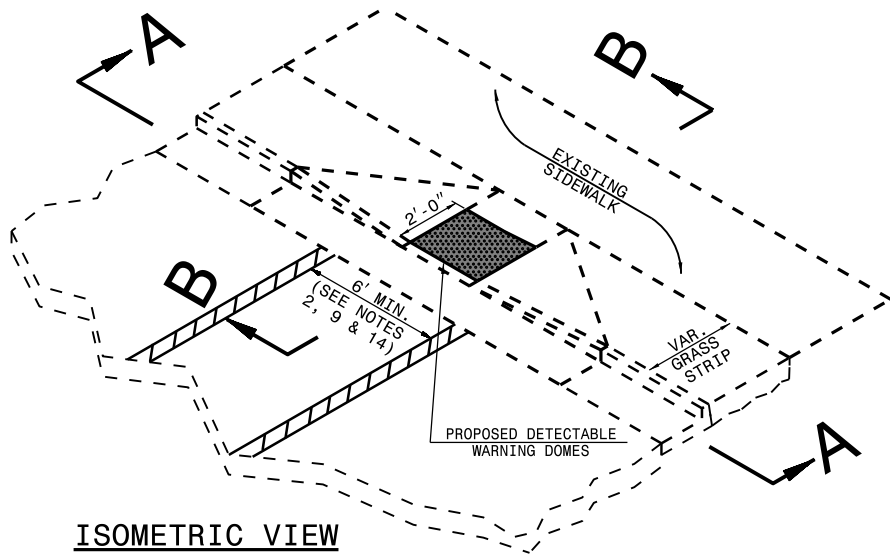

SECTION B-B

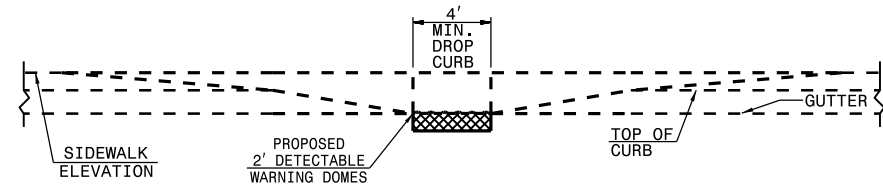

SECTION A-A

PAY LIMITS OF RETROFIT CURB RAMP

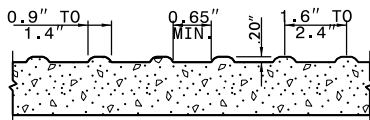
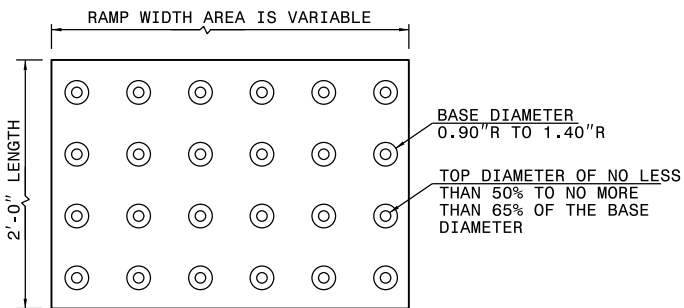

DETECTABLE WARNING DOMES

- NOTES:
1. PLACE DETECTABLE WARNING DOMES TO COVER 2'-0" LENGTH AND FULL WIDTH OF THE RAMP FLOOR AS SHOWN ON THE DETAILS.
 2. OBTAIN VISIBLE CONTRAST WITH ADJOINING SURFACE, EITHER LIGHT-ON-DARK, OR DARK-ON-LIGHT SEQUENCE COVERING THE ENTIRE RAMP.

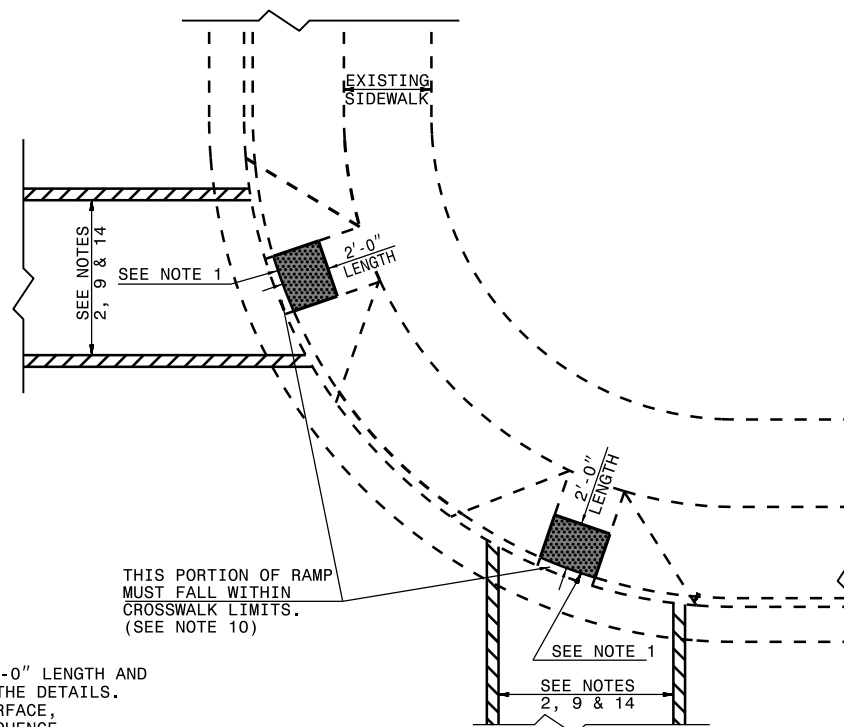

PLAN VIEW

DUAL RAMPS
ANY RADII
(40" MIN. FLOOR WIDTH)

ROADWAY STANDARD DRAWING FOR

CURB RAMP

EXISTING CURB AND GUTTER

1-18

STATE OF
NORTH CAROLINA
DEPT. OF TRANSPORTATION
DIVISION OF HIGHWAYS
RALEIGH, N.C.

CURB RAMPS AND EXISTING SIDEWALK

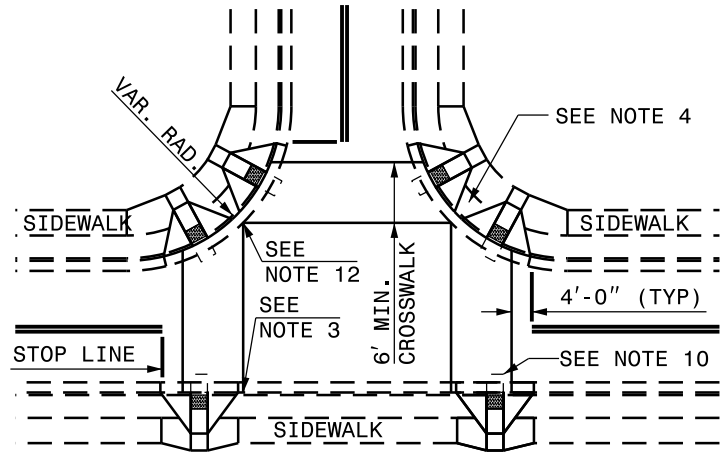

DETAIL SHOWING TYPICAL LOCATION OF CURB RAMPS, PEDESTRIAN CROSSWALKS AND STOP LINES FOR TEE INTERSECTIONS

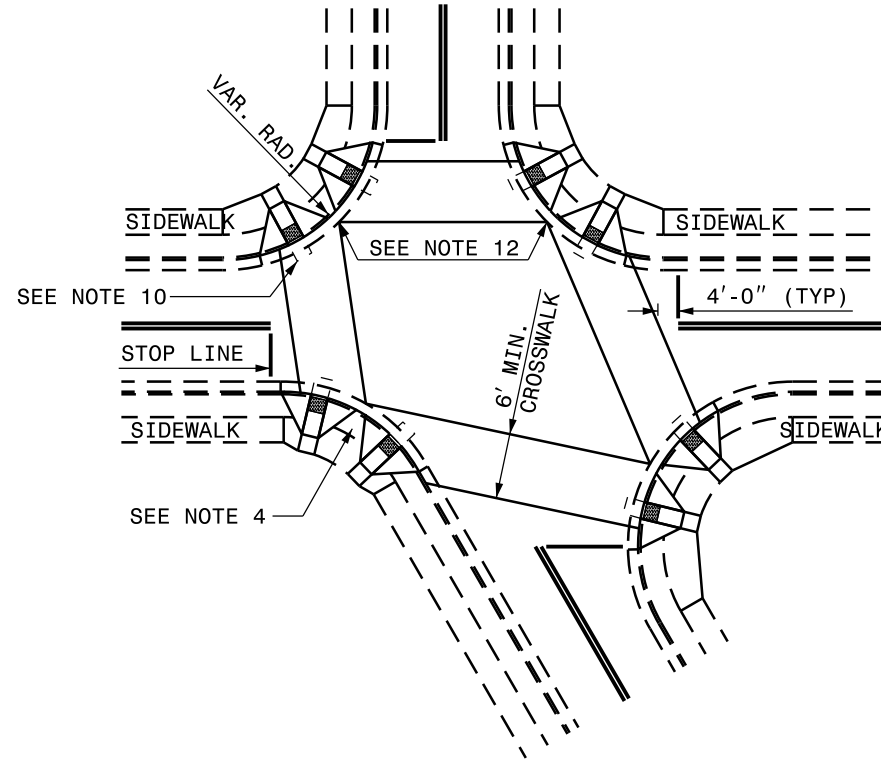

DETAIL SHOWING TYPICAL LOCATION OF CURB RAMPS, PEDESTRIAN CROSSWALKS AND STOP LINES

RESURFACING PROJECTS

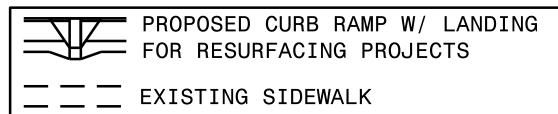

ALLOWABLE LOCATIONS
 DUAL RAMP RADII.....ANY

CURB RAMP AND EXISTING SIDEWALK

NOTES:

1. CONSTRUCT THE RAMP SURFACE TO BE STABLE, FIRM, AND SLIP RESISTANT. CONSTRUCT THE CURB RAMP TYPE AS SHOWN IN THE PAVEMENT MARKING PLANS OR AS DIRECTED BY THE ENGINEER.
2. LOCATE CURB RAMPS AND PLACE PEDESTRIAN CROSSWALK MARKINGS AS SHOWN IN THE PAVEMENT MARKING PLANS. WHEN FIELD ADJUSTMENTS REQUIRE MOVING CURB RAMPS OR MARKINGS AS SHOWN, CONTACT THE SIGNING AND DELINEATION UNIT OR LOCATE AS DIRECTED BY THE ENGINEER.
3. COORDINATE THE CURB RAMP AND THE PEDESTRIAN CROSSWALK MARKINGS SO A 4'x4' CLEAR SPACE AT THE BASE OF THE CURB RAMP WILL FALL WITHIN THE PEDESTRIAN CROSSWALK LINES.
4. SET BACK DISTANCE FROM INSIDE CROSSWALK MARKING TO NEAREST EDGE OF TRAVEL LANE IS 4' MINIMUM.
5. REFER TO THE PAVEMENT MARKING PLANS FOR STOP BAR LOCATIONS AT SIGNALIZED INTERSECTIONS. IF A PAVEMENT MARKING PLAN IS NOT PROVIDED, CONTACT THE SIGNAL DESIGN SECTION FOR THE STOP BAR LOCATIONS OR LOCATE AS DIRECTED BY THE ENGINEER.
6. TERMINATE PARKING A MINIMUM OF 20' BACK OF A PEDESTRIAN CROSSWALK.
7. CONSTRUCT CURB RAMPS A MINIMUM OF 4' WIDE.
8. CONSTRUCT THE RUNNING SLOPE OF THE RAMP 8.33% MAXIMUM.
9. ALLOWABLE CROSS SLOPE ON SIDEWALKS AND CURB RAMPS WILL BE 2% MAXIMUM.
10. CONSTRUCT THE SIDE FLARE SLOPE A MAXIMUM OF 10% MEASURED ALONG THE CURB LINE.
11. CONSTRUCT THE COUNTER SLOPE OF THE GUTTER OR STREET AT THE BASE OF THE CURB RAMP A MAXIMUM OF 5% AND MAINTAIN A SMOOTH TRANSITION.
12. CONSTRUCT LANDINGS FOR SIDEWALK A MINIMUM OF 4'x4' WITH A MAXIMUM SLOPE OF 2% IN ANY DIRECTION. CONSTRUCT LANDINGS FOR MEDIAN ISLANDS A MINIMUM OF 5'x5' WITH A MAXIMUM SLOPE OF 2% IN ANY DIRECTION.
13. TO USE A MEDIAN ISLAND AS A PEDESTRIAN REFUGE AREA, MEDIAN ISLANDS WILL BE A MINIMUM OF 6' WIDE. CONSTRUCT MEDIAN ISLANDS TO PROVIDE PASSAGE OVER OR THROUGH THE ISLAND.
14. SMALL CHANNELIZATION ISLANDS THAT CAN NOT PROVIDE A 5'x5' LANDING AT THE TOP OF A RAMPS, WILL BE CUT THROUGH LEVEL WITH THE SURFACE STREET.
15. CURB RAMPS WITH RETURNED CURBS MAY BE USED ONLY WHERE PEDESTRIANS WOULD NOT NORMALLY WALK ACROSS THE RAMP. THE ADJACENT SURFACE IS PLANTING OR OTHER NON-WALKING SURFACE OR THE SIDE APPROACH IS SUBSTANTIALLY OBSTRUCTED.
16. PLACE A 1/2" EXPANSION JOINT WHERE THE CONCRETE CURB RAMP JOINS THE CURB AS SHOWN IN ROADWAY STANDARD DRAWING 848.01
17. PLACE ALL PEDESTRIAN PUSH BUTTON ACTUATORS AND CROSSING SIGNALS AS SHOWN IN THE PLANS OR AS SHOWN IN THE MUTCD.
18. CURB RAMPS THROUGH MEDIAN ISLANDS, SINGLE RAMPS AT DUAL CROSSWALKS OR LIMITED R/W SITUATIONS, WILL BE HANDLED BY SPECIAL DETAILS. CONTACT THE CONTRACT STANDARDS AND DEVELOPMENT UNIT FOR THE DETAILS OR FOR A SPECIAL DESIGN.

1-18

ROADWAY STANDARD DRAWING FOR

CURB RAMP

EXISTING CURB AND GUTTER

STATE OF

NORTH CAROLINA

DEPT. OF TRANSPORTATION

DIVISION OF HIGHWAYS
RALEIGH, N.C.

SHEET 5 OF 5

848.06

5/14/99

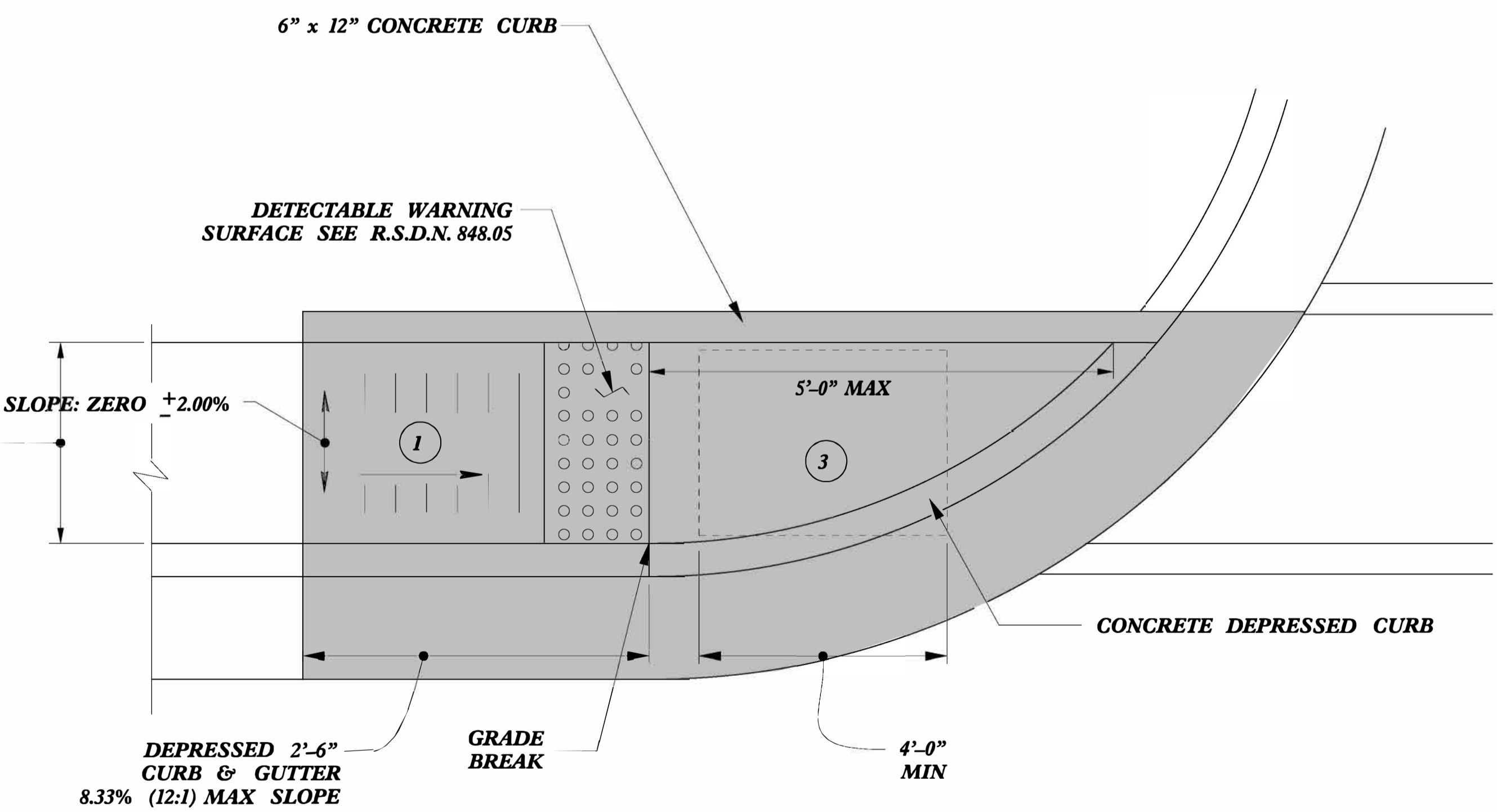
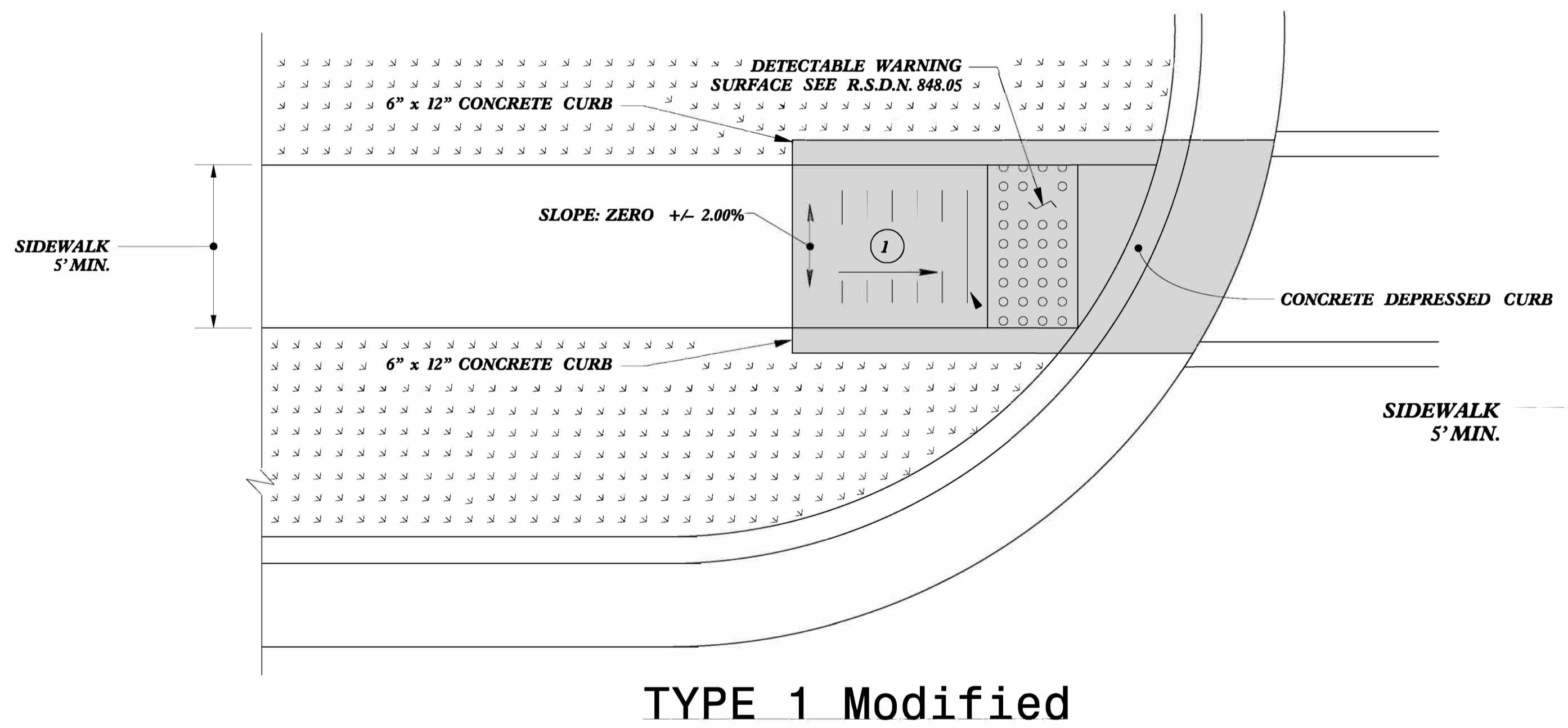
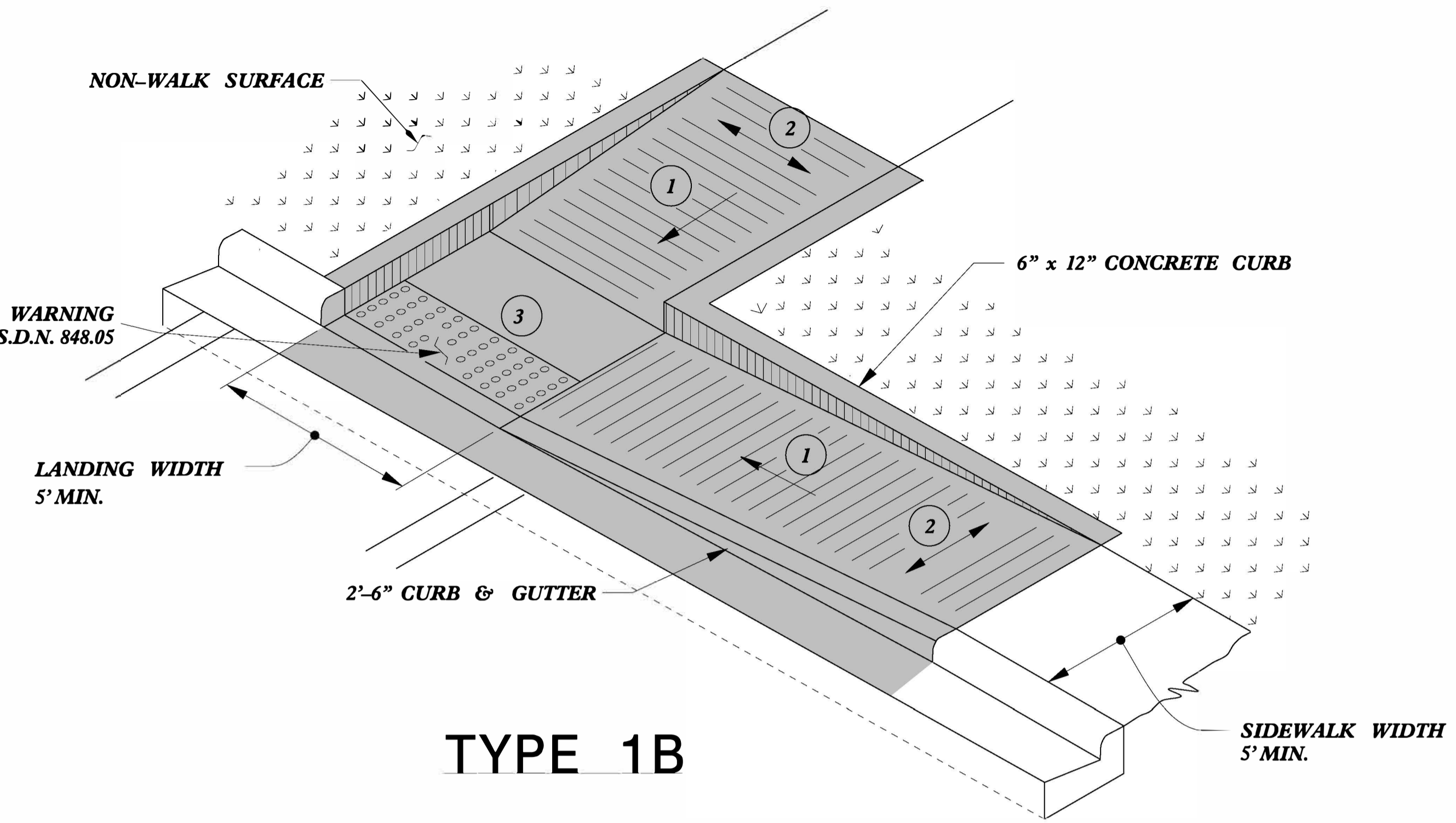
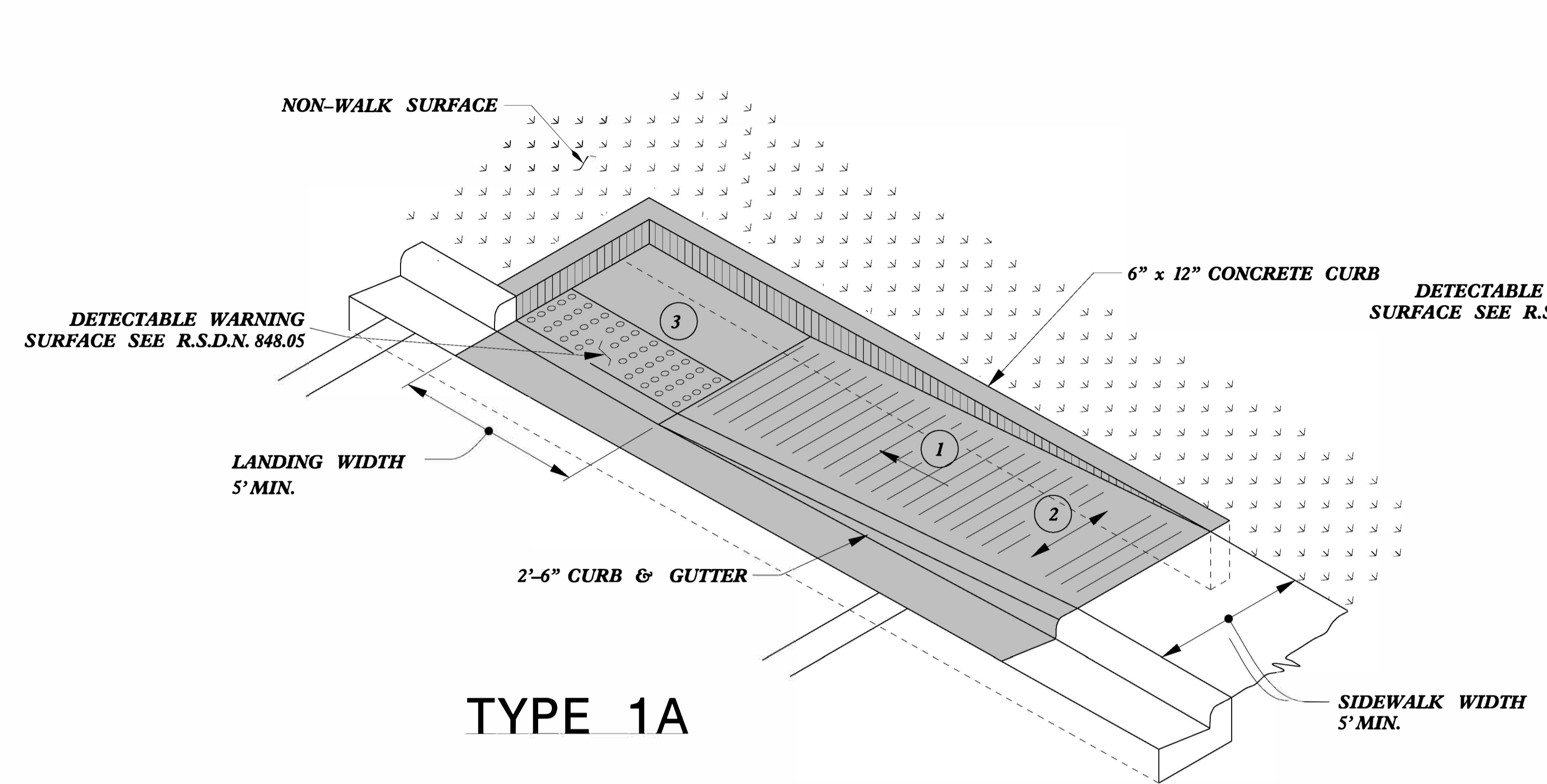

- 1 8.33% (12:1) MAX RAMP SLOPE
- 2 CROSS SLOPE: 2.00%
- 3 CURB RAMPS REQUIRE A (4'-0") MINIMUM LANDING WITH A MAXIMUM CROSS SLOPE AND LONGITUDINAL SLOPE OF 2.00% WHERE PEDESTRIANS PERFORM TURNING MANEUVERS. SLOPE TO DRAIN TO CURB.



PAY LIMITS FOR 1 CURB RAMP

REFER TO ROADWAY STANDARD DRAWING NUMBER 848.05 SHEET 3 OF 3 FOR ALL RAMP NOTES

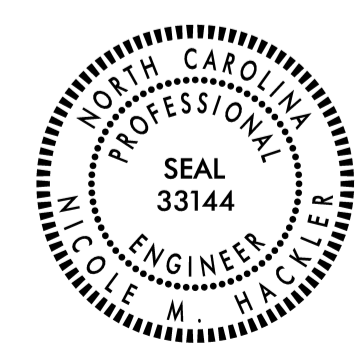

DOCUMENT NOT CONSIDERED FINAL UNLESS ALL SIGNATURES COMPLETED

CONTRACT STANDARDS AND DEVELOPMENT UNIT
Office 919-707-6950 FAX 919-250-4119

CURB RAMPS
Directional Ramps

ORIGINAL BY: J.S. HOWERTON DATE: 7/7/11
MODIFIED BY: DATE:
CHECKED BY: DATE:
FILE SPEC: stds/2012CurbRamp/CurbRampDetails.dgn

C:\TEMP\6666\DWG\848.05\848.05_CURB_RAMPS.dwg
 PLOT DATE: 7/7/11 10:00 AM
 PLOT BY: J.S. HOWERTON

5/14/99

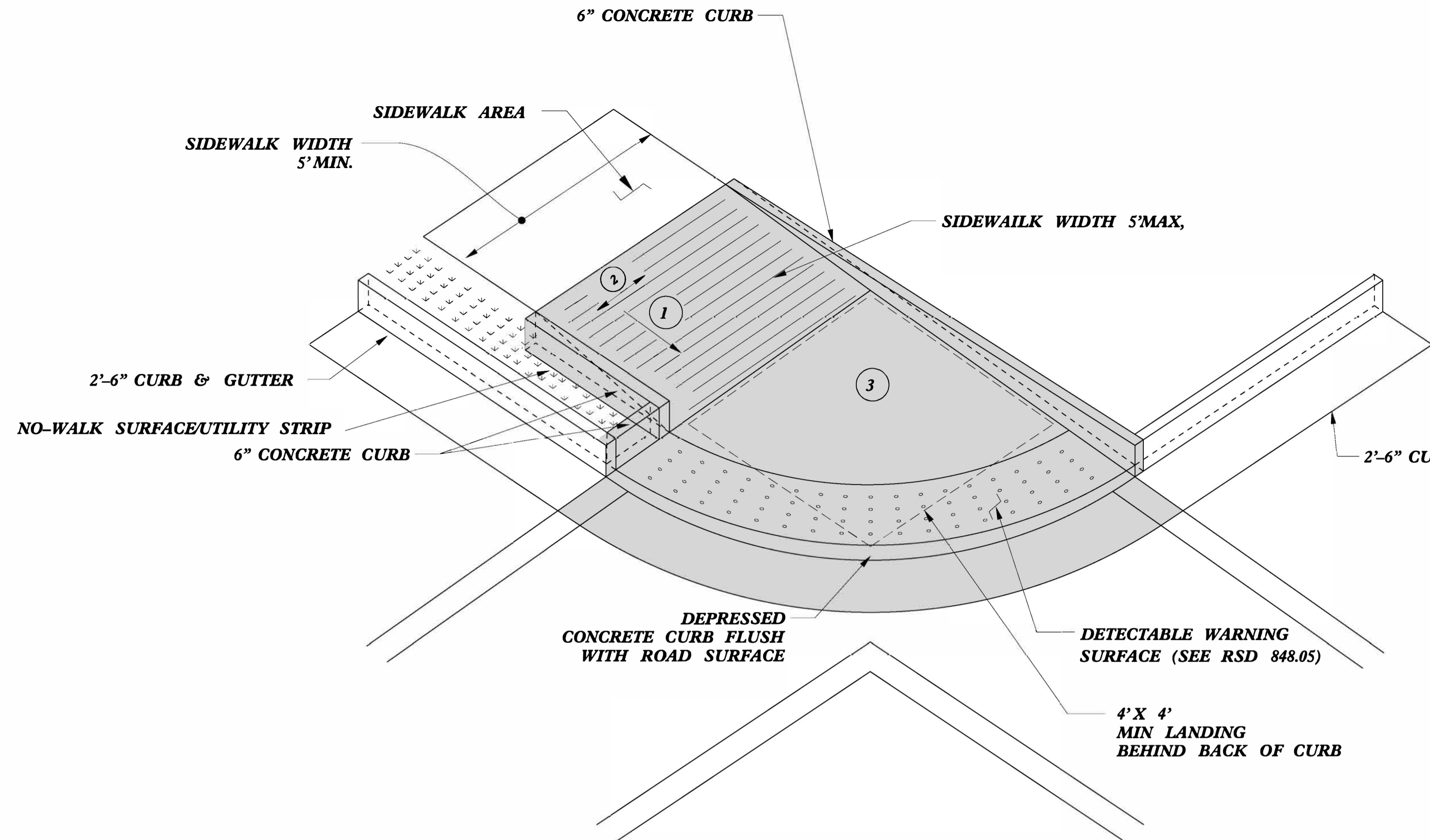

TYPE 2A MOD

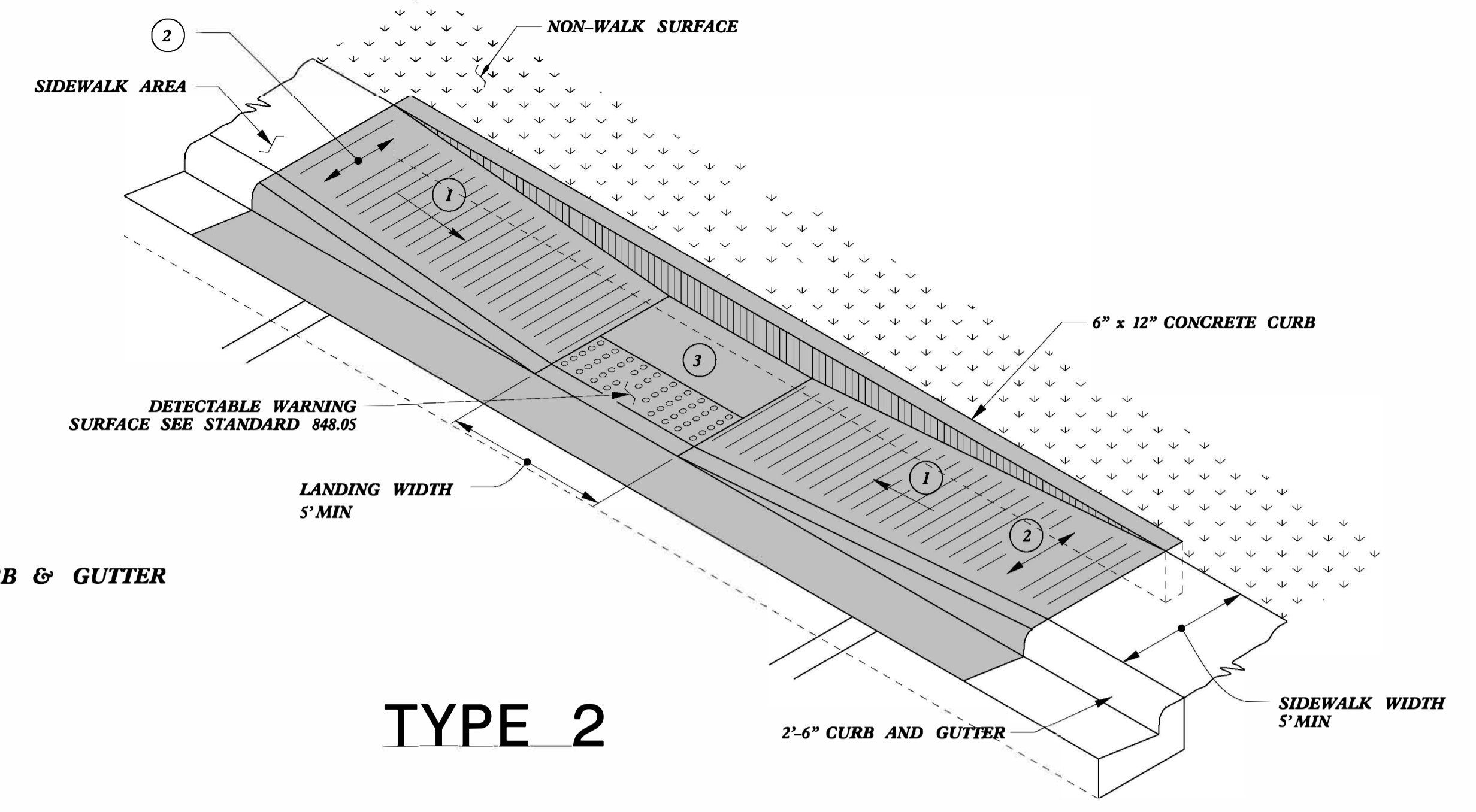

TYPE 2

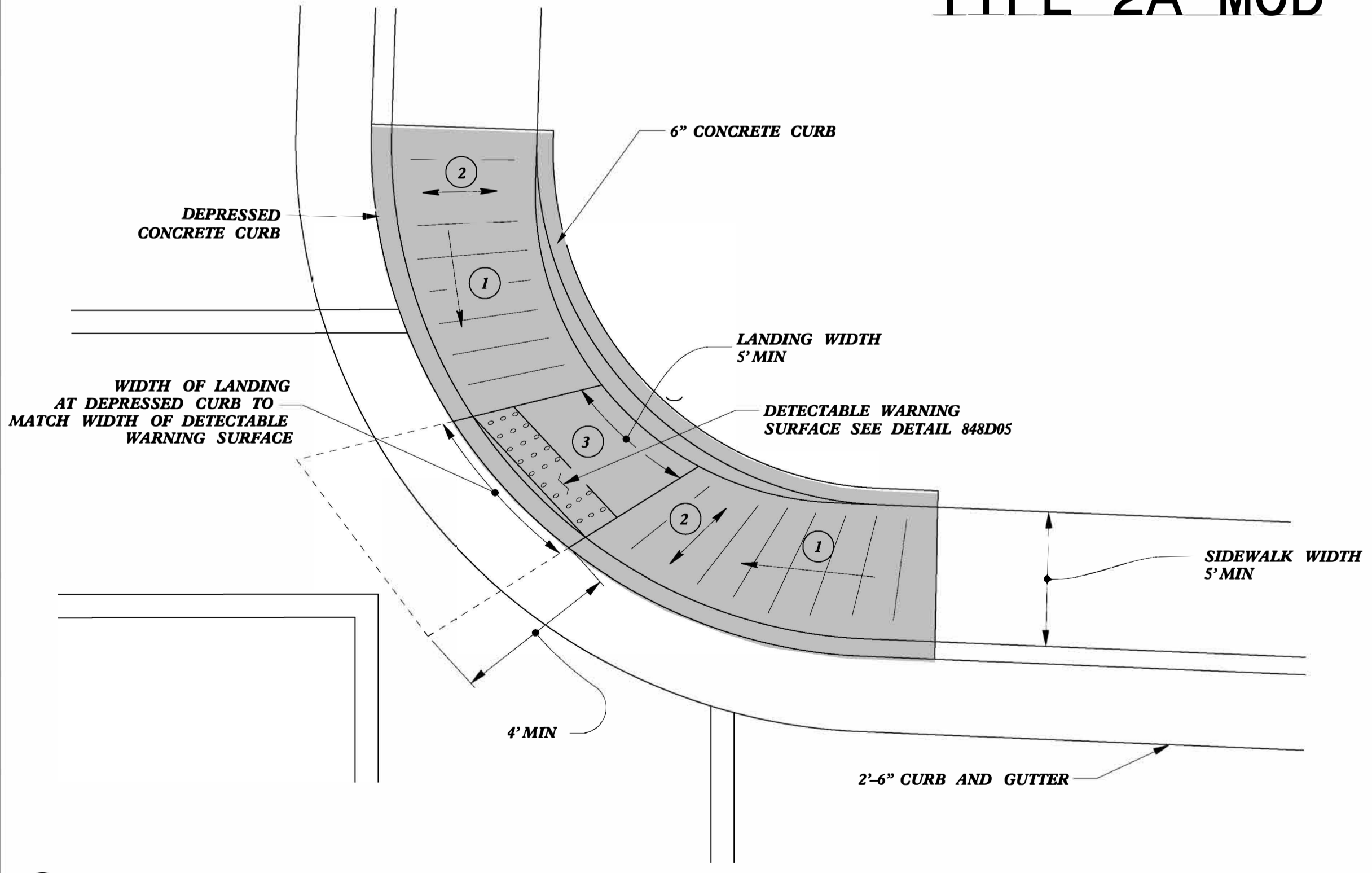

TYPE 2B

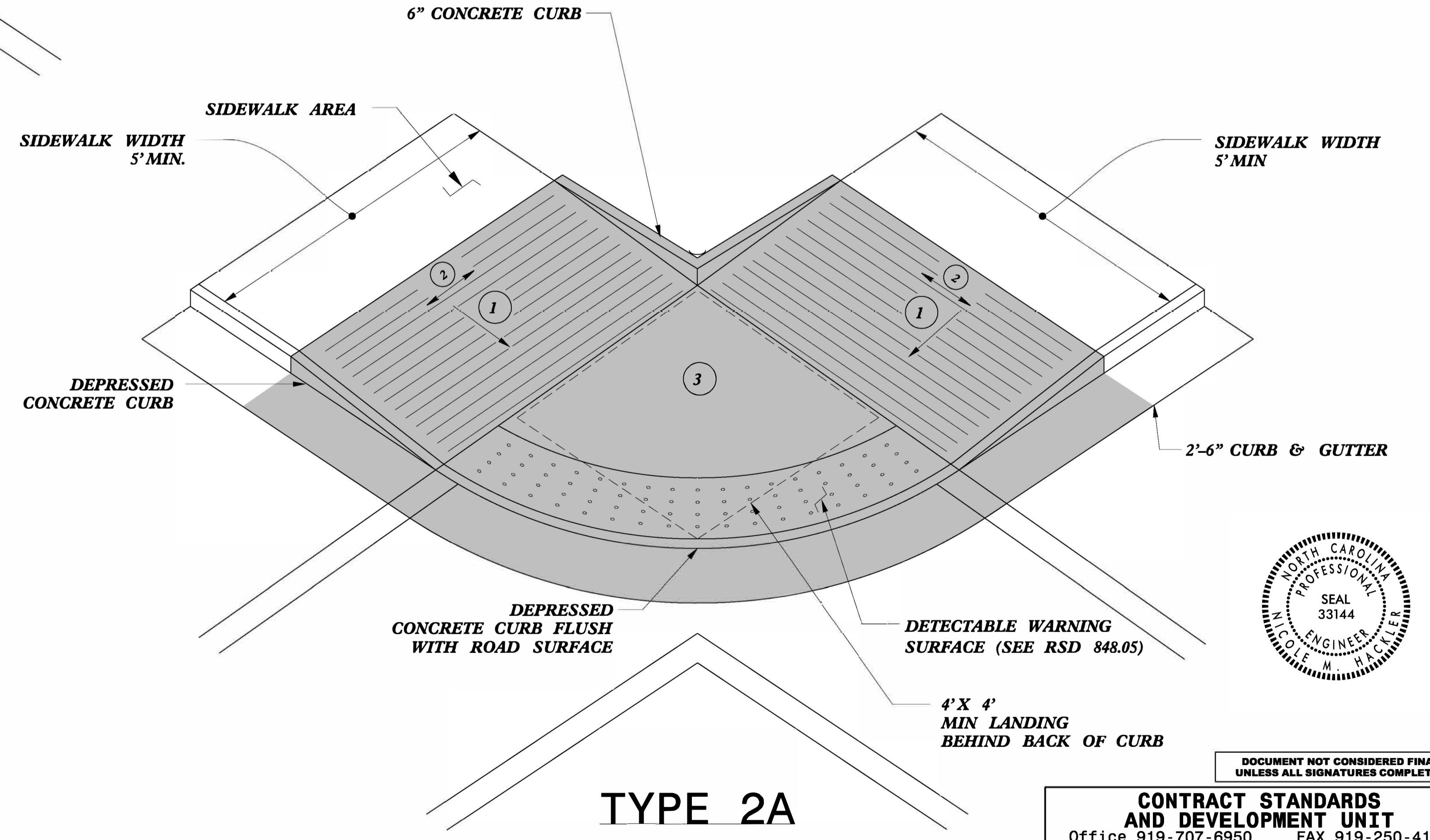

TYPE 2A

- 1 8.33% (12:1) MAX RAMP SLOPE
- 2 CROSS SLOPE: 2.00%
- 3 CURB RAMPS REQUIRE A (4'-0") MINIMUM LANDING WITH A MAXIMUM CROSS SLOPE AND LONGITUDINAL SLOPE OF 2.00% WHERE PEDESTRIANS PERFORM TURNING MANEUVERS. SLOPE TO DRAIN TO CURB.

PAY LIMITS FOR 1 CURB RAMP

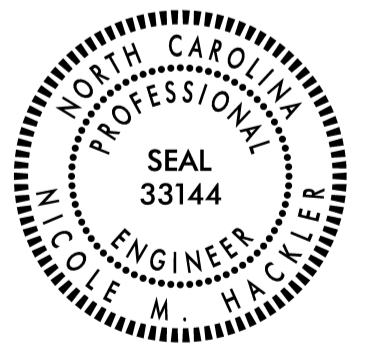

DOCUMENT NOT CONSIDERED FINAL UNLESS ALL SIGNATURES COMPLETED

CONTRACT STANDARDS AND DEVELOPMENT UNIT
Office 919-707-6950 FAX 919-250-4119

CURB RAMPS

ORIGINAL BY: J.S. HOWERTON DATE: 7/7/11
 MODIFIED BY: DATE:
 CHECKED BY: DATE:
 FILE SPEC. stds/2012CurbRamp/CurbRampDetails.dgn

PAY LIMITS FOR 1 CURB RAMP

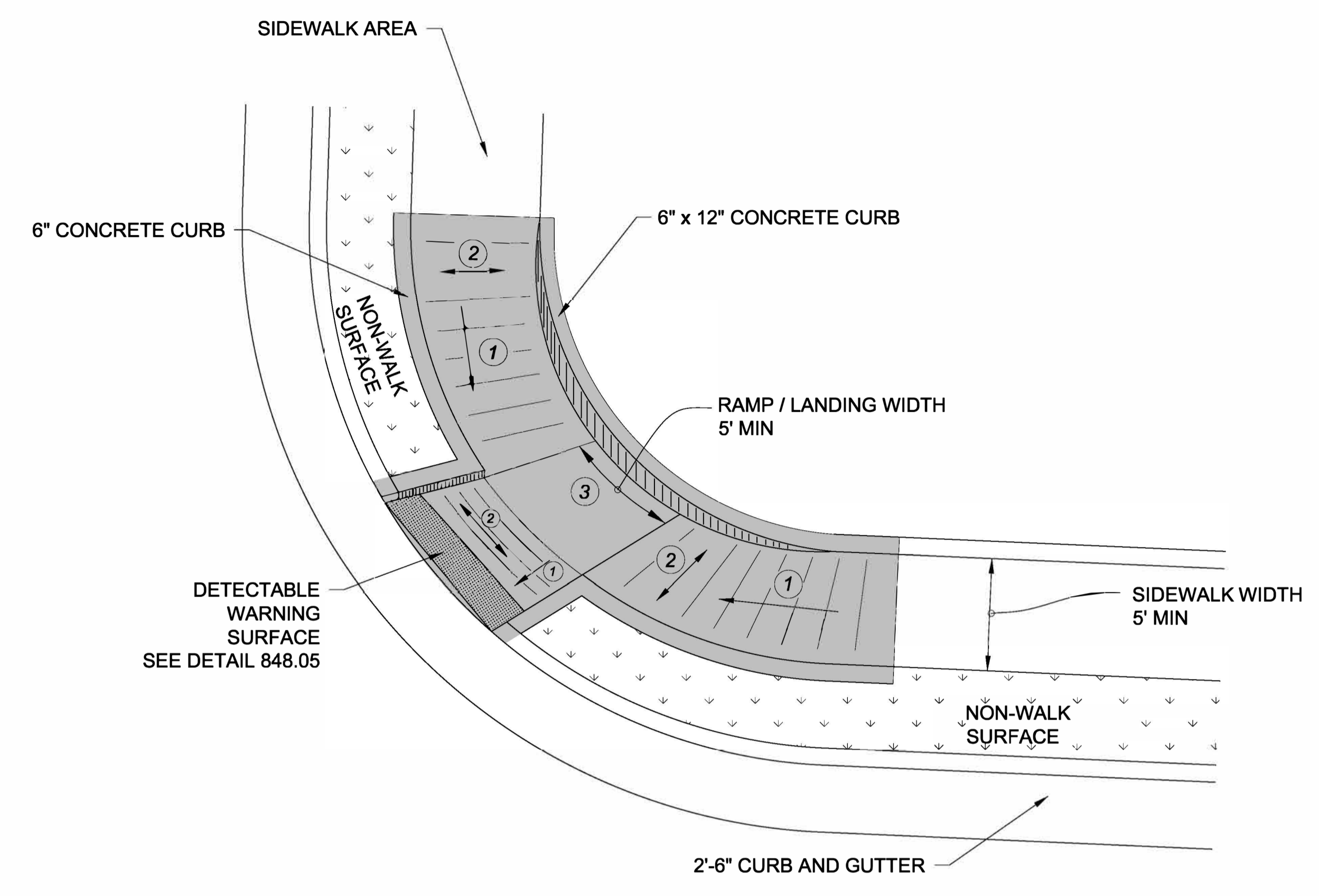

**TYPE 3 MODIFIED
INSTALLATION IN A RADIUS**

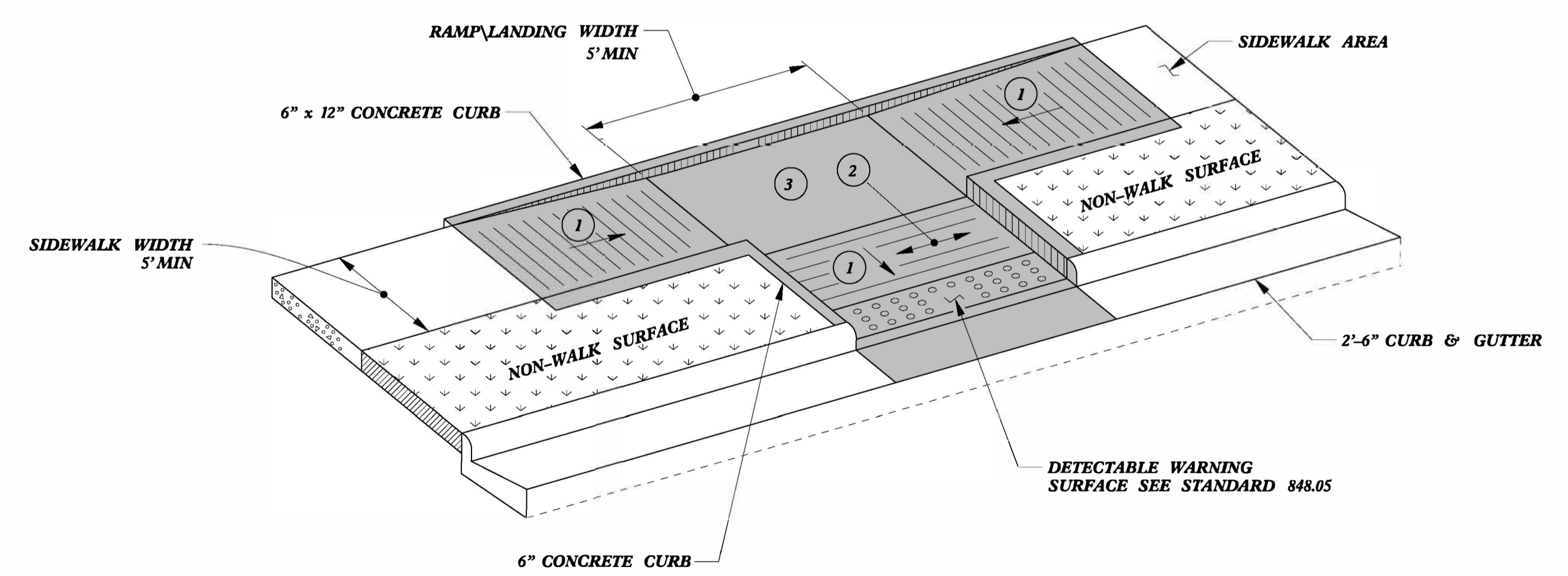

TYPE 3

- 1 8.33% (12:1) MAX RAMP SLOPE
- 2 CROSS SLOPE: 2.00%
- 3 CURB RAMPS REQUIRE A (4'-0") MINIMUM LANDING WITH A MAXIMUM CROSS SLOPE AND LONGITUDINAL SLOPE OF 2.00% WHERE PEDESTRIANS PERFORM TURNING MANEUVERS. SLOPE TO DRAIN TO CURB.

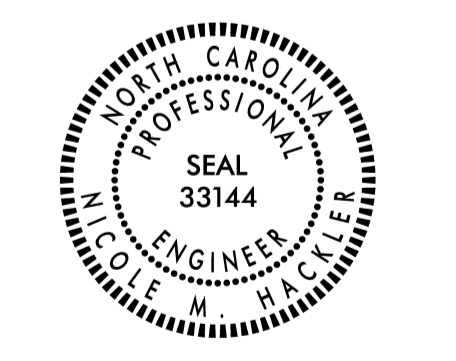

DOCUMENT NOT CONSIDERED FINAL
UNLESS ALL SIGNATURES COMPLETED

CONTRACT STANDARDS AND DEVELOPMENT UNIT	
Office 919-707-6950	FAX 919-250-4119
CURB RAMPS	
ORIGINAL BY: J.S. HOWERTON	DATE: 7/7/11
MODIFIED BY:	DATE:
CHECKED BY:	DATE:
FILE SPEC. :stds/2012CurbRamp/CurbRampDetails.dgn	

5/14/99
C:\P\2012\STDS\2012CurbRamp\CurbRampDetails.dgn

5/14/99

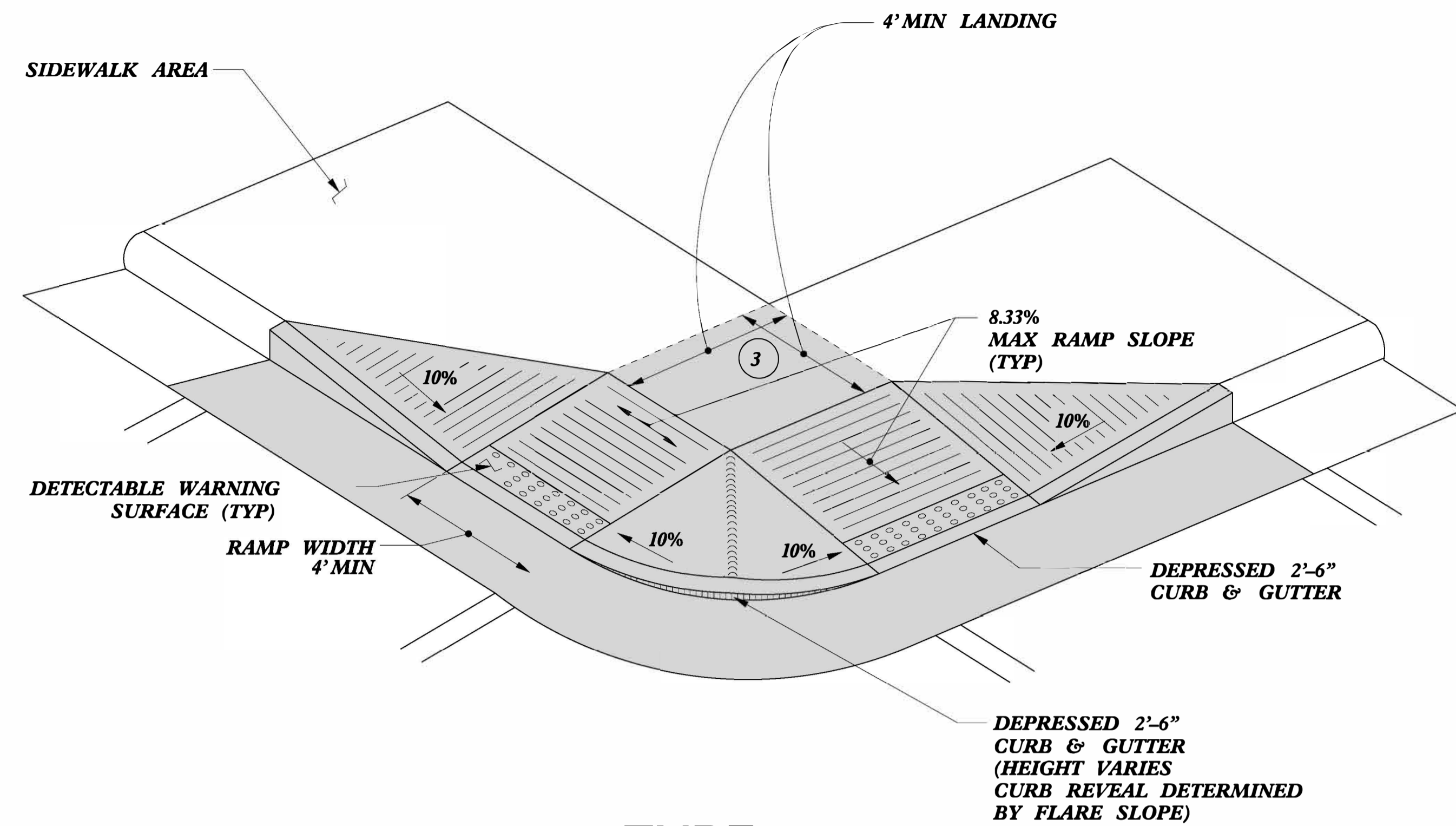

TYPE 4

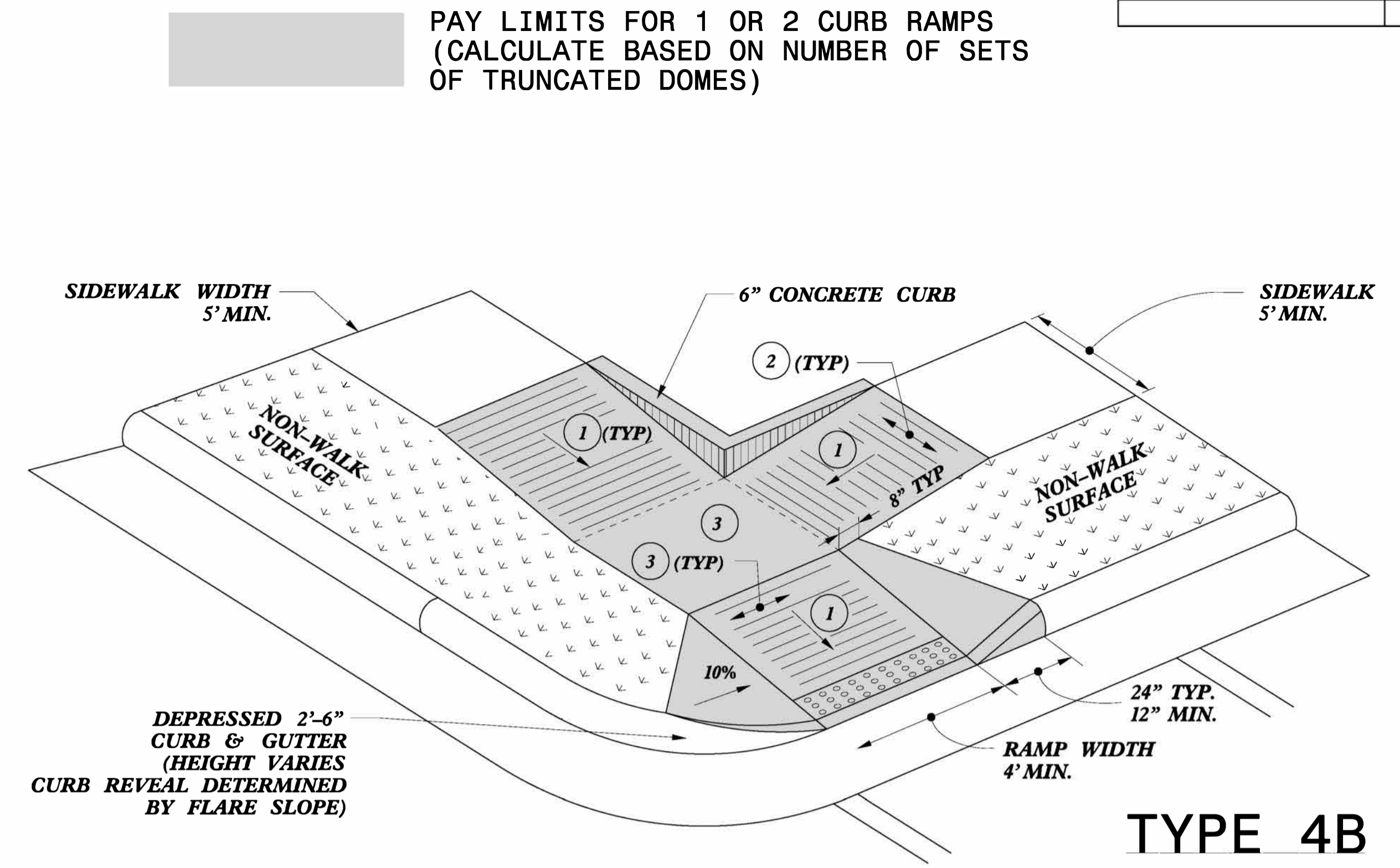

TYPE 4B

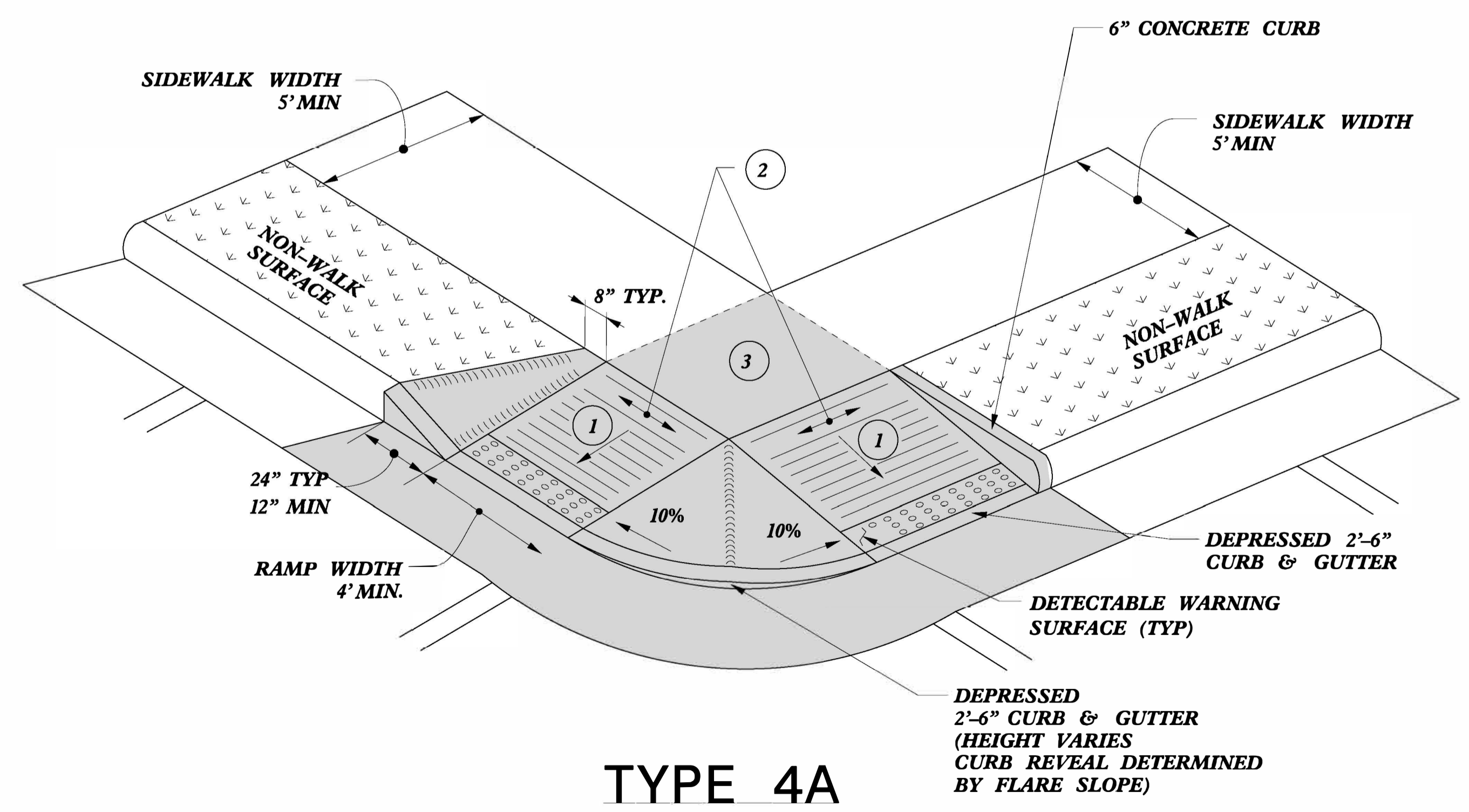

TYPE 4A

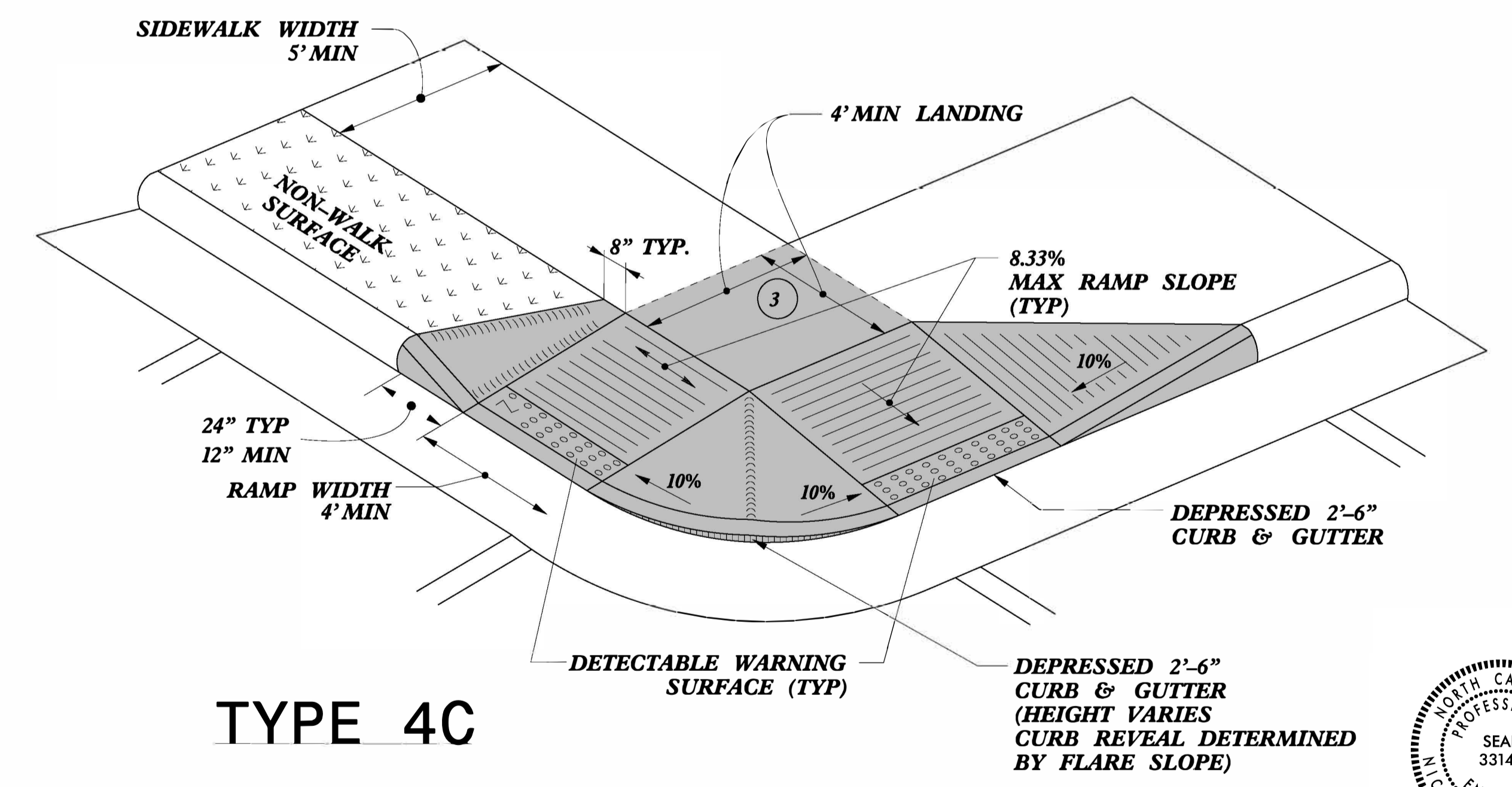

TYPE 4C

- 1 8.33% (12:1) MAX RAMP SLOPE
- 2 CROSS SLOPE: 2.00%
- 3 CURB RAMPS REQUIRE A (4'-0") MINIMUM LANDING WITH A MAXIMUM CROSS SLOPE AND LONGITUDINAL SLOPE OF 2.00% WHERE PEDESTRIANS PERFORM TURNING MANEUVERS. SLOPE TO DRAIN TO CURB.



DOCUMENT NOT CONSIDERED FINAL UNLESS ALL SIGNATURES COMPLETED

CONTRACT STANDARDS AND DEVELOPMENT UNIT
Office 919-707-6950 FAX 919-250-4119

CURB RAMPS

ORIGINAL BY: J.S. HOWERTON DATE: 7/7/11
 MODIFIED BY: DATE:
 CHECKED BY: DATE:
 FILE SPEC. stds/2012CurbRamp/CurbRampDetails.dgn

REFER TO ROADWAY STANDARD DRAWING NUMBER 848.05 SHEET 3 OF 3 FOR ALL RAMP NOTES

5/14/99

5/14/99

PAY LIMITS FOR 1 OR 2 CURB RAMPS
(CALCULATE BASED ON NUMBER OF SETS
OF TRUNCATED DOMES)

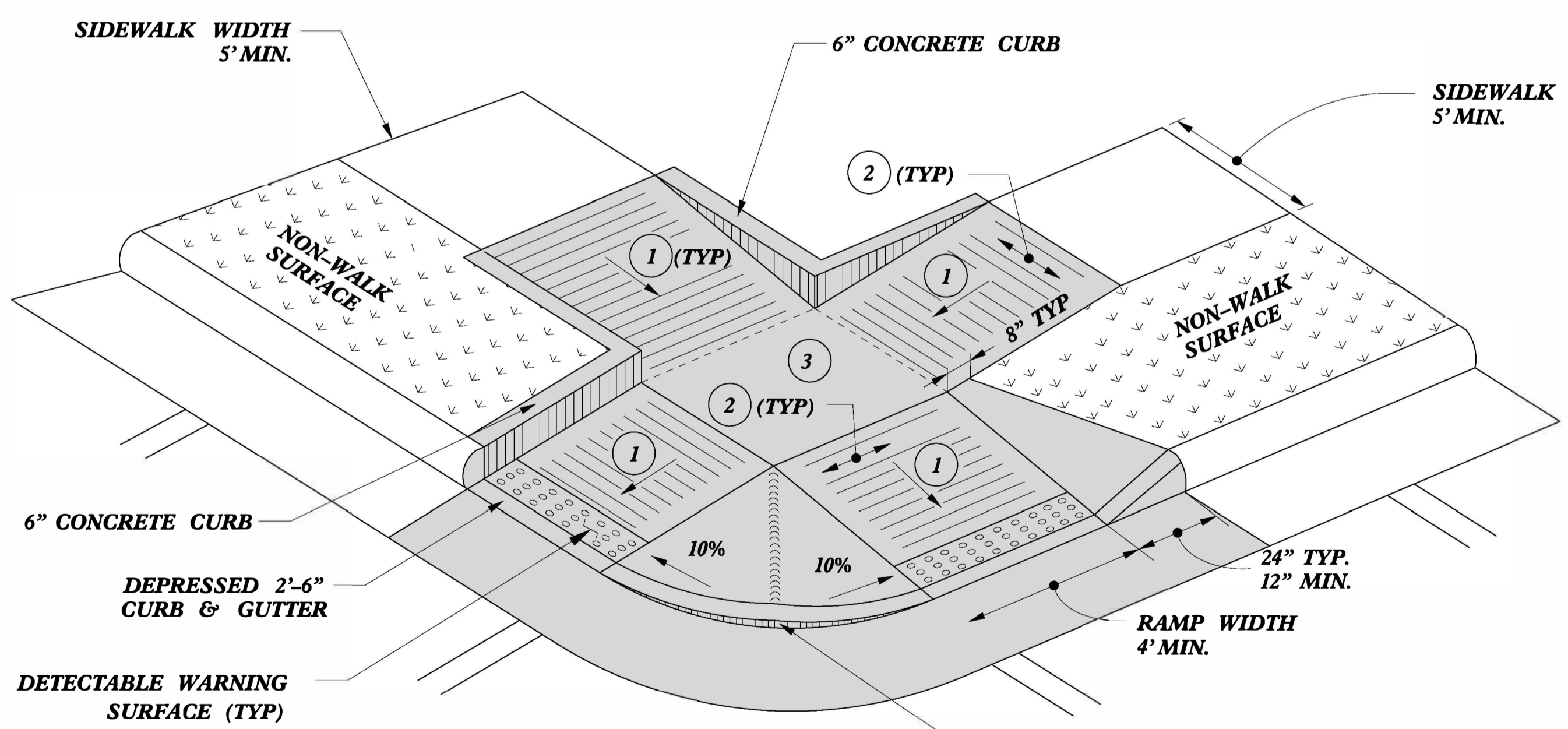
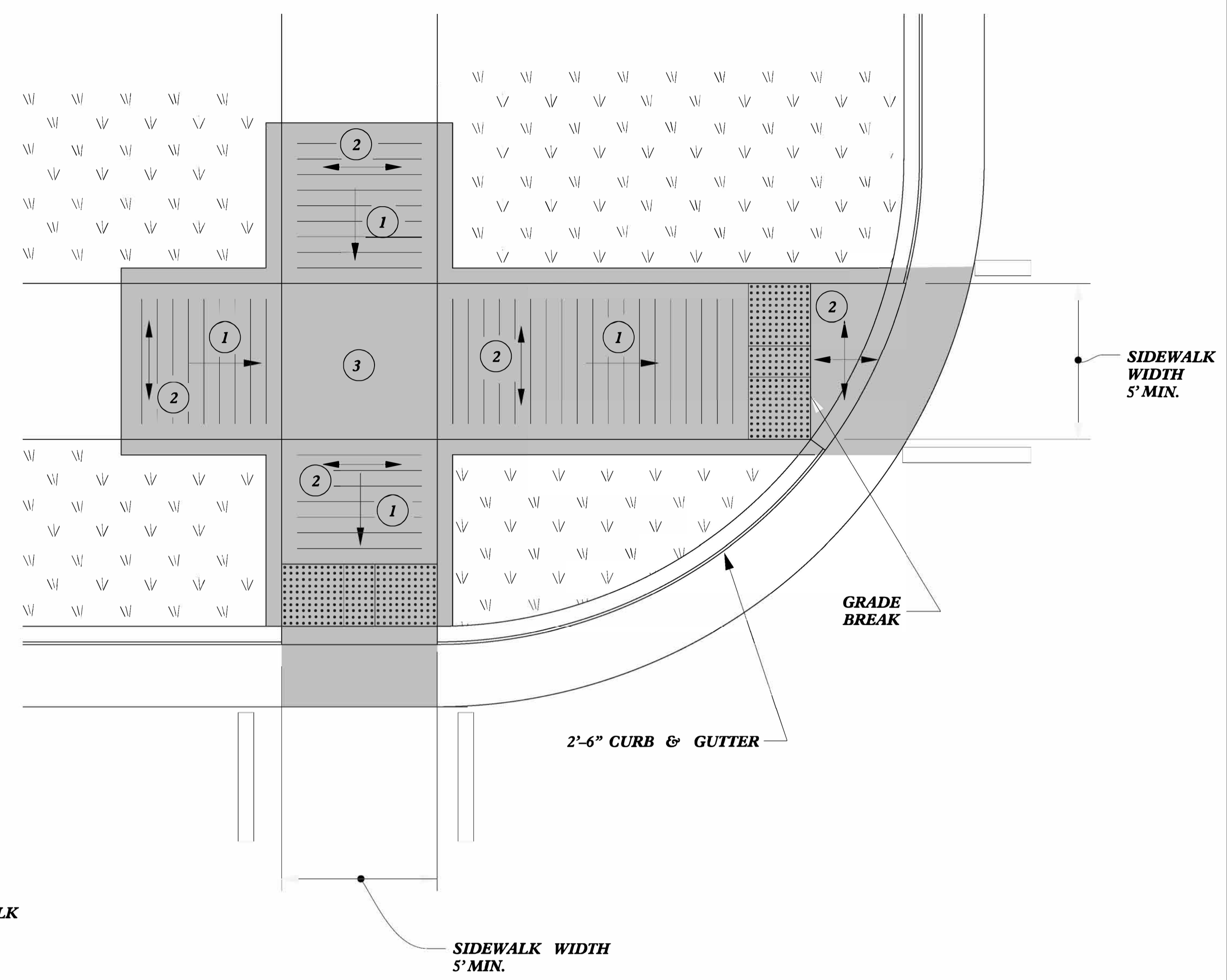

TYPE 5

TYPE 5A

- 1 8.33% (12:1) MAX RAMP SLOPE
- 2 CROSS SLOPE: 2.00%
- 3 CURB RAMPS REQUIRE A (4'-0") MINIMUM LANDING WITH A MAXIMUM CROSS SLOPE AND LONGITUDINAL SLOPE OF 2.00% WHERE PEDESTRIANS PERFORM TURNING MANEUVERS. SLOPE TO DRAIN TO CURB.



CONTRACT STANDARDS AND DEVELOPMENT UNIT
Office 919-707-6950 FAX 919-250-4119

CURB RAMPS

ORIGINAL BY: J.S. HOWERTON DATE: 7/7/11
 MODIFIED BY: _____ DATE: _____
 CHECKED BY: _____ DATE: _____
 FILE SPEC: .stds/2012CurbRamp/CurbRampDetails.dgn

REFER TO ROADWAY STANDARD DRAWING NUMBER 848.05 SHEET 3 OF 3 FOR ALL RAMP NOTES

5/14/99

5/14/99

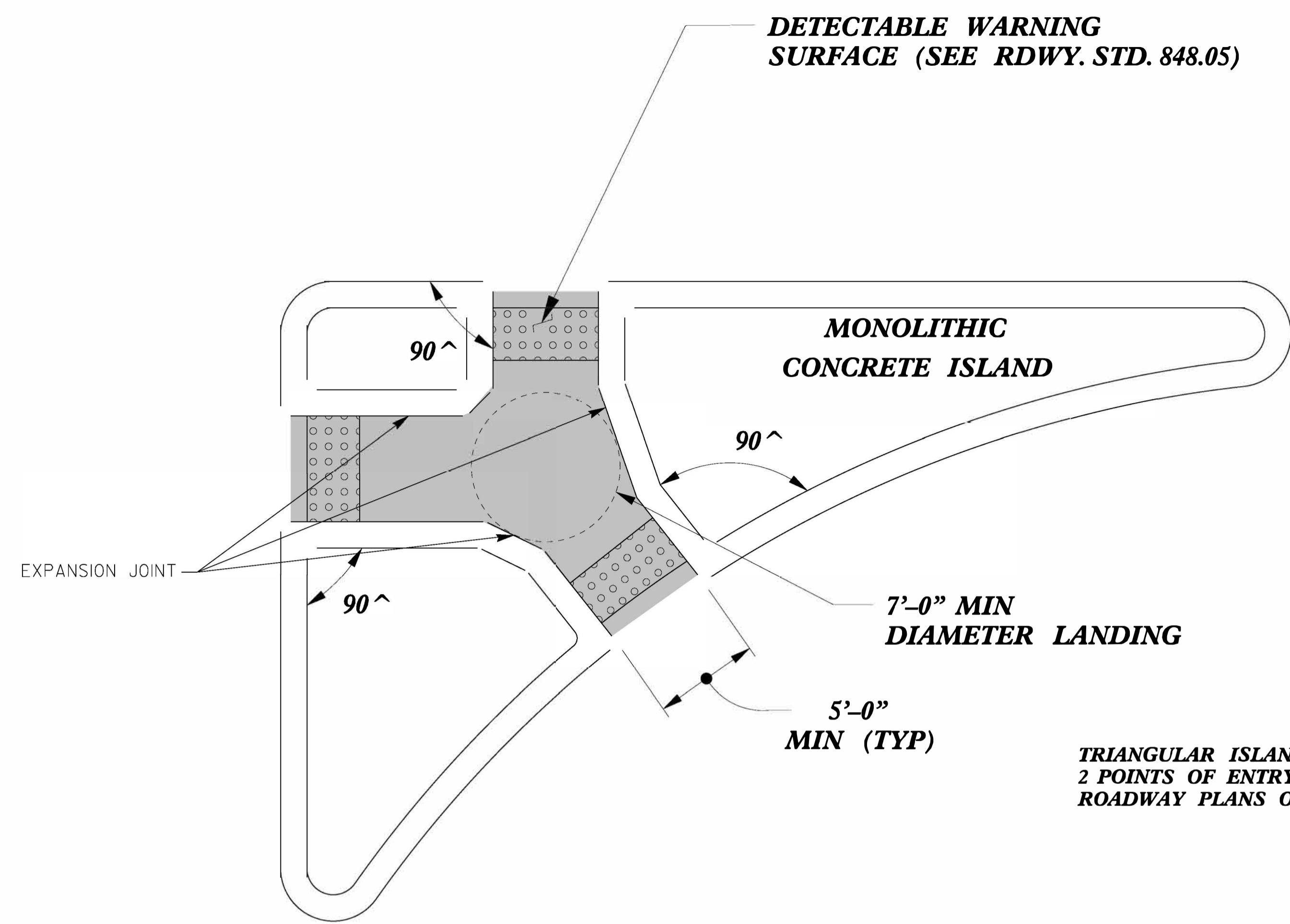

**PAY LIMITS FOR 2 OR 3 CURB RAMPS
(CALCULATE BASED ON NUMBER OF
SETS OF TRUNCATED DOMES)**

**TRIANGULAR ISLANDS MAY BE CONSTRUCTED WITH ONLY
2 POINTS OF ENTRY AND EXIT AS SHOWN IN THE
ROADWAY PLANS OR AS DIRECTED BY THE ENGINEER.**

**TRIANGULAR ISLAND
WITH CUT THROUGH
TYPE 6**

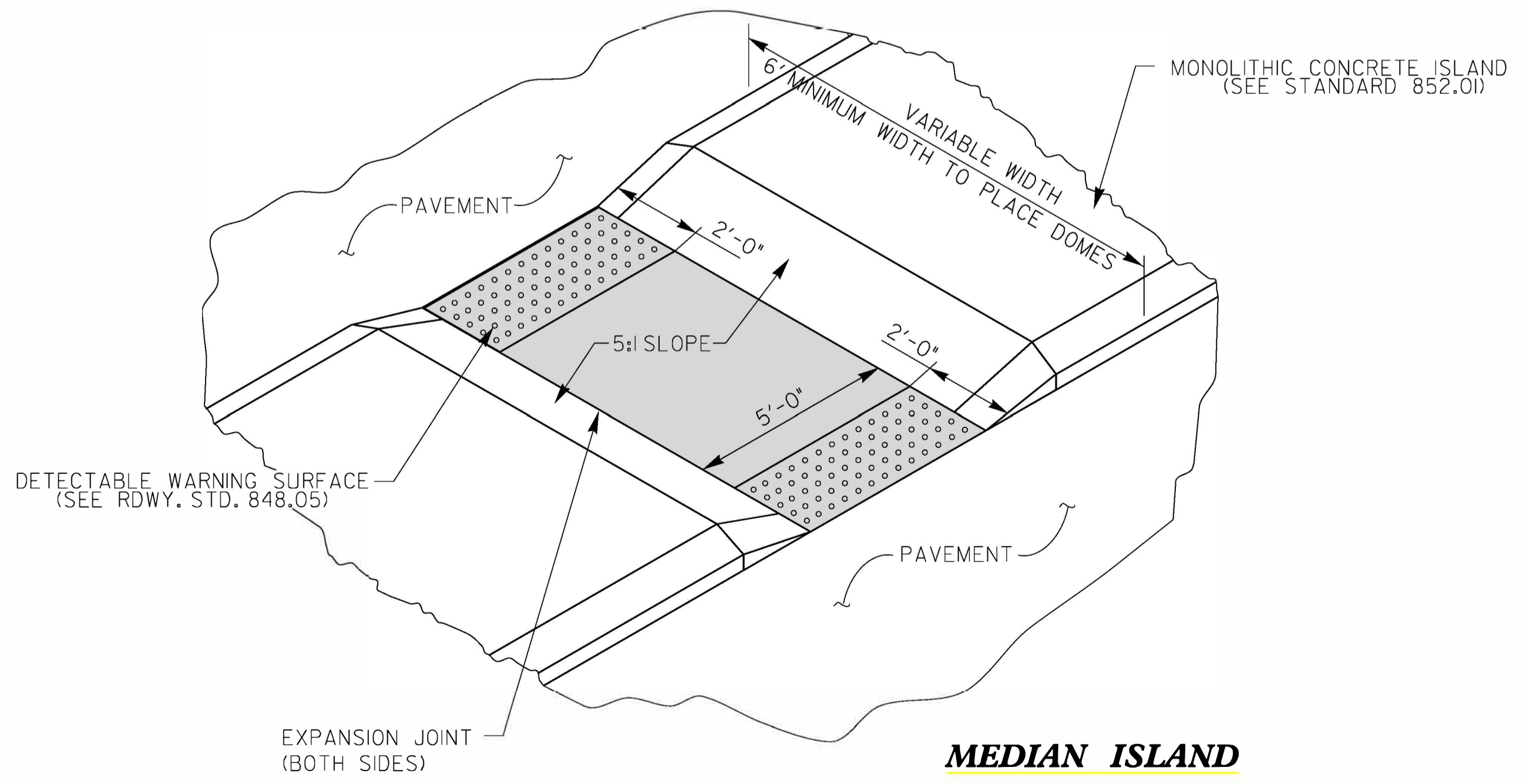

**MEDIAN ISLAND
WITH CUT THROUGH
TYPE 7**

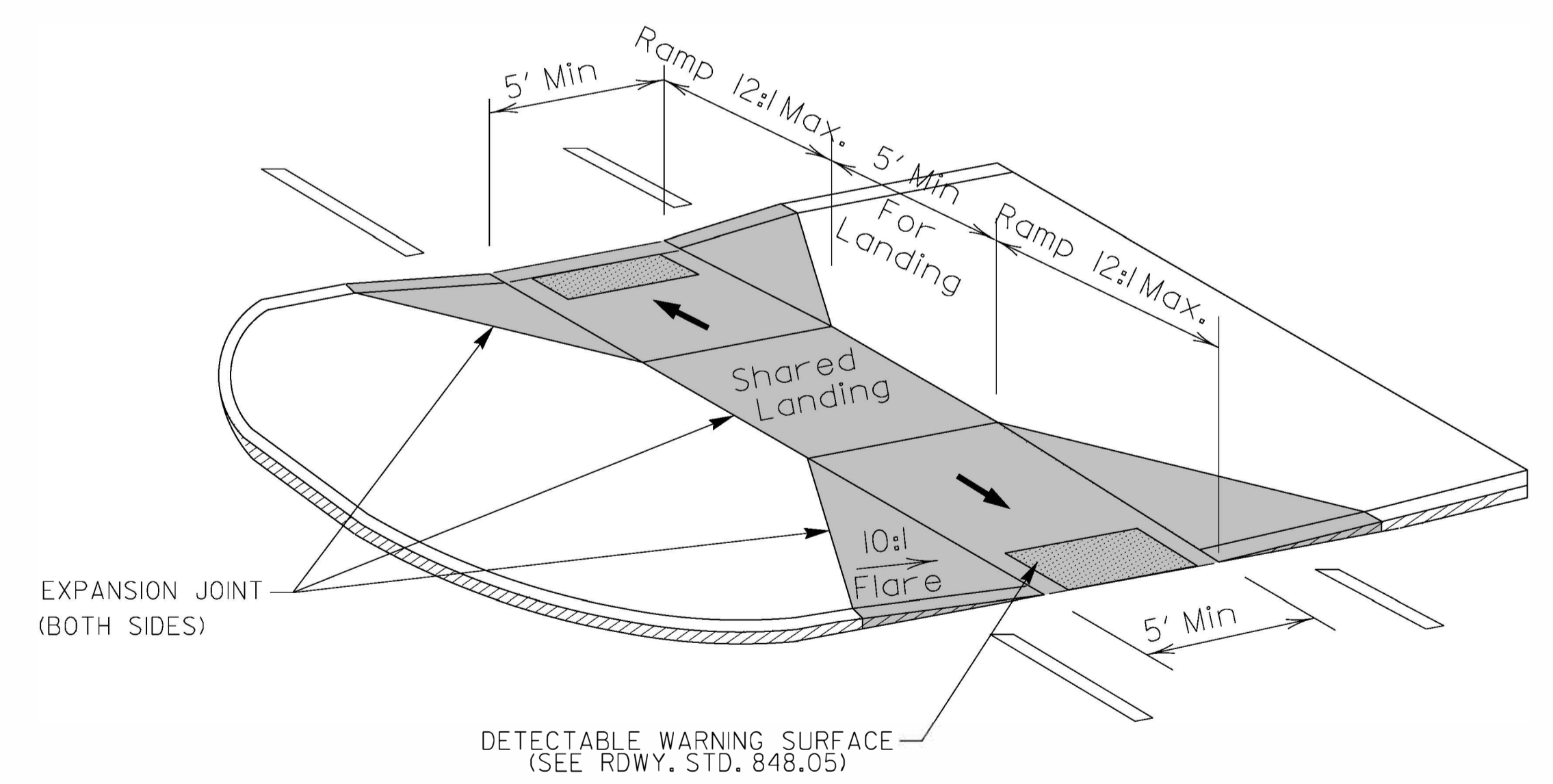

**MEDIAN ISLAND
CURB RAMPS
TYPE 8**

DOCUMENT NOT CONSIDERED FINAL
UNLESS ALL SIGNATURES COMPLETED

**CONTRACT STANDARDS
AND DEVELOPMENT UNIT**
Office 919-707-6950 FAX 919-250-4119

CURB RAMPS
Median or Turn Lane Islands

ORIGINAL BY: J.S. HOWERTON DATE: 7/7/11
MODIFIED BY: _____ DATE: _____
CHECKED BY: _____ DATE: _____
FILE SPEC: stds/2012CurbRamp/CurbRampDetails.dgn

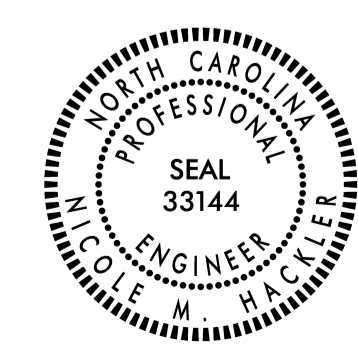

5/14/99

Special Detail A

BEFORE



AFTER

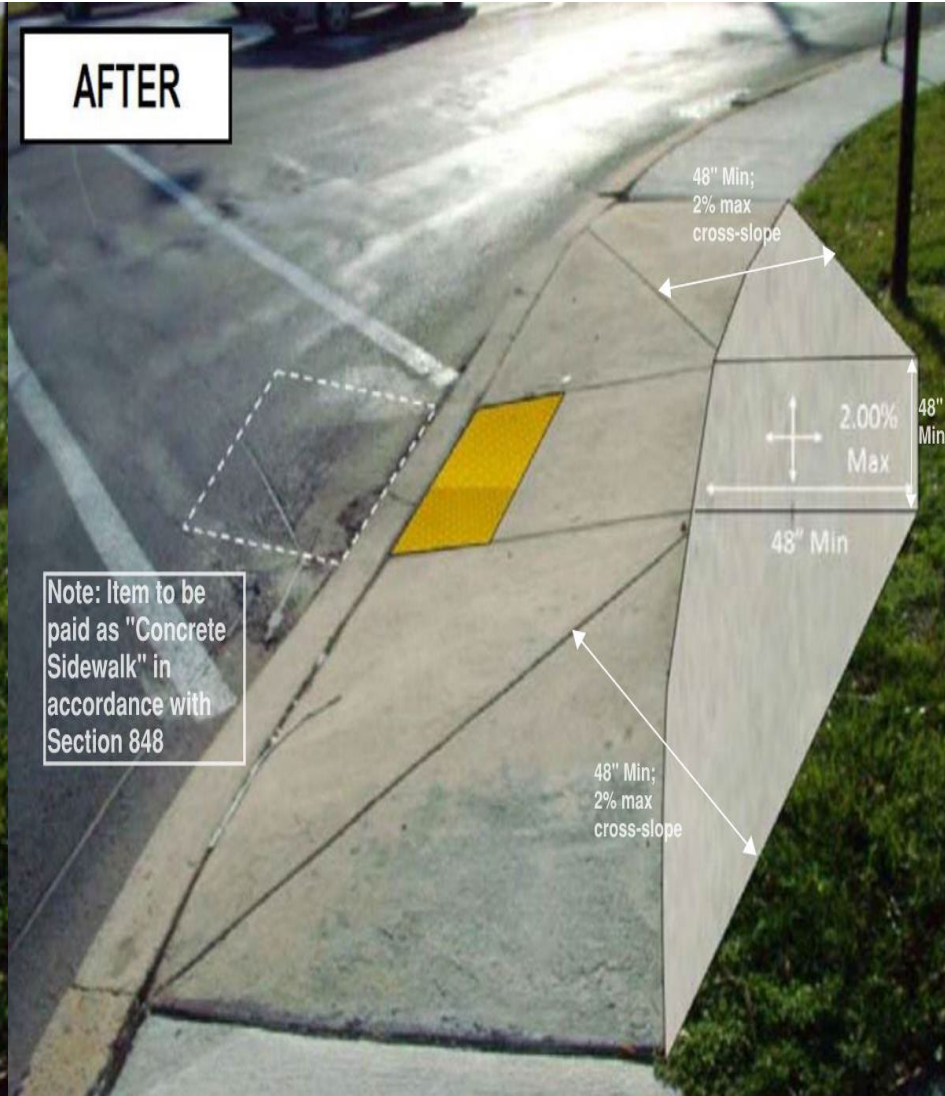

A	Standard 848.06
B	Detectable Warning Domes Only
C	Type 1
D	Type 1 Modified
E	Type 1A
F	Type 1B
G	Type 2
H	Type 2A
I	Type 2A Modified
J	Type 2B
K	Type 3
L	Type 3 Modified
M	Type 4
N	Type 4A
O	Type 4B
P	Type 4C
Q	Type 5
R	Type 5A
S	Type 6
T	Type 7
U	Type 8
V	Special Detail A



A	Standard 848.06
B	Detectable Warning Domes Only
C	Type 1
D	Type 1 Modified
E	Type 1A
F	Type 1B
G	Type 2
H	Type 2A
I	Type 2A Modified
J	Type 2B
K	Type 3
L	Type 3 Modified
M	Type 4
N	Type 4A
O	Type 4B
P	Type 4C
Q	Type 5
R	Type 5A
S	Type 6
T	Type 7
U	Type 8
V	Special Detail A



A	Standard 848.06
B	Detectable Warning Domes Only
C	Type 1
D	Type 1 Modified
E	Type 1A
F	Type 1B
G	Type 2
H	Type 2A
I	Type 2A Modified
J	Type 2B
K	Type 3
L	Type 3 Modified
M	Type 4
N	Type 4A
O	Type 4B
P	Type 4C
Q	Type 5
R	Type 5A
S	Type 6
T	Type 7
U	Type 8
V	Special Detail A

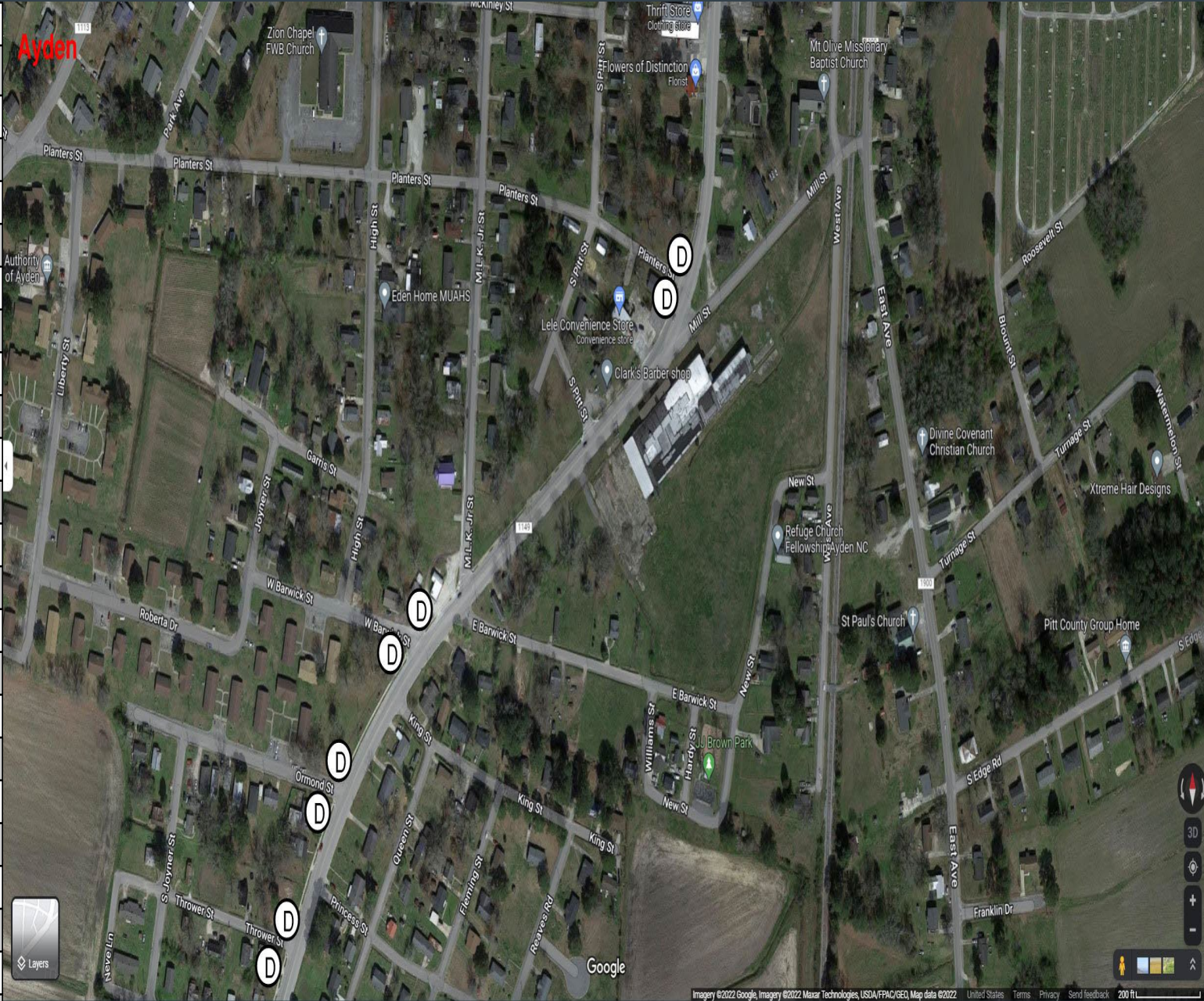

A	Standard 848.06
B	Detectable Warning Domes Only
C	Type 1
D	Type 1 Modified
E	Type 1A
F	Type 1B
G	Type 2
H	Type 2A
I	Type 2A Modified
J	Type 2B
K	Type 3
L	Type 3 Modified
M	Type 4
N	Type 4A
O	Type 4B
P	Type 4C
Q	Type 5
R	Type 5A
S	Type 6
T	Type 7
U	Type 8
V	Special Detail A



A	Standard 848.06
B	Detectable Warning Domes Only
C	Type 1
D	Type 1 Modified
E	Type 1A
F	Type 1B
G	Type 2
H	Type 2A
I	Type 2A Modified
J	Type 2B
K	Type 3
L	Type 3 Modified
M	Type 4
N	Type 4A
O	Type 4B
P	Type 4C
Q	Type 5
R	Type 5A
S	Type 6
T	Type 7
U	Type 8
V	Special Detail A



A	Standard 848.06
B	Detectable Warning Domes Only
C	Type 1
D	Type 1 Modified
E	Type 1A
F	Type 1B
G	Type 2
H	Type 2A
I	Type 2A Modified
J	Type 2B
K	Type 3
L	Type 3 Modified
M	Type 4
N	Type 4A
O	Type 4B
P	Type 4C
Q	Type 5
R	Type 5A
S	Type 6
T	Type 7
U	Type 8
V	Special Detail A

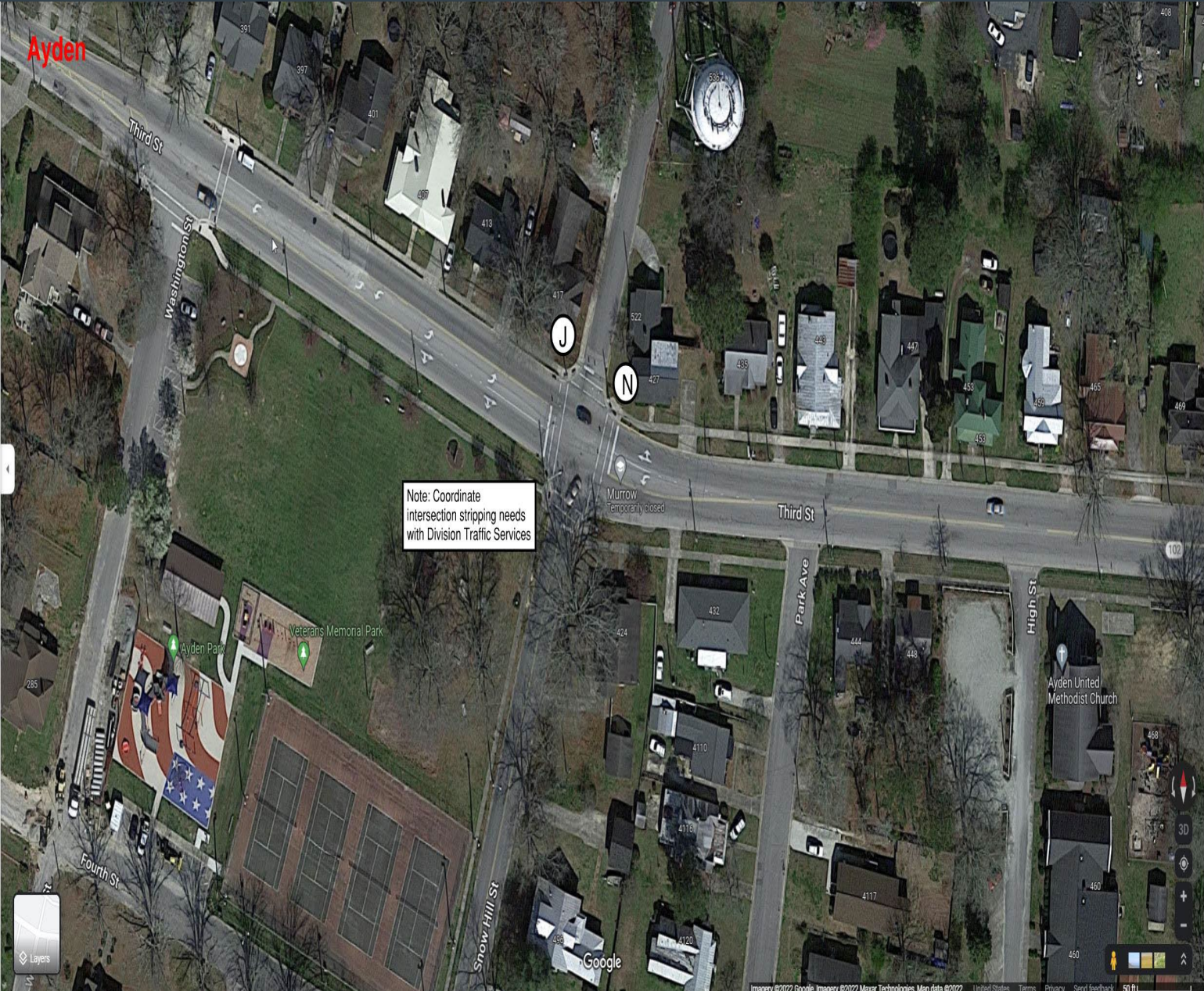

A	Standard 848.06
B	Detectable Warning Domes Only
C	Type 1
D	Type 1 Modified
E	Type 1A
F	Type 1B
G	Type 2
H	Type 2A
I	Type 2A Modified
J	Type 2B
K	Type 3
L	Type 3 Modified
M	Type 4
N	Type 4A
O	Type 4B
P	Type 4C
Q	Type 5
R	Type 5A
S	Type 6
T	Type 7
U	Type 8
V	Special Detail A



A	Standard 848.06
B	Detectable Warning Domes Only
C	Type 1
D	Type 1 Modified
E	Type 1A
F	Type 1B
G	Type 2
H	Type 2A
I	Type 2A Modified
J	Type 2B
K	Type 3
L	Type 3 Modified
M	Type 4
N	Type 4A
O	Type 4B
P	Type 4C
Q	Type 5
R	Type 5A
S	Type 6
T	Type 7
U	Type 8
V	Special Detail A



A	Standard 848.06
B	Detectable Warning Domes Only
C	Type 1
D	Type 1 Modified
E	Type 1A
F	Type 1B
G	Type 2
H	Type 2A
I	Type 2A Modified
J	Type 2B
K	Type 3
L	Type 3 Modified
M	Type 4
N	Type 4A
O	Type 4B
P	Type 4C
Q	Type 5
R	Type 5A
S	Type 6
T	Type 7
U	Type 8
V	Special Detail A

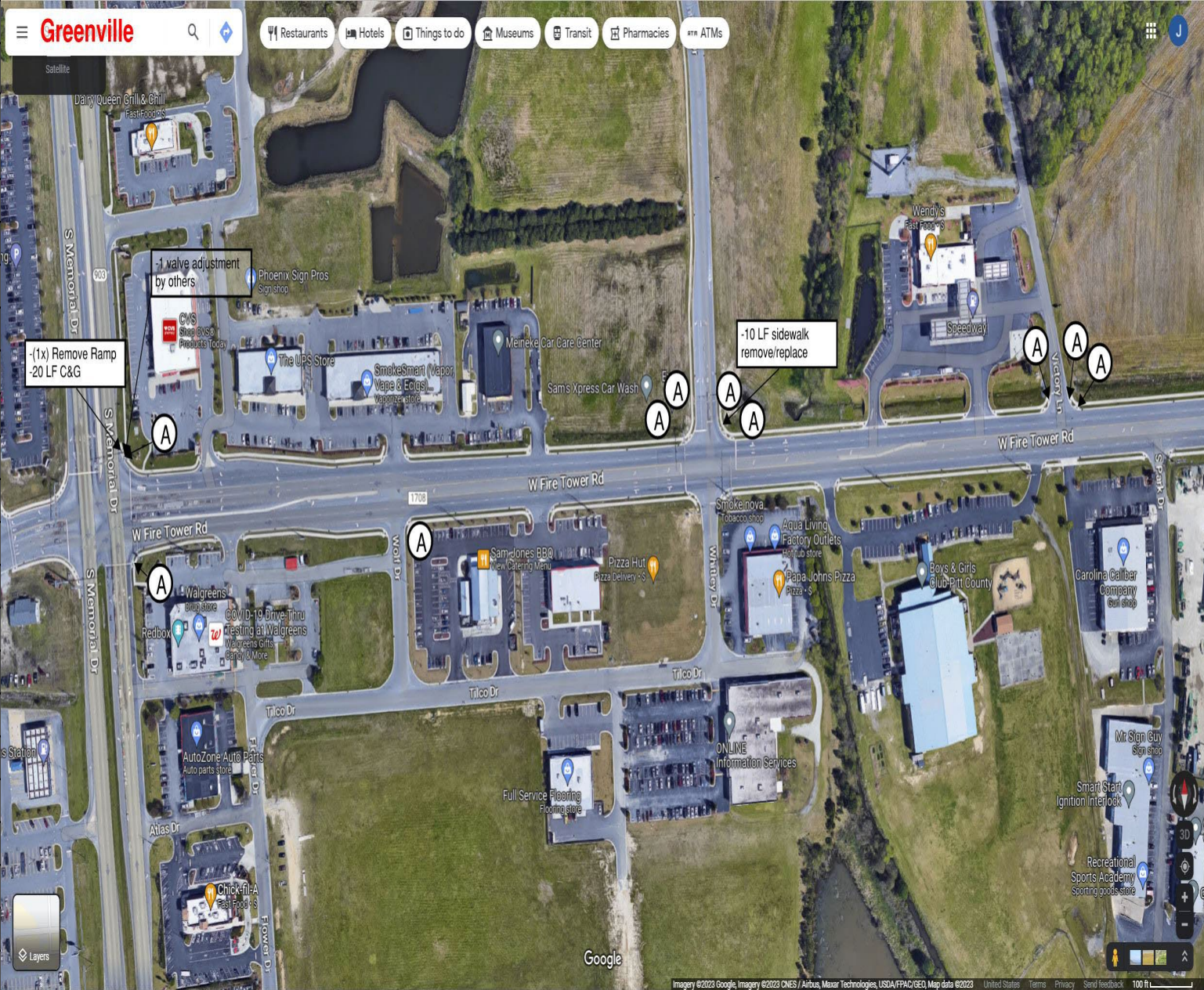

A	Standard 848.06
B	Detectable Warning Domes Only
C	Type 1
D	Type 1 Modified
E	Type 1A
F	Type 1B
G	Type 2
H	Type 2A
I	Type 2A Modified
J	Type 2B
K	Type 3
L	Type 3 Modified
M	Type 4
N	Type 4A
O	Type 4B
P	Type 4C
Q	Type 5
R	Type 5A
S	Type 6
T	Type 7
U	Type 8
V	Special Detail A

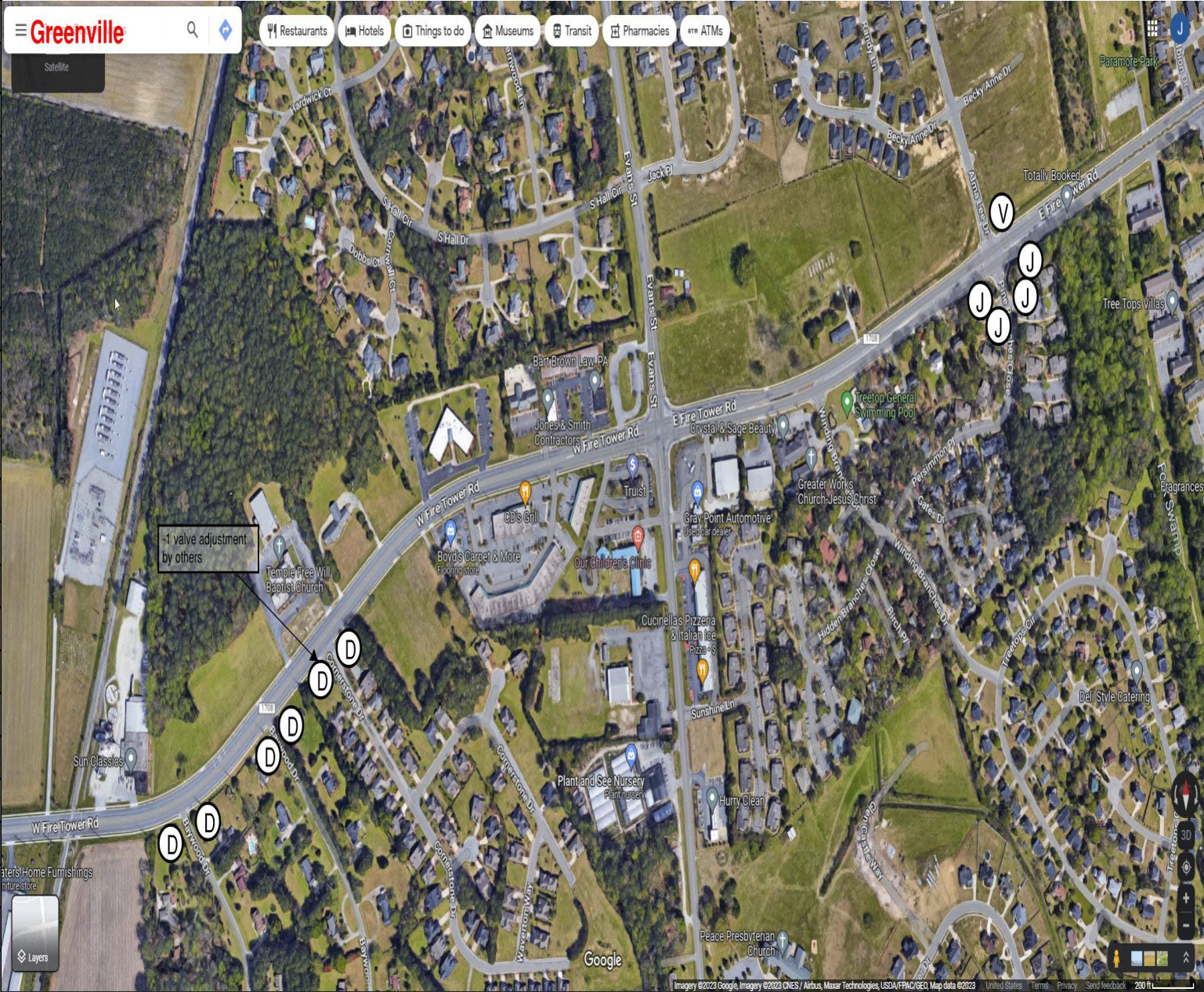

A	Standard 848.06
B	Detectable Warning Domes Only
C	Type 1
D	Type 1 Modified
E	Type 1A
F	Type 1B
G	Type 2
H	Type 2A
I	Type 2A Modified
J	Type 2B
K	Type 3
L	Type 3 Modified
M	Type 4
N	Type 4A
O	Type 4B
P	Type 4C
Q	Type 5
R	Type 5A
S	Type 6
T	Type 7
U	Type 8
V	Special Detail A



A	Standard 848.06
B	Detectable Warning Domes Only
C	Type 1
D	Type 1 Modified
E	Type 1A
F	Type 1B
G	Type 2
H	Type 2A
I	Type 2A Modified
J	Type 2B
K	Type 3
L	Type 3 Modified
M	Type 4
N	Type 4A
O	Type 4B
P	Type 4C
Q	Type 5
R	Type 5A
S	Type 6
T	Type 7
U	Type 8
V	Special Detail A

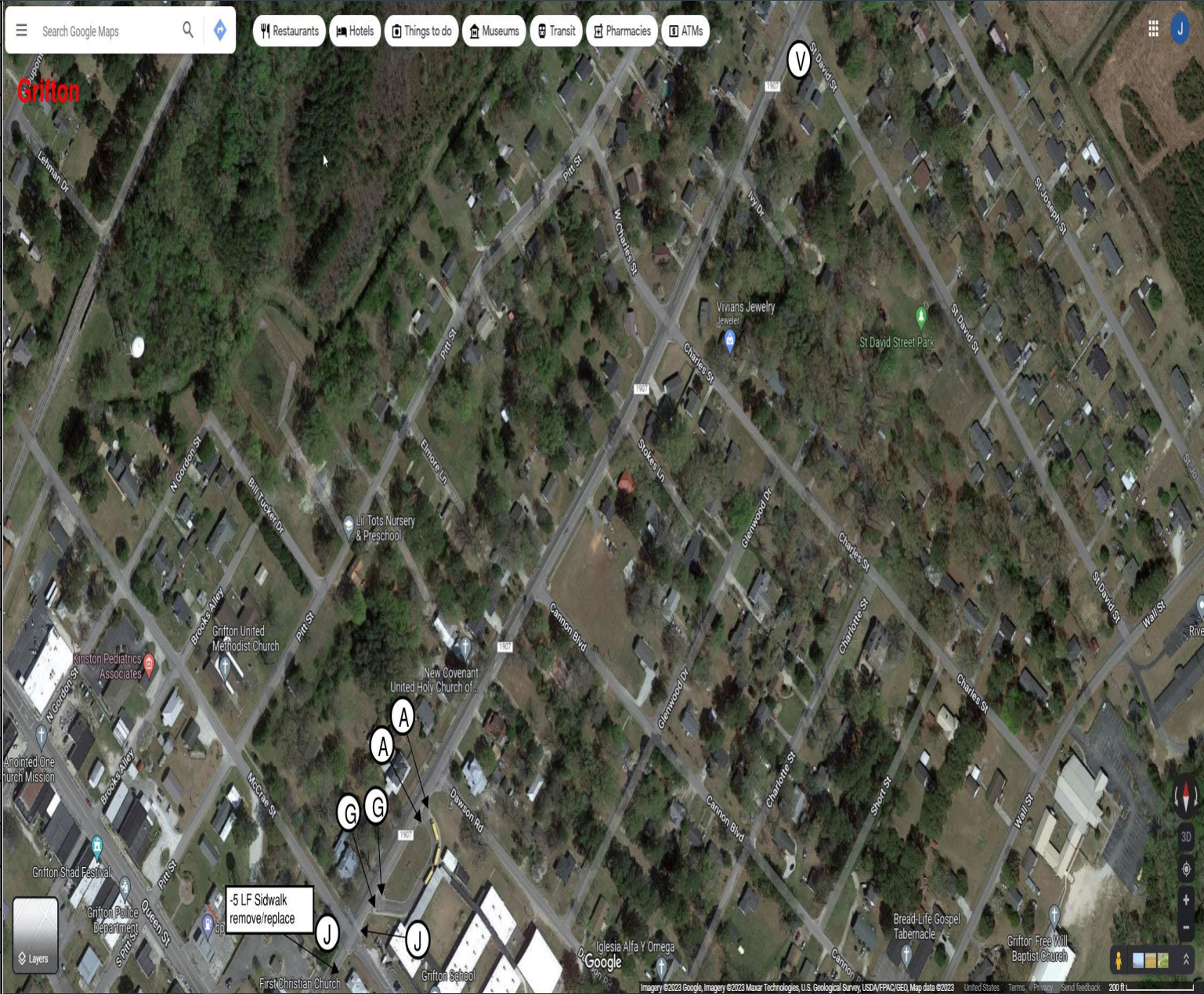

A	Standard 848.06
B	Detectable Warning Domes Only
C	Type 1
D	Type 1 Modified
E	Type 1A
F	Type 1B
G	Type 2
H	Type 2A
I	Type 2A Modified
J	Type 2B
K	Type 3
L	Type 3 Modified
M	Type 4
N	Type 4A
O	Type 4B
P	Type 4C
Q	Type 5
R	Type 5A
S	Type 6
T	Type 7
U	Type 8
V	Special Detail A



A	Standard 848.06
B	Detectable Warning Domes Only
C	Type 1
D	Type 1 Modified
E	Type 1A
F	Type 1B
G	Type 2
H	Type 2A
I	Type 2A Modified
J	Type 2B
K	Type 3
L	Type 3 Modified
M	Type 4
N	Type 4A
O	Type 4B
P	Type 4C
Q	Type 5
R	Type 5A
S	Type 6
T	Type 7
U	Type 8
V	Special Detail A

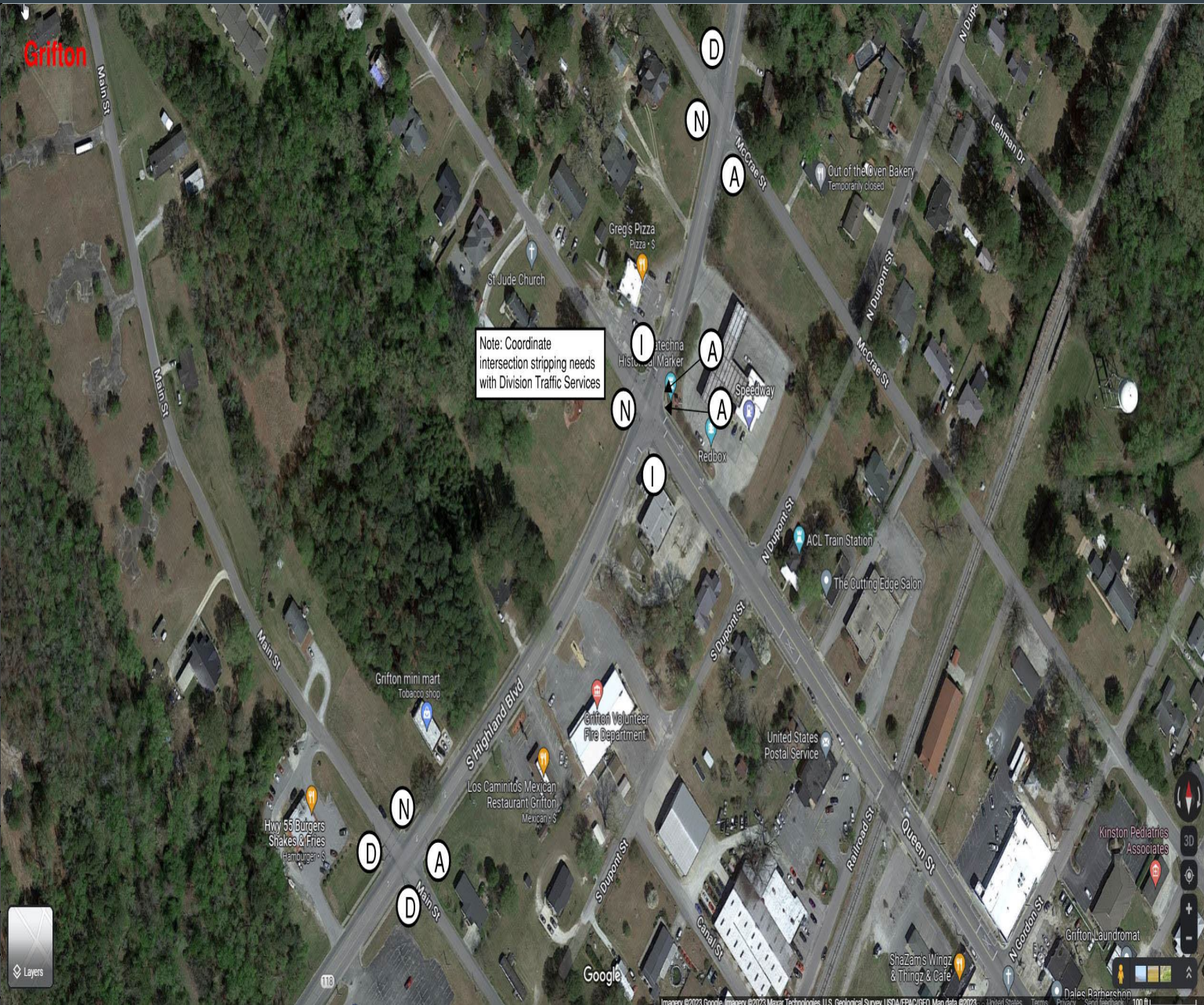

Note: Coordinate intersection striping needs with Division Traffic Services



A	Standard 848.06
B	Detectable Warning Domes Only
C	Type 1
D	Type 1 Modified
E	Type 1A
F	Type 1B
G	Type 2
H	Type 2A
I	Type 2A Modified
J	Type 2B
K	Type 3
L	Type 3 Modified
M	Type 4
N	Type 4A
O	Type 4B
P	Type 4C
Q	Type 5
R	Type 5A
S	Type 6
T	Type 7
U	Type 8
V	Special Detail A



A	Standard 848.06
B	Detectable Warning Domes Only
C	Type 1
D	Type 1 Modified
E	Type 1A
F	Type 1B
G	Type 2
H	Type 2A
I	Type 2A Modified
J	Type 2B
K	Type 3
L	Type 3 Modified
M	Type 4
N	Type 4A
O	Type 4B
P	Type 4C
Q	Type 5
R	Type 5A
S	Type 6
T	Type 7
U	Type 8
V	Special Detail A



A	Standard 848.06
B	Detectable Warning Domes Only
C	Type 1
D	Type 1 Modified
E	Type 1A
F	Type 1B
G	Type 2
H	Type 2A
I	Type 2A Modified
J	Type 2B
K	Type 3
L	Type 3 Modified
M	Type 4
N	Type 4A
O	Type 4B
P	Type 4C
Q	Type 5
R	Type 5A
S	Type 6
T	Type 7
U	Type 8
V	Special Detail A

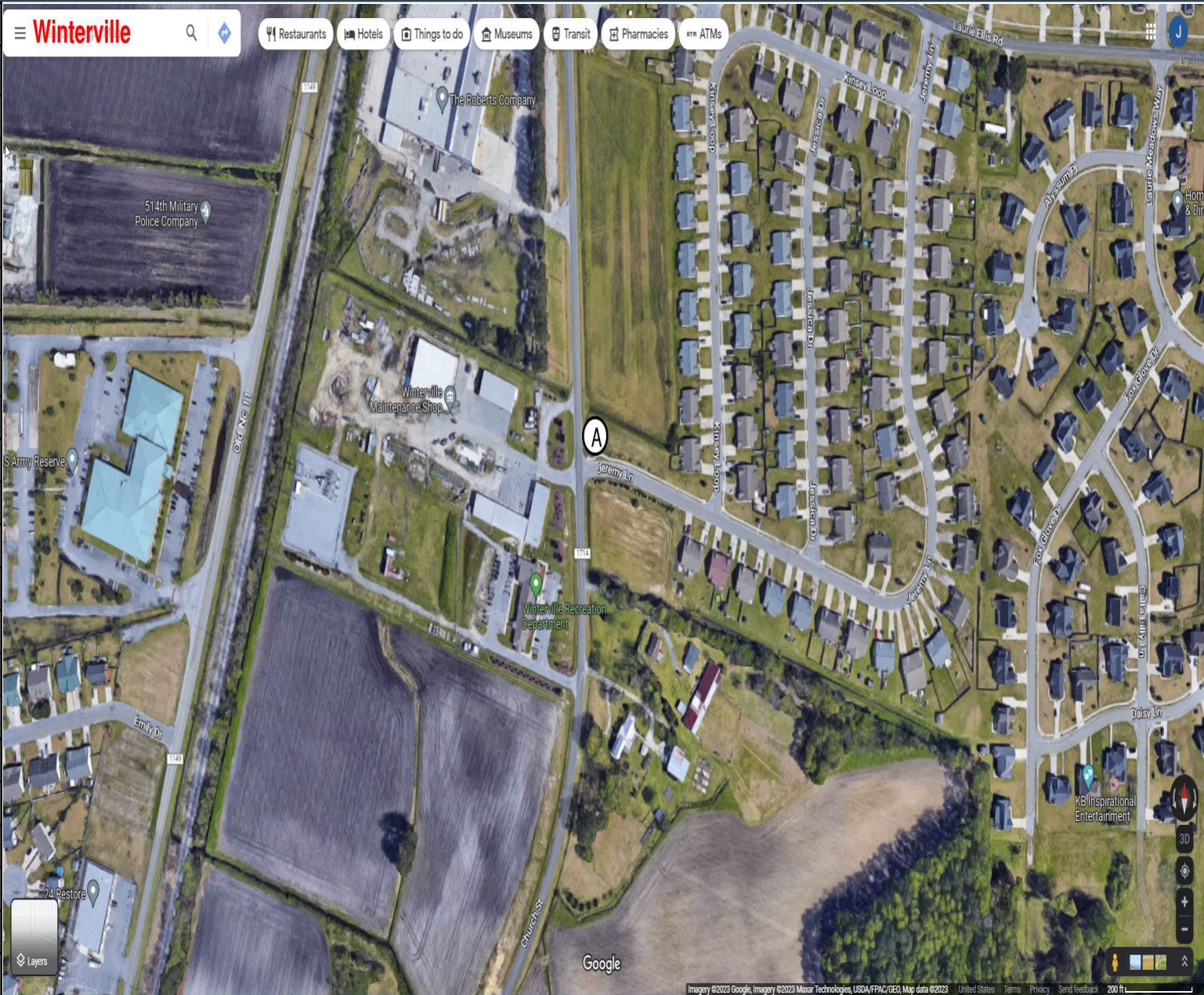

A	Standard 848.06
B	Detectable Warning Domes Only
C	Type 1
D	Type 1 Modified
E	Type 1A
F	Type 1B
G	Type 2
H	Type 2A
I	Type 2A Modified
J	Type 2B
K	Type 3
L	Type 3 Modified
M	Type 4
N	Type 4A
O	Type 4B
P	Type 4C
Q	Type 5
R	Type 5A
S	Type 6
T	Type 7
U	Type 8
V	Special Detail A

