

TIP PROJECT: 17BP.2.R.24

CONTRACT: DB00119

See Sheet 1-A For Index of Sheets

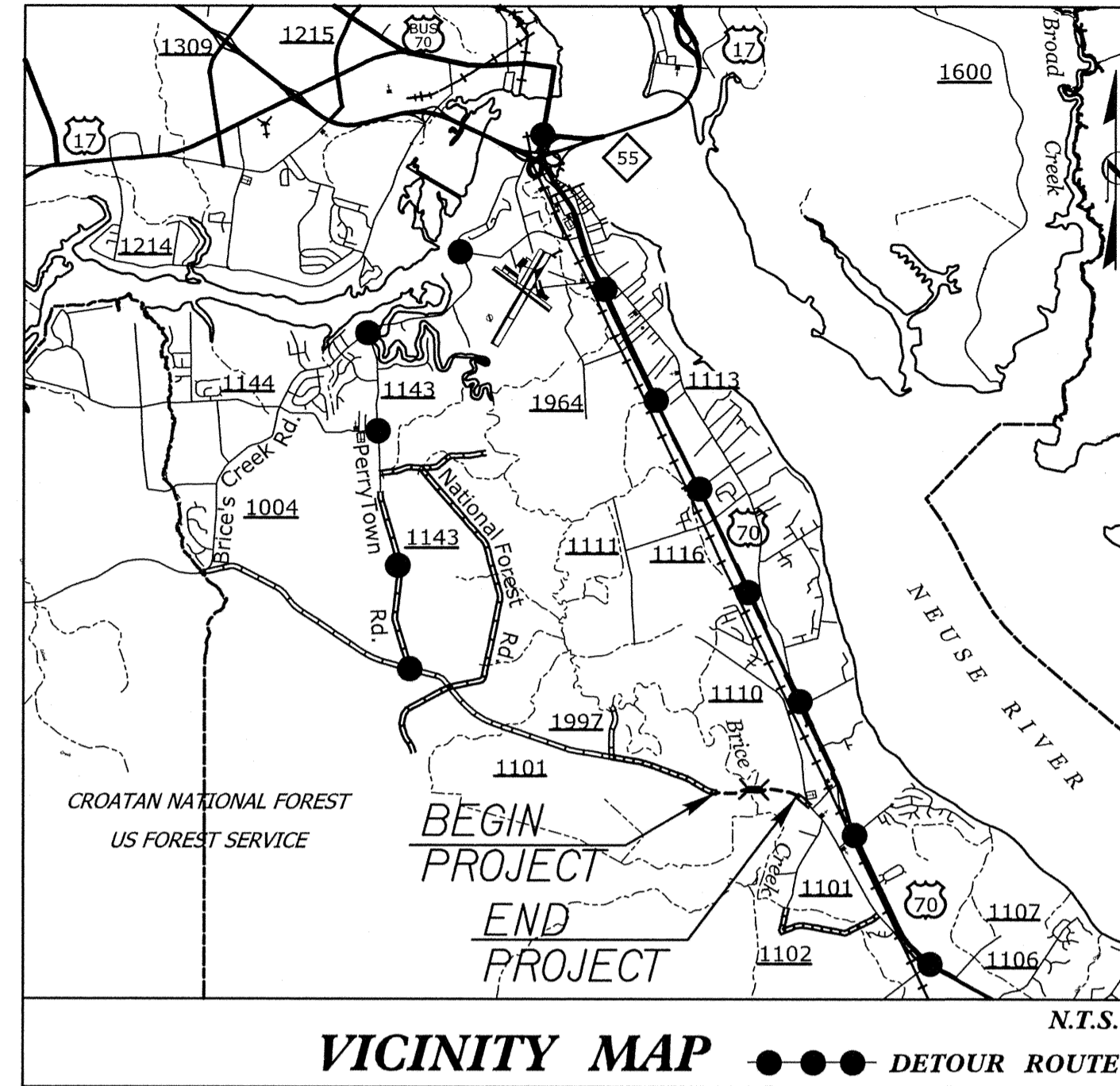

STATE OF NORTH CAROLINA
DIVISION OF HIGHWAYS

CRAVEN COUNTY

**LOCATION: BRIDGE NO. 009 OVER BRICES CREEK
ON SR 1101 (COUNTYLINE RD.)**

**TYPE OF WORK: GRADING, PAVING, STRUCTURE,
DRAINAGE, & GUARDRAIL**

STATE	PROJECT REFERENCE NO.	SHEET NO.	TOTAL SHEETS
NC	17BP.2.R.24	1	X
STATE PROJ. NO.	DESCRIPTION		
17BP.2.R.24	CONST		

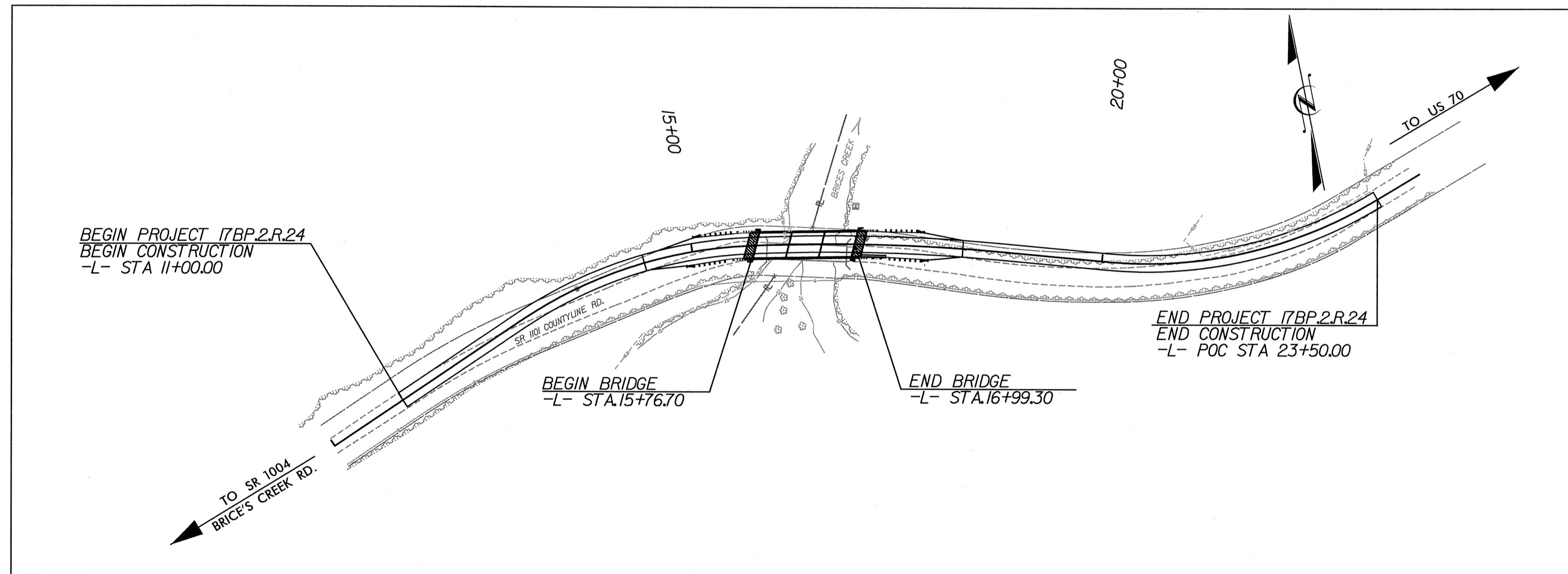

CLEARING ON THIS PROJECT SHALL BE PERFORMED TO THE LIMITS ESTABLISHED BY METHOD II.

GRAPHIC SCALES

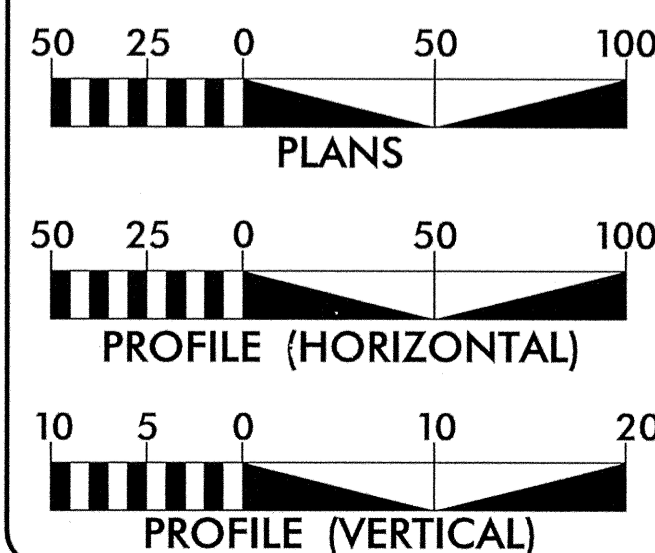

DESIGN DATA

ADT 2009 = < 400
ADT 2035 = 800
DHV = 10%
D = 60%
T = 6% *
STATUTORY ADVISORY = 55 MPH
= 40 MPH
* TTST 2% DUAL 4%

PROJECT LENGTH

LENGTH OF ROADWAY TIP PROJECT 17BP.2.R.24 = 0.22 MI.
LENGTH OF STRUCTURE TIP PROJECT 17BP.2.R.24 = 0.02 MI.
TOTAL LENGTH OF TIP PROJECT 17BP.2.R.24 = 0.24 MI.



Prepared In the Office of:
HNTB NORTH CAROLINA, P.C.
343 E. Six Forks Road, Suite 200
Raleigh, North Carolina 27609
NC License No: C-1554

2012 STANDARD SPECIFICATIONS

RIGHT OF WAY DATE:
NOVEMBER 30, 2012

LETTING DATE:
JULY 24, 2013

ENRICO A. ROQUE, P.E.
PROJECT ENGINEER

ANTHONY THOMPSON, P.E.
PROJECT DESIGNER

MARIA ROGERSON, P.E.
NCDOT CONTACT

HYDRAULICS ENGINEER

Signature: James C. Byrd, P.E.
6/14/13

ROADWAY DESIGN ENGINEER

Signature: Maria Rogerson, P.E.
6/14/13

DIVISION OF HIGHWAYS
STATE OF NORTH CAROLINA

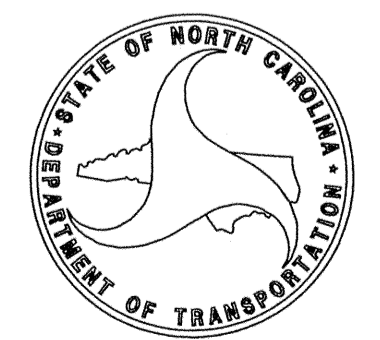

STATE HIGHWAY DESIGN ENGINEER

P.E.

\$\$\$\$\$DATE\$\$\$\$\$
\$\$\$\$\$SYS TIME\$\$\$\$\$
\$\$\$\$\$\$\$\$\$\$

REVISIONS

INDEX OF SHEETS

SHEET NUMBER	SHEET
1	TITLE SHEET
1-A	INDEX OF SHEETS, GENERAL NOTES & LIST OF STANDARDS
1-B	SYMBOLS SHEET
2	TYPICAL SECTION SHEET
3	EARTHWORK, PAVEMENT REMOVAL, GUARDRAIL SUMMARY, ROW SUMMARY, & DRAINAGE SUMMARY SHEET
4	PLAN & PROFILE SHEET
TMP-1 THRU TMP-2	TRAFFIC CONTROL PLANS
EC-1	EROSION CONTROL TITLE SHEET
EC-2	EROSION CONTROL - COIR FIBER WATTLE DETAIL
EC-3	EROSION CONTROL- WATTLE / SILT FENCE BREAK DETAIL
EC-4	EROSION CONTROL - SOIL STABILIZATION TIME FRAMES
EC-5	EROSION CONTROL SHEET
P-1	PERMIT DRAWING
X-1 THRU X-10	-L- CROSS SECTION SHEETS
S-1 THRU S-16	BRIDGE PLANS

GENERAL NOTES: 2012 SPECIFICATIONS
 EFFECTIVE: 01-17-12
 REVISED: 11/01/11

GRADE LINE:
 GRADING AND SURFACING:

THE GRADE LINES SHOWN DENOTE THE FINISHED ELEVATION OF THE PROPOSED SURFACING AT GRADE POINTS SHOWN ON THE TYPICAL SECTIONS. GRADE LINES MAY BE ADJUSTED AT THEIR BEGINNING AND ENDING AND AT STRUCTURES AS DIRECTED BY THE ENGINEER IN ORDER TO SECURE A PROPER TIE-IN.

CLEARING:

CLEARING ON THIS PROJECT SHALL BE PERFORMED TO THE LIMITS ESTABLISHED BY METHOD II.

SUPERELEVATION:

ALL CURVES ON THIS PROJECT SHALL BE SUPERELEVATED IN ACCORDANCE WITH STD. NO. 225.04 USING THE RATE OF SUPERELEVATION AND RUNOFF SHOWN ON THE PLANS. SUPERELEVATION IS TO BE REVOLVED ABOUT THE GRADE POINTS SHOWN ON THE TYPICAL SECTIONS.

SHOULDER CONSTRUCTION:

ASPHALT, EARTH, AND CONCRETE SHOULDER CONSTRUCTION ON THE HIGH SIDE OF SUPERELEVATED CURVES SHALL BE IN ACCORDANCE WITH STD. NO. 560.01.

GUARDRAIL:

THE GUARDRAIL LOCATIONS SHOWN ON THE PLANS MAY BE ADJUSTED DURING CONSTRUCTION AS DIRECTED BY THE ENGINEER. THE CONTRACTOR SHOULD CONSULT WITH THE ENGINEER PRIOR TO ORDERING GUARDRAIL MATERIAL.

UTILITIES:

UTILITY OWNERS ON THIS PROJECT ARE Gas ¹³² Piedmont Natural Gas s
 ANY RELOCATION OF EXISTING UTILITIES WILL BE ACCOMPLISHED BY OTHERS.

RIGHT-OF-WAY MARKERS:

ALL RIGHT-OF-WAY MARKERS ON THIS PROJECT SHALL BE PLACED BY OTHERS.

2012 ROADWAY ENGLISH STANDARD DRAWINGS

The following Roadway Standards as appear in "Roadway Standard Drawings" Highway Design Branch - N. C. Department of Transportation - Raleigh, N. C., Dated January, 2012 are applicable to this project and by reference hereby are considered a part of these plans:

STD.NO.	TITLE
DIVISION 2 - EARTHWORK	
200.02	Method of Clearing - Method II
225.02	Guide for Grading Subgrade - Secondary and Local
225.04	Method of Obtaining Superelevation - Two Lane Pavement
DIVISION 3 - PIPE CULVERTS	
300.01	Method of Pipe Installation
DIVISION 4 - MAJOR STRUCTURES	
422.10	Reinforced Bridge Approach Fills
DIVISION 5 - SUBGRADE, BASES AND SHOULDERS	
560.01	Method of Shoulder Construction - High Side of Superelevated Curve - Method I
DIVISION 8 - INCIDENTALS	
806.01	Concrete Right-of-Way Marker
816.04	Markers for Drainage Structure and Concrete Pad
840.36	Traffic Bearing Grated Drop Inlet - for Steel (840.37) Double Frame and Grates
840.37	Steel Grate and Frame
846.01	Concrete Curb, Gutter and Curb & Gutter
846.04	Drop Inlet Installation in Shoulder Berm Gutter
862.01	Guardrail Placement
862.02	Guardrail Installation
862.03	Structure Anchor Units
876.01	Rip Rap in Channels
876.02	Guide for Rip Rap at Pipe Outlets













Note: Not to Scale

*S.U.E. = *Subsurface Utility Engineering*











STATE OF NORTH CAROLINA
DIVISION OF HIGHWAYS

CONVENTIONAL PLAN SHEET SYMBOLS









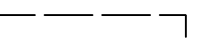

BOUNDARIES AND PROPERTY:

State Line	_____
County Line	_____
Township Line	_____
City Line	_____
Reservation Line	_____
Property Line	_____
Existing Iron Pin	_____ 
Property Corner	_____ 
Property Monument	_____ 
Parcel/Sequence Number	_____ 
Existing Fence Line	_____ 
Proposed Woven Wire Fence	_____ 
Proposed Chain Link Fence	_____ 
Proposed Barbed Wire Fence	_____ 
Existing Wetland Boundary	_____ 
Proposed Wetland Boundary	_____ 
Existing Endangered Animal Boundary	_____ 
Existing Endangered Plant Boundary	_____ 

BUILDINGS AND OTHER CULTURE:

Gas Pump Vent or U/G Tank Cap	_____ 
Sign	_____ 
Well	_____ 
Small Mine	_____ 
Foundation	_____ 
Area Outline	_____ 
Cemetery	_____ 
Building	_____ 
School	_____ 
Church	_____ 
Dam	_____ 













HYDROLOGY:

Stream or Body of Water	_____
Hydro, Pool or Reservoir	_____ 
Jurisdictional Stream	_____ 
Buffer Zone 1	_____ 
Buffer Zone 2	_____ 
Flow Arrow	_____ 
Disappearing Stream	_____ 
Spring	_____ 
Wetland	_____ 
Proposed Lateral, Tail, Head Ditch	_____ 
False Sump	_____ 







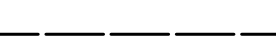
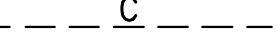
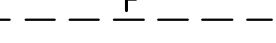

RAILROADS:

Standard Gauge	_____ 
RR Signal Milepost	_____ 
Switch	_____ 
RR Abandoned	_____ 
RR Dismantled	_____ 

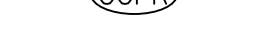
RIGHT OF WAY:

Baseline Control Point	_____ 
Existing Right of Way Marker	_____ 
Existing Right of Way Line	_____ 
Proposed Right of Way Line	_____ 
Proposed Right of Way Line with Iron Pin and Cap Marker	_____ 
Proposed Right of Way Line with Concrete or Granite Marker	_____ 
Existing Control of Access	_____ 
Proposed Control of Access	_____ 
Existing Easement Line	_____ 
Proposed Temporary Construction Easement	_____ 
Proposed Temporary Drainage Easement	_____ 
Proposed Permanent Drainage Easement	_____ 
Proposed Permanent Utility Easement	_____ 





ROADS AND RELATED FEATURES:

Existing Edge of Pavement	_____ 
Existing Curb	_____ 
Proposed Slope Stakes Cut	_____ 
Proposed Slope Stakes Fill	_____ 
Proposed Wheel Chair Ramp	_____ 
Proposed Wheel Chair Ramp Curb Cut	_____ 
Curb Cut for Future Wheel Chair Ramp	_____ 
Existing Metal Guardrail	_____ 
Proposed Guardrail	_____ 
Existing Cable Guiderail	_____ 
Proposed Cable Guiderail	_____ 
Equality Symbol	_____ 
Pavement Removal	_____ 



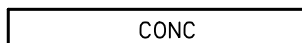
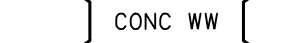

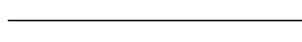
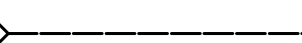

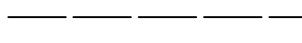
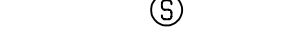
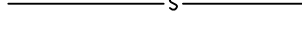



VEGETATION:

Single Tree	_____ 
Single Shrub	_____ 
Hedge	_____ 
Woods Line	_____ 
Orchard	_____ 
Vineyard	_____ 













EXISTING STRUCTURES:

MAJOR:	
Bridge, Tunnel or Box Culvert	_____ 
Bridge Wing Wall, Head Wall and End Wall	_____ 
MINOR:	
Head and End Wall	_____ 
Pipe Culvert	_____ 
Footbridge	_____ 
Drainage Box: Catch Basin, DI or JB	_____ 
Paved Ditch Gutter	_____ 
Storm Sewer Manhole	_____ 
Storm Sewer	_____ 







UTILITIES:

POWER:	
Existing Power Pole	_____ 
Proposed Power Pole	_____ 
Existing Joint Use Pole	_____ 
Proposed Joint Use Pole	_____ 
Power Manhole	_____ 
Power Line Tower	_____ 
Power Transformer	_____ 
U/G Power Cable Hand Hole	_____ 
H-Frame Pole	_____ 
Recorded U/G Power Line	_____ 
Designated U/G Power Line (S.U.E.*)	_____ 









TELEPHONE:

Existing Telephone Pole	_____ 
Proposed Telephone Pole	_____ 
Telephone Manhole	_____ 
Telephone Booth	_____ 
Telephone Pedestal	_____ 
Telephone Cell Tower	_____ 
U/G Telephone Cable Hand Hole	_____ 
Recorded U/G Telephone Cable	_____ 
Designated U/G Telephone Cable (S.U.E.*)	_____ 
Recorded U/G Telephone Conduit	_____ 
Designated U/G Telephone Conduit (S.U.E.*)	_____ 
Recorded U/G Fiber Optics Cable	_____ 
Designated U/G Fiber Optics Cable (S.U.E.*)	_____ 





WATER:

Water Manhole	_____ 
Water Meter	_____ 
Water Valve	_____ 
Water Hydrant	_____ 
Recorded U/G Water Line	_____ 
Designated U/G Water Line (S.U.E.*)	_____ 
Above Ground Water Line	_____ 







TV:

TV Satellite Dish	_____ 
TV Pedestal	_____ 
TV Tower	_____ 
U/G TV Cable Hand Hole	_____ 
Recorded U/G TV Cable	_____ 
Designated U/G TV Cable (S.U.E.*)	_____ 
Recorded U/G Fiber Optic Cable	_____ 
Designated U/G Fiber Optic Cable (S.U.E.*)	_____ 











GAS:

Gas Valve	_____ 
Gas Meter	_____ 
Recorded U/G Gas Line	_____ 
Designated U/G Gas Line (S.U.E.*)	_____ 
Above Ground Gas Line	_____ 

SANITARY SEWER:

Sanitary Sewer Manhole	_____ 
Sanitary Sewer Cleanout	_____ 
U/G Sanitary Sewer Line	_____ 
Above Ground Sanitary Sewer	_____ 
Recorded SS Forced Main Line	_____ 
Designated SS Forced Main Line (S.U.E.*)	_____ 

MISCELLANEOUS:

Utility Pole	_____ 
Utility Pole with Base	_____ 
Utility Located Object	_____ 
Utility Traffic Signal Box	_____ 
Utility Unknown U/G Line	_____ 
U/G Tank; Water, Gas, Oil	_____ 
A/G Tank; Water, Gas, Oil	_____ 
U/G Test Hole (S.U.E.*)	_____ 
Abandoned According to Utility Records	_____ 
End of Information	_____ 

PAVEMENT SCHEDULE	
C1	PROP. APPROX. 3.0" ASPHALT CONCRETE SURFACE COURSE, TYPE SF9.5A, AT AN AVERAGE RATE OF 165 LBS. PER SQ. YARD IN EACH OF TWO LAYERS.
C2	PROP. APPROX. 3.75" ASPHALT CONCRETE SURFACE COURSE, TYPE SF9.5A, AT AN AVERAGE RATE OF 206.25 LBS. PER SQ. YARD IN EACH OF TWO LAYERS.
D	PROP. APPROX. 2.5" ASPHALT CONCRETE INTERMEDIATE COURSE, TYPE I19.0B, AT AN AVERAGE RATE OF 285 LBS. PER SQ. YD.
D1	PROP. VAR. DEPTH ASPHALT CONCRETE INTERMEDIATE COURSE, TYPE I19.0B, AT AN AVERAGE RATE OF 114 LBS. PER SQ. YD. PER 1" DEPTH, TO BE PLACED IN LAYERS NOT LESS THAN 2 1/2" IN DEPTH OR GREATER THAN 4" IN DEPTH.
E	PROP. APPROX. 4" ASPHALT CONCRETE BASE COURSE, TYPE B25.0B, AT AN AVERAGE RATE OF 456 LBS. PER SQ. YARD.
E1	PROP. VARIABLE DEPTH ASPHALT CONCRETE BASE COURSE, TYPE B25.0B AT AN AVERAGE RATE OF 114 LBS. PER SQ. YARD PER INCH DEPTH, TO BE PLACED IN LAYERS NOT GREATER THAN 5.5" IN DEPTH OR LESS THAN 3" IN DEPTH.
J	PROP. 6" AGGREGATE BASE COURSE
T	EARTH MATERIAL
U	EXISTING PAVEMENT
W	WEDGING (SEE DETAIL)

ALL PAVEMENT EDGE SLOPES ARE 1:1 UNLESS SHOWN OTHERWISE

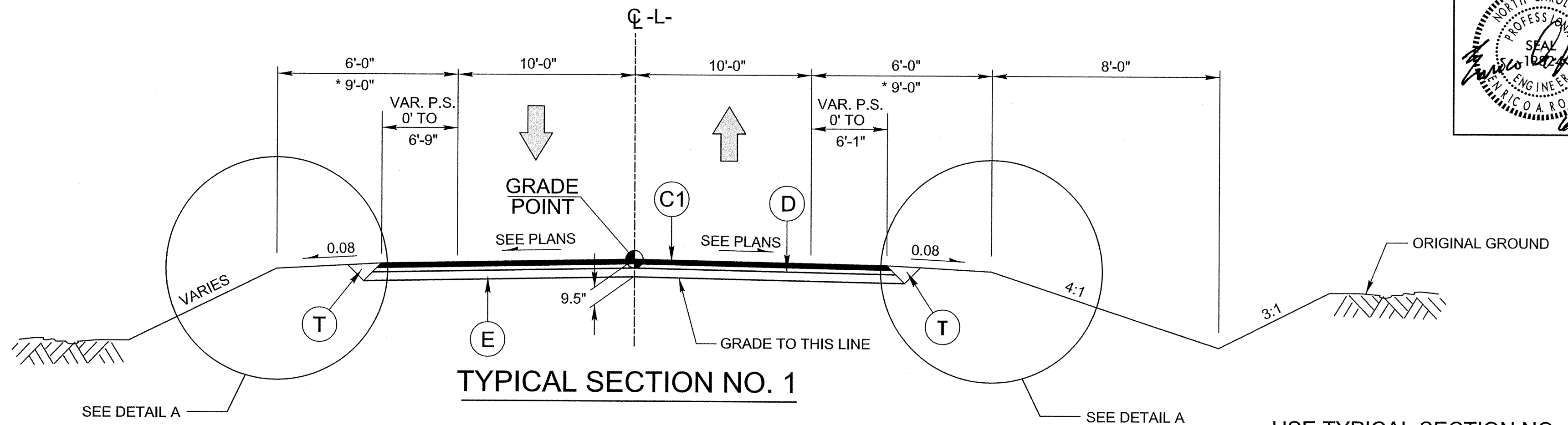

USE TYPICAL SECTION NO. 1 FROM:
 -L- STA. 14+40.00 TO -L- STA. 15+76.70 (BEGIN BRIDGE)
 -L- STA. 16+16+99.30 (END BRIDGE) TO -L- STA. 18+30.00

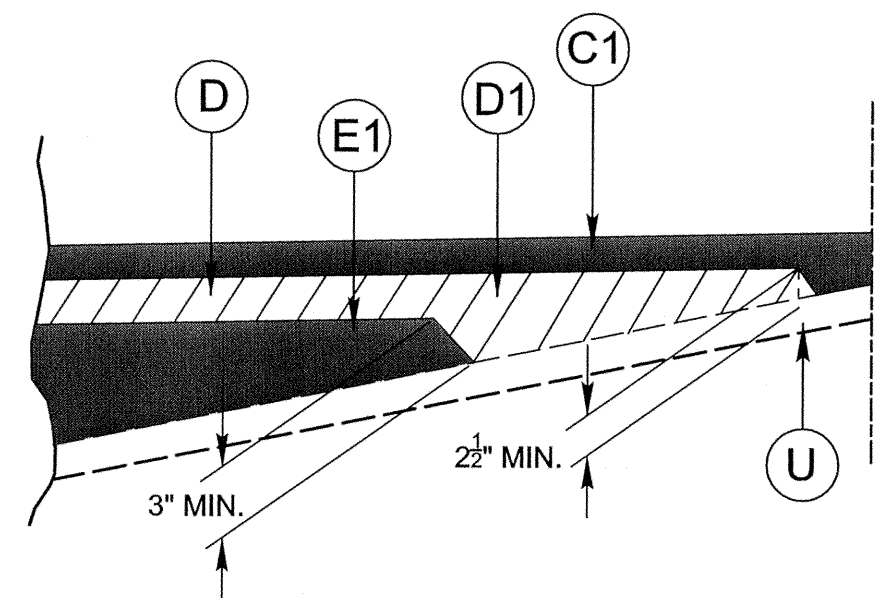

DETAIL SHOWING METHOD OF WEDGING
 SEE TYPICAL SECTIONS

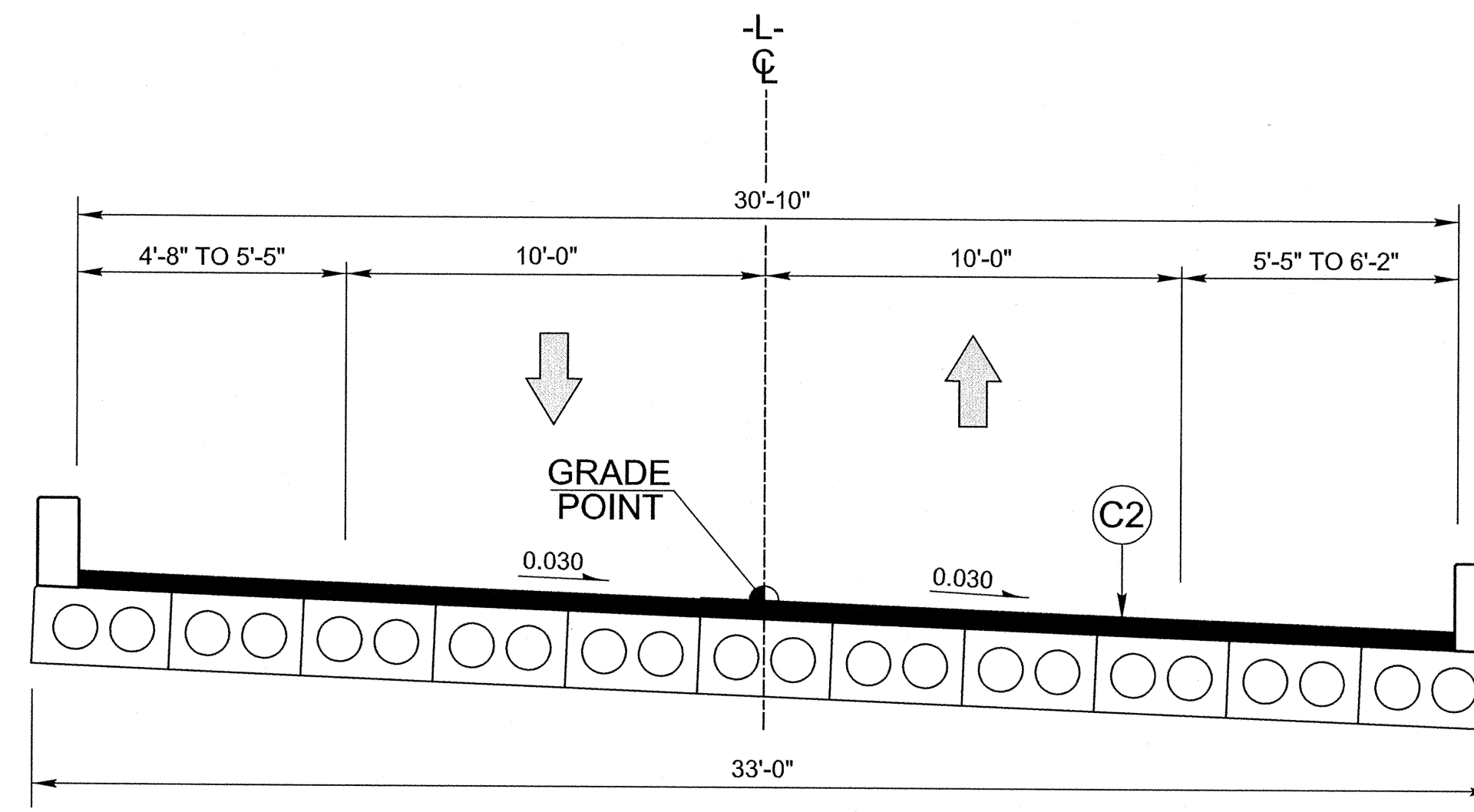

USE TYPICAL SECTION NO. 2 FROM:
 -L- STA. 15+76.70 TO -L- STA. 16+99.30

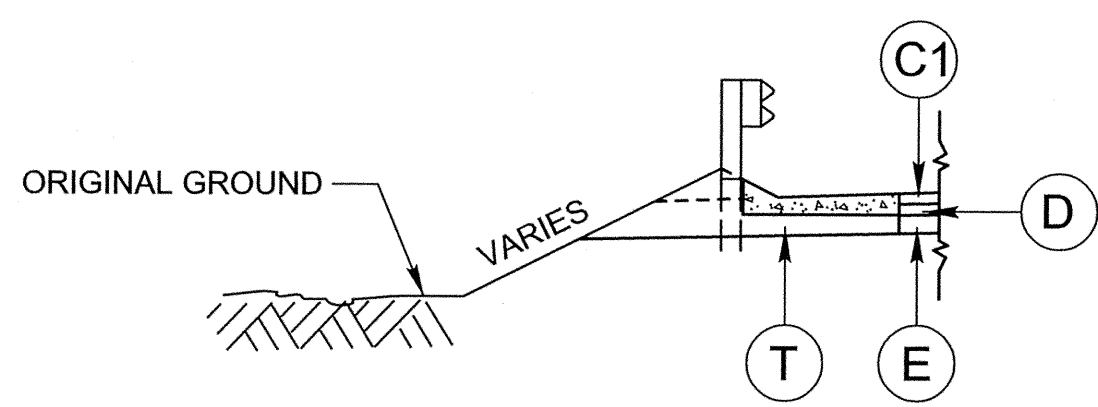

DETAIL A
 SHOULDER BERM GUTTER LOCATIONS
 -L- STA. 17+06.5 TO -L- STA. 17+36.5 RT

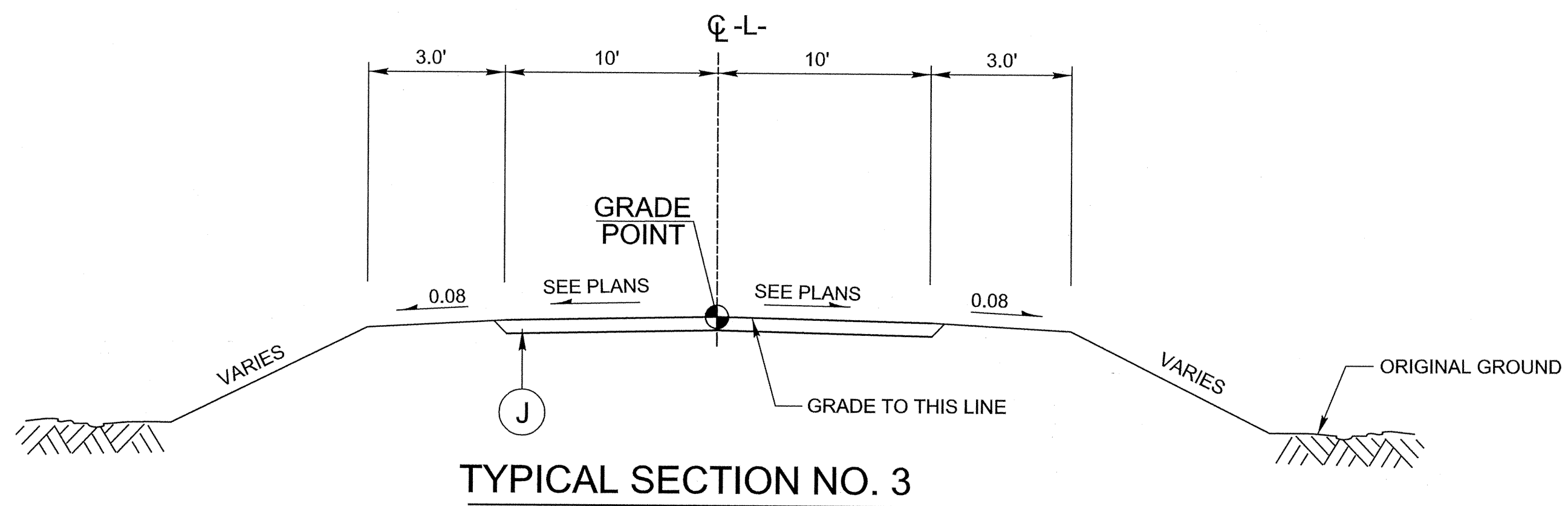

USE TYPICAL SECTION NO. 3 FROM:
 -L- STA. 11+00.00 TO -L- STA. 14+40.00
 -L- STA. 18+30.00 TO -L- STA. 23+50.00

NOTES: * SHOULDER WIDTH INCREASED 3' WITH THE USE OF GUARDRAIL

REVISIONS

\$\$\$\$DATE\$\$\$\$
 \$\$\$SYTIME\$\$\$
 \$\$\$SYTIME\$\$\$

Note: Approximate quantities only. Unclassified Excavation, Borrow Excavation, Shoulder Borrow, Fine Grading, Clearing and Grubbing, Breaking of Existing Pavement, and Removal of Existing Pavement will be paid for at the contract lump sum price for "Grading."

STATE OF NORTH CAROLINA
DIVISION OF HIGHWAYS

CROSS-SECTION SUMMARY
IN CUBIC YARDS

NOTE: EMBANKMENT COLUMN DOES NOT INCLUDE BACKFILL FOR UNDERCUT

STATION	UNCLASSIFIED EXCAVATION	EMBANK.	UNDERCUT
-L- STA. 10+50.00	0	0	0
-L- STA. 11+00.00	0	0	0
-L- STA. 11+50.00	25	1	0
-L- STA. 12+00.00	48	4	0
-L- STA. 12+50.00	120	6	0
-L- STA. 13+00.00	157	11	0
-L- STA. 13+50.00	148	15	0
-L- STA. 14+00.00	145	17	0
-L- STA. 14+50.00	80	62	0
-L- STA. 15+00.00	30	79	0
-L- STA. 15+50.00	47	57	0
-L- STA. 16+00.00	235	20	0
-L- STA. 16+50.00	0	0	0
-L- STA. 17+00.00	70	8	0
-L- STA. 17+50.00	20	143	0
-L- STA. 18+00.00	50	129	0
-L- STA. 18+50.00	67	123	0
-L- STA. 19+00.00	35	147	0
-L- STA. 19+50.00	14	176	0
-L- STA. 20+00.00	21	160	0
-L- STA. 20+50.00	33	110	0
-L- STA. 21+00.00	21	86	0
-L- STA. 21+50.00	4	68	0
-L- STA. 22+00.00	0	46	0
-L- STA. 22+50.00	3	26	0
-L- STA. 23+00.00	14	14	0
-L- STA. 23+50.00	21	6	0
-L- STA. 24+00.00	0	0	0

02/03/98

PROJ. REFERENCE NO.	SHEET NO.	TOTAL SHEETS
17BP.2.R.24	X-3	10
55 60 65 70 75		

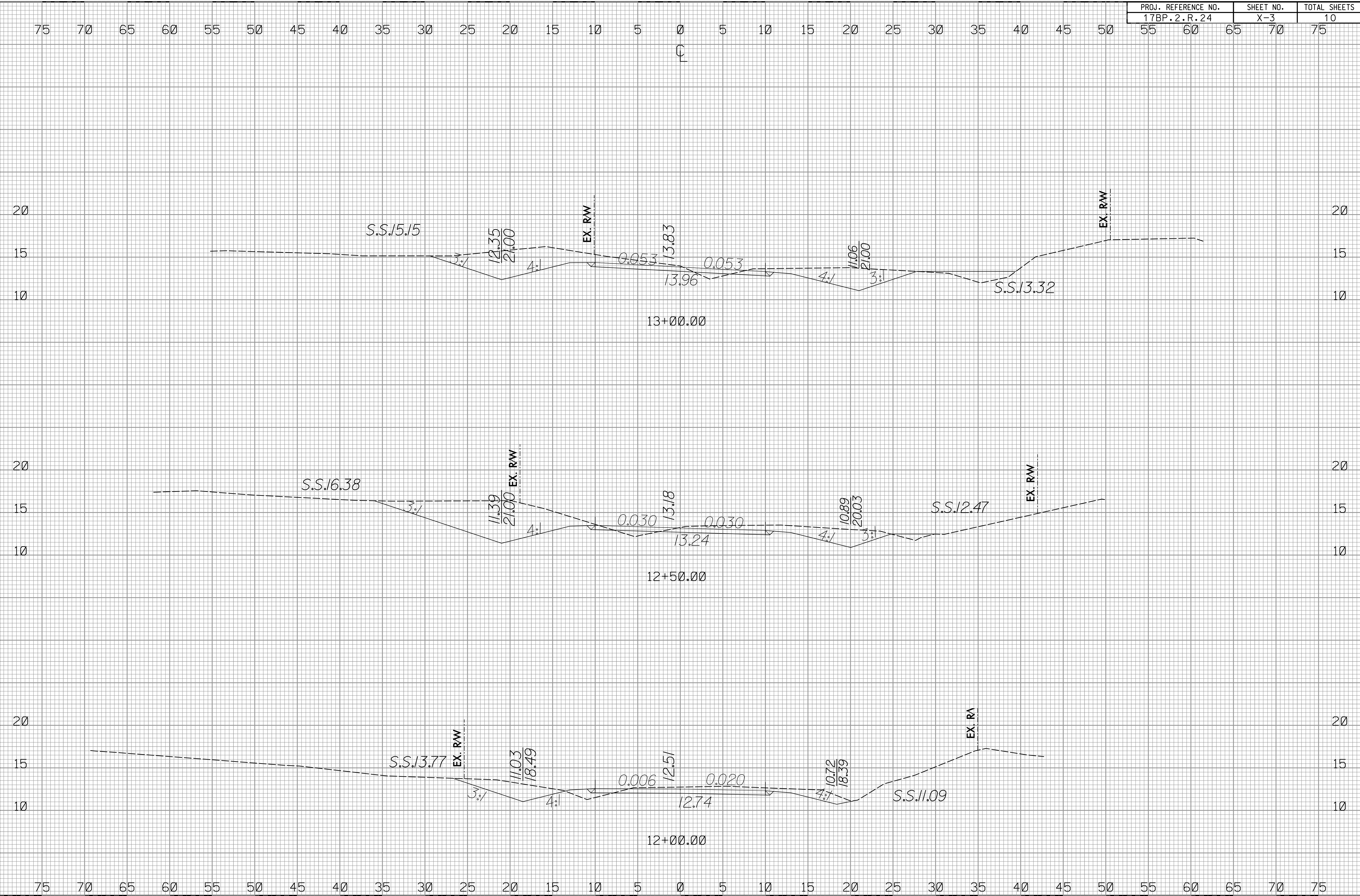

11/07/98 AM 10:24:00 9_r.dwg - xpl.dgn

02/03/98

PROJ. REFERENCE NO.	SHEET NO.	TOTAL SHEETS
17BP.2.R.24	X-4	10
55	60	65
70	75	

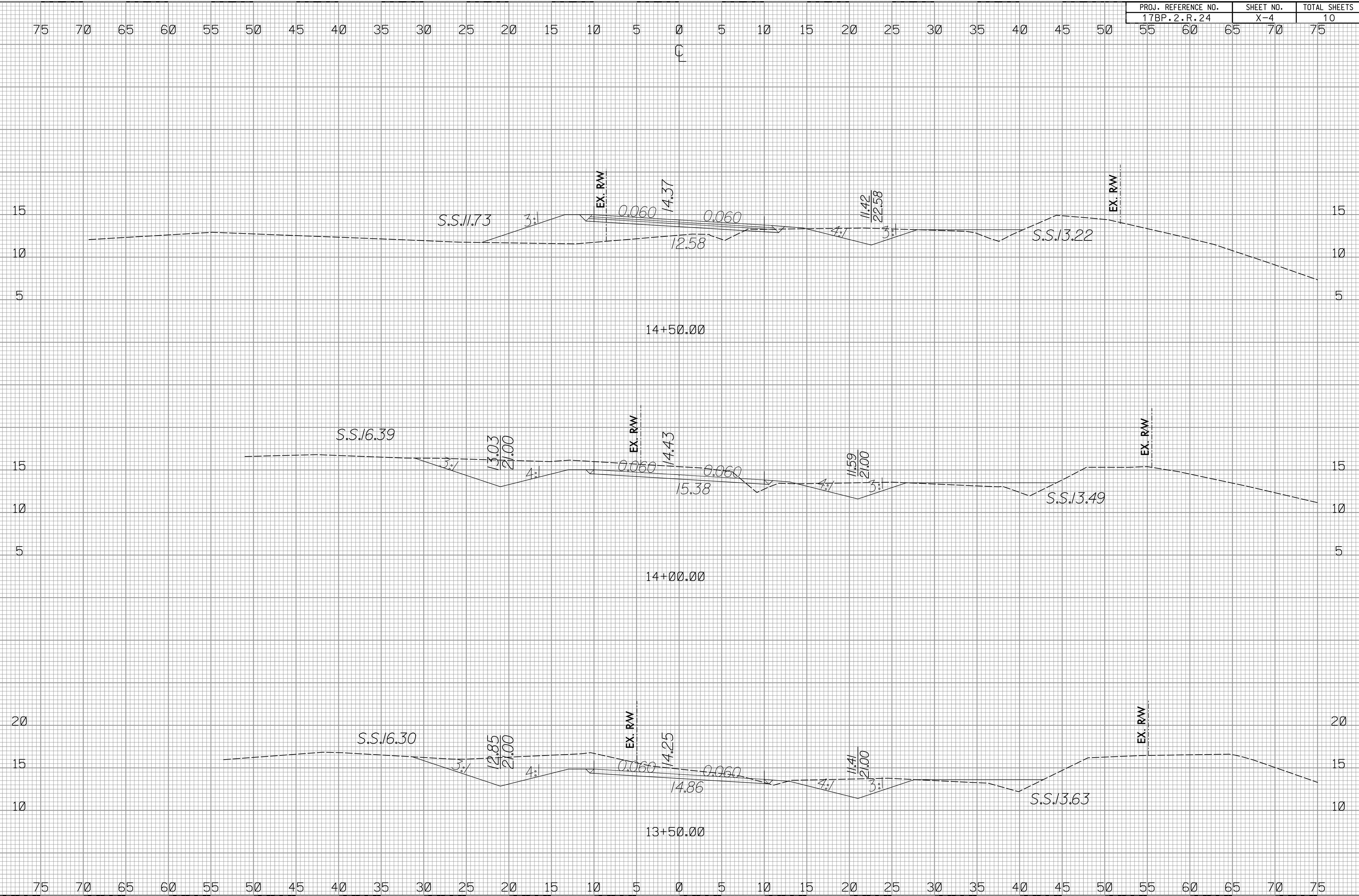

11:08:00 AM C:\240009_1_rdy_xpl.dgn

PROJ. REFERENCE NO.	SHEET NO.	TOTAL SHEETS
17BP.2.R.24	X-5	10

02/03/98

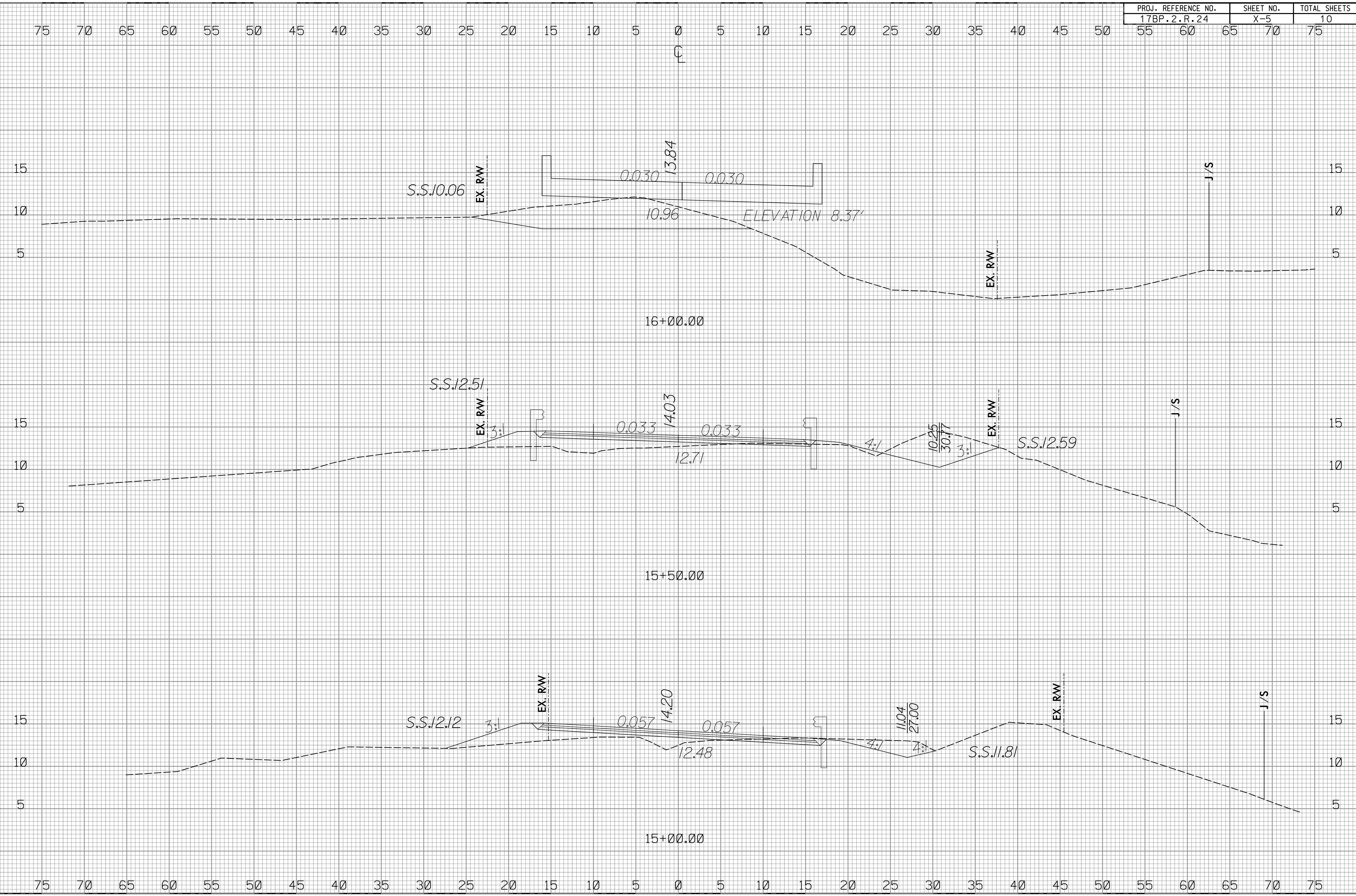

\\08:03 AM 02/24/00 09_24_00.dwg
 \$\$\$
 \$\$\$

02/03/98

PROJ. REFERENCE NO.	SHEET NO.	TOTAL SHEETS
17BP.2.R.24	X-6	10

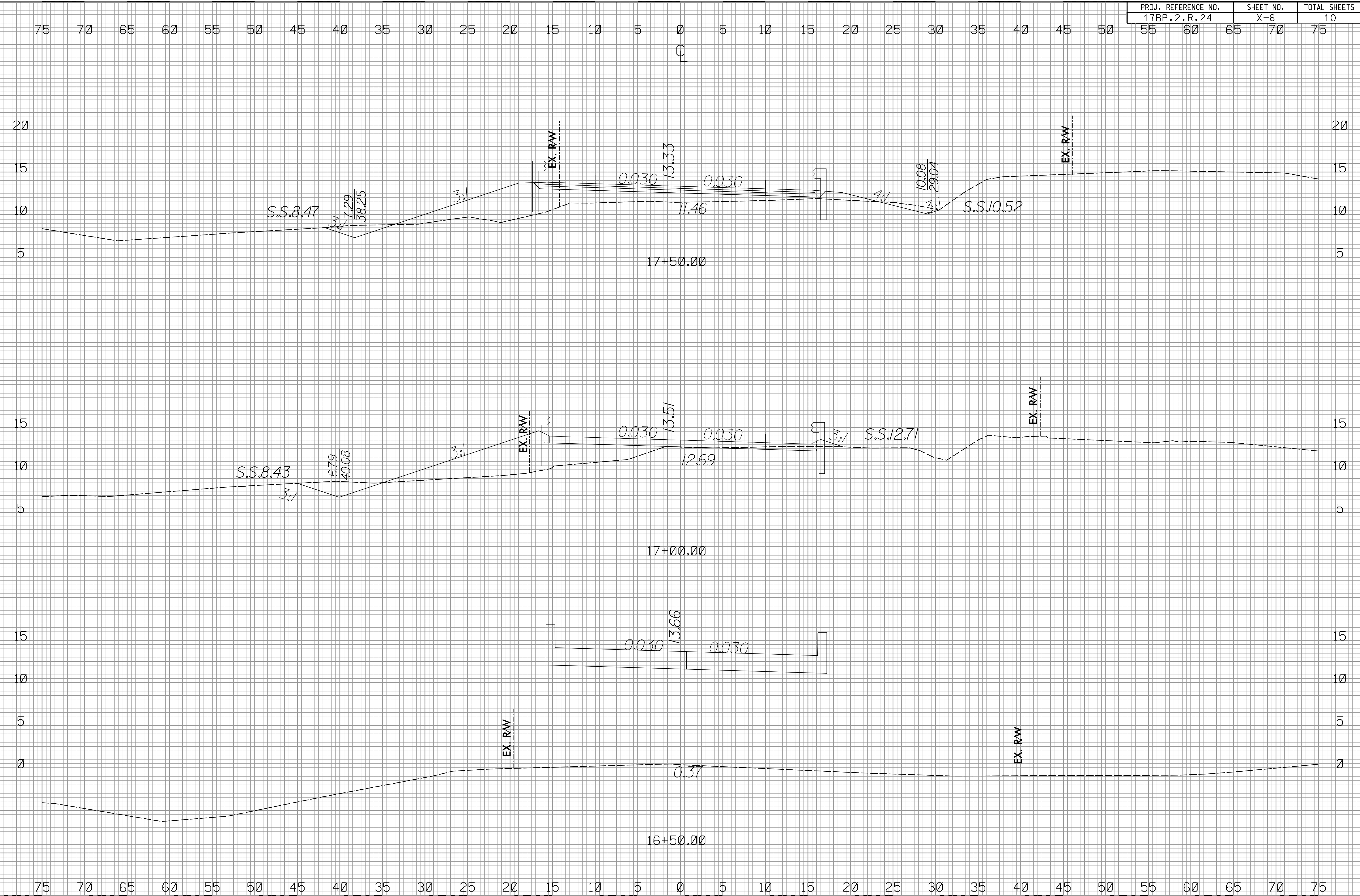

\\08:05 AM 02/24/00 09_17.dwg - xpl.dwg

02/03/98

PROJ. REFERENCE NO.	SHEET NO.	TOTAL SHEETS
17BP.2.R.24	X-8	10
55 60 65 70 75		

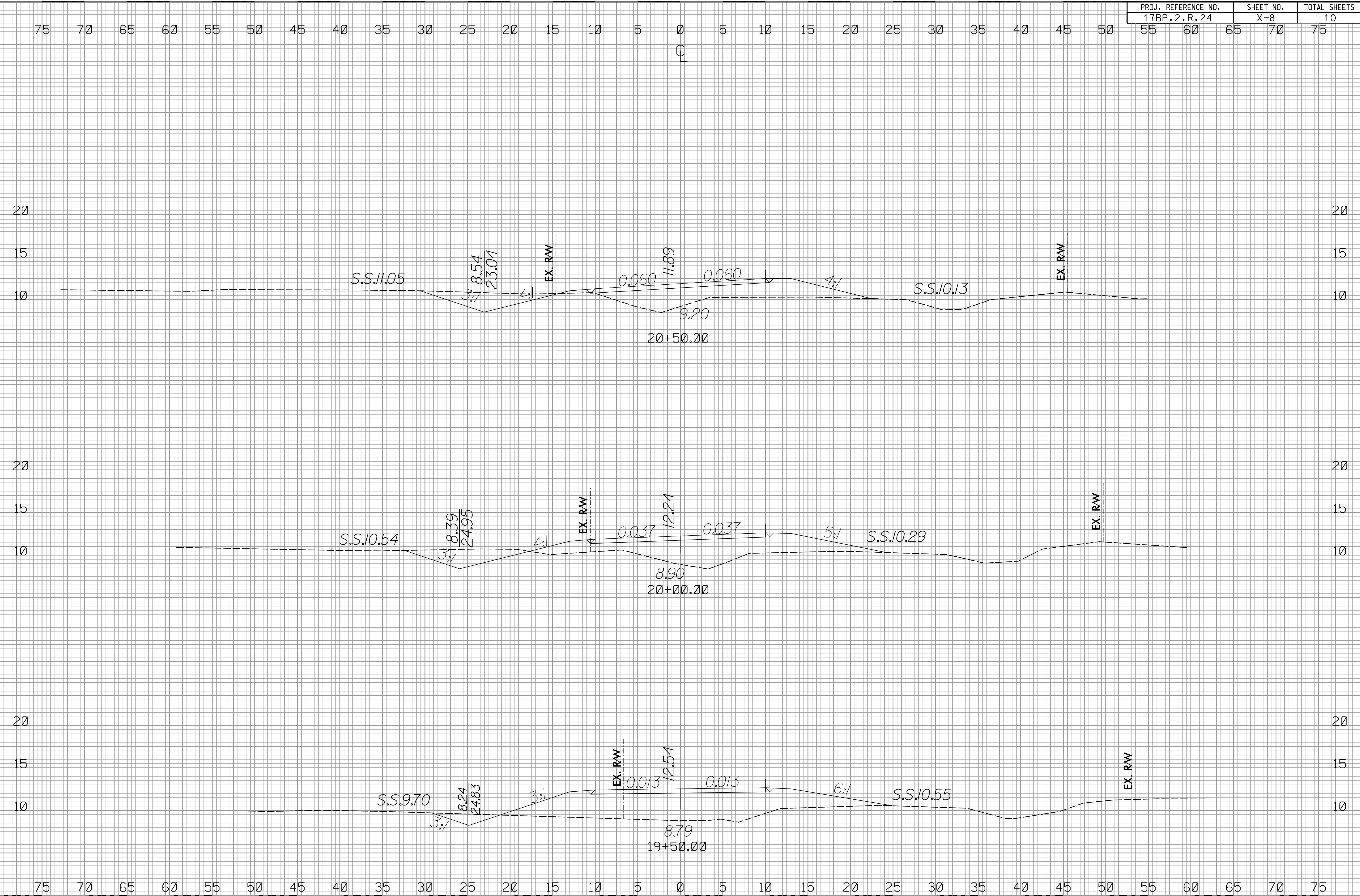

\\f08h11\AW\GC\240009_r.dj...xp1.dgn

02/03/98

PROJ. REFERENCE NO.	SHEET NO.	TOTAL SHEETS
17BP.2.R.24	X-9	10
55	60	65
70	75	

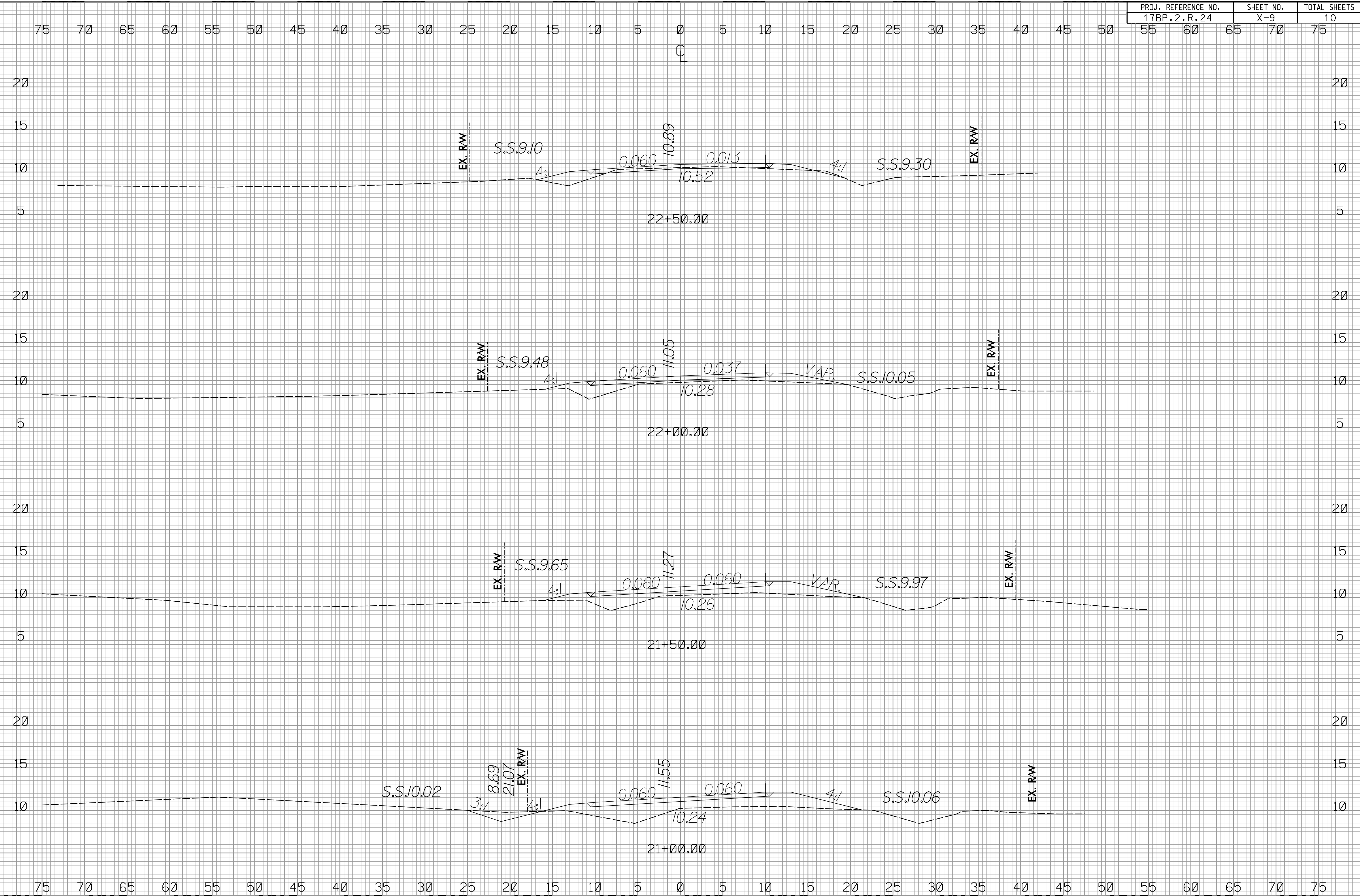

\\f0813 AM\GC\240009_rdy_xpl.dgn

02/03/98

PROJ. REFERENCE NO.	SHEET NO.	TOTAL SHEETS
17BP.2.R.24	X-10	10

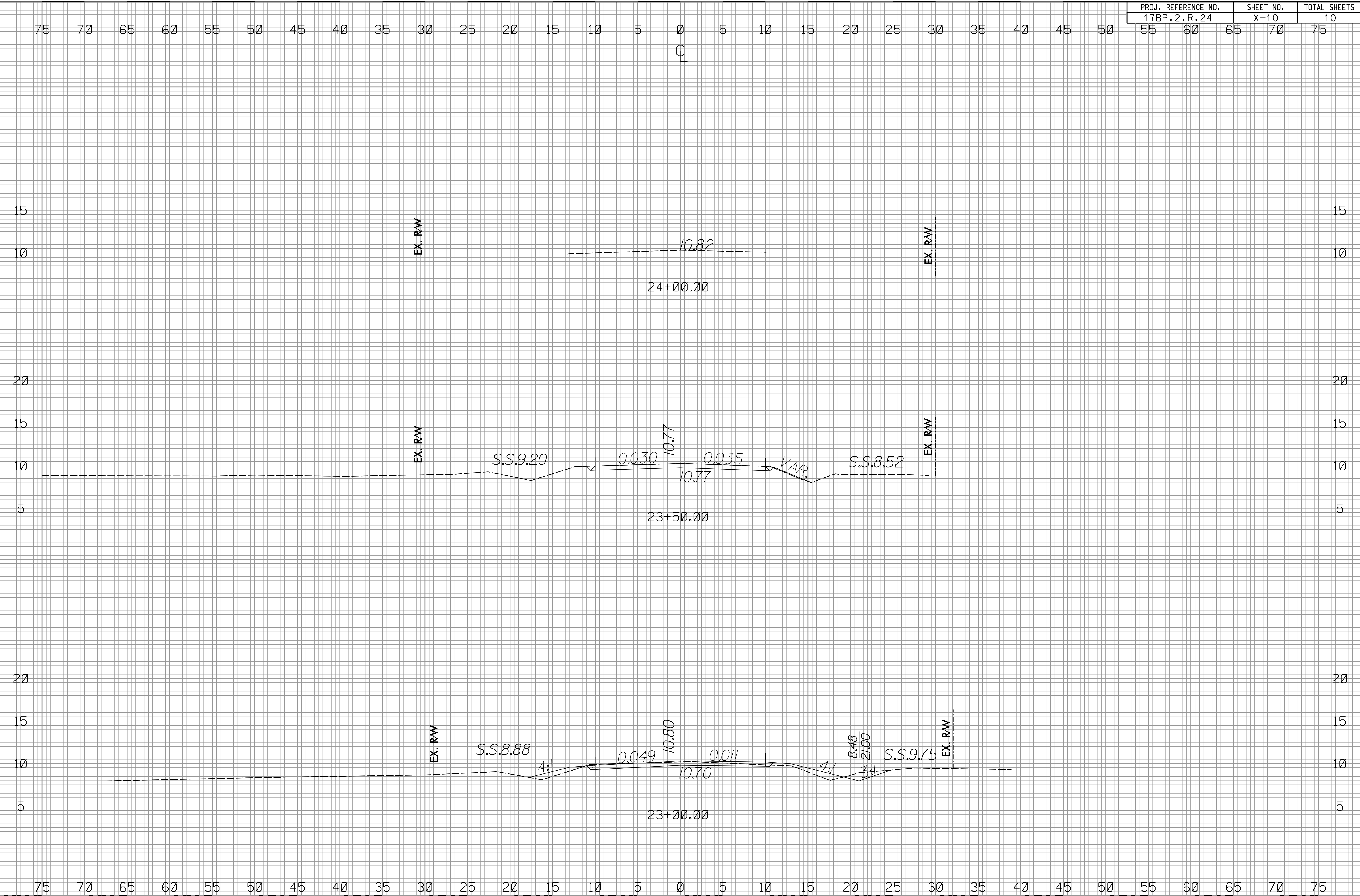

\\f0816 AM\CG\240000\rdj_xpl.dgn