

TYPE 1A

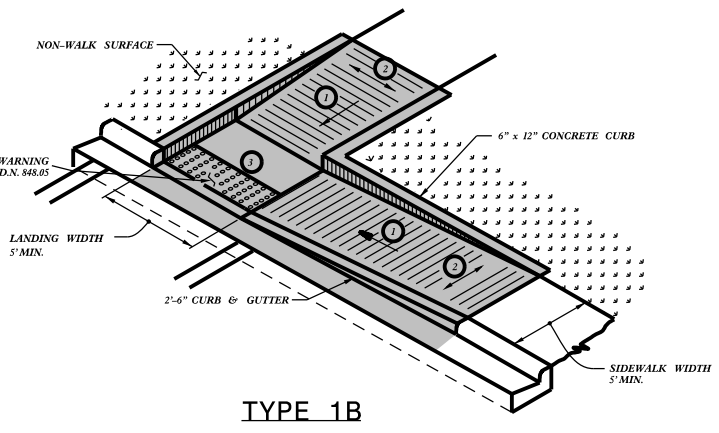

TYPE 1B

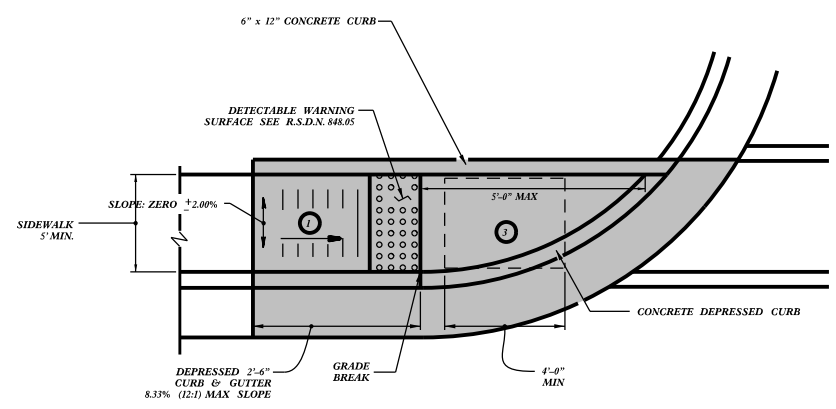

TYPE 1

PAY LIMITS FOR 1 CURB RAMP

- 1 8.33% (12:1) MAX RAMP SLOPE
- 2 CROSS SLOPE: 2.00%
- 3 CURB RAMP REQUIRE A (4'-0") MINIMUM LANDING WITH A MAXIMUM CROSS SLOPE AND LONGITUDINAL SLOPE OF 2.00% WHERE PEDESTRIANS PERFORM TURNING MANEUVERS. SLOPE TO DRAIN TO CURB.

REFER TO ROADWAY STANDARD DRAWING NUMBER 848.05 SHEET 3 OF 3 FOR ALL RAMP NOTES

CURB RAMP DETAIL

5/14/98
 1
 2
 3
 4
 5
 6
 7
 8
 9
 10
 11
 12
 13
 14
 15
 16
 17
 18
 19
 20
 21
 22
 23
 24
 25
 26
 27
 28
 29
 30
 31
 32
 33
 34
 35
 36
 37
 38
 39
 40
 41
 42
 43
 44
 45
 46
 47
 48
 49
 50
 51
 52
 53
 54
 55
 56
 57
 58
 59
 60
 61
 62
 63
 64
 65
 66
 67
 68
 69
 70
 71
 72
 73
 74
 75
 76
 77
 78
 79
 80
 81
 82
 83
 84
 85
 86
 87
 88
 89
 90
 91
 92
 93
 94
 95
 96
 97
 98
 99
 100

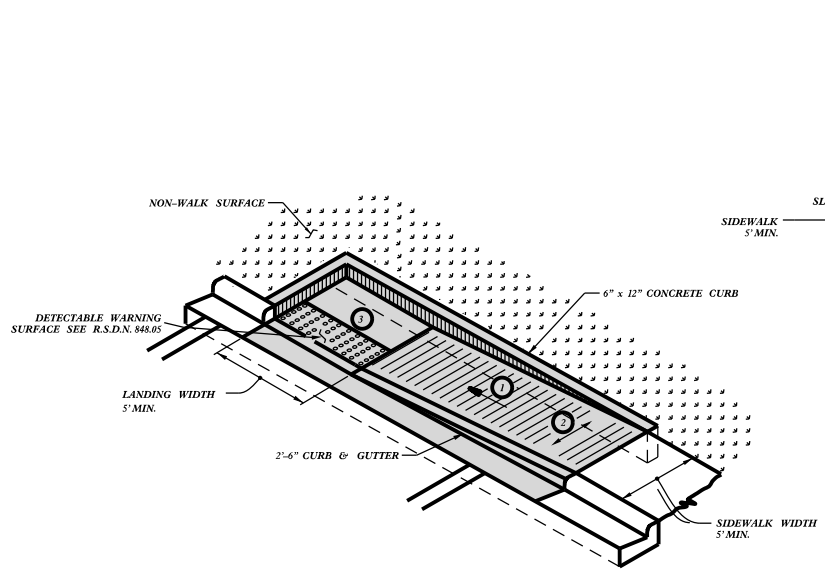

TYPE 1A

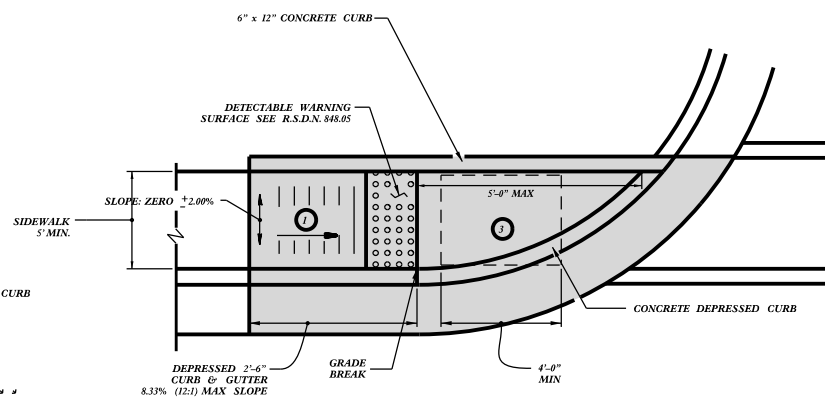

TYPE 1

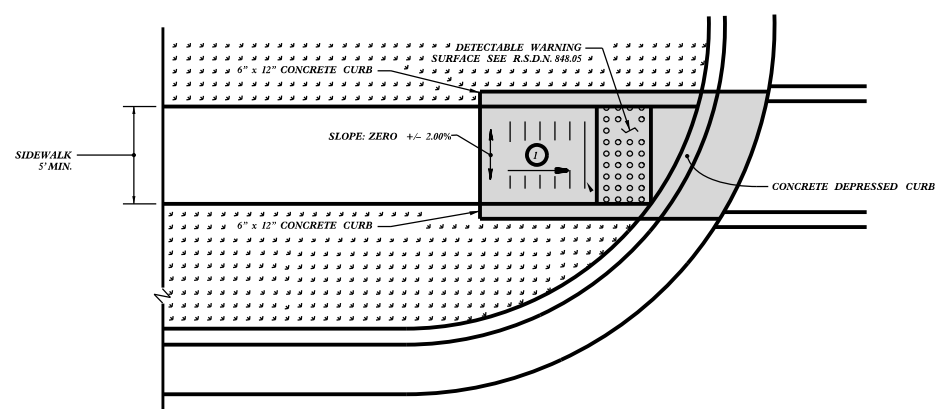

TYPE 1 Modified

- ① 8.33% (12:1) MAX RAMP SLOPE
- ② CROSS SLOPE: 2.00%
- ③ CURB RAMPS REQUIRE A (4'-0") MINIMUM LANDING WITH A MAXIMUM CROSS SLOPE AND LONGITUDINAL SLOPE OF 2.00% WHERE PEDESTRIANS PERFORM TURNING MANEUVERS. SLOPE TO DRAIN TO CURB.

PAY LIMITS FOR 1 CURB RAMP

REFER TO ROADWAY STANDARD DRAWING NUMBER 848.05 SHEET 3 OF 3 FOR ALL RAMP NOTES

CURB RAMP DETAIL

PAY LIMITS FOR 1 CURB RAMP

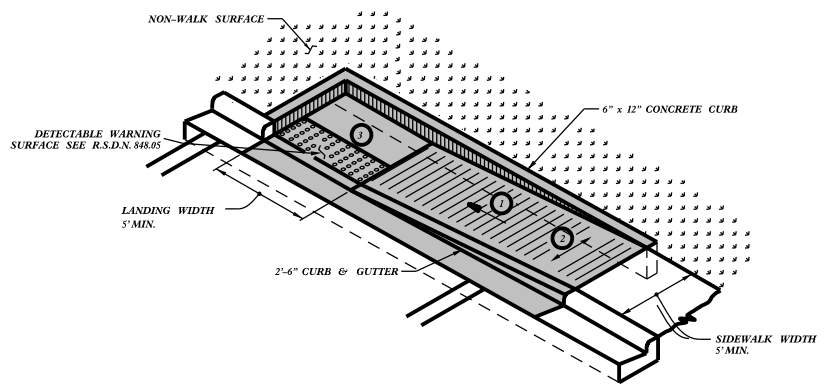

TYPE 1A

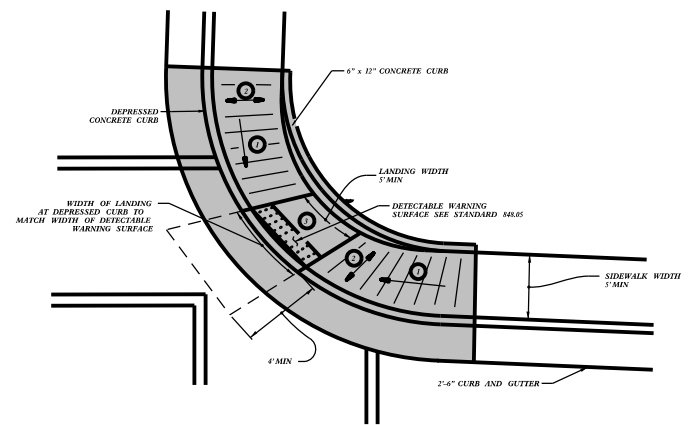

TYPE 2A

- 1 8.33% (12:1) MAX RAMP SLOPE
- 2 CROSS SLOPE: 2.00%
- 3 CURB RAMPS REQUIRE A (4'-0") MINIMUM LANDING WITH A MAXIMUM CROSS SLOPE AND LONGITUDINAL SLOPE OF 2.00% WHERE PEDESTRIANS PERFORM TURNING MANEUVERS. SLOPE TO DRAIN TO CURB.

REFER TO ROADWAY STANDARD DRAWING NUMBER 848.05 SHEET 3 OF 3 FOR ALL RAMP NOTES

CURB RAMP DETAIL

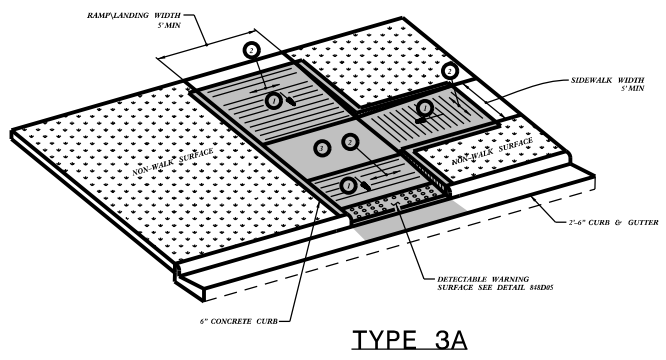

TYPE 3A

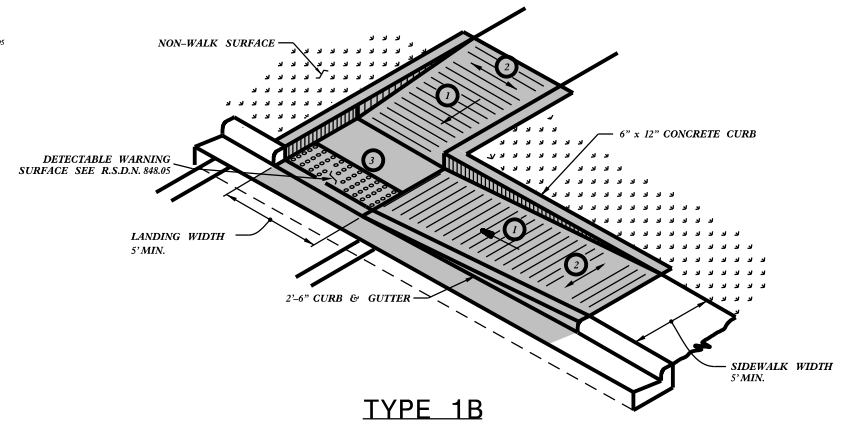

TYPE 1B

- ① 8.33% (12:1) MAX RAMP SLOPE
- ② CROSS SLOPE: 2.00%
- ③ CURB RAMPS REQUIRE A (4'-0") MINIMUM LANDING WITH A MAXIMUM CROSS SLOPE AND LONGITUDINAL SLOPE OF 2.00% WHERE PEDESTRIANS PERFORM TURNING MANEUVERS. SLOPE TO DRAIN TO CURB.

PAY LIMITS FOR 1 CURB RAMP

REFER TO ROADWAY STANDARD DRAWING NUMBER 848.05 SHEET 3 OF 3 FOR ALL RAMP NOTES

CURB RAMP DETAIL

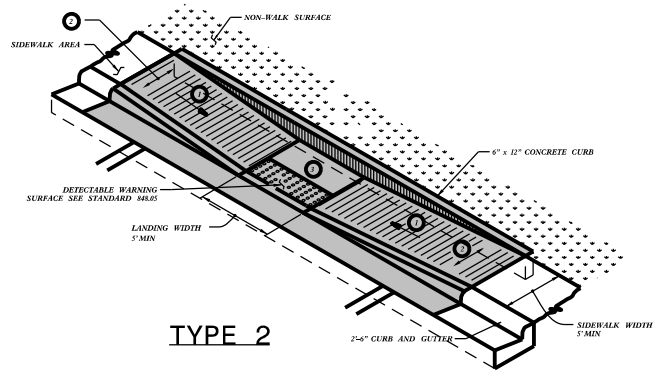

TYPE 2

PAY LIMITS FOR 1 CURB RAMP

- ① 8.33% (12:1) MAX RAMP SLOPE
- ② CROSS SLOPE: 2.00%
- ③ CURB RAMPS REQUIRE A (4'-0") MINIMUM LANDING WITH A MAXIMUM CROSS SLOPE AND LONGITUDINAL SLOPE OF 2.00% WHERE PEDESTRIANS PERFORM TURNING MANEUVERS. SLOPE TO DRAIN TO CURB.

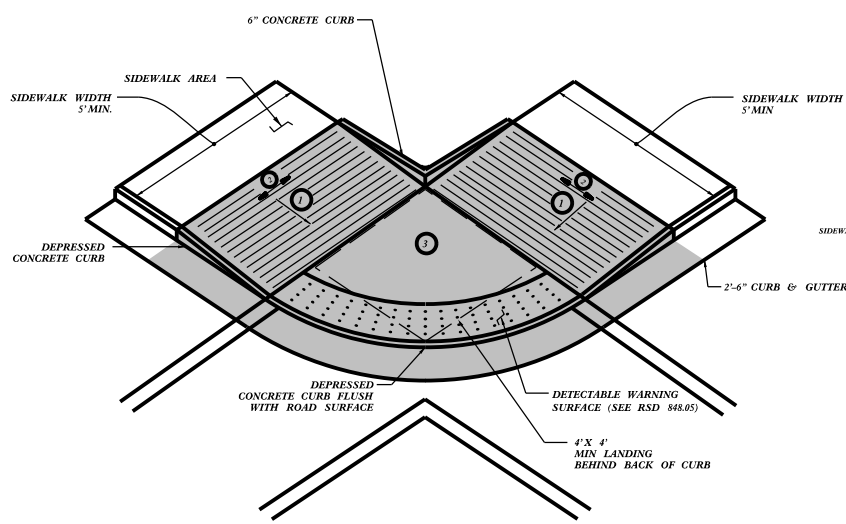

TYPE 2A

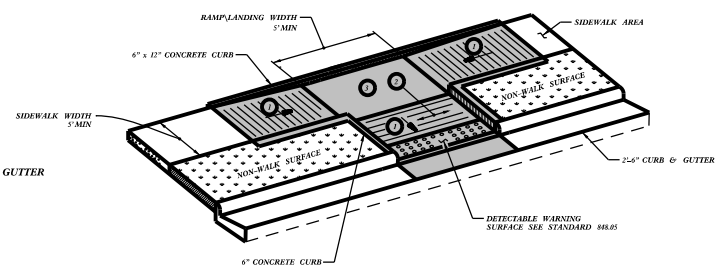

TYPE 3

REFER TO ROADWAY STANDARD DRAWING NUMBER 848.05 SHEET 3 OF 3 FOR ALL RAMP NOTES

CURB RAMP DETAIL

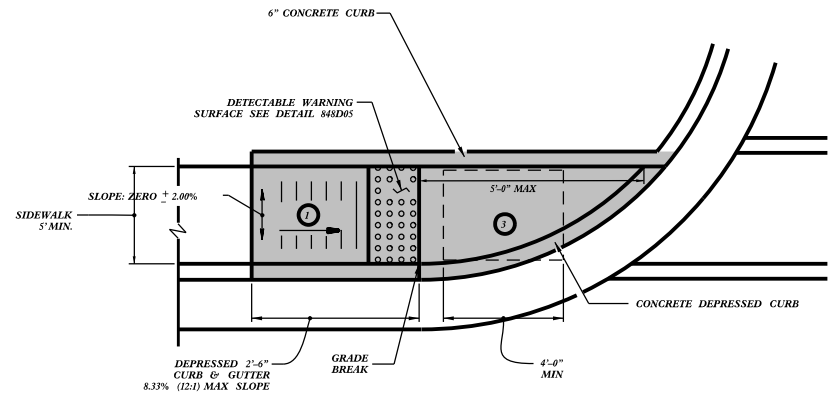

TYPE I

-L- STA. 14+57 RT, 15+04 RT, 15+64 RT, 16+16 RT,
19+74 RT, 20+04 RT, 21+23 LT, 21+76 LT,
33+04 LT, 33+36 LT, 38+26 LT, 38+78 LT

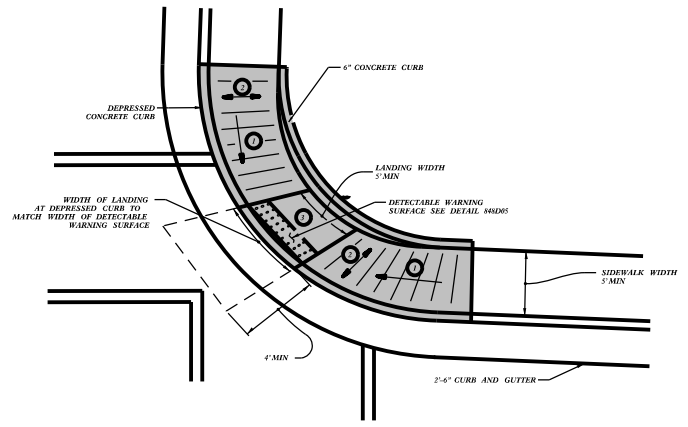

TYPE III

-L- STA. 14+16 RT, 27+40 RT, 27+75 RT, 32+06 LT,
32+57 LT, 35+13 LT, 35+57 LT, 50+17 LT,
50+05 RT, 50+89 LT, 51+03 RT

PAY LIMITS FOR CURB RAMP

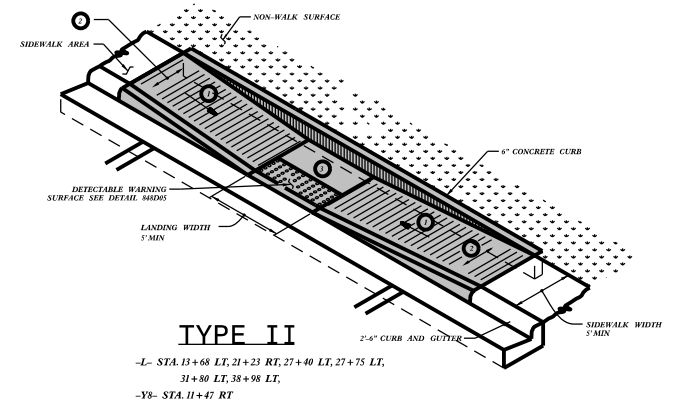

TYPE II

-L- STA. 13+68 LT, 21+23 RT, 27+40 LT, 27+75 LT,
31+80 LT, 38+98 LT,
-Y8- STA. 11+47 RT

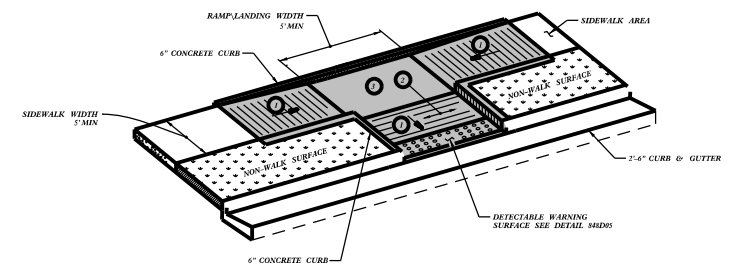

TYPE IV

-L- STA. 31+80 RT, 32+57 RT, 35+06 RT, 35+51 RT

- USE AT STATIONS INDICATED UNLESS OTHERWISE DIRECTED BY THE ENGINEER
- RAMP WIDTHS AND LENGTHS MAY BE ADJUSTED UPWARD AS DIRECTED BY THE ENGINEER

- 1 8.33% (12:1) MAX RAMP SLOPE
- 2 CROSS SLOPE: 2.00%
- 3 CURB RAMPs REQUIRE A (4'-0") MINIMUM LANDING WITH A MAXIMUM CROSS SLOPE AND LONGITUDINAL SLOPE OF 2.00% WHERE PEDESTRIANS PERFORM TURNING MANEUVERS. SLOPE TO DRAIN TO CURB.

CURB RAMP DETAIL

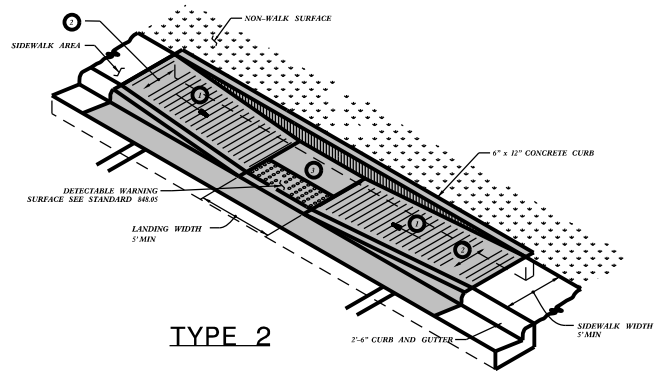

TYPE 2

PAY LIMITS FOR 1 OR 2 CURB RAMPS

- ① 8.33% (12:1) MAX RAMP SLOPE
- ② CROSS SLOPE: 2.00%
- ③ CURB RAMPS REQUIRE A (4'-0") MINIMUM LANDING WITH A MAXIMUM CROSS SLOPE AND LONGITUDINAL SLOPE OF 2.00% WHERE PEDESTRIANS PERFORM TURNING MANEUVERS. SLOPE TO DRAIN TO CURB.

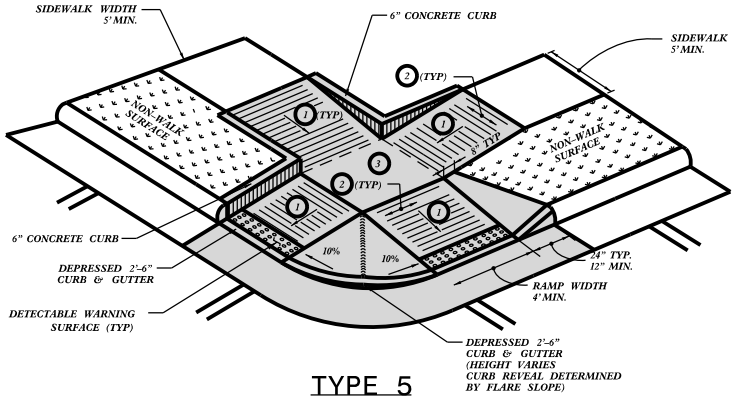

TYPE 5

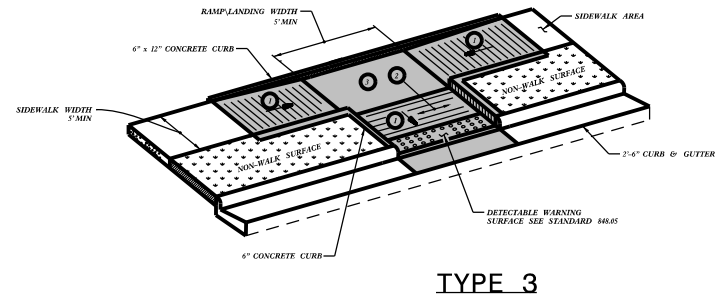

TYPE 3

REFER TO ROADWAY STANDARD DRAWING NUMBER 848.05 SHEET 3 OF 3 FOR ALL RAMP NOTES

CURB RAMP DETAIL

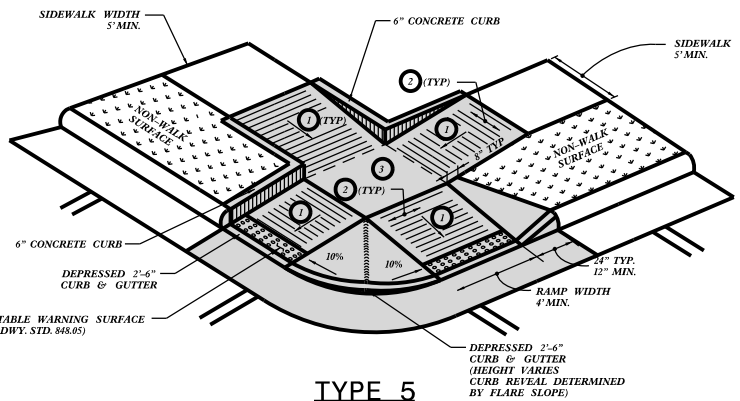
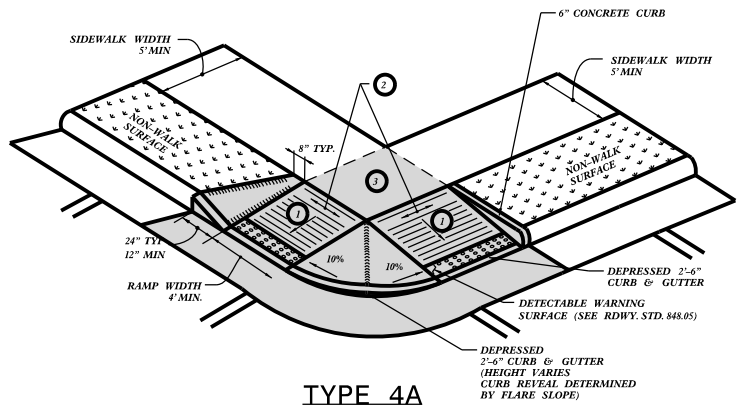
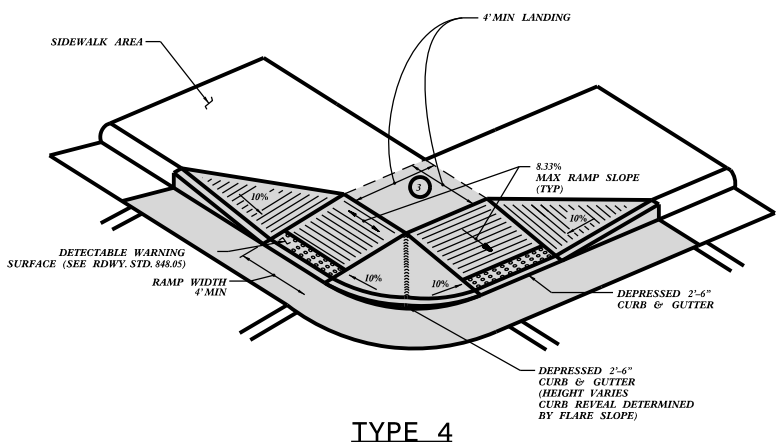

PAY LIMITS FOR 2 CURB RAMPS

- ① 8.33% (12:1) MAX RAMP SLOPE
- ② CROSS SLOPE: 2.00%
- ③ CURB RAMPS REQUIRE A (4'-0") MINIMUM LANDING WITH A MAXIMUM CROSS SLOPE AND LONGITUDINAL SLOPE OF 2.00% WHERE PEDESTRIANS PERFORM TURNING MANEUVERS. SLOPE TO DRAIN TO CURB.

REFER TO ROADWAY STANDARD DRAWING NUMBER 848.05 SHEET 3 OF 3 FOR ALL RAMP NOTES

CURB RAMP DETAIL

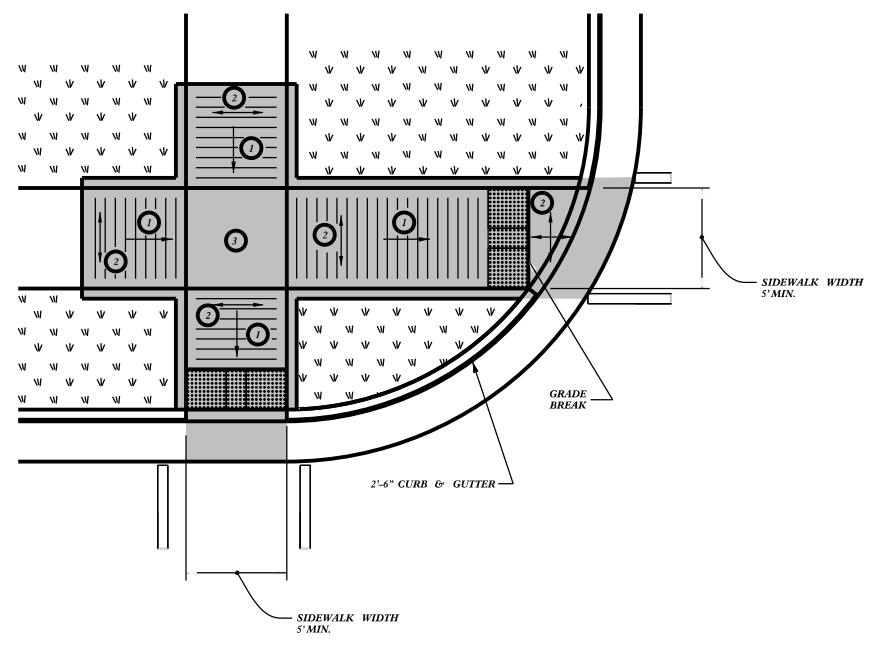

TYPE 5A

CURB RAMP DETAIL

PAY LIMITS FOR 1 CURB RAMP

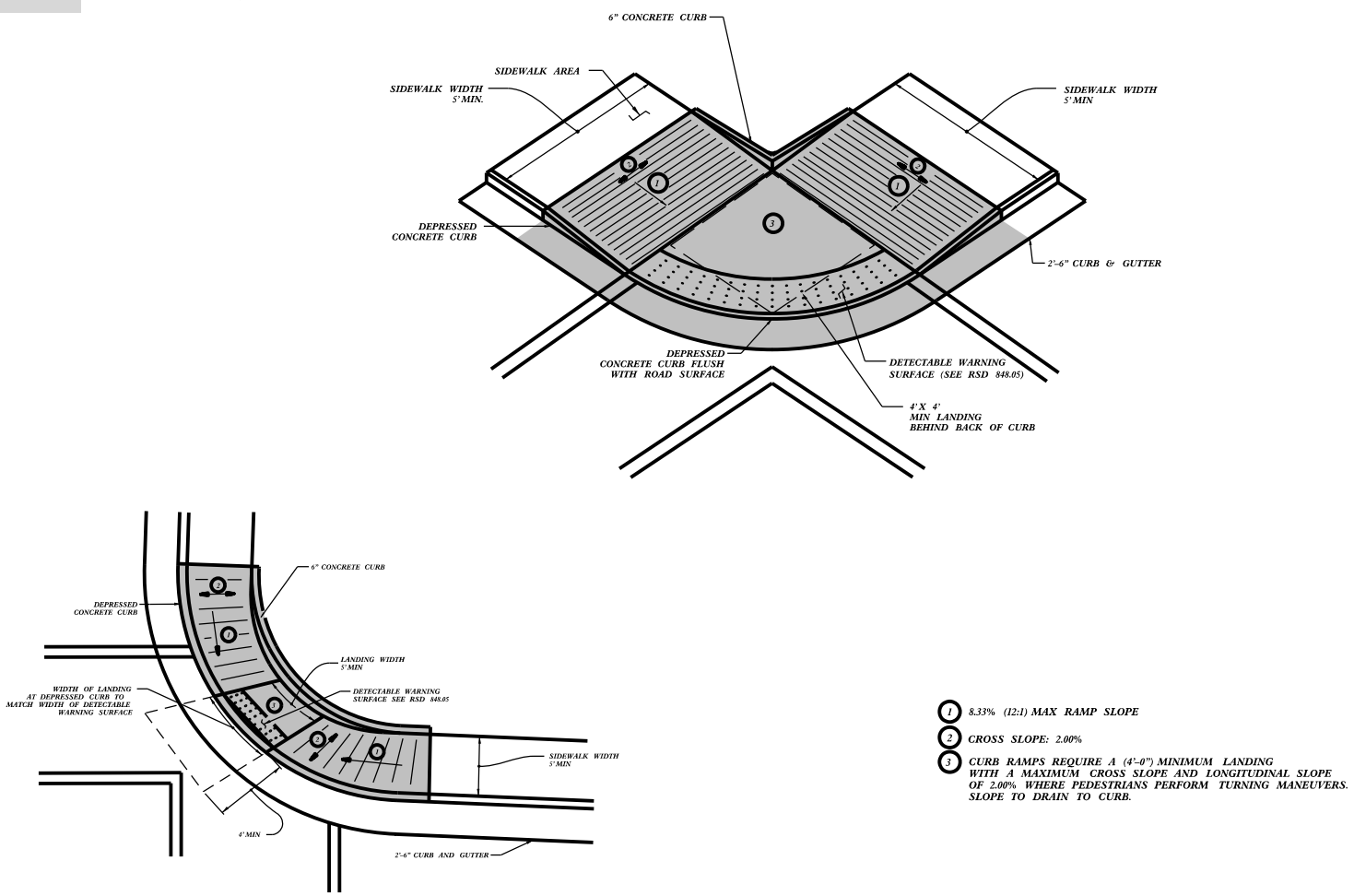

REFER TO ROADWAY STANDARD DRAWING NUMBER 848.05 SHEET 3 OF 3 FOR ALL RAMP NOTES

CURB RAMP DETAIL

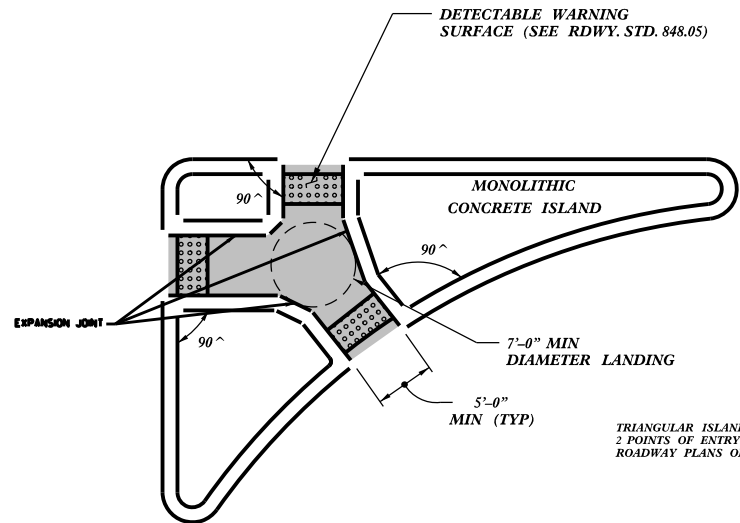

PAY LIMITS FOR 2 OR 3 CURB RAMPS
(CALCULATE BASED ON NUMBER OF
SETS OF TRUNCATED DOMES)

TRIANGULAR ISLANDS MAY BE CONSTRUCTED WITH ONLY
2 POINTS OF ENTRY AND EXIT AS SHOWN IN THE
ROADWAY PLANS OR AS DIRECTED BY THE ENGINEER.

TRIANGULAR ISLAND
WITH CUT THROUGH

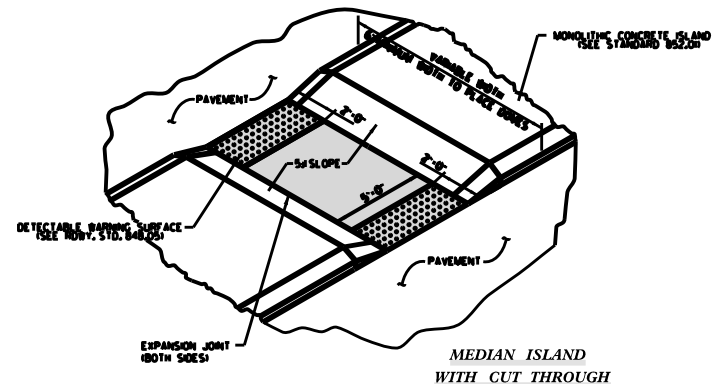

MEDIAN ISLAND
WITH CUT THROUGH

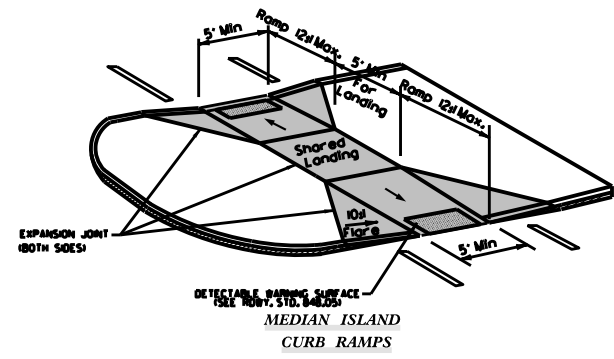

MEDIAN ISLAND
CURB RAMPS



CURB RAMP DETAIL

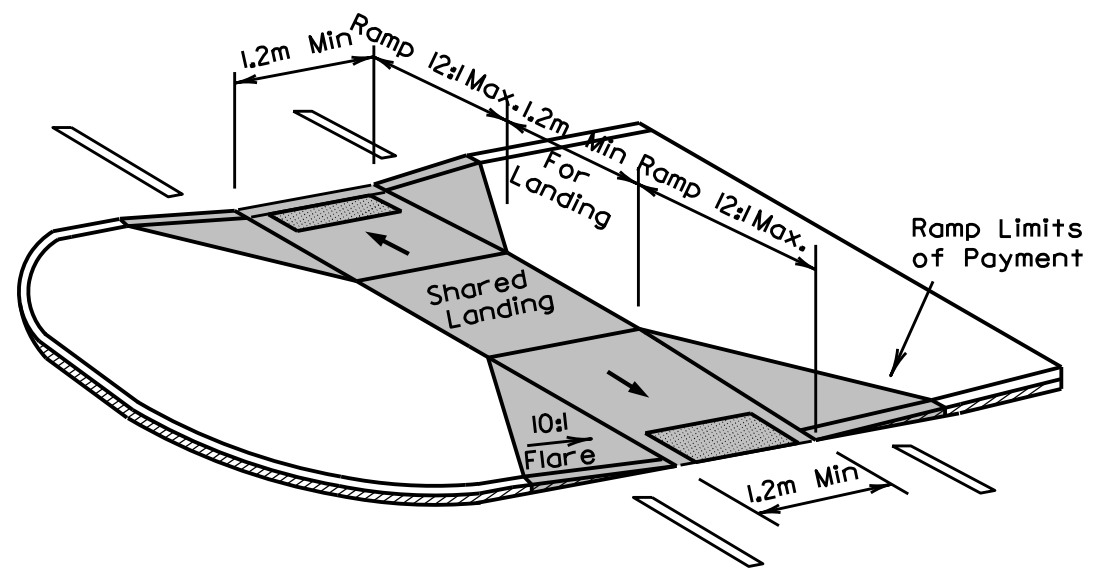

■ PAY LIMITS FOR 2 CURB RAMPS

MEDIAN ISLAND
CURB RAMPS

-SEE ROADWAY DETAIL DRAWING #48D05 FOR DETECTABLE WARNING SURFACE AND FOR RAMP NOTES.
-SEE ROADWAY STANDARD DRAWING 852.01 FOR CONCRETE ISLAND DIMENSIONS.

CURB RAMP DETAIL

- ① 8.33% (12:1) MAX RAMP SLOPE
- ② CROSS SLOPE: 2.00%
- ④ 8.00% MAX CHANGE IN GRADE BETWEEN ROAD SURFACE AND DRIVEWAY

PAY LIMITS FOR 1 CURB RAMP

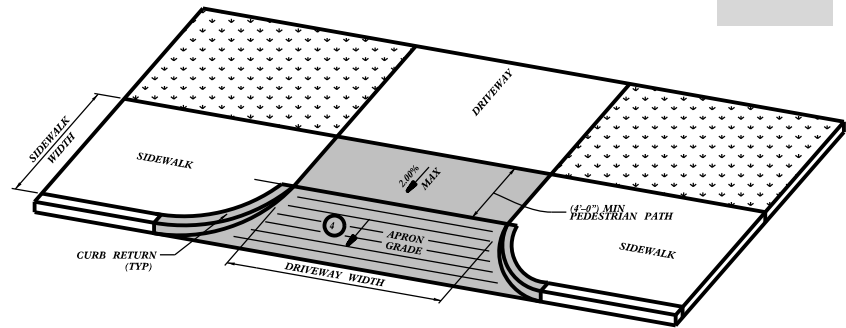

DRIVEWAY APRON
OPTION 1

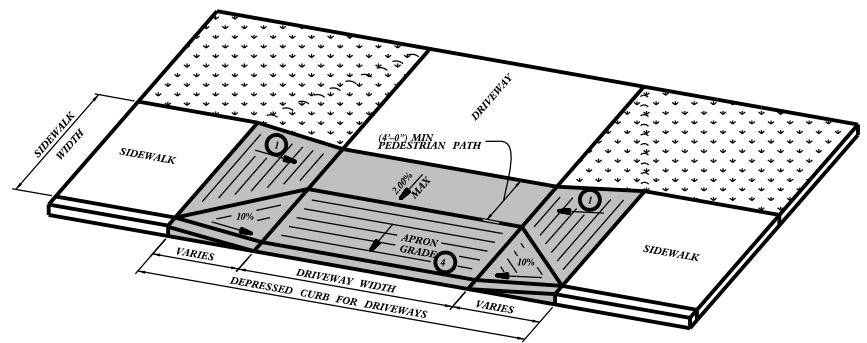

DRIVEWAY APRON
OPTION 2

-SEE ROADWAY DETAIL DRAWING 848.05 FOR DETECTABLE WARNING SURFACE AND FOR RAMP NOTES.
-SEE ROADWAY STANDARD DRAWING 848.02 FOR CONCRETE DRIVEWAYS.

CURB RAMP DETAIL