

**This electronic collection of documents is provided
for the convenience of the user
and is Not a Certified Document –**

**The documents contained herein were originally issued
and sealed by the individuals whose names and license
numbers appear on each page, on the dates appearing
with their signature on that page.**

**This file or an individual page
shall not be considered a certified document.**



09/28/19

See Sheet 1A For Index of Sheets
See Sheet 1B For Conventional Symbols

STATE OF NORTH CAROLINA
DIVISION OF HIGHWAYS

BRUNSWICK COUNTY

LOCATION: INTERSECTION OF NC 130 (WHITEVILLE RD.)
AT SR 1321 (LONGWOOD RD.)
TYPE OF WORK: GRADING, DRAINAGE, AND PAVING

STATE	STATE PROJECT REFERENCE NO.	SHEET NO.	TOTAL SHEETS
N.C.	W-5703Q	1	
STATE PROJ. NO.	F.A. PROJ. NO.	DESCRIPTION	
44849.1.17	HSIP-0130 (012)	P.E.	
44849.2.17	HSIP-0130 (012)	ROW	
44849.3.17	HSIP-0130 (012)	CONSTRUCTION	

TIP PROJECT: W-5703Q

CONTRACT: DC00337

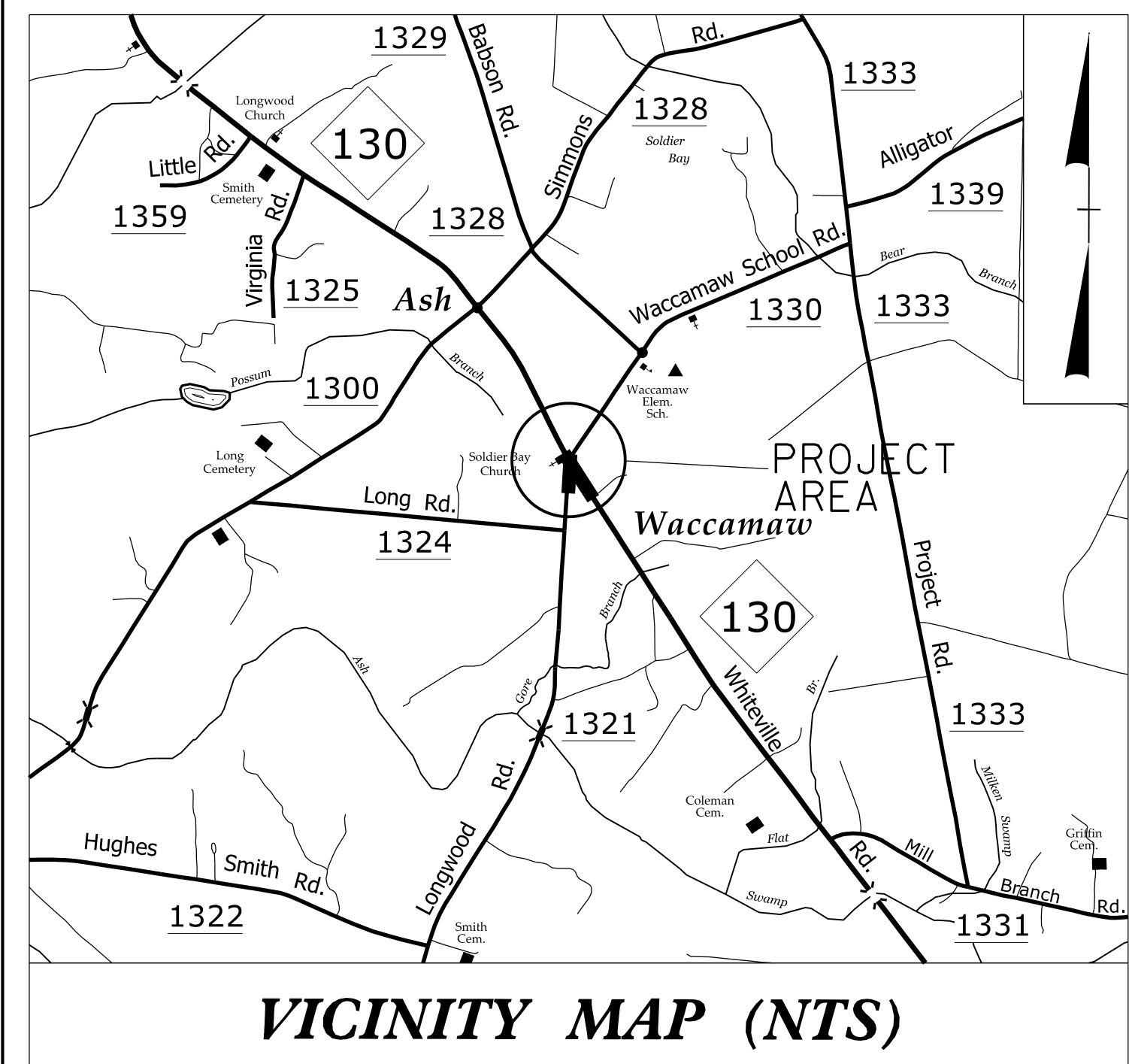

TO LONGWOOD

TO SHALLOTTE

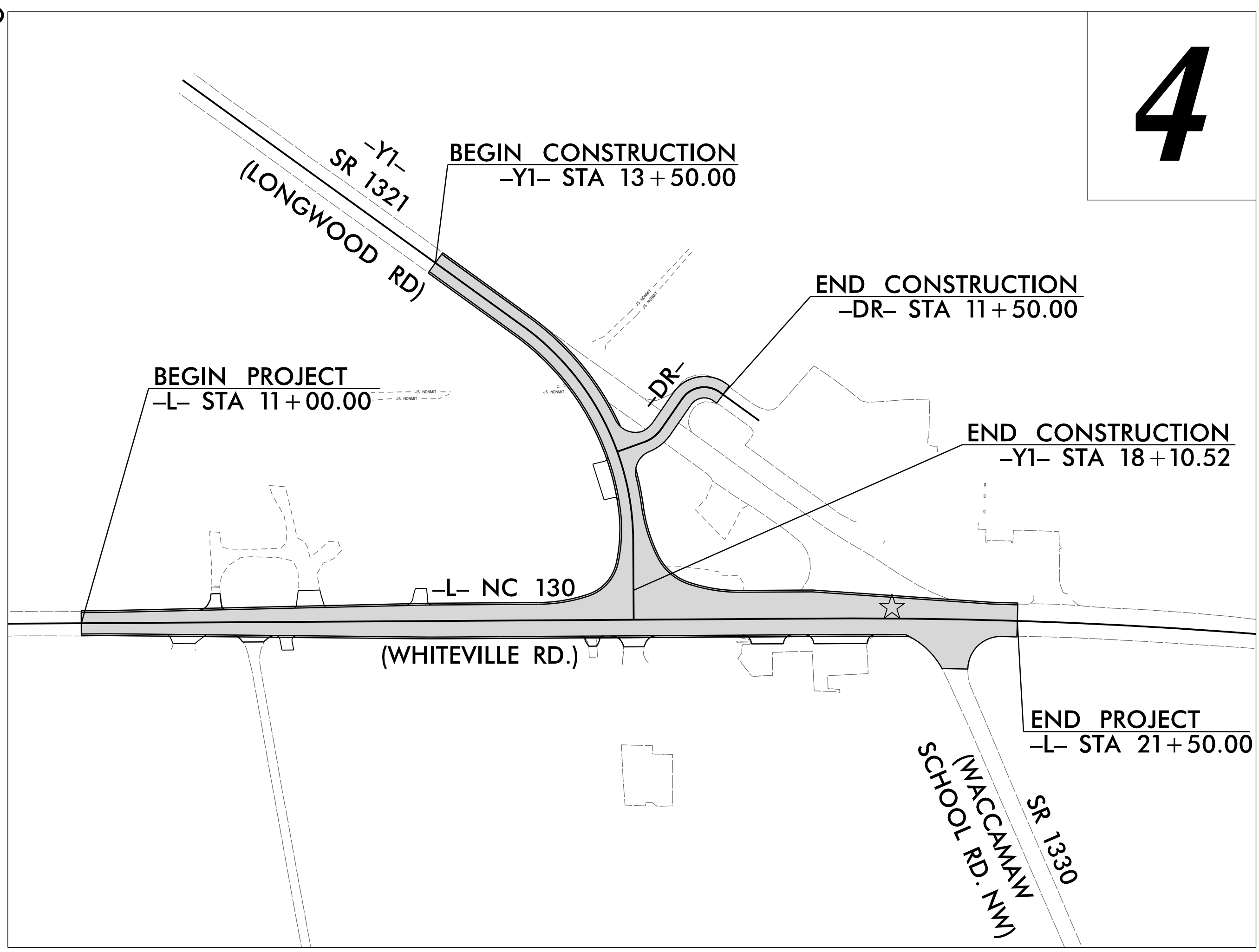

NAD 83/2011

☆ EXISTING SIGNAL TO BE REMOVED

DOCUMENT NOT CONSIDERED FINAL UNLESS ALL SIGNATURES COMPLETED

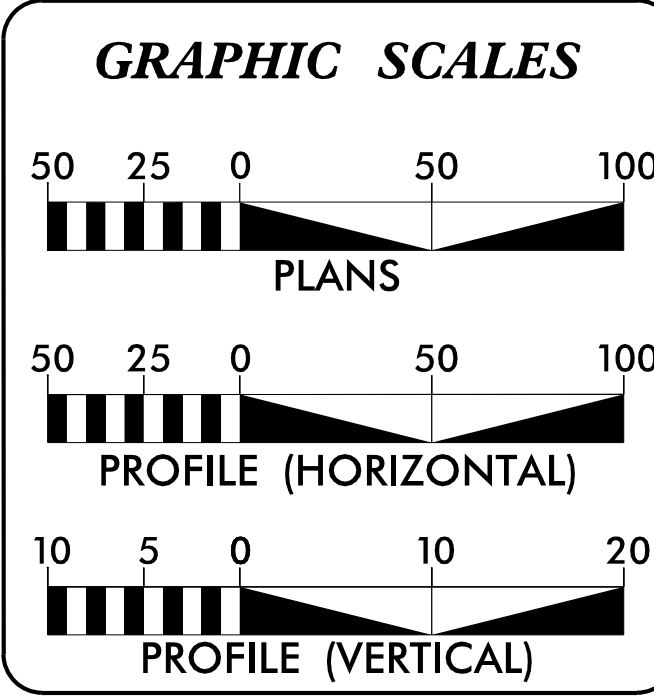

DESIGN DATA

ADT -L- 2022 = 6730
ADT -L- 2042 = 8060

V = 60 MPH

FUNC CLASS = MINOR ARTERIAL

PROJECT LENGTH

LENGTH ROADWAY TIP PROJECT W-5703Q (-L-) = 0.199 MILES
LENGTH ROADWAY TIP PROJECT W-5703Q (-Y1-) = 0.087 MILES
TOTAL LENGTH TIP PROJECT W-5703Q = 0.286 MILES

ERIC MURRAY
NCDOT CONTACT, DIVISION 3

Prepared in the Office of:

SUMMIT
DESIGN AND ENGINEERING SERVICES
FIRM NO. P-40339

320 Executive Ct.
Hillsborough, NC 27278-8551
Voice: (919) 732-3883
Fax: (919) 732-6776
www.summitde.net

2018 STANDARD SPECIFICATIONS

RIGHT OF WAY DATE: DECEMBER 28, 2018

LETTING DATE: APRIL 21, 2022

BRANDON W. JOHNSON, PE
PROJECT ENGINEER

FAITH E. JAHNKE, PE
PROJECT DESIGN ENGINEER

HYDRAULICS ENGINEER

3/16/2022

DocuSigned by:
Jason M. Patloski
SEAL 046226
SIGNATURE: JASON M. PATLOSKI, P.E.

ROADWAY DESIGN ENGINEER

3/15/2022

DocuSigned by:
Brandon W. Johnson
SEAL 034371
SIGNATURE: BRANDON W. JOHNSON, P.E.

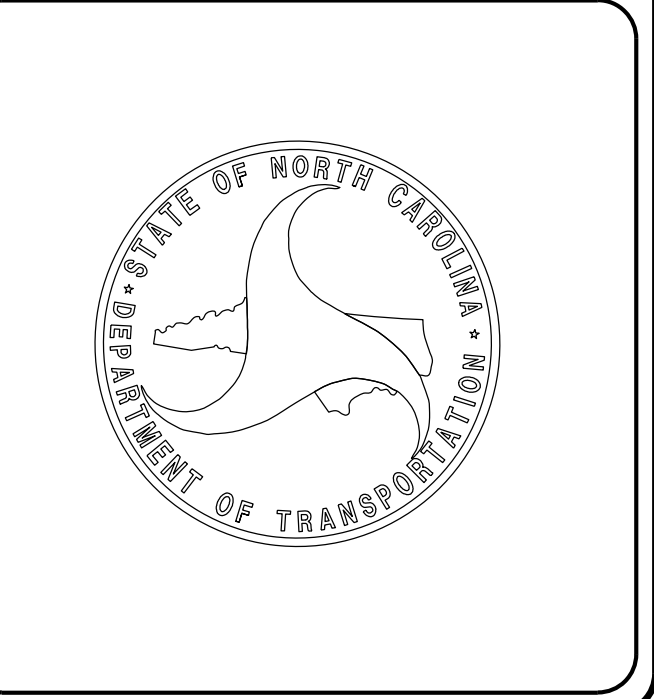

8/17/99

PROJECT REFERENCE NO.	SHEET NO.
W-57030	1A

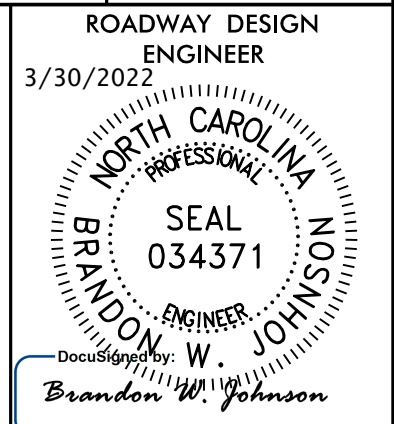

**DOCUMENT NOT CONSIDERED FINAL
UNLESS ALL SIGNATURES COMPLETED**

	INDEX OF SHEETS		EFF. 01-16-2018 REV.
SHEET NUMBER	SHEET	2018 ROADWAY ENGLISH STANDARD DRAWINGS	
1	TITLE SHEET	The following Roadway Standards as appear in "Roadway Standard Drawings" Highway Design Branch - N. C. Department of Transportation - Raleigh, N. C., Dated January, 2018 are applicable to this project and by reference hereby are considered a part of these plans:	
1A	INDEX OF SHEETS, GENERAL NOTES, AND STANDARD DRAWINGS		
1B	CONVENTIONAL SYMBOLS	STD. NO.	TITLE
2A-1 THRU 2A-2	PAVEMENT SCHEDULE AND TYPICAL SECTIONS	DIVISION 2 - EARTHWORK	
2C-1	SPECIAL DETAILS	225.02	Guide for Grading Subgrade - Secondary and Local
3B-1	ROADWAY SUMMARIES	225.04	Method of Obtaining Superelevation - Two Lane Pavement
3D-1	DRAINAGE SUMMARIES	225.06	Method of Grading Sight Distance at Intersections
3P-1	PARCEL INDEX SHEET	DIVISION 3 - PIPE CULVERTS	
4 THRU 5	PLAN AND PROFILE SHEET	300.01	Method of Pipe Installation
RW01 THRU RW04	SURVEY CONTROL SHEETS	310.02	Parallel Pipe End Section - Precast Concrete Section for 15" to 24" Pipe
TMP-1 THRU TMP-4	TRAFFIC MANAGEMENT PLANS	310.10	Driveway Pipe Construction
PMP-1 THRU PMP-2	PAVEMENT MARKING PLANS	DIVISION 5 - SUBGRADE, BASES AND SHOULDERS	
EC-1 THRU EC-5	EROSION CONTROL PLANS	560.01	Method of Shoulder Construction - High Side of Superelevated Curve - Method 1
UC-1 THRU UC-4	UTILITIES CONSTRUCTION PLANS	DIVISION 6 - ASPHALT BASES AND PAVEMENTS	
UO-1 THRU UO-2	UTILITIES BY OTHERS PLANS	654.01	Pavement Repairs
X-0	CROSS-SECTION INDEX	DIVISION 8 - INCIDENTALS	
X-1 THRU X-14	CROSS-SECTIONS	840.00	Concrete Base Pad for Drainage Structures
		840.14	Concrete Drop Inlet - 12" thru 30" Pipe
		840.15	Brick Drop Inlet - 12" thru 30" Pipe
		840.16	Drop Inlet Frame and Grates - for use with Std. Dwg 840.14 and 840.15
		840.18	Concrete Grated Drop Inlet Type 'B' - 12" thru 36" Pipe
		840.24	Frames and Narrow Slot Sag Grates
		840.25	Anchorage for Frames - Brick or Concrete or Precast
		840.27	Brick Grated Drop Inlet Type 'B' - 12" thru 36" Pipe
		840.72	Pipe Collar
		876.02	Guide for Rip Rap at Pipe Outlets

GENERAL NOTES: 2018 SPECIFICATIONS EFFECTIVE: 01-16-2018 REVISED:

GRADING AND SURFACING OR RESURFACING AND WIDENING:
THE GRADE LINES SHOWN DENOTE THE FINISHED ELEVATION OF THE PROPOSED SURFACING AT GRADE POINTS SHOWN ON THE TYPICAL SECTIONS. WHERE NO GRADE LINES ARE SHOWN, THE PROFILES SHOWN DENOTE THE TOP ELEVATION OF THE EXISTING PAVEMENT ALONG THE CENTER LINE OF SURVEY ON WHICH THE PROPOSED RESURFACING WILL BE PLACED. GRADE LINES MAY BE ADJUSTED BY THE ENGINEER IN ORDER TO SECURE A PROPER TIE-IN.

CLEARING:
CLEARING ON THIS PROJECT SHALL BE PERFORMED TO THE LIMITS ESTABLISHED BY MODIFIED METHOD III.

SUPERELEVATION:
ALL CURVES ON THIS PROJECT SHALL BE SUPERELEVATED IN ACCORDANCE WITH STD. NO. 225.04 USING THE RATE OF SUPERELEVATION AND RUNOFF SHOWN ON THE PLANS. SUPERELEVATION IS TO BE REVOLVED ABOUT THE GRADE POINTS SHOWN ON THE TYPICAL SECTIONS.

SHOULDER CONSTRUCTION:
ASPHALT, EARTH, AND CONCRETE SHOULDER CONSTRUCTION ON THE HIGH SIDE OF SUPERELEVATED CURVES SHALL BE IN ACCORDANCE WITH STD. NO. 560.01

SIDE ROADS:
THE CONTRACTOR WILL BE REQUIRED TO DO ALL NECESSARY WORK TO PROVIDE SUITABLE CONNECTIONS WITH ALL ROADS, STREETS, AND DRIVES ENTERING THIS PROJECT. THIS WORK WILL BE PAID FOR AT THE CONTRACT UNIT PRICE FOR THE PARTICULAR ITEMS INVOLVED.

UTILITIES:
UTILITY OWNERS ON THIS PROJECT ARE Brunswick Electric Membership Corporation, AT&T, Brunswick County Water & Sewer
ANY RELOCATION OF EXISTING UTILITIES WILL BE ACCOMPLISHED BY OTHERS, EXCEPT AS SHOWN ON THE PLANS.

RIGHT-OF-WAY MARKERS:
ALL RIGHT-OF-WAY MARKERS ON THIS PROJECT SHALL BE PLACED BY OTHERS.

30-MAR-2022 08:48
W-57030_Roadway.tbl.dgn
F:\pub\johnk

STATE OF NORTH CAROLINA, DIVISION OF HIGHWAYS

CONVENTIONAL PLAN SHEET SYMBOLS

12/2/2016

BOUNDARIES AND PROPERTY:

State Line	-----
County Line	-----
Township Line	-----
City Line	-----
Reservation Line	-----
Property Line	-----
Existing Iron Pin	○ EIP
Computed Property Corner	-----
Property Monument	□ ECM
Parcel/Sequence Number	①23
Existing Fence Line	-x-x-x-
Proposed Woven Wire Fence	○
Proposed Chain Link Fence	□
Proposed Barbed Wire Fence	◇
Existing Wetland Boundary	----- WLB
Proposed Wetland Boundary	----- WLB
Existing Endangered Animal Boundary	----- EAB
Existing Endangered Plant Boundary	----- EPB
Existing Historic Property Boundary	----- HPB
Known Contamination Area: Soil	☠-s-☠
Potential Contamination Area: Soil	☠-s-☠
Known Contamination Area: Water	☠-w-☠
Potential Contamination Area: Water	☠-w-☠
Contaminated Site: Known or Potential	☠?

BUILDINGS AND OTHER CULTURE:

Gas Pump Vent or U/G Tank Cap	○
Sign	○ S
Well	○ W
Small Mine	✕
Foundation	□
Area Outline	□
Cemetery	□
Building	□
School	□
Church	□
Dam	□

HYDROLOGY:

Stream or Body of Water	-----
Hydro, Pool or Reservoir	□
Jurisdictional Stream	----- JS
Buffer Zone 1	----- BZ 1
Buffer Zone 2	----- BZ 2
Flow Arrow	←
Disappearing Stream	-----
Spring	○
Wetland	-----
Proposed Lateral, Tail, Head Ditch	-----
False Sump	▽

RAILROADS:

Standard Gauge	-----
RR Signal Milepost	○ MILEPOST 35
Switch	□ SWITCH
RR Abandoned	-----
RR Dismantled	-----

RIGHT OF WAY & PROJECT CONTROL:

Secondary Horiz and Vert Control Point	◆
Primary Horiz Control Point	○
Primary Horiz and Vert Control Point	◆
Exist Permanent Easement Pin and Cap	◇
New Permanent Easement Pin and Cap	◆
Vertical Benchmark	▲
Existing Right of Way Marker	△
Existing Right of Way Line	-----
New Right of Way Line	----- R/W
New Right of Way Line with Pin and Cap	----- R/W ▲
New Right of Way Line with Concrete or Granite R/W Marker	----- R/W ▲
New Control of Access Line with Concrete C/A Marker	----- C/A
Existing Control of Access	----- C/A
New Control of Access	----- C/A
Existing Easement Line	----- E
New Temporary Construction Easement	----- E
New Temporary Drainage Easement	----- TDE
New Permanent Drainage Easement	----- PDE
New Permanent Drainage / Utility Easement	----- DUE
New Permanent Utility Easement	----- PUE
New Temporary Utility Easement	----- TUE
New Aerial Utility Easement	----- AUE

ROADS AND RELATED FEATURES:

Existing Edge of Pavement	-----
Existing Curb	-----
Proposed Slope Stakes Cut	----- C
Proposed Slope Stakes Fill	----- F
Proposed Curb Ramp	----- CR
Existing Metal Guardrail	-----
Proposed Guardrail	-----
Existing Cable Guiderail	-----
Proposed Cable Guiderail	-----
Equality Symbol	⊕
Pavement Removal	-----

VEGETATION:

Single Tree	○
Single Shrub	○

Note: Not to Scale *S.U.E. = *Subsurface Utility Engineering*

Hedge	-----
Woods Line	-----
Orchard	-----
Vineyard	----- Vineyard

EXISTING STRUCTURES:

MAJOR:	
Bridge, Tunnel or Box Culvert	----- CONC
Bridge Wing Wall, Head Wall and End Wall	----- CONC WW
MINOR:	
Head and End Wall	----- CONC HW
Pipe Culvert	-----
Footbridge	-----
Drainage Box: Catch Basin, DI or JB	□ CB
Paved Ditch Gutter	-----
Storm Sewer Manhole	○ S
Storm Sewer	----- S

UTILITIES:

POWER:	
Existing Power Pole	●
Proposed Power Pole	○
Existing Joint Use Pole	●
Proposed Joint Use Pole	○
Power Manhole	⊕
Power Line Tower	⊗
Power Transformer	⊗
U/G Power Cable Hand Hole	○
H-Frame Pole	●
U/G Power Line LOS B (S.U.E.*)	----- P
U/G Power Line LOS C (S.U.E.*)	----- P
U/G Power Line LOS D (S.U.E.*)	----- P

TELEPHONE:

Existing Telephone Pole	●
Proposed Telephone Pole	○
Telephone Manhole	⊕
Telephone Pedestal	⊕
Telephone Cell Tower	⊕
U/G Telephone Cable Hand Hole	○
U/G Telephone Cable LOS B (S.U.E.*)	----- T
U/G Telephone Cable LOS C (S.U.E.*)	----- T
U/G Telephone Cable LOS D (S.U.E.*)	----- T
U/G Telephone Conduit LOS B (S.U.E.*)	----- TC
U/G Telephone Conduit LOS C (S.U.E.*)	----- TC
U/G Telephone Conduit LOS D (S.U.E.*)	----- TC
U/G Fiber Optics Cable LOS B (S.U.E.*)	----- T FO
U/G Fiber Optics Cable LOS C (S.U.E.*)	----- T FO
U/G Fiber Optics Cable LOS D (S.U.E.*)	----- T FO

WATER:

Water Manhole	⊕
Water Meter	○
Water Valve	⊗
Water Hydrant	⊕
U/G Water Line LOS B (S.U.E.*)	----- W
U/G Water Line LOS C (S.U.E.*)	----- W
U/G Water Line LOS D (S.U.E.*)	----- W
Above Ground Water Line	----- A/G Water

TV:

TV Pedestal	⊕
TV Tower	⊗
U/G TV Cable Hand Hole	○
U/G TV Cable LOS B (S.U.E.*)	----- TV
U/G TV Cable LOS C (S.U.E.*)	----- TV
U/G TV Cable LOS D (S.U.E.*)	----- TV
U/G Fiber Optic Cable LOS B (S.U.E.*)	----- TV FO
U/G Fiber Optic Cable LOS C (S.U.E.*)	----- TV FO
U/G Fiber Optic Cable LOS D (S.U.E.*)	----- TV FO

GAS:

Gas Valve	◇
Gas Meter	⊕
U/G Gas Line LOS B (S.U.E.*)	----- G
U/G Gas Line LOS C (S.U.E.*)	----- G
U/G Gas Line LOS D (S.U.E.*)	----- G
Above Ground Gas Line	----- A/G Gas

SANITARY SEWER:

Sanitary Sewer Manhole	⊕
Sanitary Sewer Cleanout	⊕
U/G Sanitary Sewer Line	----- SS
Above Ground Sanitary Sewer	----- A/G Sanitary Sewer
SS Forced Main Line LOS B (S.U.E.*)	----- FSS
SS Forced Main Line LOS C (S.U.E.*)	----- FSS
SS Forced Main Line LOS D (S.U.E.*)	----- FSS

MISCELLANEOUS:

Utility Pole	●
Utility Pole with Base	□
Utility Located Object	○
Utility Traffic Signal Box	⊕
Utility Unknown U/G Line LOS B (S.U.E.*)	----- 7UTL
U/G Tank; Water, Gas, Oil	□
Underground Storage Tank, Approx. Loc.	⊕
A/G Tank; Water, Gas, Oil	□
Geoenvironmental Boring	⊕
U/G Test Hole LOS A (S.U.E.*)	○
Abandoned According to Utility Records	AATUR
End of Information	E.O.I.

6/2/2022

PAVEMENT SCHEDULE (FINAL PAVEMENT DESIGN)	
C1	PROP. APPROX. 1.5" ASPHALT CONCRETE SURFACE COURSE, TYPE S9.5B, AT AN AVERAGE RATE OF 165 LBS. PER SQ. YD.
C2	PROP. APPROX. 3.0" ASPHALT CONCRETE SURFACE COURSE, TYPE S9.5B, AT AN AVERAGE RATE OF 165 LBS. PER SQ. YD. IN EACH OF TWO LAYERS.
C3	PROP. VAR. DEPTH ASPHALT CONCRETE SURFACE COURSE, TYPE S9.5B, AT AN AVERAGE RATE OF 110 LBS. PER SQ. YD. PER 1" DEPTH. TO BE PLACED IN LAYERS NOT TO EXCEED 2" IN DEPTH.
E1	PROP. APPROX. 4" ASPHALT CONCRETE BASE COURSE, TYPE B25.0C, AT AN AVERAGE RATE OF 456 LBS. PER SQ. YD.
E2	PROP. APPROX. 5.5" ASPHALT CONCRETE BASE COURSE, TYPE B25.0C, AT AN AVERAGE RATE OF 627 LBS. PER SQ. YD.
E3	PROP. VAR. DEPTH ASPHALT CONCRETE BASE COURSE, TYPE B25.0C, AT AN AVERAGE RATE OF 114 LBS. PER SQ. YD. PER 1" DEPTH. TO BE PLACED IN LAYERS NOT LESS THAN 3" IN DEPTH OR GREATER THAN 5 1/2" IN DEPTH.
T	EARTH MATERIAL.
U	EXISTING PAVEMENT.
V	MILLING BITUMINOUS PAVEMENT. VARIABLE 0" TO 1.5" DEPTH.
W	VARIABLE DEPTH ASPHALT PAVEMENT (SEE WEDGING DETAIL)

NOTE: PAVEMENT EDGE SLOPES ARE 1:1 UNLESS SHOWN OTHERWISE.

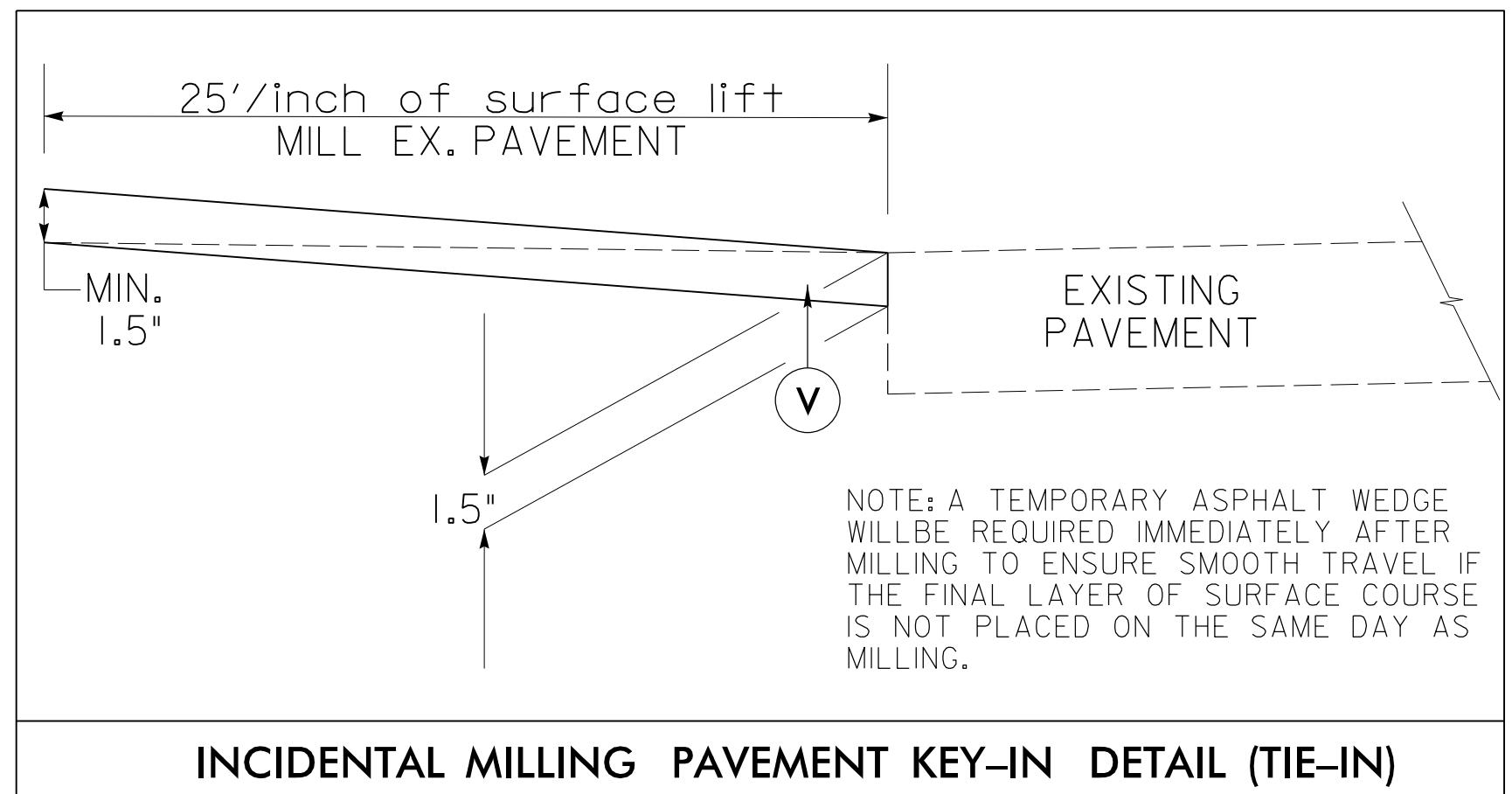

-L- STA 11+00.00 TO 11+37.50
 -L- STA 21+12.50 TO 21+50.00
 -Y1- STA 13+50.00 TO 13+87.50

STATION RANGES ARE APPROXIMATE ONLY.
 GRADE MAY BE ADJUSTED BY ENGINEER
 TO ENSURE A PROPER TIE-IN.

*SLOPES MAY BE STEEPER THAN 3:1 TO AVOID SLIVER FILL, NO SLOPE SHALL BE STEEPER THAN 2:1

PROJECT REFERENCE NO. W-5703Q	SHEET NO. 2A-1
ROADWAY DESIGN ENGINEER 3/9/2022	PAVEMENT DESIGN ENGINEER
<p>DOCUMENT NOT CONSIDERED FINAL UNLESS ALL SIGNATURES COMPLETED</p>	
Prepared in the Office of:	

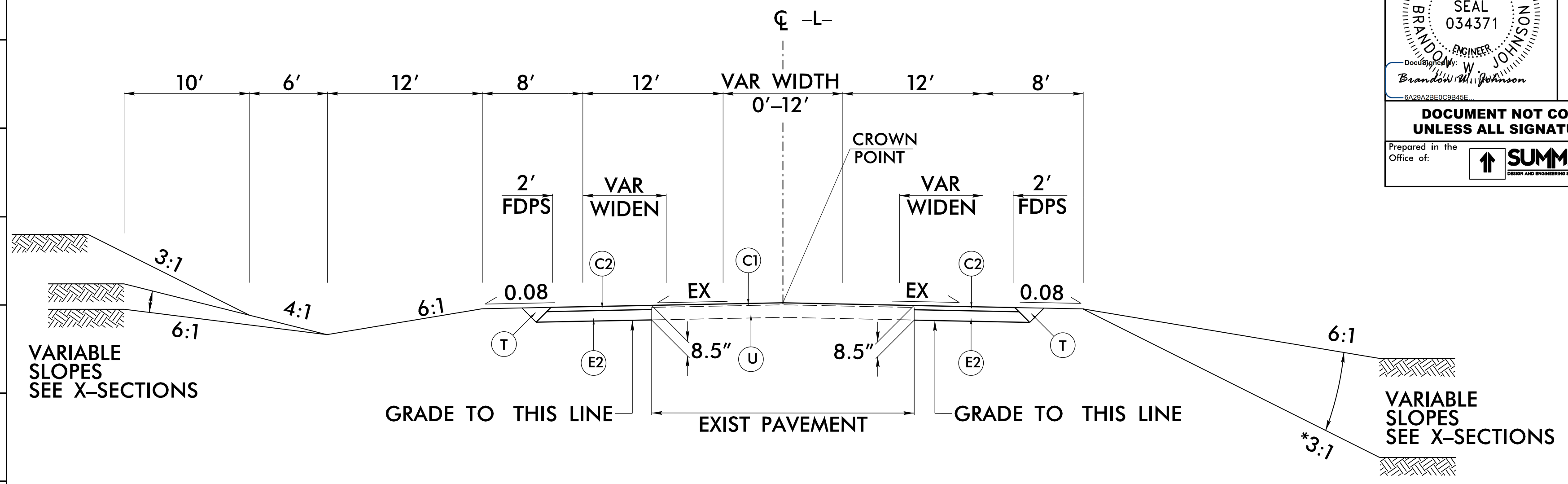

TYPICAL SECTION NO. 1

USE TYPICAL SECTION NO. 1
 -L- STA 11+00.00 TO 21+50.00

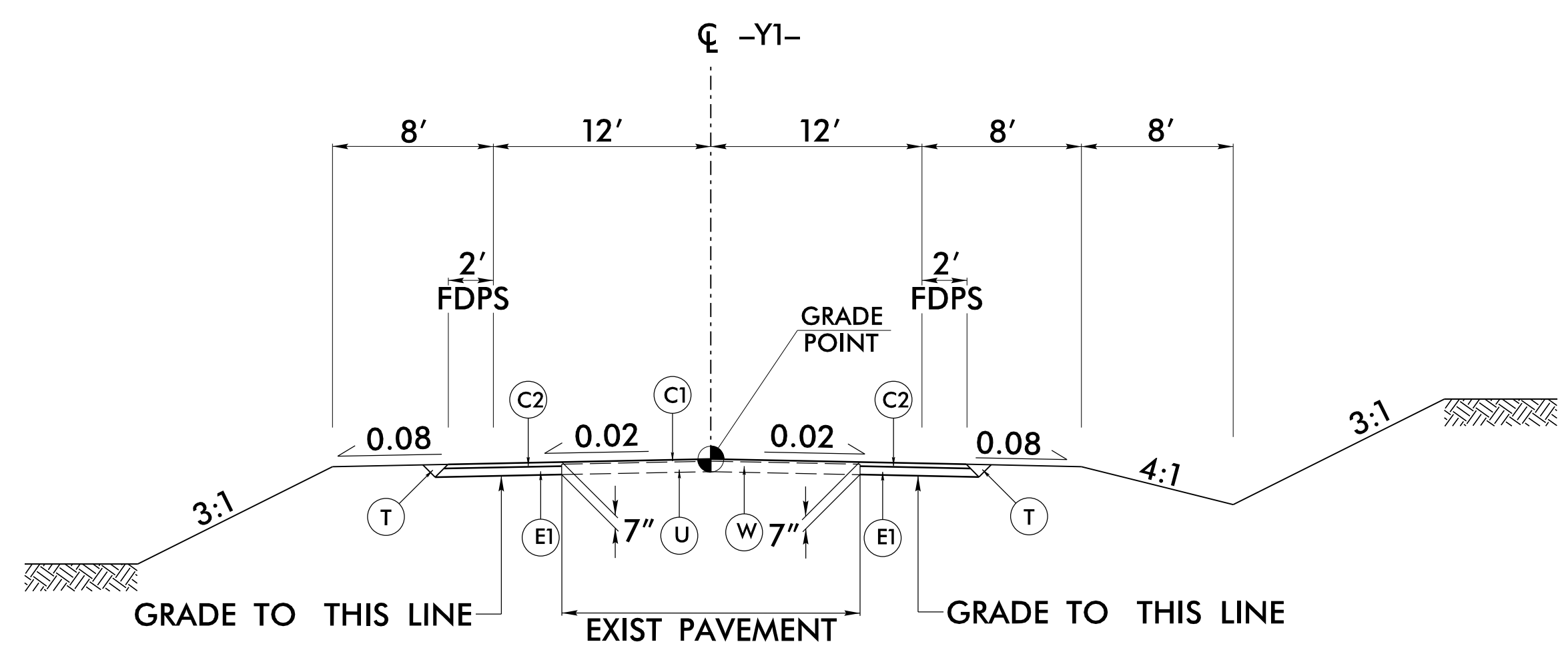

TYPICAL SECTION NO. 2

USE TYPICAL SECTION NO. 2
 -Y1- STA 13+50.00 TO 15+75.00

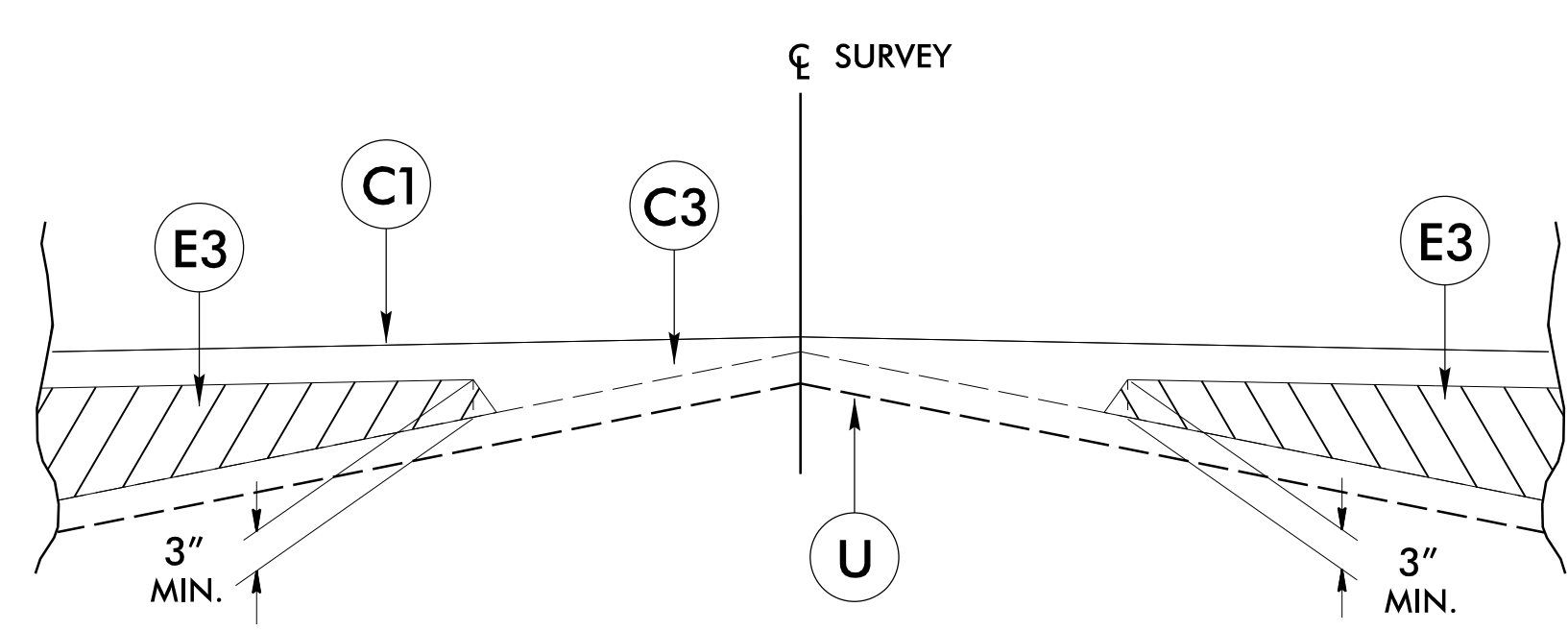



Detail Showing Method of Wedging

01/18/2022 17:26
 01/18/2022 17:26
 01/18/2022 17:26

6/2/2022

PAVEMENT SCHEDULE	
C2	3" S9.5B
E1	4" B25.0C
T	EARTH MATERIAL
U	EXIST PAVEMENT
W	WEDGING

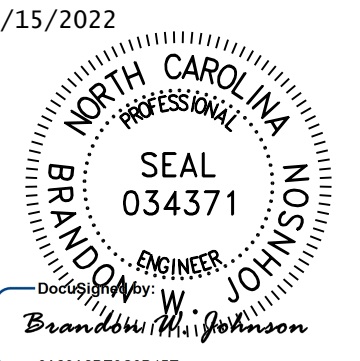
NOTE: PAVEMENT EDGE SLOPES ARE 1:1 UNLESS SHOWN OTHERWISE.

PROJECT REFERENCE NO. W-5703Q	SHEET NO. 2A-2
ROADWAY DESIGN ENGINEER 3/15/2022	PAVEMENT DESIGN ENGINEER
	
<p>DOCUMENT NOT CONSIDERED FINAL UNLESS ALL SIGNATURES COMPLETED</p>	
Prepared in the Office of:	

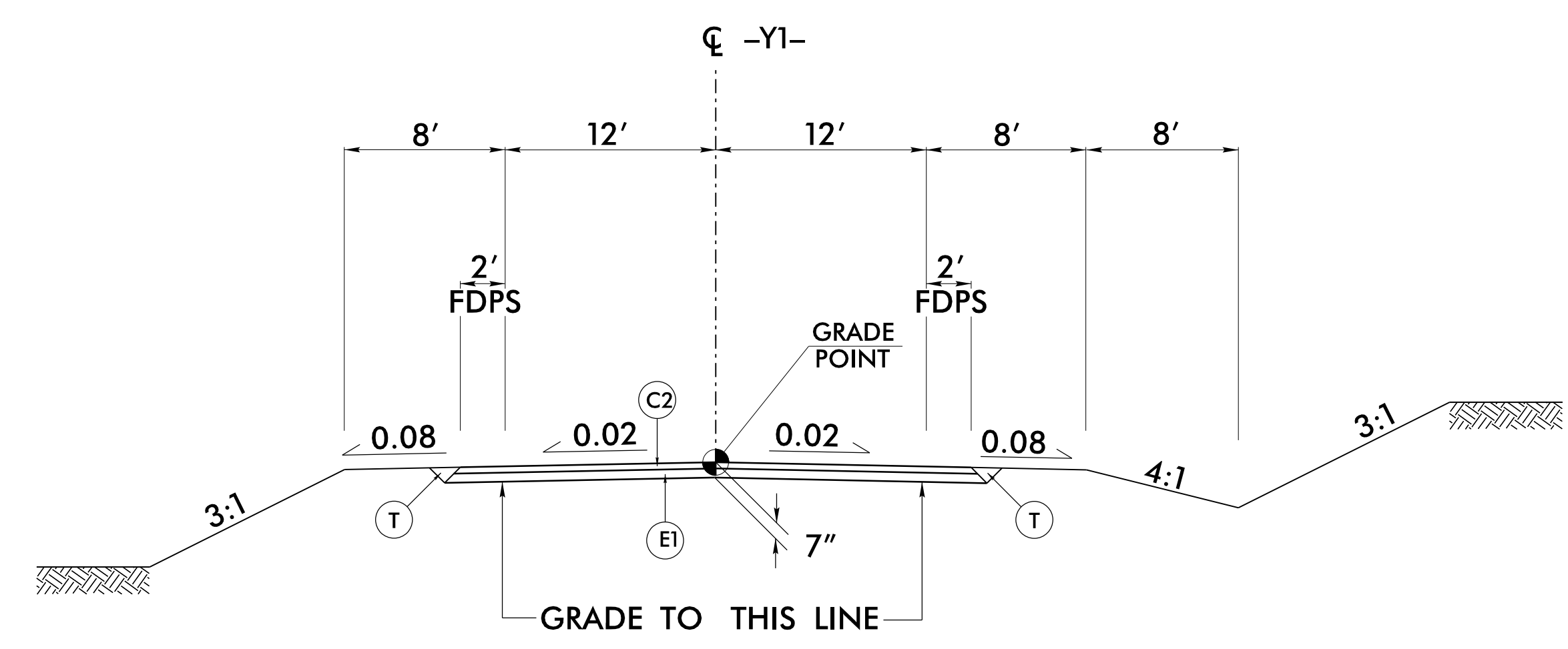

TYPICAL SECTION NO. 3

USE TYPICAL SECTION NO. 3
-Y1- STA 15+75.00 TO 18+10.52

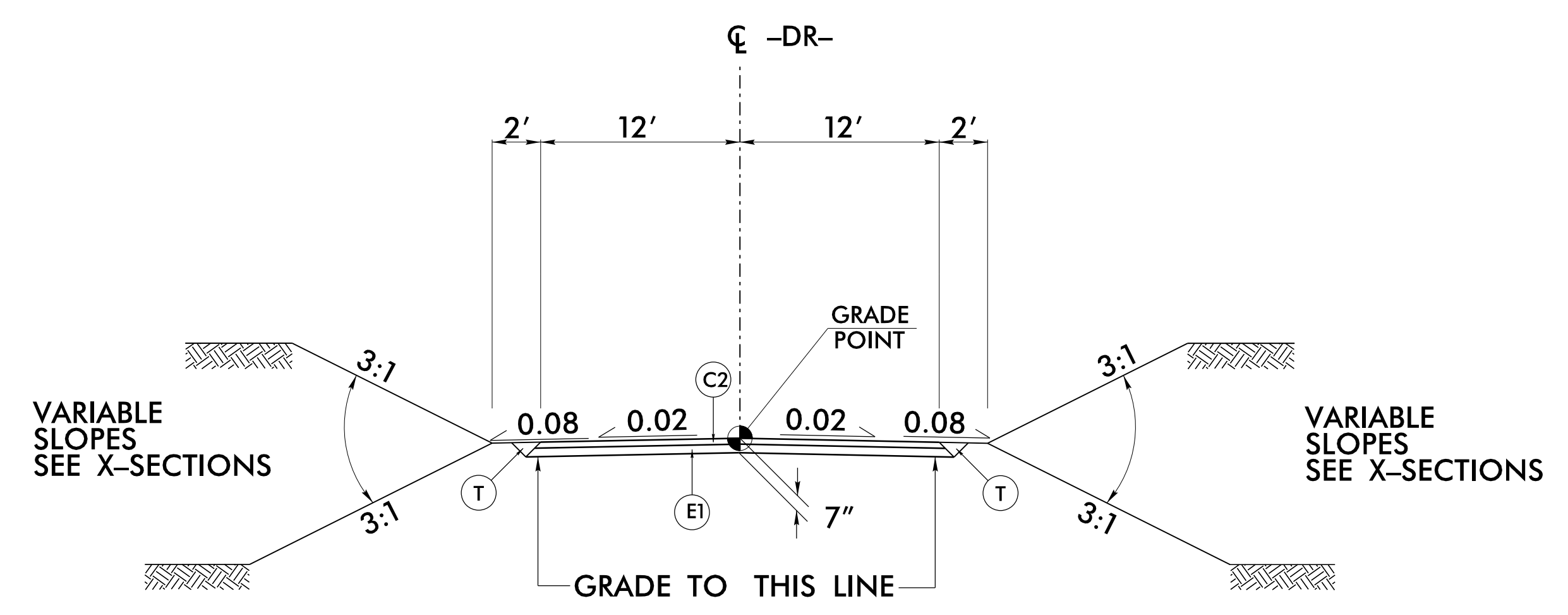

TYPICAL SECTION NO. 4

USE TYPICAL SECTION NO. 4
-DR- STA 10+10.00 TO 10+50.00

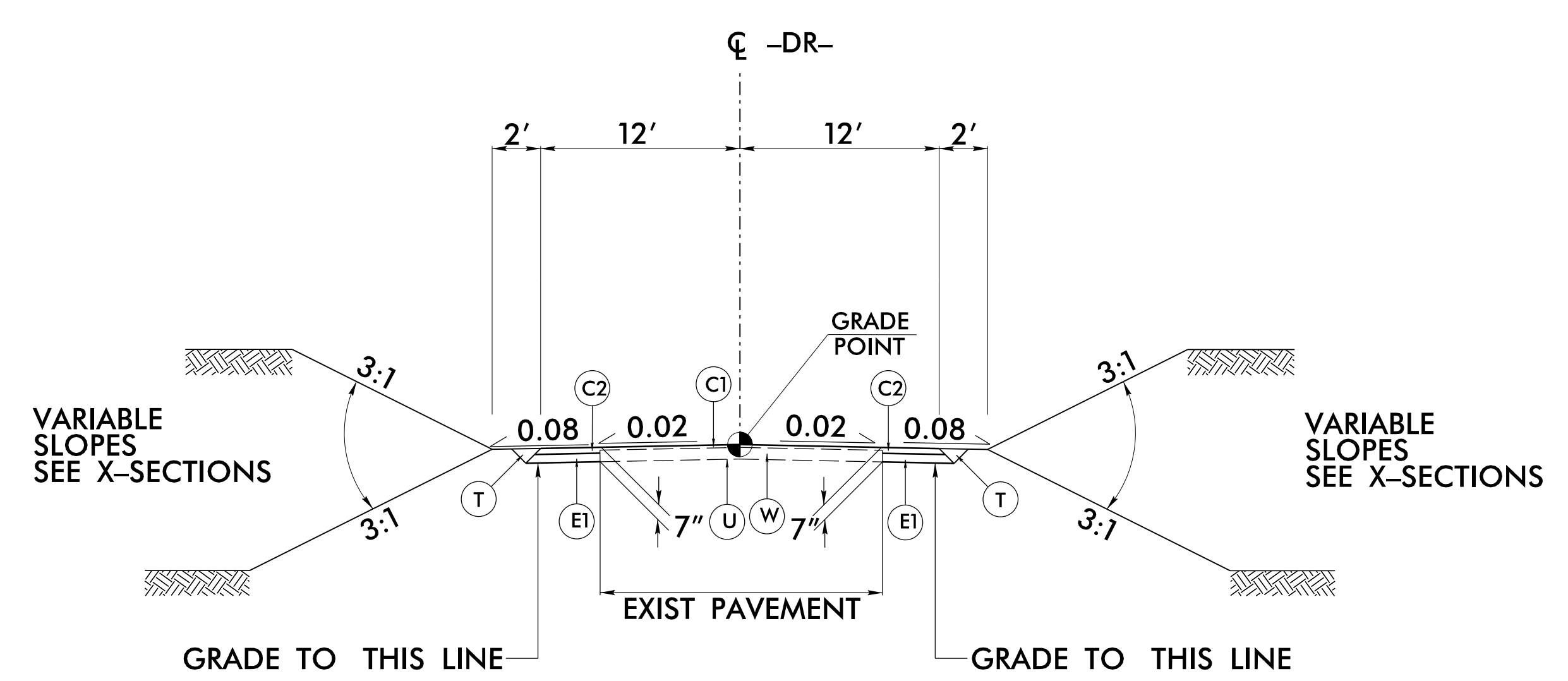

TYPICAL SECTION NO. 5

USE TYPICAL SECTION NO. 5
-DR- STA 10+50.00 TO 11+50.00

15-MAR-2022 16:54
W-5703Q-2A-2.dgn
F:\b\johns_b\p-2A-2.dgn

STATE OF NORTH CAROLINA
DEPT. OF TRANSPORTATION
DIVISION OF HIGHWAYS
RALEIGH, N.C.

ENGLISH DETAIL DRAWING FOR
METHOD OF CLEARING
MODIFIED METHOD - III

STATE OF NORTH CAROLINA
DEPT. OF TRANSPORTATION
DIVISION OF HIGHWAYS
RALEIGH, N.C.

ENGLISH DETAIL DRAWING FOR
METHOD OF CLEARING
MODIFIED METHOD - III

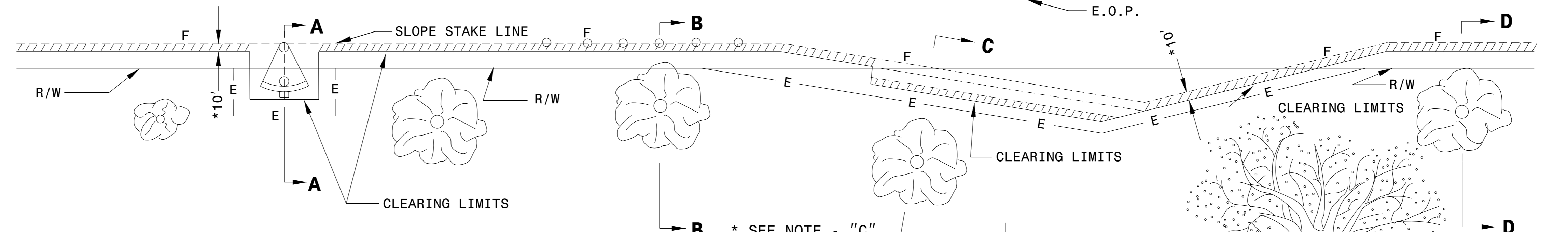
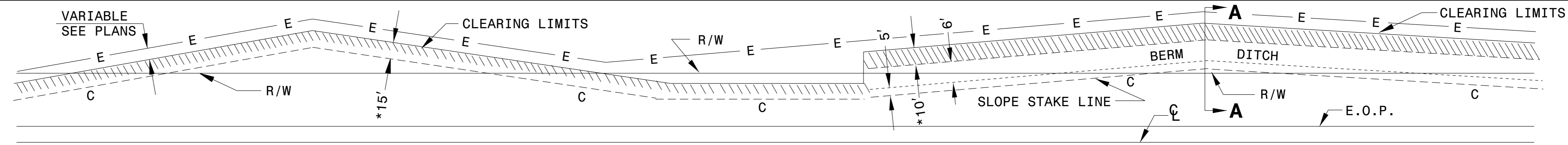

GENERAL NOTES:

- 1. REMOVE TREES OUTSIDE THE CLEARING LIMIT WHEN, IN THE OPINION OF THE ENGINEER, THE UTILITY OF A TREE WILL BE DESTROYED BY THE CONSTRUCTION OR THE CLEARING OPERATION.
- 2. CLEAR IN ACCORDANCE WITH THIS STANDARD EXCEPT WHERE ADDITIONAL CLEARING IS REQUIRED FOR SAFETY AS SHOWN ON THE PLANS.

METHOD III CLEARING LIMITS

- (A) CUTS -- CLEAR TO CONSTRUCTION LIMITS.
- (B) FILLS - CLEAR TO 5'/10' * BEYOND CONSTRUCTION LIMITS, UNLESS SPECIFIED OTHERWISE BY WETLAND PERMIT.
- (C) CUTS AND FILLS - WHEN THE CLEARING LIMITS (A AND B) EXCEED THE PROPOSED R/W OR PROPOSED CONSTRUCTION EASEMENTS, THEN CLEAR ONLY TO THE R/W OR CONSTRUCTION EASEMENT WHICHEVER IS GREATER.

- * FOR FILL HEIGHTS LESS THAN 10' CLEAR TO 5' BEYOND CONSTRUCTION LIMITS.
- * FOR FILL HEIGHTS 10' OR GREATER CLEAR TO 10' BEYOND CONSTRUCTION LIMITS.
- ** PLACE SILT FENCE AT 5' BEYOND TOE OF SLOPE IN FILL SECTIONS WITH LESS THAN 10'. PLACE SILT FENCE AT 10' BEYOND TOE OF SLOPE IN FILL SECTIONS WITH 10' OR GREATER.

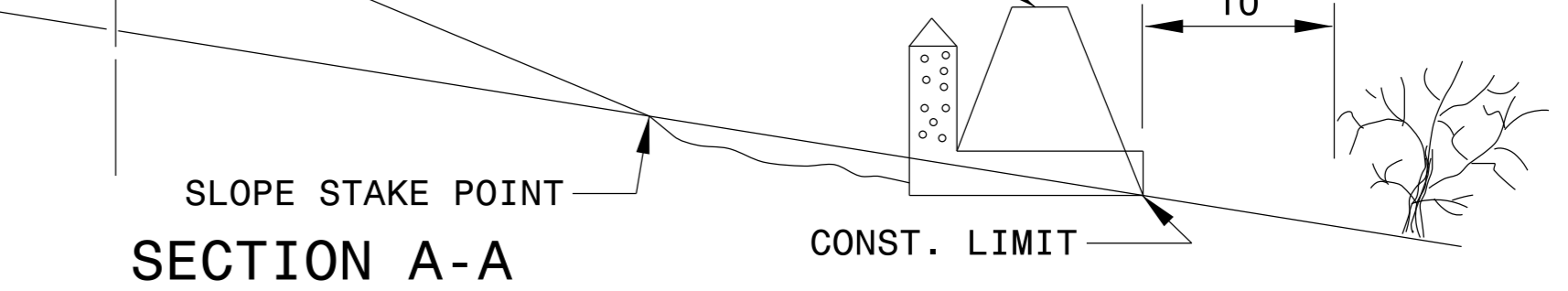
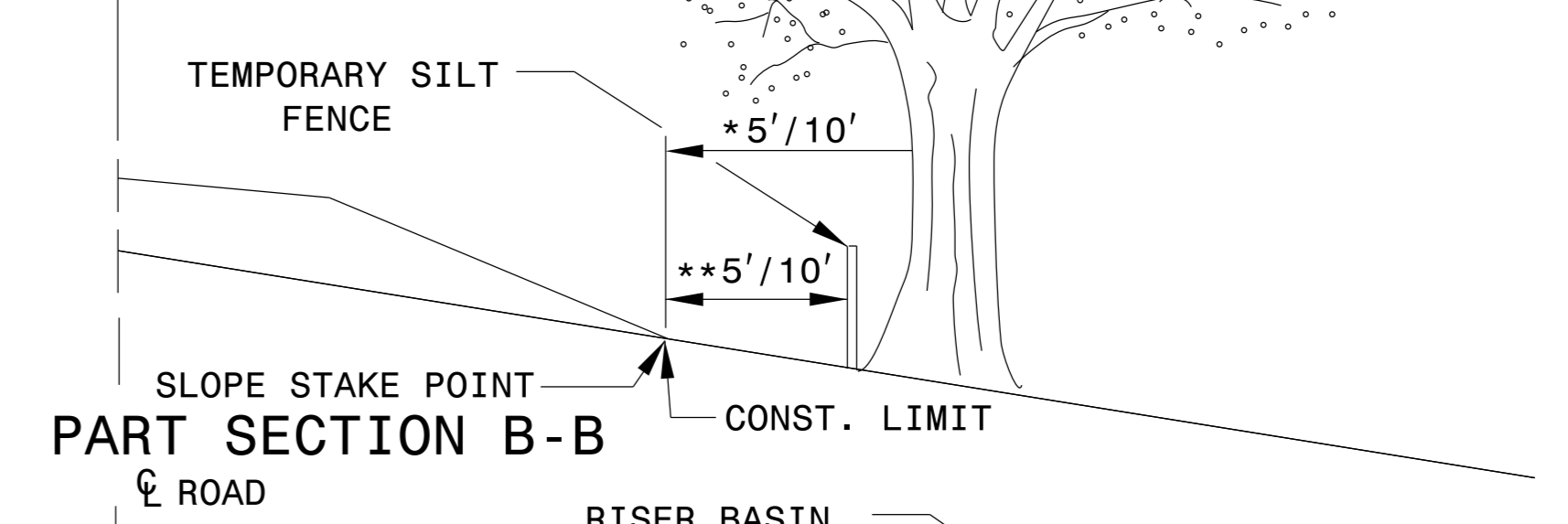
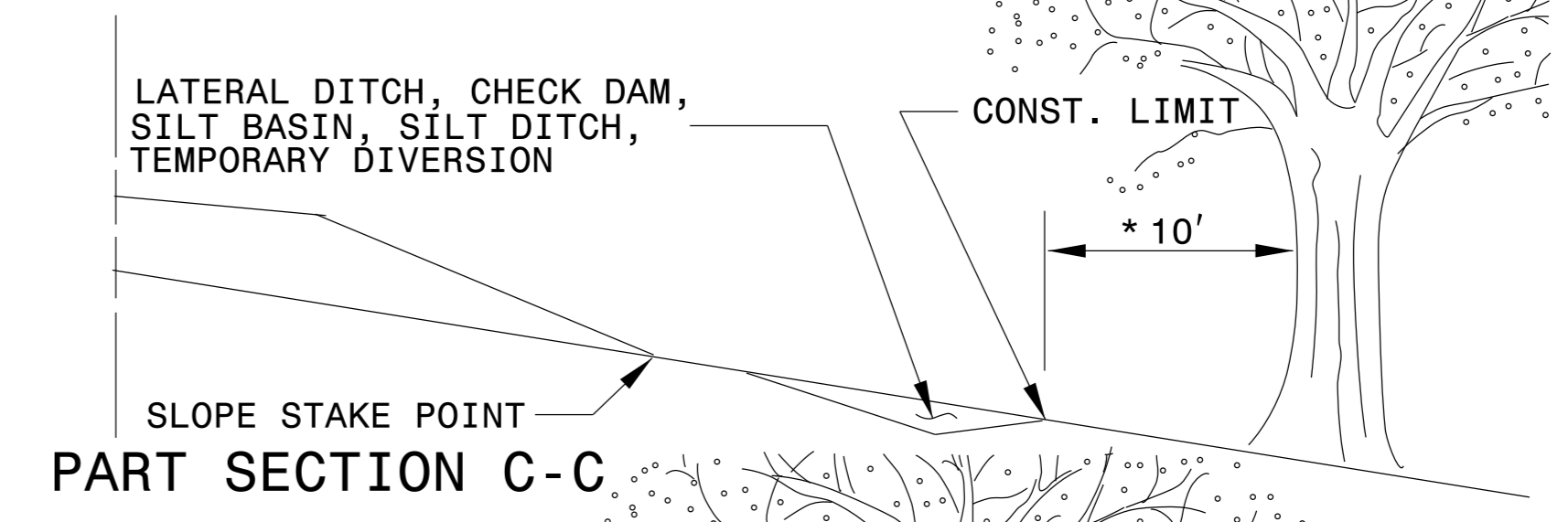
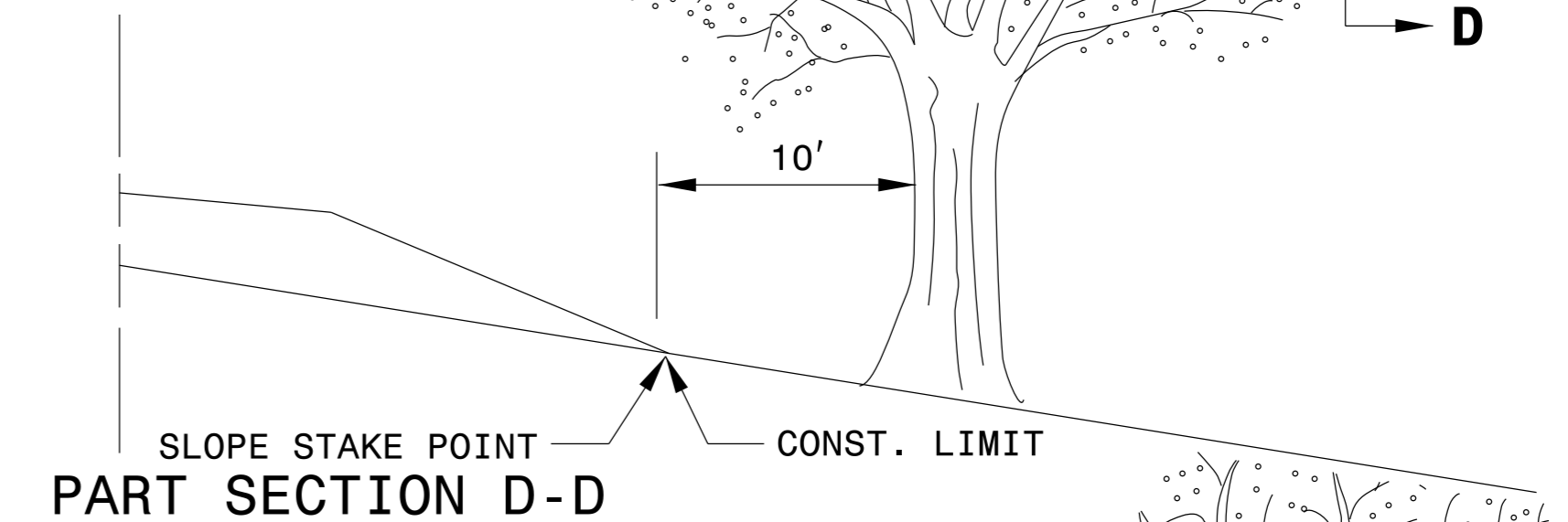
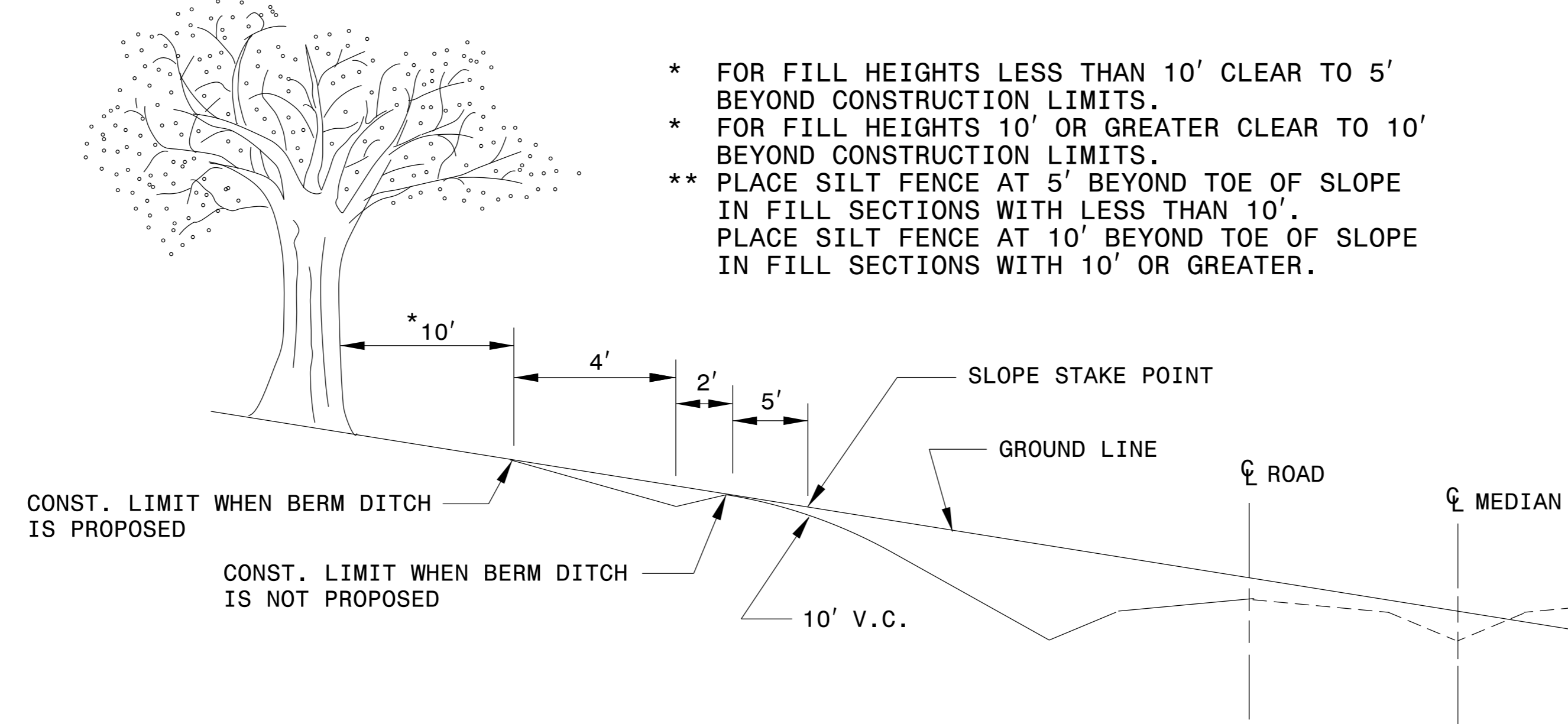

SHEET 1 OF 1
200D03

SHEET 1 OF 1
200D03

3/10/2022



DocuSigned by:
Ken Davenport
F8196038A7A442

DOCUMENT NOT CONSIDERED FINAL
UNLESS ALL SIGNATURES COMPLETED

CONTRACT STANDARDS
AND DEVELOPMENT UNIT
Office 919-707-6950 FAX 919-250-4119

SEE TITLE BLOCK

ORIGINAL BY: T.S.S. DATE: FEB. 2000
MODIFIED BY: K.A.K. DATE: AUG. 2016
CHECKED BY: DATE:
FILE SPEC.: kkempf/english/0200d301.dgn

5/14/99
C:\P\200D03\DRAWING\200D03.DWG
C:\P\200D03\DRAWING\200D03.DWG

STATE OF NORTH CAROLINA
DIVISION OF HIGHWAYS

SUMMARY OF PAVEMENT REMOVAL

LOCATION	AREA (SQFT)	AREA (SQYD)
-Y1- STA. 14+90.00 TO 16+31.00	2,706.78	300.75
-Y1- STA. 16+48.00 TO 18+14.00	11,750.02	1,305.56
TOTAL	14,456.80	1,606.31
SAY		1,610

SUMMARY OF EARTHWORK IN CUBIC YARDS

LOCATION	UNCLASSIFIED EXCAVATION	UNDERCUT	EMBT + 25%	BORROW	WASTE
-L- STA. 11+00.00 TO 21+50.00	208		518	310	
-Y1- STA. 13+50.00 TO 18+10.52	893		945	415	
-DR- STA. 10+10.00 TO 11+50.00	0		85	85	
TOTAL	1,101		1,548	447	
LOSS DUE TO CLEARING & GRUBBING					
PROJECT TOTALS	1,101		1,548	447	
5% TO REPLACE TOP SOIL				22	
GRAND TOTALS	1,101		1,548	469	
SAY	1,150			500	

APPROXIMATE QUANTITIES ONLY. UNCLASSIFIED EXCAVATION, BORROW EXCAVATION, SHOULDER BORROW, FINE GRADING, CLEARING AND GRUBBING, BREAKING OF EXISTING PAVEMENT AND REMOVAL OF EXISTING PAVEMENT WILL BE PAID FOR AT THE LUMP SUM PRICE FOR "GRADING".

COMPUTED BY: HY DATE: 1/7/2022
CHECKED BY: JMP DATE: 3/8/2022

NORTH CAROLINA DEPARTMENT OF TRANSPORTATION
DIVISION OF HIGHWAYS

PROJECT NO. W-5703Q SHEET NO. 3D-1





Note: Invert Elevations indicated are for Bid Purposes only and shall not be used for project construction stakeout.
See "Standard Specifications For Roads and Structures, Section 300-5".

LIST OF PIPES, ENDWALLS, ETC. (FOR PIPES 48 INCHES & UNDER)

Main data table with columns: LINE & STATION, OFFSET, STRUCTURE NUMBER, INVERT ELEVATION, MINIMUM REQUIRED SLOPE, R. C. PIPE CLASS IV, ENDWALLS, DRAINAGE STRUCTURE, QUANTITIES FOR DRAINAGE STRUCTURES, FRAME, GRATES, AND HOOD, CONCRETE TRANSITIONAL SECTION, etc.

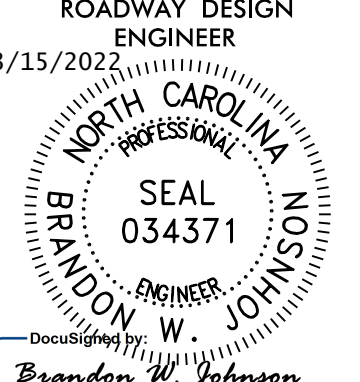
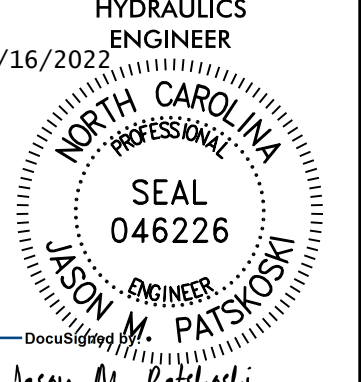
ABBREVIATIONS
C.A.A. CORRUGATED ALUMINIUM ALLOY
C.B. CATCH BASIN
C.S. CORRUGATED STEEL
D.I. DROP INLET
G.D.I. GRATED DROP INLET
H.D.P.E. HIGH DENSITY POLYETHYLENE
J.B. JUNCTION BOX
M.H. MANHOLE
N.S. NARROW SLOT
P.V.C. POLYVINYL CHLORIDE
R.C. REINFORCED CONCRETE
T.B.D.I. TRAFFIC BEARING DROP INLET
T.B.J.B. TRAFFIC BEARING JUNCTION BOX
W.S. WIDE SLOT

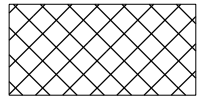
SHEET TOTALS and PROJECT TOTALS summary rows at the bottom of the table.

PROJECT REFERENCE NO. W-57030		SHEET NO. 4	
RW SHEET NO.			
ROADWAY DESIGN ENGINEER 3/15/2022		HYDRAULICS ENGINEER 3/16/2022	
			
<p>DOCUMENT NOT CONSIDERED FINAL UNLESS ALL SIGNATURES COMPLETED</p> <p>Prepared in the Office of: </p>			
<p>FOR -L- PROFILE, SEE SHEET 5 FOR -YI- PROFILE, SEE SHEET 5 FOR -DR- PROFILE, SEE SHEET 5</p>			
 PAVEMENT REMOVAL		 REMOVE EXISTING SIGNAL	

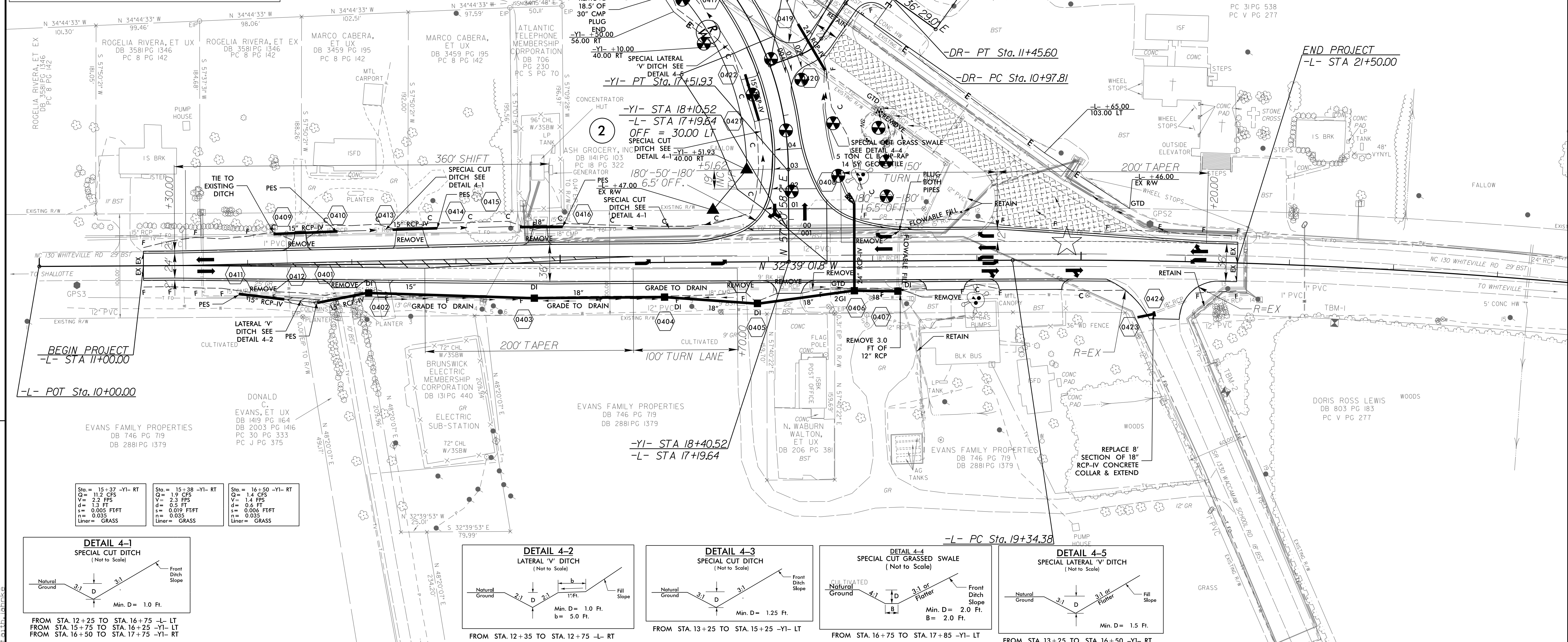
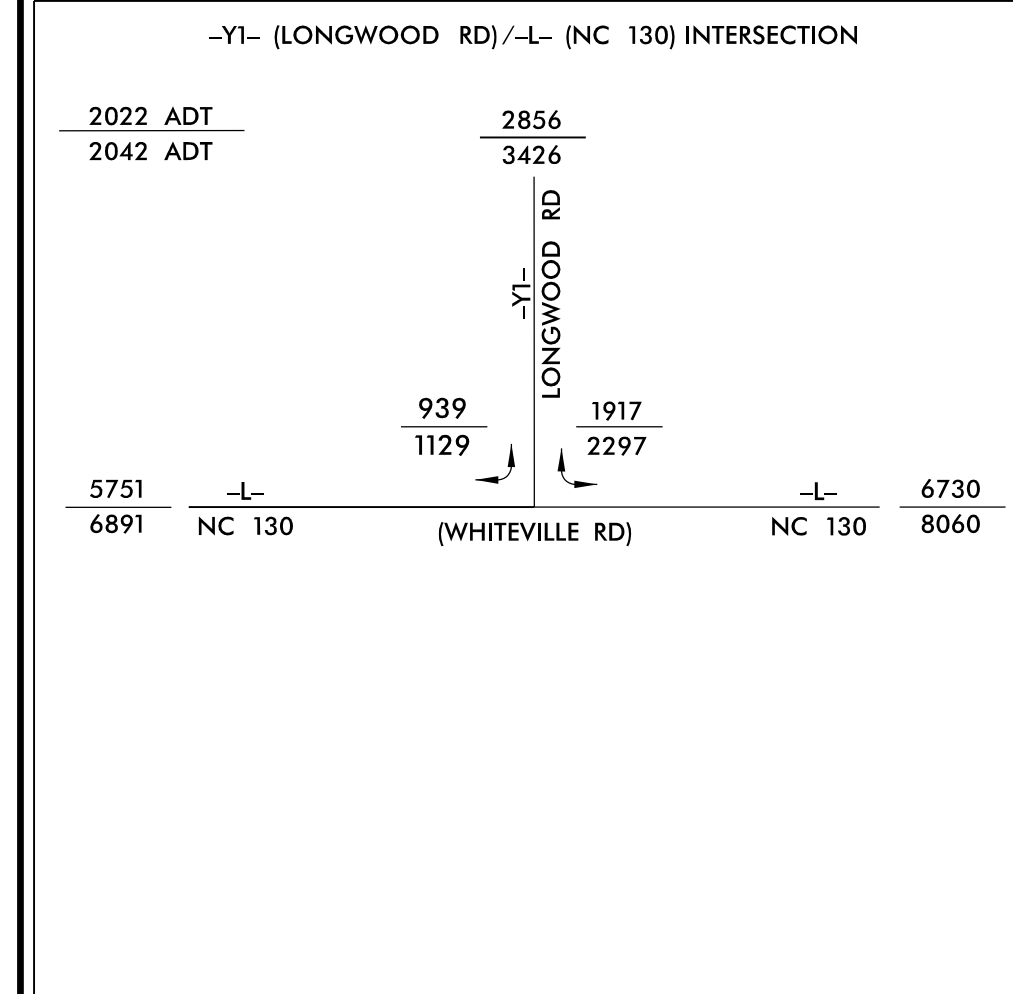

-L-
 PI Sta 22+78.41
 $\Delta = 6^{\circ}52'20.8''$ (RT)
 $D = 1^{\circ}00'00.0''$
 $L = 687.24'$
 $T = 344.03'$
 $R = 5,729.58'$
 $SE = EX$

-DR-
 PI Sta 11+28.48
 $\Delta = 9^{\circ}16'22.2''$ (RT)
 $D = 190^{\circ}59'09.4''$
 $L = 47.79'$
 $T = 30.67'$
 $R = 30.00'$

PI Sta 10+44.88
 $\Delta = 35^{\circ}32'49.6''$ (LT)
 $D = 143^{\circ}14'22.0''$
 $L = 24.82'$
 $T = 12.82'$
 $R = 40.00'$

Sta = 15+37 -YI- RT
 $Q = 11.2$ CFS
 $V = 2.2$ FPS
 $d = 1.3$ FT
 $s = 0.005$ FT/FT
 $n = 0.035$
 Liner = GRASS

Sta = 15+38 -YI- RT
 $Q = 1.9$ CFS
 $V = 2.3$ FPS
 $d = 0.5$ FT
 $s = 0.019$ FT/FT
 $n = 0.035$
 Liner = GRASS

Sta = 16+50 -YI- RT
 $Q = 1.4$ CFS
 $V = 1.4$ FPS
 $d = 0.4$ FT
 $s = 0.006$ FT/FT
 $n = 0.035$
 Liner = GRASS

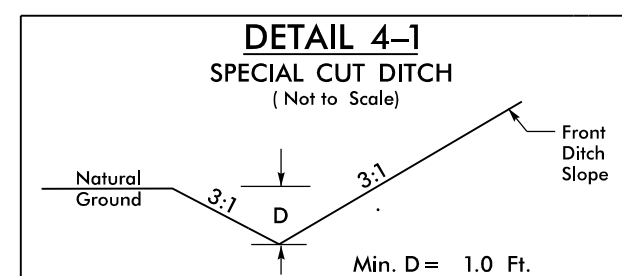

FROM STA. 12+25 TO STA. 16+75 -L- LT
 FROM STA. 15+75 TO STA. 16+25 -YI- LT
 FROM STA. 16+50 TO STA. 17+75 -YI- RT

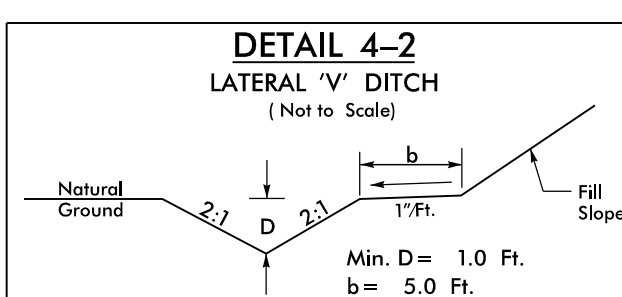

FROM STA. 12+35 TO STA. 12+75 -L- RT

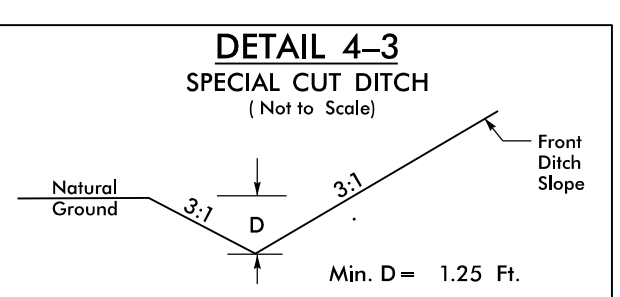

FROM STA. 13+25 TO STA. 15+25 -YI- LT

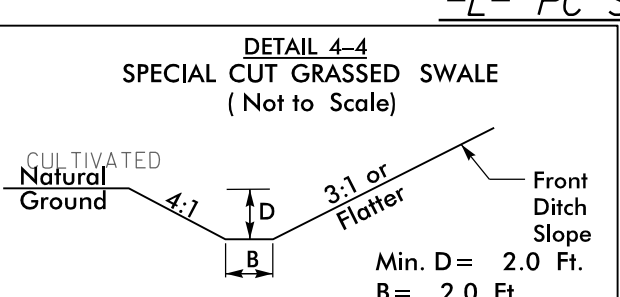

FROM STA. 16+75 TO STA. 17+85 -YI- LT

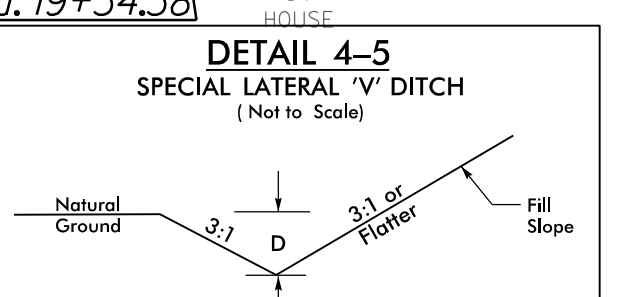

FROM STA. 13+25 TO STA. 16+50 -YI- RT

REVISIONS

8.17.799

15-MAR-2022 17:01
15-MAR-2022 17:01
15-MAR-2022 17:01
15-MAR-2022 17:01

5/28/22

PROJECT REFERENCE NO. W-5703Q	SHEET NO. 5
ROADWAY DESIGN ENGINEER 3/9/2022 BRANDON W. JOHNSON SEAL 034371	HYDRAULICS ENGINEER 3/9/2022 JASON M. PATSKOSKI SEAL 046226

DOCUMENT NOT CONSIDERED FINAL UNLESS ALL SIGNATURES COMPLETED

BM #2:
-L- STA 21+42.76, 124.23' RT
-BL- STA 17+41.00, 177.10' LT
EL 50.08'

BM #1:
-L- STA 22+46.06, 53.78' RT
-BL- STA 17+41.00, 201.05' LT
EL 51.03'

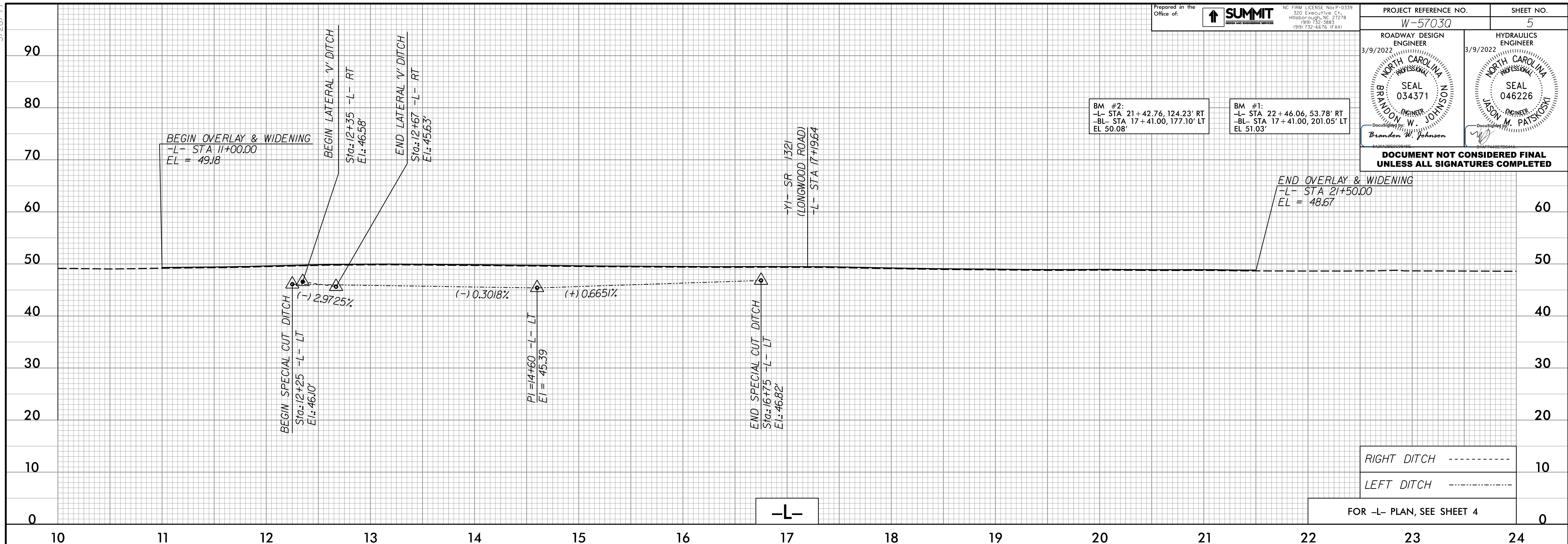

RIGHT DITCH -----

LEFT DITCH -----

FOR -L- PLAN, SEE SHEET 4

03-MAR-2022 11:38
W-5703Q_RCP-IV.dgn
faulstich

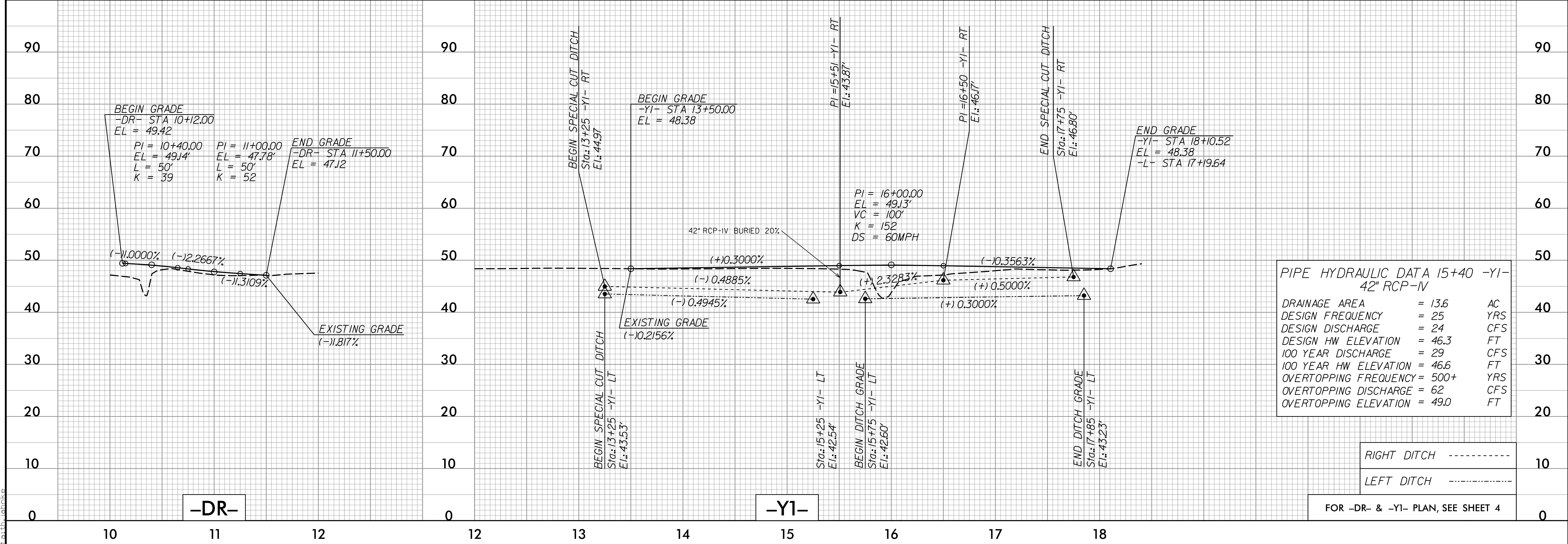

PIPE HYDRAULIC DATA 15+40 -YI-
42" RCP-IV

DRAINAGE AREA	= 13.6	AC
DESIGN FREQUENCY	= 25	YRS
DESIGN DISCHARGE	= 24	CFS
DESIGN HW ELEVATION	= 46.3	FT
100 YEAR DISCHARGE	= 29	CFS
100 YEAR HW ELEVATION	= 46.6	FT
OVERTOPPING FREQUENCY	= 500+	YRS
OVERTOPPING DISCHARGE	= 62	CFS
OVERTOPPING ELEVATION	= 49.0	FT

RIGHT DITCH -----

LEFT DITCH -----

FOR -DR- & -YI- PLAN, SEE SHEET 4

STATE	STATE PROJECT REFERENCE NO.	SHEET NO.	TOTAL SHEETS
N.C.	W-5703Q	RW01	05

STATE OF NORTH CAROLINA
DIVISION OF HIGHWAYS

SURVEY CONTROL, EXISTING CENTERLINES,
RIGHT OF WAY, EASEMENTS AND PROPERTY TIES

BRUNSWICK COUNTY

TIP PROJECT: W-5703Q

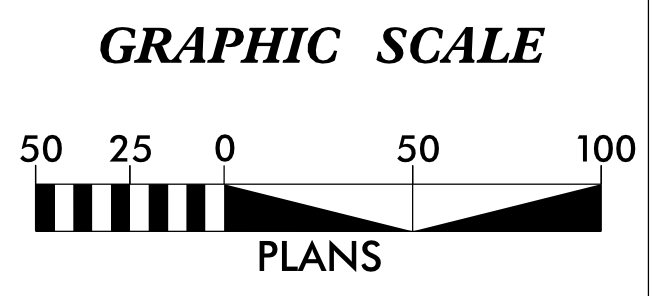
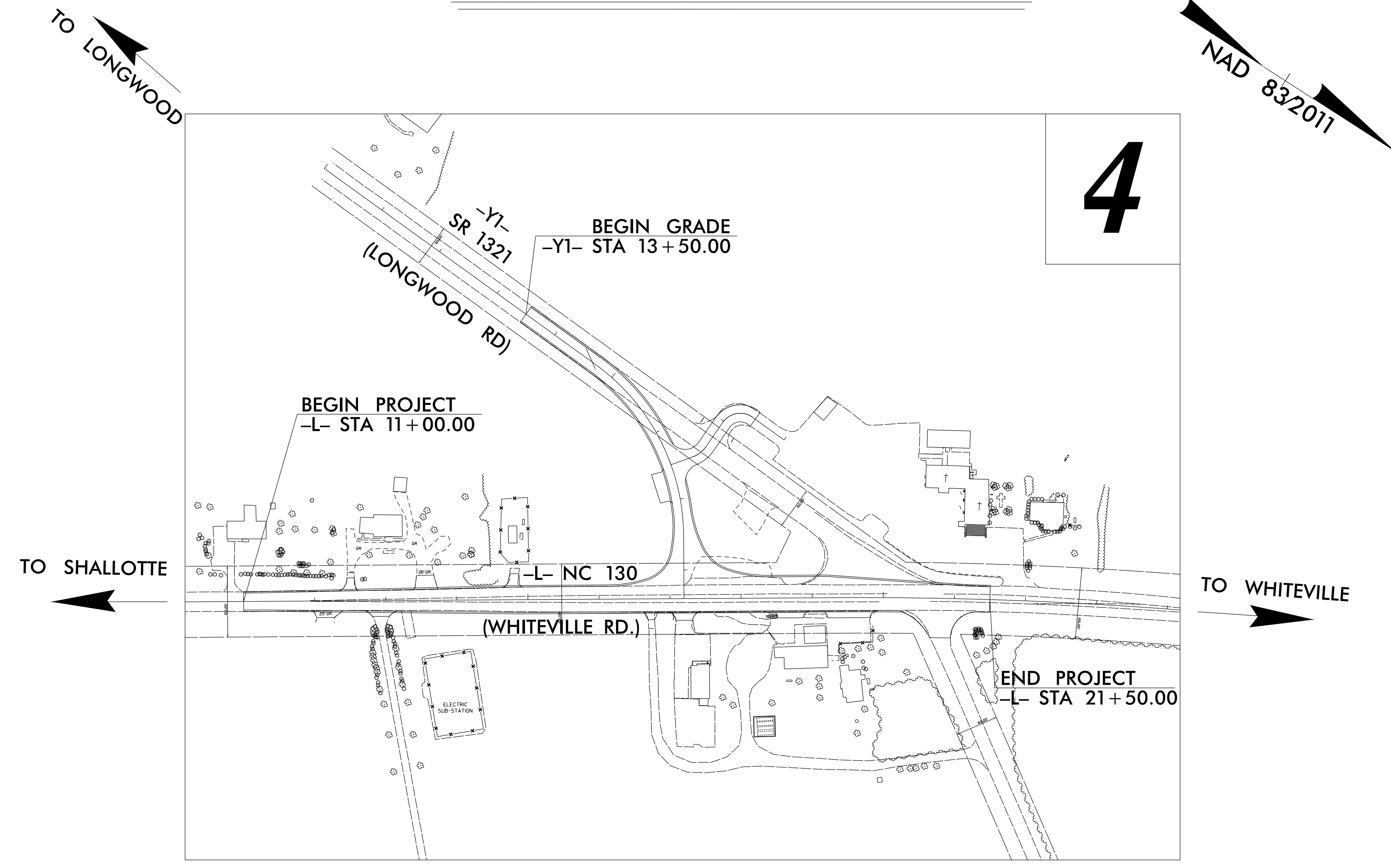

DATUM DESCRIPTION

THE LOCALIZED COORDINATE SYSTEM DEVELOPED FOR THIS PROJECT IS BASED ON THE STATE PLANE COORDINATES ESTABLISHED BY NCGS FOR MONUMENT "GPS2" WITH NAD 83/NA 2011 STATE PLANE GRID COORDINATES OF NORTHING: 112879.212(ft) EASTING: 2145045.416(ft) ELEVATION: 48.362(ft)

THE AVERAGE COMBINED GRID FACTOR USED ON THIS PROJECT (GROUND TO GRID) IS: 1.0000904400

THE N.C. LAMBERT GRID BEARING AND LOCALIZED HORIZONTAL GROUND DISTANCE FROM "GPS2" TO -L- STATION 10+00.00 IS S 34-28'27.8" E 1066.95(ft)

ALL LINEAR DIMENSIONS ARE LOCALIZED HORIZONTAL DISTANCES VERTICAL DATUM USED IS NAVD 88

Prepared in the Office of:

**DIVISION 3
LOCATION AND SURVEY'S UNIT
5310 BARBADOS BLVD, SUITE 102
CASTLE HAYNE, NORTH CAROLINA 28429**

2018 STANDARD SPECIFICATIONS

RIGHT OF WAY DATE: DECEMBER 28, 2018 **LETTING DATE:** APRIL 21, 2022

PROFESSIONAL LAND SURVEYOR

DocuSigned by:
Christopher J. Sawyer 03/11/2022

SIGNATURE: _____ Date: _____

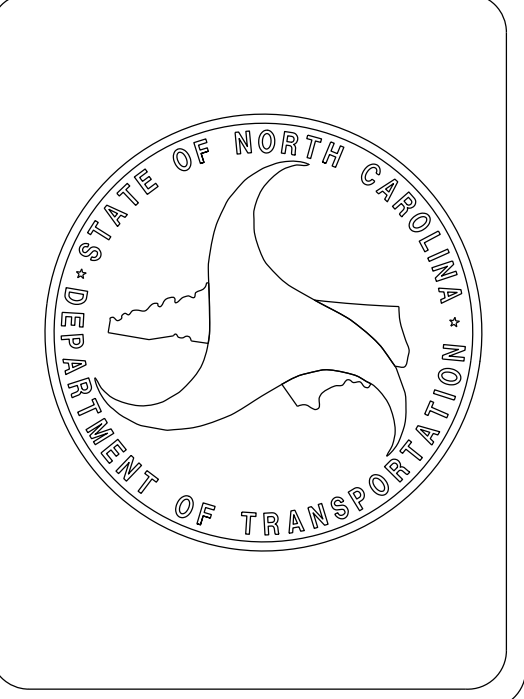

SURVEY CONTROL SHEET

W/ EXISTING CENTERLINE ALIGNMENTS PRIOR TO CONSTRUCTION

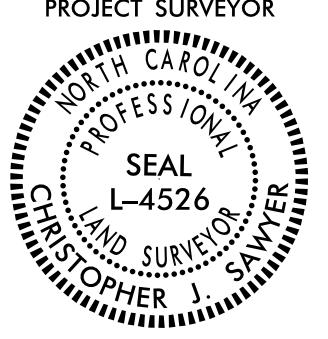
PROJECT REFERENCE NO. W-5703Q	SHEET NO. RW02C-1
Location and Surveys	
DIVISION 3 LOCATION AND SURVEYS UNIT 5310 BARBADOS BLVD, SUITE 102 CASTLE HAYNE, NORTH CAROLINA 28429	
PROJECT SURVEYOR 	
DOCUMENT NOT CONSIDERED FINAL UNLESS ALL SIGNATURES COMPLETED	



I, CHRISTOPHER J. SWAYER, PLS, certify that the Project Control was performed under my supervision from an actual GPS survey made under my supervision and the following information was used to perform the survey:

Class of survey: **AA**
 Type of GPS field procedure: RTN
 Dates of survey: June 22, 2016
 Datum/Epoch: NAD 1983/NA 2011
 Published/Fixed-control use: N/A FOR RTN
 Localized around: GPS2
 Northing: 112879.212
 Easting: 2145045.416
 Combined grid factor: 1.0000904400
 Geoid model:
 Units: US Survey feet

I also certify that the Baseline Control for this project was completed under my direct and responsible charge from an actual survey made under my supervision; that all horizontal closures had a minimum ratio of precision of 1:20,000 (Class AA) and Vertical accuracy to Class A. Field work was performed June 22, 2016, and all coordinates are based on NAD 83/2011 and all elevations are based on NAVD 88; that this survey was performed to meet the requirements of 21NCAC 56.1600 as applicable.

This 4th day of February, 2022.

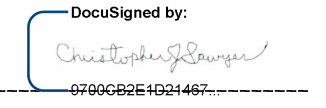
DocuSigned by:

 Professional Land Surveyor L-4526

BL POINT	DESC.	NORTH	EAST	ELEVATION
GPS1	GPS CAP AND REBAR	111638.1960	2145024.3100	48.24
GPS2	GPS CAP AND REBAR	112879.2120	2145045.4160	48.36
GPS3	GPS CAP AND REBAR	112039.8260	2145645.3050	48.40

EL POINT	N	E	BEARING	DIST	DELTA	D	L	T	R
POT	111999.644	2145649.348							
LINE			N 32°39'01.8" W	934.38					
PC	112786.370	2145145.238							
CURVE			N 29°12'51.4" W	686.83	06°52'20.8"(RT)	01°00'00.0"	687.24	344.03	5729.58
PT	113385.837	2144810.011							
LINE			N 25°46'41.0" W	55.95					
POT	113436.222	2144785.678							

EY POINT	N	E	BEARING	DIST
POT	111854.427	2145019.646		
LINE			N 03°34'13.4" E	1031.83
POT	112884.249	2145083.903		

EY1 POINT	N	E	BEARING	DIST
POT	112887.326	2145082.019		
LINE			N 34°17'47.3" E	585.17
POT	113370.756	2145411.749		

```

*****
TBM-1      ELEVATION = 51.03
N 113080   E 2145031
EL STATION 22+46.00 54 RIGHT
TBM-1     RR SPIKE IN BASE OF 15" PINE
*****

*****
TBM-2      ELEVATION = 50.08
N 113027   E 2145143
EY1 STATION 11+50.00 28 LEFT
TBM-2     RR SPIKE IN BASE OF 16" PINE
*****
    
```

NOTES:

1. PROJECT CONTROL WAS ESTABLISHED USING GNSS, THE GLOBAL NAVIGATION SATELLITE SYSTEM.
2. THE SURVEY CONTROL DATA FOR THIS PROJECT HAS BEEN COMPILED FROM VARIOUS SOURCES. IF FURTHER INFORMATION REGARDING PROJECT CONTROL IS NEEDED, PLEASE CONTACT THE LOCATION AND SURVEYS UNIT.

PROPOSED ALIGNMENT CONTROL SHEET

I, CHRISTOPHER J. SAWER, PLS, certify that the data compiled came from available surveys/mapping performed by others and provided to me by NCDOT and do not certify to the accuracy or quality of the individual data sources.

This 4th day of February, 2022.

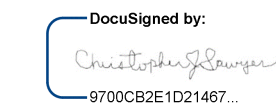
DocuSigned by:

 9700C82E1D21467

Professional Land Surveyor L-4526

PROJECT REFERENCE NO. W-5703Q	SHEET NO. RW02D-1
Location and Surveys	
DIVISION 3 LOCATION AND SURVEY'S UNIT 5310 BARBADOS BLVD, SUITE 102 CASTLE HAYNE, NORTH CAROLINA 28429	
PROJECT SURVEYOR 	
DOCUMENT NOT CONSIDERED FINAL UNLESS ALL SIGNATURES COMPLETED	

REVISIONS

C:\FEB-2022_09-04
 S:\Users\jls\Documents\MISC-INTERSTATE\Misc\Brunswick\W57030.LS-289836
 m\diva1.LS-289836

L

TYPE	STATION	NORTH	EAST
POT	10+00.00	111999.6437	2145649.3481
PC	19+34.38	112786.3699	2145145.2380
PT	26+21.62	113385.8374	2144810.0108
POT	26+77.58	113436.2217	2144785.6778

Y1

TYPE	STATION	NORTH	EAST
POT	10+00.00	111854.4265	2145019.6461
PC	14+70.34	112323.8567	2145048.9367
PT	17+51.93	112557.7673	2145186.5004
POT	18+40.52	112605.5640	2145261.0929

DR

TYPE	STATION	NORTH	EAST
POT	10+00.00	112489.3868	2145111.5724
PC	10+32.06	112509.0714	2145086.2703
PT	10+56.87	112517.4673	2145063.3385
PC	10+97.81	112519.1352	2145022.4387
PT	11+45.60	112550.9982	2144993.7205
POT	12+00.06	112605.3519	2144997.1478

NOTES:

1. PROJECT CONTROL WAS ESTABLISHED USING GNSS, THE GLOBAL NAVIGATION SATELLITE SYSTEM.
2. THE PROPOSED ALIGNMENT CONTROL DATA FOR THIS PROJECT HAS BEEN COMPILED FROM VARIOUS SOURCES. IF FURTHER INFORMATION REGARDING PROJECT CONTROL IS NEEDED, PLEASE CONTACT THE LOCATION AND SURVEYS UNIT.

RIGHT OF WAY CONTROL SHEET

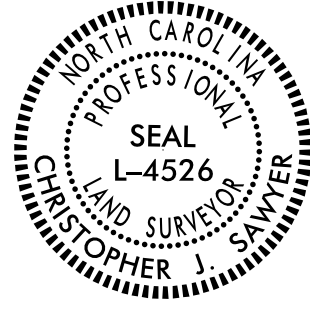
PROJECT REFERENCE NO. W-5703Q	SHEET NO. RW03E-1
Location and Surveys	
DIVISION 3 LOCATION AND SURVEYS UNIT 5310 BARBADOS BLVD, SUITE 102 CASTLE HAYNE, NORTH CAROLINA 28429	
PROJECT SURVEYOR 	
DOCUMENT NOT CONSIDERED FINAL UNLESS ALL SIGNATURES COMPLETED	

I, CHRISTOPHER J SAWYER, certify that the right of way and permanent easement monumentation for this project shown herein was completed under my direct and responsible charge from an actual survey made under my supervision; that all horizontal closures had a minimum ratio of precision of 1:10,000 (Class A). Field work was performed from January 4, 2022, and all coordinates are based on NAD83/2011; That this survey was performed to meet the requirements of 21NCAC 56.1600 as applicable.

This 4th day of February, 2022.

 Professional Land Surveyor L-4525

ROW MARKER IRON PIN AND CAP-E

ALIGN	STATION	OFFSET	NORTH	EAST
L	16+47.00	-50.00	112517.4272	2145258.1842

ROW MARKER IRON PIN AND CAP-E

ALIGN	STATION	OFFSET	NORTH	EAST
Y1	13+25.00	40.00	112176.3047	2145079.8078
Y1	13+25.00	30.00	112176.9275	2145069.8272
Y1	14+70.34	40.00	112321.3657	2145088.8590
Y1	17+51.93	40.00	112524.0883	2145208.0810

ROW MARKER PERMANENT EASEMENT-E

ALIGN	STATION	OFFSET	NORTH	EAST
Y1	13+15.00	-45.00	112171.6175	2144994.3500
Y1	13+15.00	-30.00	112170.6834	2145009.3209
Y1	14+75.00	-52.00	112332.5456	2144997.4202
Y1	15+30.00	-55.00	112396.8397	2145005.3931
Y1	16+00.00	-63.42	112477.6499	2145028.4744

NOTES:

1. IF FURTHER INFORMATION REGARDING PROJECT CONTROL IS NEEDED PLEASE CONTACT THE LOCATION AND SURVEYS UNIT.
2. PROJECT CONTROL WAS ESTABLISHED USING GNSS, THE GLOBAL NAVIGATION SATELLITE SYSTEM.

REVISIONS

Location and Surveys

DIVISION 3
LOCATION AND SURVEYS
5310 BARBADOS BLVD, SUITE 102
CASTLE HAYNE, NORTH CAROLINA 28429

PROJECT SURVEYOR



DOCUMENT NOT CONSIDERED FINAL
UNLESS ALL SIGNATURES COMPLETED

I, CHRISTOPHER J. SAWER, PLS, certify that the right of way and permanent easement monumentation for this project shown herein was completed under my direct and responsible charge from an actual survey made under my supervision; that all horizontal closures had a minimum ratio of precision of 1:10,000 (Class A). Field work was performed from January 4, 2022 and all coordinates are based on NAD83/2011; That this survey was performed to meet the requirements of 21NCAC 56.1600 as applicable.

This 4th day of February, 2022.

DocuSigned by:
Christopher Sawyer
Professional Land Surveyor L-4526

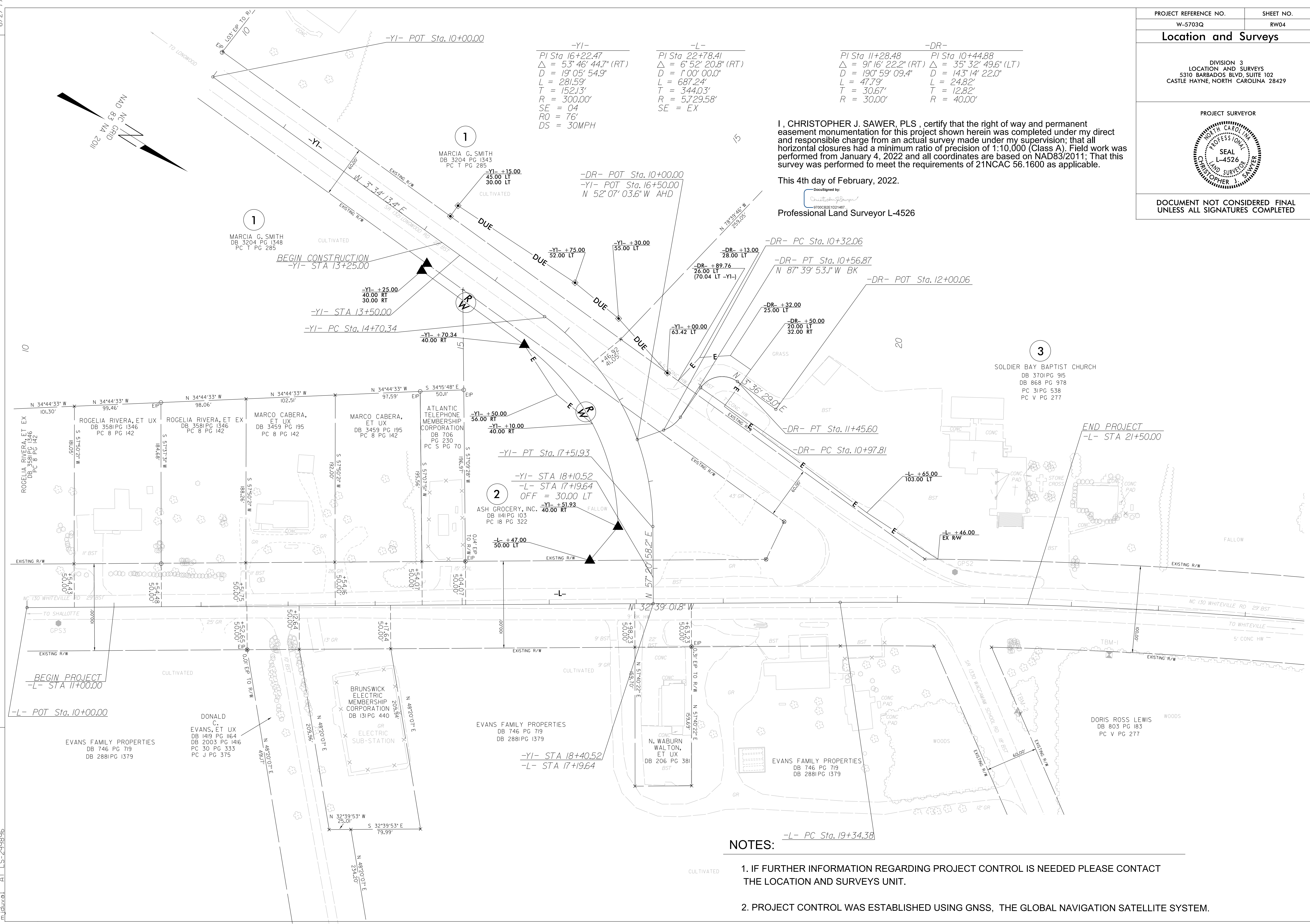

NOTES:

- IF FURTHER INFORMATION REGARDING PROJECT CONTROL IS NEEDED PLEASE CONTACT THE LOCATION AND SURVEYS UNIT.
- PROJECT CONTROL WAS ESTABLISHED USING GNSS, THE GLOBAL NAVIGATION SATELLITE SYSTEM.

REVISIONS

09-FEB-2022 10:56
 S:\Users\atl\Projects\MISC-INTERSTATE\Misc\Brunswick\W57030.LS-RW04.dgn series sheets\W57030.LS-RW04.dgn
 6/2/19

STATE OF NORTH CAROLINA
DIVISION OF HIGHWAYS

TRANSPORTATION MANAGEMENT PLAN

BRUNSWICK COUNTY

INTERSECTION OF NC 130 (WHITEVILLE RD.) AT SR 1321 (LONGWOOD RD.)

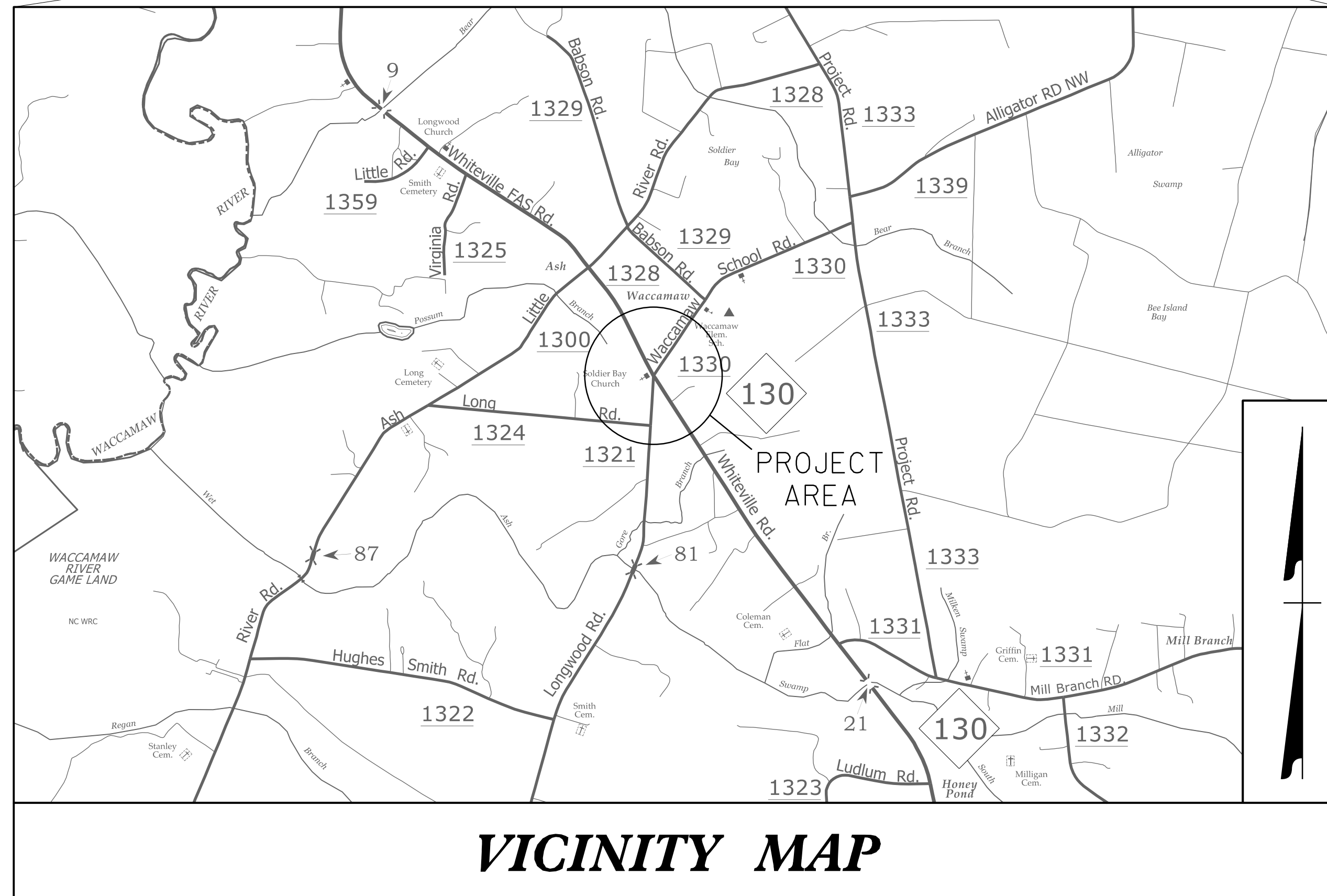
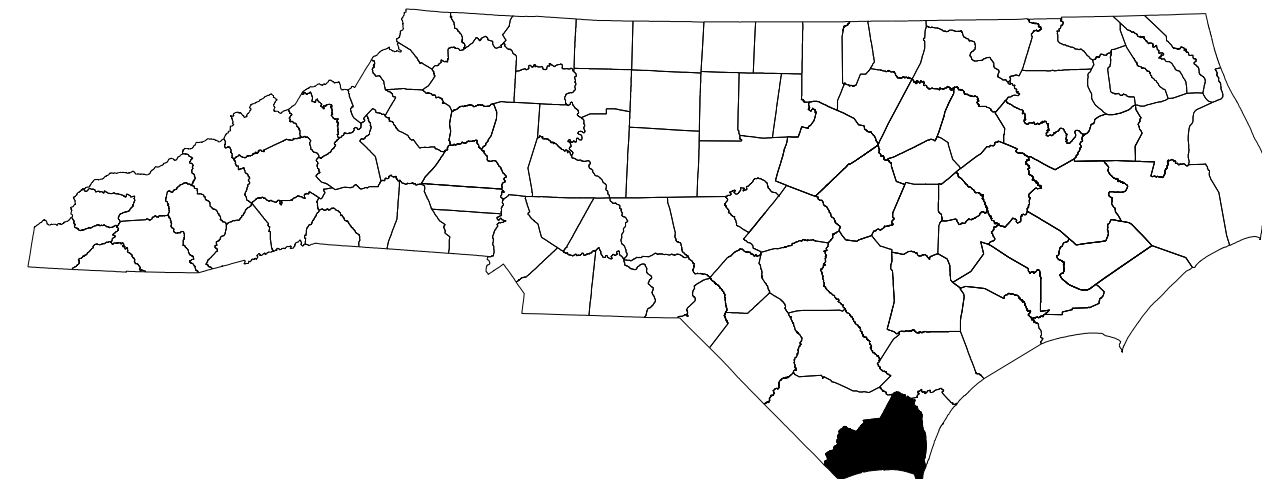

VICINITY MAP

INDEX OF SHEETS	
<u>SHEET NO.</u>	<u>TITLE</u>
TMP-1	TITLE SHEET, VICINITY MAP, AND INDEX OF SHEETS
TMP-1A	LIST OF APPLICABLE ROADWAY STANDARD DRAWINGS, AND LEGEND
TMP-1B	TRANSPORTATION OPERATIONS PLAN: (GENERAL NOTES)
TMP-1C	GENERAL NOTES, MANAGEMENT STRATEGIES, PHASING
TMP-2 TO 4	DETAIL SHEETS

SHEET NO.
TMP-1

W-5703Q

TIP PROJECT:

**DOCUMENT NOT CONSIDERED FINAL
UNLESS ALL SIGNATURES COMPLETED**

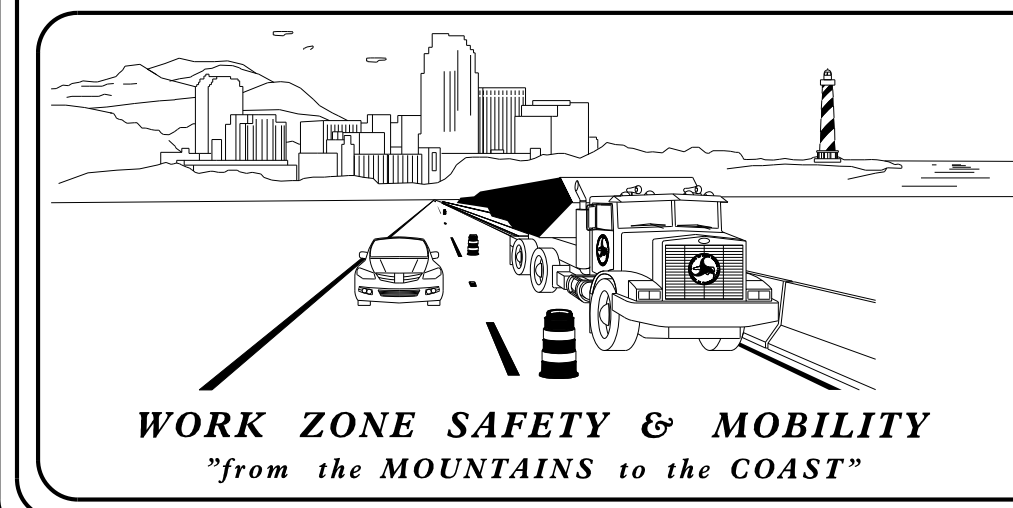

PLANS PREPARED BY:

BRANDON W. JOHNSON, P.E.
TRAFFIC CONTROL PROJECT ENGINEER

FAITH E. JAHNKE, PE
TRAFFIC CONTROL DESIGNER

NCDOT CONTACTS:

PROJECT ENGINEER

PROJECT DESIGN ENGINEER

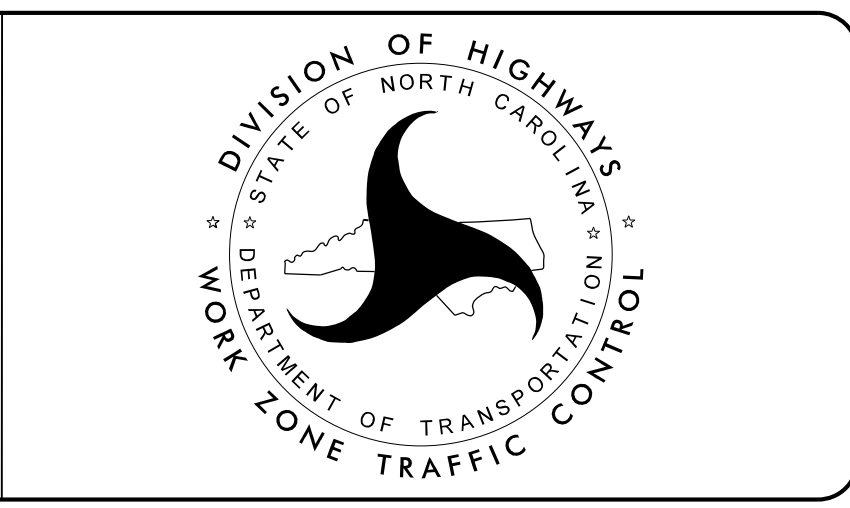

Prepared in the Office of:

SUMMIT
DESIGN AND ENGINEERING SERVICES

NC FIRM LICENSE No: P-0339
320 Executive Ct.
Hillsborough, NC 27278
(919) 732-3883
(919) 732-6676 (FAX)

APPROVED: Brandon W. Johnson

DATE: 3/9/2022

SEAL

03-MAR-2022 10:27
SS4903_Tc_TMP1.dgn
faith.jahnke

ROADWAY STANDARD DRAWINGS

THE FOLLOWING ROADWAY STANDARDS AS SHOWN IN "ROADWAY STANDARD DRAWINGS" - N.C. DEPARTMENT OF TRANSPORTATION - RALEIGH, N.C., DATED JANUARY 2018 ARE APPLICABLE TO THIS PROJECT AND BY REFERENCE HEREBY ARE CONSIDERED A PART OF THESE PLANS:

<u>STD. NO.</u>	<u>TITLE</u>
1101.01	WORK ZONE ADVANCE WARNING SIGNS
1101.02	TEMPORARY LANE CLOSURES
1101.11	TRAFFIC CONTROL DESIGN TABLES
1110.01	STATIONARY WORK ZONE SIGNS
1110.02	PORTABLE WORK ZONE SIGNS
1130.01	DRUM
1135.01	CONES
1145.01	BARRICADES
1150.01	FLAGGING DEVICES
1180.01	SKINNY-DRUM
1205.01	PAVEMENT MARKINGS - LINE TYPES AND OFFSETS
1205.02	PAVEMENT MARKINGS - TWO-LANE AND MULTI-LANE ROADWAYS
1205.04	PAVEMENT MARKINGS - INTERSECTIONS
1205.05	PAVEMENT MARKINGS - TURN LANES
1205.08	PAVEMENT MARKINGS - SYMBOLS AND WORD MESSAGES
1205.09	PAVEMENT MARKINGS - PAINTED ISLANDS
1250.01	RAISED PAVEMENT MARKERS - INSTALLATION SPACING
1251.01	RAISED PAVEMENT MARKERS - PERMANENT AND TEMPORARY

LEGEND

GENERAL

- DIRECTION OF TRAFFIC FLOW
- DIRECTION OF PEDESTRIAN TRAFFIC FLOW
- EXIST. PVMT.
- NORTH ARROW
- PROPOSED PVMT.
- TEMP. SHORING (LOCATION PURPOSES ONLY)
- WORK AREA
- REMOVAL

TEMPORARY PAVEMENT MARKING

<u>SYMBOL</u>	<u>DESCRIPTION</u>
PAINT (4")	
PA	WHITE EDGE LINE
PD	3'-9" WHITE MINI-SKIP
PE	WHITE SOLID LANE LINE
PF	10 FT YELLOW SKIP
PH	YELLOW SINGLE CENTER
PI	YELLOW DOUBLE CENTER
PAINT (8")	
PP	YELLOW DIAGONAL
QA	LEFT TURN ARROW
QB	RIGHT TURN ARROW
QC	STRAIGHT ARROW

SIGNALS

- EXISTING
- PROPOSED
- TEMPORARY

PAVEMENT MARKINGS

- EXISTING LINES
- TEMPORARY LINES

TRAFFIC CONTROL DEVICES

- BARRICADE (TYPE III)
- CONE
- DRUM SKINNY DRUM TUBULAR MARKER
- TEMPORARY CRASH CUSHION
- FLASHING ARROW BOARD
- FLAGGER
- LAW ENFORCEMENT
- TRUCK MOUNTED ATTENUATOR (TMA)
- CHANGEABLE MESSAGE SIGN

TEMPORARY SIGNING

- PORTABLE SIGN
- STATIONARY SIGN
- STATIONARY OR PORTABLE SIGN

PAVEMENT MARKERS

- CRYSTAL/CRYSTAL
- CRYSTAL/RED
- YELLOW/YELLOW

PAVEMENT MARKING SYMBOLS

- PAVEMENT MARKING SYMBOLS

APPROVED: DATE: 3/9/2022 SEAL			<h2 style="margin: 0;">ROADWAY STANDARD DRAWINGS & LEGEND</h2>
DOCUMENT NOT CONSIDERED FINAL UNLESS ALL SIGNATURES COMPLETED			

GENERAL NOTES

Prepared in the Office of:		NC FIRM LICENSE No. P-0339 320 Executive Ct. Hillsborough, NC 27278 (919) 732-3883 (919) 732-6616 (FAX)	PROJ. REFERENCE NO. W-5703Q	SHEET NO. TMP-1B
----------------------------	---	---	---------------------------------------	----------------------------

CHANGES MAY BE REQUIRED WHEN PHYSICAL DIMENSIONS IN THE DETAIL DRAWINGS, STANDARD DETAILS, AND ROADWAY DETAILS ARE NOT ATTAINABLE TO MEET FIELD CONDITIONS OR RESULT IN DUPLICATE OR UNDESIRED OVERLAPPING OF DEVICES. MODIFICATION MAY INCLUDE: MOVING, SUPPLEMENTING, COVERING, OR REMOVAL OF DEVICES AS DIRECTED BY THE ENGINEER.

THE FOLLOWING GENERAL NOTES APPLY AT ALL TIMES FOR THE DURATION OF THE CONSTRUCTION PROJECT EXCEPT WHEN OTHERWISE NOTED IN THE PLAN OR AS DIRECTED BY THE ENGINEER

TIME RESTRICTIONS

A) DO NOT CLOSE OR NARROW TRAVEL LANES AS FOLLOWS:

ROAD NAME	DAY AND TIME RESTRICTION
NC 130	FRIDAY 6:00 AM THROUGH SUNDAY 6:00 PM

BEGINNING THE FRIDAY BEFORE MEMORIAL DAY UNTIL THE SUNDAY AFTER LABOR DAY

B) DO NOT CLOSE OR NARROW TRAVEL LANES AS FOLLOWS:

ROAD NAME	NC 130
-----------	--------

HOLIDAY

1. FOR ANY UEXPECTED OCCURENCETHAT CREATES UNUSUALLY HIGH TRAFFIC VOLUMES, AS DIRECTED BY THE ENGINEER.
 2. FOR NEW YEAR'S DAY, BETWEEN THE HOURS OF 4:00 PM DECEMBER 31ST AND 6:00 PM JANUARY 2ND. IF NEW YEAR'S DAY IS ON A FRIDAY, SATURDAY, SUNDAY, OR MONDAY, THEN UNTIL 9:00 AM THE FOLLOWING TUESDAY.
 3. FOR EASTER, BETWEEN THE HOURS OF 4:00 PM THURSDAY AND 9:00 AM MONDAY.
 4. FOR MEMORIAL DAY, BETWEEN THE HOURS OF 6:00 AM FRIDAY TO 6:00 PM TUESDAY.
 5. FOR INDEPENDENCE DAY, BETWEEN THE HOURS OF 6:00 AM THE DAY BEFORE INDEPENDENCE DAY AND 6:00 PM THE DAY AFTER INDEPENDENCE DAY.
- IF INDEPENDENCE DAY IS ON A FRIDAY, SATURDAY, SUNDAY OR MONDAY THEN BETWEEN THE HOURS OF 6:00 AM THE THURSDAY BEFORE INDEPENDENCE DAY AND 6:00 PM THE TUESDAY AFTER INDEPENDENCE DAY.
6. FOR LABOR DAY, BETWEEN THE HOURS OF 6:00 AM FRIDAY AND 6:00 PM TUESDAY.
 7. FOR THANKSGIVING DAY, BETWEEN THE HOURS OF 6:00 AM TUESDAY AND 6:00 PM MONDAY.
 8. FOR CHRISTMAS, BETWEEN THE HOURS OF 4:00 PM THE FRIDAY BEFORE THE WEEK OF CHRISTMAS DAY AND 9:00 AM THE FOLLOWING TUESDAY AFTER THE WEEK OF CHRISTMAS DAY.

LANE AND SHOULDER CLOSURE REQUIREMENTS

C) REMOVE LANE CLOSURE DEVICES FROM THE LANE WHEN WORK IS NOT BEING PERFORMED BEHIND THE LANE CLOSURE OR WHEN A LANE CLOSURE IS NO LONGER NEEDED OR AS DIRECTED BY THE ENGINEER.

- D) WHEN PERSONNEL AND/OR EQUIPMENT ARE WORKING WITHIN 15 FT OF AN OPEN TRAVEL LANE, CLOSE THE NEAREST OPEN SHOULDER USING ROADWAY STANDARD DRAWING NO. 1101.04 UNLESS THE WORK AREA IS PROTECTED BY BARRIER OR GUARDRAIL OR A LANE CLOSURE IS INSTALLED.
- E) WHEN PERSONNEL AND/OR EQUIPMENT ARE WORKING ON THE SHOULDER WITHIN 5 FT ADJACENT TO AN UNDIVIDED FACILITY AND WITHIN 5 FT OF AN OPEN TRAVEL LANE, CLOSE THE NEAREST TRAVEL LANE USING ROADWAY STANDARD DRAWING NO. 1101.02 UNLESS THE WORK AREA IS PROTECTED BY BARRIER OR GUARDRAIL.
- F) WHEN PERSONNEL AND/OR EQUIPMENT ARE WORKING WITHIN A LANE OF TRAVEL OF AN UNDIVIDED OR DIVIDED FACILITY, CLOSE THE LANE ACCORDING TO THE TRAFFIC CONTROL PLANS, ROADWAY STANDARD DRAWINGS, OR AS DIRECTED BY THE ENGINEER. CONDUCT THE WORK SO THAT ALL PERSONNEL AND/OR EQUIPMENT REMAIN WITHIN THE CLOSED TRAVEL LANE.
- G) DO NOT WORK SIMULTANEOUSLY WITHIN 15 FT ON BOTH SIDES OF AN OPEN TRAVELWAY, RAMP, OR LOOP WITHIN THE SAME LOCATION UNLESS PROTECTED WITH GUARDRAIL OR BARRIER.

PAVEMENT EDGE DROP OFF REQUIREMENTS

H) BACKFILL AT A 6:1 SLOPE UP TO THE EDGE AND ELEVATION OF EXISTING PAVEMENT IN AREAS ADJACENT TO AN OPENED TRAVEL LANE THAT HAS EDGE OF PAVEMENT DROP-OFF AS FOLLOWS:

BACKFILL DROP-OFFS THAT EXCEED 2 INCHES ON ROADWAYS WITH POSTED SPEED LIMITS OF 45 MPH OR GREATER.

BACKFILL WITH SUITABLE COMPACTED MATERIAL, AS APPROVED BY THE ENGINEER, AT NO EXPENSE TO THE DEPARTMENT.

I) DO NOT EXCEED A DIFFERENCE OF 2 INCHES IN ELEVATION BETWEEN OPEN LANES OF TRAFFIC FOR NORMAL LIFTS OF 1.5 INCHES. INSTALL ADVANCE WARNING "UNEVEN LANES" SIGNS (W8-11) 500 FEET IN ADVANCE.

TRAFFIC PATTERN ALTERATIONS

J) NOTIFY THE ENGINEER THIRTY (30) CALENDAR DAYS PRIOR TO ANY TRAFFIC PATTERN ALTERATION.

SIGNING

- K) INSTALL ADVANCE WORK ZONE WARNING SIGNS WHEN WORK IS WITHIN 40 FT FROM THE EDGE OF TRAVEL LANE AND NO MORE THAN THREE (3) DAYS PRIOR TO THE BEGINNING OF CONSTRUCTION.
- L) ENSURE ALL NECESSARY SIGNING IS IN PLACE PRIOR TO ALTERING ANY TRAFFIC PATTERN
- M) INSTALL BLACK ON ORANGE "DIP" SIGNS (W8-2) AND/OR "BUMP" SIGNS (W8-1) 350 FT IN ADVANCE OF THE UNEVEN AREA, OR AS DIRECTED BY THE ENGINEER.

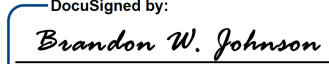
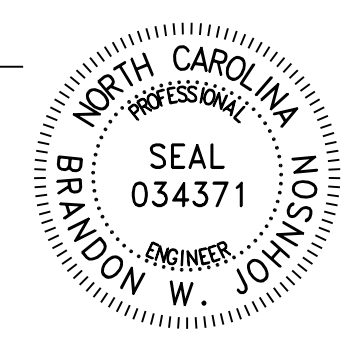
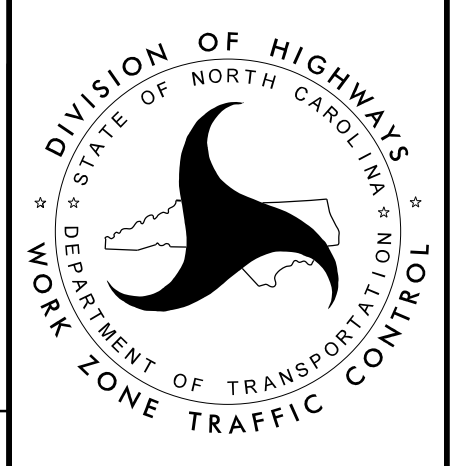
APPROVED:  DATE: 3/9/2022 SEAL 		TRANSPORTATION OPERATIONS PLAN
DOCUMENT NOT CONSIDERED FINAL UNLESS ALL SIGNATURES COMPLETED		

GENERAL NOTES (CONTINUED)

TRAFFIC CONTROL DEVICES

- N) WHEN LANE CLOSURES ARE NOT IN EFFECT SPACE CHANNELIZING DEVICES IN WORK AREAS NO GREATER IN FEET THAN TWICE THE POSTED SPEED LIMIT (MPH), EXCEPT, 10 FT ON-CENTER IN RADII, AND 3 FT OFF THE EDGE OF AN OPEN TRAVELWAY, REFER TO STANDARD SPECIFICATIONS FOR ROADS AND STRUCTURES SECTIONS 1130 (DRUMS), 1135 (CONES) AND 1180 (SKINNY DRUMS) FOR ADDITIONAL REQUIREMENTS.
- O) PLACE TYPE III BARRICADES WITH "ROAD CLOSED" SIGN R11-2 ATTACHED OF SUFFICIENT LENGTH TO CLOSE ENTIRE ROADWAY.

PAVEMENT MARKINGS AND MARKERS

- P) INSTALL TEMPORARY PAVEMENT MARKING AND TEMPORARY PAVEMENT MARKERS ON INTERIM LAYERS OF PAVEMENT AS FOLLOWS:

ROAD NAME	MARKING	MARKER
ALL	PAINT	TEMP RAISED

- Q) PLACE ONE APPLICATION OF PAINT FOR TEMPORARY TRAFFIC PATTERNS. PLACE A SECOND APPLICATION OF PAINT SIX (6) MONTHS AFTER THE INITIAL APPLICATION AND EVERY SIX MONTHS AS DIRECTED BY THE ENGINEER.
- R) TIE PROPOSED PAVEMENT MARKING LINES TO EXISTING PAVEMENT MARKING LINES.
- S) REMOVE/REPLACE ANY CONFLICTING/DAMAGED PAVEMENT MARKINGS AND MARKERS BY THE END OF EACH DAY'S OPERATION.

MANAGEMENT STRATEGY

TRAFFIC WILL BE MANAGED WITH LANE CLOSURES USING FLAGGERS. FLAGGERS WILL BE USED ON ALL APPROACHES TO THE INTERSECTION OF NC 130, SR 1321 AND WACCAMAW SCHOOL ROAD TO PREVENT CONFLICTING MOVEMENTS. LANE CLOSURES WILL NOT BE ALLOWED BEGINNING FRIDAY AT 6:00 AM THROUGH SUNDAY AT 6:00 PM STARTING THE WEEKEND OF MEMORIAL DAY AND ENDING THE WEEKEND OF LABOR DAY DUE TO WEEKEND BEACH TRAFFIC.

PHASING

AT THE END OF EACH DAY'S OPERATION, THE CONTRACTOR SHALL MAINTAIN SOLDIER BAY BAPTIST CHURCH'S DRIVE (-DR-) WITH A TEMPORARY TIE-IN IF NECESSARY.

PHASE I

STEP 1

USE RSD 1101.01 SHEET 3 OF 3 TO PLACE WORK ZONE ADVANCE WARNING SIGNS ON -L- (NC 130), -Y1- (LONGWOOD ROAD) AND SR 1330 (WACCAMAW SCHOOL RD).

STEP 2

USE RSD 1101.02 SHEET 1 OF 14 AND ALTERNATE LANE CLOSURES TO CONSTRUCT PROPOSED DRAINAGE CROSS PIPES.

USE RSD 1101.02 SHEET 1 OF 14 TO CLOSE A LANE AND CONSTRUCT -L- WIDENING FROM STA 11+00 +/- TO 21+50 +/- UP TO THE EXISTING EDGE AND ELEVATION.

CONSTRUCT -Y1- FROM STA 16+00 +/- TO 18+22 +/- UP TO THE EXISTING EDGE AND ELEVATION OF PAVEMENT ON -L- AND -Y1-. WHEN CONSTRUCTION IS WITHIN 5 FEET OF A LIVE LANE OF TRAFFIC USE RSD 1101.02 SHEET 1 OF 14 TO CLOSE THE NEAREST LANE. SEE TMP-2

NOTE: ADDITIONAL FLAGGERS WILL BE NEEDED AT THE INTERSECTION OF SR 1330 (WACCAMAW SCHOOL ROAD) AND -Y1- (LONGWOOD RD) TO COORDINATE TURNING TRAFFIC WHEN THE LANE CLOSURE ON NC 130 EXTENDS THROUGH THE INTERSECTION.

STEPS 3 AND 4 MUST BE COMPLETED IN A CONTINUOUS OPERATION

STEP 3

USE RSD 1101.02 SHEET 1 OF 14 TO CLOSE THE RIGHT (INSIDE) 12' LANE OF -Y1- AND WEDGE FROM STA 13+50 +/- TO 18+22 +/- UP TO BUT NOT INCLUDING THE FINAL LAYER OF SURFACE COURSE AS SHOWN ON SHEET TMP-3

STEP 4

PLACE TRAFFIC IN A ONE-LANE TWO-WAY TRAFFIC PATTERN ON THE NEWLY CONSTRUCTED 12' RIGHT LANE OF -Y1-.

CLOSE EXISTING -Y1- AS SHOWN ON SHEET TMP-4.

WEDGE THE LEFT (OUTSIDE) 12' LANE OF -Y1- UP TO BUT NOT INCLUDING THE FINAL LAYER OF SURFACE COURSE AND PLACE TEMPORARY PAVEMENT MARKING AS SHOWN ON SHEET TMP-4



REMOVE EXISTING FLASHING SIGNAL.

STEP 5

USE RSD 1101.02 SHEET 1 OF 14 TO COMPLETE PAVING ON -L- (NC 130) AND -Y1- (LONGWOOD ROAD) UP THROUGH THE FINAL LAYER OF SURFACE COURSE. REPLACE PAVEMENT MARKING AND TIE TO EXISTING AT THE END OF EACH DAY'S OPERATION.

STEP 6

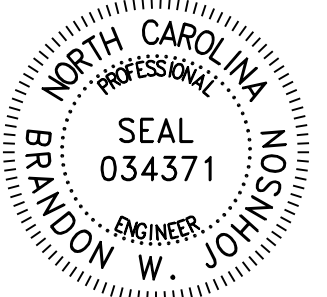
USE RSD 1101.02 SHEET 11 OF 14 TO PLACE FINAL PAVEMENT MARKING (THERMOPLASTIC) AND RAISED MARKERS ON -L- (NC 130) AND -Y1- (LONGWOOD ROAD) AS SHOWN ON SHEET PM-2

<p>APPROVED: </p> <p>DATE: 3/15/2022</p> <p style="text-align: center;">SEAL</p> <p style="text-align: center;"></p>		<p>TRANSPORTATION OPERATIONS PLAN</p>
<p>DOCUMENT NOT CONSIDERED FINAL UNLESS ALL SIGNATURES COMPLETED</p>		

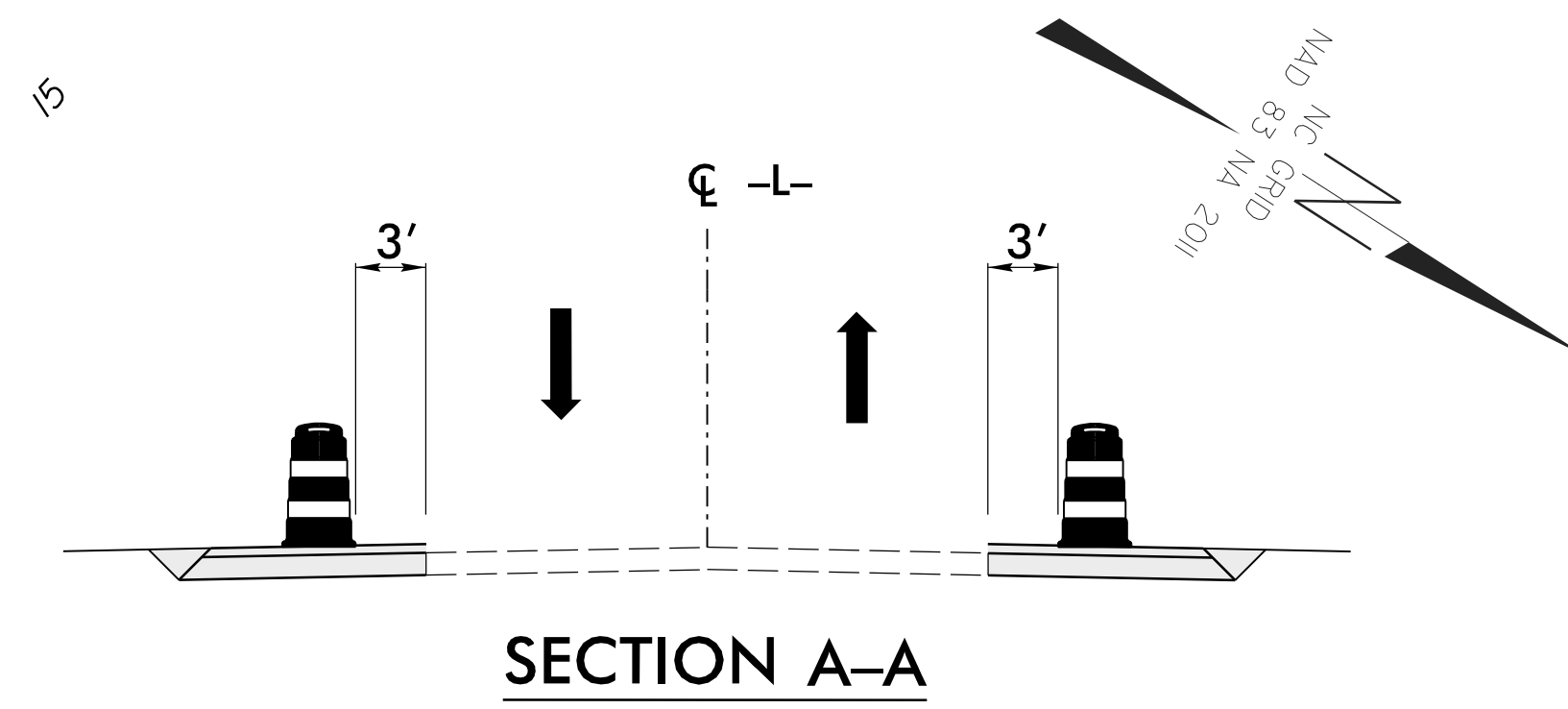
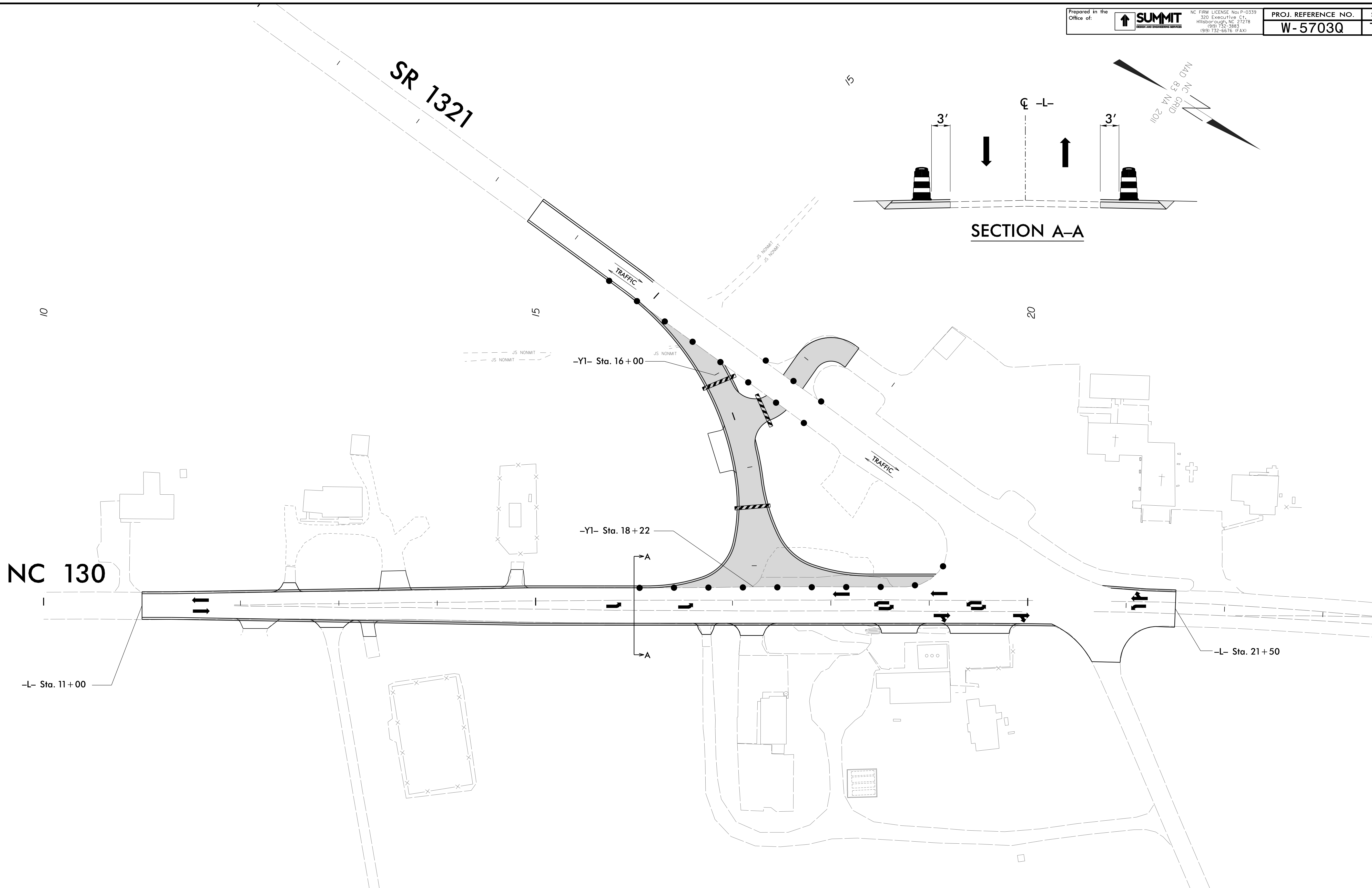

SECTION A-A

03-MAR-2022 10:27
SS4903_TC_TMP:2.dgn
faith.jahnke

APPROVED: *Beauden W. Johnson*
DATE: 3/9/2022

SEAL

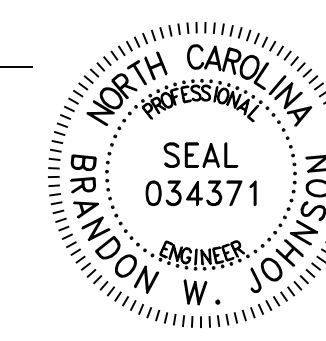

**DOCUMENT NOT CONSIDERED FINAL
UNLESS ALL SIGNATURES COMPLETED**

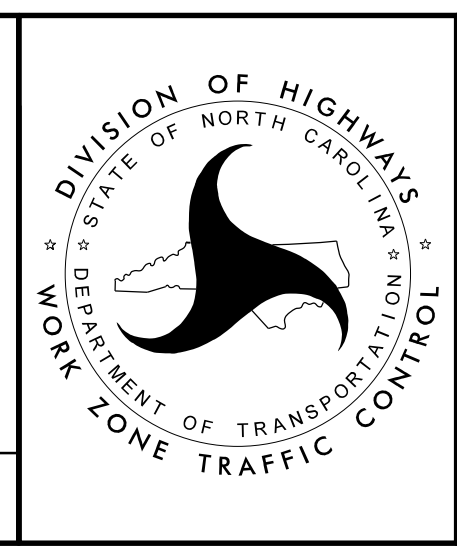

DETAIL SHEET
STEP 2

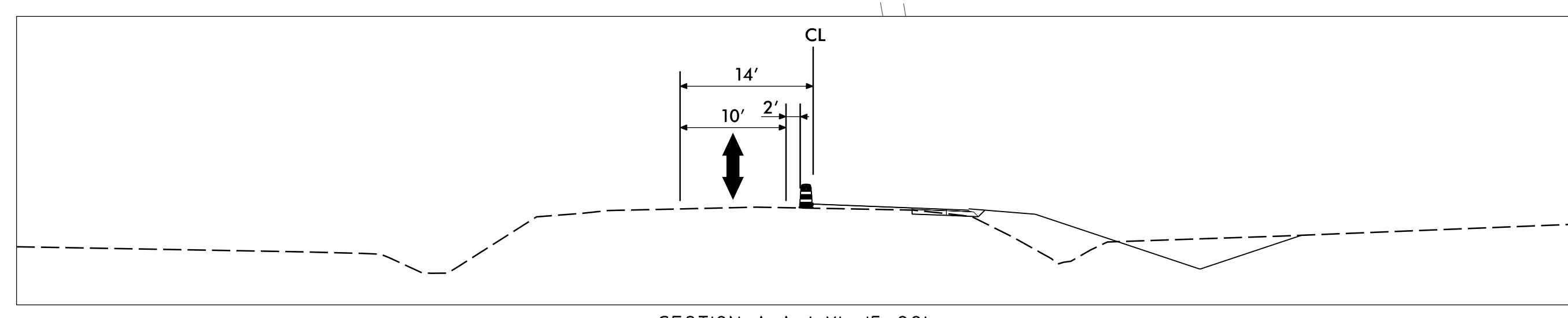
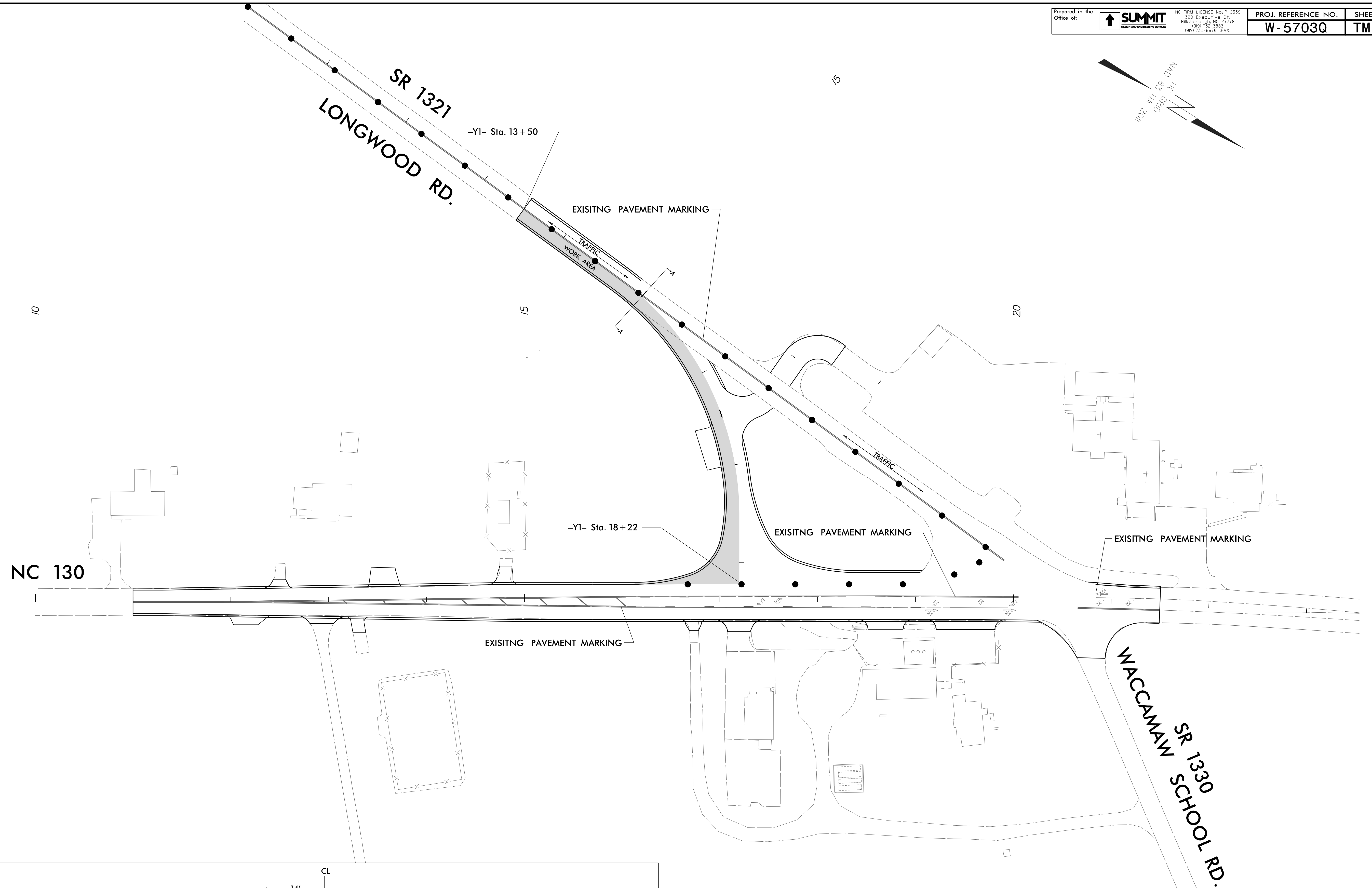

APPROVED: *Brandon W. Johnson*
6A29A2BEC0845E...
 DATE: 3/9/2022

SEAL

BRANDON W. JOHNSON
 NORTH CAROLINA
 PROFESSIONAL ENGINEER
 SEAL 034371

**DOCUMENT NOT CONSIDERED FINAL
 UNLESS ALL SIGNATURES COMPLETED**

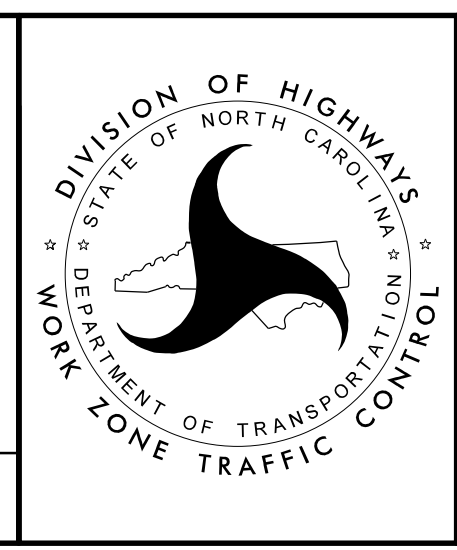

**DETAIL SHEET
 STEP 3**

03-MAR-2022 10:27
 SS4903_TC_TMP-3.dgn
 faith.jahnke

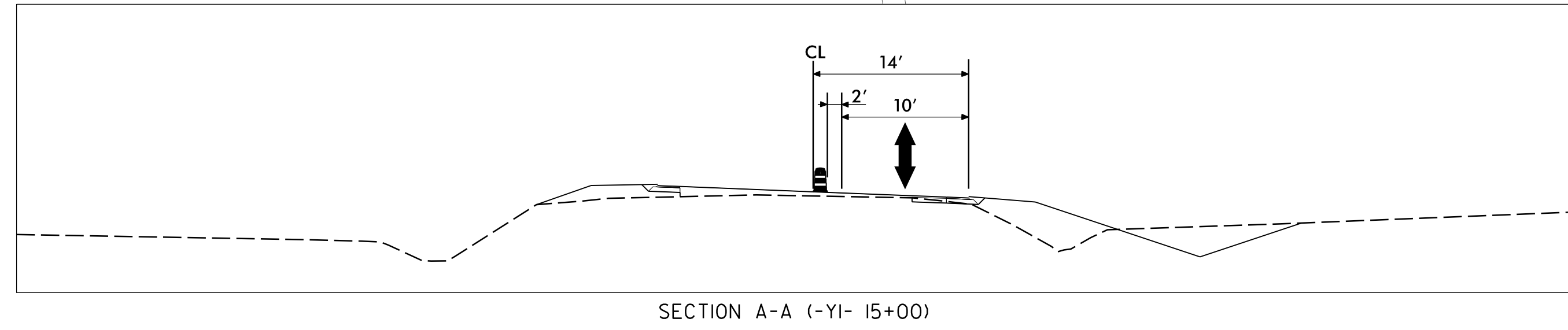
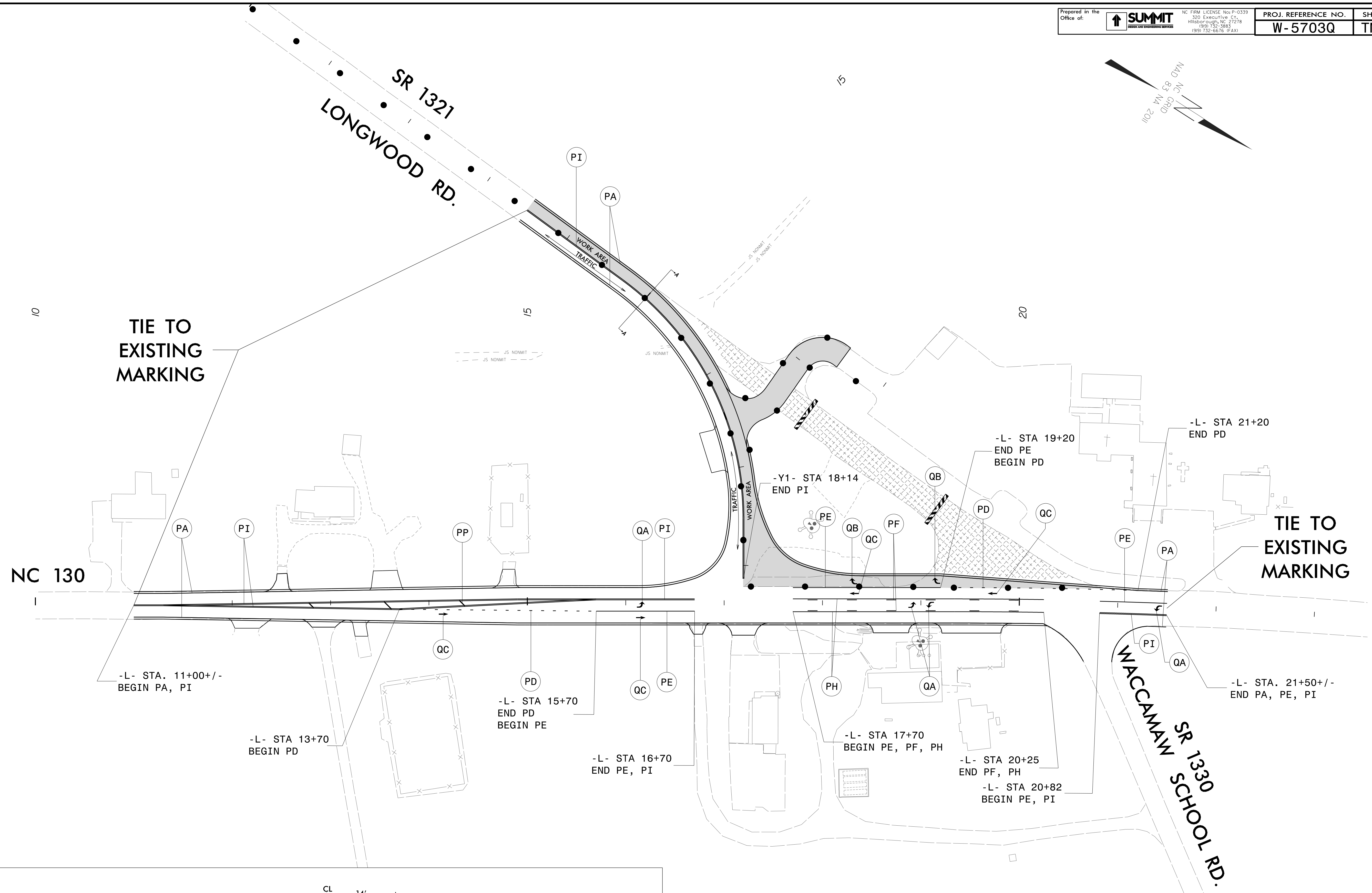
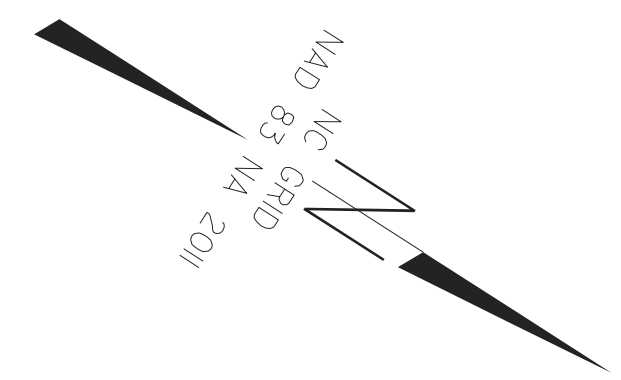

APPROVED: *Brandon W. Johnson*
DATE: 3/9/2022

SEAL

BRANDON W. JOHNSON
NORTH CAROLINA PROFESSIONAL ENGINEER
SEAL 034371

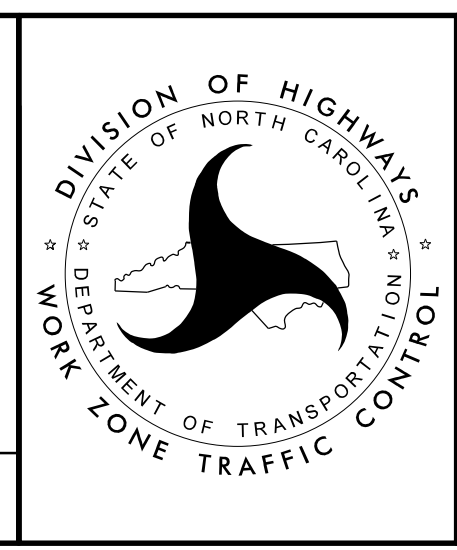

**DETAIL SHEET
STEP 4**

03-MAR-2022 10:27
SS4903_TC_TMP_4.dgn
faith.jahnke

**DOCUMENT NOT CONSIDERED FINAL
UNLESS ALL SIGNATURES COMPLETED**

PROJECT: W-5703Q

CONTRACT: DC00337

STATE OF NORTH CAROLINA
DIVISION OF HIGHWAYS

BRUNSWICK COUNTY

**LOCATION: INTERSECTION OF NC 130 (WHITEVILLE RD.)
AT SR 1321 (LONGWOOD RD.)**

TYPE OF WORK: GRADING, DRAINAGE, SIGNAL REMOVAL, AND PAVING.

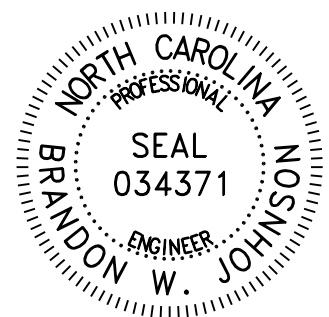
TIP NO. W-5703Q	SHEET NO. PMP-1
APPROVED: <small>DocuSigned by: Brandon W. Johnson 7529F988C7B474</small>	
DATE: 3/22/2022	
	
DOCUMENT NOT CONSIDERED FINAL UNLESS ALL SIGNATURES COMPLETED	

ROADWAY STANDARD DRAWING

THE FOLLOWING ROADWAY STANDARDS AS APPEAR IN "ROADWAY STANDARD DRAWINGS" - PROJECT SERVICES UNIT - N.C. DEPARTMENT OF TRANSPORTATION - RALEIGH, N.C., DATED JANUARY 2012 ARE APPLICABLE TO THIS PROJECT AND BY REFERENCE HEREBY ARE CONSIDERED A PART OF THESE PLANS:

STD. NO.	TITLE
1205.01	PAVEMENT MARKINGS - LINE TYPES AND OFFSETS
1205.02	PAVEMENT MARKINGS - TWO-LANE AND MULTILANE ROADWAYS
1205.04	PAVEMENT MARKINGS - INTERSECTIONS
1205.05	PAVEMENT MARKINGS - TURN LANES
1205.08	PAVEMENT MARKINGS - SYMBOLS AND WORD MESSAGES
1205.09	PAVEMENT MARKINGS - PAINTED ISLANDS
1250.01	RAISED PAVEMENT MARKERS - INSTALLATION SPACING
1251.01	RAISED PAVEMENT MARKERS - PERMANENT AND TEMPORARY
1253.01	RAISED PAVEMENT MARKERS - SNOWPLOWABLE

PROJECT W-5703Q PAVEMENT MARKING SCHEDULE

SYMBOL	DESCRIPTION
THERMO (4")	
TA	WHITE EDGE LINE
TD	3'-9' WHITE MINI-SKIP
TE	WHITE SOLID LANE LINE
TF	10 FT YELLOW SKIP
TH	YELLOW SINGLE CENTER
TI	YELLOW DOUBLE CENTER
THERMO (8")	
TP	YELLOW DIAGONAL
THERMO (24")	
T2	WHITE STOP BAR
UA	LEFT TURN ARROW
UB	RIGHT TURN ARROW
UC	STRAIGHT ARROW
SNOWPLOWABLE MARKERS (Y-Y)	
SNOWPLOWABLE MARKERS (C-R)	
RAISED MARKERS (Y-Y)	

GENERAL NOTES

THE FOLLOWING GENERAL NOTES APPLY AT ALL TIMES FOR THE DURATION OF THE CONSTRUCTION PROJECT, EXCEPT WHEN OTHERWISE NOTED IN THE PLAN OR DIRECTED BY THE ENGINEER.

- A) INSTALL PAVEMENT MARKINGS AND PAVEMENT MARKERS ON THE FINAL SURFACE AS FOLLOWS:

ROAD NAME	MARKING	MARKER
NC 130	THERMO	SNOWPLOWABLE
SR 1321	THERMO	RAISED

- B) TIE PROPOSED PAVEMENT MARKING LINES TO EXISTING PAVEMENT MARKING LINES.
- C) REMOVE/REPLACE ANY CONFLICTING/DAMAGED PAVEMENT MARKINGS AND MARKERS.
- D) PASSING ZONES WILL BE DETERMINED IN THE FIELD AND MUST BE APPROVED BY THE ENGINEER.
- E) UNLESS OTHERWISE SPECIFIED, HEATED IN-PLACE THERMOPLASTIC MAY BE USED IN LIEU OF EXTRUDED THERMOPLASTIC FOR STOP BARS, CHARACTERS AND DIAGONALS. IF HEATED IN-PLACE IS USED, IT SHALL BE PAID FOR USING THE EXTRUDED THERMOPLASTIC PAY ITEM.

Prepared in the Office of:

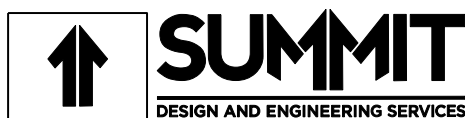

NC FIRM LICENSE No: P-0339
320 Executive Ct.
Hillsborough, NC 27278
(919) 732-3883
(919) 732-6676 (FAX)

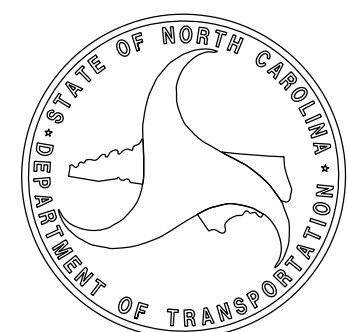

BRANDON W. JOHNSON, PE PROJECT ENGINEER

FAITH E. JAHNKE, EI PROJECT DESIGNER

INDEX

- PMP-1 PAVEMENT MARKING PLAN TITLE, SCHEDULE, AND QUANTITIES
- PMP-2 PAVEMENT MARKING DETAIL SHEETS

R.17.00

Prepared in the Office of:		NC PBM LICENSE No. P-0339 320 Executive Ct. Wilmington, NC 27278 (919) 752-3883 (919) 752-6676 (FAX)	PROJ. REFERENCE NO. W-5703Q	SHEET NO. PMP-2
----------------------------	---	--	--------------------------------	--------------------

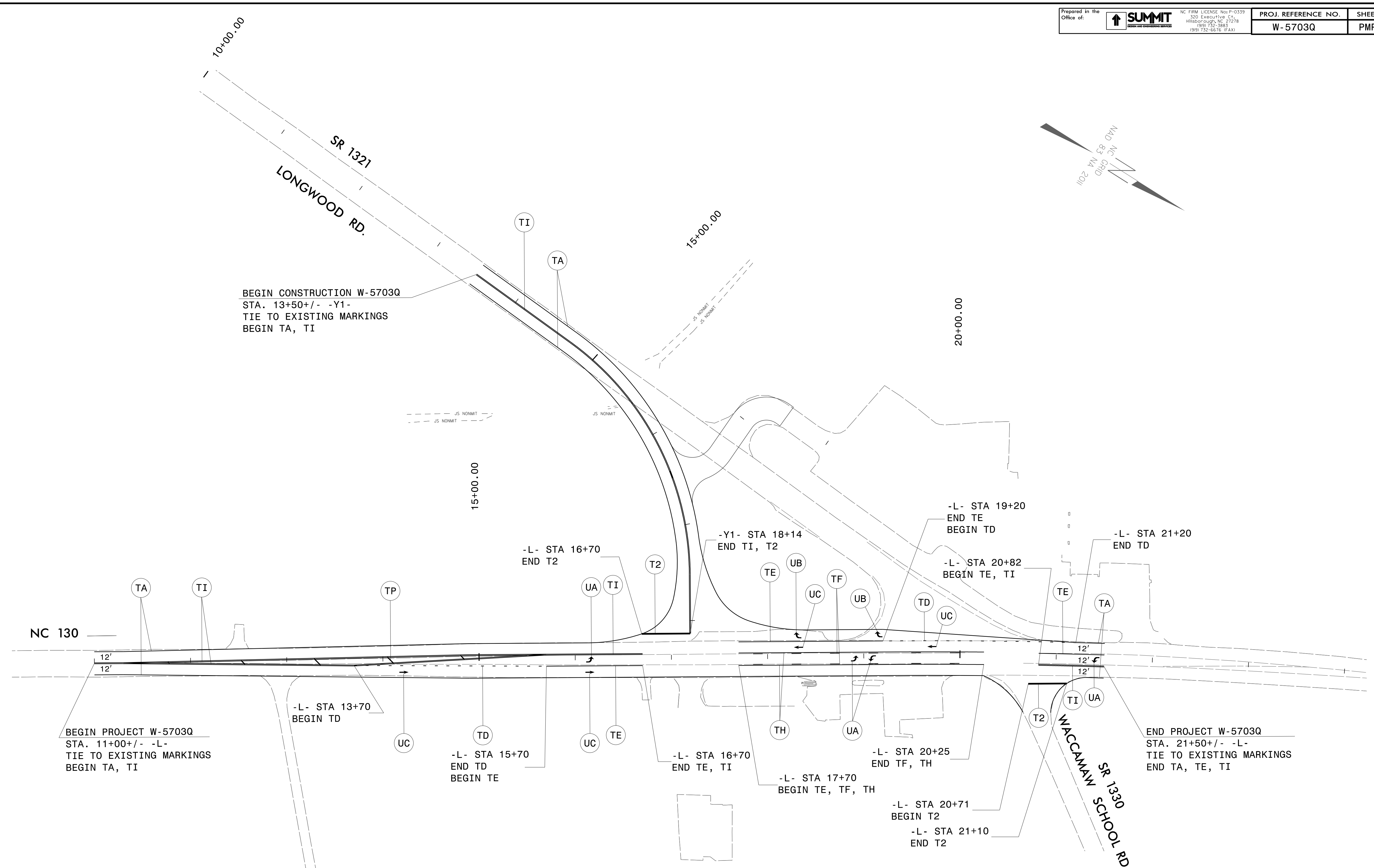

22-MAR-2022 10:11
SS4903_PMP_2.dgn
faith.jahnke

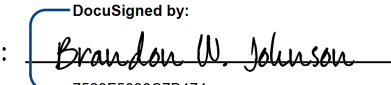
APPROVED: 
DATE: 3/22/2022

SEAL

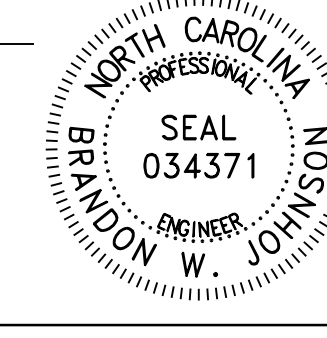

**DOCUMENT NOT CONSIDERED FINAL
UNLESS ALL SIGNATURES COMPLETED**

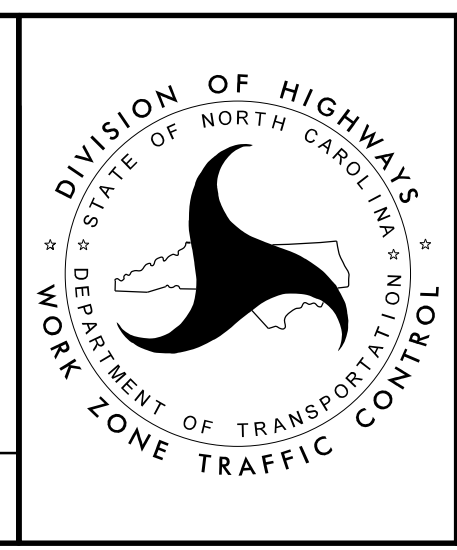

PAVEMENT MARKING
DETAIL SHEET 1

TIP PROJECT: W-5703Q

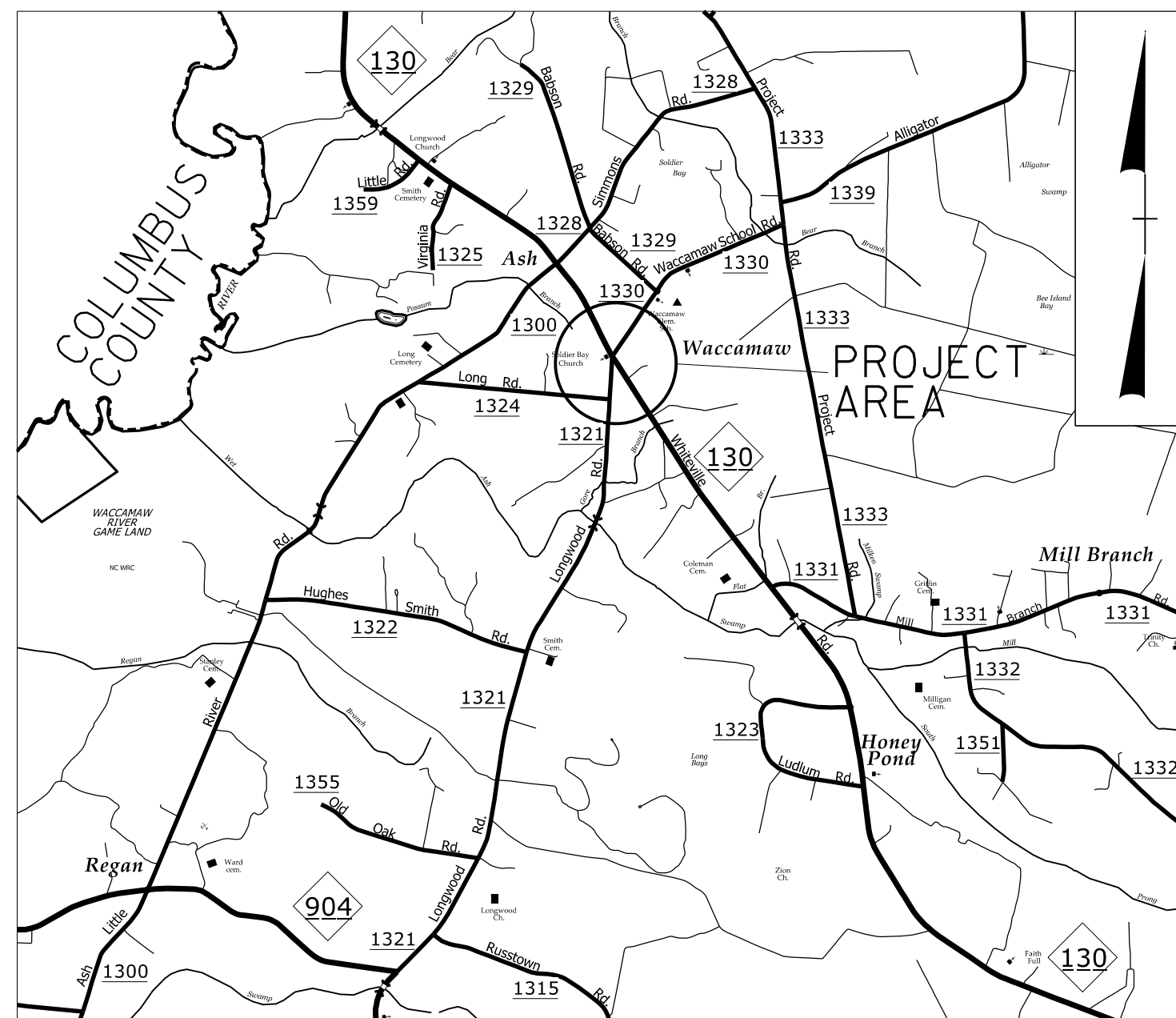

VICINITY MAP (NTS)

NOTE: THIS PROJECT IS NOT WITHIN ANY MUNICIPAL BOUNDARIES

STATE OF NORTH CAROLINA
DIVISION OF HIGHWAYS

PLAN FOR PROPOSED
HIGHWAY EROSION CONTROL

BRUNSWICK COUNTY

**LOCATION: INTERSECTION AT NC 130 (WHITEVILLE RD.)
AT SR 1321 (LONGWOOD RD.)**

TYPE OF WORK: GRADING, DRAINAGE, SIGNAL REMOVAL, AND PAVING

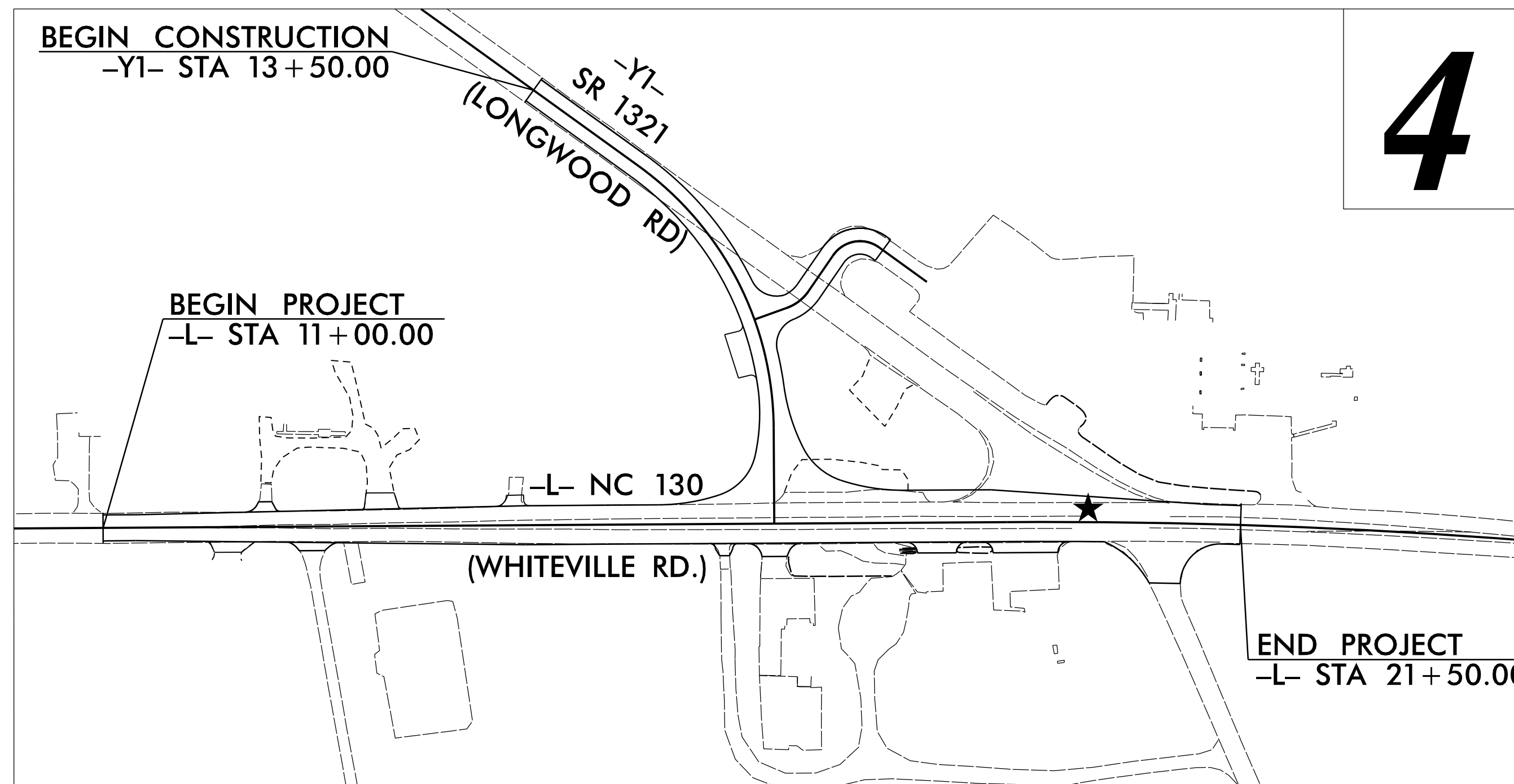

CLEARING ON THIS PROJECT SHALL BE PREFORMED TO THE LIMITS ESTABLISHED BY METHOD III.

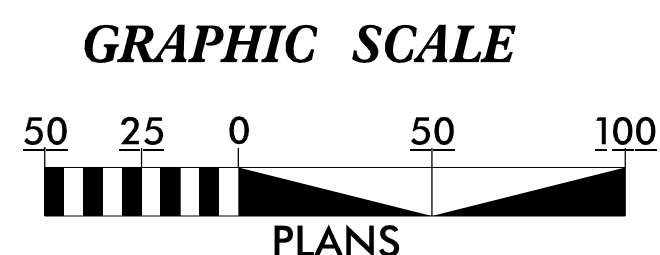

**THESE EROSION AND SEDIMENT CONTROL PLANS COMPLY WITH
THE APPLICABLE REGULATIONS SET FORTH BY THE NCG-010000
GENERAL CONSTRUCTION PERMIT EFFECTIVE APRIL 1, 2019
AND ISSUED BY THE NORTH CAROLINA DEPARTMENT OF
ENVIRONMENTAL QUALITY DIVISION OF WATER RESOURCES.**



Prepared in the Office of:
**504 Meadowland Drive
Hillsborough, NC 27278-8551**
Voice: (919)732-3883
Fax: (919)732-6776
www.summitde.net

Designed by:
HE YANG **4408**
NAME LEVEL III CERTIFICATION NO.

Roadway Standard Drawings

The following roadway english standards as appear in "Roadway Standard Drawings"- Roadway Design Unit - N. C. Department of Transportation - Raleigh, N. C., dated January 2012 and the latest revision thereto are applicable to this project and by reference hereby are considered a part of these plans.

1604.01 Railroad Erosion Control Detail	1632.01 Rock Inlet Sediment Trap Type A
1605.01 Temporary Silt Fence	1632.02 Rock Inlet Sediment Trap Type B
1606.01 Special Sediment Control Fence	1632.03 Rock Inlet Sediment Trap Type C
1607.01 Gravel Construction Entrance	1633.01 Temporary Rock Silt Check Type A
1622.01 Temporary Berms and Slope Drains	1633.02 Temporary Rock Silt Check Type B
1630.01 Riser Basin	1634.01 Temporary Rock Sediment Dam Type A
1630.02 Silt Basin Type B	1634.02 Temporary Rock Sediment Dam Type B
1630.03 Temporary Silt Ditch	1635.01 Rock Pipe Inlet Sediment Trap Type A
1630.04 Stilling Basin	1635.02 Rock Pipe Inlet Sediment Trap Type B
1630.05 Temporary Diversion	1640.01 Coir Fiber Baffle
1630.06 Special Stilling Basin	1645.01 Temporary Stream Crossing
1631.01 Matting Installation	

STATE	STATE PROJECT REFERENCE NO.	SHEET NO.	TOTAL SHEETS
N.C.	W-5703Q	EC-1	
STATE PROJ. NO.	F.A. PROJ. NO.	DESCRIPTION	

EROSION AND SEDIMENT CONTROL MEASURES

Std. #	Description	Symbol
1630.03	Temporary Silt Ditch	
1630.05	Temporary Diversion	
1605.01	Temporary Silt Fence	
1606.01	Special Sediment Control Fence	
1622.01	Temporary Berms and Slope Drains	
1630.02	Silt Basin Type B	
1633.01	Temporary Rock Silt Check Type-A	
	Temporary Rock Silt Check Type-A with Matting and Polyacrylamide (PAM)	
1633.02	Temporary Rock Silt Check Type-B	
	Wattle/ Coir Fiber Wattle	
	Wattle/ Coir Fiber Wattle with Polyacrylamide (PAM)	
1634.01	Temporary Rock Sediment Dam Type-A	
1634.02	Temporary Rock Sediment Dam Type-B	
1635.01	Rock Pipe Inlet Sediment Trap Type-A	
1635.02	Rock Pipe Inlet Sediment Trap Type-B	
1630.04	Stilling Basin	
1630.06	Special Stilling Basin	
	Rock Inlet Sediment Trap:	
1632.01	Type A	
1632.02	Type B	
1632.03	Type C	
	Skimmer Basin	
	Tiered Skimmer Basin	
	Infiltration Basin	

**THIS PROJECT CONTAINS
EROSION CONTROL PLANS
FOR CLEARING AND
GRUBBING PHASE OF
CONSTRUCTION.**

PROJECT REFERENCE NO. W-5703Q	SHEET NO. EC-2
RW SHEET NO.	
ROADWAY DESIGN ENGINEER	HYDRAULICS ENGINEER

COIR FIBER WATTLE WITH POLYACRYLAMIDE (PAM) DETAIL

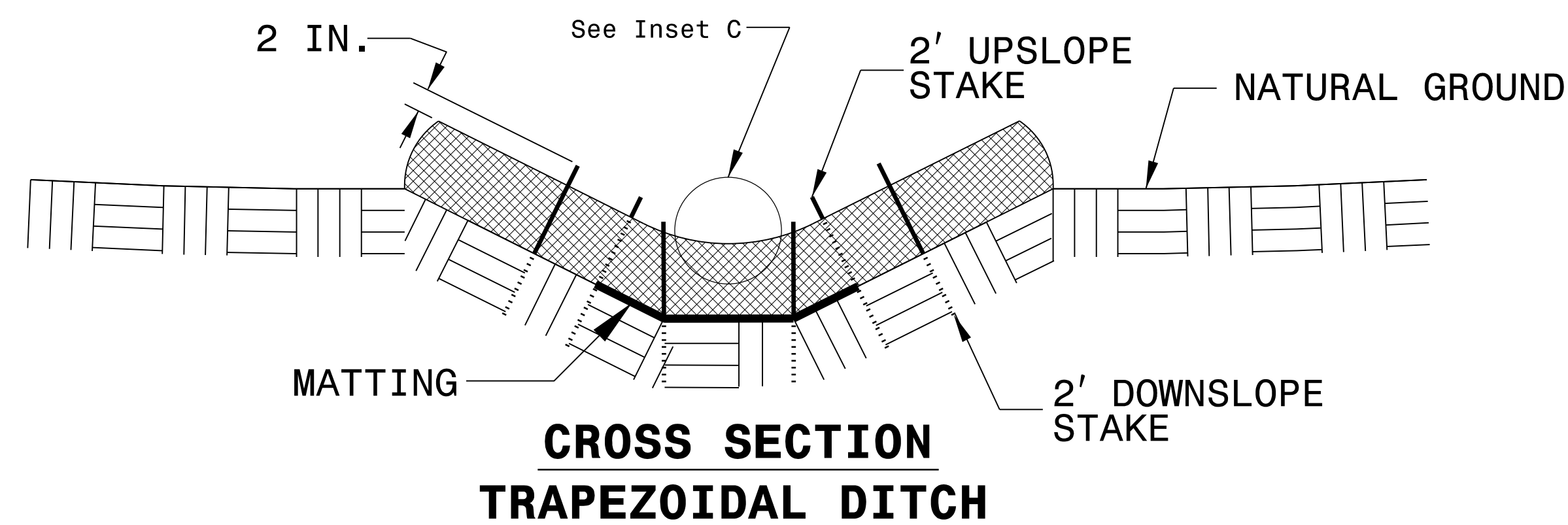
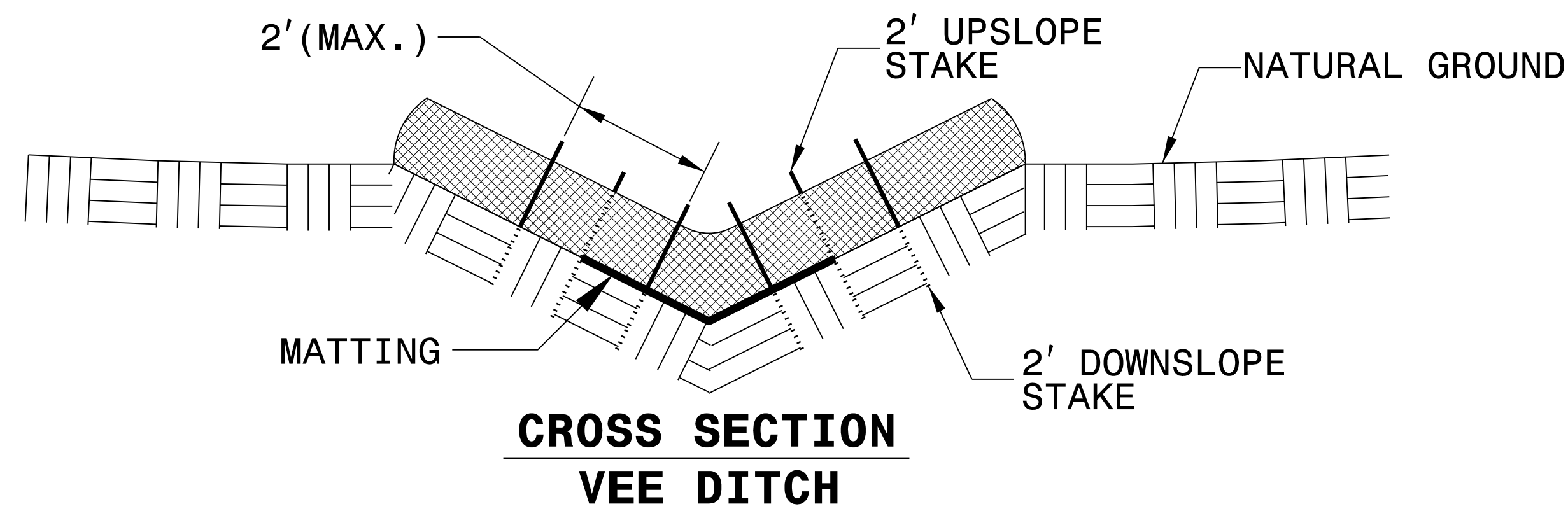
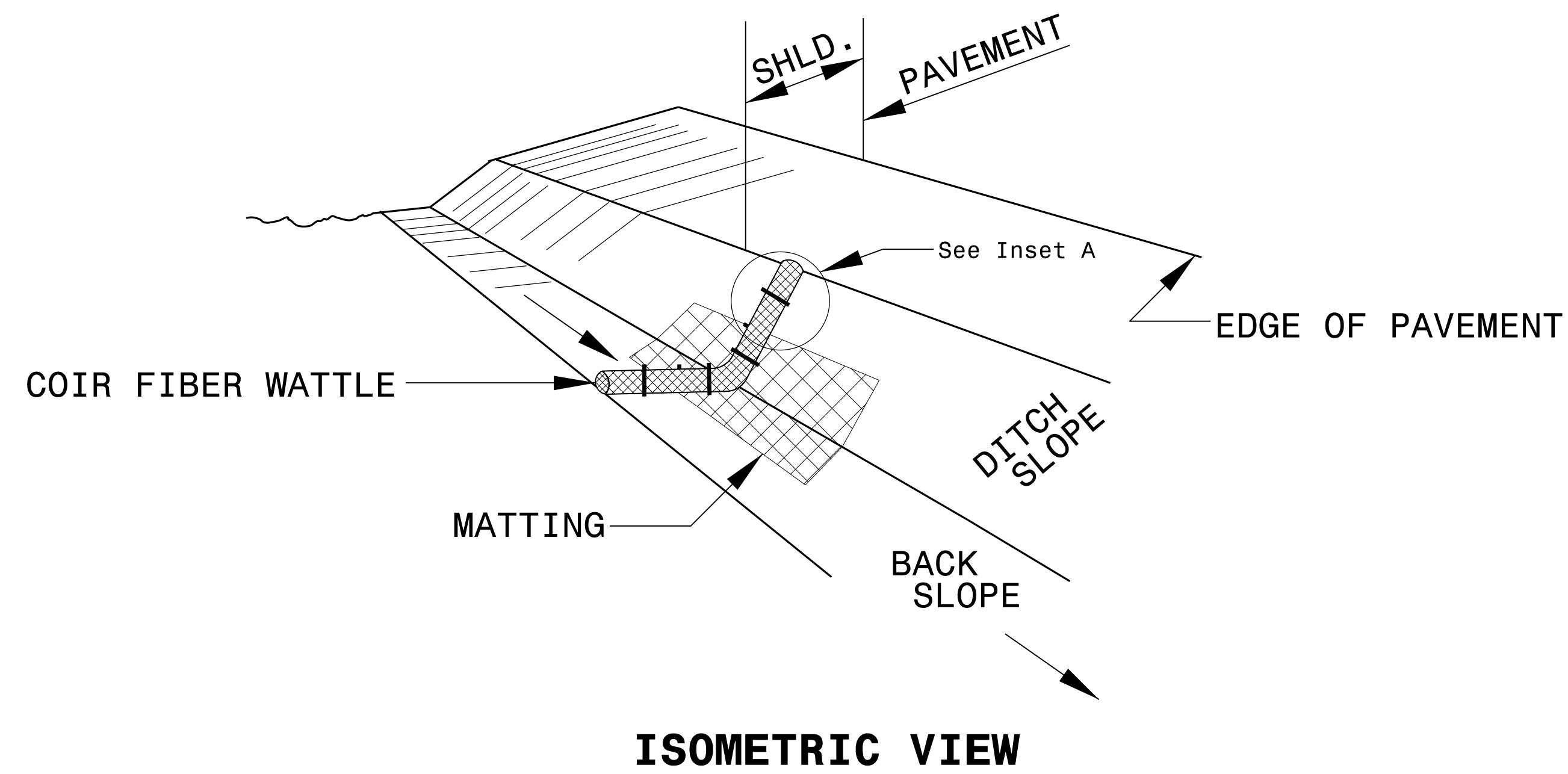

NOTES:

- USE MINIMUM 12 IN. DIAMETER COIR FIBER (COCONUT FIBER) WATTLE.
- USE 2 FT. WOODEN STAKES WITH A 2 IN. BY 2 IN. NOMINAL CROSS SECTION.
- ONLY INSTALL WATTLE(S) TO A HEIGHT IN DITCH SO FLOW WILL NOT WASH AROUND WATTLE AND SCOUR DITCH SLOPES AND AS DIRECTED.
- INSTALL A MINIMUM OF 2 UPSLOPE STAKES AND 4 DOWNSLOPE STAKES AT AN ANGLE TO WEDGE WATTLE TO BOTTOM OF DITCH.
- PROVIDE STAPLES MADE OF 0.125 IN. DIAMETER STEEL WIRE FORMED INTO A U SHAPE NOT LESS THAN 12" IN LENGTH.
- INSTALL STAPLES APPROXIMATELY EVERY 1 LINEAR FOOT ON BOTH SIDES OF WATTLE AND AT EACH END TO SECURE IT TO THE SOIL.
- INSTALL MATTING IN ACCORDANCE WITH SECTION 1631 OF THE STANDARD SPECIFICATIONS.
- PRIOR TO POLYACRYLAMIDE (PAM) APPLICATION, OBTAIN A SOIL SAMPLE FROM PROJECT LOCATION, AND FROM OFFSITE MATERIAL, AND ANALYZE FOR APPROPRIATE PAM FLOCCULANT TO BE APPLIED TO EACH WATTLE.
- INITIALLY APPLY 2 OUNCES OF ANIONIC OR NEUTRALLY CHARGED PAM OVER WATTLE WHERE WATER WILL FLOW AND 1 OUNCE OF PAM ON EACH SIDE OF WATTLE. REAPPLY PAM AFTER EVERY RAINFALL EVENT THAT IS EQUAL TO OR EXCEEDS 0.50 IN.

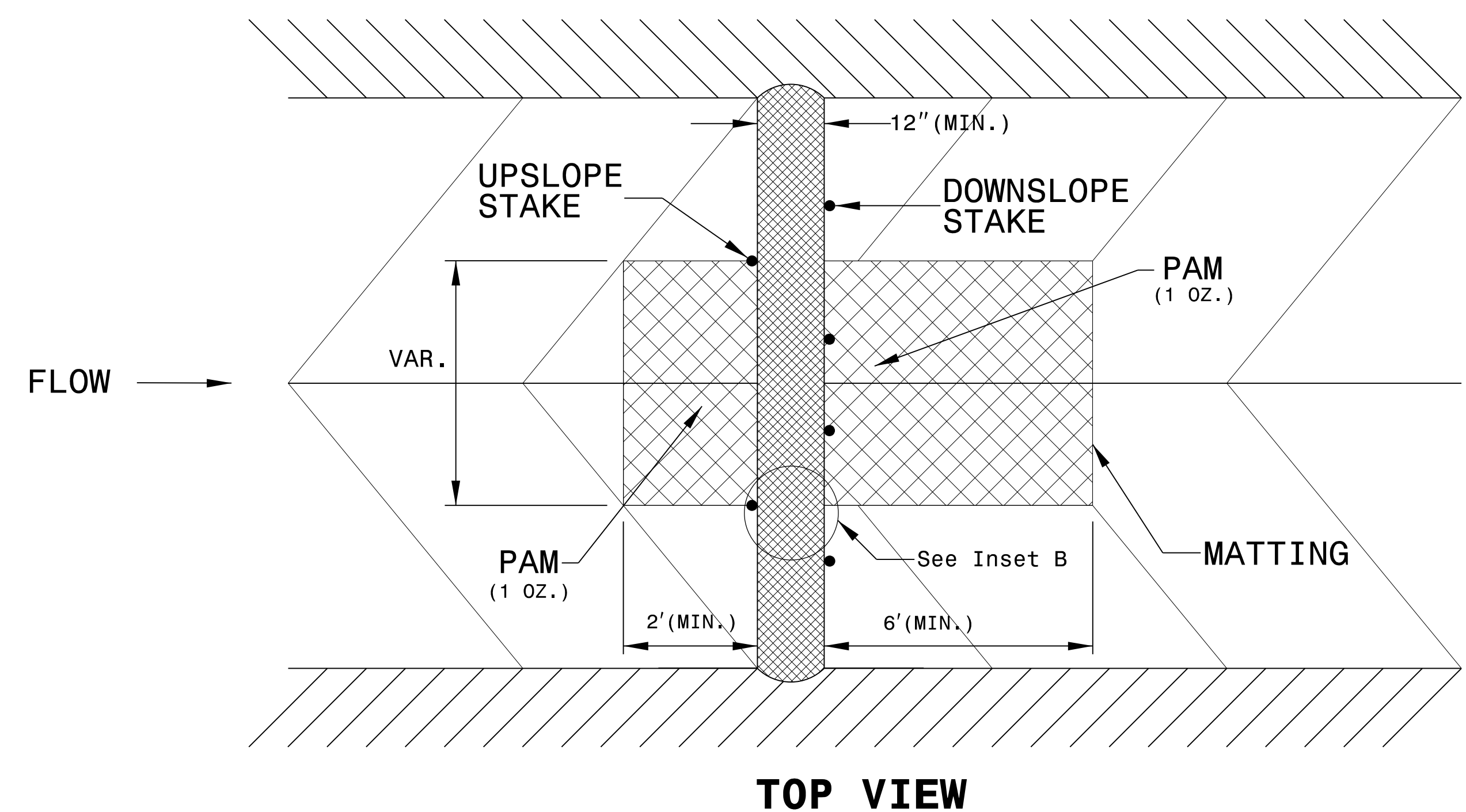
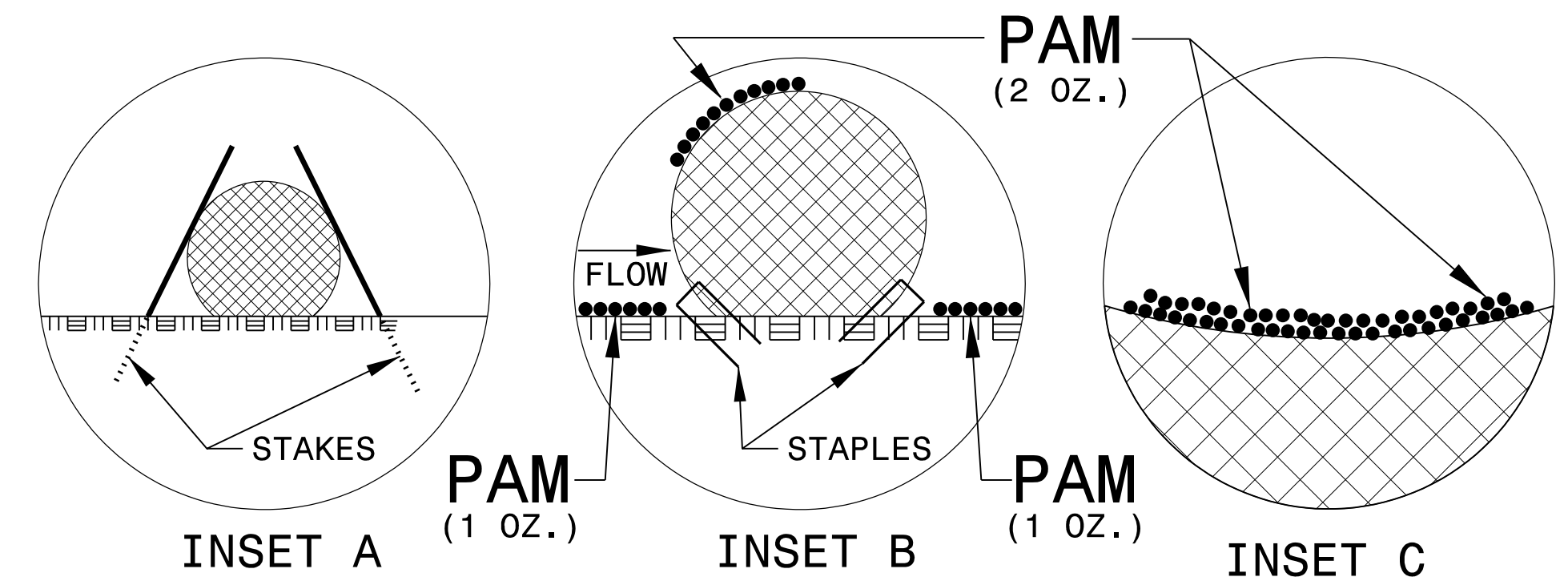

SILT FENCE COIR FIBER WATTLE BREAK DETAIL

PROJECT REFERENCE NO. W-5703Q	SHEET NO. EC-2A
RW SHEET NO.	
ROADWAY DESIGN ENGINEER	HYDRAULICS ENGINEER

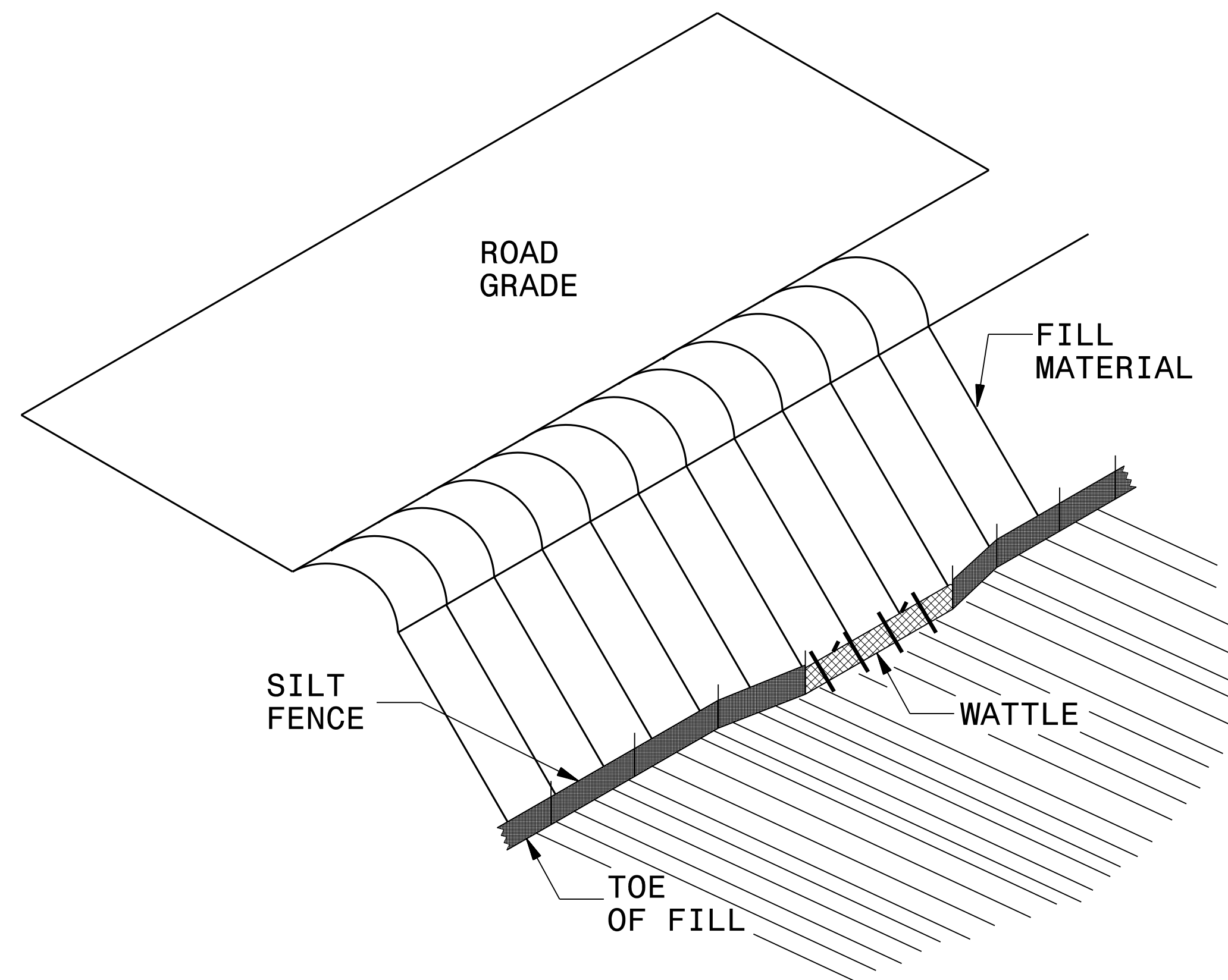

ISOMETRIC VIEW

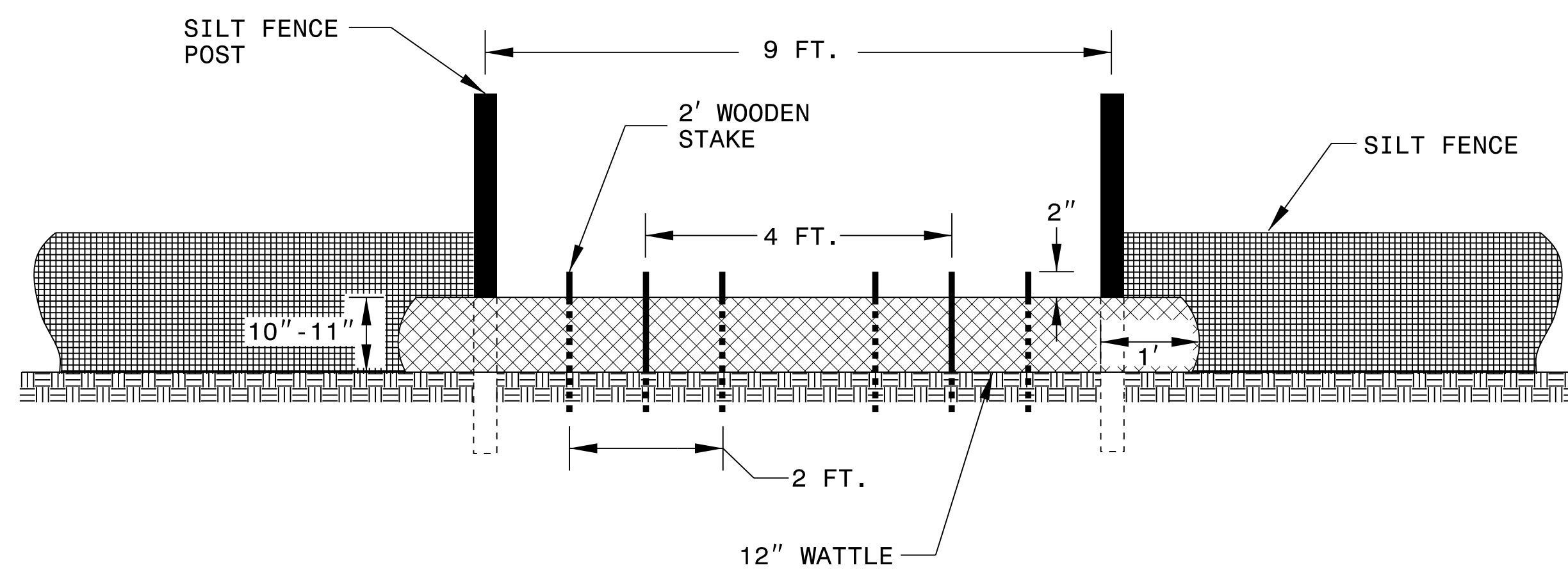

VIEW FROM SLOPE

NOTES:

- USE MINIMUM 12 IN. DIAMETER COIR FIBER (COCONUT FIBER) WATTLE AND LENGTH OF 10 FT.
- EXCAVATE A 1 TO 2 INCH TRENCH FOR WATTLE TO BE PLACED.
- DO NOT PLACE WATTLE ON TOE OF SLOPE.
- USE 2 FT. WOODEN STAKES WITH A 2 IN. BY 2 IN. NOMINAL CROSS SECTION.
- INSTALL A MINIMUM OF 2 UPSLOPE STAKES AND 4 DOWNSLOPE STAKES AT AN ANGLE TO WEDGE WATTLE TO GROUND.
- PROVIDE STAPLES MADE OF 0.125 IN. DIAMETER STEEL WIRE FORMED INTO A U SHAPE NOT LESS THAN 12" IN LENGTH.
- INSTALL STAPLES APPROXIMATELY EVERY 1 LINEAR FOOT ON BOTH SIDES OF WATTLE AND AT EACH END TO SECURE IT TO THE SOIL.
- WATTLE INSTALLATION CAN BE ON OUTSIDE OF THE SILT FENCE AS DIRECTED.
- INSTALL TEMPORARY SILT FENCE IN ACCORDANCE WITH SECTION 1605 OF THE STANDARD SPECIFICATIONS.

INSET A

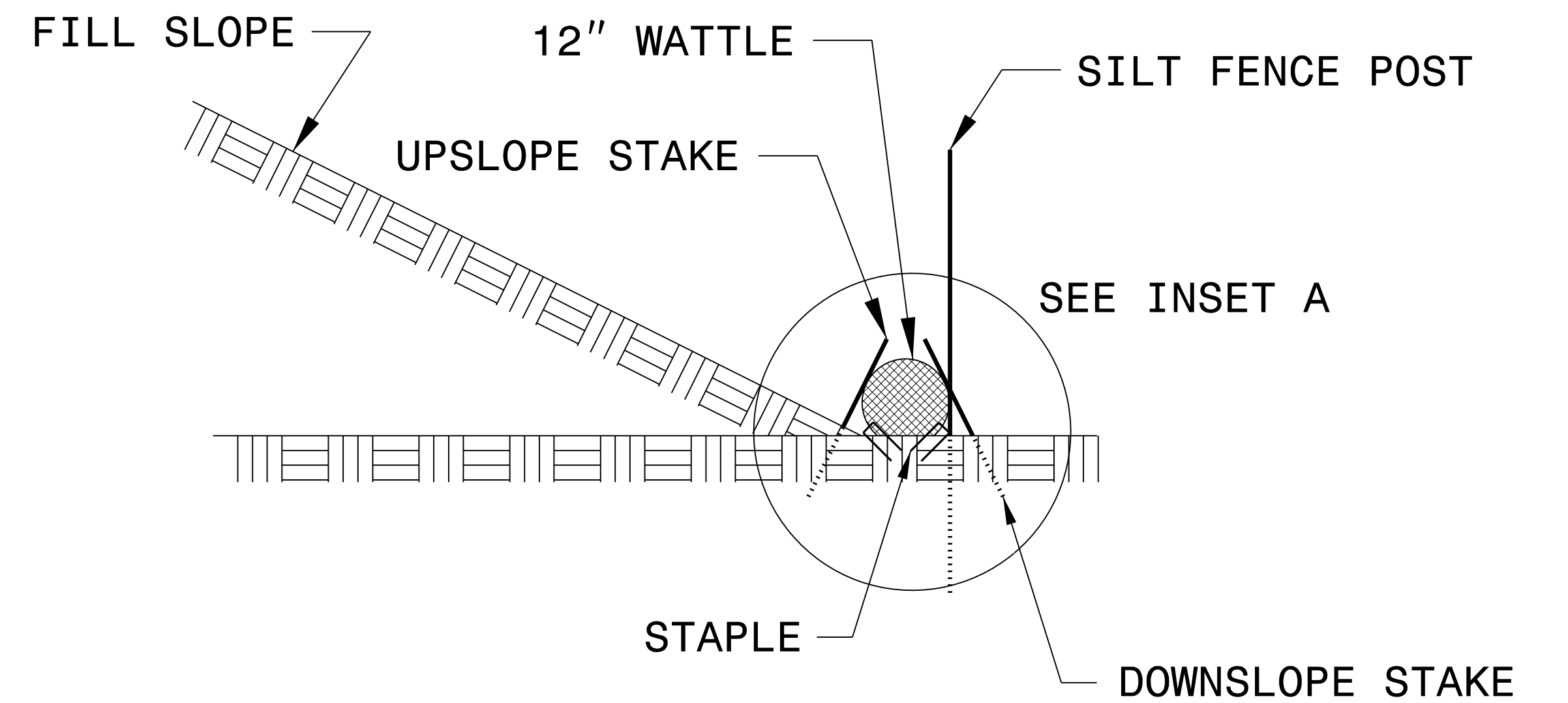
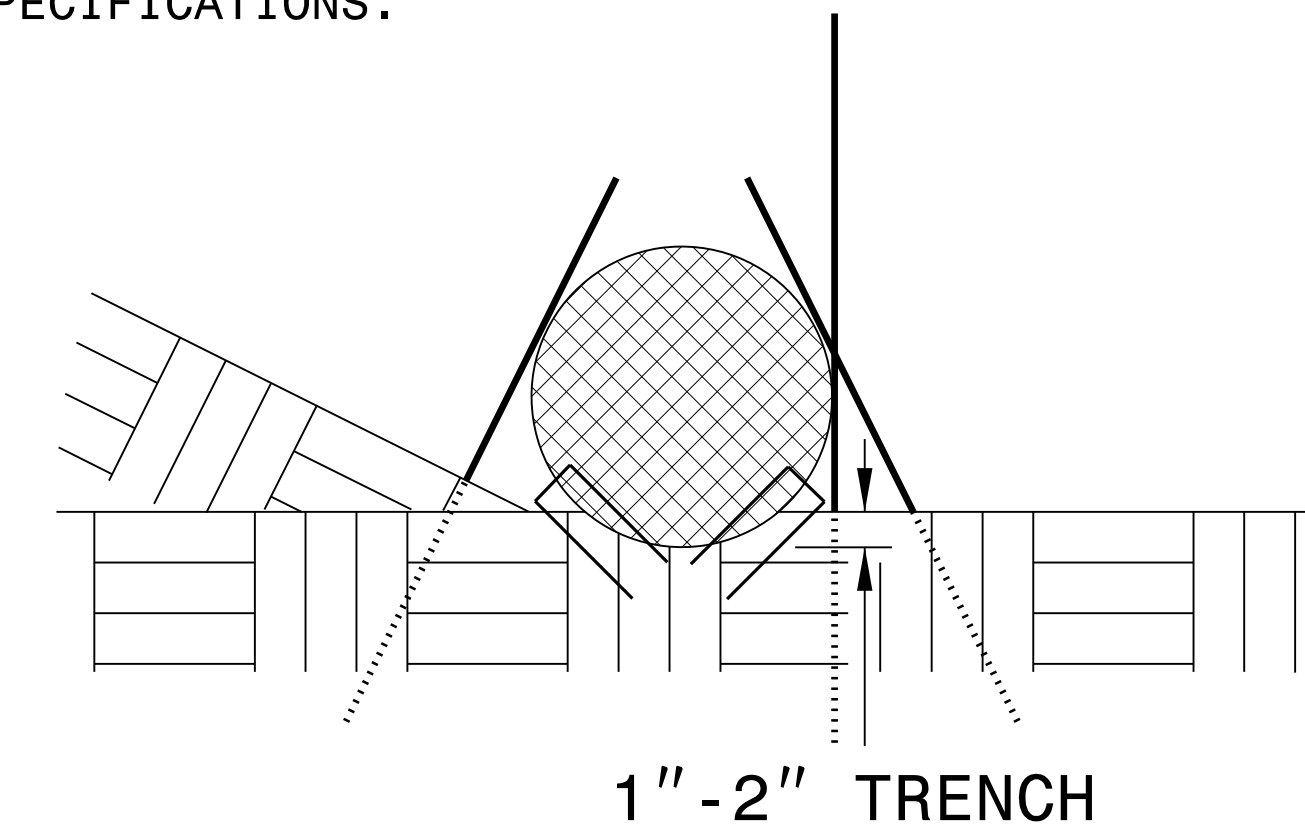

SIDE VIEW

DIVISION OF HIGHWAYS
STATE OF NORTH CAROLINA

PROJECT REFERENCE NO. <i>W-5703Q</i>	SHEET NO. <i>EC-3</i>
ROADWAY DESIGN ENGINEER	HYDRAULICS ENGINEER

SOIL STABILIZATION TIMEFRAMES

<i>SITE DESCRIPTION</i>	<i>STABILIZATION TIME</i>	<i>TIMEFRAME EXCEPTIONS</i>
PERIMETER DIKES, SWALES, DITCHES AND SLOPES	7 DAYS	NONE
HIGH QUALITY WATER (HQW) ZONES	7 DAYS	NONE
SLOPES STEEPER THAN 3:1	7 DAYS	IF SLOPES ARE 10' OR LESS IN LENGTH AND ARE NOT STEEPER THAN 2:1, 14 DAYS ARE ALLOWED.
SLOPES 3:1 OR FLATTER	14 DAYS	7 DAYS FOR SLOPES GREATER THAN 50' IN LENGTH.
ALL OTHER AREAS WITH SLOPES FLATTER THAN 4:1	14 DAYS	NONE, EXCEPT FOR PERIMETERS AND HQW ZONES.

PROJECT REFERENCE NO. W-57030	SHEET NO. EC-4/CONST.4
RW SHEET NO.	
ROADWAY DESIGN ENGINEER	HYDRAULICS ENGINEER
DOCUMENT NOT CONSIDERED FINAL UNLESS ALL SIGNATURES COMPLETED	
Prepared in the Office of:	 <small>NC FIRM LICENSE NO. P-0339 300 Executive Ct. Hillsborough, NC 27278 (919) 732-3883 (919) 732-6676 (FAX)</small>

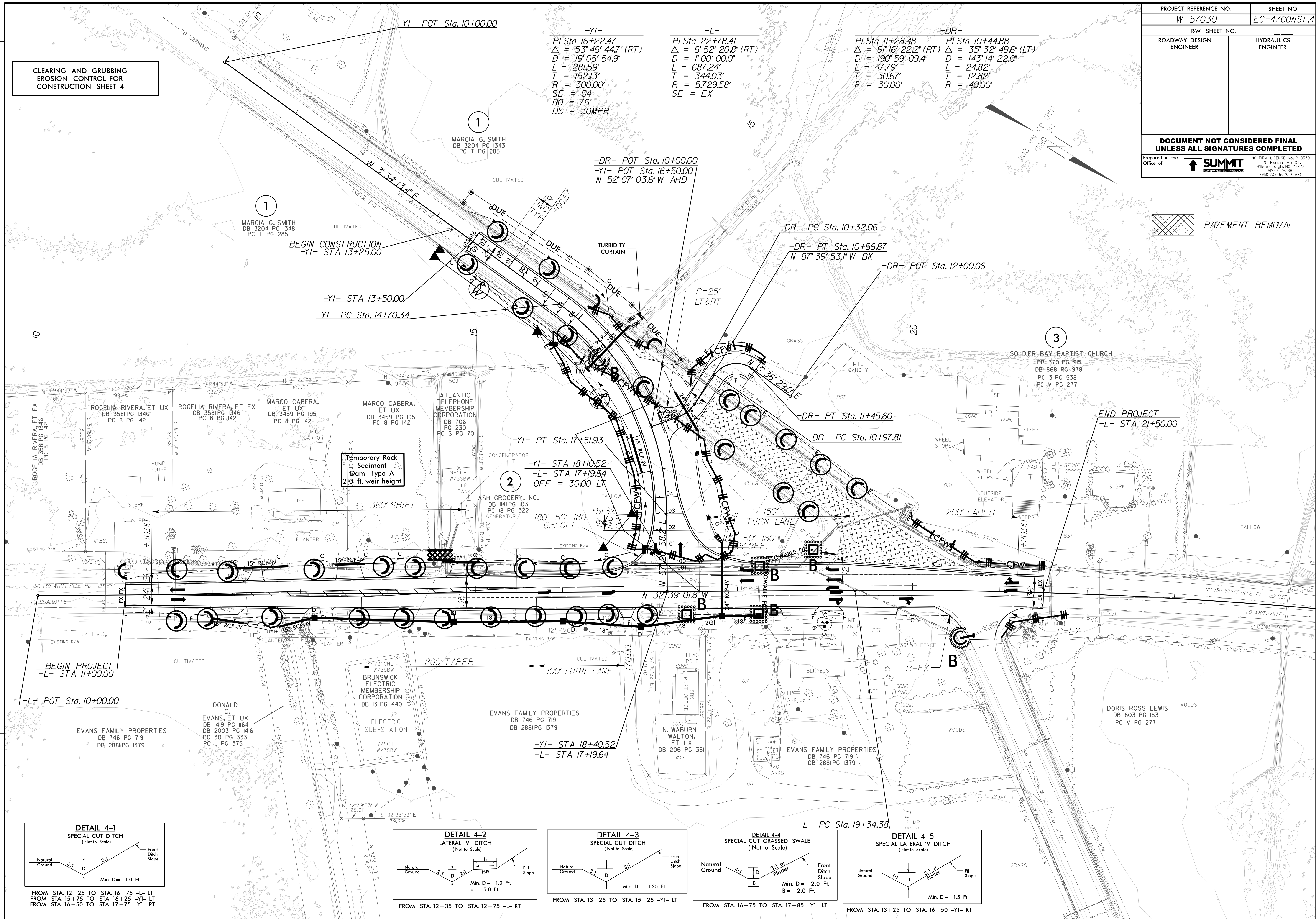

CLEARING AND GRUBBING
EROSION CONTROL FOR
CONSTRUCTION SHEET 4

Temporary Rock
Sediment
Dam Type A
2.0 ft. weir height

BEGIN PROJECT
-L- STA 11+00.00

-L- POT Sta. 10+00.00

BEGIN CONSTRUCTION
-YI- STA 13+25.00

-YI- STA 13+50.00

-YI- PC Sta. 14+70.34

-YI- PT Sta. 17+51.93

-YI- STA 18+10.52

-L- STA 17+19.64
OFF = 30.00 LT

-YI- STA 18+40.52

-L- STA 17+19.64

-DR- PC Sta. 10+32.06

-DR- PT Sta. 10+56.87
N 87° 39' 53.1" W BK

-DR- POT Sta. 12+00.06

-DR- PT Sta. 11+45.60

-DR- PC Sta. 10+97.81

-L- PC Sta. 19+34.38

END PROJECT
-L- STA 21+50.00

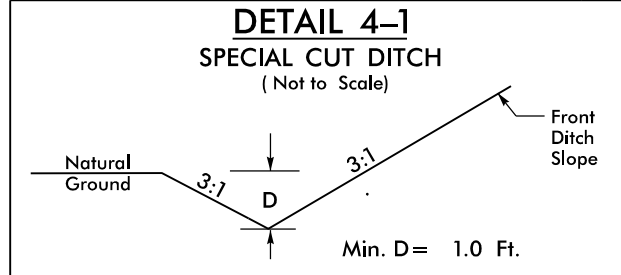

FROM STA. 12+25 TO STA. 16+75 -L- LT
FROM STA. 15+75 TO STA. 16+25 -YI- LT
FROM STA. 16+50 TO STA. 17+75 -YI- RT

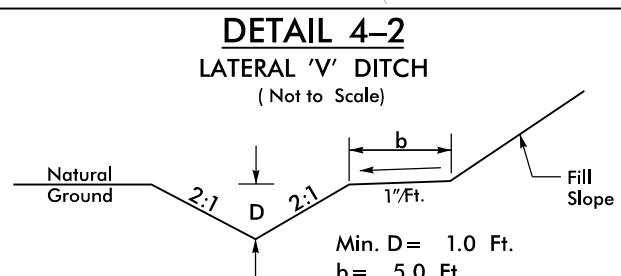

FROM STA. 12+35 TO STA. 12+75 -L- RT

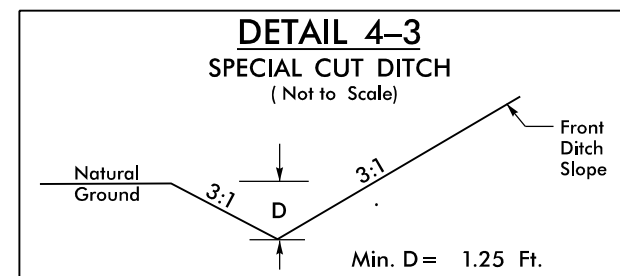

FROM STA. 13+25 TO STA. 15+25 -YI- LT

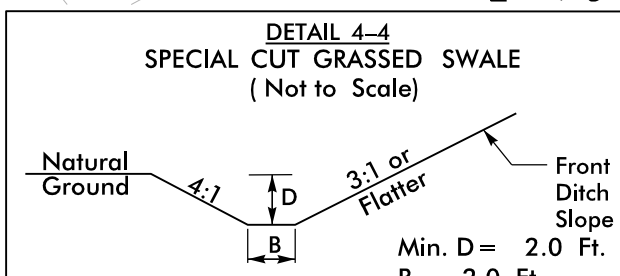

FROM STA. 16+75 TO STA. 17+85 -YI- LT

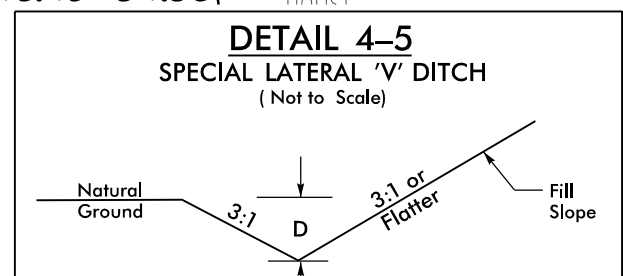

FROM STA. 13+25 TO STA. 16+50 -YI- RT

REVISIONS

-YI-
 PI Sta 16+22.47
 $\Delta = 53^\circ 46' 44.7''$ (RT)
 $D = 19^\circ 05' 54.9''$
 $L = 281.59'$
 $T = 152.13'$
 $R = 300.00'$
 $SE = 04$
 $RO = 76'$
 $DS = 30MPH$

-L-
 PI Sta 22+78.41
 $\Delta = 6^\circ 52' 20.8''$ (RT)
 $D = 1^\circ 00' 00.0''$
 $L = 687.24'$
 $T = 344.03'$
 $R = 5,729.58'$
 $SE = EX$

-DR-
 PI Sta 11+28.48
 $\Delta = 9^\circ 16' 22.2''$ (RT)
 $D = 190^\circ 59' 09.4''$
 $L = 47.79'$
 $T = 30.67'$
 $R = 30.00'$

PI Sta 10+44.88
 $\Delta = 35^\circ 32' 49.6''$ (LT)
 $D = 143^\circ 14' 22.0''$
 $L = 24.82'$
 $T = 12.82'$
 $R = 40.00'$

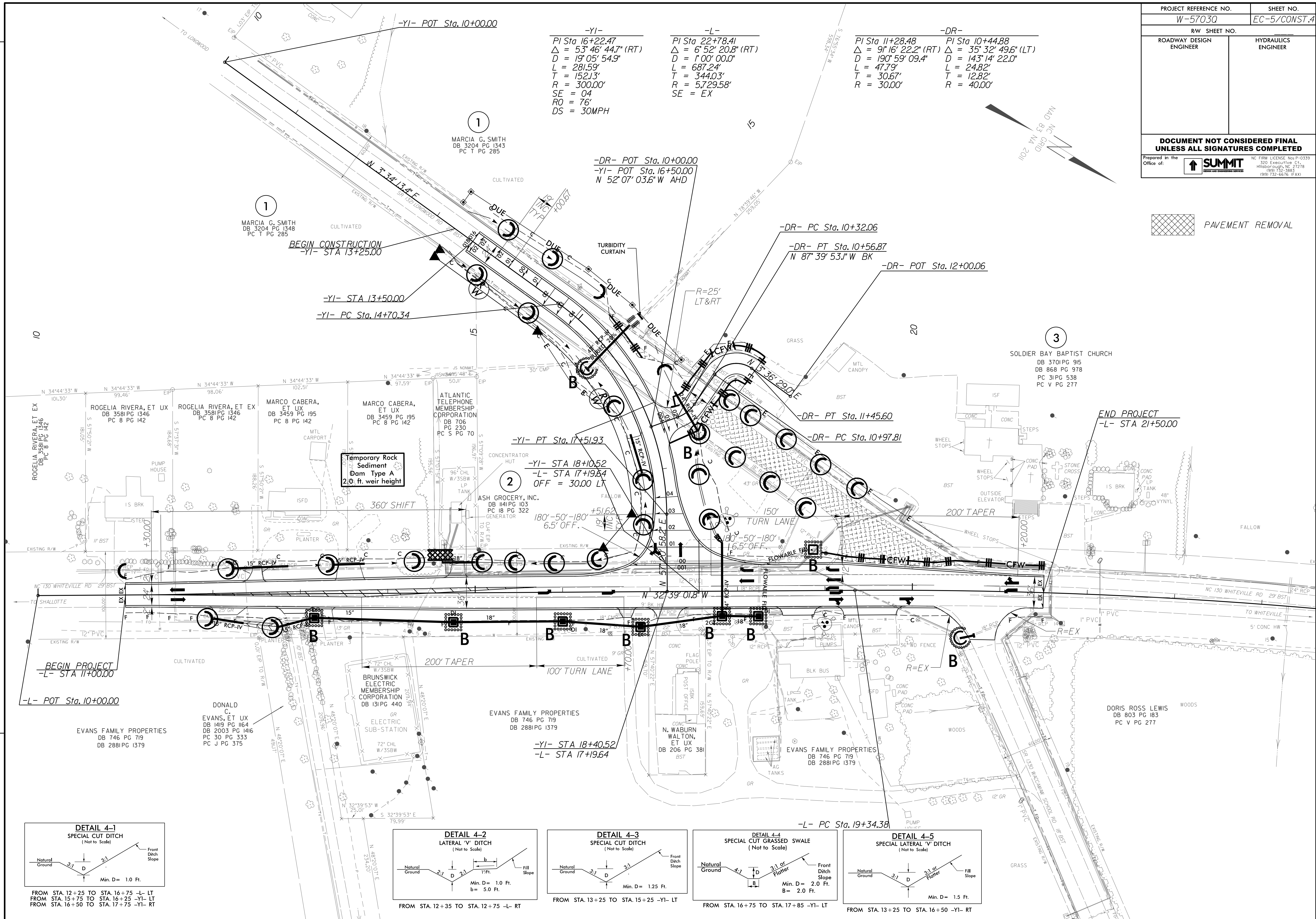

REVISIONS

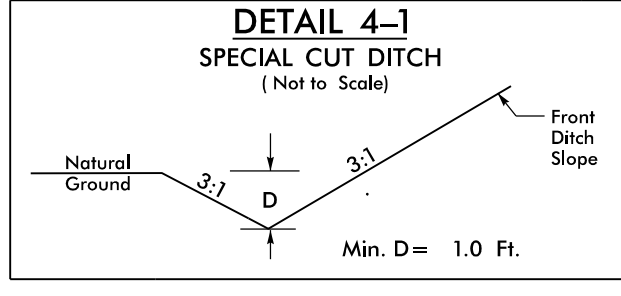

FROM STA. 12+25 TO STA. 16+75 -L- LT
 FROM STA. 15+75 TO STA. 16+25 -YI- LT
 FROM STA. 16+50 TO STA. 17+75 -YI- RT

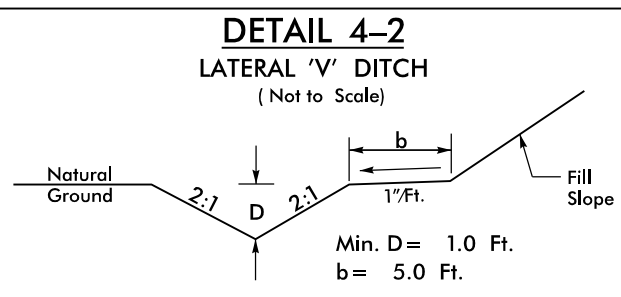

FROM STA. 12+35 TO STA. 12+75 -L- RT

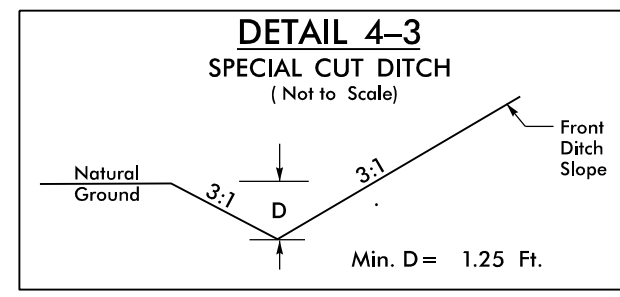

FROM STA. 13+25 TO STA. 15+25 -YI- LT

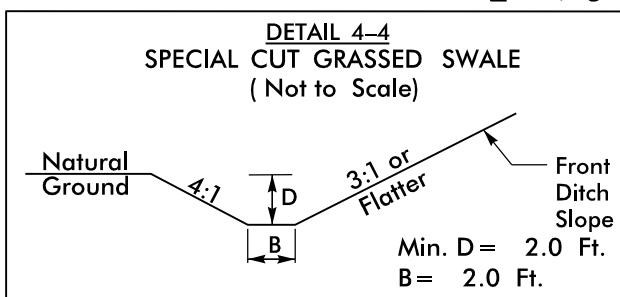

FROM STA. 16+75 TO STA. 17+85 -YI- LT

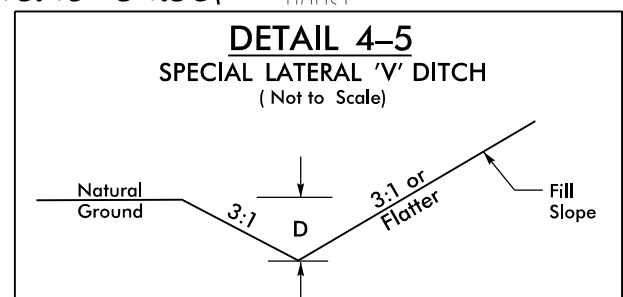

FROM STA. 13+25 TO STA. 16+50 -YI- RT

 PAVEMENT REMOVAL

09_08/19

T.I.P. NO.	SHEET NO.
W-5703Q	UC-1

STATE OF NORTH CAROLINA
DIVISION OF HIGHWAYS

**UTILITY CONSTRUCTION PLANS
BRUNSWICK COUNTY**

TIP PROJECT: W-5703Q

CONTRACT: DC00337

TO LONGWOOD
↖

**LOCATION: INTERSECTION OF NC 130 (WHITEVILLE RD.)
AT SR 1321 (LONGWOOD RD.)**
TYPE OF WORK: UTILITY CONSTRUCTION (WATER)

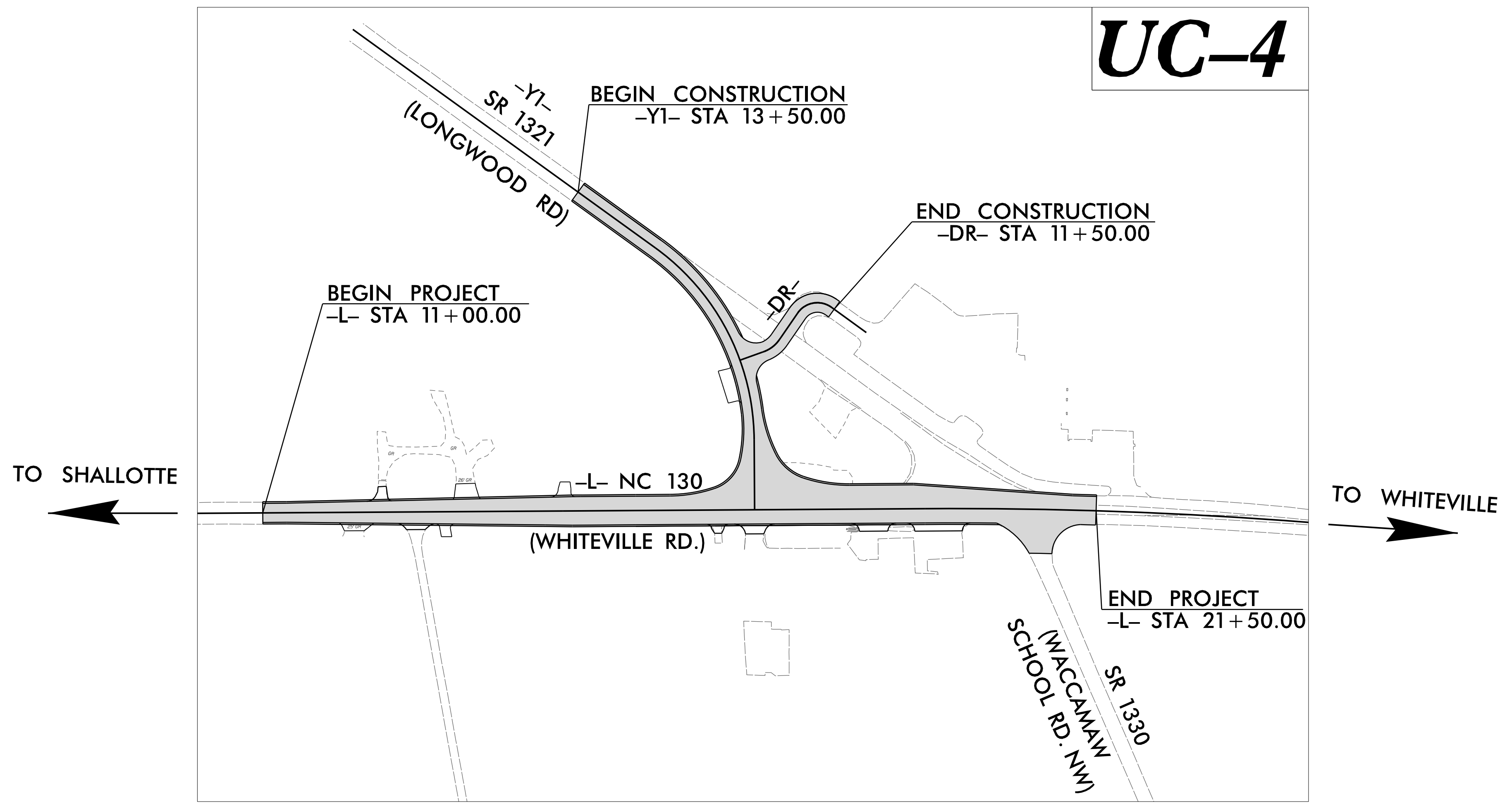

DOCUMENT NOT CONSIDERED FINAL
UNTIL ALL SIGNATURES ARE COMPLETED

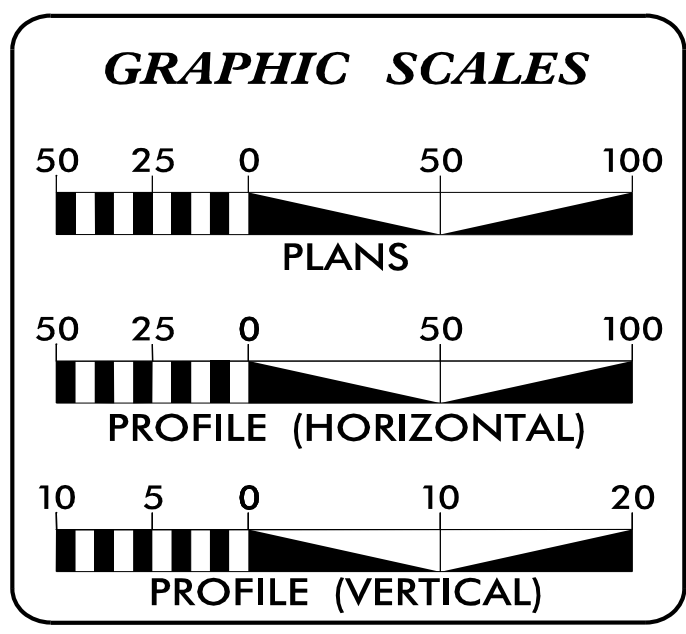

INDEX OF SHEETS

SHEET NO.:	DESCRIPTION:
UC-1	TITLE SHEET
UC-2	UTILITY SYMBOLOGY
UC-3	NOTES
UC-3A	DETAILS
UC-4	UTILITY CONSTRUCTION SHEETS

WATER AND SEWER OWNERS ON PROJECT
(A) BRUNSWICK COUNTY UTILITIES (WATER & SEWER)

PREPARED IN THE OFFICE OF

320 Executive Ct.
Hillsborough, NC 27278-8551
Voice: (919) 732-3883
Fax: (919) 732-6776
www.summitde.net

BRANDON W. JOHNSON, PE PROJECT ENGINEER
FAITH E. JAHNKE, PE PROJECT DESIGNER ENGINEER

SEAL

3/15/2022

DocuSigned by:
Brandon W. Johnson

**DIVISION OF HIGHWAYS
UTILITIES UNIT**
1555 MAIL SERVICES CENTER
RALEIGH, NC 27699-1555
PHONE (919) 707-6690
FAX (919) 250-4151

BO HEMPHILL, PE UTILITIES REGIONAL ENGINEER
LONNY SLEEPER DIVISION UTILITY ENGINEER
CHRIS SUTTON DIVISION UTILITY COORDINATOR
BEN MEYER, PE, CCM UTILITIES COORDINATOR

UTILITY CONSTRUCTION

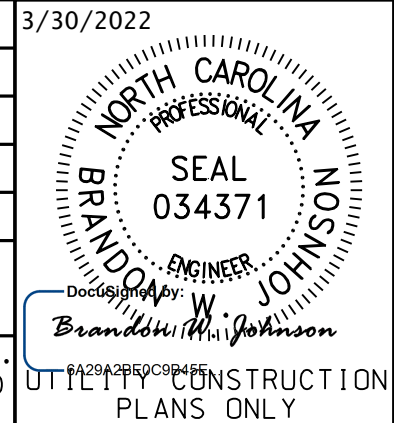
PROJECT REFERENCE NO.	SHEET NO.
W-5705Q	UC-3
DESIGNED BY: SWM	3/30/2022
DRAWN BY: SWM	
CHECKED BY: FEJ	
APPROVED BY: FEJ	
REVISED:	
NORTH CAROLINA DEPARTMENT OF TRANSPORTATION UTILITIES ENGINEERING SEC. PHONE: (919) 707-6690 FAX: (919) 250-4151	

GENERAL NOTES:

1. THE PROPOSED UTILITY CONSTRUCTION SHALL MEET THE APPLICABLE REQUIREMENTS OF THE NC DEPARTMENT OF TRANSPORTATION'S "STANDARD SPECIFICATIONS FOR ROADS AND STRUCTURES" DATED JANUARY 2018.
2. THE EXISTING UTILITIES BELONG TO BRUNSWICK COUNTY WATER & SEWER .
3. ALL WATER LINES TO BE INSTALLED WITHIN COMPLIANCE OF THE RULES AND REGULATIONS OF THE NORTH CAROLINA DEPARTMENT OF ENVIRONMENTAL QUALITY, DIVISION OF WATER RESOURCES, PUBLIC WATER SUPPLY SECTION. ALL SEWER LINES TO BE INSTALLED WITHIN COMPLIANCE OF THE RULES AND REGULATIONS OF THE NORTH CAROLINA DEPARTMENT OF ENVIRONMENT QUALITY, DIVISION OF WATER RESOURCES, WATER QUALITY SECTION. PERFORM ALL WORK IN ACCORDANCE WITH THE APPLICABLE PLUMBING CODES.
4. THE UTILITY OWNER OWNS THE EXISTING UTILITY FACILITIES AND WILL OWN THE NEW UTILITY FACILITIES AFTER ACCEPTANCE BY THE DEPARTMENT. THE DEPARTMENT OWNS THE CONSTRUCTION CONTRACT AND HAS ADMINISTRATIVE AUTHORITY. COMMUNICATIONS AND DECISIONS BETWEEN THE CONTRACTOR AND UTILITY OWNER ARE NOT BINDING UPON THE DEPARTMENT OR THIS CONTRACT UNLESS AUTHORIZED BY THE ENGINEER. AGREEMENTS BETWEEN THE UTILITY OWNER AND CONTRACTOR FOR THE WORK THAT IS NOT PART OF THIS CONTRACT OR IS SECONDARY TO THIS CONTRACT ARE ALLOWED, BUT ARE NOT BINDING UPON THE DEPARTMENT.
5. PROVIDE ACCESS FOR THE DEPARTMENT PERSONNEL AND THE OWNER'S REPRESENTATIVES TO ALL PHASES OF CONSTRUCTION. NOTIFY DEPARTMENT PERSONNEL AND THE UTILITY OWNER TWO WEEKS PRIOR TO COMMENCEMENT OF ANY WORK AND ONE WEEK PRIOR TO SERVICE INTERRUPTION. KEEP UTILITY OWNERS' REPRESENTATIVES INFORMED OF WORK PROGRESS AND PROVIDE OPPORTUNITY FOR INSPECTION OF CONSTRUCTION AND TESTING.

6. THE PLANS DEPICT THE BEST AVAILABLE INFORMATION FOR THE LOCATION, SIZE, AND TYPE OF MATERIAL FOR ALL EXISTING UTILITIES. MAKE INVESTIGATIONS FOR DETERMINING THE EXACT LOCATION, SIZE, AND TYPE MATERIAL OF THE EXISTING FACILITIES AS NECESSARY FOR THE CONSTRUCTION OF THE PROPOSED UTILITIES AND FOR AVOIDING DAMAGE TO EXISTING FACILITIES. REPAIR ANY DAMAGE INCURRED TO EXISTING FACILITIES TO THE ORIGINAL OR BETTER CONDITION AT NO ADDITIONAL COST TO THE DEPARTMENT.
7. MAKE FINAL CONNECTIONS OF THE NEW WORK TO THE EXISTING SYSTEM WHERE INDICATED ON THE PLANS, AS REQUIRED TO FIT THE ACTUAL CONDITIONS, OR AS DIRECTED.
8. MAKE CONNECTIONS BETWEEN EXISTING AND PROPOSED UTILITIES AT TIMES MOST CONVENIENT TO THE PUBLIC, WITHOUT ENDANGERING THE UTILITY SERVICE, AND IN ACCORDANCE WITH THE UTILITY OWNER'S REQUIREMENTS. MAKE CONNECTIONS ON WEEKENDS, AT NIGHT, AND ON HOLIDAYS IF NECESSARY.
9. ALL UTILITY MATERIALS SHALL BE APPROVED PRIOR TO DELIVERY TO THE PROJECT. SEE 1500-7, " SUBMITTALS AND RECORDS" IN SECTION 1500 OF THE STANDARD SPECIFICATIONS.

PROJECT SPECIFIC NOTES:

1. PROPOSED WATER LINE FROM -Y1- LINE STATION 15+30+/- TO -Y1- LINE STATION 15+56+/- SHALL BE P.V.C.(POLYVINYL CHLORIDE) PIPE. PROPOSED WATER LINE FROM -L- LINE STATION 17+72+/- TO -L- LINE STATION 17+93+/- SHALL BE P.V.C.(POLYVINYL CHLORIDE) PIPE.
2. CONTRACTOR'S ATTENTION IS DIRECTED TO SECTIONS 102, 107, AND 1550 OF THE STANDARD SPECIFICATIONS CONCERNING TRENCHLESS INSTALLATION. IT IS CONTRACTOR'S RESPONSIBILITY TO HAVE BORE DESIGNED AND SEALED BY A LICENSED NORTH CAROLINA PROFESSIONAL ENGINEER. NO DAMAGE IS ALLOWED TO RIVER, WETLANDS, OR BUFFER ZONES.
3. THE CONTRACTOR SHALL COORDINATE WITH THE UTILITY OWNER CONCERNING THE TIMING AND SCHEDULE OF REQUIRED SHUTDOWNS TO ANY EXISTING UTILITIES. PROVIDE A TWO-WEEK NOTIFICATION PRIOR TO STARTING WATERLINE WORK AND A 72-HOUR NOTICE FOR ANY SHUTDOWNS AND CUTOVERS. THE CONTACT FOR BRUNSWICK COUNTY PUBLIC UTILITIES IS BRENT LOCKAMY, DEPUTY DIRECTOR OF DESIGN AND CONSTRUCTION AND HE CAN BE REACHED BY PHONE AT 910-253-2460.

LIST OF STANDARD DRAWINGS

- 1515.01 WATER METER
- 1515.02 FIRE HYDRANT

UTILITY CONSTRUCTION

**DOCUMENT NOT CONSIDERED FINAL
UNLESS ALL SIGNATURES COMPLETED**

PROJECT TYPICAL DETAILS

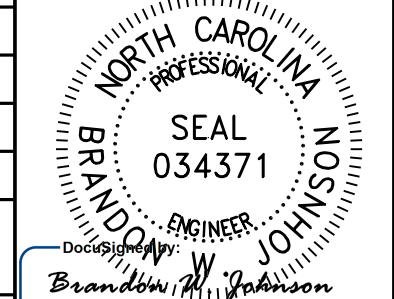
PROJECT REFERENCE NO.	SHEET NO.
	UC-3A
DESIGNED BY:	3/30/2022
DRAWN BY:	
CHECKED BY:	
APPROVED BY:	
REVISED:	
NORTH CAROLINA DEPARTMENT OF TRANSPORTATION	
UTILITIES ENGINEERING SEC. PHONE: (919) 707-6690 FAX: (919) 250-4151	
	
UTILITY CONSTRUCTION PLANS ONLY	

UTILITY CONSTRUCTION

DOCUMENT NOT CONSIDERED FINAL
UNLESS ALL SIGNATURES COMPLETED

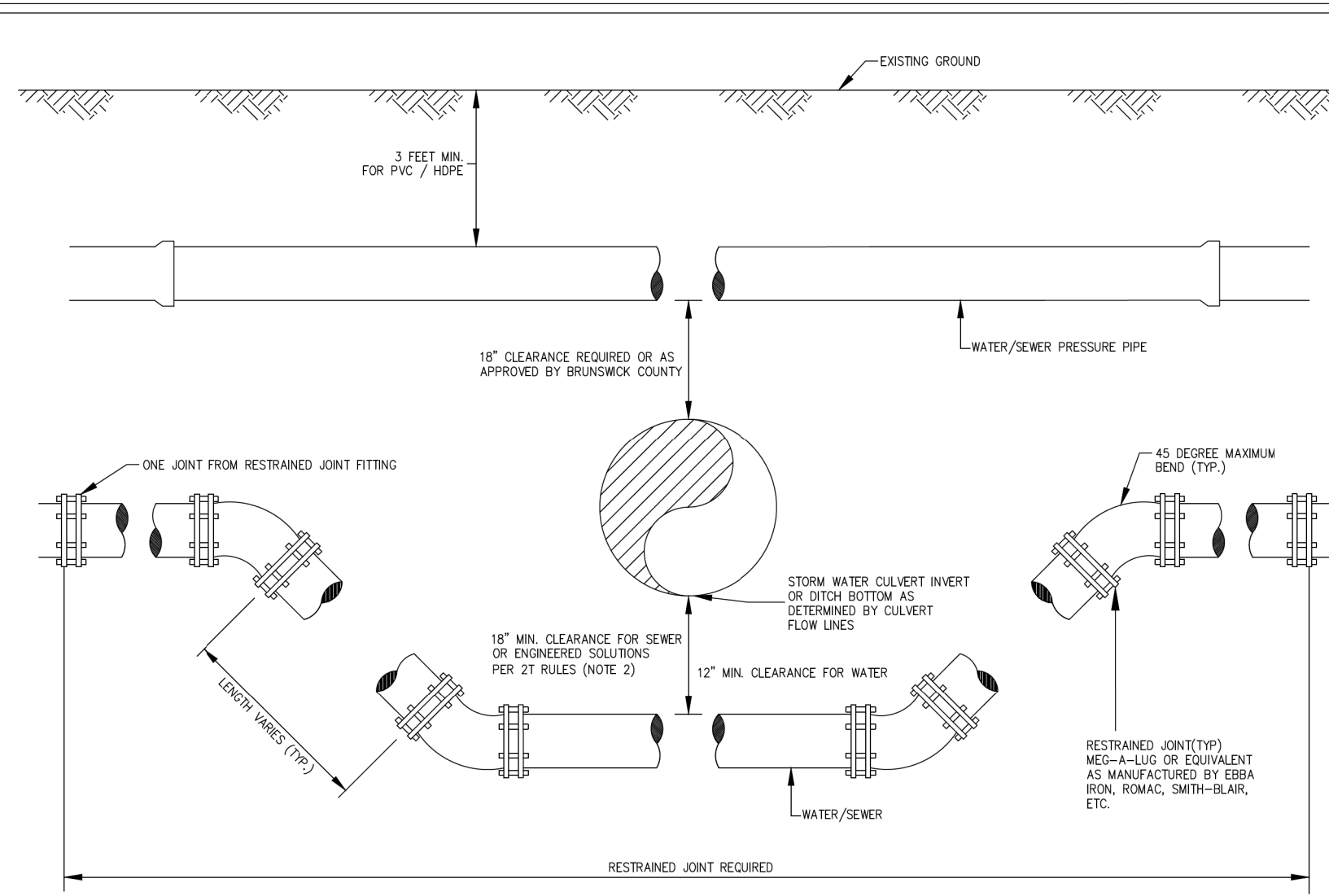

- NOTES:
- USE STAINLESS STEEL THREADED RODS, MEGA-LUG OR APPROVED EQUAL FOR JOINT RESTRAINT.
 - SEWER REQUIRES DR-18 C900 UNLESS OTHERWISE APPROVED BY BRUNSWICK COUNTY.
 - WATER MAY BE DIP OR DR-18 C900 PIPE.

DITCH AND/OR STORM DRAIN CROSSING
OFFSETS BETWEEN WATER/SEWER
PRESSURE MAIN AND STORM DRAIN
DETAIL WS-20

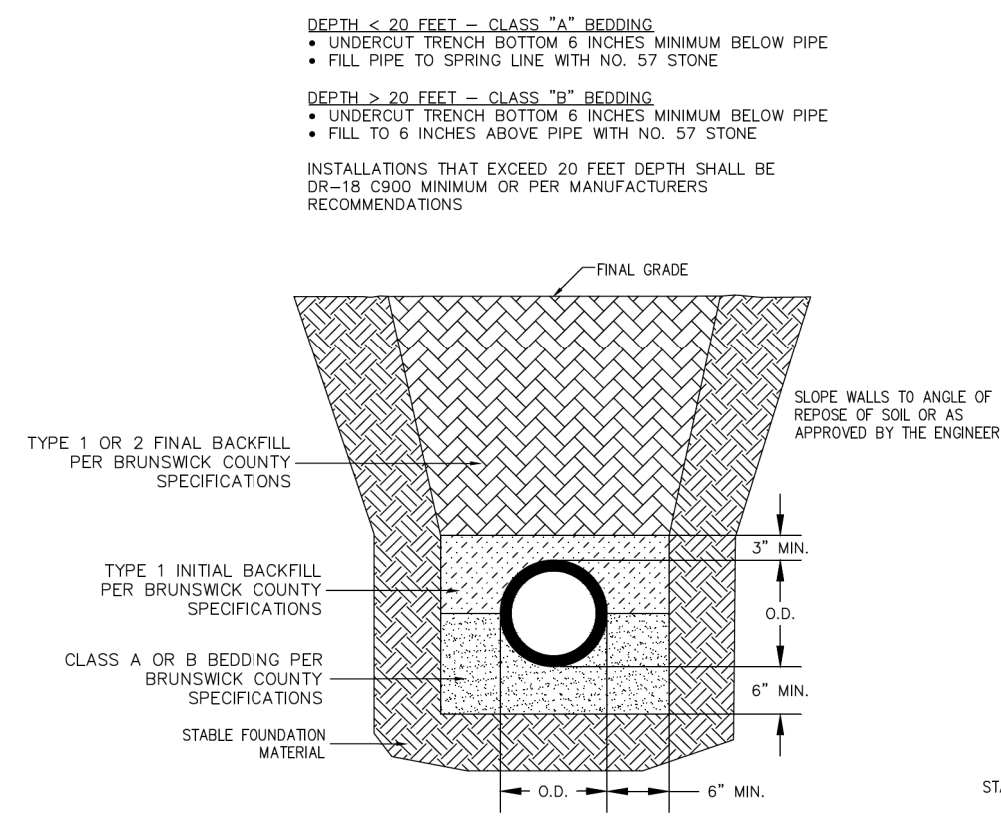

- NOTES:
- REFER TO THE BRUNSWICK COUNTY TECHNICAL SPECIFICATIONS FOR BACKFILL AND TRENCHING REQUIREMENTS
 - PIPE SIZE AS INDICATED ON PLANS

GRAVITY SEWER
PIPE TRENCH/BEDDING DETAIL
DETAIL WS-22

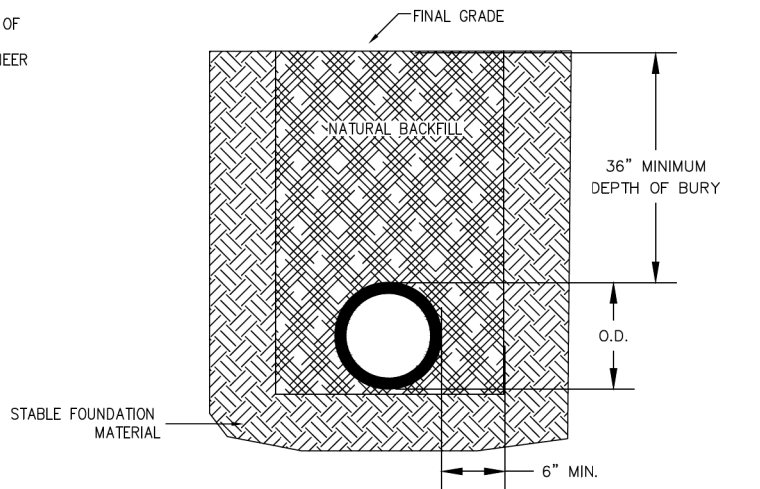

WATERMAIN AND/OR SEWER FORCEMAIN (PRESSURE PIPE)
PIPE TRENCH/BEDDING DETAIL
DETAIL WS-22A

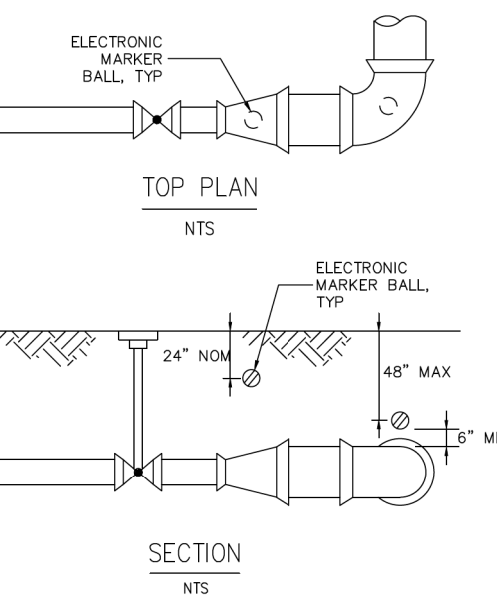

- NOTES:
- ELECTRONIC MARKER BALL MATERIALS SHALL BE AS FOLLOWS:
 - WATER - 4-INCH DIAMETER, BLUE
 - SEWER - 4-INCH DIAMETER, GREEN
 - RECLAIMED WATER - 4-INCH DIAMETER, PURPLE
 - PLACEMENT SHALL CONFORM TO DETAILS ABOVE FOR FURTHER GUIDANCE. REFER TO BRUNSWICK COUNTY TECHNICAL SPECIFICATIONS SECTION TITLED "ELECTRONIC MARKER BALLS FOR WATER AND SEWER FORCE MAINS".

ELECTRONIC MARKER
BALL PLACEMENT DETAIL
DETAIL WS-23

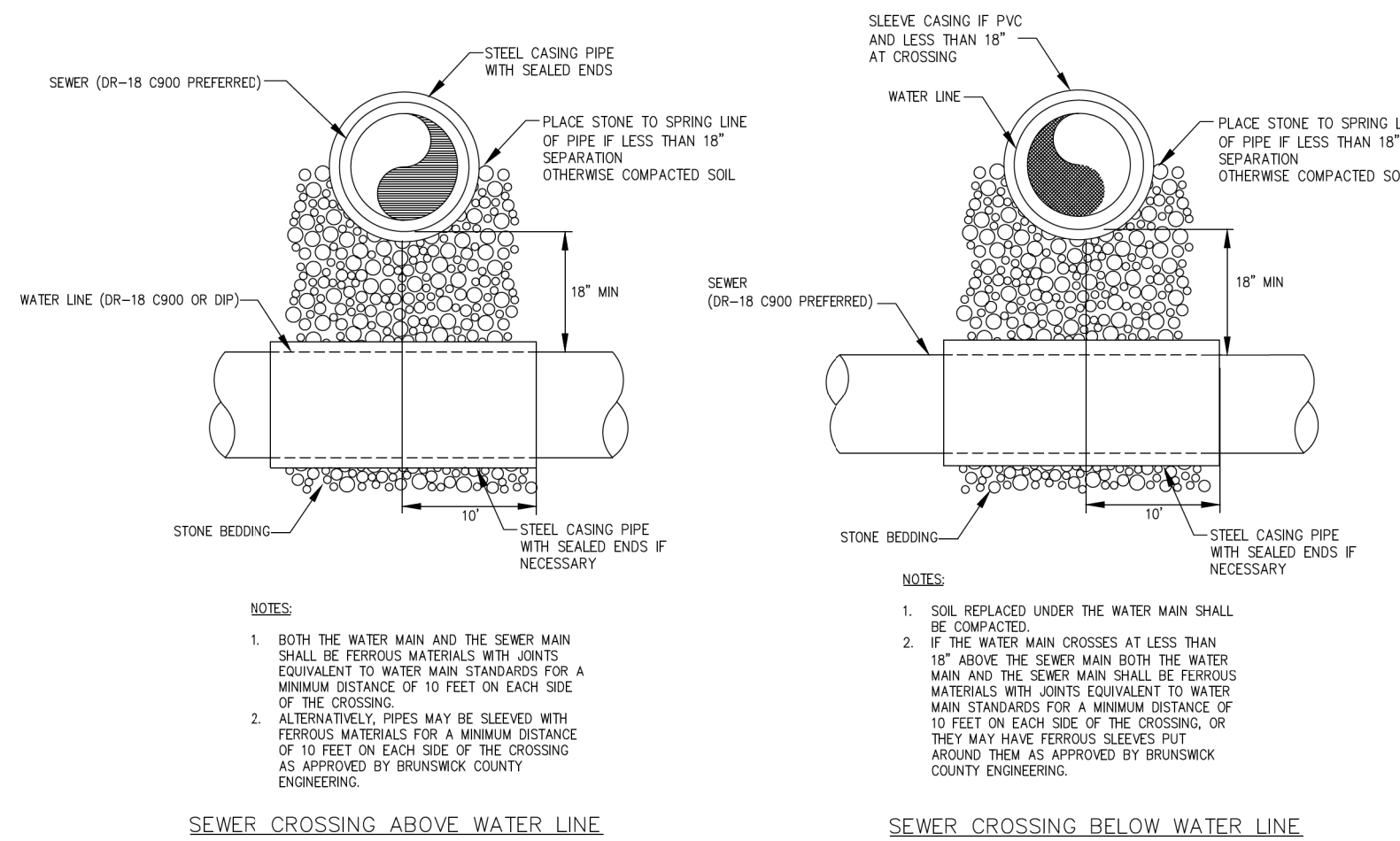

- NOTES:
- BOTH THE WATER MAIN AND THE SEWER MAIN SHALL BE FERROUS MATERIALS WITH JOINTS EQUIVALENT TO WATER MAIN STANDARDS FOR A MINIMUM DISTANCE OF 10 FEET ON EACH SIDE OF THE CROSSING.
 - ALTERNATELY, PIPES MAY BE SLEEVED WITH FERROUS MATERIALS FOR A MINIMUM DISTANCE OF 10 FEET ON EACH SIDE OF THE CROSSING OR THEY MAY HAVE FERROUS SLEEVES PUT AROUND THEM AS APPROVED BY BRUNSWICK COUNTY ENGINEERING.

SEWER CROSSING ABOVE WATER LINE
SEWER OFFSETS ABOVE
AND BELOW WATER MAINS
DETAIL WS-21

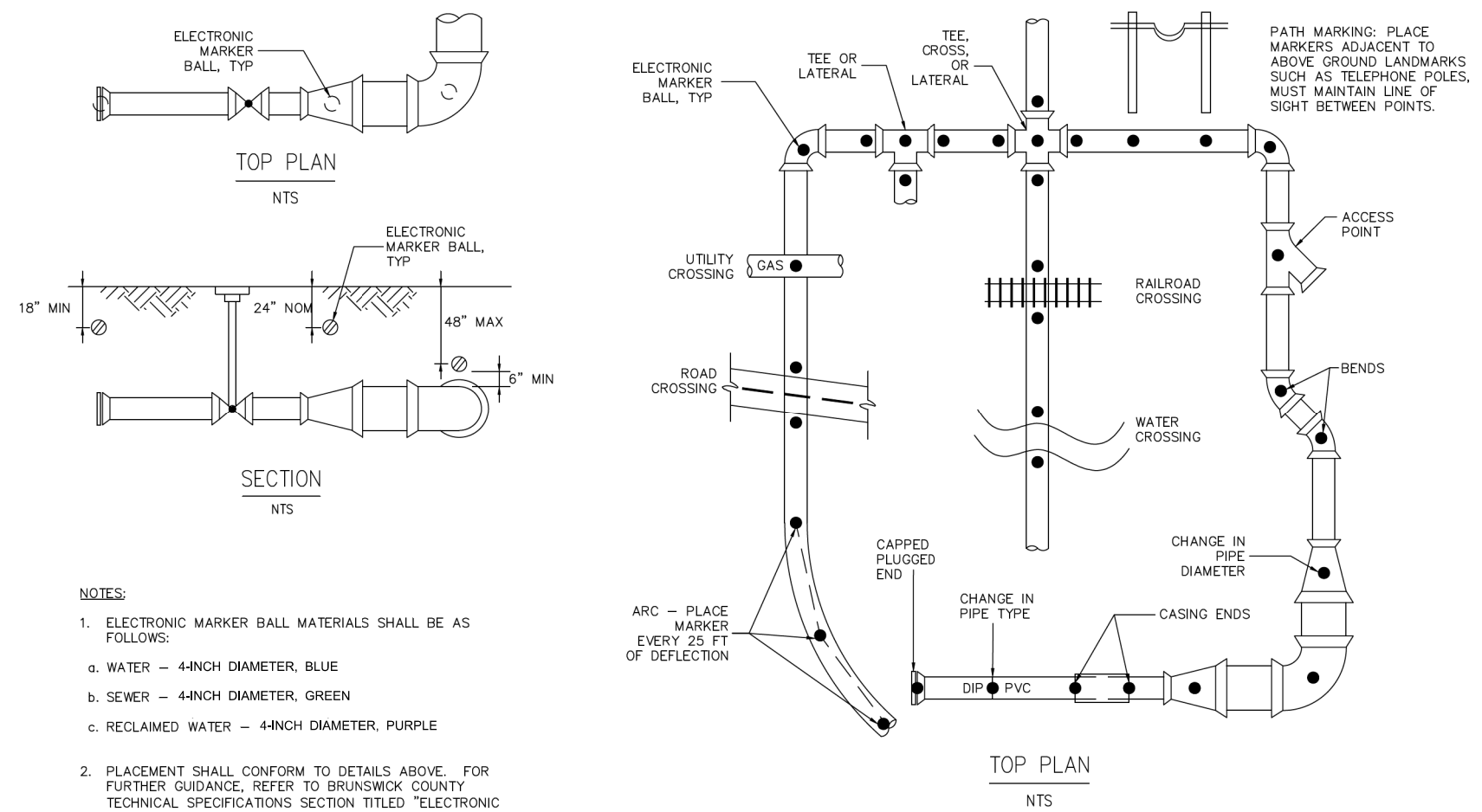

Revisions

1.1	DATED 7/12/2013
1.2	DATED 1/16/2014
1.3	DATED 1/20/2019
1.4	DATED 7/16/2019
1.5	DATED 2/12/2021
Mod WS-20 & WS-21	

COUNTY OF BRUNSWICK

GENERAL WATER & SEWER DETAILS
FOR
BRUNSWICK COUNTY
NORTH CAROLINA

Date: 05/11/22
Scale: NTS
Drawn By: JDM
Checked By: WJP

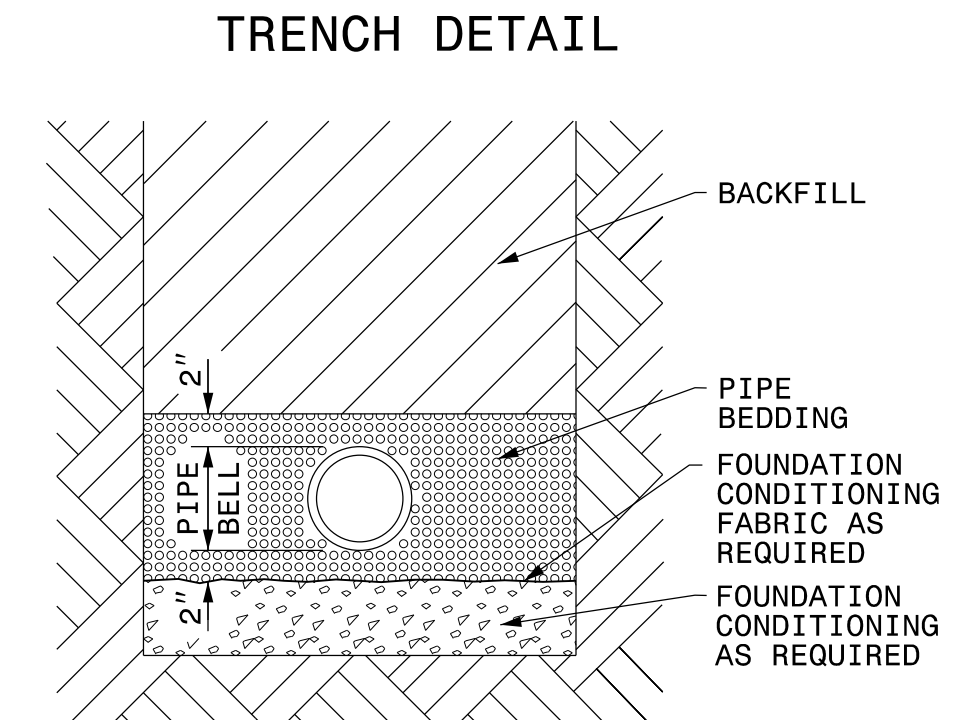

PLACE FOUNDATION CONDITIONING MATERIAL BELOW BEDDING IF REQUIRED, AS DIRECTED BY ENGINEER. PIPE BEDDED IN SELECT MATERIAL, CLASS II (TYPE 1) OR CLASS III. TRENCH BACKFILLED IN LOOSE 6" LAYERS COMPACTED TO TOP OF TRENCH USING LOCAL EXCAVATED MATERIAL IF APPROVED BY THE ENGINEER, OR SELECT MATERIAL. ALL MATERIAL SHALL BE FREE OF ROCKS, FOREIGN MATERIAL AND FROZEN EARTH. COMPACTION SHALL BE TO APPROXIMATELY 95% DENSITY IN ACCORDANCE WITH AASHTO T-99 AS MODIFIED BY THE DEPARTMENT OF TRANSPORTATION.

5/14/19

PROJECT REFERENCE NO.	SHEET NO.
W-5703Q	UC-4
DESIGNED BY: SWM	3/9/2022
DRAWN BY: SWM	
CHECKED BY: FEJ	
APPROVED BY: FEJ	
REVISED:	
<small>NC FIRM LICENSE No. P-0339 225 EXHIBIT "C" MEMBER OF THE 1999 132-6616 (F&M)</small>	
DOCUMENT NOT CONSIDERED FINAL UNLESS ALL SIGNATURES COMPLETED	

UTILITY CONSTRUCTION



NOTE:
THE ESTIMATED QUANTITY OF DUCTILE IRON WATER PIPE FITTINGS ON THIS PLAN SHEET IS 1720 POUNDS. THE ACTUAL QUANTITY AND TYPE OF FITTINGS WILL VARY BASED ON FIELD CONDITIONS.

RELOCATE FIRE HYDRANT (1)
-YI- 16+22 +/- LT
ADJUST WATER VALVE (1)
-YI- 16+22 +/- LT

PROP. 2- 45 DEGREE BENDS (VERT.)
(SEE DETAIL ON UC-3A)

PROP. 12" C-900 PVC WATER LINE
36 LF

PROP. 2- 45 DEGREE BENDS (VERT.)
(SEE DETAIL ON UC-3A)

RELOCATE WATER METER (1)
-L- 12+37 +/- LT

PROP. 12" C-900 PVC WATER LINE
25 LF

PROP. 4- 45 DEGREE BENDS (VERT.)
(SEE DETAIL ON UC-3A)

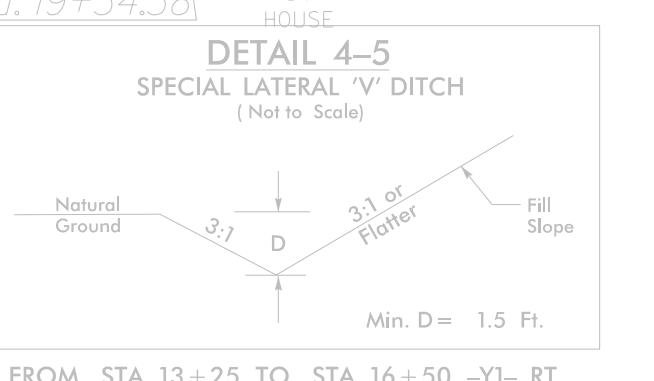
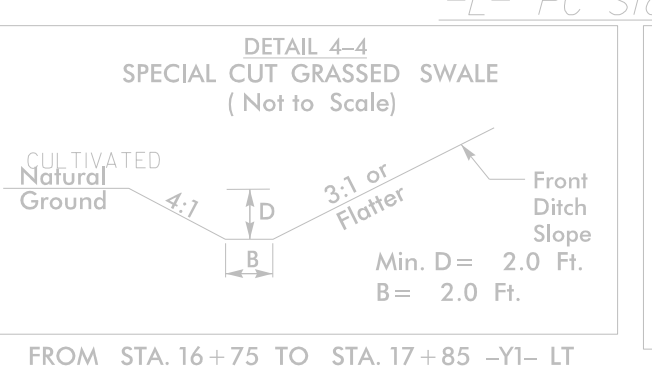
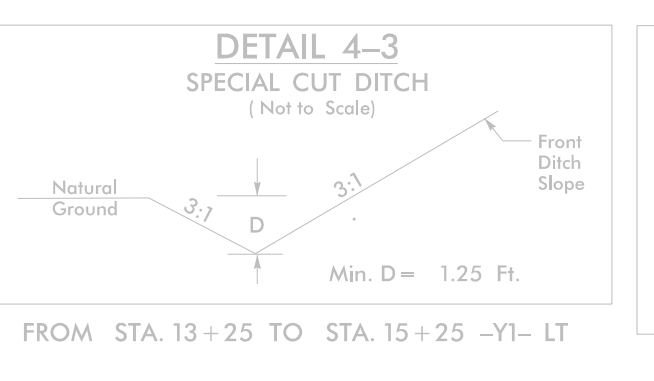
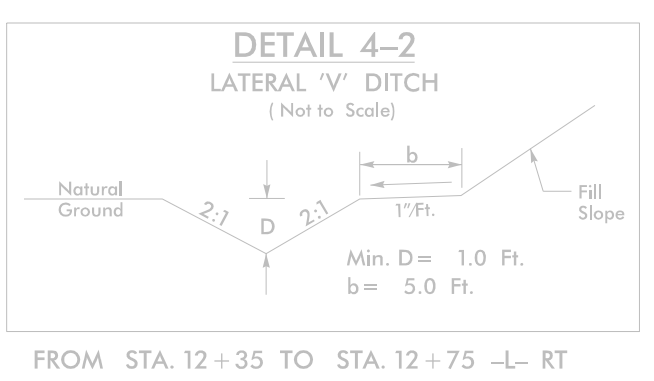
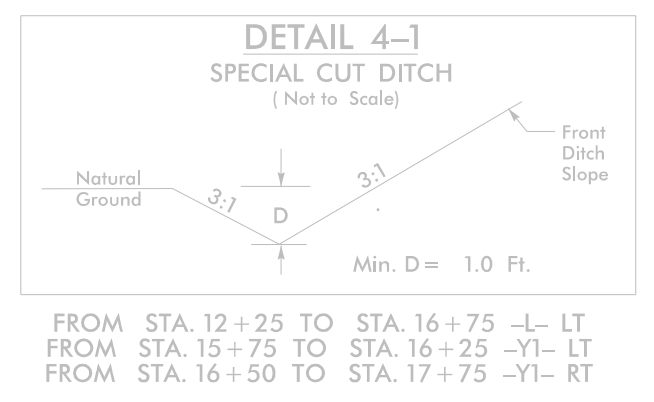

03-MAR-2022 10:33 UC-4_psh.dgn

09/28/19

See Sheet 1A For Index of Sheets
 See Sheet 1B For Conventional Symbols
 See Sheet 1C-1 For Survey Control Sheet

STATE OF NORTH CAROLINA
 DIVISION OF HIGHWAYS

STATE	STATE PROJECT REFERENCE NO.	SHEET NO.	TOTAL SHEETS
N.C.	W-5703Q	UO-1	
STATE PROJ. NO.	F.A. PROJ. NO.	DESCRIPTION	
44849.1.1	-	P.E.	
44849.2.17	-	ROW	
44849.3.1	-	CONSTRUCTION	

TIP PROJECT: W-5703Q

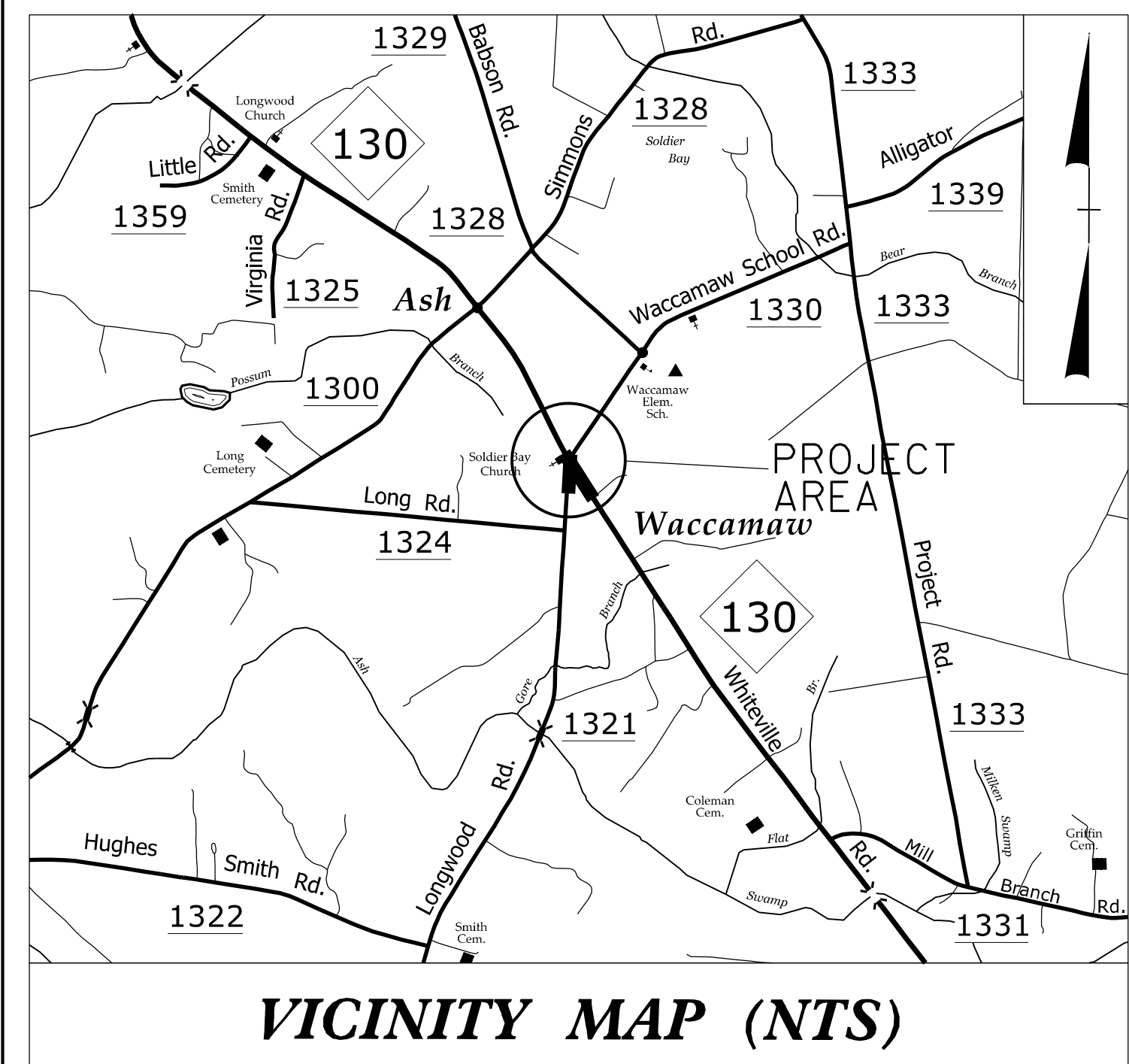

BRUNSWICK COUNTY

LOCATION: INTERSECTION OF NC 130 (WHITEVILLE RD.)
 AT SR 1321 (LONGWOOD RD.)
 TYPE OF WORK: GRADING, DRAINAGE, AND PAVING

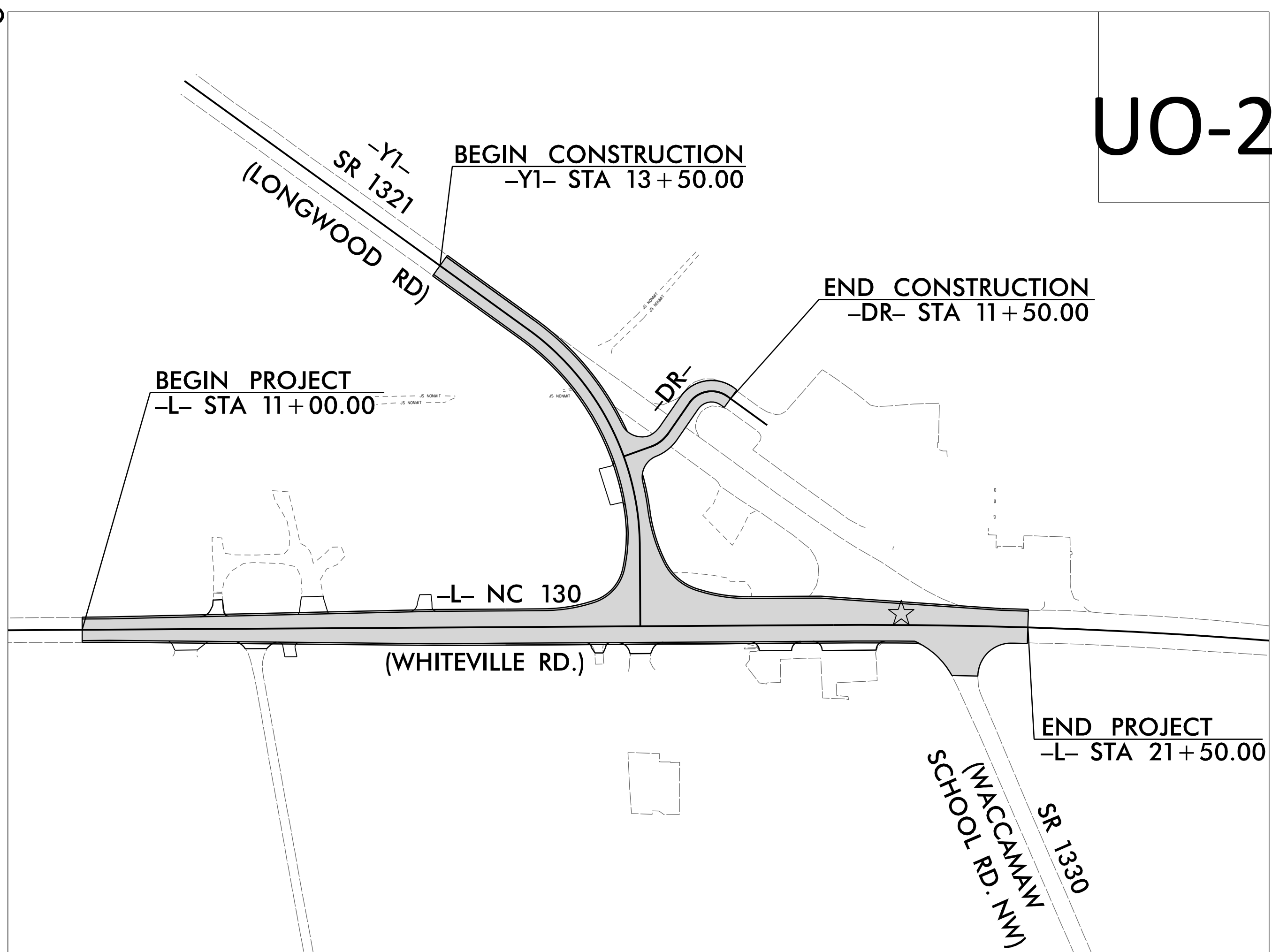
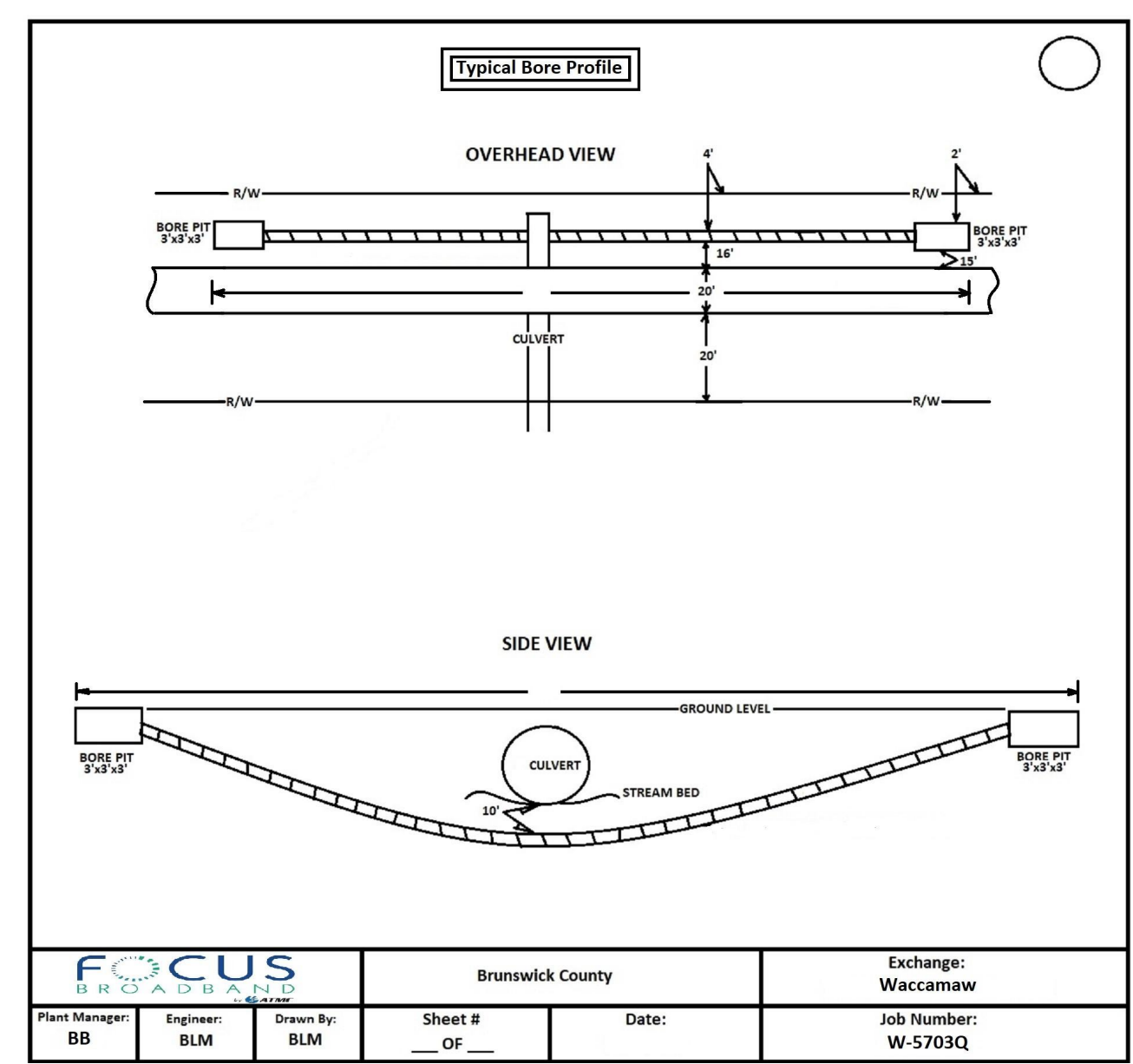
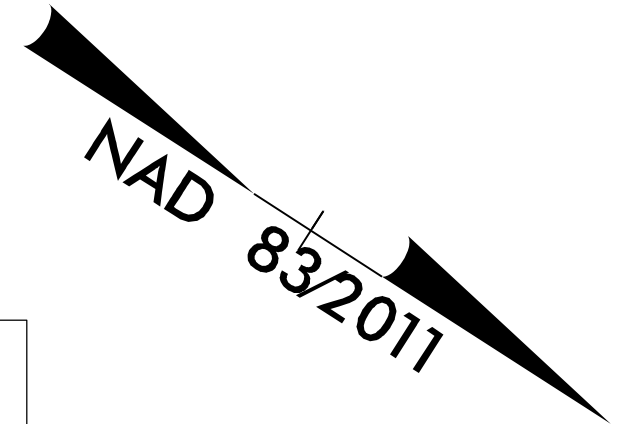

UO-2

☆ EXISTING SIGNAL TO BE REMOVED

DOCUMENT NOT CONSIDERED FINAL UNLESS ALL SIGNATURES COMPLETED

CONTRACT:

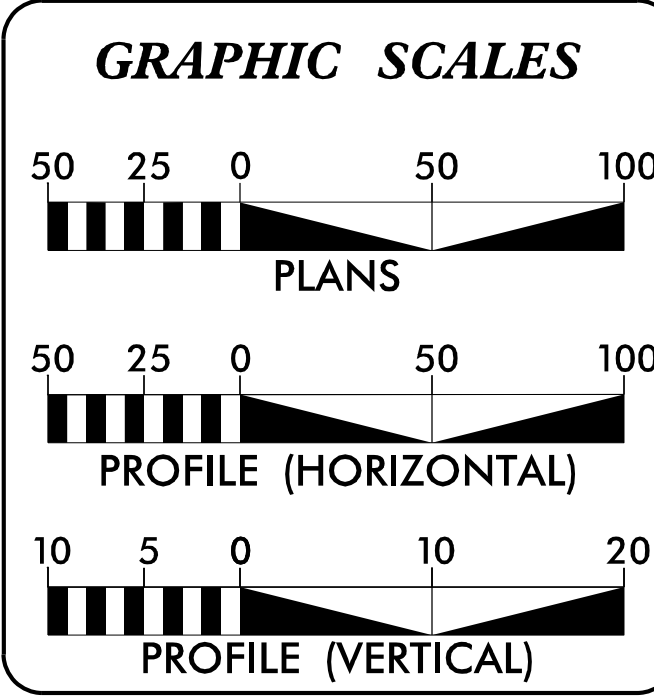

DESIGN DATA
 ADT -L- 2022 = 6730
 ADT -L- 2042 = 8060
 V = 60 MPH
 FUNC CLASS = MINOR ARTERIAL

PROJECT LENGTH
 LENGTH ROADWAY TIP PROJECT W-5703Q = 0.199 MILES
 TOTAL LENGTH TIP PROJECT W-5703Q = 0.199 MILES

ERIC MURRAY
 NCDOT CONTACT, DIVISION 3

Prepared in the Office of:

 320 Executive Ct.
 Hillsborough, NC 27278-8551
 Voice: (919) 732-3883
 Fax: (919) 732-6776
 www.summitde.net

2018 STANDARD SPECIFICATIONS

RIGHT OF WAY DATE: DECEMBER 28, 2018
 LETTING DATE: APRIL 21, 2022

BRANDON W. JOHNSON, PE
 PROJECT ENGINEER

FAITH E. JAHNKE, PE
 PROJECT DESIGN ENGINEER

HYDRAULICS ENGINEER

SIGNATURE: _____ P.E.

ROADWAY DESIGN ENGINEER

SIGNATURE: _____ P.E.

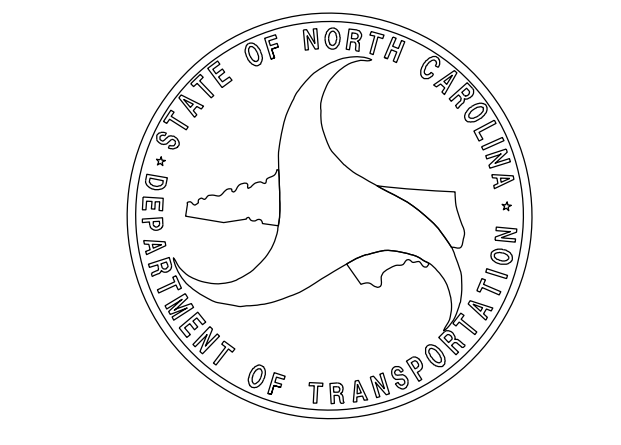

12-JAN-2022 20:57
 W5703Q_Rcy_Tsh.dgn
 Faith, Jahnke

PROJECT REFERENCE NO.	SHEET NO.
W-57030	UO-2
RW SHEET NO.	
ROADWAY DESIGN ENGINEER	HYDRAULICS ENGINEER

DOCUMENT NOT CONSIDERED FINAL UNLESS ALL SIGNATURES COMPLETED

Prepared in the Office of: **SUMMIT**

NC PERM LICENSE NO: P-0339
300 Executive Ct.
Hillsborough, NC 27278
(919) 732-3883
(919) 732-6616 (FAX)

FOR -L- PROFILE, SEE SHEET 5
FOR -YI- PROFILE, SEE SHEET 5
FOR -DR- PROFILE, SEE SHEET 5

PAVEMENT REMOVAL

REMOVE EXISTING SIGNAL

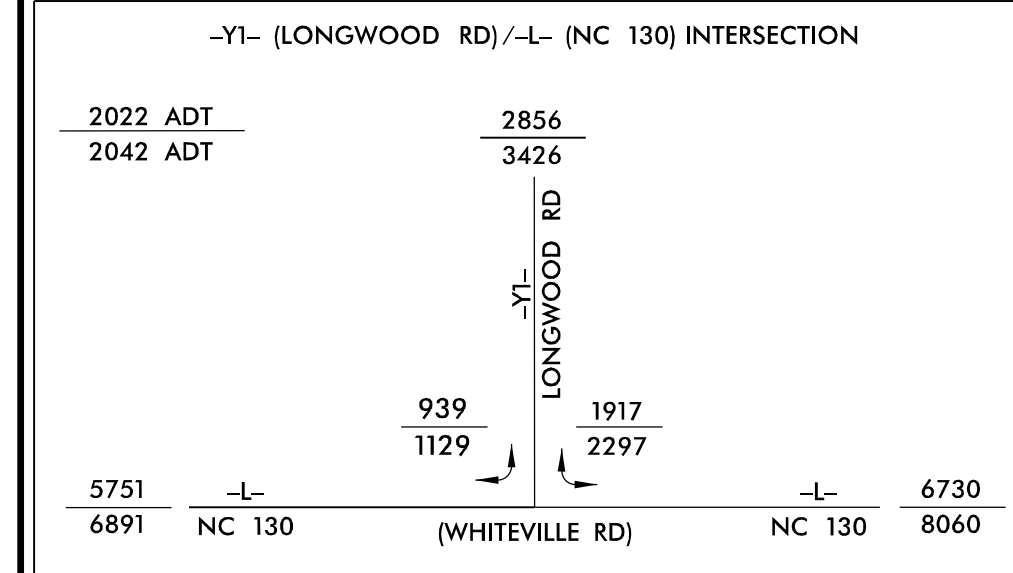
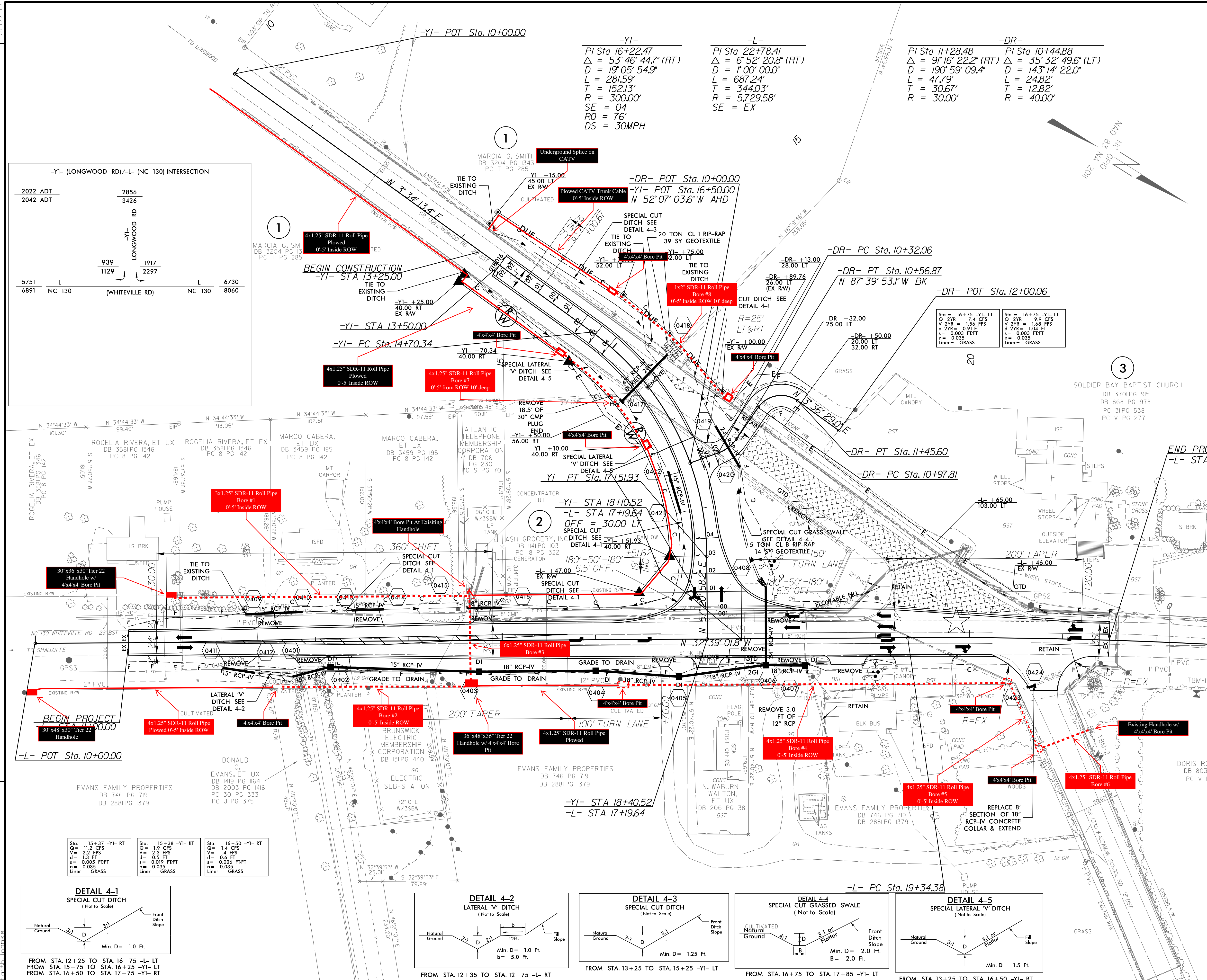

Sta = 15+37 -YI- RT Q = 11.2 CFS V = 2.2 FPS d = 1.3 FT s = 0.005 FT/FT n = 0.035 Liner = GRASS	Sta = 15+38 -YI- RT Q = 1.9 CFS V = 2.3 FPS d = 0.5 FT s = 0.019 FT/FT n = 0.035 Liner = GRASS	Sta = 16+50 -YI- RT Q = 1.4 CFS V = 1.4 FPS d = 0.4 FT s = 0.006 FT/FT n = 0.035 Liner = GRASS
---	--	--

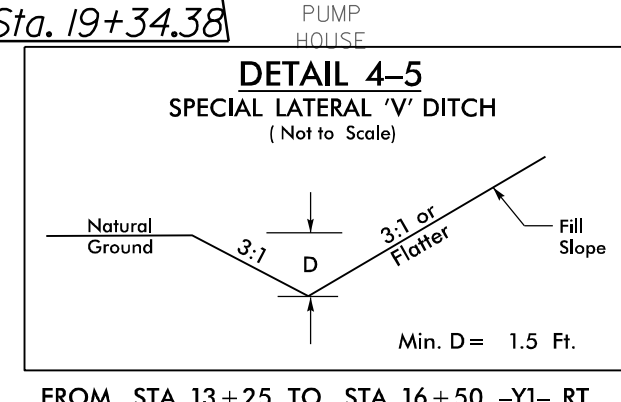
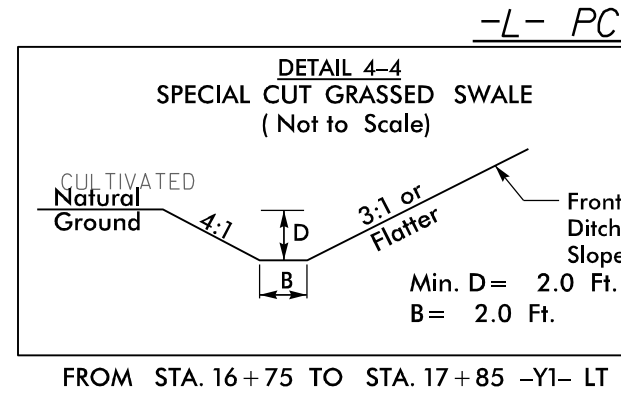
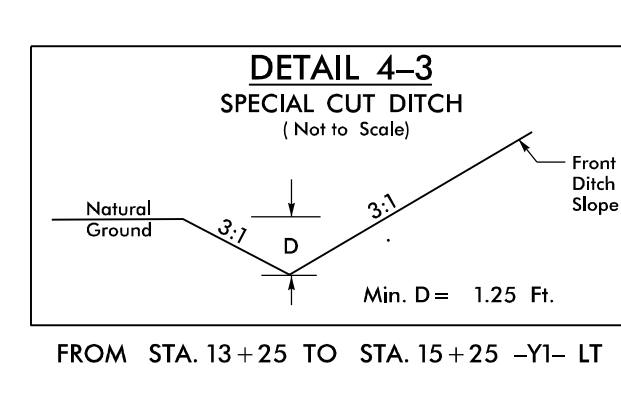
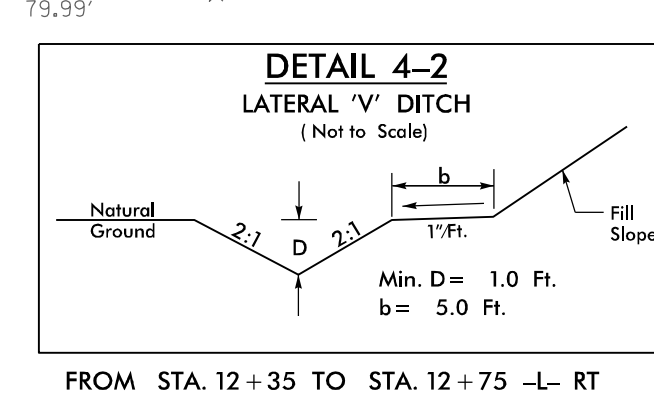
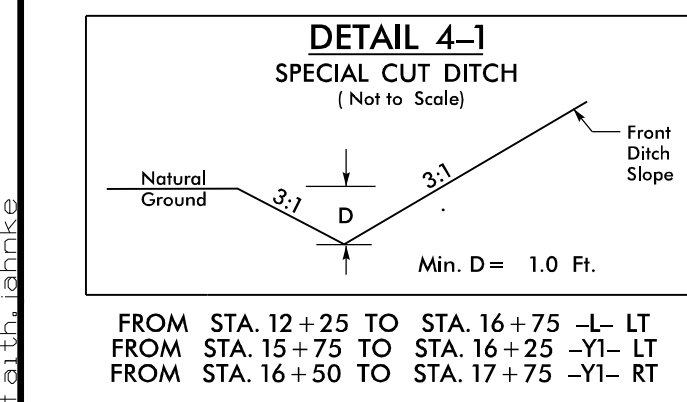

REVISIONS

8.17.79

12-15-2022 20:57
W-57030-PC-Plan-4.dgn
F:\b\blnk

CROSS SECTION INDEX

PROJECT NO. W-5703Q

ALIGNMENT	SHEET NUMBER
L	X-1 TO X-8
Y1	X-9 TO X-12
DR	X-13 TO X-14

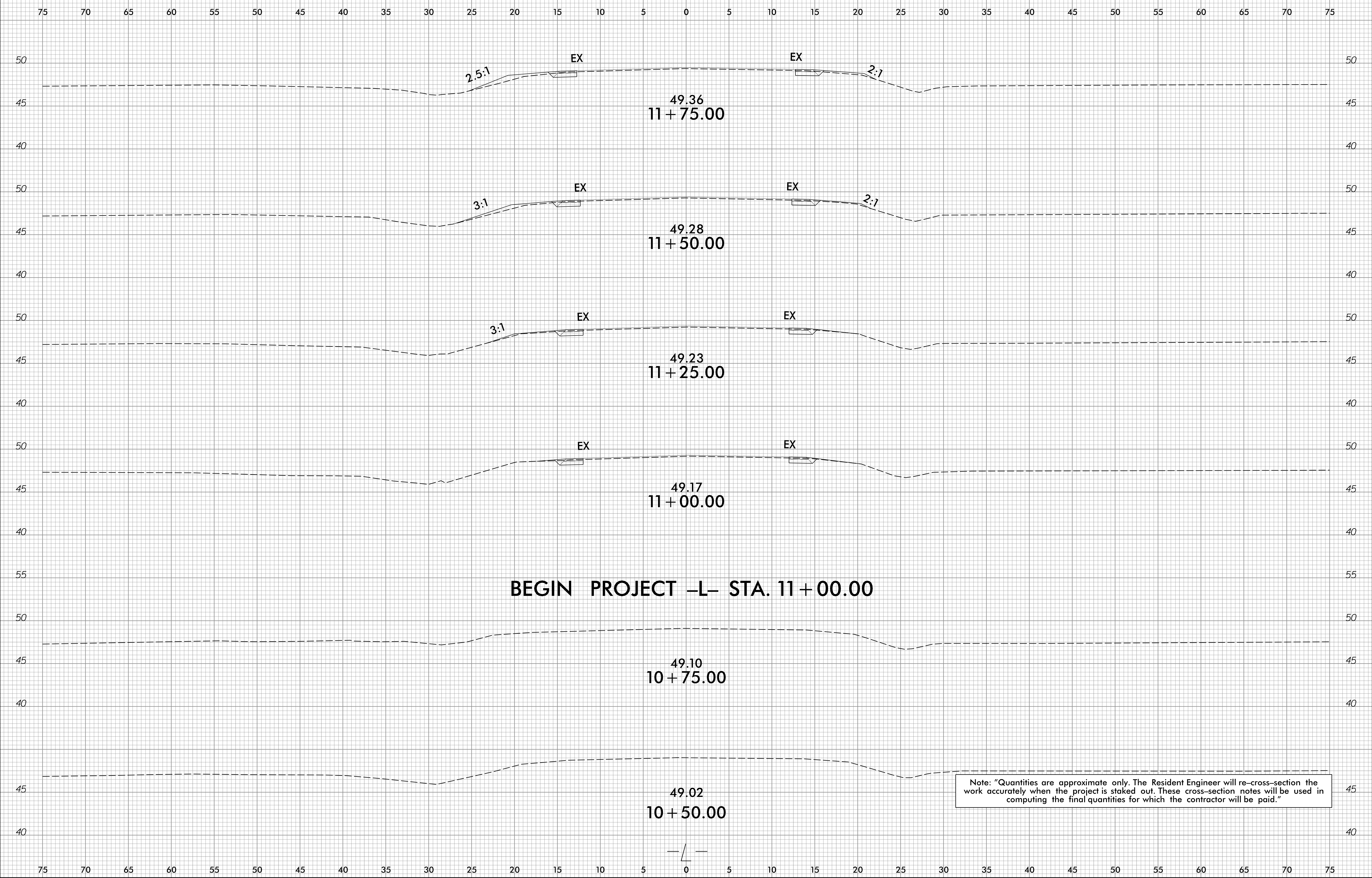

BEGIN PROJECT -L- STA. 11 + 00.00

Note: "Quantities are approximate only. The Resident Engineer will re-cross-section the work accurately when the project is staked out. These cross-section notes will be used in computing the final quantities for which the contractor will be paid."

01-MAR-2022 11:26 W57030_R001_xpl_L.dgn

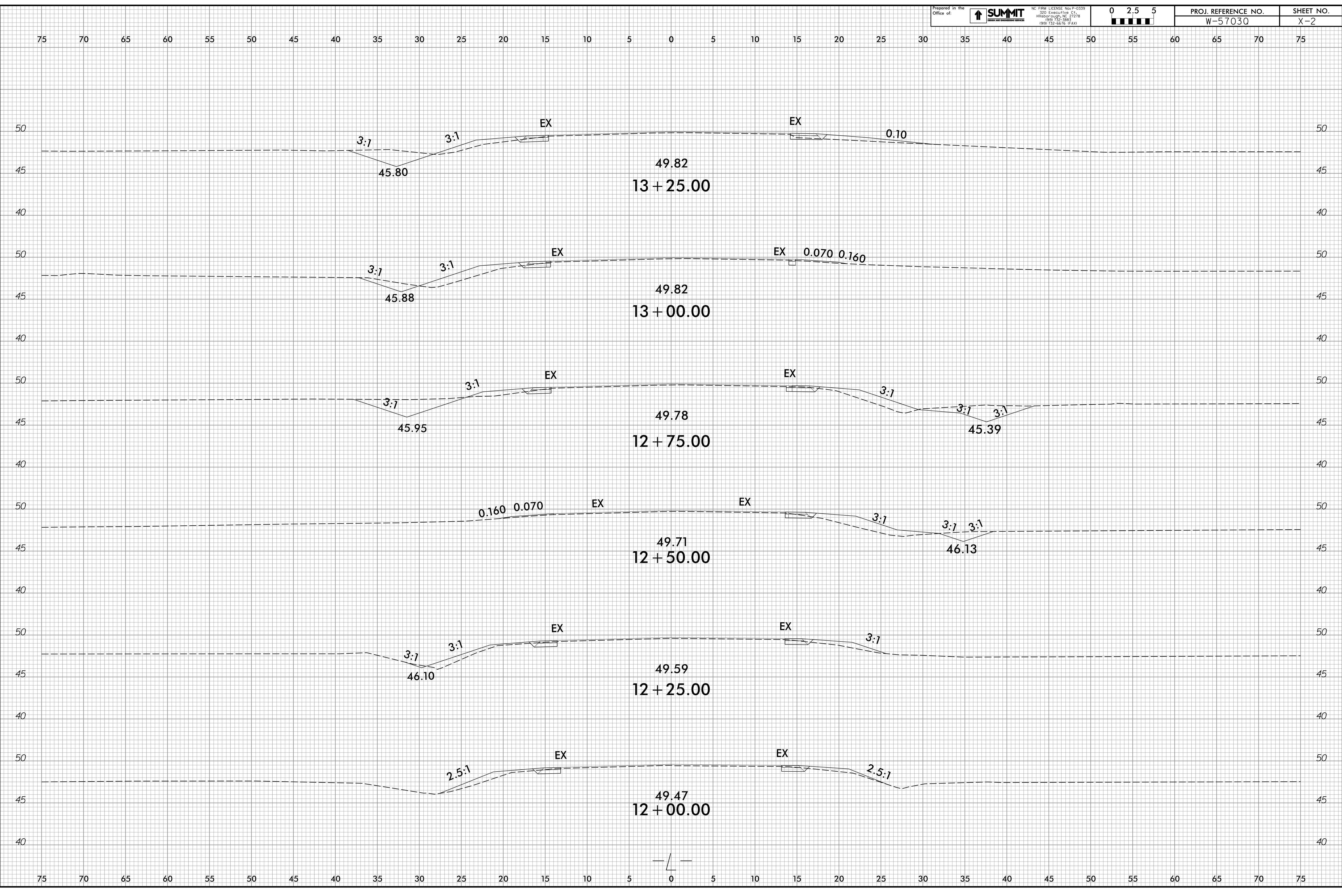

01-MAR-2022 11:26
 W57030_Road_xpl_L.dgn
 at:lgm/mke

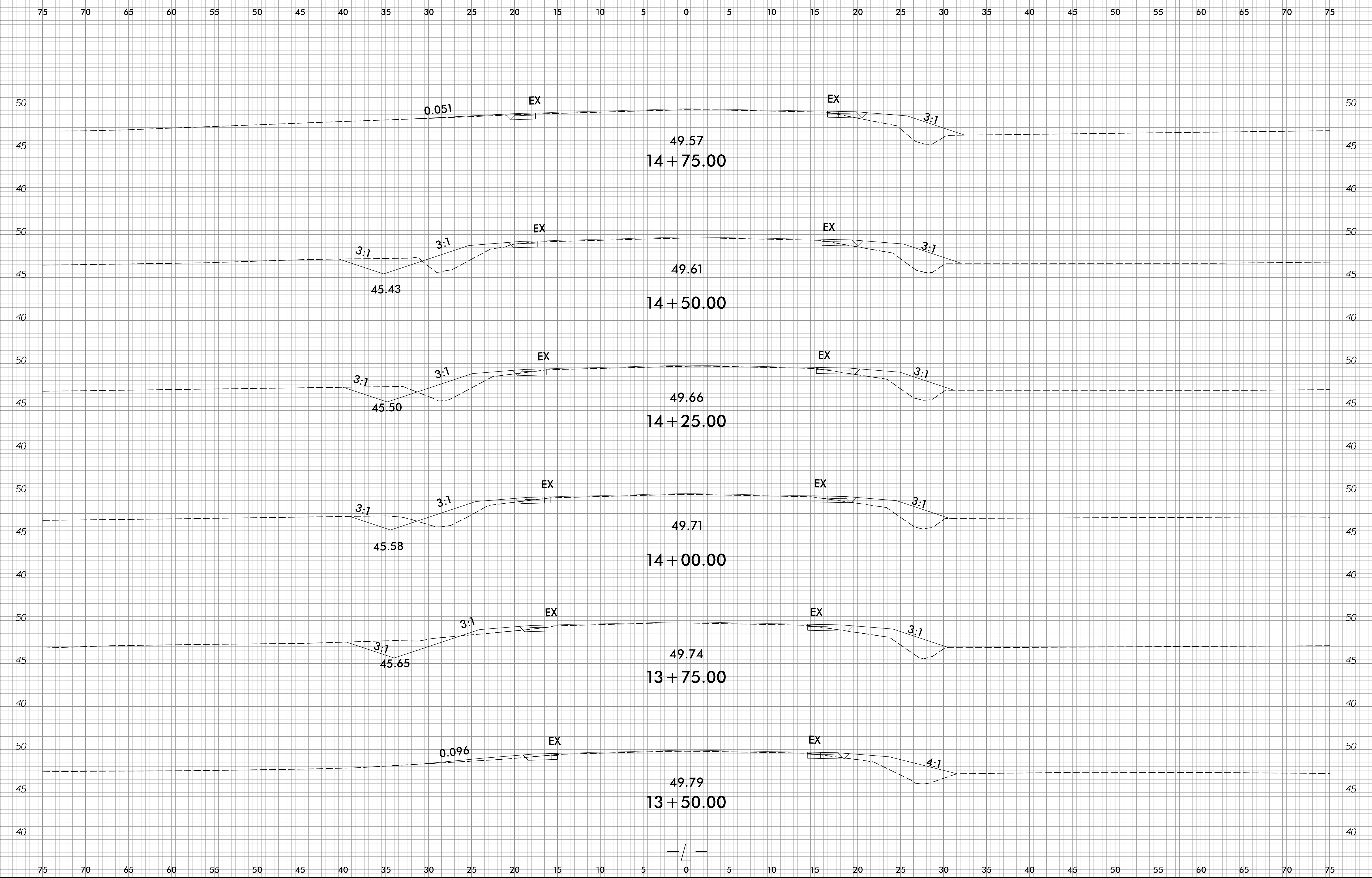

O:\MAP-2022\1126
 W57030_Road_xpl.dgn
 at:lgm/ke

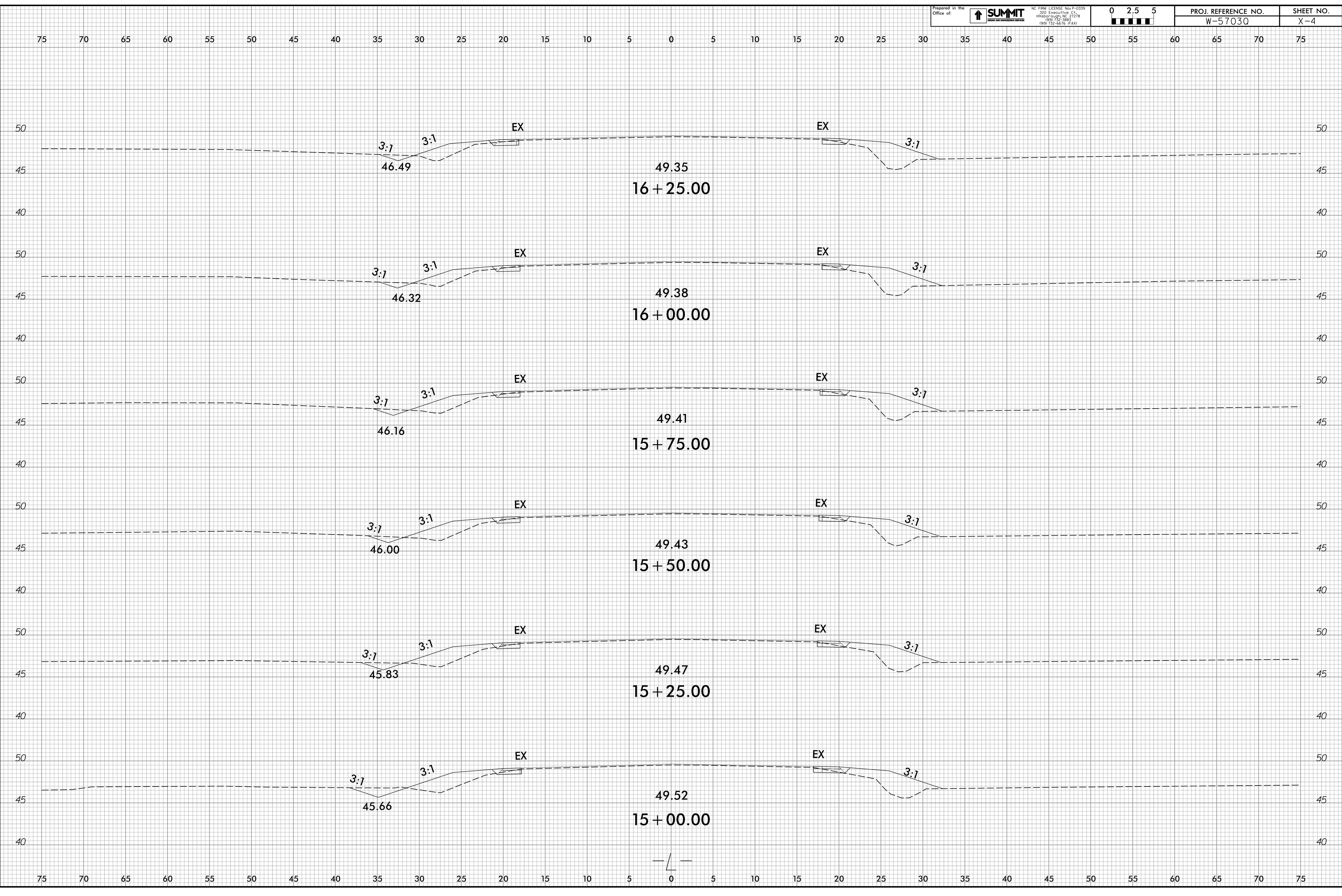

01-MAR-2022 11:26
 W57030_Road_xpl.dgn
 at:lgm/ke

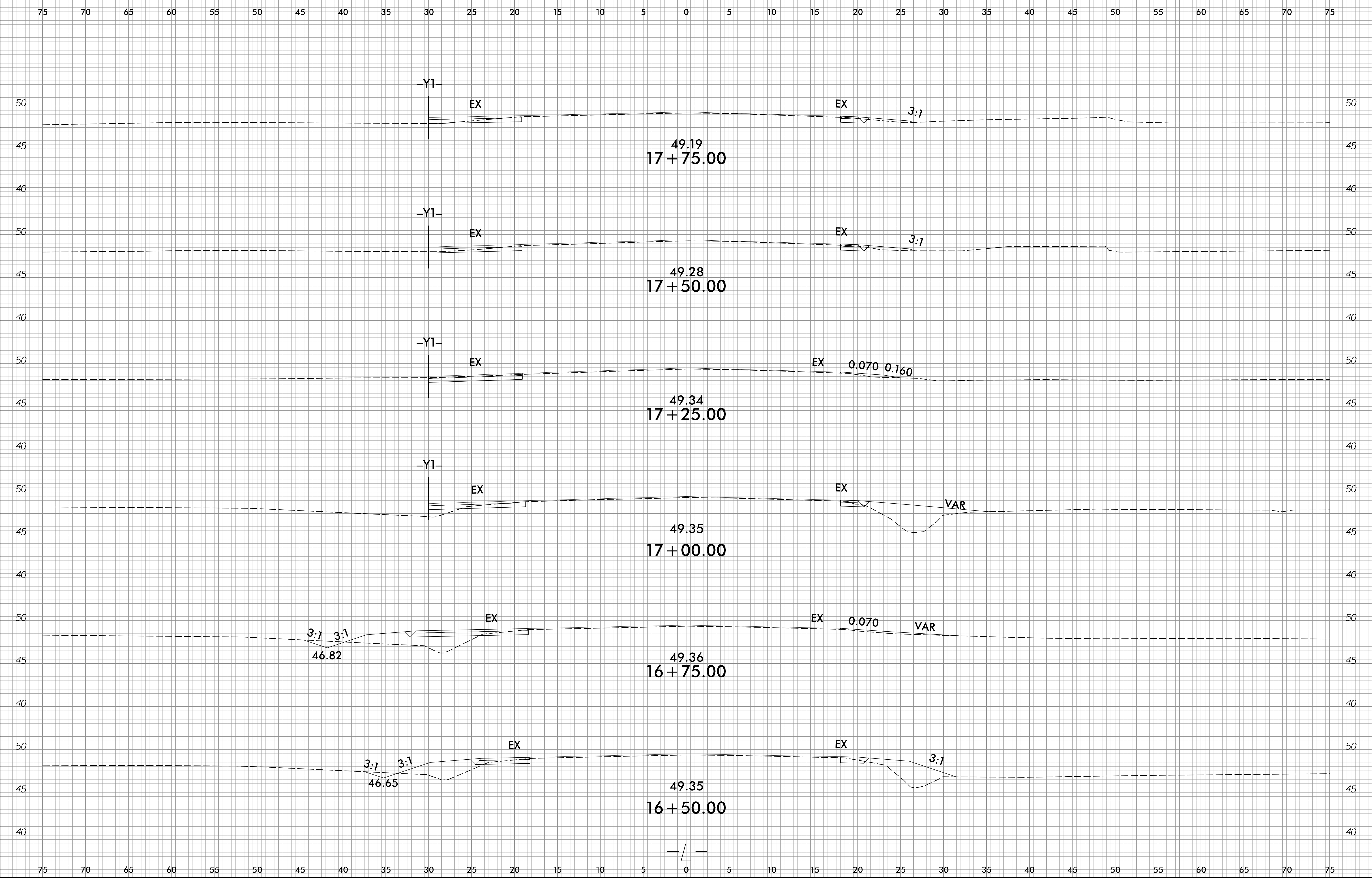

01-MAR-2022 11:26
 W57030_Road_xpl.dgn
 at:lgm/ke

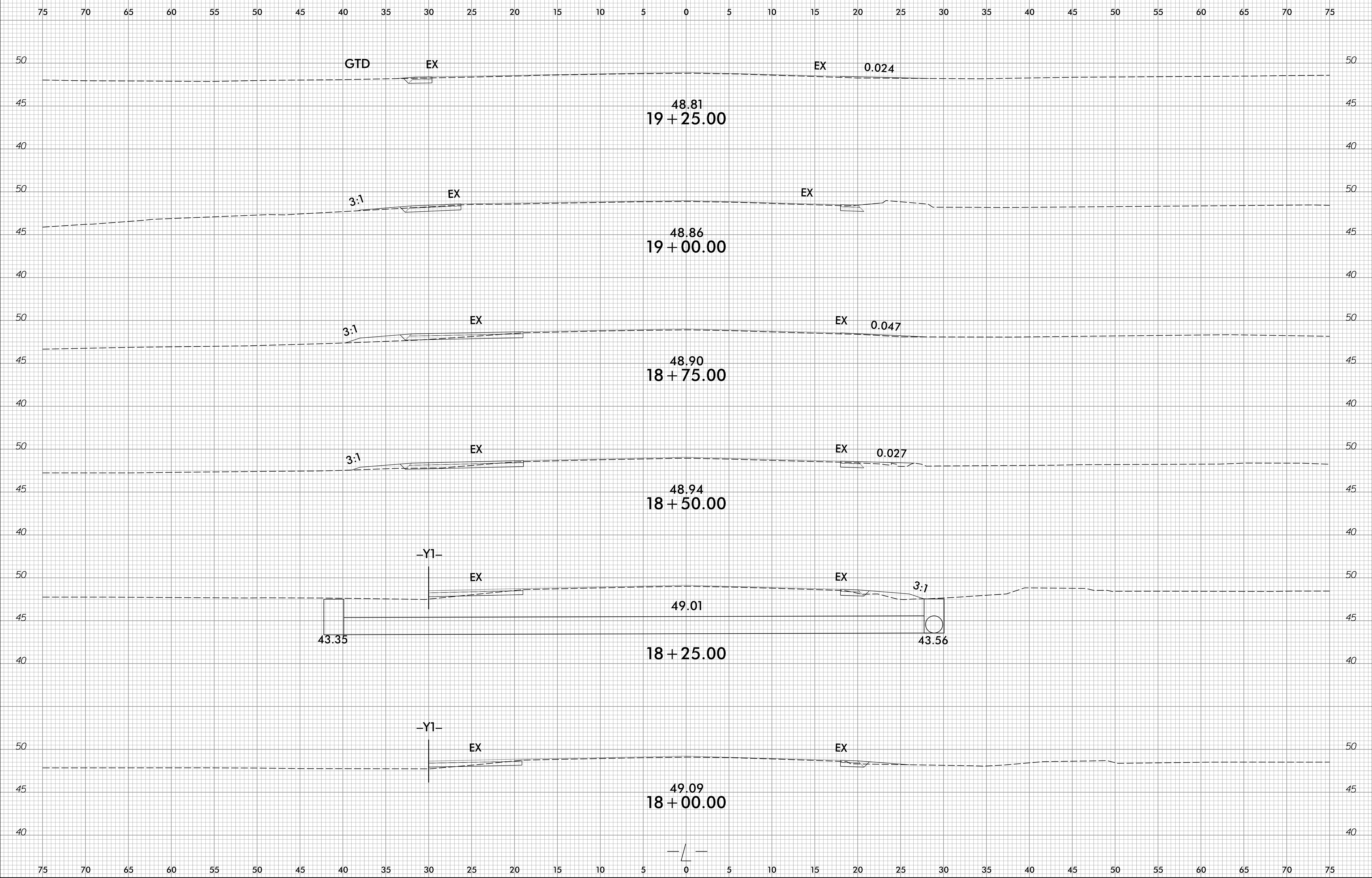

01-MAR-2022 11:26
W57030_Road_xpl_L.dgn
at:lgm/ke

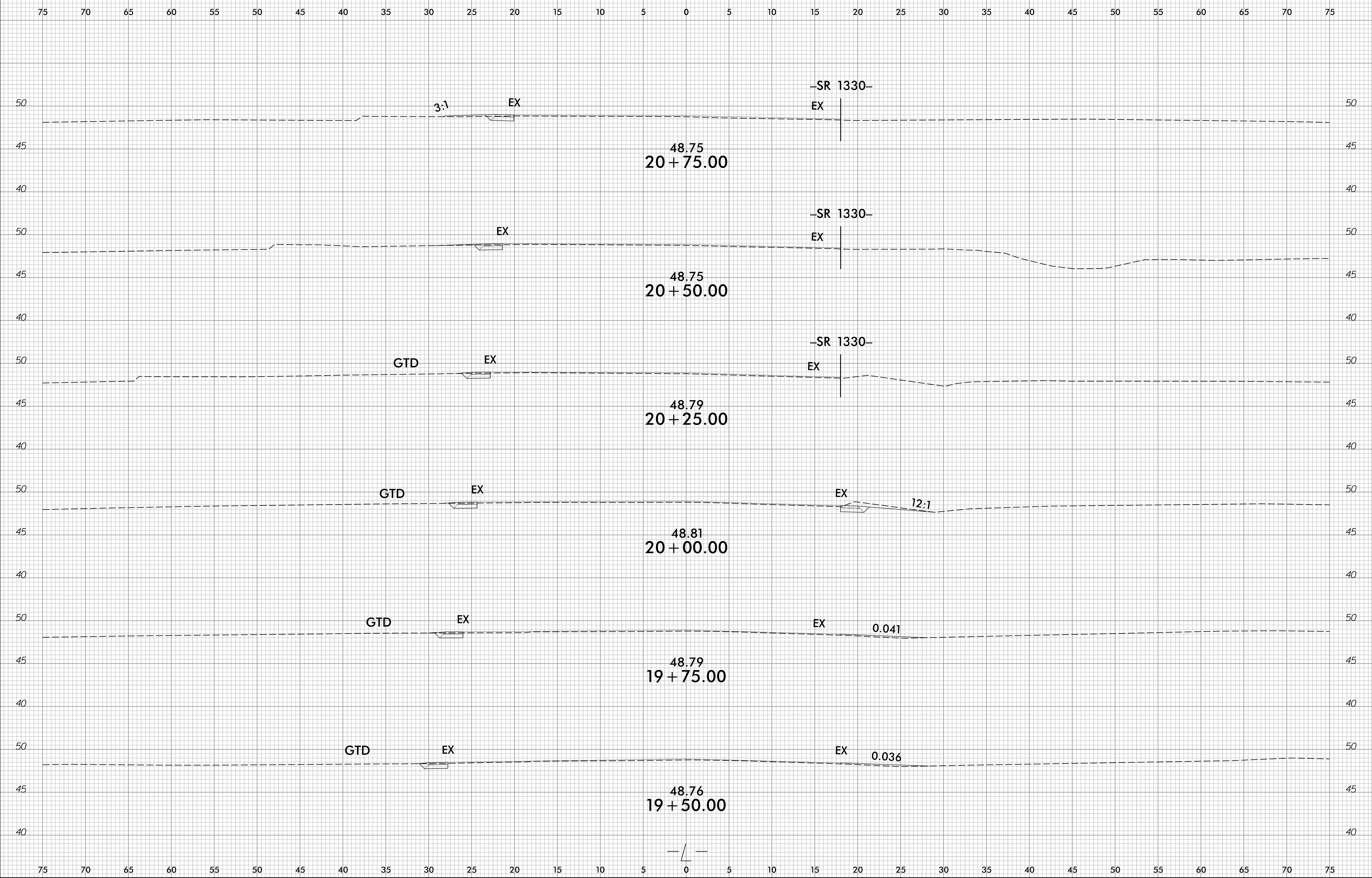

01-MAR-2022 11:26
 W57030_Road_xpl.dgn
 at:lgm/ke

75 70 65 60 55 50 45 40 35 30 25 20 15 10 5 0 5 10 15 20 25 30 35 40 45 50 55 60 65 70 75

48.63
22 + 00.00

48.64
21 + 75.00

END PROJECT -L- STA. 21 + 50.00

48.66
21 + 50.00

48.69
21 + 25.00

48.75
21 + 00.00

EX

EX

3:1

EX

-SR 1330-

EX

EX

-SR 1330-

EX

75 70 65 60 55 50 45 40 35 30 25 20 15 10 5 0 5 10 15 20 25 30 35 40 45 50 55 60 65 70 75

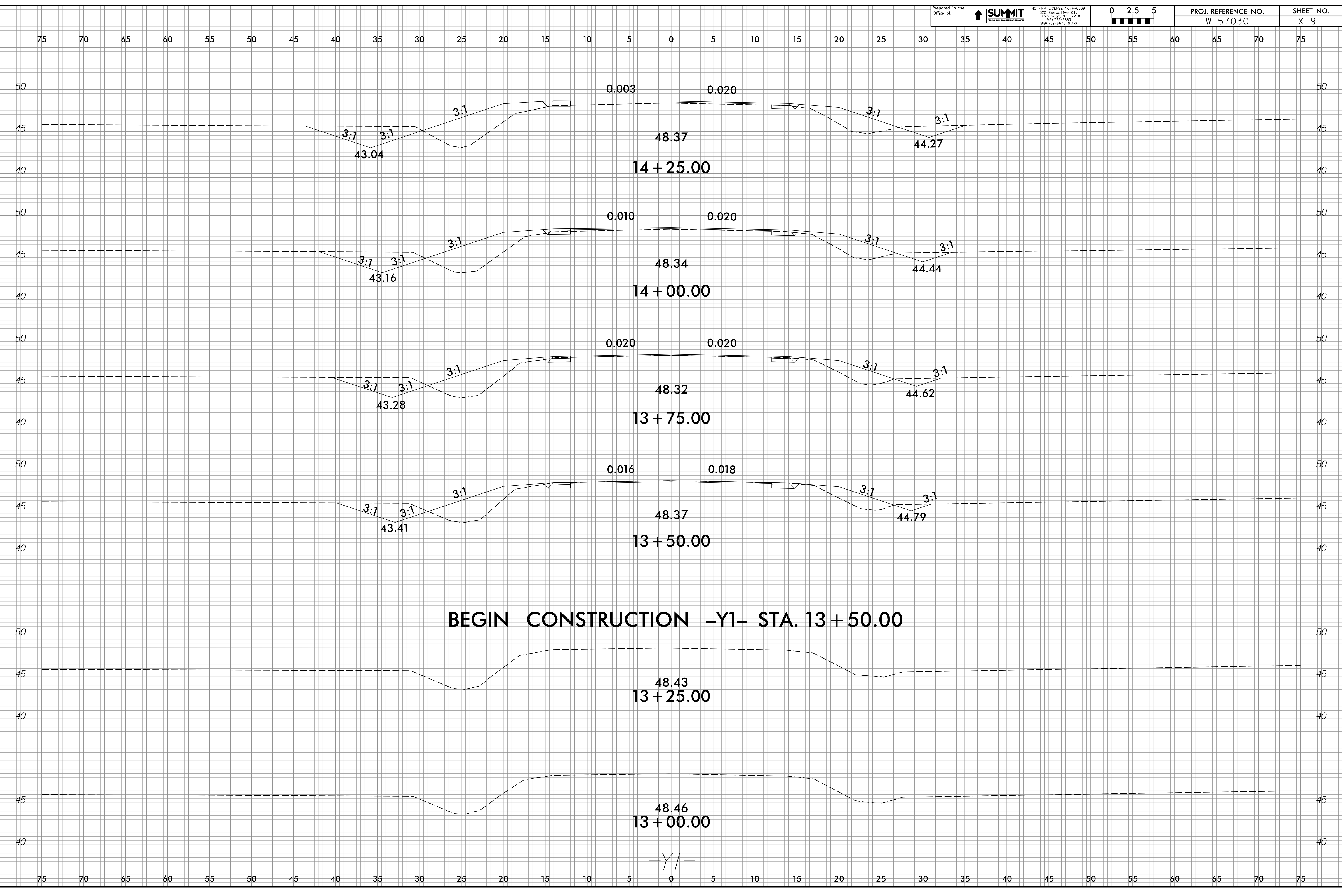

BEGIN CONSTRUCTION -Y1- STA. 13 + 50.00

O:\MAP-2022\1126
 W57030_Road_xpl_Y1.dgn
 at:lgm/ke

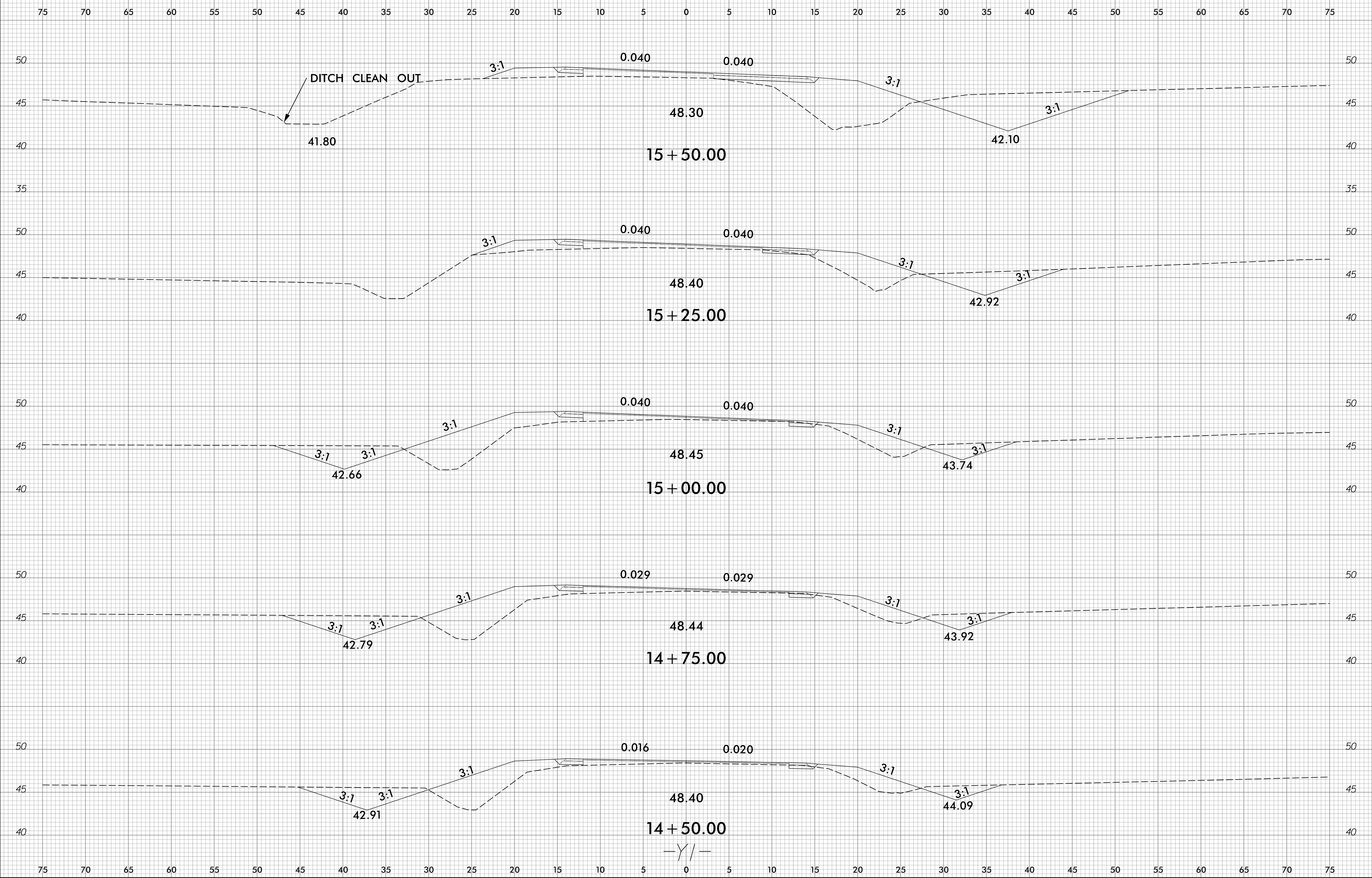

01-MAR-2022 11:26
 W57030_R001_xpl_1.dgn
 at:lgm/ke

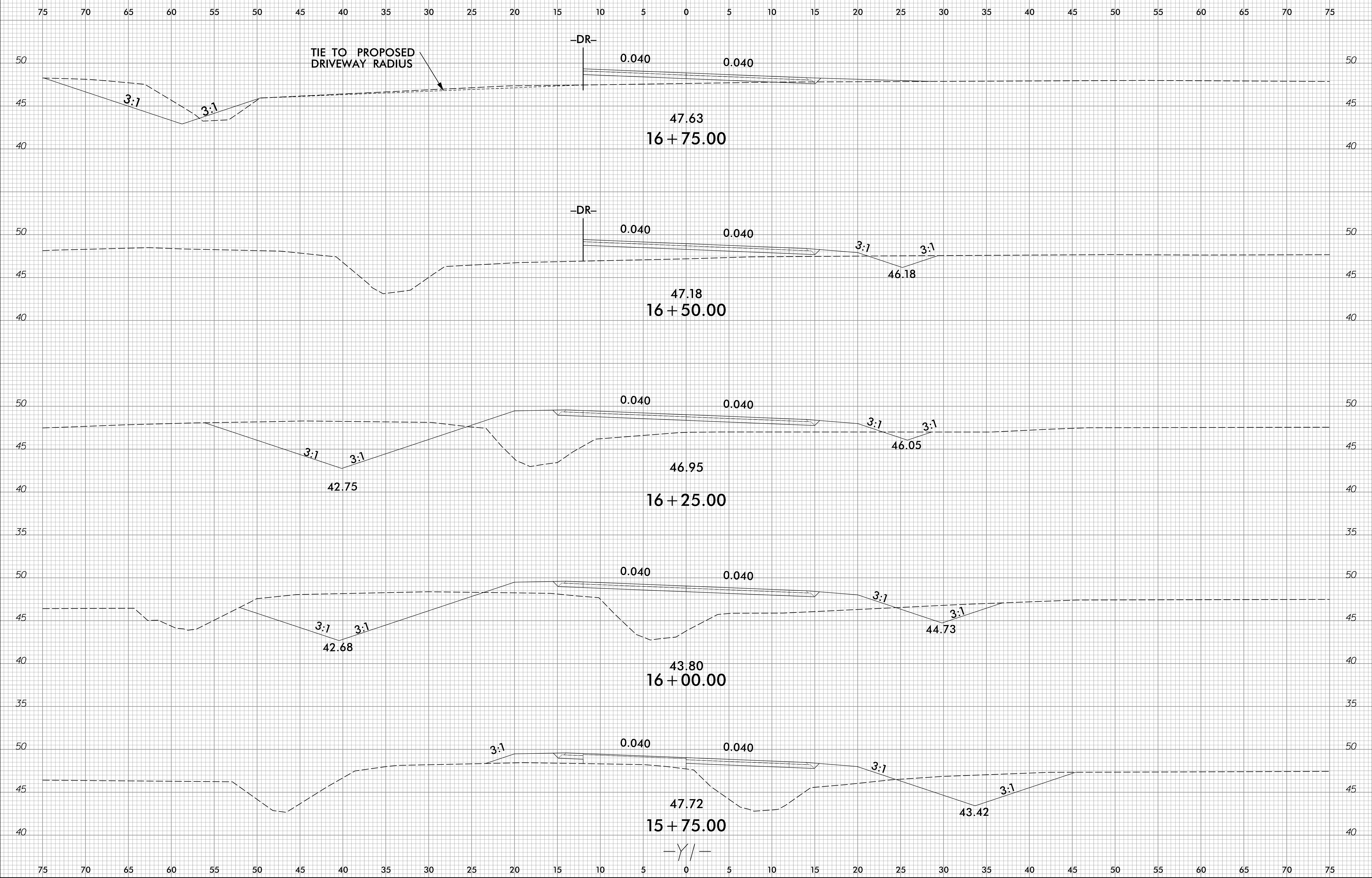

01-MAR-2022 11:26
 W57030_Road_xpl_1.dgn
 at:lgm/ke

75 70 65 60 55 50 45 40 35 30 25 20 15 10 5 0 5 10 15 20 25 30 35 40 45 50 55 60 65 70 75

END CONSTRUCTION -Y1- STA. 18+10.52

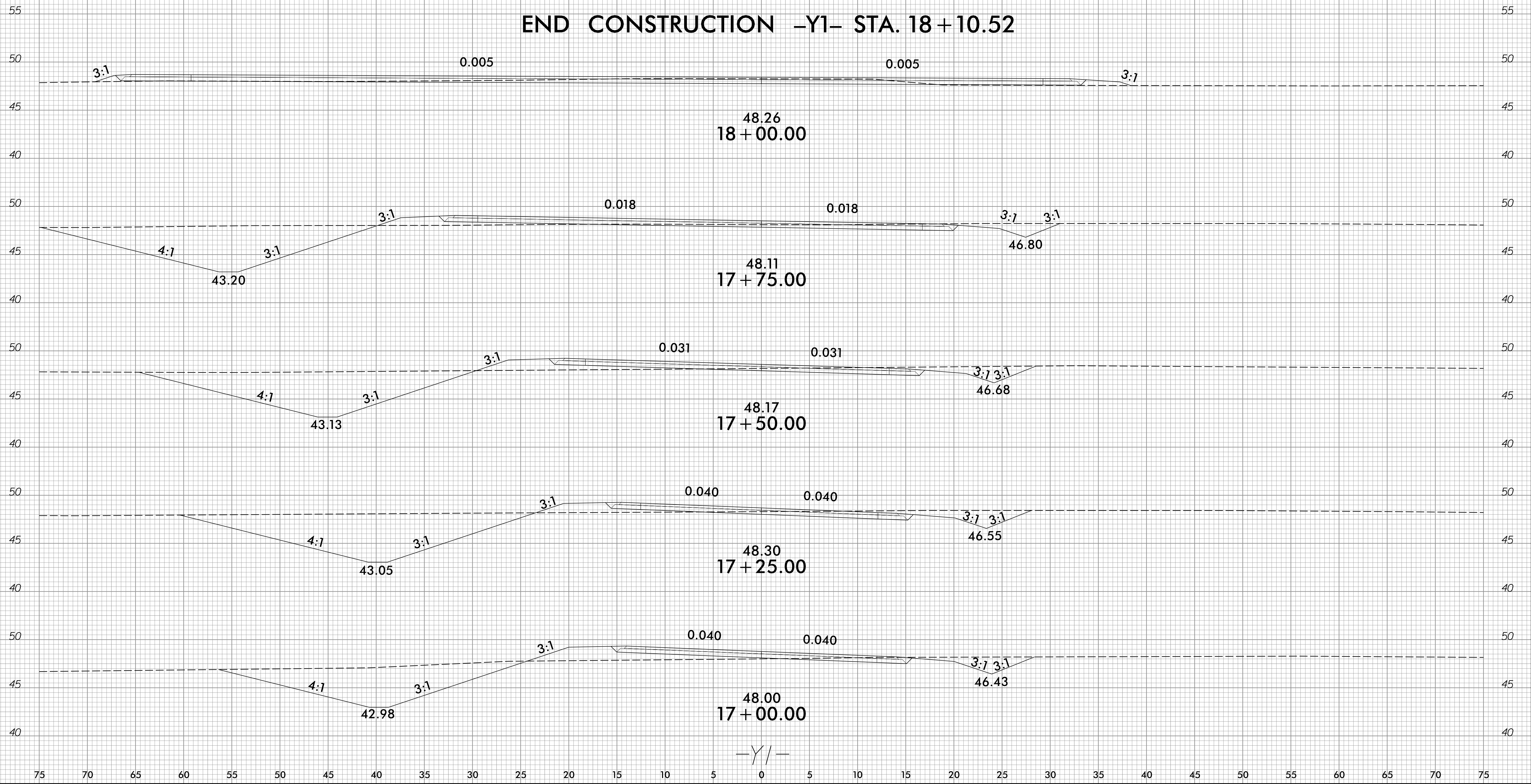

01-MAR-2022 11:26
 W57030_Road_xpl_Y1.dgn
 at:ljg/mke

75 70 65 60 55 50 45 40 35 30 25 20 15 10 5 0 5 10 15 20 25 30 35 40 45 50 55 60 65 70 75

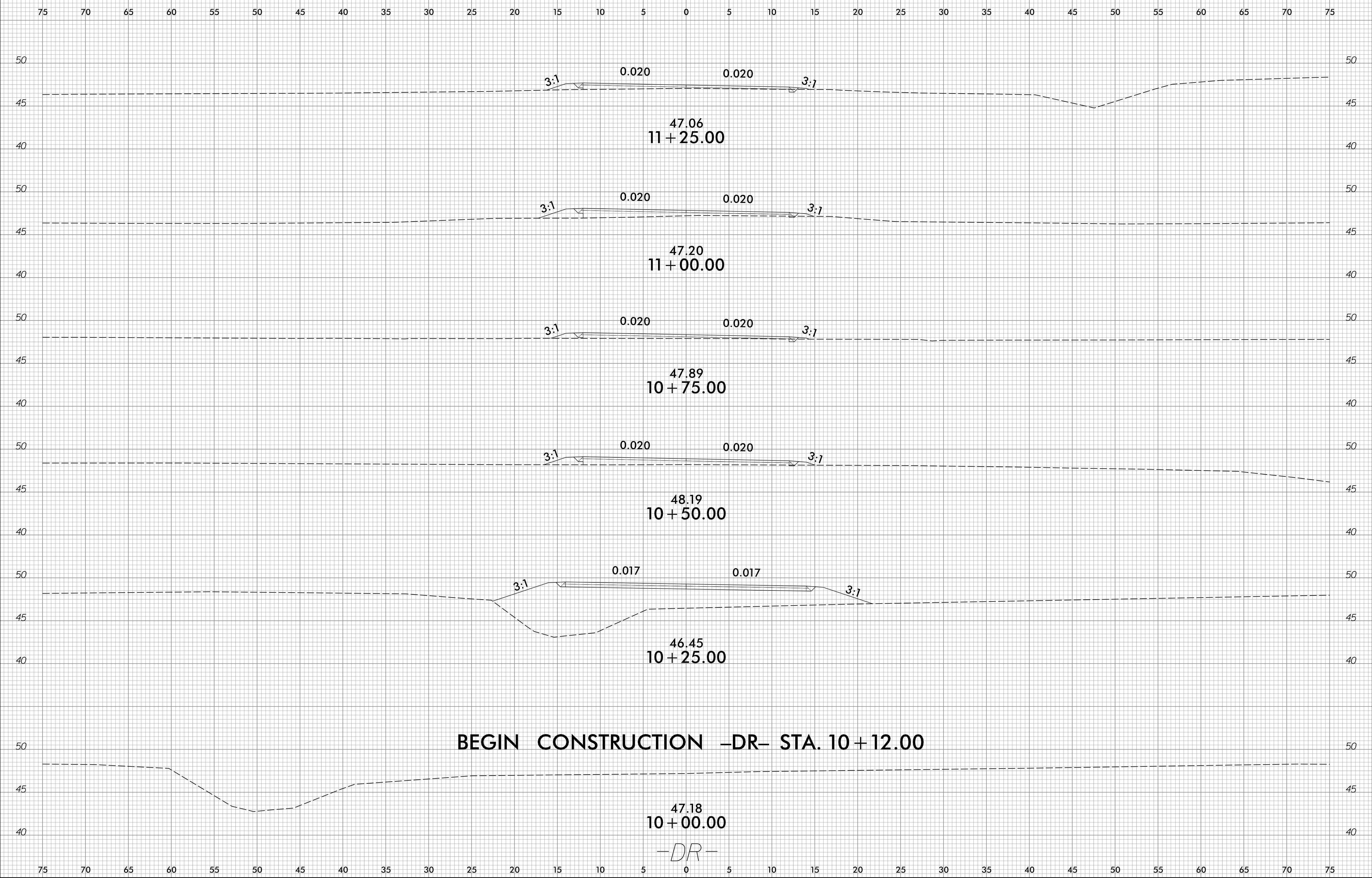

01-MAR-2022 11:26
 W57030_Road_xpl_DR.dgn
 at:lgm/ke

75 70 65 60 55 50 45 40 35 30 25 20 15 10 5 0 5 10 15 20 25 30 35 40 45 50 55 60 65 70 75

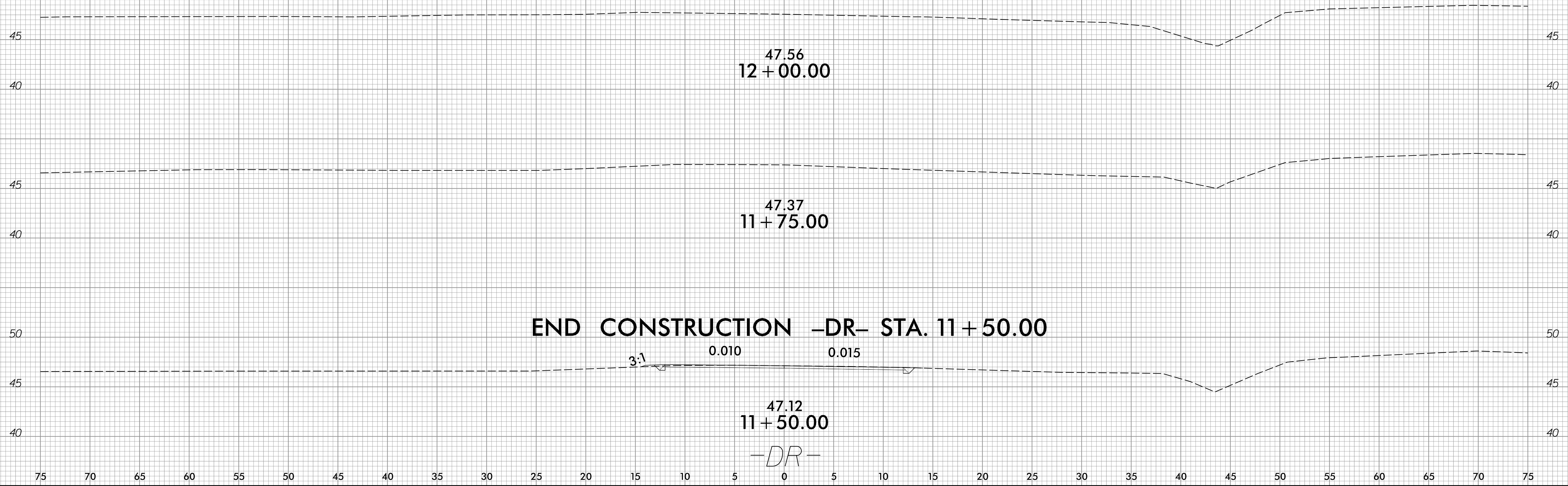

O:\MAP-2022\1126
 W57030_Road_xpl_DR.dgn
 at:lgm/ke