

# TOWN OF BURGAW

## WALKER ST (HWY 117) SIDEWALK ENCROACHMENT

MC PROJECT NO. 4576-0007

AUGUST 2014

### BOARD OF COMMISSIONERS

EUGENE MULLIGAN, MAYOR  
HOWARD N. WALKER JR., MAYOR PRO-TEM  
CHARLES M. ROOKS, COMMISSIONER  
JAN DAWSON, COMMISSIONER  
ELAINE B. TYSON, COMMISSIONER  
WILFRED L. ROBBINS, COMMISSIONER

### TOWN MANAGER

CHAD MCEWEN

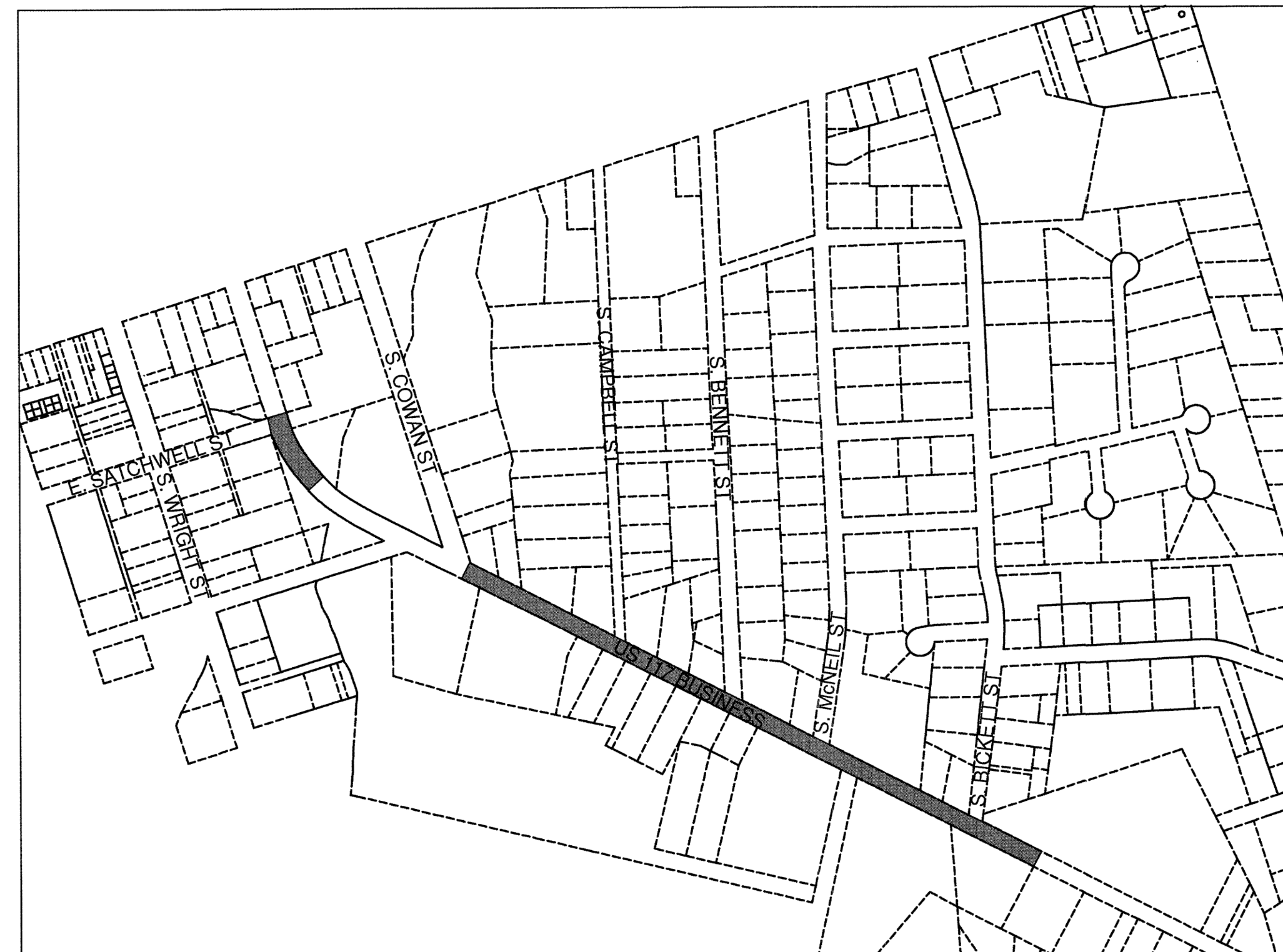

PROPOSED IMPROVEMENTS INCLUDE THE INSTALLATION OF APPROXIMATELY 3,200 LINEAR FEET OF 5' CONCRETE AND ASPHALT SIDEWALK AND RELATED UTILITY IMPROVEMENTS ALONG WALKER STREET (NC HWY 117) IN THE TOWN OF BURGAW, PENDER COUNTY, NC.

ISSUED FOR PERMITTING  
NOT FOR CONSTRUCTION

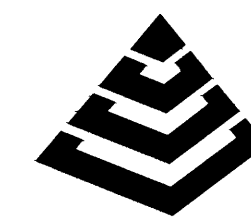
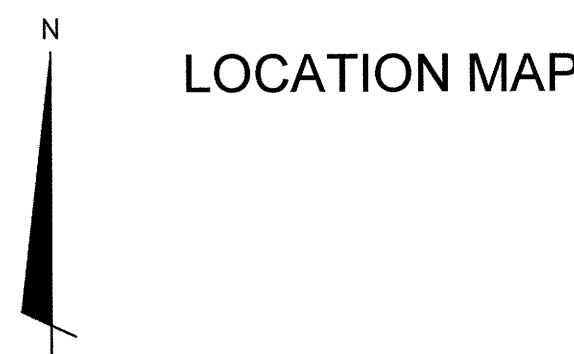

**MCKIM & CREED**

243 North Front Street  
Wilmington, North Carolina 28401  
Phone: (910)343-1048 , Fax: (910)251-8282

NC FIRM LICENSE F-1222

[www.mckimcreed.com](http://www.mckimcreed.com)

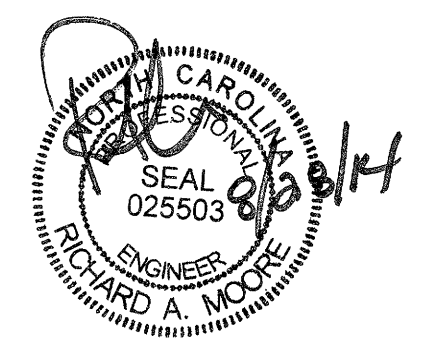
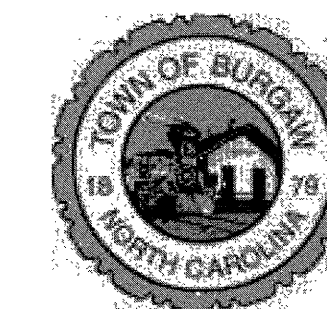

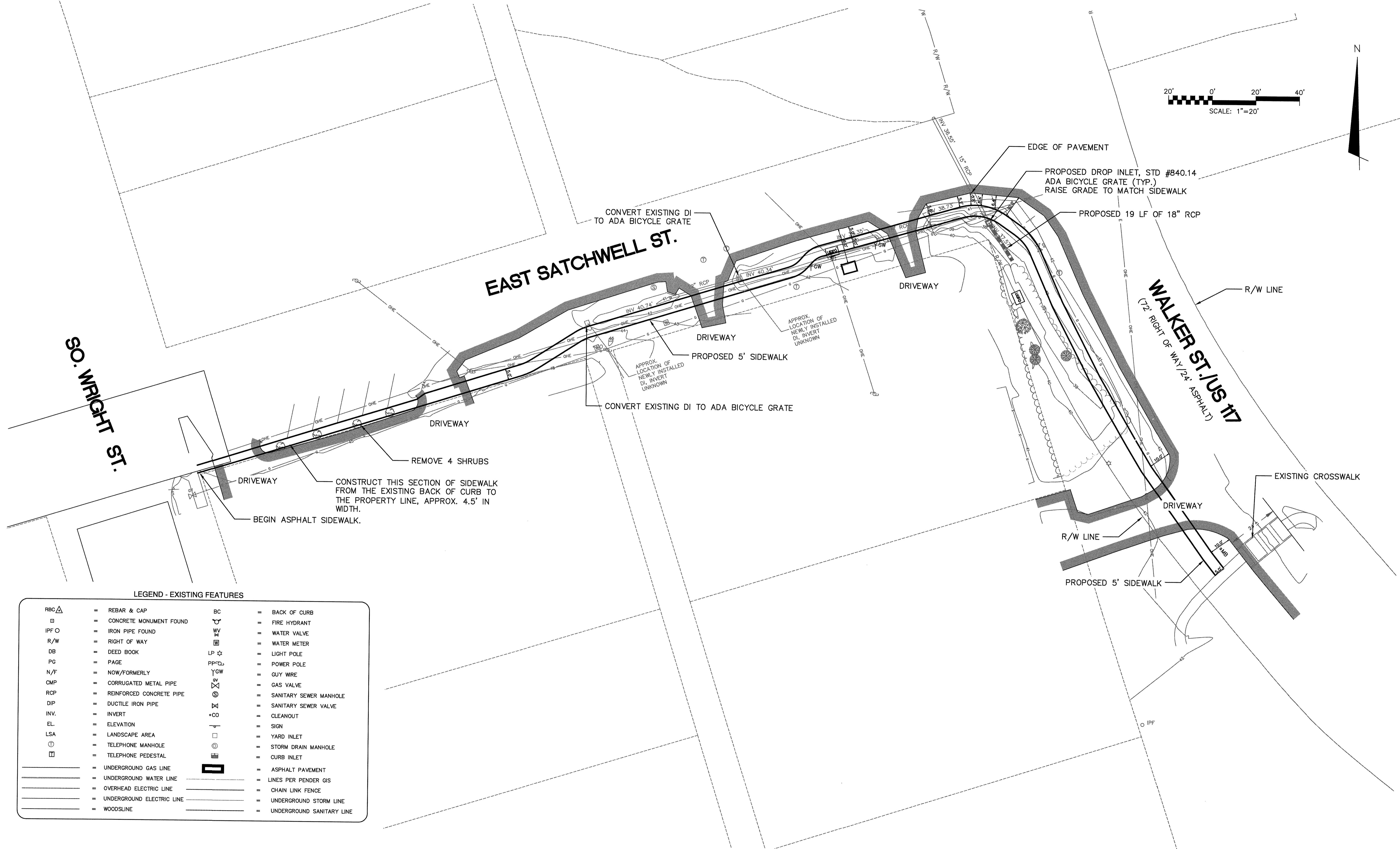
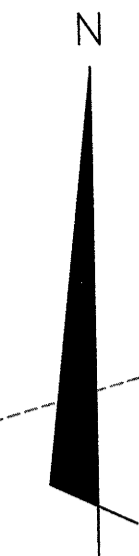
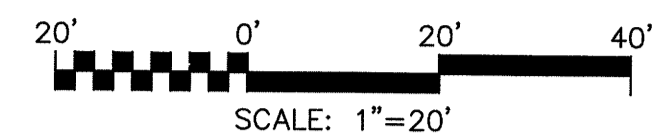

LEGEND - EXISTING FEATURES

RBC Δ	= REBAR & CAP	BC	= BACK OF CURB
□	= CONCRETE MONUMENT FOUND	⊕	= FIRE HYDRANT
IPFO	= IRON PIPE FOUND	W	= WATER VALVE
R/W	= RIGHT OF WAY	WM	= WATER METER
DB	= DEED BOOK	LP ☆	= LIGHT POLE
PG	= PAGE	PPPT	= POWER POLE
N/F	= NOW/FORMERLY	YGW	= GUY WIRE
CMP	= CORRUGATED METAL PIPE	⊗	= GAS VALVE
RCP	= REINFORCED CONCRETE PIPE	⊙	= SANITARY SEWER MANHOLE
DIP	= DUCTILE IRON PIPE	⊙	= SANITARY SEWER VALVE
INV.	= INVERT	⊙	= CLEANOUT
EL.	= ELEVATION	⊙	= SIGN
LSA	= LANDSCAPE AREA	⊙	= YARD INLET
⊙	= TELEPHONE MANHOLE	⊙	= STORM DRAIN MANHOLE
⊙	= TELEPHONE PEDESTAL	⊙	= CURB INLET
—	= UNDERGROUND GAS LINE	▭	= ASPHALT PAVEMENT
—	= UNDERGROUND WATER LINE	—	= LINES PER PENDER GIS
—	= OVERHEAD ELECTRIC LINE	—	= CHAIN LINK FENCE
—	= UNDERGROUND ELECTRIC LINE	—	= UNDERGROUND STORM LINE
—	= WOODLINE	—	= UNDERGROUND SANITARY LINE

S:\4576\000\80-Drawings\CS101\_045765007.dwg, 8/8/2014, 9:35:45 AM, rmcscor

REV. NO.	DESCRIPTIONS	DATE

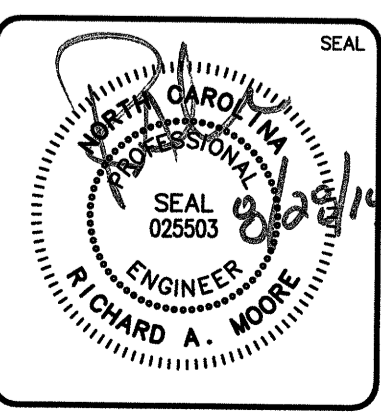
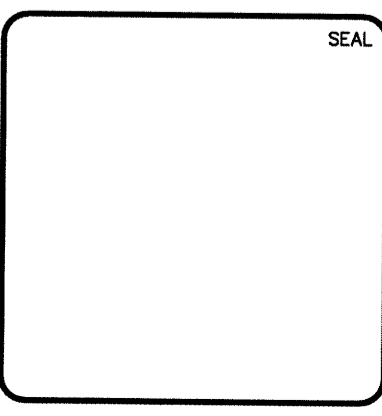

**MCKIM & CREED**  
 243 North Front Street  
 Wilmington, North Carolina 28401  
 Phone: (910)343-1048, Fax: (910)251-8282  
 NCFIRM LIC. F-1222  
 www.mckimcreed.com

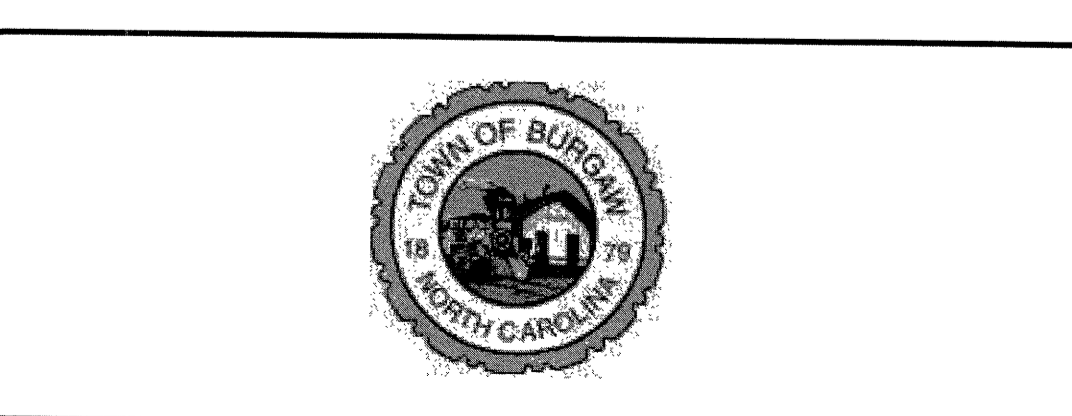

**Burgaw US 117/Walker Street**

---

**NC DOT ENCROACHMENT PLANS**

DATE: MAY 2014	SCALE	MAC FILE NUMBER
MCE PROJ. # 45760007	HORIZONTAL: N/A	CS101
DRAWN TCM	VERTICAL: N/A	DRAWING NUMBER
DESIGNED TCM		1
CHECKED RAM		
PROJ. MGR. RAM		
STATUS: ISSUED FOR PERMITTING	REVISION	

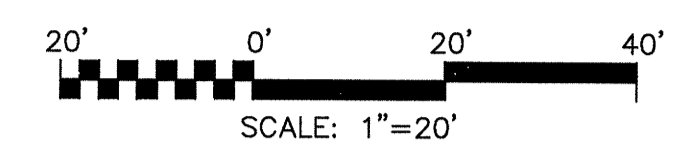
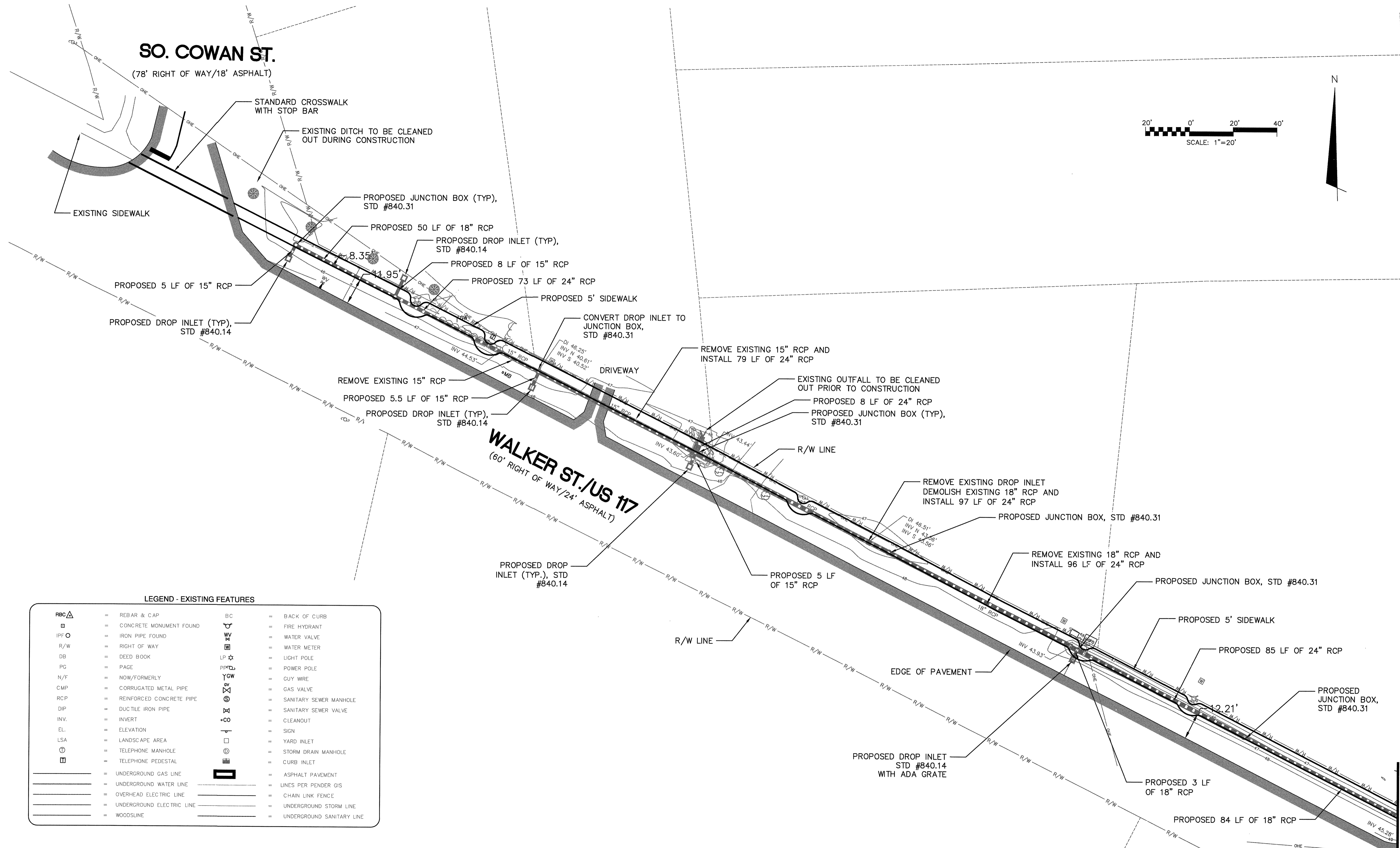

# SO. COWAN ST.

(78' RIGHT OF WAY/18' ASPHALT)

# WALKER ST./US 117

(60' RIGHT OF WAY/24' ASPHALT)

### LEGEND - EXISTING FEATURES

RBC Δ	= REBAR & CAP	BC	= BACK OF CURB
□	= CONCRETE MONUMENT FOUND	FH	= FIRE HYDRANT
IPF ○	= IRON PIPE FOUND	WV	= WATER VALVE
R/W	= RIGHT OF WAY	WM	= WATER METER
DB	= DEED BOOK	LP ⋆	= LIGHT POLE
PG	= PAGE	PPF ⚡	= POWER POLE
N/F	= NOW/FORMERLY	GW	= GUY WIRE
CMP	= CORRUGATED METAL PIPE	GV	= GAS VALVE
RCP	= REINFORCED CONCRETE PIPE	SM	= SANITARY SEWER MANHOLE
DIP	= DUCTILE IRON PIPE	SSV	= SANITARY SEWER VALVE
INV.	= INVERT	C	= CLEANOUT
EL.	= ELEVATION	S	= SIGN
LSA	= LANDSCAPE AREA	YI	= YARD INLET
TM	= TELEPHONE MANHOLE	SDM	= STORM DRAIN MANHOLE
TP	= TELEPHONE PEDESTAL	CI	= CURB INLET
UGL	= UNDERGROUND GAS LINE	AP	= ASPHALT PAVEMENT
UGWL	= UNDERGROUND WATER LINE	LPFGIS	= LINES PER FENDER GIS
OEEL	= OVERHEAD ELECTRIC LINE	CLF	= CHAIN LINK FENCE
UGEL	= UNDERGROUND ELECTRIC LINE	UGSL	= UNDERGROUND STORM LINE
WLS	= WOODSLINE	UGSL	= UNDERGROUND SANITARY LINE

S:\45760007\B0-Drawings\CS102\_1045760007.dwg, 8/8/2014 8:32:11 AM, rammore

REV. NO.	DESCRIPTIONS	DATE

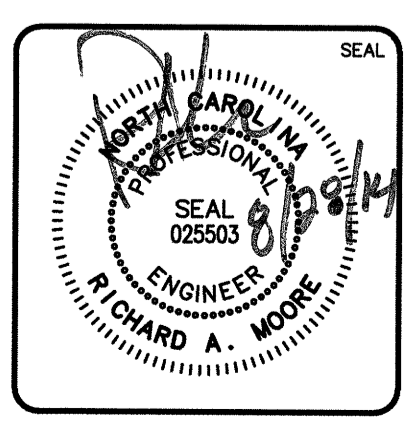
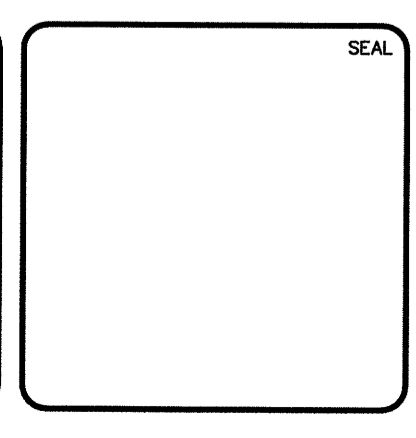

243 North Front Street  
Wilmington, North Carolina 28401  
Phone: (910)343-1048, Fax: (910)251-8282  
NCFIRM LIC. F-1222  
www.mckimcreed.com

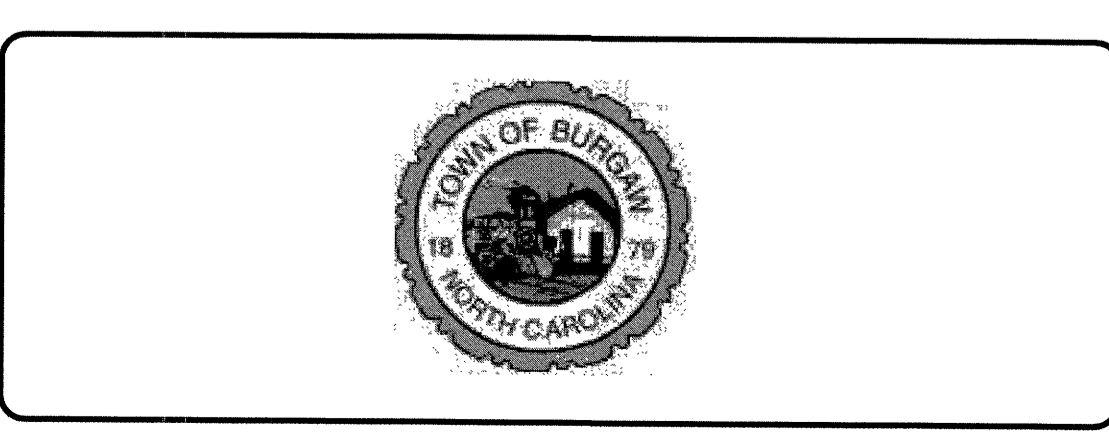

**Burgaw US 117/Walker Street**

---

**NC DOT ENCROACHMENT PLANS**

DATE:	MAY 2014	SCALE:	
MCE PROJ. #	45760007	HORIZONTAL:	N/A
DRAWN:	TCM	VERTICAL:	N/A
DESIGNED:	TCM		
CHECKED:	RAM		
PROJ. MGR.	RAM		

STATUS:	ISSUED FOR PERMITTING	REVISION:	
---------	-----------------------	-----------	--

SEE CS-103

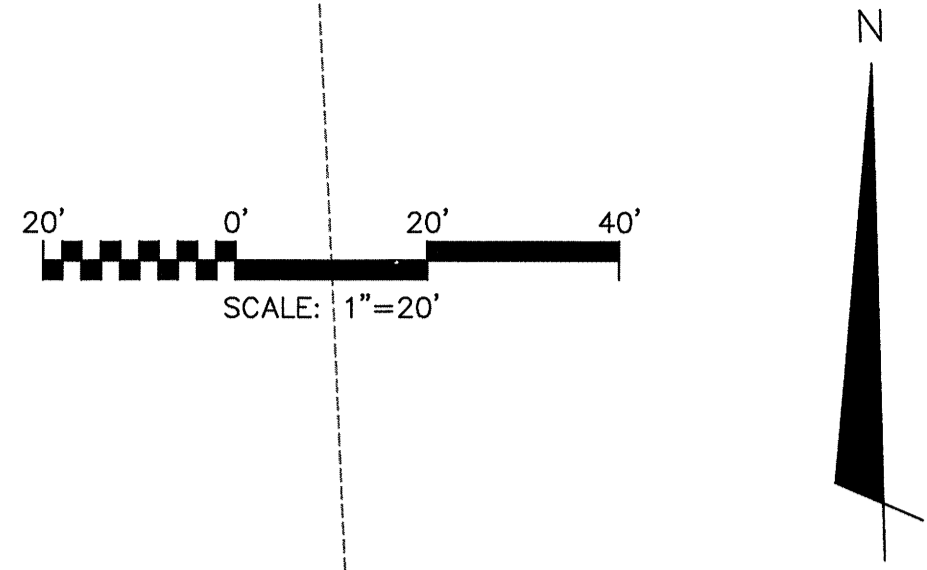
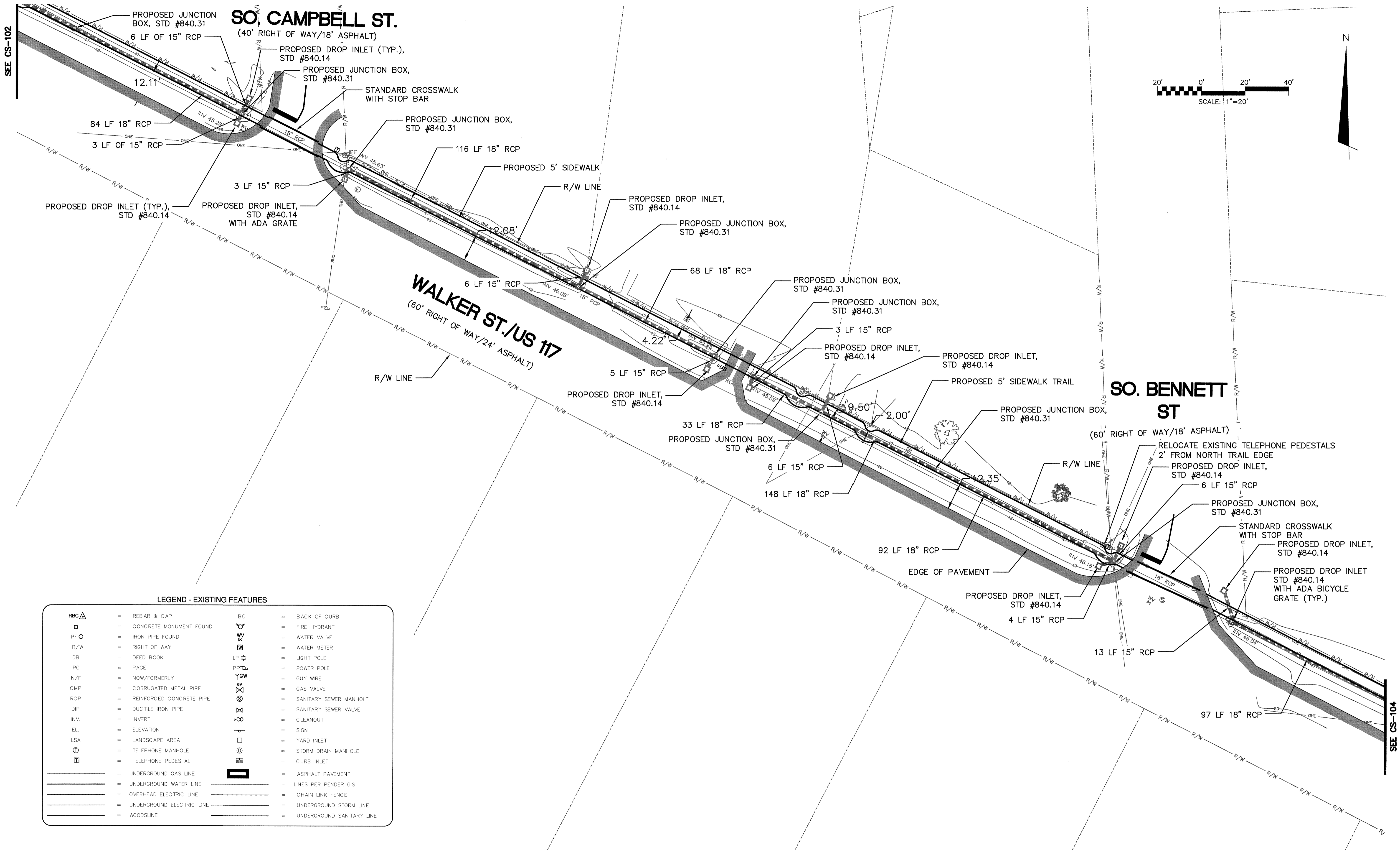

**LEGEND - EXISTING FEATURES**

RBC △	= REBAR & CAP	BC	= BACK OF CURB
□	= CONCRETE MONUMENT FOUND	FH	= FIRE HYDRANT
IPF ○	= IRON PIPE FOUND	WV	= WATER VALVE
R/W	= RIGHT OF WAY	WM	= WATER METER
DB	= DEED BOOK	LP	= LIGHT POLE
PG	= PAGE	PP	= POWER POLE
N/F	= NOW/FORMERLY	GW	= GUY WIRE
CMP	= CORRUGATED METAL PIPE	GV	= GAS VALVE
RCP	= REINFORCED CONCRETE PIPE	SSM	= SANITARY SEWER MANHOLE
DIP	= DUCTILE IRON PIPE	SSV	= SANITARY SEWER VALVE
INV.	= INVERT	CN	= CLEANOUT
EL.	= ELEVATION	S	= SIGN
LSA	= LANDSCAPE AREA	YI	= YARD INLET
⊙	= TELEPHONE MANHOLE	SDM	= STORM DRAIN MANHOLE
⊞	= TELEPHONE PEDESTAL	CI	= CURB INLET
—	= UNDERGROUND GAS LINE	AP	= ASPHALT PAVEMENT
—	= UNDERGROUND WATER LINE	LPFGIS	= LINES PER PENDER GIS
—	= OVERHEAD ELECTRIC LINE	CLF	= CHAIN LINK FENCE
—	= UNDERGROUND ELECTRIC LINE	USL	= UNDERGROUND STORM LINE
—	= WOODS LINE	USL	= UNDERGROUND SANITARY LINE

REVNO.	DESCRIPTIONS	DATE

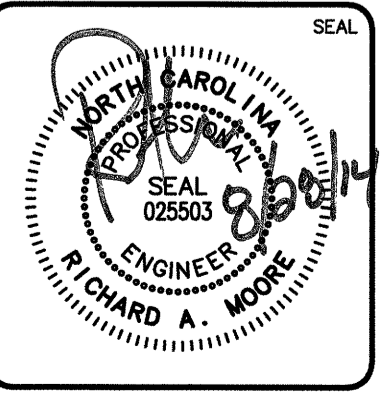
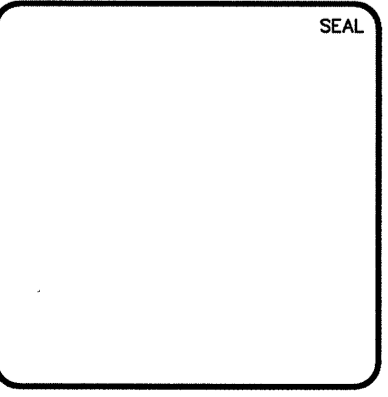

**MCKIM & CREED**  
 243 North Front Street  
 Wilmington, North Carolina 28401  
 Phone: (910)343-1048, Fax: (910)251-8282  
 NCFIRM Lic. F-1222  
 www.mckimcreed.com

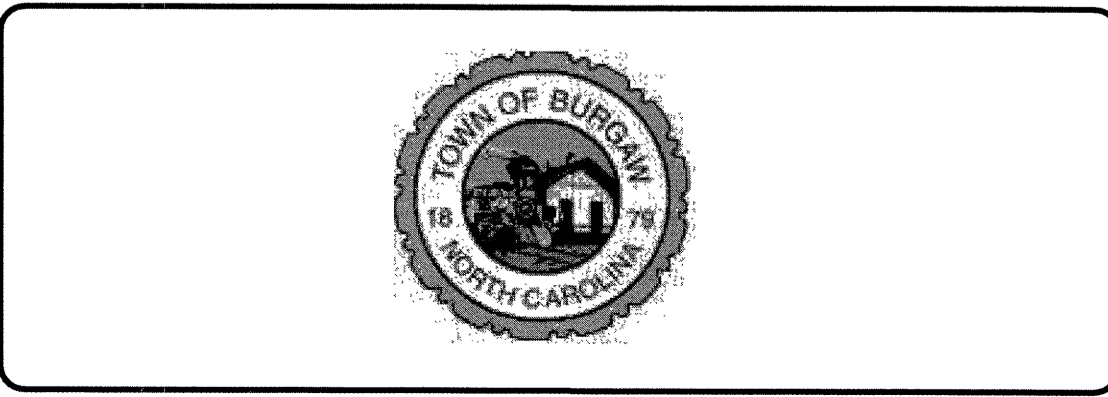

**Burgaw US 117/Walker Street**

---

**NC DOT ENCROACHMENT PLANS**

DATE:	MAY 2014	SCALE:		M&C FILE NUMBER:	CS103
MCE PROJ. #:	45760007	HORIZONTAL:	N/A	DRAWING NUMBER:	
DRAWN:	TCM	VERTICAL:	N/A	REVISION:	3
DESIGNED:	TCM				
CHECKED:	RAM				
PROJ. MGR.:	RAM				

STATUS: ISSUED FOR PERMITTING

S:\4270007190-Drawings\CS103\_045760007.dwg, 01/18/2014 9:05:16 AM, vromano

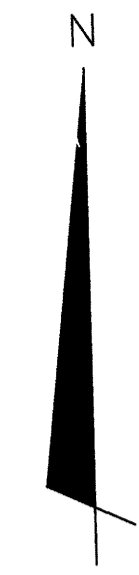
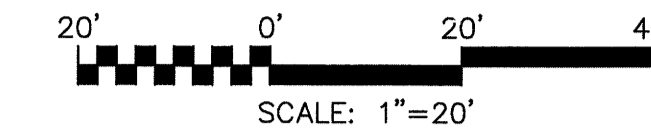

NOTE: FIELD ADJUSTMENT TO LOCATIONS SHOWN FOR DROP INLETS ARE PERMISSIBLE TO ALLOW INSTALLATION IN LOW SPOTS FOR DRAINAGE.

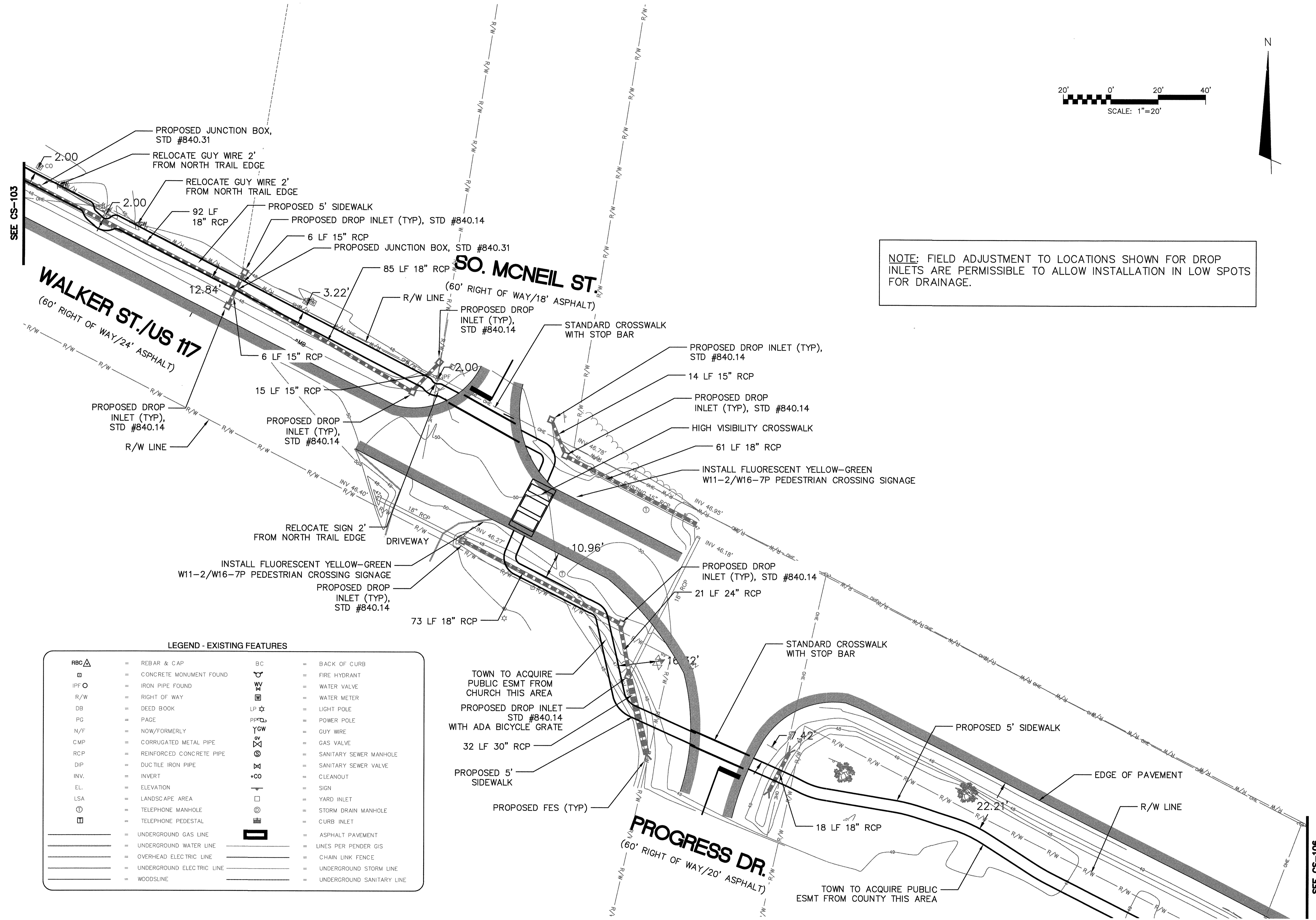

LEGEND - EXISTING FEATURES

RBC Δ	= REBAR & CAP	BC	= BACK OF CURB
□	= CONCRETE MONUMENT FOUND	FH	= FIRE HYDRANT
IPF ○	= IRON PIPE FOUND	WV	= WATER VALVE
R/W	= RIGHT OF WAY	WM	= WATER METER
DB	= DEED BOOK	LP *	= LIGHT POLE
PG	= PAGE	PP *	= POWER POLE
N/F	= NOW/FORMERLY	YGW	= GUY WIRE
CMP	= CORRUGATED METAL PIPE	GV	= GAS VALVE
RCP	= REINFORCED CONCRETE PIPE	SSM	= SANITARY SEWER MANHOLE
DIP	= DUCTILE IRON PIPE	SSV	= SANITARY SEWER VALVE
INV.	= INVERT	CN	= CLEANOUT
EL.	= ELEVATION	S	= SIGN
LSA	= LANDSCAPE AREA	YI	= YARD INLET
⊙	= TELEPHONE MANHOLE	SDM	= STORM DRAIN MANHOLE
⊞	= TELEPHONE PEDESTAL	CI	= CURB INLET
—	= UNDERGROUND GAS LINE	AP	= ASPHALT PAVEMENT
—	= UNDERGROUND WATER LINE	LP	= LINES PER PENDER GIS
—	= OVERHEAD ELECTRIC LINE	CLF	= CHAIN LINK FENCE
—	= UNDERGROUND ELECTRIC LINE	UGSL	= UNDERGROUND STORM LINE
—	= WOODSLINE	UGSL	= UNDERGROUND SANITARY LINE

S:\45760007\85-Drawing\CS104\_04576007.dwg, 01/02/2014 9:54:20 AM, ramono

REVNO.	DESCRIPTIONS	DATE

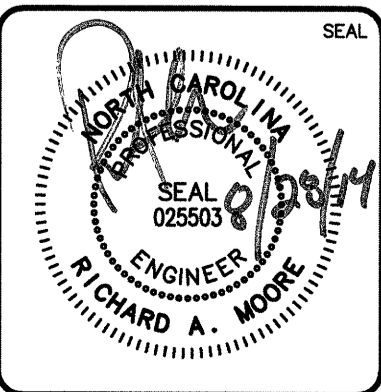
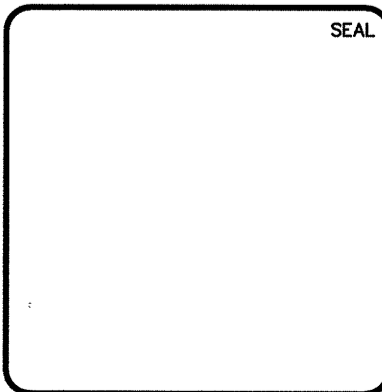

**MCKIM & CREED**  
 243 North Front Street  
 Wilmington, North Carolina 28401  
 Phone: (910)343-1048, Fax: (910)251-8282  
 NCFIRM LIC. F-1222  
 www.mckimcreed.com

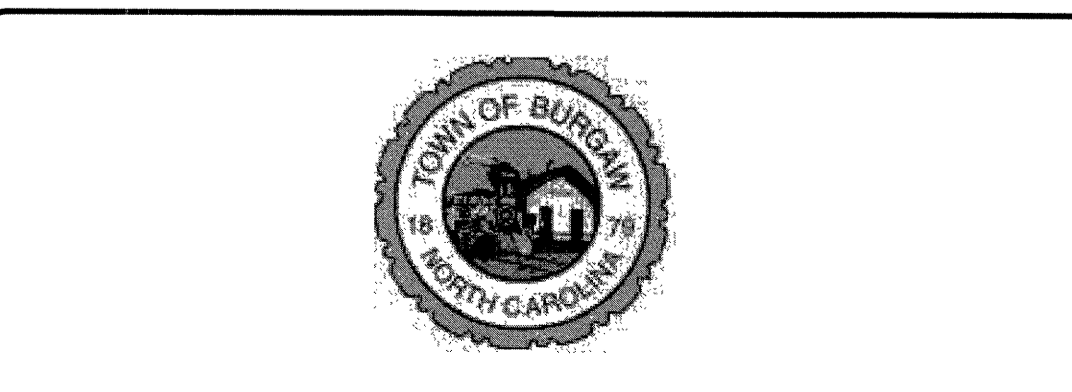

**Burgaw US 117/Walker Street**  
**NC DOT ENCROACHMENT PLANS**

DATE:	MAY 2014	SCALE:	1"=20'	MAC FILE NUMBER:	CS104
MCE PROJ. #	45760007	HORIZONTAL:	N/A	DRAWING NUMBER:	4
DRAWN:	TCM	VERTICAL:	N/A		
DESIGNED:	TCM				
CHECKED:	RAM				
PROJ. MGR.	RAM				
STATUS:	ISSUED FOR PERMITTING				

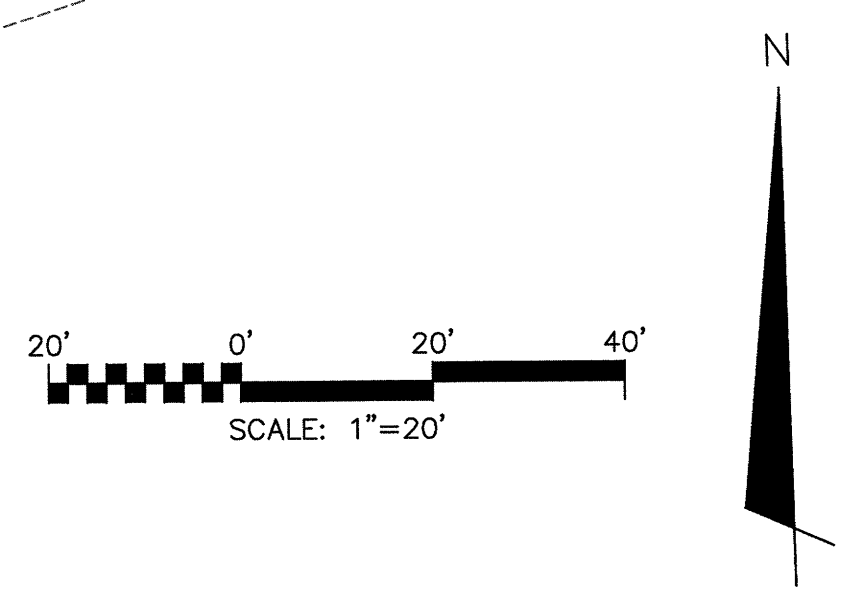
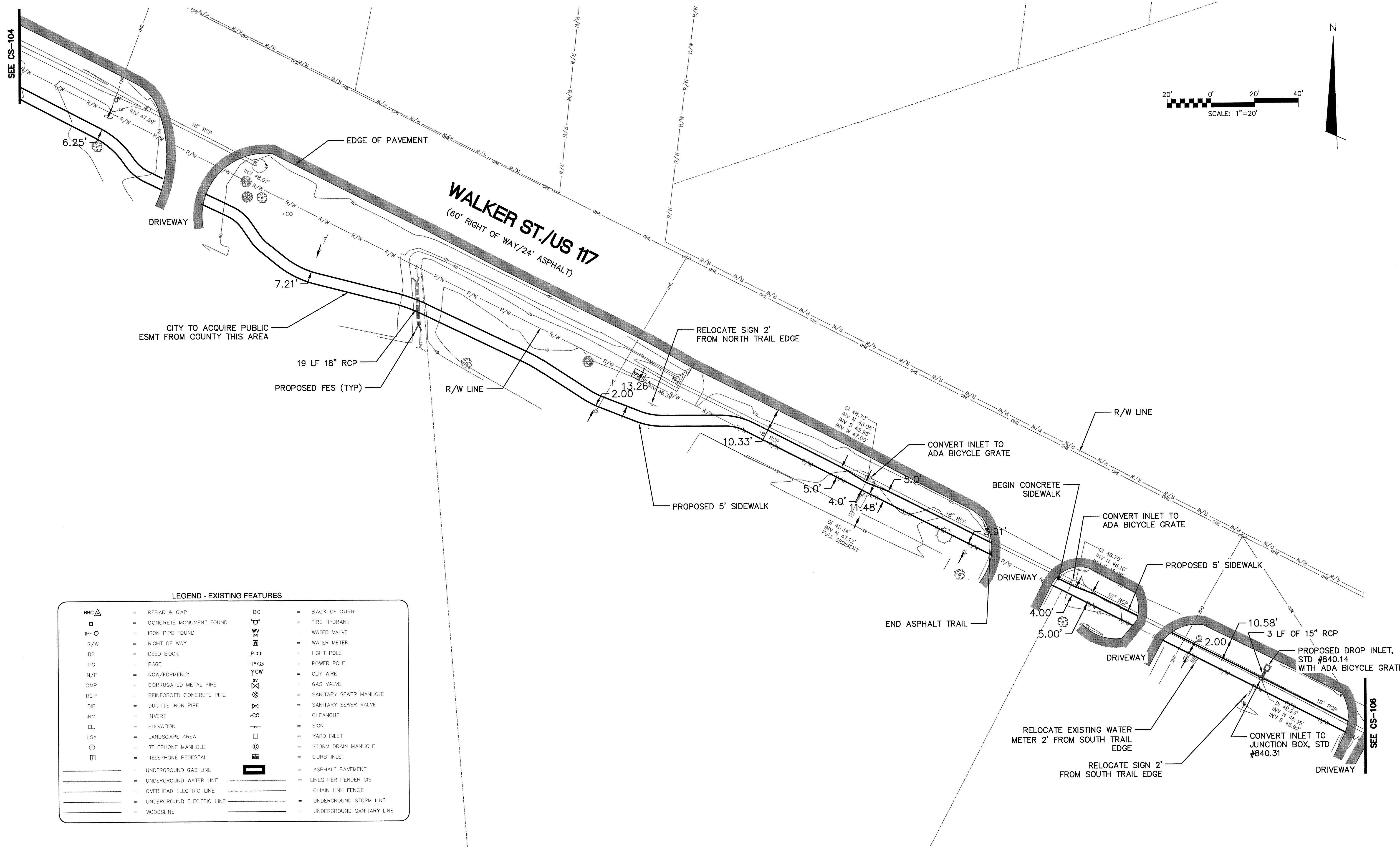

CITY TO ACQUIRE PUBLIC ESMT FROM COUNTY THIS AREA

DRIVEWAY

19 LF 18" RCP

PROPOSED FES (TYP)

# WALKER ST./US 117

(60' RIGHT OF WAY/24' ASPHALT)

RELOCATE SIGN 2' FROM NORTH TRAIL EDGE

PROPOSED 5' SIDEWALK

CONVERT INLET TO ADA BICYCLE GRATE

BEGIN CONCRETE SIDEWALK

CONVERT INLET TO ADA BICYCLE GRATE

PROPOSED 5' SIDEWALK

END ASPHALT TRAIL

DRIVEWAY

3 LF OF 15" RCP

PROPOSED DROP INLET, STD #840.14 WITH ADA BICYCLE GRATE

RELOCATE EXISTING WATER METER 2' FROM SOUTH TRAIL EDGE

RELOCATE SIGN 2' FROM SOUTH TRAIL EDGE

CONVERT INLET TO JUNCTION BOX, STD #840.31

DRIVEWAY

**LEGEND - EXISTING FEATURES**

RBC Δ	= REBAR & CAP	BC	= BACK OF CURB
□	= CONCRETE MONUMENT FOUND	⊕	= FIRE HYDRANT
IPF ○	= IRON PIPE FOUND	⊕	= WATER VALVE
R/W	= RIGHT OF WAY	⊕	= WATER METER
DB	= DEED BOOK	LP ⊕	= LIGHT POLE
PG	= PAGE	PP ⊕	= POWER POLE
N/F	= NOW/FORMERLY	⊕	= GUY WIRE
CMP	= CORRUGATED METAL PIPE	⊕	= GAS VALVE
RCP	= REINFORCED CONCRETE PIPE	⊕	= SANITARY SEWER MANHOLE
DIP	= DUCTILE IRON PIPE	⊕	= SANITARY SEWER VALVE
INV.	= INVERT	⊕	= CLEANOUT
EL.	= ELEVATION	⊕	= SIGN
LSA	= LANDSCAPE AREA	⊕	= YARD INLET
⊕	= TELEPHONE MANHOLE	⊕	= STORM DRAIN MANHOLE
⊕	= TELEPHONE PEDESTAL	⊕	= CURB INLET
—	= UNDERGROUND GAS LINE	⊕	= ASPHALT PAVEMENT
—	= UNDERGROUND WATER LINE	⊕	= LINES PER PENDER GIS
—	= OVERHEAD ELECTRIC LINE	—	= CHAIN LINK FENCE
—	= UNDERGROUND ELECTRIC LINE	—	= UNDERGROUND STORM LINE
—	= WOODS LINE	—	= UNDERGROUND SANITARY LINE

SEE CS-106

REVNO.	DESCRIPTIONS	DATE

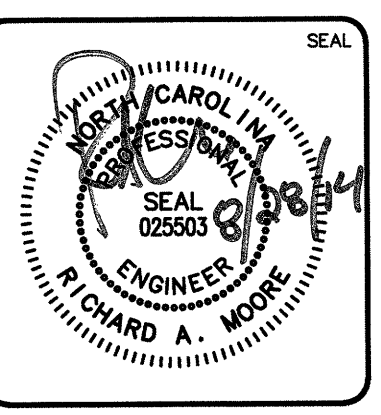
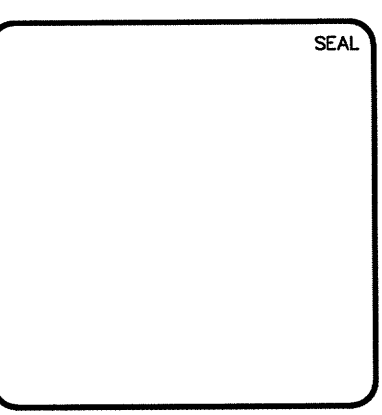

**MCKIM & CREED**

243 North Front Street  
 Wilmington, North Carolina 28401  
 Phone: (910)343-1048, Fax: (910)251-8282  
 NCFIRM LIC. F-1222  
 www.mckimcreed.com

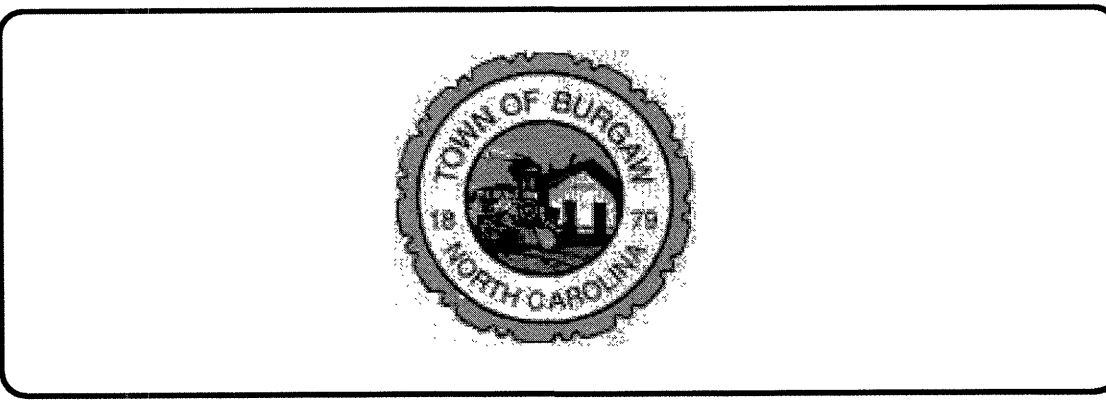

**Burgaw US 117/Walker Street**

---

**NC DOT ENCROACHMENT PLANS**

DATE: MAY 2014	SCALE: HORIZONTAL: N/A	MAC FILE NUMBER: CS105
MCE PROJ. # 45760007	VERTICAL: N/A	DRAWING NUMBER: 5
DRAWN: TCM		
DESIGNED: TCM		
CHECKED: RAM		
PROJ. MGR.: RAM		
STATUS: ISSUED FOR PERMITTING		

SEE CS-105

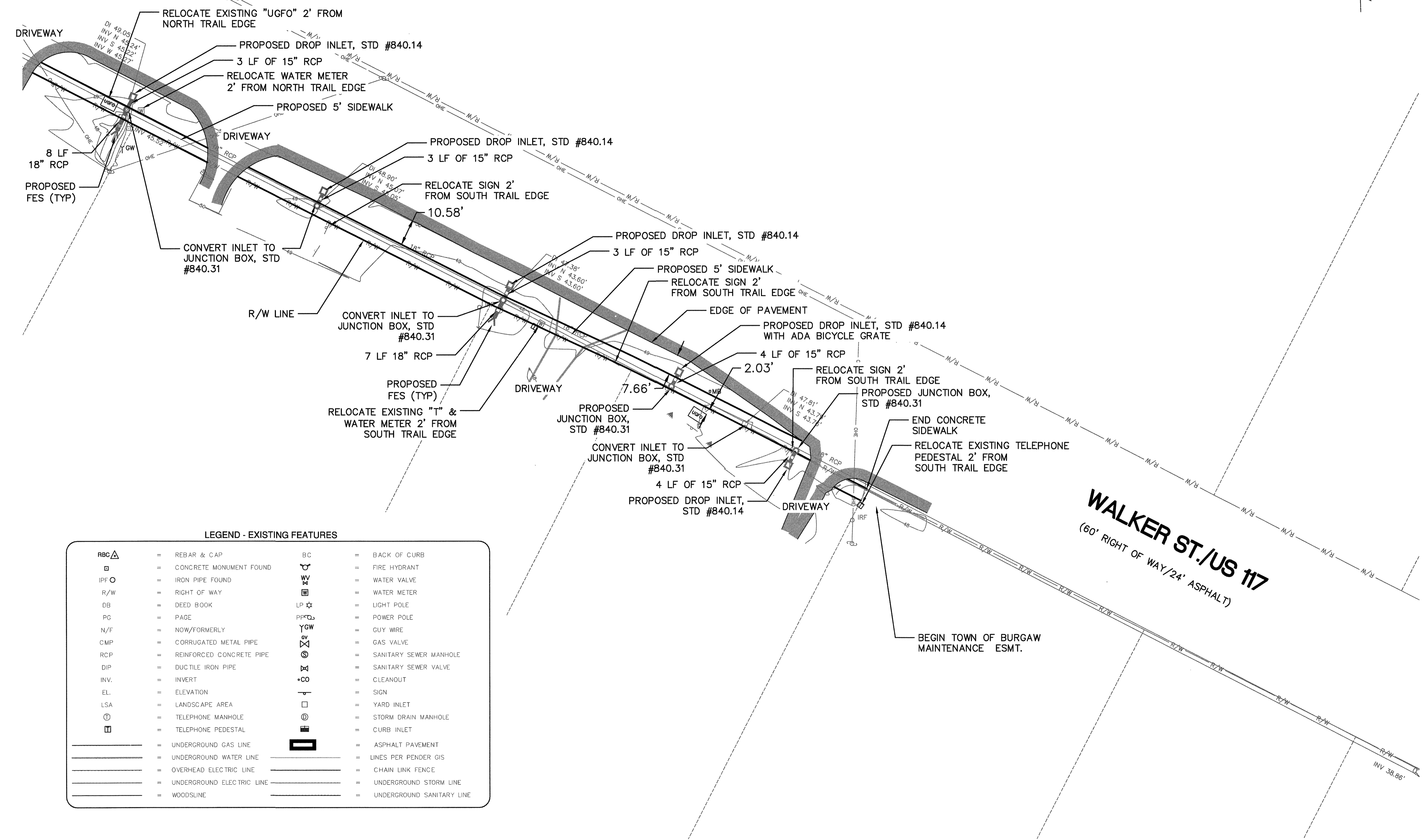
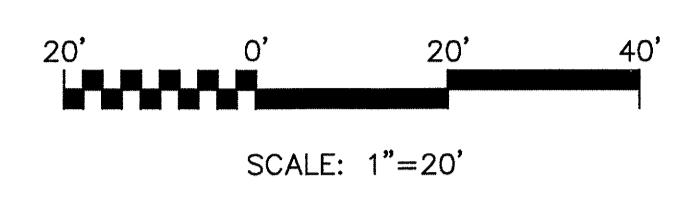

LEGEND - EXISTING FEATURES

RBC $\Delta$	= REBAR & CAP	BC	= BACK OF CURB
$\square$	= CONCRETE MONUMENT FOUND	$\odot$	= FIRE HYDRANT
IPF $\circ$	= IRON PIPE FOUND	$\square$	= WATER METER
R/W	= RIGHT OF WAY	LP $\star$	= LIGHT POLE
DB	= DEED BOOK	PERD $\square$	= POWER POLE
PG	= PAGE	GW	= GUY WIRE
N/F	= NOW/FORMERLY	$\square$	= GAS VALVE
CMP	= CORRUGATED METAL PIPE	$\square$	= SANITARY SEWER MANHOLE
RCP	= REINFORCED CONCRETE PIPE	$\square$	= SANITARY SEWER VALVE
DIP	= DUCTILE IRON PIPE	$\square$	= CLEANOUT
INV.	= INVERT	$\square$	= SIGN
EL.	= ELEVATION	$\square$	= YARD INLET
LSA	= LANDSCAPE AREA	$\square$	= STORM DRAIN MANHOLE
$\square$	= TELEPHONE MANHOLE	$\square$	= CURB INLET
$\square$	= TELEPHONE PEDESTAL	$\square$	= ASPHALT PAVEMENT
$\square$	= UNDERGROUND GAS LINE	$\square$	= LINES PER PENDER GIS
$\square$	= UNDERGROUND WATER LINE	$\square$	= CHAIN LINK FENCE
$\square$	= OVERHEAD ELECTRIC LINE	$\square$	= UNDERGROUND STORM LINE
$\square$	= UNDERGROUND ELECTRIC LINE	$\square$	= UNDERGROUND SANITARY LINE
$\square$	= WOODSLINE		

S:\CADD\107070\107070.dwg, 04/15/2014 12:47:58 PM, rmmora

REVNO.	DESCRIPTIONS	DATE

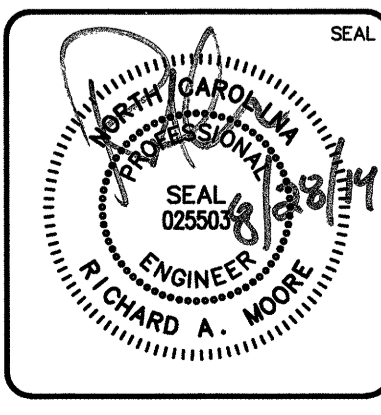
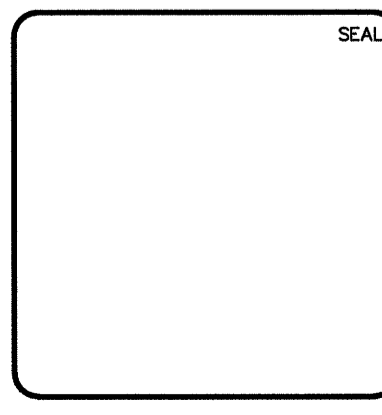

**MCKIM & CREED**  
 243 North Front Street  
 Wilmington, North Carolina 28401  
 Phone: (910)343-1048, Fax: (910)251-8282  
 NCFIRM Lic. F-1222  
 www.mckimcreed.com

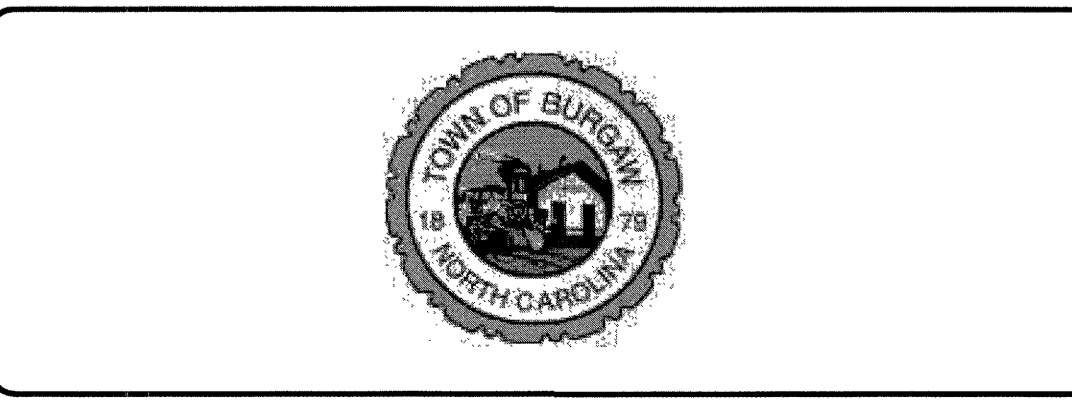

Burgaw US 117/Walker Street

NC DOT ENCROACHMENT PLANS

DATE:	MAY 2014
MCE PROJ. #	45780007
DRAWN	TCM
DESIGNED	TCM
CHECKED	RAM
PROJ. MGR.	RAM

SCALE:	
HORIZONTAL:	N/A
VERTICAL:	N/A

MAC FILE NUMBER	CS106
DRAWING NUMBER	6

STATUS: ISSUED FOR PERMITTING

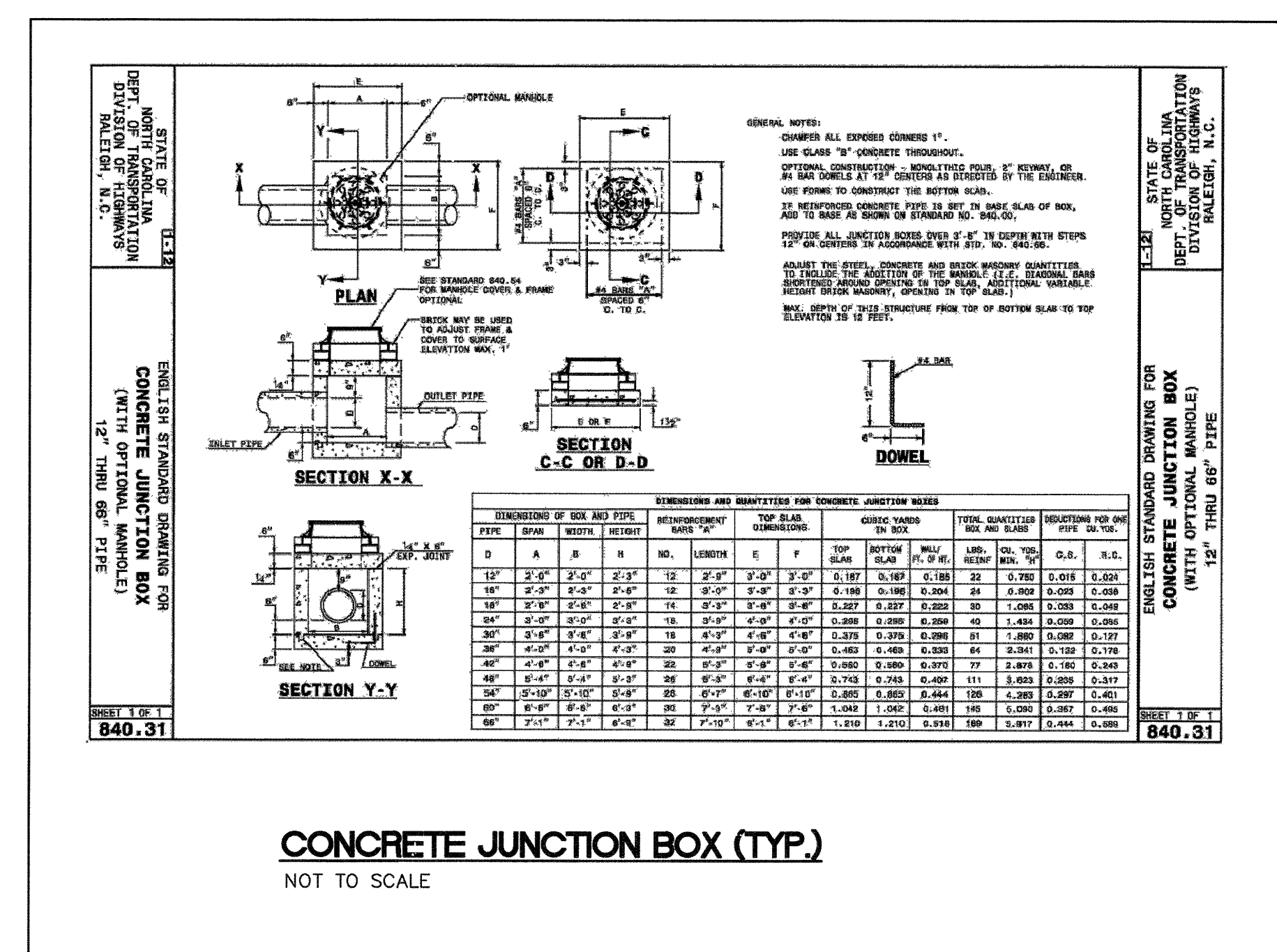
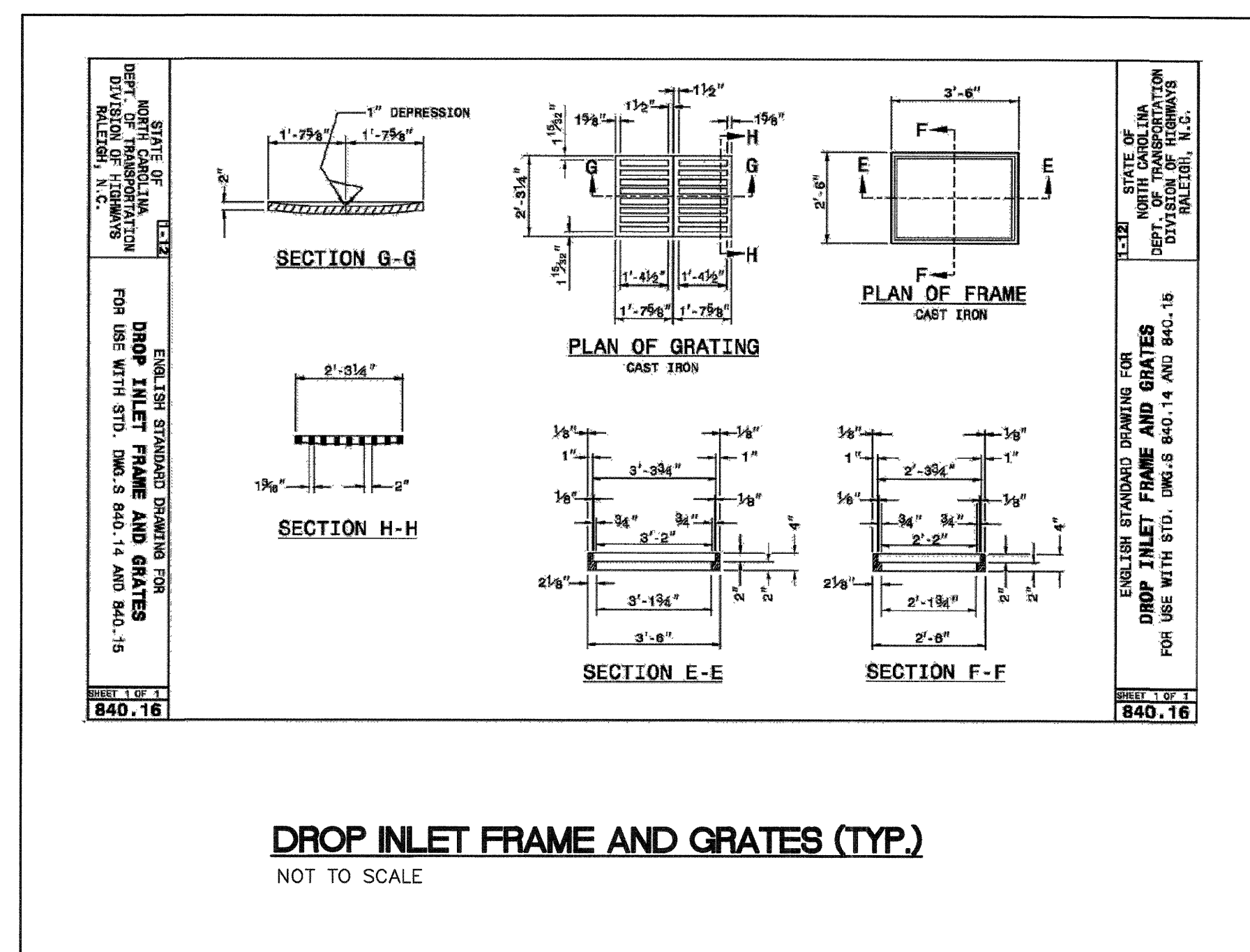
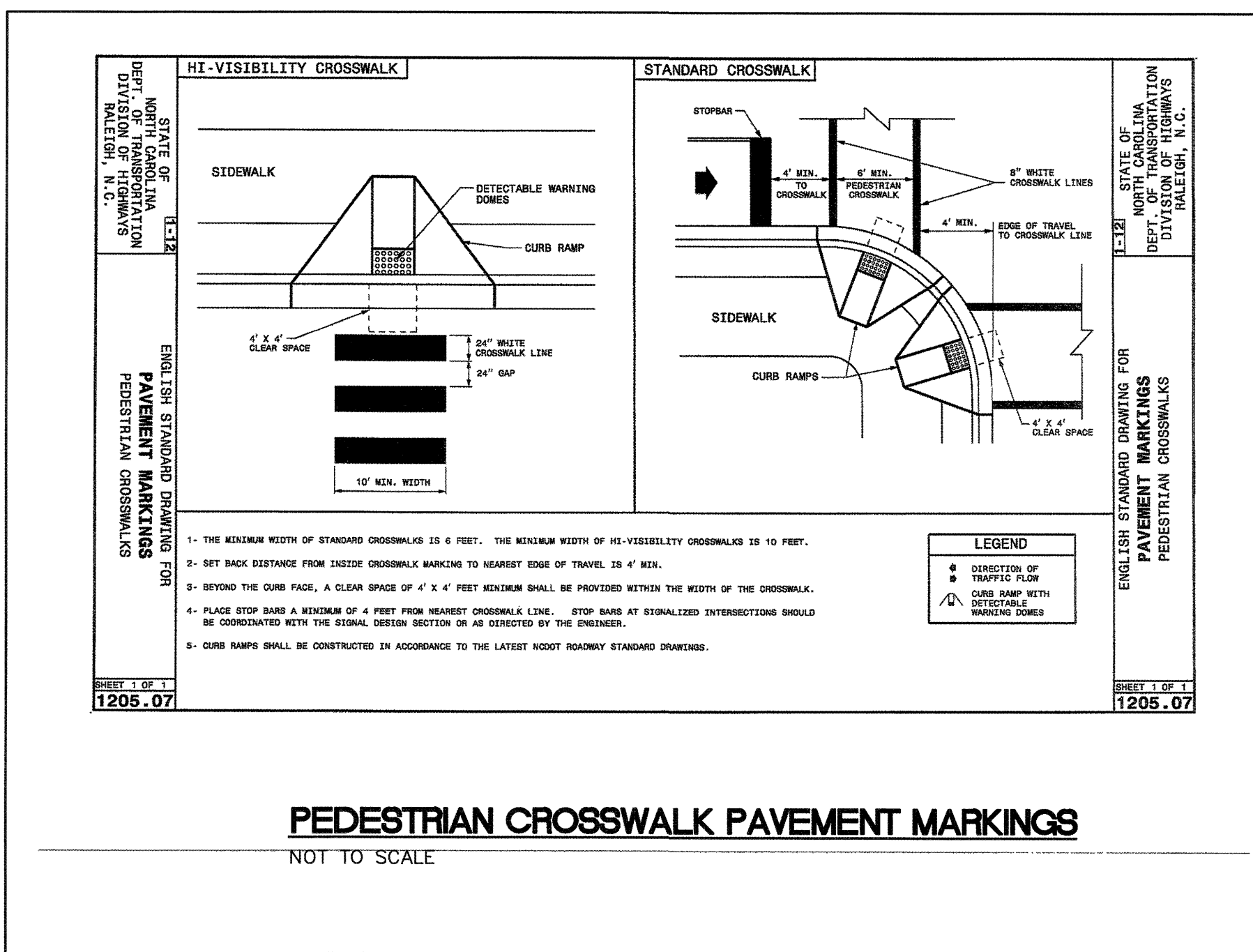
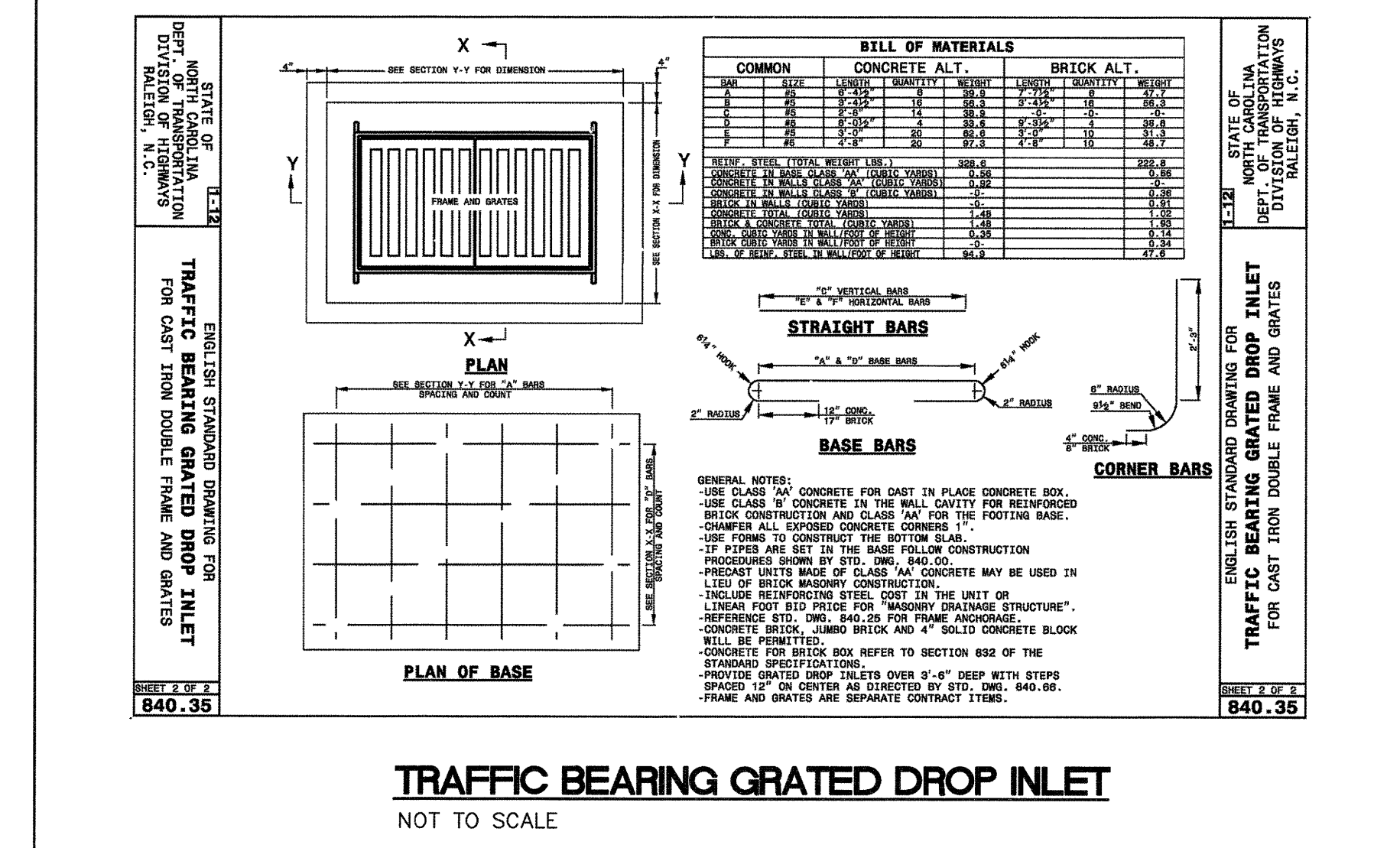
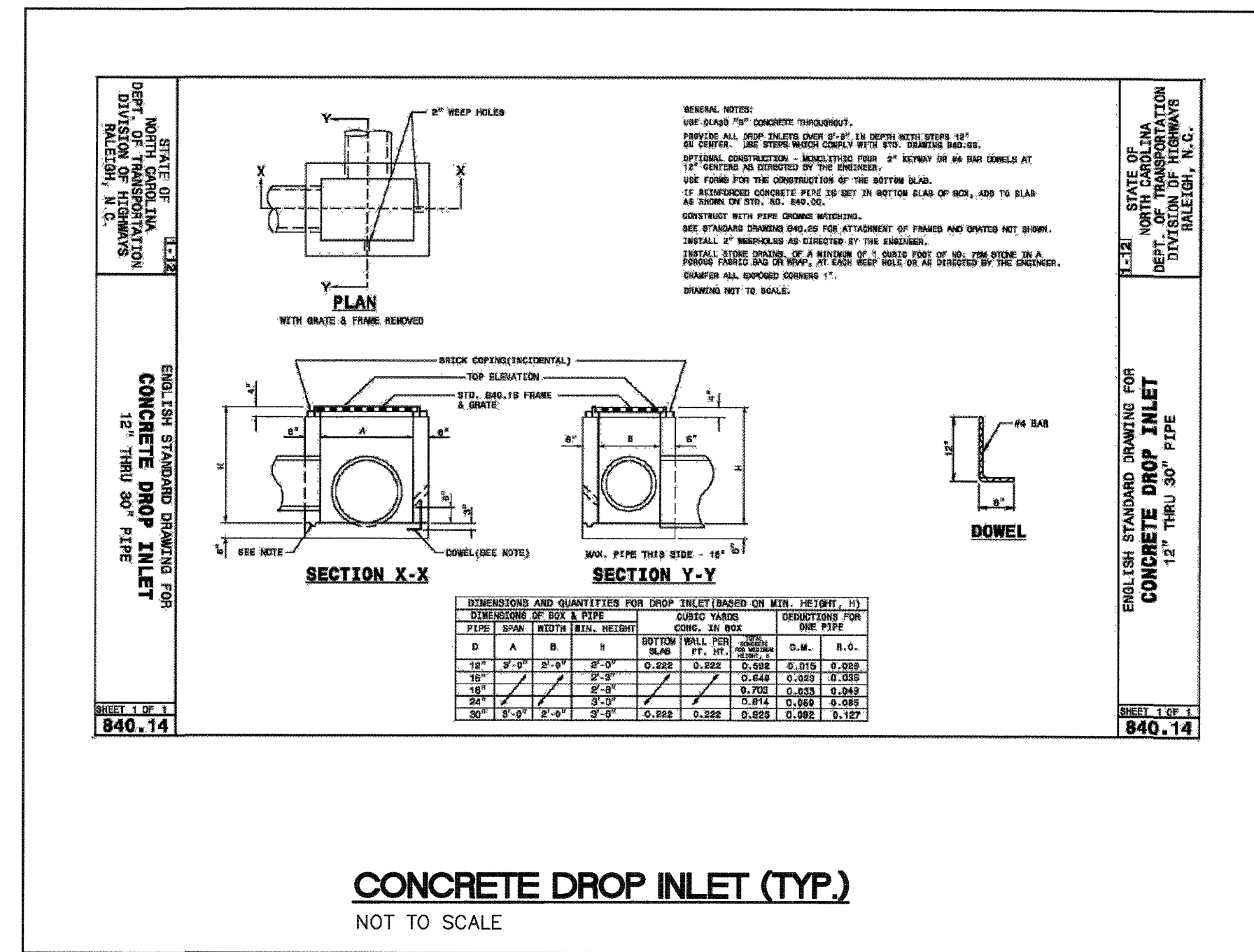
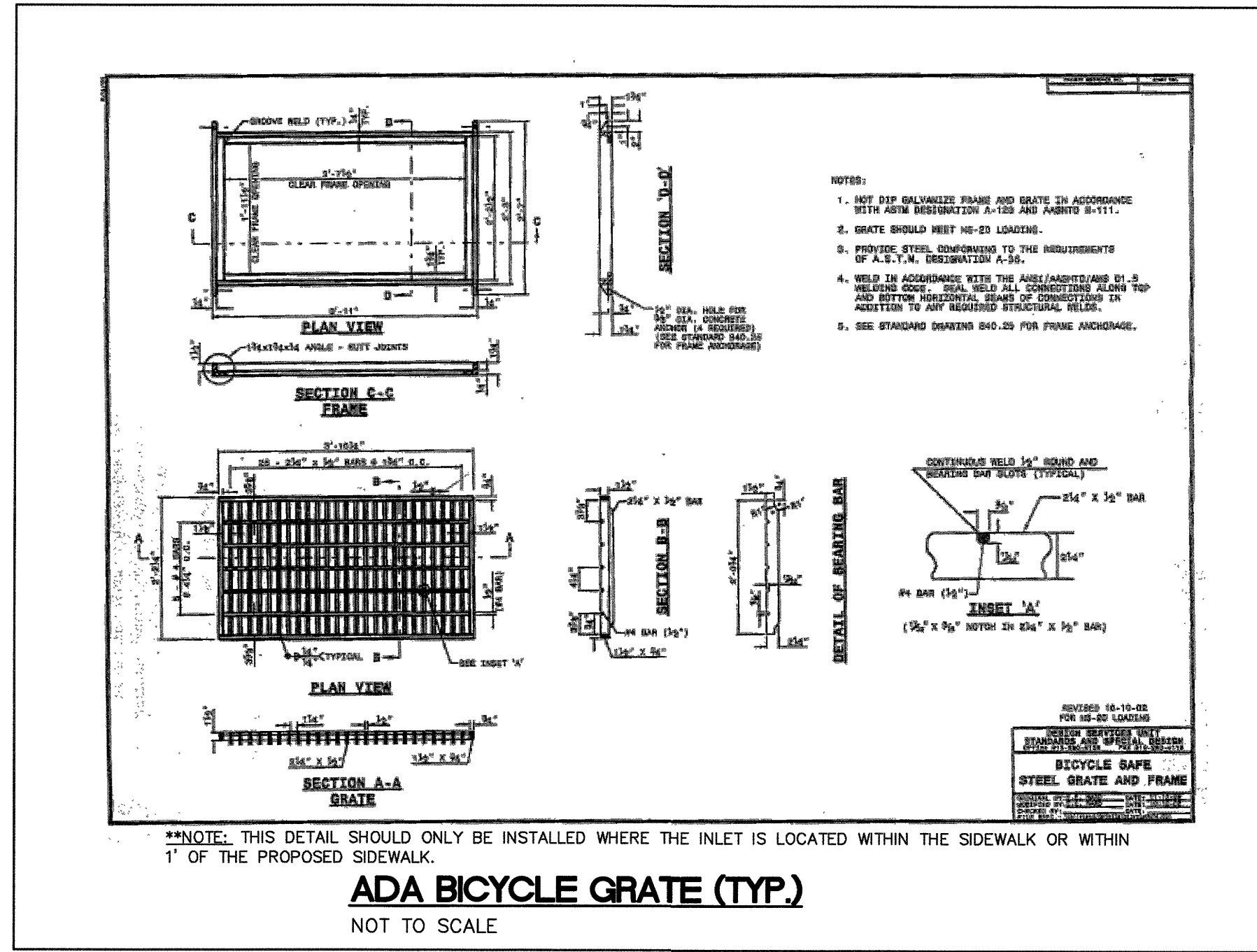
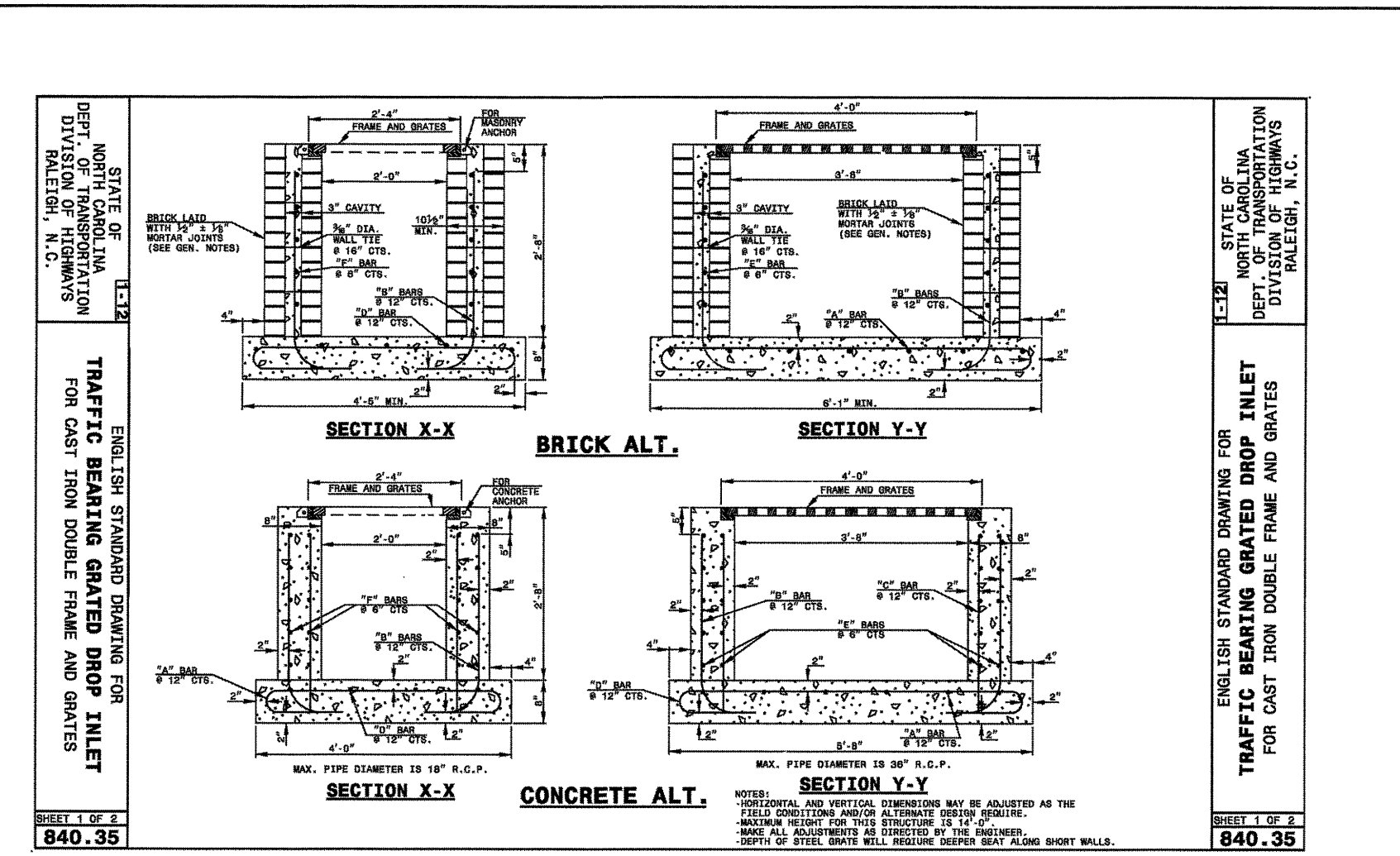
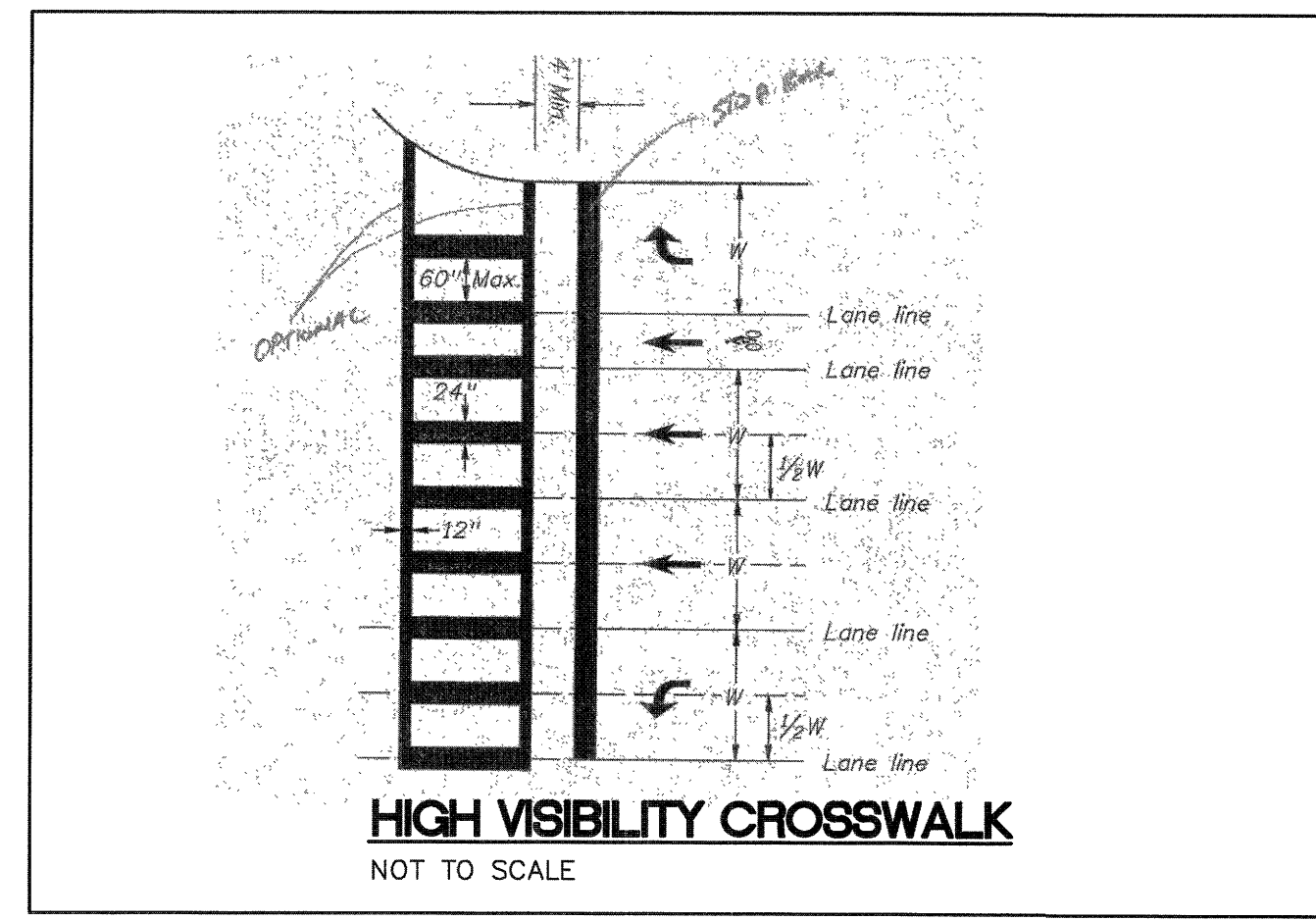
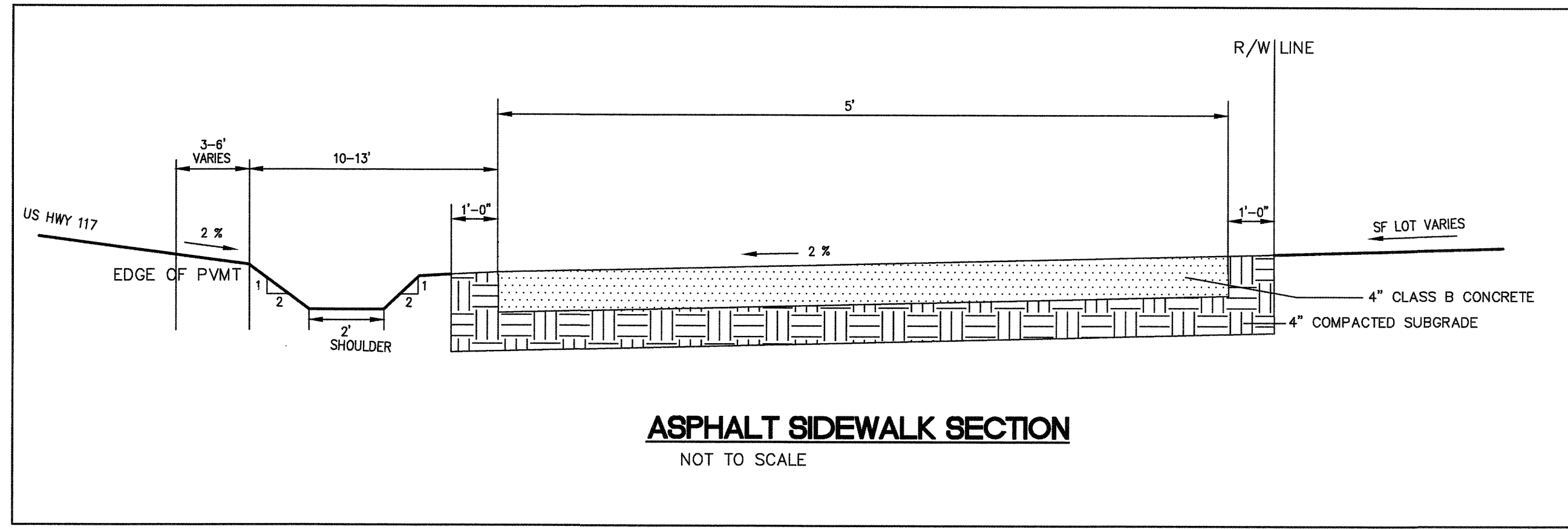

S:\4576\0007\66-Drawings\CT501\_045760007.dwg, 8/28/2014 12:14:46 PM, RAM000

REVNO.	DESCRIPTIONS	DATE

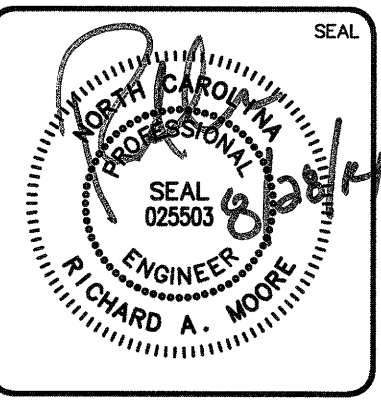
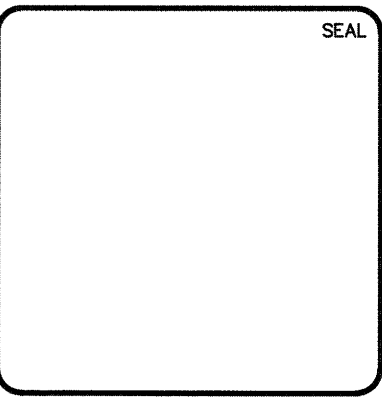

**MCKIM & CREED**  
243 North Front Street  
Wilmington, North Carolina 28401  
Phone: (910)343-1048, Fax: (910)251-8282  
NC FIRM LIC. F-1222  
www.mckimcreed.com

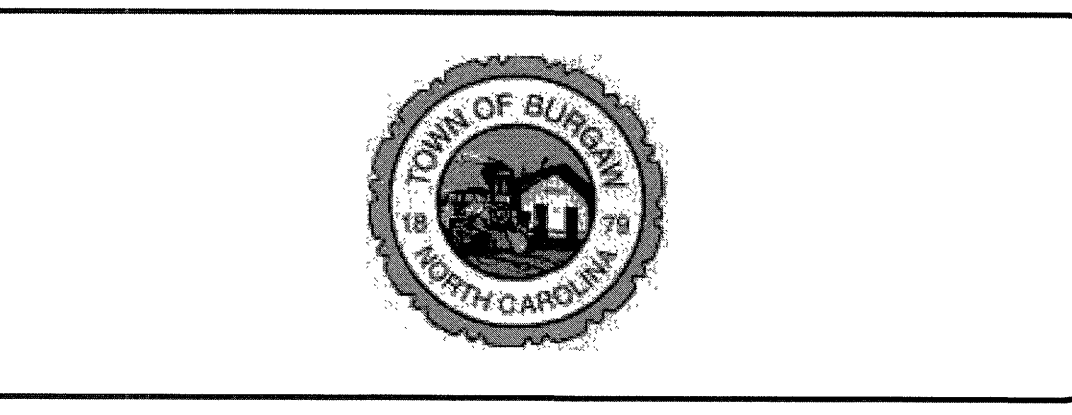

Burgaw US 117/Walker Street  
NC DOT ENCROACHMENT PLANS

DATE: MAY 2014  
MCE PROJ. # 45760007  
DRAWN: TCM  
DESIGNED: TCM  
CHECKED: RAM  
PROJ. MGR.: RAM

SCALE: HORIZONTAL: N/A  
VERTICAL: N/A

MAC FILE NUMBER: CT501  
DRAWING NUMBER: 7  
REVISION: 1

STATUS: ISSUED FOR PERMITTING