

**Project Special Provisions**  
*(Version 12.2)*  
**Signals and Intelligent Transportation Systems**

Prepared By: \_\_\_\_\_  
16-Jul-13

**Contents**

**1. 2012 STANDARD SPECIFICATIONS FOR ROADS & STRUCTURES .....5**

1.1. POLYMER CONCRETE (PC) JUNCTION BOXES (1091-5(B)).....5

1.2. JUNCTION BOXES (1098-5).....5

1.3. CONTROLLERS WITH CABINETS – MATERIAL (1751-2) .....5

1.4. PEDESTALS (1743).....5

**2. SIGNAL HEADS.....6**

2.1. MATERIALS .....6

A. General:.....6

B. Vehicle Signal Heads: .....8

C. Pedestrian Signal Heads: .....10

D. Signal Cable: .....12

E. Optically-Programmed Vehicle Signal Sections: .....12

F. Louvers:.....13

**3. VIDEO IMAGING LOOP EMULATOR DETECTOR SYSTEMS .....13**

3.1. DESCRIPTION .....13

3.2. MATERIALS .....13

A. General:.....13

B. Loop Emulator System: .....15

C. Video Imaging Loop Emulator System Support: .....16

3.3. CONSTRUCTION METHODS.....16

3.4. MEASUREMENT AND PAYMENT .....17

**4. MICROWAVE VEHICLE DETECTOR .....17**

4.1. DESCRIPTION .....17

4.2. MATERIALS .....18

4.3. CONSTRUCTION METHODS.....18

4.4. MEASUREMENT AND PAYMENT .....18

**5. TWISTED-PAIR COMMUNICATIONS CABLE.....18**

5.1. DESCRIPTION .....18

5.2. MATERIALS .....19

A. General:.....19

B. Communications Cable: .....19

C. Communications Cable Identification Markers (Cable Wraps):.....19

5.3. CONSTRUCTION METHODS.....20

A. General:.....20

B. Aerial Installation: .....20

C. Underground Installation: .....21

D. Bonding and Splicing: .....22

E. Cable Identification Markers:.....22

|            |  |           |
|------------|--|-----------|
| 5.4.       | MEASUREMENT AND PAYMENT .....                                | 22        |
| <b>6.</b>  | <b>COMMUNICATIONS SYSTEM SUPPORT EQUIPMENT .....</b>         | <b>22</b> |
| 6.1.       | DESCRIPTION .....  | 22        |
| 6.2.       | MATERIALS .....  | 22        |
| A.         | <i>General:</i> .....  | 22        |
| B.         | <i>Fiber-Optic Support Equipment</i> .....                   | 23        |
| C.         | <i>Wireless Radio Support Equipment</i> .....                | 24        |
| 6.3.       | MEASUREMENT AND PAYMENT .....                                | 25        |
| <b>7.</b>  | <b>FIBER-OPTIC TRAINING .....</b>                            | <b>25</b> |
| 7.1.       | DESCRIPTION .....  | 25        |
| 7.2.       | MATERIALS .....  | 25        |
| 7.3.       | MEASUREMENT AND PAYMENT .....                                | 27        |
| <b>8.</b>  | <b>SPLICE CABINET (FIBER OPTICS) .....</b>                   | <b>27</b> |
| 8.1.       | DESCRIPTION .....  | 27        |
| 8.2.       | MATERIALS .....  | 27        |
| 8.3.       | CONSTRUCTION METHODS .....                                   | 27        |
| A.         | <i>General:</i> .....  | 27        |
| B.         | <i>Pole Mounted:</i> .....                                   | 27        |
| C.         | <i>Base Mounted:</i> .....                                   | 28        |
| 8.4.       | MEASUREMENT AND PAYMENT .....                                | 28        |
| <b>9.</b>  | <b>SOLAR POWER, 900 MHZ SPREAD SPECTRUM RADIO .....</b>      | <b>28</b> |
| 9.1.       | DESCRIPTION .....  | 28        |
| 9.2.       | MATERIALS .....  | 28        |
| A.         | <i>900MHz Wireless Radio System:</i> .....                   | 28        |
| B.         | <i>Solar Powered Assembly:</i> .....                         | 29        |
| 9.3.       | CONSTRUCTION METHODS .....                                   | 31        |
| A.         | <i>Antenna Mounting:</i> .....                               | 31        |
| B.         | <i>Solar Power Assembly:</i> .....                           | 32        |
| 9.4.       | MEASUREMENT AND PAYMENT .....                                | 33        |
| <b>10.</b> | <b>MODIFY SPREAD SPECTRUM WIRELESS RADIO.....</b>            | <b>33</b> |
| 10.1.      | DESCRIPTION .....  | 33        |
| 10.2.      | MATERIALS .....  | 33        |
| 10.3.      | CONSTRUCTION METHODS .....                                   | 33        |
| 10.4.      | MEASUREMENT AND PAYMENT .....                                | 34        |
| <b>11.</b> | <b>TRAFFIC SIGNAL SUPPORTS .....</b>                         | <b>34</b> |
| 11.1.      | METAL TRAFFIC SIGNAL SUPPORTS – ALL POLES .....              | 34        |
| A.         | <i>General:</i> .....  | 34        |
| B.         | <i>Materials:</i> .....                                      | 36        |
| C.         | <i>Construction Methods:</i> .....                           | 37        |
| 11.2.      | METAL STRAIN POLE.....                                       | 38        |
| A.         | <i>Materials:</i> .....                                      | 38        |
| B.         | <i>Construction Methods:</i> .....                           | 40        |
| 11.3.      | METAL POLE WITH MAST ARM.....                                | 40        |
| A.         | <i>Materials:</i> .....                                      | 41        |
| B.         | <i>Construction Methods:</i> .....                           | 41        |
| 11.4.      | DRILLED PIER FOUNDATIONS FOR METAL TRAFFIC SIGNAL POLES..... | 41        |
| A.         | <i>Description:</i> .....                                    | 42        |
| B.         | <i>Soil Test and Foundation Determination:</i> .....         | 42        |
| C.         | <i>Drilled Pier Construction:</i> .....                      | 44        |
| 11.5.      | CUSTOM DESIGN OF TRAFFIC SIGNAL SUPPORTS .....               | 44        |
| A.         | <i>General:</i> .....  | 44        |
| B.         | <i>Metal Poles:</i> .....                                    | 45        |

**TIP Number**  
**Signals & Intelligent Transportation Systems**

**County Name**

|   |           |
|---|-----------|
| C. Mast Arms: .....   | 48        |
| 11.6. PROTECTIVE POWDER COATING FOR METAL POLES .....       | 48        |
| A. Description: .....                                       | 48        |
| B. Materials: .....   | 48        |
| C. Powder Coating Shop Approval: .....                      | 48        |
| D. Construction Methods: .....                              | 49        |
| 11.7. METAL SIGNAL POLE REMOVALS .....                      | 51        |
| A. Description: .....                                       | 51        |
| B. Construction Methods: .....                              | 51        |
| 11.8. POLE NUMBERING SYSTEM .....                           | 51        |
| A. New Poles .....  | 51        |
| B. Reused Poles .....                                       | 51        |
| 11.9. REUSED POLE SHAFTS AND/OR MAST ARMS .....             | 52        |
| 11.10. MEASUREMENT AND PAYMENT .....                        | 52        |
| <b>12. CONTROLLERS WITH CABINETS .....</b>                  | <b>53</b> |
| 12.1. MATERIALS – TYPE 170E CONTROLLERS .....               | 53        |
| 12.2. MATERIALS – TYPE 2070L CONTROLLERS .....              | 54        |
| 12.3. MATERIALS – NEMA TS-1 CONTROLLERS .....               | 55        |
| 12.4. MATERIALS – NEMA TS-2 TYPE 2 CONTROLLERS .....        | 55        |
| 12.5. MATERIALS – GENERAL CABINETS .....                    | 55        |
| 12.6. MATERIALS – TYPE 170E CABINETS .....                  | 56        |
| A. Type 170 E Cabinets General: .....                       | 56        |
| B. Type 170 E Cabinet Electrical Requirements: .....        | 57        |
| C. Type 170 E Cabinet Physical Requirements: .....          | 64        |
| D. Model 2018 Enhanced Conflict Monitor: .....              | 66        |
| E. Preemption and Sign Control Box .....                    | 75        |
| 12.7. MATERIALS – NEMA TS-1 CABINETS .....                  | 78        |
| A. NEMA TS-1 Cabinet Physical Requirements: .....           | 78        |
| B. NEMA TS-1 Cabinet Electrical Requirements: .....         | 80        |
| C. NEMA TS-1 Conflict Monitors: .....                       | 84        |
| 12.8. MATERIALS – NEMA TS-2 TYPE 1 CABINETS .....           | 85        |
| A. NEMA TS-2 Type 1 Cabinets General: .....                 | 85        |
| B. NEMA TS-2 Type 1 Cabinet Physical Requirements: .....    | 85        |
| C. NEMA TS-2 Type 1 Cabinet Electrical Requirements: .....  | 86        |
| 12.9. MATERIALS – TYPE 170 DETECTOR SENSOR UNITS .....      | 93        |
| 12.10. MATERIALS – NEMA TS-1 DETECTORS .....                | 93        |
| 12.11. MATERIALS – NEMA TS-2 DETECTOR CARDS AND RACKS ..... | 94        |
| 12.12. MATERIALS – TYPE 2070E CONTROLLERS .....             | 95        |
| <b>13. SPLICE CABINETS (TWISTED PAIR) .....</b>             | <b>95</b> |
| 13.1. DESCRIPTION .....                                     | 95        |
| 13.2. MATERIALS .....                                       | 95        |
| 13.3. CONSTRUCTION METHODS .....                            | 95        |
| 13.4. MEASUREMENT AND PAYMENT .....                         | 95        |
| <b>14. PORTABLE TRAFFIC SIGNAL SYSTEM .....</b>             | <b>96</b> |
| 14.1. DESCRIPTION .....                                     | 96        |
| 14.2. MATERIALS .....                                       | 96        |
| 14.3. CONSTRUCTION METHODS .....                            | 98        |
| 14.4. MEASUREMENT AND PAYMENT .....                         | 99        |
| <b>15. GPS UNIT .....</b>                                   | <b>99</b> |
| 15.1. DESCRIPTION .....                                     | 99        |
| 15.2. MATERIALS .....                                       | 99        |
| 15.3. CONSTRUCTION METHODS .....                            | 99        |
| 15.4. METHOD OF MEASUREMENT .....                           | 100       |

**TIP Number****County Name**

## Signals &amp; Intelligent Transportation Systems

|  |            |
|--|------------|
| 15.5. BASIS OF PAYMENT.....  | 100        |
| <b>16. PUSH BUTTON INTEGRATED ACCESSIBLE PEDESTRIAN SIGNAL (APS) .....</b>                                   | <b>100</b> |
| 16.1. DESCRIPTION .....  | 100        |
| 16.2. MATERIALS .....  | 100        |
| 16.3. CONSTRUCTION METHODS.....  | 101        |
| 16.4. MEASUREMENT AND PAYMENT .....  | 102        |
| <b>17. WIRELESS MAGNETIC SENSOR VEHICLE DETECTION SYSTEM.....</b>  | <b>102</b> |
| 17.1. DESCRIPTION .....  | 102        |
| 17.2. MATERIALS .....  | 102        |
| 17.3. CONSTRUCTION METHODS.....  | 103        |
| 17.4. MEASUREMENT AND PAYMENT .....  | 104        |
| <b>18. TEMPORARY STATIONARY TRAFFIC SIGNAL SYSTEM .....</b>  | <b>104</b> |
| 18.1. DESCRIPTION .....  | 104        |
| 18.2. MATERIALS .....  | 104        |
| 18.3. CONSTRUCTION METHODS.....  | 105        |
| 18.4. MEASUREMENT AND PAYMENT .....  | 105        |
| <b>19. PROTECTIVE POWDER COATING FOR METAL POLES WITH MAST ARMS AND PEDESTRIAN<br/>SIGNAL PEDESTALS.....</b> | <b>106</b> |
| 19.1. DESCRIPTION .....  | 106        |
| 19.2. MATERIALS .....  | 106        |
| 19.3. POWDER COATING SHOP APPROVAL .....   | 106        |
| 19.4. CONSTRUCTION METHODS.....  | 107        |
| A. <i>Galvanizing</i> .....  | 107        |
| B. <i>Surface Preparation</i> .....  | 107        |
| C. <i>Powder Coating Application and Curing</i> .....  | 108        |
| D. <i>Quality Control</i> :.....   | 108        |
| E. <i>Storage, Shipping, and Handling</i> .....  | 108        |
| F. <i>Repair of Powder Coated Material</i> .....   | 108        |
| 19.5. MEASUREMENT AND PAYMENT .....  | 109        |

**1. 2012 STANDARD SPECIFICATIONS FOR ROADS & STRUCTURES**

*The 2012 Standard Specifications are revised as follows:*

**1.1. Polymer Concrete (PC) Junction Boxes (1091-5(B))**

Page 10-202, revise paragraph starting on line 9 to read “Provide polymer concrete (PC) boxes which have bolted covers and open bottoms. Provide vertical extensions of 6" to 12" as required by project special provisions.”

Page 10-202, revise sentence beginning on line 14 to read “Other thermoplastic materials may be used for components which are not normally exposed to sunlight.”

**1.2. Junction Boxes (1098-5)**

Page 10-212, sub-Section 1098-5(C) Oversized Junction Boxes

Revise sentence to read, “Provide oversized junction boxes and covers with minimum inside dimensions of 28"(l) x 15"(w) x 22"(h).”

**1.3. Controllers with Cabinets – Material (1751-2)**

Page 17-37, Section 1751-2 Material

Add the following paragraph:

When the plans or specifications require a Type 2070L controller, contractor may provide a Type 2070E controller. Unless otherwise allowed by the Engineer, provide controllers of only one type.

**1.4. Pedestals (1743)**

Page 17-34, Add the following new sub-Section:

**1743-4 - Screw-In Helical Foundation Anchor Assembly**

**Description:**

Furnish and install screw-in helical foundation as an alternative to the standard reinforced concrete foundation specified in Article 1743 “Pedestals” of the Standard Specifications, for supporting Type I and Type II Pedestals. Do not use for Type III Pedestals.

**Materials for Type I – Pedestrian Pushbutton Post:**

Fabricate pipe assembly consisting of a 4” diameter x 56” long pipe, single helical blade and square fixed attachment plate. Furnish pipe in accordance with ASTM A-53 ERW Grade B and include a 2” x 3” cable opening in the pipe at 18” below the attachment plate. Furnish steel attachment plate and helical blade in accordance with ASTM A-36. Include (4) slotted mounting holes in the attachment plate to fit bolt circles ranging from 7-3/4” to 14-3/4" diameter. Furnish additional 3/4” keyholes at slotted holes to permit anchor bolt installation and replacement from top surface. Include combination bolt-head retainer and dirt scrapers at the attachment plate underside to allow for a level or flush-mount plate installation with respect to the finished grade. Galvanize pipe assembly components in accordance with AASHTO M 111 or an approved equivalent.

Furnish (4) 3/4"-10NC x 3” square head anchor bolts to meet the requirements of ASTM 325. Provide (4) 3/4” plain flat galvanized washers, (4) 3/16” thick galvanized plate washers and (4) 3/4" galvanized hex nuts. Galvanize in accordance with AASHTO M 111 or an approved equivalent.

**Construction Methods for Type I – Pedestrian Pushbutton Post:**

Advance or mechanically screw foundation into soil up until top of attachment plate is level with finished grade. Slide the anchor bolt heads through the keyhole openings and under the attachment plate with threads pointing up. Bolt the pedestal base to the foundation attachment plate. For further construction methods, see manufacturer's installation drawings.

**Materials for Type II – Normal-Duty Pedestal:**

Fabricate pipe assembly consisting of a 6" diameter x 60" long, single helical blade, 1-1/4" diameter stinger rod and square fixed attachment plate. Furnish pipe in accordance with ASTM A-53 ERW Grade B using schedule 40 wall thickness and include a 2" x 3" cable opening in the pipe at 18" below the attachment plate. Furnish steel attachment plate, helical blade and stinger rod in accordance with ASTM A-36. Include (4) slotted mounting holes in the attachment plate to fit bolt circles ranging from 10" to 15" diameter. Furnish additional 1-1/4" keyholes at slotted holes to permit anchor bolt installation and replacement from top surface. Include combination bolt-head retainer and dirt scrapers at the attachment plate underside to allow for a level or flush-mount plate installation with respect to the finished grade. Galvanize pipe assembly components in accordance with AASHTO M 111 or an approved equivalent.

Furnish (4) 1"-8NC x 4" galvanized Grade 5 square head anchor bolts. Provide (4) 1" plain flat galvanized washers and (4) 1" galvanized hex nuts. Galvanize in accordance with AASHTO M 111 or an approved equivalent.

**Construction Methods for Type II – Normal-Duty Pedestal:**

Advance or mechanically screw foundation into soil up until top of attachment plate is level with finished grade. Slide the anchor bolt heads through the keyhole openings and under the attachment plate with threads pointing up. Bolt the pedestal base to the foundation attachment plate.

For further construction methods, see manufacturer's installation drawings.

Page 17-34, revise Measurement and Payment to sub-Section 1743-5.

Revise the last paragraph to read:

No measurement will be made for pedestal foundations, pedestal screw-in helical foundations, grounding systems and any peripheral pedestal mounting hardware as these are incidental to furnishing and installing pedestals.

## **2. SIGNAL HEADS**

### **2.1. MATERIALS**

#### **A. General:**

Fabricate vehicle signal head housings and end caps from die-cast aluminum. Fabricate 12-inch and 16-inch pedestrian signal head housings and end caps from die-cast aluminum. Fabricate 9-inch pedestrian signal head housings, end caps, and visors from virgin polycarbonate material. Provide visor mounting screws, door latches, and hinge pins fabricated from stainless steel. Provide interior screws, fasteners, and metal parts fabricated from stainless steel or corrosion resistant material.

Fabricate tunnel and traditional visors from sheet aluminum.

Paint all surfaces inside and outside of signal housings and doors. Paint outside surfaces of tunnel and traditional visors, messenger cable mounting assemblies, pole and pedestal mounting

assemblies, and pedestrian pushbutton housings. Have electrostatically-applied, fused-polyester paint in highway yellow (Federal Standard 595C, Color Chip Number 13538) a minimum of 2.5 to 3.5 mils thick. Do not apply paint to the latching hardware or rigid vehicle signal head mounting brackets for mast-arm attachments.

Have the interior surfaces of tunnel and traditional visors painted an alkyd urea black synthetic baking enamel with a minimum gloss reflectance and meeting the requirements of MIL-E-10169, "Enamel Heat Resisting, Instrument Black."

For pole mounting, provide side of pole mounting assemblies with framework and all other hardware necessary to make complete, watertight connections of the signal heads to the poles and pedestals. Fabricate the mounting assemblies and frames from aluminum with all necessary hardware, screws, washers, etc. to be stainless steel. Provide mounting fittings that match the positive locking device on the signal head with the serrations integrally cast into the brackets. Provide upper and lower pole plates that have a 1 ¼-inch vertical conduit entrance hubs with the hubs capped on the lower plate and 1 ½-inch horizontal hubs. Ensure that the assemblies provide rigid attachments to poles and pedestals so as to allow no twisting or swaying of the signal heads. Ensure that all raceways are free of sharp edges and protrusions, and can accommodate a minimum of ten Number 14 AWG conductors.

For pedestal mounting, provide a post-top slipfitter mounting assembly that matches the positive locking device on the signal head with serrations integrally cast into the slipfitter. Provide stainless steel hardware, screws, washers, etc. Provide a minimum of six 3/8 X 3/4-inch long square head bolts for attachment to pedestal. Provide a center post for multi-way slipfitters.

For light emitting diode (LED) traffic signal modules, provide the following requirements for inclusion on the Department's Qualified Products List for traffic signal equipment.

1. Sample submittal,
2. Third-party independent laboratory testing results for each submitted module with evidence of testing and conformance with all of the Design Qualification Testing specified in section 6.4 of each of the following Institute of Transportation Engineers (ITE) specifications:
  - Vehicle Traffic Control Signal Heads – Light Emitting Diode (LED) Circular Signal Supplement
  - Vehicle Traffic Control Signal Heads – Light Emitting Diode (LED) Vehicle Arrow Traffic Signal Supplement
  - Pedestrian Traffic Control Signal Indications –Light Emitting Diode (LED) Signal Modules.

(Note: The Department currently recognizes two approved independent testing laboratories. They are Intertek ETL Semko and Light Metrics, Incorporated with Garwood Laboratories. Independent laboratory tests from other laboratories may be considered as part of the QPL submittal at the discretion of the Department,

3. Evidence of conformance with the requirements of these specifications,
4. A manufacturer's warranty statement in accordance with the required warranty, and

**Signals & Intelligent Transportation Systems**

5. Submittal of manufacturer's design and production documentation for the model, including but not limited to, electrical schematics, electronic component values, proprietary part numbers, bill of materials, and production electrical and photometric test parameters.
6. Evidence of approval of the product to bear the Intertek ETL Verified product label for LED traffic signal modules.

In addition to meeting the performance requirements for the minimum period of 60 months, provide a written warranty against defects in materials and workmanship for the modules for a period of 60 months after installation of the modules. During the warranty period, the manufacturer must provide new replacement modules within 45 days of receipt of modules that have failed at no cost to the State. Repaired or refurbished modules may not be used to fulfill the manufacturer's warranty obligations. Provide manufacturer's warranty documentation to the Department during evaluation of product for inclusion on Qualified Products List (QPL).

**B. Vehicle Signal Heads:**

Comply with the ITE standard "Vehicle Traffic Control Signal Heads". Provide housings with provisions for attaching backplates.

Provide visors that are 8 inches in length for 8-inch vehicle signal head sections. Provide visors that are 10 inches in length for 12-inch vehicle signal heads.

Provide a termination block with one empty terminal for field wiring for each indication plus one empty terminal for the neutral conductor. Have all signal sections wired to the termination block. Provide barriers between the terminals that have terminal screws with a minimum Number 8 thread size and that will accommodate and secure spade lugs sized for a Number 10 terminal screw.

Mount termination blocks in the yellow signal head sections on all in-line vehicle signal heads. Mount the termination block in the red section on five-section vehicle signal heads.

Furnish vehicle signal head interconnecting brackets. Provide one-piece aluminum brackets less than 4.5 inches in height and with no threaded pipe connections. Provide hand holes on the bottom of the brackets to aid in installing wires to the signal heads. Lower brackets that carry no wires and are used only for connecting the bottom signal sections together may be flat in construction.

For messenger cable mounting, provide messenger cable hangers, wire outlet bodies, balance adjusters, bottom caps, wire entrance fitting brackets, and all other hardware necessary to make complete, watertight connections of the vehicle signal heads to the messenger cable. Fabricate mounting assemblies from malleable iron or steel and provide serrated rings made of aluminum. Provide messenger cable hangers and balance adjusters that are galvanized before being painted. Fabricate balance adjuster eyebolt and eyebolt nut from stainless steel or galvanized malleable iron. Provide messenger cable hangers with U-bolt clamps. Fabricate washers, screws, bolts, clevis pins, cotter pins, nuts, and U-bolt clamps from stainless steel.

For mast-arm mounting, provide rigid vehicle signal head mounting brackets and all other hardware necessary to make complete, watertight connections of the vehicle signal heads to the mast arms and to provide a means for vertically adjusting the vehicle signal heads to proper alignment. Fabricate the mounting assemblies from aluminum, and provide serrated rings made of aluminum. Provide stainless steel cable attachment assemblies to secure the brackets to the mast arms. Ensure all fastening hardware and fasteners are fabricated from stainless steel.



**TIP Number****County Name**

## Signals &amp; Intelligent Transportation Systems

Provide LED vehicular traffic signal modules (hereafter referred to as modules) that consist of an assembly that uses LEDs as the light source in lieu of an incandescent lamp for use in traffic signal sections. Use LEDs that are aluminum indium gallium phosphorus (AlInGaP) technology for red and yellow indications and indium gallium nitride (InGaN) for green indications. Install the ultra bright type LEDs that are rated for 100,000 hours of continuous operation from -40°F to +165°F. Design modules to have a minimum useful life of 60 months and to meet all parameters of this specification during this period of useful life.

For the modules, provide spade terminals crimped to the lead wires and sized for a #10 screw connection to the existing terminal block in a standard signal head. Do not provide other types of crimped terminals with a spade adapter.

Ensure the power supply is integral to the module assembly. On the back of the module, permanently mark the date of manufacture (month & year) or some other method of identifying date of manufacture.

Tint the red, yellow and green lenses to correspond with the wavelength (chromaticity) of the LED. Transparent tinting films are unacceptable. Provide a lens that is integral to the unit with a smooth outer surface.

**1. LED Circular Signal Modules:**

Provide modules in the following configurations: 12-inch circular sections, and 8-inch circular sections. All makes and models of LED modules purchased for use on the State Highway System shall appear on the current NCDOT Traffic Signal Qualified Products List (QPL).

Provide the manufacturer's model number and the product number (assigned by the Department) for each module that appears on the 2012 or most recent Qualified Products List. In addition, provide manufacturer's certification in accordance with Article 106-3 of the *Standard Specifications*, that each module meets or exceeds the ITE "Vehicle Traffic Control Signal Heads – Light Emitting Diode (LED) Circular Signal Supplement" dated June 27, 2005 (hereafter referred to as VTCSH Circular Supplement) and other requirements stated in this specification.

Provide modules that meet the following requirements when tested under the procedures outlined in the VTCSH Circular Supplement:

| Module Type            | Max. Wattage at 165° F | Nominal Wattage at 77° F |
|------------------------|------------------------|--------------------------|
| 12-inch red circular   | 17                     | 11                       |
| 8-inch red circular    | 13                     | 8                        |
| 12-inch green circular | 15                     | 15                       |
| 8-inch green circular  | 12                     | 12                       |

For yellow circular signal modules, provide modules tested under the procedures outlined in the VTCSH Circular Supplement to insure power required at 77° F is 22 Watts or less for the 12-inch circular module and 13 Watts or less for the 8-inch circular module.

Note: Use a wattmeter having an accuracy of  $\pm 1\%$  to measure the nominal wattage and maximum wattage of a circular traffic signal module. Power may also be derived from voltage, current and power factor measurements.

**2. LED Arrow Signal Modules**

Provide 12-inch omnidirectional arrow signal modules. All makes and models of LED modules purchased for use on the State Highway System shall appear on the current NCDOT Traffic Signal Qualified Products List (QPL).

Provide the manufacturer’s model number and the product number (assigned by the Department) for each module that appears on the 2012 or most recent Qualified Products List. In addition, provide manufacturer’s certification in accordance with Article 106-3 of the *Standard Specifications*, that each module meets or exceeds the requirements for 12-inch omnidirectional modules specified in the ITE “Vehicle Traffic Control Signal Heads – Light Emitting Diode (LED) Vehicle Arrow Traffic Signal Supplement” dated July 1, 2007 (hereafter referred to as VTCSH Arrow Supplement) and other requirements stated in this specification.

Provide modules that meet the following requirements when tested under the procedures outlined in the VTCSH Arrow Supplement:

| Module Type         | Max. Wattage at 165° F | Nominal Wattage at 77° F |
|---------------------|------------------------|--------------------------|
| 12-inch red arrow   | 12                     | 9                        |
| 12-inch green arrow | 11                     | 11                       |

For yellow arrow signal modules, provide modules tested under the procedures outlined in the VTCSH Arrow Supplement to insure power required at 77° F is 12 Watts or less.

Note: Use a wattmeter having an accuracy of  $\pm 1\%$  to measure the nominal wattage and maximum wattage of an arrow traffic signal module. Power may also be derived from voltage, current and power factor measurements.

**C. Pedestrian Signal Heads:**

Provide pedestrian signal heads with international symbols that meet the MUTCD. Do not provide letter indications.

Comply with the ITE standard for “Pedestrian Traffic Control Signal Indications” and the following sections of the ITE standard for “Vehicle Traffic Control Signal Heads” in effect on the date of advertisement:

- Section 3.00 - “Physical and Mechanical Requirements”
- Section 4.01 - “Housing, Door, and Visor: General”
- Section 4.04 - “Housing, Door, and Visor: Materials and Fabrication”
- Section 7.00 - “Exterior Finish”

Provide a double-row termination block with three empty terminals and number 10 screws for field wiring. Provide barriers between the terminals that accommodate a spade lug sized for number 10 terminal screws. Mount the termination block in the hand section. Wire all signal sections to the terminal block.

Where required by the plans, provide 16-inch pedestrian signal heads with traditional three-sided, rectangular visors, 6 inches long. Where required by the plans, provide 12-inch pedestrian signal heads with traditional three-sided, rectangular visors, 8 inches long.

**TIP Number****County Name**

## Signals &amp; Intelligent Transportation Systems

Provide 2-inch diameter pedestrian push-buttons with weather-tight housings fabricated from die-cast aluminum and threading in compliance with the NEC for rigid metal conduit. Provide a weep hole in the housing bottom and ensure that the unit is vandal resistant.

Provide push-button housings that are suitable for mounting on flat or curved surfaces and that will accept 1/2-inch conduit installed in the top. Provide units that have a heavy duty push-button assembly with a sturdy, momentary, normally-open switch. Have contacts that are electrically insulated from the housing and push-button. Ensure that the push-buttons are rated for a minimum of 5 mA at 24 volts DC and 250 mA at 12 volts AC.

Provide standard R10-3 signs with mounting hardware that comply with the MUTCD in effect on the date of advertisement. Provide R10-3E signs for countdown pedestrian heads and R10-3B for non-countdown pedestrian heads.

Design the LED pedestrian traffic signal modules (hereafter referred to as modules) for installation into standard pedestrian traffic signal sections that do not contain the incandescent signal section reflector, lens, eggcrate visor, gasket, or socket. Provide modules that consist of an assembly that uses LEDs as the light source in lieu of an incandescent lamp. Use LEDs that are of the latest aluminum indium gallium phosphorus (AlInGaP) technology for the Portland Orange hand and countdown displays. Use LEDs that are of the latest indium gallium nitride (InGaN) technology for the Lunar White walking man displays. Install the ultra-bright type LEDs that are rated for 100,000 hours of continuous operation from -40°F to +165°F. Design modules to have a minimum useful life of 60 months and to meet all parameters of this specification during this period of useful life.

Design all modules to operate using a standard 3 - wire field installation. Provide spade terminals crimped to the lead wires and sized for a #10 screw connection to the existing terminal block in a standard pedestrian signal housing. Do not provide other types of crimped terminals with a spade adapter.

Ensure the power supply is integral to the module assembly. On the back of the module, permanently mark the date of manufacture (month & year) or some other method of identifying date of manufacture.

Provide modules in the following configuration: 16-inch displays which have the solid hand/walking man overlay on the left and the countdown on the right, and 12-inch displays which have the solid hand/walking man module as an overlay. All makes and models of LED modules purchased for use on the State Highway System shall appear on the current NCDOT Traffic Signal Qualified Products List (QPL).

Provide the manufacturer's model number and the product number (assigned by the Department) for each module that appears on the 2012 or most recent Qualified Products List. In addition, provide manufacturer's certification in accordance with Article 106-3 of the *Standard Specifications*, that each module meets or exceeds the ITE "Pedestrian Traffic Control Signal Indicators - Light Emitting Diode (LED) Signal Modules" dated August 04, 2010 (hereafter referred to as PTCSI Pedestrian Standard) and other requirements stated in this specification.

Provide modules that meet the following requirements when tested under the procedures outlined in the PTCSI Pedestrian Standard:

| Module Type     | Max. Wattage at 165° F | Nominal Wattage at 77° F |
|-----------------|------------------------|--------------------------|
| Hand Indication | 16                     | 13                       |

**TIP Number****County Name**

## Signals &amp; Intelligent Transportation Systems

|                        |    |    |
|------------------------|----|----|
| Walking Man Indication | 12 | 9  |
| Countdown Indication   | 16 | 13 |

Note: Use a wattmeter having an accuracy of  $\pm 1\%$  to measure the nominal wattage and maximum wattage of a circular traffic signal module. Power may also be derived from voltage, current and power factor measurements.

Provide module lens that is hard coated or otherwise made to comply with the material exposure and weathering effects requirements of the Society of Automotive Engineers (SAE) J576. Ensure all exposed components of the module are suitable for prolonged exposure to the environment, without appreciable degradation that would interfere with function or appearance.

Ensure the countdown display continuously monitors the traffic controller to automatically learn the pedestrian phase time and update for subsequent changes to the pedestrian phase time.

Ensure the countdown display begins normal operation upon the completion of the preemption sequence and no more than one pedestrian clearance cycle.

**D. Signal Cable:**

Furnish 16-4 and 16-7 signal cable that complies with IMSA specification 20-1 except provide the following conductor insulation colors:

- For 16-4 cable: white, yellow, red, and green
- For 16-7 cable: white, yellow, red, green, yellow with black stripe tracer, red with black stripe tracer, and green with black stripe tracer. Apply continuous stripe tracer on conductor insulation with a longitudinal or spiral pattern.

Provide a ripcord to allow the cable jacket to be opened without using a cutter. IMSA specification 19-1 will not be acceptable. Provide a cable jacket labeled with the IMSA specification number and provide conductors constructed of stranded copper.

**E. Optically-Programmed Vehicle Signal Sections:**

Material, equipment, and hardware furnished under this section must be pre-approved on the Department's QPL by the date of installation.

Design the programmable signal sections to tilt in two degree increments for a maximum of ten degrees above and ten degrees below horizontal, while still maintaining a common vertical axis.

Design the programmable signal sections to mount to standard signal sections to form a signal head. Ensure that the programmable signal sections have a mounting system compatible with the standard 1 1/2-inch traffic signal fittings.

Provide an optical system consisting of a lamp, a diffuser, an optical limiter, and an objective lens. Ensure that all programming is accomplished optically with no hoods or louvers necessary to accomplish the programming. Provide optical masking tape with each section.

Provide a 150-Watt, 115 VAC lamp with integral reflector and rated output of 1750 lumens. Ensure that the average rated life is at least 6000 hours.

Provide a high resolution, annular, incremental lens. Ensure that the lens and door are sealed to provide a moisture and dust proof seal. Provide a red, yellow, or green ball or arrow indication as specified by the bid list, plans, or purchase order.

**F. Louvers:**

Material, equipment, and hardware furnished under this section must be pre-approved on the Department's QPL by the date of installation.

Provide louvers made from sheet aluminum. Paint the louvers alkyd urea black synthetic baked enamel with a minimum gloss reflectance and meeting the requirements of MIL-E-10169, "Enamel Heat Resisting, Instrument Black."

Ensure that the louvers have a 0-degree horizontal viewing angle. Provide a minimum of 5 vanes.

**3. VIDEO IMAGING LOOP EMULATOR DETECTOR SYSTEMS**

**3.1. DESCRIPTION**

Design, furnish, provide training, and install video imaging loop emulator detection systems with all necessary hardware in accordance with the plans and specifications.

Unless otherwise specified in the contract, all loop emulator detection equipment will remain the property of the contractor.

**3.2. MATERIALS**

**A. General:**

Material and equipment furnished under this section must be pre-approved on the Department's QPL by the date of installation except miscellaneous hardware such as cables and mounting hardware do not need to be pre-approved.

Used equipment will be acceptable provided the following conditions have been met:

- Equipment is listed on the current QPL.
- Equipment is in good working condition.
- Equipment is to remain the property of the contractor.

Ensure that software is licensed for use by the Department and by any other agency responsible for maintaining or operating the loop emulation system. Provide the Department with a license to duplicate and distribute the software as necessary for design and maintenance support.

Design and furnish video imaging loop emulator detection systems that detect vehicles at signalized intersections by processing video images and providing detection outputs to the signal controller in real time (within 112 milliseconds of vehicle arrival).

Furnish all required camera sensor units, loop emulator processor units, hardware and software packages, cabling, poles, mast arms, harnesses, camera mounting assemblies, surge protection panels, grounding systems, messenger cable and all necessary hardware. Furnish systems that allow the display of detection zones superimposed on an image of the roadway on a Department-furnished monitor or laptop computer screen. Ensure detection zones can be defined and data entered using a simple keyboard or mouse and monitor, or using a laptop PC with software.

Provide design drawings showing design details and camera sensor unit locations for review and acceptance before installation. Provide mounting height and location requirements for camera sensor units on the design based on site survey. Design video imaging loop emulator detection systems with

**Signals & Intelligent Transportation Systems**

all necessary hardware. Indicate all necessary poles, spans, mast arms, luminaire arms, cables, camera mounting assemblies and hardware to achieve the required detection zones where Department owned poles are not adequate to locate the camera sensor units. Do not design for the installation of poles in medians.

Obtain the Engineer's approval before furnishing video imaging loop emulator detection systems. The contractor is responsible for the final design of video imaging loop emulator detection systems. Review and acceptance of the designs by the Department does not relieve the contractor from the responsibility to provide fully functional systems and to ensure that the required detection zones can be provided.

Provide the ability to program each detection call (input to the controller) with the following functions:

- Full Time Delay – Delay timer is active continuously,
- Normal Delay – Delay timer is inhibited when assigned phase is green (except when used with TS 2 and 170/2070L controllers),
- Extend – Call is extended for this amount of time after vehicle leaves detection area,
- Delay Call/Extend Call – This feature uses a combination of full time delay and extend time on the same detection call. Ensure operation is as follows: Vehicle calls are received after the delay timer times out. When a call is detected, it is held until the detection area is empty and the programmed extend time expires. If another vehicle enters the detection area before the extend timer times out, the call is held and the extend time is reset. When the extend timer times out, the delay timer has to expire before another vehicle call can be received.

Provide the ability to program each detection zone as one of the following functions:

- Presence detector,
- Directional presence detector,
- Pulse detector,
- Directional pulse detector.

Ensure previously defined detector zones and configurations can be edited.

Provide each individual system with all the necessary equipment to focus and zoom the camera lenses without the need to enter the camera enclosure.

Provide systems that allow for the placement of at least 8 detection zones within the combined field of view of a single camera sensor unit. Provide a minimum of 8 detection outputs per camera.

Provide detection zones that can be overlapped. Ensure systems reliably detect vehicles when the horizontal distance from the camera sensor unit to the detection zone area is less than ten times the mounting height of the sensor. Ensure systems detect vehicles in multiple travel lanes.

Ensure systems can detect vehicle presence within a 98 to 102 percent accuracy (up to 2 percent of the vehicles missed and up to 2 percent of false detection) for clear, dry, daylight conditions, a 96 to 105 percent accuracy (up to 4 percent of the vehicles missed and up to 5 percent false detection) for dawn and dusk conditions, and a 96 percent accuracy (up to 4 percent of the vehicles missed) for night and adverse conditions (fog, snow, rain, etc.) using standard sensor optics and in the absence of occlusion.

## Signals &amp; Intelligent Transportation Systems

Repair and replace all failed components within 72 hours.

The Department may conduct field-testing to ensure the accuracy of completed video imaging loop emulator detection systems.

**B. Loop Emulator System:**

Furnish loop emulator systems that receive and simultaneously process information from camera sensor units, and provides detector outputs to signal controllers.

Ensure systems provide the following:

- Operate in a typical roadside environment and meet the environmental specifications and are fully compatible with NEMA TS 1, NEMA TS 2, or Type 170/2070L controllers and cabinets,
- provide a “fail-safe” mode whereby failure of one or more of the camera sensor units or power failure of the loop emulator system will cause constant calls to be placed on the affected vehicle detection outputs to the signal controller,
- provide compensation for minor camera movement of up to 2 percent of the field of view at 400 feet without falsely detecting vehicles,
- process the video at a minimum rate of 30 times per second,
- provide separate wired connectors inside the controller cabinet for video recording each camera,
- provide remote video monitoring with a minimum refresh rate at 1 frame per second over a standard dial-up telephone line,
- provide remote video detection monitoring.

Furnish camera sensor units that comply with the following:

- have an output signal conforming to EIA RS-170 standard,
- have a nominal output impedance of 75 ohms,
- be immune to bright light sources, or have built in circuitry or protective devices to prevent damage to the sensor when pointed directly at strong light sources,
- be housed in a light colored environmental enclosure that is water proof and dust tight, and that conforms to NEMA-4 specifications or better,
- simultaneously monitor at least five travel lanes when placed at the proper mounting location with a zoom lens,
- have a sunshield attached to the environmental enclosure to minimize solar heating,
- meet FCC class B requirements for electromagnetic interference emissions,
- have a heater attached to the viewing window of the environmental enclosure to prevent ice and condensation in cold weather.

Where coaxial video cables and other cables are required between the camera sensor and other components located in the controller cabinet, furnish surge protection in the controller cabinet.

If furnishing coaxial communications cable comply with the following, as recommended by the approved loop emulator manufacturer:

- Number 20 AWG, solid bare copper conductor terminated with crimped-on BNC connectors (do not use BNC adapters) from the camera sensor to the signal controller cabinet.
- Number 22 AWG, stranded bare copper conductor terminated with crimped-on BNC connectors (do not use BNC adapters) from the camera sensor unit to the junction box, and within the signal controller cabinet.

Furnish power cable appropriately sized to meet the power requirements of the sensors. At a minimum, provide three conductor 120 VAC field power cable.

As determined during the site survey, furnish sensor junction boxes with nominal 6 x 10 x 6 inches dimensions at each sensor location. Provide terminal blocks and tie points for coaxial cable.

### **C. Video Imaging Loop Emulator System Support:**

Furnish video imaging loop emulator systems with either a simple keyboard or a mouse with monitor and appropriate software, or with system software for use on department-owned laptop PCs. Ensure the system is Windows 2000 and Windows XP compatible.

Provide Windows 2000 and Windows XP compatible personal computer software, if needed, to provide remote video and video detection monitoring.

Ensure systems allow the user to edit previously defined detector configurations. When a vehicle is within a detection zone, provide for a change in color or intensity of the detection zone perimeter or other appropriate display changes on the Department-furnished monitor or laptop computer screen.

Provide cabling and interconnection hardware with 6-foot minimum length interconnection cable to interface with the system.

Provide all associated equipment manuals and documentation.

### **3.3. CONSTRUCTION METHODS**

Arrange and conduct site surveys with the system manufacturer's representative and Department personnel to determine proper camera sensor unit selection and placement. Provide the Department at least 3 working days notice before conducting site surveys. Upon completion of the site surveys the Department will provide revised plans reflecting the findings of the site survey.

Before beginning work at locations requiring video imaging loop emulator detection systems, furnish system software. Upon activation of detection zones, provide detector configuration files. Ensure that up-to-date detection configuration files are furnished for various detection zone configurations that may be required for construction phasing.

Place into operation loop emulator detection systems. Configure loop emulator detection systems to achieve required detection in designated zones. Have a certified manufacturer's representative on site to supervise and assist with installation, set up, and testing of the system.

Install the necessary processing and communications equipment in the signal controller cabinet. Make all necessary modifications to install equipment, cabling harnesses, and camera sensor interface panels with surge suppression.



Perform modifications to camera sensor unit gain, sensitivity, and iris limits necessary to complete the installation.

Do not install camera sensor units on signal poles unless approved by the Engineer.

Install the necessary cables from each sensor to the signal controller cabinet along signal cabling routes. Install surge protection and terminate all cable conductors.

Relocate camera sensor units and reconfigure detection zones as necessary according to the plans for construction phases.

Provide at least 8 hours of training on the set up, operation, troubleshooting, and maintenance of the loop emulator detection system to a maximum of ten Department personnel. Arrange for training to be conducted by the manufacturer's representative at an approved site within the Division responsible for administration of the project. Thirty days before conducting training submit a detailed course curriculum, draft manuals and materials, and resumes. Obtain approval of the submittal before conducting the training. At least one week before beginning training, provide three sets of complete documentation necessary to maintain and operate the system. Do not perform training until installation of loop emulator detection systems is complete.

**3.4. MEASUREMENT AND PAYMENT**

Actual number of site surveys, arranged, conducted, and accepted.

Actual number of luminaire arms for video systems furnished, installed, and accepted.

Actual number of cameras with internal loop emulator processing units furnished, installed, and accepted.

Actual number of cameras without internal loop emulator processing units furnished, installed, and accepted.

Actual number of external loop emulator processing units furnished, installed, and accepted.

Actual number of camera sensor units relocated with detection zones reconfigured installed, and accepted.

No measurement will be made of video imaging loop emulator system support or training, power and video cables, and trenching as these items will be considered incidental to furnishing and installing video imaging loop emulator detection systems.

Payment will be made under:

|   |      |
|---|------|
| Site Survey.....  | Each |
| Luminaire Arm for Video System .....                        | Each |
| Camera with Internal Loop Emulator Processing Unit .....    | Each |
| Camera without Internal Loop Emulator Processing Unit ..... | Each |
| External Loop Emulator Processing Unit.....                 | Each |
| Relocate Camera Sensor Unit.....                            | Each |

**4. MICROWAVE VEHICLE DETECTOR**

**4.1. DESCRIPTION**

Furnish and install a microwave vehicle detection unit and manufacturer recommended cables and hardware in accordance with the plans and specifications.

**4.2. MATERIALS**

Furnish material, equipment, and hardware under this section that is pre-approved on the ITS and Signals QPL.

Provide a detector for either side-fire or forward-fire configuration with a mounting height of 16 inches or greater for normal operation. Ensure the detector will detect vehicle in sunny, cloudy, rainy, snowy, and foggy weather conditions with self-tuning to auto-adjust in changing environmental conditions. Ensure the detector can operate from the voltage supplied by a NEMA and Type-170 traffic signal cabinet. Ensure the detector can provide detection calls to the traffic signal controller within a NEMA and Type-170 cabinet. Ensure the detector will put out a constant call in the event of a component failure or loss of power. Ensure the detector has an operating temperature range of -20 to 150 degrees F. Ensure a water resistant housing for the detector.

For advance pulse detection, ensure the detector senses vehicles in motion at a range of 200 feet with an operating frequency of 10.525 GHz +/- 25MHz.

For stop bar presence detection, ensure the detector outputs a constant call while a vehicle is in the detection zone. Ensure the presence detection unit can cover a detection zone as shown on the plans and has an effective range of at least 75 feet from the detector unit to the aim point on the road surface.

For units without an integrated card rack interface, provide Form C output relay contacts rated a minimum of 3A, 24VDC.

If a laptop is used to adjust detector settings, ensure that software is licensed for use by the Department and by any other agency responsible for maintaining or operating the microwave detection system. Provide the Department with a license to duplicate and distribute the software as necessary for design and maintenance support.

**4.3. CONSTRUCTION METHODS**

Install the microwave vehicle detector in accordance with the manufacturer’s recommendations.

Monitor and maintain the detector unit during construction to ensure microwave vehicle detector is functioning properly and aimed for the detection zone shown in the plans. Refer to Subarticle 1700-3 (D) Maintenance and Repair of Materials of the *Standard Specifications* for failure to maintain the microwave detection system.

**4.4. MEASUREMENT AND PAYMENT**

Actual number of microwave vehicle detector units furnished, installed, and accepted.

No measurement will be made of cables or hardware, as these will be considered incidental to furnishing and installing microwave vehicle detectors.

Payment will be made under:

Microwave Vehicle Detector..... Each

**5. TWISTED-PAIR COMMUNICATIONS CABLE**

**5.1. DESCRIPTION**

Furnish and install twisted-pair communications cable with all necessary hardware in accordance with the plans and specifications.

**5.2. MATERIALS**

**A. General:**

Furnish communications cable with all other tools, materials, and hardware required for successful completion of the work, including but not limited to communications cable identification markers (cable wraps), couplings, connectors, machine bolts, eye bolts, strandvises, cable suspension clamps, and pole bands.

**B. Communications Cable:**

Furnish the following:

- IMSA 20-2 or RUS CFR 1755.390 \_\_\_\_-pair, 19-gauge, shielded, twisted-pair communications cable (lashed to existing messenger cable)
- IMSA 20-4 \_\_\_\_-pair, 19-gauge, shielded, twisted-pair communications cable (self supporting)
- RUS CFR 1755.390 \_\_\_\_-pair, 19-gauge, shielded, twisted-pair communications cable (underground)

Have the manufacturer factory test the communications cable on reels for each pair's mutual capacitance, crosstalk loss, insulation resistance, and conductor resistance. Furnish the Engineer with a certified report for each reel showing compliance with the IMSA or RUS specification, the factory test results, and the manufactured date of the cable. Do not use communications cable manufactured more than one year before the date of installation.

Provide sequential foot markings within one percent of the actual cable length and as required by Section 350G of the National Electrical Safety Code. Provide approximately 1/10-inch character height of the markings.

**C. Communications Cable Identification Markers (Cable Wraps):**

Furnish yellow communications cable identification markers that are resistant to fading when exposed to UV sources and changes in weather. Use markers designed to coil around the communications cable and that do not slide or move along the surface of the communications cable once installed. Ensure that exposure to UV light and weather does not affect the markers natural coiling effect or deteriorate its performance. Provide communications cable wraps that permit writing with an indelible marking pen and that contain the following text in black:

|  |
|--|
| <p style="text-align: center;"><b>WARNING</b><br/><b>NCDOT COMMUNICATIONS CABLE</b><br/><b>CONTACT TELEPHONE NUMBER:</b><br/>_____<br/><b>WARNING</b><br/><b>NCDOT COMMUNICATIONS CABLE</b><br/><b>CONTACT TELEPHONE NUMBER:</b><br/>_____</p> |
|--|

*Overall Marker Dimensions: 7(l) x 4 (w) inches*

*Lettering Height: 3/8 inch for "WARNING"*

*1/4 inch for all other lettering*

### **5.3. CONSTRUCTION METHODS**

#### **A. General:**

Install communications cable on traffic signal and utility poles, and in conduits to bring the cable into and, if necessary, out of each controller cabinet.

Take all precautions necessary to ensure the communications cable is not damaged during storage and installation. Do not step on the cable nor run over the cable with vehicles or equipment. Do not pull the cable over or around obstructions, or along the ground.

Immediately cease work and notify the Engineer and the affected owner should damage to existing cables or equipment occur. Make the required repairs at no additional cost to the Department.

Provide the Engineer with three copies of the communications cable manufacturer's recommended and maximum pulling tension for each communications cable size before the installation of communications cable.

Install communications cable in continuous lengths from one signalized intersection to the next with no splices outside the cabinet.

Keep the communications cable ends sealed at all times during installation to effectively prevent the ingress of moisture. Use a silicone impregnated heat shrink cable end cap approved by the Engineer. Do not use tape to seal the cable ends.

Notify the Engineer in writing a minimum of ten days before beginning communications cable testing.

Test the integrity of the communications cable before installation based on IMSA 20-4, 19-gauge wire standard.

Test the cable insulation for a resistance of more than 500 megaohms for each insulated conductor when measured with all other insulated conductors and the shielded ground before installation. Make the measurement with a DC potential of at least 100 volts but not more than 550 volts applied for 1 minute. Furnish the test results to the Engineer.

Wire communications cable into the cabinet. Allow a minimum of 10 feet of slack for communications cable that is not immediately terminated.

#### **B. Aerial Installation:**

Use pole attachment hardware and roller guides with safety clips to install the aerial communications cable.

Maintain tension during the pulling process for aerial run communications cable by using a mechanical clutch (dynamometer) device approved by the Engineer. Do not exceed 80 percent of the manufacturer's maximum allowable pulling tension. Do not allow the communications cable to

contact the ground or other obstructions between the poles during installation. Do not use a motorized vehicle to generate cable-pulling forces.

- **On Messenger Cable**

Double lash the communications cable to the messenger cable where the messenger cable is used solely to support the communications cable.

Wrap the communications cable to the messenger cable using aluminum ribbon wraps where the messenger cable supports other cables (i.e., traffic signal cable, lead-in cable, etc.).

- **With Integral Messenger Cable**

Use 5/8-inch diameter machine bolts to attach suspension clamps to the wood poles for attaching integral messenger cable. Provide machine bolts with washers and square nuts that are 3 inches longer than the pole diameter.

Use 5/8-inch diameter eyebolts with washers and nuts (or eyenuts if required) to attach strandvises to the wood poles at controller cabinets and poles where messenger cable is terminated into a strandvise. Secure the messenger cable to the strandvises with an eyebolt or nut so that the messenger cable will not pull out unless intentionally released. Install the cable suspension clamps directly to the jacketed messenger cable without crushing into the cable core jacket. Do not split or strip the jacket for attachment to the cable suspension clamp. Use pole bands to make acute turns at poles that cannot accommodate separate eyebolts. Use a cable suspension clamp when attaching communications cable tangent to the pole.

Strip the messenger cable from the integral communications cable that is installed in risers and controller cabinets or is lashed to existing cables. Use a figure-8 cable splitter specifically designed for splitting the communications cable at the web between the messenger cable and the conductors for removing the messenger cable. Replace the entire segment of communications cable at no additional cost to the Department if the communications cable, shield, conductors, or messenger cable are damaged. Do not splice the cable or repair the insulation. Install two cable-lashing straps at the end of each split to prevent further splitting of the figure-8 web.

### **C. Underground Installation:**

Install underground communications cable in 2-inch PVC conduit using cable-pulling lubricants approved by the communications cable manufacturer and the Engineer. Obtain the Engineer's approval of the cable lubricant and method of pulling before the installation of underground communications cable.

Do not exceed 80 percent of the manufacturer's maximum pulling tension when installing underground communications cable.

Use a clutch device (dynamometer) so as not to exceed the allowable pulling tension if the cable is pulled by mechanical means. Do not use a motorized vehicle to generate cable-pulling forces.

Keep tension on the cable reel and the pulling line at the start of each pull. Do not release the tension in the cable if the pulling operation is halted. Restart the pulling operation by gradually increasing the tension until the cable is in motion.

Set cable reels up on the same side of the junction box as the conduit section in which the cable is to be installed. Place the reel level and align the reel with the conduit section such that the cable will pass from the top of the reel in a smooth bend into the conduit without twisting. Do not pull the

cable from the bottom of the reel. Manually feed the cable by rotating the reel. Do not pull the cable through intermediate junction boxes, pull boxes, handholes, or openings in conduit unless otherwise approved by the Engineer.

**D. Bonding and Splicing:**

Terminate all cable pairs in a neatly arranged manner. Use binding-type screw terminal strips of sufficient size to terminate all cable pairs. Clean the terminals before terminating the cable. Apply non-insulated, Number 18-20, spade crimp terminals to the cable using a calibrated ratchet type crimp tool. Solder the terminals and coat the binding-type screw terminal strips and connections with a corrosive-prevention material after crimping.

Splice communications cable within the controller cabinets and splice cabinets. Do not splice within pull boxes.

Ground the shield of the outgoing cable (going away from the master controller) to a ground rod using insulated (green) number 14 AWG standard copper wire at all controller cabinet locations. Leave the shield of the incoming cable ungrounded. Bond and ground the cable shields as required by RUS CFR 1755.200.

**E. Cable Identification Markers:**

Install one communications cable identification marker within 3 feet of all pole attachment points and at locations where more than one cable originates or terminates. Install one communications cable identification marker in all pull boxes where communications cable is installed.

**5.4. MEASUREMENT AND PAYMENT**

Actual linear feet of twisted-pair communications cable furnished, installed, and accepted. Measurement will be made by calculating the difference in length markings located on the outer jacket of the twisted-pair communications cable from the start of the cable run to the end of the cable run for each cable run. All pairs shall be terminated before determining the length of cable run.

No measurement will be made of communications cable identification markers as these will be considered incidental to furnishing and installing communications cable.

Payment will be made under:

Communications Cable (\_\_\_-Twisted-pair) .....Linear Foot

**6. COMMUNICATIONS SYSTEM SUPPORT EQUIPMENT**

**6.1. DESCRIPTION**

Furnish communications system support equipment with all necessary hardware in accordance with the plans and specifications.

**6.2. MATERIALS**

**A. General:**

Furnish equipment with test probes/leads, batteries (for battery-operated units), line cords (for AC-operated units), and carrying cases. Provide operating instructions and maintenance manuals with each item.

Before starting any system testing or training, furnish all communications system support equipment.

**B. Fiber-Optic Support Equipment**

**B.1 Fiber-optic Restoration Kit:**

Furnish a fully functional fiber-optic restoration kit consisting of the following items (minimum):

- Plier-type strippers
- Non-niks fiber stripper tool with procedures
- Buffer tube stripper tool with procedures
- Fiber-optic Cleaver (average cut less than 0.5 degrees from perpendicular) Diamond Blade
- Screw driver set
- 48 Alcohol wipes
- Tape, 3/4-inch, electrician
- Chemical removal wipes
- Metal ruler
- Tweezers
- Crimping pliers
- Mechanical Splice Manual
- Mechanical Splice Fixture
- 12, Non-adhesive, mechanical splices
- 2 Mechanical Splice Trays, 12 Mechanical Splice Devices, Compatible with the Interconnect Centers being installed in the Traffic Signal Controller Cabinets
- Scissors
- Hard-sided, padded, storage case

**B.2 Fiber-optic Power Meter:**

Furnish fiber-optic power meters for measuring absolute power and link losses, as well as monitoring power levels and testing threshold levels. Provide the following features:

- Spectral range ..... 750 nm to 1700 nm
- Calibrated wavelengths ..... 850, 1310, and 1550 nm
- Accuracy .....  $\pm 3$  percent ( $\pm 0.1$  dB) at -20 dBm at 70 degrees F  
at calibrated wavelengths
- Readout resolution ..... 4 digits, 0.01 dBm
- Display ..... Backlit LCD
- Fiber-optic connector ..... ST type

**TIP Number**

**County Name**

Signals & Intelligent Transportation Systems

- Power-up stabilization ..... Less than five seconds at ambient temperature
- Tone threshold settings ..... User selectable from 1 to 35 dB, plus OFF
- Analog output port
  - Voltage ..... 0 to + 1 V FSD of linear power range
  - Output impedance ..... 5 kilohms, nominal
- Temperature
  - Operating ..... 32 to 122 degrees F
  - Storage ..... 0 to 150 degrees F
- Relative humidity ..... 5 to 95 percent, non-condensing
- Battery power ..... Alkaline: 28 hours; NiCad: 8 hours (recharger and NiCad batteries provided)
- Carrying case

**B.3 Optical Light Generator:**

Furnish optical light generators for measuring absolute power and link losses, as well as monitoring power levels and testing threshold levels. Provide the following features:

- Calibrated wavelengths ..... 1310 nm, and 1550 nm
- Accuracy ..... 3 percent at 70 degrees F at calibrated wavelengths
- Fiber-optic connector ..... ST type
- Power-up stabilization ..... Less than five seconds at ambient temperature
- Temperature
  - Operating ..... 32 to 122 degrees F
  - Storage ..... -10 to 150 degrees F
- Relative humidity ..... 5 to 95 percent, non-condensing
- Battery power ..... Alkaline: 28 hours; NiCad: 8 hours (recharger and NiCad batteries provided)
- Carrying case

**B.4 SMFO Transceiver (For Emergency Restoration):**

Furnish SMFO transceivers identical to the type installed in the traffic signal controller cabinets to be used for emergency restoration of the system and the fiber-optic communications system.

**C. Wireless Radio Support Equipment**

**C.1 Wireless Radio Modem**



Furnish wireless radio modem identical to the type installed in the traffic signal controller cabinets to be used for emergency restoration of the system and the wireless communications system.

**C.2 Lightning Arrestor**

Furnish wireless radio lightning arrestors identical to the type installed in the traffic signal controller cabinets to be used for emergency restoration of the transient voltage suppression equipment.

**6.3. MEASUREMENT AND PAYMENT**

Actual number of fiber-optic restoration kits furnished and accepted.

Actual number of fiber-optic power meters furnished and accepted.

Actual number of optical light generators furnished and accepted.

Actual number of fiber-optic transceivers furnished and accepted.

Actual number of wireless radio modems furnished and accepted.

Actual number of wireless radio lightning arrestors furnished and accepted.

Payment will be made under:

|   |      |
|---|------|
| Furnish Fiber-optic Restoration Kit ..... | Each |
| Furnish Fiber-optic Power Meter.....      | Each |
| Furnish Fiber-optic Light Generator ..... | Each |
| Furnish Fiber-optic Transceiver.....      | Each |
| Furnish Wireless Radio Modem .....        | Each |
| Furnish Wireless Lightning Arrestor ..... | Each |

**7. FIBER-OPTIC TRAINING**

**7.1. DESCRIPTION**

Provide training for the installation, operation and maintenance of the fiber-optic communications cable, fiber-optic transceivers, interconnect centers, splice trays and other related fiber-optic equipment in accordance with the plans and specifications.

**7.2. MATERIALS**

Provide training to properly install, operate, maintain, diagnose and repair each piece of equipment associated with the fiber-optic system. Provide approved manufacturer’s representatives or other qualified personnel to conduct training courses. Provide training for a minimum of fifteen Department personnel.

Before beginning the training course, submit detailed course curricula, draft manuals, and handouts, and resumes of the instructors for review and approval. The Engineer may request modification of the material and request courses desired by the Department.

Conduct all training courses at a location provided by the Department within the Division and at a time mutually agreed upon, but not later than the start of fiber-optic cable testing. Provide training material, manuals, and other handouts to serve not only as subject guidance, but also as quick reference for use by the students. Deliver course material in reproducible form immediately following the course.

**TIP Number****County Name**

Signals &amp; Intelligent Transportation Systems

Record each training course onto DVD(s) and deliver to the Engineer.

Provide instruction on basic fiber-optic theories and principals as well as the installation, operation, maintenance, identification, detection, and correction of malfunctions in fiber-optic communications cable and related hardware. Include field level troubleshooting as an integral part of the training.

Provide training for the fiber-optic system for the following categories and for the minimum number of hours shown:

**COURSE OUTLINES (L = Lecture; D = Demonstration; H = Hands-on by Student)****TRANSCEIVER****DAY 1 (4 Hours)**

Safety - (L)

Introduction to transceivers - (L)

Review of Maintenance Manual - (L)

Review of Operations Manual - (L)

Question and answer session

**FIBER-OPTIC CABLE SYSTEM****DAY 1 (8 Hours)**

Safety - (L)

Introduction to fiber optics, theory, and principals - (L)

Fiber and cable types -(L, H)

National Electrical Code considerations - (L, H)

plenum and riser type cable

out door cable, etc.

Introduction to terminating hardware, end equipment, and applications - (L, D, H)

connectors (ST, SC, etc.)

splice enclosure, splice trays, and connector panels

cable placement techniques

Question and answer session

**DAY 2 (8 Hours)**

Cable handling and preparation (sheath removal, grip installation, etc.) - (L, D, H)

Splicing and terminating methods - (L, D, H)

    mechanical splicing using various techniques

    fusion splicing

    field termination of connectors types

Introduction to cable plant testing procedures - (L, D, H)

    proper usage of optical light generator and power meter

    optical time domain reflectometer usage

Class project (build working system using cables/connectors made by attendees) - (L, D, H)

Question and answer session

**DAY 3 (4 Hours)**

Class project -- Testing and troubleshooting -- (L, D, H)

Cable system maintenance and restoration -- (L)

Question and answer session

**7.3. MEASUREMENT AND PAYMENT**

Lump sum for fiber-optic training with training packages completed and accepted.

Payment will be made under:

Fiber-optic Training ..... Lump Sum

**8. SPLICE CABINET (FIBER OPTICS)**

**8.1. DESCRIPTION**

Furnish and install splice cabinets and all necessary hardware in accordance with the plans and specifications for the purpose of splicing and terminating fiber-optic cable.

**8.2. MATERIALS**

Furnish NEMA Type 4 splice cabinets of sufficient size to accommodate the fiber-optic interconnect center. Provide sufficient size so that the equipment installed will not occupy more than 60 percent of the total cabinet volume.

**8.3. CONSTRUCTION METHODS**

**A. General:**

Locate cabinets so as not to obstruct sight distance of vehicles turning on red.

**B. Pole Mounted:**

Install pole-mounted splice cabinets. Install cabinets approximately five feet from the ground line to the top of the cabinet. Secure the cabinet to the pole using an approved installation method.

**C. Base Mounted:**

Install base mounted cabinets as shown on the plans and as approved by the Engineer. Refer to Section 1750 - Signal Cabinet Foundations of the *Standard Specifications* for installation requirements for the foundations. The following exceptions are made:

- Install only the required number of conduits as shown on the plans plus one additional spare stub out conduit.
- Do not provide a 24-inch working area on the backside of the cabinet. Provide only a 24-inch working area measured from the front of the cabinet and 3 inch lip measured from the sides and back of the cabinet.
- All other requirements apply.

**8.4. MEASUREMENT AND PAYMENT**

Actual number of fiber-optic splice cabinets (pole mounted) furnished, installed, and accepted.

Actual number of fiber-optic splice cabinets (base mounted) furnished, installed, and accepted.

No measurement will be made for the cabinet foundation as it will be covered under Section 1750 – Signal Cabinet Foundations of the *Standard Specifications*.

Payment will be made under:

Fiber-optic Splice Cabinet ( \_\_\_\_\_ ) ..... Each

**9. SOLAR POWER, 900 MHZ SPREAD SPECTRUM RADIO**

**9.1. DESCRIPTION**

Furnish an operational Solar Power, 900MHz Spread Spectrum Radio System installed in a NEMA Type 3R enclosure for pole mounting.

Furnish material and workmanship conforming to the *National Electrical Code* (NEC), the *National Electrical Safety Code* (NESC), Underwriter’s Laboratories (UL) or a third-party listing agency accredited by the North Carolina Department of Insurance, and all local safety codes in effect on the date of advertisement. Comply with all regulations and codes imposed by the owner of affected utility poles.

**9.2.MATERIALS**

**A. 900MHz Wireless Radio System:**

Furnish a 900 MHz Radio that complies with Section 1098-18 (B) of the 2012 Standard Specifications for Roads and Structures.

Furnish 8.5 dB or 13 dB gain Directional Antenna (Yagi Antenna) that complies with Section 1098-18 (D) of the 2012 Standard Specifications for Roads and Structures.

Furnish 3dB or 6 dB Omni Directional Antenna that complies with Section 1098-18 (E) of the 2012 Standard Specifications for Roads and Structures.

**TIP Number****County Name**

Signals & Intelligent Transportation Systems

Furnish Antenna Mounting Hardware Kits that comply with Section 1098-18 (F) of the 2012 Standard Specifications for Roads and Structures.

Furnish 400 Series Coaxial Cable that complies with Section 1098-18 (G) of the 2012 Standard Specifications for Roads and Structures.

Furnish Standard N-Type Connectors that comply with Section 1098-18 (H) of the 2012 Standard Specifications for Roads and Structures.

Furnish Coaxial Cable Shield Grounding and Weatherproofing Kits that comply with Section 1098-18 (I) of the 2012 Standard Specifications for Roads and Structures.

Furnish Lightning Arrestors that comply with Section 1098-18 (J) of the 2012 Standard Specifications for Roads and Structures.

Furnish Coaxial Cable – Power Divider (Splitter) that complies with Section 1098-18 (K) of the 2012 Standard Specifications for Roads and Structures.

Furnish 1 inch and 2 inch Rigid Metallic Conduit that complies with Section 1091-3 (B) of the 2012 Standard Specifications for Roads and Structures.

Furnish 1 inch clamp-on aluminum weatherheads and 1 1/2 inch heat shrink tubing that complies with Section 1098-4 of the 2012 Standard Specifications for Roads and Structures.

**B. Solar Powered Assembly:****B.1 General:**

Furnish a Solar Power Assembly consisting of the following:

- Solar Array
- Solar Charge Controller
- Battery(ies)
- NEMA 3R Equipment Cabinet

Ensure that DC disconnects are supplied between the Solar Array and the Solar Charge Controller, and between the Solar Charge Controller and the Battery(ies), and between the Battery(ies) and any other equipment.

**B.2 Solar Power System Design Requirements:**

Provide to the Engineer for Approval, a submittal package with Engineering Calculations consisting of, as a minimum, schematic drawing, technical data sheets, and supporting documentation. Ensure the documentation demonstrates, in theory, that the battery(ies) will provide for continuous operation for a minimum of ten (10) consecutive days with no additional charging under the following conditions:

- a) Fully powering the Wireless Repeater Radio operating 24 hours a day with 50% of that time being in a standby (sleep) mode; and 50% of the time being in operational mode.

Provide drawings showing dimension, location of required equipment, cabinet electrical diagrams, part numbers and descriptions of required equipment and accessories to the Engineer.

**B.3 Solar Array:**

Furnish solar modules made in North America and have a minimum 20 year factory warranty. The solar array should have a minimum peak output of 85 Watts. Solar modules must be UL listed, FM Class I, Div II, Group C&D approved. For the solar array, power wiring should be 10-2, stranded copper, double insulated, sunlight resistant, 600V 90C rated cable. Ensure the solar array mount is manufactured from an aluminum alloy or stainless steel and is capable of withstanding 140 mph winds.

**B.4 Solar Charger Controller:**

Furnish a Pulse Width Modulation (PWM) solar charge controller that is UL listed, with a minimum 20A solid state, low voltage disconnect. The solar charge controller must be sealed with internal temperature compensation, lightning protection, reverse polarity protection, and LED indicators. Furnish controllers with the capability of 3 functions: battery charging, load control, and diversion regulation. Controllers must be furnished with fully adjustable DIP switches and RS-232 communications port to adjust the unit's operational modes. Ensure the solar charge controller is listed as a FM Class I, Div. II, Groups ABCD device and has the CE mark.

**B.5 Batteries:**

Provide a 12V gel electrolyte, non-spillable, maintenance free battery. The battery(ies) should be able to provide power for 10 days without being charged by the Solar Array. Furnish battery(ies) with a minimum operating temperature of -76° F to 140°F.

**B.6 NEMA 3R Equipment Cabinet:**

Provide a NEMA 3R type Equipment Cabinet enclosure that is of a pole mount design, with compartments to house the battery(ies) and electronic components separately. Ensure that the equipment installed inside the cabinet does not occupy more than 60% of the total cabinet volume.

Ensure that the battery compartment and the electronic equipment compartments are ventilated with a screen and louvered vents. Equip vents with standard-size, replaceable furnace type vent filters. Size the filter tray to adequately house and secure the filter in place. Ensure there are no obstructions on the interior face of the door to interfere with easy removal and replacement of filter.

Provide an enclosure that is fabricated with unpainted, natural, aluminum that complies with Section 7 of NEMA TS-2-1998. Ensure the equipment cabinet enclosure shell is fitted with one (1) Corbin Number 2 Key, lifting handles, exhaust ports. Provide all necessary hardware to mount the enclosure securely to the pole. Provide hardware that is stainless steel or a Department approved non-corrosive alternate including the hinges and lifting handle.

Provide roof with slope (from front to back) at a minimum ratio of 1” drop per 2 feet. Ensure roof is flush with front of the door. Ensure each exterior cabinet plane surface is constructed of a single sheet of seamless aluminum.

Provide a handle and three point latching mechanism designed to be disassembled using hand tools. Provide a shaft connecting the latching plate to the door handle by passing through the door within a bushing, bearing, or equivalent device. Provide a latching plate at least 1/8 inch thick and that mates securely with the lock bolt. Provide a lock bolt with a flat end (no bevel) and that has at least 1/4 inch of length in contact with the latching plate.

Ensure that the handle and lock are positioned so that the lock does not lie in the path of the rotating handle as the door is unlatched and that the handle points down in the latched position.

Provide a main door opening that encompasses the full frontal area of the cabinet shell. Ensure that the cabinet shell is sturdy and does not exhibit noticeable flexing, bending or distortion under normal conditions, except that a minor amount of flexing is permitted in the main door when the cabinet is open. In such case, the flexing must not result in permanent deformation of the door.

A police panel door is not required for these cabinets.

Equipment in the equipment cabinet enclosure will be shelf mounted. Provide one equipment shelf in the cabinet that extends the practical width of the cabinet. Ensure that the shelf can be moved up and down within the cabinet. Do not locate permanently mounted equipment in such a way that will restrict access to terminals. Ensure all components are arranged for easy access during servicing. When modular in construction, provide guides and positive connection devices to ensure proper pin alignment and connection.

Arrange equipment and terminals within the cabinet so that they will not interfere with the entrance, tracing and connection of conductors or other cables. Ensure all incoming and outgoing conductors are connected to terminal blocks. Ensure all field terminals are readily accessible without having to remove equipment to gain access. Ensure terminals are not located on the underside of shelf or at any other place where they are not readily visible or where they may present a hazard to personnel who might inadvertently touch them.

Provide terminal blocks that are made of electrical grade thermoplastic or thermosetting plastic. Ensure each terminal block is of closed back design and has recessed-screw terminals with molded barriers between terminals. Ensure each terminal consists of two terminal screws with removable shorting bar between them. Ensure all terminal blocks and terminals are labeled with their intended functions. Provide labels that are visible and easy to read when the terminal blocks are wired.

### **9.3.CONSTRUCTION METHODS**

#### **A. Antenna Mounting:**

The Engineer will approve final locations of any solar powered radio systems. Install the antenna, antenna mounting hardware, coaxial cable, power divider, antenna splitter cable and

additional antenna at locations where it is determined that a dual antenna configuration is necessary to accommodate communications in multiple directions.

Install antenna in accordance with the antenna manufacturer's recommendations. Secure the antenna mounting hardware to the pole and route the coaxial cable such that no strain is placed on the N-Type Male coaxial connectors.

Install the coaxial cable shield grounding system by removing the outer jacket of the coaxial cable without damaging the cable shield. Install the shield grounding system following the cable manufacturer's recommendations. Install and weatherproof the connection using the appropriate weatherproofing materials and following the manufacturer's recommendations. On wood poles, secure the #6 AWG grounding lead cable to the pole ground using split bolt or compression type fitting or an Engineer approved method. On metal poles, secure the #6 AWG grounding lead cable to the pole using an Engineer approved method.

Install the coaxial cable in a 1 1/2 inch riser with heat shrink tubing for connecting into the equipment cabinet. Do not exceed the 1-inch bend radius of the coaxial cable as it traverses from the cabinet to the antenna assembly. Connect the lightning arrestor to the coaxial cable in the equipment cabinet. Properly ground and secure the arrestor in the cabinet. Permanently label all cables entering the cabinet.

Place a copy of all manufacturer equipment specifications and instruction and maintenance manuals in the equipment cabinet.

**B. Solar Power Assembly:**

Do not obstruct the sight distance of vehicles when locating and installing the equipment cabinet. Mount equipment cabinet so that the height to the middle of the cabinet is 4 feet above grade. Secure the cabinet to the pole using 3/4" stainless steel straps or a method approved by the Engineer.

Ensure that the equipment cabinet along with solar array(s) and its mounting hardware are capable of surviving sustains winds of 140 MPH. Ensure the solar array(s) does not obstruct the view of traffic and that the array(s) are arranged for optimal sunlight exposure for charging of the battery(ies).

Run field wiring from the solar power array(s) to the equipment cabinet through 1 inch riser with weatherhead and make connections inside the equipment cabinets as required. Install separate DC disconnects between the solar array and the solar charger controller and between the solar charger controller and the battery(ies), and between the battery(ies) and any other equipment. Ensure the DC disconnect allows personnel working on the system to safely isolate critical items from each other while performing maintenance and trouble shooting. Ensure that all wiring including grounding of



the solar photovoltaic system meets the requirements of Article 690 of the National Electric Code (NEC) and these project special provisions.

To protect against high voltage power surges, furnish and install one grounding electrode at the equipment cabinet.

Terminate all wires using spade connectors under binding screws on terminal blocks. Label all terminal blocks and terminals for easy identification. Label all wires and harnesses for easy identification. Neatly secure all wiring and harness inside the cabinet in a method approved by the Engineer.

Provide and leave all data interface cables, installation manuals, and specifications and materials used to program any equipment in the Equipment Cabinet. Program all equipment for operation.

**9.4. MEASUREMENT AND PAYMENT**

Actual number of Solar Power, 900MHz Spread Spectrum Radio Systems furnished, installed and accepted.

This item includes the appropriate sized Solar Power Assembly (Solar Array, Solar Charger Controller, Battery, NEMA 3R equipment cabinet), 1 inch riser with weatherhead, 1 1/2 inch riser with heat shrink tubing, antenna(s), radio, data interface cable/serial cable, coaxial cable, lightning arrestor, radio frequency signal jumper, coaxial cable power divider (Splitter), coaxial cable connectors, coaxial cable shield grounding system with weatherproofing, labeling and any integration, installation materials and configuration software necessary to complete this work, including the Solar Power System Design Calculations and warranties, will be incidental.

Payment will be made under:

Solar Power, 900MHz Spread Spectrum Radio ..... Each

**10. MODIFY SPREAD SPECTRUM WIRELESS RADIO**

**10.1. DESCRIPTION**

Make modifications to existing Spread Spectrum Radio installations.

**10.2. MATERIALS**

Material, equipment, and hardware furnished under this section shall be pre-approved on the Departments' QPL.

Reference Article 1098-18 "Spread Spectrum Wireless Radio" of the Standard Specifications for Roads and Structures.

**10.3. CONSTRUCTION METHODS**

This item of work involves making modifications to existing wireless installations which include relocating an existing radio from an existing cabinet to a new cabinet, and/or relocating existing components of the radio system from an existing pole to new poles (wood poles, metal strain poles,

metal poles with mast arms, etc.). This item of work includes, but may not be limited to, the following:

- Relocating existing radio from an existing cabinet to a new cabinet
- Relocating or installing new Coaxial Cable
- Furnishing and installing new N-Type Connectors
- Furnishing new Coaxial Cable and Shield Grounding Kits
- Relocating Antenna Mounting Hardware
- Relocating Antennas

This item of work may also involve converting an existing standalone radio site to a repeater site. This item of work includes, but may not be limited to, the following:

- Furnishing and installing new antenna(s)
- Furnishing and installing new antenna mounting hardware kits
- Furnishing and installing new 6 foot coaxial cable jumpers with N-Type Connectors
- Furnishing and installing new coaxial cable – power divider (Splitters)

**10.4. MEASUREMENT AND PAYMENT**

*Modify Radio Installation* will be measured as the actual number of modified radio installations that are modified and accepted.

This item includes relocating the radio, and furnishing and/or relocating and installing coaxial cable, N-Type Connectors, coaxial cable shield grounding kits, antenna mounting hardware, antennas, coaxial cable and power dividers. This item of work may also involve furnishing and installing new decals and furnishing or relocating signs. This item of work may also involve re-programming the radio.

Payment for new risers will be covered separately.

Payment will be made under:

Modify Radio Installation..... Each

**11. TRAFFIC SIGNAL SUPPORTS**

**11.1. METAL TRAFFIC SIGNAL SUPPORTS – ALL POLES**

**A. General:**

Furnish and install metal strain poles and metal poles with mast arms, grounding systems, and all necessary hardware. The work covered by this special provision includes requirements for the design, fabrication, and installation of both standard and custom/site specifically designed metal traffic signal supports and associated foundations.

Provide metal traffic signal support systems that contain no guy assemblies, struts, or stay braces. Provide designs of completed assemblies with hardware that equals or exceeds AASHTO *Standard Specifications for Structural Supports for Highway Signs, Luminaires and Traffic Signals*

**TIP Number****County Name**

Signals &amp; Intelligent Transportation Systems

5th Edition, 2009 (hereafter called 5th Edition AASHTO), including the latest interim specifications. Provide assemblies with a round or near-round (18 sides or more) cross-section, or a multi sided cross section with no less than six sides. The sides may be straight, convex, or concave.

Pole heights shown on signal plans are estimated from available data for bid purposes. Prior to furnishing metal signal poles, use field measurements and adjusted cross-sections to determine whether pole heights are sufficient to obtain required clearances. If pole heights are not sufficient, the Contractor should immediately notify the Engineer of the required revised pole heights.

Ensure that metal signal poles permit cables to be installed inside poles and any required mast arms. For holes in the poles and arms used to accommodate cables, provide full-circumference grommets. Arm flange plate wire access holes should be deburred, non grommited, and oversized to fit around the 2” diameter grommited shaft flange plate wire access hole.

After fabrication, have steel poles, required mast arms, and all parts used in the assembly hot-dip galvanized per section 1076. Design structural assemblies with weep holes large enough and properly located to drain molten zinc during galvanization process. Provide hot-dip galvanizing on structures that meets or exceeds ASTM Standard A-123. Provide galvanizing on hardware that meets or exceeds ASTM Standard A-153. Ensure that threaded material is brushed and retapped as necessary after galvanizing. Perform repair of damaged galvanizing that complies with the following:

Repair of Galvanizing ..... Article 1076-7

Standard Drawings for Metal Poles are available that supplement these project special provisions. These drawings are located on the Department’s website:

<https://connect.ncdot.gov/resources/safety/pages/ITS-Design-Resources.aspx>

Comply with article 1098-1B of the *2012 STANDARD SPECIFICATIONS FOR ROADS & STRUCTURES*, hereinafter referred to as the *Standard Specifications* for submittal requirements. Furnish shop drawings for approval. Provide the copies of detailed shop drawings for each type of structure as summarized below. Ensure that shop drawings include material specifications for each component and identify welds by type and size on the drawing details, not in table format. **Do not release structures for fabrication until shop drawings have been approved by NCDOT.** Provide an itemized bill of materials for all structural components and associated connecting hardware on the drawings.

Comply with article 1098-1A of the *Standard Specifications* for Qualified Products List (QPL) submittals. All shop drawings must include project location description, signal inventory number(s) and a project number or work order number on the drawings.

Summary of information required for metal pole review submittal:

| <b>Item</b>                                  | <b>Hardcopy Submittal</b> | <b>Electronic Submittal</b> | <b>Comments / Special Instructions</b>   |
|--|---------------------------|-----------------------------|--|
| Sealed, Approved Signal Plan/Loading Diagram | 1                         | 1                           | All structure design information needs to reflect the latest approved signal plans |
| Custom Pole Shop                             | 4 sets                    | 1 set                       | Submit drawings on 11” x 17” format media  |

|  |        |       |  |
|--|--------|-------|--|
| Drawings                                   |        |       | Show NCDOT inventory number(s) in or above the title block   |
| Standard Pole Shop Drawings (from the QPL) | 4 sets | 1 set | Submit drawings on 11" x 17" format media<br>Show NCDOT inventory number(s) in or above the title block  |
| Structure Calculations                     | 1 set  | 1 set | Not required for Standard QPL Poles  |
| Standard Pole Foundation Drawings          | 1 set  | 1 set | Submit drawings on 11" x 17" format media.<br>Submit a completed Standard Foundation Selection form for each pole using foundation table on Metal Pole Drawing M-8.                      |
| Custom Foundation Drawings                 | 4 sets | 1 set | Submit drawings on 11" x 17" format media. If QPL Poles are used, include the corresponding QPL pole shop drawings with this submittal.  |
| Foundation Calculations                    | 1      | 1     | <b>Submit L-Pile calculations per Section 11.4 of this specification.</b><br>Not required for Standard QPL Poles   |
| Soil Boring Logs and Report                | 1      | 1     | Report should include a location plan and a soil classification report including soil capacity, water level, hammer efficiency, soil bearing pressure, soil density, etc. for each pole. |

**NOTE** – All shop drawings and custom foundation design drawings must be sealed by a Professional Engineer licensed in the state of North Carolina. All geotechnical information must be sealed by either a Professional Engineer or geologist licensed in the state of North Carolina. Include a title block and revision block on the shop drawings and foundation drawings showing the NCDOT inventory number.

**Shop drawings and foundation drawings may be submitted together or separately for approval. However, shop drawings must be approved before foundations can be reviewed.** Foundation designs will be returned without review if the associated shop drawing has not been approved. Incomplete submittals will be returned without review.

**B. Materials:**

Fabricate metal pole and arm shaft from coil or plate steel to meet the requirements of ASTM A 595 Grade A tubes. For structural steel shapes, plates and bars use A572 Gr 50 min or ASTM A709 Gr 50 min. Provide pole and arm shafts that are round in cross section or multisided tubular shapes and have a uniform linear taper of 0.14 in/ft. Construct shafts from one piece of single ply plate or coil so there are no circumferential weld splices. Galvanize in accordance with AASHTO M 111 or an approved equivalent.

Use the submerged arc process or other NCDOT previously approved process suitable for pole shaft and arms to continuously weld pole shafts and arm shafts along their entire length. The longitudinal seam weld will be finished flush to the outside contour of the base metal. Ensure shafts have no circumferential welds except at the lower end joining the shaft to the pole base and arm

base. Provide welding that conforms to Article 1072-18 of the *Standard Specifications*, except that no field welding on any part of the pole will be permitted unless approved by a qualified engineer.

Refer to Metal Pole Standard Drawing Sheets M2 through M5 for fabrication details. Fabricate anchor bases from plate steel meeting, as a minimum, the requirements of ASTM A 36M or cast steel meeting the requirements of ASTM A 27M Grade 485-250, AASHTO M270 Gr 36 or an approved equivalent. Conform to the applicable bolt pattern and orientation as shown on Metal Pole Standard Drawing Sheet M2.

Ensure all hardware is galvanized steel or stainless steel. The Contractor is responsible for ensuring that the designer/fabricator specifies connecting hardware and/or materials that do not create a dissimilar metal corrosive reaction.

Provide a minimum of four (4) 1-1/2" diameter high strength bolts for connection between arm plate and pole plate. Increase number of bolts to six (6) 1-1/2" diameter high strength bolts when arm lengths are greater than 50'-0" long.

Unless otherwise required by the design, ensure each anchor rod is 2" diameter and 60" length. Provide 10" minimum thread projection at the top of the rod, and 8" minimum at the bottom of the rod. Use anchor rod assembly and drilled pier foundation materials that meet the *Foundations and Anchor Rod Assemblies for Metal Poles* provision.

For each structural bolt and other steel hardware, hot dip galvanizing shall conform to the requirements of AASHTO M 232 (ASTM A 153). Ensure end caps for poles or mast arms are constructed of cast aluminum conforming to Aluminum Alloy 356.0F.

Provide a circular anchor bolt lock plate that will be secured to the anchor bolts at the embedded end with 2 washers and 2 nuts. Provide a base plate template that matches the bolt circle diameter of the anchor bolt lock plate. Construct plates and templates from 1/4" minimum thick steel with a minimum width of 4". Galvanizing is not required for both plates.

Provide 4 heavy hex nuts and 4 flat washers for each anchor bolt. For nuts, use AASHTO M291 grade 2H, DH, or DH3 or equivalent material. For flat washers, use AASHTO M293 or equivalent material.

### **C. Construction Methods:**

Erect signal support poles only after concrete has attained a minimum allowable compressive strength of 3000 psi. Install anchor rod assemblies in accordance with the *Foundations and Anchor Rod Assemblies for Metal Poles* provision.

For further construction methods, see construction methods for Metal Strain Pole, or Metal Pole with Mast Arm.

Connect poles to grounding electrodes and bond them to the electrical service grounding electrodes.

For holes in the poles used to accommodate cables, install grommets before wiring pole or arm. Do not cut or split grommets.

Attach the terminal compartment cover to the pole by a sturdy chain or cable. Ensure the chain or cable is long enough to permit the cover to hang clear of the compartment opening when the cover is removed, and is strong enough to prevent vandalism. Ensure the chain or cable will not interfere with service to the cables in the pole base.

Attach cap to pole with a sturdy chain or cable. Ensure the chain or cable is long enough to permit the cap to hang clear of the opening when the cap is removed.

Perform repair of damaged galvanizing that complies with the *Standard Specifications*, Article 1076-67 “Repair of Galvanizing.”

Install galvanized wire mesh around the perimeter of the base plate to cover the gap between the base plate and top of foundation for debris and pest control.

Install a ¼” thick plate for concrete foundation tag to include: concrete grade, depth, diameter, and reinforcement sizes of the installed foundation.

## **11.2. METAL STRAIN POLE**

### **A. Materials:**

Provide either steel or aluminum poles as indicated on the plans.

#### **Comply with the following for Aluminum Poles:**

- Have poles fabricated from Aluminum Association Alloy 6061-T6, 6063-T6, or approved equivalent. The structural requirement does not pertain to castings that are decorative only.
- Have shafts tapered by spinning and cold-working a seamless extruded tube of the aluminum alloy.
- Have shafts with no circumferential welds except at the lower end joining the shaft to the base.
- Ensure aluminum poles are properly protected from damage prior to shipment.
- Have bases of the shaft fabricated in accordance with the Aluminum Association Alloy 356.0-T6, and of adequate strength, shape and size, and capable of withstanding the design load of the shaft.
- Have aluminum surfaces in contact with concrete or dissimilar metal coated with bituminous paint.

#### **Comply with the following for Steel Poles:**

- Have shafts of the tapered tubular type and fabricated of steel conforming to ASTM A-595 Grade A or an approved equivalent.
- Have galvanization in accordance with AASHTO M 111 or an approved equivalent.
- Have shafts that are continuously welded for the entire length by the submerged arc process, and with exposed welds ground or rolled smooth and flush with the base metal. Provide welding that conforms to Article 1072-18 per *Standard Specification* except that no field welding on any part of the pole will be permitted.
- Have anchor bases for steel poles fabricated from plate steel meeting as a minimum the requirements of ASTM A 36M or cast steel meeting the requirements of ASTM A 27M Grade 485-250 or an approved equivalent.

For each strain pole, provide 2 messenger cable (span wire) clamps and associated hardware for attachment of support cable of the messenger cable suspension. Ensure that diameter of the clamp is

appropriate to its location on the pole and that the diameter of the clamps is appropriately designed to be adjustable from 1'-6" below the top, down to 6'-6" below the top of the pole. Do not attach more than one support cable to a messenger cable clamp.

For strain poles, provide a minimum of three (3) 2 inch (50 mm) holes equipped with an associated coupling and weatherhead on the messenger cable load side of the pole to accommodate passage of signal cables from inside the pole to the suspension. Provide galvanized threaded plugs for all unused couplings at pole entrance points. Refer to Metal Pole Standard Drawing Sheet M3 for fabrication details.

Provide a grounding lug(s) in the approximate vicinity of the messenger cable clamp for bonding and grounding messenger cable. Lugs must accept #4 or #6 AWG wire to bond messenger cables to the pole in order to provide an effective ground fault circuit path. Refer to Metal Pole Standard Drawing Sheet M6 for construction details.

Have poles permanently stamped above the hand holes with the identification tag details as shown on Metal Pole Standard Drawing Sheet M2.

Provide liquid tight flexible metal conduit (Type LFMC), liquid tight flexible nonmetallic conduit (Type LFNC), high density polyethylene conduit (Type HDPE), or approved equivalent to isolate conductors feeding luminaires.

Fabricate poles from a single piece of steel or aluminum with single line seam weld with no transverse butt welds. Fabrication of two ply pole shafts is unacceptable with the exception of fluted shafts. Provide tapers for all shafts that begin at base and that have diameters which decrease uniformly at the rate of not more than 0.14 inch per foot (11.7 millimeters per meter) of length.

Ensure that allowable pole deflection does not exceed that allowed per 5<sup>th</sup> Edition AASHTO. For messenger cable poles (with primarily transverse loads), ensure that maximum deflection at the top of the pole does not exceed 2.5 percent of the pole height. For mast arm poles (with primarily moment loads), ensure that maximum angular rotation of the top of the pole does not exceed 1° 40'.

Provide four anchor nuts and four washers for each anchor bolt. Ensure that anchor bolts have required diameters, lengths, and positions, and will develop strengths comparable to their respective poles.

Provide a terminal compartment with cover and screws in each pole that encompasses the hand hole and contains a 12-terminal barrier type terminal block. Provide two terminal screws with a removable shorting bar between them for each termination. Furnish terminal compartment covers attached to the pole by a sturdy chain or cable approved by the Engineer. Ensure that the chain or cable is long enough to permit the cover to hang clear of the compartment opening when the cover is removed, and is strong enough to prevent vandals from being able to disconnect the cover from the pole. Ensure that the chain or cable will not interfere with service to the cables in the pole base.

Install grounding lugs that will accept #4 or #6 AWG wire to electrically bond messenger cables to the pole. Refer to Metal Pole Standard Drawing Sheet M6 for construction details.

For each pole, provide a 1/2 inch minimum thread diameter, coarse thread stud and nut for grounding which will accommodate #6 AWG ground wire. Ensure that the lug is electrically bonded to the pole and is conveniently located inside the pole at the hand hole.

Provide a removable pole cap with stainless steel attachment screws for the top of each pole. Ensure that the cap is cast aluminum conforming to Aluminum Association Alloy 356.0F. Furnish

cap attached to the pole with a sturdy chain or cable approved by the Engineer. Ensure that the chain or cable is long enough to permit the cap to hang clear of the pole-top opening when the cap is removed.

When required by the plans, furnish couplings 42 inches above the bottom of the base for mounting of pedestrian pushbuttons. Provide mounting points consisting of 1-1/2 inch internally threaded half-couplings that comply with the NEC and that are mounted within the poles. Ensure that couplings are essentially flush with the outside surfaces of the poles and are installed before any required galvanizing. Provide a threaded plug in each mounting point. Ensure that the surface of the plug is essentially flush with the outer end of the mounting point when installed and has a recessed hole to accommodate a standard wrench.

**B. Construction Methods:**

Install metal poles, hardware, and fittings as shown on the manufacturer's installation drawings. Install metal poles so that when the pole is fully loaded it is within 2 degrees of vertical. Install poles with the manufacturer's recommended "rake." Use threaded leveling nuts to establish rake if required.

**11.3. METAL POLE WITH MAST ARM**

Provide signal support mast arm assemblies. Comply with the previous Section – Metal Strain Pole – except as noted herein.

Provide pole plates and associated gussets and fittings for attachment of required mast arms. As part of each mast arm attachment, provide a cable passage hole in the pole to allow passage of signal cables from the pole to the arm.

Ensure that allowable mast arm deflection does not exceed that allowed per 5<sup>th</sup> Edition AASHTO. Also when arm is fully loaded, tip of the arm shall not go below the arm attachment point with the pole for all load conditions per 5<sup>th</sup> Edition AASHTO.

Furnish all arm plates and necessary attachment hardware, including bolts and brackets.

Provide two extra bolts for each arm.

Provide grommet holes on the arms to accommodate cables for the signals.

Provide arms with weatherproof connections for attaching to the shaft of the pole.

Provide hardware that is galvanized steel, stainless steel, or corrosive-resistant aluminum.

Provide a removable end cap with stainless steel attachment screws for the end of each mast arm. Ensure that the cap is cast aluminum conforming to Aluminum Association Alloy 356.0F. Furnish cap attached to the arm with a sturdy chain or cable approved by the Engineer. Ensure that the chain or cable is long enough to permit the cap to hang clear of the arm end opening when the cap is removed.

**Comply with the following for Aluminum Arms:**

- Conform to Aluminum Association Alloy 6061-T6, 6063-T6 or approved equivalent.
- Conform to the welding requirements of the aluminum poles.
- Have satin brush finished and furnish individually wrapped.

**Comply with the following for Steel Luminaire Arms:**



## Signals &amp; Intelligent Transportation Systems

- In addition to tapered tube, luminaire arms may be standard weight black steel pipe conforming to ASTM A 53-90a, Type E or Type S, Grade B or an approved equivalent.
- Conform to the welding requirements of the steel poles.
- After all fabricating, cutting, punching, and welding are completed, luminaire arms should be hot-dipped galvanized inside and outside.
- In accordance with the National Electrical Code (NEC) Article 230.2(E), provide identification of the electrical source provider for the luminaire feeder circuit with contact information on a permanent label located in the pole hand hole in the vicinity of the feeder circuit raceway.

**A. Materials:**

Fabrication of two ply pole shafts and arms is unacceptable with the exception of fluted members.

After all fabricating, cutting, punching, and welding are completed, hot-dip galvanize the structure in accordance with the AASHTO M 111 or [an approved](#) equivalent.

**B. Construction Methods:**

Install horizontal-type arms with sufficient manufactured rise to keep arm from deflecting below the arm attachment height.

Attach cap to the mast arm with a sturdy chain or cable. Ensure that the chain or cable is long enough to permit the cap to hang clear of the arm opening when the cap is removed.

For mast arm poles, use full penetration welds with back-up ring at the pole base and at the arm base connection.

**11.4. DRILLED PIER FOUNDATIONS FOR METAL TRAFFIC SIGNAL POLES**

Analysis procedures and formulas shall be based on AASHTO, ACI code and per FHWA manuals. Design methods based on engineering publications or research papers needs to have prior approval from NCDOT. The Department reserves the right to accept or disapprove any method used for the analysis.

Use a Factor of Safety of 1.33 for torsion and 2.0 for bending for the foundation design.

Foundation design for lateral load shall not exceed 1" lateral deflection at top of foundation.

Design all custom foundations to carry the maximum capacity of each metal pole. For standard case strain poles only, if a custom foundation is designed, use the actual moment reactions from the Standard Foundation Selection Table shown on Standard Drawing No. M8.

To prevent design of oversized drilled shafts or other foundation types, do not use mast arm lengths exceeding 50'-0" and refrain from using dual mast arms, when installing new mast arm structures east of US Route 17.

When poor soil conditions are encountered which could create an excessively large foundation design, consideration may be given to allowing an exemption to the maximum capacity design. The contractor must gain approval from the engineer before reducing a foundation's capacity. On projects where poor soil is known to be present, it is advisable that the contractor consider getting foundations approved before releasing poles for fabrication.

Have the contractor notify the engineer if the proposed foundation is to be installed on a slope other than 8H: 1V or flatter.

**A. Description:**

Furnish and install foundations for NCDOT metal poles with all necessary hardware in accordance with the plans and specifications.

Metal Pole Standards have been developed and implemented by NCDOT for use at signalized intersections in North Carolina. If the plans call for a standard pole, then a standard foundation may be selected from the plans. However, the Contractor is not required to use a standard foundation. If the Contractor chooses to design a non-standard site-specific foundation for a standard pole or if the plans call for a non-standard site-specific pole, design the foundation to conform to the applicable provisions in the NCDOT Metal Pole Standards and Section B4 (Non-Standard Foundation Design) below. If non-standard site specific foundations are designed for standard QPL approved strain poles, the foundation designer must use the design moment specified by load case on Metal Pole Standard Drawing Sheet M8. Failure to conform to this requirement will be grounds for rejection of the design.

If the Contractor chooses to design a non-standard foundation for a standard pole and the soil test results indicate a standard foundation is feasible for the site, the Contractor will be paid the cost of the standard foundation (drilled pier and wing wall, if applicable). Any additional costs associated with a non-standard site-specific foundation including additional materials, labor and equipment will be considered incidental to the cost of the standard foundation. All costs for the non-standard foundation design will also be considered incidental to the cost of the standard foundation.

**B. Soil Test and Foundation Determination:**

**1. General:**

Drilled piers are reinforced concrete sections, cast-in-place against in situ, undisturbed material. Drilled piers are of straight shaft type and vertical.

Some standard drilled piers for supporting poles with mast arms may require wing walls to resist torsional rotation. Based upon this provision and the results of the required soil test, a drilled pier length and wing wall requirement may be determined and constructed in accordance with the plans.

For non-standard site-specific poles, the contractor-selected pole fabricator will determine if the addition of wing walls is necessary for the supporting foundations.

**2. Soil Test:**

Perform a soil test at each proposed metal pole location. Complete all required fill placement and excavation at each signal pole location to finished grade before drilling each boring. Soil tests performed that are not in compliance with this requirement may be rejected and will not be paid. Drill one boring to a depth of 26 feet within a 25 foot radius of each proposed foundation.

Perform standard penetration tests (SPT) in accordance with ASTM D 1586 at depths of 1, 2.5, 5, 7.5, 10, 15, 20 and 26 feet. Discontinue the boring if one of the following occurs:

- A total of 100 blows have been applied in any 2 consecutive 6-in. intervals.
- A total of 50 blows have been applied with < 3-in. penetration.

Describe each intersection as the “Intersection of (Route or SR #), (Street Name) and (Route or SR #), (Street Name), \_\_\_\_\_ County, Signal Inventory No. \_\_\_\_\_”. Label borings with “B- N, S, E, W, NE, NW, SE or SW” corresponding to the quadrant location within the intersection. Pole numbers should be made available to the Drill Contractor. Include pole numbers in the boring label if they are available. If they are not available, ensure the boring labels can be cross-referenced to corresponding pole numbers. For each boring, submit a legible (hand written or typed) boring log signed and sealed by a licensed Geologist or Professional Engineer registered in North Carolina. Include on each boring the SPT blow counts and N-values at each depth, depth of the boring, hammer efficiency and a general description of the soil types encountered.

**3. Standard Foundation Determination:**

Use the following method for determining the Design N-value:

$$N_{AVG} = \frac{(N@1' + N@2.5' + \dots + N@Deepest\ Boring\ Depth)}{\text{Total Number of N-values}}$$

$$Y = (N@1')^2 + (N@2.5')^2 + \dots + (N@Deepest\ Boring\ Depth)^2$$

$$Z = (N@1' + N@2.5' + \dots + N@Deepest\ Boring\ Depth)$$

$$N_{STD\ DEV} = \left[ \frac{(\text{Total Number of N-values} \times Y) - Z^2}{(\text{Total Number of N-values}) \times (\text{Total Number of N-values} - 1)} \right]^{0.5}$$

**Design N-value** equals lesser of the following two conditions:

$$N_{AVG} - (N_{STD\ DEV} \times 0.45)$$

*Or*

$$\text{Average of First Four N-Values} = \frac{(N@1' + N@2.5' + N@5' + N@7.5')}{4}$$

*Note: If less than 4 N-values are obtained because of criteria listed in Section 2 above, use average of N-values collected for second condition. Do not include the N-value at the deepest boring depth for above calculations if the boring is discontinued at or before the required boring depth because of criteria listed in Section 2 above. Use N-value of zero for weight of hammer or weight of rod. If N-value is greater than 50, reduce N-value to 50 for calculations.*

If standard NCDOT strain poles are shown on the plans and the Contractor chooses to use standard foundations, determine a drilled pier length, “L,” for each signal pole from the Standard Foundations Chart (sheet M 8) based on the Design N-value and the predominant soil type. For each standard pole location, submit a completed “Metal Pole Standard Foundation Selection Form” signed by the Contractor’s representative. Signature on form is for verification purposes only. Include the Design N-value calculation and resulting drilled pier length, “L,” on each form.

**Signals & Intelligent Transportation Systems**

If non-standard site-specific poles are shown on the plans, submit completed boring logs collected in accordance with Section 2 (Soil Test) above along with pole loading diagrams from the plans to the contractor-selected pole fabricator to assist in the pole and foundation design.

If one of the following occurs, the Standard Foundations Chart shown on the plans may not be used and a non-standard foundation may be required. In such case, contact the Engineer.

- The Design N-value is less than 4.
- The drilled pier length, “L”, determined from the Standard Foundations Chart, is greater than the depth of the corresponding boring.

In the case where a standard foundation cannot be used, the Department will be responsible for the additional cost of the non-standard foundation.

Foundation designs are based on level ground around the traffic signal pole. If the slope around the edge of the drilled pier is steeper than 8:1 (H:V) or the proposed foundation will be less than 10 feet from the top of an embankment slope, the Contractor is responsible for providing slope information to the foundation designer and to the Engineer so it can be considered in the design.

The “Metal Pole Standard Foundation Selection Form” may be found at:

<http://www.ncdot.gov/doh/preconstruct/highway/geotech/formdet/misc/MetalPole.pdf>

If assistance is needed, contact the Engineer.

**4. Non-Standard Foundation Design:**

Design non-standard foundations based upon site-specific soil test information collected in accordance with Section 2 (Soil Test) above. Design drilled piers for side resistance only in accordance with Section 4.6 of the *AASHTO Standard Specifications for Highway Bridges*. Use the computer software LPILE version 5.0 or later manufactured by Ensoft, Inc. to analyze drilled piers. Use the computer software gINT version 8.0 or later manufactured by Bentley Systems, Inc. with the current NCDOT gINT library and data template to produce SPT boring logs. Provide a drilled pier foundation for each pole with a length and diameter that result in a horizontal lateral movement of less than 1 inch at the top of the pier and a horizontal rotational movement of less than 1 inch at the edge of the pier. Contact the Engineer for pole loading diagrams for standard poles to be used for non-standard foundation designs. Submit any non-standard foundation designs including drawings, calculations, and soil boring logs to the Engineer for review and approval before construction.

**C. Drilled Pier Construction:**

Construct drilled pier foundations in accordance with the *Foundations and Anchor Rod Assemblies for Metal Poles* provision.

**11.5. CUSTOM DESIGN OF TRAFFIC SIGNAL SUPPORTS****A. General:**

Design traffic signal supports with foundations consisting of metal strain poles or metal poles with mast arms.

The lengths of the metal signal poles shown on the plans are estimated from available data for bid purposes. Determine the actual length of each pole from field measurements and adjusted cross-sections. Furnish the revised pole heights to the Engineer. Use all other dimensional requirements shown on the plans.

Ensure each pole includes an identification tag with information and location positions as defined on Metal Pole Standard Drawing Sheets M2, M3 and M4. All pole shaft tags must include the NCDOT Inventory number followed by the pole number shown on the traffic signal or ITS (non-signalized locations) plan.

Design all traffic signal support structures using the following 5th Edition AASHTO specifications:

- Design for a 50 year service life as recommended by Table 3-3.
- Use the wind pressure map developed from 3-second gust speeds, as provided in Article 3.8.
- Ensure signal support structures include natural wind gust loading and truck-induced gust loading in the fatigue design, as provided for in Articles 11.7.3 and 11.7.4, respectively. Designs need not consider periodic galloping forces.
- Assume the natural wind gust speed in North Carolina is 11.2 mph. For natural wind fatigue stress calculations, utilize a drag coefficient ( $C_d$ ) computed for 11.2 mph wind velocity and not the basic wind speed velocity.
- Design for Category II fatigue, as provided for in Article 11.6, unless otherwise specified.
- Calculate all stresses using applicable equations from Section 5. The Maximum allowable stress ratios for all signal support designs are 0.9.
- Conform to article 10.4.2 and 11.8 for all deflection requirements.

Ensure that the design permits cables to be installed inside poles and mast arms.

Unless otherwise specified by special loading criteria, the computed surface area for ice load on signal heads is:

- 3-section, 12-inch, Surface area: 26.0 ft<sup>2</sup> (17.0 ft<sup>2</sup> without back plate)
- 4-section, 12-inch, Surface area: 32.0 ft<sup>2</sup> (21.0 ft<sup>2</sup> without back plate)
- 5-section, 12-inch, Surface area: 42.0 ft<sup>2</sup> (29.0 ft<sup>2</sup> without back plate)

The ice loading for signal heads defined above includes the additional surface area that back plates will induce. Special loading criteria may be specified in instances where back plates will not be installed on signal heads. Refer to the Loading Schedule on each Metal Pole Loading Diagram for revised signal head surface areas. The pole designer should revise ice loads accordingly in this instance. Careful examination of the plans when this is specified is important as this may impact sizing of the metal support structure and foundation design which could affect proposed bid quotes. All maximum stress ratios of 0.9 still apply.

Assume the combined minimum weight of a messenger cable bundle (including messenger cable, signal cable and detector lead-in cables) is 1.3 lbs/ft. Assume the combined minimum diameter of this cable bundle is 1.3 inches.

Ensure that designs provide a removable pole cap with stainless steel attachment screws for each pole top and mast arm end.

## **B. Metal Poles:**

Submit design drawings for approval including pre-approved QPL pole drawings. Show all the necessary details and calculations for the metal poles including the foundation and connections. Include signal inventory number on design drawings. Include as part of the design calculations the

ASTM specification numbers for the materials to be used. Provide the types and sizes of welds on the design drawings. Include a Bill of Materials on design drawings. Ensure design drawings and calculations are signed, dated, and sealed by the responsible professional engineer licensed in the state of North Carolina. Immediately bring to the attention of the Engineer any structural deficiency that becomes apparent in any assembly or member of any assembly as a result of the design requirements imposed by these specifications, the plans, or the typical drawings. Said Professional Engineer is wholly responsible for the design of all poles and arms. Review and acceptance of these designs by the Department does not relieve the said Professional Engineer of his responsibility. Do not fabricate the assemblies until receipt of the Department's approval of the design drawings.

For mast arm poles, provide designs with provisions for pole plates and associated gussets and fittings for mast arm attachment. As part of each mast arm attachment, provide a grommeted 2" diameter hole on the shaft side of the connection to allow passage of the signal cables from the pole to the arm.

Where ice is present, assume wind loads as shown in Figure 3-5 of the 5th Edition AASHTO Specification for Group III loading.

For each strain pole, provide two messenger cable clamps and associated hardware to attach the messenger support cable. Ensure that the diameter of the clamps is appropriately designed to be adjustable from 1'-6" inches below the top, down to 6'-6" below the top of the pole. Do not attach more than one messenger support cable to a messenger cable clamp.

Provide a grounding lug(s) in the approximate vicinity of the messenger cable clamp for bonding and grounding messenger cable. Lugs must accept #4 or #6 AWG wire to bond messenger cables to the pole in order to provide an effective ground fault circuit path. Refer to Metal Pole Standard Drawing Sheet M6 for construction details.

Design tapers for all pole shafts that begin at the base with diameters that decrease uniformly at the rate of 0.14 inch per foot of length.

Design a base plate on each pole. The minimum base plate thickness for all poles is determined by the following criteria:

Case 1 Circular or rectangular solid base plate with the upright pole welded to the top surface of base plate with full penetration butt weld, and where no stiffeners are provided. A base plate with a small center hole, which is less than 1/3 of the upright diameter, and located concentrically with the upright pole, may be considered as a solid base plate.

The magnitude of bending moment in the base plate, induced by the anchoring force of each anchor bolt is  $M = (P \times D_1) / 2$ , where

$M$  = bending moment at the critical section of the base plate induced by one anchor bolt

$P$  = anchoring force of each anchor bolt

$D_1$  = horizontal distance between the anchor bolt center and the outer face of the upright, or the difference between the bolt circle radius and the outside radius of the upright

Locate the critical section at the face of the anchor bolt and perpendicular to the bolt circle radius. The overlapped part of two adjacent critical sections is considered ineffective.

Case 2 Circular or rectangular base plate with the upright pole socketed into and attached to the base plate with two lines of fillet weld, and where no stiffeners are provided, or any base plate with a center hole that is larger in diameter than 1/3 of the upright diameter.

The magnitude of bending moment induced by the anchoring force of each anchor bolt is  $M = P \times D_2$ ,

where  $P$  = anchoring force of each anchor bolt

$D_2$  = horizontal distance between the face of the upright and the face of the anchor bolt nut

Locate the critical section at the face of the anchor bolt top nut and perpendicular to the radius of the bolt circle. The overlapped part of two adjacent critical sections is considered ineffective.

If the base plate thickness calculated for Case 2 is less than Case 1, use the thickness calculated for Case 1.

The following additional owner requirements apply concerning pole base plates.

- Ensure that whichever case governs as defined above, the anchor bolt diameter is set to match the base plate thickness. If the minimum diameter required for the anchor bolt exceeds the thickness required for the base plate, set the base plate thickness equal to the required bolt diameter.
- For dual mast arm supports, or for single mast arm supports 50' or greater, use a minimum 8 bolt orientation with 2" diameter anchor bolts, and a 2" thick base plate.
- For all metal poles with mast arms, use a full penetration groove weld with a backing ring to connect the pole upright component to the base. Refer to Metal Pole Standard Drawing Sheet M4.

Ensure that designs have anchor bolt holes with a diameter 1/4 inch larger than the anchor bolt diameters in the base plate.

Ensure that the anchor bolts have the required diameters, lengths, and positions, and will develop strengths comparable to their respective poles.

Provide designs with a 6 x 12-inch hand hole with a reinforcing frame for each pole.

Provide designs with a terminal compartment with cover and screws in each pole that encompasses the hand hole and contains provisions for a 12-terminal barrier type terminal block.

For each pole, provide designs with provisions for a 1/2 inch minimum thread diameter, coarse thread stud and nut for grounding which will accommodate a #6 AWG ground wire. Ensure the lug is electrically bonded to the pole and is conveniently located inside the pole at the hand hole.

When required, design couplings on the pole for mounting pedestrian pushbuttons at a height of 42 inches above the bottom of the base. Provide mounting points consisting of 1-1/2 inch internally threaded half-couplings that comply with the NEC that are mounted within the poles. Ensure the couplings are essentially flush with the outside surfaces of the poles and are installed before any required galvanizing. Provide a threaded plug for each half coupling. Ensure that the surface of the plug is essentially flush with the outer end of the mounting point when installed and has a recessed hole to accommodate a standard wrench.

**C. Mast Arms:**

Design all arm plates and necessary attachment hardware, including bolts and brackets as required by the plans.

Design for grommeted holes on the arms to accommodate the cables for the signals if specified.

Design arms with weatherproof connections for attaching to the shaft of the pole.

Always use a full penetration groove weld with a backing ring to connect the mast arm to the pole. Refer to Metal Pole Standard Drawing Sheet M5.

Capacity of tapped flange plate must be sufficient to develop the full capacity of the connecting bolts. In all cases the flange plate of both arm and shaft must be at least as thick as the arm connecting bolts are in diameter.

**11.6. PROTECTIVE POWDER COATING FOR METAL POLES**

**A. Description:**

Provide protective powder coating over galvanization for all steel metal poles including all necessary hardware for the signalized intersection in accordance with the plans and specifications. The aluminum components only need to be powder coated.

**B. Materials:**

With the exception of Aluminum components, furnish all metal poles with galvanic protection along with a tough and durable powder coating application. Aluminum components shall have a durable powder coating application. Galvanization is not required for aluminum components.

Furnish pole caps that have a low gloss powder finish applied over a hot-dipped galvanized surface. Comply with the applicable provisions of Section 442-10 and 442-12 of the *Standard Specifications*.

**Ensure the selected color for protective coating has been verified and approved by the Engineer prior to fabrication.**

**C. Powder Coating Shop Approval:**

Approve the powder coating shop prior to the application of any powder coating process. Submit all requests, procedures and documents electronically to:

- Mr. Brian Hunter, P.E., Chemical Testing Engineer
- bhunter@ncdot.gov

A) Submit a quality control procedure that the company has established to ensure a quality and durable coating. The quality control procedure shall contain at a minimum the following:

- Qualified / Certified personnel to manage the QC Program and to conduct Quality Control tests
- Qualified / certified coaters
- Source and type of powder
- How the powder will be stored
- Powder application facility (heated or unheated)
- Surface pre-treatment



## Signals &amp; Intelligent Transportation Systems

- Surface preparation including profile
  - Application methods
  - Curing conditions (conventional or infrared)
  - Curing Temperature
  - Adhesion & Holiday Detection
  - Repair Procedure
  - Storage and protection of coated items
  - Shipping and handling (packing, protection, and wrapping)
- B) Submit a powder certification from the manufacturer
- C) Submit the following to the Chemical Testing Engineer a minimum of four weeks prior to coating application.
1. Two test panels of ASTM A36 steel, ¼ or greater in thickness measuring 8 inches by 11 inches using the proposed color of the final coat; a powder coated over galvanized test panel and a powder coated over un-galvanized test panel.
  2. In addition, provide two (2) samples of the same or comparable material and thickness as production pieces. Ensure production piece replicas do not exceed twelve inches (12”) in length and width nor 50 pounds in weight.
  3. Submit all test panels with inspection reports and records according to *Standard Specifications*, Section 442, Section 1072, Section 1076, and Section 1080.
  4. Acceptance of the panels is determined by meeting the requirements of ASTM D-4541 of 800 psi for both galvanized and un-galvanized and production piece test panels.
  5. Send all panels to :  
Materials and Tests Unit  
1801 Blue Ridge Road  
Raleigh, NC 27607  
Attn: Chemical Testing Engineer

**D. Construction Methods:****1. Galvanizing**

Galvanize steel products in accordance with Section 1076 of the *Standard Specifications*. Ensure the fabricator or designated representative(s) that is supplying the components to be galvanized communicates with the galvanizer to indicate that the galvanized pieces will be powder coated to avoid water or chromate quenching.

**2. Surface Preparation**

Comply with manufacturer’s recommended surface coating specifications, Steel Structure Painting Council (SSPC) specifications and applicable articles of Section 442 (Painting Steel Structures) of the *Standard Specifications*. Ensure that surface preparations and treatments are performed and meet the requirements of the above referenced specifications.

Some pole components, specifically steel plates  $\frac{3}{4}$  inches or more in thickness, may need blast cleaning prior to structure assembly to remove impurities and non-metallic foreign materials. Mechanically remove all weld flux after structure is assembled

Degrease and prepare steel structure for zinc coating after assembly using full immersion baths and pickling processes in heat controlled caustic and acid solutions. Rinse and clean structure to remove caustic or acid solutions by immersion in a circulating fresh water bath. Immerse structure in a heat controlled concentrated zinc ammonium chloride flux solution and air dry as a final prep before hot-dip galvanization.

Ensure that the surface preparation is no less than specified by the powder manufacturer's recommendations. Prepare all components to be coated in accordance with SSPC SP-2 (Hand Tool Cleaning) and/or SSPC SP-3 (Power Tool Cleaning). Remove all drainage spikes, high spots, protrusions or other surface defects using hand or power tools. Do not remove the galvanization below the limits set forth in AASHTO M111.

Remove grease, oils, moisture, scale, rust or any other foreign matter prior to powder coating to ensure ideal adhesion and coating performance. Prepare and coat the galvanized surface as soon as possible after the galvanization process.

### **3. Powder Coating Application and Curing**

Prepare galvanized finish for powder coating by brush blasting in accordance with SSPC-SP7. Ensure all threaded components of the structure are protected from damage during blasting process.

Use thermosetting powder resin that meets 5A or 5B classifications of ASTM D3359. Apply powder coating electrostatically. Follow manufacturer's recommended preheating requirements. Ensure the top coat finish is applied uniformly to all surfaces with a dry film thickness of between 3.0 to 5.0 mils. Cure the top coat by heating the structure to manufacturer recommended temperatures at the duration required to ensure complete and uniform bond.

### **4. Quality Control**

Ensure the applicator provides all test reports and documentation and inspects all coated material as outlined in the *Standard Specifications*, Section 442, Section 1072, Section 1076, and Section 1080. Ensure the quality control inspection is kept separate from the production functions.

### **5. Storage, Shipping, and Handling**

Store all powder coated material inside or as directed by the Engineer.

Protect the product from incurring damage during all shipping, handling, and storing activities. Do not store the product directly on the ground or in areas where water may pool; the Engineer determines the effectiveness of all storage, shipping and handling methods.

### **6. Repair of Powder Coated Material**

Repair all damage to the coating by the original method of application as outlined in the coating facility's repair procedure. Ensure all repair areas meet the original requirements for adhesion as stated in this Project Special Provision.

Photograph, document, and report all damages upon delivery to the project site prior to unloading. Provide documented damage notifications to the Engineer or to their

authorized representative so the application firm can be notified. The Engineer has the authority to accept or reject the material as outlined in the *Standard Specifications*.

Submit to the Engineer a repair procedure for damaged coatings which occur during storage, transporting, handling and or installation. Utilize a liquid paint approved by the Department, compatible with the powder applied product. Ensure all repair areas demonstrate an adhesion rating of 400 psi in accordance with ASTM D-4541. Obtain Engineer's acceptance of the final finish.

## **11.7. METAL SIGNAL POLE REMOVALS**

### **A. Description:**

Remove and dispose of existing metal signal poles including mast arms, and remove and dispose of existing foundations, associated anchor bolts, electrical wires and connections.

### **B. Construction Methods:**

#### **5. Foundations:**

Remove and promptly dispose of the metal signal pole foundations including reinforcing steel, electrical wires, and anchor bolts to a minimum depth of two feet below the finished ground elevation. At the Contractor's option, remove the complete foundation.

#### **6. Metal Poles:**

Assume ownership of the metal signal poles, remove the metal signal poles, and promptly transport the metal signal poles from the project. Use methods to remove the metal signal poles and attached traffic signal equipment that will not result in damage to other portions of the project or facility. Repair damages that are a result of the Contractor's actions at no additional cost to the Department.

Transport and properly dispose of the materials.

Backfill and compact disturbed areas to match the finished ground elevation. Seed unpaved areas.

Use methods to remove the foundations that will not result in damage to other portions of the project or facility. Repair damages that are a result of the Contractor's actions at no cost to the Department.

## **11.8. POLE NUMBERING SYSTEM**

### **A. New Poles**

Attach an identification tag to each pole shaft and mast arm section as shown on Metal Pole Standard Drawing Sheet M2 "Typical Fabrication Details Common To All Metal Poles".

### **B. Reused Poles**

Do not remove the original identification tag(s) from the pole shaft and/or mast arm sections. Add a new identification tag based on the new location for any reused poles and/or mast arms.

**11.9. REUSED POLE SHAFTS AND/OR MAST ARMS**

Provide shop drawings along with new foundation designs for review and approval prior to furnishing and/or installing any reused metal poles and/or mast arms. Use the same requirements as specified for new materials as stated above in these Special Provisions.

For reused pole shaft and mast arm combinations, it is preferable to use the original shafts and arms that were used together at the time of original installation.

**11.10. MEASUREMENT AND PAYMENT**

Actual number of metal strain signal poles (without regard to height or load capacity) furnished, installed and accepted.

Actual number of metal poles with single mast arms furnished, installed, and accepted.

Actual number of metal poles with dual mast arms furnished, installed, and accepted.

Actual number of reused metal strain signal poles (without regard to height or load capacity) furnished, installed and accepted.

Actual number of reused metal strain signal poles (without regard to height or load capacity) installed and accepted.

Actual number of reused metal poles with single mast arms furnished, installed, and accepted.

Actual number of reused metal poles with single mast arms installed and accepted.

Actual number of reused metal poles with dual mast arms furnished, installed, and accepted.

Actual number of reused metal poles with dual mast arms installed and accepted.

Actual number of soil tests with SPT borings drilled furnished and accepted.

Actual volume of concrete poured in cubic yards of drilled pier foundation furnished, installed and accepted.

Actual number of foundations with wing walls furnished, installed and accepted, excluding foundation length. Refer to method of measurement above for drilled pier foundation.

Actual number of designs for metal strain poles furnished and accepted.

Actual number of designs for mast arms with metal poles furnished and accepted.

Actual number of metal signal pole foundations removed and disposed.

Actual number of metal signal poles removed and disposed.

No measurement will be made for foundation designs prepared with metal pole designs, as these will be considered incidental to designing signal support structures.

Actual number of Single mast arm assemblies with protective coatings furnished, installed, and accepted.

Actual number of Dual mast arm assemblies with protective coatings furnished, installed, and accepted.

Actual number of Strain Pole assemblies with protective coatings furnished, installed, and accepted.

**TIP Number**

**County Name**

Signals & Intelligent Transportation Systems

Actual number of pedestrian signal pedestals and bases with protective coatings furnished, installed, and accepted.

**Payment will be made under:**

|   |            |
|---|------------|
| Metal Strain Signal Pole.....                                     | Each       |
| Metal Pole with Single Mast Arm .....                             | Each       |
| Metal Pole with Dual Mast Arm.....                                | Each       |
| Furnish and Install Reused Metal Strain Signal Pole.....          | Each       |
| Install Reused Metal Strain Signal Pole .....                     | Each       |
| Furnish and Install Reused Metal Pole with Single Mast Arm .....  | Each       |
| Install Reused Metal Pole with Single Mast Arm.....               | Each       |
| Furnish and Install Reused Metal Pole with Dual Mast Arm.....     | Each       |
| Install Reused Metal Pole with Dual Mast Arm.....                 | Each       |
| Soil Test.....  | Each       |
| Drilled Pier Foundation.....                                      | Cubic Yard |
| Foundation with Wing Walls (_____).....                           | Each       |
| Metal Strain Pole Design.....                                     | Each       |
| Mast Arm with Metal Pole Design .....                             | Each       |
| Metal Pole Foundation Removal .....                               | Each       |
| Metal Pole Removal.....   | Each       |
| Single mast arm pole assembly with Protective Coating .....       | Each       |
| Dual mast arm pole assembly with Protective Coating .....         | Each       |
| Pedestrian Signal Pedestal assembly with Protective Coating ..... | Each       |
| Strain Pole assembly with Protective Coating.....                 | Each       |

**12. CONTROLLERS WITH CABINETS**

**12.1. MATERIALS – TYPE 170E CONTROLLERS**

Conform to the CALTRANS *Traffic Signal Control Equipment Specifications* and addendum 8, *Specifications for Model 170E Enhanced Controller Unit and Associated Model 412C and Model 172 Modules* except as required herein.

Provide model 412C Program Modules as defined in CALTRANS Addendum 8 except as specified otherwise herein. Provide program module delivery with Memory Select #4 Configuration except that all RAM must be DALLAS Non-volatile RAM or an approved equal. Ensure that the removal of the program module from the controller will place the intersection into flash.

Provide diagnostic software or removable diagnostic PROM modules that will test and diagnose the following:

- systems of the controller, including the internal memory, Program Module, Real Time Clock, I/O circuitry, display, and keyboard;
- systems of the cabinet, including the output file, input file, police panel, flashing operation, and cabinet switches; and
- systems of the conflict monitor by checking all possible conflicts in a logical sequence and resetting the conflict monitor each time, and by testing red failure function and red detect cable disconnects.

Ensure that the automatic reset function can be enabled by inserting a diagnostic plug in the jack labeled “Conflict Monitor Test” in the “TEST” position.

In addition to CALTRANS system communications capability between a central computer and master controller and master to local controller communications, provide communications capability with the intersection conflict monitor via an RS-232C/D port on the monitor. Ensure controller receives data from the conflict monitor through a controller Asynchronous Communications Interface Adapter (ACIA) determined by the controller software manufacturer. Ensure that with the appropriate software, the controller is capable of communicating directly through a laptop nine pin serial port to the same monitor RS-232C/D to retrieve all event log information.

Furnish a communications connecting cable with the following pin connections.

| <b>170</b> |            | <b>Conflict Monitor DB-9</b> |
|------------|------------|------------------------------|
| RX pin L   | Connect to | TX pin 2                     |
| TX pin K   | Connect to | RX pin 3                     |
| +5 pin D   | Connect to | DTR pin 4                    |
| GND pin N  | Connect to | GND pin 5                    |

Provide a male DB-9 connector on the cable for connection to the monitor.

Provide socket mounting for through-hole mount devices with 14 or more pins. Ensure that all sockets are AUGAT-500 series machined sockets, or equal.

Provide a moisture resistant coating on all circuit boards. Mount circuit boards vertically.

**12.2. MATERIALS – TYPE 2070L CONTROLLERS**

Conform to CALTRANS *Transportation Electrical Equipment Specifications (TEES)* (dated August 16, 2002, plus Errata 1 dated October 27, 2003 and Errata 2 dated June 08, 2004) except as required herein.

Furnish Model 2070L controllers. Ensure that removal of the CPU module from the controller will place the intersection into flash.

The Department will provide software at the beginning of the burning-in period. Contractor shall give 5 working days notice before needing software. Program software provided by the Department.

Provide model 2070L controllers with the latest version of OS9 operating software and device drivers, composed of the unit chassis and at a minimum the following modules and assemblies:

- MODEL 2070 1B, CPU Module, Single Board
- MODEL 2070-2A, Field I/O Module (FI/O)
  - Note: Configure the Field I/O Module to disable both the External WDT Shunt/Toggle Switch and SP3 (SP3 active indicator is “off”)
- MODEL 2070-3B, Front Panel Module (FP), Display B (8x40)
- MODEL 2070-4A, Power Supply Module, 10 AMP
- MODEL 2070-7A, Async Serial Com Module (9-pin RS-232)

Furnish one additional MODEL 2070-7A, Async Serial Com Module (9-pin RS-232) for all master controller locations.

For each master location and central control center, furnish a U.S. Robotics V.92 or approved equivalent auto-dial/auto-answer external modem to accomplish the interface to the Department-furnished microcomputers. Include all necessary hardware to ensure telecommunications.

**12.3. MATERIALS – NEMA TS-1 CONTROLLERS**

Furnish NEMA TS-1 controller (*insert model number here*), or approved equivalent. Include a NEMA standard overlap card.

Ensure that all components are arranged for easy access during servicing. When modular in construction, provide guides and positive connection devices to insure proper pin alignment and connection.

Provide a moisture resistant coating on all circuit boards.

**12.4. MATERIALS – NEMA TS-2 TYPE 2 CONTROLLERS**

Furnish NEMA TS-2, Type 2 (*insert model number here*), or approved equivalent. Include a NEMA standard overlap card.

Ensure that all components are arranged for easy access during servicing. When modular in construction, provide guides and positive connection devices to insure proper pin alignment and connection.

Provide a moisture resistant coating on all circuit boards.

**12.5. MATERIALS – GENERAL CABINETS**

Provide a moisture resistant coating on all circuit boards.

Provide one 20 mm diameter radial lead UL-recognized metal oxide varistor (MOV) between each load switch field terminal and equipment ground. Electrical performance is outlined below.

| <b>PROPERTIES OF MOV SURGE PROTECTOR</b>     |                          |
|--|--------------------------|
| Maximum Continuous Applied Voltage at 185° F | 150 VAC (RMS)<br>200 VDC |
| Maximum Peak 8x20µs Current at 185° F        | 6500 A                   |
| Maximum Energy Rating at 185° F              | 80 J                     |
| Voltage Range 1 mA DC Test at 77° F          | 212-268 V                |
| Max. Clamping Voltage 8x20µs, 100A at 77° F  | 395 V                    |
| Typical Capacitance (1 MHz) at 77° F         | 1600 pF                  |

Provide a power line surge protector that is a two-stage device that will allow connection of the radio frequency interference filter between the stages of the device. Ensure that a maximum continuous current is at least 10A at 120V. Ensure that the device can withstand a minimum of 20 peak surge current occurrences at 20,000A for an 8x20 microsecond waveform. Provide a maximum clamp voltage of 395V at 20,000A with a nominal series inductance of 200µh. Ensure that the voltage does not exceed 395V. Provide devices that comply with the following:

| Frequency (Hz) | Minimum Insertion Loss (dB) |
|----------------|-----------------------------|
| 60             | 0                           |
| 10,000         | 30                          |
| 50,000         | 55                          |
| 100,000        | 50                          |
| 500,000        | 50                          |
| 2,000,000      | 60                          |
| 5,000,000      | 40                          |
| 10,000,000     | 20                          |
| 20,000,000     | 25                          |

**12.6. MATERIALS – TYPE 170E CABINETS**

**A. Type 170 E Cabinets General:**

Conform to the city of Los Angeles’ Specification No. 54-053-08, *Traffic Signal Cabinet Assembly Specification* (dated July 2008), except as required herein.

Furnish model 336S pole mounted cabinets configured for 8 vehicle phases, 4 pedestrian phases, and 6 overlaps. When overlaps are required, provide auxiliary output files for the overlaps. Do not reassign load switches to accommodate overlaps unless shown on electrical details. Provide 336S pole mounted cabinets that are 46” high with 40” high internal rack assemblies.

Furnish model 332 base mounted cabinets configured for 8 vehicle phases, 4 pedestrian phases, and 6 overlaps. When overlaps are required, provide auxiliary output files for the overlaps. Do not reassign load switches to accommodate overlaps unless shown on electrical details.

Provide model 200 load switches, model 222 loop detector sensors, model 252 AC isolators, and model 242 DC isolators according to the electrical details. As a minimum, provide one (1) model 2018 conflict monitor, one (1) model 206L power supply unit, two (2) model 204 flashers, one (1) DC isolator (located in slot I14), and four (4) model 430 flash transfer relays (provide seven (7) model 430 flash transfer relays if auxiliary output file is installed) with each cabinet.



**B. Type 170 E Cabinet Electrical Requirements:**

Provide a cabinet assembly designed to ensure that upon leaving any cabinet switch or conflict monitor initiated flashing operation, the controller starts up in the programmed start up phases and start up interval.

Furnish two sets of non-fading cabinet wiring diagrams and schematics in a paper envelope or container and placed in the cabinet drawer.

All AC+ power is subject to radio frequency signal suppression.

Provide surge suppression in the cabinet for each type of cabinet device. Provide surge protection for the full capacity of the cabinet input file. Provide surge suppression devices that operate properly over a temperature range of -40° F to +185° F. Ensure the surge suppression devices provide both common and differential modes of protection.

Provide a pluggable power line surge protector that is installed on the back of the PDA (power distribution assembly) chassis to filter and absorb power line noise and switching transients. Ensure the device incorporates LEDs for failure indication and provides a dry relay contact closure for the purpose of remote sensing. Ensure the device meets the following specifications:

|  |                      |
|--|----------------------|
| Peak Surge Current (Single pulse, 8x20µs)..... | 20,000A              |
| Occurrences (8x20µs waveform).....             | 10 minimum @ 20,000A |
| Maximum Clamp Voltage.....                     | 395VAC               |
| Operating Current.....                         | 15 amps              |
| Response Time.....                             | < 5 nanoseconds      |

Provide a loop surge suppressor for each set of loop terminals in the cabinet. Ensure the device meets the following specifications:

|                                      |                 |
|--------------------------------------|-----------------|
| Peak Surge Current (6 times, 8x20µs) |                 |
| (Differential Mode).....             | 400A            |
| (Common Mode).....                   | 1,000A          |
| Occurrences (8x20µs waveform).....   | 500 min @ 200A  |
| Maximum Clamp Voltage                |                 |
| (Differential Mode @400A).....       | 35V             |
| (Common Mode @1,000A).....           | 35V             |
| Response Time.....                   | < 5 nanoseconds |
| Maximum Capacitance.....             | 35 pF           |

**TIP Number**

**County Name**

**Signals & Intelligent Transportation Systems**

Provide a data communications surge suppressor for each communications line entering or leaving the cabinet. Ensure the device meets the following specifications:

- Peak Surge Current (Single pulse, 8x20µs).....10,000A
- Occurrences (8x20µs waveform).....100 min @ 2,000A
- Maximum Clamp Voltage.....Rated for equipment protected
- Response Time.....< 1 nanosecond
- Maximum Capacitance.....1,500 pF
- Maximum Series Resistance.....15Ω

Provide a DC signal surge suppressor for each DC input channel in the cabinet. Ensure the device meets the following specifications:

- Peak Surge Current (Single pulse, 8x20µs).....10,000A
- Occurrences (8x20µs waveform).....100 @ 2,000A
- Maximum Clamp Voltage.....30V
- Response Time.....< 1 nanosecond

Provide a 120 VAC signal surge suppressor for each AC+ interconnect signal input. Ensure the device meets the following specifications:

- Peak Surge Current (Single pulse, 8x20µs).....20,000A
- Maximum Clamp Voltage.....350VAC
- Response Time.....< 200 nanoseconds
- Discharge Voltage.....<200 Volts @ 1,000A
- Insulation Resistance.....≥100 MΩ

Provide conductors for surge protection wiring that are of sufficient size (ampacity) to withstand maximum overcurrents which could occur before protective device thresholds are attained and current flow is interrupted.

If additional surge protected power outlets are needed to accommodate fiber transceivers, modems, etc., install a UL listed, industrial, heavy-duty type power outlet strip with a minimum rating of 15 A / 125 VAC, 60 Hz. Provide a strip that has a minimum of 3 grounded outlets. Ensure the power outlet strip plugs into one of the controller unit receptacles located on the rear of the PDA. Ensure power outlet strip is mounted securely; provide strain relief if necessary.

Provide a door switch in the front and a door switch in the rear of the cabinet that will provide the controller unit with a Door Ajar alarm when either the front or the rear door is open. Ensure the door switches apply DC ground to the Input File when either the front door or the rear door is open.

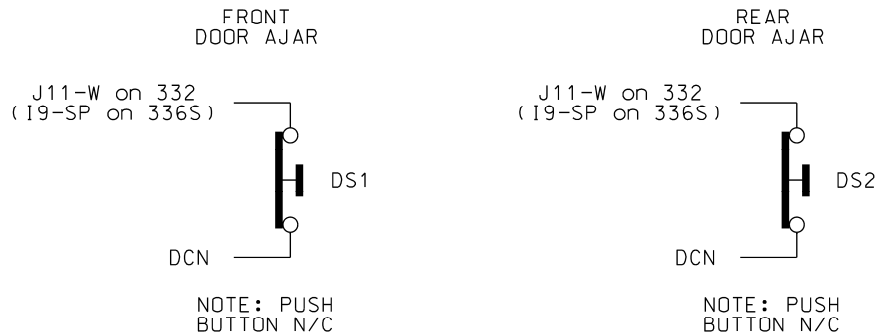

Furnish a fluorescent fixture in the rear across the top of the cabinet and another fluorescent fixture in the front across the top of the cabinet at a minimum. Ensure that the fixtures provide sufficient light to illuminate all terminals, labels, switches, and devices in the cabinet. Conveniently locate the fixtures so as not to interfere with a technician's ability to perform work on any devices or terminals in the cabinet. Provide a protective diffuser to cover exposed bulbs. Install 16 watt T-4 lamps in the fluorescent fixtures. Provide a door switch to provide power to each fixture when the respective door is open. Wire the fluorescent fixtures to the 15 amp ECB (equipment circuit breaker).

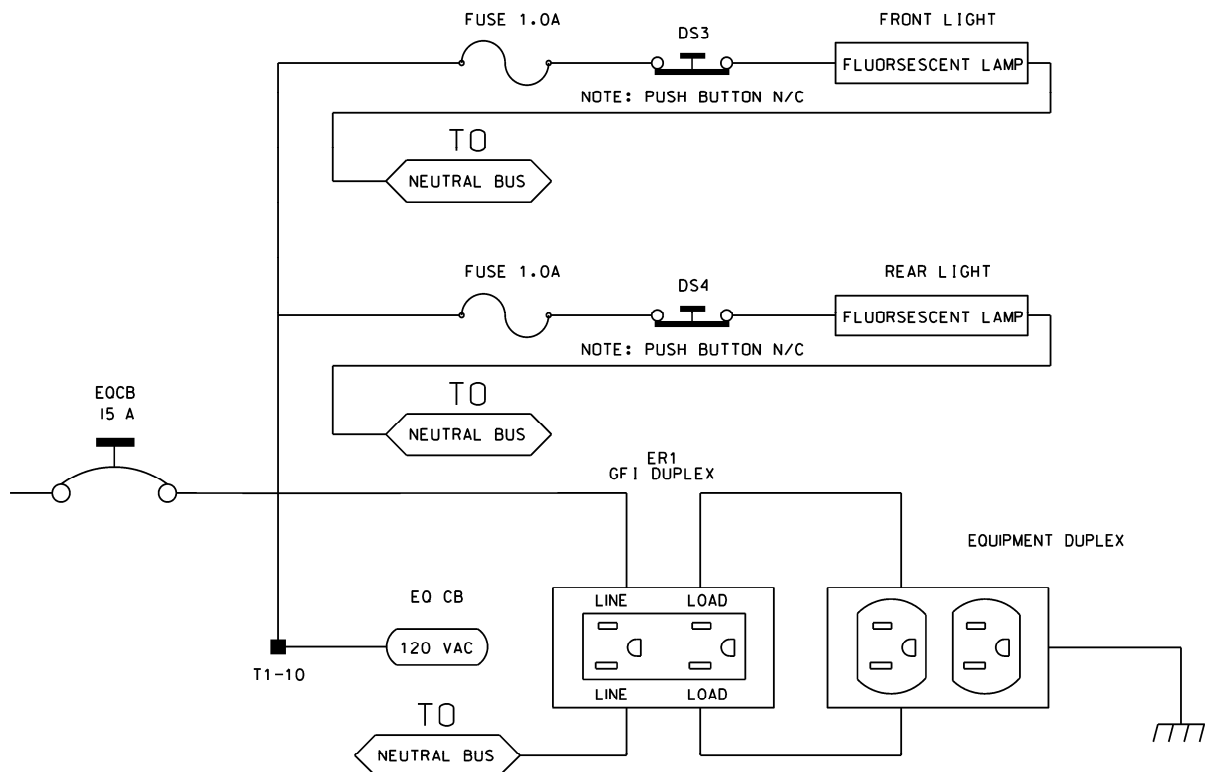

**TIP Number****County Name****Signals & Intelligent Transportation Systems**

Furnish a police panel with a police panel door. For model 336S cabinets, mount the police panel on the rear door. Ensure that the police panel door permits access to the police panel when the main door is closed. Ensure that no rainwater can enter the cabinet even with the police panel door open. Provide a police panel door hinged on the right side as viewed from the front. Provide a police panel door lock that is keyed to a standard police/fire call box key. In addition to the requirements of LA Specification No. 54-053-08, provide the police panel with a toggle switch connected to switch the intersection operation between normal stop-and-go operation (AUTO) and manual operation (MANUAL). Ensure that manual control can be implemented using inputs and software such that the controller provides full programmed clearance times for the yellow clearance and red clearance for each phase while under manual control.

Provide a 1/4-inch locking phone jack in the police panel for a hand control to manually control the intersection. Provide sufficient room in the police panel for storage of a hand control and cord.

Ensure the 336S cabinet Input File is wired as follows:

| <b>336S Cabinet</b>                |     |     |     |     |     |     |     |     |     |     |     |     |     |     |
|------------------------------------|-----|-----|-----|-----|-----|-----|-----|-----|-----|-----|-----|-----|-----|-----|
| <b>Port-Bit/C-1 Pin Assignment</b> |     |     |     |     |     |     |     |     |     |     |     |     |     |     |
| Slot #                             | 1   | 2   | 3   | 4   | 5   | 6   | 7   | 8   | 9   | 10  | 11  | 12  | 13  | 14  |
| C-1 (Spares)                       | 59  | 60  | 61  | 62  | 63  | 64  | 65  | 66  | 75  | 76  | 77  | 78  | 79  | 80  |
| Port                               | 3-2 | 1-1 | 3-4 | 1-3 | 3-1 | 1-2 | 3-3 | 1-4 | 2-5 | 5-5 | 5-6 | 5-1 | 5-2 | 6-7 |
| C-1                                | 56  | 39  | 58  | 41  | 55  | 40  | 57  | 42  | 51  | 71  | 72  | 67  | 68  | 81  |
| Port                               | 2-1 | 1-5 | 2-3 | 1-7 | 2-2 | 1-6 | 2-4 | 1-8 | 2-6 | 5-7 | 5-8 | 5-3 | 5-4 | 6-8 |
| C-1                                | 47  | 43  | 49  | 45  | 48  | 44  | 50  | 46  | 52  | 73  | 74  | 69  | 70  | 82  |

For model 332 base mounted cabinets, ensure terminals J14-E and J14-K are wired together on the rear of the Input File. Connect TB9-12 (J14 Common) on the Input Panel to T1-2 (AC-) on the rear of the PDA.

Provide detector test switches mounted at the top of the cabinet rack or other convenient location which may be used to place a call on each of eight phases based on the chart below. Provide three positions for each switch: On (place call), Off (normal detector operation), and Momentary On (place momentary call and return to normal detector operation after switch is released). Ensure that the switches are located such that the technician can read the controller display and observe the intersection.

Connect detector test switches for cabinets as follows:

| 336S Cabinet           |           | 332 Cabinet            |           |
|------------------------|-----------|------------------------|-----------|
| Detector Call Switches | Terminals | Detector Call Switches | Terminals |
| Phase 1                | I1-F      | Phase 1                | I1-W      |
| Phase 2                | I2-F      | Phase 2                | I4-W      |
| Phase 3                | I3-F      | Phase 3                | I5-W      |
| Phase 4                | I4-F      | Phase 4                | I8-W      |
| Phase 5                | I5-F      | Phase 5                | J1-W      |
| Phase 6                | I6-F      | Phase 6                | J4-W      |
| Phase 7                | I7-F      | Phase 7                | J5-W      |
| Phase 8                | I8-F      | Phase 8                | J8-W      |

Provide the PCB 28/56 connector for the conflict monitor unit (CMU) with 28 independent contacts per side, dual-sided with 0.156 inch contact centers. Provide the PCB 28/56 connector contacts with solder eyelet terminations. Ensure all connections to the PCB 28/56 connector are soldered to the solder eyelet terminations.

Ensure that all cabinets have the CMU connector wired according to the 332 cabinet connector pin assignments (include all wires for auxiliary output file connection). Wire pins 13, 16, R, and U of the CMU connector to a separate 4 pin plug, P1, as shown below. Provide a second plug, P2, which will mate with P1 and is wired to the auxiliary output file as shown below. Provide an additional plug, P3, which will mate with P1 and is wired to the pedestrian yellow circuits as shown below. When no auxiliary output file is installed in the cabinet, provide wires for the green and yellow inputs for channels 11, 12, 17, and 18, the red inputs for channels 17 and 18, and the wires for the P2 plug. Terminate the two-foot wires with ring type lugs, insulated, and bundled for optional use.

| PIN | P1       |         | P2       |         | P3       |         |
|-----|----------|---------|----------|---------|----------|---------|
|     | FUNCTION | CONN TO | FUNCTION | CONN TO | FUNCTION | CONN TO |
| 1   | CH-9G    | CMU-13  | OLA-GRN  | A123    | 2P-YEL   | 114     |
| 2   | CH-9Y    | CMU-16  | OLA-YEL  | A122    | 4P-YEL   | 105     |
| 3   | CH-10G   | CMU-R   | OLB-GRN  | A126    | 6P-YEL   | 120     |
| 4   | CH-10Y   | CMU-U   | OLB-YEL  | A125    | 8P-YEL   | 111     |

Do not provide the P20 terminal assembly (red monitor board) or red interface ribbon cable as specified in LA Specification No. 54-053-08.

Provide a P20 connector that mates with and is compatible with the red interface connector mounted on the front of the conflict monitor. Ensure that the P20 connector and the red interface

connector on the conflict monitor are center polarized to ensure proper connection. Ensure that removal of the P20 connector will cause the conflict monitor to recognize a latching fault condition and place the cabinet into flashing operation.

Wire the P20 connector to the output file and auxiliary output file using 22 AWG stranded wires. Ensure the length of these wires is a minimum of 42 inches in length. Provide a durable braided sleeve around the wires to organize and protect the wires.

Wire the P20 connector to the traffic signal red displays to provide inputs to the conflict monitor as shown below. Ensure the pedestrian Don't Walk circuits are wired to channels 13 through 16 of the P20 connector. When no auxiliary output file is installed in the cabinet, provide wires for channels 9 through 12 reds. Provide a wire for special function 1. Terminate the unused wires with ring type lugs, insulated, and bundled for optional use.

| P20 Connector |                |         |     |                 |         |
|---------------|----------------|---------|-----|-----------------|---------|
| PIN           | FUNCTION       | CONN TO | PIN | FUNCTION        | CONN TO |
| 1             | Channel 15 Red | 119     | 2   | Channel 16 Red  | 110     |
| 3             | Channel 14 Red | 104     | 4   | Chassis GND     | 01-9    |
| 5             | Channel 13 Red | 113     | 6   | N/C             |         |
| 7             | Channel 12 Red | AUX 101 | 8   | Spec Function 1 |         |
| 9             | Channel 10 Red | AUX 124 | 10  | Channel 11 Red  | AUX 114 |
| 11            | Channel 9 Red  | AUX 121 | 12  | Channel 8 Red   | 107     |
| 13            | Channel 7 Red  | 122     | 14  | Channel 6 Red   | 134     |
| 15            | Channel 5 Red  | 131     | 16  | Channel 4 Red   | 101     |
| 17            | Channel 3 Red  | 116     | 18  | Channel 2 Red   | 128     |
| 19            | Channel 1 Red  | 125     | 20  | Red Enable      | 01-14   |

Ensure the controller unit outputs to the auxiliary output file are pre-wired to the C5 connector. When no auxiliary output file is installed in the cabinet, connect the C5 connector to a storage socket located on the Input Panel or on the rear of the PDA.

Do not wire pin 12 of the load switch sockets.

In addition to the requirements of LA Specification No. 54-053-08, ensure relay K1 on the Power Distribution Assembly (PDA) is a four pole relay and K2 on the PDA is a two pole relay.

Provide a two pole, ganged circuit breaker for the flash bus circuit. Ensure the flash bus circuit breaker is an inverse time circuit breaker rated for 10 amps at 120 VAC with a minimum of 10,000 RMS symmetrical amperes short circuit current rating. Do not provide the auxiliary switch feature on the flash bus circuit breaker. Ensure the ganged flash bus circuit breaker is certified by the circuit breaker manufacturer to provide gang tripping operation.

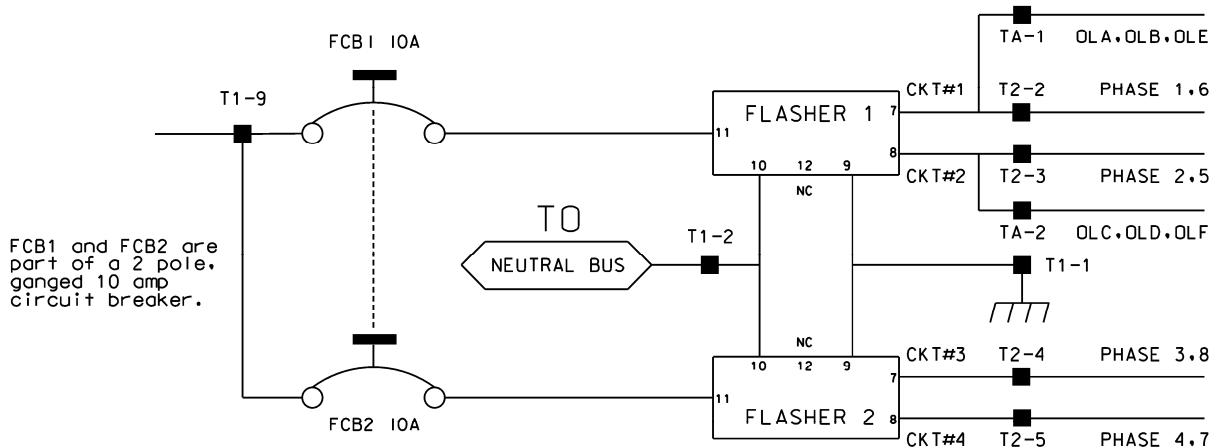

Ensure auxiliary output files are wired as follows:

| <b>AUXILIARY OUTPUT FILE</b>         |   |
|--------------------------------------|---|
| <b>TERMINAL BLOCK TA ASSIGNMENTS</b> |   |
| <b>POSITION</b>                      | <b>FUNCTION</b>                                       |
| 1                                    | Flasher Unit #1, Circuit 1/FTR1 (OLA, OLB)/FTR3 (OLE) |
| 2                                    | Flasher Unit #1, Circuit 2/FTR2 (OLC, OLD)/FTR3 (OLF) |
| 3                                    | Flash Transfer Relay Coils                            |
| 4                                    | AC -  |
| 5                                    | Power Circuit 5                                       |
| 6                                    | Power Circuit 5                                       |
| 7                                    | Equipment Ground Bus                                  |
| 8                                    | NC  |

Provide four spare load resistors mounted in each cabinet. Ensure each load resistor is rated as shown in the table below. Wire one side of each load resistor to AC-. Connect the other side of each resistor to a separate terminal on a four (4) position terminal block. Mount the load resistors and terminal block either inside the back of Output File No. 1 or on the upper area of the Service Panel.

| <b>ACCEPTABLE LOAD RESISTOR VALUES</b> |                |
|--|----------------|
| <b>VALUE (ohms)</b>                    | <b>WATTAGE</b> |
| 1.5K – 1.9 K                           | 25W (min)      |
| 2.0K – 3.0K                            | 10W (min)      |

Provide Model 200 load switches, Model 204 flashers, Model 242 DC isolators, Model 252 AC isolators, and Model 206L power supply units that conform to CALTRANS’ *“Transportation Electrical Equipment Specifications”* dated March 12, 2009 with Erratum 1.

**C. Type 170 E Cabinet Physical Requirements:**

Do not mold, cast, or scribe the name “City of Los Angeles” on the outside of the cabinet door as specified in LA Specification No. 54-053-08. Do not provide a Communications Terminal Panel as specified in LA Specification No. 54-053-08. Do not provide terminal block TBB on the Service Panel. Do not provide Cabinet Verification Test Program software or associated test jigs as specified in LA Specification No. 54-053-08.

Furnish unpainted, natural, aluminum cabinet shells. Ensure that all non-aluminum hardware on the cabinet is stainless steel or a Department approved non-corrosive alternate.

Ensure the lifting eyes, gasket channels, police panel, and all supports welded to the enclosure and doors are fabricated from 0.125 inch minimum thickness aluminum sheet and meet the same standards as the cabinet and doors.

Provide front and rear doors with latching handles that allow padlocking in the closed position. Furnish 0.75 inch minimum diameter stainless steel handles with a minimum 0.5 inch shank. Place the padlocking attachment at 4.0 inches from the handle shank center to clear the lock and key. Provide an additional 4.0 inches minimum gripping length.

Provide Corbin #2 locks on the front and rear doors. Provide one (1) Corbin #2 and one (1) police master key with each cabinet. Ensure main door locks allow removal of keys in the locked position only.

Provide a surge protection panel with 16 loop surge protection devices and designed to allow sufficient free space for wire connection/disconnection and surge protection device replacement. For model 332 cabinets, provide an additional 20 loop surge protection devices. Provide an additional two AC+ interconnect surge devices to protect one slot and eight DC surge protection devices to protect four slots. Provide no protection devices on slot I14.

For pole mounted cabinets, mount surge protection devices for the AC+ interconnect inputs, inductive loop detector inputs, and low voltage DC inputs on a swing down panel assembly fabricated from sturdy aluminum. Attach the swing down panel to the bottom rear cabinet rack assembly using thumb screws. Ensure the swing down panel allows for easy removal of the input file without removing the surge protection panel assembly or its parts. Have the surge protection devices mounted horizontally on the panel and soldered to the feed through terminals of four 14 position terminal blocks with #8 screws mounted on the other side. Ensure the top row of terminals is connected to the upper slots and the bottom row of terminals is connected to the bottom slots. Provide a 15 position copper equipment ground bus attached to the field terminal side (outside) of



the swing down panel for termination of loop lead-in shield grounds. Ensure that a Number 4 AWG green wire connects the surge protection panel assembly ground bus to the main cabinet equipment ground.

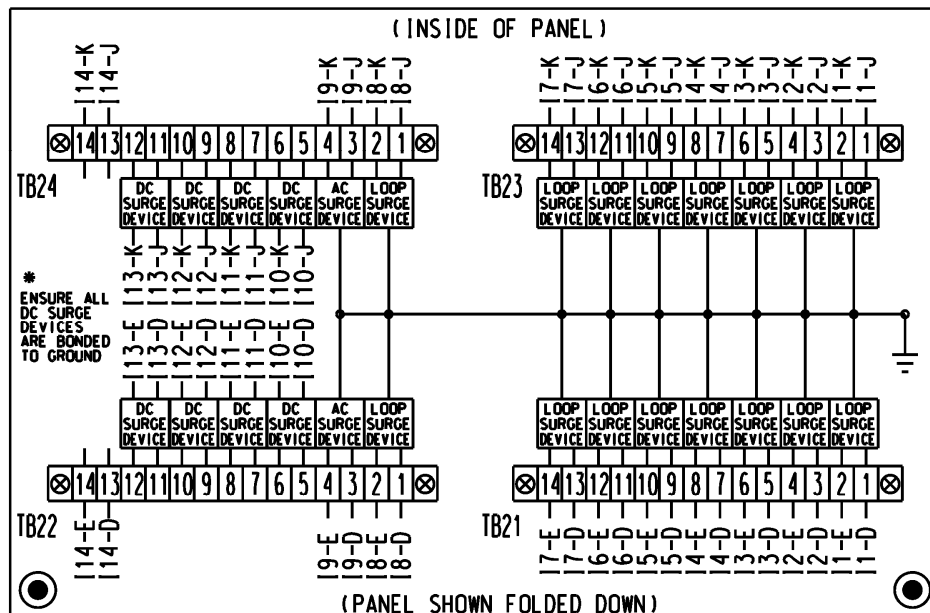
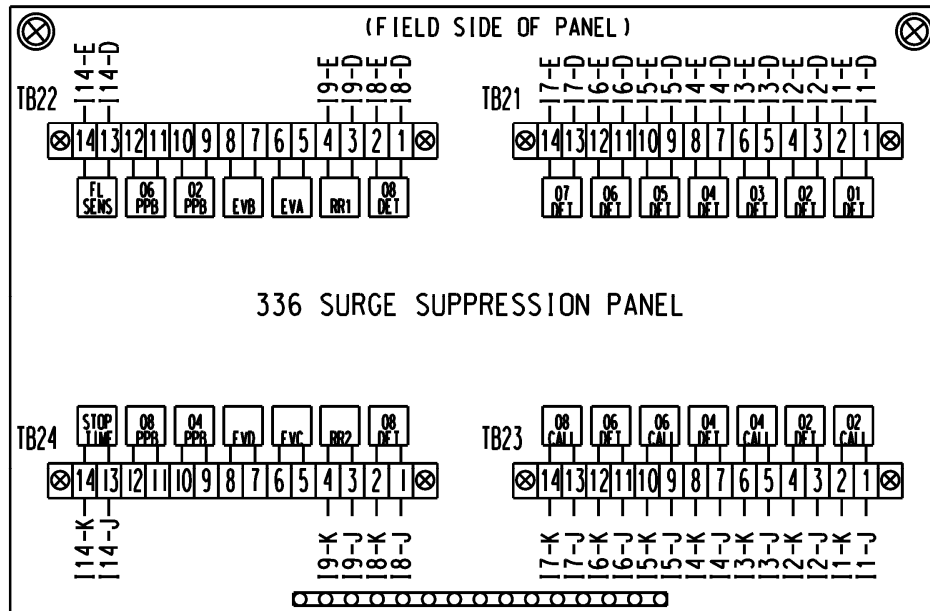

For base mounted cabinets, mount surge protection panels on the left side of the cabinet as viewed from the rear. Attach each panel to the cabinet rack assembly using bolts and make it easily removable. Mount the surge protection devices in vertical rows on each panel and connect the

devices to one side of 12 position, double row terminal blocks with #8 screws. For each surge protection panel, terminate all grounds from the surge protection devices on a copper equipment ground bus attached to the surge protection panel. Wire the terminals to the rear of a standard input file using spade lugs for input file protection.

Provide permanent labels that indicate the slot and the pins connected to each terminal that may be viewed from the rear cabinet door. Label and orient terminals so that each pair of inputs is next to each other. Indicate on the labeling the input file (I or J), the slot number (1-14) and the terminal pins of the input slots (either D & E for upper or J & K for lower).

Provide a minimum 14 x 16 inch pull out, hinged top shelf located immediately below controller mounting section of the cabinet. Ensure the shelf is designed to fully expose the table surface outside the controller at a height approximately even with the bottom of the controller. Ensure the shelf has a storage bin interior which is a minimum of 1 inch deep and approximately the same dimensions as the shelf. Provide an access to the storage area by lifting the hinged top of the shelf. Fabricate the shelf and slide from aluminum or stainless steel and ensure the assembly can support the 2070L controller plus 15 pounds of additional weight. Ensure shelf has a locking mechanism to secure it in the fully extended position and does not inhibit the removal of the 2070L controller or removal of cards inside the controller when fully extended. Provide a locking mechanism that is easily released when the shelf is to be returned to its non-use position directly under the controller.

#### **D. Model 2018 Enhanced Conflict Monitor:**

Furnish Model 2018 Enhanced Conflict Monitors that provide monitoring of 18 channels. Ensure each channel consists of a green, yellow, and red field signal input. Ensure that the conflict monitor meets or exceeds CALTRANS' Transportation Electrical Equipment Specifications dated March 12, 2009 with Erratum 1 (hereafter referred to as CALTRANS' 2009 TEES) for a model 210 monitor unit and other requirements stated in this specification.

Ensure the conflict monitor is provided with an 18 channel conflict programming card. Pin EE and Pin T of the conflict programming card shall be connected together. Pin 16 of the conflict programming card shall be floating. Ensure that the absence of the conflict programming card will cause the conflict monitor to trigger (enter into fault mode), and remain in the triggered state until the programming card is properly inserted and the conflict monitor is reset.

Provide a conflict monitor that incorporates LED indicators into the front panel to dynamically display the status of the monitor under normal conditions and to provide a comprehensive review of field inputs with monitor status under fault conditions. Ensure that the monitor indicates the channels that were active during a conflict condition and the channels that experienced a failure for all other per channel fault conditions detected. Ensure that these indications and the status of each channel are retained until the Conflict Monitor is reset. Furnish LED indicators for the following:

- AC Power (Green LED indicator)
- VDC Failed (Red LED indicator)
- WDT Error (Red LED indicator)
- Conflict (Red LED indicator)
- Red Fail (Red LED indicator)
- Dual Indication (Red LED indicator)

**TIP Number****County Name**

## Signals &amp; Intelligent Transportation Systems

- Yellow/Clearance Failure (Red LED indicator)
- PCA/PC Ajar (Red LED indicator)
- Monitor Fail/Diagnostic Failure (Red LED indicator)
- 54 Channel Status Indicators (1 Red, 1 Yellow, and 1 Green LED indicator for each of the 18 channels)

Provide a switch to set the Red Fail fault timing. Ensure that when the switch is in the ON position the Red Fail fault timing value is set to 1350 +/- 150ms (2018 mode). Ensure that when the switch is in the OFF position the Red Fail fault timing value is set to 850 +/- 150ms (210 mode).

Provide a switch to set the Watchdog fault timing. Ensure that when the switch is in the ON position the Watchdog fault timing value is set to 1.0 +/- 0.1s (2018 mode). Ensure that when the switch is in the OFF position the Watchdog fault timing value is set to 1.5 +/- 0.1s (210 mode).

Provide a jumper or switch to set the AC line brown-out levels. Ensure that when the jumper is present or the switch is in the ON position the AC line dropout voltage threshold is 98 +/- 2 Vrms, the AC line restore voltage threshold is 103 +/- 2 Vrms, and the AC line brown-out timing value is set to 400 +/- 50ms (2018 mode). Ensure that when the jumper is not present or the switch is in the OFF position the AC line dropout voltage threshold is 92 +/- 2 Vrms, the AC line restore voltage threshold is 98 +/- 2 Vrms, and the AC line brown-out timing value is set to 80 +/- 17ms (210 mode).

Provide a jumper or switch that will enable and disable the Watchdog Latch function. Ensure that when the jumper is not present or the switch is in the OFF position the Watchdog Latch function is disabled. In this mode of operation, a Watchdog fault will be reset following a power loss, brownout, or power interruption. Ensure that when the jumper is present or the switch is in the ON position the Watchdog Latch function is enabled. In this mode of operation, a Watchdog fault will be retained until a Reset command is issued.

Provide a jumper that will reverse the active polarity for pin #EE (output relay common). Ensure that when the jumper is not present pin #EE (output relay common) will be considered 'Active' at a voltage greater than 70 Vrms and 'Not Active' at a voltage less than 50 Vrms (Caltrans mode). Ensure that when the jumper is present pin #EE (output relay common) will be considered 'Active' at a voltage less than 50 Vrms and 'Not Active' at a voltage greater than 70 Vrms (Failsafe mode).

In addition to the connectors required by CALTRANS' 2009 TEES, provide the conflict monitor with a red interface connector mounted on the front of the monitor. Ensure the connector is a 20 pin, right angle, center polarized, male connector with latching clip locks and polarizing keys. Ensure the right angle solder tails are designed for a 0.062" thick printed circuit board. Keying of the connector shall be between pins 3 and 5, and between 17 and 19. Ensure the connector has two rows of pins with the odd numbered pins on one row and the even pins on the other row. Ensure the connector pin row spacing is 0.10" and pitch is 0.10". Ensure the mating length of the connector pins is 0.24". Ensure the pins are finished with gold plating 30μ" thick.

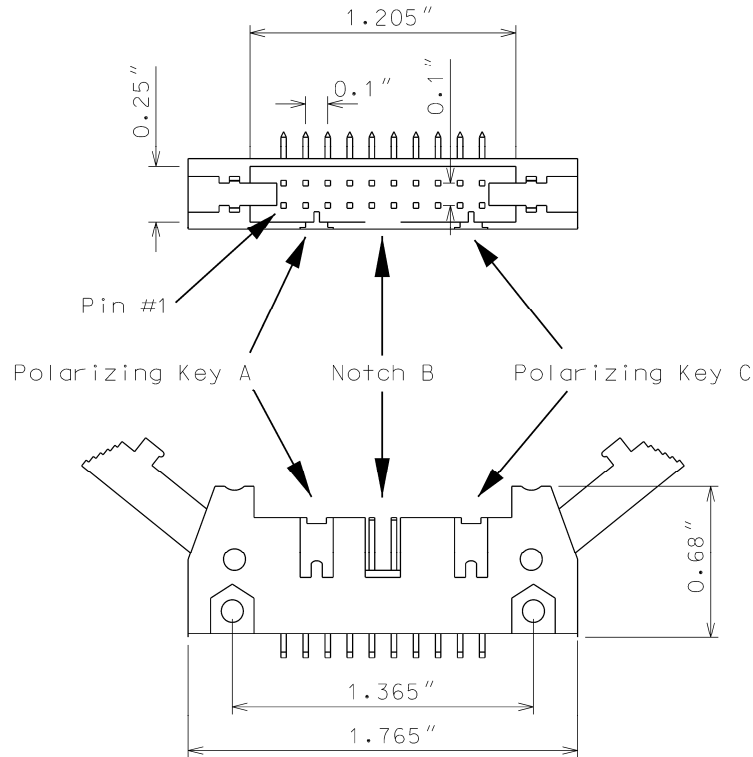

Ensure the red interface connector pins on the monitor have the following functions:

| <b>Pin #</b> | <b>Function</b> | <b>Pin #</b> | <b>Function</b>    |
|--------------|-----------------|--------------|--------------------|
| 1            | Channel 15 Red  | 2            | Channel 16 Red     |
| 3            | Channel 14 Red  | 4            | Chassis Ground     |
| 5            | Channel 13 Red  | 6            | Special Function 2 |
| 7            | Channel 12 Red  | 8            | Special Function 1 |
| 9            | Channel 10 Red  | 10           | Channel 11 Red     |
| 11           | Channel 9 Red   | 12           | Channel 8 Red      |
| 13           | Channel 7 Red   | 14           | Channel 6 Red      |
| 15           | Channel 5 Red   | 16           | Channel 4 Red      |
| 17           | Channel 3 Red   | 18           | Channel 2 Red      |
| 19           | Channel 1 Red   | 20           | Red Enable         |

Ensure that removal of the P20 cable connector will cause the conflict monitor to recognize a latching fault condition and place the cabinet into flashing operation.

Provide Special Function 1 and Special Function 2 inputs to the unit which shall disable only Red Fail Monitoring when either input is sensed active. A Special Function input shall be sensed active when the input voltage exceeds 70 Vrms with a minimum duration of 550 ms. A Special Function input shall be sensed not active when the input voltage is less than 50 Vrms or the duration is less than 250 ms. A Special Function input is undefined by these specifications and may or may not be sensed active when the input voltage is between 50 Vrms and 70 Vrms or the duration is between 250 ms and 550 ms.

Ensure the conflict monitor recognizes field signal inputs for each channel that meet the following requirements:

- consider a Red input greater than 70 Vrms and with a duration of at least 500 ms as an “on” condition;
- consider a Red input less than 50 Vrms or with a duration of less than 200 ms as an “off” condition (no valid signal);
- consider a Red input between 50 Vrms and 70 Vrms or with a duration between 200 ms and 500 ms to be undefined by these specifications;
- consider a Green or Yellow input greater than 25 Vrms and with a duration of at least 500 ms as an “on” condition;
- consider a Green or Yellow input less than 15 Vrms or with a duration of less than 200 ms as an “off” condition; and
- consider a Green or Yellow input between 15 Vrms and 25 Vrms or with a duration between 200 ms and 500 ms to be undefined by these specifications.

Provide a conflict monitor that recognizes the faults specified by CALTRANS’ 2009 TEES and the following additional faults. Ensure the conflict monitor will trigger upon detection of a fault and will remain in the triggered (in fault mode) state until the unit is reset at the front panel or through the external remote reset input for the following failures:

1. **Red Monitoring or Absence of Any Indication (Red Failure):** A condition in which no “on” voltage signal is detected on any of the green, yellow, or red inputs to a given monitor channel. If a signal is not detected on at least one input (R, Y, or G) of a conflict monitor channel for a period greater than 1000 ms when used with a 170 controller and 1500 ms when used with a 2070L controller, ensure monitor will trigger and put the intersection into flash. If the absence of any indication condition lasts less than 750 ms when used with a 170 controller and 1200 ms when used with a 2070L controller, ensure conflict monitor will not trigger. Red fail monitoring shall be enabled on a per channel basis by the use of switches located on the conflict monitor. Have red monitoring occur when all of the following input conditions are in effect:
  - a) Red Enable input to monitor is active (Red Enable voltages are “on” at greater than 70 Vrms, off at less than 50 Vrms, undefined between 50 and 70 Vrms), and
  - b) Neither Special Function 1 nor Special Function 2 inputs are active.
  - c) Pin #EE (output relay common) is not active
2. **Short/Missing Yellow Indication Fault (Clearance Error):** Yellow indication following a green is missing or shorter than 2.7 seconds (with  $\pm 0.1$ -second accuracy). If a channel fails

to detect an “on” signal at the Yellow input for a minimum of 2.7 seconds ( $\pm 0.1$  second) following the detection of an “on” signal at a Green input for that channel, ensure that the monitor triggers and generates a clearance/short yellow error fault indication. Short/missing yellow (clearance) monitoring shall be enabled on a per channel basis by the use of switches located on the conflict monitor. This fault shall not occur when the channel is programmed for Yellow Inhibit, when the Red Enable signal is inactive or pin #EE (output relay common) is active.

3. **Dual Indications on the Same Channel:** In this condition, more than one indication (R,Y,G) is detected as “on” at the same time on the same channel. If dual indications are detected for a period greater than 500 ms, ensure that the conflict monitor triggers and displays the proper failure indication (Dual Ind fault). If this condition is detected for less than 200 ms, ensure that the monitor does not trigger. G-Y-R dual indication monitoring shall be enabled on a per channel basis by the use of switches located on the conflict monitor. G-Y dual indication monitoring shall be enabled for all channels by use of a switch located on the conflict monitor. This fault shall not occur when the Red Enable signal is inactive or pin #EE (output relay common) is active.
4. **Configuration Settings Change:** The configuration settings are comprised of (as a minimum) the permissive diode matrix, dual indication switches, yellow disable jumpers, any option switches, any option jumpers, and the Watchdog Enable switch. Ensure the conflict monitor compares the current configuration settings with the previous stored configuration settings on power-up, on reset, and periodically during operation. If any of the configuration settings are changed, ensure that the conflict monitor triggers and causes the program card indicator to flash. Ensure that configuration change faults are only reset by depressing and holding the front panel reset button for a minimum of three seconds. Ensure the external remote reset input does not reset configuration change faults.

Ensure the conflict monitor will trigger and the AC Power indicator will flash at a rate of 2 Hz  $\pm$  20% with a 50% duty cycle when the AC Line voltage falls below the “drop-out” level. Ensure the conflict monitor will resume normal operation when the AC Line voltage returns above the “restore” level. Ensure the AC Power indicator will remain illuminated when the AC voltage returns above the “restore” level. Should an AC Line power interruption occur while the monitor is in the fault mode, then upon restoration of AC Line power, the monitor will remain in the fault mode and the correct fault and channel indicators will be displayed.

Provide a flash interval of at least 6 seconds and at most 10 seconds in duration following a power-up, an AC Line interruption, or a brownout restore. Ensure the conflict monitor will suspend all fault monitoring functions, close the Output relay contacts, and flash the AC indicator at a rate of 4 Hz  $\pm$  20% with a 50% duty cycle during this interval. Ensure the termination of the flash interval after at least 6 seconds if the Watchdog input has made 5 transitions between the True and False state and the AC Line voltage is greater than the “restore” level. If the watchdog input has not made 5 transitions between the True and False state within 10  $\pm$  0.5 seconds, the monitor shall enter a WDT error fault condition.

Ensure the conflict monitor will monitor an intersection with a minimum of four approaches using the four-section Flashing Yellow Arrow (FYA) vehicle traffic signal as outlined by the NCHRP 3-54 research project for protected-permissive left turn signal displays. Ensure the conflict monitor will operate in the FYA mode and FYAc (Compact) mode as specified below to monitor each channel for the following fault conditions: Conflict, Red Fail, Dual Indication, and Clearance. Provide a switch

**TIP Number****County Name**

## Signals &amp; Intelligent Transportation Systems

to select between the FYA mode and FYAc mode. Provide a switch to select each FYA phase movement for monitoring.

**FYA mode**

|                       |                  |                   |                   |                   |
|-----------------------|------------------|-------------------|-------------------|-------------------|
| FYA Signal Head       | Phase 1          | Phase 3           | Phase 5           | Phase 7           |
| Red Arrow             | Channel 9 Red    | Channel 10 Red    | Channel 11 Red    | Channel 12 Red    |
| Yellow Arrow          | Channel 9 Yellow | Channel 10 Yellow | Channel 11 Yellow | Channel 12 Yellow |
| Flashing Yellow Arrow | Channel 9 Green  | Channel 10 Green  | Channel 11 Green  | Channel 12 Green  |
| Green Arrow           | Channel 1 Green  | Channel 3 Green   | Channel 5 Green   | Channel 7 Green   |

**FYAc mode**

|                       |                  |                  |                  |                   |
|-----------------------|------------------|------------------|------------------|-------------------|
| FYA Signal Head       | Phase 1          | Phase 3          | Phase 5          | Phase 7           |
| Red Arrow             | Channel 1 Red    | Channel 3 Red    | Channel 5 Red    | Channel 7 Red     |
| Yellow Arrow          | Channel 1 Yellow | Channel 3 Yellow | Channel 5 Yellow | Channel 7 Yellow  |
| Flashing Yellow Arrow | Channel 1 Green  | Channel 3 Green  | Channel 5 Green  | Channel 7 Green   |
| Green Arrow           | Channel 9 Green  | Channel 9 Yellow | Channel 10 Green | Channel 10 Yellow |

Ensure that the conflict monitor will log at least nine of the most recent events detected by the monitor in non-volatile EEPROM memory (or equivalent). For each event, record at a minimum the time, date, type of event, status of each field signal indication with RMS voltage, and specific channels involved with the event. Ensure the conflict monitor will log the following events: monitor reset, configuration, previous fault, and AC line. Furnish the signal sequence log that shows all channel states (Greens, Yellows, and Reds) and the Red Enable State for a minimum of 2 seconds

**TIP Number****County Name**

## Signals &amp; Intelligent Transportation Systems

prior to the current fault trigger point. Ensure the display resolution of the inputs for the signal sequence log is not greater than 50 ms.

Provide a RS-232C/D compliant port (DB-9 female connector) on the front panel of the conflict monitor in order to provide communications from the conflict monitor to the 170/2070L controller or to a Department-furnished laptop computer. Electrically isolate the port interface electronics from all monitor electronics, excluding Chassis Ground. Ensure that the controller can receive all event log information through a controller Asynchronous Communications Interface Adapter (Type 170E) or Async Serial Comm Module (2070L). Provide a Windows based graphic user interface software to communicate directly through the same monitor RS-232C/D compliant port to retrieve and view all event log information to a Department-furnished laptop computer. The RS-232C/D compliant port on the monitor shall allow the monitor to function as a DCE device with pin connections as follows:

| <b>Conflict Monitor RS-232C/D (DB-9 Female) Pinout</b> |                 |            |
|--|-----------------|------------|
| <b>Pin Number</b>                                      | <b>Function</b> | <b>I/O</b> |
| 1  | DCD             | O          |
| 2  | TX Data         | O          |
| 3  | RX Data         | I          |
| 4  | DTR             | I          |
| 5  | Ground          | -          |
| 6  | DSR             | O          |
| 7  | CTS             | I          |
| 8  | RTS             | O          |
| 9  | NC              | -          |



**MONITOR BOARD EDGE CONNECTOR**

| <b>Pin #</b> | <b>Function (Back Side)</b> | <b>Pin #</b> | <b>Function (Component Side)</b> |
|--------------|-----------------------------|--------------|----------------------------------|
| 1            | Channel 2 Green             | A            | Channel 2 Yellow                 |
| 2            | Channel 13 Green            | B            | Channel 6 Green                  |
| 3            | Channel 6 Yellow            | C            | Channel 15 Green                 |
| 4            | Channel 4 Green             | D            | Channel 4 Yellow                 |
| 5            | Channel 14 Green            | E            | Channel 8 Green                  |
| 6            | Channel 8 Yellow            | F            | Channel 16 Green                 |
| 7            | Channel 5 Green             | H            | Channel 5 Yellow                 |
| 8            | Channel 13 Yellow           | J            | Channel 1 Green                  |
| 9            | Channel 1 Yellow            | K            | Channel 15 Yellow                |
| 10           | Channel 7 Green             | L            | Channel 7 Yellow                 |
| 11           | Channel 14 Yellow           | M            | Channel 3 Green                  |
| 12           | Channel 3 Yellow            | N            | Channel 16 Yellow                |
| 13           | Channel 9 Green             | P            | Channel 17 Yellow                |
| 14           | Channel 17 Green            | R            | Channel 10 Green                 |
| 15           | Channel 11 Yellow           | S            | Channel 11 Green                 |
| 16           | Channel 9 Yellow            | T            | Channel 18 Yellow                |
| 17           | Channel 18 Green            | U            | Channel 10 Yellow                |
| --           |                             | --           |                                  |
| 18           | Channel 12 Yellow           | V            | Channel 12 Green                 |
| 19           | Channel 17 Red              | W            | Channel 18 Red                   |
| 20           | Chassis Ground              | X            | Not Assigned                     |
| 21           | AC-                         | Y            | DC Common                        |
| 22           | Watchdog Timer              | Z            | External Test Reset              |
| 23           | +24VDC                      | AA           | +24VDC                           |
| 24           | Tied to Pin 25              | BB           | Stop Time (Output)               |
| 25           | Tied to Pin 24              | CC           | Not Assigned                     |
| 26           | Not Assigned                | DD           | Not Assigned                     |
| 27           | Relay Output, Side #3, N.O. | EE           | Relay Output,Side #2,Common      |
| 28           | Relay Output, Side #1, N.C. | FF           | AC+                              |

-- Slotted for keying between Pins 17/U and 18/V

**CONFLICT PROGRAM CARD PIN ASSIGNMENTS**

| <b>Pin #</b> | <b>Function (Back Side)</b> | <b>Pin #</b> | <b>Function (Component Side)</b> |
|--------------|-----------------------------|--------------|----------------------------------|
| 1            | Channel 2 Green             | A            | Channel 1 Green                  |
| 2            | Channel 3 Green             | B            | Channel 2 Green                  |
| 3            | Channel 4 Green             | C            | Channel 3 Green                  |
| 4            | Channel 5 Green             | D            | Channel 4 Green                  |
| 5            | Channel 6 Green             | E            | Channel 5 Green                  |
| 6            | Channel 7 Green             | F            | Channel 6 Green                  |
| 7            | Channel 8 Green             | H            | Channel 7 Green                  |
| 8            | Channel 9 Green             | J            | Channel 8 Green                  |
| 9            | Channel 10 Green            | K            | Channel 9 Green                  |
| 10           | Channel 11 Green            | L            | Channel 10 Green                 |
| 11           | Channel 12 Green            | M            | Channel 11 Green                 |
| 12           | Channel 13 Green            | N            | Channel 12 Green                 |
| 13           | Channel 14 Green            | P            | Channel 13 Green                 |
| 14           | Channel 15 Green            | R            | Channel 14 Green                 |
| 15           | Channel 16 Green            | S            | Channel 15 Green                 |
| 16           | N/C                         | T            | PC AJAR                          |
| 17           | Channel 1 Yellow            | U            | Channel 9 Yellow                 |
| 18           | Channel 2 Yellow            | V            | Channel 10 Yellow                |
| 19           | Channel 3 Yellow            | W            | Channel 11 Yellow                |
| 20           | Channel 4 Yellow            | X            | Channel 12 Yellow                |
| 21           | Channel 5 Yellow            | Y            | Channel 13 Yellow                |
| 22           | Channel 6 Yellow            | Z            | Channel 14 Yellow                |
| 23           | Channel 7 Yellow            | AA           | Channel 15 Yellow                |
| 24           | Channel 8 Yellow            | BB           | Channel 16 Yellow                |
| --           |                             | --           |                                  |
| 25           | Channel 17 Green            | CC           | Channel 17 Yellow                |
| 26           | Channel 18 Green            | DD           | Channel 18 Yellow                |
| 27           | Channel 16 Green            | EE           | PC AJAR (Program Card)           |
| 28           | Yellow Inhibit Common       | FF           | Channel 17 Green                 |

-- Slotted for keying between Pins 24/BB and 25/CC

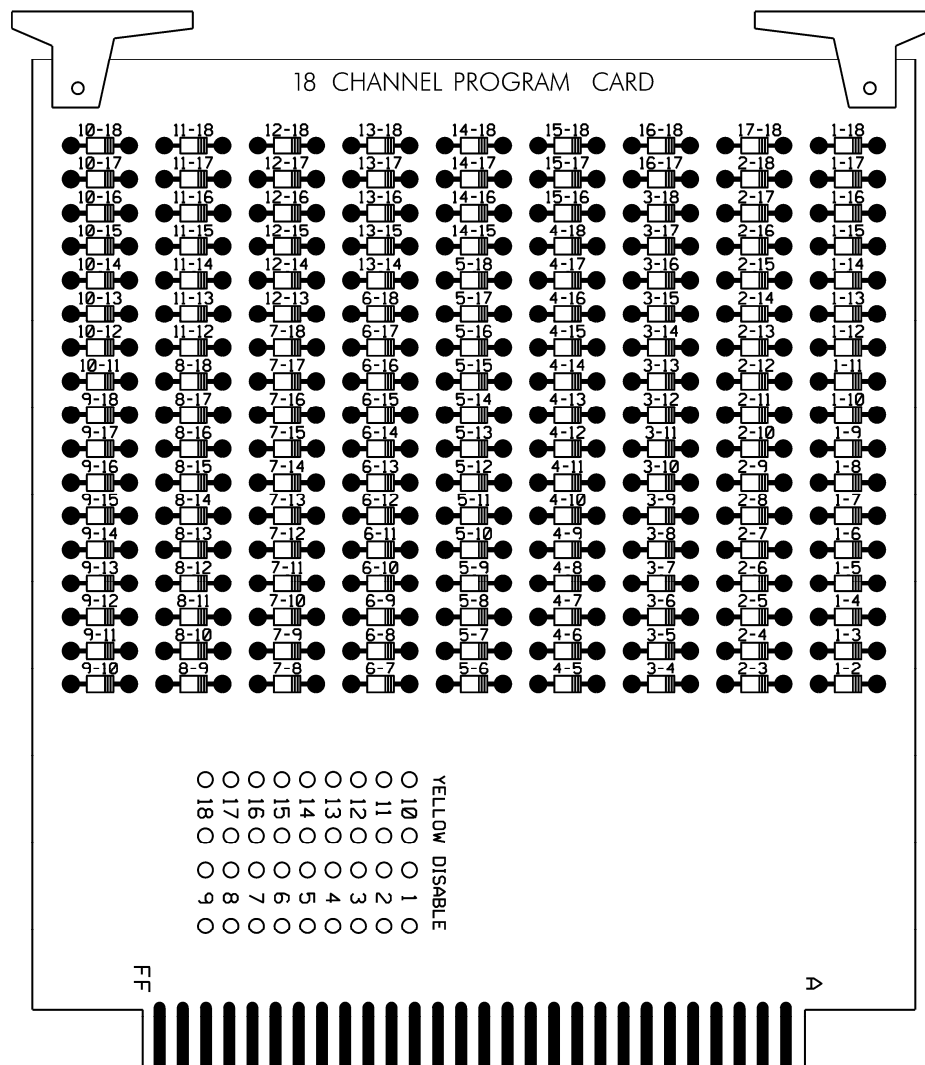

**E. Preemption and Sign Control Box**

Provide preemption and sign control box to operate in a Model 332 and Model 336S cabinet. Provide hardware to mount the box to the cage of the cabinet to ensure the front side is facing the opposite side of the cabinet. Furnish the material of the box from a durable finished metallic or thermoplastic case. Ensure the size of the box is not greater than 7(l) x 5(w) x 5(d) inches. Ensure that no modification is necessary to mount the box on the cabinet cage.

Provide the following components in the preemption and sign control box: relays, fuses, terminal blocks, MOVs, resistor, RC network, lamp, and push button switch.

Provide UL Listed or Recognized relay K1 as a DPDT enclosed relay (120 VAC, 60 Hz coil) with an 8-pin octal-style plug and associated octal base. Provide contact material made of AgCdO with a 10 amp, 240 VAC rating. Ensure the relay has a specified pickup voltage of 102 VAC.

Provide relay SSR1 as a Triac SPST normally open solid state relay that is rated for 120 VAC input and zero-crossing (resistive load) 25 amp @ 120 VAC output. Ensure the relay turns on at 90 Vrms within 10 ms and turns off at 10 Vrms within 40 ms. Ensure the relay has physical

characteristics as shown in the wiring detail in Figure 1. Provide 4 terminal screws with saddle clamps.

Provide fuses F1 and F2 as a UL Listed ¼" x 1-1/4" glass tube rated at 250 volts with a 10kA interrupting rating. Ensure F1 non-delay (fast-acting) and F2 slow-blow (time-delay) fuses have a maximum opening times of 60 minutes and 120 seconds for currents of 135 and 200 percent of the ampere rating, respectively. Ensure F2 slow-blow (time-delay) fuses have a minimum opening times of 12 seconds at 200 percent of the ampere rating. Provide fuse holders that are UL Recognized panel-mounted holders rated 250V, 15 ampere minimum with bayonet-type knobs which accept ¼" x 1-1/4" glass tube fuses.

Provide terminal blocks that are rated for 300V and are made of electrical grade thermoplastic or thermosetting plastic. Ensure each terminal block is of closed back design and has recessed-screw terminals with molded barriers between terminals. Ensure each terminal block is labeled with a block designation. Ensure each terminal is labeled with the function and a number.

Provide 3/4-inch diameter radial lead UL-recognized metal oxide varistors (MOVs) that have electrical performance as outlined below.

| <b>PROPERTIES OF MOV SURGE PROTECTOR</b>     |                          |
|--|--------------------------|
| Maximum Continuous Applied Voltage at 185° F | 150 VAC (RMS)<br>200 VDC |
| Maximum Peak 8x20µs Current at 185° F        | 6500 A                   |
| Maximum Energy Rating at 185° F              | 80 J                     |
| Voltage Range 1 mA DC Test at 77° F          | 212-268 V                |
| Max. Clamping Voltage 8x20µs, 100A at 77° F  | 395 V                    |
| Typical Capacitance (1 MHz) at 77° F         | 1600 pF                  |

Provide resistor R1 as a 2K ohm, 12 watt, wirewound resistor with tinned terminals and attaching leads. Ensure the resistor is spaced apart from surrounding wires.

Provide a LED or incandescent lamp that has a voltage rating of 120 VAC with a minimum life rating at 50,000 hours.

Wire the preemption and sign control box as shown in Figure 1.

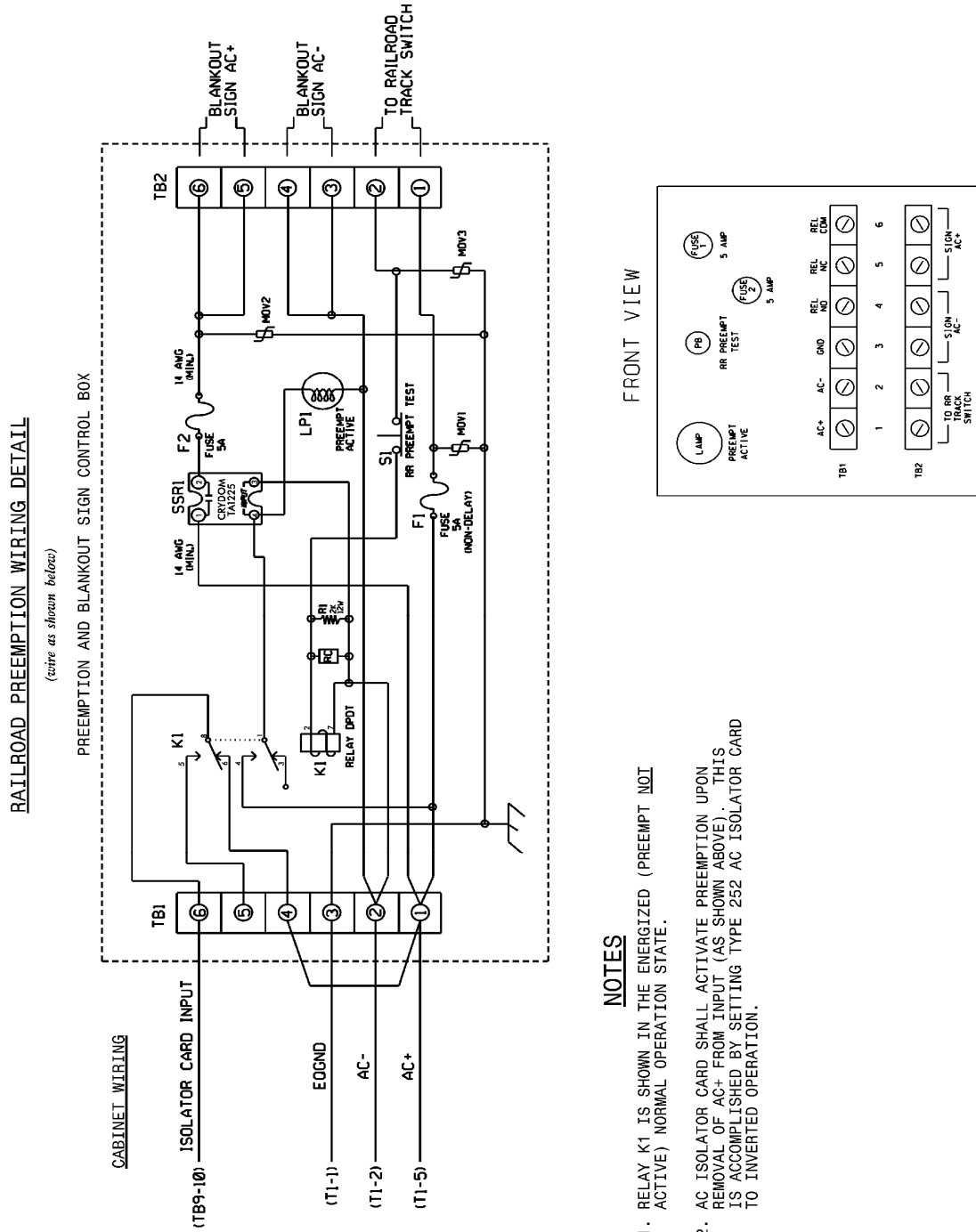

**NOTES**

1. RELAY K1 IS SHOWN IN THE ENERGIZED (PREEMPT NOI ACTIVE) NORMAL OPERATION STATE.
2. AC ISOLATOR CARD SHALL ACTIVATE PREEMPTION UPON REMOVAL OF AC+ FROM INPUT (AS SHOWN ABOVE). THIS IS ACCOMPLISHED BY SETTING TYPE 252 AC ISOLATOR CARD TO INVERTED OPERATION.

Figure 1

**12.7. MATERIALS – NEMA TS-1 CABINETS**

**A. NEMA TS-1 Cabinet Physical Requirements:**

Furnish unpainted, natural, aluminum cabinet shells. Ensure that all non-aluminum hardware on the cabinet is stainless steel or a Department approved non-corrosive alternate. Provide a roof with a slope from front to back at a minimum ratio of 1-inch drop per 2 feet. Ensure that each exterior cabinet plane surface is constructed of a single sheet of aluminum and is seamless.

Provide a handle and three point latching mechanism designed to be disassembled using hand tools. Provide a shaft connecting the latching plate to the door handle by passing through the door within a bushing, bearing, or equivalent device. Provide a latching plate at least 3/16 inch thick and that mates securely with the lock bolt. Provide a lock bolt with a flat end (no bevel) and that has at least 1/4 inch of length in contact with the latching plate.

Ensure that the handle and lock are positioned so that the lock does not lie in the path of the rotating handle as the door is unlatched and that the handle points down in the latched position.

Provide a cabinet that is neat in appearance. Provide continuous welds made from the inside wherever possible. On the exterior, provide smooth and flush joints. Ensure there are no superfluous holes in the outside of the cabinet. Ensure that no screws, bolts, nuts or rivets protrude to the outside of the cabinet shell. Ensure cabinet surface is smooth and free of blemishes and discoloration.

Provide a main door opening that encompasses the full frontal area of the cabinet shell exclusive of the area reserved for plenums and flanges. Provide a rear door in base-mounted cabinets, unless otherwise specified. Ensure that the rear door complies with all requirements for the front door, except as follows:

- Hinge rear door on the left side as viewed from the rear of the cabinet shell facing the door.
- No police compartment is required on a rear door.

Ensure that the cabinet shell is sturdy and does not exhibit noticeable flexing, bending or distortion under normal conditions except that a minor amount of flexing is permitted in the main door and rear door only when the cabinet is open. In such case, the flexing must not result in permanent deformation of the door or damage to components mounted on the door. Ensure that pedestal-mounted cabinets have sufficient framing around the slipfitter attachment so that no noticeable flexing will occur at or about this point.

Ensure that the cabinet is large enough to accommodate all of the required equipment, specified future equipment, and wiring within the cabinet to provide sufficient room for servicing. Provide ample space in the bottom of the cabinet for the entrance and forming of all necessary wires and cables without interference with the operation, viewing, and servicing of the equipment. Ensure that the size of the cabinet permits all required and specified future equipment to be mounted in the upright position with sufficient space around it to provide adequate ventilation. Ensure at least 2 inches of clearance is provided around all vents and fans to insure proper air circulation. Ensure the interior size of the cabinets is at least:

|   |                      |
|---|----------------------|
| Pole- and pedestal-mounted controller cabinets:       | 4.98 ft <sup>3</sup> |
| Base-mounted controller cabinets:                     | 11.6 ft <sup>3</sup> |
| Pole- and pedestal-mounted on-street master cabinets: | 3.5 ft <sup>3</sup>  |
| Base-mounted on-street master cabinets:               | 7.52 ft <sup>3</sup> |

If specified on the bid list or the plans, controller cabinets as small as 3.3 ft<sup>3</sup> may be provided for pole- and pedestal-mounted cabinets provided all other requirements are satisfied. Unless otherwise noted, ensure that cabinets do not exceed the following dimensions:

**Maximum Outside Dimensions**

| <b>Type of Cabinet</b> | <b>Height</b> | <b>Width</b> | <b>Depth</b> |
|------------------------|---------------|--------------|--------------|
| Pole-mounted           | 52 inches     | 30 inches    | 22 inches    |
| Pedestal-mounted       | 36 inches     | 30 inches    | 22 inches    |
| Base-mounted           | None          | None         | None         |

Provide at least 2 sturdy shelves having an unobstructed depth of at least 13 inches. Ensure top shelf is at least 12 inches below the top of the door opening. Secure any card rack to the walls or shelves. Ensure equipment and components mounted on the cabinet walls require no more than the use of a screwdriver to accomplish their easy removal for servicing. Ensure shelf-mounted units are placed in their proper positions on the shelves without having to twist or turn them during the placement process.

Provide a minimum 12 x 14 inch plastic envelope or container located in the cabinet so that it is convenient for service personnel. Furnish two sets of non-fading cabinet wiring diagrams and schematics in a paper envelope or container and placed in the plastic envelope or container.

Provide a roof with a shield that prevents water from dripping into the cabinet. Equip the roof with a thermostatically controlled exhaust fan and suitably screened exhaust vents that will permit the flow of air for which the fan is rated. Ensure that base-mounted cabinets have a fan rated for at least 12 gal./s and pole- and pedestal-mounted cabinets have a fan rated for at least 6 gal./s. Ensure that the fan does not protrude to the outside of the cabinet and that it is mounted in such a way that it can be easily removed for servicing. Fusing the fan is not required. Ensure that the roof assembly is formed in such a way that it facilitates air exhaust from the fan.

Provide an additional vent or vents at or near the bottom to permit the intake of air. Ensure that the size of the vents permit the flow of air corresponding to the rated flow of the fan. Ensure that the vents are not smaller than 29.45 in<sup>2</sup>. Equip the vents with standard-size replaceable fiberglass filters. Ensure that the vents do not permit the entrance of rain or snow.

Furnish a fluorescent fixture as required by NEMA TS-2 Specifications with a second lighting fixture mounted under the bottom shelf to light the terminals. Ensure that the second fixture is a fluorescent lighting fixture that complies with NEMA TS-2 Specifications or is a flexible gooseneck fixture containing a protected incandescent reflector bulb of a least 25 Watts. Furnish all bulbs. Ensure that the lamps are door switch actuated.

Provide the cabinet with an adjustable thermostat located in the upper portion of the inside the roof and connected to control the fan. Ensure that it is manually adjustable within the range of at least 78 to 170 degrees F with a calibrated scale. Ensure that the thermostat has contacts rated for use with the fan. Ensure that the thermostat turns the fan on at the set temperature and turns it off when the temperature is 4.5 degrees F below the set temperature.

Provide sufficient electrical and electronic noise suppression in the cabinet to enable all equipment in it to function properly. Ensure cabinet is equipped with one or more radio interference filters connected between the stages of the power line surge protector. Ensure filter(s) minimize interference generated in the cabinet in both the broadcast and aircraft frequencies. Ensure filter(s)

provide attenuation of at least 50 decibels over a frequency range of 200 kilohertz to 75 megahertz. Provide filters that are hermetically sealed in metal cases and are insulated. Ensure filter is rated at least at the rated current of the main circuit breaker, 125-volt, 60 Hertz.

**B. NEMA TS-1 Cabinet Electrical Requirements:**

Provide duplex receptacle in the cabinet located conveniently for service personnel and in such a position that no electrical hazard will be presented to such personnel when using the receptacle. Ensure that the receptacle is a 3-wire ground fault interrupt type that will also accept a standard 2-prong, non-grounding plug. Ensure that the receptacle is reserved for the use of service personnel. Ensure normal control cabinet equipment is not connected to the receptacle.

Provide the cabinet with a NEMA standard circuit breaker box having at least two circuit breakers. Alternatively, provide circuit breakers that are installed in such a way that personnel servicing the cabinet, including the rear of the back panel, cannot inadvertently be exposed to a hazard. Ensure that a terminal block connected to the circuit breakers accommodates service wire as large as Number 6 AWG. Ensure that these circuit breakers are in addition to any fuses that are a part of the individual control equipment components. Provide a clear plastic guard or the equivalent to prevent incidental contact and shock hazard that protects exposed 120-volt AC terminals on the power panel.

Provide a cabinet with a ground bus having at least 20 terminals. Ensure that the bus is attached and electrically bonded to the wall of the cabinet and located conveniently to the traffic signal load circuits. Provide terminals to accommodate Number 10, 12, and 14 AWG conductors. Ensure that at least one terminal on each end is grounded and accommodates a Number 4 AWG conductor.

Provide a cabinet with an AC Neutral bus having at least 24 terminals. Ensure bus is isolated electrically from the cabinet ground. Provide terminals to accommodate Number 10, 12, and 14 AWG conductors. Ensure bus bar is conveniently located near the traffic signal load circuits.

Provide surge suppression in the cabinet and ensure that all devices operate over the temperature range of -40 to 185 degrees F.

Provide a loop surge suppresser for each set of loop terminals in the cabinet. Use terminal mount or stud mount devices for terminating the loop surge suppresser. Ensure that the device can withstand a minimum of 25 peak surge current occurrences at 100A in differential and common modes for a 10x700 microsecond waveform. Ensure that the maximum breakover voltage is 170V and the maximum on state clamping voltage is 30V. Provide a maximum response time less than 5 nanoseconds and an off state leakage current less than 10 $\mu$ A with a nominal capacitance less than 220pf for both differential and common modes.

Provide surge suppression on each communications line entering or leaving a cabinet. Ensure that the communications surge suppresser can withstand at least 80 occurrences of an 8x20 microsecond waveform at 2000A, or a 10x700 microsecond waveform at 400A. Provide a maximum clamping voltage suited to the equipment protected. Provide a maximum response time less than 1 nanosecond with a nominal capacitance less than 1500pf and a series resistance less than 15 $\Omega$ .

Ensure that no direct inter-equipment connection is made. Ensure that all equipment is connected to other items of equipment at the cabinet terminal blocks.

Provide the capability for each item of equipment from the cabinet to be removed without disconnecting individual wires. Provide the equipment with suitable MS-type or other multi-pin connectors, or mount in card racks that provide for automatic connection of the card when it is



inserted in the rack. Ensure that connectors for the controller A, B and C harnesses, for shelf-mounted detectors and for conflict monitors are metal and separately bonded to the chassis.

Ensure that functionally equivalent equipment is electrically and mechanically interchangeable.

Ensure that all equipment and circuit cards are designed or keyed so that it is physically impossible to connect the unit to the wrong connector or insert it into an incorrect slot. Equip the cabinet with terminal blocks (strips) for the termination of all field conductors and all internal wires and harness conductors. Ensure that all wires are terminated at the terminals. Provide field terminals that are readily accessible without the removal of equipment and located conveniently to the wires, cables and harnesses. Ensure that each terminal block is of electrical grade thermoplastic or thermosetting plastic and each terminal block is a closed back design and has recessed-screw terminals with molded barriers between the terminals.

Ensure that each terminal of a terminal block consists of two terminal screws with a removable shorting bar between them. However, if the terminal block is part of a fabricated panel, each terminal may consist of a single terminal screw with a feed-through binding post to which conductors are soldered behind the panel. Exception: Terminal blocks used for field wiring connections are not required to have removable shorting bars unless required by a specific manufacturer's design. Ensure that each terminal block is labeled with a block designation and each terminal is labeled with a number. Ensure that all terminal functions are also labeled on the back panel or terminal blocks. Provide labels that are visible when the terminal block is fully wired. Ensure that the labels are shown on the cabinet wiring diagrams. Ensure that no terminals are closer than 4 inches to the bottom of the cabinet and provide those in base-mounted cabinets at least 6 inches from the bottom. Ensure that terminals serving similar functions are grouped together. Ensure that no terminals are located on the under side of shelves or at other places where they are not readily visible and accessible or where they may be a hazard to personnel who might inadvertently touch them. Provide police panel, if required, with an enclosure over the terminals of its components to prevent hazard to personnel. Cardboard and other types of flexible covers are not acceptable.

Ensure all equipment in the cabinet is connected to the cabinet, to the other items of equipment, and to the field circuits at the cabinet terminal blocks by means of neatly trained harnesses.

Provide harnesses in the cabinet for non-permanently mounted equipment that are long enough to allow the equipment to be relocated in an upright position to the roof of the cabinet or to be located to the ground 12 inches below cabinet level. Provide a secondary ground conductor of sufficient size to safely carry any fault current for harnesses that supply power or an AC+ input greater than 24 volts. Ensure that all harnesses are neatly dressed along the cabinet walls either parallel to or perpendicular to the floor. Ensure that they do not run diagonally. Ensure that the harness, which connects the components on the door to the remainder of the cabinet does not touch the doorjamb in any door position, including fully open.

Ensure that each conductor, including unused conductors, within or entering the cabinet is connected to a terminal. Ensure that no more than two conductors are connected to any single terminal screw with the following exception. Multiple conductors may be attached to a terminal used to distribute AC and DC power functions (AC+, AC-, Earth Ground, 24VDC, Logic Ground, etc.) or similar multi-use signals under the following conditions:

- it is unlikely that the conductors attached to such terminals will be removed by the cabinet user and,

## Signals &amp; Intelligent Transportation Systems

- there exists at least one terminal for each of the functions that has two or fewer conductors connected to it that is available for customer use.

This exception does not alter other requirements in these specifications that define the required number of terminals for power or other specific circuits. This provision does not apply to terminals on the load side of the load switches.

Ensure that each conductor has a crimped spade lug when connected to a terminal screw. Terminations to the back panel may be soldered. Connections such as quick connectors and barrel connectors are not acceptable. No in-line splices are permitted in any conductor.

Ensure outgoing circuits are of the same polarity as the line side of the AC supply. Ensure that the common return is of the same polarity as the grounded side of the AC supply.

Ensure all wiring is formed into neatly packaged and neatly dressed harnesses and laced, braided or tied with nylon tie wraps at closely spaced intervals. Where wires, cables or harnesses must be attached to the cabinet walls or door for support or to prevent undue wear or flexing, ensure attachment is made using nylon tie straps or metal clamps with rubber or neoprene insulators. Ensure that these attachment devices are screwed to the cabinet. Stick-on clamps or straps are not permitted.

Ensure that all field wiring and all internal conductors that are likely to be disconnected from time to time are tagged with non-fading, permanent sleeve labels at the ends of the conductors at the terminals. Ensure that sleeve labels are shrunk tightly to grip the conductors. Alternatively, hot stamp labels on the insulation of internal conductors at intervals of no greater than 4 inches. Ensure that all jumpers are wire conductors or metal plates. Using printed circuit back panels or back panels with wire tracks on boards are not permitted.

Provide 3 terminals (2 for loop conductors and 1 for shield) for each loop shown on the plans or required by the bid list. As a minimum, ensure cabinet provides sufficient terminals for 4 loops and detectors in Type 2 cabinets, 8 loops and detectors in Type 4 cabinets, and 16 loops and detectors in Type 8 cabinets. Provide a loop detector surge protector connected to each detector loop input.

Furnish the cabinet with a neatly labeled test switch panel mounted on the inside of the cabinet door. Ensure that the panel contains the following components that are connected to provide the functions indicated. Unless otherwise required, provide switches that are heavy-duty toggle switches.

- 1) **Detector Circuit Test Switch:** Ensure each detector circuit test switch is a three-position (on-normal-momentary on) switch. Ensure each switch is connected to the controller's or communications unit's detector input and in parallel with its associated detector's output so service personnel can place both momentary and constant calls on the device to be actuated. When in the normal position (center position), ensure switch has no effect on the device to be actuated. In all cases, the detector is to remain connected to the device to be actuated. Provide a detector circuit test switch for each vehicle detector input connected to the controller and each pedestrian detector input to the controller regardless of how many of the controller's phases are in use. In addition, provide detector circuit test switches connected to the system detector inputs of the communications unit if required by the plans or the bid list. As a minimum, provide the following numbers of switches:

| <b>Type of Cabinet</b> | <b>Vehicle</b>           | <b>Pedestrian</b>        |
|------------------------|--------------------------|--------------------------|
|                        | <b>Detector Switches</b> | <b>Detector Switches</b> |
| Type 2 cabinet         | 2                        | 2                        |
| Type 4 cabinet         | 4                        | 4                        |
| Type 8 cabinet         | 8                        | 4                        |

- 2) **Technician Flash Switch:** Provide the test switch panel with a toggle switch for switching the intersection operation between normal stop-and-go (AUTO) operation and flashing operation. Protect this switch against accidental activation by a flip-up switch guard that does not affect switch position when closed.
- 3) **Controller Power Switch:** Provide a test switch panel that contains a toggle switch connected to remove power from the controller and all auxiliary equipment but ensure it does not interrupt power to the flasher. Ensure that this switch is protected against accidental activation by a flip-up switch guard that does not affect switch position when closed.
- 4) **Preemption Test Switches:** Provide a preemption test switch for each distinct preemption operation required by the plans or the bid list. Ensure that the switch is located on the inside of the door or on the left or right inside wall of the cabinet at an easily accessible location. Ensure that the switch is protected against accidental activation by a flip-up switch guard that does not affect switch position when closed.

Provide the cabinet with a police panel that is furnished with the indicated components connected:

- 1) **Police Panel Construction:** Provide a police panel with a door on it in the main door that is accessible when the main door is closed and will not allow water to enter the cabinet when the police door is open. Ensure that the police panel door is hinged on the right side as viewed facing it and has a lock that is keyed with two furnished keys and keyed to a standard police/fire call box key for each cabinet.
- 2) **Emergency Flash Switch:** Provide the police panel with a toggle switch for switching the intersection operation between normal stop-and-go (AUTO) operation and flashing operation.
- 3) **Signal Switch:** Provide the police panel with a toggle switch connected to permit power to be turned on and off to the field signal indicators. When in the off position, ensure that the power it removes is from the field signal indicators and that the controller and all equipment in the cabinet continue to operate normally.
- 4) **Automatic/Manual Switch:** Provide the police panel with a toggle switch connected to switch the intersection operation between normal stop-and-go operation (AUTO) and manual operation (MANUAL) using a hand control. Ensure that the manual control is implemented using only the Manual Control Enable and Interval Advance functions of the controller.
- 5) **Hand Control:** Provide a hand control with each cabinet for the police panel if specifically required by the plans or the bid list. Provide the hand control as a standard traffic signal manual control push-button connected on one end of a 10 feet coil cord with a 1/4 inch locking phone plug on the other end. Provide a locking phone jack in the police panel for this hand control to effect manual control of the intersection as described above. Ensure the plug and jack lock

together so they will not disconnect even when the cord is stretched to its limit. Ensure police panel has room for storage of the hand control.

Provide the cabinet with one or as many as needed solid state flashers to operate the signal displays when the intersection is operated in the flashing mode. Provide the cabinet with a flasher socket for each flasher and make it part of the cabinet back panel. Ensure that the cabinet is wired so that it is possible to select either flashing red or flashing yellow for each signal circuit by switching a jumper plug on the back panel or by switching jumpers using simple hand tools. Ensure that disassembly of and access to the rear of the back panel is not required to effect a flash color change. Ensure that movement of no more than three jumpers is required to change the flash color for any signal circuit. Ensure that the cabinet is wired to effect the switch between normal stop-and-go operation and flashing operation. Provide the following flashing operation:

- Ensure that the controller controls the planned change from stop-and-go operation to flashing operation.
- Ensure that upon actuation of the emergency flash switch in the police panel or the technician flash switch in the test switch panel or upon command of the conflict monitor, the signal indicators are disconnected from the load switches and the appropriate signal indicators are connected to flashing power. Ensure all other signal indicators are dark. Ensure this change takes place immediately upon actuation regardless of the signal indicators being displayed.
- Regardless of the mode of entry into flashing operation, ensure that the return to normal stop-and-go operation occurs only when the controller begins to time the major street WALK interval (green interval if WALK is not used). Ensure that this is accomplished via the activation of the external start input.
- Ensure that the operation of the intersection controller is not affected when the technician flash switch or the communications unit initiates flashing operation, if any, and the controller continues to operate normally. Ensure that the controller stops timing when actuated by the emergency flash switch or the conflict monitor.

Furnish all cabinets, except pretimed cabinets, with optical isolation circuits connected between the pedestrian push-buttons and the pedestrian detector inputs of the controllers and the two-pulse pedestrian detector logic units, if any. Ensure all electronic components for the isolation circuits are contained on a circuit board that can be easily disconnected from its receptacle. Provide isolation circuits for the following number of pedestrian detector circuits:

|                 |   |
|-----------------|---|
| Type 2 cabinet: | 2 |
| Type 4 cabinet: | 4 |
| Type 8 cabinet: | 4 |

Ensure that the voltage present at the pedestrian push-buttons does not exceed 24 volts.

### **C. NEMA TS-1 Conflict Monitors:**

Furnish NEMA TS-1 conflict monitor with programming card. Ensure that the absence of the programming card will cause the conflict monitor to trigger, and remain in the triggered state until reset.

Provide a conflict monitor that recognizes the following faults in addition to those specified by NEMA TS-1 Section 6. Ensure that the conflict monitor will trigger as required by the NEMA Specifications:

- Yellow indication missing or shorter than 2.7 seconds (with  $\pm 0.1$  second accuracy);
- Walk indication without green vehicle indication on same channel;
- Dual Indications on the same channel.

Ensure that the tests for short and missing yellows and for dual indications be turned on or off per channel. Ensure that the test for walk without green be selectable for each unit. If one of the additional optional fault tests are enabled and an associated fault is detected, ensure that the conflict monitor remains in the triggered state until the unit is reset unless otherwise specified.

When the conflict monitor is triggered, provide a visual indication of the type of event that triggered the unit. Ensure that these indications and the status of each channel be retained until the conflict monitor is reset.

Ensure that the conflict monitor allows user selected latching of the CVM, 24V I, and 24V II inputs. When the conflict monitor is set for latching operation and one of these events is triggered, ensure that the monitor is reset before returning to normal operation.

Provide nonvolatile memory in the conflict monitor that retains a log of events containing the failure type, channel status, date, time for the nine most recent faults, and the date and time of the ten most recent power failures at a minimum. Ensure that the conflict monitor outputs the event log on request to a printer and uploads the event log on request to a Department-furnished personal computer via the RS-232C serial port. Provide the RS-232C serial port mounted on the front.

Provide a conflict monitor with the number of channels required by the plans or bid list. Where required by the plans or bid list, ensure that the conflict monitor is supplied with a wiring harness set. Ensure that the harness is fitted with the proper connector and the harness is 10 feet in length.

## **12.8. MATERIALS – NEMA TS-2 TYPE 1 CABINETS**

### **A. NEMA TS-2 Type 1 Cabinets General:**

Comply with the *NEMA Standards Publication TS-2* (NEMA TS-2) except as otherwise stated herein.

Furnish unpainted, natural, aluminum cabinet shells that comply with Section 7 of NEMA TS-2. Ensure all non-aluminum hardware on the cabinet is stainless steel or a Department approved non-corrosive alternate. Provide a roof with a slope from front to back at a minimum ratio of 1 inch drop per 2 feet. Ensure that each exterior cabinet plane surface is constructed of a single sheet of aluminum and is seamless.

Ensure all components are arranged for easy access during servicing. When modular in construction, provide guides and positive connection devices to insure proper pin alignment and connection.

Provide a moisture resistant coating on all circuit boards.

### **B. NEMA TS-2 Type 1 Cabinet Physical Requirements:**

Provide a handle and three point latching mechanism designed to be disassembled using hand tools. Provide a shaft connecting the latching plate to the door handle by passing through the door

within a bushing, bearing, or equivalent device. Provide a latching plate at least 3/16 inch thick and that mates securely with the lock bolt. Provide a lock bolt with a flat end (no bevel) and that has at least 1/4 inch of length in contact with the latching plate.

Ensure that the handle and lock are positioned so that the lock does not lie in the path of the rotating handle as the door is unlatched and that the handle points down in the latched position.

Provide continuous welds made from the inside wherever possible. On the exterior, provide smooth and flush joints. Ensure that no screws, bolts, or rivets protrude to outside of cabinet shell.

Provide a main door opening that encompasses the full frontal area of the cabinet shell exclusive of the area reserved for plenums and flanges. Provide a rear door in base-mounted cabinets, unless otherwise specified. Ensure that the rear door complies with all requirements for the front door, except as follows:

- \* Hinge the rear door on the left side as viewed from the rear of the cabinet shell facing the door.
- \* No police compartment is required on a rear door.

Ensure that the cabinet shell is sturdy and does not exhibit noticeable flexing, bending or distortion under normal conditions except that a minor amount of flexing is permitted in the main door and rear door only when the cabinet is open. In such case, the flexing must not result in permanent deformation of the door or damage to components mounted on the door. Ensure that pedestal-mounted cabinets have sufficient framing around the slipfitter attachment so that no noticeable flexing will occur at or about this point.

Provide NEMA TS-2, Type 1 cabinets with 2 shelves. Ensure top shelf has an unobstructed depth of at least 12 inches for base-mounted cabinets. Ensure top shelf has an unobstructed shelf depth of at least 13 inches for pole-mounted cabinets. Locate the top shelf at least 12 inches below the top of the door opening. Provide a lower shelf for mounting detector racks, its associated BIU, and other auxiliary equipment. Locate the lower shelf at least 10 inches below the top shelf, and provide at least 13 inches of unobstructed shelf depth. Secure card racks and associated BIU connector housings to the shelf by a removable means. Place the rack so that the front of the rack is not obscured by any object and so that backpanel terminals are not obscured even when the rack is fully utilized.

Provide a back panel hinged at the bottom for access during service.

Provide a minimum 12 x 14 inch plastic envelope or container located in the cabinet so that it is convenient for service personnel.

Furnish two sets of non-fading cabinet wiring diagrams and schematics in a paper envelope or container and placed in the plastic envelope or container.

Do not locate permanently mounted equipment in such a way that will restrict access to terminals.

### **C. NEMA TS-2 Type 1 Cabinet Electrical Requirements:**

Provide a neutral that is not connected to the earth ground or the logic ground anywhere within the cabinet. Ensure the earth ground bus and the neutral ground bus each have ten compression type terminals each of which can accommodate wires ranging from number 14 through number 4.

**TIP Number****County Name**

## Signals &amp; Intelligent Transportation Systems

Provide surge suppression in the cabinet and ensure that all devices operate over the temperature range of -40 to 185 degrees F.

Provide a loop surge suppresser for each set of loop terminals in the cabinet. Use terminal mount or stud mount devices for terminating the loop surge suppresser. Ensure that the device can withstand a minimum of 25 peak surge current occurrences at 100A in differential and common modes for a 10x700 microsecond waveform. Ensure that the maximum breakover voltage is 170V and the maximum on-state clamping voltage is 30V. Provide a maximum response time less than 5 nanoseconds and an off-state leakage current less than 10  $\mu$ A. Ensure that a nominal capacitance less than 220pf for both differential and common modes.

Provide surge suppression on each communications line entering or leaving a cabinet. Ensure that the communications surge suppresser can withstand at least 80 occurrences of an 8x20 microsecond waveform at 2000A, or a 10x700 microsecond waveform at 400A. Provide a maximum clamping voltage suited to the equipment protected. Provide a maximum response time less than 1 nanosecond with a nominal capacitance less than 1500pf and a series resistance less than 15  $\Omega$ .

Furnish a fluorescent fixture as required by NEMA TS-2 Specifications with a second lighting fixture mounted under the bottom shelf to light the terminals. Ensure that the second fixture is a fluorescent lighting fixture that complies with NEMA TS-2 Specifications or is a flexible gooseneck fixture containing a protected incandescent reflector bulb of at least 25 Watts. Furnish all bulbs. Ensure that the lamps are door switch actuated.

Provide connector type harnesses for all equipment installed in the cabinet, including detector racks. Furnish a harness with connectors to adapt the NEMA TS-2, Type 2 controller "A" connector to the NEMA TS-2, Type 1 "A" connector furnished with the cabinet assembly.

Tag all conductors that are likely to be disconnected from time to time with non-fading, permanent sleeve labels at the ends of the conductors.

In cabinets that are not base mounted, have no terminals closer than 4 inches to the bottom of the cabinet.

Fasten all wiring and harness supports to the cabinet with screws or other removable mechanical means. Do not use adhesives.

Provide harnesses in the cabinet for non-permanently mounted equipment that are long enough to allow the equipment to be relocated in an upright position to the roof of the cabinet or to be located to the ground 1 foot below cabinet level.

Do not locate terminals on the underside of shelves or at other places where they are not readily visible and accessible, or where they may be a hazard to personnel. Provide a clear plastic guard for exposed 120 volt AC terminals on the power panel and the rear of terminal facilities accessible from the rear door.

Provide compression type earth grounds with 10 position terminal buses sized for four Number 14 AWG wires. Provide screw-type terminals for signal feed, detector lead-in, NEMA I/Os, backpanels, and interconnect terminals. Provide screw terminals for all other devices not defined by NEMA TS-2 Specifications. Ensure that wiring by the manufacturer is terminated either on double terminal strips with crimped-on lugs or soldered to rear terminals.

Ensure that upon leaving any cabinet or malfunction management unit (MMU) initiated flashing operation, the controller reverts to its programmed start-up operation through the use of the START

UP FLASH CALL feature. Do not require special controller software to implement the return from flash in the start up mode of operation. Wire one of the output relays of the MMU to apply a logic ground to the STOP TIME input for rings 1 and 2 when the MMU initiates flashing operation because of a sensed failure. Ensure that the MMU is interlocked within the cabinet control circuitry as to prevent normal signal operation with the MMU disconnected. Ensure that the 24Vdc supply to the load switches is disconnected when cabinet flashing operation is initialized. Provide a momentary pushbutton, or equivalent method, to apply 24Vdc to the load switches during cabinet flash for troubleshooting purposes.

Unless otherwise required, provide switches that are heavy-duty toggle switches.

Provide a technician panel mounted on the inside of the door with an EQUIPMENT POWER (ON/OFF) switch and an AUTO/FLASH switch. Ensure switches are protected against accidental activation by a flip-up switch guard that does not affect switch position when closed. Provide an EQUIPMENT POWER (ON/OFF) toggle switch that connects or disconnects protected equipment power to all devices in the cabinet and does not affect AC power to the flasher. Provide an AUTO/FLASH toggle switch which immediately places the intersection into flashing operation, disconnects the STOP TIME input generated by the MMU, and applies a logic ground to the LOCAL FLASH STATUS input of the MMU. When placed in the AUTO position, ensure that this switch causes the return of the intersection to normal operation at the programmed start up phases and intervals via the START-UP FLASH CALL feature of the controller unit. Provide a DETECTOR CHANNEL CALL three position detector test switch (on, normal, momentary on) installed for every detector channel in the detector racks. Provide four pedestrian detector test switches (on normal, momentary on) to the 4 pedestrian detector inputs of BIU no. 1. The switches may be installed on the door or on the non-door hinge side of the cabinet at the front of the cabinet.

Provide a police compartment constructed such that neither water nor dust will enter the interior of the cabinet through the police compartment, even when the police compartment door is open. Provide a rigid enclosure over the terminals of its components. Do not use flexible guards. Provide a SIGNAL POWER (ON/OFF) switch, an AUTO/FLASH switch, and an AUTO/MANUAL switch. Provide a locking jack for an optional manual push-button. Provide a SIGNAL POWER (ON/OFF) toggle switch which, when in the "OFF" position, disconnects AC power to the field terminals, applies logic ground to the LOCAL FLASH STATUS input of the MMU, and disconnects the STOP TIME input generated by the MMU. Ensure that a means to prevent recognition of red failure by the malfunction management unit is used and the switch does not affect power to equipment in the cabinet. When the SIGNAL POWER switch is switched to the "ON" position, ensure controller reverts to the programmed start-up phases and intervals via the START-UP FLASH CALL feature of the controller unit. Provide an AUTO/FLASH toggle switch that immediately places the intersection into flashing operation, and applies logic ground to the MMU LOCAL FLASH STATUS input. When placed in the AUTO position, ensure this switch allows the return of the intersection to normal operation at the programmed start-up phases and intervals via THE START-UP FLASH CALL feature of the controller unit. Provide an AUTO/MANUAL toggle switch that selects between normal operation (in the AUTO position) and manually controlled operation (in the MANUAL position). When in the MANUAL position, ensure that a logic ground is applied to the Manual Control Enable input of the controller. Ensure that only when a logic ground signal is applied to Manual Control Enable, the optional manual push-button can be used to advance the phases by applying and removing a logic ground signal to the Interval Advance input.



**TIP Number****County Name**

## Signals &amp; Intelligent Transportation Systems

Provide one flash transfer relay and flasher for each corresponding socket. Provide 2 spare terminals for each flasher circuit output. Provide 1 MMU and 1 cabinet DC power supply (shelf mounted) with all necessary harnesses wired to the appropriate cabinet/back panel termination points. Terminate unused MMU inputs. Provide BIUs with sockets and terminal facilities. BIUs 3 and 4 may be mounted in a rack separate from the back panel.

Provide a minimum of 2 sets of loop terminals and a single earth ground terminal between the 2 sets of loop wire terminals for each slot in each detector rack provided.

In cabinets with less than 16 loadbay positions, provide flash transfer relay circuits for load switches used to implement pedestrian signals that are brought out to separate terminals but not connected for flashing operation when pedestrian signals are assigned to the load switch channel. Ensure that the flash circuit inputs and outputs are available for easy connection to allow conversion of a pedestrian movement load switch for use as an overlap (vehicle phase) movement load switch. Provide a reserved flash transfer relay circuit for four vehicle movements and all necessary flash transfer relay input and output wiring and flash circuit wiring that can be made available at each pedestrian load switch position.

Comply with the applicable tables for the type of cabinet furnished:

**TS-2 Type 1 Cabinet Configurations**

| CABINET CONFIGURATION | LOAD SWITCH SOCKETS | FLASH RELAY SOCKETS | FLASHER SOCKETS | BIU'S REQUIRED (BACK PANEL/ DETECTOR) | DETECTOR RACK TYPE/ QUANTITY | TS-2 CABINET TYPE* |
|-----------------------|---------------------|---------------------|-----------------|---------------------------------------|------------------------------|--------------------|
| NC-1                  | 4                   | 2                   | 1               | 1/1                                   | 1/1                          | 4**                |
| NC-2                  | 8                   | 4                   | 1               | 1/1                                   | 2/1                          | 5                  |
| NC-3                  | 12                  | 6                   | 1               | 2/1                                   | 2/1                          | 6                  |
| NC-3A                 | 12                  | 6                   | 1               | 2/2                                   | 2/2                          | 6                  |
| NC-3B                 | 12                  | 6                   | 1               | 2/2                                   | 2/1<br>1/1                   | 6                  |
| NC-4                  | 12                  | 6                   | 1               | †3/1                                  | 2/1                          | 6                  |
| NC-4A                 | 12                  | 6                   | 1               | †3/2                                  | 2/2                          | 6                  |
| NC-4B                 | 12                  | 6                   | 1               | †3/2                                  | 2/1 1/1                      | 6                  |
| NC-5                  | 12                  | 6                   | 1               | ‡4/1                                  | 2/1                          | 6                  |
| NC-5A                 | 12                  | 6                   | 1               | ‡4/2                                  | 2/2                          | 6                  |
| NC-5B                 | 12                  | 6                   | 1               | ‡4/2                                  | 2/1<br>1/1                   | 6                  |
| NC-6                  | 16                  | 6                   | 1               | 2/2                                   | 2/2                          | 6                  |
| NC-6A                 | 16                  | 6                   | 1               | 2/2                                   | 2/1<br>1/1                   | 6                  |
| NC-7                  | 16                  | 6                   | 1               | †3/2                                  | 2/2                          | 6                  |
| NC-7A                 | 16                  | 6                   | 1               | †3/2                                  | 2/1<br>1/1                   | 6                  |
| NC-8                  | 16                  | 6                   | 1               | ‡4/2                                  | 2/2                          | 6                  |
| NC-8A                 | 16                  | 6                   | 1               | ‡4/2                                  | 2/1<br>1/1                   | 6                  |

\*See NEMA TS-2-1998, Table 7-1 for actual dimensions.

\*\*Type 5 cabinet may be substituted for four position base mount cabinet.

† BIU 3 required along with BIU 1, BIU 2, and detector BIU(s).

‡ BIU 3 and BIU 4 required along with BIU 1, BIU 2, and detector BIU(s).

**8-Position Loadbay Cabinet Phase Assignments**

| PHASE /OL NUMBER | MALFUNCTION MANAGEMENT UNIT CHANNEL ASSIGNMENT | ASSIGNED TO LOAD SWITCH POSITION NUMBER | ASSIGNED TO FLASH RELAY NUMBER | ASSIGNED TO FLASHER CIRCUIT/ | PROGRAM FLASH COLOR |
|------------------|--|---|--------------------------------|------------------------------|---------------------|
| 1                | 1  | 1                                       | 1                              | 1                            | R                   |
| 2                | 2  | 2                                       | 1                              | 2                            | Y                   |
| 3                | 3  | 3                                       | 2                              | 1                            | R                   |
| 4                | 4  | 4                                       | 2                              | 2                            | R                   |
| 2 PED-O/LA †     | 5  | 5                                       | †3                             | †1                           | D                   |
| 4 PED O/L .B†    | 6  | 6                                       | †3                             | †2                           | D                   |
| O/L C            | 7  | 7                                       | 4                              | 1                            | R                   |
| O/L D            | 8  | 8                                       | 4                              | 2                            | R                   |

† Prepare this load switch position for the pedestrian movement indicated. Wire pedestrian signals to flash dark. Make flash circuitry for this load switch position available and accessible at a separate terminal to allow connection to the load switch and field terminal circuit for a vehicle movement at a later date if desired.

**12-Position Loadbay Cabinet Phase Assignments**

| PHASE /OL NUMBER | MALFUNCTION MANAGEMENT UNIT CHANNEL ASSIGNMENT | ASSIGNED TO LOAD SWITCH POSITION NUMBER | ASSIGNED TO FLASH RELAY NUMBER | ASSIGNED TO FLASHER CIRCUIT/ | PROGRAM FLASH COLOR |
|------------------|--|---|--------------------------------|------------------------------|---------------------|
| 1                | 1  | 1                                       | 1                              | 1                            | R                   |
| 2                | 2  | 2                                       | 1                              | 2                            | Y                   |
| 3                | 3  | 3                                       | 2                              | 1                            | R                   |
| 4                | 4  | 4                                       | 2                              | 2                            | R                   |
| 5                | 5  | 5                                       | 3                              | 2                            | R                   |
| 6                | 6  | 6                                       | 3                              | 1                            | Y                   |
| 7                | 7  | 7                                       | 4                              | 2                            | R                   |
| 8                | 8  | 8                                       | 4                              | 1                            | R                   |

|                    |    |    |    |    |   |
|--------------------|----|----|----|----|---|
| 2 PED or O/L<br>A† | 9  | 9  | †5 | †1 | D |
| 4 PED or O/L<br>B† | 10 | 10 | †5 | †2 | D |
| 6 PED or O/C†      | 11 | 11 | †6 | †1 | D |
| 8 PED or O/L<br>D† | 12 | 12 | †6 | †2 | D |

† Prepare this load switch position for the pedestrian movement indicated. Wire pedestrian signals to flash dark. Make flash circuitry for this load switch position available and accessible at a separate terminal to allow connection to the load switch and field terminal circuit for a vehicle movement at a later date.

**16 Position Loadbay Cabinet Phase Assignments**

| PHASE /OL<br>NUMBER | MALFUNCTION<br>MANAGEMENT UNIT<br>CHANNEL<br>ASSIGNMENT | ASSIGNED TO<br>LOAD SWITCH<br>POSITION<br>NUMBER | ASSIGNED<br>TO<br>FLASH<br>RELAY<br>NUMBER | ASSIGNED<br>TO FLASHER<br>CIRCUIT/<br>CIRCUIT/ | PROGRAM<br>FLASH<br>COLOR |
|---------------------|---|--|--|--|---------------------------|
| 1                   | 1   | 1  | 1  | 1  | R                         |
| 2                   | 2   | 2  | 1  | 2  | Y                         |
| 3                   | 3   | 3  | 2  | 1  | R                         |
| 4                   | 4   | 4  | 2  | 2  | R                         |
| 5                   | 5   | 5  | 3  | 2  | R                         |
| 6                   | 6   | 6  | 3  | 1  | Y                         |
| 7                   | 7   | 7  | 4  | 2  | R                         |
| 8                   | 8   | 8  | 4  | 1  | R                         |
| 2 PED               | 9   | 9  | -  | -  | D                         |
| 4 PED               | 10  | 10   | -  | -  | D                         |
| 6 PED               | 11  | 11   | -  | -  | D                         |
| 8 PED               | 12  | 12   | -  | -  | D                         |
| O/L A               | 13  | 13   | 5  | 1  | R                         |
| O/L B               | 14  | 14   | 5  | 2  | R                         |
| O/L C               | 15  | 15   | 6  | 1  | R                         |
| O/L D               | 16  | 16   | 6  | 2  | R                         |

Provide flasher circuits and flash transfer relay outputs and inputs that are brought out to terminals which provide a convenient means of changing flash color and flash circuit at each load

switch position. Ensure that changing flash color of a given phase or overlap involves no more than moving three wires. Ensure that the selected phase or overlap flash color load switch output is easily movable to connect to the normally open flash transfer relay input assigned to the phase or overlap. Ensure that the common output of the flash transfer relay circuit assigned to the phase or overlap is easily movable to the selected field terminal (input) of the phase or overlap flash color. Ensure that the non-flashed load switch output is easily moved to provide power directly to the phase or overlap field terminal for that color.

In cabinets requiring a Type 1 detector rack, route to and terminate on a conveniently located terminal block on the back panel or elsewhere in the cabinet, the eight unused detector BIU Vehicle Call inputs. Tie the 8 unused detector BIU Detector Status inputs to the logic ground.

Provide detector racks and associated detector rack BIUs that are removable and replaceable from the cabinet either as a complete assembly or separately. Ensure that disconnection and reconnection of these units is through quick disconnect type connectors.

### **12.9. MATERIALS – TYPE 170 DETECTOR SENSOR UNITS**

Furnish detector sensor units that comply with Chapter 5 Section 1, “General Requirements,” and Chapter 5 Section 2, “Model 222 & 224 Loop Detector Sensor Unit Requirements,” of the CALTRANS “Transportation Electrical Equipment Specifications” dated March 12, 2009 with Erratum 1.

### **12.10. MATERIALS – NEMA TS-1 DETECTORS**

Furnish NEMA TS-1 single-channel or multi-channel detectors.

Provide multi-channel detectors that sequentially scan each of its channels. Ensure that the multi-channel detectors can turn a channel off and disable its operation from the front panel.

Provide channels with a minimum of eight sensitivity levels.

Ensure detector units meet the requirements of NEMA TS-1 Specifications except as follows:

- Class 2 vehicle output is maintained for a minimum of 4 minutes, and
- Class 3 vehicle output is maintained for a minimum of 30 minutes, maximum 120 minutes.

Where required, furnish detectors equipped with required timing features. Provide a delay that is settable in one-second increments (maximum) over the range of zero to thirty seconds. Provide an extend that is settable in 1/4 second increments (maximum) over the range of 0 to 15 seconds. Provide detectors that can set both delay and extend timing for the same channel. If both timings are set, ensure the delay operates first. After the delay condition has been satisfied, ensure that the extend timer operates normally and that it is not necessary to satisfy the delay timing for an actuation arriving during the extend portion.

Ensure detectors register a permanent call during tuning operations, as a result of a loop fault, and when power is removed. Ensure detectors completely self-tune within 10 seconds after application of power or restoration of interrupted power and within 10 seconds after correction of a loop fault.

Provide detectors that monitor the loop for fault conditions on each channel. Upon detection of a fault condition, even if the condition is subsequently corrected, ensure the detectors provide an indication of the occurrence and maintain the indication until a manual reset. The fault conditions are:

## Signals &amp; Intelligent Transportation Systems

- An open-circuited loop system;
- A short to ground; and
- A 25 percent reduction in inductance.

Ensure a two-channel detector operates normally with the same loop connected to both channels.

Provide lightning and surge protection that is incorporated into the design of the detector. Ensure that each channel operates properly when used with the loop detector surge protector.

In addition to NEMA TS-1 Specifications, ensure each channel is capable of tuning to and operating on any loop system inductance within the range of 50 to 2,000  $\mu$ h. Ensure that the channel will operate properly even on a loop system that has a single-point short to earth ground.

Provide detectors with a durably finished nonferrous housing. Ensure that the removal of the housing can be accomplished by using simple hand tools. Ensure each printed circuit board has a moisture resistant coating and that the components are readily accessible with the housing removed.

Provide a wiring harness with a minimum length of 6 feet for each detector. Ensure each wire is permanently labeled, numbered, or color-coded.

**12.11. MATERIALS – NEMA TS-2 DETECTOR CARDS AND RACKS**

Furnish NEMA TS-2 multi-channel detector cards and racks.

Provide cards that sequentially scan each of its channels. Provide channels with a minimum of eight sensitivity levels.

On a multi-channel detector, ensure that it is possible to turn a channel off and disable its operation from the front panel.

Ensure that detector units meet the requirements of NEMA TS-2 Specifications except as follows:

- Class 2 vehicle output is maintained for a minimum of 4 minutes, and
- Class 3 vehicle output is maintained for a minimum of 30 minutes, maximum 120 minutes.

Where required, furnish detector cards equipped with required timing features. Provide a delay that is settable in one second increments (maximum) over the range of zero to thirty seconds. Provide an extend that is settable in 1/4 second increments (maximum) over the range of 0 to 15 seconds. Provide cards that can set both delay and extend timing for the same channel. If both timings are set, ensure that the delay operates first. After the delay condition has been satisfied, ensure that the extend timer operates normally and that it is not necessary to satisfy the delay timing for an actuation arriving during the extend portion.

Ensure that two-channel detector cards operate normally with the same loop connected to both channels.

Provide lightning and surge protection that is incorporated into the design of the detector. Ensure that each channel operates properly when used with the loop detector surge protector.

In addition to NEMA TS-2 Specifications, ensure that each channel is capable of tuning to and operating on any loop system inductance within the range of 50 to 2,000  $\mu$ h. Ensure that the channel will operate properly even on a loop system that has a single-point short to earth ground.

**12.12. MATERIALS – TYPE 2070E CONTROLLERS**

Conform to CALTRANS *Transportation Electrical Equipment Specifications* (TEES) (dated March 12, 2009, plus Errata 1 dated January 21, 2010) except as required herein.

Furnish Model 2070E controllers. Ensure that removal of the CPU module from the controller will place the intersection into flash.

The Department will provide software at the beginning of the burning-in period. Contractor shall give 5 working days notice before needing software. Program software provided by the Department.

Provide Model 2070E controllers with the latest version of OS9 operating software and device drivers, composed of the unit chassis and at a minimum the following modules and assemblies:

- MODEL 2070-1E, CPU Module, Single Board, with 8Mb Datakey (blue in color)
- MODEL 2070-2A or approved MODEL 2070-2E, Field I/O Module (FI/O)
  - Note: Configure the Field I/O Module to disable both the External WDT Shunt/Toggle Switch and SP3 (SP3 active indicator is “off”)
- MODEL 2070-3B, Front Panel Module (FP), Display B (8x40)
- MODEL 2070-4, Power Supply Module, 10 AMP
- MODEL 2070-7A, Async Serial Com Module (9-pin RS-232)

Furnish one additional MODEL 2070-7A, Async Serial Com Module (9-pin RS-232) for all master controller locations.

For each master location and central control center, furnish a U.S. Robotics V.92 or approved equivalent auto-dial/auto-answer external modem to accomplish the interface to the Department-furnished microcomputers. Include all necessary hardware to ensure telecommunications.

**13. SPLICE CABINETS (TWISTED PAIR)**

**13.1. DESCRIPTION**

Furnish and install splice cabinets and all necessary hardware in accordance with the plans and specifications for the purpose of splicing and terminating twisted-pair cable.

**13.2. MATERIALS**

Furnish NEMA Type 4 splice cabinets of sufficient size to accommodate barrier-type termination strips to terminate all cable pairs under binding-type screws. Provide sufficient size so that the equipment installed will not occupy more than 60 percent of the total cabinet volume.

**13.3. CONSTRUCTION METHODS**

Install pole-mounted splice cabinets. Install cabinets approximately five feet from the ground line to the top of the cabinet. Locate cabinets so as not to obstruct sight distance of vehicles turning on red. Secure the cabinet to the pole using an approved installation method.

**13.4. MEASUREMENT AND PAYMENT**

Actual number of twisted-pair splice cabinets furnished, installed, and accepted.

Payment will be made under:

Twisted-pair Splice Cabinet .....Each

## **14. PORTABLE TRAFFIC SIGNAL SYSTEM**

### **14.1. DESCRIPTION**

Furnish, install, place in operation, repair, maintain, relocate, and remove portable traffic signal systems. Comply with the provisions of Section 1700 of the 2012 *Standard Specifications for Roads and Structures*.

### **14.2. MATERIALS**

Furnish material, equipment, and hardware under this section that is pre-approved on the ITS and Signals QPL.

Provide a complete portable traffic signal system that is totally mobile and capable of being relocated as traffic conditions demand. Design the system for operation both with and without an external power source. Furnish two signal control trailers with two vehicle signal heads per trailer and one operator unit for each portable traffic signal system. Furnish transmitters, generators, batteries, controls, back-up systems and all other components necessary to operate the system.

Ensure each system meets the physical display and operational requirements of conventional traffic signals as specified in PART IV of the *Manual on Uniform Traffic Control Devices (MUTCD)* and the *North Carolina Supplement to the MUTCD* in effect on the date of advertisement.

Used equipment will be acceptable if the equipment is in good working condition. Contractor retains ownership of the portable traffic signal systems.

Provide yellow 12-inch aluminum or polycarbonate vehicle signal heads with 10-inch tunnel visors, backplates and Light Emitting Diode (LED) modules. Provide aluminum signal heads and backplates listed on the Department's Qualified Products List (QPL) for traffic signal equipment. Provide polycarbonate signal heads and visors that comply with the provisions pertaining to Signal Heads within these *Project Special Provisions* with the following exceptions:

Fabricate signal head housings, end caps, and visors from virgin polycarbonate material. Provide U.V. stabilized polycarbonate plastic with a minimum thickness of  $0.1 \pm 0.01$  inches that is highway yellow (Federal Standard 595C, Color Chip 13538). Ensure the color is incorporated into the plastic material before molding the signal head housings and end caps. Ensure the plastic formulation provides the following physical properties in the assembly (tests may be performed on separately molded specimens):



| <b>Test</b>  | <b>Required</b>    | <b>Method</b> |
|--|--------------------|---------------|
| Specific Gravity                                   | 1.17 minimum       | ASTM D 792    |
| Vicat Softening Temperature, °F                    | 305-325            | ASTM D 1525   |
| Brittleness Temperature, °F                        | Below -200         | ASTM D 746    |
| Flammability                                       | Self-extinguishing | ASTM D 635    |
| Tensile Strength, yield, PSI                       | 8500 minimum       | ASTM D 638    |
| Elongation at yield, %                             | 5.5-8.5            | ASTM D 638    |
| Shear, strength, yield, PSI                        | 5500 minimum       | ASTM D 732    |
| Izod impact strength, ft-lb/in [notched, 1/8 inch] | 15 minimum         | ASTM D 256    |
| Fatigue strength, PSI at 2.5 mm cycles             | 950 minimum        | ASTM D 671    |

To minimize signal head movement due to wind, mount top and bottom of signal heads to the signal head supports.

Provide 120V AC powered LED modules listed on the QPL, or provide 12V DC powered LED modules that meet the *ITE VTCSH Part 2: Light Emitting Diode (LED) Vehicle Signal Modules (Interim Purchase Specification)* with the exception of paragraphs 5.2, 5.3, 5.7, and testing associated with 120V AC. Ensure DC powered LED modules operate with input power between 9V DC and 15V DC.

Provide trailers that have durable paint in highway orange, Federal Standard 595C Color Chip ID # 12473 with a minimum paint thickness of 2.5 mils.

Provide trailers with a 12-volt trailer lighting system complying with *Federal Motor Carrier Safety Regulations 393*, safety chains, and a 2-inch ball hitch. When provided, locate generators, fuel tanks, batteries and electronic controls in protective housings that are provided with locks to restrict access.

Design the trailer assembly and signal supports to withstand an 80 MPH wind load with the signal supports raised in the operating position. Provide independent certification from a registered Professional Engineer that the assembly meets this 80 MPH wind load requirement. Provide a reliable hydraulic, electric or manual means for raising and lowering the signal support members. Provide screw-type stabilizing and leveling devices with a self-leveling foot to support the unit in the operating position on slopes 1V:3H or flatter when detached from the transporting vehicle.

During manual operation, ensure the system provides a means of informing the operator of signal indications, such as a light on the back of each signal head that illuminates when the signal displays a red indication.

Design the portable traffic signal system to perform without interruption during the time it is in operation.

Where a traffic actuated system is required, provide a system control unit that is capable of pre-timed operation, traffic actuated operation, a variable green time interval dependent upon vehicle actuations, and programmable yellow clearance and red clearance intervals. Furnish all sensors to

monitor vehicle demands for vehicle actuation per the Project Special Provisions and Section 1098 of the Standard Specifications.

Design the systems to be fail-safe. Ensure the system monitors the following conditions: lack of green, yellow, and red signal indication voltage, total loss of indication on any approach, presence of multiple signal indications on any approach, conflicting green/yellow signal indications, and low power condition. In the event any of these conditions are detected, immediately begin flashing operation of red indications in all directions.

Provide either hard-wired, microwave, or radio controlled type communications for pre-timed and traffic actuated portable traffic signal systems. In the event a loss of communication is detected, immediately begin flashing operation of red indications in all directions.

Ensure systems that use wireless communication links continuously monitor and verify proper transmission and reception of data used to monitor and control each signal head. Ensure ambient mobile or other radio transmissions or adverse weather conditions do not affect the system. Encode signal transmissions digitally to protect radio transmissions from interference. Do not violate FCC regulations and ensure radio frequencies are appropriate for portable signal equipment applications.

Upon detecting a malfunction, ensure all signals go to a flashing red condition and the operator is notified by a reliable means approved by the Engineer. Provide a battery back-up system for generator and direct current powered signal systems to power the warning means and "flashing red" condition. Provide a back-up system with a 72-hour minimum reserve.

Ensure the system meets the Environmental Standards for traffic signals in accordance with NEMA TS-1, Section 2.

### **14.3. CONSTRUCTION METHODS**

Do not use portable traffic signal systems in a work area with intersecting streets or driveways, unless directed by the Engineer.

Do not install portable traffic signal within 300 feet of at-grade railroad crossing.

During automatic operation, ensure the motorist has an unobstructed view of opposing traffic.

Ensure the distance between signal units does not exceed 500 feet unless otherwise shown on the plans or directed by the Engineer. If modification to the distance between signal units is required after the units are positioned, relocate the signals or the system and make the necessary timing revisions only as directed by the Engineer.

Submit a traffic signal timing plan to the Engineer for approval a minimum of two weeks prior to installation. Include the following items in the plan: distance between stop bars, speed limit to be posted during operation, each approach grade, recommended yellow change interval, recommended red clearance interval, recommended minimum and maximum green intervals. Make timing changes to approved signal timing plan only as authorized by the Engineer. Keep a written record of all timing changes.

Allow only trained operators to set up and operate the system. Provide an experienced operator at all times for each portable traffic signal system during periods of manual operation. Do not violate yellow change and red clearance intervals during periods of manual operation. During manual operation, ensure the operator has an unobstructed view of the motorists and all signal head units. Locate the operator as close to the center of the operation as possible.

Perform all maintenance operations required by the system manufacturer including periodic cleaning of the systems. Ensure properly skilled and trained maintenance personnel are available to maintain the system in good working order and to perform all emergency and preventive maintenance as recommended by the system manufacturer.

**TIP Number**

**County Name**

Signals & Intelligent Transportation Systems

Furnish the Engineer with the name, office telephone number, cellular (mobile) telephone number, and pager number of the supervisory employee who will be responsible for maintenance and repair of equipment during all hours.

For all failures, malfunctions, or damage to this equipment, begin necessary repairs within four hours of notification. Complete repairs within eight hours of notification. Comply with Section 150 for maintenance of traffic flow. The inability to contact the supervisory employee or prearranged alternate will not extend repair time requirements.

In the event that the system becomes inoperative, be prepared at all times to revert to flagging operations or suspend all construction activities requiring the use of the portable traffic signal system until the system is restored to proper operation. Implement flagging operations as shown on 2012 Roadway Standard Drawing No. 1101.02 Sheet 1 (Closure of one lane of a Two-lane, Two-way Highway).

When not in operation, remove signal heads from the view of traffic or cover signal heads with burlap bags or bags made of non-ripping material specifically designed for covering signal heads. Do not use trash bags of any type. Remove, cover, fold, or turn all inappropriate signs so that they are not readable by oncoming traffic.

**14.4. MEASUREMENT AND PAYMENT**

Actual number of portable traffic signal systems furnished, installed, operated, removed, and accepted.

No measurement will be made for operation, relocation, maintenance, removal of each system, or use of flaggers during repair periods as these will be considered incidental to furnishing, installing, and operating the portable traffic signal systems.

No measurement will be made for signal controller, communication cable, messenger cable, wireless communication, inductive loop sawcut, loop emulator detection system, machine vision detection system, microwave detection system, detector channel/unit, detector lead-in cable, trenching, vehicle signal heads, signal head support assemblies, signal cable, and traffic signal software as these will be considered incidental to furnishing, installing, and operating the portable traffic signal systems.

Payment will be made under:

|  |      |
|--|------|
| Portable Traffic Signal System (actuated).....   | Each |
| Portable Traffic Signal System (pre-timed) ..... | Each |

**15. GPS UNIT**

**15.1. DESCRIPTION**

Furnish and install a GPS unit in the traffic signal cabinet for time synchronization in accordance with the plans and specifications. Comply with the provisions of Section 1700 of the 2012 Standard Specifications for Roads and Structures.

**15.2. MATERIALS**

Provide Trimble Acutime Gold GPS Smart Antenna, or an approved equivalent, for time synchronization that is compatible with Oasis 2070 controller software.

**15.3. CONSTRUCTION METHODS**

Mount GPS antenna on pole adjacent to cabinet at a minimum height of 10' insuring that the antenna can acquire enough satellites to be accurate. Use 3/4" rigid metallic conduit with appropriate

fittings for mounting the antenna and running the lead-in cable. Provide GPS antenna lead-in cable that is not more than 50' in length. Provide a drip loop in the cable before it enters the conduit. Insure the cable entry point into the conduit is waterproof. If a pole is not within 30' of the cabinet, the GPS antenna may be mounted to the top of the cabinet, while insuring that the connection point into the cabinet is waterproof.

**15.4. METHOD OF MEASUREMENT**

Actual number of GPS units furnished, installed, and accepted.

No measurement will be made for interface cables and connectors, as these are considered incidental to furnishing and installing the GPS unit assemblies.

**15.5. BASIS OF PAYMENT**

The quantity of GPS units, measured as provided above, will be paid for at the contract unit price each for "GPS Unit."

Payment will be made under:

GPS Unit.....Each

**16. PUSH BUTTON INTEGRATED ACCESSIBLE PEDESTRIAN SIGNAL (APS)**

**16.1. DESCRIPTION**

Furnish and install push button integrated accessible pedestrian signals that include pedestrian push button, push button locator tone, raised tactile arrow, audio and vibro-tactile walk indications, automatic volume adjustment, pedestrian information sign, and all necessary hardware. Furnish the R10-3e with appropriate arrow direction for the pedestrian information sign.

**16.2. MATERIALS**

Furnish material, equipment, and hardware under this section that is pre-approved on the ITS and Signals QPL.

Provide the accessible pedestrian signals with a 2-inch diameter pedestrian push button that contains a tactile arrow whose direction can be easily adjusted in the field. Ensure each push button actuates a sturdy, momentary, normally-open switch with a minimum rating of 20 million actuations. Include on the button, a raised tactile arrow having a high visual contrast with the remainder of the button face. Ensure the housing is weather-tight and fabricated from aluminum. Ensure the housing is suitable for mounting on wood and metal poles. Paint surfaces of the pedestrian push button housing in highway yellow, unless otherwise specified, with an electrostatically-applied, fused-polyester paint method. Ensure the thickness of the paint is a minimum of 2.5 mils. Provide the pedestrian information sign that is integral to the housing.

Ensure the accessible pedestrian signals can provide tones, sounds, and speech messages that are synchronized at an intersection. Provide a means for adjusting the base sound level for the tones, sounds, and speech messages. Ensure the tones, sounds, and speech messages will adjust automatically to the ambient noise level up to a maximum of 100 dBA. Provide the custom speech messages in both English and Spanish languages. Ensure you can program the accessible pedestrian signal by a means not readily accessible by unauthorized persons.

Ensure each push button provides a standard locator tone that is deactivated when the traffic signal is operating in the flash mode. Provide a user-programmable audible beaconing feature that is initiated by an extended push button press of one second or more. Ensure the audible beaconing feature increases the volume of the push button locator tone during the pedestrian change interval of the called pedestrian phase and operates in one of the following ways:

- A. The louder audible walk indication and louder locator tone comes from the far end of the crosswalk, as pedestrians cross the street,
- B. The louder locator tone comes from both ends of the crosswalk, or
- C. The louder locator tone comes from an additional speaker that is aimed at the center of the crosswalk and that is mounted on a pedestrian signal head.

Provide confirmation of the push button activation by an LED pilot light. Ensure the pilot light remains illuminated until the pedestrian's green or WALKING PERSON (symbolizing WALK) signal indication is displayed. Ensure each press of the pushbutton initiates a "wait" speech message during all intervals except the Walk interval.

Ensure you can select a percussive tone and custom speech message to sound during the "Walk" interval. Provide a push button that vibrates during the "Walk" interval. Ensure the "Walk" indications have the same duration as the illuminated pedestrian signals except when the signal is programmed to rest in the walk interval. Ensure the "Walk" indications are deactivated when the traffic control signal is operating in a flashing mode. When audible "Walk" indications are selected as a percussive tone, ensure the tone repeats at 8 to 10 ticks per second and consists of multiple frequencies with a dominant component at 880 Hz.

Ensure the accessible pedestrian signals are weatherproof and suitable for operation in wet locations. Ensure proper operation over a temperature range of -30°F (-34°C) to 165°F (+74°C). Ensure all circuit boards have a moisture resistant coating. Ensure the equipment interfaces and operates properly in a Type-170E cabinet.

### **16.3. CONSTRUCTION METHODS**

Comply with the requirements of Section 1705 of the *Standard Specifications*. Install in accordance with the manufacturer's recommendations.

Mount push button integrated accessible pedestrian signals in a tamperproof manner on wood and metal poles, signal pedestals, or pushbutton posts as indicated in the signal plans.

Install each pushbutton so that the tactile arrow is pointed in the direction of travel and is aligned parallel to the direction of travel on the associated crosswalk.

Ensure pushbuttons are separated by a distance of at least 10 feet such that they clearly indicate which crosswalk has the WALK indication. Where there are constraints on a particular corner that make it impractical to provide the 10 feet of separation between the two pushbuttons, the pushbuttons may be placed closer together or on the same pole, with approval by the Engineer. If two pushbuttons are placed on the same pole or with less than 10 feet separation, provide a speech walk message for the WALK indication and a speech pushbutton information message.

Adjust the intensity of the pushbutton locator tones so they are audible 6 feet to 12 feet from the pushbutton, or to the building line, whichever is less. Ensure the pushbutton locator tones are no

**TIP Number**

**County Name**

Signals & Intelligent Transportation Systems

more than 5 dBA louder than ambient sound. Configure audible “Walk” indication to be audible at the nearest end of the associated crosswalk.

If speech messages are used, have each recorded custom speech message approved by the Engineer in advance.

**16.4. MEASUREMENT AND PAYMENT**

Actual number of push button integrated accessible pedestrian signal detector stations furnished, installed, and accepted.

Actual number of central control units for APS detector stations furnished, installed, and accepted.

Actual number of push button posts furnished, installed, and accepted.

No measurement will be made of cables or hardware, as these will be considered incidental to furnishing and installing push button integrated accessible pedestrian signals.

|   |      |
|---|------|
| APS Detector Stations .....                           | Each |
| Central Control Units For APS Detector Stations ..... | Each |
| Push button Posts .....                               | Each |

**17. WIRELESS MAGNETIC SENSOR VEHICLE DETECTION SYSTEM**

**17.1. DESCRIPTION**

Furnish a vehicle detection system that uses battery-powered magnetic field sensors for pavement installation that communicate traffic detection data by wireless communication to a transceiver for a local traffic signal cabinet. Ensure each sensor responds to the change in the earth’s local magnetic field resulting from the presence and passage of a vehicle. Ensure the system contains sensor(s), transceiver(s), and any other device(s) to provide detection data to a traffic signal controller.

**17.2. MATERIALS**

Furnish material, equipment, and hardware under this section that is pre-approved on the ITS and Signals QPL.

Provide magnetic sensors to detect vehicle traffic such as cars, trucks, and motorcycles. Ensure each sensor is sized for an installation into a 4-inch diameter by 3-inch deep hole. Ensure the sensor provides vehicle traffic data for volume and occupancy. Ensure the sensor holds a detection call when a vehicle is stopped in its detection field. Provide a sensor to simulate a detection zone of a 6’ x 6’ inductive loop. Provide a combination of sensors to simulate a detection zone of a 6’ x 40’ quadrupole inductive loop and a 6’ x 60’ quadrupole inductive loop. Ensure the sensors operate as specified by the intersection design plans.

Provide two-way wireless communication between the sensors and the transceiver devices. Ensure no disruption to the wireless communication when the transceiver devices are located on the side of the road surface. Ensure that the sensors can communicate with the transceiver devices for a

minimum distance of 100 feet. Ensure all wireless communications within the system operate in an unlicensed frequency band and avoid interference with other devices operating in the unlicensed frequency band. Provide at least 16 frequency channels that are user-configurable.

Provide each sensor to transmit its detection data within 150 ms of a detected event. Ensure the sensor samples the earth's magnetic field at a rate of 128 Hz or faster. Ensure that each sensor transmits a unique identifying code. Ensure that each sensor automatically recalibrates its threshold values in response to changes in the ambient magnetic field based on user-programmed criteria.

Furnish each sensor that is manufactured as a single housing module that conforms to NEMA Type 6P enclosure. Ensure that the components of the sensor are fully encapsulated within the housing to prevent moisture from degrading the components. Ensure the sensor operates at temperatures from -37 degrees F to 176 degrees F. Provide battery-power with an average life expectancy of 10 years when the sensor is operating under normal traffic conditions.

Provide a clear injection molded clamshell style case made of polypropylene for protecting the sensor in the roadway. Ensure case protects the sensor from sealant material. Ensure the case holds the sensor in place and is form-fitting to ensure cured sealant does not collapse when exposed to traffic loads.

Furnish the transceiver to provide detection data to the traffic signal cabinet and ensure the traffic signal controller receives each sensor detection call. Ensure the traffic signal controller receives both presence mode and pulse mode detection calls.

Provide indications inside the traffic signal cabinet to display each channel detection status and fault condition. Provide a switch inside the traffic signal cabinet to select presence mode and pulse mode for each channel. Provide user-selectable sensitivity levels for vehicle detection. Furnish equipment to operate in Type 332 and 336S traffic signal cabinets.

Provide software for installation and use on personal computers to upload and download configuration data to each sensor. Ensure application software is compatible with Windows 2000 and Windows XP operating systems. Ensure software does not require administrative permissions to load and operate. Ensure the software can retrieve and store detection data from the sensors. Ensure the software on the personal computer transmits data from the personal computer to each sensor through the transceiver by wireless communication. Also, provide any update to the firmware in each sensor by wireless communication. Provide a license to the Department to allow the duplication of the personal computer software as needed to design, install and maintain these systems.

### **17.3. CONSTRUCTION METHODS**

Install the wireless magnetic sensor vehicle detector system in accordance with the manufacturer's recommendations. Enclose the wireless magnetic sensor in a molded clamshell style case before installation into the roadway. When installing each sensor into the hole, ensure epoxy sufficiently covers the sensor in the road surface.

Arrange and conduct site surveys with the system manufacturer's representative and Department personnel to determine proper sensor and transceiver selection and placement. Provide the Department at least 3 working days notice before conducting site surveys. The Engineer will approve final locations of sensors, transceivers and any necessary repeaters.

Install the transceiver in such a manner that avoids conflicts with other utilities and as specified in the manufacturer’s recommendations. Secure the transceiver mounting hardware to the pole and route the cabling such that no strain is placed on connectors.

Before beginning work at locations that require a wireless magnetic sensor vehicle detector system, furnish system software. Upon activation of the system, provide detector configuration files.

Place system into operation. Configure wireless magnetic sensor vehicle detector system to achieve required detection in designated areas. Have a certified manufacturer’s representative on site to supervise and assist with installation, set up, and testing of the system.

Install the necessary processing and communications equipment in the signal controller cabinet. Make all necessary modifications to install equipment in cabinet. Ensure the traffic signal controller receives each sensor detection call.

Place a copy of all manufacturer equipment specifications and instruction and maintenance manuals in the equipment cabinet.

Provide at least 4 hours of training on the set up, operation, troubleshooting, and maintenance of the wireless magnetic sensor vehicle detector system to a maximum of ten Department personnel. Arrange for training to be conducted by the manufacturer’s representative at an approved site within the Division responsible for administration of the project. Thirty days before conducting training submit a detailed course curriculum, draft manuals and materials, and resumes. Obtain approval of the submittal before conducting the training. At least one week before beginning training, provide three sets of complete documentation necessary to maintain and operate the system. Do not perform training until installation of the wireless magnetic sensor vehicle detector system is complete.

**17.4. MEASUREMENT AND PAYMENT**

Actual number of wireless magnetic sensor vehicle detector systems furnished, installed, and accepted.

No measurement will be made of cables or hardware, as these will be considered incidental to furnishing and installing wireless magnetic sensor vehicle detector system.

Payment will be made under:

Wireless Magnetic Sensor Vehicle Detector System.....Each

**18. TEMPORARY STATIONARY TRAFFIC SIGNAL SYSTEM**

**18.1. DESCRIPTION**

Furnish, install, place in operation, repair, maintain, reposition, and remove the temporary stationary traffic signal system. Comply with the provisions of Section 1700 of the 2012 Standard Specifications for Roads and Structures and the generic Project Special Provisions for Signals and Intelligent Transportation Systems located at:

<http://www.ncdot.org/doh/preconstruct/traffic/ITSS/>

**18.2. MATERIALS**

Provide a complete temporary traffic signal system including but not limited to 12-inch vehicle signal heads, signal cable, messenger cable, wood poles, guy assemblies, inductive detection loops,



## Signals &amp; Intelligent Transportation Systems

microwave vehicle detectors, lead-in cable, trenching, riser assemblies, required signs, detector units, 2070 controller with 336 pole mounted cabinet, and appropriate pavement markings.

All traffic signal equipment must be in compliance with the plans provided by NCDOT (**plans will be provided upon request from the contractor**), the project special provisions, and the 2012 Standard Specifications for Roads and Structures.

### 18.3. CONSTRUCTION METHODS

NCDOT will provide the temporary stationary traffic signal plans **30 days** after **written request** is submitted to the Engineer. Plan requests shall consist of the following information: a drawing showing the exact location of the stopbars (include Stations), speed limit posted during operation, percent grade on each approach, times and duration of operation.

Ensure that the signal meets the physical display and operational requirements of conventional traffic signals as specified in PART IV of the *Manual on Uniform Traffic Control Devices (MUTCD)* and the *North Carolina Supplement to the MUTCD* in effect on the date of advertisement.

Perform all maintenance operations required by the manufacturer. Have properly skilled and trained maintenance personnel available to maintain the system in good working order and to perform all emergency and preventive maintenance as recommended by the equipment manufacturer.

Furnish the Engineer with the name, office telephone number, cellular (mobile) telephone number, and pager number of the supervisory employee who will be responsible for maintenance and repair of equipment during all hours.

In the event that the signal becomes inoperative, be prepared at all times to revert to a flagging operation or suspend all construction activities requiring the use of the temporary stationary traffic signal system until the signal is restored to proper operation.

Remove signals within two weeks of completion of work requiring the use of temporary stationary traffic signal system.

### 18.4. MEASUREMENT AND PAYMENT

Actual number of **days** that each Temporary Stationary Traffic Signal System is operated.

No measurement will be made for operation, relocation, maintenance, removal of each signal system, or use of flaggers during repair periods as these will be considered incidental to furnishing, installing, and operating the Temporary Traffic Signal System.

Any Temporary Stationary Traffic Signal System used for less than one hour will be considered incidental to the operation that required the use of such signal.

No measurement will be made for signal controller, communication cable, messenger cable, wireless communication, inductive loop sawcut, loop emulator detection system, machine vision detection system, microwave detection system, detector channel/unit, detector lead-in cable, trenching, vehicle signal heads, signal head support assemblies, signal cable, and traffic signal software as these will be considered incidental to furnishing, installing, and operating the Temporary Traffic Signal System.

Refer to “Temporary Traffic Signal System Alternates” Special Provision for payment.

## **19. PROTECTIVE POWDER COATING FOR METAL POLES WITH MAST ARMS AND PEDESTRIAN SIGNAL PEDESTALS**

### **19.1. DESCRIPTION**

Provide protective (INSERT COLOR) powder coating for all mast arms with metal poles and all pedestrian signal pedestals including all necessary hardware for the signalized intersection in accordance with the plans and specifications.

### **19.2. MATERIALS**

Furnish metal poles with mast arms and pedestrian signal pedestals that provide galvanic protection along with a tough and durable powder application.

Furnish pole caps that have a (INSERT COLOR) low gloss powder finish applied over a hot-dipped galvanized surface. Comply with the applicable provisions of Section 442-10 of the 2012 Standard Specifications for Roads and Structures

**The color selected for (INSERT COLOR) protective coating for metal poles with mast arms and pedestrian signal pedestals must be approved by the (INSERT NAME OF APPROVING PARTY) prior to fabrication.**

### **19.3. POWDER COATING SHOP APPROVAL**

The powder coating shop shall be approved prior to the application of any powder coating process. All requests, procedures and documents shall be submitted electronically to:

- Mr. Brian Hunter, P.E., Chemical Testing Engineer
- bhunter@ncdot.gov

D) Submit a quality control procedure that the company has established to ensure a quality and durable coating. The quality control procedure shall contain at a minimum the following:

- Qualified / Certified personnel to manage the QC Program and to conduct Quality Control tests
- Qualified / certified coaters
- Source and type of powder
- How the powder will be stored
- Powder application facility (heated or unheated)
- Surface pre-treatment
- Surface preparation including profile
- Application methods
- Curing conditions (conventional or infrared)
- Curing Temperature
- Adhesion & Holiday Detection
- Repair Procedure
- Storage and protection of coated items

- Shipping and handling (packing, protection, and wrapping)
- E) Submit a powder certification from the manufacturer
- F) The following shall be submitted to the Chemical Testing Engineer a minimum of four weeks prior to coating application.
6. Two test panels of ASTM A36 steel, ¼ or greater in thickness measuring 8 inches by 11 inches using the proposed color of the final coat; a powder coated over galvanized test panel and a powder coated over un-galvanized test panel.
  7. In addition two (2) samples shall be made of the same or comparable material and thickness as production pieces. Production piece replicas shall not be greater than twelve (12") in length or width nor weigh greater than 50 lbs.
  8. All test panels shall be accompanied with inspection reports and records according to NCDOT *Standard Specifications* 2012, Section 442, Section 1072, Section 1076, and Section 1080.
  9. Acceptance of the panels is determined by meeting the requirements of ASTM D-4541 of 800 psi for both galvanized and un-galvanized and production piece test panels.
  10. All panels shall be sent to :

Materials and Tests Unit

1801 Blue Ridge Road

Raleigh, NC 27607

Attn: Chemical Testing Engineer

#### **19.4. CONSTRUCTION METHODS**

##### **A. Galvanizing**

Galvanizing of steel products shall be performed in accordance with Section 1076 of the North Carolina Department of Transportation Standard Specifications for Roads and Structures. The fabricator or designated representative(s) that is supplying the components to be galvanized shall communicate with the galvanizer to indicate that the galvanized pieces will be powder coated to avoid water or chromate quenching.

##### **B. Surface Preparation**

Comply with manufacturers recommended surface coating specifications, Steel Structure Painting Council (SSPC) specifications and applicable articles of Section 442 (Painting Steel Structures) of the NCDOT Standard Specifications. Ensure that surface preparations and treatments are performed and meet the requirements of the above referenced specifications.

Some pole components, specifically steel plates ¾ inches or more in thickness may need blast cleaning prior to structure assembly to remove impurities and non-metallic foreign materials. Mechanically remove all weld flux after structure is assembled

Degrease and prepare structure for zinc coating after assembly using full immersion baths and pickling processes in heat controlled caustic and acid solutions. Rinse and clean structure to remove caustic or acid solutions by immersion in a circulating fresh water bath. Immerse structure in a heat controlled concentrated zinc ammonium chloride flux solution and air dry as a final prep before hot-dip galvanization.

In no case shall the surface preparation be less than that specified by the powder manufacturer's recommendations. All components to be coated shall be prepared in accordance with SSPC SP-2

**TIP Number****County Name**

Signals & Intelligent Transportation Systems

(Hand Tool Cleaning) and/or SSPC SP-3 (Power Tool Cleaning). All drainage spikes, high spots, protrusions or other surface defects shall be removed using hand or power tools. Do not remove the galvanization below the limits set forth in AASHTO M111.

Remove grease, oils, moisture, scale, rust or any other foreign matter prior to powder coating to ensure ideal adhesion and coating performance. Prepare and coat the galvanized surface as soon as possible after the galvanization process.

**C. Powder Coating Application and Curing**

Prepare galvanized finish for powder coating by brush blasting in accordance with SSPC-SP7. Ensure all threaded components of the structure are protected from damage during blasting process.

Use thermosetting powder resin that meets 5A or 5B classifications of ASTM D3359. Apply powder coating electrostatically. Follow manufacturer's recommended preheating requirements. Ensure the top coat finish is applied uniformly to all surfaces with a dry film thickness of between 3.0 to 5.0 mils. Cure the top coat by heating the structure to manufacturer recommended temperatures at the duration required to ensure complete and uniform bond is

**D. Quality Control:**

The applicator shall provide all test reports, provide documentation and inspect all coated material as outlined in NCDOT *Standard Specifications* 2012, Section 442, Section 1072, Section 1076, and Section 1080. The quality control inspector shall be separate from the production functions.

**E. Storage, Shipping, and Handling**

All powder coated material shall be stored inside unless there is no facility present or at the Engineers approval.

All shipping and handling either from powder facility to project site and or storage site to area(s) to construction location shall be protected from incurring damage to product. In no case shall the product be stored directly on the ground, in areas where pooling water may occur; the Engineer determines the effectiveness of all storage, shipping and handling methods.

**F. Repair of Powder Coated Material**

It is the Department's resolve that both the shop and Contractor providing these products use the utmost of care in handling, packaging, shipping and installing these products. The process in which this coating was applied cannot be duplicated in a field environment, thus any repairs are considered detrimental to the longevity of the coating system The Department has specified the following for repairing powder coating.

All damage to the coating which occur or is discovered in the shop shall be repaired by the original method of application as outlined in the coating facilities repair procedure. All repair areas shall meet the original requirements for adhesion as stated in this Project Special Provision.

All damaged discovered upon delivery to the project site prior to unloading shall be recorded by pictures and documentation by the Engineer or their authorized representative and shall be reported to applicator. The Engineer has the authority to accept or reject the material as outlined in the NCDOT *Standard Specifications*.

Damaged coatings which occur during storage, transporting, handling and or installation, the Contractor shall submit to the Engineer a repair procedure. The Contractor shall utilize a liquid paint approved by the Department, compatible with the powder applied product. All repair areas shall demonstrate an adhesion rating of 400 psi in accordance with ASTM D-4541. Acceptance on the final finish shall be determined by the Engineer.

**19.5. MEASUREMENT AND PAYMENT**

Actual number of protective (INSERT COLOR)coatings for Single mast arm assemblies furnished, installed, and accepted.

Actual number of protective (INSERT COLOR)coatings for Dual mast arm assemblies furnished, installed, and accepted.

Actual number of protective (INSERT COLOR)coatings for pedestrian signal pedestals and bases furnished, installed, and accepted.

Payment will be made under:

Protective (INSERT COLOR)Coating for Single mast arm assembly ..... Each

Protective (INSERT COLOR)Coating for Dual mast arm assembly..... Each

Protective (INSERT COLOR)Coating for Pedestrian Signal Pedestal..... Each