

STATE OF NORTH CAROLINA
DEPARTMENT OF TRANSPORTATION
HIGHWAY DIVISION 6

PROPOSAL

SMALL BUSINESS ENTERPRISE

NON-EXCLUSIVE CONTRACT ANNUAL RENEWABLE - 3 YEARS

DATE & TIME OF BID
OPENING: JANUARY 18, 2017 AT 10:00 AM

CONTRACT NO.: D6D2.SBE.001

WBS ELEMENT NO.: 6.102611, 6.202611, 6.202611, 6.202621, 6.102631, 6.104311,
6.204311, 6.204321 & 6.104331

FEDERAL AID NO.: STATE FUNDED

COUNTY: CUMBERLAND & HARNETT

ROUTE NO.: VARIOUS ROADS

TYPE OF WORK: MISCELLANEOUS CONCRETE CONSTRUCTION

NOTICE:

ALL BIDDERS SHALL COMPLY WITH ALL APPLICABLE LAWS REGULATING THE PRACTICE OF GENERAL CONTRACTING AS CONTAINED IN CHAPTER 87 OF THE GENERAL STATUTES OF NORTH CAROLINA WHICH REQUIRES THE BIDDER TO BE LICENSED BY THE N.C. LICENSING BOARD FOR CONTRACTORS WHEN BIDDING ON ANY NON-FEDERAL AID PROJECT WHERE THE BID IS \$30,000 OR MORE, EXCEPT FOR CERTAIN SPECIALTY WORK AS DETERMINED BY THE LICENSING BOARD. BIDDERS SHALL ALSO COMPLY WITH ALL OTHER APPLICABLE LAWS REGULATING THE PRACTICES OF ELECTRICAL, PLUMBING, HEATING AND AIR CONDITIONING AND REFRIGERATION CONTRACTING AS CONTAINED IN CHAPTER 87 OF THE GENERAL STATUTES OF NORTH CAROLINA. NOTWITHSTANDING THESE LIMITATIONS ON BIDDING, THE BIDDER WHO IS AWARDED ANY FEDERAL - AID FUNDED PROJECT SHALL COMPLY WITH CHAPTER 87 OF THE GENERAL STATUTES OF NORTH CAROLINA FOR LICENSING REQUIREMENTS WITHIN 60 CALENDAR DAYS OF BID OPENING.

THIS IS A ROADWAY PROJECT.

BID BONDS **ARE NOT** REQUIRED.

NAME OF BIDDER

ADDRESS OF BIDDER

PROPOSAL**NC DEPARTMENT OF TRANSPORTATION****RALEIGH, NORTH CAROLINA**

The Bidder has carefully examined the location of the proposed work; has carefully examined the plans and specifications, which are acknowledged to be part of the proposal, the special provisions, the proposal, the form of contract, and the forms of contract payment bond and contract performance bond; and thoroughly understands the stipulations, requirements and provisions. The undersigned bidder agrees to bound upon his execution of the bid and subsequent award to him by the Department of Transportation in accordance with this proposal to provide the necessary contract payment bond and contract performance bond within fourteen days after the written notice of award is received by him. The undersigned Bidder further agrees to provide all necessary machinery, tools, labor, and other means of construction; and to do all the work and to furnish all materials, except as otherwise noted, necessary to perform and complete the said contract in accordance with *the 2012 Standard Specifications for Roads and Structures* by the dates(s) specified in the Project Special Provisions and in accordance with the requirements of the Engineer, and at the unit or lump sum prices, as the case may be, for the various items given on the sheets contained herein.

The Bidder shall provide and furnish all the materials, machinery, implements, appliances and tools, and perform the work and required labor to construct and complete this contract, for the unit or lump sum prices, as the case may be, bid by the Bidder in his bid and according to the proposal, plans, and specifications prepared by said Department, which proposal, plans, and specifications show the details covering this project, and hereby become a part of this contract.

The published volume entitled *North Carolina Department of Transportation, Raleigh, Standard Specifications for Roads and Structures, January 2012* with all amendments and supplements thereto, is by reference incorporated into and made a part of this contract; that, except as herein modified, all the construction and work included in this contract is to be done in accordance with the specifications contained in said volume, and amendments and supplements thereto, under the direction of the Engineer.

If the proposal is accepted and the award is made, the contract is valid only when signed either by the Contract Officer or such other person as may be designated by the Secretary to sign for the Department of Transportation. The conditions and provisions herein cannot be changed except over the signature of the said Contract Officer or Division Engineer.

The quantities shown in the itemized proposal for the project are considered to be approximate only and are given as the basis for comparison of bids. The Department of Transportation may increase or decrease the quantity of any item or portion of the work as may be deemed necessary or expedient.

An increase or decrease in the quantity of an item will not be regarded as sufficient ground for an increase or decrease in the unit prices, nor in the time allowed for the completion of the work, except as provided for the contract.

TABLE OF CONTENTS

**COVER SHEET
PROPOSAL SHEET**

INSTRUCTIONS TO BIDDERS4
GENERAL:5
SMALL BUSINESS ENTERPRISE PROGRAM:5
AUTHORITY OF THE ENGINEER:5
CONTRACT TIME AND LIQUIDATED DAMAGES:5
CONTRACT PERIOD:6
PROSECUTION AND PROGRESS:6
NON-EXCLUSIVE CONTRACT:6
INTERMEDIATE CONTRACT TIME AND LIQUIDATED DAMAGES:6
INSPECTION:8
SUBSURFACE INFORMATION:8
UTILITY CONFLICTS:8
LOCATING EXISTING UNDERGROUND UTILITIES:8
DIVISION SIX TRAFFIC SERVICES CONTACT:8
DOMESTIC STEEL:8
OUTSOURCING OUTSIDE THE USA:8
IRAN DIVESTMENT ACT:9
GIFTS FROM VENDORS AND CONTRACTORS:9
LIABILITY INSURANCE:9
EMPLOYMENT:9
STATE HIGHWAY ADMINISTRATOR TITLE CHANGE:10
SUBLETTING OF CONTRACT:10
SUPERVISION BY CONTRACTOR:10
EQUIPMENT:10
CONFORMITY WITH THE CONTRACT:10
PAYMENT AND RETAINAGE:11
FLAGGERS:11
ROADWAY12
AVAILABILITY OF FUNDS – TERMINATION OF CONTRACTS:30
ERRATA:30
PLANT AND PEST QUARANTINES:31
MINIMUM WAGES:32
AWARD OF CONTRACT:32
ON-THE-JOB TRAINING:35
NAME CHANGE FOR NCDENR:37
EXECUTION OF BID.....38
EXECUTION OF CONTRACT.....47

INSTRUCTIONS TO BIDDERS

**PLEASE READ ALL INSTRUCTIONS CAREFULLY
BEFORE PREPARING AND SUBMITTING YOUR BID.**

All bids shall be prepared and submitted in accordance with the following requirements. Failure to comply with any requirement may cause the bid to be considered irregular and may be grounds for rejection of the bid.

TRADITIONAL PAPER BIDS:

1. Download the entire proposal from the **Connect NCDOT website** and **return the entire proposal with your bid.**
2. All entries on the itemized proposal sheet (bid form) shall be written in ink or typed.
3. The Bidder shall submit a unit price for every item on the itemized proposal sheet. The unit prices for the various contract items shall be written in figures. Unit prices shall be rounded off by the Bidder to contain no more than FOUR decimal places.
4. An amount bid shall be entered on the itemized proposal sheet for every item. The amount bid for each item shall be determined by multiplying each unit bid by the quantity for that item, and shall be written in figures in the "Amount" column of the form.
5. The total amount bid shall be written in figures in the proper place on the bid form. The total amount bid shall be determined by adding the amounts bid for each item.
6. Changes to any entry shall be made by marking through the entry in ink and making the correct entry adjacent thereto in ink. A representative of the Bidder shall initial the change in ink. Do not use correction fluid, correction tape or similar product to make corrections.
7. The bid shall be properly executed on the included **Execution of Bid – Non-collusion Affidavit, Debarment Certification and Gift Ban Certification** form. All bids shall show the following information:
 - a. Name of corporation, partnership, limited liability company, joint venture, individual or firm, submitting bid.
Corporations that have a corporate seal should include it on the bid.
 - b. Name of individual or representative submitting bid and position or title held on behalf of the bidder.
 - c. Name, signature, and position or title of witness.
 - d. Completed attestation by Notary Public**Note: Signer, Witness and Notary Public must be different individuals.**
8. The bid shall not contain any unauthorized additions, deletions, or conditional bids.
9. The Bidder shall not add any provision reserving the right to accept or reject an award, or to enter into a contract pursuant to an award.
10. The Form entitled "LISTING OF DBE SUBCONTRACTORS", or "LISTING OF MBE/WBE SUBCONTRACTORS", must be filled out for Subcontractors submitting quotes for work on this contract. The Contractor shall then submit this form with the bid package.
11. **THE PROPOSAL WITH THE ITEMIZED PROPOSAL SHEET ATTACHED SHALL BE PLACED IN A SEALED ENVELOPE AND SHALL BE DELIVERED TO AND RECEIVED IN THE NCDOT DIVISION PROPOSALS ENGINEER'S OFFICE AT 558 GILLESPIE STREET, FAYETTEVILLE, N. C. 28301 BY 2:00 P.M., JANUARY 18, 2017.**
12. **The sealed bid envelope must display the bidding Contractor's name and address on the front.**
13. The sealed bid must display the following statement on the front of the sealed envelope:

QUOTATION FOR D6D2.SBE.001

**MISC. CONCRETE CONSTRUCTION – CUMBERLAND & HARNETT
2:00 PM ON WEDNESDAY, JANUARY 18, 2017**

14. If delivered by mail, the sealed envelope shall be placed in another sealed envelope and the outer envelope shall be addressed as follows:

**N. C. DEPARTMENT OF TRANSPORTATION
R. ALLEN WADDELL, P.E.
P.O. BOX 1150
FAYETTEVILLE, NC 28302**

PROJECT SPECIAL PROVISIONS

GENERAL:

This contract is for the installation of various concrete structures in Cumberland & Harnett Counties. The contractor is to furnish all labor, material, concrete, equipment and traffic control.

All work and materials shall be in accordance with the provisions of the General Guidelines of this contract, the Project Special Provisions, the North Carolina Department of Transportation Standard Specifications for Roads and Structures 2012, the North Carolina Department of Transportation Roadway Standards Drawings, and the current edition of the Manual of Uniform Traffic Control Devices (MUTCD). The Contractor shall keep himself fully informed of all Federal, State and local laws, ordinances, and regulations, and shall comply with the provisions of Section 107 of the Standard Specifications.

The Department of Transportation does not exclude any person from participation in, deny any person the benefits of, or otherwise discriminate against anyone in connection with the award and performance of any contract covered by this program on the basis of race, color, sex, political affiliation/ influence, or national origin.

Contractor should be aware that total quantities shown are estimated for the purpose of bidding only. Total quantity shown is not guaranteed to the contractor and no claim may be made for insufficient quantities accomplished by the contractor.

The contractor shall coordinate all work with the Department. A pre-construction conference shall be held prior to beginning work.

SMALL BUSINESS ENTERPRISE PROGRAM:

Bids are being solicited for this project under the provisions of NCDOT's **Small Business Enterprise Program**.

Your firm does not have to be formally identified as a minority, woman, or disabled business to qualify for this Program, but you must have had an annual income of \$1,500,000 or less for the previous calendar year.

Under the provisions of this Program, a NC General Contractor's License is not required.

Under the provisions of this Program, contract payment and contract performance bonds are not required.

Under the provisions of this Program, your firm is required to be certified as a SBE Contractor with the Contractual Services Unit of NCDOT, and be listed in the Directory of Transportation Firms, prior to bidding on this contract. Prospective bidders who qualify for the SBE Program and are not currently certified should submit a completed application packet prior to bid submittal to allow for review time. The application packet and additional information on the program may be obtained online at: <https://connect.ncdot.gov/business/SmallBusiness/Pages/default.aspx>.

The Department of Transportation will assume no responsibility for any delays caused prior to the date of availability by any reason whatsoever, and such delays, if any, will not constitute a valid reason for extending the completion date.

AUTHORITY OF THE ENGINEER:

(01-30-14)

105-1

SPD 01-460

The Engineer for this project shall be the Division Engineer, Division 6, Division of Highways, North Carolina Department of Transportation, acting directly or through his duly authorized representative.

The Engineer will decide all questions which may arise as to the quality and acceptability of work performed and as to the rate of progress of the work; all questions which may arise as to the interpretation of the contract; and all questions as to the acceptable fulfillment of the contract on the part of the Contractor. His decision shall be final and he shall have executive authority to enforce and make effective such decisions and orders as the Contractor fails to carry out promptly.

CONTRACT TIME AND LIQUIDATED DAMAGES:

The date of availability for this project shall be the Date of Purchase Order Issue. No work will be permitted and no purchase order will be issued until all required bonds and prerequisite conditions and certifications have been satisfied.

The completion date for this project shall be One Year from the date of Purchase Order Issuance. No extensions will be authorized except as approved by the Engineer.

Liquidated damages for failure to complete individual routes (or route sections) within fourteen (14) calendar days from notification shall be **One Hundred Dollars (\$100.00) per calendar day per route not completed.**

No work may be performed on weekends, Legal State holidays or as directed by the engineer. Work shall only be performed when weather and visibility conditions allow safe operations.

CONTRACT PERIOD:

(2-19-14)

SPD 01-600

This contract shall be effective for one (1) contract period (up to 12 months). At the option of the Department and upon agreement by the Contractor, this contract may be extended for up to two (2) additional one (1) year periods with a five percent (5%) increase in prices each year.

No changes in the terms, condition, etc. of this contract will be made when an extension of the contract is implemented. The Engineer will notify the Contractor in writing prior to renewal of the contract. The Contractor must notify the Engineer in writing within thirty (30) days of notification by the Engineer of his acceptance or rejection of this offer. Failure on the part of the Contractor to reply will be viewed as a rejection of the contract extension.

The Contractor shall provide an ACORD insurance certificate showing a minimum of \$5,000,000 Liability Insurance along with proof of all other legally required insurance.

PROSECUTION AND PROGRESS:

(3-16-10)

108

SPD 1-700

The Contractor shall pursue the work diligently with workmen in sufficient numbers, abilities, and supervision, and with equipment, materials, and methods as may be required to complete the work described in the contract by the completion date and in accordance with the *2012 Standard Specifications*.

The Contractor's operations are restricted to daylight hours. No work may be performed on Saturdays, Sundays and legal State holidays, unless otherwise approved by the Engineer. Work shall only be performed when weather and visibility conditions allow safe operations.

NON-EXCLUSIVE CONTRACT:

(6-1-15)

SPD 01-750

The Department may, as it deems to be in the best interest of the state and the Department of Transportation, execute more than one contract based on this proposal. The Contractor(s) understands and agrees, by signature on the Purchase Order Contract Bid Proposal, that this agreement **does not** constitute an exclusive contract. If awarded, the contracts will be executed with the lowest responsible bidders. The Department of Transportation reserves the right to make multiple awards for the services provided by this contract. Furthermore, the Department reserves the right to reject all bids received.

INTERMEDIATE CONTRACT TIME AND LIQUIDATED DAMAGES:

(2-20-07)

SP1G14A

The Contractor shall complete the required work of installing, maintaining, and removing the traffic control devices for lane closures, narrowing lanes, detaining and/or altering the traffic flow and restoring to a two-lane, two-way traffic pattern. These provisions shall be adhered to from the beginning of the project through project completion. The District Engineer can adjust the time restrictions as necessary. The Contractor shall not close or narrow a lane of traffic during the following time restrictions::

INTERSTATE 95 & FUTURE INTERSTATE 295
DAY AND TIME RESTRICTIONS

Monday thru Thursday
6:00 a.m. thru 9:00 a.m.
4:00 p.m. thru 7:00 p.m.

Friday 6:00 a.m. through Monday 9:00 a.m.

ALL OTHER STATE MAINTAINED ROUTES
DAY AND TIME RESTRICTIONS

Monday thru Friday
6:00 a.m. thru 9:00 a.m.
4:00 p.m. thru 7:00 p.m.

In addition, the Contractor shall not narrow or close a lane of traffic on **ANY STATE MAINTAINED ROUTE**, detain and /or alter the traffic flow on or during holiday weekends, special events, or any other time when traffic is unusually heavy, including the following schedules:

HOLIDAY AND HOLIDAY WEEKEND LANE CLOSURE RESTRICTIONS:

1. For **unexpected occurrence** that creates unusually high traffic volumes, as directed by the Engineer.
2. For **New Year's Day**, between the hours of **4:00 p.m.** December 31st and **8:30 a.m.** January 2nd. If New Year's Day is on a Friday, Saturday, Sunday or Monday, then until **8:30 a.m.** the following Tuesday.
3. For **Martin Luther King, Jr. Day**, between the hours of **4:00 p.m.** Friday and **8:30 a.m.** Tuesday.
4. For **Easter**, between the hours of **4:00 p.m.** Thursday and **8:30 a.m.** Monday.
5. For **Memorial Day**, between the hours of **4:00 p.m.** Friday and **8:30 a.m.** Tuesday.
6. For **Independence Day**, between the hours of **4:00 p.m.** the day before Independence Day and **8:30 a.m.** the day after Independence Day.

If **Independence Day** is on a Friday, Saturday, Sunday or Monday, then between the hours of **4:00 p.m.** the Thursday before Independence Day and **8:30 a.m.** the Tuesday after Independence Day.
7. For **Labor Day**, between the hours of **4:00 p.m.** Friday and **8:30 a.m.** Tuesday.
8. For **Veteran's Day**, between the hours of **4:00 p.m.** Friday and **8:30 a.m.** Tuesday.
9. For **Thanksgiving Day**, between the hours of **4:00 p.m.** Tuesday and **8:30 a.m.** Monday.
10. For **Christmas**, between the hours of **4:00 p.m.** the Friday before the week of Christmas Day and **8:30 a.m.** the following Tuesday after the week of Christmas Day.
11. For **NASCAR Daytona Car Races**, between the hours of **6:00 a.m.** the Friday before the week of the NASCAR Daytona Car Races to **7:00 p.m.** Monday after the week of the NASCAR Daytona Car Races.
12. For the **Daytona Bike Week**, between the hours of **6:00 a.m.** Friday the week before the week of the Daytona Bike Week to **7:00 p.m.** Monday after the week of the Daytona Bike week.
13. For the **Myrtle Beach Bike Weekend**, between the hours of **6:00 a.m.** Thursday before the week of the Myrtle Beach Bike Weekend to **7:00 p.m.** Monday after the weekend of the Myrtle Beach Bike Weekend.

Holidays and holiday weekends shall include New Years, Easter, Memorial Day, Independence Day, Labor Day, Thanksgiving, and Christmas. The Contractor shall schedule his work so that lane closures are not required during these periods, unless otherwise directed by the Engineer.

The time of availability for this intermediate contract work shall be the time the Contractor begins to install all traffic control devices for daytime and nighttime lane closures according to the time restrictions listed above.

The completion time for this intermediate contract work shall be the time the Contractor is required to complete the removal of all traffic control devices according to the time restrictions stated above and place traffic in a two-lane, two-way pattern.

The liquidated damages for this contract time are:

Five Hundred Dollars (\$500.00) per one (1) hour or any portion thereof.

INSPECTION:

All work shall be subject to inspection by the Engineer at any time. Routinely, the Engineer will make periodic inspections of the completed work. It will be the responsibility of the Contractor to keep the Engineer informed of his proposed work plan and to submit written reports of work accomplished on a frequency to be determined by the Engineer.

SUBSURFACE INFORMATION:

(7-1-95)

450

SP1 G112 A

There is **no** subsurface information available on this project. The Contractor shall make his own investigation of subsurface conditions.

UTILITY CONFLICTS:

It shall be the responsibility of the Contractor to contact all affected utility owners and determine the precise locations of all utilities prior to beginning construction. Utility owners shall be contacted a minimum of 48 hours prior to the commencement of operations. Special care shall be used in working around or near existing utilities, protecting them when necessary to provide uninterrupted service. In the event that any utility service is interrupted, the Contractor shall notify the utility owner immediately and shall cooperate with the owner, or his representative, in the restoration of service in the shortest time possible. Existing fire hydrants shall be kept accessible to fire departments at all times.

The contractor shall adhere to all applicable regulations and follow accepted safety procedures when working in the vicinity of utilities in order to insure the safety of construction personnel and the public.

LOCATING EXISTING UNDERGROUND UTILITIES:

(3-20-12)

105

SP1 G115

Revise the *2012 Standard Specifications* as follows:

Page 1-43, Article 105-8, line 28, after the first sentence, add the following:

Identify excavation locations by means of pre-marking with white paint, flags, or stakes or provide a specific written description of the location in the locate request.

DIVISION SIX TRAFFIC SERVICES CONTACT:

Excavation within 500 feet of a signalized intersection will require notification by the contractor to the Division Traffic Services Unit at telephone number (910) 486-1452. All traffic signal or detection cables must be located prior to excavation.

DOMESTIC STEEL:

(4-16-13)

106

SP1 G120

Revise the *2012 Standard Specifications* as follows:

Page 1-49, Subarticle 106-1(B) Domestic Steel, lines 2-7, replace the first paragraph with the following:

All steel and iron products that are permanently incorporated into this project shall be produced in the United States except minimal amounts of foreign steel and iron products may be used provided the combined material cost of the items involved does not exceed 0.1% of the total amount bid for the entire project or \$2,500, whichever is greater. If invoices showing the cost of the material are not provided, the amount of the bid item involving the foreign material will be used for calculations. This minimal amount of foreign produced steel and iron products permitted for use is not applicable to high strength fasteners. Domestically produced high strength fasteners are required.

OUTSOURCING OUTSIDE THE USA:

(9-21-04) (Rev. 5-16-06)

SP1 G150

All work on consultant contracts, services contracts, and construction contracts shall be performed in the United States of America. No work shall be outsourced outside of the United States of America.

Outsourcing for the purpose of this provision is defined as the practice of subcontracting labor, work, services, staffing, or personnel to entities located outside of the United States.

The North Carolina Secretary of Transportation shall approve exceptions to this provision in writing.

IRAN DIVESTMENT ACT:

(5-17-16)

SP01 G151

As a result of the Iran Divestment Act of 2015 (Act), Article 6E, N.C. General Statute § 147-86.55, the State Treasurer published the Final Divestment List (List) which includes the Final Divestment List-Iran, and the Parent and Subsidiary Guidance-Iran. These lists identify companies and persons engaged in investment activities in Iran and will be updated every 180 days. The List can be found at <https://www.nctreasurer.com/inside-the-department/OpenGovernment/Pages/Iran-Divestment-Act-Resources.aspx>

By submitting the Offer, the Contractor certifies that, as of the date of this bid, it is not on the then-current List created by the State Treasurer. The Contractor must notify the Department immediately if, at any time before the award of the contract, it is added to the List.

As an ongoing obligation, the Contractor must notify the Department immediately if, at any time during the contract term, it is added to the List. Consistent with § 147-86.59, the Contractor shall not contract with any person to perform a part of the work if, at the time the subcontract is signed, that person is on the then-current List.

During the term of the Contract, should the Department receive information that a person is in violation of the Act as stated above, the Department will offer the person an opportunity to respond and the Department will take action as appropriate and provided for by law, rule, or contract.

GIFTS FROM VENDORS AND CONTRACTORS:

(12-15-09)

107-1

SP1 G152

By Executive Order 24, issued by Governor Perdue, and *N.C.G.S. § 133-32*, it is unlawful for any vendor or contractor (i.e. architect, bidder, contractor, construction manager, design professional, engineer, landlord, offeror, seller, subcontractor, supplier, or vendor), to make gifts or to give favors to any State employee of the Governor's Cabinet Agencies (i.e. Administration, Commerce, Correction, Crime Control and Public Safety, Cultural Resources, Environment and Natural Resources, Health and Human Services, Juvenile Justice and Delinquency Prevention, Revenue, Transportation, and the Office of the Governor). This prohibition covers those vendors and contractors who:

- (A) Have a contract with a governmental agency; or
- (B) Have performed under such a contract within the past year; or
- (C) Anticipate bidding on such a contract in the future.

For additional information regarding the specific requirements and exemptions, vendors and contractors are encouraged to review Executive Order 24 and *N.C.G.S. § 133-32*.

Executive Order 24 also encouraged and invited other State Agencies to implement the requirements and prohibitions of the Executive Order to their agencies. Vendors and contractors should contact other State Agencies to determine if those agencies have adopted Executive Order 24.

LIABILITY INSURANCE:

(5-20-14)

SP1 G160

Revise the *2012 Standard Specifications* as follows:

Page 1-60, Article 107-15 LIABILITY INSURANCE, line 16, add the following as the second sentence of the third paragraph:

Prior to beginning services, all contractors shall provide proof of coverage issued by a workers' compensation insurance carrier, or a certificate of compliance issued by the Department of Insurance for self-insured subcontractors, irrespective of whether having regularly in service fewer than three employees.

EMPLOYMENT:

(11-15-11) (Rev. 1-17-12)

108, 102

SP1 G184

Revise the *2012 Standard Specifications* as follows:

Page 1-20, Subarticle 102-15(O), delete and replace with the following:

(O) Failure to restrict a former Department employee as prohibited by Article 108-5.

Page 1-65, Article 108-5 Character of Workmen, Methods, and Equipment, line 32, delete all of line 32, the first sentence of the second paragraph and the first word of the second sentence of the second paragraph.

STATE HIGHWAY ADMINISTRATOR TITLE CHANGE:

(9-18-12)

SP1 G185

Revise the *2012 Standard Specifications* as follows:

Replace all references to “State Highway Administrator” with “Chief Engineer”.

SUBLETTING OF CONTRACT:

(11-18-2014)

108-6

SP1 G186

Revise the *2012 Standard Specifications* as follows:

Page 1-66, Article 108-6 Subletting of Contract, line 37, add the following as the second sentence of the first paragraph:

All requests to sublet work shall be submitted within 30 days of the date of availability or prior to expiration of 20% of the contract time, whichever date is later, unless otherwise approved by the Engineer.

Page 1-67, Article 108-6 Subletting of Contract, line 7, add the following as the second sentence of the fourth paragraph:

Purchasing materials for subcontractors is not included in the percentage of work required to be performed by the Contractor. If the Contractor sublets items of work but elects to purchase material for the subcontractor, the value of the material purchased will be included in the total dollar amount considered to have been sublet.

SUPERVISION BY CONTRACTOR:

At all times during the life of the project the Contractor shall provide one permanent employee who shall have the authority and capability for overall responsibility of the project and who shall be personally available at the work site within 24 hours notice. Such employee shall be fully authorized to conduct all business with the Subcontractors, to negotiate and execute all supplemental agreements, and to execute the orders or directions of the Engineer.

At all times that work is actually being performed, the Contractor shall have present on the project one competent individual who is authorized to act in a supervisory capacity over all work on the project, including work subcontracted. The individual who has been so authorized shall be experienced in the type of work being performed and shall be fully capable of managing, directing, and coordinating the work; of reading and thoroughly understanding the contract; and receiving and carrying out directions from the Engineer or his authorized representatives. He shall be an employee of the Contractor unless otherwise approved by the Engineer.

The Contractor may, at his option, designate one employee to meet the requirements of both positions. However, whenever the designated employee is absent from the work site, an authorized individual qualified to act in a supervisory capacity on the project shall be present.

EQUIPMENT:

The Contractor shall furnish all equipment in good operating condition, and shall be operated by properly trained and qualified personnel. The Contractor shall be responsible for all costs or charges incurred in the operation and maintenance of the equipment during the performance of this contract. Upon request, the contractor shall provide any and all state and federal certifications for equipment safety.

Payment for equipment and labor required to perform bid items is included in the bid item price provided by the contractor. Mobilization of labor and equipment shall be included in the bid item price provided by the contractor.

CONFORMITY WITH THE CONTRACT:

The presence of the engineer or an inspector at the work site shall in no way lessen the contractor’s responsibility for conformity with the provisions of this contract. Should the engineer or inspector fail to point out work that does not conform with the plans and

specifications, whether from lack of discovery or for any other reason, it shall in no way prevent later rejection or correction to the unsatisfactory work when discovered. The contractor shall have no claim for losses suffered due to any necessary removals or repairs resulting from unsatisfactory work.

PAYMENT AND RETAINAGE:

The **INVOICE** along with – **SUBCONTRACTOR PAYMENT INFORMATION** shall be completed for each month work is performed and shall be submitted to the Department. Upon verification, the Engineer will submit the invoice for payment.

Invoices shall be submitted to:

Lee R. Hines, Jr., P.E.
NC DOT
Division 6 - District 2
P.O. Box 1150
Fayetteville, NC 28306

FLAGGERS:

Provide the service of properly equipped and qualified flaggers, in accordance with Section 1150 of the Standard Specifications and *Roadway Standard Drawing* 1150.01, at locations and times for such period as necessary for the control and protection of vehicular and pedestrian traffic. Anyone who controls traffic is required to be qualified. Qualification consists of each flagger receiving proper training in the set-up and techniques of safely and competently performing a flagging operation. Qualification of flaggers is to be done by an NCDOT approved training agency. For a complete listing of these, see the Work Zone Traffic Control's webpage, <http://www.ncdot.gov/doh/preconstruct/wztc/>.

Prior to beginning work on the project, a Qualification Statement that all flaggers used on the project have been properly trained through an NCDOT approved training resource shall be provided to the Engineer.

Flagging operations are not allowed for the convenience of the Contractor's operations. However, if safety issues exist (i.e. sight or stopping sight distance), the Engineer may approve the use of flagging operations. Use flagging methods that comply with the guidelines in the MUTCD.

PROJECT SPECIAL PROVISIONS**ROADWAY****NOTES TO CONTRACTOR:**

1. Bids are being solicited for this project under the provisions of NCDOT's **Small Business Enterprise Program**.
2. Contract payment and performance bonds are not required for this contract.
3. Portable work zone signing consistent with a flagging operation is acceptable. Stationary work zone signing will not be required.
4. The Contractor shall not close more than one lane at a time without prior approval from the Engineer.
5. Operate equipment and conduct operations in the same direction as the flow of traffic.
6. Contractor shall be responsible for the purchase and placement of the concrete materials, including the concrete mix and expansion joints. No separate payment shall be made for those items, as they shall be considered incidental to the different types of structures.

DRIVEWAYS AND PRIVATE PROPERTY:

The Contractor shall maintain access to driveways for all residents and property owners throughout the duration of the project.

The Contractor shall not perform work for private citizens or agencies in conjunction with this project or within the project limits of this contract.

TRAFFIC SIGNS & MAILBOXES:

Permanent traffic signs and mailboxes that interfere with the road construction operations are to be removed during the course of a day's work, and be reinstalled at the conclusion of each work day. The Contractor shall mark the proper location of the signs and mailboxes by placing an offset stake behind the ditch line to ensure proper replacement.

INTERPRETATION OF QUANTITIES IN BID FORM:

The quantities appearing in the bid form are approximate only and are to be used for the comparison of bids. Payment to the Contractor will be made only for the actual quantities of the various items that are completed and accepted in accordance with the terms of the contract.

Projects will become available throughout the year at various locations in Robeson County. The department will notify the winning bidder when work is available.

COOPERATION WITH STATE FORCES AND OTHER CONTRACTORS:

The Contractor must cooperate with State forces and other Contractors working within the limits of this project as directed by the Engineer.

PRESERVATION OF PROPERTY:

The Contractor shall exercise care to avoid damage to all public and private property and facilities. Any damage to properties, such as, but not limited to, mailboxes, fences, gates, vehicles, driveways, etc. shall immediately be restored to the previously existing condition by the contractor. No payment will be made to the Contractor for such restorative work.

LITTERING ON PROJECT:

The discarding of trash other than in acceptable trash containers will be considered littering and will not be tolerated on NCDOT projects. Violators will be subject to penalty under State Laws.

WASTE MATERIAL DISPOSAL:

All construction waste material shall be removed from the project site prior to 100% project completion. All waste disposal shall be in accordance with federal, state and local regulations regarding the disposal of waste material(s). All permit and fees for any such disposal shall be the responsibility of the Contractor, and NCDOT shall not be held liable for any such disposal of material(s).

WBS ELEMENTS:

When invoicing, refer to the bullets below for appropriate designations:

- 6.102611 (Cumberland County Primary Routes)
- 6.202611 (Cumberland County Secondary Routes)
- 6.202621 (Cumberland County Unpaved Secondary Routes)
- 6.102631 (Cumberland County Interstate Routes)
- 6.104311 (Harnett County Primary Routes)
- 6.204311 (Harnett County Secondary Routes)
- 6.204321 (Harnett County Unpaved Secondary Routes)
- 6.104331 (Harnett County Interstate Routes)

GRADING:

The Contractor is to grade area to the typical sections and details shown or directed by the Engineer. Grading shall be defined in Section 226 of the Standard Specifications for Roads and Structures 2012 or amendments thereof, as amended herein, and shall include all grading work necessary to construct the project including but not limited to clearing and grubbing, roadway excavation, embankment construction, shoulder construction, fine grading, and shaping, grading and compacting roadway ditches, tail ditches, slopes and subgrade. **There shall be no direct payment for grading as grading shall be incidental to all miscellaneous concrete construction.**

EROSION, SILTATION, AND POLLUTION CONTROL:

The Contractor shall exercise every reasonable precaution and take all necessary measures throughout the life of the project to prevent erosion, siltation, and pollution in accordance with Section 107-13 of the Standard Specifications for Roads and Structures 2012 or amendments thereof. Erosion control measures shall be installed and maintained in accordance with the plans for this project, Division 16 of the Standard Specifications, Section 1630 of the Standard Specifications, the NCDOT Best Management Practices for Construction and Maintenance Activities or amendments thereof and in locations directed by the Engineer or his representative.

The NCDOT Best Management Practices for Construction and Maintenance Activities manual can be found on the Internet at the following web address:

http://ncdot.org/doh/operations/BMP_manual/default.html

ROUTINE MOBILIZATION:

The Contractor will be notified when services are needed by the Engineer, and shall begin work **within fourteen (14) Calendar Days after notification, or as determined by the Engineer**. Failure to respond within the designated time frame for the routine service, or as approved by the Engineer, may result in cancellation of this contract.

Routine Mobilization will not be paid separately, but shall be considered to be incidental to other contract items.

EMERGENCY CALL BACK MOBILIZATION:

A separate bid item will be used for **Emergency Call Back Mobilization**. The contractor shall include a cost for mobilizing on emergency basis. Under this item the contractor shall respond after first initially being contacted by the Engineer to the required areas **within three (3) Calendar Days**. Failure to respond within the time frame may result in nonpayment of this item as emergency basis.

Basis of payment will be the contract unit price per each for Emergency Call Back Mobilization.

MISCELLANEOUS:

All work items necessary to complete the work other than listed on the "Bid Proposal Form" will be considered incidental in nature and no further compensation will be made. Any work performed in an unsatisfactory manner shall be basis for cancellation of the contract.

All work performed by the contractor shall be in compliance with the Standard Specifications and Workmanship/Appearance done to the satisfaction of the Engineer.

Under the terms of this contract for multiple awards, NCDOT has the right to move to the next low bidder that was issued this contract, provided one exists, for such things as, but not limited to:

1. Non-responsiveness to the Engineer's call to work within the allotted or agreed to time frame.
2. Lack of quality control or supervision.
3. Lack of proper equipment to perform the required task.
4. Equipment malfunctions or breakdowns.
5. Inadequate or insufficient number of crew members.

INCIDENTAL CONCRETE CONSTRUCTION - GENERAL

Incidental concrete construction shall meet the general requirements in accordance with Section 825 of the Standard Specifications. Maintain forms true to the required lines, grades and dimensions. Construct forms with material of such strength and with sufficient rigidity to prevent any appreciable deflection between supports. No concrete shall be placed until the foundation, the adequacy of the forms, the placing of reinforcement and other embedded items have been inspected and approved by the Engineer. The temperature of the concrete shall not be less than 50 degrees Fahrenheit at the time of placement. The air temperature measured at the job site, in the shade, away from artificial heat shall be a minimum of 35 degrees Fahrenheit and rising before placement will be permitted. The Contractor shall cure the concrete in accordance with Section 825-9 of the Standard Specifications.

UNDERCUT EXCAVATION:

When the Engineer determines that the finish graded roadway cross section contains undesirable material, the Contractor shall remove the material and backfill with suitable, properly compacted material. Payment for undercut excavation will be made only in areas that have been examined and approved by the Engineer. Work shall be done in accordance with Section 225 of the Standard Specifications.

Excavation will be measured and paid in cubic yards of materials, measured in their original position and computed by the average end method. The Contractor shall not exceed a depth of three (3) feet when excavating unsuitable material. Foundation Conditioning Geotextile shall be utilized in these areas or as directed by the Engineer. All excess material shall be disposed of in accordance with Section 802 of the Standard Specifications.

Payment to the contractor will be full compensation for all work involving undercut excavation and hauling and disposing of materials.

Basis of payment for "Undercut Excavation" will be the unit bid price per cubic yard.

BORROW:

The work covered by this item consists of the furnishing and excavation of an approved material from a contractor supplied location for use as a backfill material. Payment will be on cubic yard basis by truck measurement. The quantity of borrow excavation to be paid will be the actual number of cubic yards of approved material, measured in trucks, which has been excavated from the borrow source and incorporated into the completed and accepted work. The recorded capacity of any truck used to transport the material will be adjusted by making a 25% deduction to allow for shrinkage and the adjusted capacity will be the quantity paid for. Contractor furnished borrow and waste sites shall comply with section 230 of the Standard Specifications. **A copy of the borrow source permit shall be provided to the inspector prior to hauling any materials.**

Basis of payment for "Borrow Excavation" will be the unit bid price per cubic yard.

REMOVAL AND DISPOSAL OF EXISTING CONCRETE AND ASPHALT:

In accordance with Section 250 of the Standard Specifications for Roads and Structures 2012 or amendments thereof, break up, remove and satisfactorily dispose of the asphalt and portland cement concrete components within the limits shown on the plans or as directed by the engineer. Removal of existing asphalt and concrete will be measured and paid for in square yards of existing asphalt and concrete actually removed and disposed of properly. Removal of existing asphalt and concrete will be measured by actual surface measurement prior to removal. Any material removed from the project shall be done in accordance with Section 802 of the Standard Specifications for Roads and Structures 2012 or amendments thereof.

Basis of payment for "Removal of Existing Concrete" and "Removal of Existing Asphalt" will be the unit bid price per square yard.

AGGREGATE BASE COURSE:

The Contractor shall furnish and place aggregate base course in accordance with the provisions of Section 520 of the Standard Specifications for Roads and Structures 2012 and to the typical sections and details shown.

The Contractor shall dry or add moisture to the material when required to provide a uniformly compacted and acceptable base. When completed, the base course shall be smooth, hard, dense, unyielding and well bonded. All disturbed areas shall be properly compacted in accordance Section 520-7 of the Standard Specifications for Roads and Structures 2012.

Payment will be made under the item "Aggregate Base Course" and shall include, but not be limited to, furnishing aggregate with water, mixing, hauling, spreading materials, compacting, shaping and maintaining the base course.

Basis of payment for "Aggregate Base Course" will be the unit bid price per ton.

CONCRETE CURB AND GUTTER:

All concrete curb and gutter shall be constructed in accordance with Section 846 of the Standard Specifications for Roads and Structures 2012 and the current Roadway Standard Drawing 2012 846.01 or amendments thereof or as directed by the Engineer.

Concrete shall be Class B, and the concrete shall be given a light broom finish with the brush marks parallel to the curb line or gutter line. Concrete shall be of a North Carolina Department of Transportation approved mix design dispatched from a currently certified production facility. No concrete shall be placed until the forms and base have been inspected and approved by the Department of Transportation. Curb and gutter placed by machine shall not be placed until the stringline and base have been inspected and approved by the Department of Transportation.

Curb and Gutter continuous sections that are longer than 50 feet must be placed with the use of a curb machine or slip forms.

The contractor shall be required to replace curb and gutter within 48 hours after removal of that portion of existing curb and gutter. If curb and gutter is not replaced the same day that it is removed, the contractor shall "safe-up" the work area as directed by the Engineer.

Payment for this item will be full compensation for all grading and excavation necessary to construct the curb and gutter, materials and labor for construction of the curb and gutter, and any other incidentals associated with the construction of the curb and gutter. **There shall be no direct payment for any grading and/or excavation involved with the installation and or construction of any concrete curb and gutter.**

Basis of payment for 2'-6" Concrete Curb and Gutter, 1'-6" Concrete Curb and Gutter, 8" X 12" or 18" Concrete Curb, 9" X 12" or 18" Concrete Curb, 8" X 6" Median Curb, Shoulder Berm Gutter, 2' Concrete Valley Gutter or 4' Concrete Expressway Gutter will be the unit price bid per linear foot.

CONCRETE SIDEWALKS:

All concrete sidewalks shall be constructed in accordance with Section 848 of the Standard Specifications for Roads and Structures 2012 and the current Roadway Standard Drawing 2012 848.01 or amendments thereof or as directed by the Engineer.

Use Class B concrete where required or as directed by the Engineer. Concrete shall be of a North Carolina Department of Transportation approved mix design dispatched from a currently certified production facility. The concrete shall be given a light broom finish with the brush marks traverse to the direction of traffic. Concrete shall be of a North Carolina Department of

Transportation approved mix design dispatched from a currently certified production facility. No concrete shall be placed until the forms and base have been inspected and approved by the Department of Transportation.

Payment for this item will be full compensation for grading necessary to construct the sidewalk, materials and labor for construction of the sidewalk, and any other incidentals associated with the construction of the sidewalk. **There shall be no direct payment for any grading involved with the installation and or construction of any concrete sidewalk.**

Basis of payment for "Concrete Sidewalk" will be the unit bid price per square yard. The Concrete Sidewalk will be measured along the surface of the completed and accepted work.

CONCRETE CURB RAMPS:

Curb ramps shall be installed in accordance with the Americans with Disabilities Act (ADA), Section 848 of the Standard Specifications, and the current NCDOT Roadway Standard Drawing 848.05, or as directed by the Engineer.

Use Class B concrete where required or as directed by the Engineer. Concrete shall be of a North Carolina Department of Transportation approved mix design dispatched from a currently certified production facility. The concrete shall be given a light broom finish with the brush marks traverse to the direction of traffic. No concrete shall be placed until the forms and base have been inspected and approved by the Department of Transportation.

Detectable warnings shall be installed in accordance with Section 848 and may be either truncated dome concrete paving blocks or stamped concrete. The installation of detectable warnings shall be considered incidental to the installation of the concrete curb ramps.

Payment for this item will be full compensation for all grading and excavation necessary to construct the wheelchair ramps; materials and labor for construction of the ramps; and any other incidentals associated with the construction of the wheelchair ramps. **There shall be no direct payment for any grading and/or excavation involved with the installation and or construction of any concrete curb ramp.**

Basis of payment for "Concrete Curb Ramps" will be the unit bid price per each.

DETECTABLE WARNINGS FOR PROPOSED CURB RAMPS:

(6-15-10) (Rev. 8-16-11)

848

SP8 R126

Description

Construct detectable warnings consisting of integrated raised truncated domes on proposed concrete curb ramps in accordance with the *2012 Standard Specifications*, plan details, the requirements of the *28 CFR Part 36 ADA Standards for Accessible Design* and this provision.

Materials

Detectable warning for proposed curb ramps shall consist of integrated raised truncated domes. The description, size and spacing shall conform to Section 848 of the *2012 Standard Specifications*.

Use material for detectable warning systems as shown herein. Material and coating specifications must be stated in the Manufacturers Type 3 Certification and all Detectable Warning systems must be on the NCDOT Approved Products List.

Install detectable warnings created from one of the following materials: precast concrete blocks or bricks, clay paving brick, gray or ductile iron castings, mild steel, stainless steel, and engineered plastics, rubber or composite tile. Only one material type for detectable warning will be permitted per project, unless otherwise approved by the Engineer.

- (A) Detectable Warnings shall consist of a base with integrated raised truncated domes, and when constructed of precast concrete they shall conform to the material requirements of Article 848-2 of the *2012 Standard Specifications*.
- (B) Detectable Warnings shall consist of a base with integrated raised truncated domes, and may be comprised of other materials including, but not limited to, clay paving brick, gray iron or ductile iron castings, mild steel, stainless steel, and engineered plastics, rubber or composite tile, which are cast into the concrete of the curb ramps. The material shall have an integral color throughout the thickness of the material. The detectable warning shall include fasteners or anchors for attachment in the concrete and shall be furnished as a system from the manufacturer.

Prior to installation, the Contractor shall submit to the Engineer assembling instructions from the manufacturer for each type of system used in accordance with Article 105-2 of the *2012 Standard Specifications*. The system shall be furnished as a kit containing all consumable materials and consumable tools, required for the application. They shall be capable of being affixed to or anchored in the concrete curb ramp, including green concrete (concrete that has set but not appreciably hardened). The system shall be solvent free and contain no volatile organic compounds (VOC). The static coefficient of friction shall be 0.8 or greater when measured on top of the truncated domes and when measured between the domes in accordance with ASTM C1028 (dry and wet). The system shall be resistant to deterioration due to exposure to sunlight, water, salt or adverse weather conditions and impervious to degradation by motor fuels, lubricants and antifreeze.

- (C) When steel or gray iron or ductile iron casting products are provided, only products that meet the requirements of Subarticle 106-1(B) of the *2012 Standard Specifications* may be used. Submit to the Engineer a Type 6 Certification, catalog cuts and installation procedures at least 30 days prior to installation for all.

Construction Methods

- (A) Prior to placing detectable warnings in proposed concrete curb ramps, adjust the existing subgrade to the proper grade and in accordance with Article 848-3 of the *2012 Standard Specifications*.
- (B) Install all detectable warning in proposed concrete curb ramps in accordance with the manufacturer's recommendations.

Measurement and Payment

Detectable Warnings installed for construction of proposed curb ramps will not be paid for separately. Such payment will be included in the price bid for *Concrete Curb Ramps*.

CONCRETE DRIVEWAY TURNOUT (RADIUS TYPE):

All concrete driveway turnouts shall be constructed in accordance with Section 848 of the Standard Specifications and the current NCDOT Roadway Standard Drawings. Concrete shall be Class B, and the concrete shall be given a light broom finish with the brush marks traverse to the direction of traffic. Concrete shall be of a NCDOT approved mix design dispatched from a currently certified production facility. No concrete shall be placed until the forms and base have been inspected and approved by the Department of Transportation.

Payment for this item will be full compensation for fine grading necessary to construct the driveways, materials and labor for construction of the driveways, incidental concrete to tie into existing driveways as directed by the Engineer, and any other incidentals associated with the construction of the driveways. **There shall be no direct payment for any grading and/or excavation involved with the installation and or construction of any concrete driveway turnout.**

Basis of payment for 6" Concrete Driveway Turn-Out will be the unit bid price per square yard.

4" CONCRETE PAVED DITCH:

Concrete paved ditch shall be constructed in accordance with Section 850 of the Standard Specifications for Roads and Structures 2012 and the current Roadway Standard Drawing 850.01 or amendments thereof or as directed by the Engineer.

Use Class B concrete where required or as directed by the Engineer. Concrete shall be of a North Carolina Department of Transportation approved mix design dispatched from a currently certified production facility. The concrete shall be given a light broom finish with the brush marks traverse to the direction of traffic. No concrete shall be placed until the forms and base have been inspected and approved by the Department of Transportation.

Payment for this item will be full compensation for grading and excavation necessary to construct the paved ditch, materials and labor for construction of the paved ditch, and any other incidentals associated with the construction of the paved ditch. **There shall be no direct payment for any grading and/or excavation involved with the installation and or construction of any concrete paved ditch.**

Basis of payment for 4" Concrete Paved Ditch will be the unit bid price per square yard. Longitudinal measurements will be made along the surface of the pavement at the centerline of the ditch and transverse measurements will be made along the surface of the pavement at right angles to the centerline. No measurements will be made of curtain walls at the beginning or ends of the paved ditches.

CONCRETE DRIVEWAY APRONS:

All concrete driveway aprons shall be constructed in accordance with Section 848 of the Standard Specifications and the current NCDOT Roadway Standard Drawings. Aprons shall be constructed to the width and length dimensions specified by the Engineer. Depth of concrete shall be 6" and expansion joints shall be constructed at 10-15' intervals as directed by the Engineer. Concrete shall be Class B, and the concrete shall be given a light broom finish with the brush marks traverse to the direction of traffic. Concrete shall be of a NCDOT approved mix design dispatched from a currently certified production facility. No concrete shall be placed until the forms and base have been inspected and approved by the Department of Transportation.

Payment for this item will be full compensation for all fine grading necessary to construct the driveways, materials and labor for construction of the driveways, incidental concrete to tie into existing driveways as directed by the Engineer, and any other incidentals associated with the construction of the driveway apron. **There shall be no direct payment for any grading and/or excavation involved with the installation and or construction of any concrete driveway apron.**

Basis of payment will be the unit price bid per square yard under 6" Concrete Driveway Apron.

MONOLITHIC CONCRETE ISLAND:

The Contractor shall construct a 5-inch monolithic island in accordance with Section 852 of the Standard Specifications, Roadway Standard Drawing 852.01, the contract, and plans. Class B concrete of a currently approved North Carolina Department of Transportation mix design shall be used. Concrete shall be given a sidewalk finish with brooming done transverse to the direction of traffic.

The island shall be anchored to the existing pavement surface with 40d spikes driven into the surface and staggered on 2-foot centers. The Contractor shall place 1/2" expansion joints at 30-foot interval, joints 1 inch deep at 10-foot intervals between the expansion joints. The top 1/2" of expansion joints and the full depth of grooved joints shall be filled and sealed with a North Carolina Department of Transportation approved joint sealer.

The Contractor shall place at locations in the island, as directed by the Engineer, 12" PVC Pipe, to facilitate installation of sign posts. The PVC pipe shall be in place prior to placement of concrete, shall be plumb, and shall be cut off flush with the top surface of the island.

All concrete shall be formed and placed in accordance with Section 420 of the Standard Specifications. **No concrete shall be placed until the forms and concrete have been approved by the Engineer or his representative.** The temperature of the concrete shall not be less than 50 degrees Fahrenheit at the time of placement. The air temperature measured at the job site, in the shade, away from artificial heat shall be a minimum of 35 degrees Fahrenheit before placement will be permitted. The Contractor shall cure the concrete in accordance with Section 420-17 of the Standard Specifications.

Payment for this item will be full compensation for all grading and excavation necessary to construct the monolithic concrete islands, materials and labor for and any other incidentals associated with the construction of the monolithic concrete islands. **There shall be no direct payment for any grading and/or excavation involved with the installation and or construction of any monolithic concrete island.**

Basis of payment for 5" Monolithic Concrete Islands will be the unit bid price per square yards. Measurement will be made parallel to the bottom surface of the island.

TRAFFIC CONTROL AND WORK ZONE SAFETY:

The Contractor shall maintain traffic during construction and provide, install, and maintain all traffic control devices in accordance with these project guidelines, the Project Special Provisions, Division 10, 11 and 12 of the North Carolina Department of Transportation Standard Specifications for Roads and Structures 2012 and the current edition of the Manual of Uniform Traffic Control Devices (MUTCD).

The Contractor shall utilize complete and proper traffic controls and traffic control devices **including but not limited to flashing arrow panels (boards), type C**, during all applicable operations. All traffic control and traffic control devices required for any operation shall be functional and in place prior to the commencement of that operation. Signs for temporary operations shall be removed during periods of inactivity. The Contractor is required to leave the project in a manner that will be safe to the traveling public and which will not impede motorists.

Install Work Zone Advance Warning Signs in accordance with the detail drawing provided in these plans prior to beginning any other work. Use a lane closure or slow moving operation to complete the work, as necessary, unless otherwise indicated. Refer to Standard

Drawing No. 1101.02, 1101.11, 1110.01, 1110.02, 1130.01 1135.01 and 1180.01 of the Roadway Standard Drawings 2012. Use a moving operation only if the minimum speed maintained at all times is 3 mph with no stops that narrow or close a lane of travel. If the moving operation is progressing slower than 3 mph at any time, install a lane closure. Maintain the existing traffic pattern at all times, except in the immediate work zone where lane closures are allowed as determined by the Engineer. **The utilization of flashing arrow panels (boards), type C will be considered incidental to the single lane and multi-lane closure line items. No direct payment will be made for the utilization of flashing arrow panels (boards), type C as they will be considered incidental to the single lane and multi-lane closure line items.**

Refer to attached details and Standard Drawing No. 1101.02, 1101.03, 1101.04, 1101.05, 1101.11, 1110.01, 1110.02, 1115.01, 1130.01, 1135.01, 1145.01, 1150.01, 1165.01, and 1180.01 of the Roadway Standard Drawings 2012 when closing a lane of travel in a stationary work zone such as pavement patching resurfacing, or pavement marking removal. Properly ballasted cones and skinny drums may be used instead of drums. However, drums are required for the upstream taper portion of lane closures in all applications. The stationary work zone shall be a maximum of 1 mile in length at any given time on 2 Lane, 2 Way facilities unless otherwise approved by the Engineer. A pilot vehicle operation may be used in conjunction with flaggers and the appropriate pilot vehicle warning signing as directed by the Engineer. During periods of construction inactivity, return the traffic pattern to the existing alignment and remove or cover any work zone signs. When covering work zone signs, use an opaque material that prevents reading of the sign at night by a driver using high beam headlights. Use material, which does not damage the sign sheeting. Replace any obliterated markings as required by other sections of the Standard Specifications for Roads and Structures 2012 and the Engineer.

When personnel and/or equipment are working on the shoulder adjacent to and within 5 feet of an open travel lane, close the nearest open travel lane using Standard Drawing No. 1101.02 of the Roadway Standard Drawings 2012. When personnel and/or equipment are working within a lane of travel of an undivided facility, close the lane according to the traffic control plans, Roadway Standard Drawings 2012 or as directed by the Engineer. Conduct the work so that all personnel and/or equipment remain within the closed travel lane. Do not work simultaneously, on both sides of an open travel way, within the same location, on a two-lane, two-way road. Perform work only when weather and visibility conditions allow safe operations as directed by the Engineer.

Install advance/general warning work zone signs according to the Detail Drawing provided in these plans prior to beginning of work. Install and maintain signing in accordance with the attached drawings and Divisions 11 and 12 of the Standard Specifications for Roads and Structures 2012.

ROAD CLOSURES ARE NOT PERMITTED AT ANY TIME

Conduct the work so that all personnel and/or equipment remain within the closed travel lane. Do not work simultaneously, on both sides of an open travel way, within the same location, on a two-lane, two-way road. Do not perform work involving heavy equipment within 15 feet of the edge of travel way when work is being performed behind a lane closure on the opposite side of the travel way. Perform work only when weather and visibility conditions allow safe operations as directed by the Engineer.

Once the Contractor has started- work at a location, the Contractor should prosecute the work in a continuous and uninterrupted manner from the time he begins the work until completion and final acceptance unless determined otherwise by the Engineer. Obtain written approval of the Engineer before working in more than one location or setting up additional lane closures.

Traffic movements through lane closures on roads with two way traffic shall be controlled by flaggers stationed at each end of the work zone. In situations where sight distance is limited, the Contractor shall provide additional means of controlling traffic, including, but not limited to, two-way radios, pilot vehicles, or additional flaggers. Flaggers shall be competent personnel, adequately trained in flagging procedures, and furnished with proper safety devices and equipment, including, but not limited to, safety vests and stop/slow paddles.

Place all changeable message signs as needed in the locations and with the word messages as directed by the Engineer to provide advance warning to the public during construction.

Ensure the Oversize/Overweight Permit Unit (919) 733-4740 has been advised if the ongoing traffic operations through the Division office.

All personnel when working in traffic areas or areas in close proximity to traffic shall wear an approved safety vest, or shirt or jacket which meets the color requirements of the Manual of Uniform Traffic Control Devices (MUTCD).

The Contractor shall comply with all applicable Federal, State, and local laws, ordinances, and regulations governing safety, health, and sanitation, and shall provide all safeguards, safety devices, and protective equipment, and shall take any other needed actions, on his own responsibility that are reasonably necessary to protect the life and health of employees on the job and the safety of the public, and to protect property in connection with the performance of the work covered by the contract.

Failure to comply with any of the requirements for safety and traffic control of this contract shall result in suspension of work as provided in subarticle 108-7(2) of the Standard Specifications for Roads and Structures 2012.

All contractor personnel will be required to wear a Class II ANSI approved safety vest while working within the NCDOT Right of Way.

Payment for single lane closures and/or multi-lane closures will be full compensation for all labor, equipment and other associated items necessary to set up, maintain and remove any single lane and/or multi-lane closures to include but limited to portable signs, cones, drums, skinny drums, flaggers, and flashing arrow panels (boards), type C.

Payment for portable changeable message boards (CMB), truck mounted impact attenuators (TMIA) and portable light plants will be full compensation for all labor, equipment and other associated items necessary to set up, maintain and remove these items.

NCDOT WORK ZONE TRAFFIC CONTROL QUALIFICATIONS AND TRAINING PROGRAM

This program requires qualified and trained Work Zone Flaggers in every flagging operation (July 2010) and qualified and trained Work Zone Traffic Control Supervisors on Significant Projects (July 2011). It is intended for the program to include anyone working within NCDOT Right of Way including work associated with NCDOT construction and encroachment agreements as well as all NCDOT operations.

Training for this certification will be provided by NCDOT approved training sources and/or private entities that have been pre-approved to train themselves. Additional information will be provided as this program progresses. If you have questions, visit our web site at www.ncdot.org/~wztc, or contact Stuart Bourne, PE with NCDOT Traffic Management Unit at (919) 662-4338 or sbourne@ncdot.gov.

Basis of payment for “Single Lane Closure”, “Multi-lane Closure”, “Portable Changeable Message Board (CMB)”, “Truck Mounted Impact Attenuator (TMIA)” and “Portable Light Plant” will be the unit bid price per each / per operation / per day.

PAVEMENT REPAIRS:

Any pavement repairs required by work under this contract will be performed by North Carolina Department of Transportation forces.

STATE OF NORTH CAROLINA DEPT. OF TRANSPORTATION DIVISION OF HIGHWAYS RALEIGH, N.C.

ENGLISH STANDARD DRAWING FOR CONCRETE CURB, GUTTER AND CURB & GUTTER

SHEET 1 OF 3 846.01

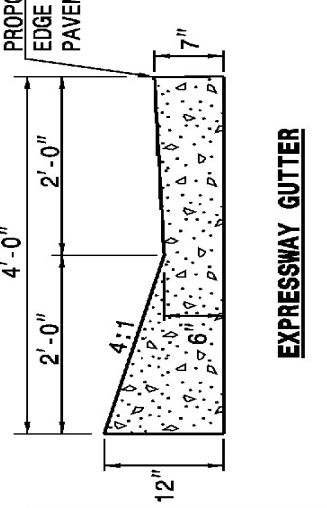
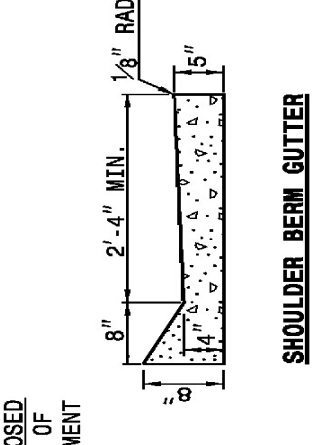
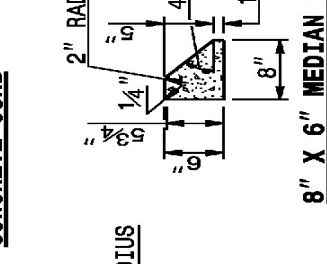
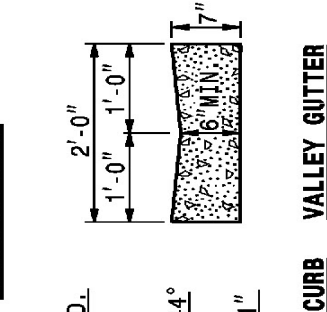
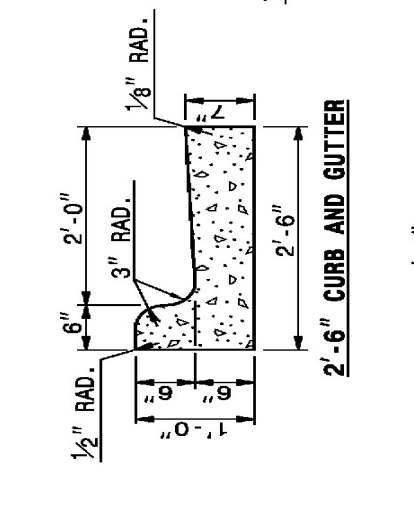
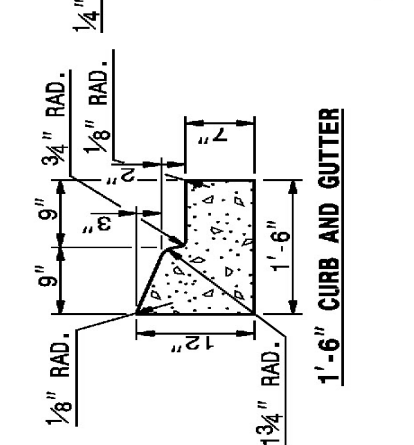
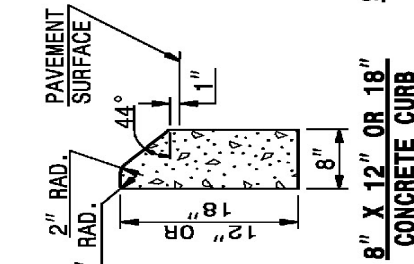
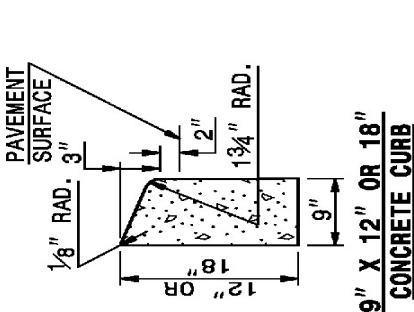

SECTION VIEW OF CURBS OR CURBS AND GUTTERS

- GENERAL NOTES:
- PLACE CONTRACTION JOINTS AT 10' INTERVALS, EXCEPT THAT A 15' SPACING MAY BE USED WHEN A MACHINE IS USED OR WHEN SATISFACTORY SUPPORT FOR THE FACE FORM CAN BE OBTAINED WITHOUT THE USE OF TEMPLATES AT 10' INTERVALS.
 - JOINT SPACING MAY BE ALTERED IF REQUIRED BY THE ENGINEER.
 - CONTRACTION JOINTS MAY BE INSTALLED WITH THE USE OF TEMPLATES OR FORMED BY OTHER APPROVED METHODS.
 - CONSTRUCT NON-TEMPLATE FORMED JOINTS A MIN. OF 1 1/2" DEEP.
 - FILL ALL CONSTRUCTION JOINTS, EXCEPT IN 8"X6" MEDIAN CURB, WITH JOINT FILLER AND SEALER.
 - SPACE EXPANSION JOINTS AT 90' INTERVALS AND ADJACENT TO ALL RIGID OBJECTS.

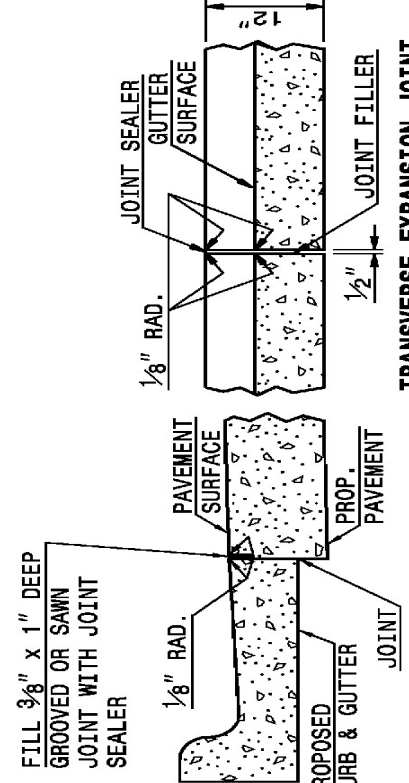

SECTION VIEW OF JOINTS

STATE OF NORTH CAROLINA DEPT. OF TRANSPORTATION DIVISION OF HIGHWAYS RALEIGH, N.C.

ENGLISH STANDARD DRAWING FOR CONCRETE CURB, GUTTER AND CURB & GUTTER

SHEET 1 OF 3 846.01

STATE OF NORTH CAROLINA DEPT. OF TRANSPORTATION DIVISION OF HIGHWAYS RALEIGH, N.C.

ENGLISH STANDARD DRAWING FOR CONCRETE CURB, GUTTER AND CURB & GUTTER

SHEET 2 OF 3 846.01

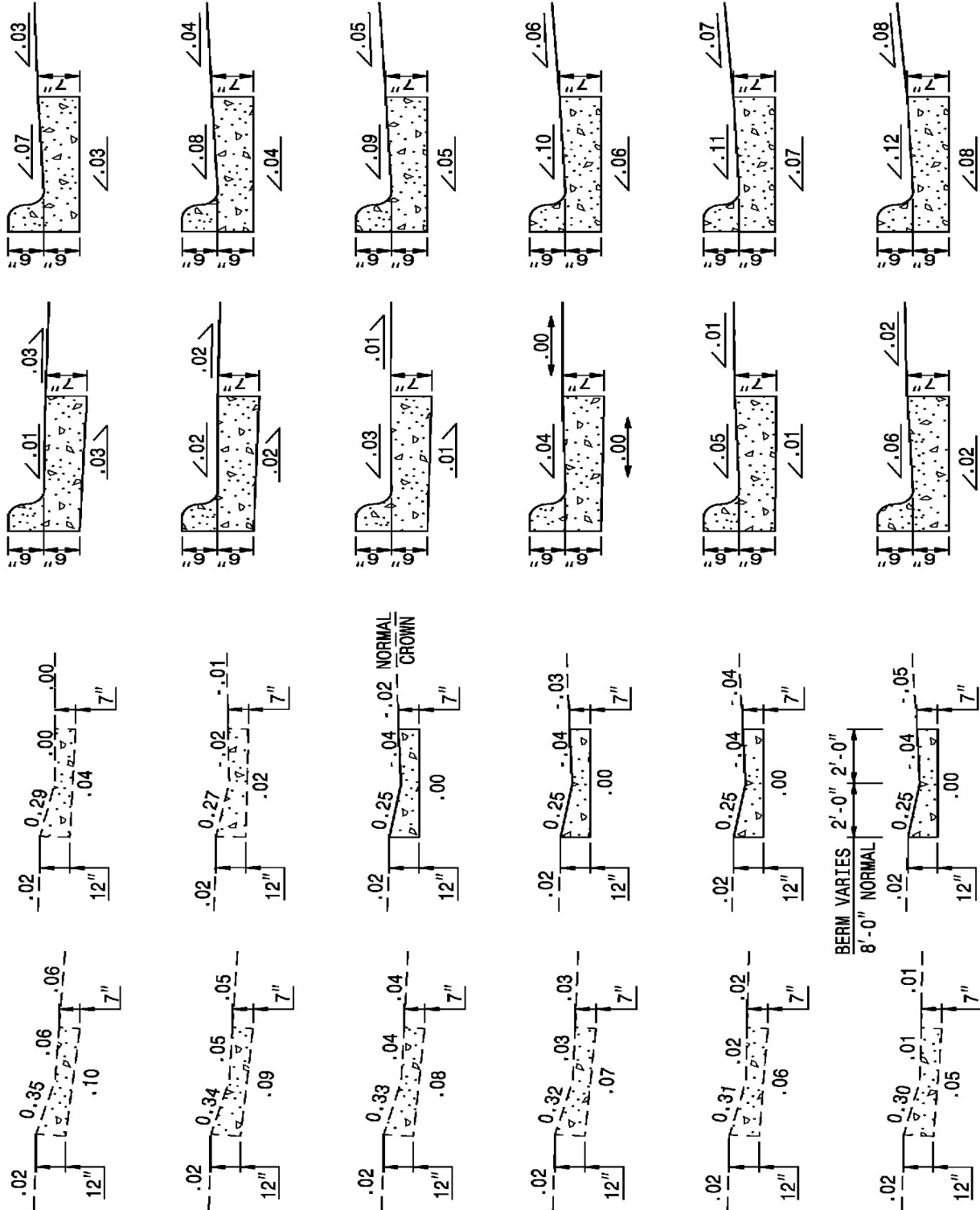

SECTION VIEWS OF EXPRESSWAY GUTTER IN SUPER ELEVATION

SECTION VIEWS OF 2'-6" CURB AND GUTTER SUPERELEVATION RATES

STATE OF NORTH CAROLINA DEPT. OF TRANSPORTATION DIVISION OF HIGHWAYS RALEIGH, N.C.

ENGLISH STANDARD DRAWING FOR CONCRETE CURB, GUTTER AND CURB & GUTTER

SHEET 2 OF 3 846.01

STATE OF NORTH CAROLINA DEPT. OF TRANSPORTATION DIVISION OF HIGHWAYS RALEIGH, N.C.

ENGLISH STANDARD DRAWING FOR CONCRETE CURB, GUTTER AND CURB & GUTTER

SHEET 3 OF 3 846.01

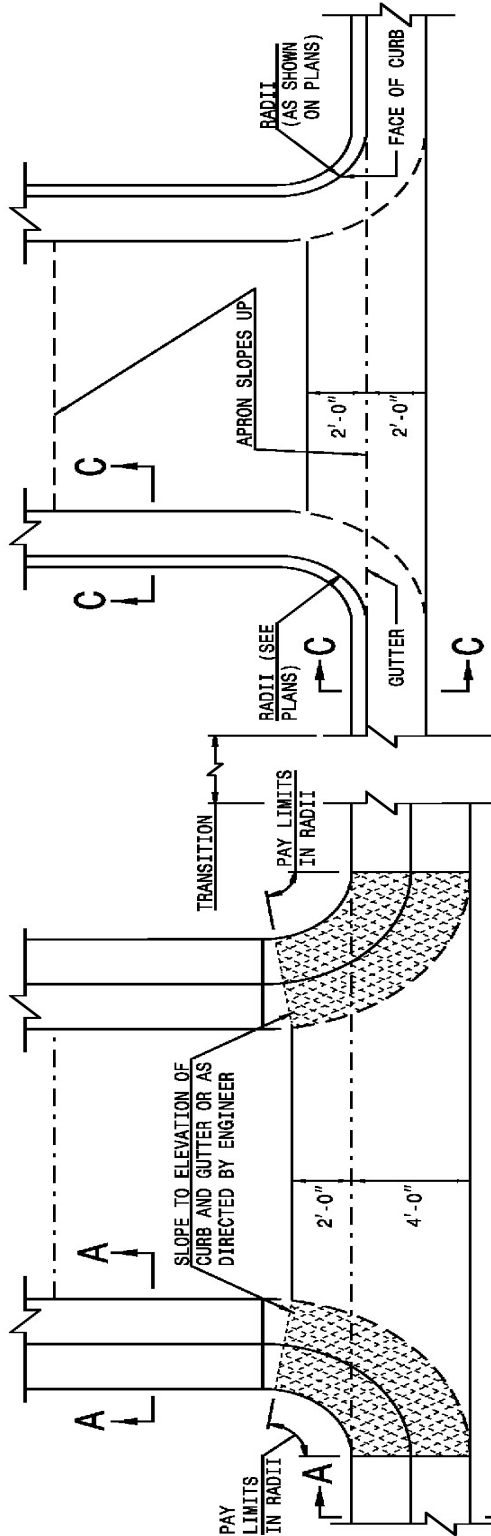

PLAN VIEW OF TYPICAL CURB AND GUTTER OCCURRENCES

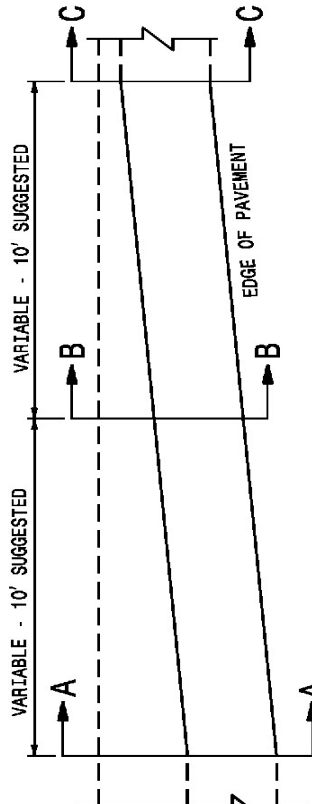
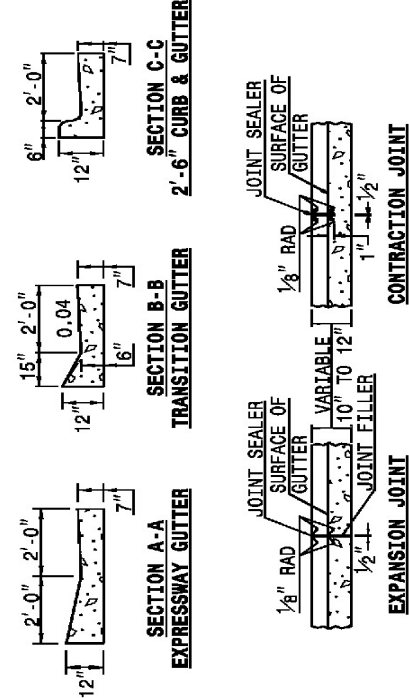

PLAN VIEW OF TRANSITION EXPRESSWAY GUTTER TO 2'-6" CURB AND GUTTER

- NOTES:
- IN THE TRANSITION FROM 4'-0" CONCRETE EXPRESSWAY GUTTER TO 2'-6" CONCRETE CURB AND GUTTER, PLACE 1/2" EXPANSION JOINTS AT 25' INTERVALS.
 - PLACE GROOVE JOINTS 1" DEEP AT 12'-6" INTERVALS BETWEEN EXPANSION JOINTS.
 - FILL AND SEAL THE TOP 1/2" OF THE EXPANSION JOINTS AND 1" OF CONTRACTION JOINTS WITH APPROVED JOINT SEALING COMPOUND.

STATE OF NORTH CAROLINA DEPT. OF TRANSPORTATION DIVISION OF HIGHWAYS RALEIGH, N.C.

ENGLISH STANDARD DRAWING FOR CONCRETE CURB, GUTTER AND CURB & GUTTER

SHEET 3 OF 3 846.01

STATE OF
NORTH CAROLINA
DEPT. OF TRANSPORTATION
DIVISION OF HIGHWAYS
RALEIGH, N.C.

ENGLISH STANDARD DRAWING FOR
CONCRETE SIDEWALK

SHEET 1 OF 1
848.01

NOTES:
CONSTRUCT STANDARD SIDEWALK 5' WIDE AND
4" THICK UNLESS OTHERWISE DENOTED ON PLANS.

PLACE A GROOVE JOINT 1" DEEP WITH 1/8" RADII
IN THE CONCRETE SIDEWALK AT 5' INTERVALS.
ONE 1/2" EXPANSION JOINT WILL BE REQUIRED AT 50'
INTERVALS. A 1/2" EXPANSION JOINT WILL BE REQUIRED
WHERE THE SIDEWALK JOINS ANY RIGID STRUCTURE.

SEE STD. DWG. 848.05 FOR WHEELCHAIR RAMP LOCATION
REQUIREMENTS AND CONSTRUCTION GUIDELINES.

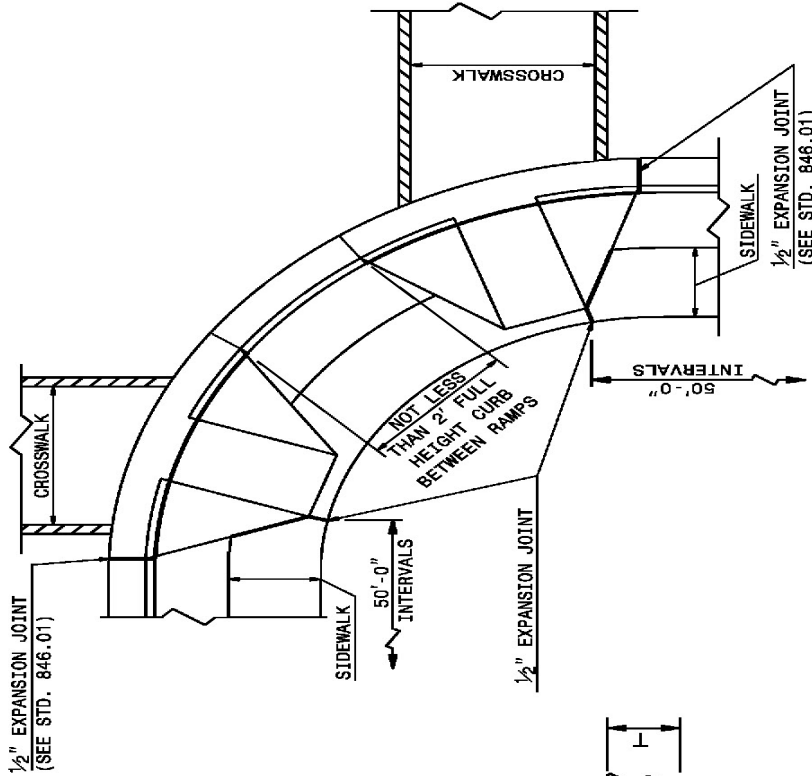

PLAN VIEW

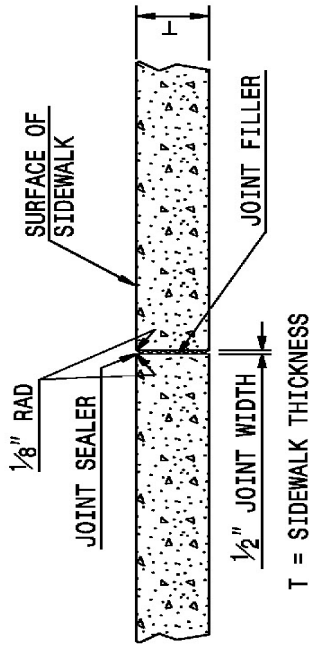

**TRANSVERSE EXPANSION JOINT
IN SIDEWALK**

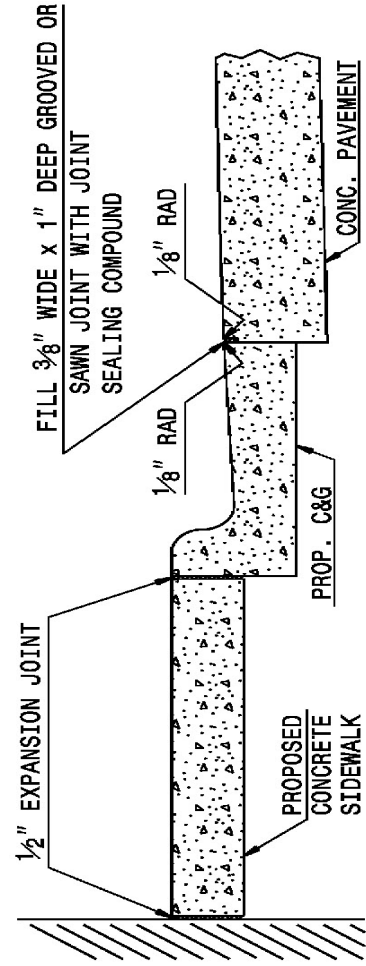

DETAILS SHOWING JOINTS IN CONCRETE SIDEWALK

STATE OF
NORTH CAROLINA
DEPT. OF TRANSPORTATION
DIVISION OF HIGHWAYS
RALEIGH, N.C.

ENGLISH STANDARD DRAWING FOR
CONCRETE SIDEWALK

SHEET 1 OF 1
848.01

STATE OF NORTH CAROLINA DEPT. OF TRANSPORTATION DIVISION OF HIGHWAYS RALEIGH, N.C.

ENGLISH STANDARD DRAWING FOR DRIVEWAY TURNOUT RADIUS TYPE

SHEET 1 OF 2 848.02

* SIDEWALK TAPERS DOWN 5' BACK FROM DRIVEWAY.

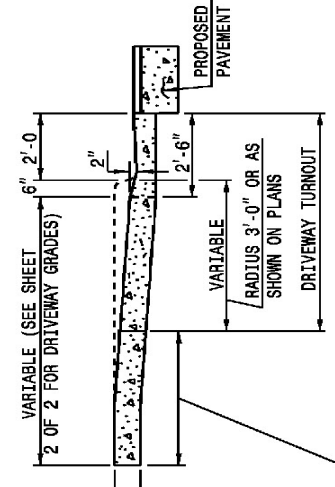
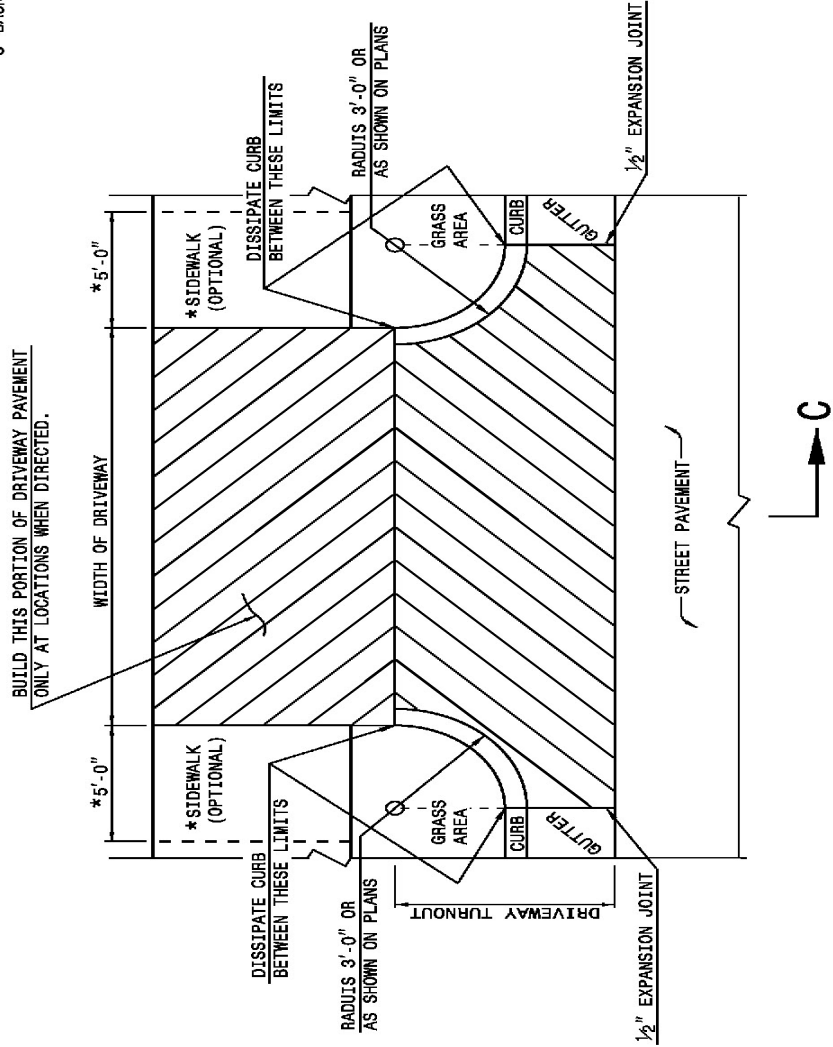

PLAN
DETAIL OF DRIVEWAY

BUILD THIS PORTION OF DRIVEWAY PAVEMENT ONLY AT LOCATIONS WHEN DIRECTED.

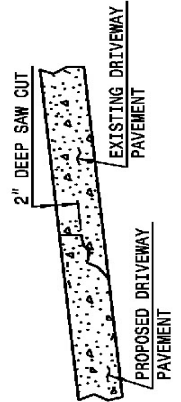

METHOD OF TIE IN

WHEN EXISTING DRIVEWAY PAVEMENT IS CONCRETE, SAW CUT 2" DEEP JOINT AT THE POINT OF TIE-IN. SAW JOINT PERPENDICULAR TO EDGE OF EXISTING DRIVEWAY PAVEMENT.

SECTION C-C

STATE OF NORTH CAROLINA DEPT. OF TRANSPORTATION DIVISION OF HIGHWAYS RALEIGH, N.C.

ENGLISH STANDARD DRAWING FOR DRIVEWAY TURNOUT RADIUS TYPE

SHEET 1 OF 2 848.02

STATE OF NORTH CAROLINA
 DEPT. OF TRANSPORTATION
 DIVISION OF HIGHWAYS
 RALEIGH, N.C.

ENGLISH STANDARD DRAWING FOR
DRIVEWAY TURNOUT
 DRIVEWAY GRADES

SHEET 2 OF 2
848.02

DESIRABLE DRIVEWAY GRADES

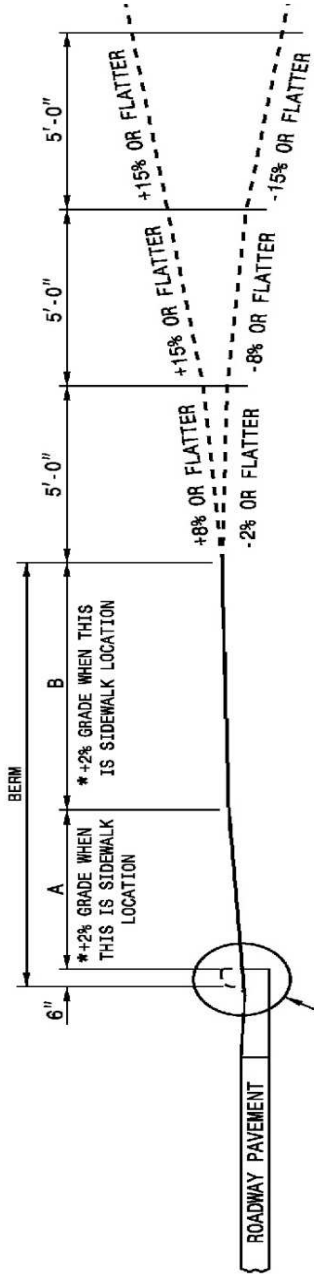

DESIRABLE OR MAXIMUM DRIVEWAY GRADES			
BERM WIDTH	A		B
	DIST.	GRADE	DIST.
8' OR LESS	5'-0"	+2%*	2'-6"
8' OR LESS	2'-0"	+6%	5'-6"
10'	4'-0"	+4%	5'-6"
12' & OVER	4'-6"	+4%	7'-0"

*SIDEWALK LOCATION
 (DO NOT PLACE SIDEWALK ON
 BERMS LESS THAN 6' WIDE.)

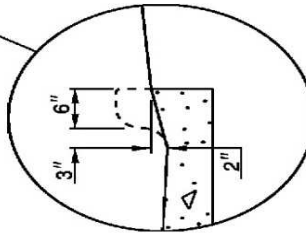

MAXIMUM DRIVEWAY GRADES

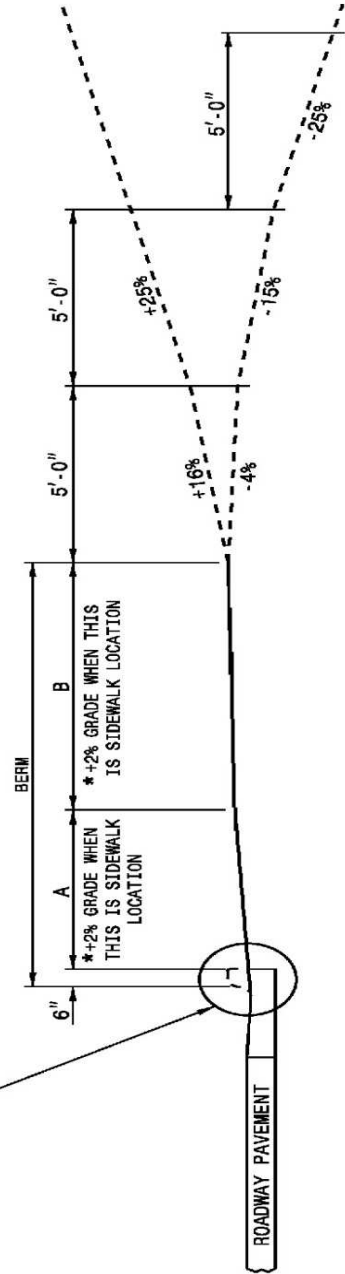

STATE OF NORTH CAROLINA
 DEPT. OF TRANSPORTATION
 DIVISION OF HIGHWAYS
 RALEIGH, N.C.

ENGLISH STANDARD DRAWING FOR
DRIVEWAY TURNOUT
 DRIVEWAY GRADES

SHEET 2 OF 2
848.02

STATE OF NORTH CAROLINA
DEPT. OF TRANSPORTATION
DIVISION OF HIGHWAYS
RALEIGH, N.C.

ENGLISH STANDARD DRAWING FOR
CURB RAMP
PROPOSED CURB AND GUTTER

SHEET 1 OF 3
848.05

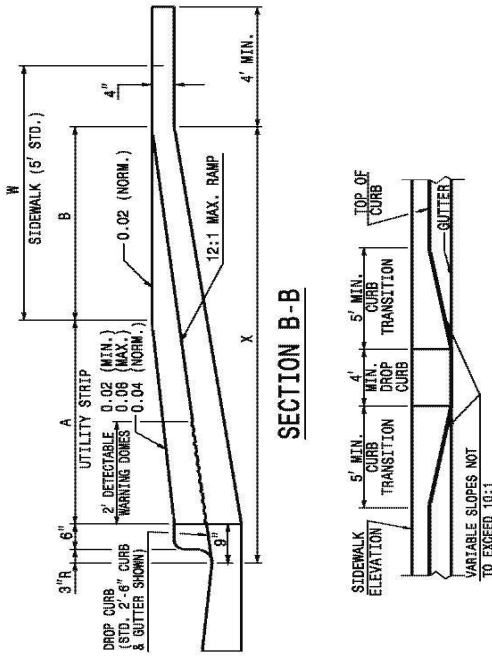

SECTION A-A

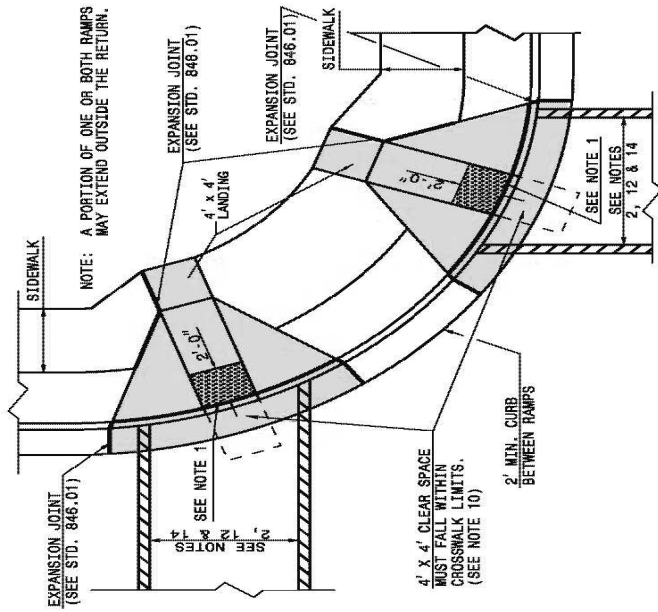

PLAN VIEW
DUAL RAMPS
ANY RADIUS
(4' MIN. FLOOR WIDTH)

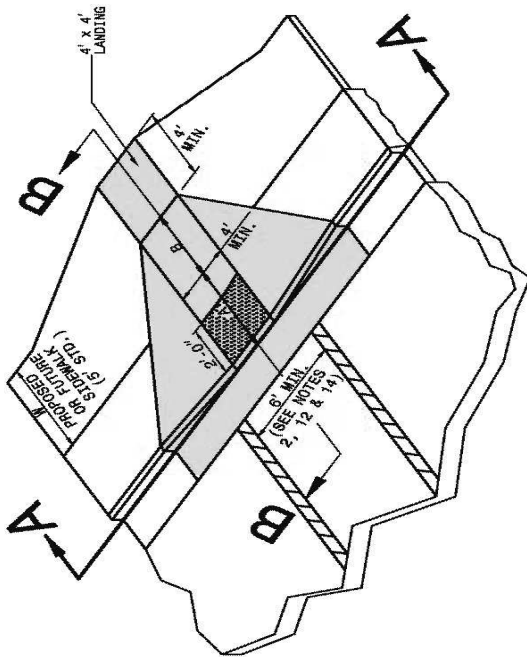

ISOMETRIC VIEW

PAY LIMITS FOR CURB RAMP

NOTES:

1. DETECTABLE WARNING DOMES WILL COVER 2'-0" LENGTH AND FULL WIDTH OF THE RAMP FLOOR AS SHOWN ON THE DETAILS.
2. DETECTABLE WARNING DOMES WILL CONTRAST VISIBILITY WITH ADJOINING SURFACE, EITHER LIGHT-ON-DARK, OR DARK-ON-LIGHT SEQUENCE COVERING THE ENTIRE RAMP.

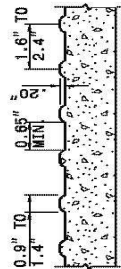
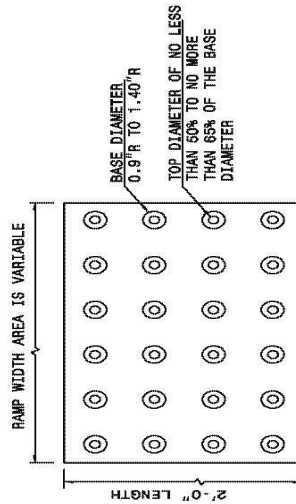

DETECTABLE WARNING DOMES

W	A	X	B
5'	0.0'	5.8'	5.0'*
6'	0.0'	6.8'	6.0'***
7'	0.0'	7.8'	7.3' 6.5'***
8'	0.0'	8.8'	7.3' 6.5'***
5'	2.0'	7.8'	7.8' 5.0'
5'	2.5'	8.3'	8.1' 4.8'
5'	3.0'	8.8'	8.3' 4.4'
5'	3.5'	9.3'	8.4' 4.1'
5'	4.0'	9.8'	8.6' 3.8'
5'	4.5'	10.3'	8.7' 3.4'
5'	5.0'	10.8'	8.8' 3.1'

B = X - (A+9")

B = DISTANCE FROM FRONT EDGE OF SIDEWALK TO BACK POINT OF 12:1 (8.33%) SLOPE.

* BACK OF SIDEWALK DROP REQUIRED FOR ALL SIDEWALK SLOPES.

** BACK OF SIDEWALK DROP REQUIRED FOR SIDEWALK SLOPES 0.04.

STATE OF NORTH CAROLINA
DEPT. OF TRANSPORTATION
DIVISION OF HIGHWAYS
RALEIGH, N.C.

ENGLISH STANDARD DRAWING FOR
CURB RAMP
PROPOSED CURB AND GUTTER

SHEET 1 OF 3
848.05

STATE OF NORTH CAROLINA DEPT. OF TRANSPORTATION DIVISION OF HIGHWAYS RALEIGH, N.C.

ENGLISH STANDARD DRAWING FOR CONCRETE PAVED DITCHES

SHEET 1 OF 1 850.01

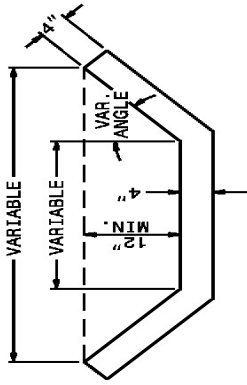

BASE DITCH OR BERM DRAINAGE OUTLET DITCH

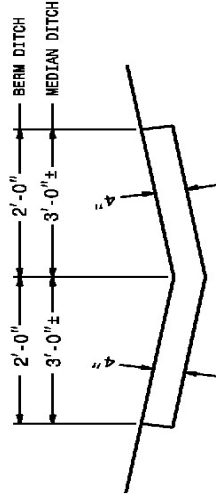

MEDIAN OR BERM DITCH

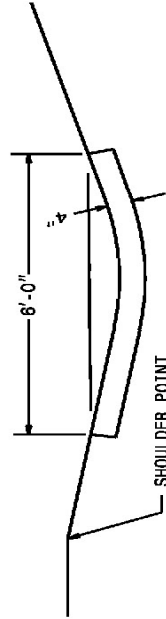

SIDE DITCH

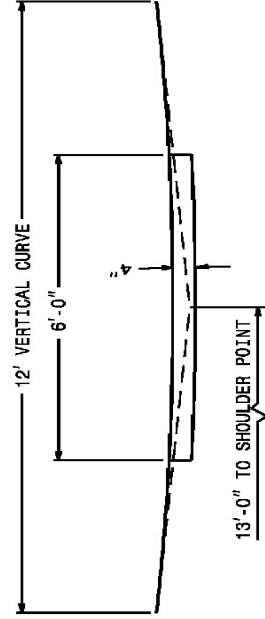

12' V.C. ROADWAY DITCH

GENERAL NOTES:
 IN THE 4" CONC. PAVED DITCHES, PLACE 1/2" EXPANSION JOINTS AT 30' INTERVALS AND AT ALL OTHER POINTS WHERE PROPOSED DITCHES ABUT RIGID OBJECTS. PLACED GROOVED JOINTS 1" DEEP AT 10' INTERVALS BETWEEN EXPANSION JOINTS.

CONSTRUCT WIDTH AND SHAPE OF PROPOSED 4" CONCRETE PAVED DITCHES AS SHOWN OR AS DIRECTED BY THE ENGINEER.

FOR DITCH GRADES ABOVE 2% EROSION CONTROL, INSTALL MATTING ON BOTH SIDES OF THE PAVING FOR A MINIMUM WIDTH OF 36" OR AS DIRECTED BY THE ENGINEER.

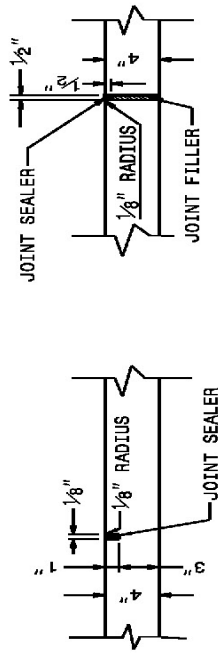

SHOWING GROOVED JOINT SHOWING EXPANSION JOINT

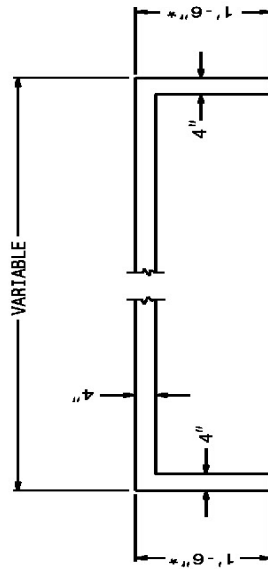

PART LONGITUDINAL SECTION OF PAVED DITCH SHOWING 1'-6" CURTAIN WALL REQUIRED AT EACH END

* WHEN CURTAIN WALL FOR PAVED DITCH IS LOCATED ADJACENT TO A DRAINAGE STRUCTURE AND THE PIPE FROM THE STRUCTURE INTERFERES WITH THE 1'-6" DEPTH, THE DEPTH OF THE CURTAIN WALL MAY BE REDUCED BELOW 1'-6" TO CLEAR THE TOP OF THE PIPE.

STATE OF NORTH CAROLINA DEPT. OF TRANSPORTATION DIVISION OF HIGHWAYS RALEIGH, N.C.

ENGLISH STANDARD DRAWING FOR CONCRETE PAVED DITCHES

SHEET 1 OF 1 850.01

STATE OF NORTH CAROLINA DEPT. OF TRANSPORTATION DIVISION OF HIGHWAYS RALEIGH, N.C.

ENGLISH STANDARD DRAWING FOR CONCRETE ISLANDS

SHEET 1 OF 1 852.01

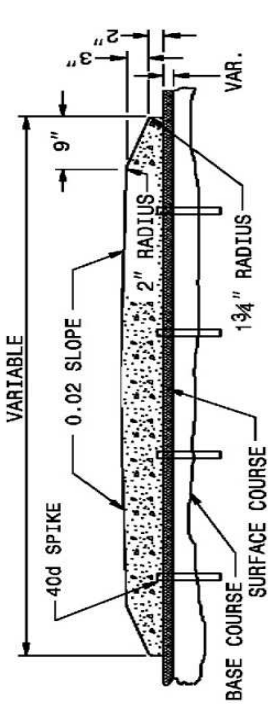

5" MONOLITHIC CONCRETE ISLAND (SURFACE MOUNTED) ON ASPHALT CONCRETE PAVEMENT
(USE ON ISLAND 4' WIDE OR GREATER)

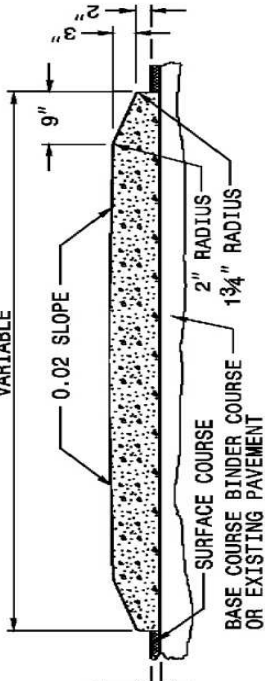

5" MONOLITHIC CONCRETE ISLAND (KEYED IN) ON ASPHALT CONCRETE PAVEMENT
(USE ON ISLAND LESS THAN 4' WIDE)

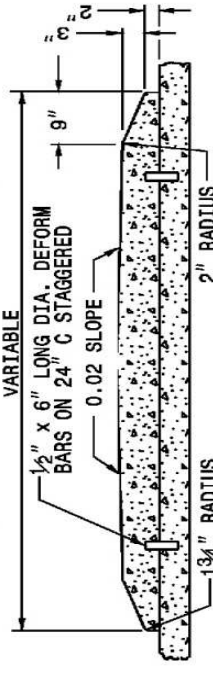

5" MONOLITHIC CONCRETE ISLAND (SURFACE MOUNTED) ON CONCRETE PAVEMENT

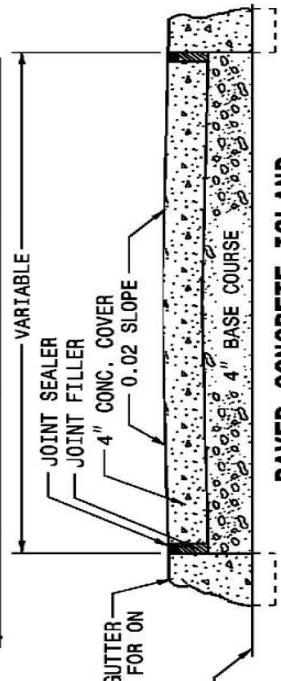

PAVED CONCRETE ISLAND

SEE TYPICAL SECTIONS FOR PAVEMENT DEPTH. KEY IN ON THE LAST LAYER OF PAVEMENT SURFACE COURSE

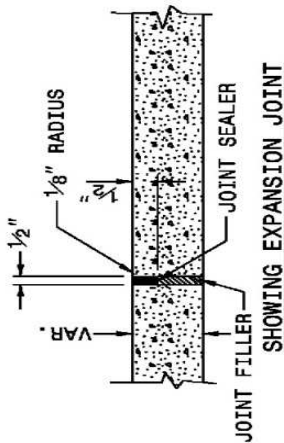

SHOWING EXPANSION JOINT

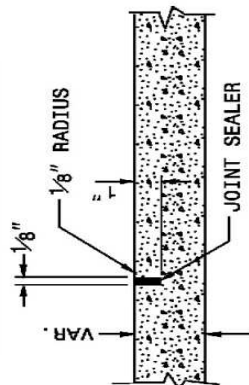

SHOWING GROOVED JOINT

PARTIAL LONGITUDINAL SECTIONS OF PAVED ISLANDS

NOTE:

WHEN MONOLITHIC CONCRETE ISLAND IS ON TOP OF SURFACE COURSE, DRIVE 40d SPIKES INTO SURFACE UNDER MONOLITHIC CONCRETE ISLAND. STAGGER SPIKES ON 2' CENTERS EACH WAY. IN THE CONCRETE PAVEMENT (ISLAND) AND CONCRETE ISLAND (MONOLITHIC) PLACE 1/2" EXPANSION JOINTS AT 30' INTERVALS AND GROOVED JOINTS 1" DEEP AT 10' INTERVALS BETWEEN EXPANSION JOINTS.

LINE UP THE JOINTS IN THE CONCRETE PAVEMENT (ISLAND) WITH THE JOINTS IN THE CURB OR CURB AND GUTTER. FILL AND SEAL THE TOP 1/2" OF THE EXPANSION JOINTS AND THE ENTIRE DEPTH OF GROOVED JOINTS WITH JOINT SEALER.

FOR JOINTS IN THE CURB AND/OR CURB AND GUTTER, SEE STANDARD NO. 846.01

STATE OF NORTH CAROLINA DEPT. OF TRANSPORTATION DIVISION OF HIGHWAYS RALEIGH, N.C.

ENGLISH STANDARD DRAWING FOR CONCRETE ISLANDS

SHEET 1 OF 1 852.01

STANDARD SPECIAL PROVISIONS**AVAILABILITY OF FUNDS – TERMINATION OF CONTRACTS:**

(5-20-08)

Z-2

General Statute 143C-6-11. (h) Highway Appropriation is hereby incorporated verbatim in this contract as follows:

(h) Amounts Encumbered. – Transportation project appropriations may be encumbered in the amount of allotments made to the Department of Transportation by the Director for the estimated payments for transportation project contract work to be performed in the appropriation fiscal year. The allotments shall be multiyear allotments and shall be based on estimated revenues and shall be subject to the maximum contract authority contained in *General Statute 143C-6-11(c)*. Payment for transportation project work performed pursuant to contract in any fiscal year other than the current fiscal year is subject to appropriations by the General Assembly. Transportation project contracts shall contain a schedule of estimated completion progress, and any acceleration of this progress shall be subject to the approval of the Department of Transportation provided funds are available. The State reserves the right to terminate or suspend any transportation project contract, and any transportation project contract shall be so terminated or suspended if funds will not be available for payment of the work to be performed during that fiscal year pursuant to the contract. In the event of termination of any contract, the contractor shall be given a written notice of termination at least 60 days before completion of scheduled work for which funds are available. In the event of termination, the contractor shall be paid for the work already performed in accordance with the contract specifications.

Payment will be made on any contract terminated pursuant to the special provision in accordance with Subarticle 108-13(E) of the *2012 Standard Specifications*.

ERRATA:

(1-17-12) (Rev. 04-21-15)

Z-4

Revise the *2012 Standard Specifications* as follows:

Division 2

Page 2-7, line 31, Article 215-2 Construction Methods, replace “Article 107-26” with “Article 107-25”.

Page 2-17, Article 226-3, Measurement and Payment, line 2, delete “pipe culverts,”.

Page 2-20, Subarticle 230-4(B), Contractor Furnished Sources, change references as follows: Line 1, replace “(4) Buffer Zone” with “(c) Buffer Zone”; **Line 12**, replace “(5) Evaluation for Potential Wetlands and Endangered Species” with “(d) Evaluation for Potential Wetlands and Endangered Species”; and **Line 33**, replace “(6) Approval” with “(4) Approval”.

Division 3

Page 3-1, after line 15, Article 300-2 Materials, replace “1032-9(F)” with “1032-6(F)”.

Division 4

Page 4-77, line 27, Subarticle 452-3(C) Concrete Coping, replace “sheet pile” with “reinforcement”.

Division 6

Page 6-7, line 31, Article 609-3 Field Verification of Mixture and Job Mix Formula Adjustments, replace “30” with “45”.

Page 6-10, line 42, Subarticle 609-6(C)(2), replace “Subarticle 609-6(E)” with “Subarticle 609-6(D)”.

Page 6-11, Table 609-1 Control Limits, replace “Max. Spec. Limit” for the Target Source of $P_{0.075}/P_{be}$ Ratio with “1.0”.

Page 6-40, Article 650-2 Materials, replace “Subarticle 1012-1(F)” with “Subarticle 1012-1(E)”

Division 7

Page 7-1, Article 700-3, CONCRETE HAULING EQUIPMENT, line 33, replace “compation” with “completion”.

Division 8

Page 8-23, line 10, Article 838-2 Materials, replace “Portland Cement Concrete, Class B” with “Portland Cement Concrete, Class A”.

Division 10

Page 10-166, Article 1081-3 Hot Bitumen, replace “Table 1081-16” with “Table 1081-2”, replace “Table 1081-17” with “Table 1081-3”, and replace “Table 1081-18” with “Table 1081-4”.

Division 12

Page 12-7, Table 1205-3, add “FOR THERMOPLASTIC” to the end of the title.

Page 12-8, Subarticle 1205-5(B), line 13, replace “Table 1205-2” with “Table 1205-4”.

Page 12-8, Table 1205-4 and 1205-5, replace “THERMOPLASTIC” in the title of these tables with “POLYUREA”.

Page 12-9, Subarticle 1205-6(B), line 21, replace “Table 1205-4” with “Table 1205-6”.

Page 12-11, Subarticle 1205-8(C), line 25, replace “Table 1205-5” with “Table 1205-7”.

Division 15

Page 15-4, Subarticle 1505-3(F) Backfilling, line 26, replace “Subarticle 235-4(C)” with “Subarticle 235-3(C)”.

Page 15-6, Subarticle 1510-3(B), after line 21, replace the allowable leakage formula with the following: $W=LD\sqrt{P} \div 148,000$

Page 15-6, Subarticle 1510-3(B), line 32, delete “may be performed concurrently or” and replace with “shall be performed”.

Page 15-17, Subarticle 1540-3(E), line 27, delete “Type 1”.

Division 17

Page 17-26, line 42, Subarticle 1731-3(D) Termination and Splicing within Interconnect Center, delete this subarticle.

Revise the *2012 Roadway Standard Drawings* as follows:

1633.01 Sheet 1 of 1, English Standard Drawing for Matting Installation, replace “1633.01” with “1631.01”.

PLANT AND PEST QUARANTINES:

(Imported Fire Ant, Gypsy Moth, Witchweed, Emerald Ash Borer, And Other Noxious Weeds)

(3-18-03) (Rev. 12-20-16)

Z-04a

Within Quarantined Area

This project may be within a county regulated for plant and/or pests. If the project or any part of the Contractor's operations is located within a quarantined area, thoroughly clean all equipment prior to moving out of the quarantined area. Comply with federal/state regulations by obtaining a certificate or limited permit for any regulated article moving from the quarantined area.

Originating in a Quarantined County

Obtain a certificate or limited permit issued by the N.C. Department of Agriculture/United States Department of Agriculture. Have the certificate or limited permit accompany the article when it arrives at the project site.

Contact

Contact the N.C. Department of Agriculture/United States Department of Agriculture at 1-800-206-9333, 919-707-3730, or <http://www.ncagr.gov/plantindustry/> to determine those specific project sites located in the quarantined area or for any regulated article used on this project originating in a quarantined county.

Regulated Articles Include

1. Soil, sand, gravel, compost, peat, humus, muck, and decomposed manure, separately or with other articles. This includes movement of articles listed above that may be associated with cut/waste, ditch pulling, and shoulder cutting.
2. Plants with roots including grass sod.
3. Plant crowns and roots.
4. Bulbs, corms, rhizomes, and tubers of ornamental plants.
5. Hay, straw, fodder, and plant litter of any kind.
6. Clearing and grubbing debris.
7. Used agricultural cultivating and harvesting equipment.
8. Used earth-moving equipment.
9. Any other products, articles, or means of conveyance, of any character, if determined by an inspector to present a hazard of spreading imported fire ant, gypsy moth, witchweed, emerald ash borer, or other noxious weeds.

MINIMUM WAGES:

(7-21-09)

Z-5

FEDERAL: The Fair Labor Standards Act provides that with certain exceptions every employer shall pay wages at the rate of not less than SEVEN DOLLARS AND TWENTY FIVE CENTS (\$7.25) per hour.

STATE: The North Carolina Minimum Wage Act provides that every employer shall pay to each of his employees, wages at a rate of not less than SEVEN DOLLARS AND TWENTY FIVE CENTS (\$7.25) per hour.

The minimum wage paid to all skilled labor employed on this contract shall be SEVEN DOLLARS AND TWENTY FIVE CENTS (\$7.25) per hour.

The minimum wage paid to all intermediate labor employed on this contract shall be SEVEN DOLLARS AND TWENTY FIVE CENTS (\$7.25) per hour.

The minimum wage paid to all unskilled labor on this contract shall be SEVEN DOLLARS AND TWENTY FIVE CENTS (\$7.25) per hour.

This determination of the intent of the application of this act to the contract on this project is the responsibility of the Contractor.

The Contractor shall have no claim against the Department of Transportation for any changes in the minimum wage laws, Federal or State. It is the responsibility of the Contractor to keep fully informed of all Federal and State Laws affecting his contract.

AWARD OF CONTRACT:

(6-28-77) (Rev 2/16/2016)

Z-6

“The North Carolina Department of Transportation, in accordance with the provisions of *Title VI of the Civil Rights Act of 1964* (78 Stat. 252) and the Regulations of the Department of Transportation (*49 C.F.R., Part 21*), issued pursuant to such act, hereby notifies all bidders that it will affirmatively insure that the contract entered into pursuant to this advertisement will be awarded to the lowest responsible bidder without discrimination on the ground of race, color, or national origin”.

TITLE VI AND NONDISCRIMINATION**I. Title VI Assurance**

During the performance of this contract, the contractor, for itself, its assignees and successors in interest (hereinafter referred to as the "contractor") agrees as follows:

(1) Compliance with Regulations: The contractor shall comply with the Regulation relative to nondiscrimination in Federally-assisted programs of the Department of Transportation (hereinafter, "DOT") Title 49, Code of Federal Regulations, Part 21, as they may be amended from time to time, (hereinafter referred to as the Regulations), which are herein incorporated by reference and made a part of this contract.

(2) Nondiscrimination: The Contractor, with regard to the work performed by it during the contract, shall not discriminate on the grounds of race, color, or national origin in the selection and retention of subcontractors, including procurements of materials and leases of equipment. The contractor shall not participate either directly or indirectly in the discrimination prohibited by section 21.5 of the Regulations, including employment practices when the contract covers a program set forth in Appendix B of the Regulations.

(3) Solicitations for Subcontractors, Including Procurements of Materials and Equipment: In all solicitations either by competitive bidding or negotiation made by the contractor for work to be performed under a subcontract, including procurements of materials or leases of equipment, each potential subcontractor or supplier shall be notified by the contractor of the contractor's obligations under this contract and the Regulations relative to nondiscrimination on the grounds of race, color, or national origin.

(4) Information and Reports: The contractor shall provide all information and reports required by the Regulations or directives issued pursuant thereto, and shall permit access to its books, records, accounts, other sources of information, and its facilities as may be determined by the North Carolina Department of Transportation (NCDOT) or the Federal Highway Administration (FHWA) to be pertinent to ascertain compliance with such Regulations, orders and instructions. Where any information required of a contractor is in the exclusive possession of another who fails or refuses to furnish this information the

contractor shall so certify to the NCDOT, or the FHWA as appropriate, and shall set forth what efforts it has made to obtain the information.

(5) Sanctions for Noncompliance: In the event of the contractor's noncompliance with the nondiscrimination provisions of this contract, the NCDOT shall impose such contract sanctions as it or the FHWA may determine to be appropriate, including, but not limited to:

- (a) Withholding of payments to the contractor under the contract until the contractor complies, and/or
- (b) Cancellation, termination or suspension of the contract, in whole or in part.

(6) Incorporation of Provisions: The contractor shall include the provisions of paragraphs (1) through (6) in every subcontract, including procurements of materials and leases of equipment, unless exempt by the Regulations, or directives issued pursuant thereto.

The contractor shall take such action with respect to any subcontractor procurement as the NCDOT or the FHWA may direct as a means of enforcing such provisions including sanctions for noncompliance: provided, however, that, in the event a contractor becomes involved in, or is threatened with, litigation with a subcontractor or supplier as a result of such direction, the contractor may request the NCDOT to enter into such litigation to protect the interests of the NCDOT, and, in addition, the contractor may request the United States to enter into such litigation to protect the interests of the United States.

II. Title VI Nondiscrimination Program

Title VI of the 1964 Civil Rights Act, 42 U.S.C. 2000d, provides that: "No person in the United States shall, on the grounds of race, color, or national origin, be excluded from participation in, be denied the benefits of, or be subjected to discrimination under any program or activity receiving Federal financial assistance." The broader application of nondiscrimination law is found in other statutes, executive orders, and regulations (see Section III, Pertinent Nondiscrimination Authorities), which provide additional protections based on age, sex, disability and religion. In addition, the 1987 Civil Rights Restoration Act extends nondiscrimination coverage to all programs and activities of federal-aid recipients and contractors, including those that are not federally-funded.

Nondiscrimination Assurance

The North Carolina Department of Transportation (NCDOT) hereby gives assurance that no person shall on the ground of race, color, national origin, sex, age, and disability, be excluded from participation in, be denied the benefits of, or be otherwise subjected to discrimination under any program or activity conducted by the recipient, as provided by Title VI of the Civil Rights Act of 1964, the Civil Rights Restoration Act of 1987, and any other related Civil Rights authorities, whether those programs and activities are federally funded or not.

Obligation

During the performance of this contract, the Contractor and its subcontractors are responsible for complying with NCDOT's Title VI Program. The Contractor must ensure that NCDOT's Notice of Nondiscrimination is posted in conspicuous locations accessible to all employees and subcontractors on the jobsite, along with the Contractor's own Equal Employment Opportunity (EEO) Policy Statement. The Contractor shall physically incorporate this "**TITLE VI AND NONDISCRIMINATION**" language, in its entirety, into all its subcontracts on federally-assisted and state-funded NCDOT-owned projects, and ensure its inclusion by subcontractors into all subsequent lower tier subcontracts. The Contractor and its subcontractors shall also physically incorporate the **FHWA-1273**, in its entirety, into all subcontracts and subsequent lower tier subcontracts on Federal-aid highway construction contracts only. The Contractor is also responsible for making its subcontractors aware of NCDOT's Discrimination Complaints Process, as follows:

FILING OF COMPLAINTS

1. **Applicability** – These complaint procedures apply to the beneficiaries of the NCDOT's programs, activities, and services, including, but not limited to, members of the public, contractors, subcontractors, consultants, and other sub-recipients of federal and state funds.
2. **Eligibility** – Any person or class of persons who believes he/she has been subjected to discrimination or retaliation prohibited by any of the Civil Rights authorities, based upon race, color, sex, age, national origin, or disability, may file a written complaint with NCDOT's Civil Rights office. The law prohibits intimidation or retaliation of any sort. The complaint may be filed by the affected individual or a representative, and must be in writing.
3. **Time Limits and Filing Options** – A complaint must be filed no later than 180 calendar days after the following:
 - The date of the alleged act of discrimination; or
 - The date when the person(s) became aware of the alleged discrimination; or
 - Where there has been a continuing course of conduct, the date on which that conduct was discontinued or the latest instance of the conduct.

Title VI and other discrimination complaints may be submitted to the following entities:

- **North Carolina Department of Transportation**, Office of Equal Opportunity & Workforce Services (EOWS), External Civil Rights Section, 1511 Mail Service Center, Raleigh, NC 27699-1511; 919-508-1808 or toll free 800-522-0453
- **US Department of Transportation**, Departmental Office of Civil Rights, External Civil Rights Programs Division, 1200 New Jersey Avenue, SE, Washington, DC 20590; 202-366-4070

Federal Highway Administration, North Carolina Division Office, 310 New Bern Avenue, Suite 410, Raleigh, NC 27601, 919-747-7010

Federal Highway Administration, Office of Civil Rights, 1200 New Jersey Avenue, SE, 8th Floor, E81-314, Washington, DC 20590, 202-366-0693 / 366-0752

Federal Transit Administration, Office of Civil Rights, ATTN: Title VI Program Coordinator, East Bldg. 5th Floor – TCR, 1200 New Jersey Avenue, SE, Washington, DC 20590

Federal Aviation Administration, Office of Civil Rights, 800 Independence Avenue, SW, Washington, DC 20591, 202-267-3258

- **US Department of Justice**, Special Litigation Section, Civil Rights Division, 950 Pennsylvania Avenue, NW, Washington, DC 20530, 202-514-6255 or toll free 877-218-5228

4. Format for Complaints – Complaints must be in **writing** and **signed** by the complainant(s) or a representative and include the complainant’s name, address, and telephone number. Complaints received by fax or e-mail will be acknowledged and processed. Allegations received by telephone will be reduced to writing and provided to the complainant for confirmation or revision before processing. Complaints will be accepted in other languages including Braille.

5. Discrimination Complaint Form – Contact NCDOT EOWS at the phone number above to receive a full copy of the Discrimination Complaint Form and procedures.

6. Complaint Basis – Allegations must be based on issues involving race, color, national origin, sex, age, or disability. The term “basis” refers to the complainant’s membership in a protected group category. Contact this office to receive a Discrimination Complaint Form.

Protected Categories	Definition	Examples	Applicable Statutes and Regulations	
			FHWA	FTA
Race	An individual belonging to one of the accepted racial groups; or the perception, based usually on physical characteristics that a person is a member of a racial group	Black/African American, Hispanic/Latino, Asian, American Indian/Alaska Native, Native Hawaiian/Pacific Islander, White	Title VI of the Civil Rights Act of 1964; 49 CFR Part 21; 23 CFR 200	Title VI of the Civil Rights Act of 1964; 49 CFR Part 21; Circular 4702.1B
Color	Color of skin, including shade of skin within a racial group	Black, White, brown, yellow, etc.		
National Origin	Place of birth. Citizenship is not a factor. Discrimination based on language or a person’s accent is also covered.	Mexican, Cuban, Japanese, Vietnamese, Chinese		
Sex	Gender	Women and Men	1973 Federal-Aid Highway Act	Title IX of the Education Amendments of 1972
Age	Persons of any age	21 year old person	Age Discrimination Act of 1975	
Disability	Physical or mental impairment, permanent or temporary, or perceived.	Blind, alcoholic, para-amputee, epileptic, diabetic, arthritic	Section 504 of the Rehabilitation Act of 1973; Americans with Disabilities Act of 1990	

III. Pertinent Nondiscrimination Authorities

During the performance of this contract, the contractor, for itself, its assignees, and successors in interest agrees to comply with the following non-discrimination statutes and authorities, including, but not limited to:

- Title VI of the Civil Rights Act of 1964 (42 U.S.C. § 2000d *et seq.*, 78 stat. 252), (prohibits discrimination on the basis of race, color, national origin); and 49 CFR Part 21.
- The Uniform Relocation Assistance and Real Property Acquisition Policies Act of 1970, (42 U.S.C. § 4601), (prohibits unfair treatment of persons displaced or whose property has been acquired because of Federal or Federal-aid programs and projects);
- Federal-Aid Highway Act of 1973, (23 U.S.C. § 324 *et seq.*), (prohibits discrimination on the basis of sex);
- Section 504 of the Rehabilitation Act of 1973, (29 U.S.C. § 794 *et seq.*), as amended, (prohibits discrimination on the basis of disability); and 49 CFR Part 27;
- The Age Discrimination Act of 1975, as amended, (42 U.S.C. § 6101 *et seq.*), (prohibits discrimination on the basis of age);
- Airport and Airway Improvement Act of 1982, (49 USC § 471, Section 47123), as amended, (prohibits discrimination based on race, creed, color, national origin, or sex);
- The Civil Rights Restoration Act of 1987, (PL 100-209), (Broadened the scope, coverage and applicability of Title VI of the Civil Rights Act of 1964, The Age Discrimination Act of 1975 and Section 504 of the Rehabilitation Act of 1973, by expanding the definition of the terms “programs or activities” to include all of the programs or activities of the Federal-aid recipients, sub-recipients and contractors, whether such programs or activities are Federally funded or not);
- Titles II and III of the Americans with Disabilities Act, which prohibit discrimination on the basis of disability in the operation of public entities, public and private transportation systems, places of public accommodation, and certain testing entities (42 U.S.C. §§ 12131 – 12189) as implemented by Department of Transportation regulations at 49 C.F.R. parts 37 and 38;
- The Federal Aviation Administration’s Non-discrimination statute (49 U.S.C. § 47123) (prohibits discrimination on the basis of race, color, national origin, and sex);
- Executive Order 12898, Federal Actions to Address Environmental Justice in Minority Populations and Low-Income Populations, which ensures discrimination against minority populations by discouraging programs, policies, and activities with disproportionately high and adverse human health or environmental effects on minority and low-income populations;
- Executive Order 13166, Improving Access to Services for Persons with Limited English Proficiency, and resulting agency guidance, national origin discrimination includes discrimination because of limited English proficiency (LEP). To ensure compliance with Title VI, you must take reasonable steps to ensure that LEP persons have meaningful access to your programs (70 Fed. Reg. at 74087 to 74100);
- Title IX of the Education Amendments of 1972, as amended, which prohibits you from discriminating because of sex in education programs or activities (20 U.S.C. 1681 *et seq.*).
- Title VII of the Civil Rights Act of 1964 (42 U.S.C. § 2000e *et seq.*, Pub. L. 88-352), (prohibits employment discrimination on the basis of race, color, religion, sex, or national origin);
- 49 CFR Part 26, regulation to ensure nondiscrimination in the award and administration of DOT-assisted contracts in the Department's highway, transit, and airport financial assistance programs, as regards the use of Disadvantaged Business Enterprises (DBEs);
- Form FHWA-1273, “Required Contract Provisions,” a collection of contract provisions and proposal notices that are generally applicable to *all Federal-aid construction projects* and must be made a part of, and physically incorporated into, *all federally-assisted contracts*, as well as appropriate subcontracts and purchase orders, particularly Sections II (Nondiscrimination) and III (Nonsegregated Facilities).

ON-THE-JOB TRAINING:

(10-16-07) (Rev. 4-21-15)

Z-10

Description

The North Carolina Department of Transportation will administer a custom version of the Federal On-the-Job Training (OJT) Program, commonly referred to as the Alternate OJT Program. All contractors (existing and newcomers) will be automatically placed in the Alternate Program. Standard OJT requirements typically associated with individual projects will no longer be applied at the project level. Instead, these requirements will be applicable on an annual basis for each contractor administered by the OJT Program Manager.

On the Job Training shall meet the requirements of 23 CFR 230.107 (b), 23 USC – Section 140, this provision and the On-the-Job Training Program Manual.

The Alternate OJT Program will allow a contractor to train employees on Federal, State and privately funded projects located in North Carolina. However, priority shall be given to training employees on NCDOT Federal-Aid funded projects.

Minorities and Women

Developing, training and upgrading of minorities and women toward journeyman level status is a primary objective of this special training provision. Accordingly, the Contractor shall make every effort to enroll minority and women as trainees to the extent that such persons are available within a reasonable area of recruitment. This training commitment is not intended, and shall not be used, to discriminate against any applicant for training, whether a member of a minority group or not.

Assigning Training Goals

The Department, through the OJT Program Manager, will assign training goals for a calendar year based on the contractors' past three years' activity and the contractors' anticipated upcoming year's activity with the Department. At the beginning of each year, all contractors eligible will be contacted by the Department to determine the number of trainees that will be assigned for the upcoming calendar year. At that time the Contractor shall enter into an agreement with the Department to provide a self-imposed on-the-job training program for the calendar year. This agreement will include a specific number of annual training goals agreed to by both parties. The number of training assignments may range from 1 to 15 per contractor per calendar year. The Contractor shall sign an agreement to fulfill their annual goal for the year.\

Training Classifications

The Contractor shall provide on-the-job training aimed at developing full journeyman level workers in the construction craft/operator positions. Preference shall be given to providing training in the following skilled work classifications:

Equipment Operators	Office Engineers
Truck Drivers	Estimators
Carpenters	Iron / Reinforcing Steel Workers
Concrete Finishers	Mechanics
Pipe Layers	Welders

The Department has established common training classifications and their respective training requirements that may be used by the contractors. However, the classifications established are not all-inclusive. Where the training is oriented toward construction applications, training will be allowed in lower-level management positions such as office engineers and estimators. Contractors shall submit new classifications for specific job functions that their employees are performing. The Department will review and recommend for acceptance to FHWA the new classifications proposed by contractors, if applicable. New classifications shall meet the following requirements:

Proposed training classifications are reasonable and realistic based on the job skill classification needs, and

The number of training hours specified in the training classification is consistent with common practices and provides enough time for the trainee to obtain journeyman level status.

The Contractor may allow trainees to be trained by a subcontractor provided that the Contractor retains primary responsibility for meeting the training and this provision is made applicable to the subcontract. However, only the Contractor will receive credit towards the annual goal for the trainee.

Where feasible, 25 percent of apprentices or trainees in each occupation shall be in their first year of apprenticeship or training. The number of trainees shall be distributed among the work classifications on the basis of the contractor's needs and the availability of journeymen in the various classifications within a reasonable area of recruitment.

No employee shall be employed as a trainee in any classification in which they have successfully completed a training course leading to journeyman level status or in which they have been employed as a journeyman.

Records and Reports

The Contractor shall maintain enrollment, monthly and completion reports documenting company compliance under these contract documents. These documents and any other information as requested shall be submitted to the OJT Program Manager.

Upon completion and graduation of the program, the Contractor shall provide each trainee with a certification Certificate showing the type and length of training satisfactorily completed.

Trainee Interviews

All trainees enrolled in the program will receive an initial and Trainee/Post graduate interview conducted by the OJT program staff.

Trainee Wages

Contractors shall compensate trainees on a graduating pay scale based upon a percentage of the prevailing minimum journeyman wages (Davis-Bacon Act). Minimum pay shall be as follows:

60 percent	of the journeyman wage for the first half of the training period
75 percent	of the journeyman wage for the third quarter of the training period
90 percent	of the journeyman wage for the last quarter of the training period

In no instance shall a trainee be paid less than the local minimum wage. The Contractor shall adhere to the minimum hourly wage rate that will satisfy both the NC Department of Labor (NCDOL) and the Department.

Achieving or Failing to Meet Training Goals

The Contractor will be credited for each trainee employed by him on the contract work who is currently enrolled or becomes enrolled in an approved program and who receives training for at least 50 percent of the specific program requirement. Trainees will be allowed to be transferred between projects if required by the Contractor's scheduled workload to meet training goals.

If a contractor fails to attain their training assignments for the calendar year, they may be taken off the NCDOT's Bidders List.

Measurement and Payment

No compensation will be made for providing required training in accordance with these contract documents.

NAME CHANGE FOR NCDENR:

(1-19-16)

Z-11

Wherever in the 2012 Standard Specifications, Project Special Provisions, Standard Special Provisions, Permits or Plans that reference is made to "NCDENR" or "North Carolina Department of Environment and Natural Resources", replace with "NCDEQ" or North Carolina Department of Environmental Quality" respectively, as the case may be.

EXECUTION OF BID

NON-COLLUSION AFFIDAVIT, DEBARMENT CERTIFICATION AND GIFT BAN CERTIFICATION

CORPORATION

The person executing the bid, on behalf of the Bidder, being duly sworn, solemnly swears (or affirms) that neither he, nor any official, agent or employee of the bidder has entered into any agreement, participated in any collusion, or otherwise taken any action which is in restraint of free competitive bidding in connection with any bid or contract, that the bidder has not been convicted of violating *N.C.G.S. § 133-24* within the last three years, and that the Bidder intends to do the work with its own bonafide employees or subcontractors and is not bidding for the benefit of another contractor.

In addition, execution of this bid in the proper manner also constitutes the Bidder's certification of status under penalty of perjury under the laws of the United States in accordance with the Debarment Certification attached, provided that the Debarment Certification also includes any required statements concerning exceptions that are applicable.

N.C.G.S. § 133-32 and Executive Order 24 prohibit the offer to, or acceptance by, any State Employee of any gift from anyone with a contract with the State, or from any person seeking to do business with the State. By execution of any response in this procurement, you attest, for your entire organization and its employees or agents, that you are not aware that any such gift has been offered, accepted, or promised by any employees of your organization.

SIGNATURE OF CONTRACTOR

Full name of Corporation

Address as Prequalified

Attest

Secretary/Assistant Secretary
Select appropriate title

By

President/Vice President/Assistant Vice President
Select appropriate title

Print or type Signer's name

Print or type Signer's name

CORPORATE SEAL

AFFIDAVIT MUST BE NOTARIZED

Subscribed and sworn to before me this the
____ day of _____ 20__.

NOTARY SEAL

Signature of Notary Public

of _____ County

State of _____

My Commission Expires: _____

**EXECUTION OF BID
NON-COLLUSION AFFIDAVIT, DEBARMENT CERTIFICATION AND GIFT BAN CERTIFICATION
PARTNERSHIP**

The person executing the bid, on behalf of the Bidder, being duly sworn, solemnly swears (or affirms) that neither he, nor any official, agent or employee of the bidder has entered into any agreement, participated in any collusion, or otherwise taken any action which is in restraint of free competitive bidding in connection with any bid or contract, that the bidder has not been convicted of violating *N.C.G.S. § 133-24* within the last three years, and that the Bidder intends to do the work with its own bonafide employees or subcontractors and is not bidding for the benefit of another contractor.

In addition, execution of this bid in the proper manner also constitutes the Bidder's certification of status under penalty of perjury under the laws of the United States in accordance with the Debarment Certification attached, provided that the Debarment Certification also includes any required statements concerning exceptions that are applicable.

N.C.G.S. § 133-32 and Executive Order 24 prohibit the offer to, or acceptance by, any State Employee of any gift from anyone with a contract with the State, or from any person seeking to do business with the State. By execution of any response in this procurement, you attest, for your entire organization and its employees or agents, that you are not aware that any such gift has been offered, accepted, or promised by any employees of your organization.

SIGNATURE OF CONTRACTOR

_____ Full Name of Partnership

_____ Address as Prequalified

_____ By _____
Signature of Witness Signature of Partner

_____ Print or type Signer's name _____ Print or type Signer's name

AFFIDAVIT MUST BE NOTARIZED

Subscribed and sworn to before me this the
_____ day of _____, 20_____

NOTARY SEAL

Signature of Notary Public
Of _____ County
State of _____
My Commission Expires _____

**EXECUTION OF BID
 NON-COLLUSION AFFIDAVIT, DEBARMENT CERTIFICATION AND GIFT BAN CERTIFICATION
 LIMITED LIABILITY COMPANY**

The person executing the bid, on behalf of the Bidder, being duly sworn, solemnly swears (or affirms) that neither he, nor any official, agent or employee of the bidder has entered into any agreement, participated in any collusion, or otherwise taken any action which is in restraint of free competitive bidding in connection with any bid or contract, that the bidder has not been convicted of violating *N.C.G.S. § 133-24* within the last three years, and that the Bidder intends to do the work with its own bonafide employees or subcontractors and is not bidding for the benefit of another contractor.

In addition, execution of this bid in the proper manner also constitutes the Bidder's certification of status under penalty of perjury under the laws of the United States in accordance with the Debarment Certification attached, provided that the Debarment Certification also includes any required statements concerning exceptions that are applicable.

N.C.G.S. § 133-32 and Executive Order 24 prohibit the offer to, or acceptance by, any State Employee of any gift from anyone with a contract with the State, or from any person seeking to do business with the State. By execution of any response in this procurement, you attest, for your entire organization and its employees or agents, that you are not aware that any such gift has been offered, accepted, or promised by any employees of your organization.

SIGNATURE OF CONTRACTOR

_____ Full Name of Firm

_____ Address as Prequalified

_____ Signature of Witness

_____ Signature of Member/Manager/Authorized Agent
Select appropriate title

_____ Print or type Signer's name

_____ Print or type Signer's Name

AFFIDAVIT MUST BE NOTARIZED

Subscribed and sworn to before me this the
 ____ day of _____ 20__.

NOTARY SEAL

_____ Signature of Notary Public

of _____ County

State of _____

My Commission Expires: _____

**EXECUTION OF BID
NON-COLLUSION AFFIDAVIT, DEBARMENT CERTIFICATION AND GIFT BAN CERTIFICATION
JOINT VENTURE (2) or (3)**

The person executing the bid, on behalf of the Bidder, being duly sworn, solemnly swears (or affirms) that neither he, nor any official, agent or employee of the bidder has entered into any agreement, participated in any collusion, or otherwise taken any action which is in restraint of free competitive bidding in connection with any bid or contract, that the bidder has not been convicted of violating *N.C.G.S. § 133-24* within the last three years, and that the Bidder intends to do the work with its own bonafide employees or subcontractors and is not bidding for the benefit of another contractor.

In addition, execution of this bid in the proper manner also constitutes the Bidder's certification of status under penalty of perjury under the laws of the United States in accordance with the Debarment Certification attached, provided that the Debarment Certification also includes any required statements concerning exceptions that are applicable.

N.C.G.S. § 133-32 and Executive Order 24 prohibit the offer to, or acceptance by, any State Employee of any gift from anyone with a contract with the State, or from any person seeking to do business with the State. By execution of any response in this procurement, you attest, for your entire organization and its employees or agents, that you are not aware that any such gift has been offered, accepted, or promised by any employees of your organization.

SIGNATURE OF CONTRACTOR

Instructions: **2 Joint Venturers** Fill in lines (1), (2) and (3) and execute. **3 Joint Venturers** Fill in lines (1), (2), (3) and (4) and execute. On Line (1), fill in the name of the Joint Venture Company. On Line (2), fill in the name of one of the joint venturers and execute below in the appropriate manner. On Line (3), print or type the name of the other joint venturer and execute below in the appropriate manner. On Line (4), fill in the name of the third joint venturer, if applicable and execute below in the appropriate manner.

(1) _____
Name of Joint Venture

(2) _____
Name of Contractor

Address as Prequalified

_____ Signature of Witness or Attest	By	_____ Signature of Contractor
_____ Print or type Signer's name		_____ Print or type Signer's name

If Corporation, affix Corporate Seal and

(3) _____
Name of Contractor

Address as Prequalified

_____ Signature of Witness or Attest	By	_____ Signature of Contractor
_____ Print or type Signer's name		_____ Print or type Signer's name

If Corporation, affix Corporate Seal and

(4) _____
Name of Contractor (for 3 Joint Venture only)

Address as Prequalified

_____ Signature of Witness or Attest	By	_____ Signature of Contractor
_____ Print or type Signer's name		_____ Print or type Signer's name

If Corporation, affix Corporate Seal

NOTARY SEAL

Affidavit must be notarized for Line (2)

Subscribed and sworn to before me this _____ day of _____ 20__

Signature of Notary Public
of _____ County
State of _____
My Commission Expires: _____

NOTARY SEAL

Affidavit must be notarized for Line (3)

Subscribed and sworn to before me this _____ day of _____ 20__

Signature of Notary Public
of _____ County
State of _____
My Commission Expires: _____

NOTARY SEAL

Affidavit must be notarized for Line (4)

Subscribed and sworn to before me this _____ day of _____ 20__

Signature of Notary Public
of _____ County
State of _____
My Commission Expires: _____

**EXECUTION OF BID
NON-COLLUSION AFFIDAVIT, DEBARMENT CERTIFICATION AND GIFT BAN CERTIFICATION**

INDIVIDUAL DOING BUSINESS UNDER A FIRM NAME

The person executing the bid, on behalf of the Bidder, being duly sworn, solemnly swears (or affirms) that neither he, nor any official, agent or employee of the bidder has entered into any agreement, participated in any collusion, or otherwise taken any action which is in restraint of free competitive bidding in connection with any bid or contract, that the bidder has not been convicted of violating *N.C.G.S. § 133-24* within the last three years, and that the Bidder intends to do the work with its own bonafide employees or subcontractors and is not bidding for the benefit of another contractor.

In addition, execution of this bid in the proper manner also constitutes the Bidder's certification of status under penalty of perjury under the laws of the United States in accordance with the Debarment Certification attached, provided that the Debarment Certification also includes any required statements concerning exceptions that are applicable.

N.C.G.S. § 133-32 and Executive Order 24 prohibit the offer to, or acceptance by, any State Employee of any gift from anyone with a contract with the State, or from any person seeking to do business with the State. By execution of any response in this procurement, you attest, for your entire organization and its employees or agents, that you are not aware that any such gift has been offered, accepted, or promised by any employees of your organization.

SIGNATURE OF CONTRACTOR

Name of Contractor

_____ Individual name

Trading and doing business as

_____ Full name of Firm

Signature of Witness

Signature of Contractor, Individually

Print or type Signer's name

Print or type Signer's name

AFFIDAVIT MUST BE NOTARIZED

Subscribed and sworn to before me this the

NOTARY SEAL

_____ day of _____ 20__.

Signature of Notary Public

of _____ County

State of _____

My Commission Expires: _____

**EXECUTION OF BID
NON-COLLUSION AFFIDAVIT, DEBARMENT CERTIFICATION AND GIFT BAN CERTIFICATION**

INDIVIDUAL DOING BUSINESS IN HIS OWN NAME

The person executing the bid, on behalf of the Bidder, being duly sworn, solemnly swears (or affirms) that neither he, nor any official, agent or employee of the bidder has entered into any agreement, participated in any collusion, or otherwise taken any action which is in restraint of free competitive bidding in connection with any bid or contract, that the bidder has not been convicted of violating *N.C.G.S. § 133-24* within the last three years, and that the Bidder intends to do the work with its own bonafide employees or subcontractors and is not bidding for the benefit of another contractor.

In addition, execution of this bid in the proper manner also constitutes the Bidder's certification of status under penalty of perjury under the laws of the United States in accordance with the Debarment Certification attached, provided that the Debarment Certification also includes any required statements concerning exceptions that are applicable.

N.C.G.S. § 133-32 and Executive Order 24 prohibit the offer to, or acceptance by, any State Employee of any gift from anyone with a contract with the State, or from any person seeking to do business with the State. By execution of any response in this procurement, you attest, for your entire organization and its employees or agents, that you are not aware that any such gift has been offered, accepted, or promised by any employees of your organization.

SIGNATURE OF CONTRACTOR

Name of Contractor _____
Print or type Individual name

Address as Prequalified

Signature of Contractor, Individually

Print or type Signer's Name

Signature of Witness

Print or type Signer's name

AFFIDAVIT MUST BE NOTARIZED

Subscribed and sworn to before me this the
____ day of _____ 20__.

NOTARY SEAL

Signature of Notary Public

of _____ County

State of _____

My Commission Expires: _____

DEBARMENT CERTIFICATION

Conditions for certification:

1. The prequalified bidder shall provide immediate written notice to the Department if at any time the bidder learns that his certification was erroneous when he submitted his debarment certification or explanation filed with the Department, or has become erroneous because of changed circumstances.
2. The terms *covered transaction, debarred, suspended, ineligible, lower tier covered transaction, participant, person, primary covered transaction, principal, proposal, and voluntarily excluded*, as used in this provision, have the meanings set out in the Definitions and Coverage sections of the rules implementing Executive Order 12549. A copy of the Federal Rules requiring this certification and detailing the definitions and coverages may be obtained from the Contract Officer of the Department.
3. The prequalified bidder agrees by submitting this form that he will not knowingly enter into any lower tier covered transaction with a person who is debarred, suspended, declared ineligible, or voluntarily excluded from participation in NCDOT contracts, unless authorized by the Department.
4. For Federal Aid projects, the prequalified bidder further agrees that by submitting this form he will include the Federal-Aid Provision titled *Required Contract Provisions Federal-Aid Construction Contract (Form FHWA PR 1273)* provided by the Department, without subsequent modification, in all lower tier covered transactions.
5. The prequalified bidder may rely upon a certification of a participant in a lower tier covered transaction that he is not debarred, suspended, ineligible, or voluntarily excluded from the covered transaction, unless he knows that the certification is erroneous. The bidder may decide the method and frequency by which he will determine the eligibility of his subcontractors.
6. Nothing contained in the foregoing shall be construed to require establishment of a system of records in order to render in good faith the certification required by this provision. The knowledge and information of a participant is not required to exceed that which is normally possessed by a prudent person in the ordinary course of business dealings.
7. Except as authorized in paragraph 6 herein, the Department may terminate any contract if the bidder knowingly enters into a lower tier covered transaction with a person who is suspended, debarred, ineligible, or voluntarily excluded from participation in this transaction, in addition to other remedies available by the Federal Government.

DEBARMENT CERTIFICATION

The prequalified bidder certifies to the best of his knowledge and belief, that he and his principals:

- a. Are not presently debarred, suspended, proposed for debarment, declared ineligible, or voluntarily excluded from covered transactions by any Federal department or agency;
- b. Have not within a three-year period preceding this proposal been convicted of or had a civil judgment rendered against them for commission of fraud or a criminal offense in connection with obtaining, attempting to obtain, or performing a public (Federal, State or local) transaction or contract under a public transaction; violation of Federal or State antitrust statutes or commission of embezzlement, theft, forgery, bribery, falsification or destruction of records; making false statements; or receiving stolen property;
- c. Are not presently indicted for or otherwise criminally or civilly charged by a governmental entity (Federal, State or local) with commission of any of the offenses enumerated in paragraph b. of this certification; and
- d. Have not within a three-year period preceding this proposal had one or more public transactions (Federal, State or local) terminated for cause or default.
- e. Will submit a revised Debarment Certification immediately if his status changes and will show in his bid proposal an explanation for the change in status.

If the prequalified bidder cannot certify that he is not debarred, he shall provide an explanation with this submittal. An explanation will not necessarily result in denial of participation in a contract.

Failure to submit a non-collusion affidavit and debarment certification will result in the prequalified bidder's bid being considered non-responsive.

Check here if an explanation is attached to this certification.

**North Carolina Department of Transportation
CONTRACT BID FORM**

CONTRACT NO.: D6D2.SBE.001
PROJECT NUMBER: 6.102611, 6.202611, 6.202621, 6.102631, 6.104311, 6.204311, 6.204321, 6.104331
COUNTY: Cumberland & Harnett
DESCRIPTION: Misc. Concrete Construction
BID DATE: January 18, 2017

LINE	ITEM #	SECT	DESCRIPTION	QTY	UNIT	UNIT PRICE	AMOUNT BID
10	0001020000-N	SP	Emergency Call Back Mobilization	2	EA		
20	0036000000-E	SP	Undercut Excavation	10	CY		
30	0106000000-E	230	Borrow Excavation	10	CY		
40	0156000000-E	SP	Removal of Existing Asphalt Pavement	50	SY		
50	0170000000-E	SP	Removal of Existing Concrete Pavement	100	SY		
60	1121000000-E	SP	Aggregate Base Course	20	Ton		
70	2535000000-E	SP	8" x 12" or 18" Concrete Curb, Std. 846.01	5	LF		
80	2535000000-E	SP	9" x 12" or 18" Concrete Curb, Std. 846.01	5	LF		
90	2535000000-E	SP	8" x 6" Concrete Median Curb, Std. 846.01	5	LF		
100	2542000000-E	SP	1' - 6" Concrete Curb & Gutter, Std. 846.01	5	LF		
110	2549000000-E	SP	2' - 6" Concrete Curb and Gutter, Std. 846.01	300	LF		
120	2556000000-E	SP	Concrete Shoulder Berm Gutter, Std. 846.01	20	LF		
130	2577000000-E	SP	Concrete Expressway Gutter, Std. 846.01	20	LF		
140	2580000000-E	SP	Concrete Valley Gutter, Std. 846.01	20	LF		
150	2591000000-E	SP	4" Concrete Sidewalk, Std. 848.01	75	SY		
160	2605000000-E	SP	Concrete Curb Ramp, Std. 848.05	5	EA		
170	2612000000-E	848	6" Concrete Driveway Turnout	75	SY		
180	2612000000-E	848	6" Concrete Driveway Apron	100	SY		
190	2619000000-E	SP	4" Concrete Paved Ditch, Std. 850.01	20	SY		

200	2647000000-E	SP	5" Monolithic Concrete Island (Surface Mounted), Std. 852.01	50	SY		
210	2655000000-E	SP	5" Monolithic Concrete Island (Keyed In), Std. 852.01	50	SY		
220	4422000000-N	1120	Changeable Message Board (CMB)	5	EA		
230	4480000000-N	1165	Truck Mounted Impact Attenuator (TMIA)	5	EA		
240	4600000000-N	SP	Traffic Control – Single Lane Closure	10	EA		
250	4600000000-N	SP	Traffic Control – Multi-Lane Closure	5	EA		
260	5270000000-N	SP	Portable Light Plant	2	EA		

TOTAL BID FOR PROJECT: _____

CONTRACTOR _____

ADDRESS _____

Federal Identification Number _____ Contractors License Number _____

Authorized Agent _____ Title _____

Signature _____ Date _____

Witness _____ Title _____

Signature _____ Date _____

Point of Contact for Post Bid Inquiries (e.g., Letters of Intent, Insurance, Bonds, Contract Execution, etc.):

Name _____

Email _____

Phone _____

THIS SECTION TO BE COMPLETED BY NORTH CAROLINA DEPARTMENT OF TRANSPORTATION

This bid has been reviewed in accordance with Article 103-1 of the current edition of the **Standard Specifications for Roads and Structures**.

_____ Division Proposals Engineer

_____ Date

EXECUTION OF CONTRACT

Contract No: D6D2.SBE.001

County: Cumberland & Harnett

ACCEPTED BY THE DEPARTMENT

Proposals Engineer

Date

EXECUTION OF CONTRACT AND BONDS
APPROVED AS TO FORM:

Division Engineer

Date

Signature Sheet (Bid) - ACCEPTANCE SHEET