

PAVEMENT SCHEDULE	
C1	1½" ASPHALT CONCRETE SURFACE COURSE, TYPE SF9.5A, AT AN AVERAGE RATE OF 165 LBS. PER SQ. YD.
C2	1½" ASPHALT CONCRETE SURFACE COURSE, TYPE S9.5B, AT AN AVERAGE RATE OF 168 LBS. PER SQ. YD.
E1	5" ASPHALT CONCRETE BASE COURSE, TYPE B25.0B, AT AN AVERAGE RATE OF 570 LBS. PER SQ. YD.
T	AGGREGATE SHOULDER BORROW
U	EXISTING ASPHALT

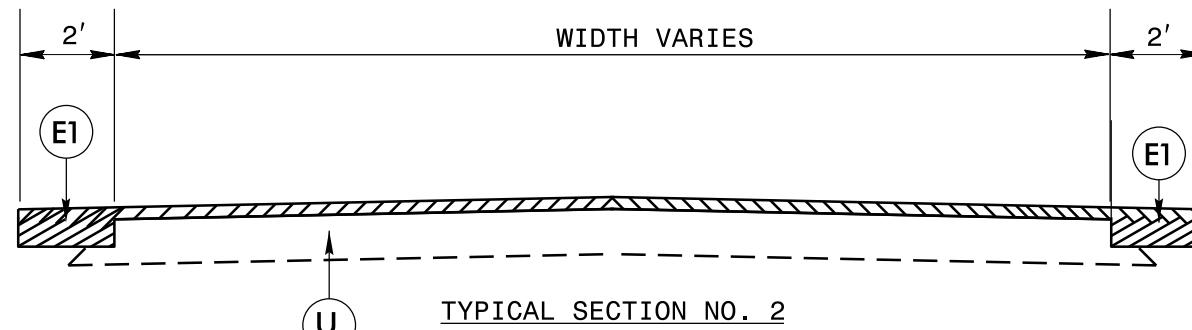

*WIDEN 2' ONLY IN BETWEEN THE EXISTING WIDENING.

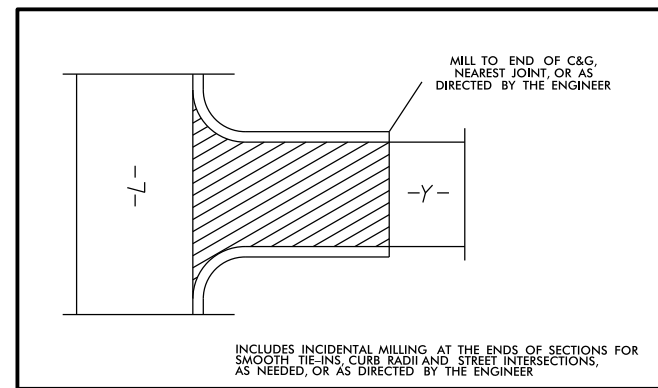
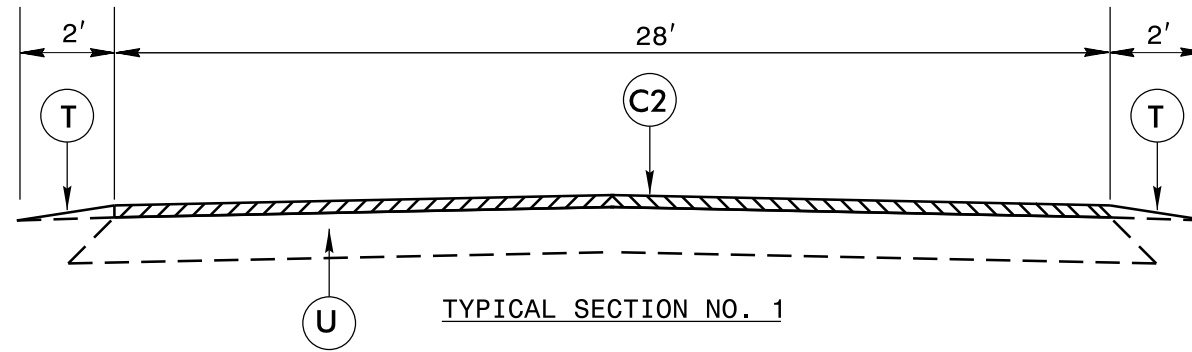
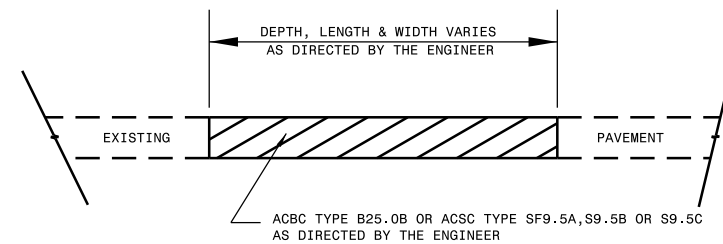
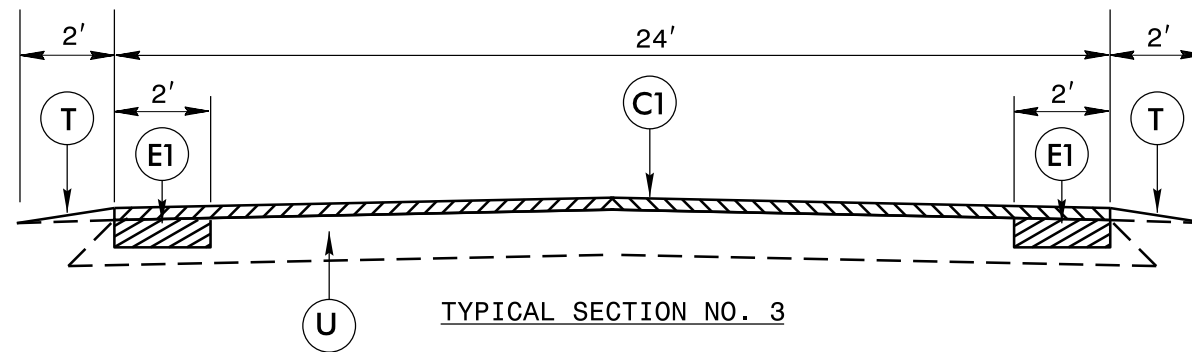

PATCHING EXISTING PAVEMENT
PATCHING TO BE PERFORMED PRIOR TO MILL AND FILL OPERATION

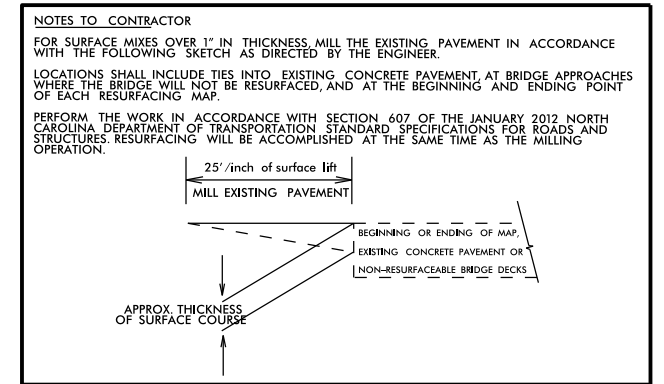

PROJECT NO.	SHEET NO.	TOTAL NO.
6CR.10261.82, 6CR.20431.82		

SUMMARY OF QUANTITIES

PROJECT	COUNTY	MAP	ROUTE	DESCRIPTION	TYP	LANES	LANE TYPE	FINAL SURFACE TESTING REQUIRED	WARM MIX ASPHALT REQUIRED	LENGTH MI	WIDTH FT	AGGREGATE SHOULDER BORROW	INCIDENTAL STONE BASE	SHOULDER RECONSTRUCTION	INCIDENTAL MILLING	BASE COURSE, B25.0B	SURFACE COURSE, S9.5B	SURFACE COURSE, SF9.5A	ASPHALT BINDER FOR PLANT MIX	PATCHING EXISTING PAVEMENT	ADJ. OF MANHOLES	ADJ. OF METER OR VALVE BOX
NO		NO			NO																	
6CR.10261.82	Cumberland	1	US HWY 401	FROM: PVMT JNT AT SR 1608 MP 23.27 TO HARNETT COUNTY MP 27.72	1	2	2WU	NO	NO	4.45	28	548	107	8.90	486		7,151		429		1	1
		TOTAL FOR MAP NO. 1								4.45		548	107	8.90	486		7,151		429		1	1
		TOTAL FOR PROJ NO. 6CR.10261.82								4.45		548	107	8.90	486		7,151		429		1	1
6CR.20431.82	Harnett	2	SR 1403	FROM: WAKE COUNTY MP 0.00 TO: US HWY 401 MP 11.07	2	2	2WU	NO	NO	7.18	4					4,802			211			
		TOTAL FOR MAP NO. 2								7.18						4,802			211			
6CR.20431.82	Harnett	3	SR 1415	FROM US HWY 401 MP 2.54 TO NC HWY 55 MP 7.86	3	2	2WU	NO	NO	5.32	20	655	128		764	3,558		6,316	580	20		
		TOTAL FOR MAP NO. 3								5.32		655	128		764	3,558		6,316	580	20		
		TOTAL FOR PROJ NO. 6CR.20431.82								12.5		655	128		764	8,360		6,316	791	20		
GRAND TOTAL												1,203	235	8.90	1,250	8,360	7,151	6,316	1,220	20	1	1

