

**This electronic collection of documents is provided
for the convenience of the user
and is Not a Certified Document –**

**The documents contained herein were originally issued
and sealed by the individuals whose names and license
numbers appear on each page, on the dates appearing
with their signature on that page.**

**This file or an individual page
shall not be considered a certified document.**

STATE	STATE PROJECT REFERENCE NO.	SHEET NO.	TOTAL SHEETS
N.C.	R-5013	1	
STATE PROJ. NO.	F.A. PROJ. NO.	DESCRIPTION	
41160.1.1		PE	
41160.2.1		ROW/UTIL	
41160.3.1		CONST	

STATE OF NORTH CAROLINA
DIVISION OF HIGHWAYS

COLUMBUS COUNTY

LOCATION: US 701/NC 410 (JAMES B WHITE HIGHWAY/EAST FIFTH STREET) AT NC 410 (JOE BROWN HIGHWAY)

TYPE OF WORK: GRADING, PAVING, DRAINAGE, SIGNING, AND PAVEMENT MARKING

FINAL PLANS

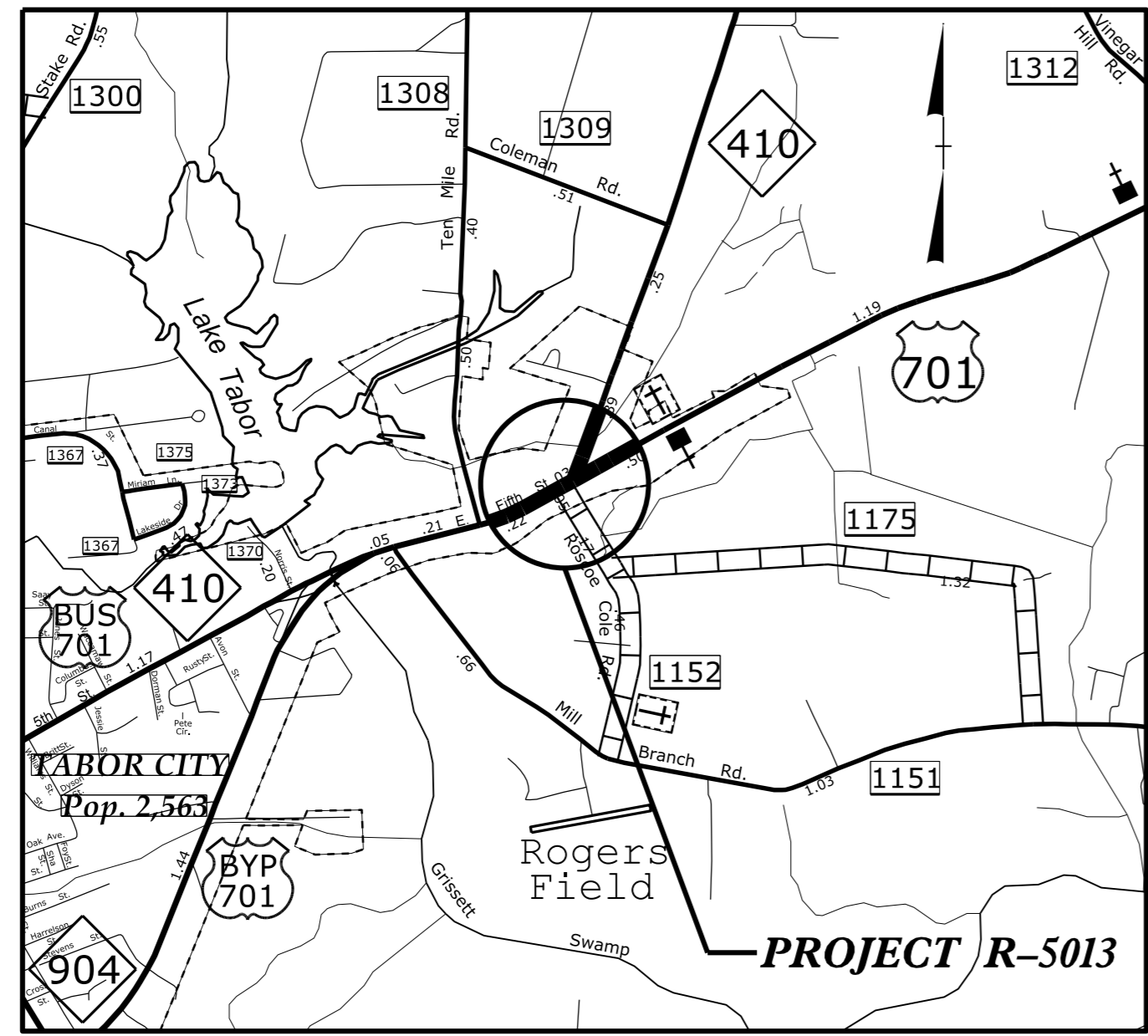
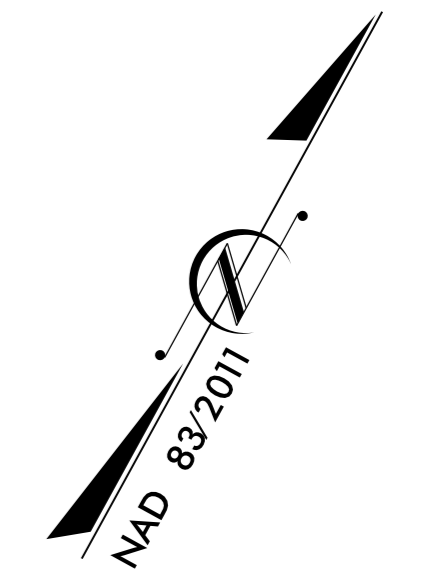

VICINITY MAP N.T.S.

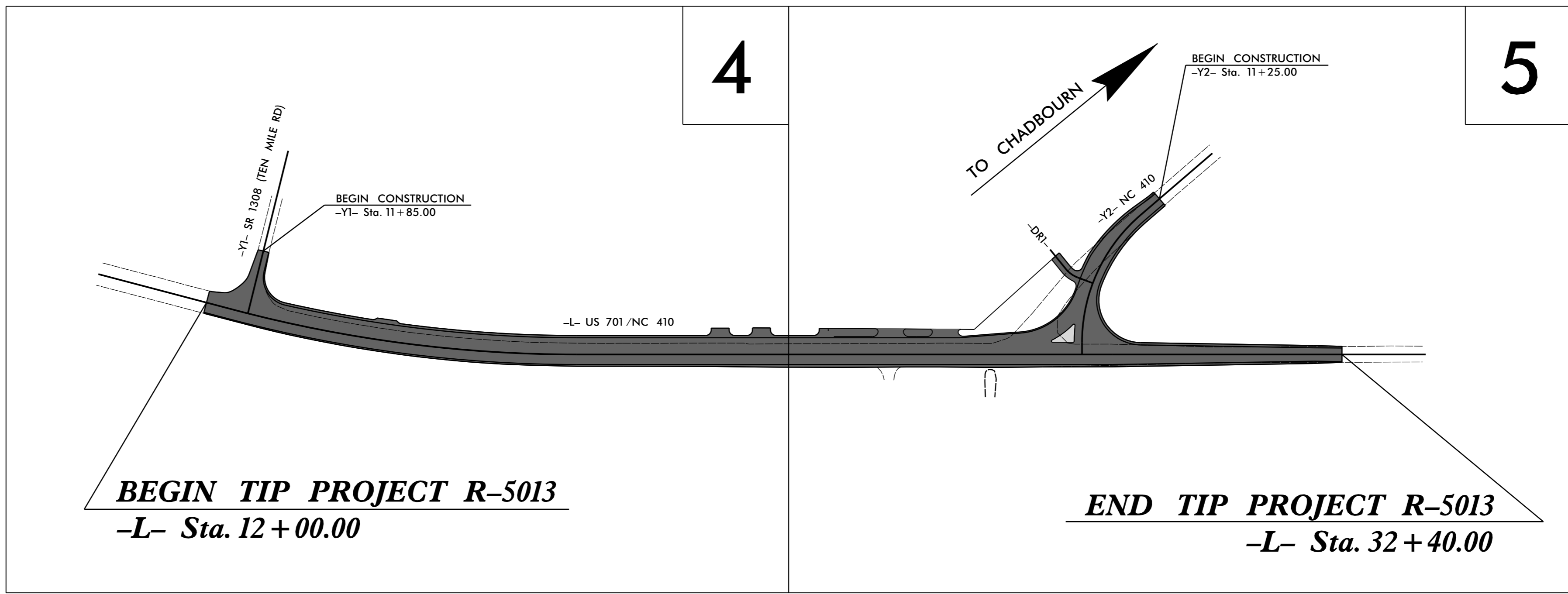

TIP PROJECT: R-5013

CONTRACT: DF00267

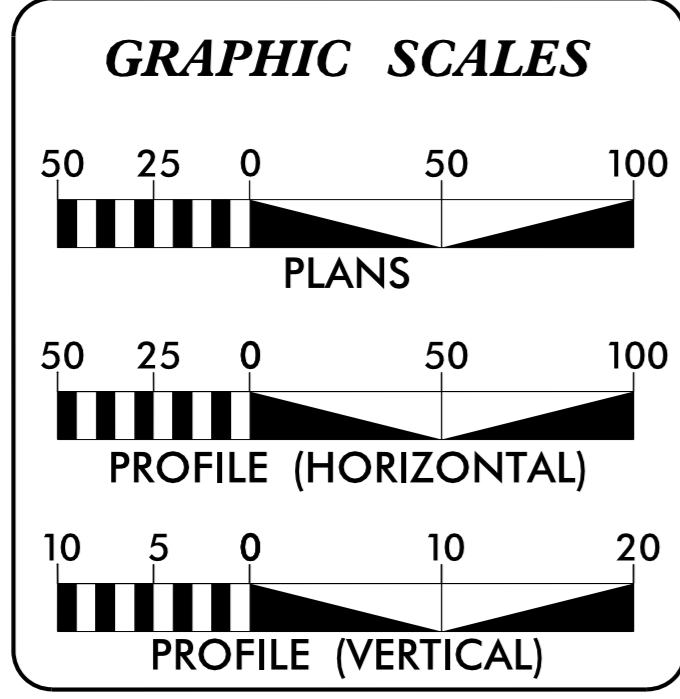

DESIGN DATA

ADT 2015 = 13,000
ADT 2045 = 24,500
D = 50 %
T = 5 % *
* TTST = 3% DUAL = 2%
V = 60 MPH
FUNC CLASS = ARTERIAL

PROJECT LENGTH

TOTAL LENGTH OF TIP PROJECT R-5013 = 0.386 MI

Prepared in the Office of:
DIVISION OF HIGHWAYS
431 Transportation Dr., Fayetteville NC, 28301

2018 STANDARD SPECIFICATIONS	
RIGHT OF WAY DATE: JUNE 29, 2018	JOHN GAUTHIER PROJECT ENGINEER
LETTING DATE: JUNE 19, 2019	ALEX HENDERSON PROJECT DESIGN ENGINEER

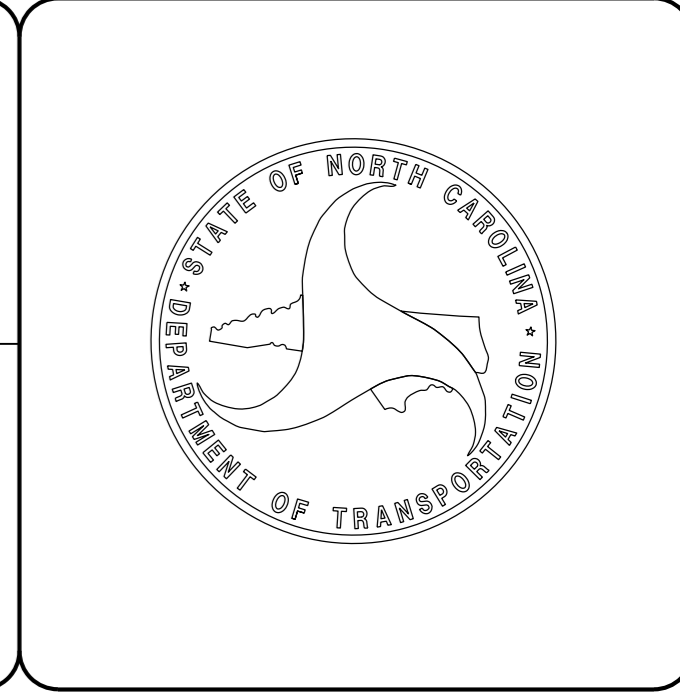

09/08/09
29-MAY-2019 09:33
H:\DDC\Projects\NR-5013 US 701 at NC 410\Roadway\Proj\NR-5013_Rdy_Tsh.dgn
\$\$\$\$\$USERNAME\$\$\$\$\$

STATE OF NORTH CAROLINA, DIVISION OF HIGHWAYS CONVENTIONAL PLAN SHEET SYMBOLS

BOUNDARIES AND PROPERTY:

State Line	-----
County Line	-----
Township Line	-----
City Line	-----
Reservation Line	-----
Property Line	-----
Existing Iron Pin	○ EIP
Computed Property Corner	----->
Property Monument	□ EDM
Parcel/Sequence Number	⑫③
Existing Fence Line	-x-x-x-
Proposed Woven Wire Fence	○
Proposed Chain Link Fence	□
Proposed Barbed Wire Fence	◇
Existing Wetland Boundary	----- WLB
Proposed Wetland Boundary	----- WLB
Existing Endangered Animal Boundary	----- EAB
Existing Endangered Plant Boundary	----- EPB
Existing Historic Property Boundary	----- HPB
Known Contamination Area: Soil	☠ S ☠
Potential Contamination Area: Soil	?? S ??
Known Contamination Area: Water	☠ W ☠
Potential Contamination Area: Water	?? W ??
Contaminated Site: Known or Potential	☠ ??

BUILDINGS AND OTHER CULTURE:

Gas Pump Vent or U/G Tank Cap	○
Sign	○ S
Well	○ W
Small Mine	✕
Foundation	□
Area Outline	□
Cemetery	□
Building	□
School	□
Church	□
Dam	□

HYDROLOGY:

Stream or Body of Water	-----
Hydro, Pool or Reservoir	□
Jurisdictional Stream	----- JS
Buffer Zone 1	----- BZ 1
Buffer Zone 2	----- BZ 2
Flow Arrow	←
Disappearing Stream	-----
Spring	○
Wetland	-----
Proposed Lateral, Tail, Head Ditch	-----
False Sump	▽

RAILROADS:

Standard Gauge	-----
RR Signal Milepost	○ MILEPOST 35
Switch	□ SWITCH
RR Abandoned	-----
RR Dismantled	-----

RIGHT OF WAY & PROJECT CONTROL:

Secondary Horiz and Vert Control Point	◆
Primary Horiz Control Point	○
Primary Horiz and Vert Control Point	◆
Exist Permanent Easement Pin and Cap	◇
New Permanent Easement Pin and Cap	◆
Vertical Benchmark	⊠
Existing Right of Way Marker	△
Existing Right of Way Line	-----
New Right of Way Line	-----
New Right of Way Line with Pin and Cap	-----
New Right of Way Line with Concrete or Granite RW Marker	-----
New Control of Access Line with Concrete C/A Marker	-----
Existing Control of Access	-----
New Control of Access	-----
Existing Easement Line	----- E
New Temporary Construction Easement	----- E
New Temporary Drainage Easement	----- TDE
New Permanent Drainage Easement	----- PDE
New Permanent Drainage / Utility Easement	----- DUE
New Permanent Utility Easement	----- PUE
New Temporary Utility Easement	----- TUE
New Aerial Utility Easement	----- AUE

ROADS AND RELATED FEATURES:

Existing Edge of Pavement	-----
Existing Curb	-----
Proposed Slope Stakes Cut	----- C
Proposed Slope Stakes Fill	----- F
Proposed Curb Ramp	----- CR
Existing Metal Guardrail	-----
Proposed Guardrail	-----
Existing Cable Guiderail	-----
Proposed Cable Guiderail	-----
Equality Symbol	⊕
Pavement Removal	⊠

VEGETATION:

Single Tree	☼
Single Shrub	☼

Note: Not to Scale

*S.U.E. = Subsurface Utility Engineering

Hedge	-----
Woods Line	-----
Orchard	-----
Vineyard	-----

EXISTING STRUCTURES:

MAJOR:	
Bridge, Tunnel or Box Culvert	----- CONC
Bridge Wing Wall, Head Wall and End Wall	----- CONC WW
MINOR:	
Head and End Wall	----- CONC HW
Pipe Culvert	-----
Footbridge	-----
Drainage Box: Catch Basin, DI or JB	□ CB
Paved Ditch Gutter	-----
Storm Sewer Manhole	○ S
Storm Sewer	----- S

UTILITIES:

POWER:	
Existing Power Pole	●
Proposed Power Pole	○
Existing Joint Use Pole	●
Proposed Joint Use Pole	○
Power Manhole	⊕
Power Line Tower	⊠
Power Transformer	⊠
U/G Power Cable Hand Hole	-----
H-Frame Pole	●
U/G Power Line LOS B (S.U.E.*)	----- P
U/G Power Line LOS C (S.U.E.*)	----- P
U/G Power Line LOS D (S.U.E.*)	----- P

TELEPHONE:

Existing Telephone Pole	●
Proposed Telephone Pole	○
Telephone Manhole	⊕
Telephone Pedestal	⊠
Telephone Cell Tower	⊠
U/G Telephone Cable Hand Hole	-----
U/G Telephone Cable LOS B (S.U.E.*)	----- T
U/G Telephone Cable LOS C (S.U.E.*)	----- T
U/G Telephone Cable LOS D (S.U.E.*)	----- T
U/G Telephone Conduit LOS B (S.U.E.*)	----- TC
U/G Telephone Conduit LOS C (S.U.E.*)	----- TC
U/G Telephone Conduit LOS D (S.U.E.*)	----- TC
U/G Fiber Optics Cable LOS B (S.U.E.*)	----- T FO
U/G Fiber Optics Cable LOS C (S.U.E.*)	----- T FO
U/G Fiber Optics Cable LOS D (S.U.E.*)	----- T FO

WATER:

Water Manhole	⊕
Water Meter	○
Water Valve	⊗
Water Hydrant	⊕
U/G Water Line LOS B (S.U.E.*)	----- W
U/G Water Line LOS C (S.U.E.*)	----- W
U/G Water Line LOS D (S.U.E.*)	----- W
Above Ground Water Line	----- A/G Water

TV:

TV Pedestal	⊠
TV Tower	⊗
U/G TV Cable Hand Hole	-----
U/G TV Cable LOS B (S.U.E.*)	----- TV
U/G TV Cable LOS C (S.U.E.*)	----- TV
U/G TV Cable LOS D (S.U.E.*)	----- TV
U/G Fiber Optic Cable LOS B (S.U.E.*)	----- TV FO
U/G Fiber Optic Cable LOS C (S.U.E.*)	----- TV FO
U/G Fiber Optic Cable LOS D (S.U.E.*)	----- TV FO

GAS:

Gas Valve	◇
Gas Meter	⊕
U/G Gas Line LOS B (S.U.E.*)	----- G
U/G Gas Line LOS C (S.U.E.*)	----- G
U/G Gas Line LOS D (S.U.E.*)	----- G
Above Ground Gas Line	----- A/G Gas

SANITARY SEWER:

Sanitary Sewer Manhole	⊕
Sanitary Sewer Cleanout	⊕
U/G Sanitary Sewer Line	----- SS
Above Ground Sanitary Sewer	----- A/G Sanitary Sewer
SS Forced Main Line LOS B (S.U.E.*)	----- FSS
SS Forced Main Line LOS C (S.U.E.*)	----- FSS
SS Forced Main Line LOS D (S.U.E.*)	----- FSS

MISCELLANEOUS:

Utility Pole	●
Utility Pole with Base	□
Utility Located Object	○
Utility Traffic Signal Box	⊠
Utility Unknown U/G Line LOS B (S.U.E.*)	----- ?UTL
U/G Tank; Water, Gas, Oil	□
Underground Storage Tank, Approx. Loc.	⊕
A/G Tank; Water, Gas, Oil	□
Geoenvironmental Boring	⊕
U/G Test Hole LOS A (S.U.E.*)	⊕
Abandoned According to Utility Records	AATUR
End of Information	E.O.I.

PAVEMENT SCHEDULE	
C1	PROP. APPROX. 3" ASPHALT CONCRETE SURFACE COURSE, TYPE S9.5B, AT AN AVERAGE RATE OF 165 LBS. PER SQ. YD. IN EACH OF TWO LAYERS.
C2	PROP. VAR. DEPTH ASPHALT CONCRETE SURFACE COURSE, TYPE S9.5B, AT AN AVERAGE RATE OF 110 LBS. PER SQ. YD. PER 1" DEPTH. TO BE PLACED IN LAYERS NOT TO EXCEED 2" IN DEPTH.
D1	PROP. APPROX. 4" ASPHALT CONCRETE INTERMEDIATE COURSE, TYPE I19.0C, AT AN AVERAGE RATE OF 456 LBS. PER SQ. YD.
D2	PROP. VAR. DEPTH ASPHALT CONCRETE INTERMEDIATE COURSE, TYPE I19.0C, AT AN AVERAGE RATE OF 114 LBS. PER SQ. YD. PER 1" DEPTH, TO BE PLACED IN LAYERS NOT LESS THAN 2 1/2" IN DEPTH OR GREATER THAN 4" IN DEPTH.
E1	PROP. APPROX. 4" ASPHALT CONCRETE BASE COURSE, TYPE B25.0C, AT AN AVERAGE RATE OF 456 LBS. PER SQ. YD.
E2	PROP. VAR. DEPTH ASPHALT CONCRETE BASE COURSE, TYPE B25.0C, AT AN AVERAGE RATE OF 114 LBS. PER SQ. YD. PER 1" DEPTH. TO BE PLACED IN LAYERS NOT LESS THAN 3" IN DEPTH OR GREATER THAN 5 1/2" IN DEPTH.
J1	7" INCIDENTAL STONE.
R1	2'-6" CONCRETE CURB AND GUTTER.
R2	9" X 12" CONCRETE CURB.
T1	EARTH MATERIAL.
U	EXISTING PAVEMENT.
W	WEDGING. SEE DETAIL.

NOTE: PAVEMENT EDGE SLOPES ARE 1:1 UNLESS SHOWN OTHERWISE.

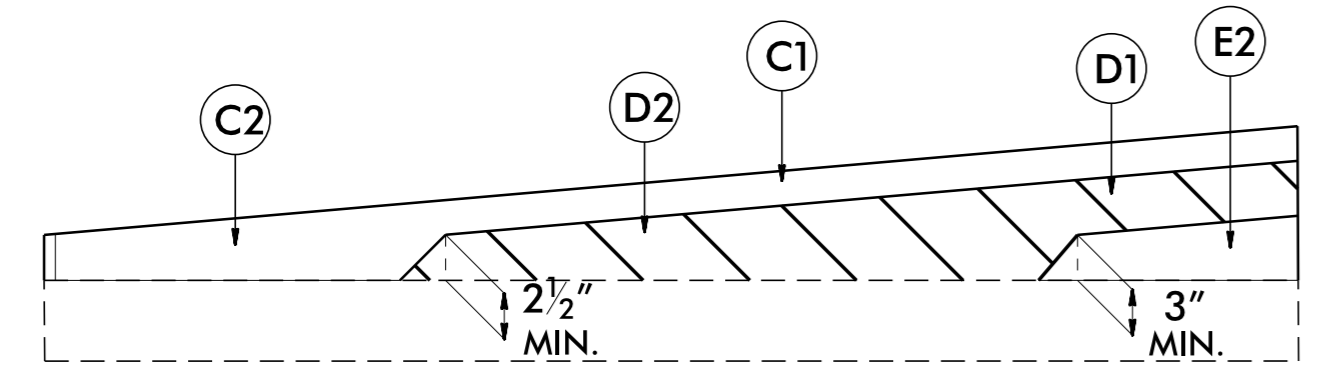
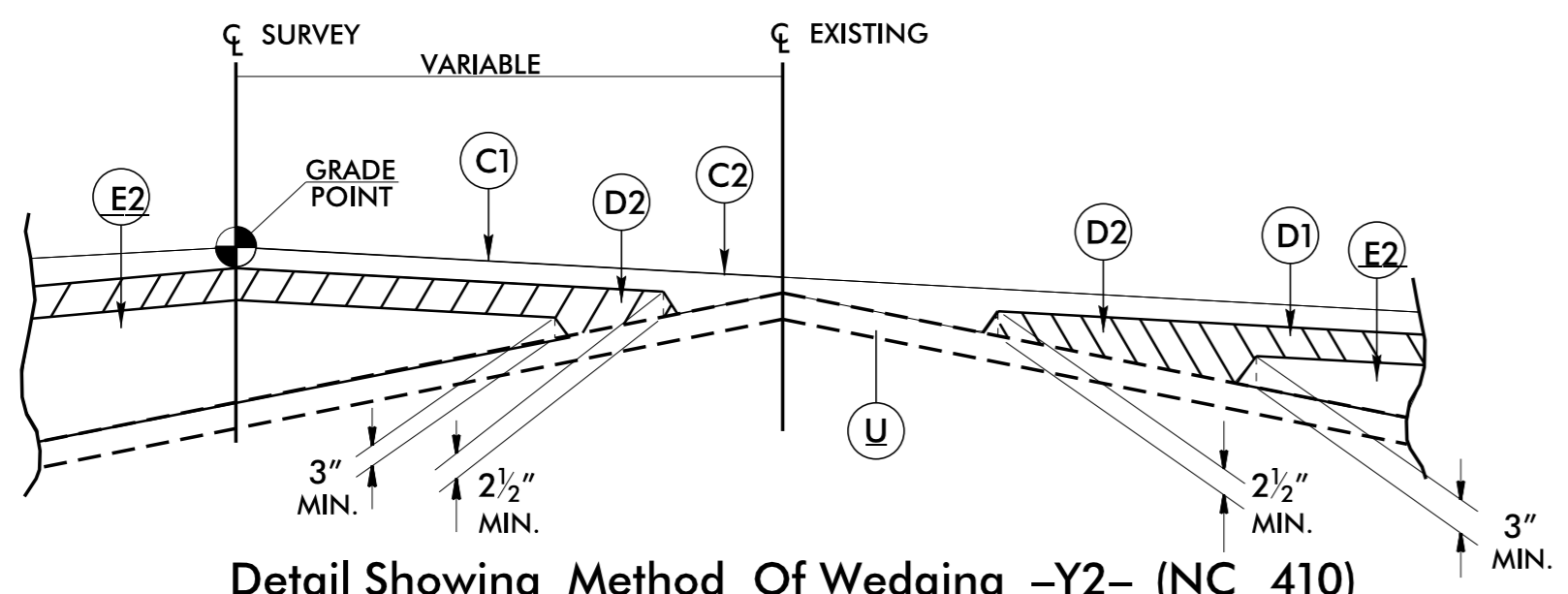

CONTRACTOR SHALL COORDINATE WITH LOCAL TRAFFIC SERVICES UNIT FOR PROPOSED SIGNS AND PLACEMENT OF ALL PAVEMENT MARKINGS.

FOR SIGNS AND PAVEMENT MARKINGS, CONTACT TRAFFIC SERVICES 910-364-0606, 14 DAYS PRIOR TO FINAL PLACEMENT.

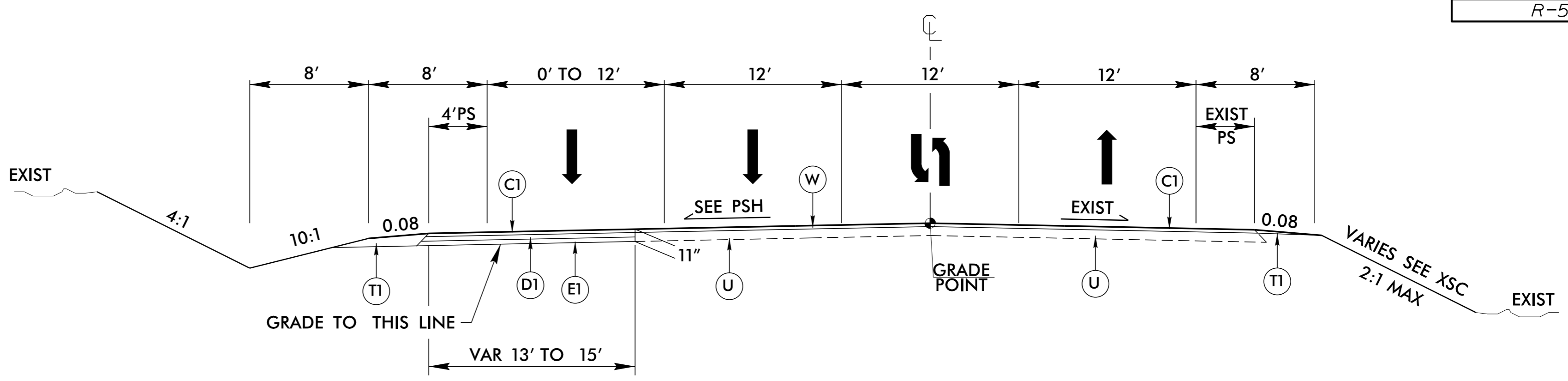

TYPICAL SECTION NO. 1
-L- (US 701) STA. 12+00.00 TO 28+30.00

TRANSITION FROM TYPICAL SECTION NO. 1 TO EXISTING
-L- (US 701) STA. 28+30 TO 32+40.00

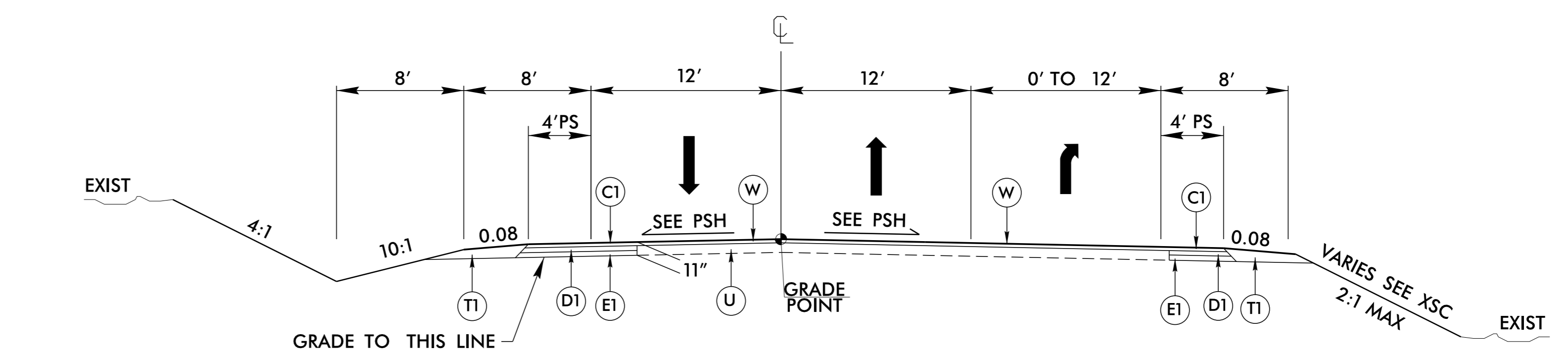

TYPICAL SECTION NO. 2
-Y2- (NC 410) STA. 11+25.00 TO 14+50.00

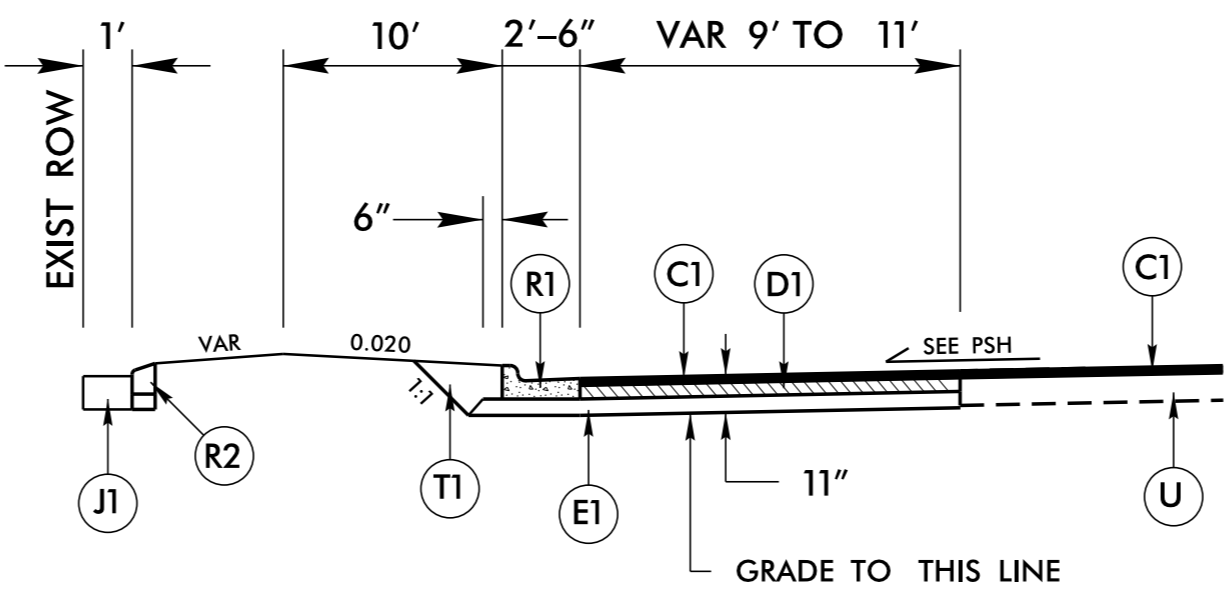

USE WITH TYPICAL SECTION NO.1 & 2 AT THE FOLLOWING LOCATIONS:

- L- STA 23+28.00 LT TO STA 27+75.00 LT
- Y2- STA 13+32.67 RT TO STA 14+50.00 RT

PROJECT NOTES

- The Contractor shall not work on both sides of the road simultaneously within the same area.
- Ingress and egress shall be maintained to all businesses and dwellings on the project.
- At the end of each workday, the Contractor shall be required to backfill any area adjacent to existing travelway that has been graded leaving no more than a 1" drop-off.
- A minimum of two-way, two-lane traffic (plus all existing left and right turn lanes) shall be maintained during periods of construction inactivity.
- The Contractor shall not be allowed to stop traffic for more than 5 minutes at a time in any one direction.
- During periods of construction inactivity, the difference in elevation between lanes shall not exceed 1-1/2 inch.
- Access to police and fire stations, fire hydrants, and hospitals shall be maintained at all times.
- During periods of construction inactivity, place cones/drums 3' from existing edge of pavement (travelway) as directed by the Engineer.
- Channelizing devices in work areas shall be spaced not greater than 50' on center in tangent areas, 45' on center in tapers, and 10' on center in radii, and shall be set 3' off the edge of travelway, unless otherwise indicated on plans.
- Contractor to install Erosion Control devices as directed by the Engineer.
- The contractor shall be responsible for the permanent staking of all Proposed Right of Way, Control of Access and Drainage Easements Per NCDOT Division 6 Special Provision in the contract.
- Contractor shall provide driveway turnouts at all soil or gravel drives as directed by the Engineer.

MILLING AT PAVEMENT TIE-INS

NOTES TO CONTRACTOR

For surface mixes over 1" in thickness, mill the existing pavement in accordance with the following sketch or as directed by the Engineer.

Locations shall include ties into existing concrete pavement, at bridge approaches where the bridge will not be resurfaced, and at the beginning and ending point of each resurfacing map.

Perform the work in accordance with Section 607 of the January 2018 North Carolina Department of Transportation Standard Specifications for Roads and Structures. Resurfacing will be accomplished at the same time as the milling operation.

6/2/09 29 MAY 2019 09:33 R-5013 US 701 at NC 410 Roadway Proj R-5013.Rdy.-tup.dgn

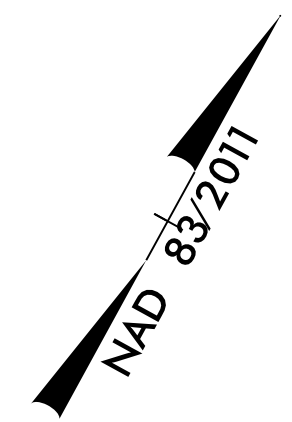

8/17/99

REVISIONS

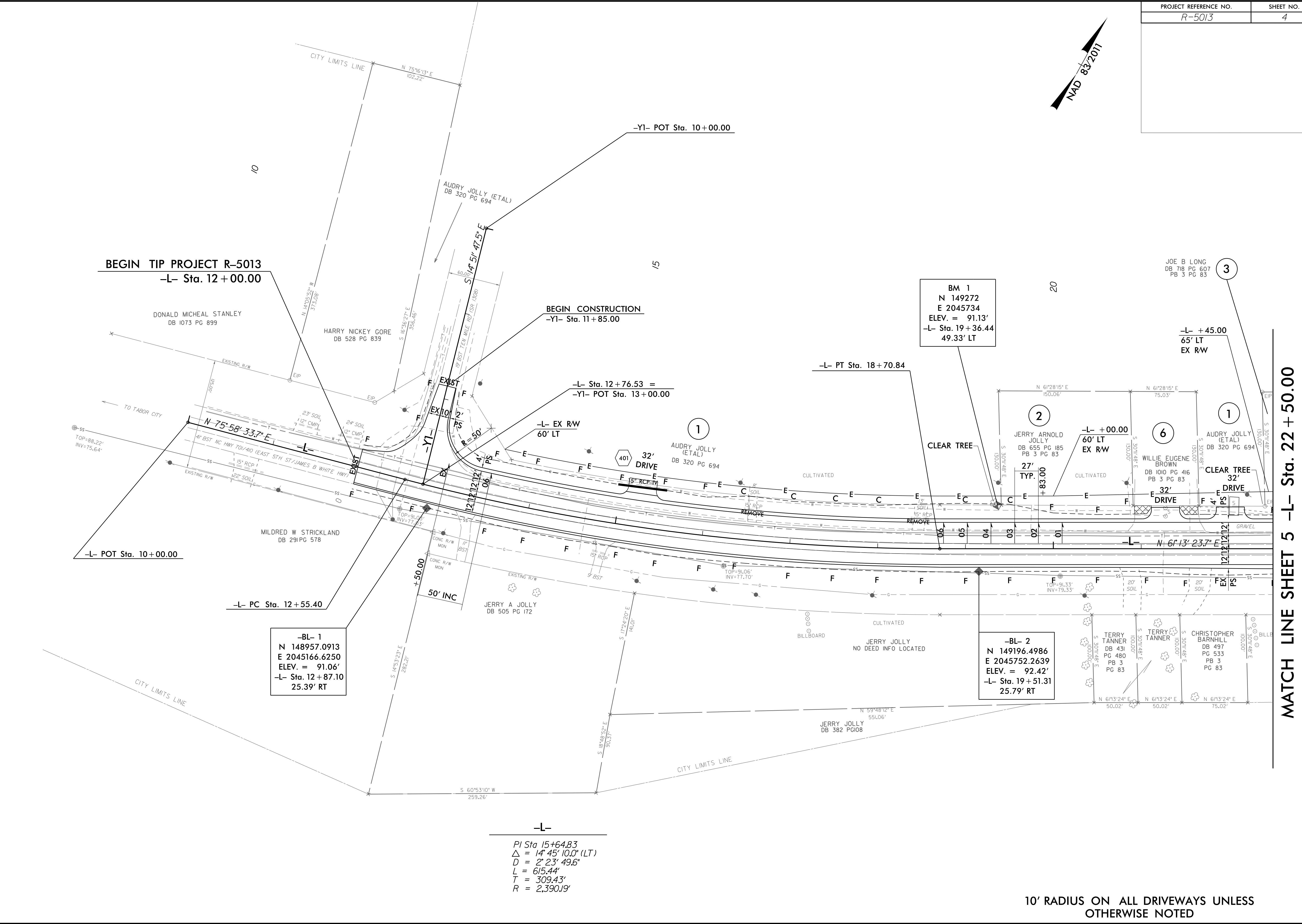

BEGIN TIP PROJECT R-5013
-L- Sta. 12+00.00

BEGIN CONSTRUCTION
-Y1- Sta. 11+85.00

BM 1
N 149272
E 2045734
ELEV. = 91.13'
-L- Sta. 19+36.44
49.33' LT

-BL- 1
N 148957.0913
E 2045166.6250
ELEV. = 91.06'
-L- Sta. 12+87.10
25.39' RT

-BL- 2
N 149196.4986
E 2045752.2639
ELEV. = 92.42'
-L- Sta. 19+51.31
25.79' RT

-L-
PI Sta 15+64.83
Δ = 14° 45' 10.0" (LT)
D = 2' 23' 49.6"
L = 615.44'
T = 309.43'
R = 2,390.19'

MATCH LINE SHEET 5 -L- Sta. 22 + 50.00

23-MAY-2019 09:33 AM 410\Roadway\Projects\R-5013_Prdy_psh-4.dgn 701 at NC 410\Roadway\Projects\R-5013_Prdy_psh-4.dgn

10' RADIUS ON ALL DRIVEWAYS UNLESS OTHERWISE NOTED

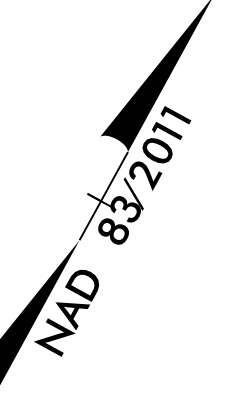

MATCH LINE SHEET 4 -L- Sta. 22 + 50.00

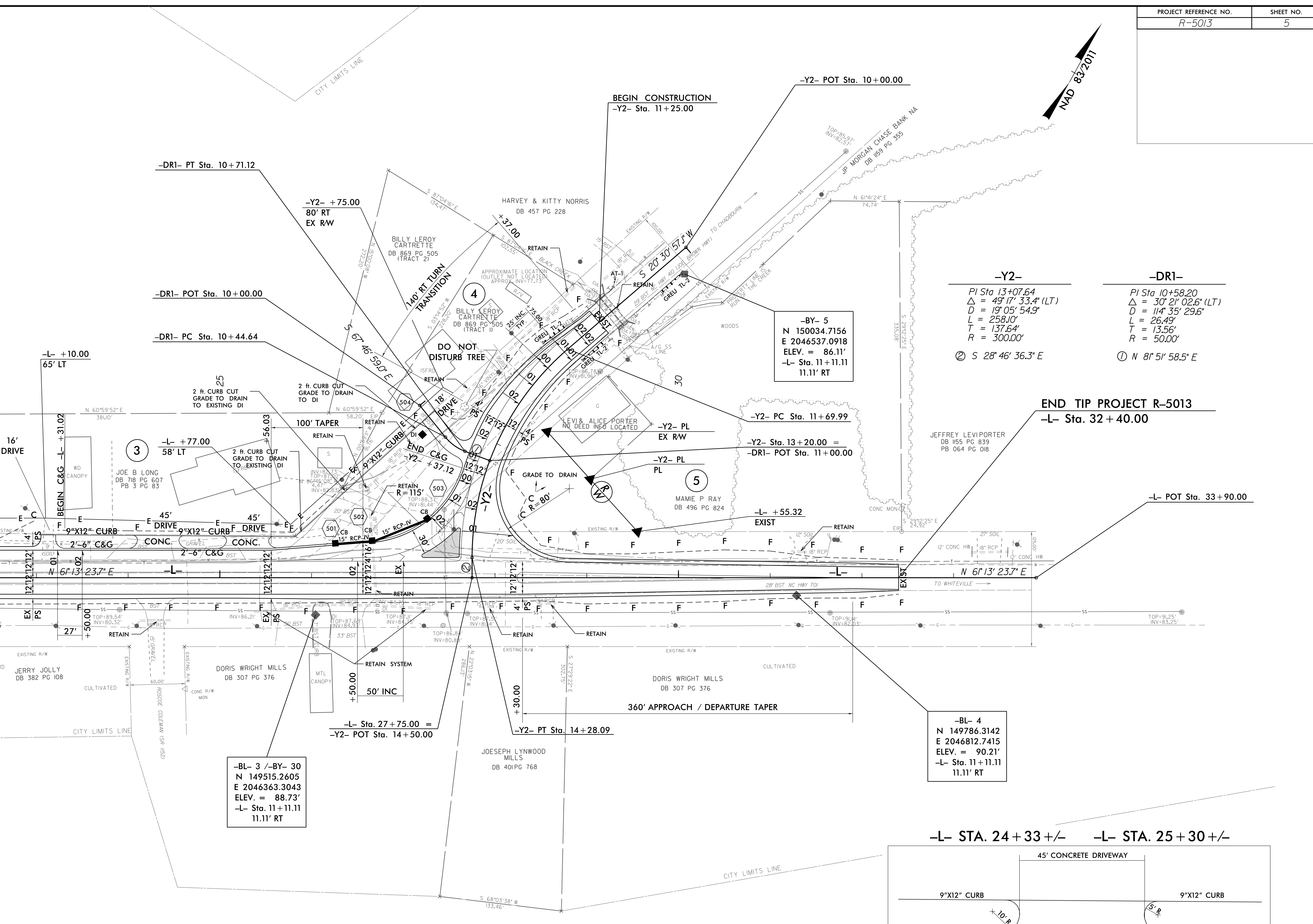

-Y2-	-DRI-
PI Sta 13+07.64	PI Sta 10+58.20
$\Delta = 49^{\circ}17'33.4''$ (LT)	$\Delta = 30^{\circ}21'02.6''$ (LT)
$D = 19^{\circ}05'54.9''$	$D = 114^{\circ}35'29.6''$
$L = 258.10'$	$L = 26.49'$
$T = 137.64'$	$T = 13.56'$
$R = 300.00'$	$R = 50.00'$
⊙ S 28°46'36.3° E	⊙ N 81°51'58.5° E

-BY- 5
N 150034.7156
E 2046537.0918
ELEV. = 86.11'
-L- Sta. 11+11.11
11.11' RT

-BL- 4
N 149786.3142
E 2046812.7415
ELEV. = 90.21'
-L- Sta. 11+11.11
11.11' RT

-BL- 3 /-BY- 30
N 149515.2605
E 2046363.3043
ELEV. = 88.73'
-L- Sta. 11+11.11
11.11' RT

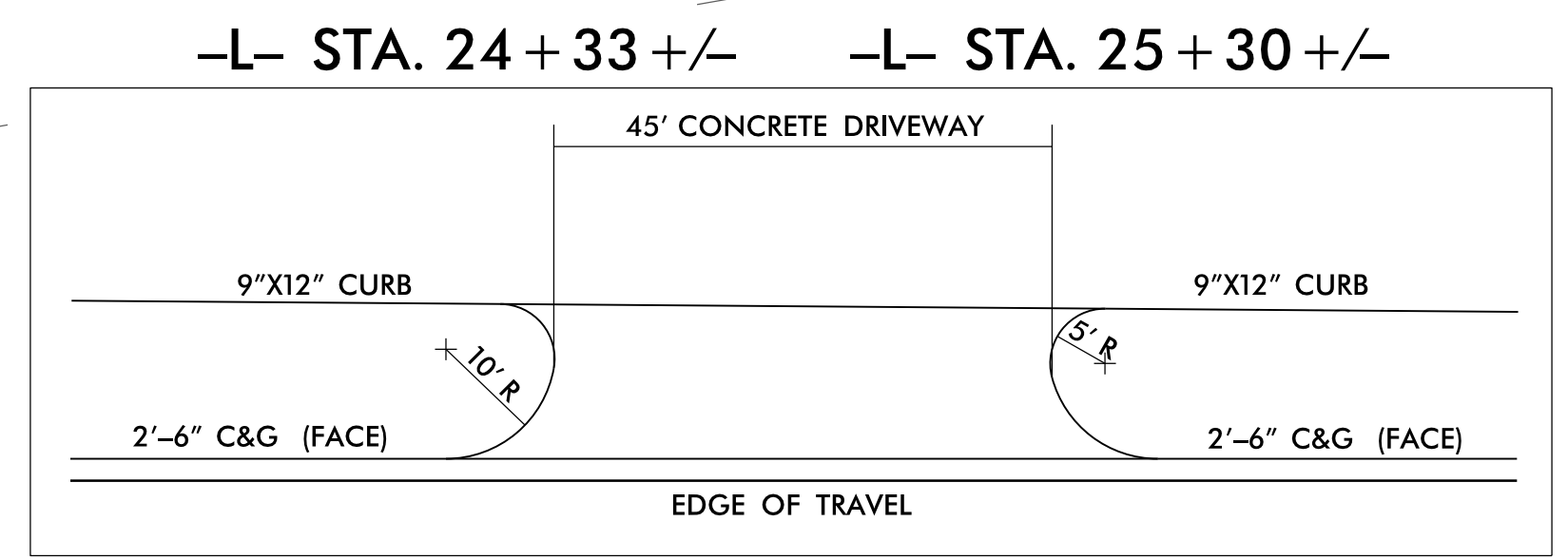

10' RADIUS ON ALL DRIVEWAYS UNLESS OTHERWISE NOTED

REVISIONS

8/17/99

23-MAY-2019 09:37 R-5013 US 701 at NC 410\Roadway\Proj\R-5013_Rdy_psh_5.dgn

5/14/99

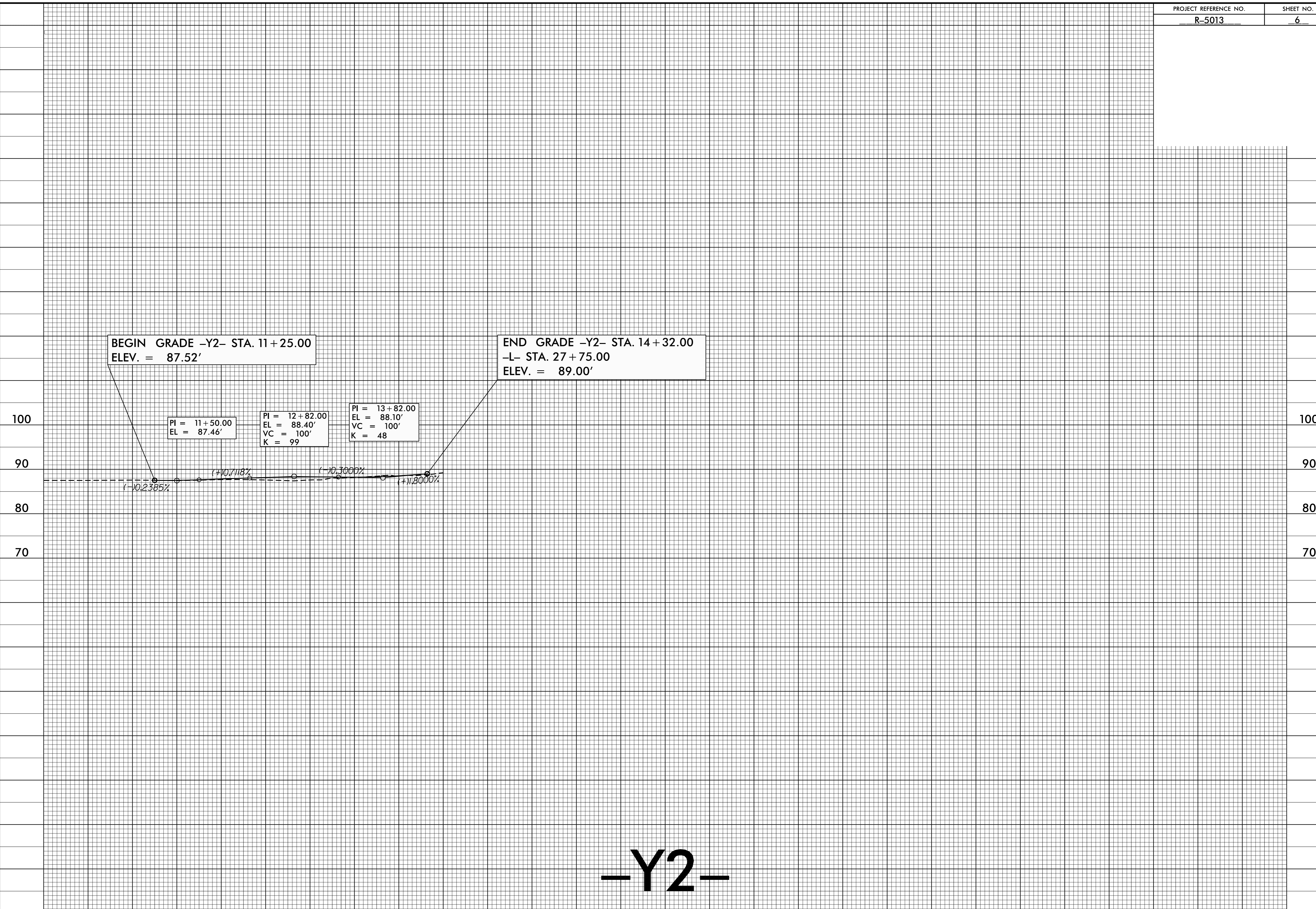

BEGIN GRADE -Y2- STA. 11+25.00
ELEV. = 87.52'

END GRADE -Y2- STA. 14+32.00
-L- STA. 27+75.00
ELEV. = 89.00'

PI = 11+50.00
EL = 87.46'

PI = 12+82.00
EL = 88.40'
VC = 100'
K = 99

PI = 13+82.00
EL = 88.10'
VC = 100'
K = 48

(-)0.2385%

(+)0.7118%

(-)0.3000%

(+)1.8000%

-Y2-

29-MAY-2019 09:33
 44441\STRM\5013 US 701 at NC 410\Roadway\Proj\R-5013.Rdy.plt.6-Y2.dgn

10+00 11+00 12+00 13+00 14+00

100
90
80
70

100
90
80
70

STATE OF NORTH CAROLINA
DEPARTMENT OF TRANSPORTATION

PAVEMENT MARKING PLAN
COLUMBUS COUNTY

LOCATION: US 70/NC 410 (JAMES B WHITE HIGHWAY/EAST
FIFTH STREET) AT NC 410 (JOE BROWN HIGHWAY)

TIP NO. R-5013	SHEET NO. PMP - 1
APPROVED: <i>[Signature]</i>	
DATE: 5/8/2019	
SEAL	



T.I.P.: R-5013

CONTRACT:

INDEX

SHEET NO.	DESCRIPTION
PMP-1	PAVEMENT MARKING PLAN TITLE AND SCHEDULE SHEET
PMP-1A	PAVEMENT MARKING DETAILS
PMP-2-3	PAVEMENT MARKING DETAIL

R-5013 PAVEMENT MARKING SCHEDULE

SYMBOL	DESCRIPTION	FINAL PAVEMENT MARKINGS
TA	WHITE EDGELINE	THERMOPLASTIC (4", 90 MILS)
TD	3 FT. - 9 FT./SP WHITE MINISKIP	THERMOPLASTIC (4", 90 MILS)
TE	WHITE SOLID LANE LINE	
TF	10 FT. YELLOW SKIP	
TH	YELLOW SINGLE CENTER	
TI	YELLOW DOUBLE CENTER	
TC	WHITE SKIP LINE	
TN	WHITE GORELINE	THERMOPLASTIC (8", 90 MILS)
TO	WHITE DIAGONAL	
TP	YELLOW DIAGONAL	
UA	LEFT TURN ARROW	THERMOPLASTIC PAVEMENT MARKING SYMBOLS (90 MILS)
UB	RIGHT ARROW	
UI	ALPHANUMERIC CHAR.	THERMOPLASTIC PAVEMENT MARKING SYMBOLS (90 MILS)
MA	PERMANENT RAISED PAVEMENT MARKERS	
MB	YELLOW & YELLOW CRYSTAL & RED	

ROADWAY STANDARD DRAWING

THE FOLLOWING ROADWAY STANDARDS AS APPEAR IN "ROADWAY STANDARD DRAWINGS" - PROJECT SERVICES UNIT - N.C. DEPARTMENT OF TRANSPORTATION - RALEIGH, N.C., DATED JANUARY 2018 ARE APPLICABLE TO THIS PROJECT AND BY REFERENCE HEREBY ARE CONSIDERED A PART OF THESE PLANS:

STD. NO.	TITLE
1205.01	PAVEMENT MARKINGS - LINE TYPES AND OFFSETS
1205.02	PAVEMENT MARKINGS - TWO-LANE AND MULTILANE ROADWAYS
1205.04	PAVEMENT MARKINGS - INTERSECTIONS
1205.05	PAVEMENT MARKINGS - TURN LANES
1205.06	PAVEMENT MARKINGS - LANE DROPS
1205.08	PAVEMENT MARKINGS - SYMBOLS AND WORD MESSAGES
1250.01	RAISED PAVEMENT MARKERS - INSTALLATION SPACING
1251.01	RAISED PAVEMENT MARKERS - PERMANENT AND TEMPORARY
1261.01	GUARDRAIL AND BARRIER DELINEATORS - INSTALLATION SPACING
1261.02	GUARDRAIL AND BARRIER DELINEATORS - TYPES AND MOUNTING
1262.01	GUARDRAIL END DELINEATION

GENERAL NOTES

THE FOLLOWING GENERAL NOTES APPLY AT ALL TIMES FOR THE DURATION OF THE CONSTRUCTION PROJECT, EXCEPT WHEN OTHERWISE NOTED IN THE PLAN, OR DIRECTED BY THE ENGINEER.

- A) INSTALL PAVEMENT MARKINGS AND PAVEMENT MARKERS ON THE FINAL SURFACE AS FOLLOWS:

ROAD NAME	MARKING	MARKER
NC HWY 701/410	THERMOPLASTIC	RAISED
TEN MILE ROAD	THERMOPLASTIC	RAISED
NC HWY 410	THERMOPLASTIC	RAISED

- B) TIE PROPOSED PAVEMENT MARKING LINES TO EXISTING PAVEMENT MARKING LINES.
 C) REMOVE/REPLACE ANY CONFLICTING/DAMAGED PAVEMENT MARKINGS AND MARKERS.
 D) PASSING ZONES WILL BE DETERMINED IN THE FIELD AND MUST BE APPROVED BY THE ENGINEER.
 E) UNLESS OTHERWISE SPECIFIED, HEATED-IN-PLACE THERMOPLASTIC MAY BE USED IN LIEU OF EXTRUDED THERMOPLASTIC FOR STOP BARS, SYMBOLS, CHARACTERS AND DIAGONALS. IF HEATED-IN-PLACE IS USED, IT SHALL BE PAID FOR USING THE EXTRUDED THERMOPLASTIC PAY ITEM.
 F) UNLESS OTHERWISE SPECIFIED, HEATED-IN-PLACE THERMOPLASTIC MAY BE USED IN LIEU OF COLD APPLIED PLASTIC FOR STOP BARS, SYMBOLS, CHARACTERS AND DIAGONALS ON ASPHALT OR CONCRETE ROADWAYS. IF HEATED-IN-PLACE IS USED, IT SHALL BE PAID FOR USING THE COLD APPLIED PAY ITEM.

PLAN PREPARED BY: N.C.D.O.T. SIGNING AND DELINEATION UNIT

A. ALOUDWAH, PE SIGNING & DELINEATION REGIONAL ENGINEER
 M. TRACEY, PE SIGNING & DELINEATION PROJECT DESIGN ENGINEER

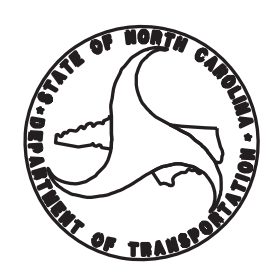

SYSTEMS
SERVICES
GROUP

TIP NO. P-5013	SHEET NO. PMP-1A
APPROVED: <i>[Signature]</i>	
DATE: 5/8/2019	
SEAL	

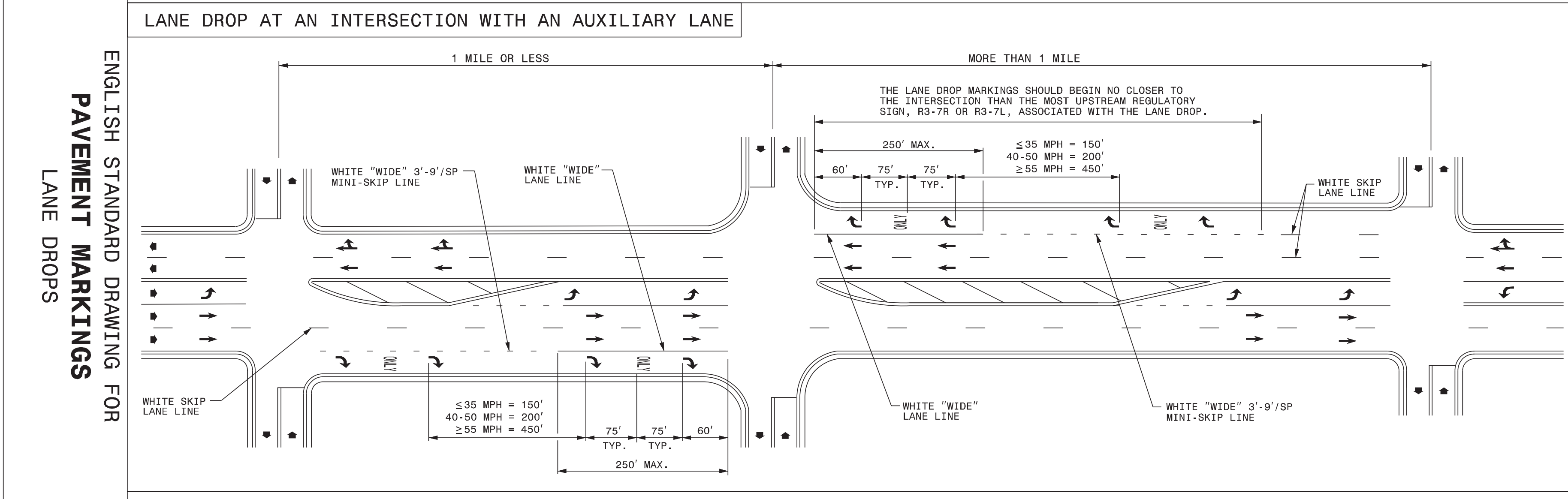
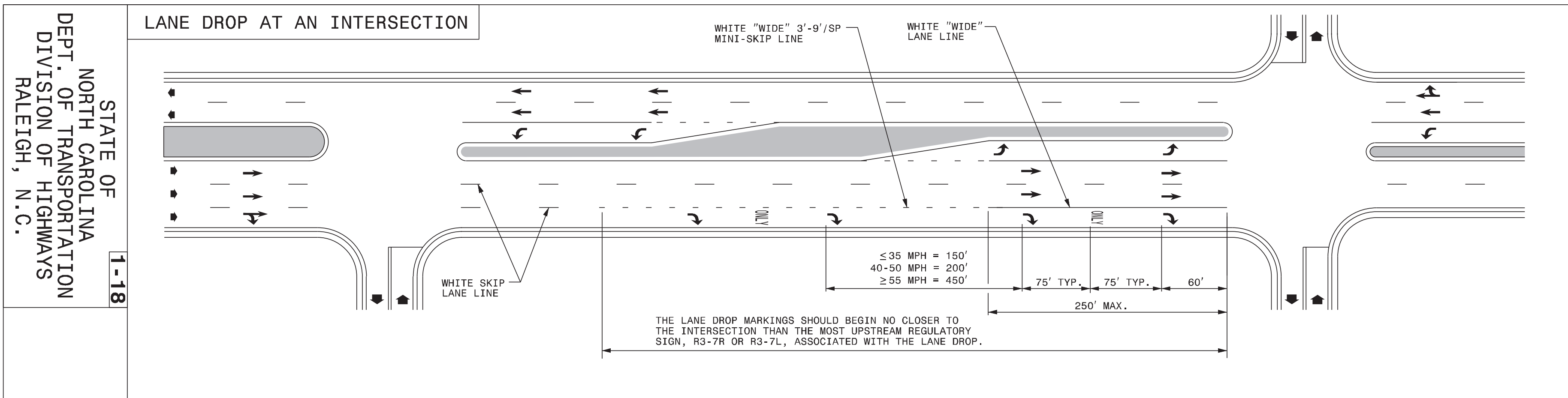

GENERAL NOTES:

- 1- USE THE GUIDANCE SHOWN ON THE ABOVE DETAILS IN CONJUNCTION WITH INTERSECTION GUIDANCE SHOWN ON ROADWAY STANDARD DRAWING 1205.04.
- 2- LANE LINES INDICATED AS "WIDE" SHALL BE AT LEAST TWICE THE WIDTH OF THE NORMAL LINE.

LEGEND	
W = WIDTH OF TRAVEL LANE	ONLY PAVEMENT MARKING SYMBOLS & CHARACTERS
■ DIRECTION OF TRAFFIC FLOW	

SHEET 1 OF 5
1205.06

SHEET 1 OF 5
1205.06

**REVISED PAVEMENT MARKING
ROADWAY STANDARD DRAWING**

STATE OF NORTH CAROLINA
DEPT. OF TRANSPORTATION
DIVISION OF HIGHWAYS
RALEIGH, N.C.

STATE OF NORTH CAROLINA
DEPT. OF TRANSPORTATION
DIVISION OF HIGHWAYS
RALEIGH, N.C.

ENGLISH STANDARD DRAWING FOR
PAVEMENT MARKINGS
LANE DROPS

ENGLISH STANDARD DRAWING FOR
PAVEMENT MARKINGS
LANE DROPS

C:\Users\mmtracey\Documents\Projects\1205.06\Traffic\1205.06_Pavement_Markings.dwg 07/19/17 User: mmtracey

TIP NO.	SHEET NO.
R-5013	PMP-2
APPROVED: <i>Logan Harrison</i>	
DATE: 5/8/2019	
SEAL	

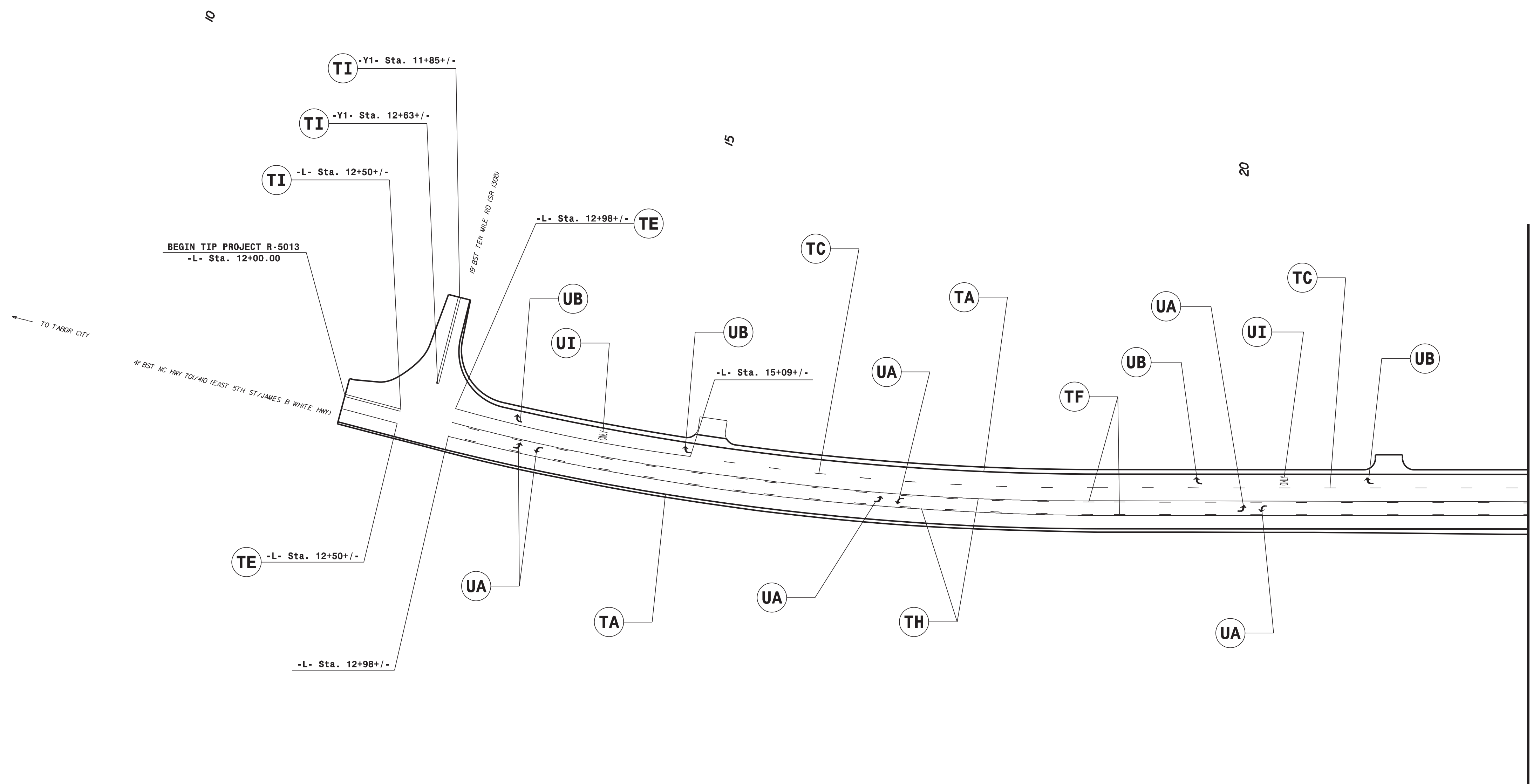
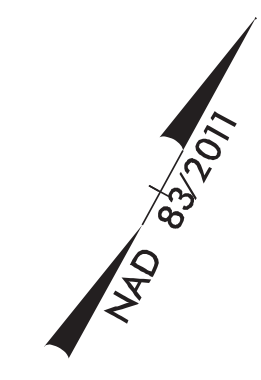
C:\Users\jgou\Documents\Projects\5013\Traffic\ Pavement Markings\ PMP-3.dgn
 User: jgou

PAVEMENT MARKING DETAIL

APPROVED: *William Harrison*
 DATE: 5/8/2019
 SEAL: 

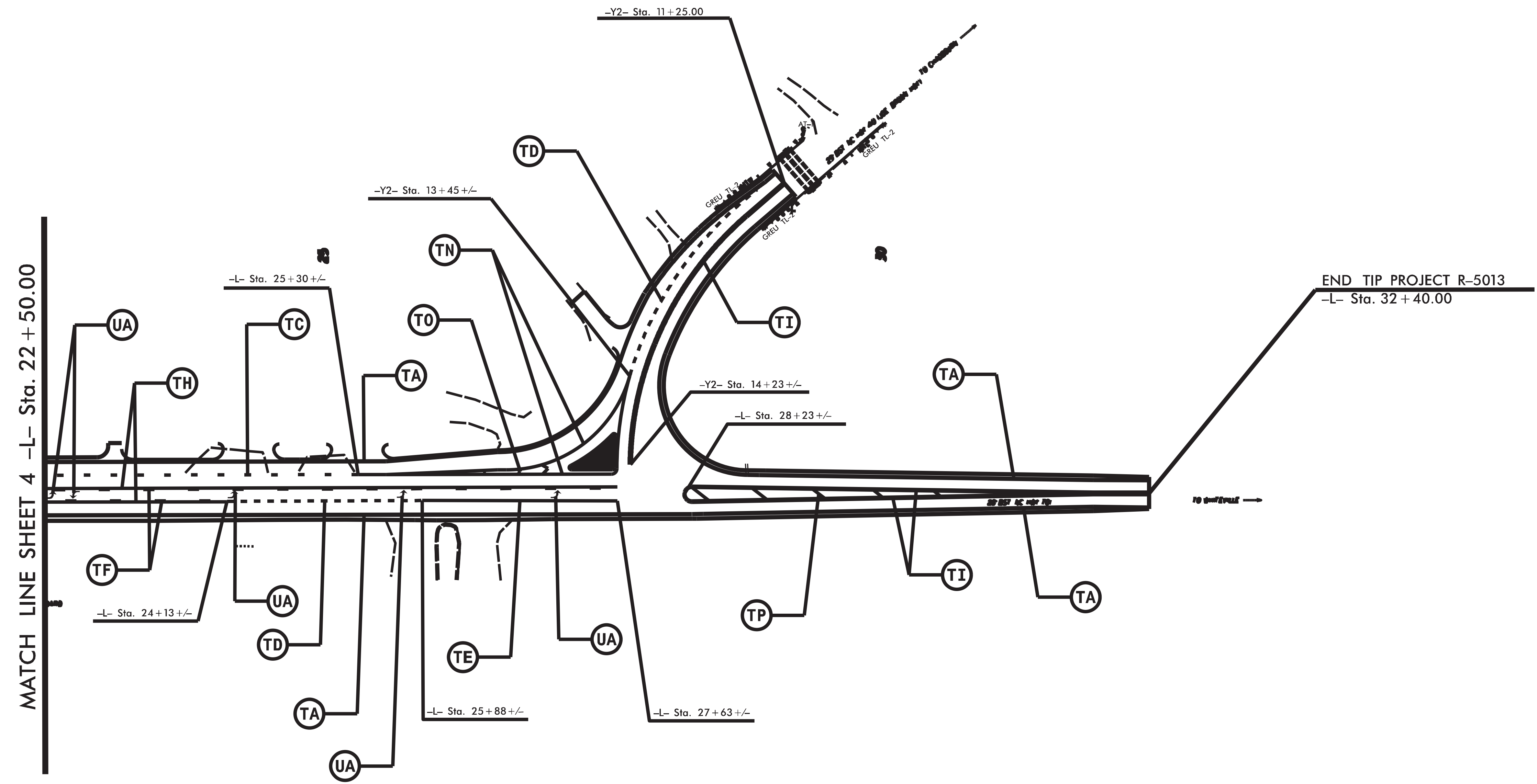
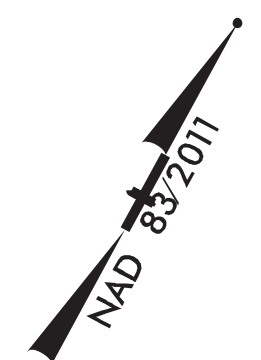

SYSTEMS
 CONSULTANTS
 ENGINEERS
 ARCHITECTS
 PLANNERS
 INCORPORATED
 10000
 WILSON
 ROAD
 SUITE 100
 RALEIGH, NC 27615
 TEL: 919.871.1000
 FAX: 919.871.1001
 WWW.SCEA-NC.COM

PAVEMENT MARKING DETAIL

TIP PROJECT: R-5013

STATE OF NORTH CAROLINA
 DIVISION OF HIGHWAYS
 PLAN FOR PROPOSED
 HIGHWAY EROSION CONTROL
COLUMBUS COUNTY

LOCATION: US 701/NC 410 (JAMES B WHITE HIGHWAY/EAST FIFTH STREET) AT NC 410 (JOE BROWN HIGHWAY)

TYPE OF WORK: GRADING, PAVING, DRAINAGE, SIGNING, AND PAVEMENT MARKING

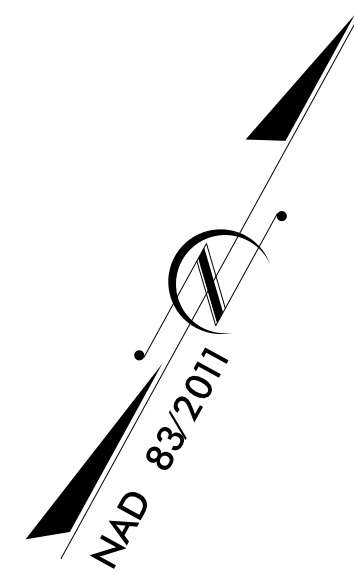

STATE	STATE PROJECT REFERENCE NO.	SHEET NO.	TOTAL SHEETS
N.C.	R-5013	EC-1	
STATE PROJ. NO.	F.A. PROJ. NO.	DESCRIPTION	

EROSION AND SEDIMENT CONTROL MEASURES

Std. #	Description	Symbol
1630.05	Temporary Silt Ditch	TD
1630.05	Temporary Diversion	TD
1605.01	Temporary Silt Fence	
1606.01	Special Sediment Control Fence	~ ~ ~
1622.01	Temporary Berms and Slope Drains	— T —
1630.02	Silt Basin Type B	▨
1633.01	Temporary Rock Silt Check Type-A	▩
	Temporary Rock Silt Check Type-A with Matting and Polyacrylamide (PAM)	▩
1633.02	Temporary Rock Silt Check Type-B	▩
	Wattle / Coir Fiber Wattle	— W —
	Wattle / Coir Fiber Wattle with Polyacrylamide (PAM)	— W —
1634.01	Temporary Rock Sediment Dam Type-A	▩
1634.02	Temporary Rock Sediment Dam Type-B	▩
1635.01	Rock Pipe Inlet Sediment Trap Type-A	⊓
1635.02	Rock Pipe Inlet Sediment Trap Type-B	⊓
1630.04	Stilling Basin	▭
1630.06	Special Stilling Basin	▭
	Rock Inlet Sediment Trap:	
1632.01	Type A	A
1632.02	Type B	B
1632.05	Type C	C
	Skimmer Basin	▭
	Tiered Skimmer Basin	▭
	Infiltration Basin	▭

THIS PROJECT CONTAINS EROSION CONTROL PLANS FOR CLEARING AND GRUBBING PHASE OF CONSTRUCTION.

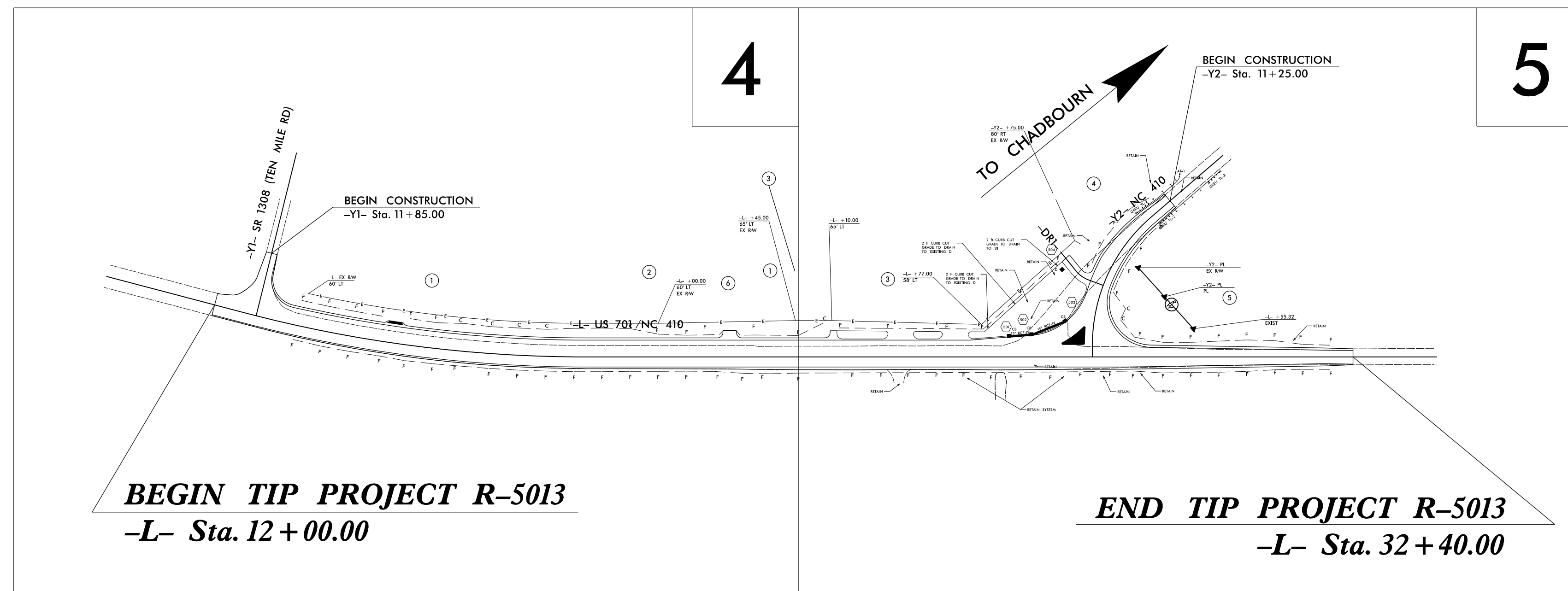

ROADSIDE ENVIRONMENTAL UNIT
 DIVISION OF HIGHWAYS
 STATE OF NORTH CAROLINA

THESE EROSION AND SEDIMENT CONTROL PLANS COMPLY WITH THE REGULATIONS SET FORTH BY THE NCG-010000 GENERAL CONSTRUCTION PERMIT EFFECTIVE AUGUST 3, 2011 ISSUED BY THE NORTH CAROLINA DEPARTMENT OF ENVIRONMENTAL QUALITY DIVISION OF WATER RESOURCES.

Prepared in the Office of:
ROADSIDE ENVIRONMENTAL UNIT
 1 South Wilmington St.
 Raleigh, NC 27611

2018 STANDARD SPECIFICATIONS

Designed by:
Noelle Ring 3456
 NAME LEVEL III CERTIFICATION NO.

Roadway Standard Drawings

The following roadway english standards as appear in "Roadway Standard Drawings"- Roadway Design Unit - N. C. Department of Transportation - Raleigh, N. C., dated January 2018 and the latest revision thereto are applicable to this project and by reference hereby are considered a part of these plans.

1604.01 Railroad Erosion Control Detail	1632.01 Rock Inlet Sediment Trap Type A
1605.01 Temporary Silt Fence	1632.02 Rock Inlet Sediment Trap Type J
1606.01 Special Sediment Control Fence	1632.03 Rock Inlet Sediment Trap Type C
1607.01 Gravel Construction Entrance	1633.01 Temporary Rock Silt Check Type A
1622.01 Temporary Berms and Slope Drains	1633.02 Temporary Rock Silt Check Type J
1630.01 Riser Basin	1634.01 Temporary Rock Sediment Dam Type A
1630.02 Silt Basin Type J	1634.02 Temporary Rock Sediment Dam Type J
1630.03 Temporary Silt Ditch	1635.01 Rock Pipe Inlet Sediment Trap Type A
1630.04 Stilling Basin	1635.02 Rock Pipe Inlet Sediment Trap Type J
1630.05 Temporary Diversion	1640.01 Coir Fiber Wattle
1630.06 Special Stilling Basin	1645.01 Temporary Stream Crossing
1631.01 Matting Installation	

PROJECT REFERENCE NO. <i>R-5013</i>	SHEET NO. <i>EC-2</i>
RW SHEET NO.	
ROADWAY DESIGN ENGINEER	HYDRAULICS ENGINEER

WATTLE WITH POLYACRYLAMIDE (PAM) DETAIL

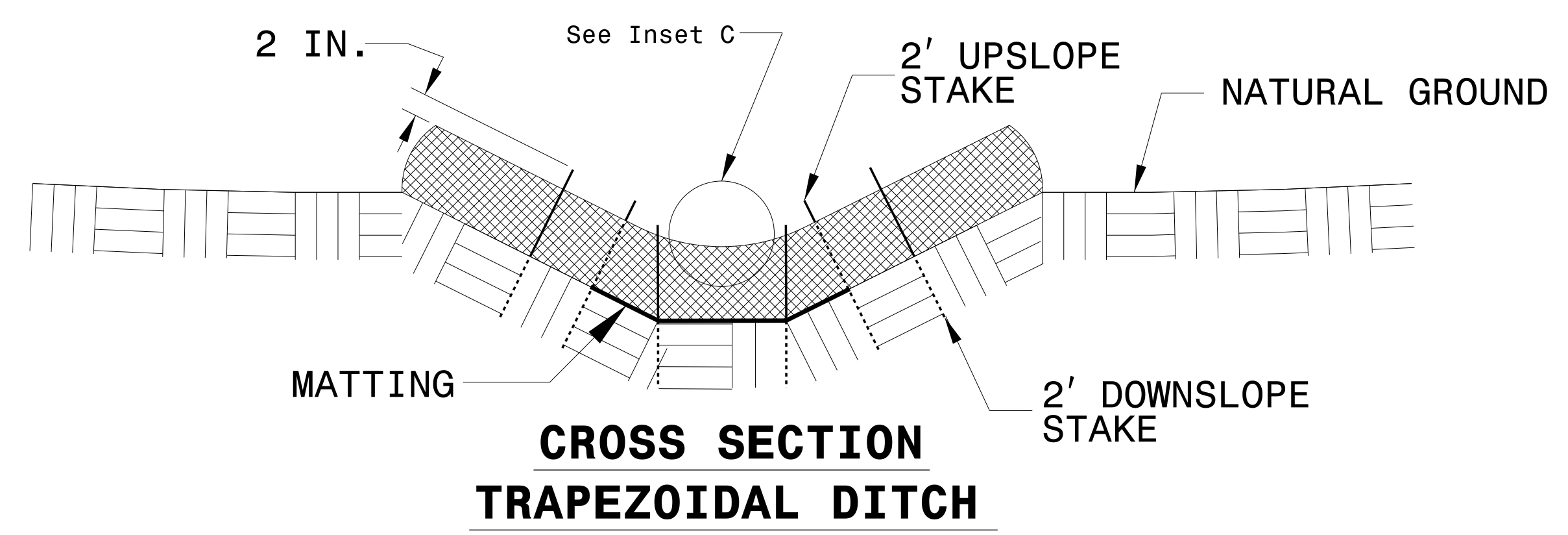
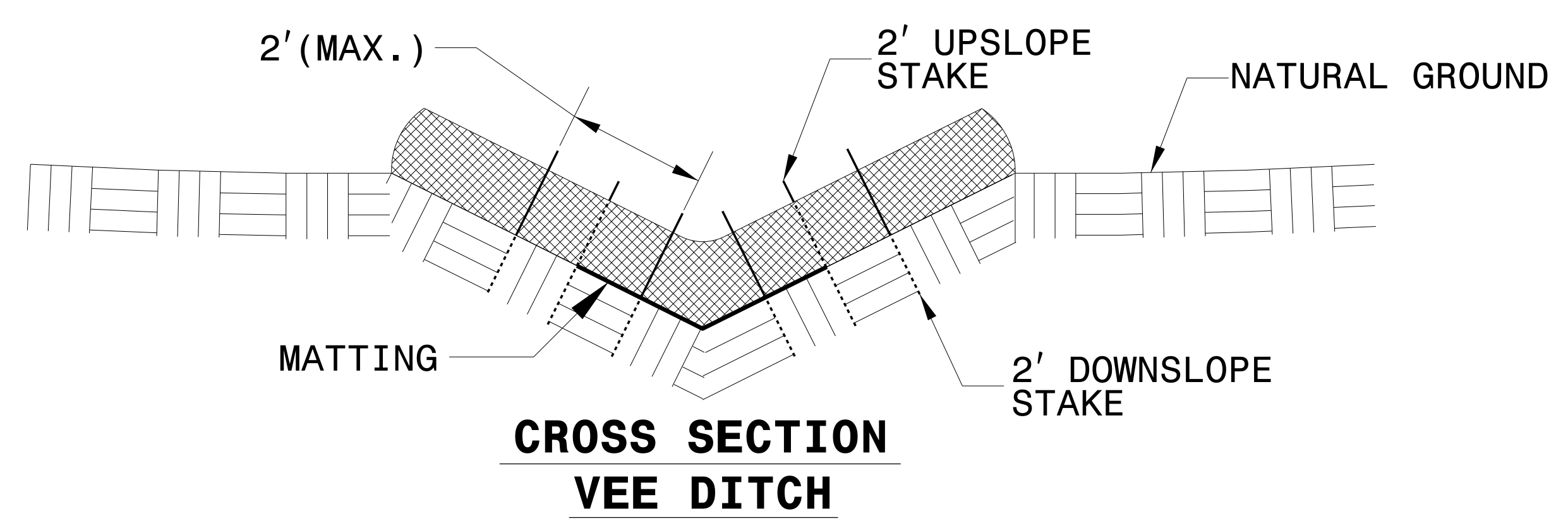
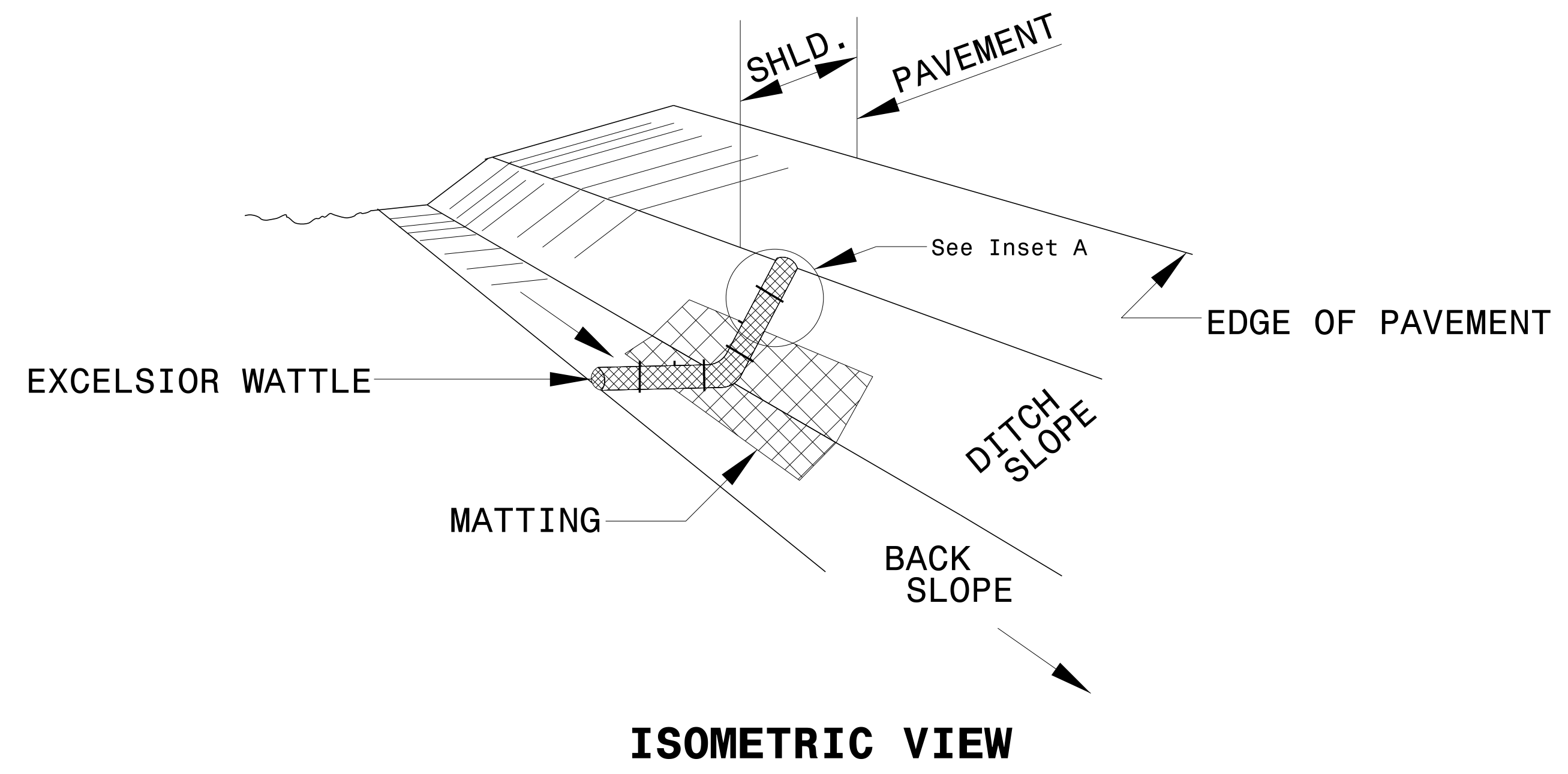

- NOTES:
- USE MINIMUM 12 IN. DIAMETER EXCELSIOR WATTLE.
 - USE 2 FT. WOODEN STAKES WITH A 2 IN. BY 2 IN. NOMINAL CROSS SECTION.
 - ONLY INSTALL WATTLE(S) TO A HEIGHT IN DITCH SO FLOW WILL NOT WASH AROUND WATTLE AND SCOUR DITCH SLOPES AND AS DIRECTED.
 - INSTALL A MINIMUM OF 2 UPSLOPE STAKES AND 4 DOWNSLOPE STAKES AT AN ANGLE TO WEDGE WATTLE TO BOTTOM OF DITCH.
 - PROVIDE STAPLES MADE OF 0.125 IN. DIAMETER STEEL WIRE FORMED INTO A U SHAPE NOT LESS THAN 12" IN LENGTH.
 - INSTALL STAPLES APPROXIMATELY EVERY 1 LINEAR FOOT ON BOTH SIDES OF WATTLE AND AT EACH END TO SECURE IT TO THE SOIL.
 - INSTALL MATTING IN ACCORDANCE WITH SECTION 1631 OF THE STANDARD SPECIFICATIONS.
 - PRIOR TO POLYACRYLAMIDE (PAM) APPLICATION, OBTAIN A SOIL SAMPLE FROM PROJECT LOCATION, AND FROM OFFSITE MATERIAL, AND ANALYZE FOR APPROPRIATE PAM FLOCCULANT TO BE APPLIED TO EACH WATTLE.
 - INITIALLY APPLY 2 OUNCES OF ANIONIC OR NEUTRALLY CHARGED PAM OVER WATTLE WHERE WATER WILL FLOW AND 1 OUNCE OF PAM ON MATTING ON EACH SIDE OF WATTLE. REAPPLY PAM AFTER EVERY RAINFALL EVENT THAT IS EQUAL TO OR EXCEEDS 0.50 IN.

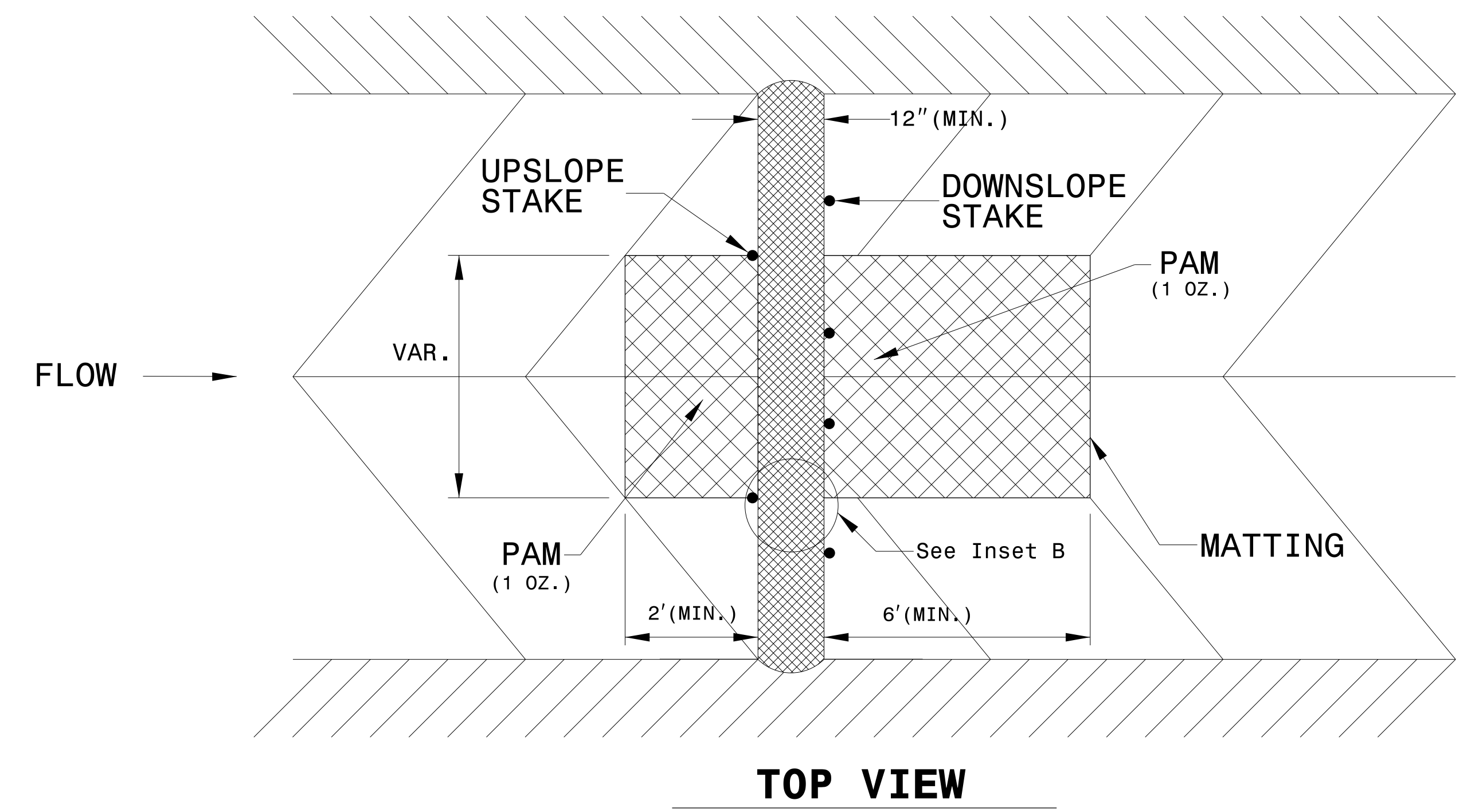
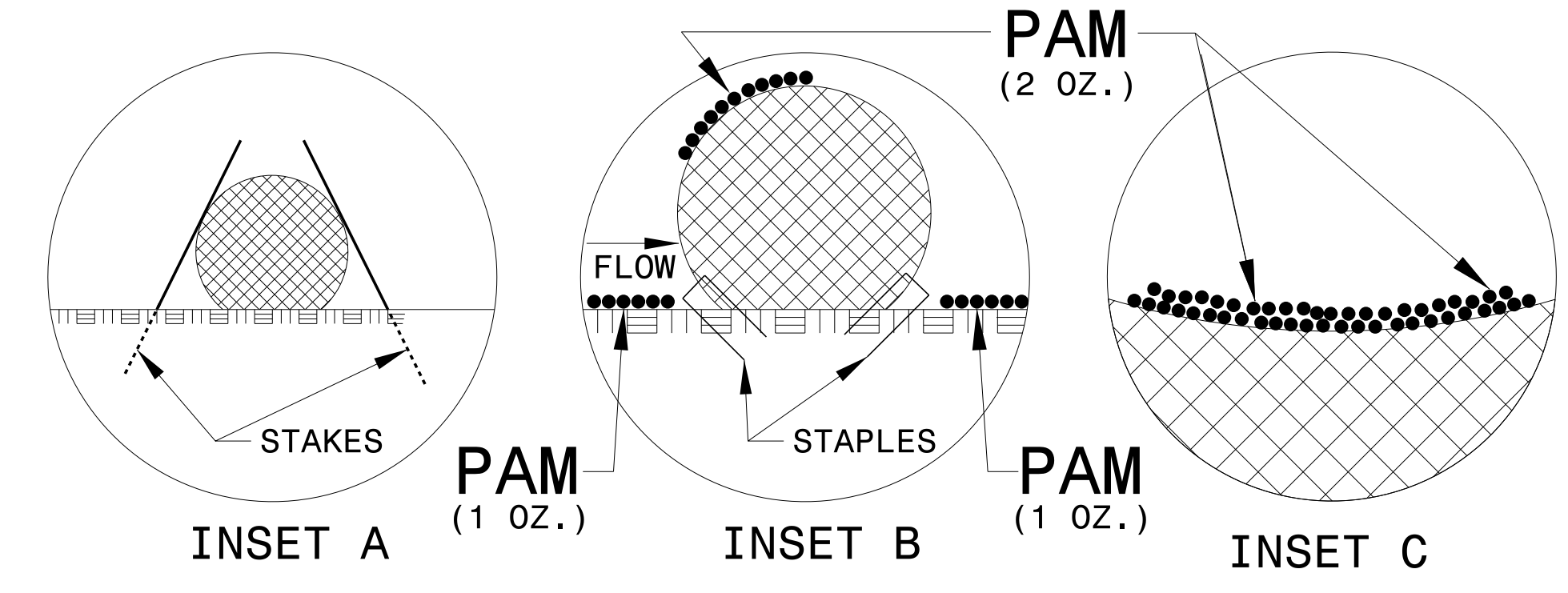

PROJECT REFERENCE NO. R-5013	SHEET NO. EC-2A
RW SHEET NO.	
ROADWAY DESIGN ENGINEER	HYDRAULICS ENGINEER

SILT FENCE WATTLE BREAK DETAIL

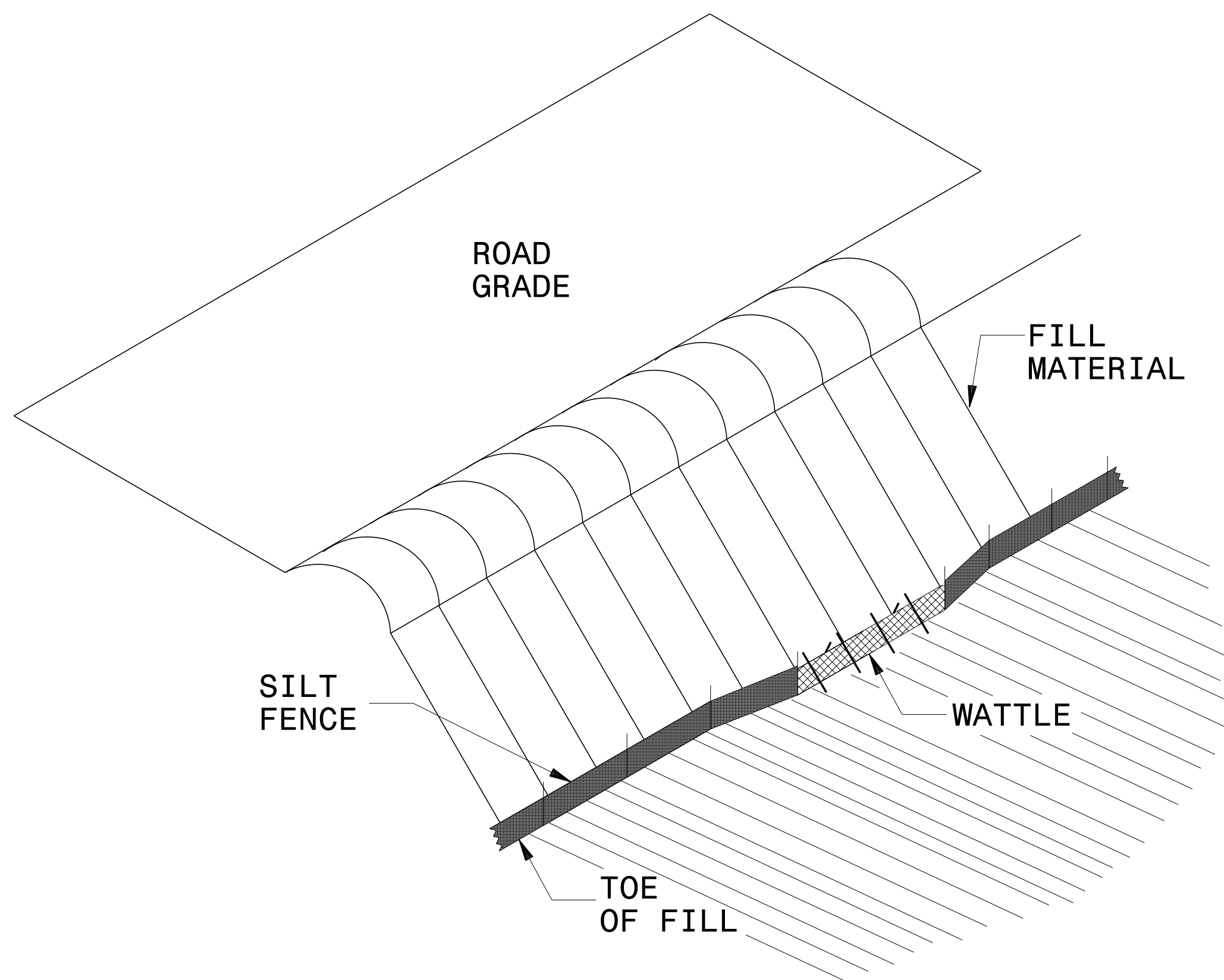

ISOMETRIC VIEW

NOTES:

- USE MINIMUM 12 IN. DIAMETER EXCELSIOR WATTLE AND LENGTH OF 10 FT.
- EXCAVATE A 1 TO 2 INCH TRENCH FOR WATTLE TO BE PLACED.
- DO NOT PLACE WATTLE ON TOE OF SLOPE.
- USE 2 FT. WOODEN STAKES WITH A 2 IN. BY 2 IN. NOMINAL CROSS SECTION.
- INSTALL A MINIMUM OF 2 UPSLOPE STAKES AND 4 DOWNSLOPE STAKES AT AN ANGLE TO WEDGE WATTLE TO GROUND.
- PROVIDE STAPLES MADE OF 0.125 IN. DIAMETER STEEL WIRE FORMED INTO A U SHAPE NOT LESS THAN 12" IN LENGTH.
- INSTALL STAPLES APPROXIMATELY EVERY 1 LINEAR FOOT ON BOTH SIDES OF WATTLE AND AT EACH END TO SECURE IT TO THE SOIL.
- WATTLE INSTALLATION CAN BE ON OUTSIDE OF THE SILT FENCE AS DIRECTED.
- INSTALL TEMPORARY SILT FENCE IN ACCORDANCE WITH SECTION 1605 OF THE STANDARD SPECIFICATIONS.

INSET A

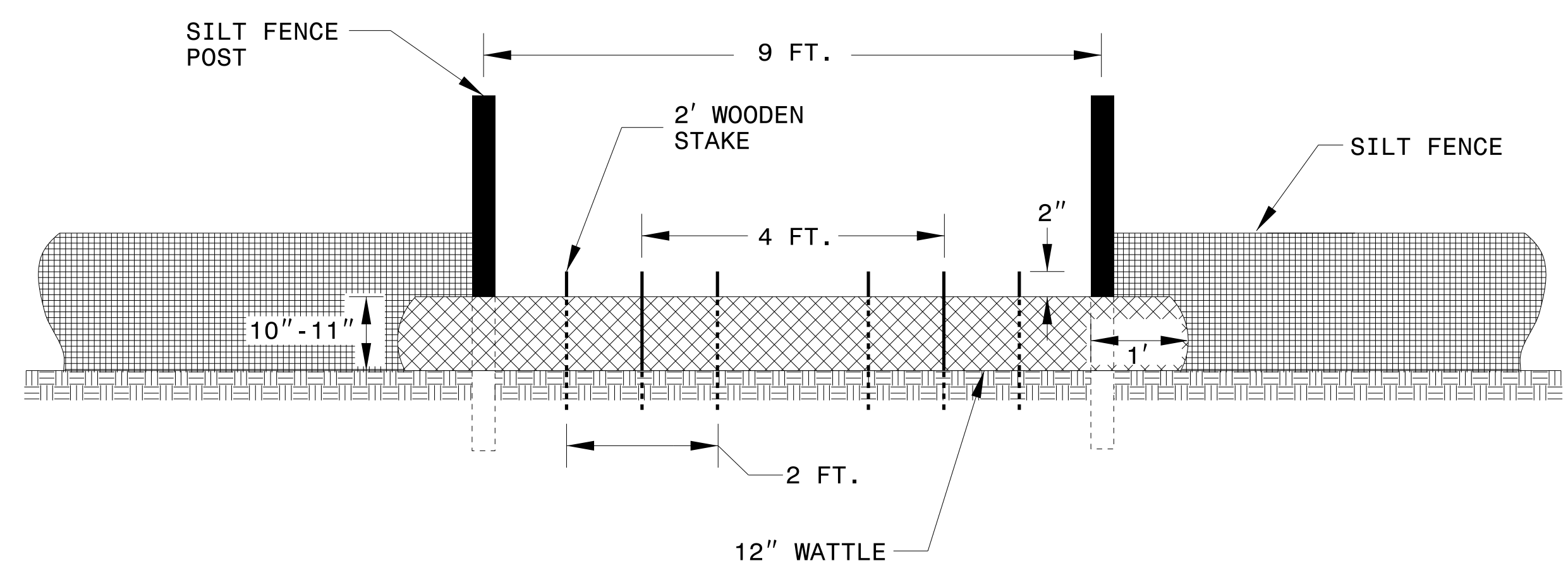
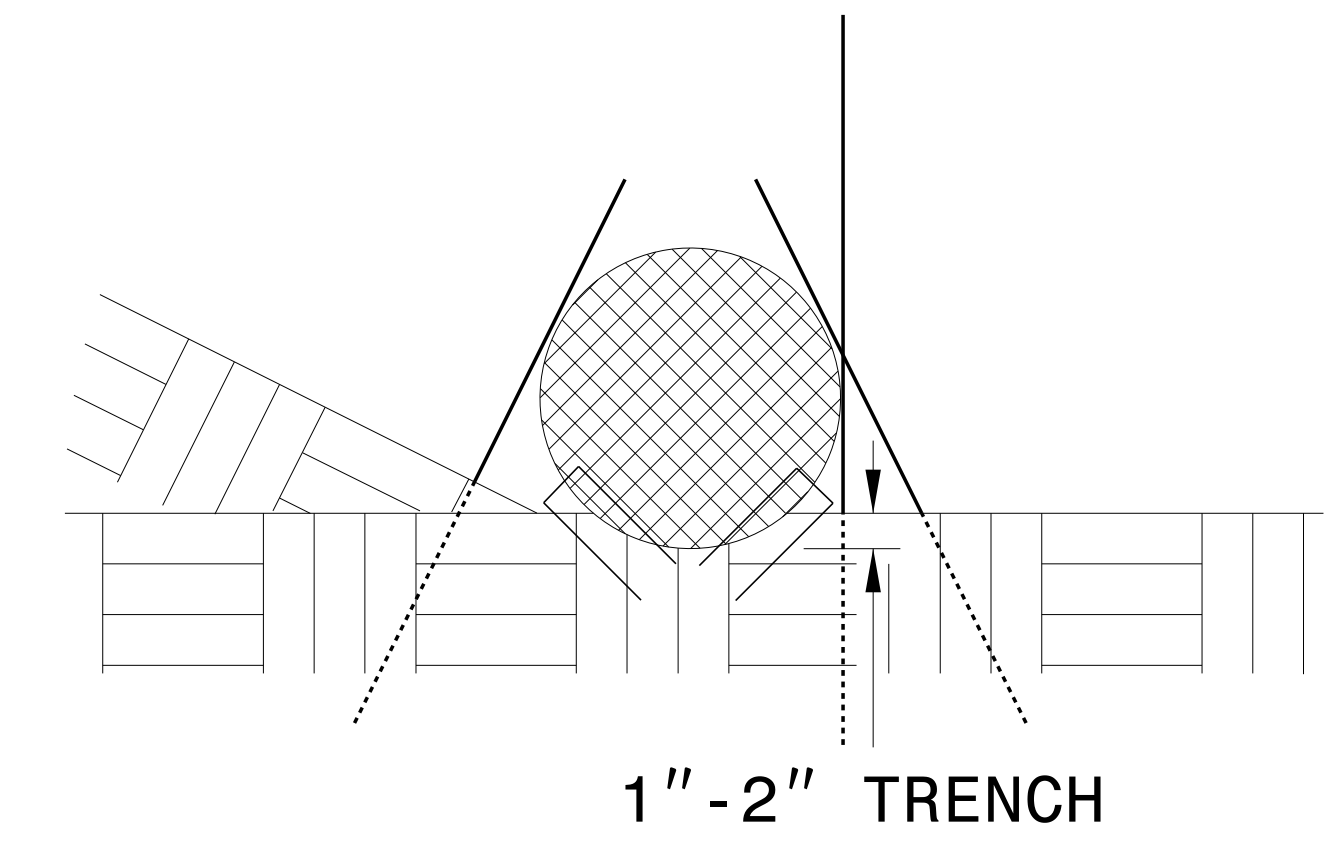

VIEW FROM SLOPE

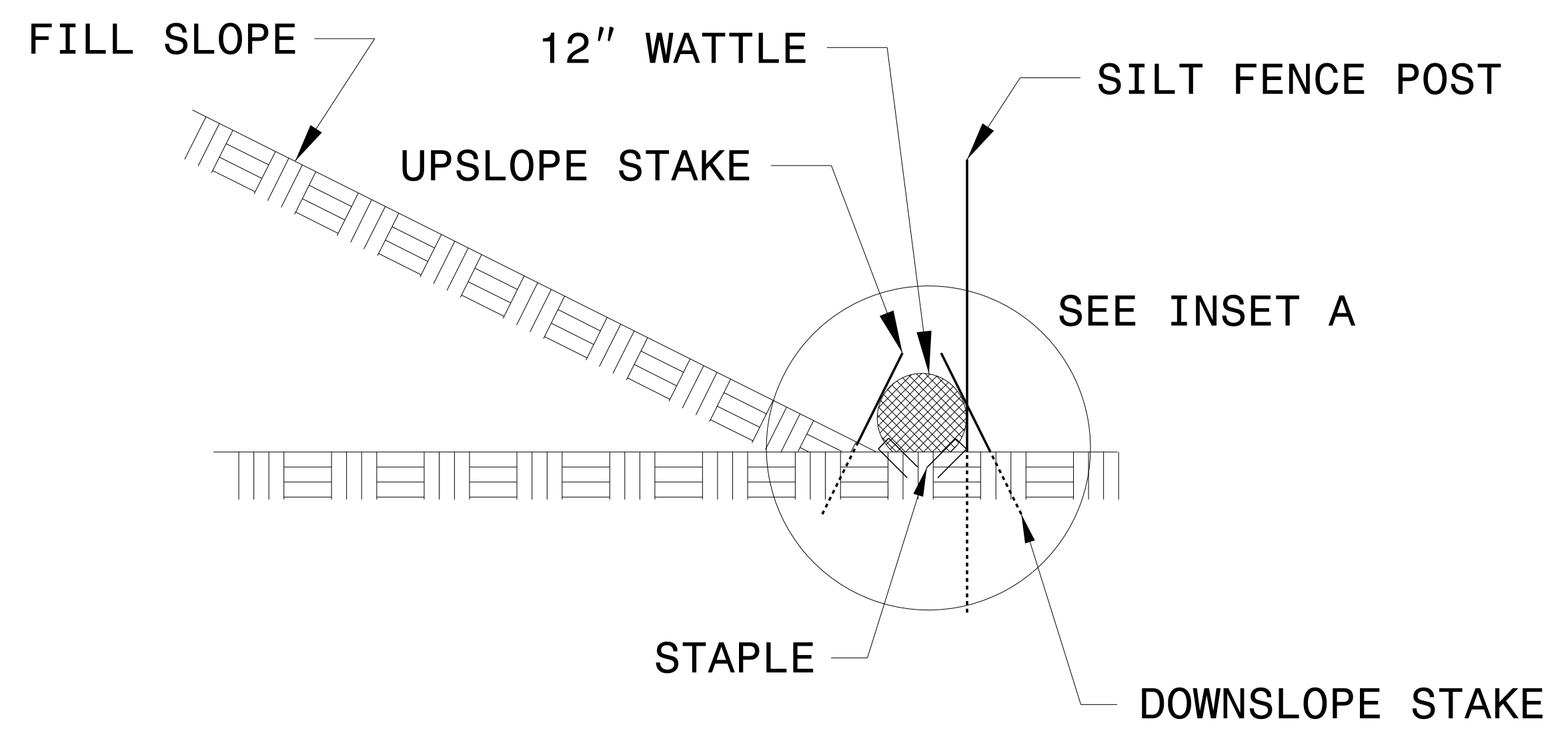

SIDE VIEW

DIVISION OF HIGHWAYS
STATE OF NORTH CAROLINA

PROJECT REFERENCE NO. <i>R-5013</i>	SHEET NO. <i>EC-3</i>
ROADWAY DESIGN ENGINEER	HYDRAULICS ENGINEER

SOIL STABILIZATION TIMEFRAMES

<i>SITE DESCRIPTION</i>	<i>STABILIZATION TIME</i>	<i>TIMEFRAME EXCEPTIONS</i>
PERIMETER DIKES, SWALES, DITCHES AND SLOPES	7 DAYS	NONE
HIGH QUALITY WATER (HQW) ZONES	7 DAYS	NONE
SLOPES STEEPER THAN 3:1	7 DAYS	IF SLOPES ARE 10' OR LESS IN LENGTH AND ARE NOT STEEPER THAN 2:1, 14 DAYS ARE ALLOWED.
SLOPES 3:1 OR FLATTER	14 DAYS	7 DAYS FOR SLOPES GREATER THAN 50' IN LENGTH.
ALL OTHER AREAS WITH SLOPES FLATTER THAN 4:1	14 DAYS	NONE, EXCEPT FOR PERIMETERS AND HQW ZONES.

PROJECT REFERENCE NO. R-5013	SHEET NO. EC-4/CONST.4
RW SHEET NO. ROADWAY DESIGN ENGINEER	HYDRAULICS ENGINEER

CLEARING AND GRUBBING
EROSION CONTROL FOR
CONSTRUCTION SHEET 4

NOTE:
PLACE TEMPORARY ROCK SEDIMENT DAMS TYPE - B
AND TEMPORARY ROCK SILT CHECKS TYPE - A AT
DRAINAGE OUTLETS.

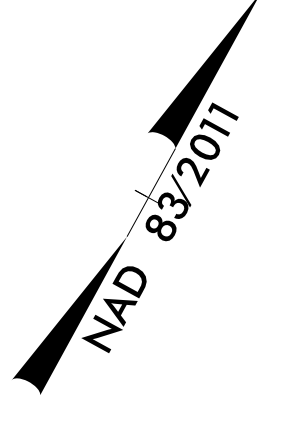

8/17/99

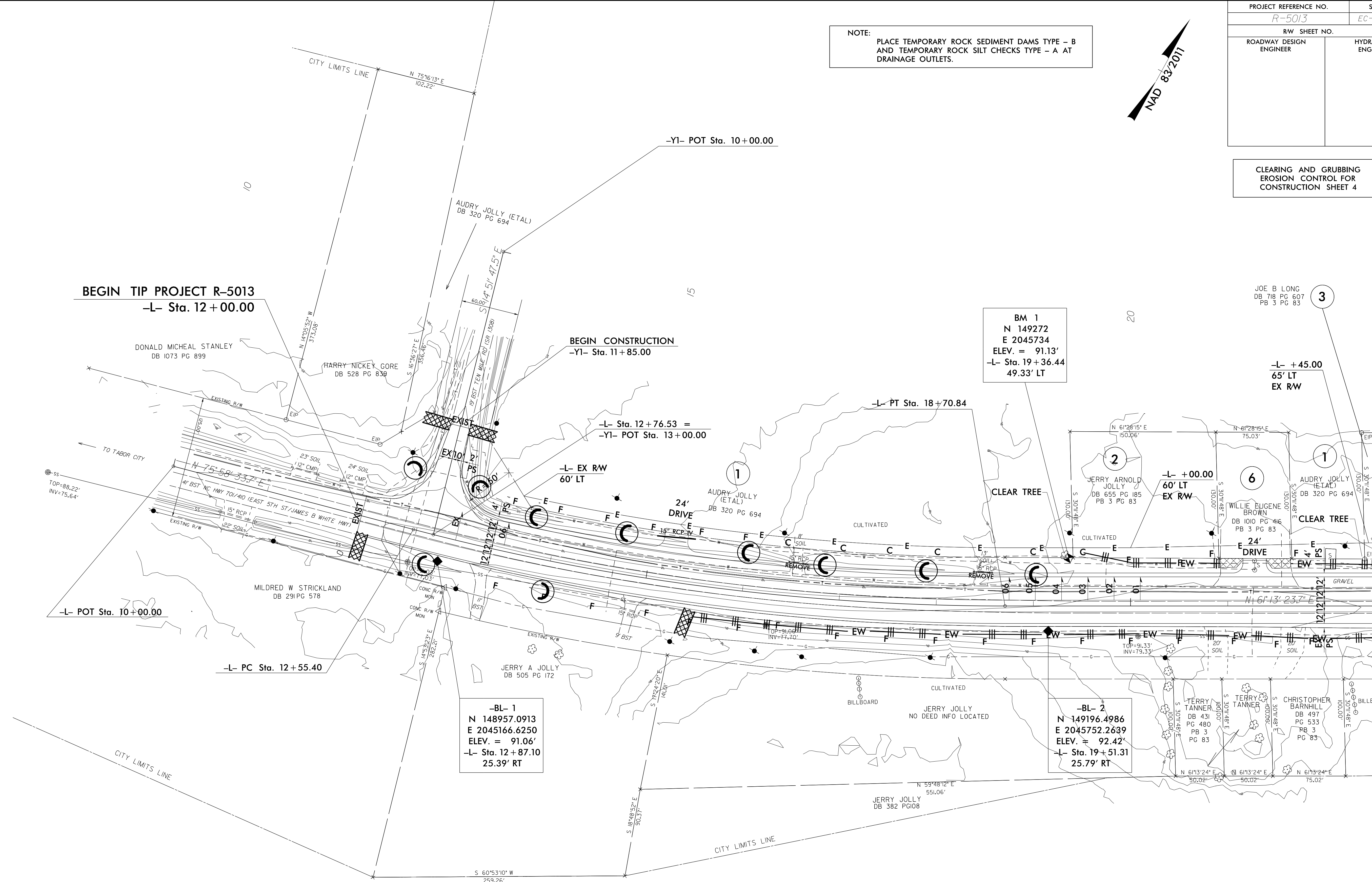

BEGIN TIP PROJECT R-5013
-L- Sta. 12+00.00

BEGIN CONSTRUCTION
-Y1- Sta. 11+85.00

BM 1
N 149272
E 2045734
ELEV. = 91.13'
-L- Sta. 19+36.44
49.33' LT

-BL- 1
N 148957.0913
E 2045166.6250
ELEV. = 91.06'
-L- Sta. 12+87.10
25.39' RT

-BL- 2
N 149196.4986
E 2045752.2639
ELEV. = 92.42'
-L- Sta. 19+51.31
25.79' RT

MATCH LINE SHEET 5 -L- Sta. 22+50.00

8/17/99

PROJECT REFERENCE NO. R-5013	SHEET NO. EC-5/CONST.5
RW SHEET NO.	
ROADWAY DESIGN ENGINEER	HYDRAULICS ENGINEER

CLEARING AND GRUBBING
EROSION CONTROL FOR
CONSTRUCTION SHEET 5

NOTE:
PLACE TEMPORARY ROCK SEDIMENT DAMS TYPE - B
AND TEMPORARY ROCK SILT CHECKS TYPE - A AT
DRAINAGE OUTLETS.

END TIP PROJECT R-5013
-L- Sta. 32 + 40.00

MATCH LINE SHEET 4 -L- Sta. 22 + 50.00

8/17/99

8/17/99

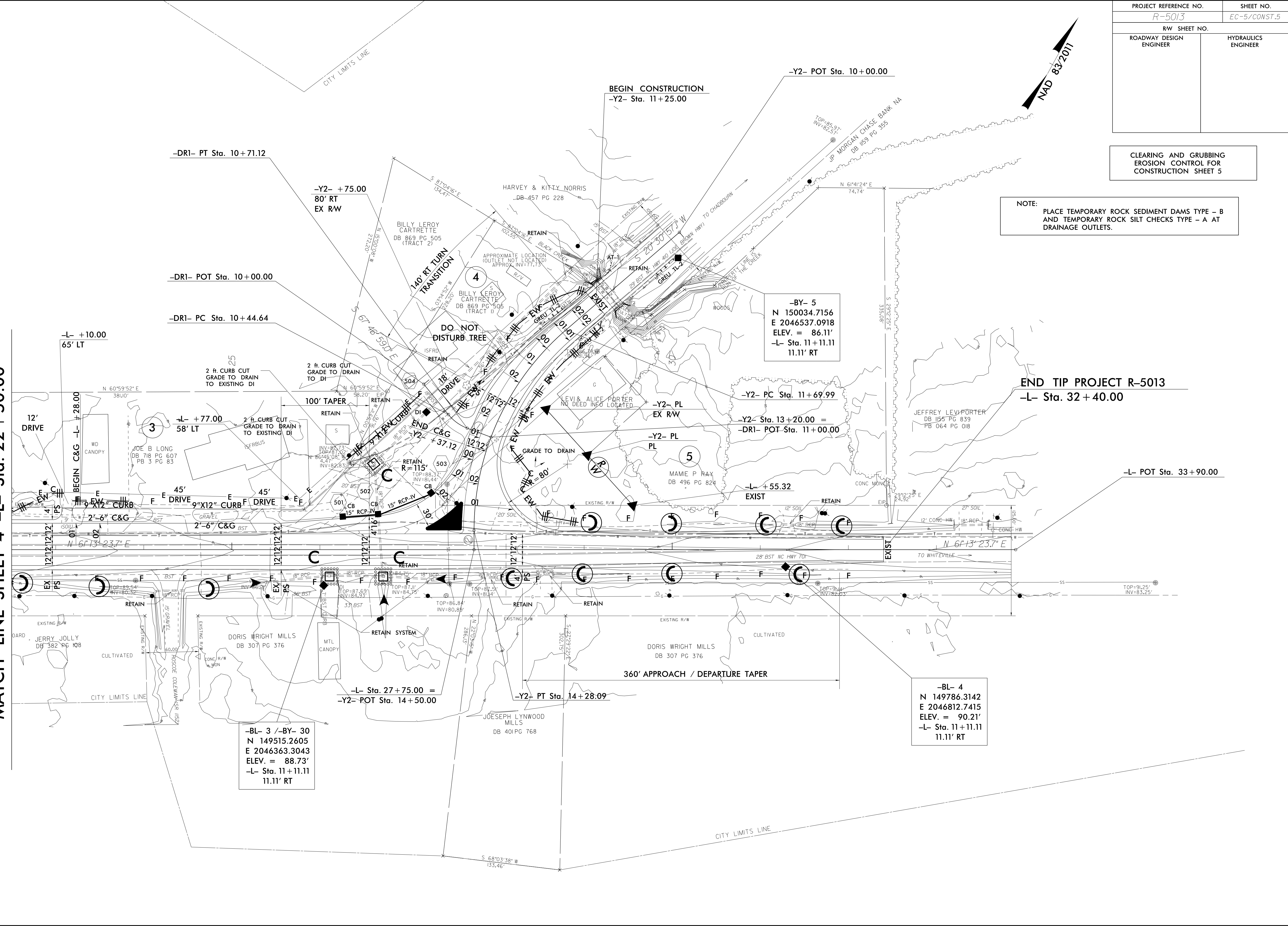

PROJECT REFERENCE NO. R-5013	SHEET NO. EC-6/CONST.4
RW SHEET NO. ROADWAY DESIGN ENGINEER	HYDRAULICS ENGINEER

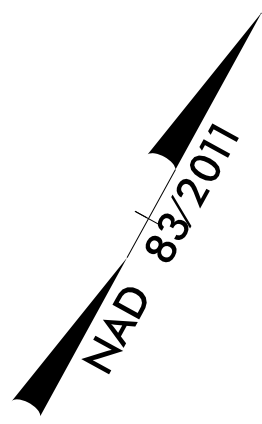

8/17/99

8/17/99

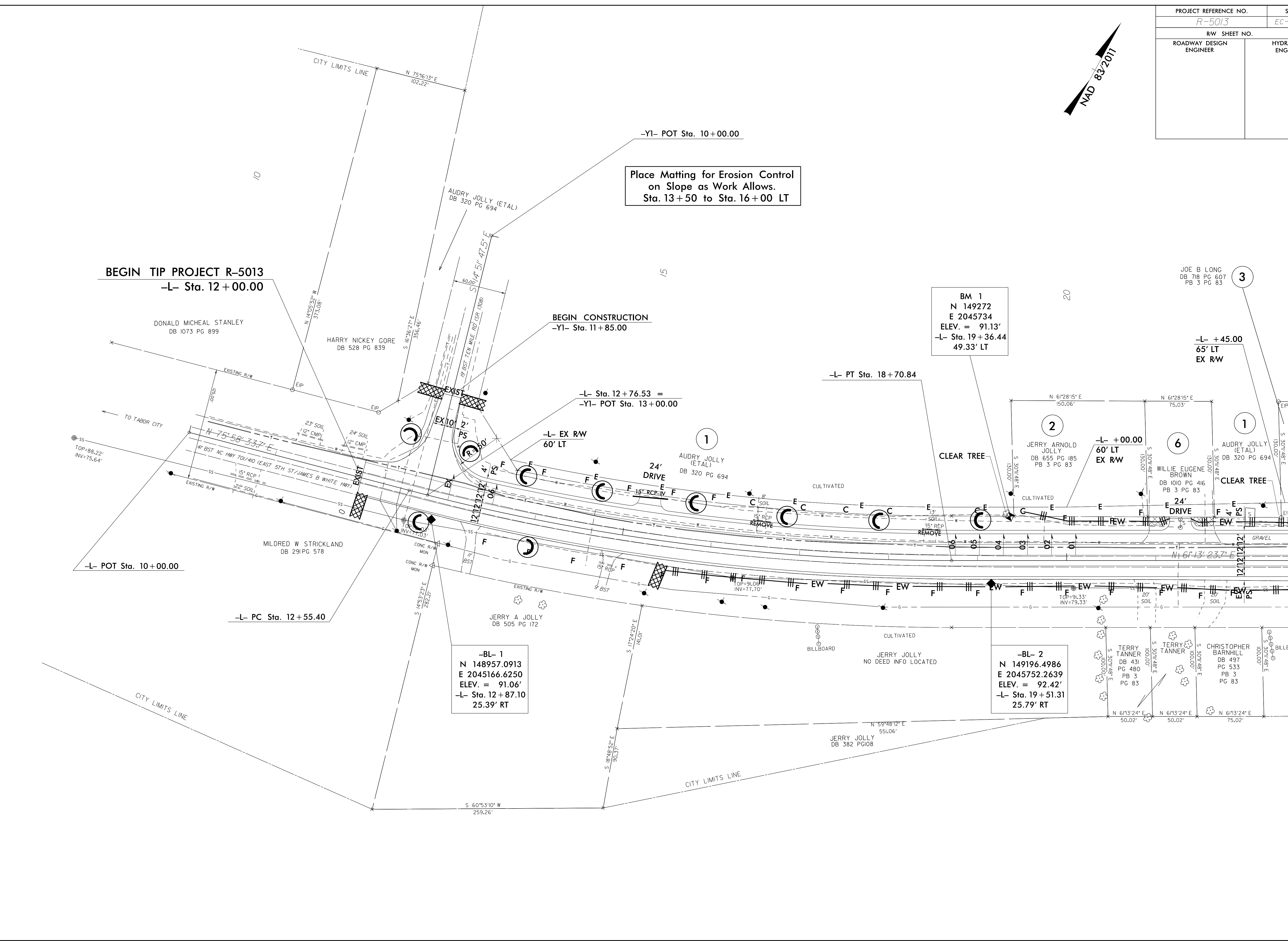

Place Matting for Erosion Control
on Slope as Work Allows.
Sta. 13+50 to Sta. 16+00 LT

BEGIN TIP PROJECT R-5013
-L- Sta. 12+00.00

BEGIN CONSTRUCTION
-Y1- Sta. 11+85.00

BM 1
N 149272
E 2045734
ELEV. = 91.13'
-L- Sta. 19+36.44
49.33' LT

-BL- 1
N 148957.0913
E 2045166.6250
ELEV. = 91.06'
-L- Sta. 12+87.10
25.39' RT

-BL- 2
N 149196.4986
E 2045752.2639
ELEV. = 92.42'
-L- Sta. 19+51.31
25.79' RT

MATCH LINE SHEET 5 -L- Sta. 22+50.00

PROJECT REFERENCE NO. R-5013	SHEET NO. EC-7/CONST.5
RW SHEET NO. ROADWAY DESIGN ENGINEER	HYDRAULICS ENGINEER

Place Matting for Erosion Control
on Slope as Work Allows.
-Y2- Sta. 11+50 to Sta. 12+50 RT

MATCH LINE SHEET 4 -L- Sta. 22 + 50.00

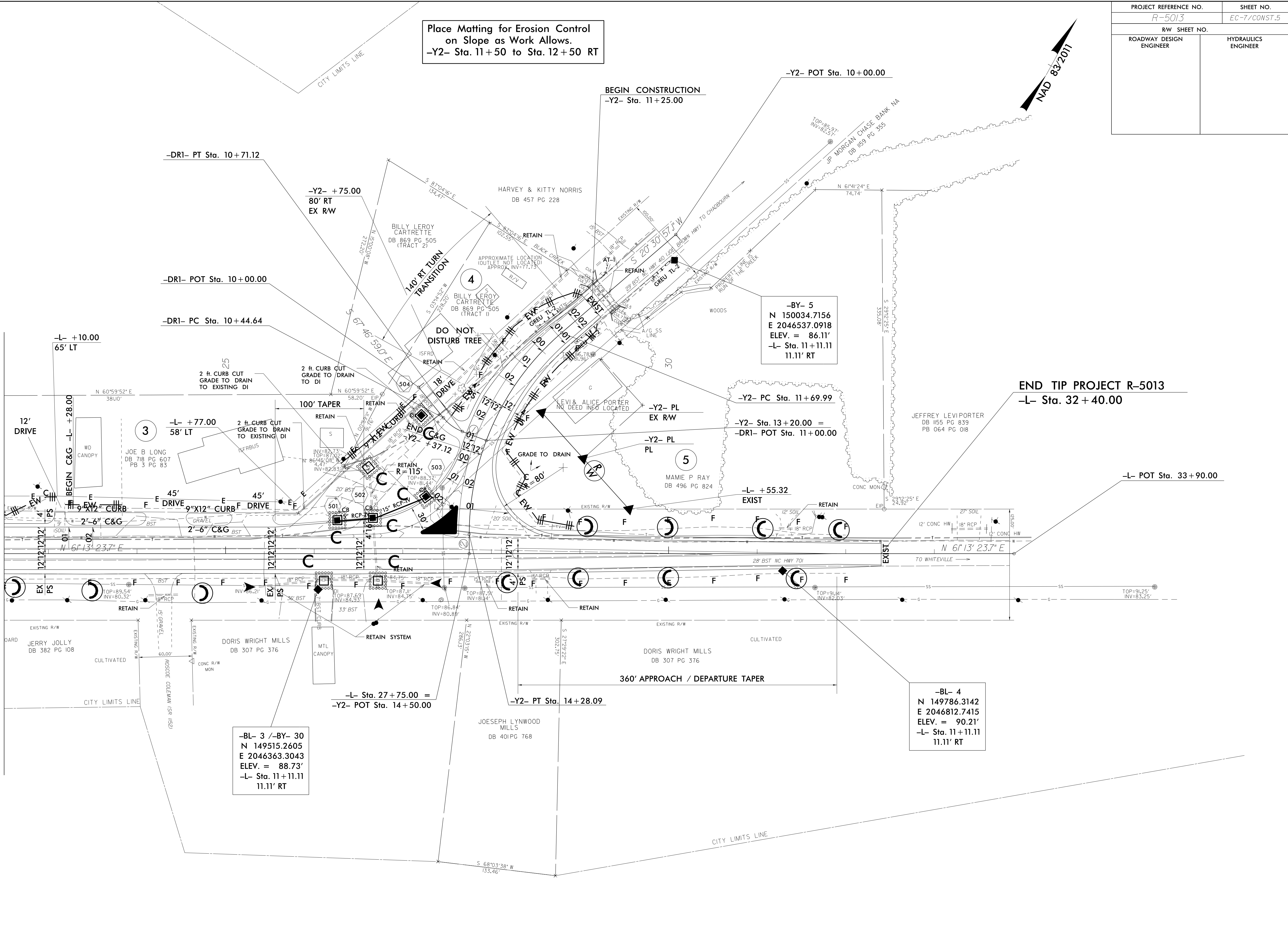

-BY- 5
N 150034.7156
E 2046537.0918
ELEV. = 86.11'
-L- Sta. 11+11.11
11.11' RT

-BL- 4
N 149786.3142
E 2046812.7415
ELEV. = 90.21'
-L- Sta. 11+11.11
11.11' RT

-BL- 3 /-BY- 30
N 149515.2605
E 2046363.3043
ELEV. = 88.73'
-L- Sta. 11+11.11
11.11' RT

END TIP PROJECT R-5013
-L- Sta. 32 + 40.00

8/17/99

T.I.P.: R-5013

CONTRACT:

**STATE OF NORTH CAROLINA
DEPARTMENT OF TRANSPORTATION**

**SIGNING PLAN
COLUMBUS COUNTY**

**LOCATION: US 70/NC 410 (JAMES B WHITE HIGHWAY/EAST
FIFTH STREET) AT NC 410 (JOE BROWN HIGHWAY)**

TIP NO. R-5013	SHEET NO. SIGN - 1
Approved by: <i>Hyman Alqudwah</i>	
DATE: 5/8/2019	
SEAL	
	

ROADWAY STANDARD DRAWING

THE FOLLOWING ROADWAY STANDARDS AS APPEAR IN "ROADWAY STANDARD DRAWINGS" - PROJECT SERVICES UNIT - N.C. DEPARTMENT OF TRANSPORTATION - RALEIGH, N.C., DATED JANUARY 2018 ARE APPLICABLE TO THIS PROJECT AND BY REFERENCE HEREBY ARE CONSIDERED A PART OF THESE PLANS:

STD. NO.	TITLE
904.10	ORIENTATION OF GROUND MOUNTED SIGNS
904.50	MOUNTING OF TYPE 'D', 'E' AND 'F' SIGNS ON 'U' CHANNEL POSTS

GENERAL NOTES

- SIGNS FURNISHED BY STATE
- CONFIRM IN WRITING AT LEAST 4 MONTHS IN ADVANCE, THE ACTUAL DATE THE DEPARTMENT FURNISHED SIGNS WILL BE REQUIRED.
- ALL TYPE 'D' SIGNS SHALL BE MOUNTED ON TWO U-CHANNEL POSTS UNLESS OTHERWISE INDICATED ON THE PLANS.
- WHEN NOT STATIONED OR DIMENSIONED ON PLANS, ALL 'E' AND 'F' SIGNS SHALL BE FIELD LOCATED BY THE ENGINEER
- ALL EXISTING SIGNS ON "U" CHANNEL POST WITHIN THE PROJECT LIMITS SHALL BE REMOVED AND DISPOSED OF UNLESS OTHERWISE NOTED ON PLANS.
- WHEN EXISTING SIGNS ARE REMOVED AND INSTALLED ON NEW SUPPORTS, THE RE-ERECTION SHALL IMMEDIATELY FOLLOW THE REMOVAL.
- THE BACKGROUND FOR TYPE E & F SIGNS SHALL BE TYPE C REFLECTIVE SHEETING.

SUMMARY OF QUANTITIES

ITEM NO.		ITEM DESCRIPTION	QUANTITY	UNIT
DESC. NO.	SECT. NO.			
4072000000	903	SUPPORTS, 3 LB STEEL U-CHANNEL	395	L.F.
4096000000	904	SIGN ERECTION, TYPE D	3	EA.
4102000000	904	SIGN ERECTION, TYPE E	5	EA.
4108000000	904	SIGN ERECTION, TYPE F	7	EA.
4155000000	907	DISPOSAL OF SIGN SYSTEM, U-CHANNEL	10	EA.

INDEX

SHEET NO.	DESCRIPTION
SIGN-1	TITLE SHEET
SIGN-2	TYPE E AND F SIGNS
SIGN-3	SIGN DESIGNS
SIGN-4-5	EXISTING AND PROPOSED SIGNS

PLAN REVIEWED BY: N.C.D.O.T. SIGNING AND DELINEATION UNIT

A. ALQUDWAH, PE SIGNING & DELINEATION REGIONAL ENGINEER
M. TRACEY, PE SIGNING & DELINEATION PROJECT DESIGN ENGINEER

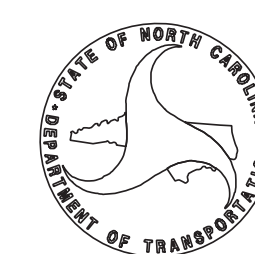

401 QUANTITY REQ'D 2

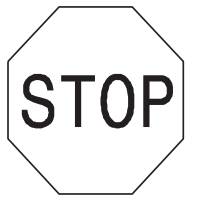

36" X 36"
R1-1

ONE "U" POST PER SIGN

402 QUANTITY REQ'D 2

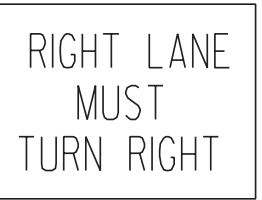

36" X 36"
R3-7

ONE "U" POST PER SIGN

403 QUANTITY REQ'D 1

SIGN DETAIL
SCALE 1:30

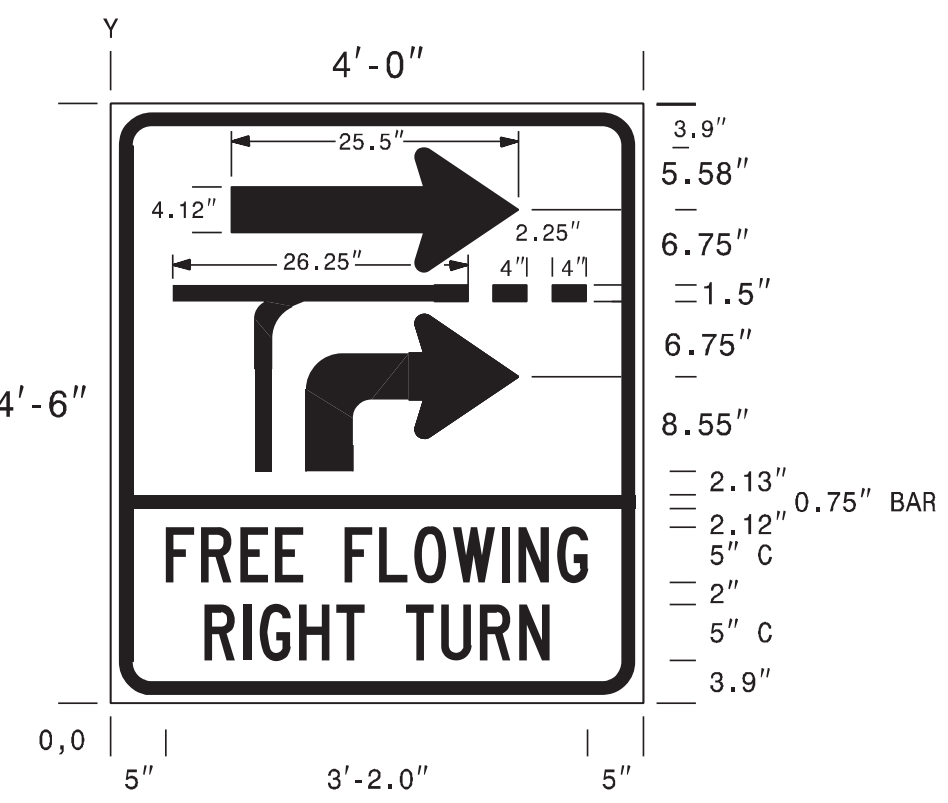

N. C. DEPARTMENT OF TRANSPORTATION
DIVISION OF HIGHWAYS
TRAFFIC ENGINEERING BRANCH

SIGN NUMBER: 403 DESIGN BY: MB ALLEN DATE: 7/21/03
 TYPE: E CHECKED BY: STD. #10
 QUANTITY: PROJECT ID: DIV:
 WIDTH X HEIGHT: 48" x 54" BACKGROUND COLOR: YELLOW
 SIGN AREA: 18.00 SQ. FT. COPY COLOR: BLACK
 BORDER TYPE: RECESS MAJ COPY SERIES: C
 RECESS: 0.75"
 BORDER WIDTH: 1.25" 2 U CHANNEL POST(S)
 RADII: 3.0" MAT'L: 0.125" ALUMINUM

NOTES:
 -Legend and border shall be direct applied non-reflective sheeting.
 -Background shall be Grade C reflective sheeting.

DIMENSIONS IN INCHES SPACINGS ARE TO START OF NEXT LETTER

Y FONT	LETTER SPACINGS														HT LEN	
10.9 C	F	R	E	E	F	L	O	W	I	N	G					5.0
	5.0	3.1	3.5	3.1	2.5	3.8	3.1	3.1	3.5	4.4	1.5	3.5	2.7	5.0	38.0	
3.9 C	R	I	G	H	T	T	U	R	N						5.0	
	8.5	3.5	1.5	3.5	3.4	2.5	3.8	3.1	3.5	3.5	2.7	8.5			31.1	

501

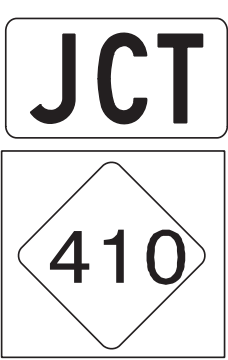

1 - 21" X 15"
1 - 24" X 24"

ONE "U" POST PER SIGN

506

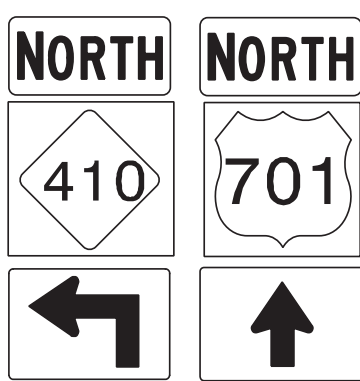

2 - 24" X 12"
2 - 24" X 24"
2 - 21" X 15"

502



1 - 24" X 12"
1 - 24" X 24"

ONE "U" POST PER SIGN

507

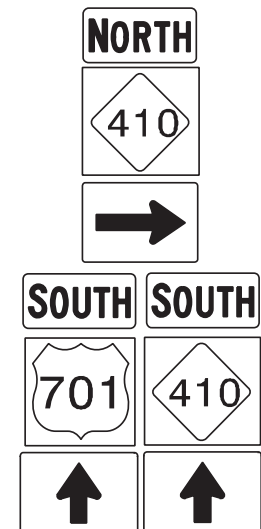

1 - 24" X 12"
1 - 24" X 24"
1 - 21" X 15"
2 - 24" X 12"
2 - 24" X 24"
2 - 21" X 15"

503

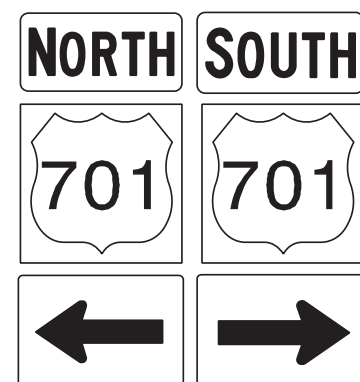

2 - 24" X 12"
2 - 24" X 24"
2 - 21" X 15"

ONE "U" POST PER SIGN

504

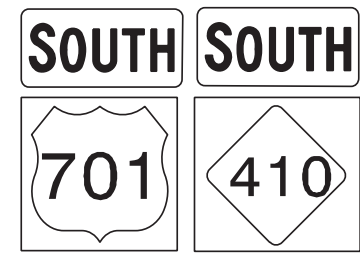

2 - 24" X 12"
2 - 24" X 24"

TWO "U" POSTS PER SIGN

505



2 - 24" X 12"
2 - 24" X 24"
2 - 21" X 15"

TIP NO. SHEET NO.
 028018 SIGN-2

APPROVED: *Ayman Alqudwah*
 DATE: 5/8/2019

SEAL



TYPE "E" AND "F" SIGNS

C:\Users\user\Documents\Projects\Traffic\Signing\CADD\Signing_Layout_Plans\2018_PEF_Engseed_07-16-18.dgn
 User: user

TIP NO.	SHEET NO.
DESIGNED BY	SIGN-3
APPROVED BY <i>Abdullah Alqudwah</i>	
DATE: 5/8/2019	
SEAL	

SIGN NUMBER: 302
TYPE: D
QUANTITY: 1
SIGN WIDTH: 6'-0"
HEIGHT: 3'-6"
TOTAL AREA: 21.0 Sq.Ft.

BACKG COLOR: Green
COPY COLOR: White

SYMBOL	X	Y	WID	HT
AR_Type D	56.9	18	6	9

MAT'L: 0.125" (3.2 mm) ALUMINUM

DESIGN BY: M. TRACEY
PROJECT ID:
CHECKED BY:
LOCATION:
Jan 09, 2019
DIV: 6

BORDER R=3" TH=0.75"

USE NOTES: 1,2
1. Legend and border(except those that are colored black) shall be direct applied Grade C sheeting.
2. Background shall be Grade C reflective sheeting.

LETTER POSITIONS

Letter spacings are to start of next letter

	T	a	b	o	r	C	i	t	y		Series/Size				
	6.1	4.2	4.6	4.3	4.6	2.3	5	5.3	1.6	2.6	4.5	27	D 2000		
													39		
	L	o	r	i	s								D 2000		
	6.1	4.3	4.6	3	1.8	2.8	49.4						16.5		
	M	y	r	t	l	e	B	e	a	c	h		D 2000		
	6.1	5.3	5	2.4	2.9	1.6	3.5	5	4.5	3.9	4	4.1	3.5	20.1	45.8

FILENAME: Sign Designs

NORTH CAROLINA D.O.T. SIGN DETAIL

SIGN NUMBER: 303
TYPE: D
QUANTITY: 1
SIGN WIDTH: 7'-0"
HEIGHT: 2'-0"
TOTAL AREA: 14.0 Sq.Ft.

BACKG COLOR: Green
COPY COLOR: White

SYMBOL	X	Y	WID	HT
AR_Type D	9.4	8	8	12

MAT'L: 0.125" (3.2 mm) ALUMINUM

DESIGN BY: M. TRACEY
PROJECT ID:
CHECKED BY:
LOCATION:
Feb 04, 2019
DIV: 6

BORDER R=3" TH=1"

USE NOTES: 1,2
1. Legend and border(except those that are colored black) shall be direct applied Grade C sheeting.
2. Background shall be Grade C reflective sheeting.

LETTER POSITIONS

Letter spacings are to start of next letter

	W	h	i	t	e	v	i	l	e		Series/Size		
	29.4	8.2	6.2	2.2	3.8	5.2	6.6	2.9	2.9	2.6	4.7	9.4	D 2000
													45.2

FILENAME: Sign Designs

NORTH CAROLINA D.O.T. SIGN DETAIL

SIGN NUMBER: 301
TYPE: D
QUANTITY: 1
SIGN WIDTH: 6'-6"
HEIGHT: 2'-6"
TOTAL AREA: 13.8 Sq.Ft.

BACKG COLOR: Green
COPY COLOR: White

SYMBOL	X	Y	WID	HT
AR_Type D	10	17	6	9
AR_Type D	6	4	6	9

MAT'L: 0.125" (3.2 mm) ALUMINUM

DESIGN BY: M. TRACEY
PROJECT ID: R-5013
CHECKED BY:
LOCATION:
Jan 02, 2019
DIV: 6

BORDER R=3" TH=0.75"

USE NOTES: 1,2
1. Legend and border(except those that are colored black) shall be direct applied Grade C sheeting.
2. Background shall be Grade C reflective sheeting.

LETTER POSITIONS

Letter spacings are to start of next letter

	W	h	i	t	e	v	i	l	e		Series/Size		
	22.1	6.1	4.7	1.6	2.8	3.9	5	2.2	2.2	1.9	3.5	10.1	D 2000
													33.9
	C <td>h <td>a <td>d <td>b <td>o <td>u <td>r <td>n <td></td> <td></td> <td></td> <td>D 2000</td> </td></td></td></td></td></td></td></td>	h <td>a <td>d <td>b <td>o <td>u <td>r <td>n <td></td> <td></td> <td></td> <td>D 2000</td> </td></td></td></td></td></td></td>	a <td>d <td>b <td>o <td>u <td>r <td>n <td></td> <td></td> <td></td> <td>D 2000</td> </td></td></td></td></td></td>	d <td>b <td>o <td>u <td>r <td>n <td></td> <td></td> <td></td> <td>D 2000</td> </td></td></td></td></td>	b <td>o <td>u <td>r <td>n <td></td> <td></td> <td></td> <td>D 2000</td> </td></td></td></td>	o <td>u <td>r <td>n <td></td> <td></td> <td></td> <td>D 2000</td> </td></td></td>	u <td>r <td>n <td></td> <td></td> <td></td> <td>D 2000</td> </td></td>	r <td>n <td></td> <td></td> <td></td> <td>D 2000</td> </td>	n <td></td> <td></td> <td></td> <td>D 2000</td>				D 2000
	21	5.3	4.4	4.3	4.8	4.3	4.6	4.7	3	3.5	6		38.9

FILENAME: Sign Designs

NORTH CAROLINA D.O.T. SIGN DETAIL

SIGN DESIGNS

C:\Users\mtracy\Documents\Projects\Sign Design\Sign Designs.dgn

TIP NO. B-5230.1(2) 17	SHEET NO. SIGN-4
APPROVED: <i>Thomas Harman</i>	
DATE: 5/8/2019	
SEAL	

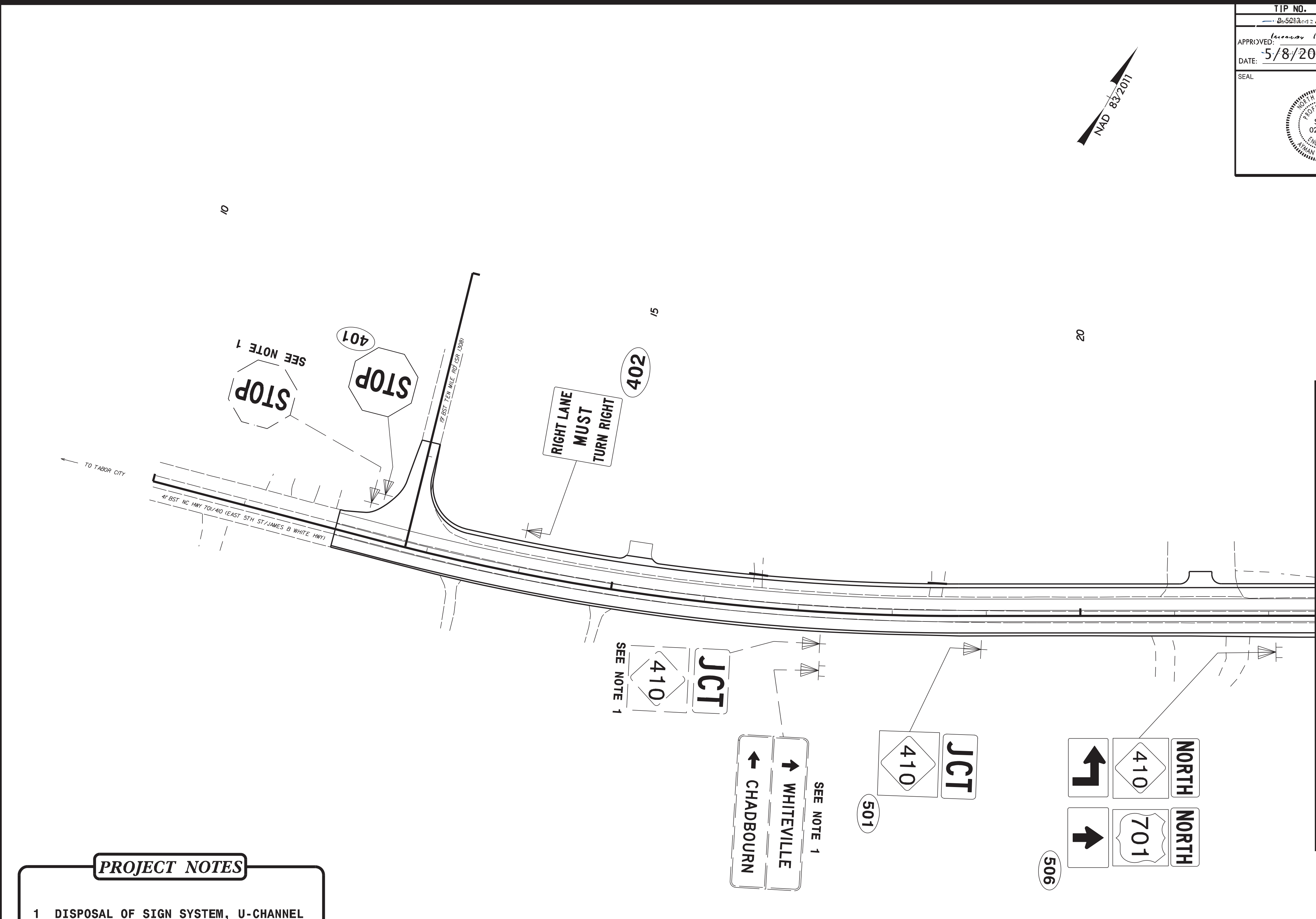
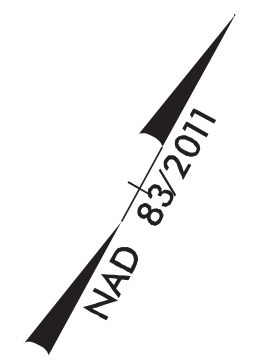

PROJECT NOTES

1 DISPOSAL OF SIGN SYSTEM, U-CHANNEL

EXISTING AND PROPOSED SIGNS

C:\Users\58013\OneDrive\Documents\Projects\Traffic\Signing\CADD\Signing_Layout_Plans\58013_sgn_03.dgn
 User: 58013

PROJECT REFERENCE NO.	SHEET NO.
R-5013	UC-1

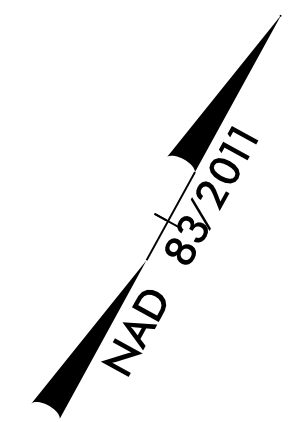

8/17/99

REVISIONS

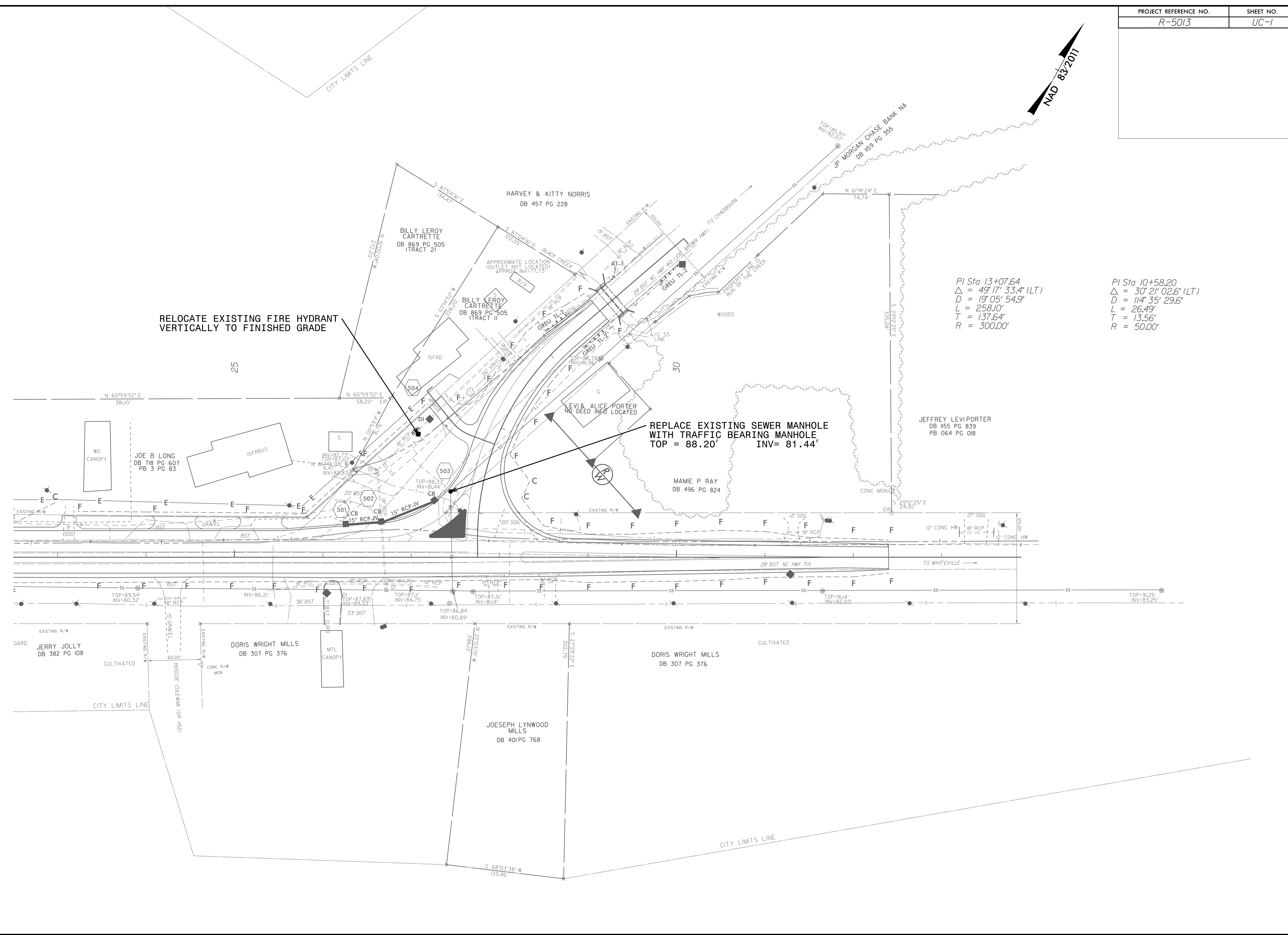

PI Sta 13+07.64
 $\Delta = 49^{\circ} 17' 33.4''$ (LT)
 $D = 19^{\circ} 05' 54.9''$
 $L = 258.10'$
 $T = 137.64'$
 $R = 300.00'$

PI Sta 10+58.20
 $\Delta = 30^{\circ} 21' 02.6''$ (LT)
 $D = 114^{\circ} 35' 29.6''$
 $L = 26.49'$
 $T = 13.56'$
 $R = 50.00'$

23 MAY 2019 09:53 P=5013 US 701 at NC 410\Utility\Des\Design\R-5013_U.L.tsb_UCL.tsb.dgn
 9:53 AM
 8/17/99

