

TIP NO. SHEET NO.
 DocuSigned by:
 APPROVED: *Matthew V. Springer*
 DATE: 8/13/2019
 SEAL

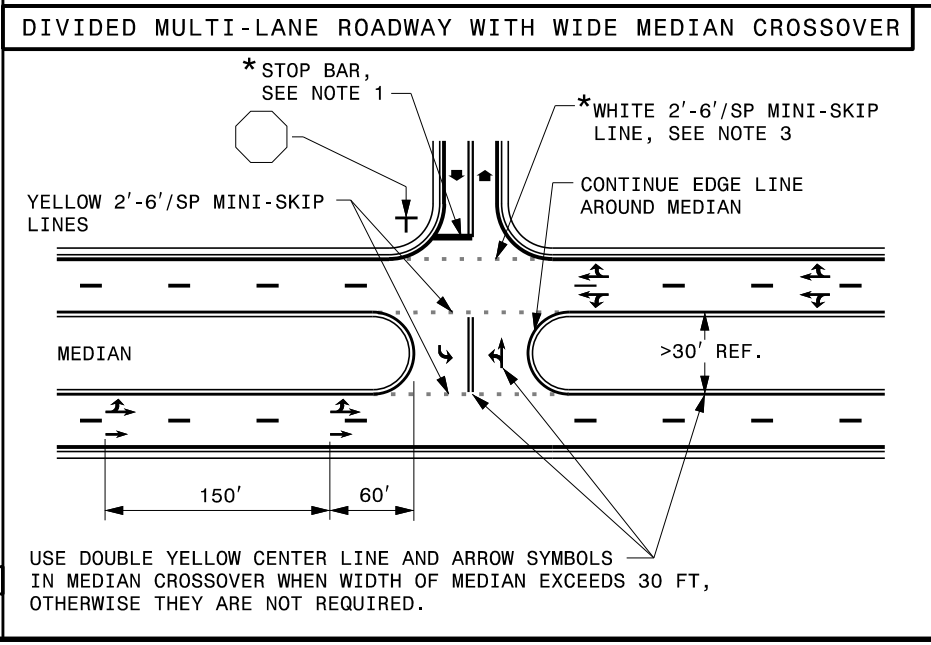

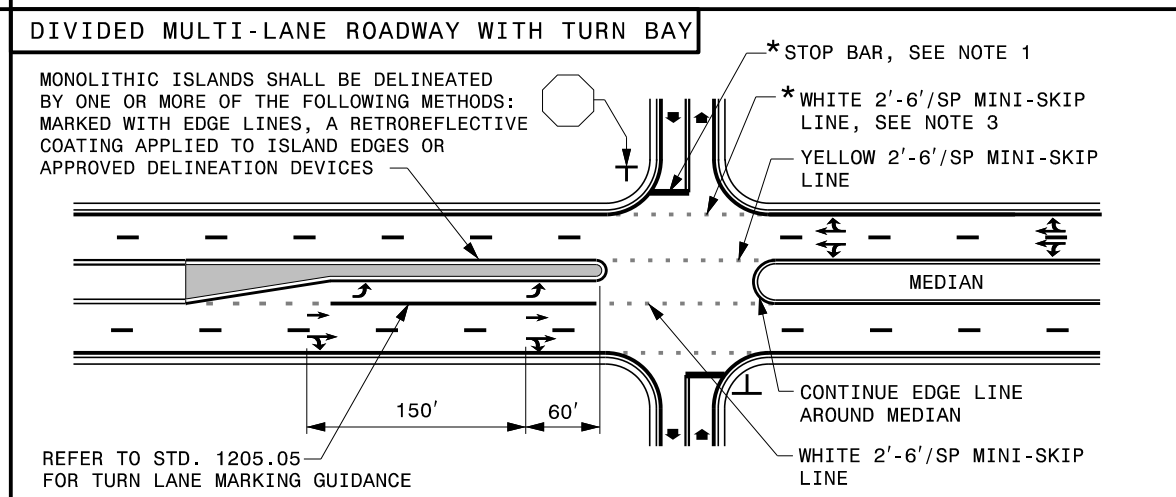

STATE OF NORTH CAROLINA
 DEPT. OF TRANSPORTATION
 DIVISION OF HIGHWAYS
 RALEIGH, N.C.
 8-19
 ENGLISH DETAIL DRAWING FOR
PAVEMENT MARKINGS
 INTERSECTIONS
 SHEET 2 OF 2
1205D04

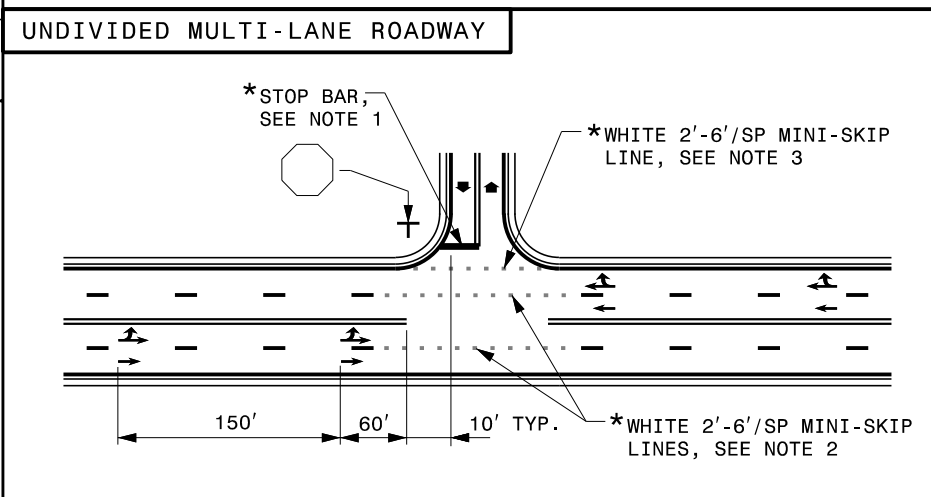
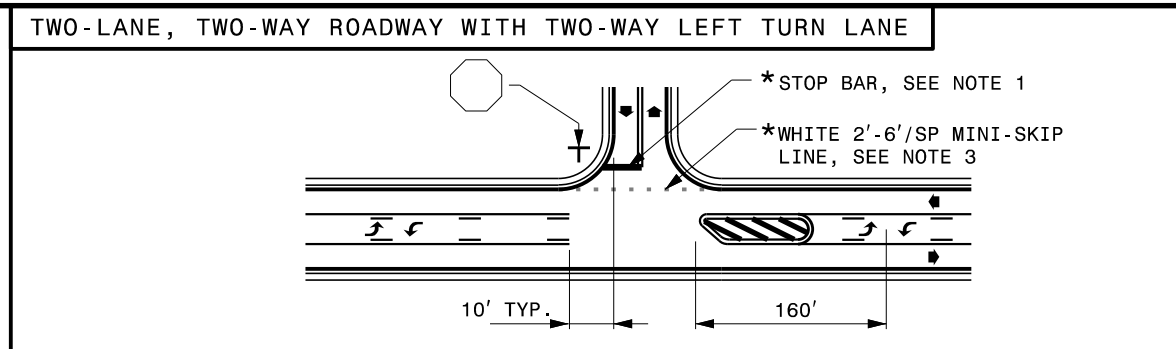
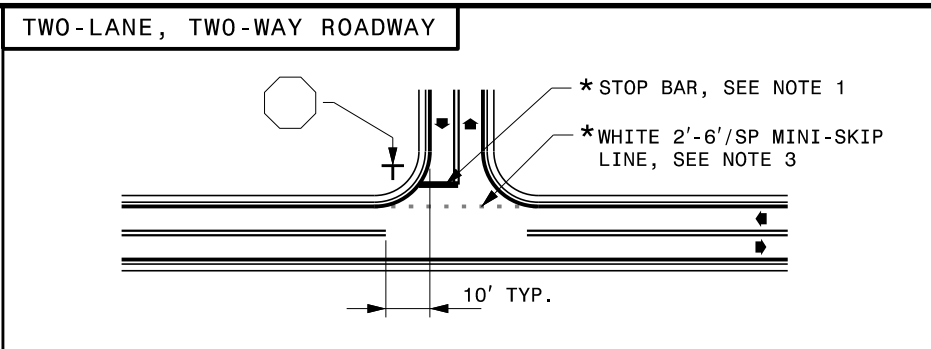

GENERAL NOTES:

- 1- PLACEMENT OF STOP BARS AT NON-SIGNALIZED INTERSECTIONS IS OPTIONAL AND USED WHERE IT IS IMPORTANT TO INDICATE THE POINT WHICH VEHICLES ARE REQUIRED TO STOP. PLACE STOP BARS NO LESS THAN 4 FEET AND NO MORE THAN 30 FEET FROM THE NEAREST EDGE OF THE INTERSECTING ROADWAY. USE 10 FEET AS THE TYPICAL SETBACK DISTANCE OR AS DIRECTED BY THE ENGINEER.
- 2- MINI-SKIP LANE LINE EXTENSIONS SHOULD BE USED AT INTERSECTIONS THAT HAVE REDUCED VISIBILITY CONDITIONS SUCH AS OFFSET, SKEWED, OR CURVED ROADWAYS.
- 3- MINI-SKIP EDGE LINE EXTENSIONS MAY BE PLACED THROUGH INTERSECTIONS AND MAJOR DRIVEWAYS.
- 4- REFER TO ROADWAY STANDARD DRAWINGS 1205.01, 1205.02, 1205.05, 1205.08 AND 1205.09 FOR ADDITIONAL PAVEMENT MARKING GUIDANCE.

LEGEND

 STOP SIGN	 STATIONARY SIGN
 DIRECTION OF TRAFFIC FLOW	 PAVEMENT MARKING SYMBOLS
* OPTIONAL	

SHEET 2 OF 2
1205D04

STATE OF NORTH CAROLINA
 DEPT. OF TRANSPORTATION
 DIVISION OF HIGHWAYS
 RALEIGH, N.C.
 8-19
 ENGLISH DETAIL DRAWING FOR
PAVEMENT MARKINGS
 INTERSECTIONS
 SHEET 2 OF 2
1205D04

REVISED PAVEMENT MARKING ROADWAY STANDARD DRAWING