

SECTION VIEW
(STRAND LAYOUT NOT SHOWN)

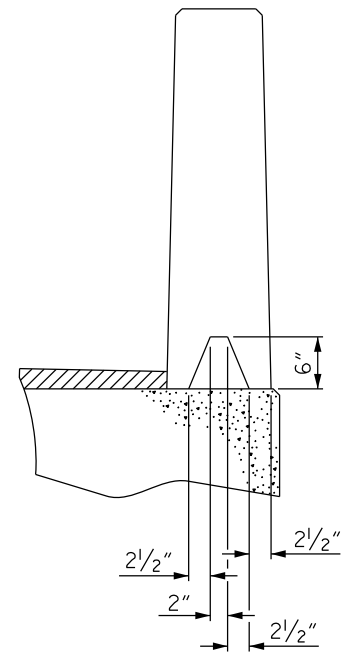

SECTION S-S
AT DAM IN OPEN JOINT
(THIS IS TO BE USED ONLY
WHEN SLIP FORM IS USED)

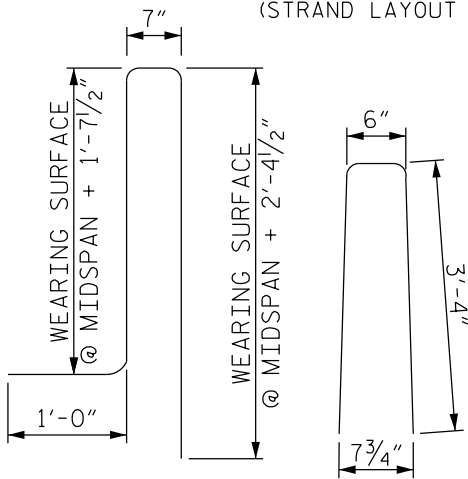

'S' BAR DETAILS

DIM. A = WEARING SURFACE @ MIDSPAN + 1'-3"

* DIMENSION = WEARING SURFACE @ MIDSPAN + 3'-6"

** DIMENSION = WEARING SURFACE @ C/BEARING + 3'-6"

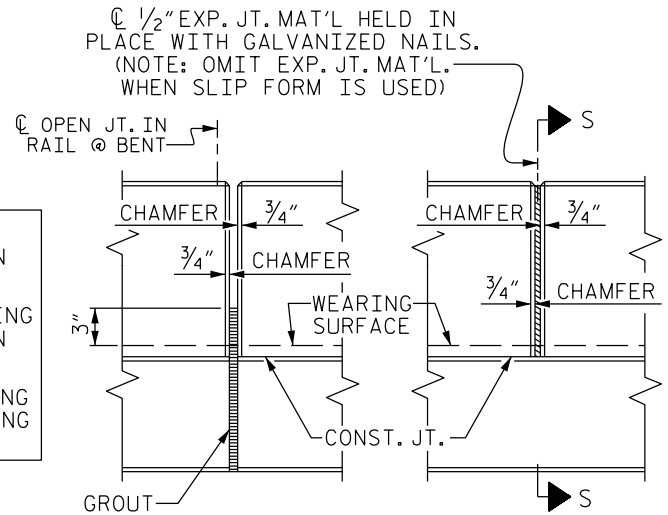

ELEVATION AT EXP. JTS.

NOTE TO DESIGNER:

WHEN THE WEARING SURFACE OR OVERLAY IS 3 1/2" OR GREATER PLACE AN ADDITIONAL PAIR OF "B" BARS 3" ABOVE THE TOP OF UNIT. IF DRAINS ARE ALSO REQUIRED ON THE STRUCTURE DETAIL 2" CLEAR TO THE DRAINS OR PLACE THIS NOTE ON PLANS:
THE BOTTOM TWO #5 "B" BARS IN THE VERTICAL CONCRETE BARRIER RAIL MAY BE FIELD CUT TO AVOID DRAINS.

#5 "S" BARS IN THE BARRIER RAIL TO BE SPACED AT 6" CTS. FOR 4'-0" EACH END OF UNIT AND AT 9" CTS. ELSEWHERE.

IF BRIDGE DECK DRAINS ARE REQUIRED ADD THE FOLLOWING NOTES TO THE PLANS:
THE DRAIN OPENING AT THE GUTTERLINE SHALL BE 4" X 5". THE HEIGHT OF THE BLOCKOUT IN THE VERTICAL CONCRETE BARRIER RAIL SHALL EXTEND FROM THE TOP OF THE BOX BEAM UNIT TO THE TOP OF THE DRAIN OPENING.

APPLY EPOXY PROTECTIVE COATING TO EXTERIOR FACE OF THE EXTERIOR BOX BEAM UNITS THAT REQUIRE DRAINS IN THE BARRIER RAIL.

VERTICAL CONCRETE BARRIER RAIL ON BOX BEAM

FIGURE 6 - 11