

LEVEL CAP

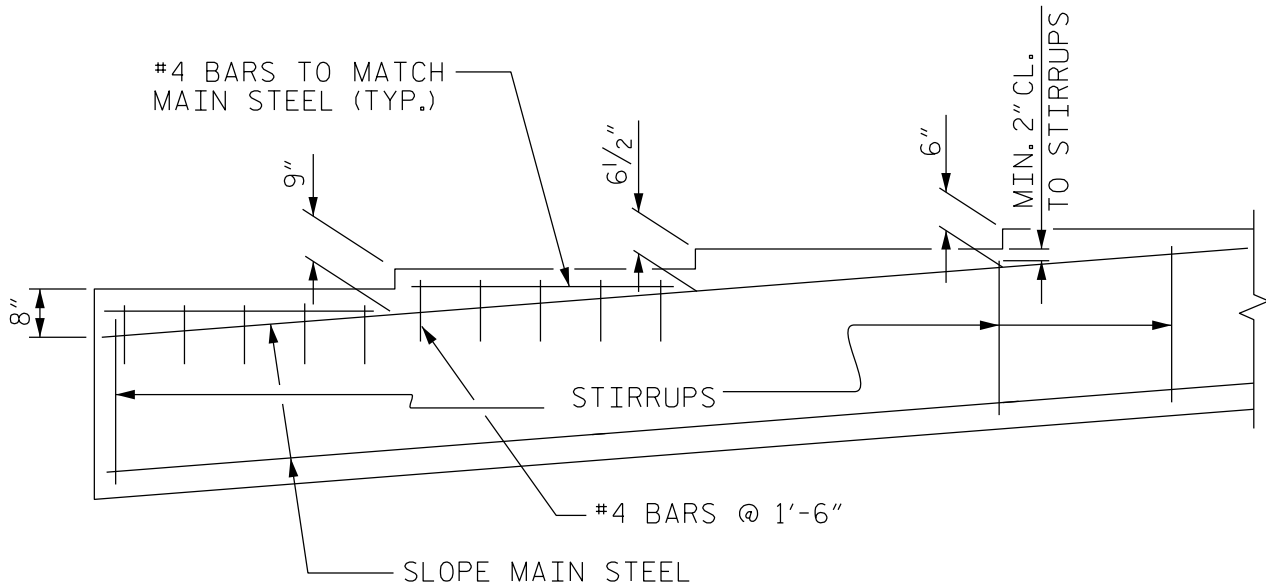

SLOPED CAP

REINFORCING STEEL IN TOP OF STEPPED BENT CAP

FIGURE 7 - 2

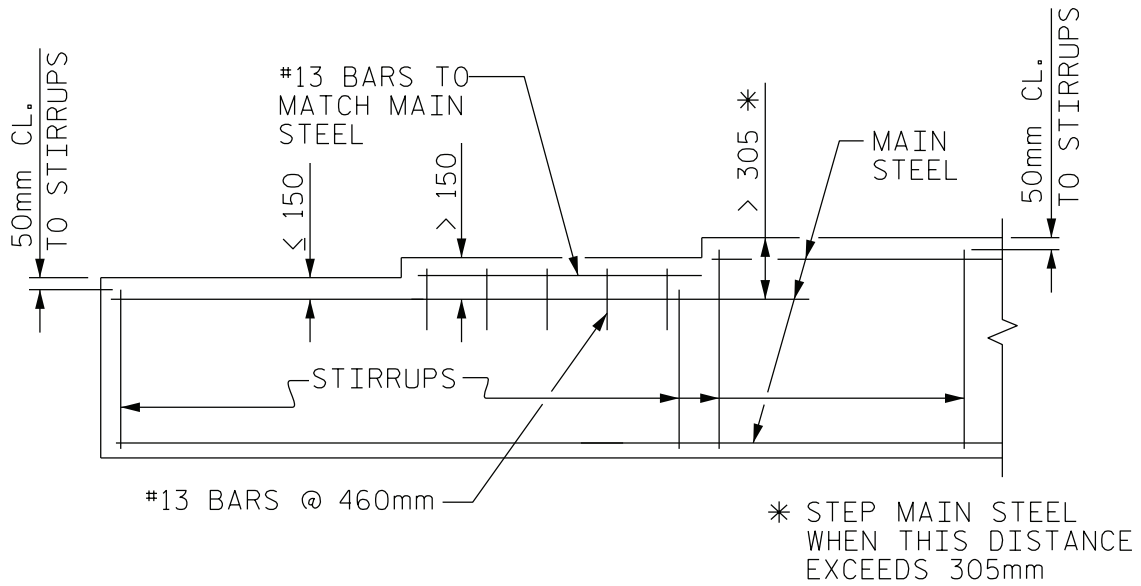

LEVEL CAP

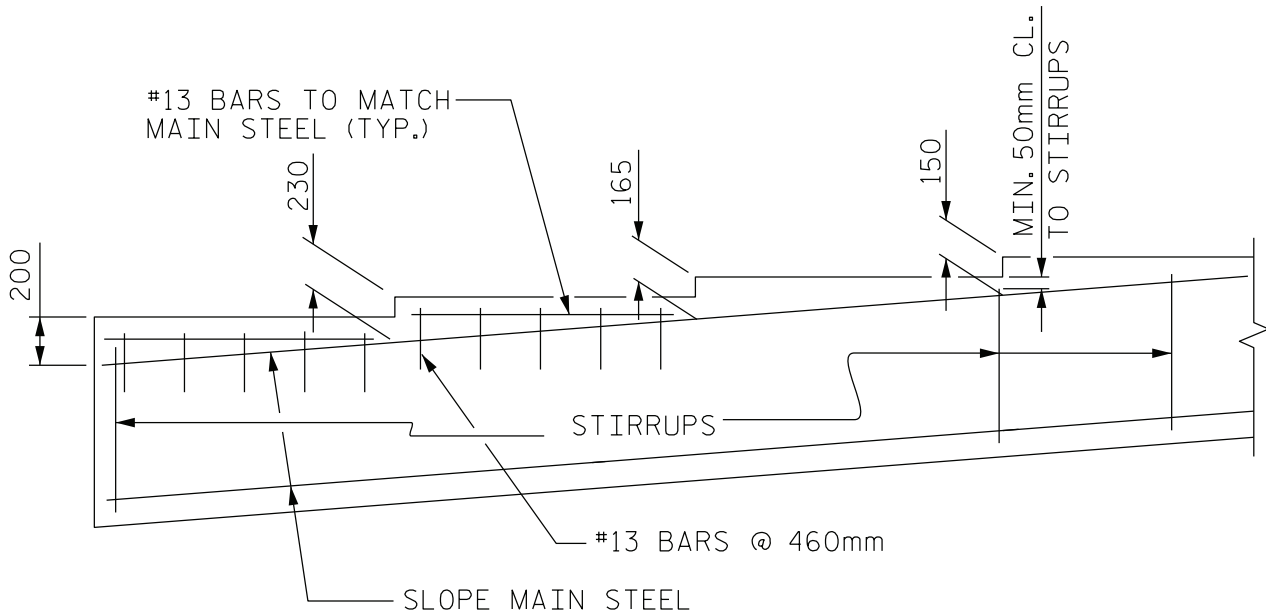

SLOPED CAP

REINFORCING STEEL IN TOP OF STEPPED BENT CAP

FIGURE 7 - 2 M