

SECTION THRU RAIL

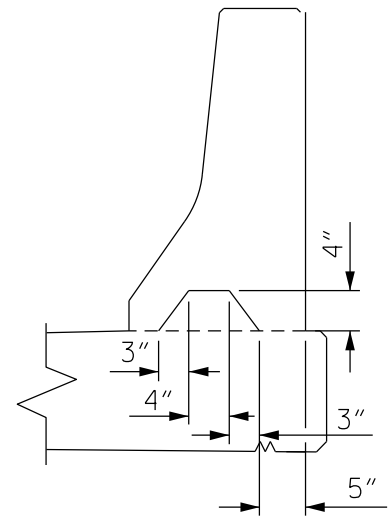

SECTION S-S  
 AT DAM IN OPEN JOINT  
 (THIS IS TO BE USED ONLY  
 WHEN SLIP FORM IS USED)

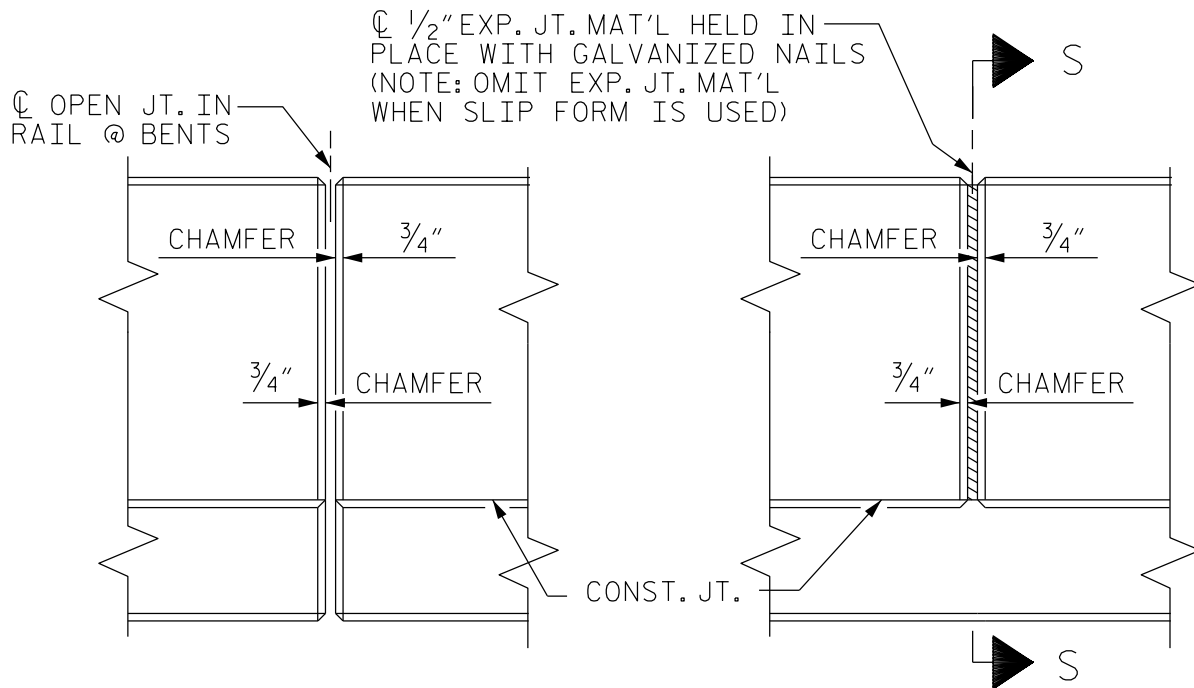

ELEVATION AT EXPANSION JOINTS

BARRIER RAIL DETAILS

**FIGURE 6 - 20**

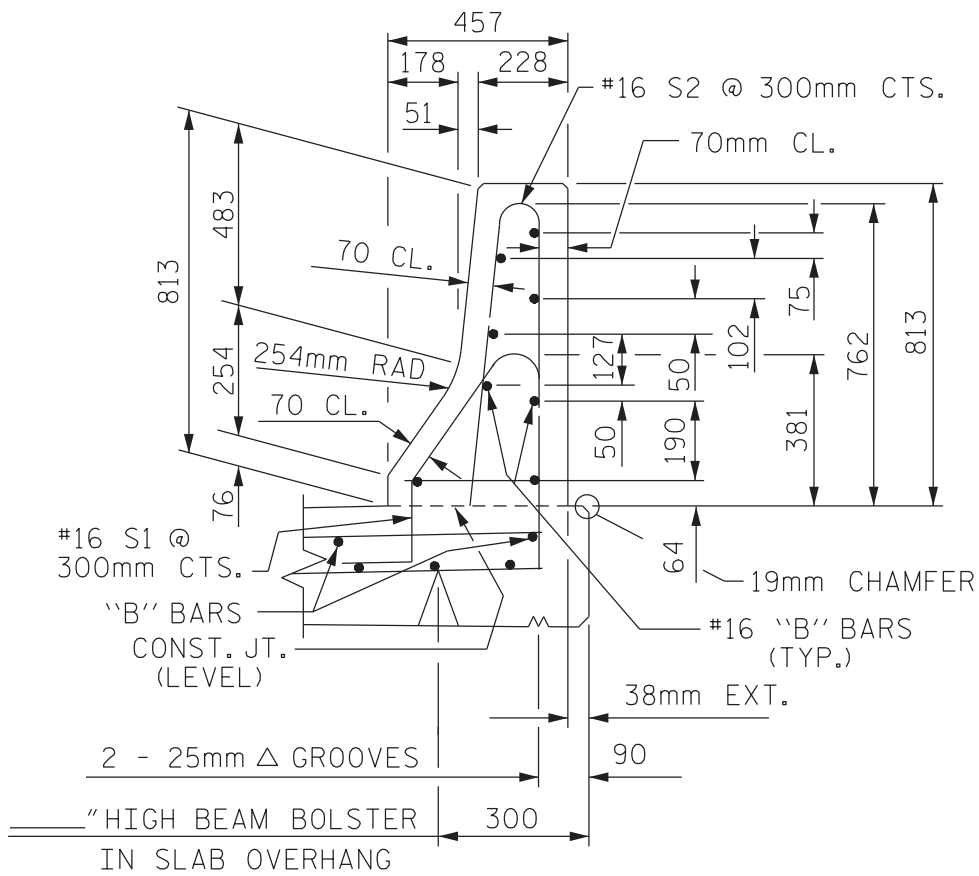

SECTION THRU RAIL

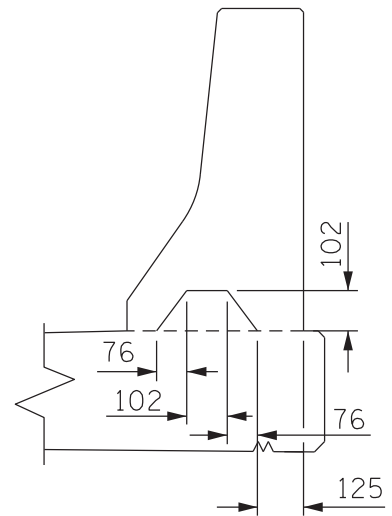

SECTION S-S  
 AT DAM IN OPEN JOINT  
 (THIS IS TO BE USED ONLY  
 WHEN SLIP FORM IS USED)

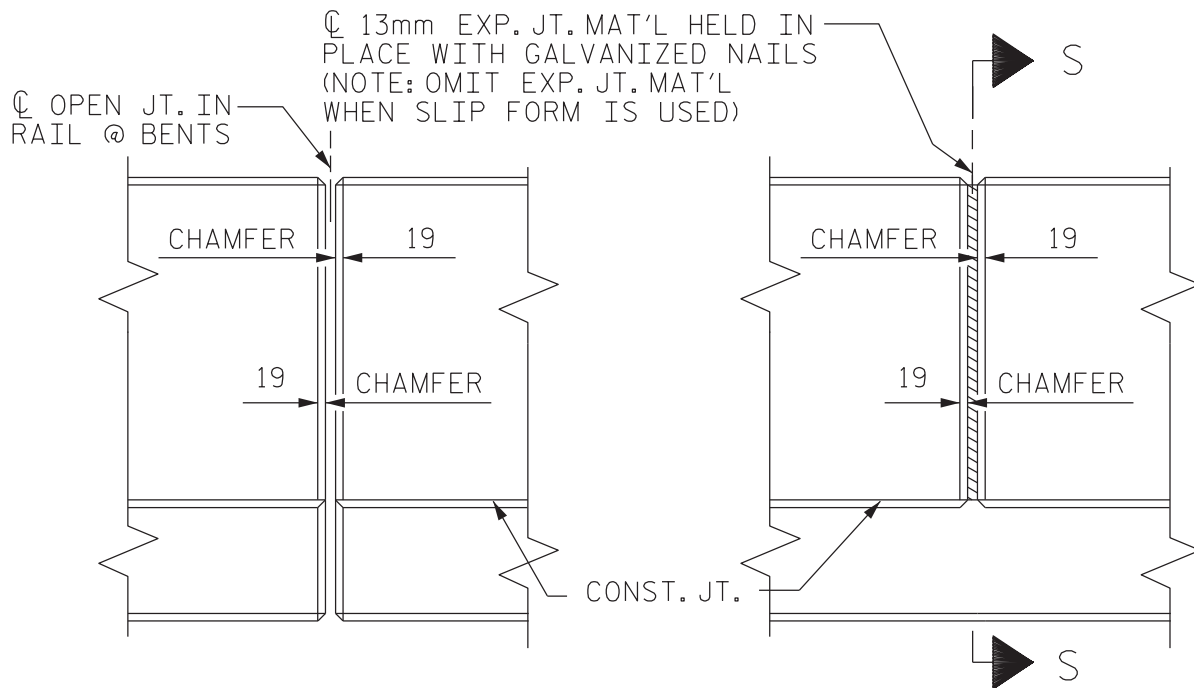

ELEVATION AT EXPANSION JOINTS

BARRIER RAIL DETAILS

**FIGURE 6 - 20 M**