

PLAN OF FOAM  
JOINT SEAL WITH COVER PLATE

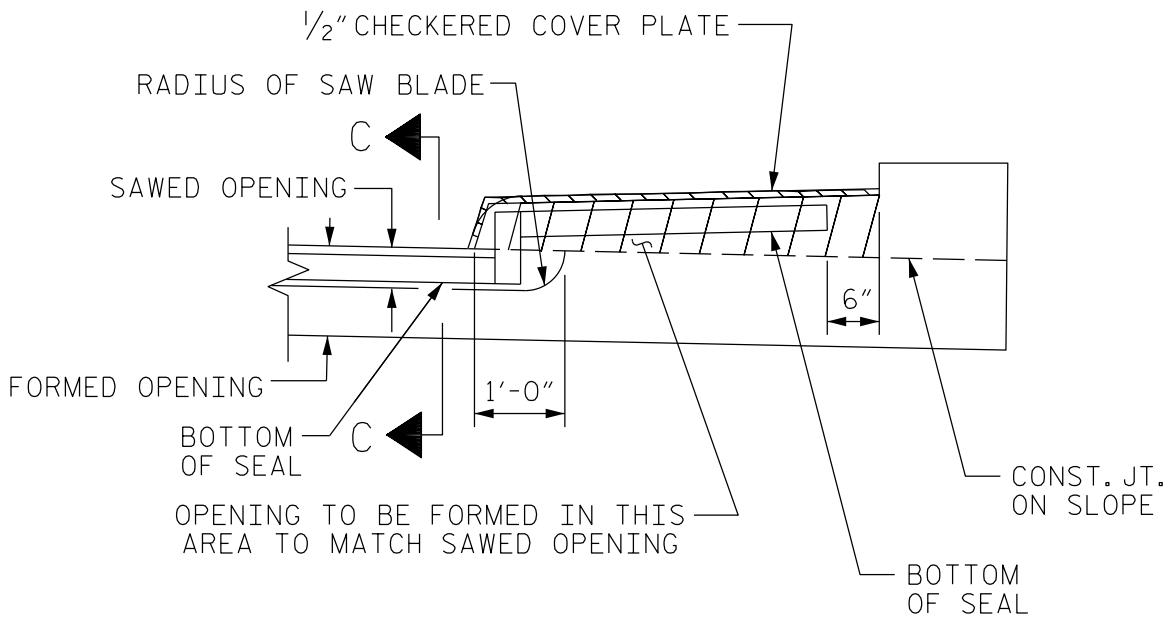

SECTION H-H

SIDEWALK WITH FOAM JOINT SEAL

FIGURE 6 - 46

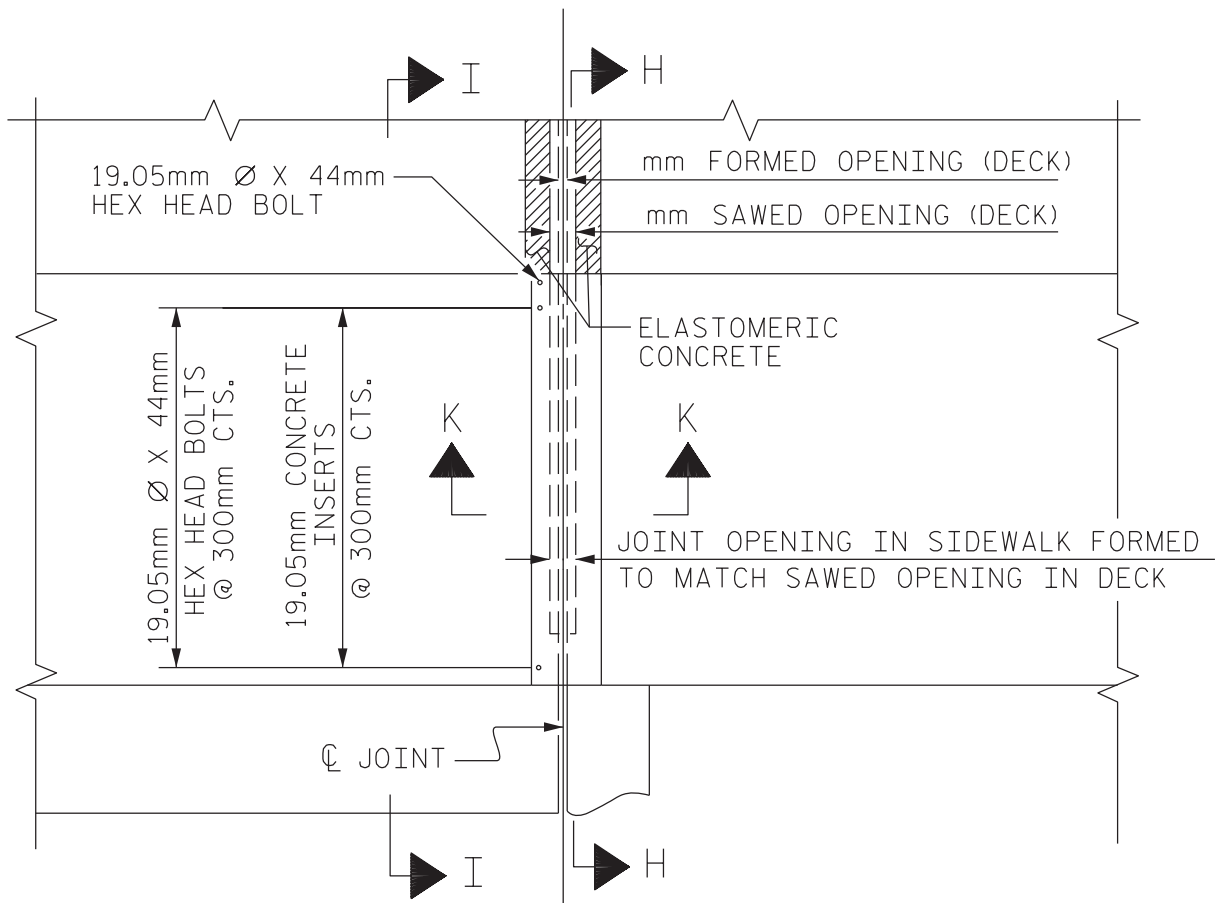

PLAN OF FOAM  
JOINT SEAL WITH COVER PLATE

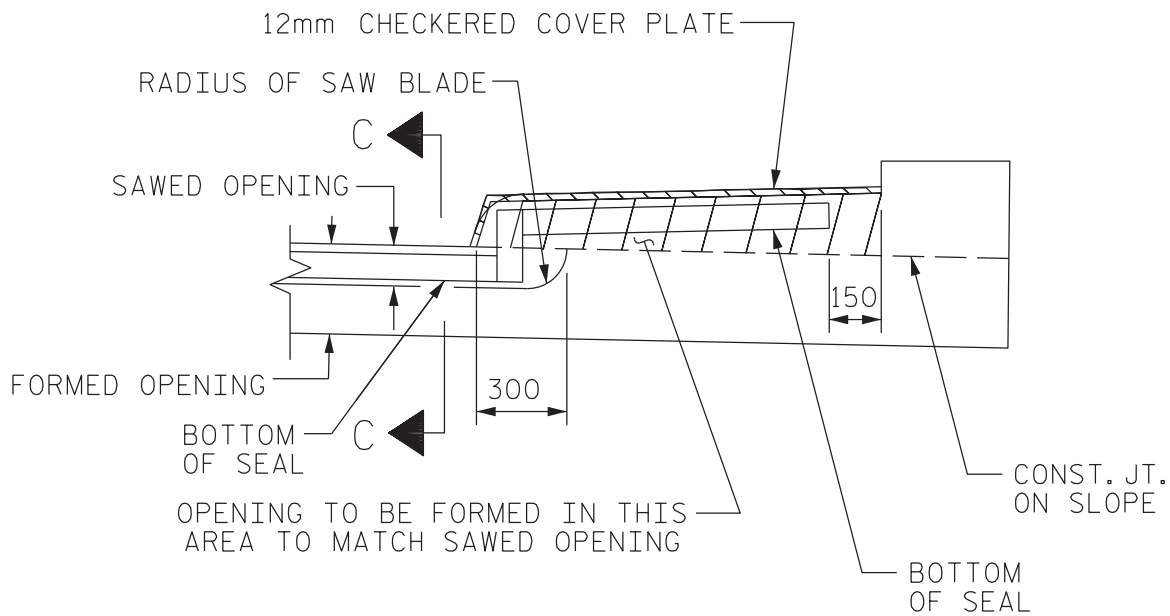

SECTION H-H

SIDEWALK WITH FOAM JOINT SEAL

**FIGURE 6 - 46 M**