

PART PLAN-EXTERIOR SECTION
NOTE: EXTERIOR SECTION SHOWN - INTERIOR SECTION SIMILAR EXCEPT OMIT S3 BARS.

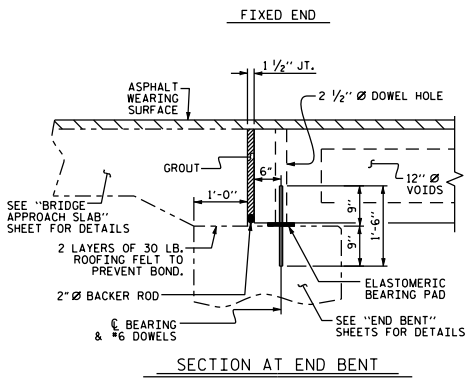

SECTION AT END BENT

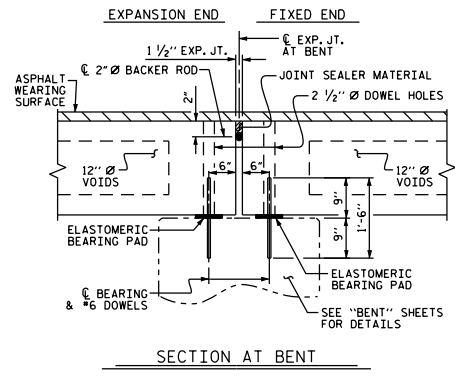

SECTION AT BENT

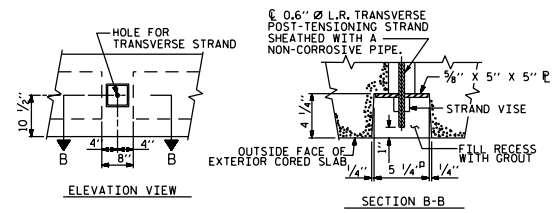

GRouted RECESS AT END OF POST-TENSIONED STRAND CORED SLABS

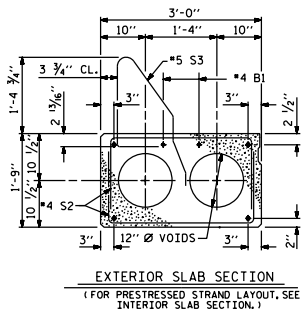

EXTERIOR SLAB SECTION
(FOR PRESTRESSED STRAND LAYOUT, SEE INTERIOR SLAB SECTION.)

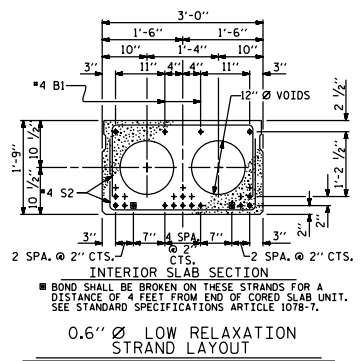

0.6" Ø LOW RELAXATION STRAND LAYOUT

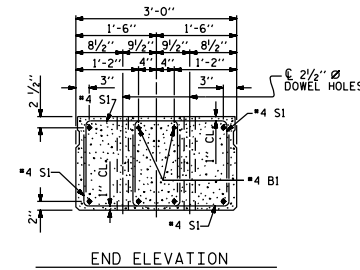

END ELEVATION
SHOWING PLACEMENT OF DOUBLE STIRRUPS AND LOCATION OF DOVEL HOLES (STRAND LAYOUT NOT SHOWN)
INTERIOR SLAB SECTION SHOWN - EXTERIOR SLAB SECTION SIMILAR EXCEPT SHEAR KEY LOCATION.

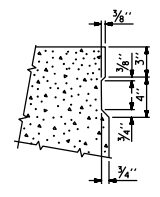

SHEAR KEY DETAIL
NOTE: OMIT SHEAR KEY ON OUTSIDE FACE OF EXTERIOR CORED SLABS.

PROJECT NO. EXAMPLE
COUNTY _____
STATION: _____
SHEET 1 OF 2

STATE OF NORTH CAROLINA
DEPARTMENT OF TRANSPORTATION
RALEIGH
STANDARD
3'-0" X 1'-9"
PRESTRESSED CONCRETE
CORED SLAB UNIT

ASSEMBLED BY :	DATE :
CHECKED BY :	DATE :
DRAWN BY : WJH 4/89	REV. 10/17/00 RWW/LES
CHECKED BY : FCJ 5/89	REV. 2/10/08 RWW/LES
	REV. 5/17/06 TLV/GM

REVISIONS						SHEET NO.
NO.	BY	DATE	NO.	BY	DATE	TOTAL SHEETS
1			3			
2			4			

FIGURE 6 - 82 M

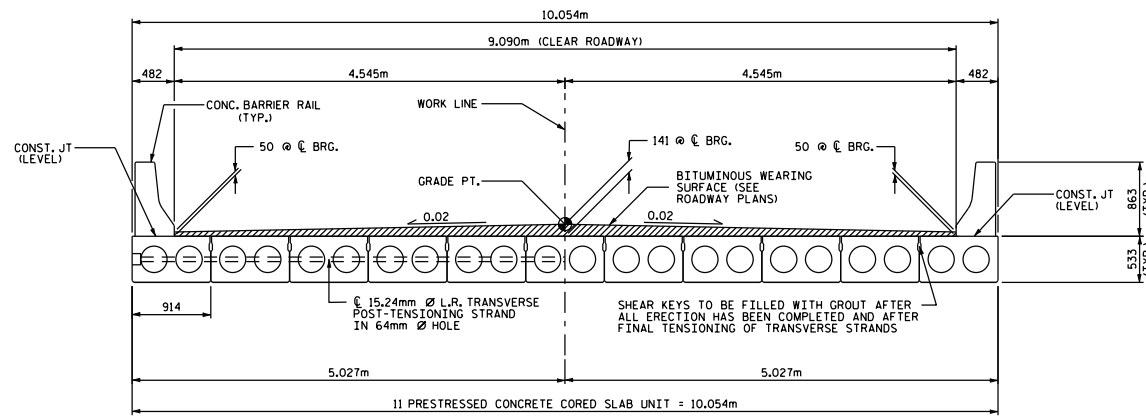

TYPICAL SECTION

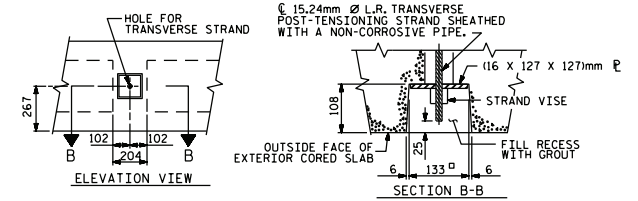

GRouted RECESS AT END OF POST-TENSIONED STRAND-CORED SLABS

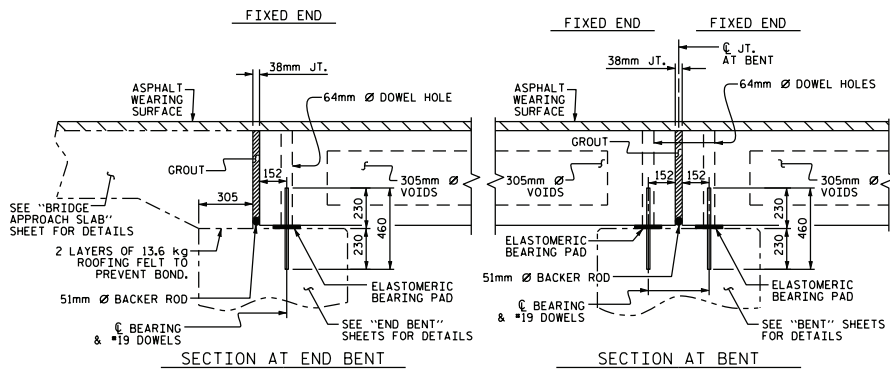

SECTION AT END BENT

SECTION AT BENT

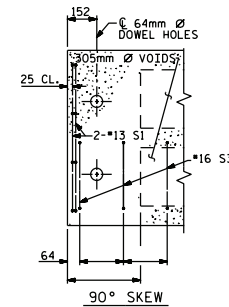

PART PLAN-EXTERIOR SECTION

NOTE: EXTERIOR SECTION SHOWN-INTERIOR SECTION SIMILAR EXCEPT OMIT S3 BARS.

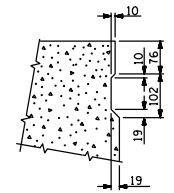

SHEAR KEY DETAIL

NOTE: OMIT SHEAR KEY ON OUTSIDE FACE OF EXTERIOR CORED SLABS.

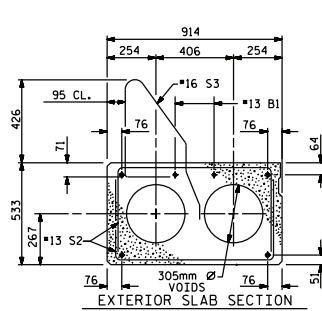

EXTERIOR SLAB SECTION

(FOR PRESTRESSED STRAND LAYOUT, SEE INTERIOR SLAB SECTION)

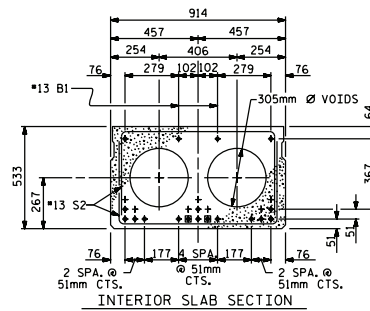

INTERIOR SLAB SECTION

■ BOND SHALL BE BROKEN ON THESE STRANDS FOR A DISTANCE OF 1.20 METERS FROM END OF CORED SLAB UNIT. SEE STANDARD SPECIFICATIONS ARTICLE 1078-7.

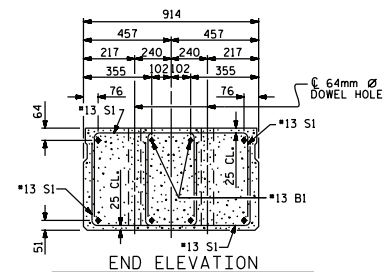

END ELEVATION

SHOWING PLACEMENT OF DOUBLE STIRRUPS AND LOCATION OF DOWEL HOLES (STRAND LAYOUT NOT SHOWN) INTERIOR SLAB SECTION SHOWN-EXTERIOR SLAB SECTION SIMILAR EXCEPT SHEAR KEY LOCATION.

ASSEMBLED BY :	DATE :
CHECKED BY :	DATE :
DRAWN BY : WJH 4/89	REV. 10/17/00 RWW/LES
CHECKED BY : FCJ 5/89	REV. 7/10/01R RWW/LES
	REV. 5/1/06 TLA/GM

PROJECT NO. _____
 COUNTY _____
 STATION: _____
 SHEET OF _____

STATE OF NORTH CAROLINA DEPARTMENT OF TRANSPORTATION RAILROAD					
STANDARD 914mm X 533 mm PRESTRESSED CONCRETE CORED SLAB UNIT					
REVISIONS					
NO.	BY:	DATE:	NO.	BY:	DATE:
1			3		
2			4		
					SHEET NO.
					TOTAL SHEETS