

NOTE TO DETAILER:

DO NOT CLIP PLATE AT TOP OUTSIDE CORNER OF CONNECTOR PLATE.

SEE FIGURE 6-113 FOR WELD TERMINATION DETAILS.

* = SHOW WELD SIZE.

** = CLIP SIZE = 2" MINIMUM BUT NOT LESS THAN 5 TIMES THE WEB THICKNESS + WELD SIZE.

CONNECTOR PLATE DETAILS

FIGURE 6 - 101

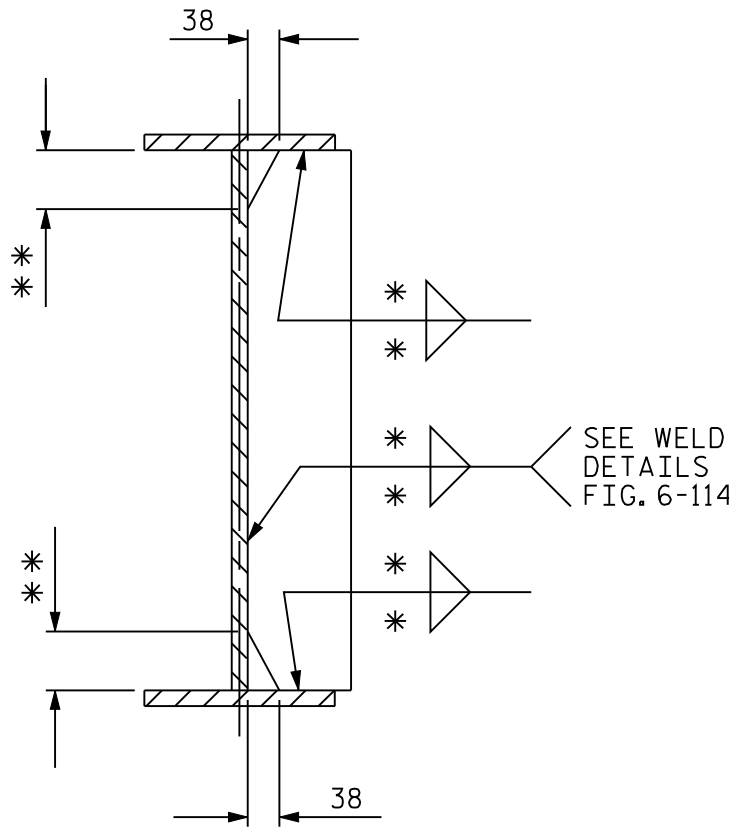

NOTE TO DETAILER:

DO NOT CLIP PLATE AT TOP OUTSIDE CORNER OF CONNECTOR PLATE.

SEE FIGURE 6-113 FOR WELD TERMINATION DETAILS.

* = SHOW WELD SIZE.

** = CLIP SIZE = 50mm MINIMUM BUT NOT LESS THAN 5 TIMES THE WEB THICKNESS + WELD SIZE.

CONNECTOR PLATE DETAILS

FIGURE 6 - 101 M