

END OF GIRDER DETAIL  
AT INTEGRAL END BENT

\* 1'-0" CTS. IS MAX. SPACING

BAR TYPES

MISSING BAR DIMENSIONS VARY  
WITH SKEW, CAP WIDTH, & GDR. TYPE

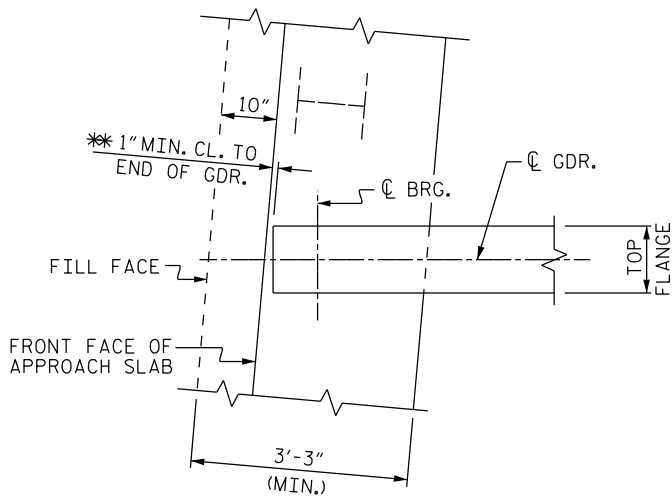

PLAN OF GIRDER AT INTEGRAL END BENT

\* DO NOT SHOW THIS DIMENSION ON PLANS

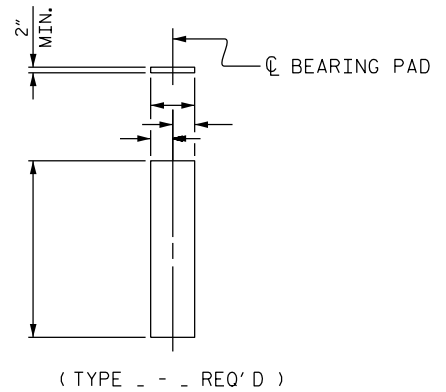

ELASTOMERIC BEARING DETAIL

INTEGRAL END BENT DETAILS

PCG SUPERSTRUCTURE

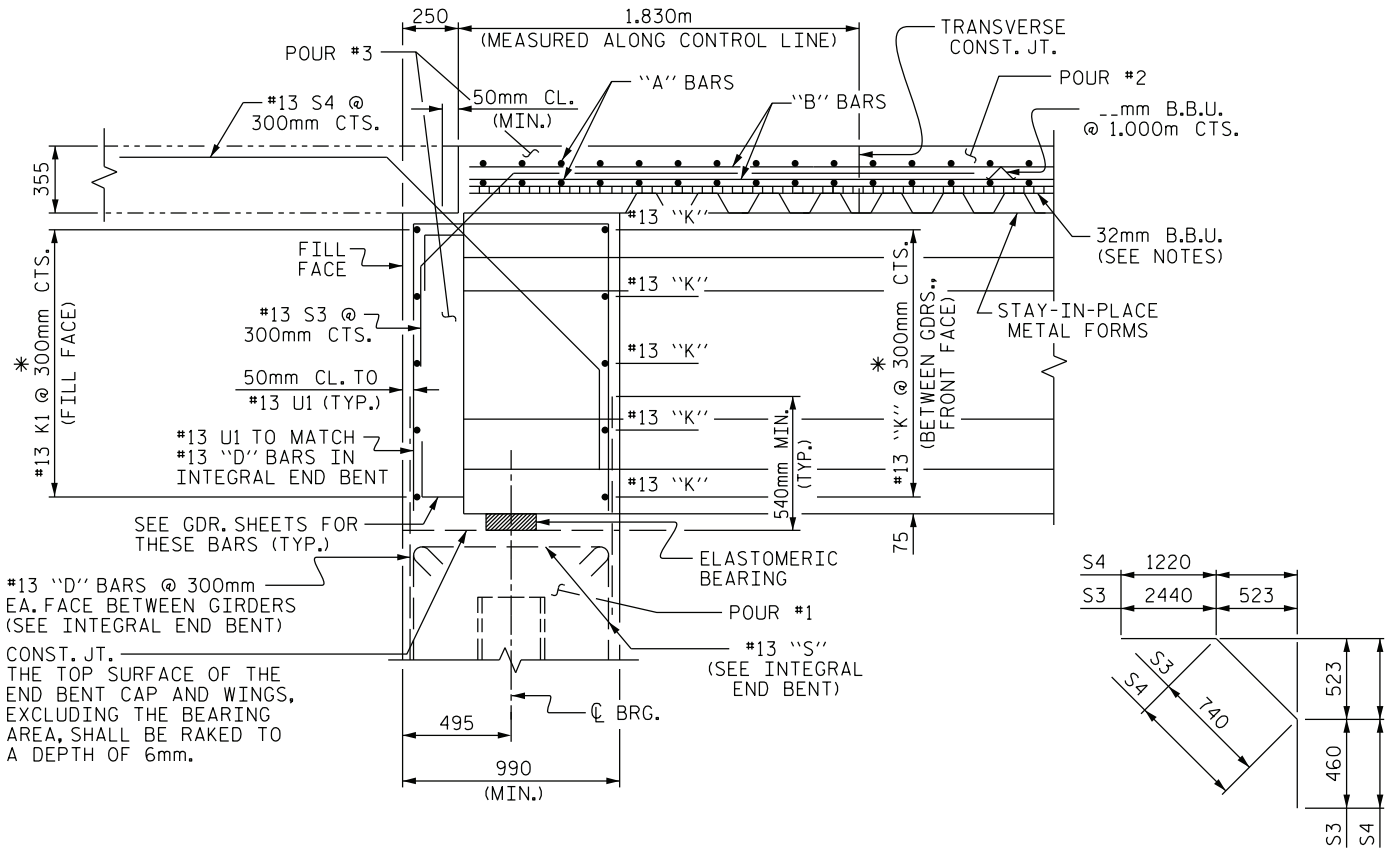

END OF GIRDER DETAIL AT INTEGRAL END BENT

\* 300mm CTS. IS MAX. SPACING

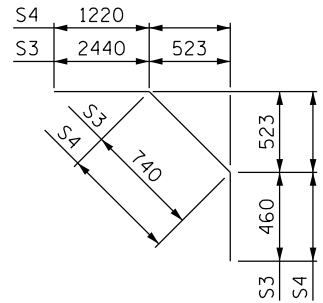

BAR TYPES

MISSING BAR DIMENSIONS VARY WITH SKEW, CAP WIDTH, & GDR. TYPE

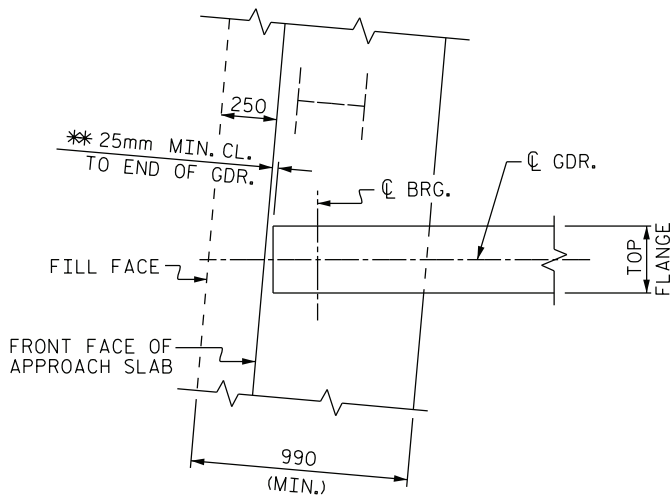

PLAN OF GIRDER AT INTEGRAL END BENT

\* DO NOT SHOW THIS DIMENSION ON PLANS

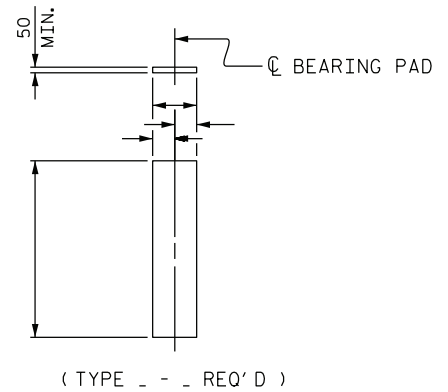

ELASTOMERIC BEARING DETAIL

INTEGRAL END BENT DETAILS

PCG SUPERSTRUCTURE

FIGURE 6 - 121 M