

PLAN W2

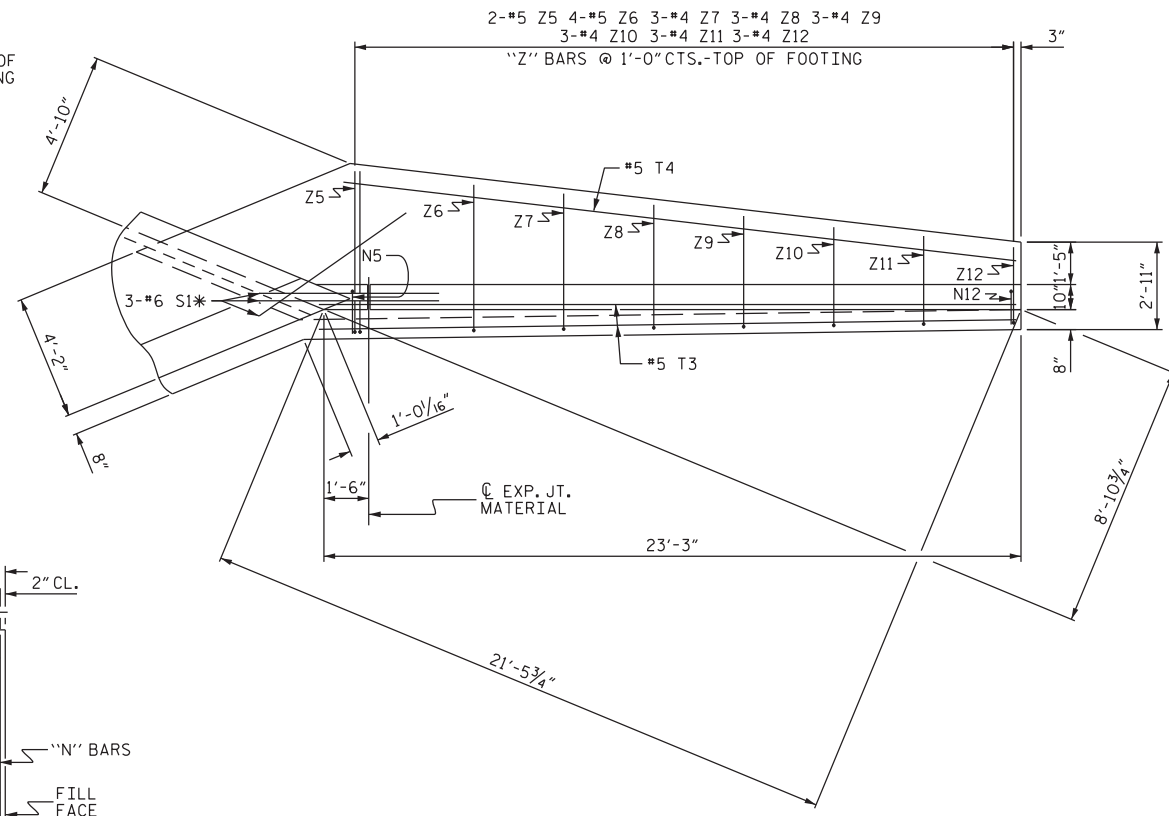

PLAN W1

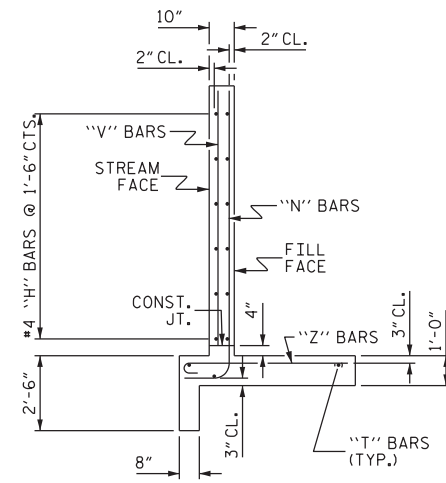

TYPICAL WING SECTION

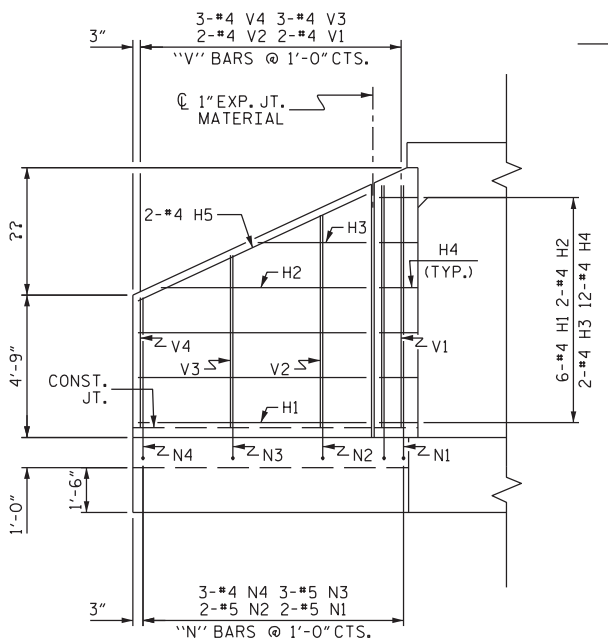

ELEVATION W2

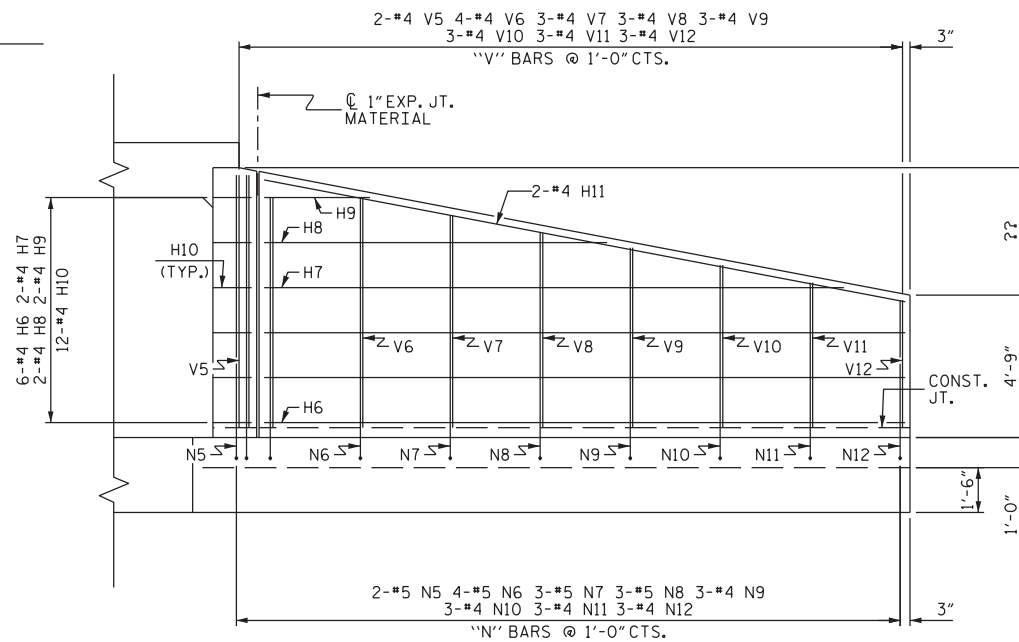

ELEVATION W1

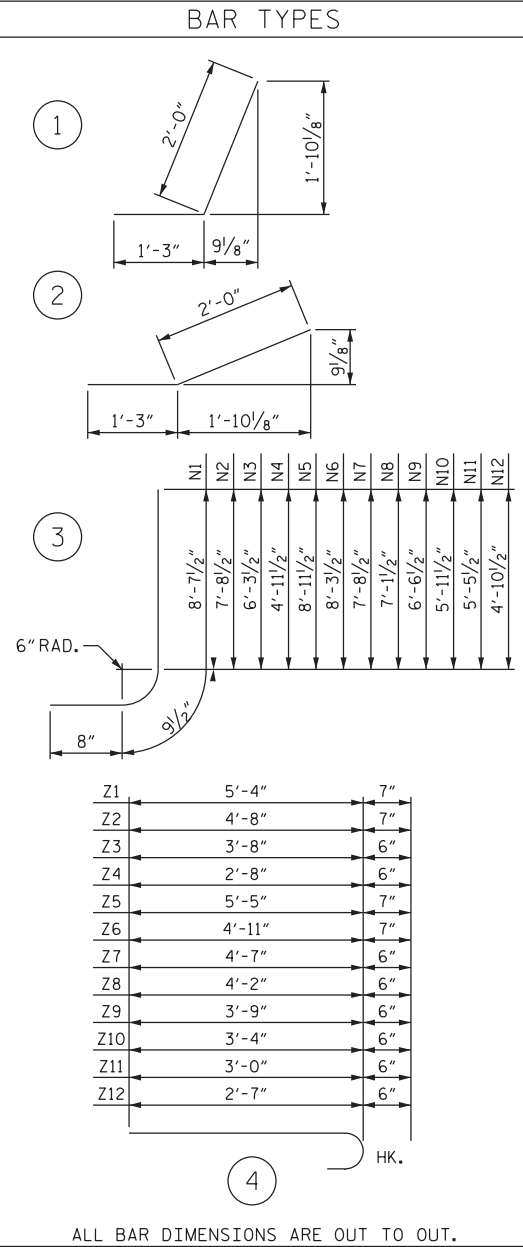

ALL BAR DIMENSIONS ARE OUT TO OUT.

BILL OF MATERIAL					
BAR NO.	NO.	SIZE	TYPE	LENGTH	WEIGHT
H1	12	#4	STR	7'-7"	61
H2	4	#4	STR	6'-10"	18
H3	4	#4	STR	3'-7"	10
H4	24	#4	1	3'-3"	52
H5	4	#4	STR	8'-5"	22
H6	12	#4	STR	21'-4"	171
H7	4	#4	STR	19'-4"	52
H8	4	#4	STR	11'-5"	31
H9	4	#4	STR	3'-6"	9
H10	24	#4	2	3'-3"	52
H11	4	#4	STR	21'-9"	58
N1	4	#5	3	10'-1"	42
N2	4	#5	3	9'-2"	38
N3	6	#5	3	7'-9"	48
N4	6	#4	3	6'-5"	26
N5	4	#5	3	10'-5"	43
N6	8	#5	3	9'-9"	81
N7	6	#5	3	9'-2"	57
N8	6	#5	3	8'-7"	54
N9	6	#4	3	8'-0"	32
N10	6	#4	3	7'-5"	30
N11	6	#4	3	6'-11"	28
N12	6	#4	3	6'-4"	25
S1	12	#6	STR	6'-0"	108
T1	4	#5	STR	9'-6"	40
T2	2	#5	STR	9'-3"	19
T3	4	#5	STR	23'-3"	97
T4	2	#5	STR	22'-7"	47
V1	4	#4	STR	8'-1"	22
V2	4	#4	STR	7'-1"	19
V3	6	#4	STR	5'-9"	23
V4	6	#4	STR	4'-4"	17
V5	4	#4	STR	8'-5"	22
V6	8	#4	STR	7'-8"	41
V7	6	#4	STR	7'-1"	28
V8	6	#4	STR	6'-6"	26
V9	6	#4	STR	6'-0"	24
V10	6	#4	STR	5'-5"	22
V11	6	#4	STR	4'-10"	19
V12	6	#4	STR	4'-3"	17
Z1	4	#5	4	5'-11"	25
Z2	4	#5	4	5'-3"	22
Z3	6	#4	4	4'-2"	17
Z4	6	#4	4	3'-2"	13
Z5	4	#5	4	6'-0"	25
Z6	8	#5	4	5'-6"	46
Z7	6	#4	4	5'-1"	20
Z8	6	#4	4	4'-8"	19
Z9	6	#4	4	4'-3"	17
Z10	6	#4	4	3'-10"	15
Z11	6	#4	4	3'-6"	14
Z12	6	#4	4	3'-1"	12
REINFORCING STEEL					1876 LBS
FOR 4 WINGS					
CLASS A CONCRETE					
4 WINGS					29.1 CY
2 HEADWALLS					CY
2 END CURTAIN WALLS					CY
TOTAL					CY

PROJECT NO. _____
 _____ COUNTY
 STATION: _____
 SHEET _ OF _

STATE OF NORTH CAROLINA
 DEPARTMENT OF TRANSPORTATION
 RALEIGH
 STANDARD WINGS
 FOR SINGLE BARREL
 CONCRETE BOX CULVERT
 H = 8'-0" SLOPE = 2:1
 45° SKEW

ASSEMBLED BY :	-	DATE :	-
CHECKED BY :	-	DATE :	-
DRAWN BY :	CCJ 01/00	REV. 6/19	MAA/THC
CHECKED BY :	RWW 03/00		

REVISIONS						SHEET NO.
NO.	BY:	DATE:	NO.	BY:	DATE:	TOTAL SHEETS
1			3			
2			4			

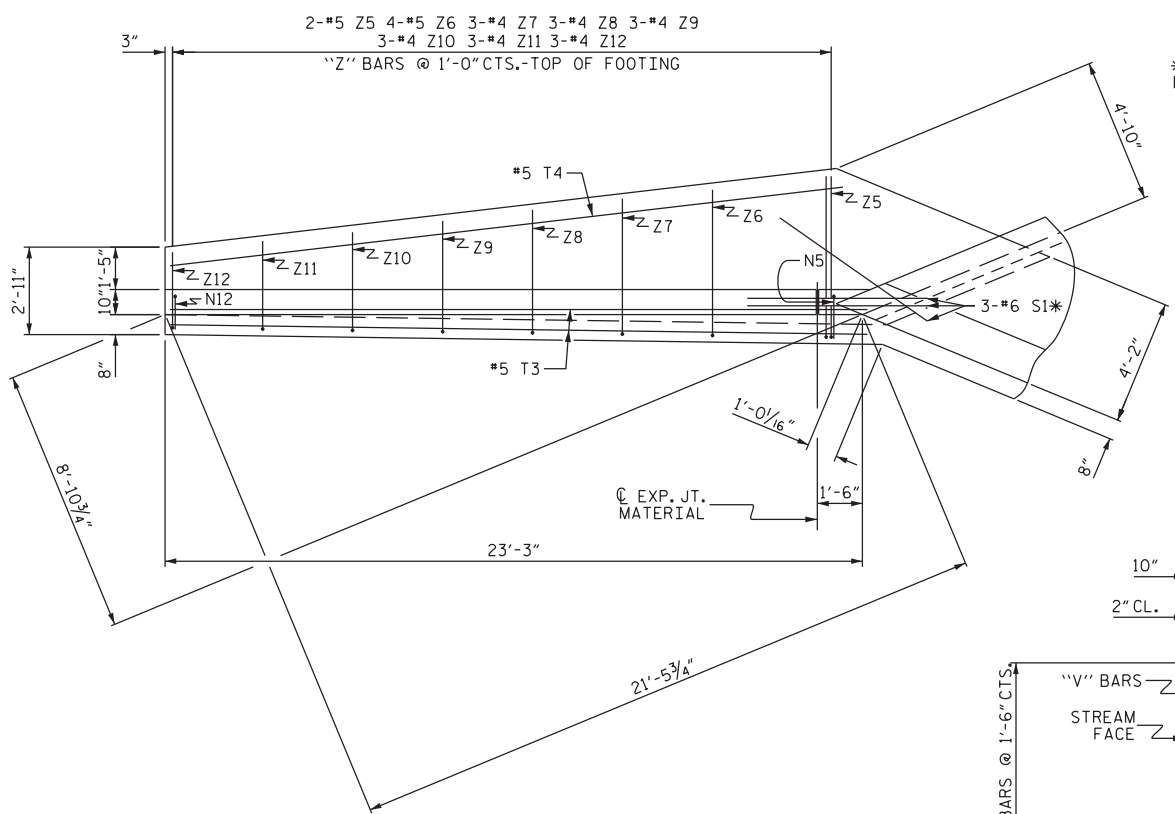

PLAN W1

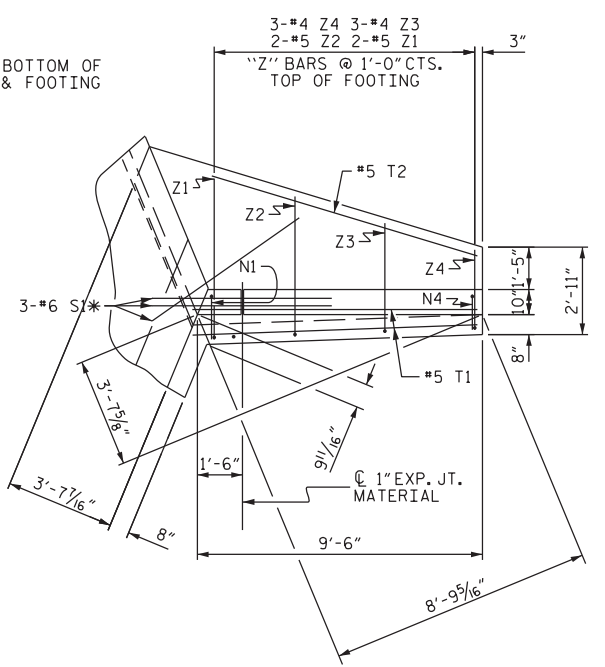

PLAN W2

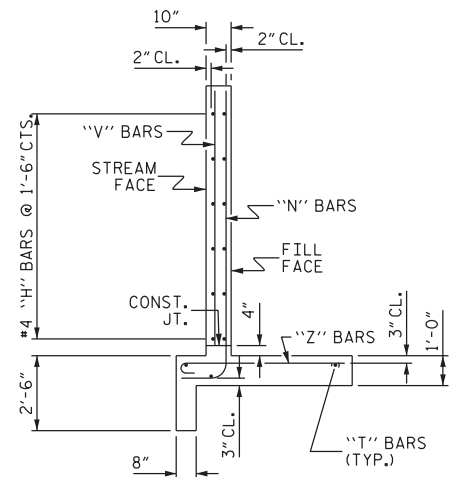

TYPICAL WING SECTION

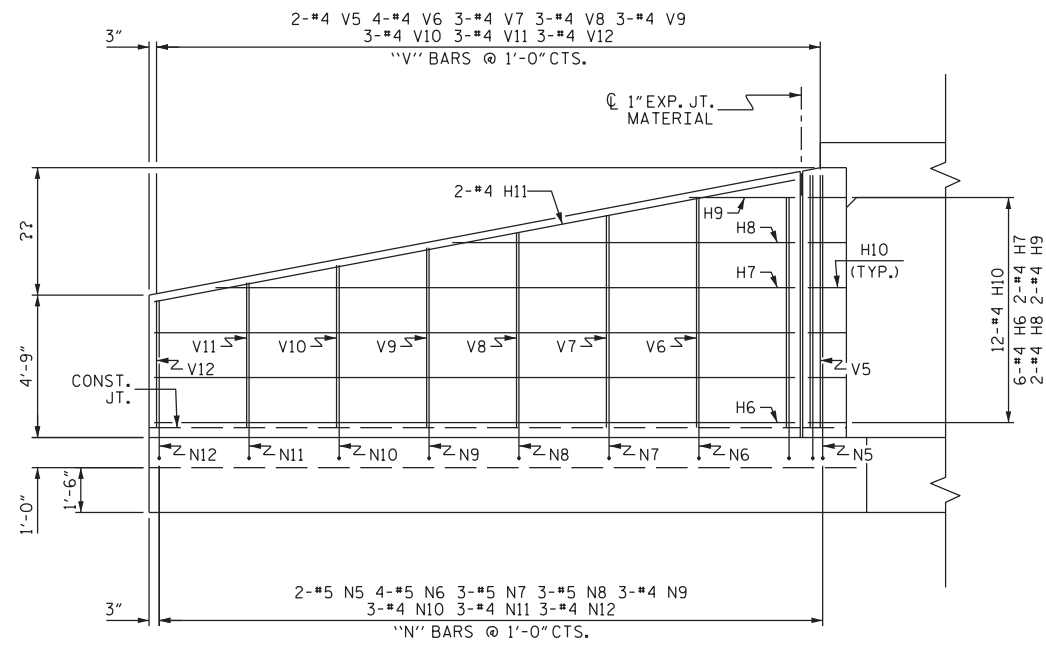

ELEVATION W1

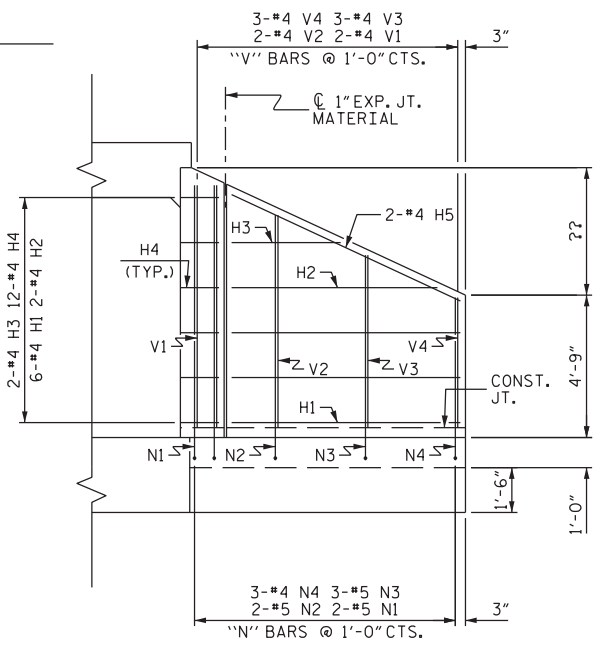

ELEVATION W2

BAR TYPES				BILL OF MATERIAL					
NO.	SIZE	TYPE	LENGTH	BAR NO.	SIZE	TYPE	LENGTH	WEIGHT	
1	2'-0"		1'-10 1/8"	H1	12	#4 STR	7'-7"	61	
2	2'-0"		9 1/8"	H2	4	#4 STR	6'-10"	18	
3	8'-7 1/2"		7"-8 1/2"	H3	4	#4 STR	3'-7"	10	
4	7'-8 1/2"		6'-3 1/2"	H4	24	#4	3'-3"	52	
5	6'-3 1/2"		4'-11 1/2"	H5	4	#4 STR	8'-5"	22	
6	4'-11 1/2"		8'-3 1/2"	H6	12	#4 STR	21'-4"	171	
7	8'-3 1/2"		7'-8 1/2"	H7	4	#4 STR	19'-4"	52	
8	7'-8 1/2"		7'-1 1/2"	H8	4	#4 STR	11'-5"	31	
9	7'-1 1/2"		5'-11 1/2"	H9	4	#4 STR	3'-6"	9	
10	5'-11 1/2"		5'-5 1/2"	H10	24	#4	3'-3"	52	
11	5'-5 1/2"		4'-10 1/2"	H11	4	#4 STR	21'-9"	58	
12	4'-10 1/2"			N1	4	#5	3	10'-1"	42
				N2	4	#5	3	9'-2"	38
				N3	6	#5	3	7'-9"	48
				N4	6	#4	3	6'-5"	26
				N5	4	#5	3	10'-5"	43
				N6	8	#5	3	9'-9"	81
				N7	6	#5	3	9'-2"	57
				N8	6	#5	3	8'-7"	54
				N9	6	#4	3	8'-0"	32
				N10	6	#4	3	7'-5"	30
				N11	6	#4	3	6'-11"	28
				N12	6	#4	3	6'-4"	25
				S1	12	#6 STR	6'-0"	108	
				T1	4	#5 STR	9'-6"	40	
				T2	2	#5 STR	9'-3"	19	
				T3	4	#5 STR	23'-3"	97	
				T4	2	#5 STR	22'-7"	47	
				V1	4	#4 STR	8'-1"	22	
				V2	4	#4 STR	7'-1"	19	
				V3	6	#4 STR	5'-9"	23	
				V4	6	#4 STR	4'-4"	17	
				V5	4	#4 STR	8'-5"	22	
				V6	8	#4 STR	7'-8"	41	
				V7	6	#4 STR	7'-1"	28	
				V8	6	#4 STR	6'-6"	26	
				V9	6	#4 STR	6'-0"	24	
				V10	6	#4 STR	5'-5"	22	
				V11	6	#4 STR	4'-10"	19	
				V12	6	#4 STR	4'-3"	17	
				Z1	4	#5	4	5'-11"	25
				Z2	4	#5	4	5'-3"	22
				Z3	6	#4	4	4'-2"	17
				Z4	6	#4	4	3'-2"	13
				Z5	4	#5	4	6'-0"	25
				Z6	8	#5	4	5'-6"	46
				Z7	6	#4	4	5'-1"	20
				Z8	6	#4	4	4'-8"	19
				Z9	6	#4	4	4'-3"	17
				Z10	6	#4	4	3'-10"	15
				Z11	6	#4	4	3'-6"	14
				Z12	6	#4	4	3'-1"	12

ALL BAR DIMENSIONS ARE OUT TO OUT.

PROJECT NO. _____ COUNTY _____
 STATION: _____
 SHEET ____ OF ____
 STATE OF NORTH CAROLINA
 DEPARTMENT OF TRANSPORTATION
 RALEIGH
**STANDARD WINGS
 FOR SINGLE BARREL
 CONCRETE BOX CULVERT**
 H = 8'-0" SLOPE = 2:1
 135° SKEW

ASSEMBLED BY : -	DATE : -
CHECKED BY : -	DATE : -
DRAWN BY : CCJ 01/00	REV. 6/19 MAA/THC
CHECKED BY : RWW 03/00	

DOCUMENT NOT CONSIDERED FINAL UNLESS ALL SIGNATURES COMPLETED	REVISIONS						SHEET NO. TOTAL SHEETS
	NO.	BY:	DATE:	NO.	BY:	DATE:	
	1			3			
	2			4			