



April **2026**



**Structures Management Unit
OpenBridge Designer Manual**

CONTENTS

Chapter 1 1-1

1.1 NCDOT Structures Management OpenBridge Manual 1-1

1.2 NCDOT Migration Plan 1-1

1.2.1 Structures Management Unit Migration Plan 1-2

1.3 v8 File Conversions and Expectations 1-2

1.3.1 DGN Migration Expectations 1-2

 Modifying Converted v8 Drawings 1-2

 Adding Drawings to a Plan Set 1-3

 Standard Drawings and Standard Plans 1-3

1.3.2 DGN Plan Conversion 1-3

1.3.3 GEOPAK File Incorporation 1-3

 1.3.3.1 Set Feature Definition Tool 1-5

1.3.4 Adding the Terrain 1-6

1.4 Workspace 1-9

1.4.1 Consultants 1-9

1.4.2 SMU Workspace 1-9

1.4.3 2D Element Templates 1-9

1.4.4 Level Name Convention 1-10

1.4.5 Feature Definitions 1-11

1.4.6 SMU Tools 1-12

 1.4.6.1 Placing Typical Section From NCBDS 1-12

 1.4.6.2 Placing LRFR Summary Table From NCBDS 1-13

 1.4.6.3 Placing Bolted Field Splice From NCBDS 1-14

1.4.7 Bridge Templates 1-15

1.5 Acronyms And Abbreviations 1-20

1.6 Definitions 1-21

CHAPTER 1

GENERAL

1.1 NCDOT STRUCTURES MANAGEMENT OPENBRIDGE MANUAL

This manual is intended to be a guidance manual, providing Engineers and Technicians guidance in current Structures Management Unit (SMU) practice using OpenBridge software. To preserve the autonomy of Engineers and Technicians and encourage the application of new ideas and advancements in the technology, this manual does not attempt to address all possible scenarios that may arise in the use of OpenBridge software in the design and of modeling highway structures. It is assumed that many of these guidelines contained within will necessarily continue to evolve as the software continues to evolve.

The users of this manual are encouraged to present ideas that may vary from those contained herein. These suggestions will be considered and implemented as deemed appropriate.

This manual does not attempt to reproduce information that is adequately addressed in the Bentley training documents and/or their other publications.

Users should also reference the NCDOT CADD Manual.

1.2 NCDOT MIGRATION PLAN

In July of 2021, North Carolina Department of Transportation (NCDOT) started the process of migrating its computer-aided design and drafting (CADD) software from Bentley MicroStation V8i and Geopak to Bentley OpenX. OpenX is a comprehensive multi-discipline three-dimensional (3D) modeling application that can be used in the delivery of projects from concept through construction.

To transition to ORD, NCDOT developed a Migration Plan with milestone activities and associated targets for each Unit within NCDOT to utilize OpenX in the production of designs and plans for new projects. In July of 2021, SMU converted projects that were less than 75% complete in v8 to OpenX. In January of 2022, SMU transitioned all projects to OpenBridge. In August of 2023, the Director of Technical Services issued a memorandum requiring all new projects begin in OpenX (https://connect.ncdot.gov/projects/Project-Management/Documents/08-02-2023%20NCDOT_OpenX_Migration.pdf)

1.2.1 Structures Management Unit Migration Plan

Under NCDOT's Migration Plan, each Unit has unique activities and associated targets as part of their migration plan. SMU has a three-phase migration plan for transitioning to the use of Bentley OpenBridge Designer (OBD), the transportation structural component of ORD.

SMU's three-phase migration plan is as follows:

- **Phase 1** – Transition Staff and Consultants to the use of OBD for 2D plan production.
- **Phase 2** – Transition Staff and Consultants to producing 3D models to be used in reference with other Unit's models and to create 2D plans.
- **Phase 3** – Transition Staff and Consultants to producing 3D models for complete digital delivery.

1.3 V8 FILE CONVERSIONS AND EXPECTATIONS

For projects with files still in MicroStation format, these files will need to be converted to OpenBridge format. This section is intended to provide guidance and expectations for those project files.

1.3.1 DGN Migration Expectations

V8 files can be opened in the OpenBridge software without loss of data. When a V8 file is opened in OpenBridge, a message will appear asking if the user would like to update the file. Accept the update to convert the drawing to the OpenBridge format. When a drawing is converted, the V8 levels, attributes, and format will be brought forward in the updated file, however these attributes will not be converted to match the Structure Management Unit's (SMU) OpenBridge workspace. Once updated to OpenBridge, there is no need to change the text and line styles to the new OpenBridge format or move to the use of sheet models. Note, because the V8 attributes have not been updated to the OpenBridge workspace, text fonts will appear different from the text displayed in the OpenBridge drawings. If no modifications to the drawing content are required, the drawing may be printed (on paper or PDF) as usual.

Modifying Converted v8 Drawings

When V8 drawings are converted to OpenBridge and a note or dimension needs to be added, copy and paste existing text then edit the new note or dimension. If a drawing detail needs modification, the user should proceed as usual. Note if new lines are placed in the drawing, their naming convention will utilize the OpenBridge workspace and will appear the same as the existing lines when printed.

Adding Drawings to a Plan Set

When additional drawings are needed for an existing plan set, use OpenBridge to develop the new drawings and save them as separate files using SMU's file naming convention. These drawings will utilize the OpenBridge workspace and the text will appear different from the converted or modified drawings. During the OpenBridge transition period, SMU plan sets with differing text fonts will be acceptable.

Standard Drawings and Standard Plans

SMU's Standard Drawings and Plans have been converted to the OpenBridge format using the procedures described above. The Standards will not be updated for consistency with the OpenBridge workspace until revisions to the content are required. During plan development, always use standard drawings and plans available on SMU website.

1.3.2 DGN Plan Conversion

V8 files can be opened in the OpenBridge software without loss of data. When a V8 file is opened in OpenBridge, the following message will appear:

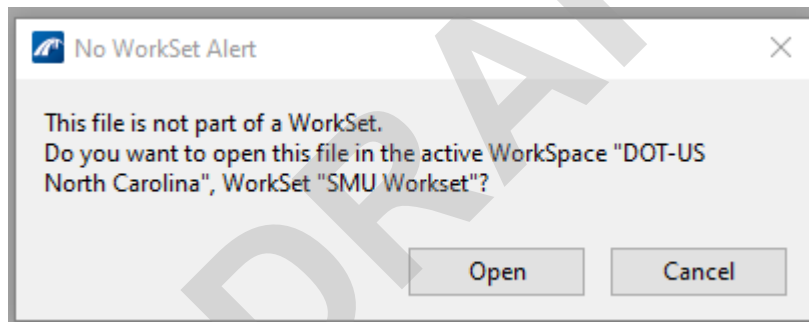

Click "Open" and the file will be migrated to the current SMU workspace. The file will now be in the SMU OpenBridge workspace with the old v8 line styles, text styles, borders, and features.

1.3.3 GEOPAK File Incorporation

Projects that originated in V8i and Geopak can be incorporated into OpenBridge Designer files by importing the geometry (.gdk files) and terrain (.tin files).

To incorporate an alignment from projects that used older versions of MicroStation and Geopak, take the following steps:

1st Locate the gpk file from the previous project and make a copy. Save the copy in your OBD project folder.

2nd Create an OBD “Model” file in your project folder.

3rd In the “Model” file, click on the “Import” icon and drop down to “Geometry”.

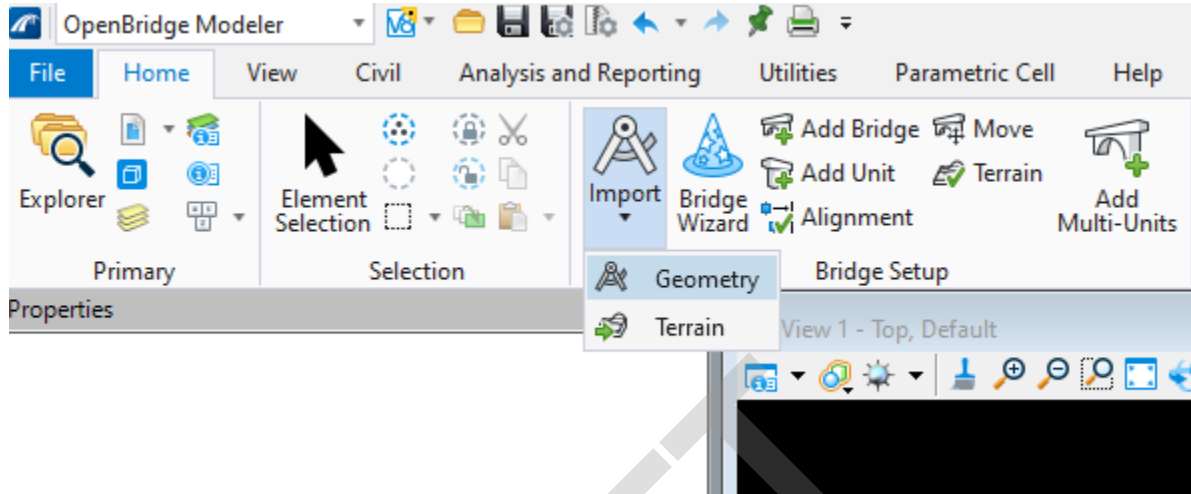

4th Locate the saved copy of the gpk file from step 1.

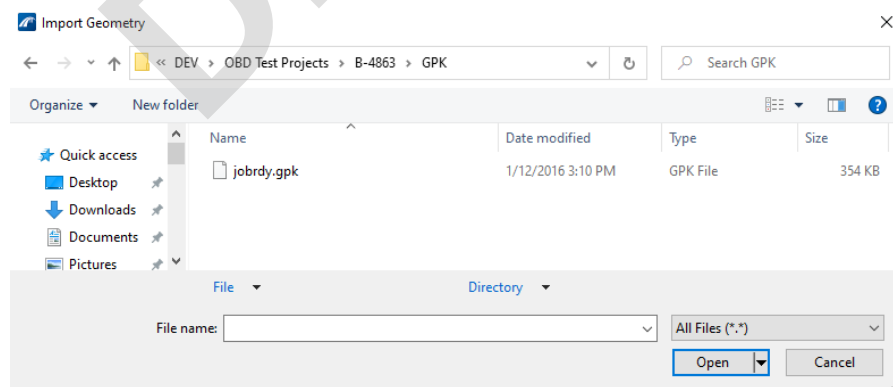

5th Select the alignment and feature definitions for the alignment. Select each alignment and its profile one at a time and assign the correct features for each one. This will require repeating this step for each alignment needed for your project.

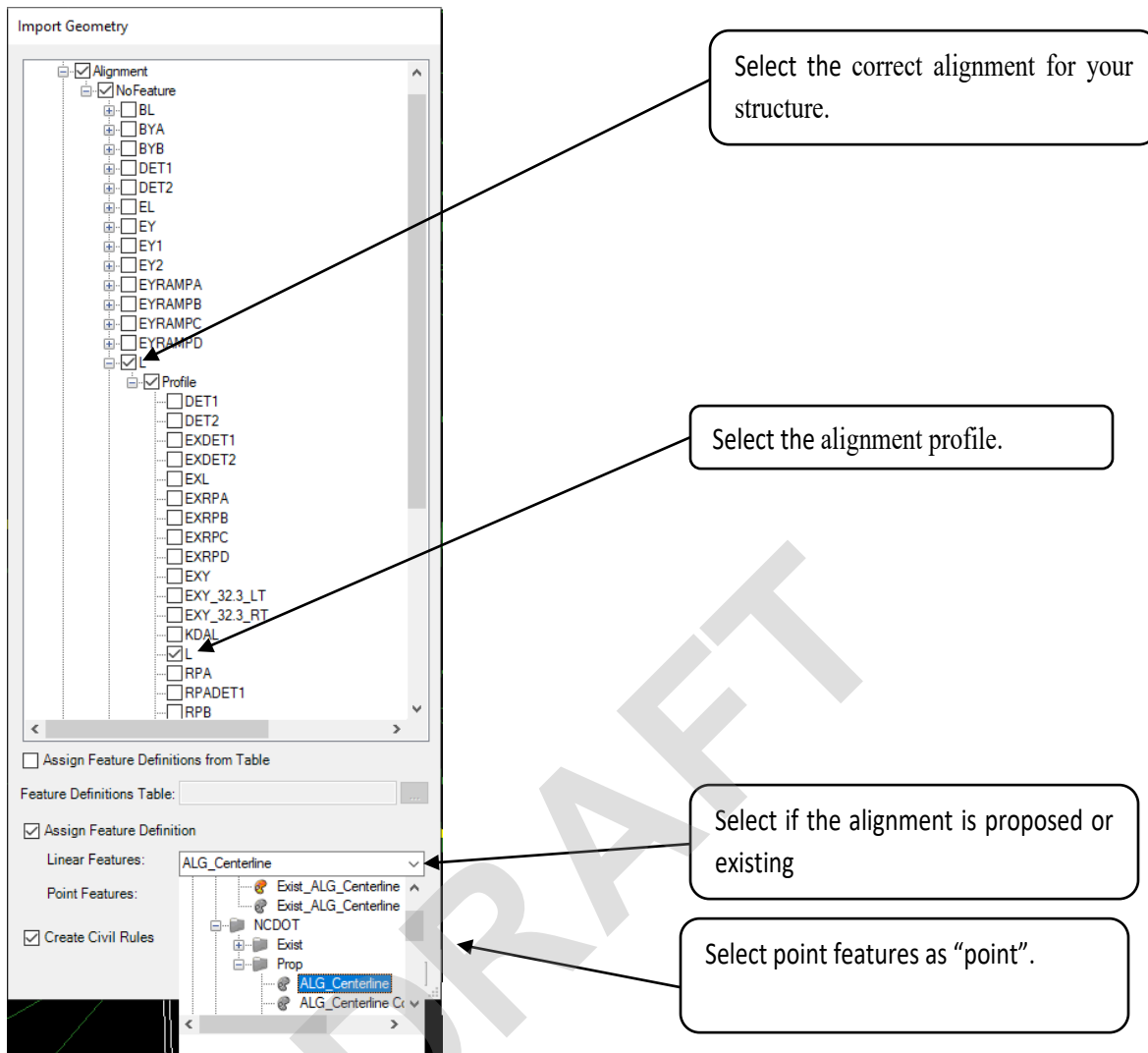

1.3.3.1 Set Feature Definition Tool

If you didn't check the "Assign Feature Definition" box, take the following steps:

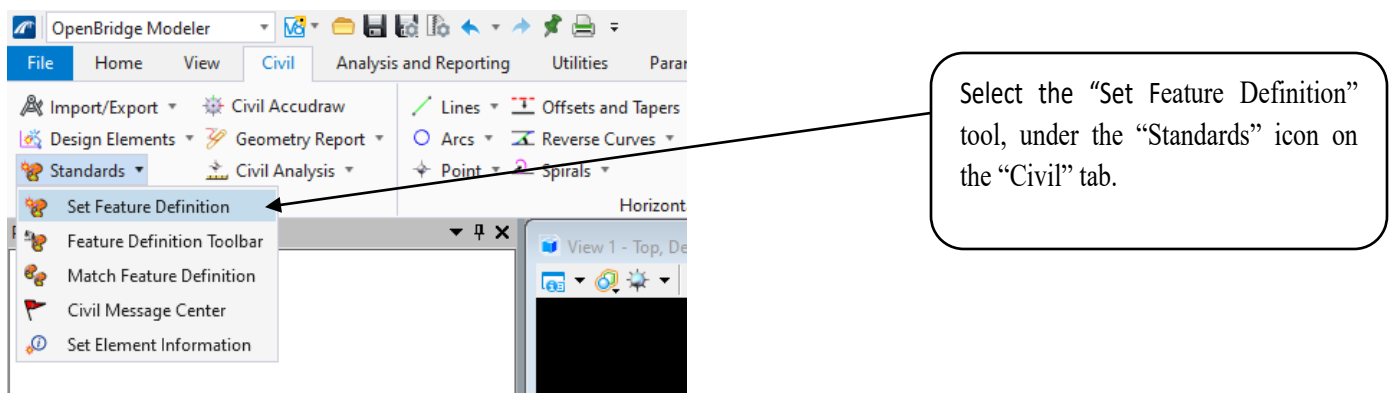

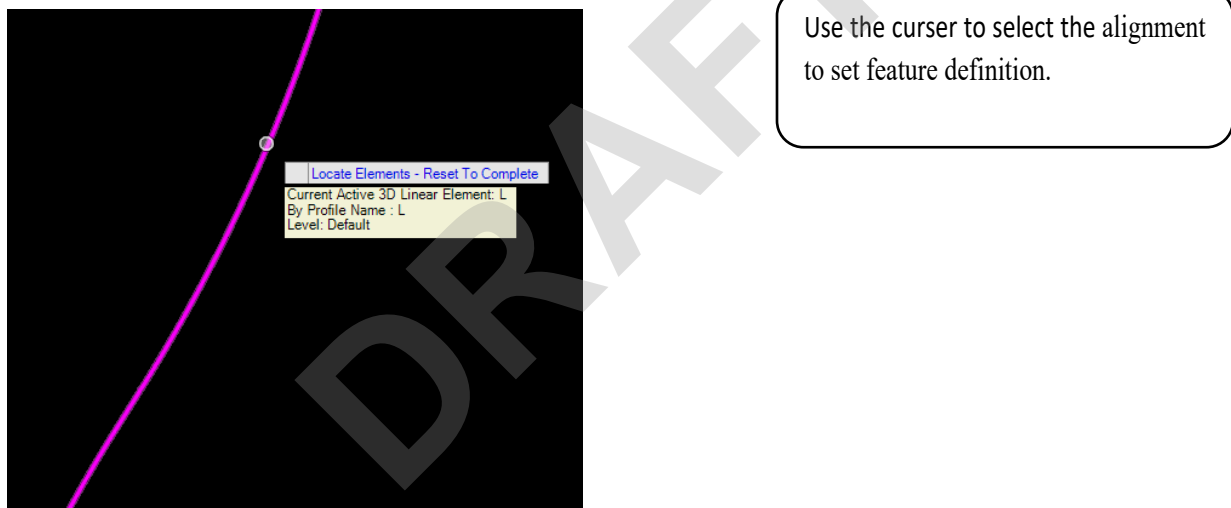

1.3.4 Adding the Terrain

To incorporate a terrain from projects that used older versions of MicroStation and Geopak, take the following steps:

- 1st Locate the .tin file from the previous project and make a copy. Save the copy in your OBD project folder.
- 2nd Click on the “Import” icon and drop down to “Terrain”.

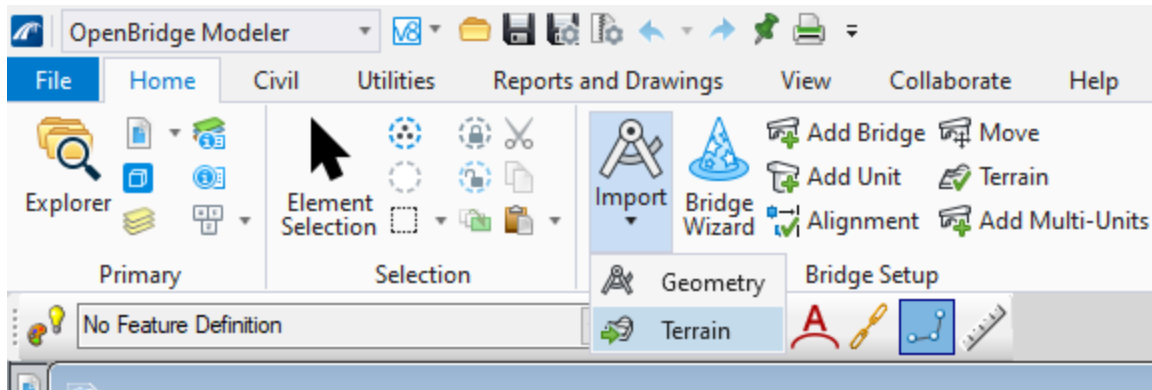

3rd Locate the saved .tin file from Step 1.

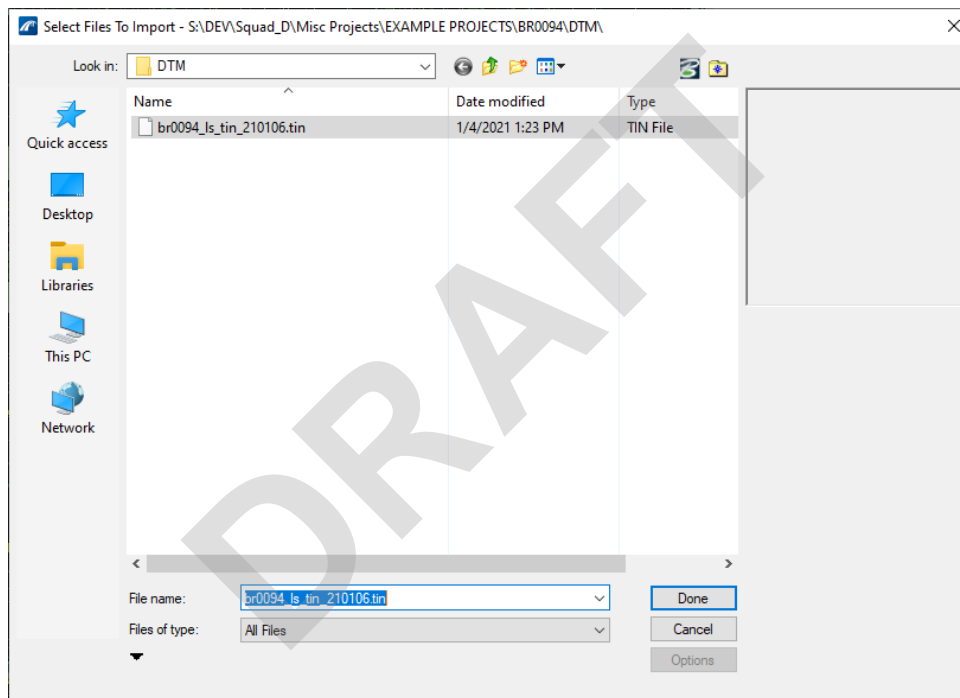

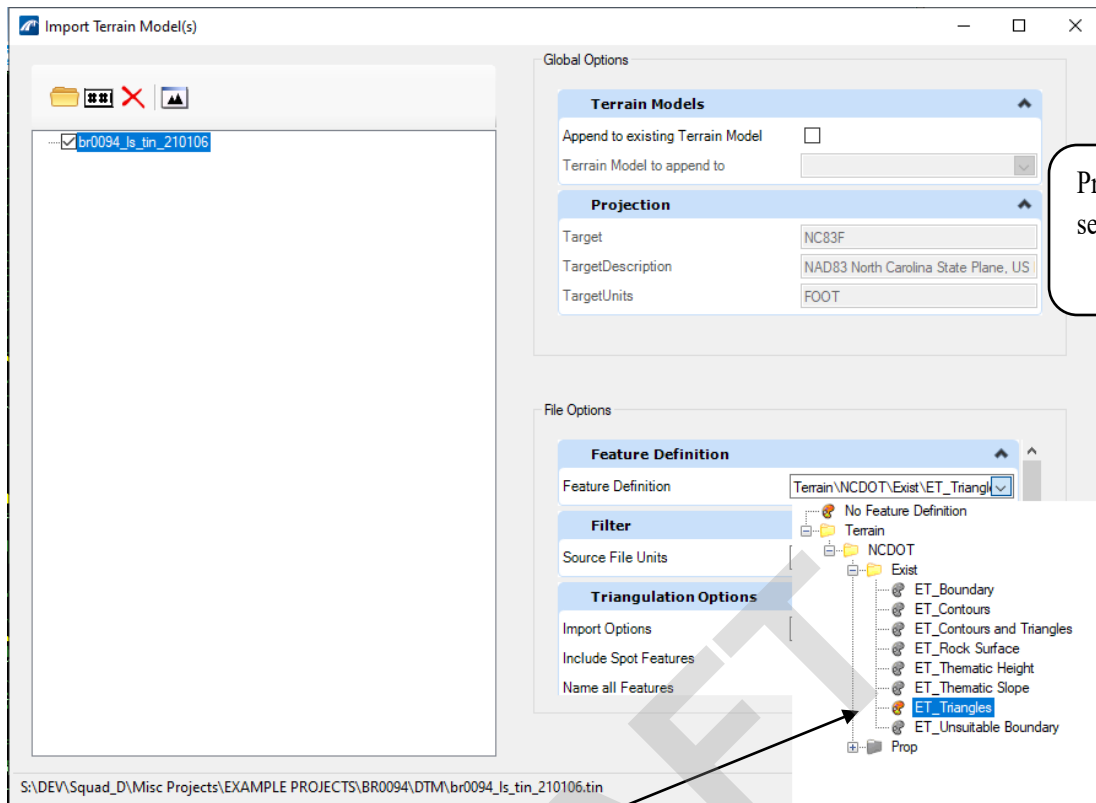

Select "ET_Triangles"

Projection Targets should be set from the seed file.

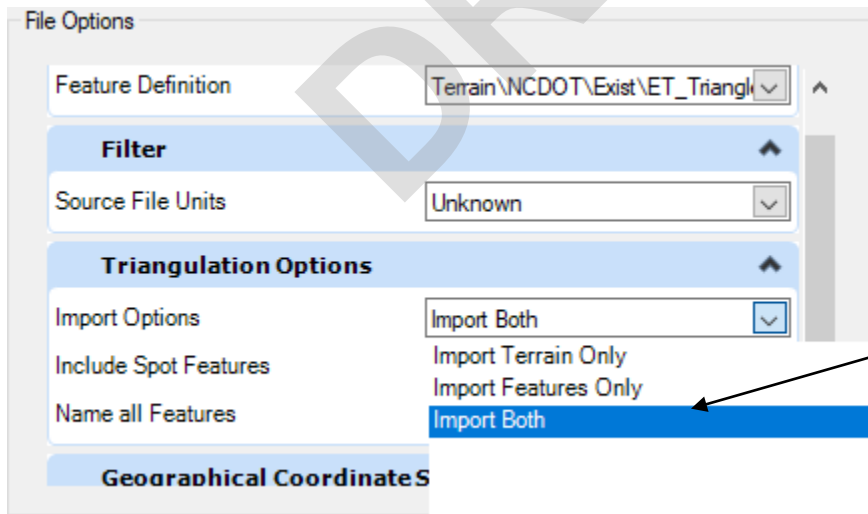

Leave File Units as "Unknown"

Select "Import Both"

4th Click on "Import"

1.4 WORKSPACE

Bentley OpenX is NCDOT's only authorized CADD software platform. OpenBridge Designer (OBD) is the structural operating system of Bentley's OpenX Design products. OBD is compatible with OpenX allowing for structures to be built on top of referenced OpenX files and includes Bentley's LEAP design software package.

1.4.1 Consultants

As part of NCDOT's transition to project file storage on ProjectWise, Structures Management's OBD workspace is incorporated into a managed workspace in ProjectWise.

Consultants can find ProjectWise guidance documents for creating, saving, searching and exporting documents can be found here:

<https://connect.ncdot.gov/resources/CADD/Pages/ProjectWise.aspx>.

Consultants can find the latest software version of OpenBridge being used by the Department here:

<https://connect.ncdot.gov/resources/CADD/CADD Documents/NCDOT CADD Software Versions.pdf>

1.4.2 SMU Workspace

Similar to previous versions of MicroStation, in an effort to maintain consistency amongst contract plans and now 3D models Structures Management will continue to produce and maintain a custom workspace for OBD in the NCDOT Unified WorkSpace.

OpenBridge uses element templates, level names, feature symbology and feature definitions. The current workspace has new workspace properties and will continue to evolve with 3D templates and libraries.

1.4.3 2D Element Templates

Line styles are now assigned to Element Templates, which must be selected before use. Using the correct Drawing Line Styles is important in OBD to capture accurate quantities.

1st Use the Drawing workflow

2nd Select the Template dropdown tab

3rd Select the correct Element to be drawn, ei. If you're drawing an End Bent cap, select "Abutments"... "Caps"

Once the correct Element Template is selected, the Line Style/Level is automatically set

Once the correct Element Template is selected, you can use the Placement tools for drawing

Note: Do not place dimensions and text in the Design Model.

1.4.5 Feature Definitions

SMU OBD workspace has feature definitions defined for many of the commonly used proposed bridge elements.

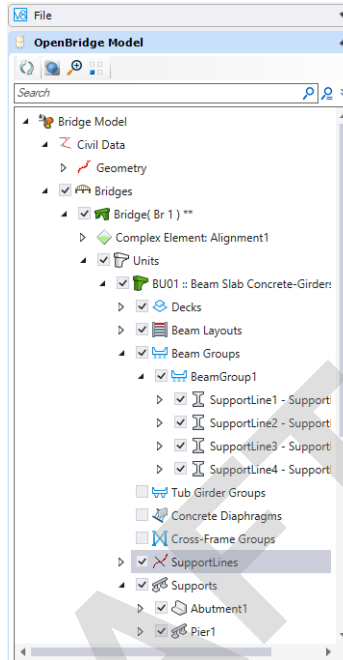

1.4.6 SMU Tools

The SMU OBD workspace has a “SMU” tab under the Drawing workflow, where the in-house SMU NCBDS tools are located.

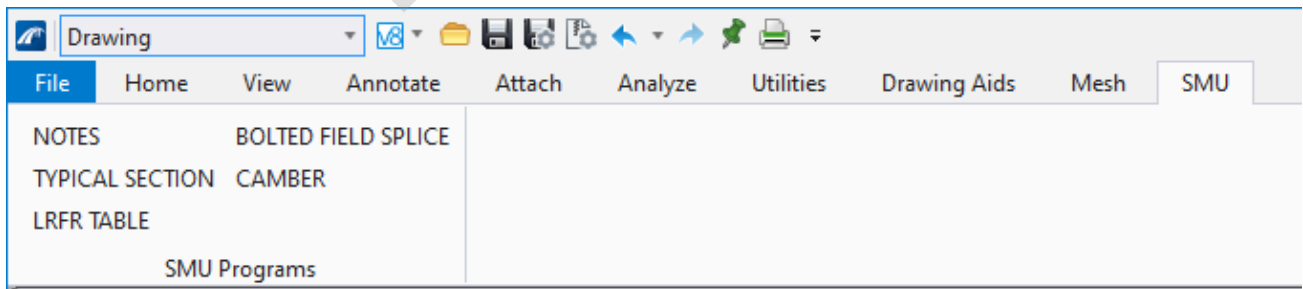

The SMU Program tools are for SMU Staff use with NCBDS design software. These tools can be used in the Sheet Model and used like the SMU Standard Plans.

1.4.6.1 Placing Typical Section From NCBDS

To place Typical Section Drawing, follow these steps.

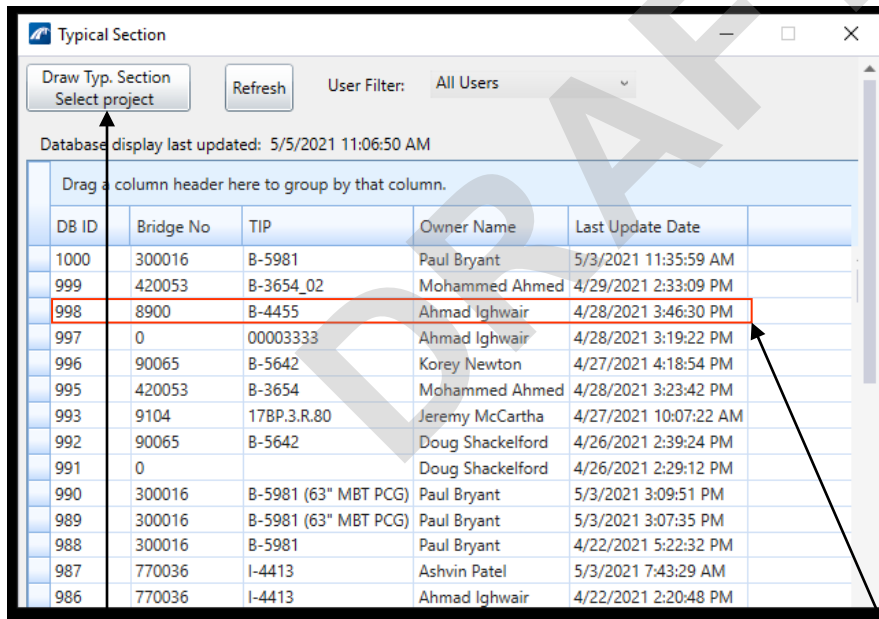
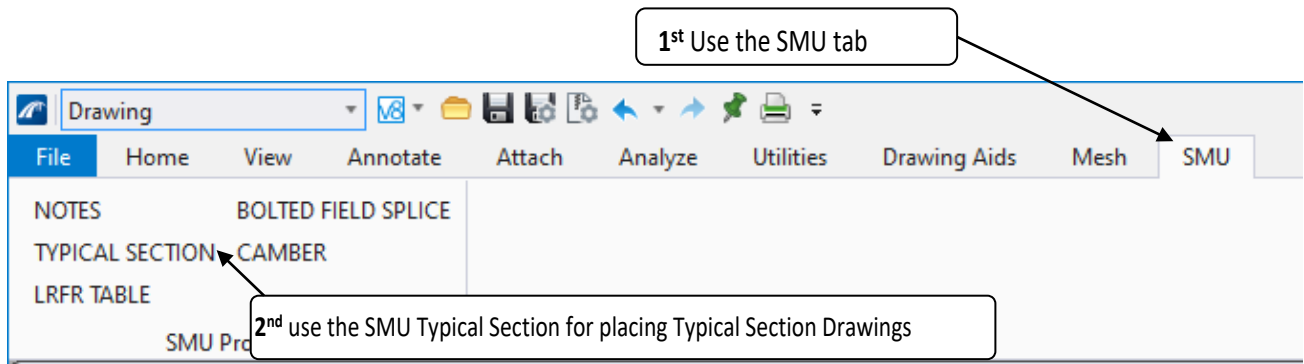

4th Use the "Draw Typ. Section Select Project" button to place the selected typical section in your dgn.

3rd select the desired project from the table.

1.4.6.2 Placing LRFR Summary Table From NCBDS

To place LRFR Table Drawing, follow these steps.

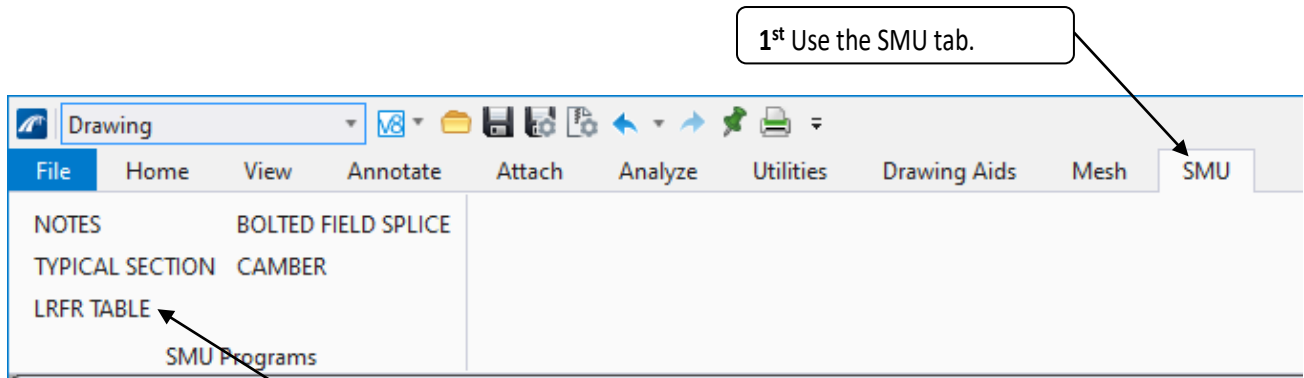

2nd use the "LRFR TABLE" for placing LRFR summary table.

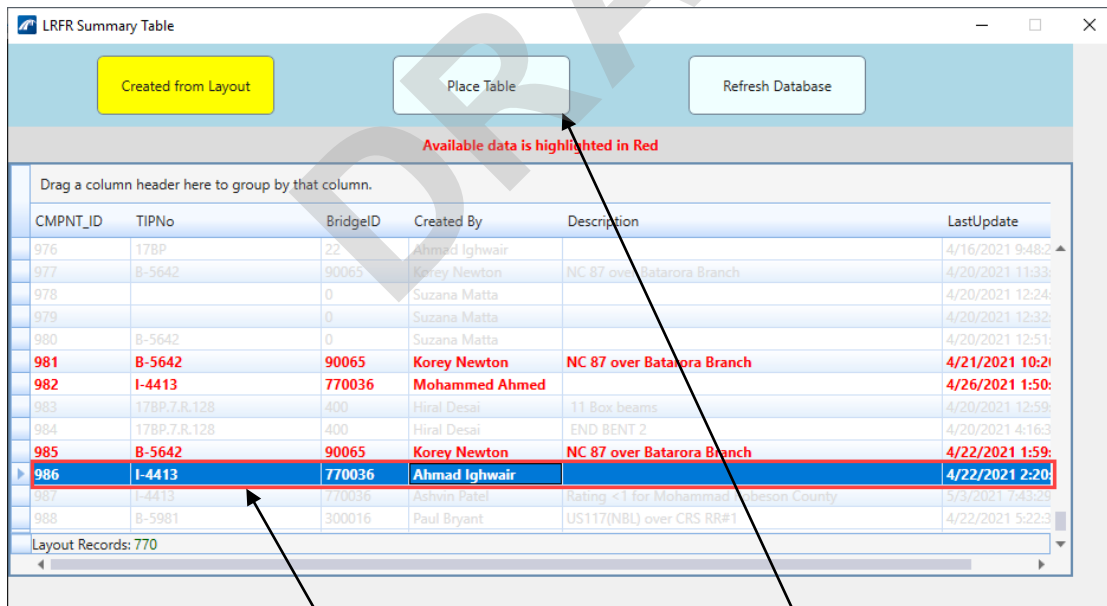

3rd select the desired project from the table.

4th Use the "PLACE TABLE" button to place the latest LRFR table created for the selected project in your dgn.

1.4.6.3 Placing Bolted Field Splice From NCBDS

To place Bolted Field Splice Drawing, follow these steps.

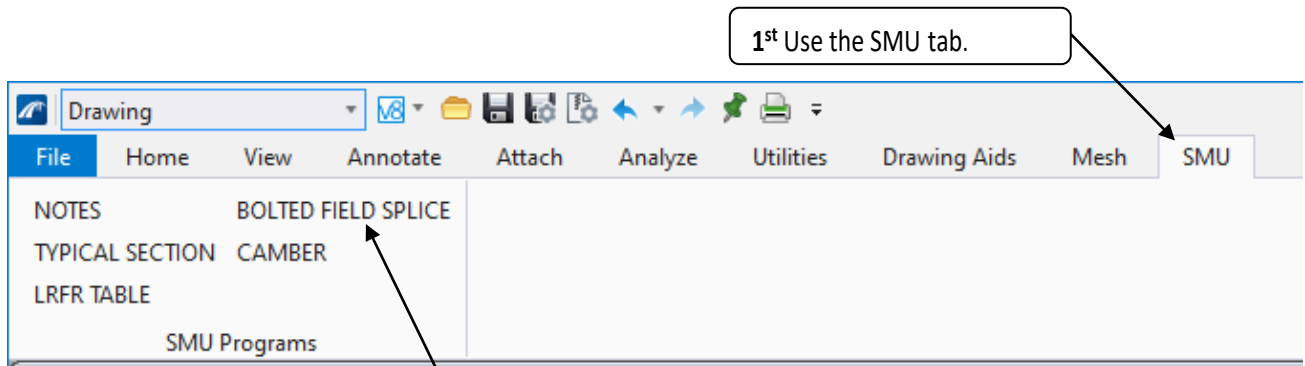

2nd use the "BOLTED FIELD SPLICE" for placing bolted field splice Sketch.

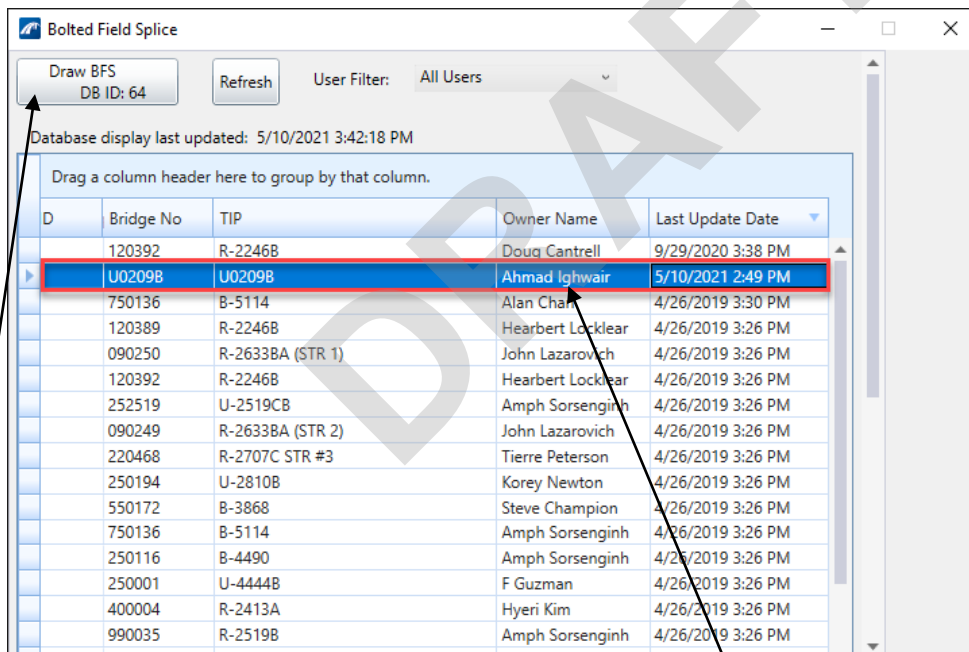

3rd select the desired project from the table.

1.4.7 Bridge Templates

The 3D Bridge Element Template Libraries have been developed to include many of the commonly used NCDOT bridge elements. To modify the element templates, copy the libraries from the workspace into the project Workset folder in ProjectWise and use the tools described in Chapter 6 to edit.

Deck Templates

NCDOT Deck Templates have been established for commonly used deck types.

Template Name	Description
NC AWS w/constraints	Normal crowned asphalt deck
Asphalt Wearing Surface	Asphalt wearing surface for cored slabs and box beams
Cored Slab	Concrete wearing surface for cored slabs and box beams
LT Super Deck w/constraints	Left supered deck with overhangs
NC Deck w/constraints	Normal crowned deck with overhangs
RT Super Deck w/constraints	Right supered deck with overhangs
Timber	Flat timber plank deck

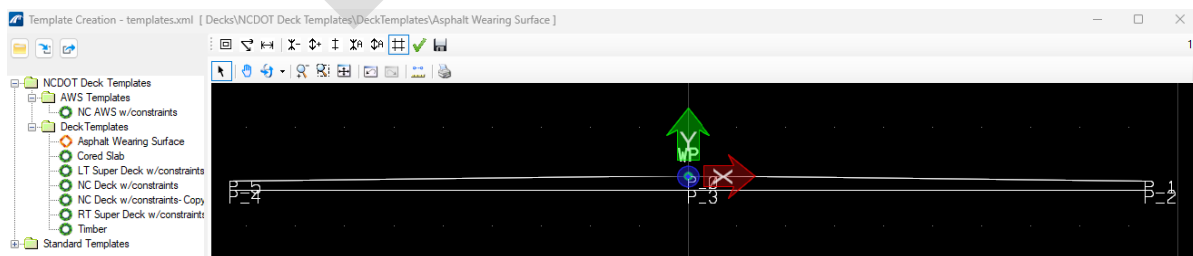

Barriers Templates

NCDOT’s standard bridge rails have templates created to match standard drawings. Note that the metal rails are still a work in progress with the software but the concrete parapets are what is generated.

Template Name	Description	Applicable Standard
1 BMR LT Parapet	Left one bar metal rail	STD NO. BMR 1
1 BMR RT Parapet	Right one bar metal rail	STD NO. BMR 1
2-BMR LT PARAPET	Left two bar metal rail	STD NO. BMR 3&4
2-BMR RT PARAPET	Right two bar metal rail	STD NO. BMR 3&4
2-BMR LT PARAPET w/SIDEWALK	Left two bar metal rail w/sidewalk	STD NO. BMR 3&4 with DM Figure 6-16
2-BMR RT PARAPET w/SIDEWALK	Right two bar metal rail w/sidewalk	STD NO. BMR 3&4 with DM Figure 6-16
3-BMR LT w/ SIDEWALK	Left three bar metal rail	STD NO. BMR 5, 6,&7
3-BMR RT w/ SIDEWALK	Right three bar metal rail	STD NO. BMR 5, 6,&7
8" CURB LT	Left 8" Curb	STD. BAS 1-4
8" CURB RT	Right 8" Curb	STD. BAS 1-4
ALASKA RAIL LT PARAPET 32"	Left Alaska Rail	STD NO. BMR 8&9
ALASKA RAIL RT PARAPET 32"	Right Alaska Rail	STD NO. BMR 8&9
CBR LT 32"	Left concrete barrier rail 32"	STD NO. CBR 1
CBR RT 32"	Right concrete barrier rail 32"	STD NO. CBR 1
CBR LT 42"	Left concrete barrier rail 42"	STD NO. CBR 1
CBR RT 42"	Right concrete barrier rail 42"	STD NO. CBR 1
MEDIAN	Median	DM Figure 6-19
MEDIAN BARRIER	Median barrier	DM Figure 6-27/28
OREGON RAIL LT PARAPET 42"	Left Oregon Rail 42"	STD NO. CBR 10&11
OREGON RAIL RT PARAPET 42"	Right Oregon Rail 42"	STD NO. CBR 10&11
SIDEWALK LT	Left sidewalk	DM Figure 6-16
SIDEWALK RT	Right sidewalk	DM Figure 6-16
TIMBER RAIL LT 42"	Left Timber Rail 42"	STD. TB_BRS
TIMBER RAIL RT 42"	Right Timber Rail 42"	STD. TB_BRS
VERTICAL RAIL LT 42"	Left Vertical Rail 42"	STD NO. CBR 2
VERTICAL RAIL RT 42"	Right Vertical Rail 42"	STD NO. CBR 2

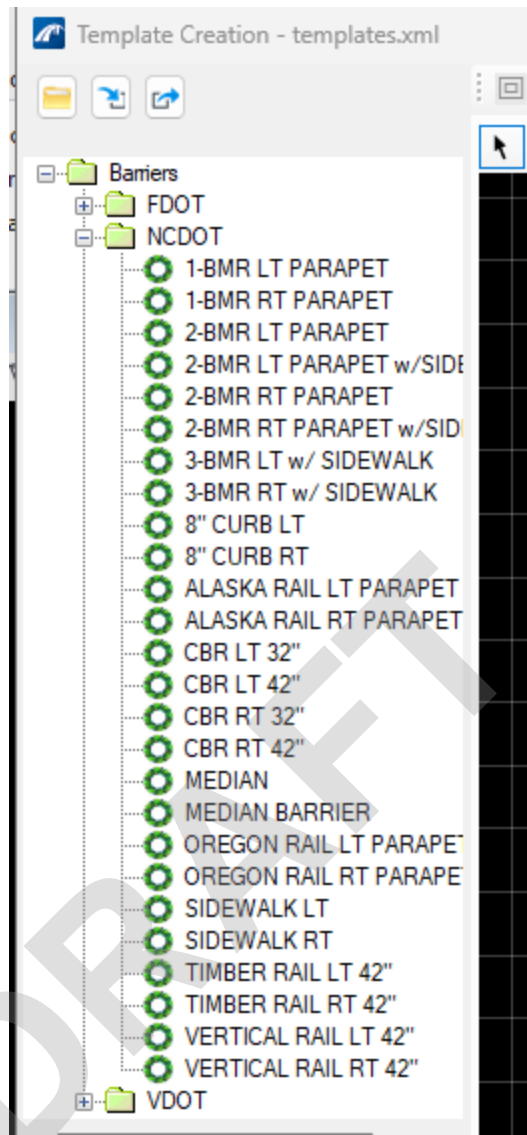

Beam Templates

NCDOT’s standard cored slab and box beam units were created

Template Name	Description	Applicable Standard
18" Cored Slab-Interior	Interior 18" Cored Slab Unit	STD NO. PCS 1
18" Cored Slab-LT Ext	Left Exterior 18" Cored Slab Unit	STD NO. PCS 1
18" Cored Slab-RT Ext	Right Exterior 18" Cored Slab Unit	STD NO. PCS 1
21" Cored Slab-Interior	Interior 21" Cored Slab Unit	STD NO. PCS 2
21" Cored Slab-LT Ext	Left Exterior 21" Cored Slab Unit	STD NO. PCS 2
21" Cored Slab-RT Ext	Right Exterior 21" Cored Slab Unit	STD NO. PCS 2
24" Cored Slab-Interior	Interior 24" Cored Slab Unit	STD NO. PCS 4
24" Cored Slab-LT Ext	Left Exterior 24" Cored Slab Unit	STD NO. PCS 4
24" Cored Slab-RT Ext	Right Exterior 24" Cored Slab Unit	STD NO. PCS 4
27" Box Beam-Interior	Interior 27" Box Beam Unit	STD NO. PCBB 2 & PCBB 3
27" Box Beam-LT Ext	Left Exterior 27" Box Beam Unit	STD NO. PCBB 2 & PCBB 3
27" Box Beam-RT Ext	Right Exterior 27" Box Beam Unit	STD NO. PCBB 2 & PCBB 3
33" Box Beam-Interior	Interior 33" Box Beam Unit	STD NO. PCBB 4 & PCBB 5
33" Box Beam-LT Ext	Left Exterior 33" Box Beam Unit	STD NO. PCBB 4 & PCBB 5
33" Box Beam-RT Ext	Right Exterior 33" Box Beam Unit	STD NO. PCBB 4 & PCBB 5
39" Box Beam-Interior	Interior 39" Box Beam Unit	STD NO. PCBB 6 & PCBB 7
39" Box Beam-LT Ext	Left Exterior 39" Box Beam Unit	STD NO. PCBB 6 & PCBB 7
39" Box Beam-RT Ext	Right Exterior 39" Box Beam Unit	STD NO. PCBB 6 & PCBB 7
AASHTO Type II Girder	36" AASHTO Girder - Standard Section	STD NO. PCG 1
AASHTO Type III Girder	45" AASHTO Girder - Standard Section	STD NO. PCG 2
AASHTO Type IV Girder	54" AASHTO Girder - Standard Section	STD NO. PCG 3
63" Modified Bulb Tee Girder	63" Modified Bulb Tee Girder	STD NO. PCG 7
72" Modified Bulb Tee Girder	72" Modified Bulb Tee Girder	STD NO. PCG 8
36" FIB Girder	36" Florida I-Beam Girder	STD NO. FIB36
45" FIB Girder	45" Florida I-Beam Girder	STD NO. FIB45
54" FIB Girder	54" Florida I-Beam Girder	STD NO. FIB54
63" FIB Girder	63" Florida I-Beam Girder	STD NO. FIB63
72" FIB Girder	72" Florida I-Beam Girder	STD NO. FIB72
78" FIB Girder	78" Florida I-Beam Girder	STD NO. FIB78
84" FIB Girder	84" Florida I-Beam Girder	STD NO. FIB84

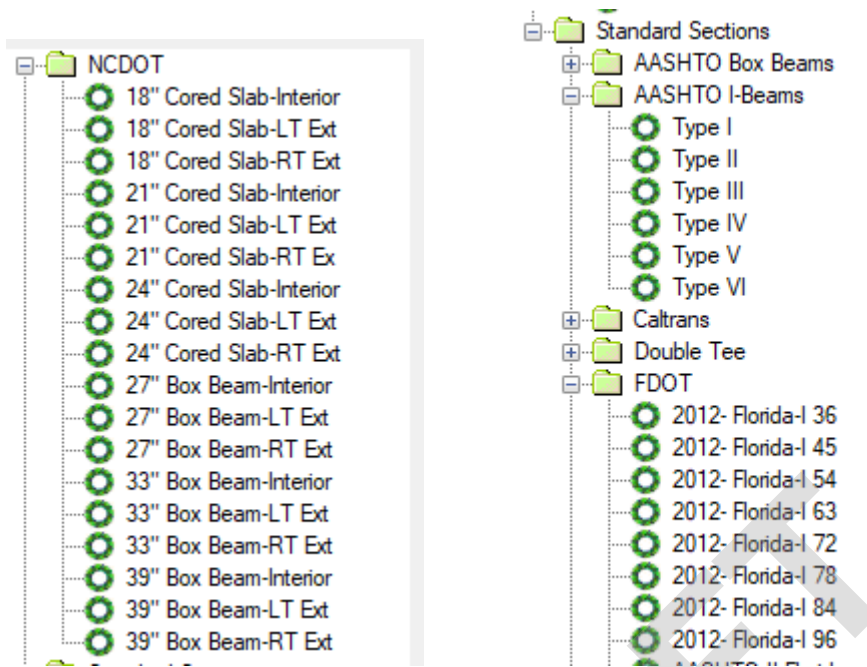

1.5 ACRONYMS AND ABBREVIATIONS

2D	Two dimensional
3D	Three dimensional
4D	Four dimensional
ALG	NCDOT Roadway Alignment File
BrIM	Bridge Information Modeling
CADD	Computer-aided design and drafting
ECTM	Existing Complex Terrain Model
LOD	Level of Development
NCDOT	North Carolina Department of Transportation
ORD	OpenRoads Designer
OBD	OpenBridge Designer
OBM	OpenBridge Modeler
PGD	Preliminary General Drawing
PW	ProjectWise
SMU	Structures Management Unit

CONTENTS

Chapter 2.....2-1

 2.1 Project Management Considerations2-1

 2.1.1 Project Scoping (PDN 2ST1).....2-1

 2.1.2 Project Workflow.....2-1

 2.1.3 Project Deliverables.....2-1

 2.2 File Storage.....2-3

 2.2.1 ProjectWise Explorer Guidance2-3

 2.2.2 Structures ProjectWise Folder Structure2-3

 2.2.3 Structures Folder Naming Convention2-4

 2.2.4 Storing Files within the Structure Folder.....2-5

 2.3 File Naming Conventions2-6

DRAFT

CHAPTER 2

PROJECT MANGEMENT

2.1 PROJECT MANAGEMENT CONSIDERATIONS

2.1.1 Project Scoping (PDN 2ST1)

As NCDOT and SMU continue to advance use of the OpenX software, it is important the project team is aware of what the project expectations are for the project task during the project scoping meeting.

2.1.2 Project Workflow

Each project scoping meeting should include project team members for all disciplines of work involved with the design to determine the following:

- The stage in the design process where the structure model/PGD is required.
- How ProjectWise will be used to share live DGN files between disciplines.
- How culverts will be modeled and who is responsible for creating the stream alignment.
- How the bridge slopes and slope protection will be created by either Roadway or Hydraulics.
- If there are retaining walls in-front of and/or beside the structure, who (Roadway or Geotechnical) will create models for them based on Structures provided cap/wing wall elevations and offsets.

2.1.3 Project Deliverables

The NCDOT Project Manager responsible for the entire project should make the project team members aware of what project deliverables are, and if a 3D Structural Model is required and what level of development (LOD) for the 3D model is required for each structure. Project Teams should leave scoping meetings knowing what types of the following deliverables are required (note: all PDFs are submitted via SharePoint and all DGNs should be submitted in ProjectWise):

PDN 2ST2 Preliminary General Drawings Submittal

First Submittal

- 2D PGD (PDF).
- Preliminary 3D Structural Digital Twin (DGN) (if applicable).
- Preliminary Header Elevations (if applicable).
- Vertical Abutment Wall Envelopes (if applicable).

Final Submittal

- 2D PGD (PDF & DGN).

- Preliminary 3D Structural Digital Twin (DGN) (if applicable).
- Preliminary Header Elevations (if applicable).
- Vertical Abutment Wall Envelopes (if applicable).

PDN 3ST1 Complete Structures Design

- Geotechnical Foundation Loads.
- Access Drawings.
- Coast Guard Permit Sketches (if applicable).
- Railroad Easement Sketches (if applicable).
- Permit Impacts.

90% Structures Design Submittal

- Final 2D Structure Plans (PDF).
- Final 3D Structural Digital Twin (DGN) (if applicable)
- Project Special Provisions Package (PDF).
- Working Day Calculations (PDF).

PDN 4ST1 Finalize Structure Design PS&E

100% Structure Design

First Submittal

- 2D Structure Plan Sheets Combined (PDF).
- 3D Structural Digital Twin (DNG) (if applicable).
- Structures Project Special Provisions Package (PDF).
- Structure Pay Items & Quantities (PIQ).

Final Submittal

- PE Sealed and E-Signatures, 2D Individual Structure Plan Sheets (PDF).
- 2D Structure Plan Files without PE Seals (DGN).
- Final 3D Structural Digital Twin (DNG) (if applicable).
- PE Sealed and E-Signatures Structure Design Calculations (PDF).
- PE Sealed and E-Signatures Structures Project Special Provisions Package (PDF).
- Bridge Construction Elevations (PDF).

PDN 5ST1 Structure Construction Support

- Perform construction revisions to address identified 3D model (if applicable)/2D plan errors or field changes initiated by NCDOT or the Contractor.

2.2 FILE STORAGE

As per the [Chief Engineer's Memo](#), moving forward all project files, other than confidential documents, should be stored within NCDOT's ProjectWise Explorer. All structures related DGNs and sealed design calculations shall be housed in the "Structures" folder under its respective project folder. Files should be created using the SMU naming convention and include the appropriate metadata to make the file searchable in the future.

2.2.1 ProjectWise Explorer Guidance

ProjectWise guidance documents for creating, saving, searching and exporting documents can be found here <https://connect.ncdot.gov/resources/CADD/Pages/ProjectWise.aspx>.

All ProjectWise project folders will be set up by the NCDOT Project Manager through SharePoint. Adding structures on the project in SharePoint will generate a folder for each structure under the "Structures" main folder overnight. If a project does not have the correct structure folders in ProjectWise, contact the NCDOT Project Manager.

2.2.2 Structures ProjectWise Folder Structure

The folder structure for the "Structures" project work has been predetermined and set to allow the Department of Information Technology (DIT) to manage and maintain it from an administrative level. When the project folder is created the template will create a "Structures" folder which will have the structures folders listed (such as "BRG" and "CUL" folders) with three subfolders; "Design," "PDF," and "Plans."

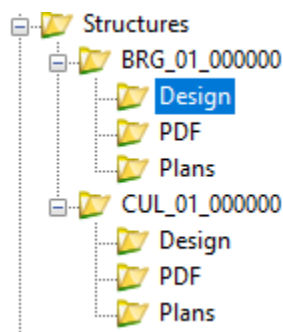

The structure folders, such as "BRG" and "CUL," may not be copied to create additional structure folders for a project, this must be done using SharePoint. If edits need to be made to a project folder, such as adding or removing structures from a project, this should be done in SharePoint and the corresponding updates will be made overnight within

ProjectWise. Project Engineers should make sure that the correct structure type ID’s are being used within SharePoint and ProjectWise to ensure correct workflow when the project is moved from PreConstruction to Construction within SharePoint. Also, the “Design” “PDF” and “Plans” subfolders should not have their names edited, nor should other subfolders be added.

2.2.3 Structures Folder Naming Convention

When the project is created in SharePoint, the ProjectWise structure folders will be automatically generated the following day. If the folder naming convention does not match the following, contact dot.pwsupport@ncdot.gov

Naming convention: **Structure Type ID_##_SMU 6-digit NBI ID**

Structure Type ID =	Bridge	BRG
	Culvert	CUL
	High Mast Lighting	HML
	Noise Wall	NW
	Other	OT
	Overhead Sign	OS
	Penstock	PS
	Retaining Wall	RW
	Temporary Structure	TMP

= the structure numbering used on the plans for multiple structures on a project (i.e. STR#01, STR#02, etc.). Construction uses these to identify the structures in the field and our folders will now roll over to the Construction side of SharePoint.

SMU 6-digit NBI ID = the structure ID SI&A gives a structure that is inspected and reported to FHWA for NBIS compliance

2.2.4 Storing Files within the Structure Folder

Files should be stored within the Structure project folder structure as follows:

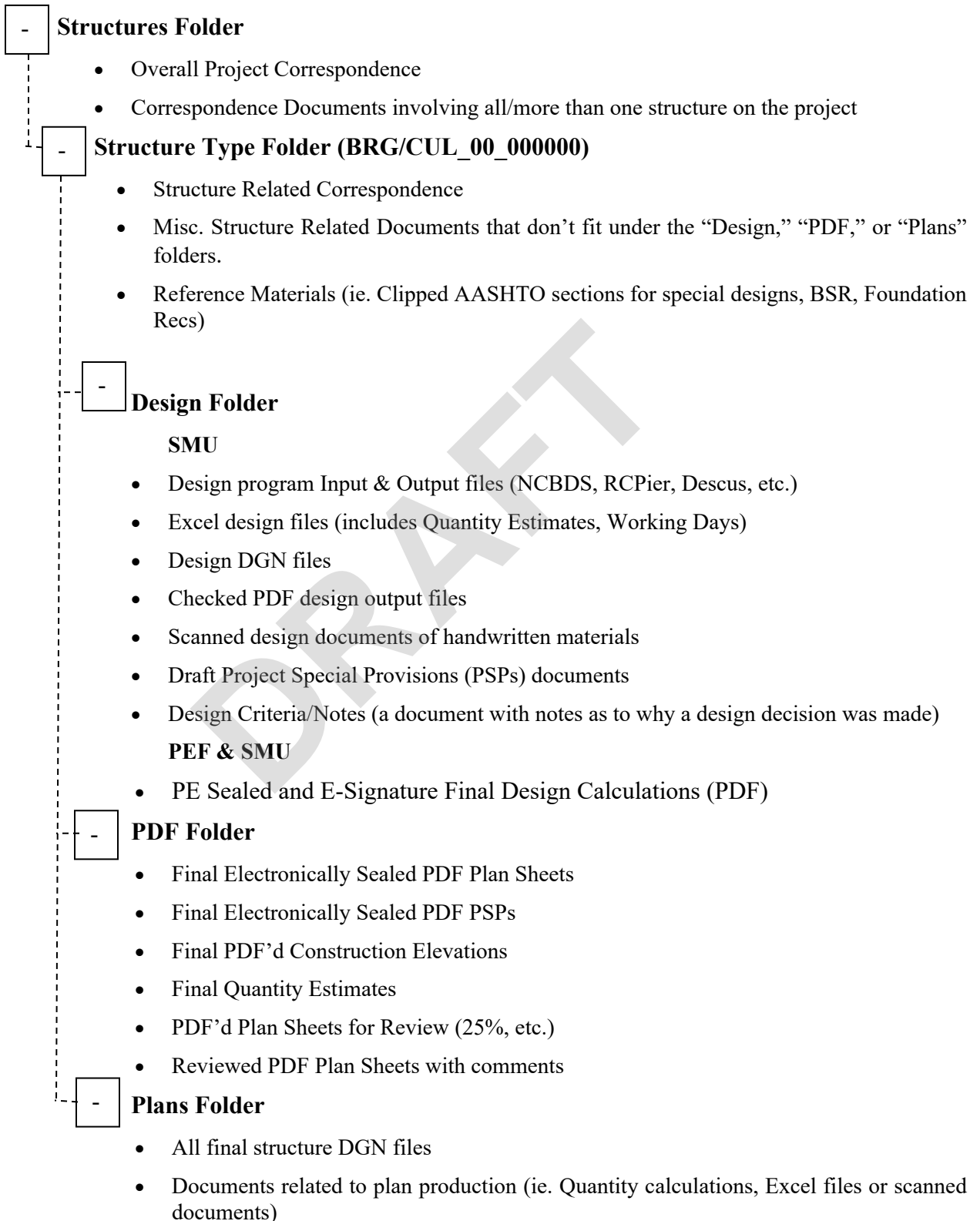

2.3 FILE NAMING CONVENTIONS

Each plan sheet shall be its own DGN and PDF file and follow this naming convention:

Models shall be named **4XX_000_TIP#_SMU_BR#_MODEL_6digitStrID**

TIP Number with no hyphenations (" - ") ie. B5121

Plan sheet number, ie. Sheet 1 of structure 1 would be S1-01

4XX_###_TIP#_SMU_FileDescript_Sheet#_6digitStrID

Abbreviation of the drawing type using the file descriptions

All Structure files are in the 400 series of files:

- Master Project Structure's Title Sheets and Index Sheets are 400, note leave off the 6-digit structure ID off these files
- Bridges: STR#1 thru STR#9 on the project start 401 thru 409
- Culverts: CU#1 thru CU#9 on the project start at 410 thru 419, unless there are more than 9 structures on the project...then use the next available number
- Walls: W#1 thru W#9 on the project start at 420-429 unless there are more bridges or culverts

Electronic page number for the particular bridge (each bridge set starts at 001 and successive numbers are all odd, ie. 001, 003, 005...) to allow for any future addendums

FILE DESCRIPTIONS			
1MR	ONE BAR METAL RAIL SHEETS	GRD	GRDNER REPAIR DETAIL SHEETS
2MR	TWO BAR METAL RAIL SHEETS	DM	INCIDENTAL MILLING SHEETS
3MR	THREE BAR METAL RAIL SHEETS	IS	INDEX OF MULTI-STRUCTURE PROJECTS SHEETS
AB	ABUTMENT SHEETS	JD	BRIDGE JACKING DETAIL SHEETS
AR	ALASKA RAIL SHEETS	JS	JOINT SEAL SHEETS
AS	APPROACH SLAB SHEETS	JT	JOINT DETAIL SHEETS
B1, B2...Bn	BENT SHEETS	LC	LONG CORD LAYOUT SHEETS
BB	BOX BEAM SHEETS	LS	LOCATION SKETCH SHEETS
BG	BEARING SHEETS	MD	CONCRETE MEDIAN SHEETS
BK	BULKHEAD SHEETS	OR	OREGON RAIL SHEETS
BM	SUPERSTRUCTURE BILL OF MATERIAL SHEETS	PC	STAGE OF PHASE CONSTRUCTION SHEETS
BR	BARRIER RAIL SHEETS	PGD	PRELIMINARY GENERAL DRAWING SHEETS
CG	COAST GUARD PERMIT SHEETS	PP	PRESTRESSED CONCRETE PILE SHEETS
CS	CORED SLAB SHEETS	RF	RAIL RETROFIT SHEETS
CU	CULVERT SHEETS	RR	RIP-RAP SHEETS
DL	DEAD LOAD DEFLECTION TABLE SHEETS	RW	RETAINING WALL DETAIL SHEETS
DP	PRESTRESSED DECK PANEL SHEETS	S1, S2...Sn	PLAN OF SPAN SHEETS
DSR	DECK SURFACE REPAIR SHEETS	SN	STANDARD NOTES SHEET
DT	DETOUR SHEETS	SP	SLOPE PROTECTION SHEETS
DUR	DECK UNDERSIDE REPAIR SHEETS	SS	STRUCTURAL STEEL DETAIL SHEETS
E1, E2...En	END BENT SHEETS	SSR	STRUCTURAL STEEL REPAIR SHEETS
FL	FOUNDATION LAYOUT SKETCH SHEETS	SW	SIDEWALK DETAIL SHEETS
FP	FRAMING PLAN LAYOUT SHEETS	TA	TEMPORARY ACCESS SHEETS
G1, G2...Gn	PRESTRESSED CONCRETE GIRDER SHEETS	TS	SUPERSTRUCTURE TYPICAL SECTION SHEETS
GD	GENERAL DRAWING SHEETS	UT	UTILITIES DETAILS SHEETS
GR	GUARDRAIL ATTACHMENT SHEETS		

6-digit structure ID's XX####
XX =County Number + #### Structure Number

XX - County Numbers		
00 - ALAMANCE	34 - FRANKLIN	68 - PAMLICO
01 - ALEXANDER	35 - GASTON	69 - PASQUOTANK
02 - ALLEGHANY	36 - GATES	70 - PENDER
03 - ANSON	37 - GRAHAM	71 - PERQUIMANS
04 - ASHE	38 - GRANVILLE	72 - PERSON
05 - AVERY	39 - GREENE	73 - PITT
06 - BEAUFORT	40 - GUILFORD	74 - POLK
07 - BERTIE	41 - HALIFAX	75 - RANDOLPH
08 - BLADEN	42 - HARNETT	76 - RICHMOND
09 - BRUNSWICK	43 - HAYWOOD	77 - ROBESON
10 - BUNCOMBE	44 - HENDERSON	78 - ROCKINGHAM
11 - BURKE	45 - HERTFORD	79 - ROWAN
12 - CABARRUS	46 - HOKE	80 - RUTHERFORD
13 - CALDWELL	47 - HYDE	81 - SAMPSON
14 - CAMDEN	48- IREDELL	82 - SCOTLAND
15 - CARTERET	49 - JACKSON	83 - STANLY
16 - CASWELL	50 - JOHNSTON	84 - STOKES
17 - CATAWBA	51 - JONES	85 - SURRY
18 - CHATHAM	52 - LEE	86 - SWAIN
19 - CHEROKEE	53 - LENOIR	87 - TRANSYLVANIA
20 - CHOWAN	54 - LINCOLN	88 - TYRRELL
21 - CLAY	55 - MACON	89 - UNION
22 - CLEVELAND	56 - MADISON	90 - VANCE
23 - COLUMBUS	57 - MARTIN	91 - WAKE
24 - CRAVEN	58 - MCDOWELL	92 - WARREN
25 - CUMBERLAND	59 - MECKLENBURG	93 - WASHINGTON
26 - CURRITUCK	60 - MITCHELL	94 - WATAUGA
27 - DARE	61 - MONTGOMERY	95 - WAYNE
28 - DAVIDSON	62 - MOORE	96 - WILKES
29 - DAVIE	63 - NASH	97 - WILSON
30 - DUPLIN	64 - NEW HANOVER	98 - YADKIN
31 - DURHAM	65 - NORTHHAMPTON	99 - YANCEY
32 - EDGECOMBE	66 - ONSLOW	
33 - FORSYTH	67- ORANGE	

CONTENTS

Chapter 3.....1

3.1 Opening Openbridge Designer1

3.2 OBD File Creation In ProjectWise2

3.2.1 Connecting OBD to ProjectWise.....2

3.2.2 Creating a New OBDX File.....3

3.2.3 DGN Creation In ProjectWise5

3.2.3.1 BIM Project Workflow (2D Plans).....5

3.2.3.2 Creating a DGN in BIM Workflow6

3.2.3.3 Standalone Project Workflow (2D Drawings & 3D Model)7

3.2.3.4 Creating a DGN in Standalone Workflow8

3.2.4 DGN Creation in ProjectWise9

3.3 Opening an Existing DGN in BIM Workflow.....16

3.3.1 Open OBD file Browser16

3.3.2 Select the Project .obdx file16

3.3.3 Select and Open Existing DGN16

3.4 Creating a New DGN in an Existing Project in BIM Workflow17

3.5 Opening Leap Design Software.....18

3.6 OBD DGN Workflow.....19

3.7 DGN Models.....20

3.7.1 Models Dialog21

3.7.1.1 Design Models22

3.7.1.2 Drawing Models24

3.7.1.3 Sheet Models25

3.8 Civil Tools27

3.8.1 Civil Analysis Point Tool27

3.8.1.1 Finding Stations, Elevations and Offsets along an Alignment27

3.8.1.2 Finding Elevations along the Terrain28

3.8.2 Horizontal Geometry Tools29

3.8.2.1 Point.....29

3.8.2.2 Offsetting Roadway Alignments31

3.8.2.3 Creating an Horizontal Alignment.....32

3.8.3 Vertical Geometry Tools35

3.8.3.1 Adding Vertical Geometry to an Alignment35

3.9 Place Named Boundary Tool.....39

3.10 Spacebar.....40

3.11 Background Map40

3.12 Custom Line Styles.....41

3.13 Skews.....42

3.14 Drawing Scales43

CHAPTER 3

INTRODUCTION TO OPENBRIDGE DESIGNER

3.1 OPENING OPENBRIDGE DESIGNER

To use OpenBridge Designer (OBD), locate and click on the icon shown below to open the software.



Once opened, the following splash screen will appear:

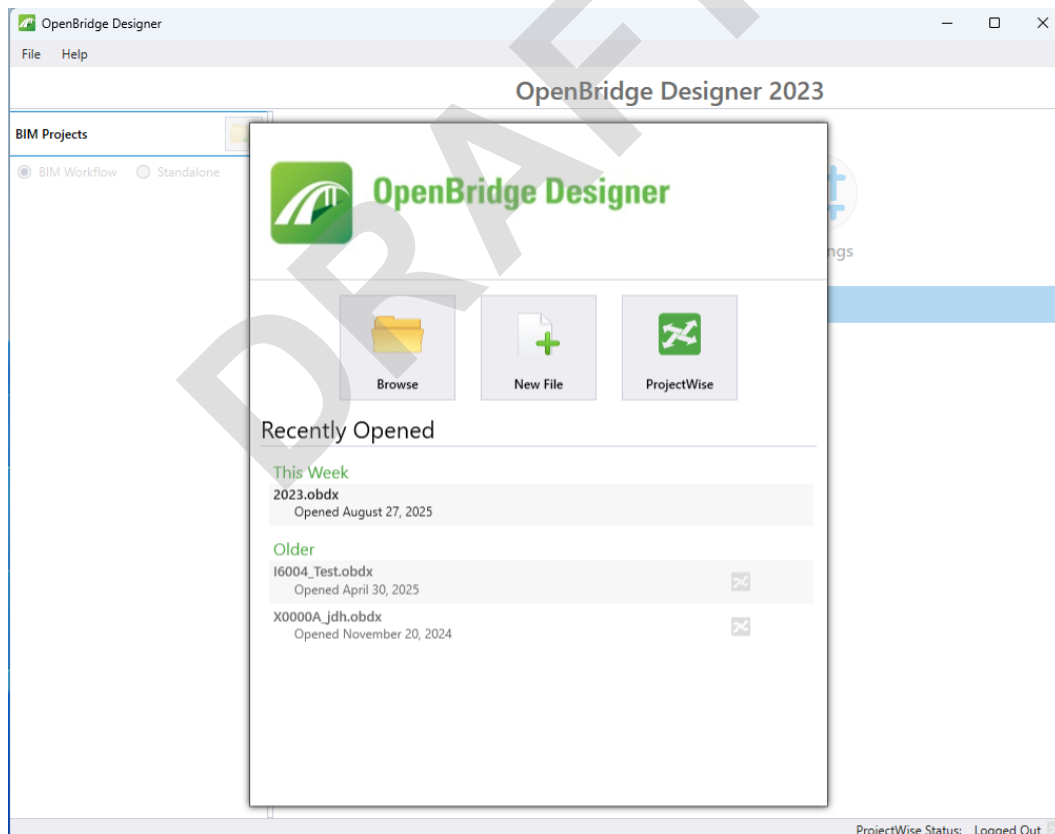

From here the user can browse to a DGN file, create a new DGN file, or connect OBD to ProjectWise (PW) to browse to an existing DGN file in PW or create a new DGN file in PW.

3.2 OBD FILE CREATION IN PROJECTWISE

Prior to creating a dgn file, a project folder must be created in ProjectWise for storage. If there is no project folder or structures bridge specific subfolder(s) in PW (see Section 2.2.2), contact your NCDOT Project Manager.

3.2.1 Connecting OBD to ProjectWise

On the OBD splash screen

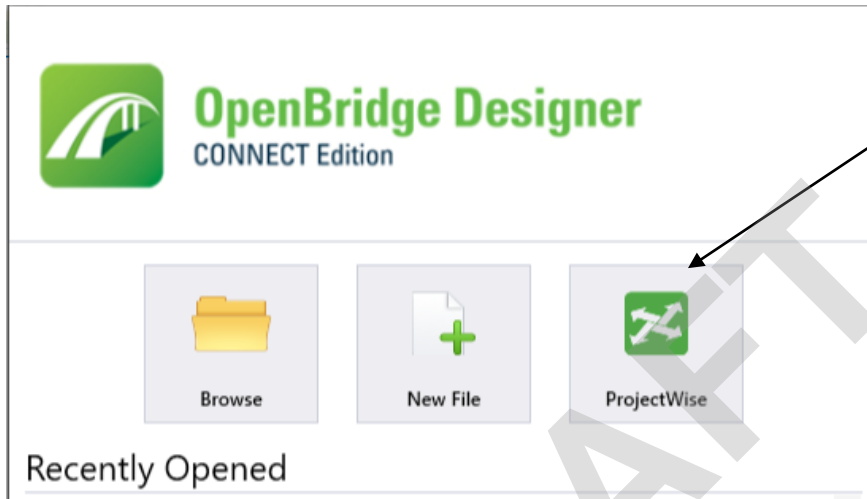

To create a new file in ProjectWise, click on "ProjectWise"

A prompt for ProjectWise will open at this step

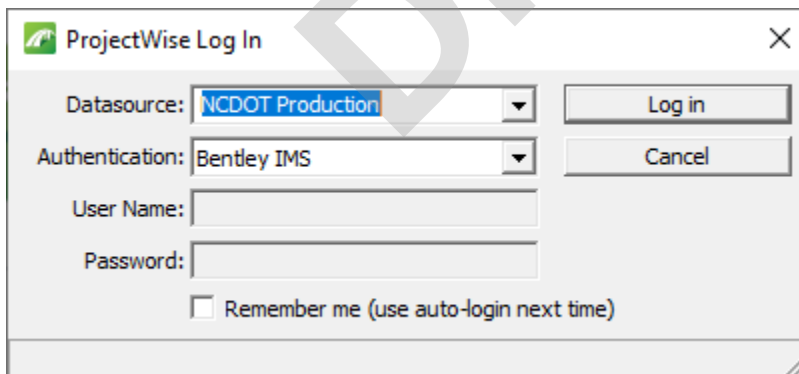

Make sure the Datasource is set to "NCDOT Production" and Authentication is "Bentley IMS", then click on "Log in"

For how to create files and use ProjectWise, look at CADD Services' website

<https://connect.ncdot.gov/resources/CADD/Pages/ProjectWise.aspx>

To continue creating a file outside of ProjectWise click on the "Cancel" button and move to the next section.

3.2.2 Creating a New OBDX File

Once OBD is logged into ProjectWise you will see the following window.

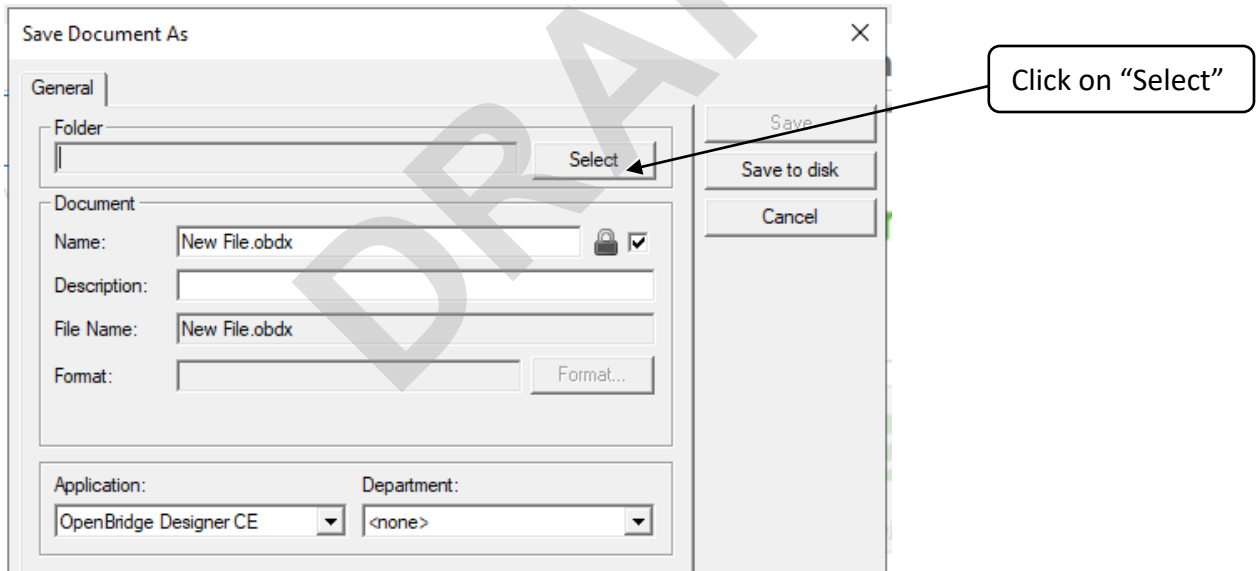
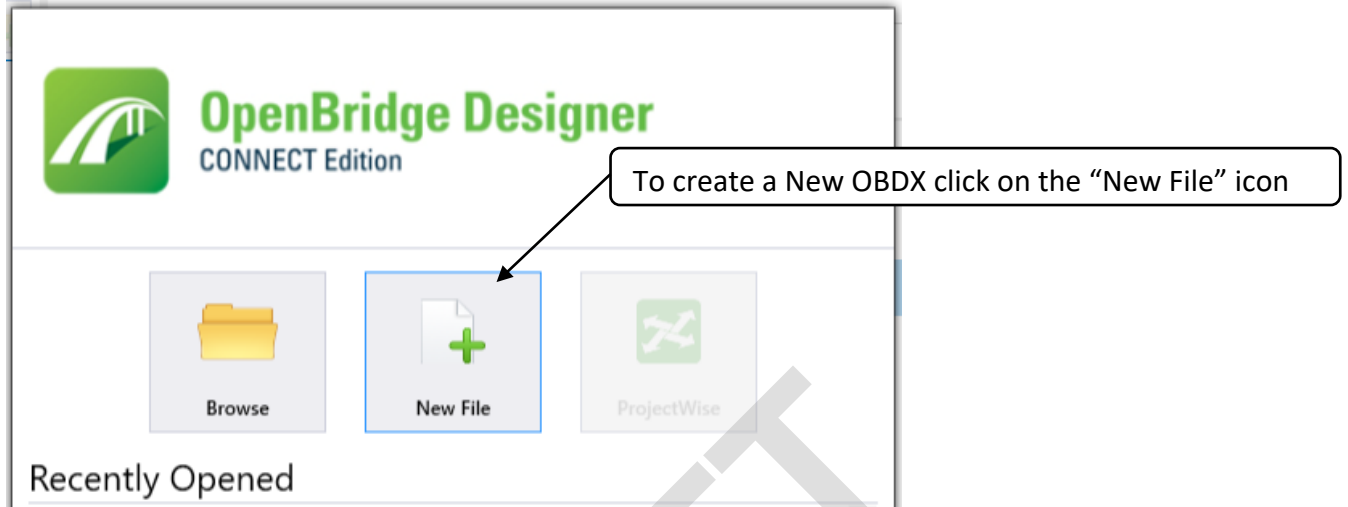

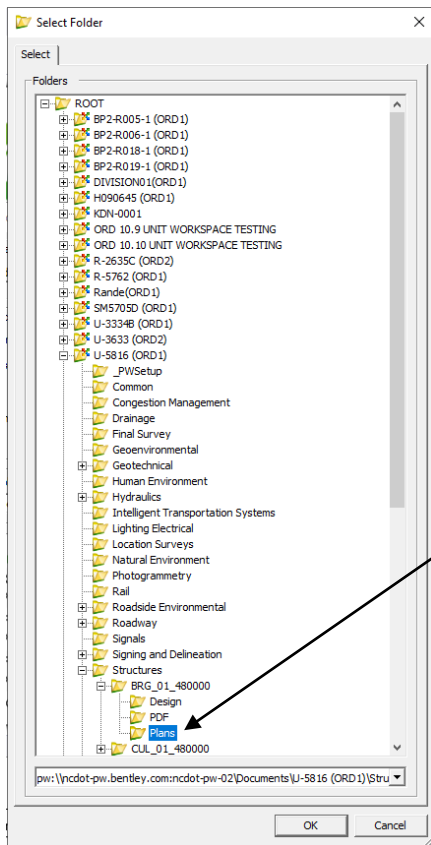

Navigate to the structure folder and select the "Plans" folder, and click "OK"

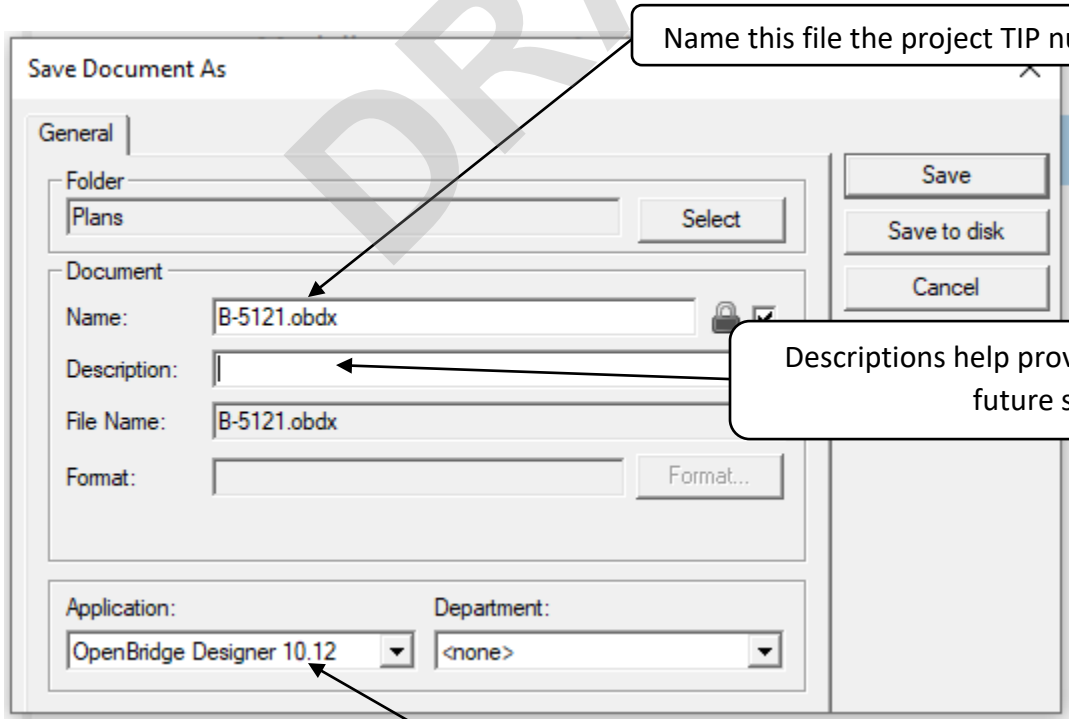

Name this file the project TIP number, ie. B-5121

Descriptions help provide more metadata for future searches.

Select "OBD 2023" from the drop down.

Once all fields are entered, click “Save” to create the OBDX

Note: Each structure on the project will have a OBDX file for both the design and the plans that will need to be created.

3.2.3 DGN Creation In ProjectWise

3.2.3.1 BIM Project Workflow (2D Plans)

This workflow is not recommended, but is an option for strictly doing 2D drawings using old v8 SMU files, as well as Survey and Roadway files.

The screenshot shows the OpenBridge Designer CONNECT Edition interface. On the left, the 'BIM Projects' panel is visible with a '+ New Folder' icon. Below it, there are radio buttons for 'BIM Workflow' (selected) and 'Standalone', and a link 'Add project to begin'. The main workspace shows a workflow diagram with four stages: Modeling, Analysis, Drawings, and Interop. A blue bar is present below the diagram with the text 'Select a bridge model or unit'. Two callout boxes provide instructions: one points to the '+ New Folder' icon, and another points to the 'BIM Workflow' radio button.

Once a BIM workflow is selected, click the “New Folder” Icon

BIM workflow is used for drawings only, use this for creating **2D plans**

Name the subfolder for DGN’s the structure number:

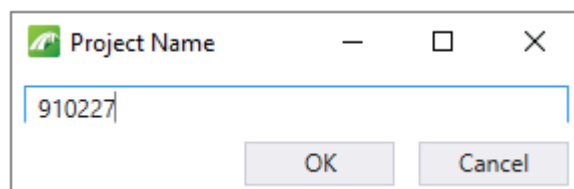

3.2.3.2 Creating a DGN in BIM Workflow

The image shows a screenshot of the OpenBridge Designer software interface. The main window is titled "ProjectName.obd - OpenBridge Designer" and displays the "CONNECT Edition" workflow. The workflow consists of four stages: Modeling, Analysis, Drawings, and Interop. The "Modeling" stage is currently selected and highlighted in blue. In the left-hand "BIM Projects" pane, a project named "910227" is expanded to show a model named "New Bridge Model" with the status "File Not Created". A callout box with the text "1st Right click on the model, and click on 'Rename'" has an arrow pointing to the "New Bridge Model" entry. Below the main interface, a "Rename Bridge Mo..." dialog box is open, showing the current name "New Bridge Model" in a text field, with "OK" and "Cancel" buttons. A callout box with the text "2nd Name your model ie 'GD01'" has an arrow pointing to the text field. To the right of the main interface, a callout box with the text "3rd To create a new dgn file click here" has an arrow pointing to the "OpenBridge Modeler" icon, which is also labeled "File Not Created" and "Run application to begin."

Continue creating a DGN with Sections 4.2.7-4.2.9

3.2.3.3 Standalone Project Workflow (2D Drawings & 3D Model)

This workflow is recommended for all projects that will use ORD reference files, and/or the LEAP design software.

The screenshot shows the OpenBridge Designer CONNECT Edition interface. On the left, the 'Standalone File Groups' panel is active, with 'Standalone' selected and 'Standalone Group : 910227' listed. The main workspace displays a workflow diagram with four stages: Modeling, Analysis, Drawings, and Interop. The 'Modeling' stage is highlighted with a blue bar. Below this bar, a warning message is displayed: 'OpenBridge Modeler' with a file icon, 'File Not Created', and 'Run application to begin.' A callout box points to the 'Standalone' option in the file groups panel.

Standalone workflow is used for creating digital twin models capable of exchanging model data with design software, **3D model creation and using Leap Design Products.**

3.2.3.4 Creating a DGN in Standalone Workflow

1st Right click on "Create Standalone File Group"

3rd To create a new dgn file click here

2nd Name your model group ie "Structure ID"

The following window will pop-up:

3rd Link to the "NCDOT Production" Database and use the "Bentley IMS" Authentication to Log in

Continue creating a DGN with Sections 4.2.8-4.2.10.

3.2.4 DGN Creation in ProjectWise

NCDOT Staff will see:

OpenBridge Modeler CONNECT Edition

DOT-US North Carolina ▾ SMU Workset ▾

Recent Files

You haven't opened any files recently. To browse for a file, start by clicking on Browse.

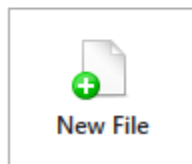
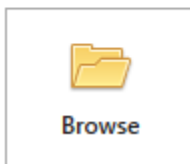

Select "DOT-US North Carolina" Workspace and "SMU Workset"

Then, Click "New File"

Consultants will see:

OpenBridge Modeler CE

WorkSpace WorkSet
Imperial Standards ▾ Tutorial 1 ▾

Recent Files

You haven't opened any files recently. To browse for a file, start by clicking on Browse.

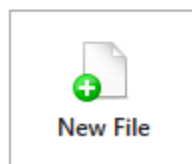
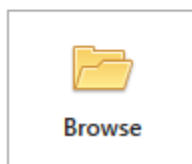

Then, Click "New File"

The following window will pop-up:

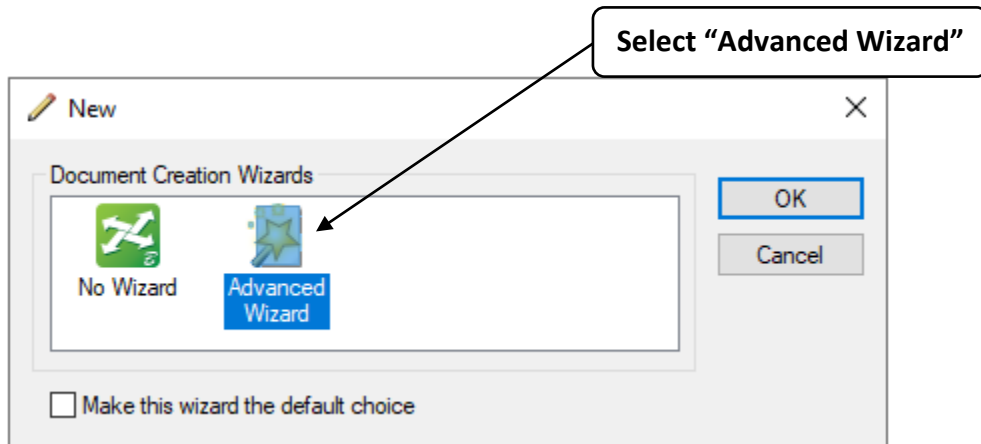

Note: The Advanced Wizard has replaced the NCDOT Design File Generator

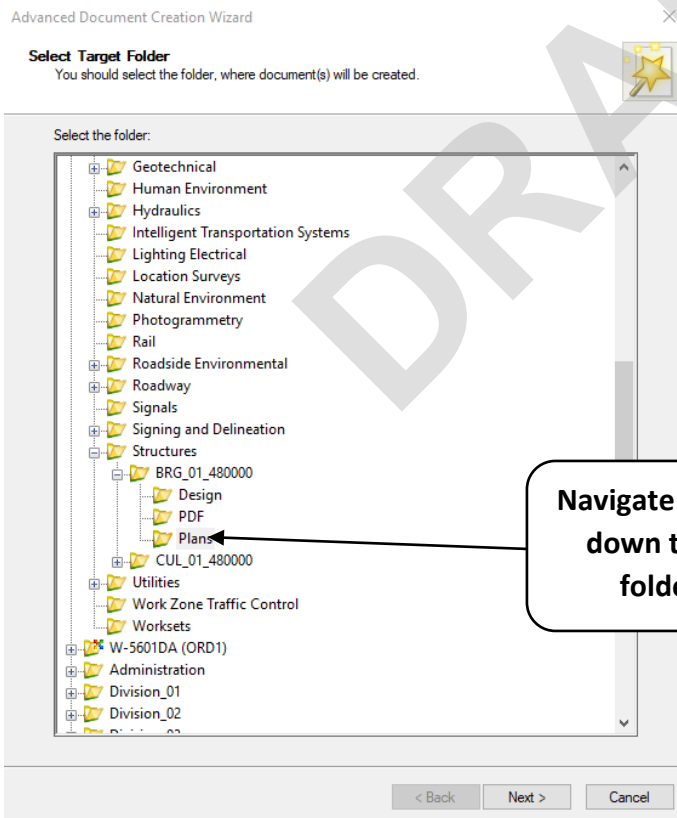

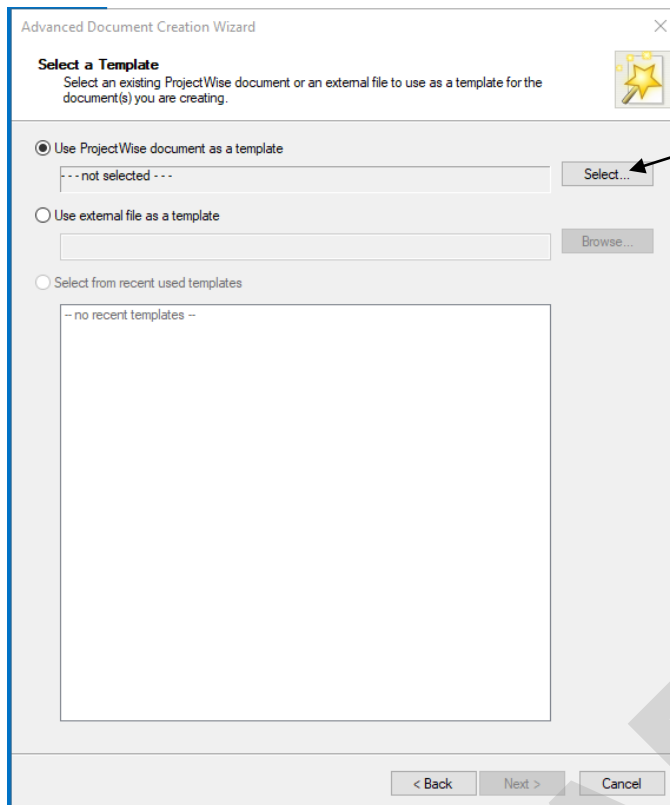

Use the ProjectWise document template.

The SMU seed file is located here with ProjectWise:
 NCDOTProduction/Documents/Administration/WorkspaceGroups/NCDOTWorkspaces/Configuration_2023/Workspaces/DOT-US North Carolina/Roles/NCDOT_Structures/Standards/Seed

Note: The user only needs to select this one time, after that the seed file path will show up in the bottom "Select from recent used templates" box. To use it, just select the button next to "Select from recent used templates" and highlight the seed file.

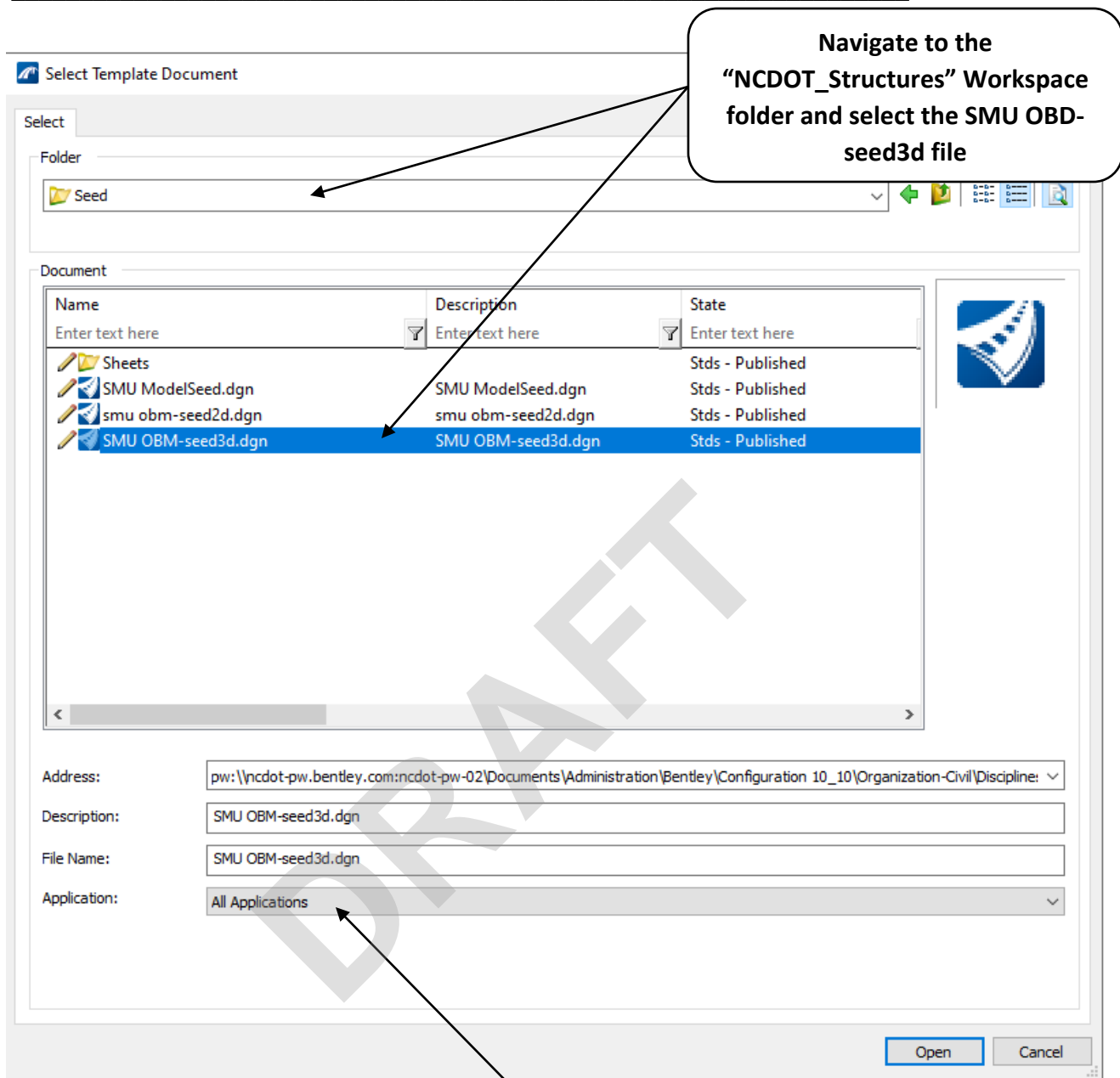

Advanced Document Creation Wizard

Define Document Code
You should define (generate) unique document code.

Document Unique Identifier

TipNumber	U-5816
Unit Name	SMU
Drawing Type	GD
Optional	01
County_Code	48
Bridge Number	B000

U-5816-SMU-GD-01-480000

Show Advanced Generate Options

< Back Next > Cancel

Fill out the metadata fields for the file being

Advanced Document Creation Wizard

Document Properties
Define required document properties - the name and the file name.
Optionally, you can also define document description and version string.

New document name
401_001_B-5121_SMU_GD01_S01-00_480123.dgn

Description for the new document
General Drawing Sheet 1

New document file name
401_001_B-5121_SMU_GD01_S01-00_480123.dgn

Version

Application:
OpenBridge Modeler CE 10.12

Save as type:
dgn

< Back Next > Cancel

Complete the file name following the guidelines in Chapter 2, note the metadata entered earlier will partially create file name.

Update the Description to match dgn

Select "OBM 2023" as the application.

Advanced Document Creation Wizard

Define Document Attributes
You should define environment specific document attributes. Modified attributes may apply to remaining documents.

SharePoint Export
SharePoint Export Date

Unit Name: SMU
Drawing Type: GD
County Code: 48
Bridge Number: 0000
Optional: 01
File Name: U-5816-SMU-GD-01-480000

Submitted By:
Submitted By Email:
Structures Task(*): Drafting
Key Structures:
Bridge Element(*): General Drawing
Structures Submittal Phase(*): Final Plans DGN

< Back Next > Cancel

Select the metadata for the remaining fields, if one or more does not apply leave blank

Advanced Document Creation Wizard

Define Secondary Document Attributes
You should define secondary document attributes.

Tip or Non-Tip Number: 15BPR.62
Project Manager:
Division Number: 05
FA Number:
WBS Number: 15BPR.62
County: WAKE
Contract Number:
Project Location:
Type_of_work:
Length_in_Miles: 0.000
ROW_Date:
Let_Date:
Municipality:
Route:
Status: CRTD
Utility Impact:
 UpdateField
Project Name:
< Back Next > Cancel

Fill out the metadata fields that are blank that you can, otherwise leave input fields blank

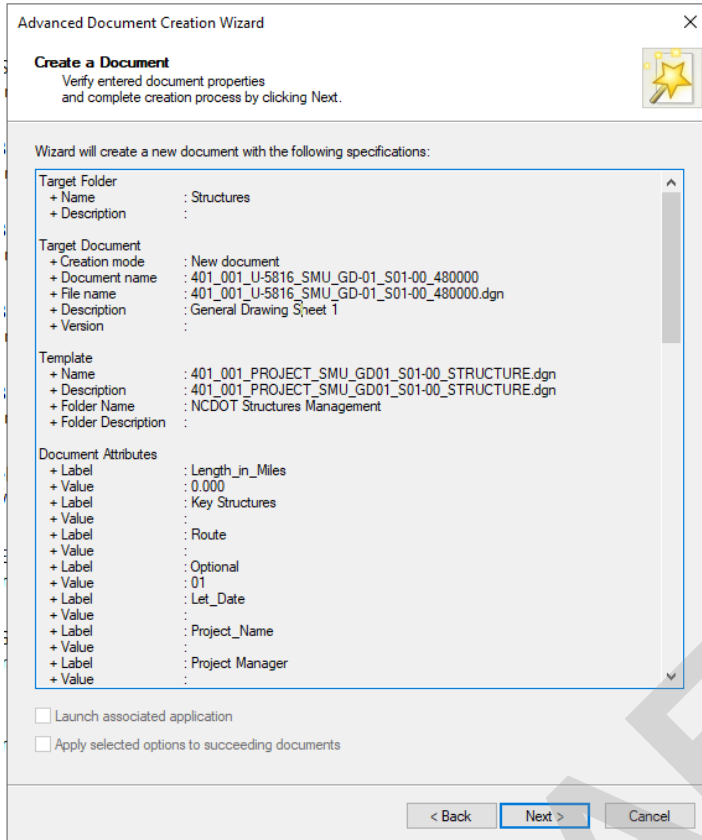

Verify metadata fields are correct, otherwise use the "Back" button to revise as needed

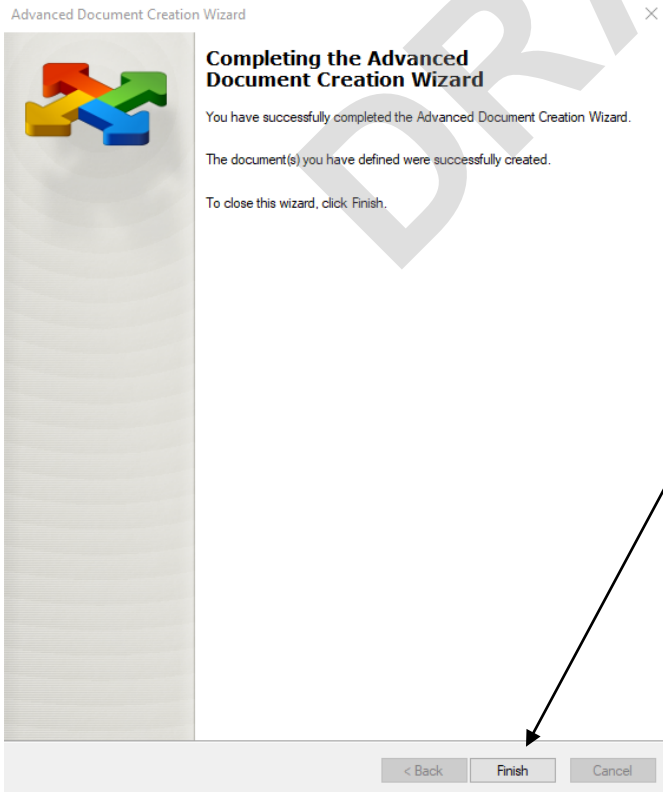

Use the "Finish" button to create the DGN

3.3 OPENING AN EXISTING DGN IN BIM WORKFLOW

3.3.1 Open OBD file Browser

Once OBD is opened you will see the following window:

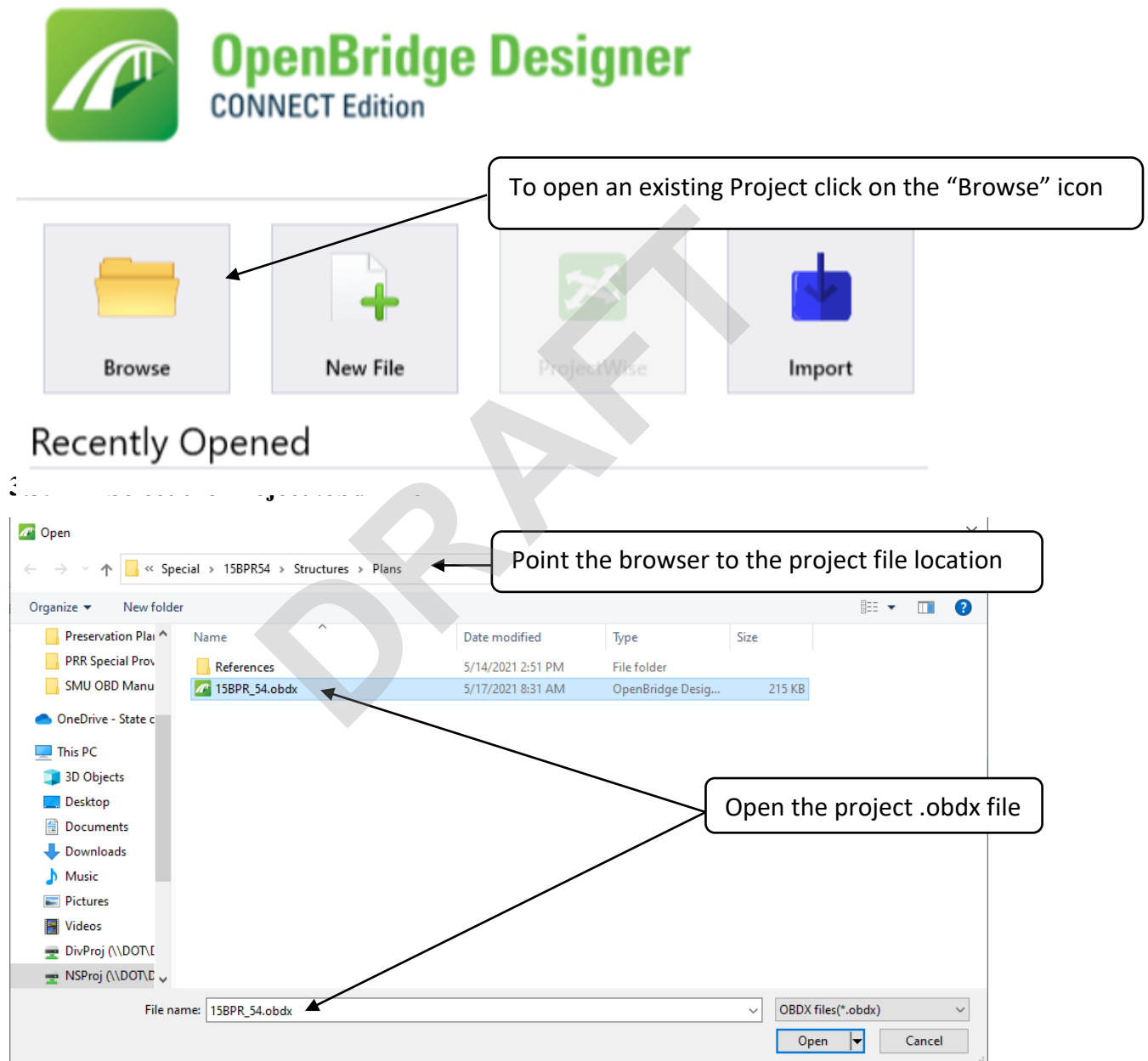

3.3.3 Select and Open Existing DGN

Browse the structures and their associated DGN files here

To open an existing DGN file, select it

Then click here to open the selected file

This preview screen allows you to zoom in and out of the dgn

OpenBridge Designer CONNECT Edition

Modeling Analysis Drawings Interop.

Modeling

OpenBridge Modeler

401_003_B5121_SMU_GD02_S002_910227.dgn

4/17/2020 8:03:03 AM 62 KB

Identify element

Warnings - Click Here

ProjectWise Status: Not Initialized

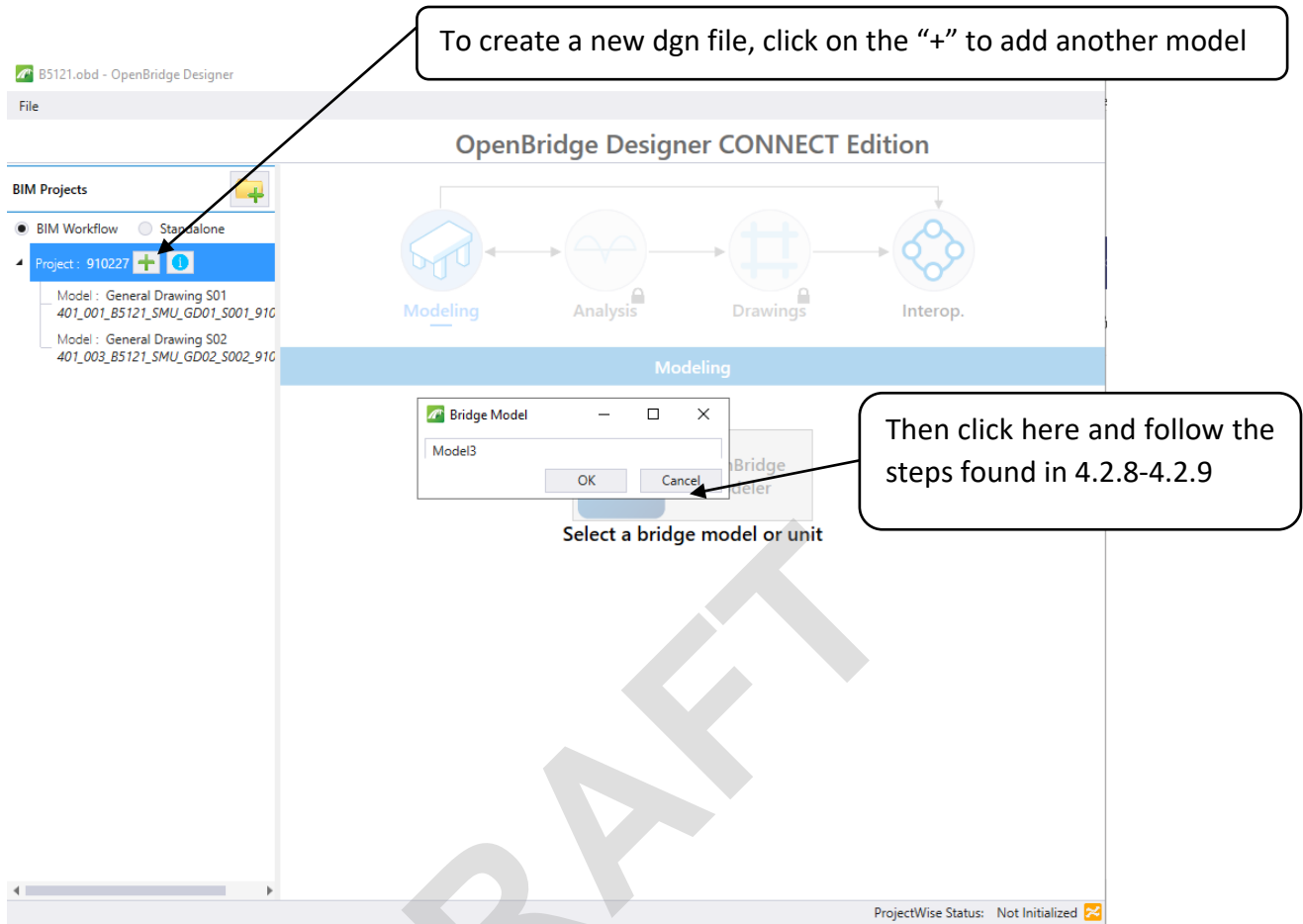

To attach the dgn created to the new bridge model, see 4.3.

3.5 OPENING LEAP DESIGN SOFTWARE

Follow the steps outlined in 4.2.8-4.2.9, then

The screenshot shows the OpenBridge Designer CONNECT Edition interface. On the left, the 'Standalone File Groups' panel is open, showing a 'Standalone Group : 910227'. A callout box labeled '1st Select a "Standalone" workflow' points to this panel. In the center, a workflow diagram shows 'Modeling', 'Analysis', 'Drawings', and 'Interop.' tabs. A callout box labeled '4th Select the "Analysis" tab' points to the 'Analysis' tab, which is currently selected. Above the workflow diagram, a 'Standalone Name' dialog box is open with '910227' entered. A callout box labeled '3rd Use the structure number as the Standalone Name and click "OK"' points to this dialog. Below the workflow diagram, three application buttons are visible: 'LEAP Bridge Steel', 'LEAP Bridge Concrete', and 'RM Bridge'. A callout box labeled '5th Select the LEAP Design application needed' points to these buttons. A 'ProjectWise Status: Not Initialized' indicator is visible at the bottom right of the interface.

Be sure to name and save Leap Design files to their appropriate project folders.

3.6 OBD DGN WORKFLOW

Once in OBD, selecting the correct workflow for the file is important.

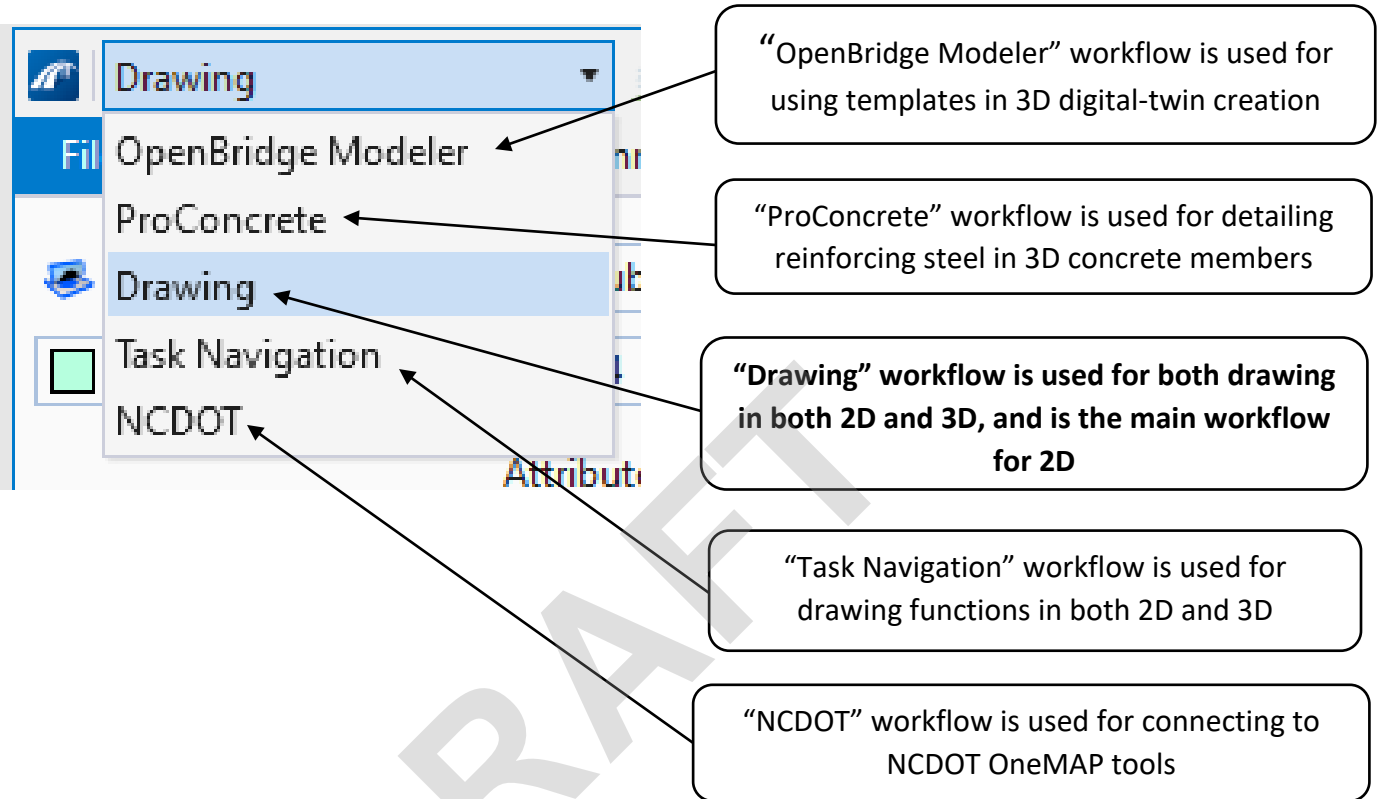

3.7 DGN MODELS

SMU utilizes the Design, Drawing and Sheet models.

To create these models SMU uses the Drawing tools, such as Place Named Boundary. Future chapters will describe how to use the Drawing tools in the plan production process.

The following sections will describe what is in each model, how to manually rename and generate the models if needed, and how to view all the models using the models dialog.

3.7.1 Models Dialog

To view models in the DGN, open the “Models” dialog box.

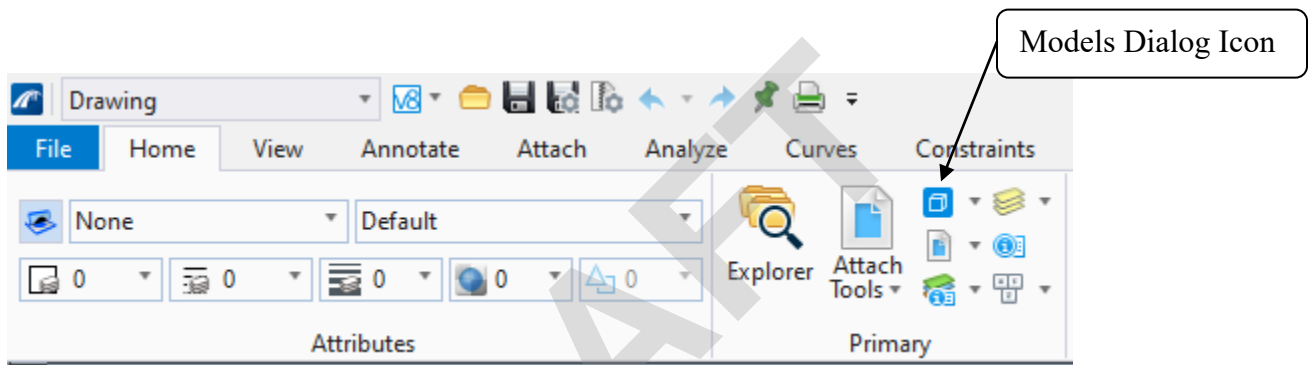

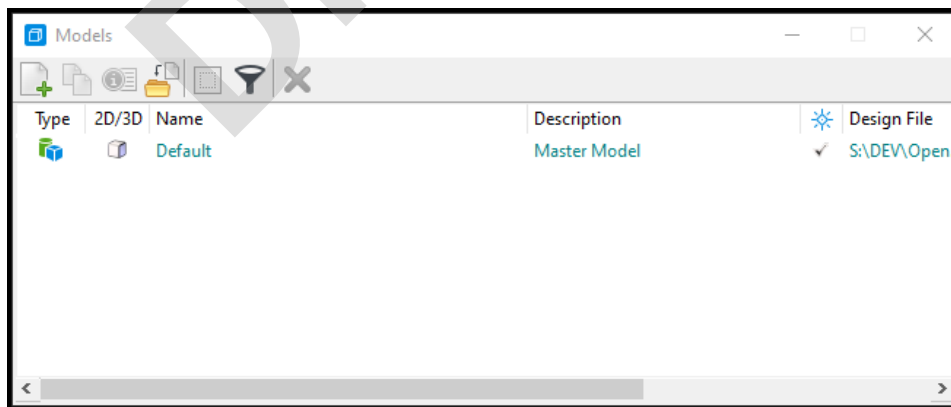

The default Models Dialog Box will look like this:



There are three different types of models that can be created within a DGN; a Design Model, a Drawing Model, and a Sheet Model.

3.7.1.1 Design Models

Design Models have default black backgrounds and can be either 2D  or 3D  . The default design model in SMU’s seed file is 3D and will remain as a 3D model, the user can close the view 2 window and save settings to remove the isometric view and make the model feel like a 2D model. A Design Model is meant to contain the following information:

- 3D digital twin that represents what is to be built or an existing structure, drawn full size (1:1) or,
- 2D elements that represent what is to be built or is existing, drawn full scale (1:1)
- Not intended for publication, only for editing
- Can be a part of a complex design, where multiple design models can be referenced to each other to form a design composition.

To rename the default Design Model:

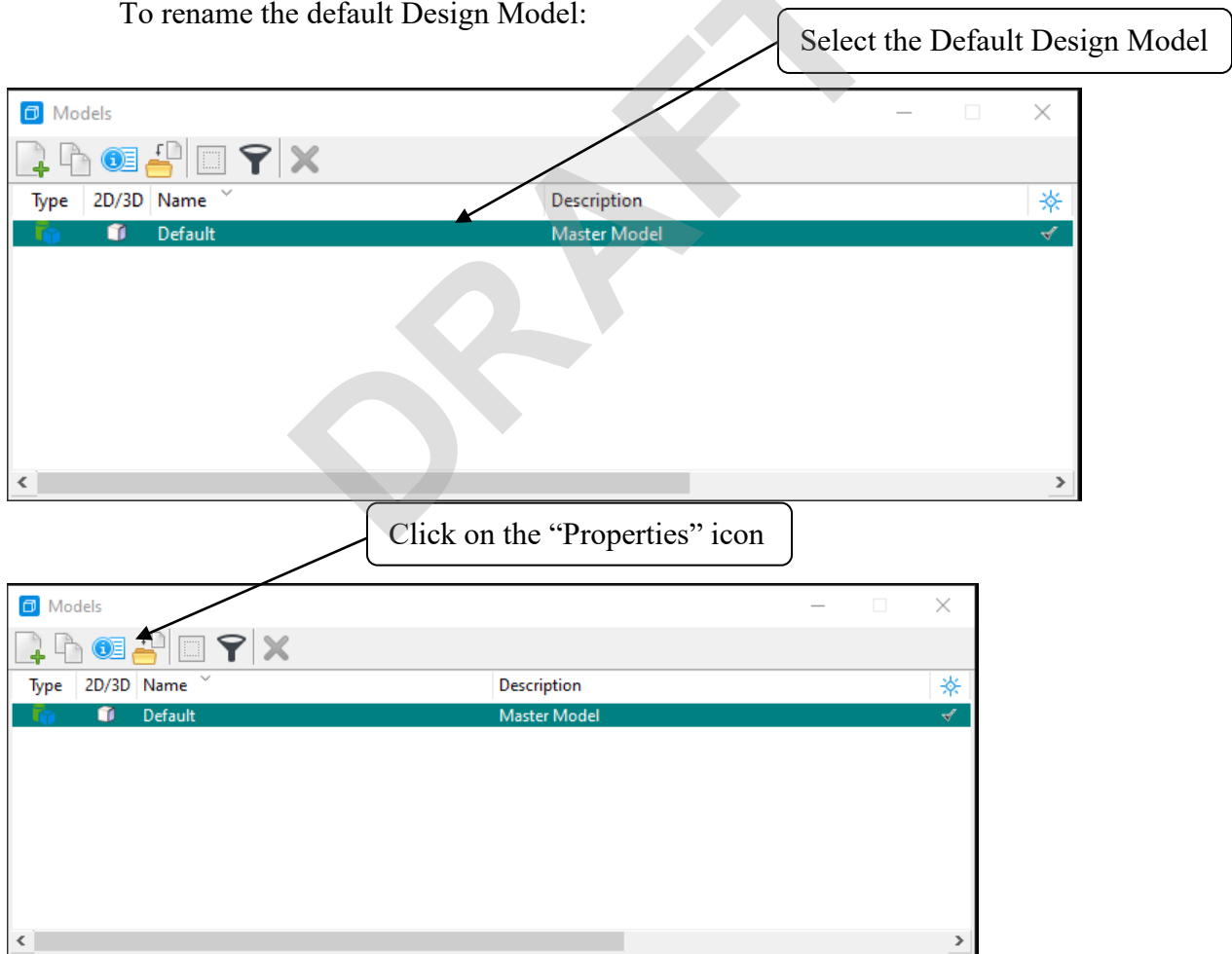

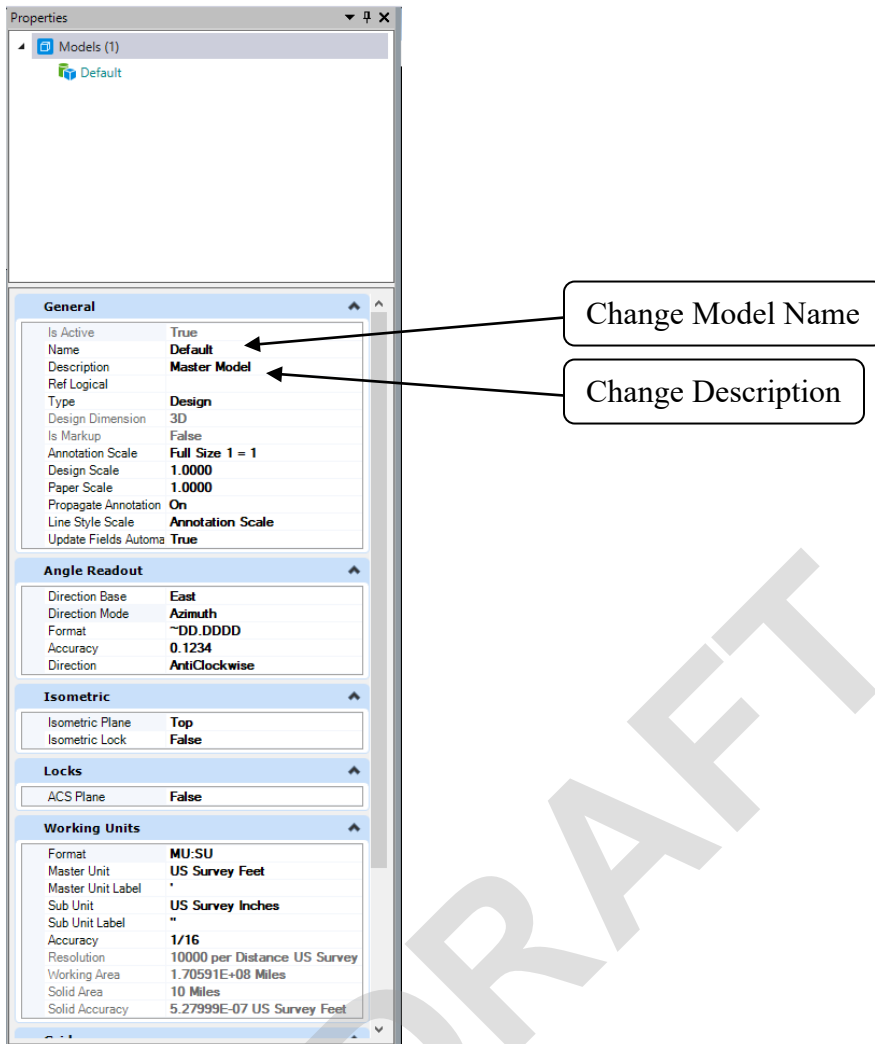

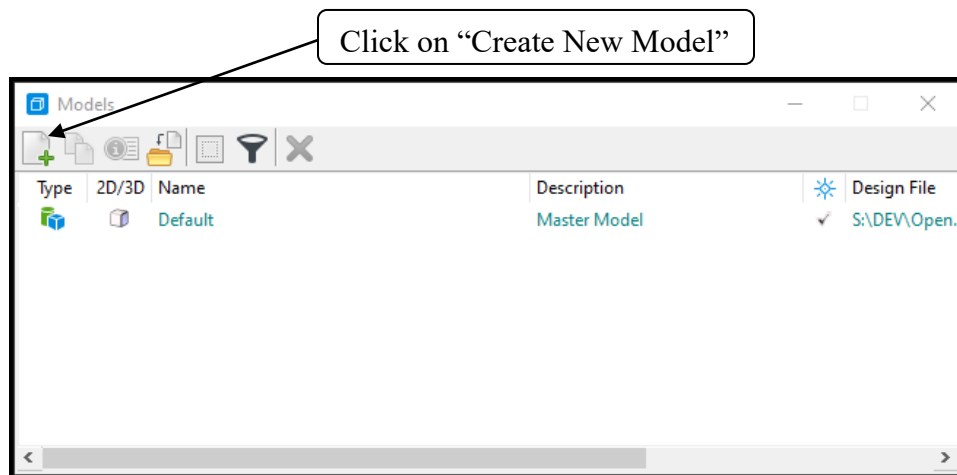

Once the Properties are updated as needed, save the file and close the Properties dialog box.

To create a new Design Model

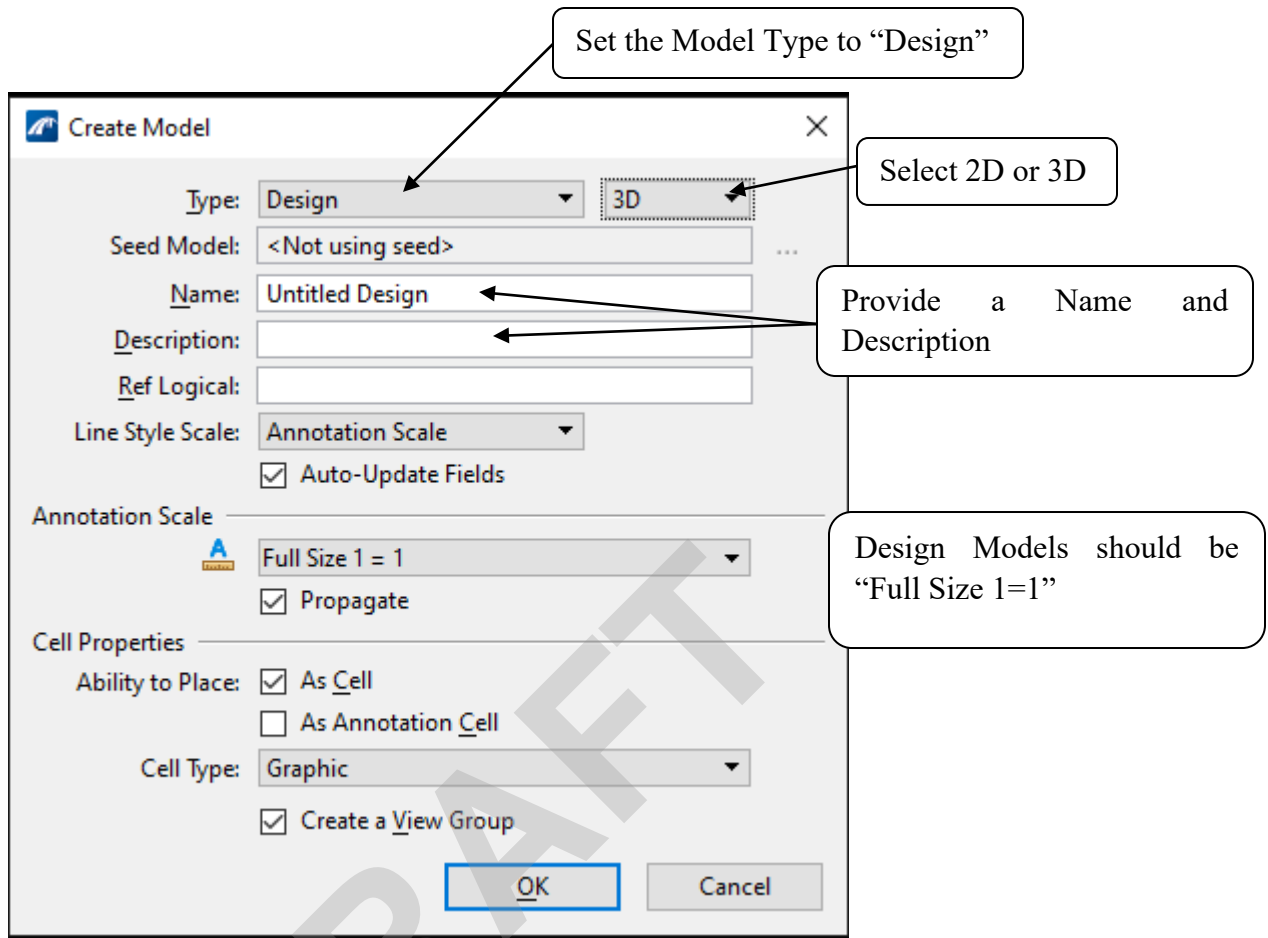



3.7.1.2 Drawing Models

Drawing Models have a default grey background and are always 2D . A Drawing Model is meant to contain the following information:

- An area for attaching Design Models 1:1 as references (typically done with the drawing tools cutting views of the 3D digital twin)
- Used as the location where non-sheet specific annotation is applied (dimensions, callouts, etc.)

To create a new Drawing Model, without using a drawing tool (such as the Place Named Boundary tool).

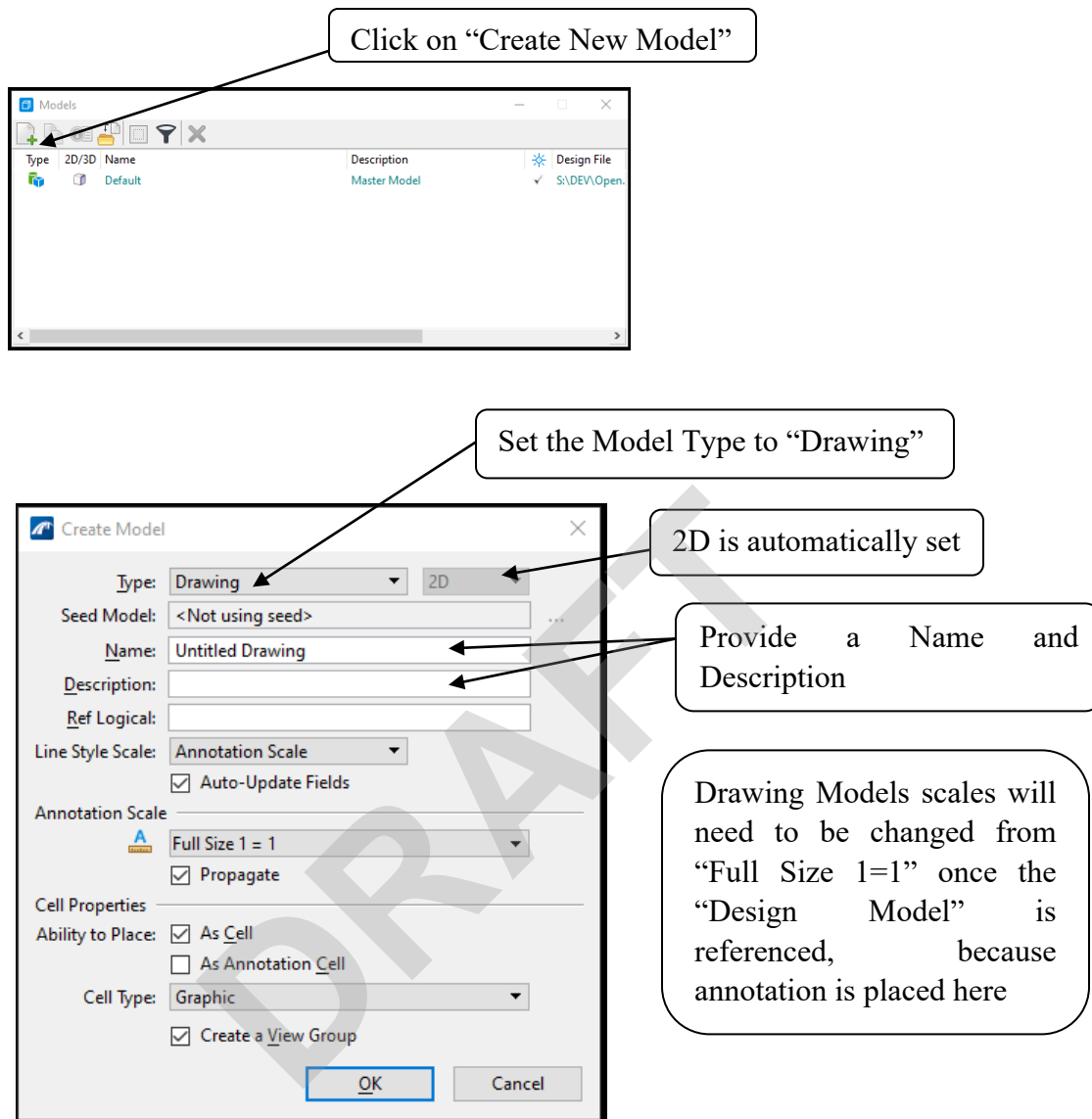

3.7.1.3 Sheet Models

Sheet Models have a default white background and are always 2D . A Sheet Model is meant to contain the following information:

- Used to define the ready for printing document
- An area where the Drawing Models are referenced and attached at their own scale to create a final plan sheet
- Has defined printing output settings (like ANSI D paper size)
- Includes a sheet boundary which defines the printing area

To create a new Sheet Model, without using a drawing tool

Click on “Create New Model”

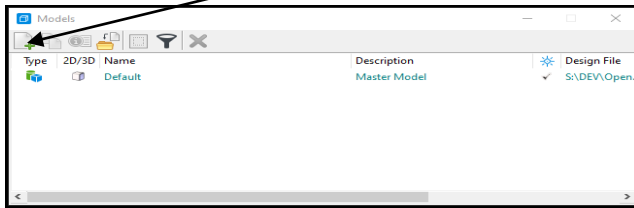

Set the Model Type to “Sheet”

2D is automatically set

Provide a Name and Description

Sheets are always “Full Size 1 = 1”

Set size to “ANSI D”

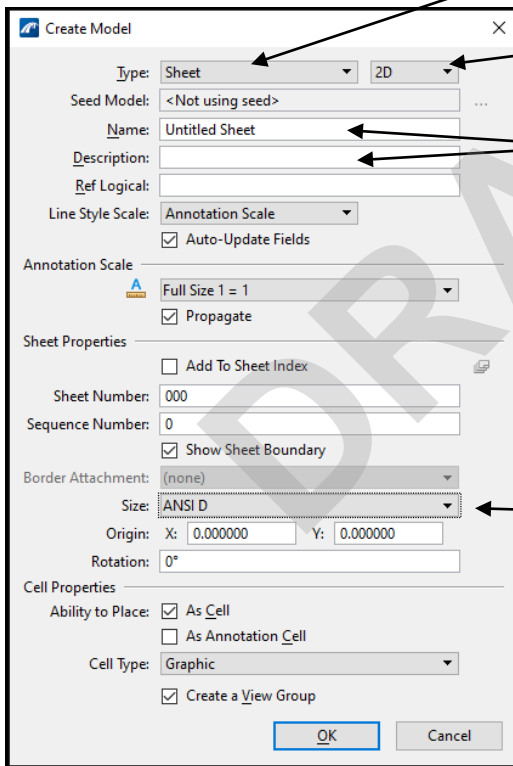

3.8 CIVIL TOOLS

The Civil tools are an application designed to provide Civil/Site functions

3.8.1 Civil Analysis Point Tool

To find stations, elevations, and offsets of locations along the -L- or other alignments, use the following tools:

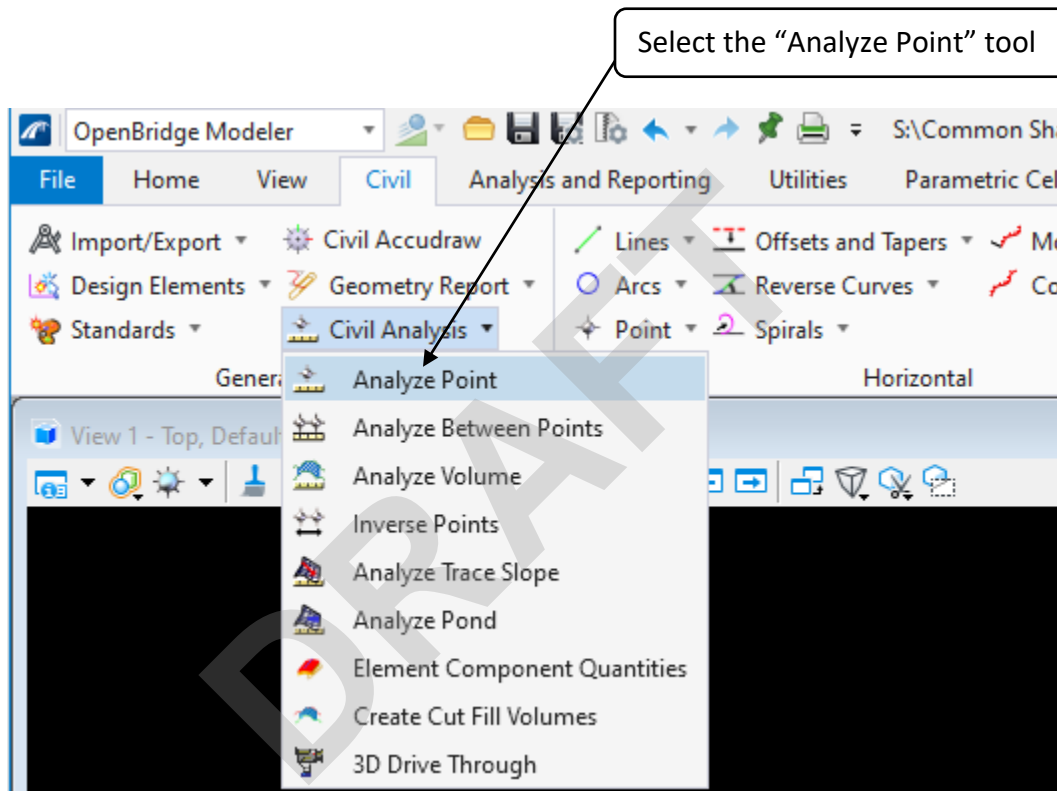

3.8.1.1 Finding Stations, Elevations and Offsets along an Alignment

To find the station, elevation and offsets of a location along an alignment, after selecting the Analyze Point tool, Click on the alignment to which you want to find the station, elevation and/or offset from, then click on the point which you want the info for and the information will be displayed in a box beside the cursor.

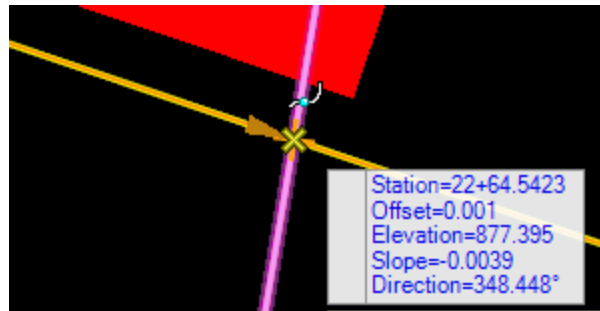

3.8.1.2 Finding Elevations along the Terrain

To find an elevation on the terrain, select the Analyze Point tool. Select a leg of the terrain triangle nearest to your point of interest and then click on the point of interest to get the exact elevation at that point.

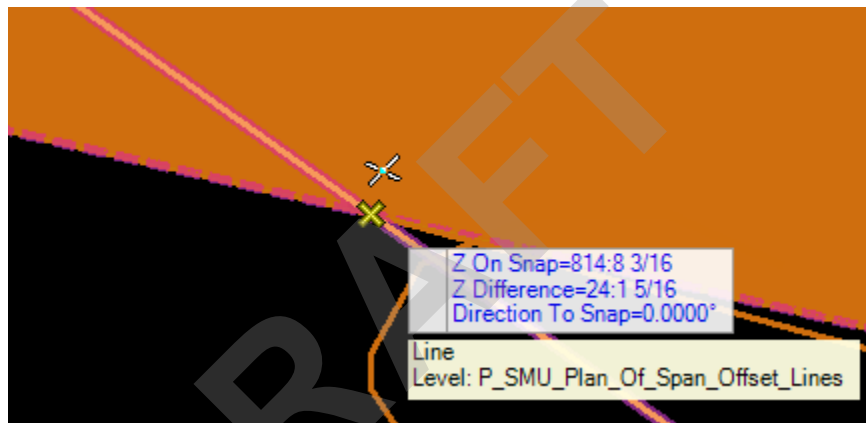

The elevation will appear in a display window beside the cursor as you move along the leg of the triangle, but will also be displayed in the Analyze Point toolbox window when the point is selected.

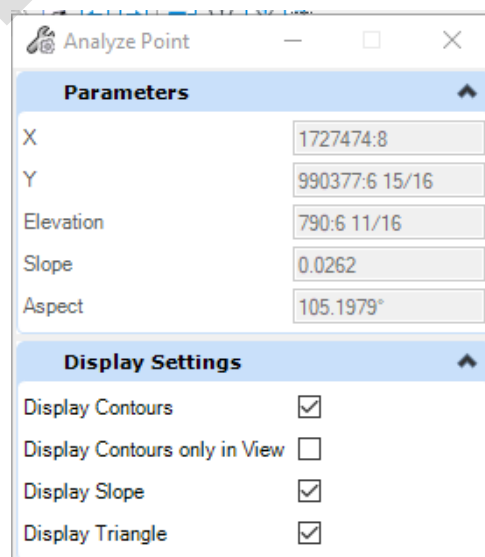

3.8.2 Horizontal Geometry Tools

3.8.2.1 Point

To place a point on an alignment similar to what was done in the past using GEOPAK, use the Horizontal Geometry Point tool.

To place a point (or work point) along an alignment, first turn on **Civil Accudraw**.

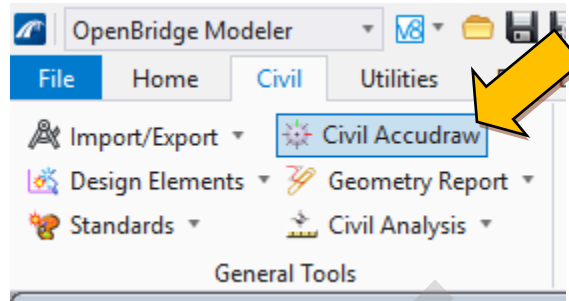

Expand the tool:

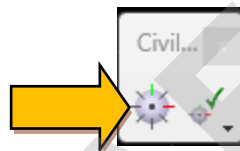

Select the “Station-Offset”



Then select the **Point** tool

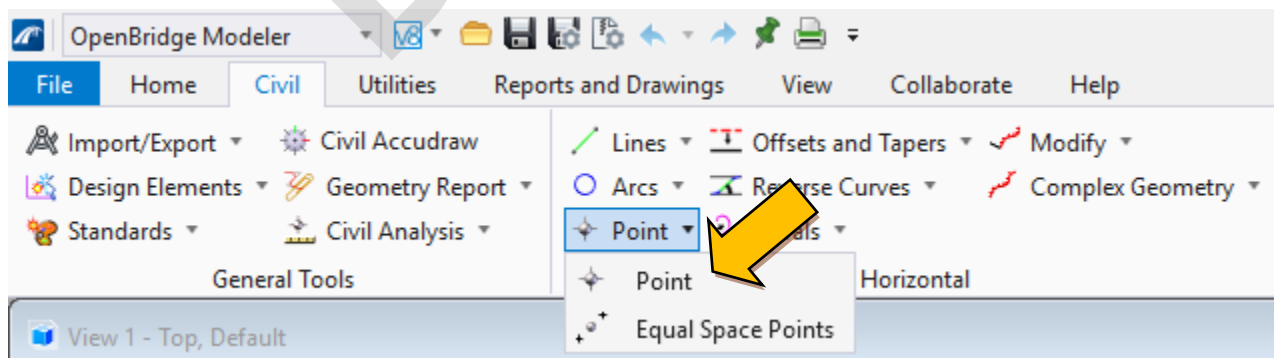

To place a workpoint, select the Workpoint feature definition:

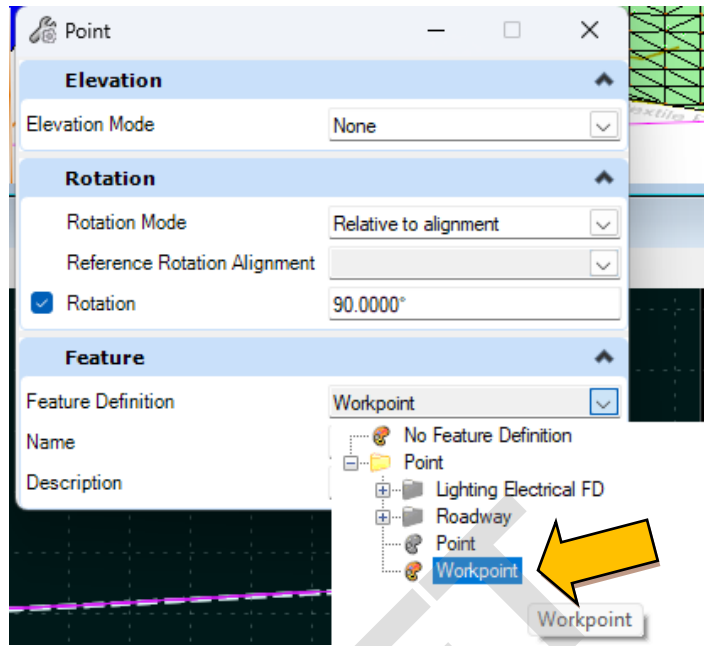

Set the workpoint name:

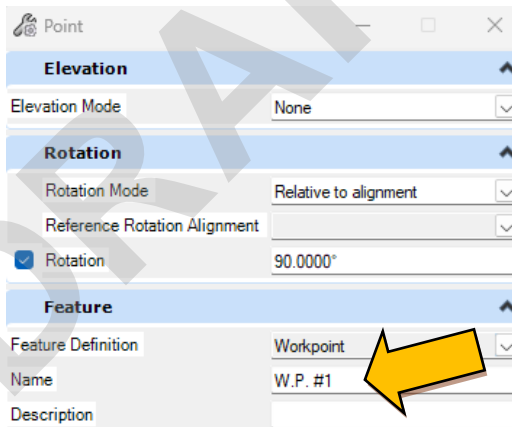

Select the alignment:

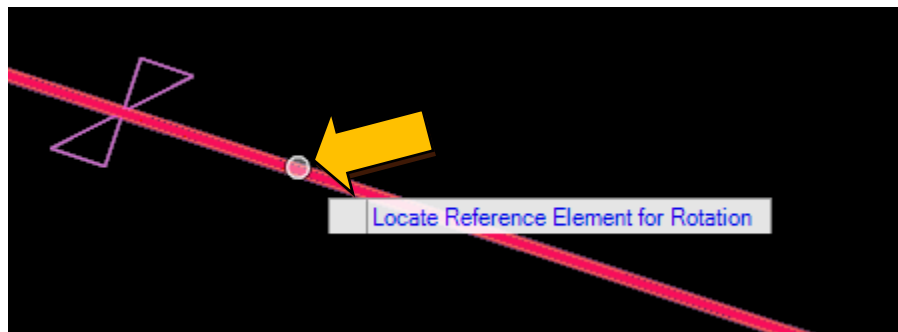

Then press the letter “O” on your keyboard

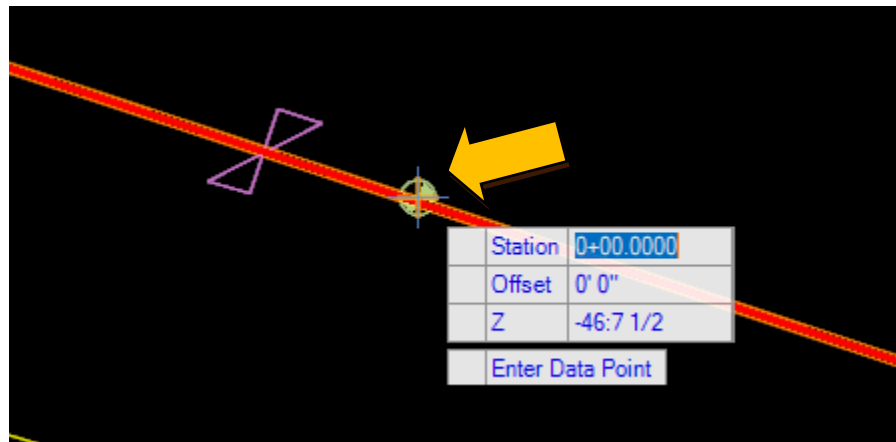

The Workpoint symbol will appear, as well as the Station and offset input box.

Enter the Station for the placement of the workpoint and use the tab button to move to the Offset and Z cells.

3.8.2.2 Offsetting Roadway Alignments

To offset a Roadway alignment to establish horizontal clearances and offsets requires using the Offsets and Tapers tools. Copying Roadway alignments without using these tools can cause an OpenBridge file to become “read only” due to the civil data linked with the alignment.

Use the “Offsets and Tapers, Single Offset Entire Element” tool.

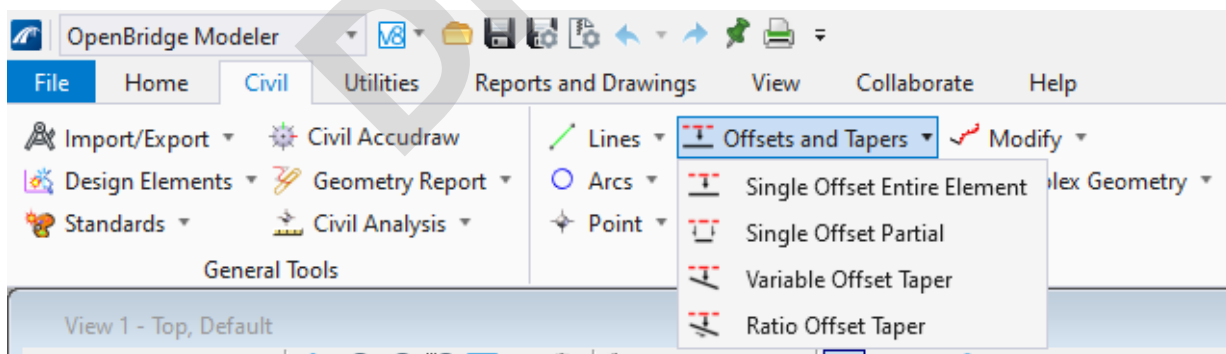

Once a tool is selected, provide the desired offset and any other necessary information.

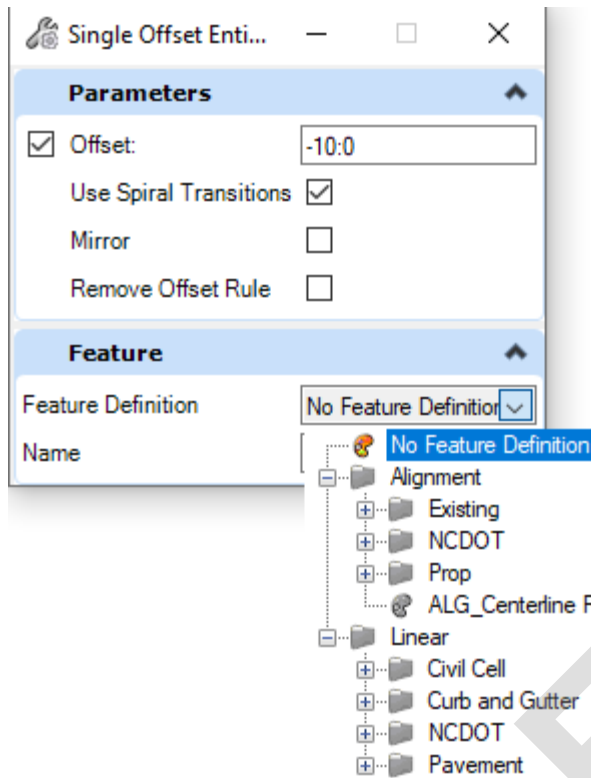

Select the alignment to offset and click again to set the offset line.

3.8.2.3 Creating an Horizontal Alignment

In the default model, attach the ECTM and FS files in Coincident-World orientation.

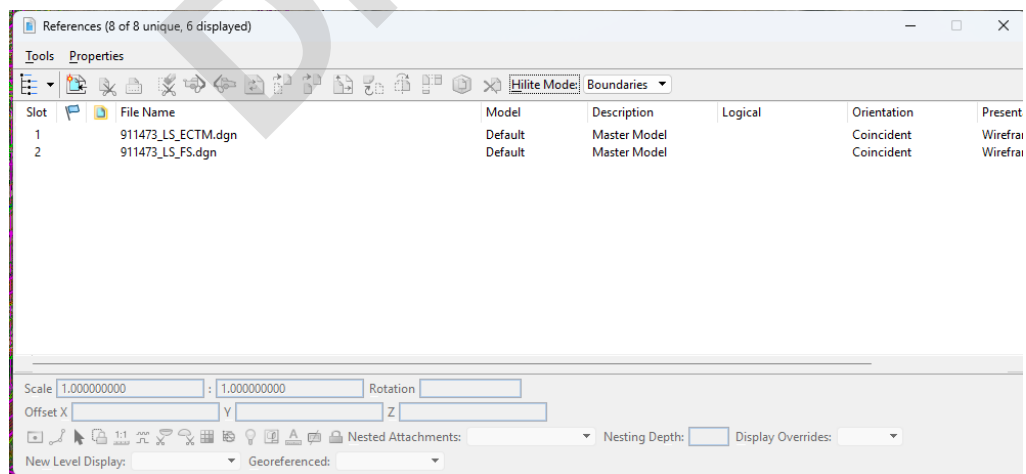

After the reference files are attached, fit the views to the structure location.

Hover over the existing alignment created by L&S in the View 1 (plan view) to determine if there is an active profile line. In the image below, there is no active profile established for the existing alignment.

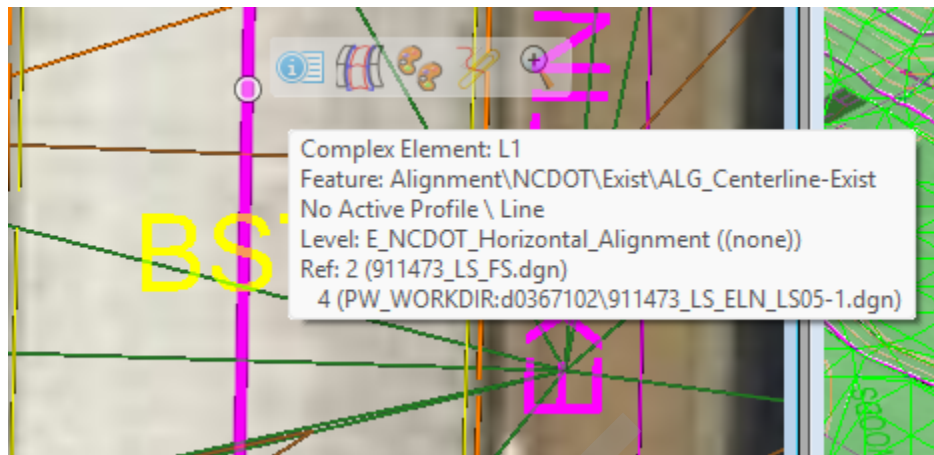

To create an alignment, go to the “Civil” tab, and in the “Horizontal” tools use the “Offsets and Tapers” tool, “Single Offset Entire Element”

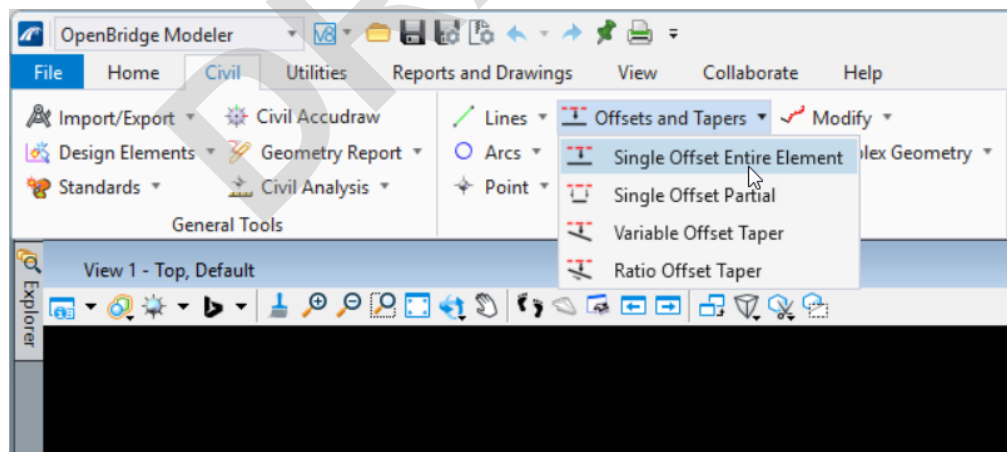

Before you click on the surveyed centerline of structure, set the offset to 0:0 (no offset from the alignment element L&S created from surveying the center of existing roadway.)

Set the Feature Definition to “Existing ALG Centerline” and Name the Line to match L&S’s name, then select the line in the plan View 1 window

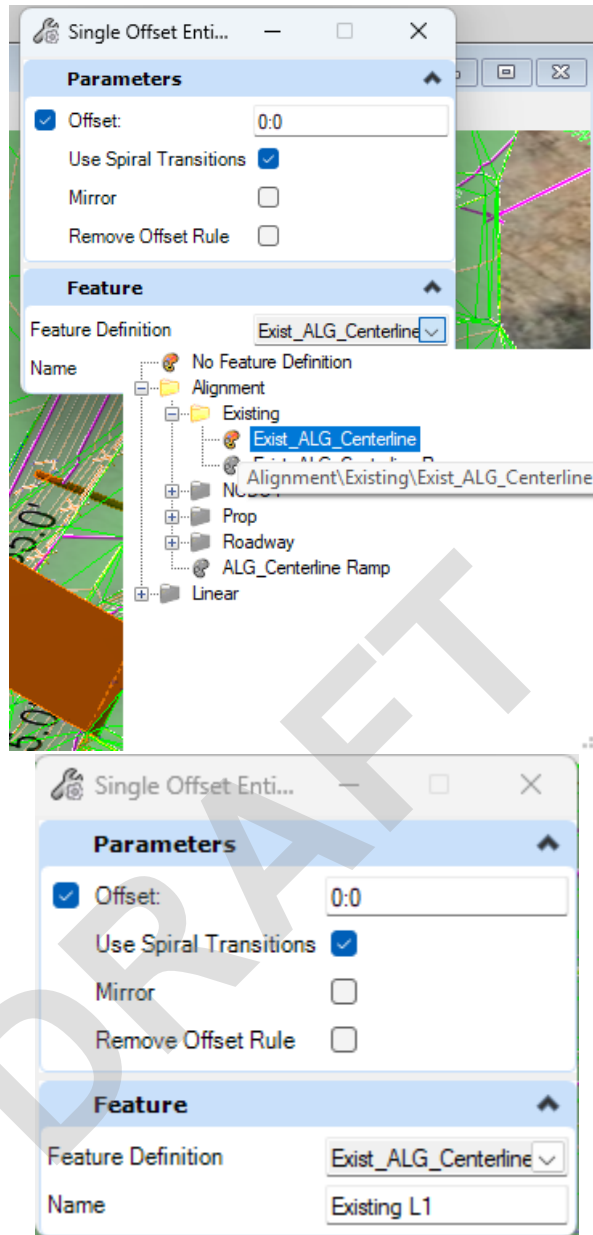

In View 1 (plan view), click on the L&S alignment to select it, and to set it.

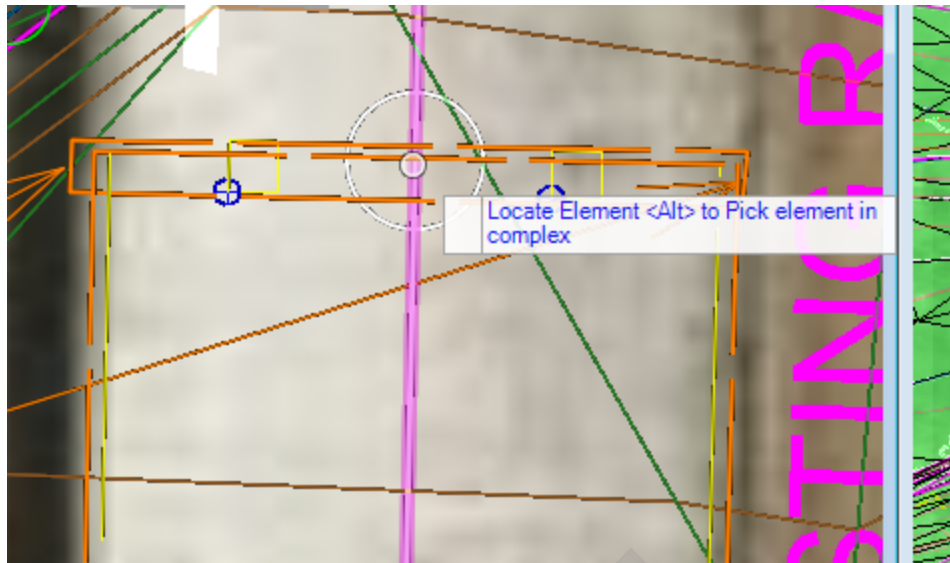

To set the stations, use the Horizontal “Modify Start Station” tool.

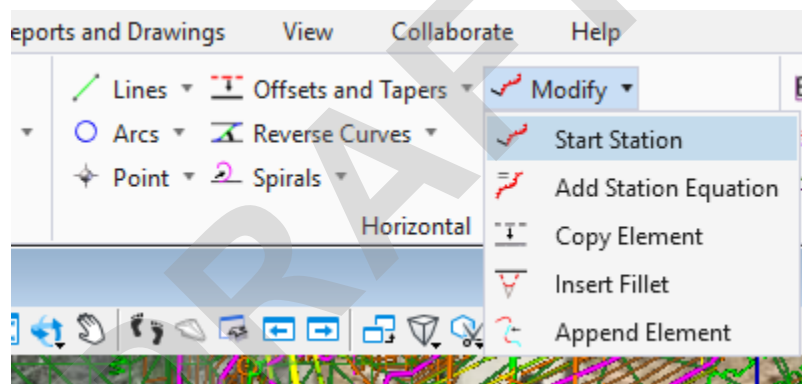

Enter the starting station desired (typically 10+00.00) into the Parameters box.

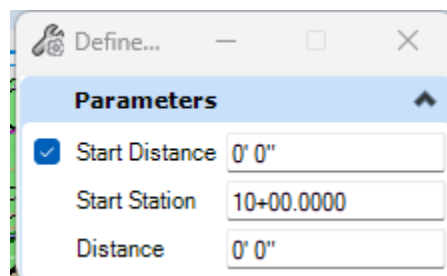

Then select the alignment in the plan view and follow the prompts, click to accept.

3.8.3 Vertical Geometry Tools

3.8.3.1 Adding Vertical Geometry to an Alignment

After a horizontal alignment is created, hover over the centerline survey over the structure, right click and hold, go to “View Control”, “3 Views Plan/Profile/3D

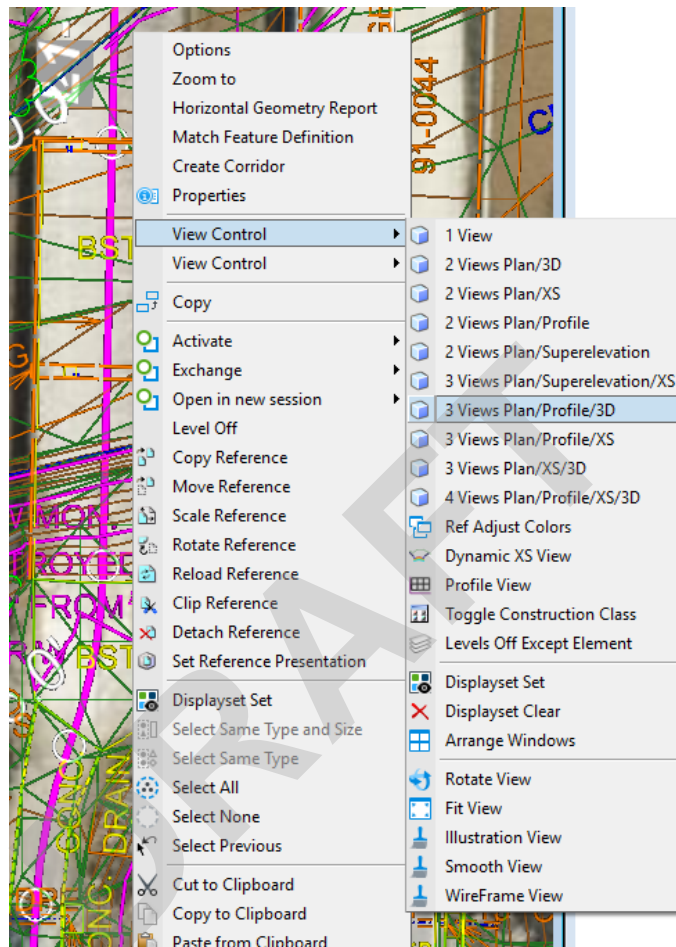

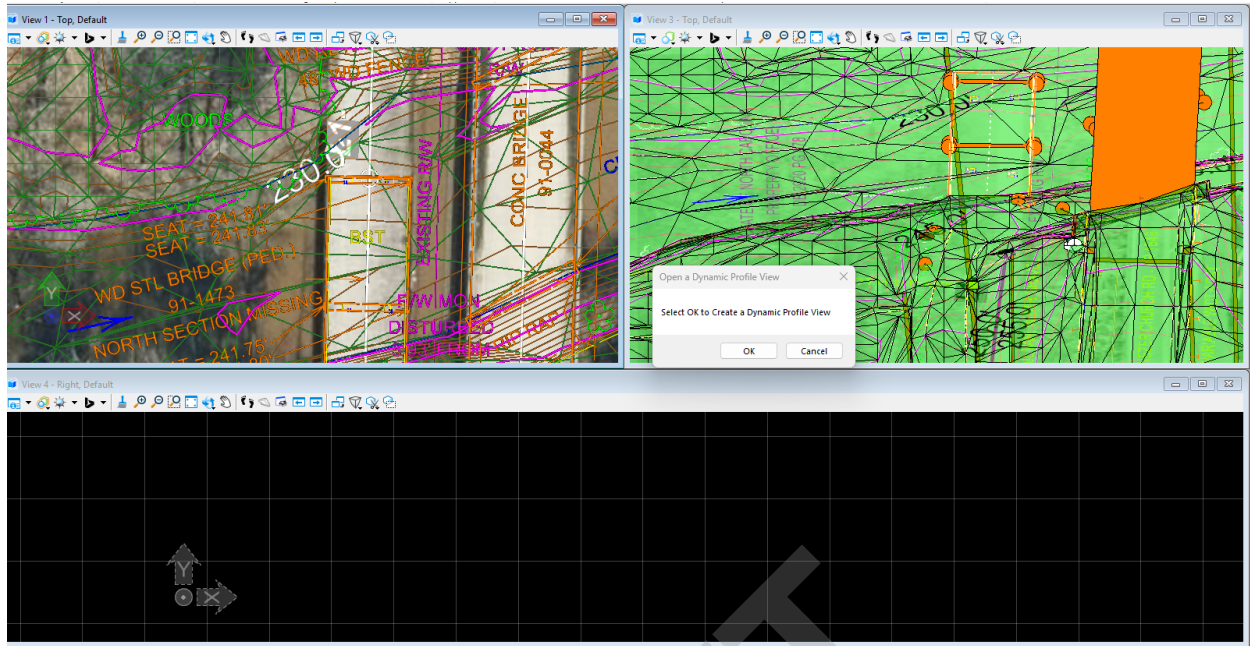

Select “OK”

In View 1, click on the created alignment and then move your cursor to View 4 and click.

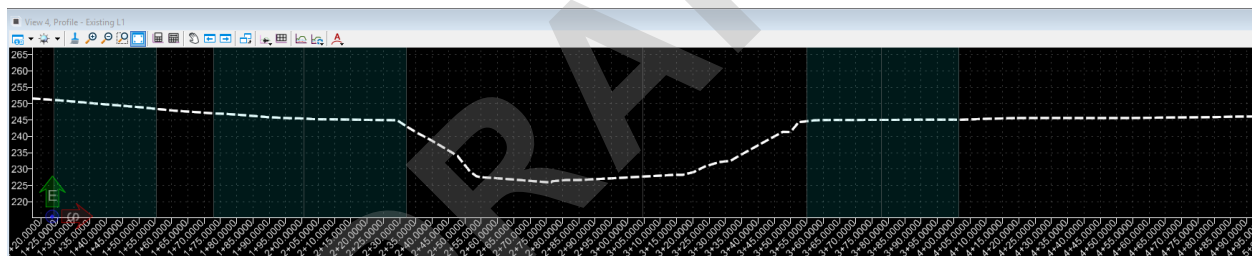

The profile along the alignment should appear in the View 4 window.

If it does not appear, zoom out in View 1 and activate the terrain file by finding the survey boundary line (the outline of the survey) and hovering over it until the property’s icon toolbox pops up. Select the second icon “Set Active Terrain Model”.

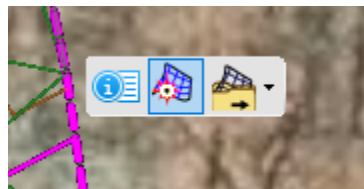

Go back to View 4 and click the “Fit View” icon and the profile should appear.

To add a vertical alignment, use the “Complex Geometry by PI” tool

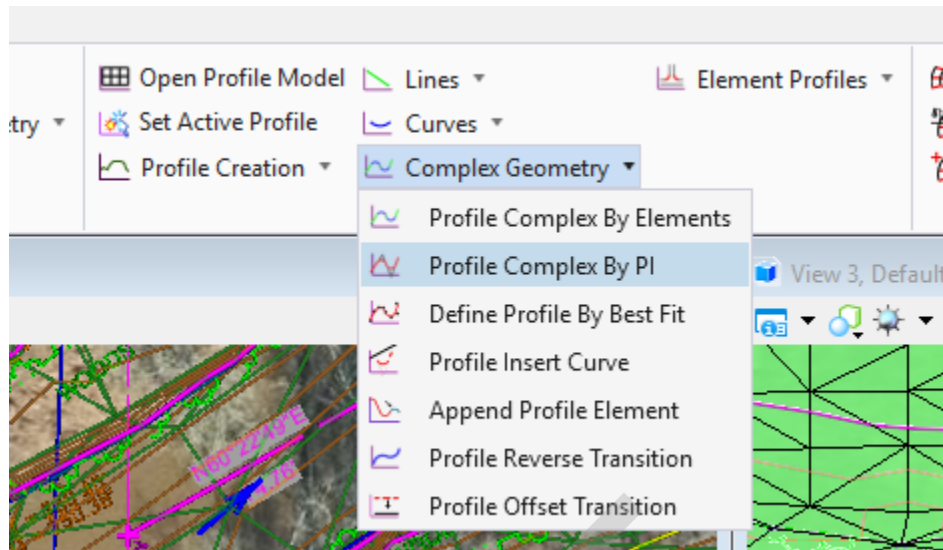

Set the Feature Definition and Name to match what was used in the Horizontal Offset and Tapers tool.

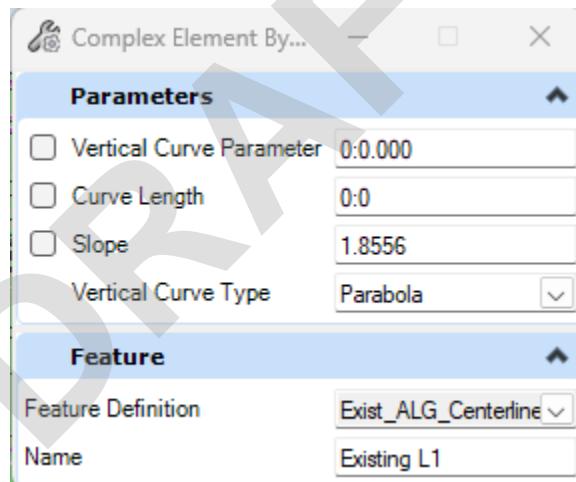

Then, use the tool in View 4 to click on points along the profile and create a vertical alignment.



Now, set the newly created alignment as “Active” by selecting it and move off and back on the line until the tool bar pops up. Once the tool bar appears, select the second icon “Set As Active Profile”.

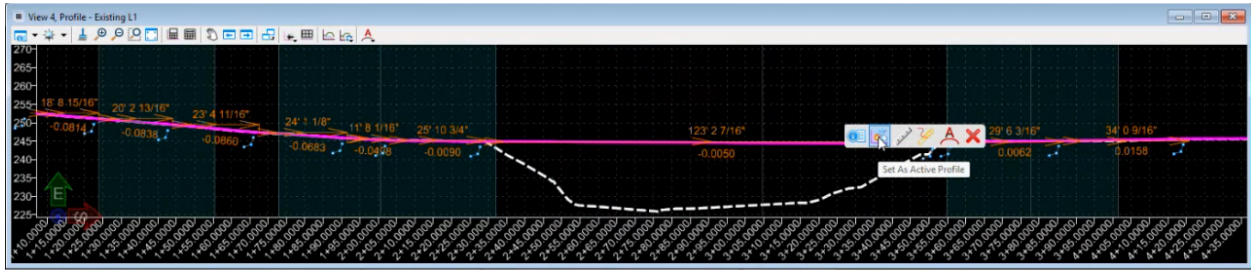

DRAFT

3.9 PLACE NAMED BOUNDARY TOOL

The Place Named Boundary tool can be used in both 2D and 3D plan production for creating views used in plans.

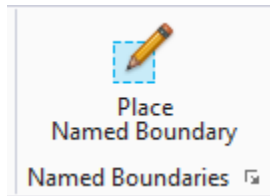

Place Named Boundary tool options from left to right:



- **Civil Plan:** 3D modeling tool allows the user to select a horizontal alignment with which to associate the named boundary for a plan view by defining the boundary scale, length, left and right offsets.
- **Civil Plan by Element:** 3D modeling tool allows the user to select a horizontal alignment with which to associate the named boundary, along with an existing element as a boundary for a plan view.
- **Civil Profile:** 3D modeling tool allows the user to select an alignment's vertical profile with which to associate the named boundary by selecting the boundary limits from an existing civil plan boundary or by station definitions.
- **Civil Cross Section:** 3D modeling tool allows the user to select the horizontal alignment with which to associate the named boundary by defining left and right offsets and the intervals at which to create the cross sections. (*not preferred for creating bridge typical sections*)
- **Civil Cross Section by 2 Points:** 3D modeling tool allows the user to select the horizontal alignment with which to associate the named boundary by clicking a point either side of the selected alignment to form a line crossing the alignment which creates a cross section at that location.
- **From Drawing Boundary:** 2D drawing tool allows the user to select one of the predefined drawing scales and fit the boundary view box around an area to create a plan view.
- **By Element:** 2D drawing tool allows the user to select an existing element as a boundary.
- **By 2 Points:** 2D drawing tool allows the user to select two points that define a rectangular boundary. *This is the most preferred method for 2D workflow.*
- **By Polygon:** 2D drawing tool allows the user to click several points to create a non-uniform multi-sided closed shape (must contain at least 3 sides) as a boundary.
- **By Length:** 2D drawing tool allows the user to select a path element along which to place a boundary by then defining the left and right offsets and boundary length.

3.10 SPACEBAR

A quick way to get to commonly used tools is to click on the spacebar, the following popup will appear near where your cursor is at for your selection.

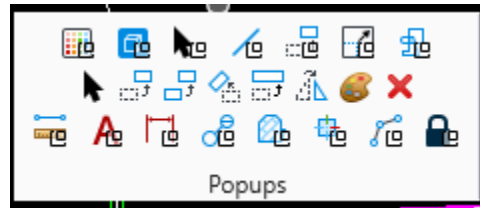

3.11 BACKGROUND MAP

To place a street or aerial map in your drawing background, take the following steps:

1st In the window View, click on “Select Background Map”

2nd Drop down to “Map Type” and select the map style desired.

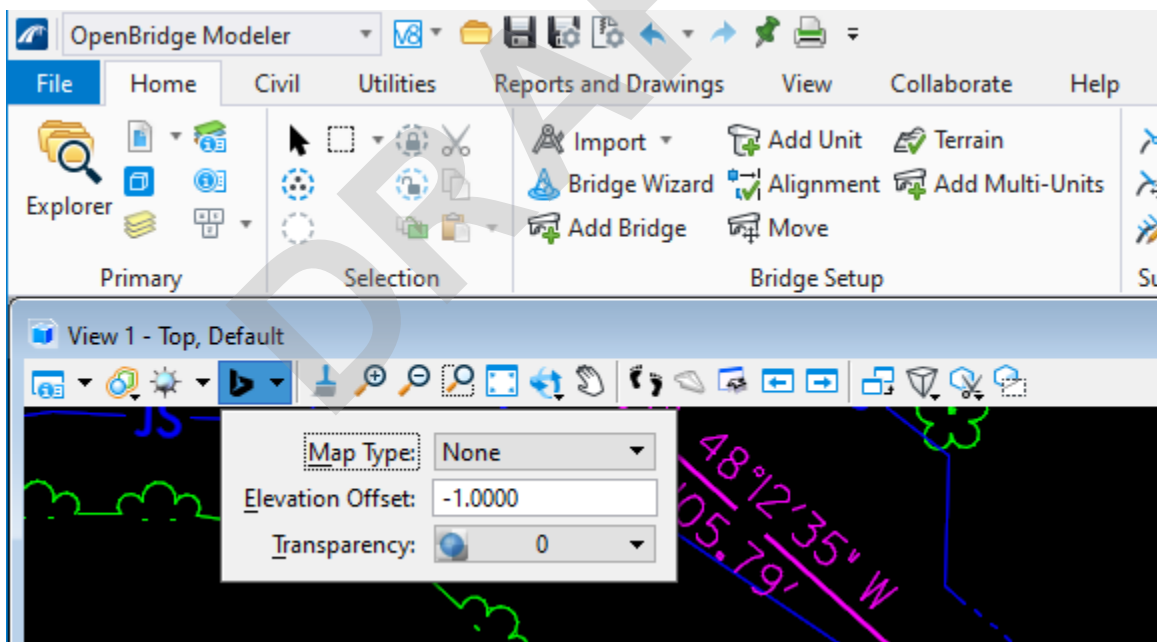

3.12 CUSTOM LINE STYLES

To use the NCDOT custom line styles for both 2D and 3D, follow these steps:

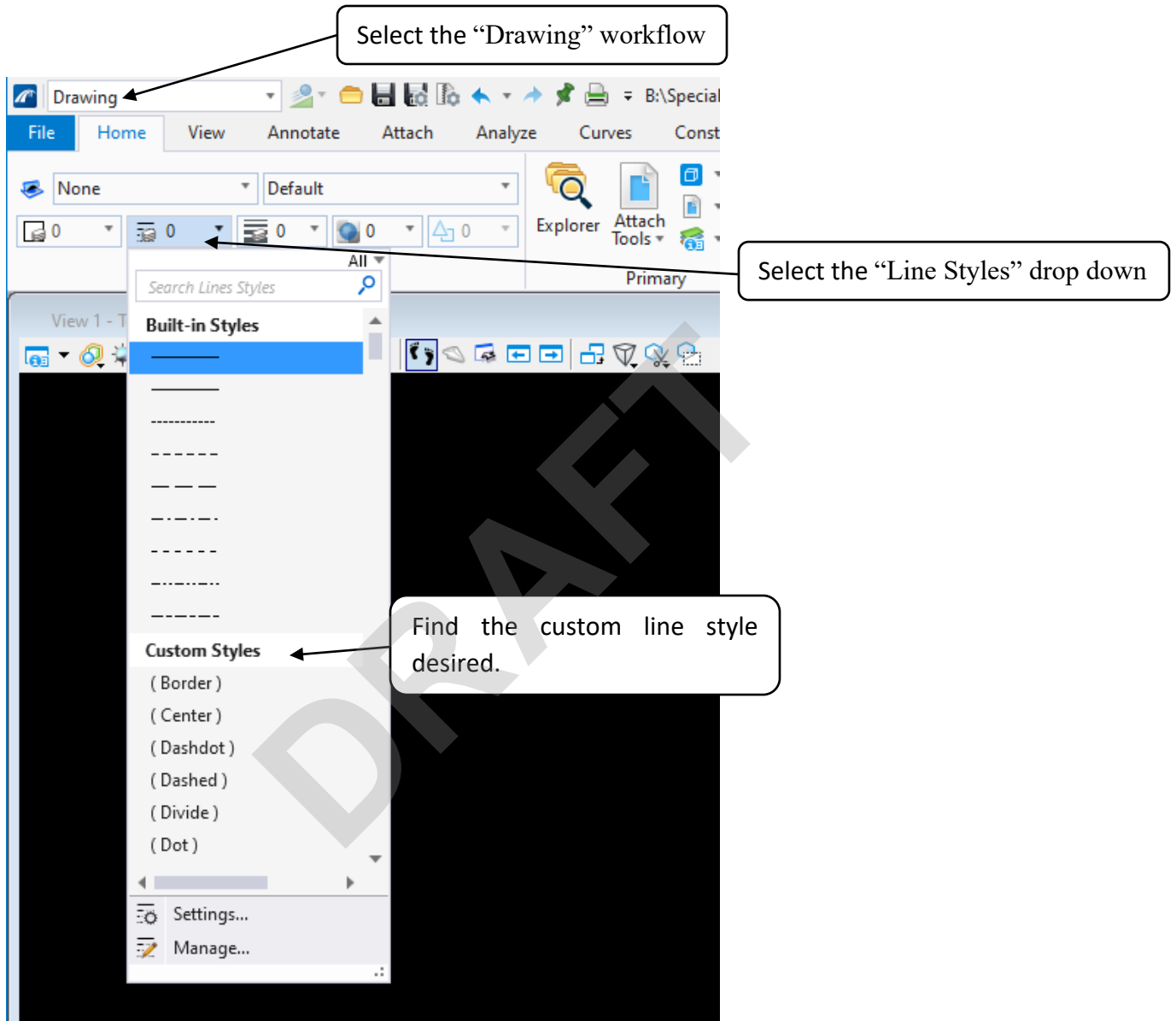

3.13 SKEWS

Refer to Section 4.1.2.2 of the *Structures Management Unit Design Manual* for information on how to show the skew angle on plans.

The following detail shows how Bentley calculates skew angles for OpenBridge Designer tools and LEAP Concrete software, note the difference.

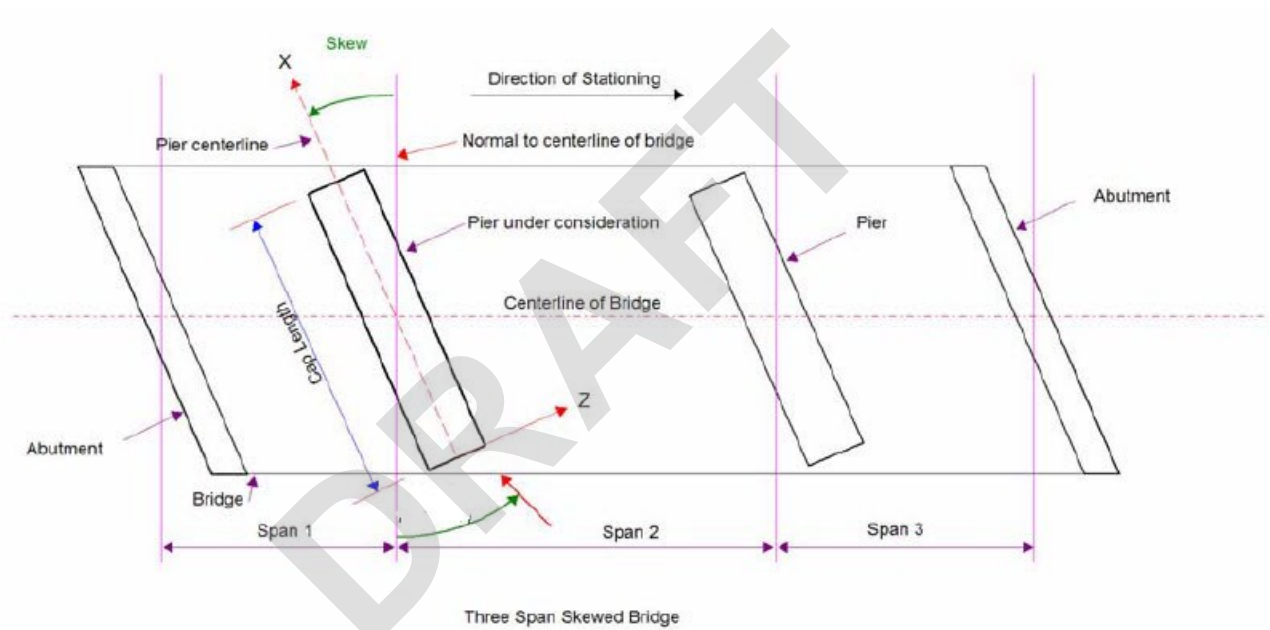

3.14 DRAWING SCALES

SMU drawing scales and ratios

Drawing Scales			
English Scales		Engineering Scales	
Full Size 1=1	1:1	1" = 5'	60:1
6" = 1'-0"	2:1	1" = 10'	120:1
3" = 1'-0"	4:1	1" = 15'	180:1
2" = 1'-0"	6:1	1" = 20'	240:1
1 1/2" = 1'-0"	8:1	1" = 30'	360:1
1" = 1'-0"	12:1	1" = 40'	480:1
7/8" = 1'-0"	13.7:1	1" = 50'	600:1
3/4" = 1'-0"	16:1	1" = 60'	720:1
5/8" = 1'-0"	19.2:1	1" = 100'	1200:1
1/2" = 1'-0"	24:1	1" = 200'	2400:1
7/16" = 1'-0"	27.4:1	1" = 300'	3600:1
3/8" = 1'-0"	32:1	1" = 400'	4800:1
5/16" = 1'-0"	38.4:1	1" = 500'	6000:1
1/4" = 1'-0"	48:1	1" = 600'	7200:1
3/16" = 1'-0"	64:1	1" = 1000'	12000:1
1/8" = 1'-0"	96:1	-	-
1/16" = 1'-0"	192:1	-	-
1/32" = 1'-0"	384:1	-	-

CONTENTS

Chapter 4.....4-1

4.1 Drafting/Model Requirements4-1

 4.1.1 2D Drawings.....4-1

 4.1.2 3D Models4-1

4.2 Detailing Requirements4-1

 4.2.1 Drafting Scales.....4-2

 4.2.2 Line Styles and Line Weights.....4-2

 4.2.3 Dimensions4-2

 4.2.3.1 PlacingDimensionsand Notations.....4-2

 4.2.4 Text Properties.....4-5

 4.2.4.1 Title Block4-6

 4.2.4.2 Professional Engineer Seals.....4-7

 4.2.4.3 Names on Plan Sheets.....4-7

 4.2.4.4 Federal Aid Numbers.....4-8

 4.2.4.5 Notes and Legends.....4-8

 4.2.4.6 Details, Sections and Views4-8

 4.2.5 Detailing Reinforcing Steel4-8

 4.2.5.1 Bar labels4-9

 4.2.5.2 Bill of Materials.....4-11

 4.2.6 Cell Libraries and Steel Shapes4-11

 Cell Libraries4-11

 Steel Shapes4-13

 4.2.7 Plan Revisions4-15

4.3 Drawing Workflow4-15

4.4 Default (Design) Model.....4-16

4.5 Drawing Model.....4-17

 4.5.1 Drawing Scale.....4-17

4.6 Sheet Model.....4-18

 4.6.1 Individual Plan Sheet Borders4-18

 4.6.2 Referencing A Master Structure Border4-21

 4.6.2.1 Creating a Master Border DGN File.....4-21

 4.6.2.2 Referencing a Project Master Border4-24

 4.6.3 Placing Plan Notes with the SMU NOTES App4-26

4.7 PRINTING PDF’s4-28

 4.7.1 References.....4-28

 4.7.2 Creating a PDF Document from a Single DGN4-30

 4.7.3 Using Print Organizer for PDF Creation of Multiple DGN’s.....4-33

CHAPTER 4

DRAFTING AND PRINTING

4.1 DRAFTING/MODEL REQUIREMENTS

All elements shall be drafted/modeled full scale (1:1) in their geospatially correct location using survey and/or alignment files for both 2D and 3D DGNs to ensure plans accurately depict the intended design. Drafting and modeling full scale will avoid design errors and capture potential construction conflicts and clashes with items such as utilities, drainage, or interim phases in staged construction.

4.1.1 2D Drawings

Each plan sheet in a plan set shall be its own DGN file. 2D drawing DGNs shall include Design, Drawing and Sheet Models. See Chapter 3 for more details on DGN models. Use of the correct element templates is critically important to ensure elements can be easily identified within the DGN.

All final plan sheets shall be in the Sheet Model.

Draft full-scale (1:1) details in the design model and scale views on sheet model as needed to provide clarity when displayed or printed on a plan sheet.

4.1.2 3D Models

Create 3D models in the Design Model (see Chapter 3 for more details on DGN models). Each structure model shall be its own DGN file.

In lieu of drafting 3D elements from scratch, whenever possible use and modify the 3D element templates available in the element? libraries. Copy and save the element templates to the project's *Bridge Templates* folder prior to modifying.

In order to share information in the 3D model with Construction and Asset Management, Item Types shall be attached to each element on the structure.

2D drawings may be created from the 3D model by referencing the 3D model into the appropriately named Design Model DGN file. Use the Drawing Creation tools (e.g. Place Name Boundary, and Typical Section) to generate views (section, plan, elevation, etc.) of the selected element in both the drawing and sheet models and to create the final plan sheet.

4.2 DETAILING REQUIREMENTS

Before starting to draft plans, determine which details are necessary to efficiently construct the bridge and manage the asset during its lifecycle. Present these details in a logically grouped order in the contract plans. Avoid scattering details throughout the plans and overcrowding a sheet with details and notes. Use standard line styles, line weights,

lettering, reference notes, etc., to produce plans that are consistent from project to project. Arrange drawings and details by determining what information needs to be placed on each plan sheet, the scales of the details shown, the number of sheets and sequence of sheets based on information found in Chapters 1, 4 and 5 of the *Structures Management Unit Design Manual*.

4.2.1 Drafting Scales

Refer to Chapters 1, 4 and 5 of the *Structures Management Unit Design Manual* for information on drafting scales.

4.2.2 Line Styles and Line Weights

Element Templates will set the line level, style, weights and feature definitions. Select and use the appropriate Element Template for the structure element being drafted.

When the correct Element Templates are used, the SMU pen table will plot the “Existing” element line styles at a reduced intensity and “Proposed” element line styles in bolded intensity to contrast and display importance.

4.2.3 Dimensions

For precision of dimensions, see Figure 1-2 of the *Structures Management Unit Design Manual*.

Used the following guidance to show dimensions on plans:

- Show dimensions that are less than 1-inch in fractions of an inch, without a leading zero (e.g. ½”)
- Show dimensions that are an inch or greater, but less than 12-inches, in whole inches and fractions of an inch (e.g. 4½”).
- For dimensions that are 12-inches or greater, show dimension units in feet, inches and fractions of an inch (e.g. 1’-3½”).
- Place horizontal dimension lines so they can be read from the bottom of the plan sheet with dimensions above the dimension line.
- Place vertical dimension lines so they can be read from the right side of the plan sheet with dimensions on the left side of the dimension line.
- Place inclined dimension lines so they can be read horizontally by rotating the plan sheet through the smallest angle possible.

4.2.3.1 Placing Dimensions and Notations

The NCDOT Workspace utilizes generalized dimension styles for all Technical Service Units.

For efficiency and standardization, SMU has created Element Templates that automatically select the correct generalized NCDOT text styles for plan production.

To place dimensions, go to the **Element Templates > SMU > Annotation > Dimension Lines**

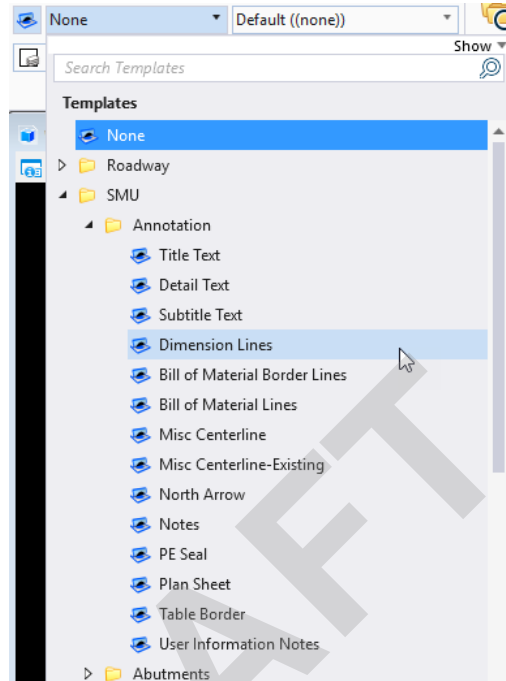

Then go to **Annotate > Place Text** tool, this will automatically set the text style set in the template. SMU utilizes the NCDOT “Fractions” dimensions style in the workspace.

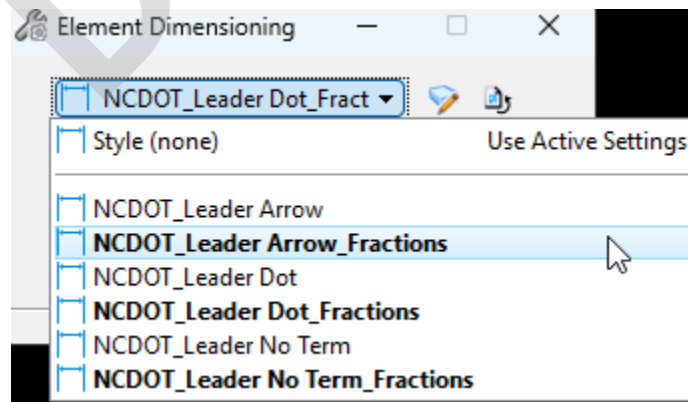

To place notations, go to the **Element Templates > SMU > Annotation > Notes**.

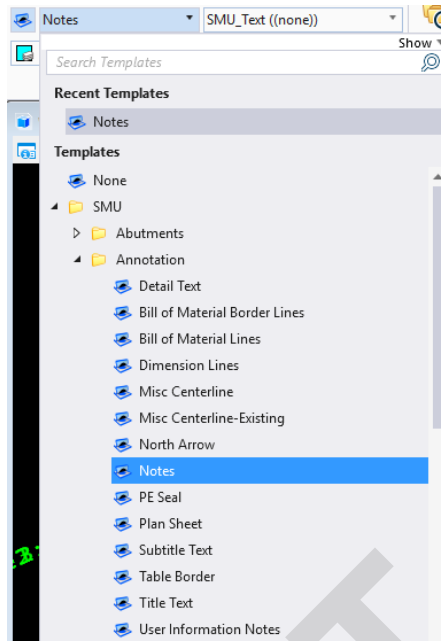

Then go to **Annotate > Place Text** tool, this will automatically set the text style set in the template. SMU utilizes the NCDOT “Fractions” dimensions style in the workspace.

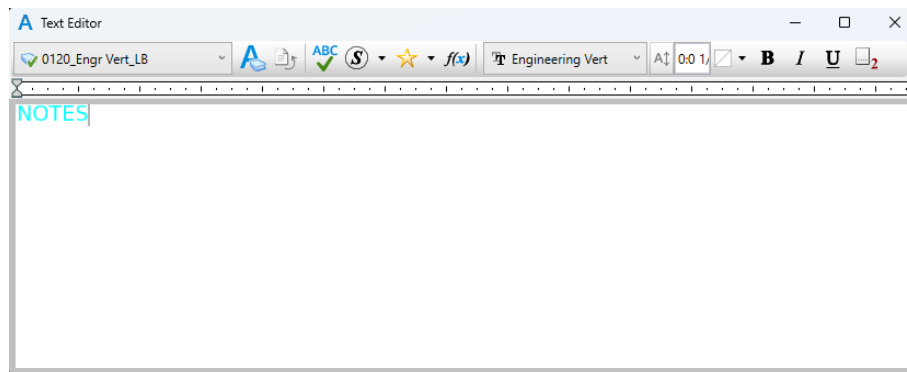
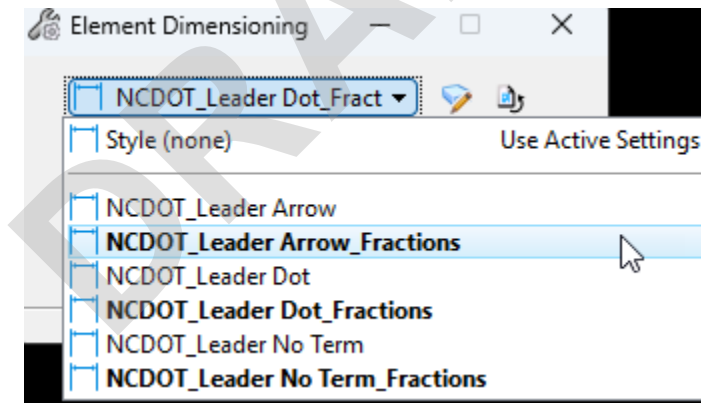

4.2.4 Text Properties

All text placed on plan sheets shall be capitalized.

The NCDOT Workspace utilizes generalized text styles for all Technical Service Units. The naming convention uses the following format:

(Text Size)_(Font Name)_(Justification)-(Additional setting)

For efficiency and standardization, SMU has created Element Templates that automatically select the correct generalized NCDOT text styles for plan production.

Go to the **Element Templates > SMU > Annotation > Detail Text** (or the desired text style: Notes, Subtitle, Title)

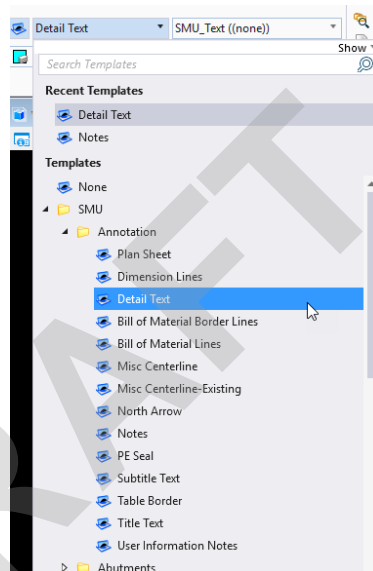

Then go to **Annotate > Place Text** tool, this will automatically set the text style set in the template. **Do not change any settings**, place text as normal.

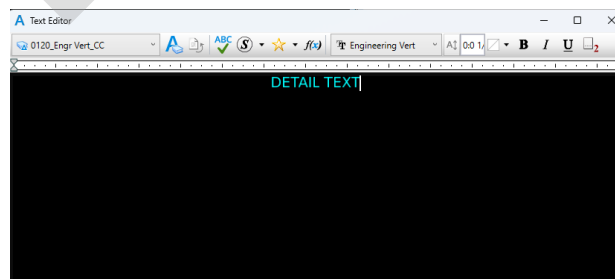

The following text styles are set for SMU plan production:

Dimension Text Style = 0120_Engr Vert_CC

Notes Text Style = 0120_Engr Vert_LB

Subtitle Text Style = 0160_Engr Vert Mono_CC

Title Text Style = 0210_Engr Vert Mono Bold CC

4.2.4.1 Title Block

The SMU title block is located in the lower right hand corner of SMU borders. The title block provides users a brief description of information presented on the plan sheet, the project number, the county where the project is located, the station where the structure is located along the alignment, sheet number, number of sheets in the plan set, etc. For additional information on what is required in the title block for the various plan sheets, see the *Structures Management Unit Design Manual*.

Use the following guidance for title blocks on plan sheets:

- Use SMU’s Title Text style for the Project Number (e.g. B-1000), County (e.g. WAKE), Station/Bridge Number (e.g. 10+00.00 -L-) sections of the title block, as well as the sheet title (e.g. GENERAL DRAWING).
- All Sheet titles shall be spelled out completely. (e.g. GENERAL DRAWING, TYPICAL SECTION, etc.)
- Use SMU’s Subtitle Text style for supporting sheet title information (e.g. BRIDGE ON SR 1000...).
- Abbreviations for supporting sheet title descriptions are acceptable when space is limited (e.g., W. 5TH ST. for WEST FIFTH STREET)
- Use SMU’s Detail Text style for additional title block information (e.g. SHEET 1 of 4, REPLACES BRIDGE No.) as well as the sheet number and total number of sheets.

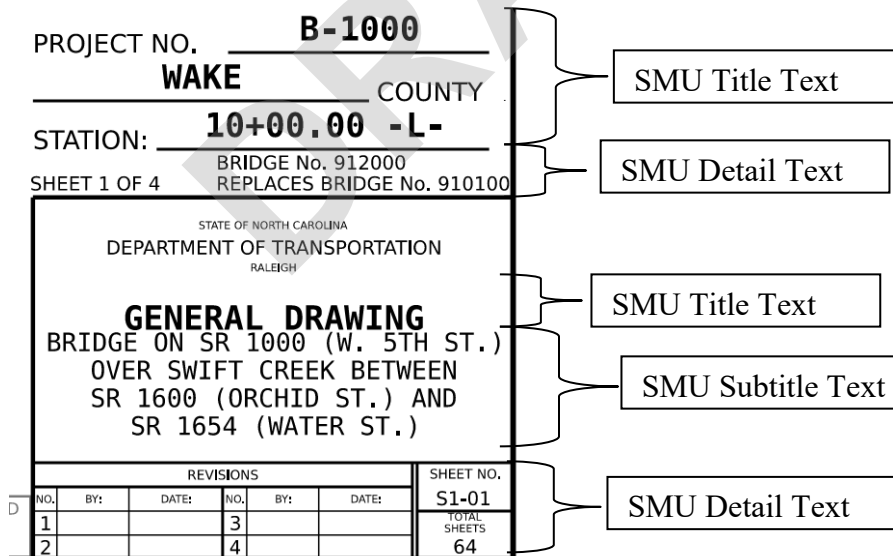

4.2.4.2 Professional Engineer Seals

Professional Engineer (PE) Seals shall be created and placed with the SMU PE Seal element template.

Go to the **Element Templates > SMU > Annotation > PE Seal**

Then go to **Annotate > Place Text** tool, this will automatically set the text style set in the template. **Do not change any settings**, place text as normal.

To create a customized PE, in a newly created DGN copy the *Create Seal* model in the SMU_PE_Seals cell library and follow the instructions in the model. For future reuse, save the newly created PE seal DGN in a location that can be easily referenced.

4.2.4.3 Names on Plan Sheets

For Drawn By, Checked By and Design Engineer of Record, use SMU’s Detail Text style.

When drawings are revised or updated by someone other than the original drafter, keep the original drafters name and use a forward slash and place the second drafters initials (e.g. DRAWN BY: J.A. DOE/B.C.H.). This also applies to checkers.

Do not use initials for the Design Engineer of Record.

DRAWN BY:	J.A. DOE/B.C.H.	DATE:	10/2025
CHECKED BY:	T.K. CHECKER	DATE:	11/2025
DESIGN ENGINEER OF RECORD:	GREGORY P. SEAL	DATE:	11/2025

4.2.4.4 Federal Aid Numbers

For labeling the federal aid number in the top right hand corner of the first general drawing sheet, use SMU Subtitle Text style.

F.A. PROJECT No. BRSTP-2000(4)



4.2.4.5 Notes and Legends

Use SMU’s Title Text style for labeling notes and legend titles.

For notes and legends, use SMU’s Notes Text style.

Legends shall provide symbols used to describe the items on a sheet.

REPAIR LEGEND

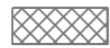
	SHOTCRETE REPAIR AREA		G#- GIRDER NUMBER
	CONCRETE REPAIR AREA	NF#-	NORTH FACE
		SF#-	SOUTH FACE
		UOG-	UNDERSIDE OF GIRDER

4.2.4.6 Details, Sections and Views

Labels for details, sections and views shall be SMU Title Text style.

When showing multiple views to detail the same element, use SMU Subtitle Text style to label the different views.

ELEVATION

PLAN

BENT DIAPHRAGM BLOCK-OUT DETAIL

Avoid using abbreviations for labeling details and views.

Use lettered section labels for each bridge component (e.g. SECTION A-A). Continue lettering section labels A to Z through all plan sheets related to a component. Details and section views do not need to be on the same sheet(s) as where they are called out, if they are not on the same sheet indicate on the call out what sheet to see.

Letters used for sections may repeat for each new bridge component. Avoid the use of double lettered sections (e.g. SECTION AA-AA).

4.2.5 Detailing Reinforcing Steel

For reinforcing steel detailing requirements, see Section 10.4 the *Structures Management Unit Design Manual*.

For bar callouts, use SMU Notes Text style and the NCDOT_Leader Arrow_Fractions dimension styles.

Reinforcing steel shall be labeled by using the following name convention:

Number of bars-#Bar Size Bar Location ID_Bar Label, Sequence

Identify reinforcing steel first by the number of bars, the bar size, the bar location I.D., the bar label, and the spacing. (e.g. 4-#4 D_B3 @ 6” CTS.) If only one bar is being identified, start the with the bar size. (e.g. #4 A_B1 BAR) See bar location I.D.’s and bar label tables below.

Use abbreviations and symbols to reduce clutter. The following are commonly used:

Abbreviation/Symbol	Description
@	At
B.B.	Beam Bolster
B.B.U.	Beam Bolster Upper
C.H.C.U.	Continuous High Chair Upper
CL.	Clear
CTS.	Centers
DBL	Double
Ø	Diameter
DIAPH.	Diaphragm
EA.	Each
EQ.	Equal
RAD.	Radius
REQ'D	Required
SPA.	Spaces
THRU	Through
TYP.	Typical

4.2.5.1 Bar labels

Bar labels start with the bar location I.D. which corresponds to the element where the bar is located.

Bar Location I.D.	Bridge Component
A	Abutment/End Bent and foundations
B	Bent and foundations
C	Culvert
D	Deck
G	Girders & Diaphragms
M	Median islands and sidewalks
R	Barrier Rails
S	Approach Slabs
W	Wing Walls and Walls

Start label sequences at one through ninety-nine.(e.g. A1, A99) When introducing cut bars into a section with straight bars, such as skewed bridge decks, start the sequence counting at one-hundred and one. (e.g. A101)

Label	Description
A	Main top bars and bottom bars of same size
B	Main bottom bars, if not same as top bars
C	Culvert longitudinal bars
D	Dowels
E	Parapet end post vertical bars
F	Parapet end post horizontal bars
G	Deck edge beam bars
H	Horizontal bars
J	
K	Diaphragm bars
L	
M	Drilled Pier vertical bars
N	
P	

R	
S	Stirrups
SP	Spiral Steel
T	
U	“U” shaped bars
V	Vertical bars
W	
X	
Y	
Z	

4.2.5.2 Bill of Materials

Provide bill of material tables as described in Section 10.4.4 the *Structures Management Unit Design Manual*.

SMU has developed Bill of Material seed templates. To place bill of material tables, go to **Annotate > Place Tables** tool. Select the appropriate SMU Bill of Material seed.

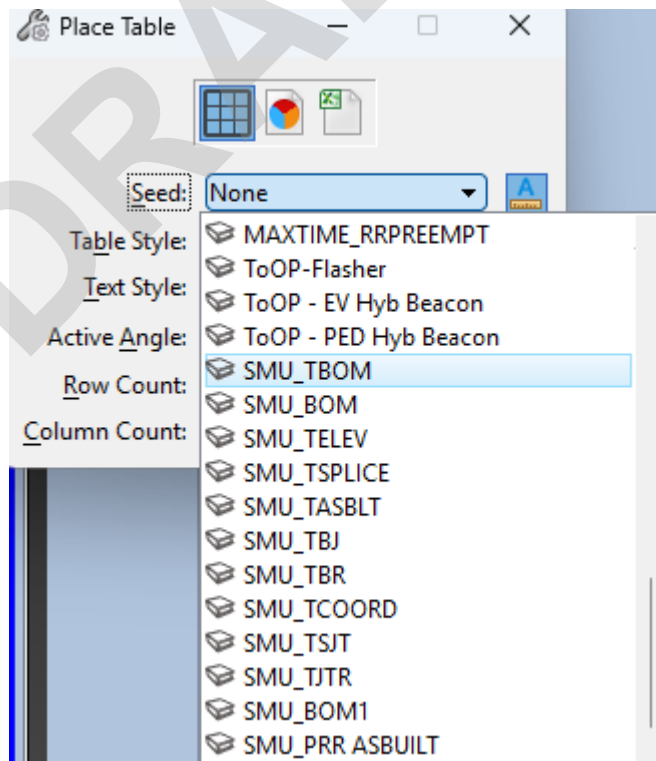

Use SMU Detail Text style for the Bill of Material values.

Identify bar types in Bill of Materials from the Bar Bending Details Standard.

For bent bars, provide a sketch per Bill of Materials with leg dimensions and bend offsets using the bar types from the Bar Bending Details Standard.

4.2.6 Cell Libraries and Steel Shapes

Cell Libraries

Cell libraries match the Element Templates.

To place cells, go to **Annotate > Place Active Cells** tool.

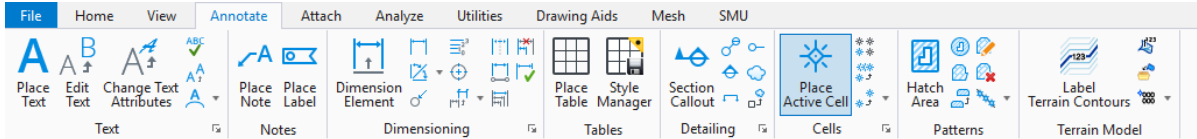

To select the cell library, click on the dots next to Active Cell.

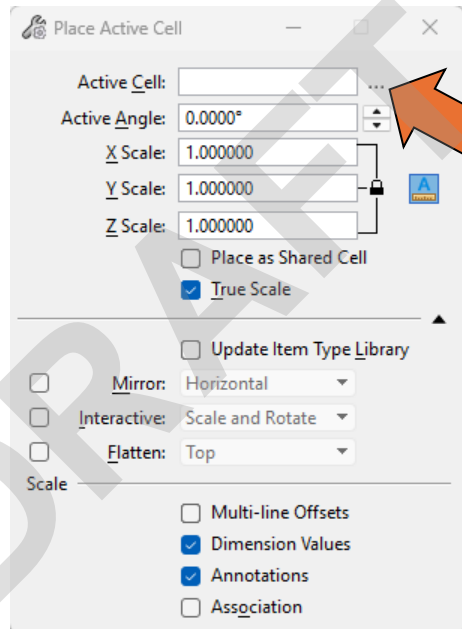

Under File, select the appropriate cell library in the list.

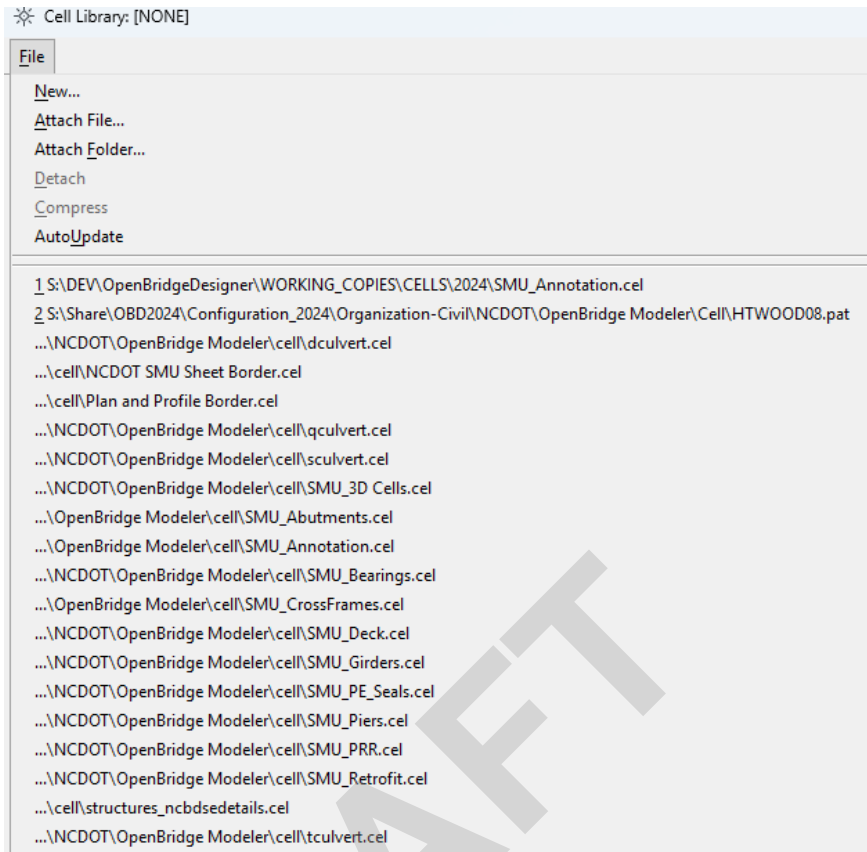

Once a cell library is selected, the list of cells within that library will be displayed.

Cell Library: [S:\Share\OBD2024\...\SMU_Annotation.cel]

File

Name	Description	Type	Active
AH	DRAFT	Graphic	
AS-BUILT NOTE	PLACE ON GED AND OR CULVERT	Graphic	
BAR BILL OF MAT	MISC	Graphic	
BREAK SYMBOL	DRAFT	Graphic	
BT BILL OF MAT	BENT	Graphic	
COMPUTATION SHEET	DRAFT	Graphic	
COMPUTATION SHEET 1	DRAFT	Graphic	
CONCRETE PATTERN	PATTERNS	Graphic	
DEFLECTION TABLE 10 POINTS	MISC	Graphic	
DEFLECTION TABLE 20 POINTS	MISC	Graphic	
DEFLECTION TABLE 30 POINTS	MISC	Graphic	
DEFLECTION TABLE 40 POINTS	MISC	Graphic	
DEFLECTION TABLE 60 POINTS	MISC	Graphic	
DEFLECTION TABLE GIRDER	MISC	Graphic	
DEFLECTION TABLE GIRDER 10 PO...	MISC	Graphic	
DEFLECTION TABLE PCG 10 POINTS	MISC	Graphic	
DESIGN ENGINEER OF RECORD	DRAFT	Graphic	
DOT	DRAFT	Graphic	
DOUBLE ARROWHEAD	DRAFT	Graphic	
E COMPUTATION SHEET PCG	ENG	Graphic	
E COMPUTATION SHEET STL	ENG	Graphic	
EARTH PATTERN	PATTERNS	Graphic	
GRAVEL PATTERN	PATTERNS	Graphic	
INDEX TABLE	MISC	Graphic	
LLT	Draft	Graphic	
NC SYMBOL 1	DRAFT	Graphic	
NORTH ARROW SYMBOL	DRAFT	Graphic	
PRELIMINARY PLANS NOTES	DRAFT	Graphic	
PRR Field Work PS	LIST	Graphic	
PRR PS	LIST	Graphic	
PS	LIST	Graphic	
PS TITLE BLOCK	Title Block for Design PS	Graphic	
REVISION SYMBOL	DRAFT	Graphic	
RIPRAP PATTERN	PATTERNS	Graphic	
ROCK PATTERN	PATTERNS	Graphic	
S TOTAL BILL OF MAT	STEEL	Graphic	
SEAL BOX	LIST	Graphic	
SECSYM	DRAFT	Graphic	
SECSYM - Copy-1	DRAFT	Graphic	
SN	LIST	Graphic	
SN2	LIST	Graphic	

To place a cell, double click on the cell in the list and place it in the model.

Steel Shapes

Bentley’s steel shape application has been placed in the workspace and will open automatically with the workspace.

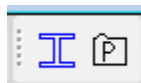

To use the tool, first click on the right folder icon and set the Steel Section Parameters.

Set Color and Weight to “By Level” and select the appropriate level for the section being placed.

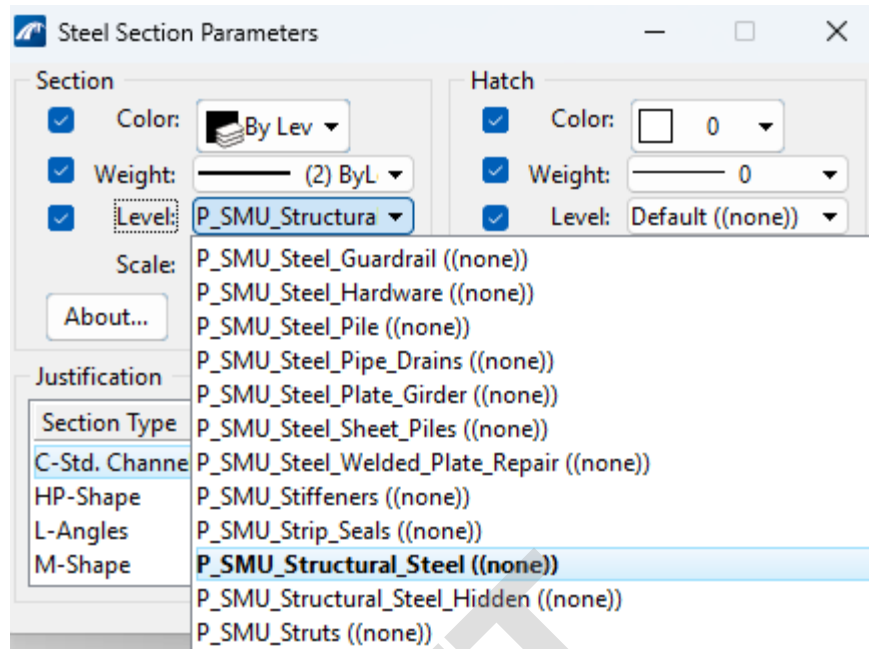

Then click on the left icon to Place the Section, use the usLRFDv3 Section table.

Select the appropriate Type (e.g.: W-Shape, etc.) and section Name (e.g.: W6x15) and Hatching style (e.g.: None, Hatch, Fill)

The section will appear and be ready to be placed in the model.

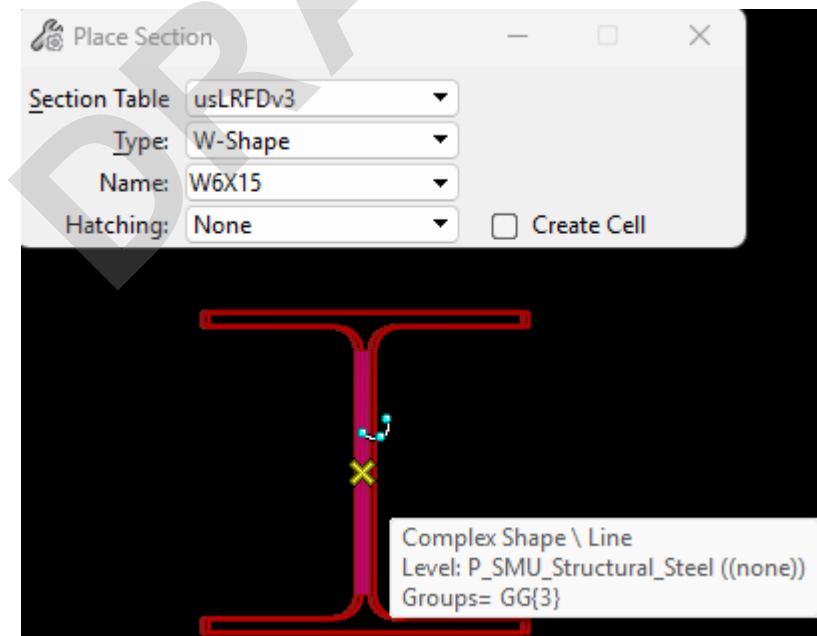

4.2.7 Plan Revisions

Plan revisions made after letting require the following:

After the necessary revisions have been made, the person making the revision shall put their initials and the date in the title block. Use SMU’s Notes Text style.

A brief description of the revision should be placed next to the title block. The initials of the person making the revision, the date of the revision, the initials of the person checking the revision and the date checked should be included at the end of the description.

A triangle, ▲, with the revision number in it should be placed next to the description and the corresponding revision.

▲ 1	REVISED QUANTITIES 02/25/22	DOCUMENT NOT CONSIDERED FINAL UNLESS ALL SIGNATURES COMPLETED	NO.	BY:	DATE:
			1	NAP	02/25/22
2					

Revise the sheet number to include a “R” for revision and the revision number (e.g. S1-14R1)

Revise the total number of sheet to also include a “R” to indicate the total number of sheets has been revised (e.g. 64R1)

4.3 DRAWING WORKFLOW

Once the DGN file is created as laid out in Chapter 3, for 2D drawing creation set OBD to the Drawing Workflow.

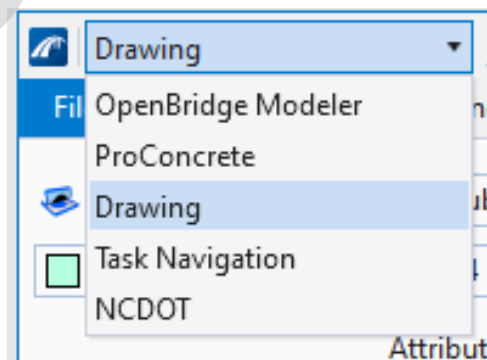

All DGN files will be set up with three modes with them:

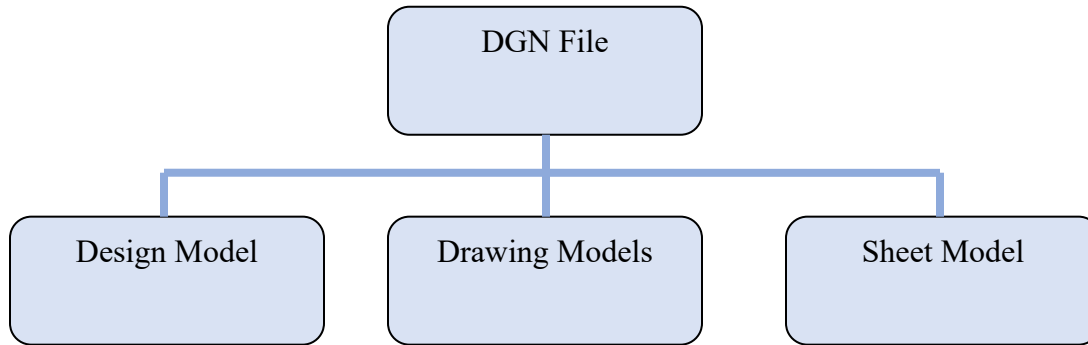

Use the Drawing tools like the Place Name Boundary tools, as detailed in Chapter 3, to get drawings from the Design Model to the Drawing and Sheet Models.

4.4 DEFAULT (DESIGN) MODEL

For 2D drawings the Default (Design) Model will be used to draw proposed or existing structure elements in a 2D view at full scale (1:1) in their correct geographical locations. Reference the SMU Design Manual for all required content for the plan sheet being created.

To set the DGN to look like it did in v8, in the Design Model close the “View 2” window and maximize the “View 1” window, then use the save settings tool. (Note: View 2 is utilized for 3D isometric views.)

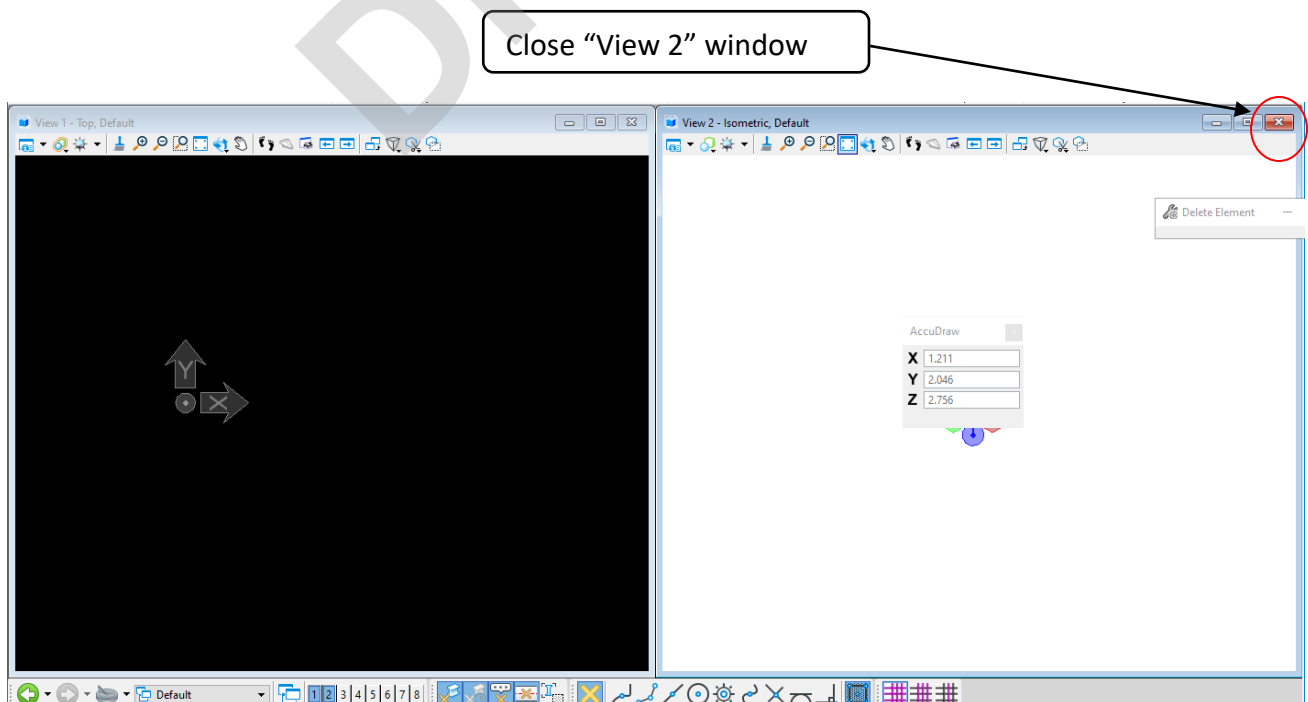

Leave the Drawing Scale at the defaulted scale of 1"=50' and draw all elements at their true dimensions.

4.5 DRAWING MODEL

For 2D drawings, the Drawing Model is used to annotate the drawings done in the Design Model. This can be achieved by referencing the drawing done in the Design Model or using the drawing tools to place a view of the drawing in the Design Model into the Drawing Model.

After the Design Model has been referenced, it is time to set the Drawing Scale based on the reference view scale used in the Sheet Model for the drawing view.

4.5.1 Drawing Scale

Once the Design Model has been referenced in, it's time to select the drawing scale to annotate the drawing.

1st Select the Utilities tab

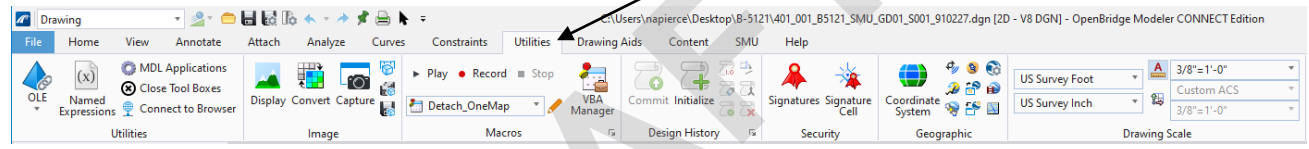

2nd Change your Drawing Scale from the defaulted "Full Size 1=1" scale to match the scale used referencing this drawing into the Sheet Model

Your scale is now set for this Drawing Model, save settings and do not change it unless the reference scale on the Sheet Model is changed. Now you can place your text.

Save settings

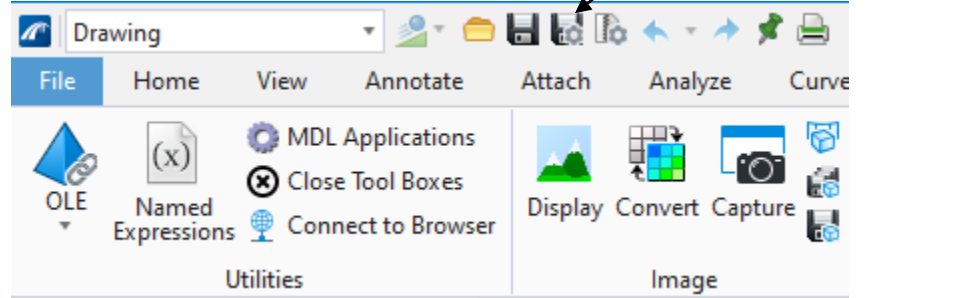

Once the Drawing Scale matches the Sheet Model reference view scale, it's time to start placing dimensions. Follow these steps to place dimensions:

4.6 SHEET MODEL

For 2D drawings, the Sheet Model is used to place the Plan Sheet Border with it's labels, plan sheet notes and bill of material tables.

4.6.1 Individual Plan Sheet Borders

Once the Sheet Model is set up and ready for a border, follow these steps to place an individual sheet border in the Sheet Model:

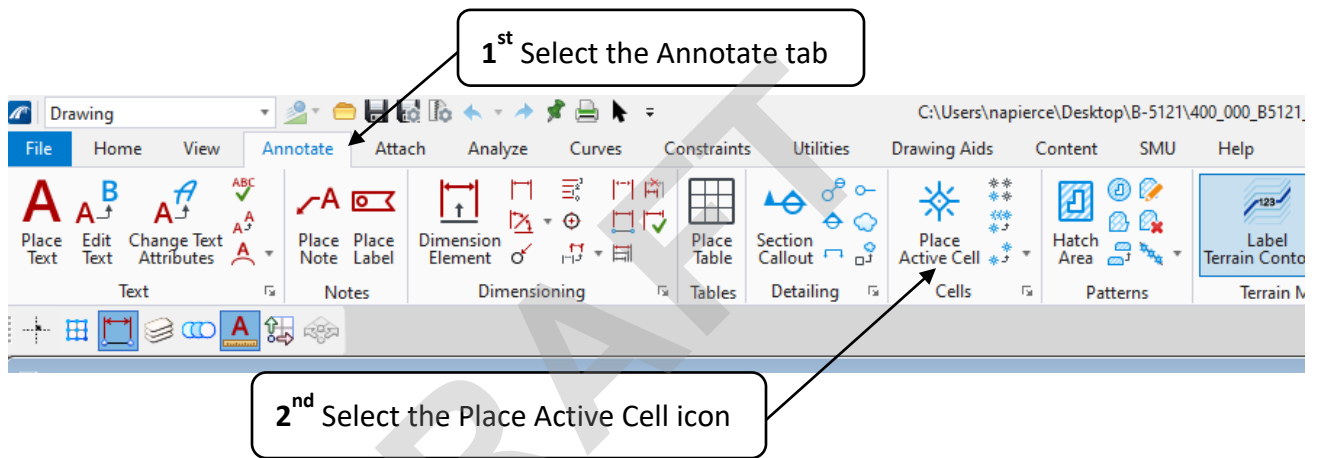

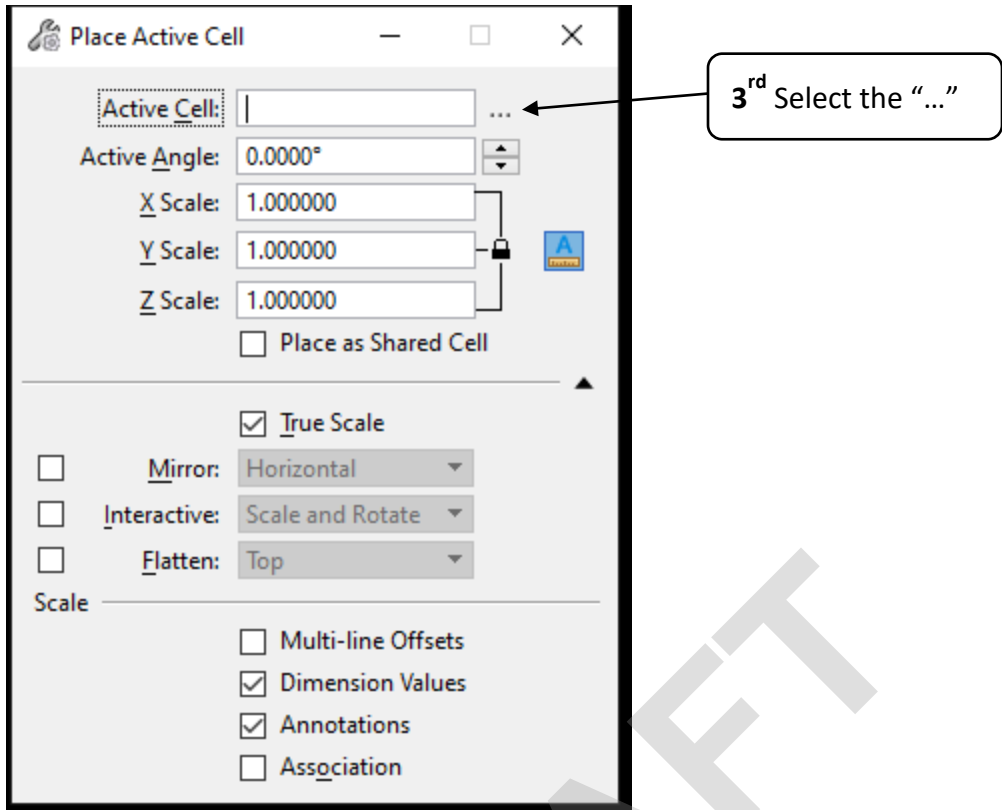

☀ Cell Library: [NONE]

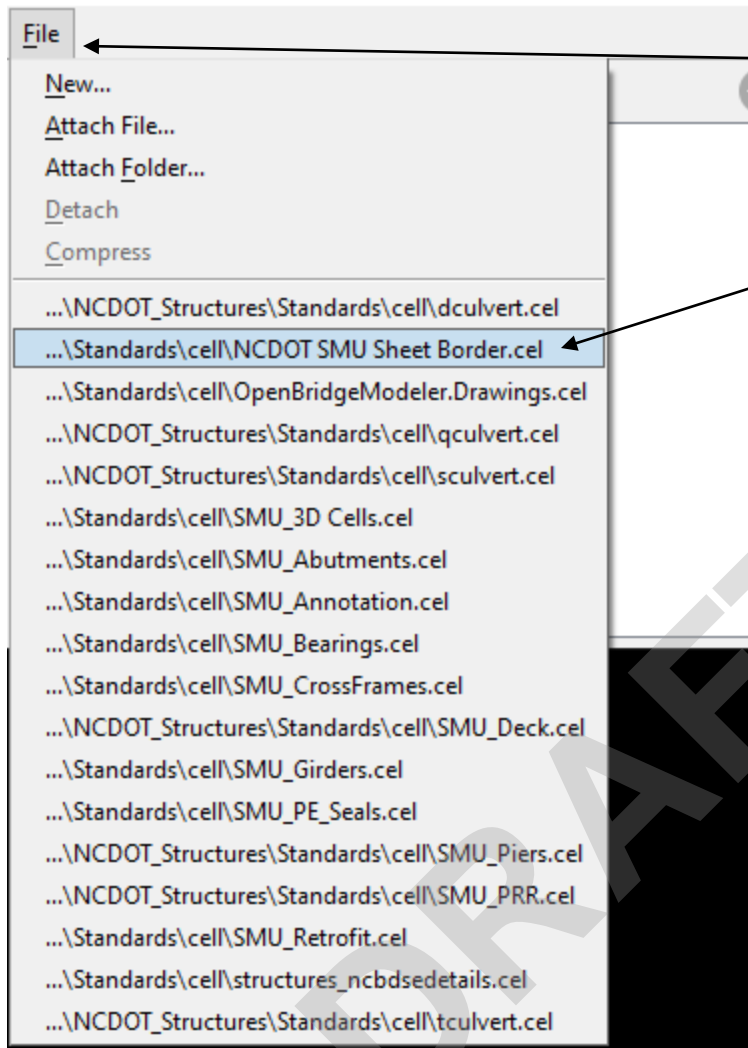

3rd Click on "File"

4th Select the SMU Sheet Border Cell Library

5th Double click on the correct border for the DGN

☀ Cell Library: [S:\Share\...\NCDOT SMU Sheet Border.cel]

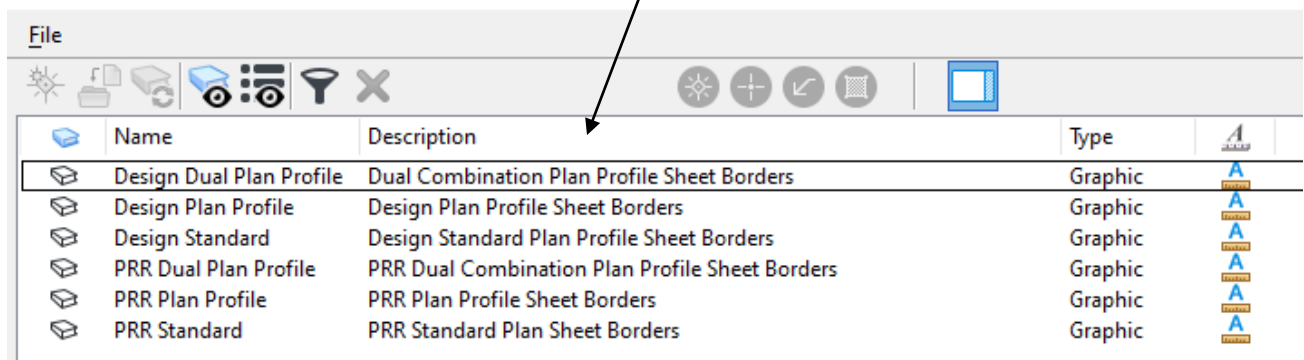

The border can now be placed as a cell in the sheet model.

4.6.2 Referencing A Master Structure Border

This method allows the user to set up a master border for each structure on the project, so that the users only has to go into one file to fill out the project number, county, and station/bridge number as well as place a PE seal and Total Number of sheets for the entire project. To use this method, create a Master Border DGN file for each structure on a project following the steps found in Chapter 4, which will be later referenced in your plan sheets.

4.6.2.1 Creating a Master Border DGN File

Create a new DGN file without adding Drawing and Sheet Models, in the Design Model follow these steps:

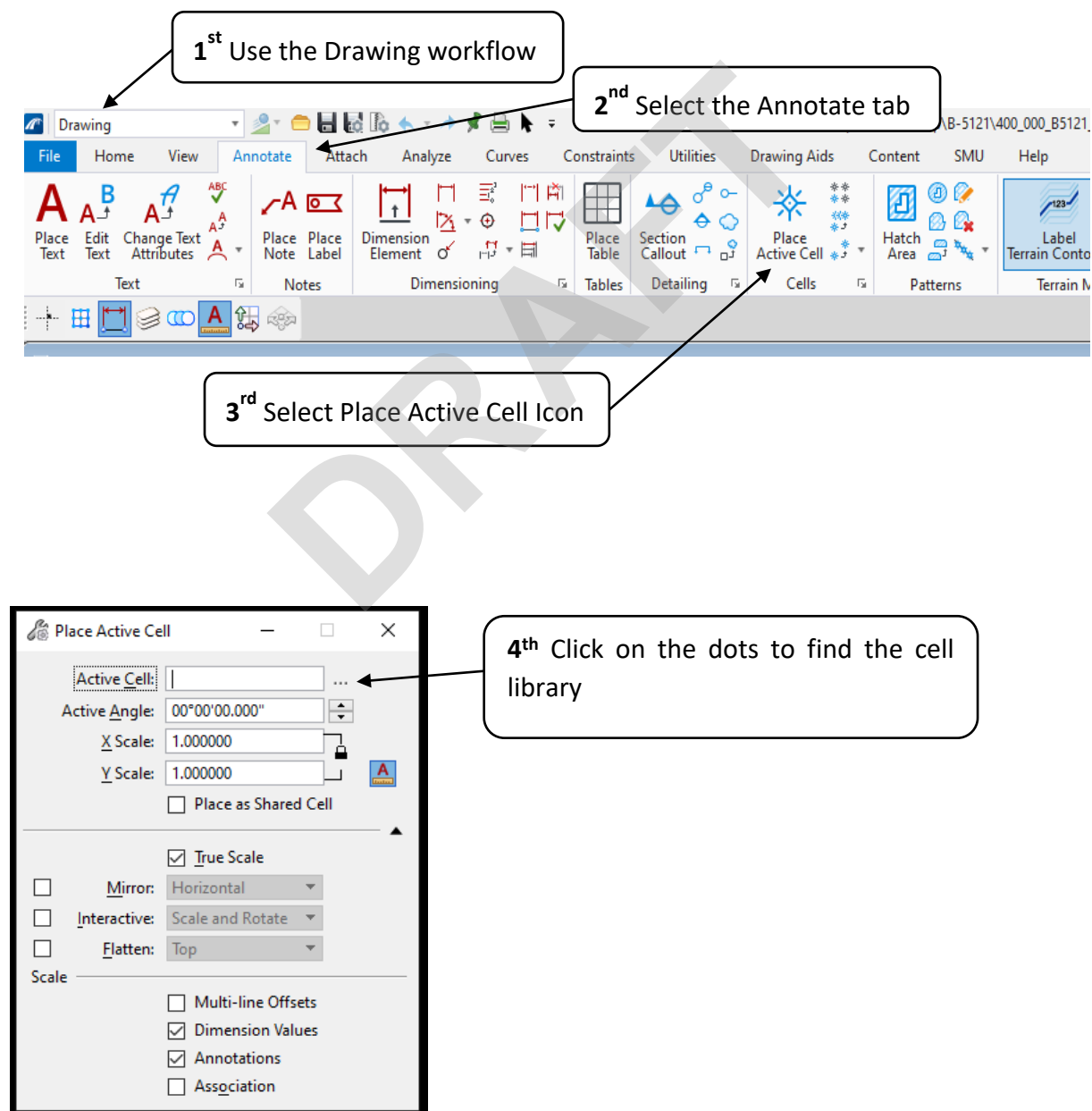

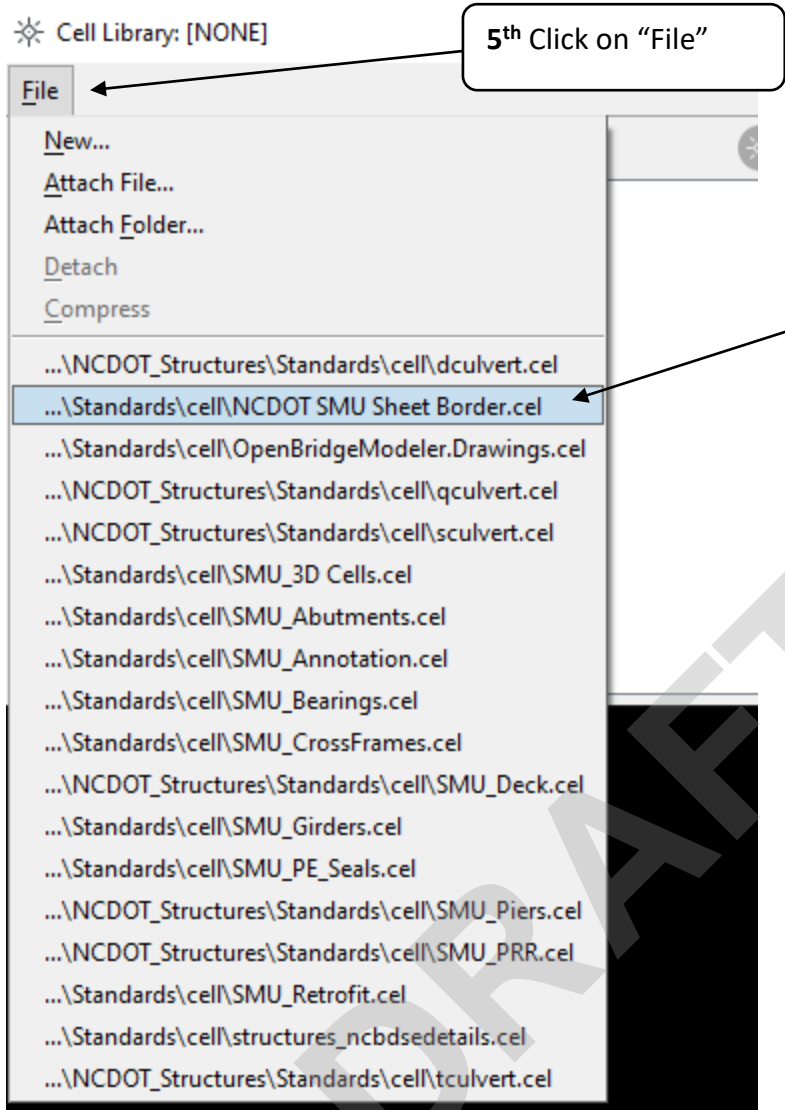

7th Select the Design or PRR Plan Profile Sheet

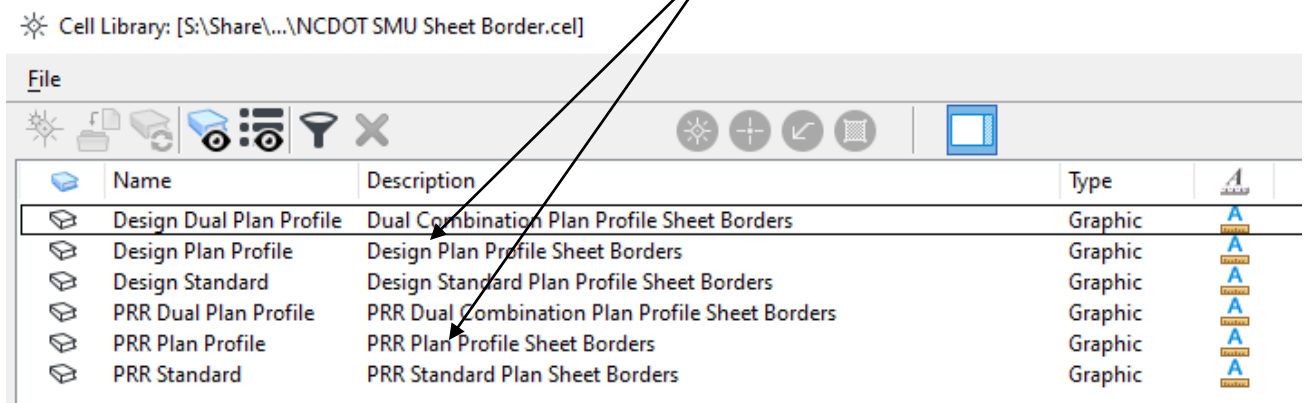

Place the border in the dgn Design Model at the axis origin point. Note the border will come in small, use the “Fit View” icon to zoom in.

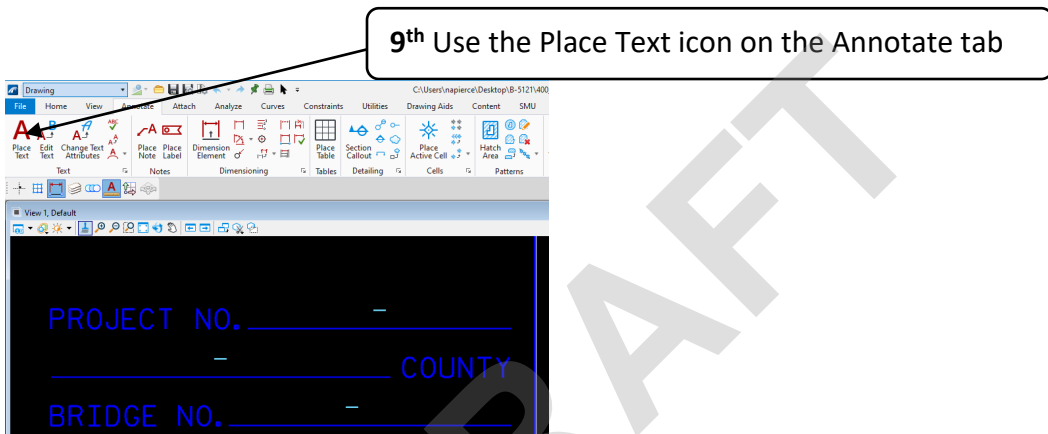
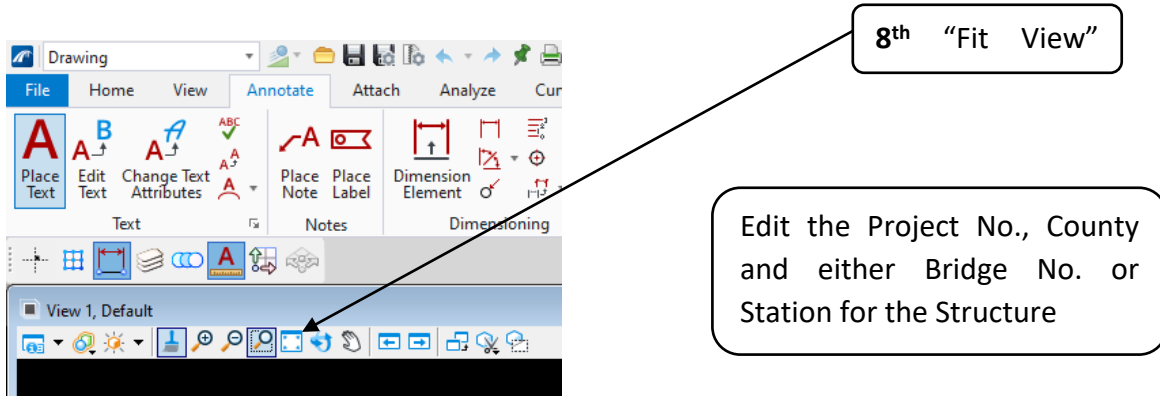

- Note: The only items to be edited in a Master Border should be:
- Project No.
 - County
 - Station/Bridge No.
 - Total Sheets
 - PE Seal

Save settings and exit file.

4.6.2.2 Referencing a Project Master Border

Once the Sheet Model for each project DGN file is set up and ready for a border, follow these steps to reference in the master sheet border into the Sheet Model:

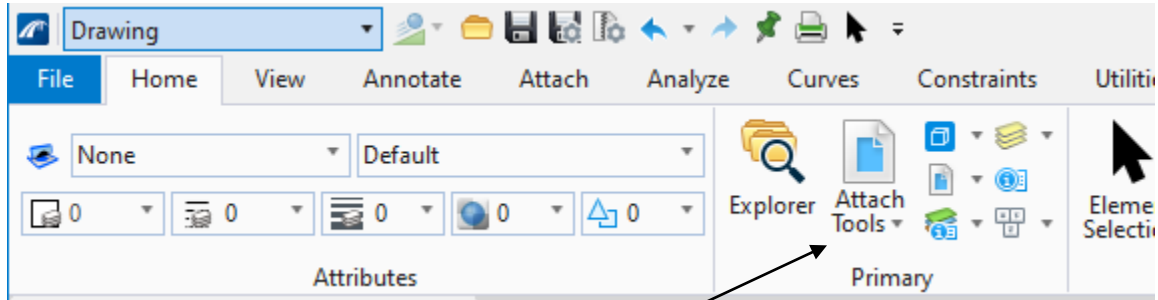

1st Select the Attach Tools icon

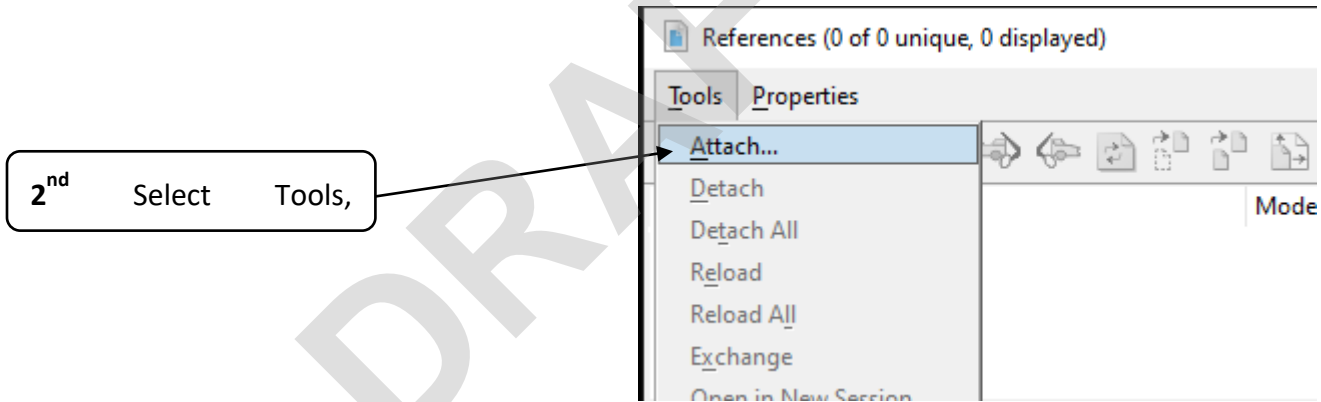

2nd Select Tools,

3rd Locate the Primary Border in the project folder created for the structure being drawn

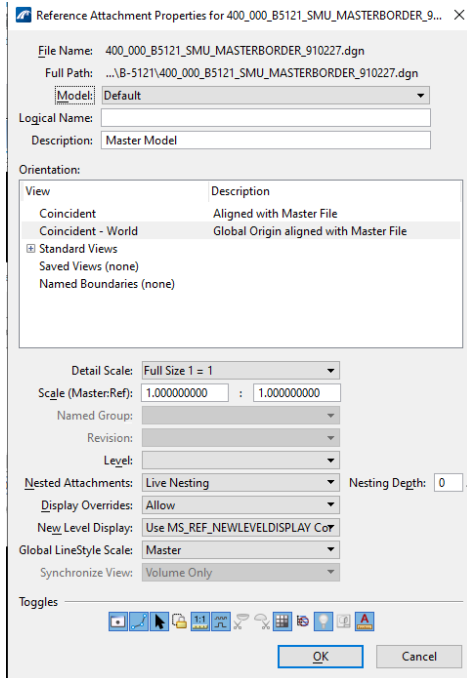

The reference should come in with the correct settings and not need changing.

The border will sometimes be off of the set sheet, and often not be in view of the set sheet. Use the “Fit View” icon to find stray referenced borders. To move it using the “Move Reference” tool...

Change Nesting Depth to 99

4th Select the attached file

5th Use the Move Reference tool to move the border on to the set print fence

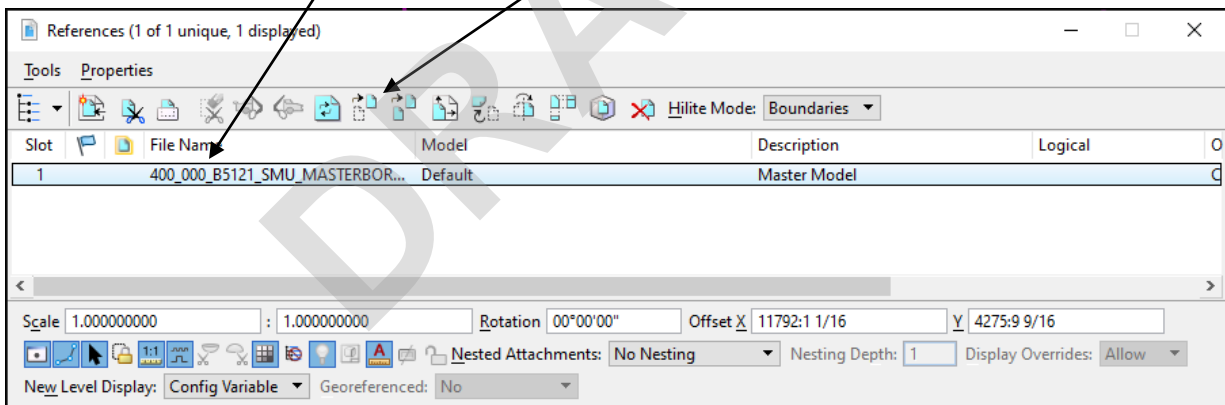

The Sheet Model scale should be left at “Full Size 1=1”.

6th Once the border is placed, the following items need to be placed in each DGN file on the referenced Master Border:

- Drawn By & Date
- Checked By & Date
- Engineer of Record
- Title
- Sheet Number
- Sheet _ of _

4.6.3 Placing Plan Notes with the SMU NOTES App

The SMU Notes tool is defaulted to look for the SMU notes on the SMU server. Consultants using the tool will need to create a folder on their C-drive to copy and paste the .nts files from the SMU website.

To change the tool target folder, click on the “Load .nts from folder” button and navigate to the local .nts folder.

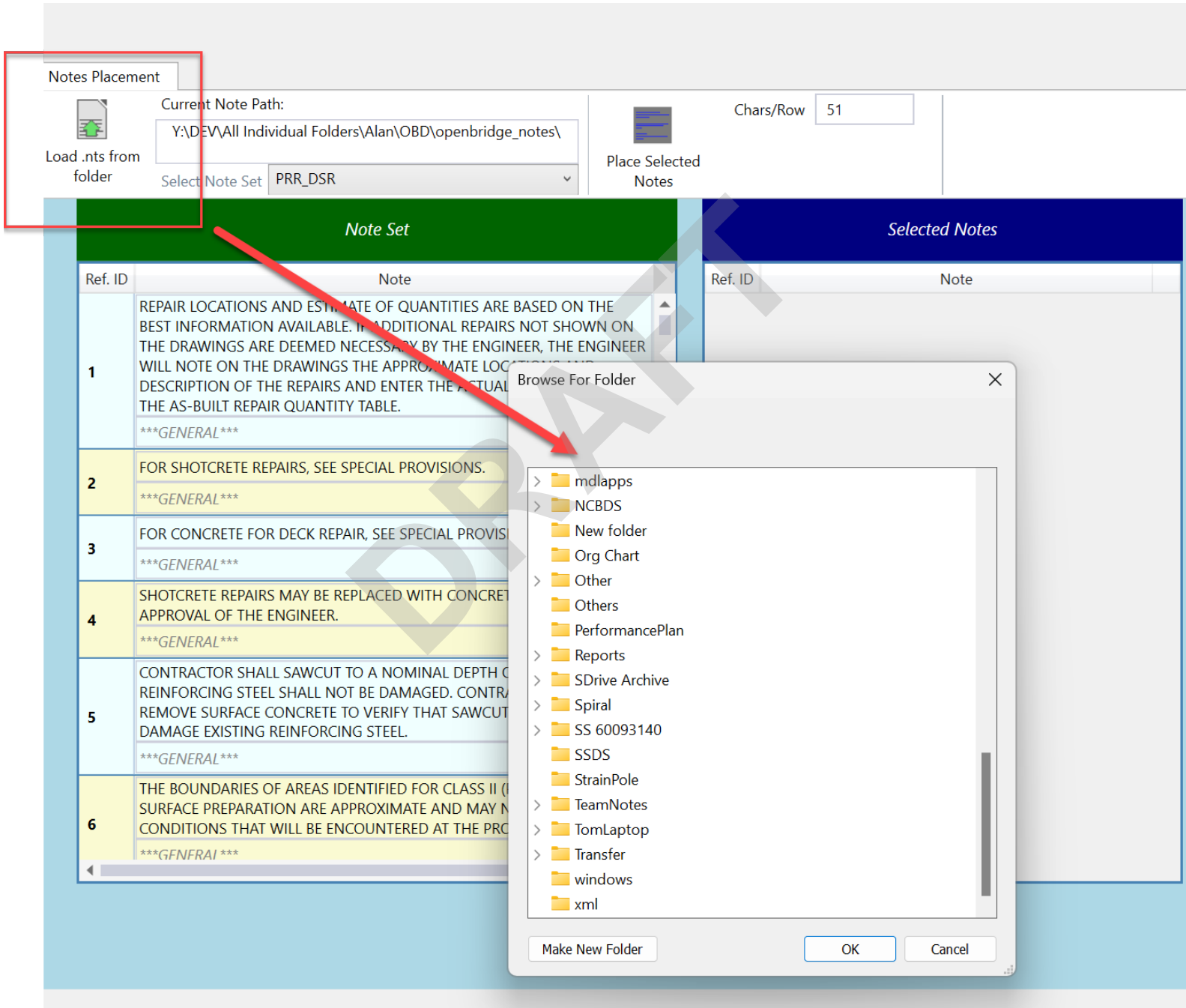

To place standard SMU plan notes on the Sheet Model, follow these steps

Select the SMU Notes text from the Annotation Element Template

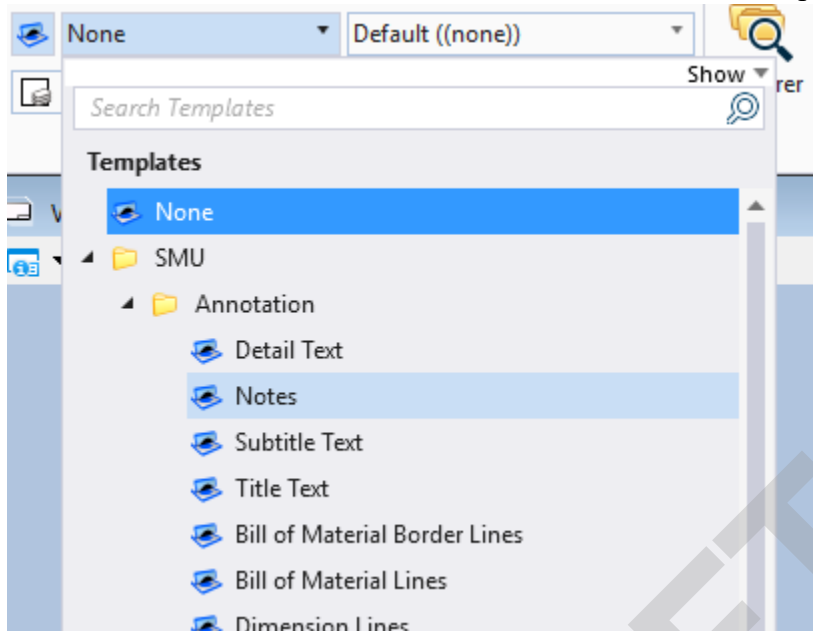

Then open the **SMU > NOTES** app

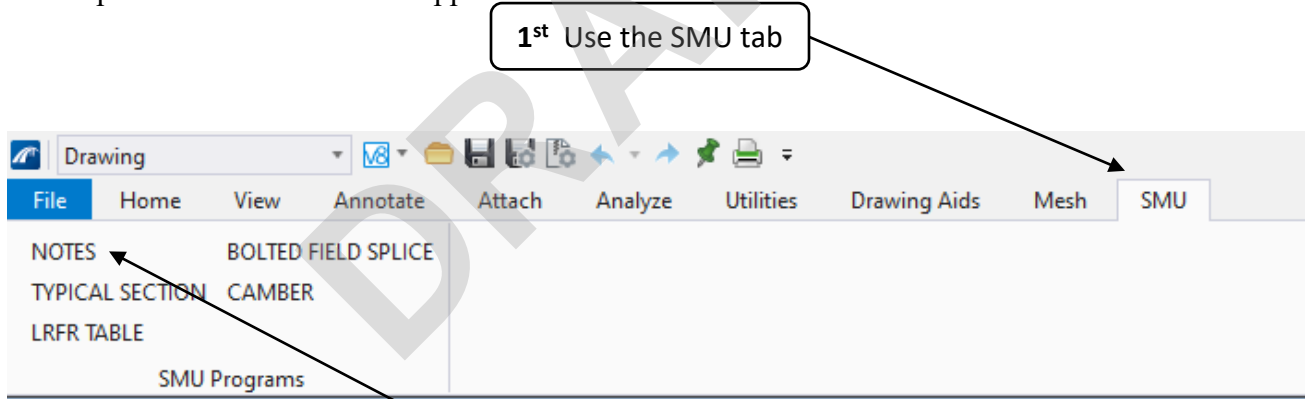

2nd Use the SMU Notes button for placing standard SMU plan notes

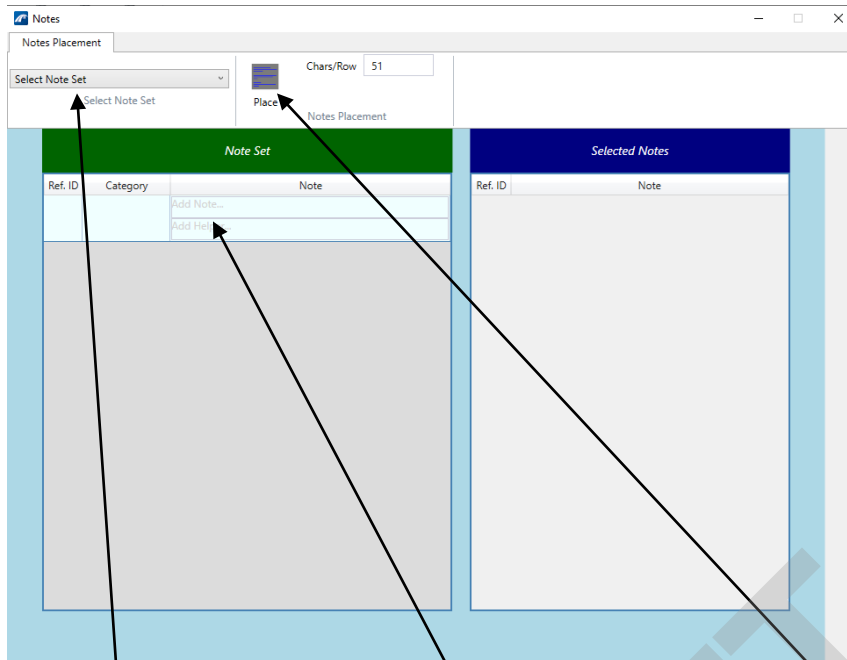

3rd Use the drop down to select the note set

4th Select the desired notes from the list

5th Use the “Place” button to place the selected notes in your dgn

Note that you can change the number of characters per row by editing the number.

4.7 PRINTING PDF’S

All printing should be generating full scale (ANSI D, 34x22) PDFs, which can be physically printed to any size paper when printing from your PDF viewing software.

To avoid issues with font symbols not printing, go into the workspace (\Configuration_2024\Organization-Civil\NCDOT\Fonts) and copy the true type fonts (.ttf) files and paste them into C:\Windows\Fonts.

4.7.1 References

Referenced files showing existing elements shall be grayed back to indicate they are existing versus proposed.

To gray back reference files, in the Sheet Model go to **Primary Tools > References**, then select the referenced files to be grayscale.

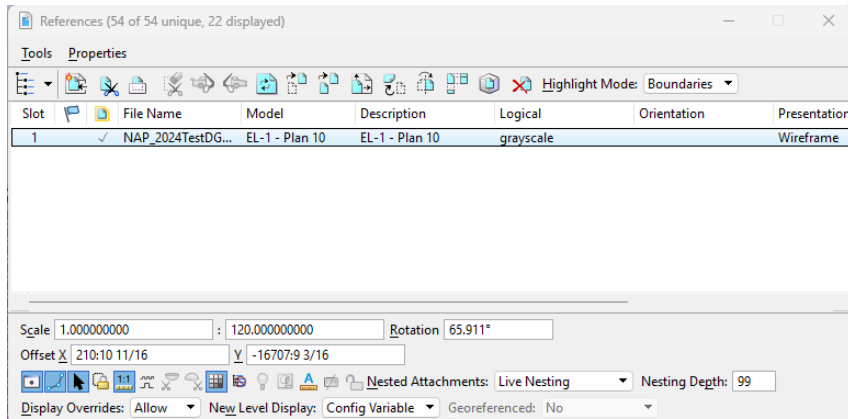

Double click on the files to open.

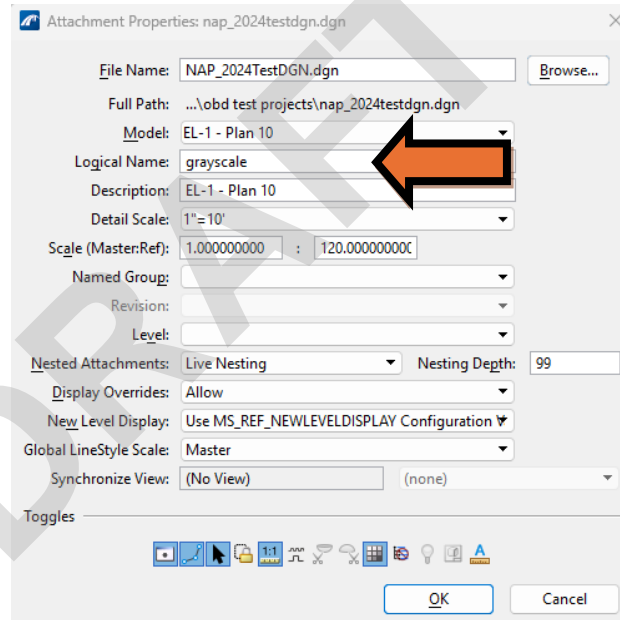

Change the Logical Name to “grayscale” and click “OK”.

4.7.2 Creating a PDF Document from a Single DGN

To PDF a single plan sheet file, from the Sheet Model follow these steps:

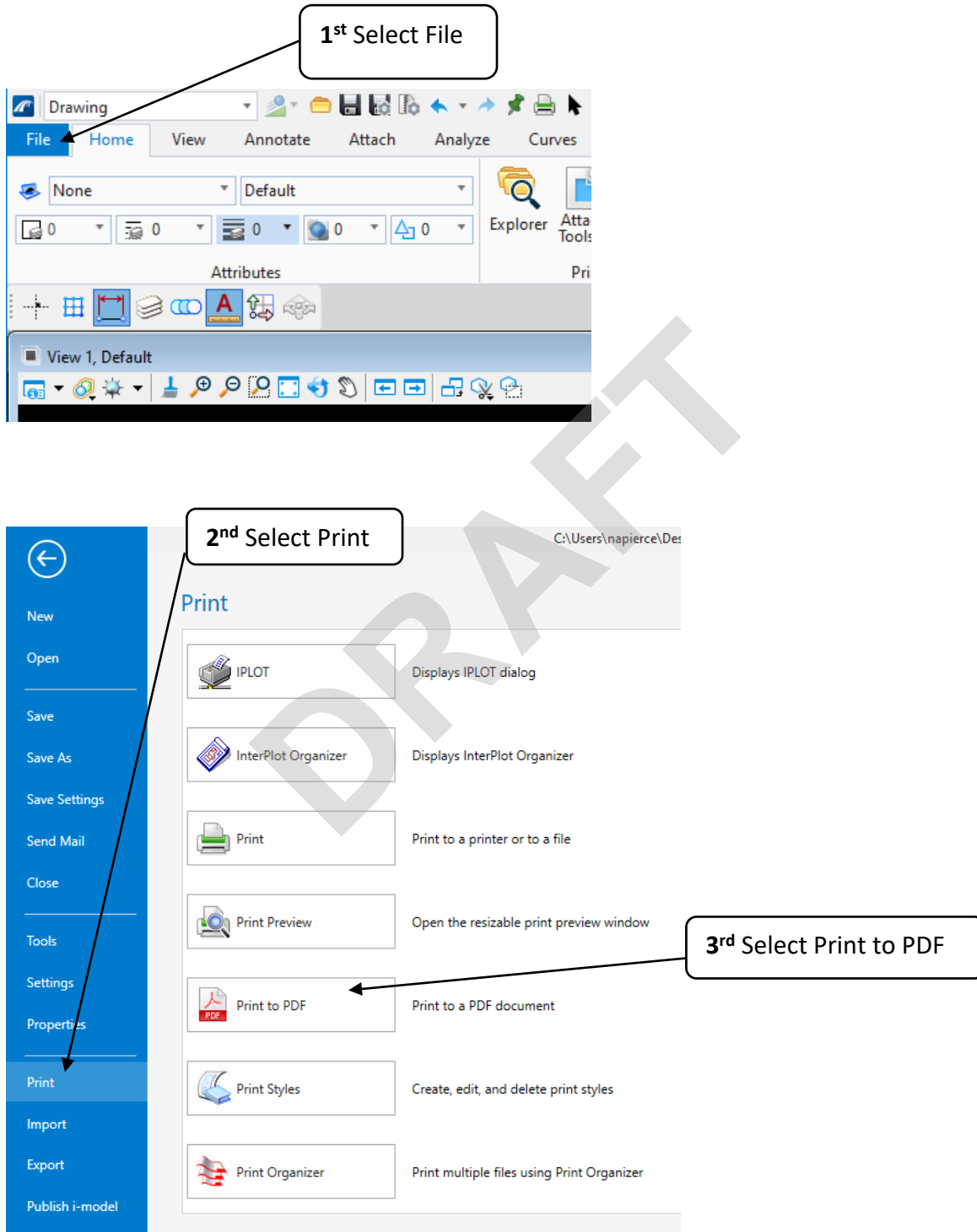

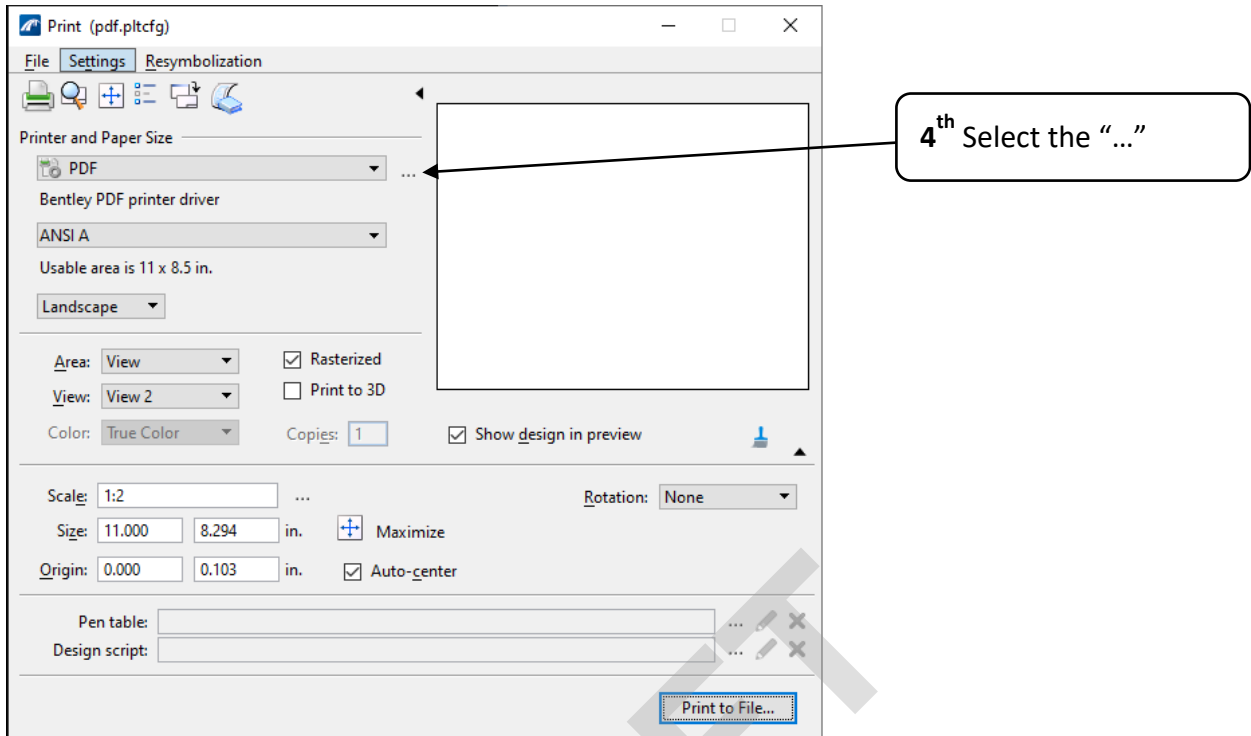

Direct the Select Printer Driver Configuration File tool to the following path:

NCDOTProduction/Documents/Administration/WorkspaceGroups/NCDOTWorkspaces/Configuration_2024/Organization-Civil/OpenBridge Modeler/plot

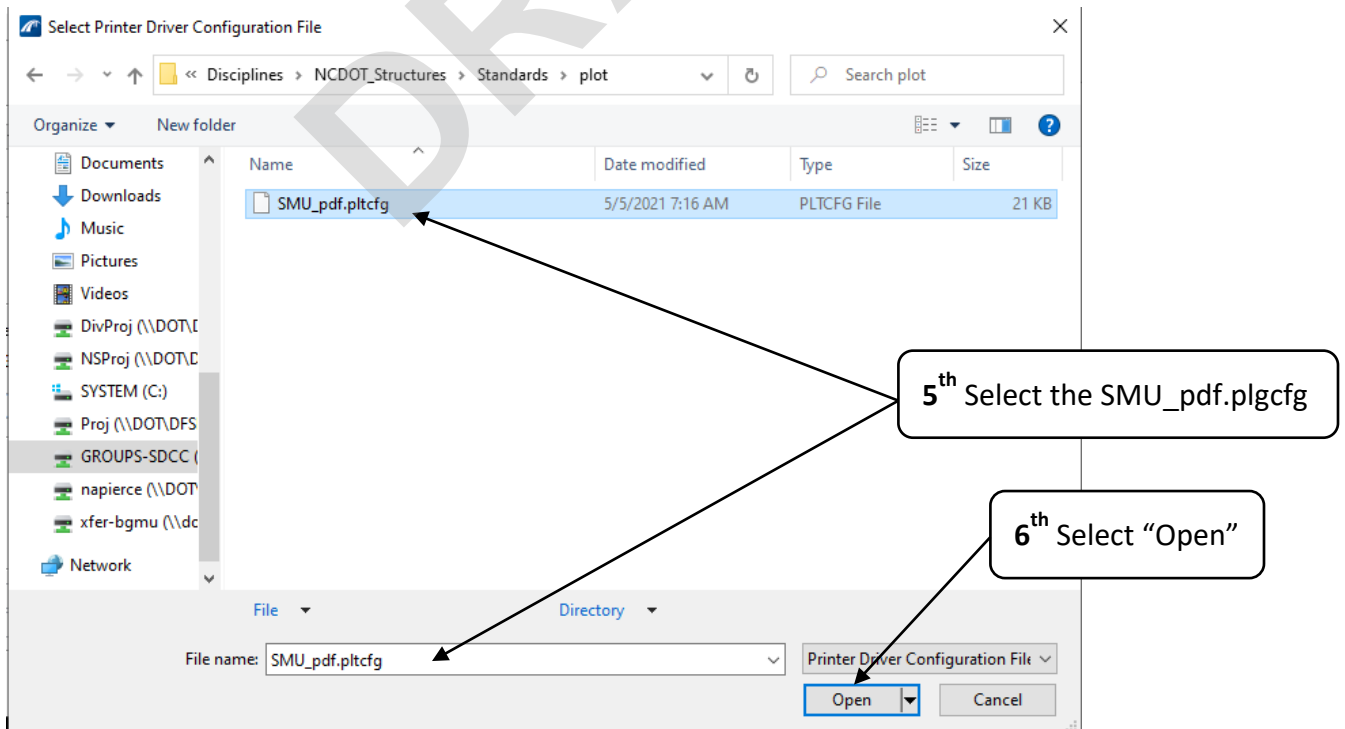

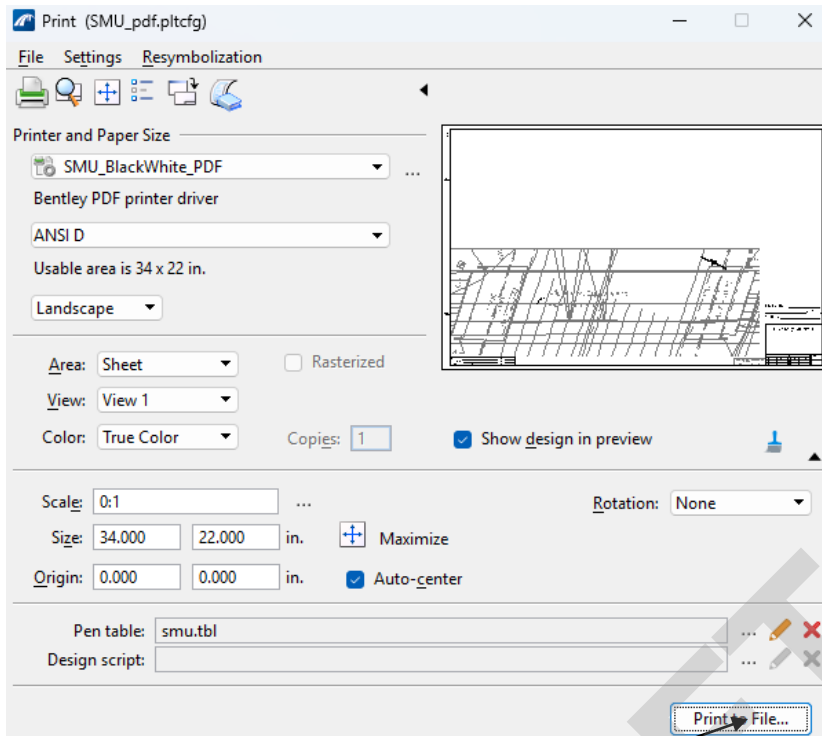

7th Print to File

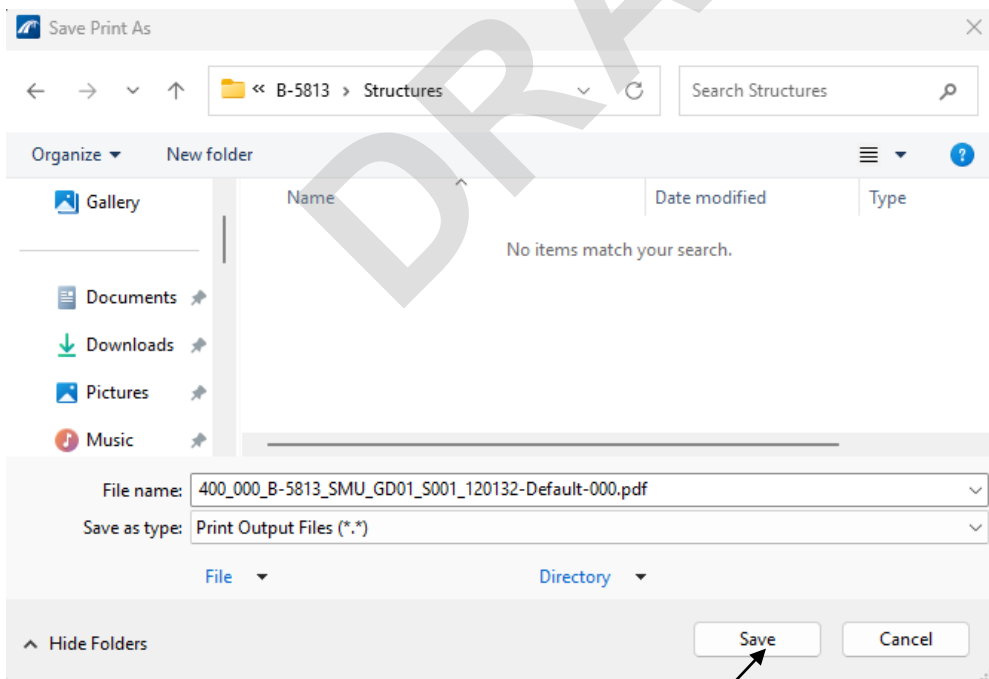

8th Save the file in the Project Folder

To print to paper, open the file in Adobe or BlueBeam and print from there.

4.7.3 Using Print Organizer for PDF Creation of Multiple DGN's

To PDF your plan sheet set DGN files, follow these steps:

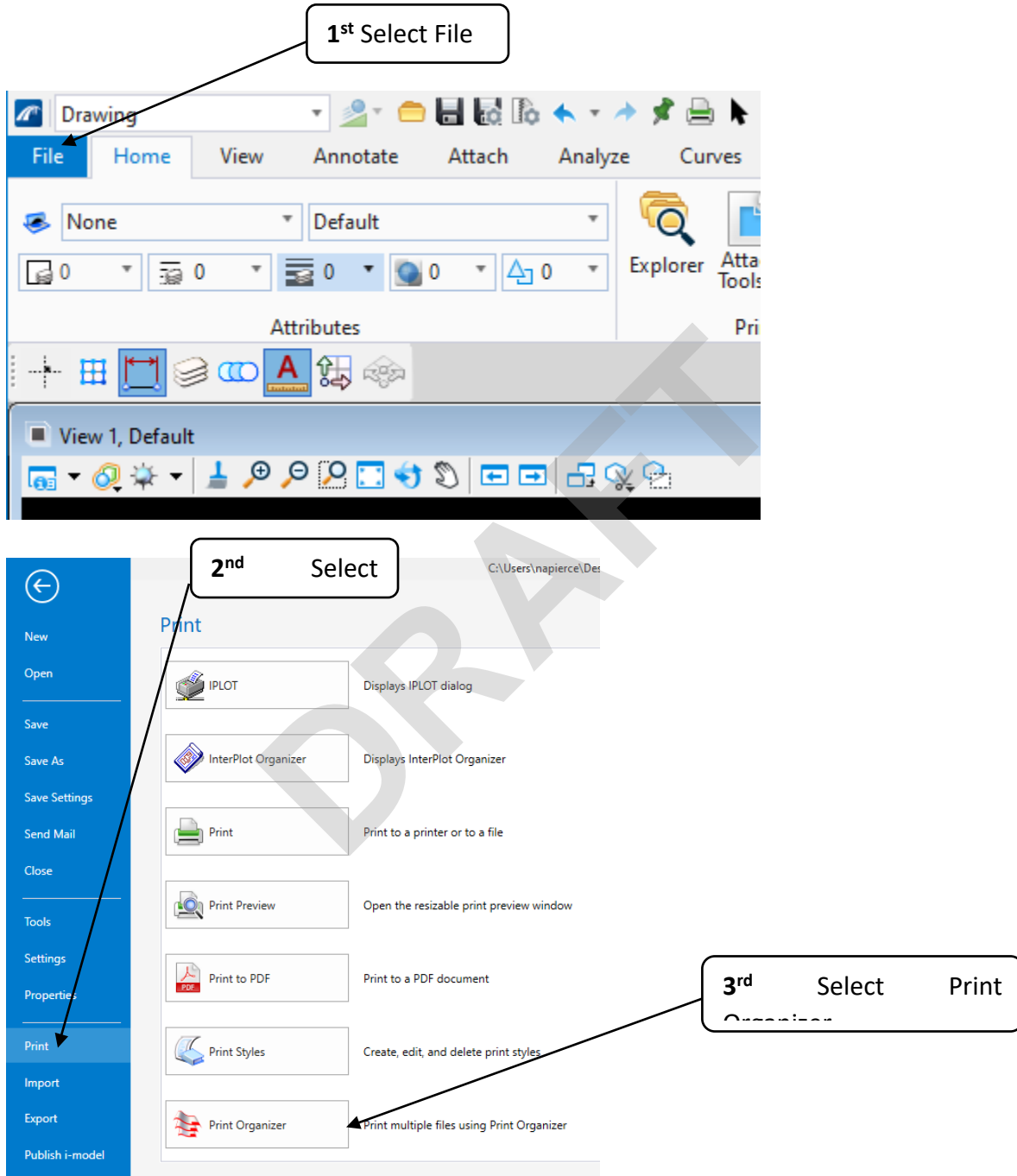

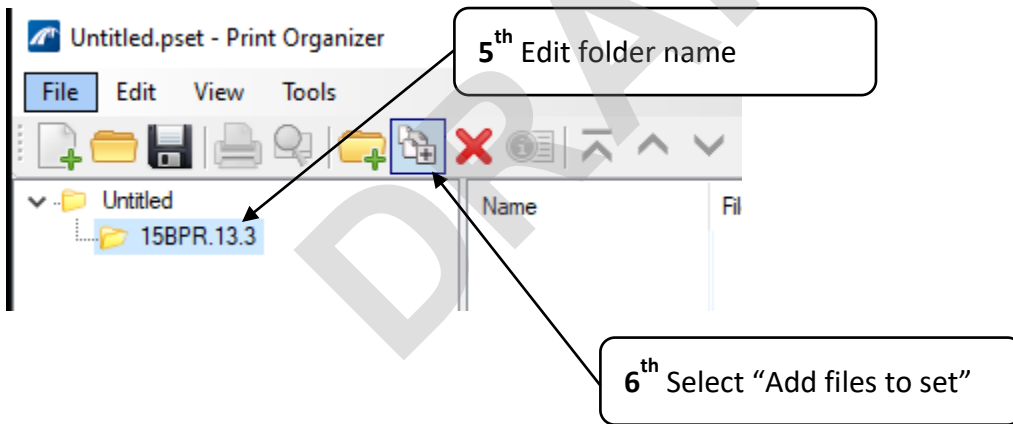
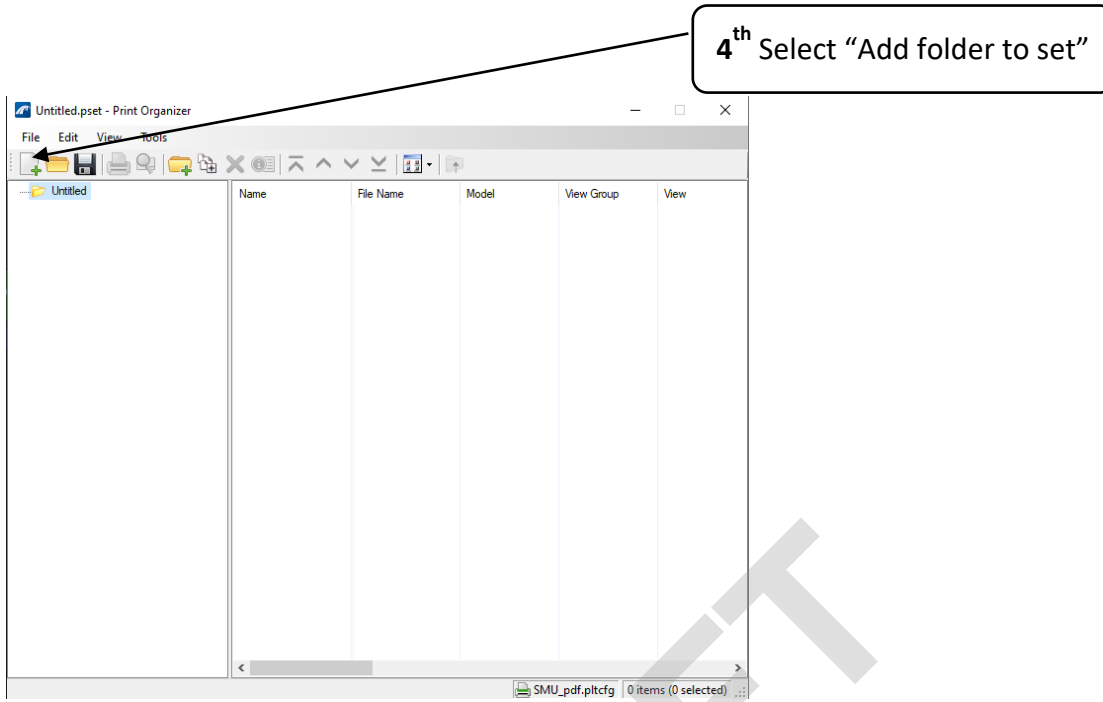

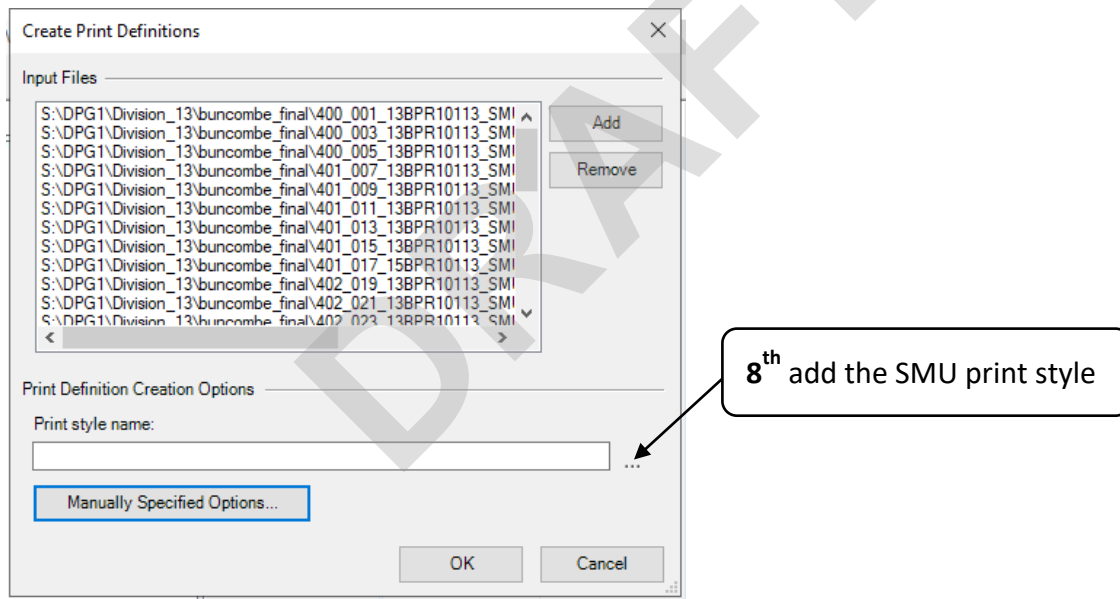
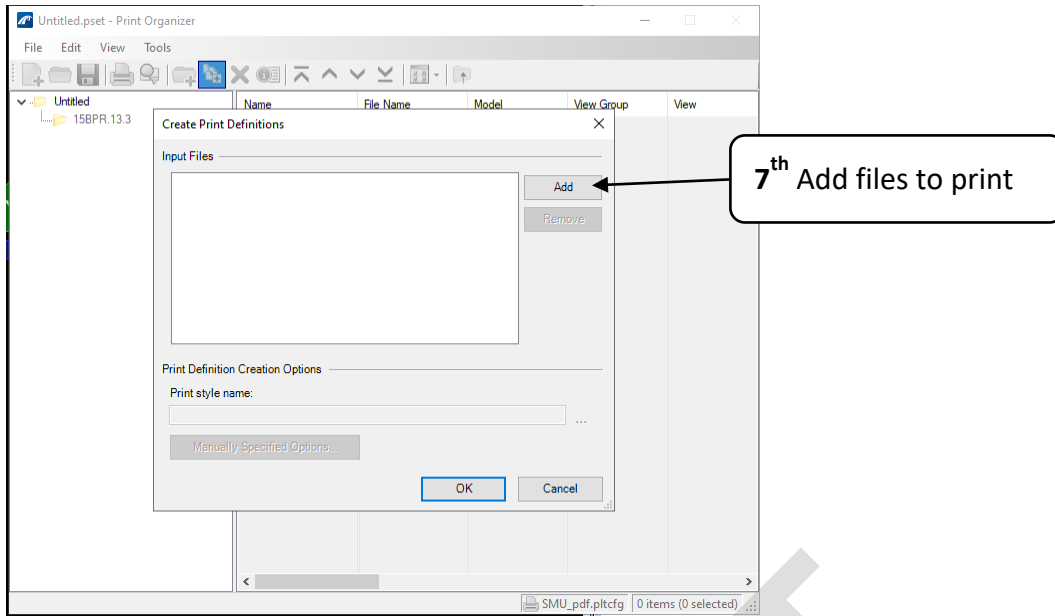

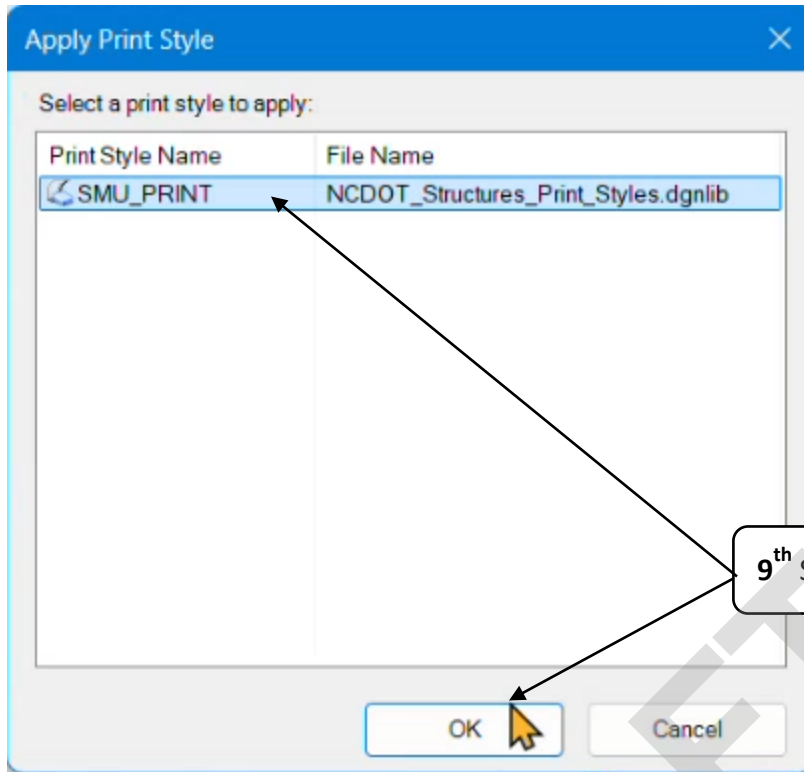

9th Select the SMU_PRINT and OK

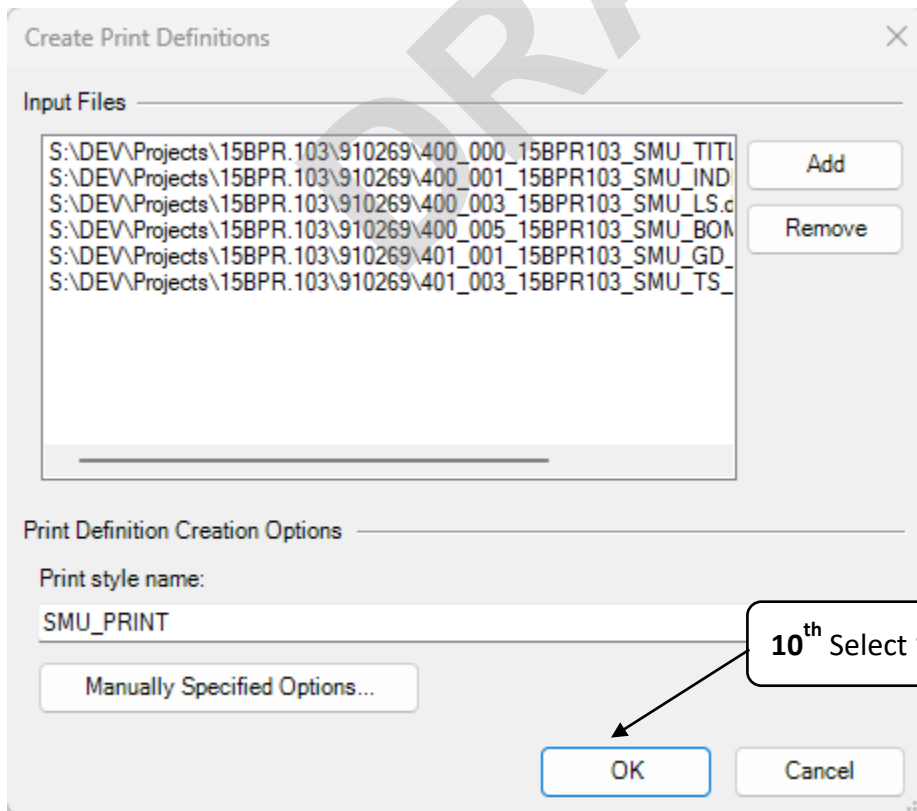

10th Select "OK"

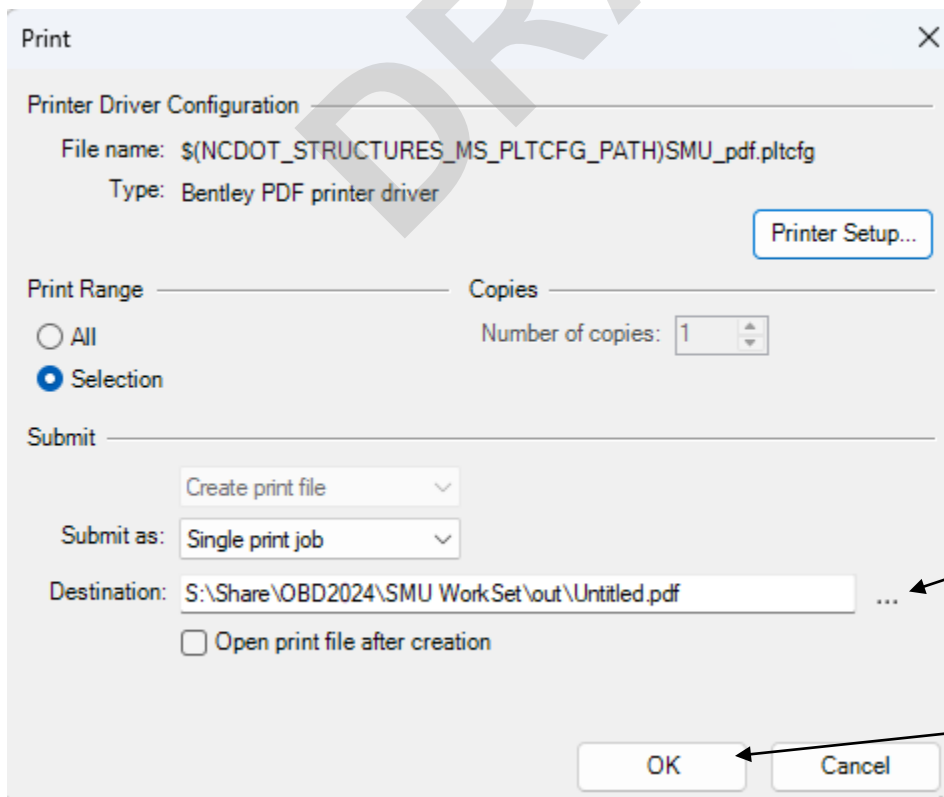
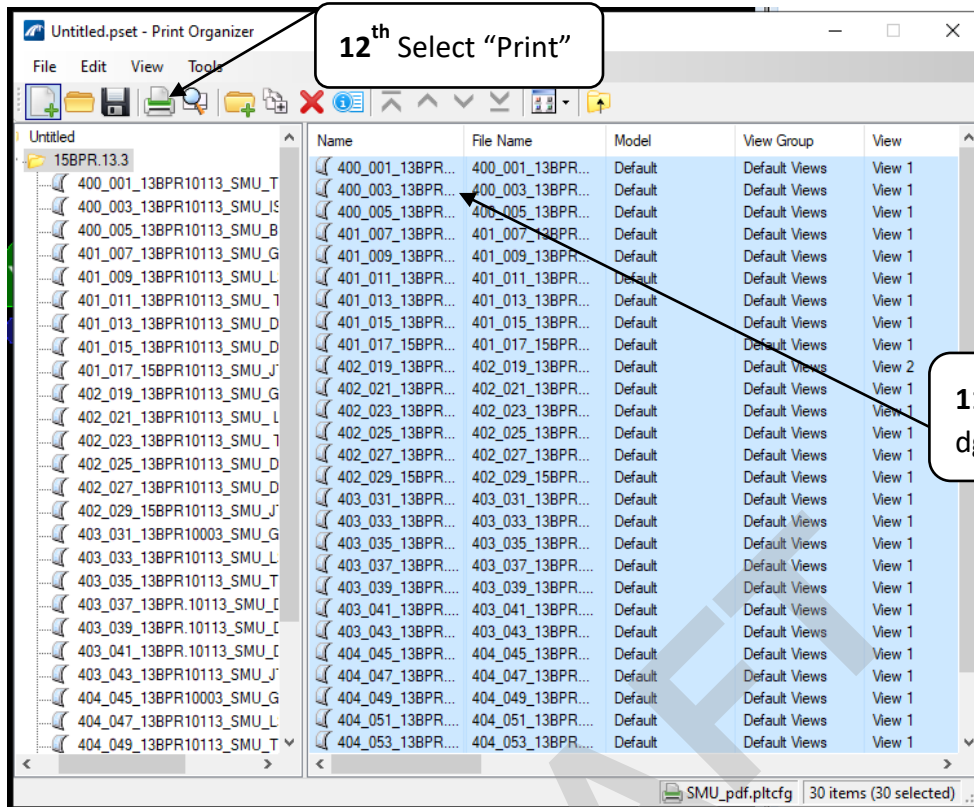

CONTENTS

Chapter 5.....5-1

5.1 General.....5-1

5.1.1 Simple Models.....5-1

5.1.2 Complex Models.....5-1

5.2 3D Model File Basics5-2

5.2.1 Bridge Templates.....5-2

5.2.2 File Workflow.....5-4

5.2.3 Referencing Files.....5-4

5.3 3D Model By Elements5-7

5.3.1 Adding A Bridge.....5-7

5.3.2 Adding Supportlines5-8

5.3.3 Adding the Deck.....5-10

5.3.4 Adding the Beam Layout.....5-11

5.3.5 Adding the Beams.....5-12

5.3.6 Adding Diaphragms.....5-13

5.3.7 Adding Bents5-14

5.3.8 Adding End Bents.....5-15

5.3.9 Adding Wing Walls5-16

5.3.10 Adding Bearings5-17

5.3.11 Adding Barrier Rails.....5-18

5.3.12 Adding Approach slabs.....5-20

5.4 3D Model With The Bridge Wizard5-21

5.5 Editing 3D Element Templates.....5-23

5.6 Editing A 3D Model5-25

5.6.1 Editing the Bridge Deck5-25

5.6.2 Editing the Beam Layout.....5-27

5.6.3 Editing the Beam Definitions5-28

5.6.4 Editing the End Bent.....5-29

5.6.5 Editing the Bent.....5-30

5.6.6 Editing Barrier Rails.....5-31

5.6.7 Editing Bearings5-32

5.6.8 Editing Wing Walls5-33

5.7 Item Types5-34

5.7.1 Attaching Item Types5-34

5.7.2 Detaching Item Types.....5-37

CHAPTER 5

3D MODEL CREATION

5.1 GENERAL

Prior to starting a 3D model, make sure the Level of Development is understood.

The final structure 3D model DGN organization needs to be determined early in the design process. The final model DGN file should display the final condition, but to reduce file sizes and risk of file corruption multiple structure DGN models may be required to get to the final condition.

When determining the number of 3D model DGNs required, consider what the construction sequence and final 2D plan sheets will look like.

5.1.1 Simple Models

Simple structure models can be created all in one DGN. These structures are often single to three span structures or culverts with off-site detours or new alignment structures not requiring any construction staging/phasing sequences. The Bridge Wizard is typically used to create these models.

5.1.2 Complex Models

Complex structure models, either due to construction sequencing and/or structure type and/or size, require the final model DGN to be a container file. Container files encompass referenced DGNs that make up parts of the final model. Depending on the complexity of the structure being modeled, the container file can be made up of the following types of individual DGN models.

Less Complex Model DGNs

- Construction staging sequences of proposed structure
- Sequencing existing structure removal used as on-site detour

More Complex Model DGNs

- Can include items listed under less complex model DGNs
- Bridge Elements:
 - Deck by Span
 - Girders by Span
 - End Bents
 - Bents

5.2 3D MODEL FILE BASICS

5.2.1 Bridge Templates

Copy the SMU Bridge Templates out of the workspace and into the project WorkSet folder to enable customization of templates to meet project specifics.

The SMU Bridge Templates are found under the NCDOT Workspace

Configuration_2024 > Organization-Civil > NCDOT > OpenBridge Modeler > Bridge Templates

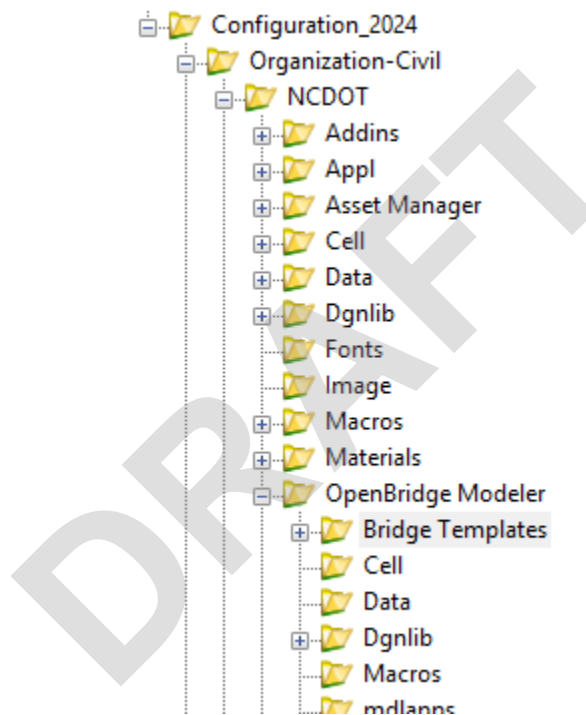

List Spatial

Name	Created	Description	File Size	File Update
Enter text here	Enter text here	Enter text here	Enter text here	Enter text here
Auxiliaries	6/30/2025 1:17:48 PM			
Bearings	6/30/2025 1:17:51 PM			
Functional Components	6/30/2025 1:17:54 PM			
ConnectionPlateLibrary.xml	6/30/2025 1:17:32 PM	ConnectionPlateLibrary.xml	10 KB	7/15/2025 8:59:18 A
ConnectorAngleLibrary.xml	7/15/2025 9:00:02 AM	ConnectorAngleLibrary.xml	4 KB	7/15/2025 9:00:03 A
CrossFrameLibrary.xml	6/30/2025 1:17:34 PM	CrossFrameLibrary.xml	139 KB	7/15/2025 8:59:38 A
default.lbclib	6/30/2025 1:17:35 PM	default.lbclib	163 KB	6/30/2025 1:17:36 P
ElementNumbers_NBl.xml		ElementNumbers_NBl.xml	1 KB	6/30/2025 1:17:37 P
ElementNumbers_State.xml		ElementNumbers_State.xml	1 KB	6/30/2025 1:17:38 P
FieldSpliceLibrary.xml		FieldSpliceLibrary.xml	3 KB	6/30/2025 1:17:39 P
MaterialLibrary.xml		MaterialLibrary.xml	38 KB	7/15/2025 9:00:24 A
PierLib.xml		PierLib.xml	517 KB	7/15/2025 9:00:44 A
ShearConnectorLibrary.xml		ShearConnectorLibrary.xml	5 KB	6/30/2025 1:17:43 P
StiffenerLibrary.xml		StiffenerLibrary.xml	1 KB	7/15/2025 9:01:04 A
templates.xml		templates.xml	3,272 KB	7/15/2025 9:01:38 A

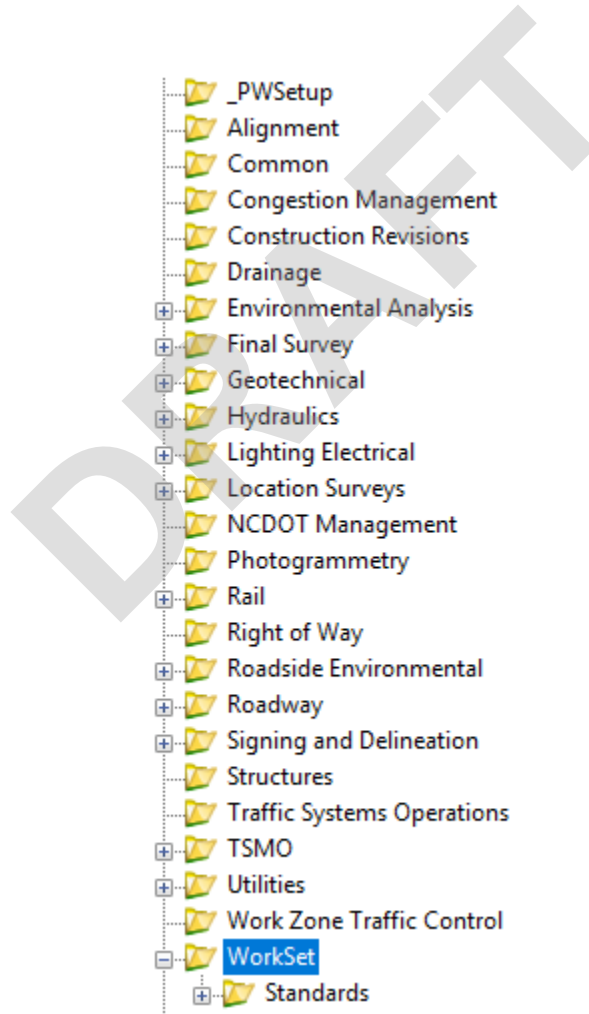

5.2.2 File Workflow

Create the model DGN file following the guidelines in Chapter 2. For 3D drawing creation, set OBD to the “OpenBridge Modeler” Workflow.

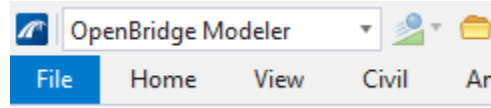

5.2.3 Referencing Files

Creating the 3D structure model starts with referencing the geometry (Alignment (rdy_alg.dgn), Alternates (rdy_alt.dgn) for NCDOT) and Terrain (rdy_etm.dgn for NCDOT) files. If you are using an older project, see Chapter 1 to incorporate those files.

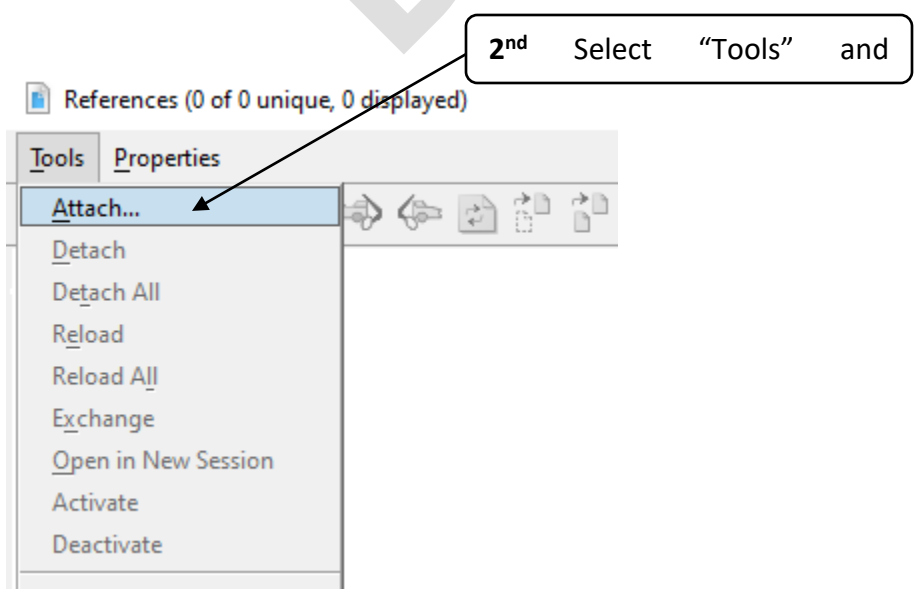
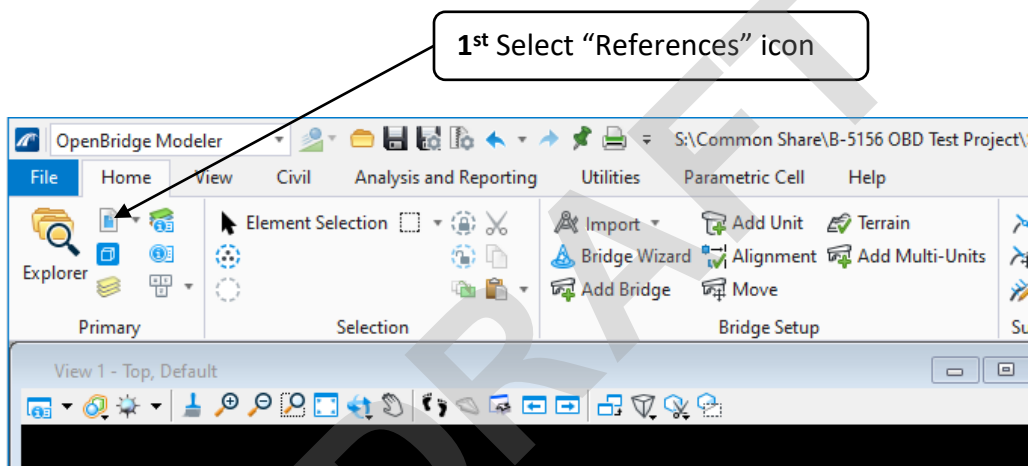

3rd Find and select the alignment and terrain files and open them

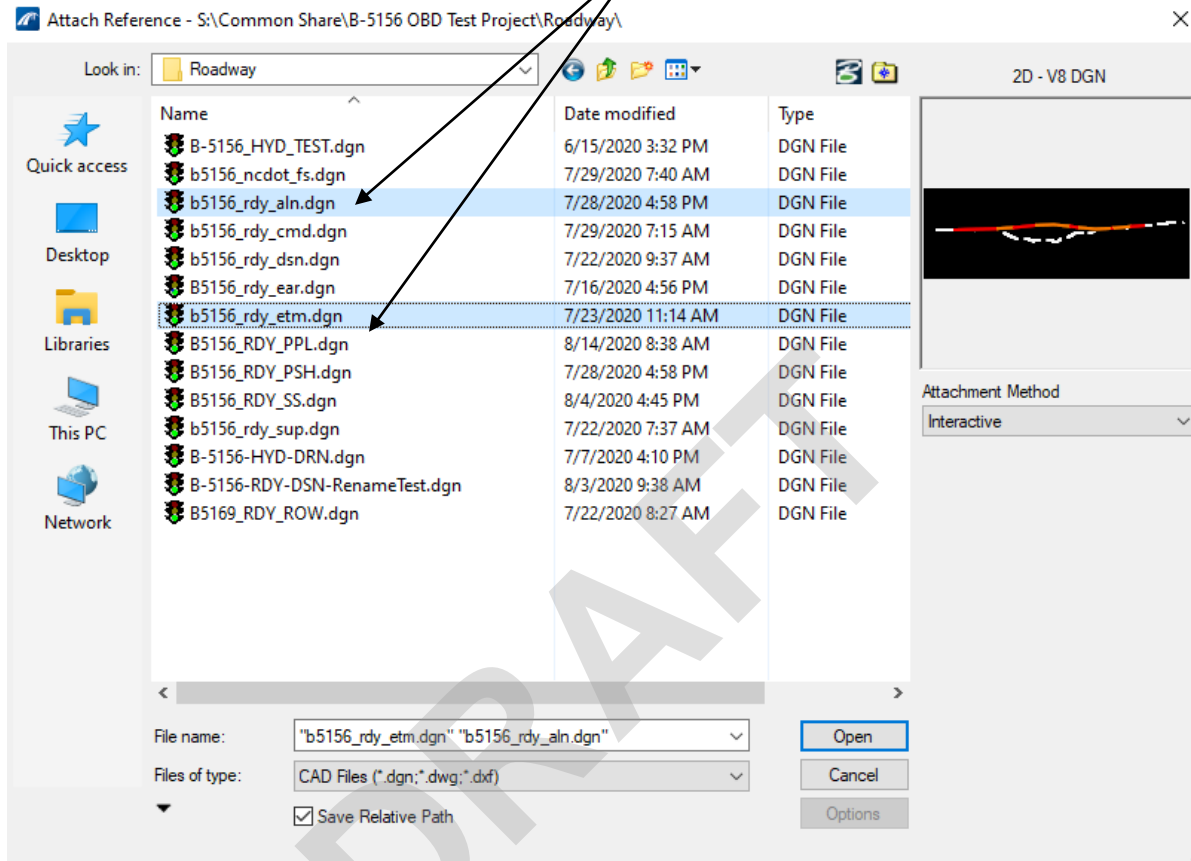

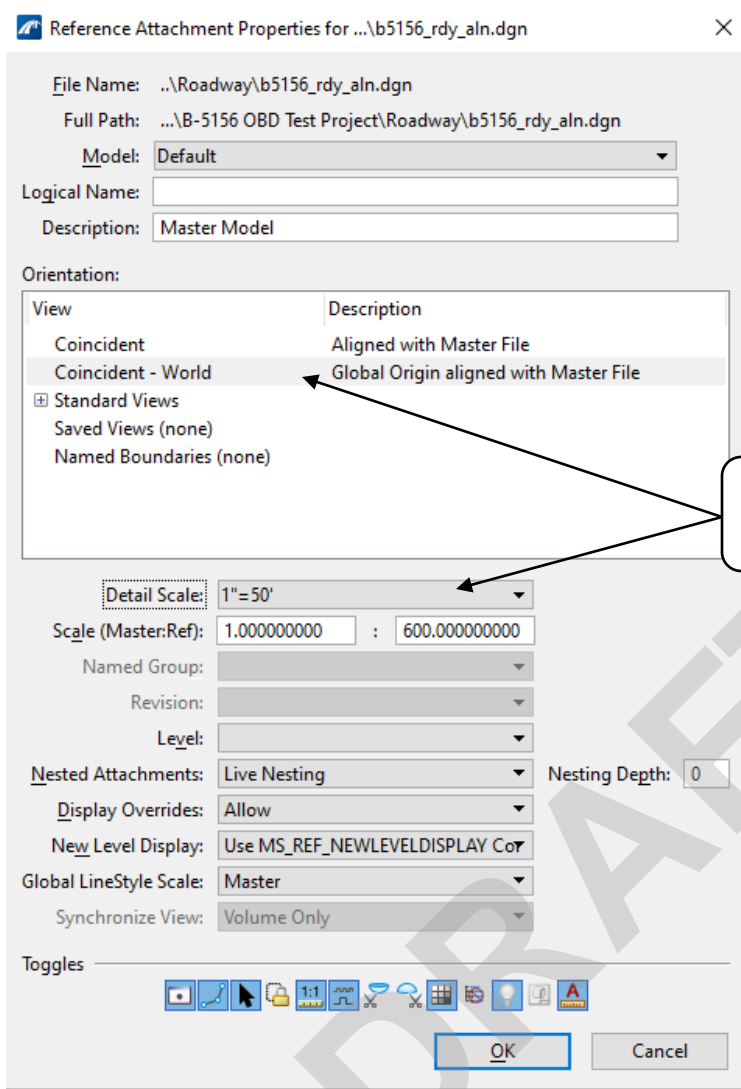

4th Set references to "Coincident-World" and scale to 1"=50'

5th Fit your view in both View 1 and View 2

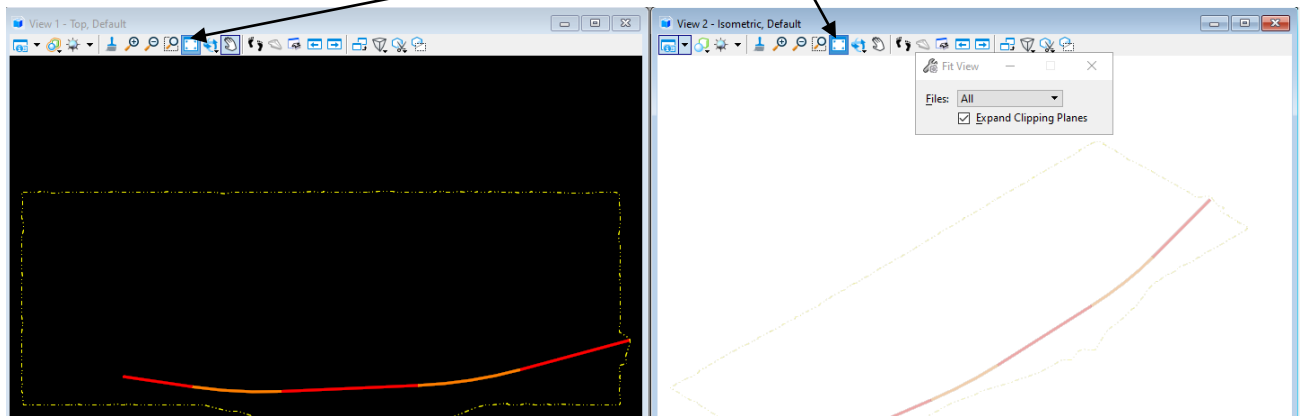

5.3 3D MODEL BY ELEMENTS

For 3D model the Design Model will be used to create the proposed or existing structure elements in a 3D view at full scale (1:1) in their correct geospatial locations. Create all elements at their true dimensions.

5.3.1 Adding A Bridge

After referencing the alignment and terrain files into the bridge model dgn, use the following steps to add a bridge. If multiple bridges are present on the project, create separate dgn files and reference the alignment for each structure.

1st Use the “Add Bridge” icon

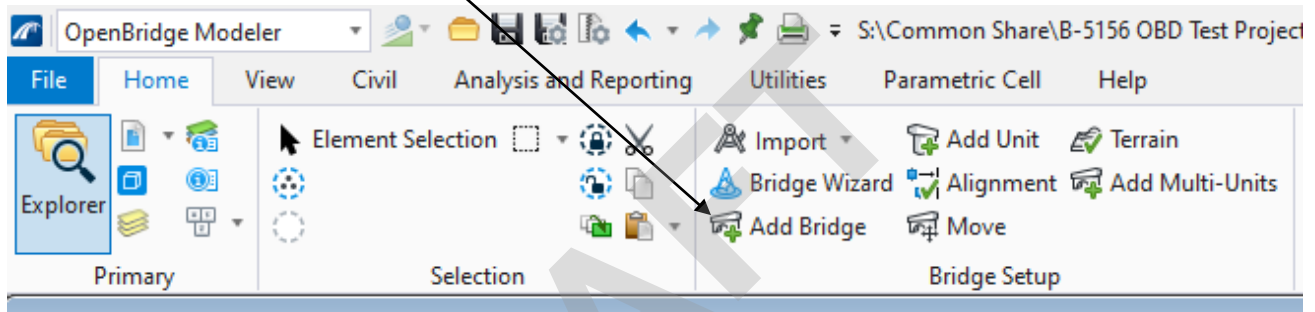

Add Bridge	
Description	910227
Requires Road Alignment	<input checked="" type="checkbox"/>
Use Road Alignment For Stationing	<input checked="" type="checkbox"/>
Unit	
Name	910227
Description	
Bridge Type	Beam Slab (P/S or RC Concrete Girders)
Feature	
Feature Definition	Bridge_decorations
Name Prefix	Bridge

2nd Fill in your Structure ID in the Description and Name boxes and select the bridge type and feature definitions from the drop downs

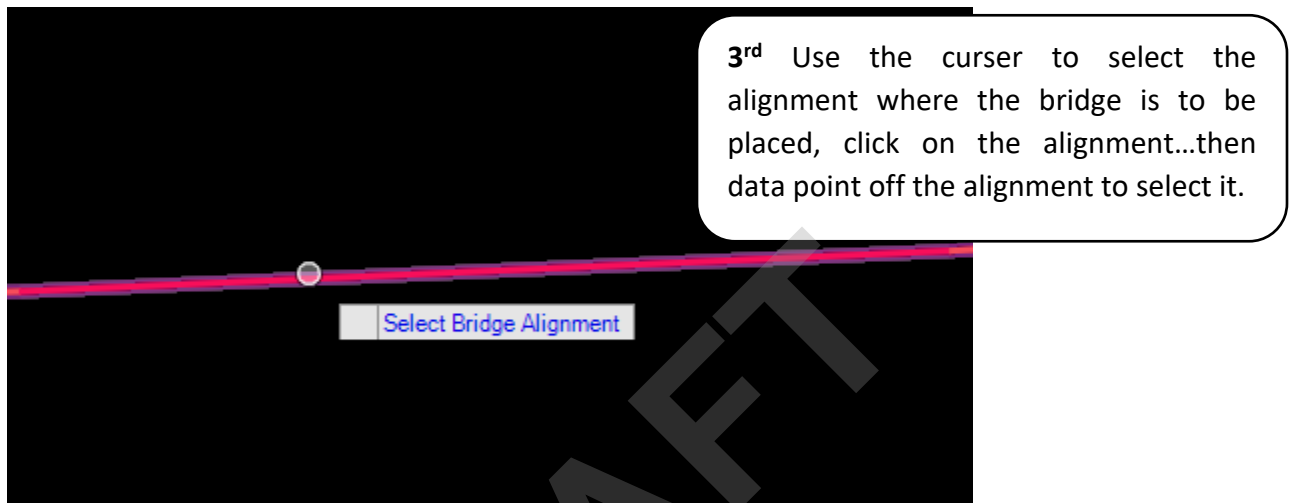

5.3.2 Adding Supportlines

After adding a bridge, use the following steps to add the end bent and bent supportlines. Supportlines will also need to be placed at the begin approach slab and end approach slab stations to add an approach slab deck.

1st Use the “Place Multi” SupportLine tool

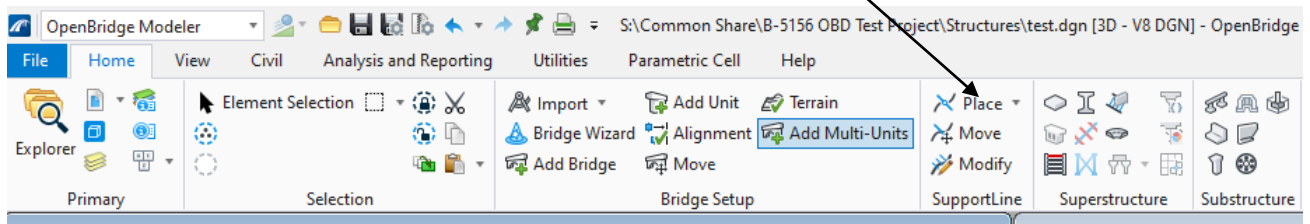

2nd Input your bridges' skew angle, start and end bridge stations, number of supportlines (note each end bent and bent has a supportline)

3rd Select the alignment near the start station, then near the end station.

Note: The "Length" in this box is the length of the SupportLine, so if you have a wide bridge make sure the length is long enough to project beyond your bridge model. Also OBD uses the skew angle as ahead and to the left as a negative value, unlike SMU that does ahead and to the right.

#	Name	Station	Angle	Span Length	Length
1	SupportLine1	23+44.5400	0°	0.000	100.000
2	SupportLine2	23+44.5400	0°	0.000	100.000
3	SupportLine3	23+44.5400	0°	0.000	100.000

4th Verify the stations, skew angles, and span lengths

5.3.3 Adding the Deck

After placing your supportlines, use the following steps to place the deck. There can be different deck templates used or multiple placements of the same template to create a bridge. An example of where multiple placements might be used is when including the approach slabs in your model you would place it from the begin approach slab supportline to the end bent 1 supportline and then the bridge deck would go from end bent 1 supportline to end bent 2 supportline.

1st Select the place the deck

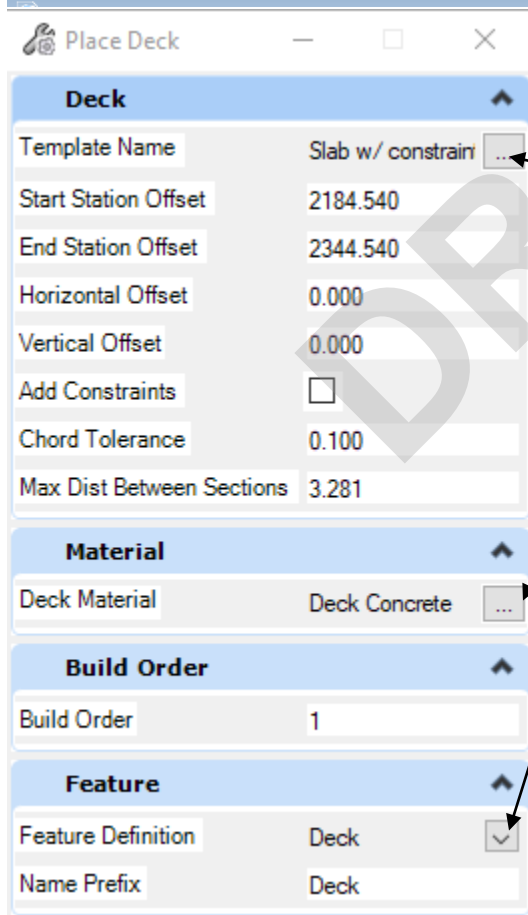
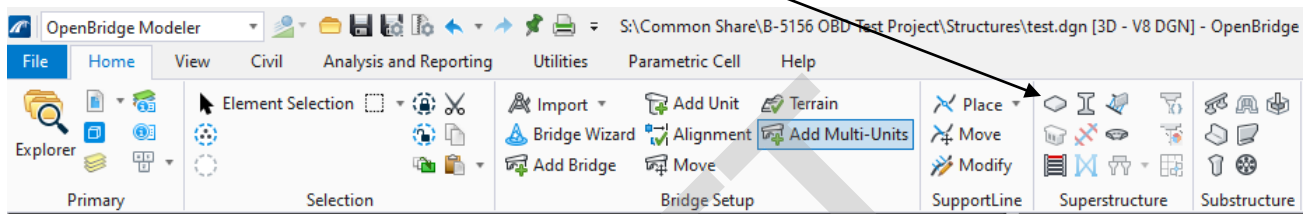

2nd Select the correct “Template” and “Feature Definition” for your bridge. Change the “Deck Material” to **Reinforced Concrete Deck Slab** for the bridge deck and **Bridge Approach Slabs** for the approach slabs to match NCDOT Pay Items

3rd Select the first support line, then the last support line for which the deck selected is to be placed

5.3.4 Adding the Beam Layout

After adding the deck, use the following steps to place the bridge’s beam layout. Be sure to follow the Design Manual for overhang and beam spacing requirements.

1st Select the “Place Beam Layout” tool

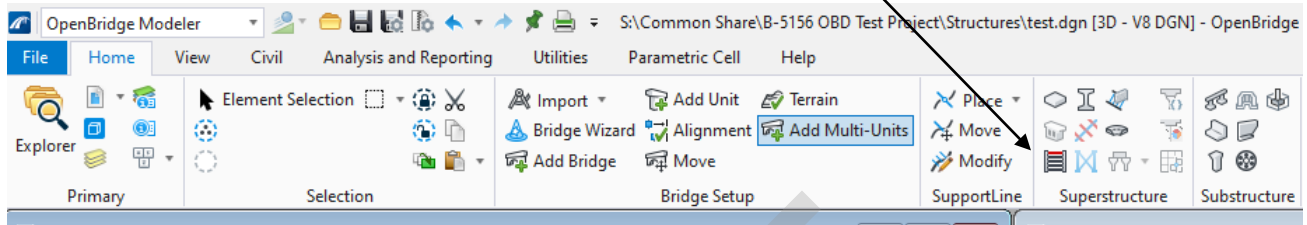

2nd Select the first support line, then the last support line of your bridge

3rd Enter beam spacings and bearing offsets from supportlines for each span

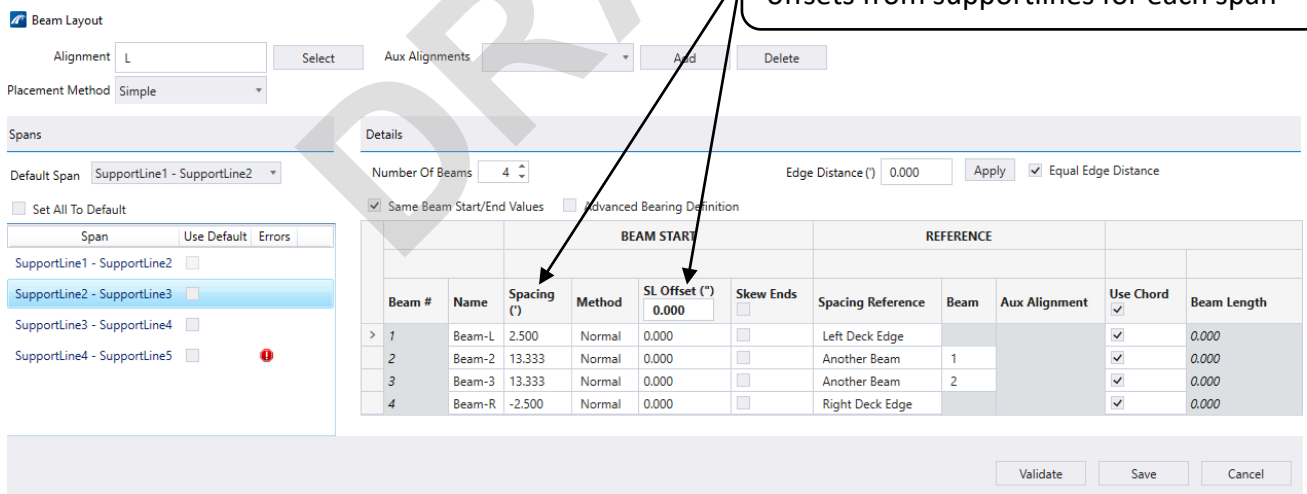

Note: the first and last beam spacing is the distance from the edge of deck and the last beam’s spacing is a negative value.

5.3.5 Adding the Beams

Once the beam layout is placed, use the following steps to attach the beam types.

1st Select the place beam tool

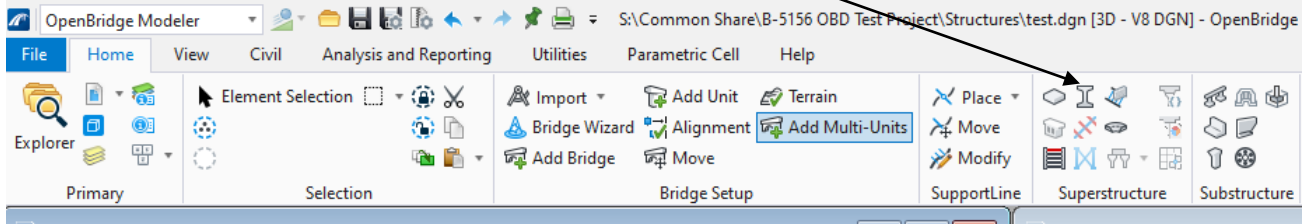

2nd Select the beam layout placed for your bridge

3rd Select the beam template and correct NCDOT Pay Item material for the beam template selected

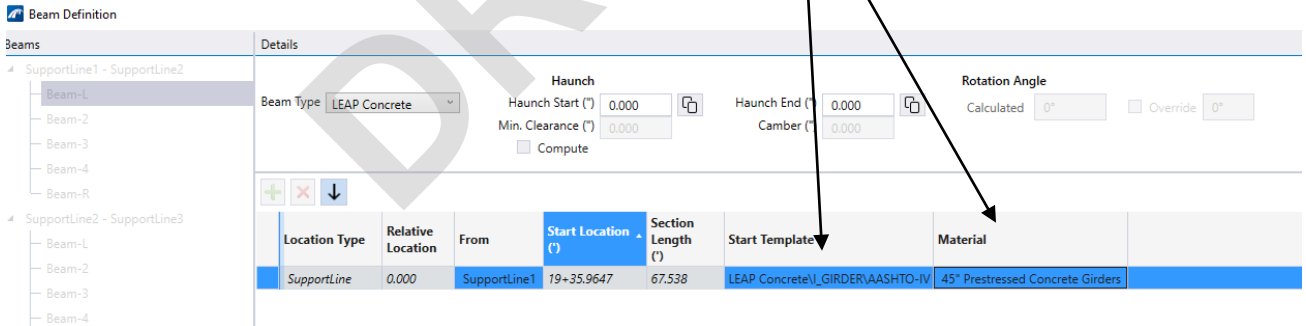

5.3.6 Adding Diaphragms

Once the beam layout is placed, use the following steps to attach the diaphragms.

1st Select the place diaphragm tool

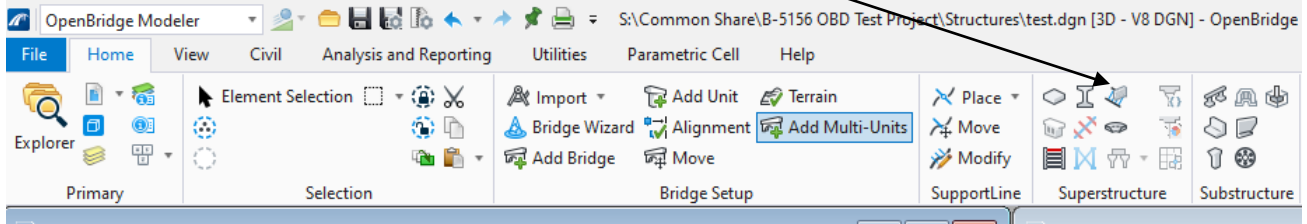

2nd Select the “+” symbol to add as many diaphragms as needed for the span and edit their locations

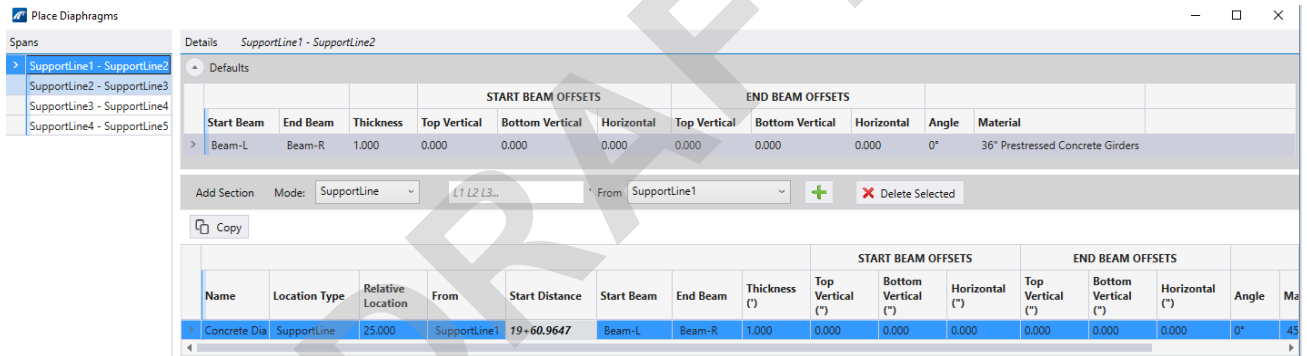

5.3.7 Adding Bents

Once the superstructure is placed, use the following steps to place the bents.

1st Select the place pier tool

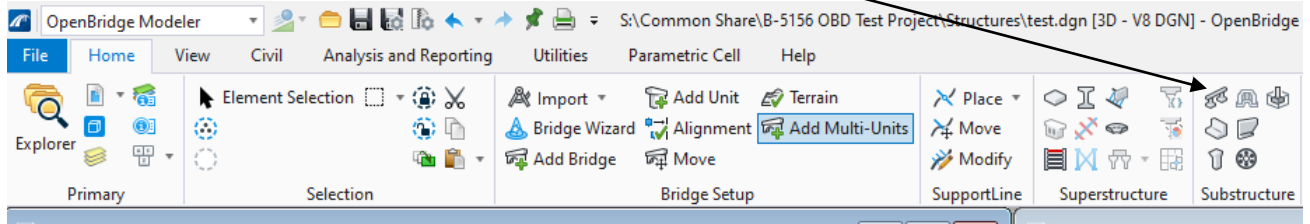

2nd Select the supportlines to place similar bents templates

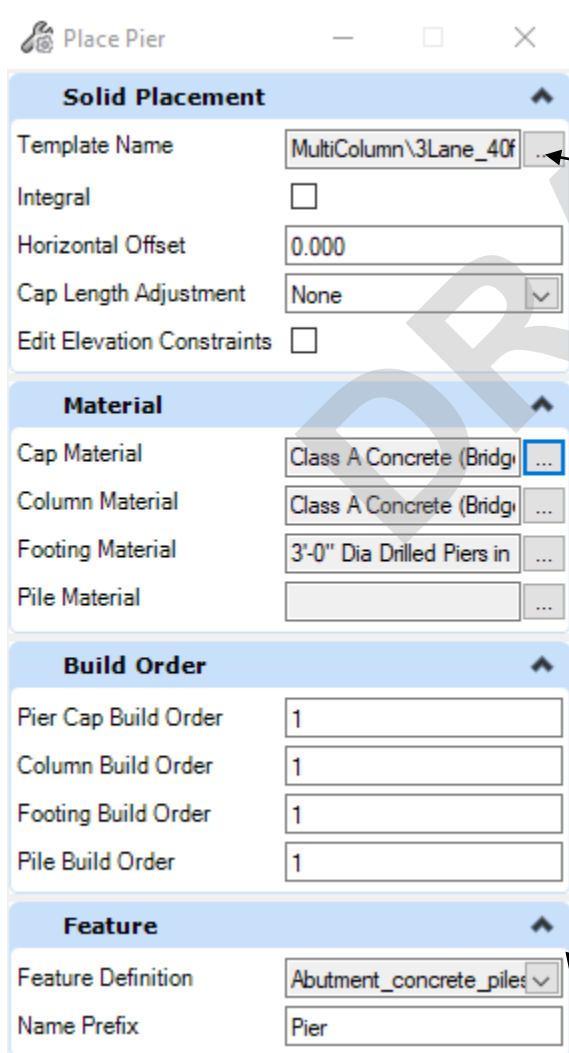

3rd Select the correct "Template" and "Feature Definition" for your bridge. Change the "Cap Material" to **Class A or AA** for the bridge deck and **Bent w/...** to match NCDOT Pay Items

5.3.8 Adding End Bents

To place the end bents, use the following steps:

1st Select the place abutment tool

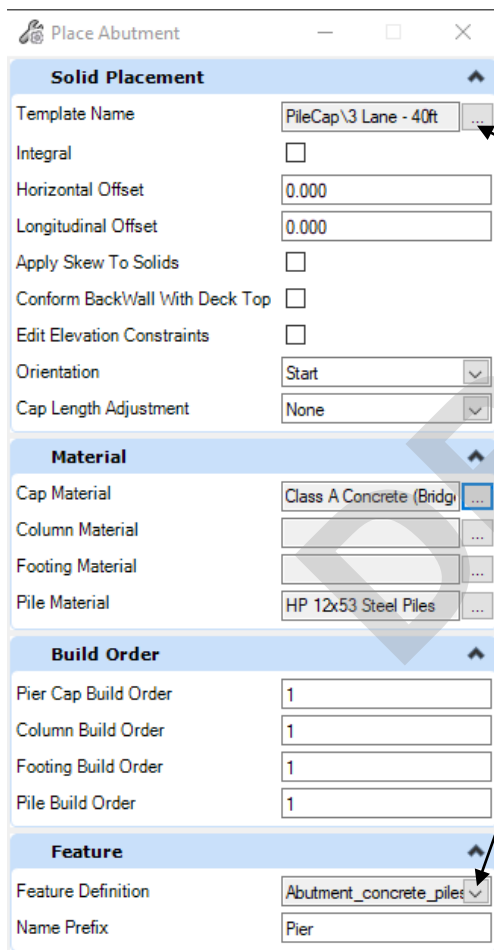
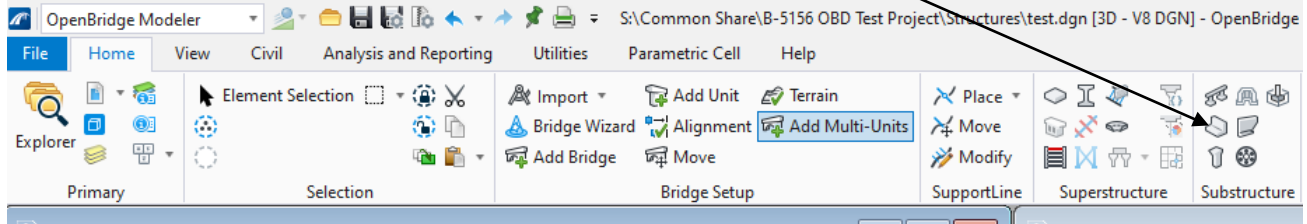

2nd Select the correct "Template" and "Feature Definition" for your bridge. Change the "Cap, Column, Footing and Pile Material" to **Class A, AA, etc.** and **End Bent w/...** to match NCDOT Pay Items

3rd Select the supportlines to place similar end bent templates

5.3.9 Adding Wing Walls

To place the wing walls, use the following tool:

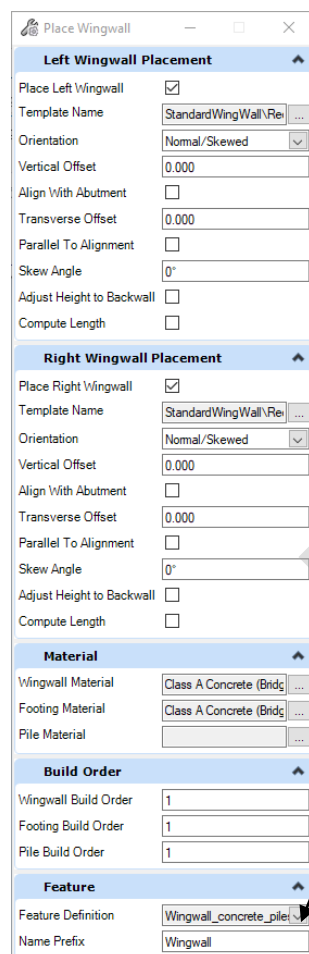
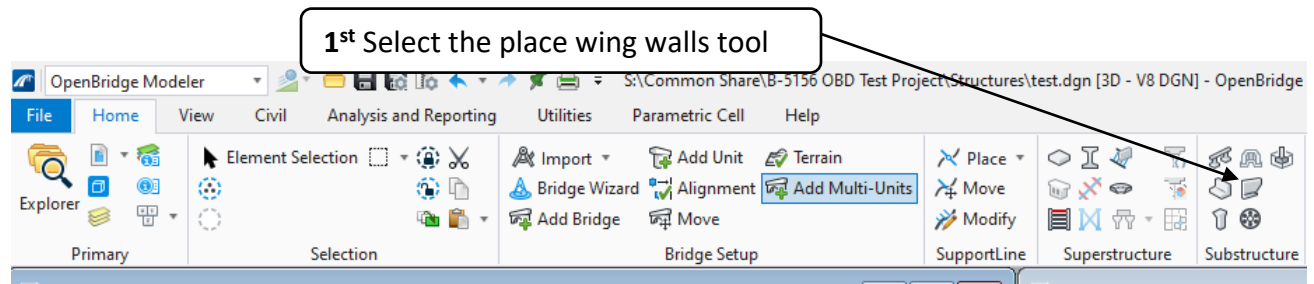

2nd Select the correct “Template” and “Feature Definition” for your bridge. Change the “Wingwall Material” to **Class A or AA** for the bridge deck and **Wingwall** for the approach slabs to match NCDOT Pay Items

Note wing walls can be placed at skews

3rd Select the end bents to place the wings

5.3.10 Adding Bearings

To place bearings, use the following tool:

1st Select the place bearings tool

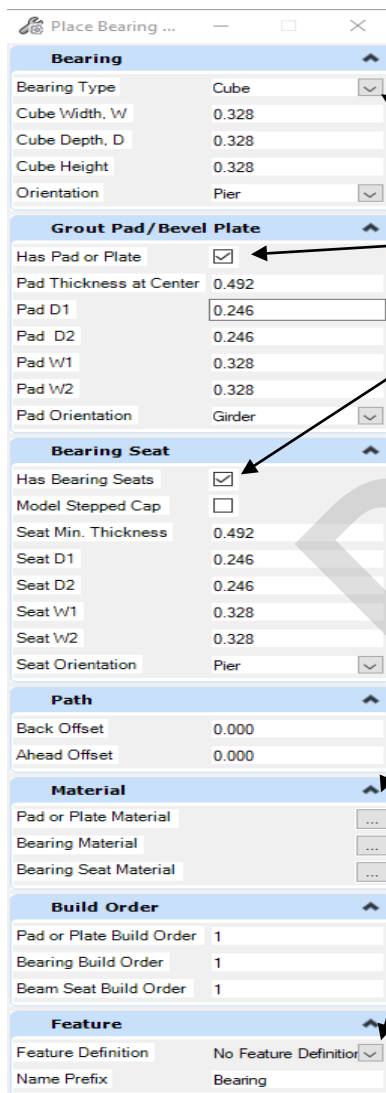
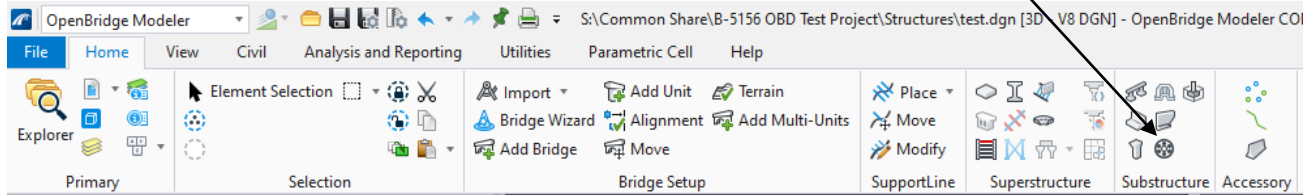

2nd Select the correct "Template" and "Feature Definition" for your bridge. Change the "Bearing Material" to **Elastomeric Bearing, Etc.** for the bridge deck and **Elastomeric Bearings** to match NCDOT Pay Items

5.3.11 Adding Barrier Rails

To place the barrier rails, use the following tool, once for the left rail and again for the right:

1st Select the place barriers tool

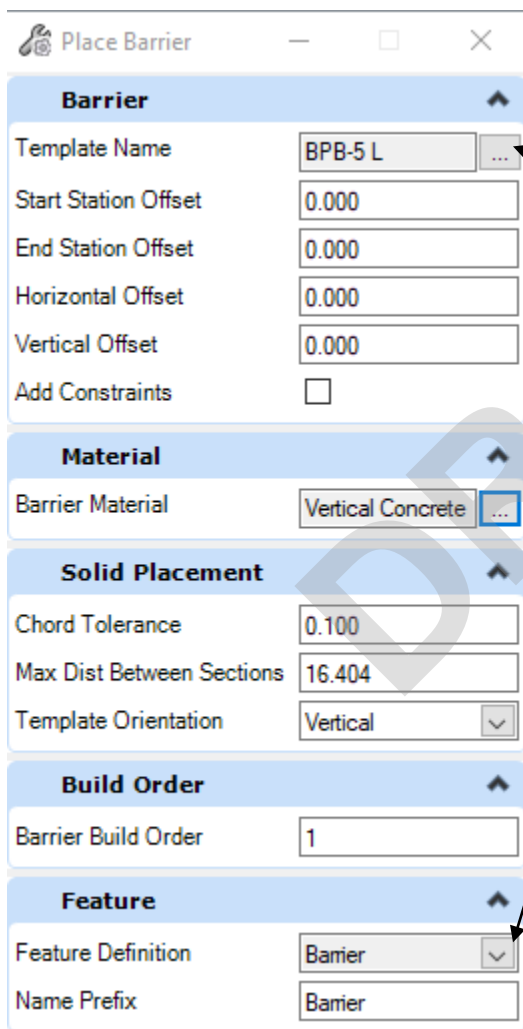
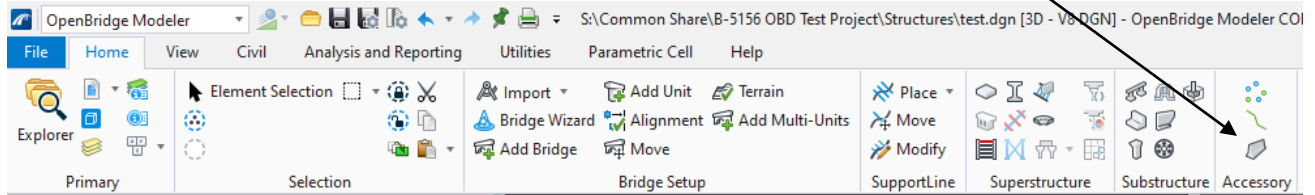

2nd Select the correct "Template" and "Feature Definition" for your bridge. Change the "Barrier Material" to **Concrete Barrier Rail, Etc.** for the bridge deck and **Concrete Barrier Rail** for the approach slabs to match NCDOT Pay Items

3rd Select the structure, then data point off

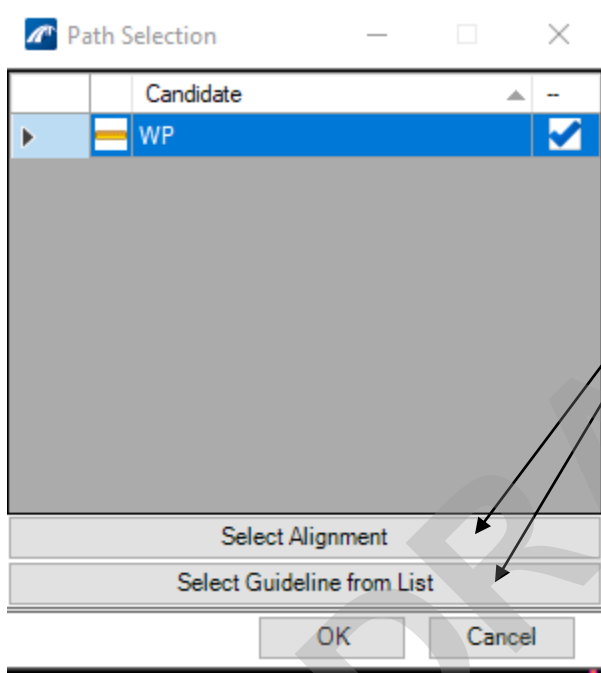

4th Click on “select alignment” then click on the alignment of the structure, then click on “select guideline from list” and select the point which to place the rail on the deck.....repeat for other rail

5.3.12 Adding Approach slabs

To place approach slabs in the model, add a single span bridge at the beginning of the bridge and the end of the bridge using the steps found in 6.1.2 through 6.1.4.

Enter “Begin/End App Slab” for bridge name, “RC Slab” for bridge type, select alignment, then follow the steps in section 6.1.2-6.1.4 and 6.1.12.

or using the “bridge wizard” as found in section 6.2

Enter “Begin/End App Slab” for bridge name, “RC Slab” for bridge type, select alignment, enter the start station, select deck template, enter the approach slab length for span, leave the abutment and pier templates as defaulted, select the appropriate left and right curbs for barrier templates

Note: once the bridge is placed with the bridge wizard, use the edit model techniques found in section 6.3 to DELETE the abutments placed in the model.

5.4 3D MODEL WITH THE BRIDGE WIZARD

A quick way to place a 3D bridge model is using the bridge wizard. Here are the steps.

1st Attach required reference files as covered in Section 6.1.1

2nd Click on the “Bridge Wizard” icon

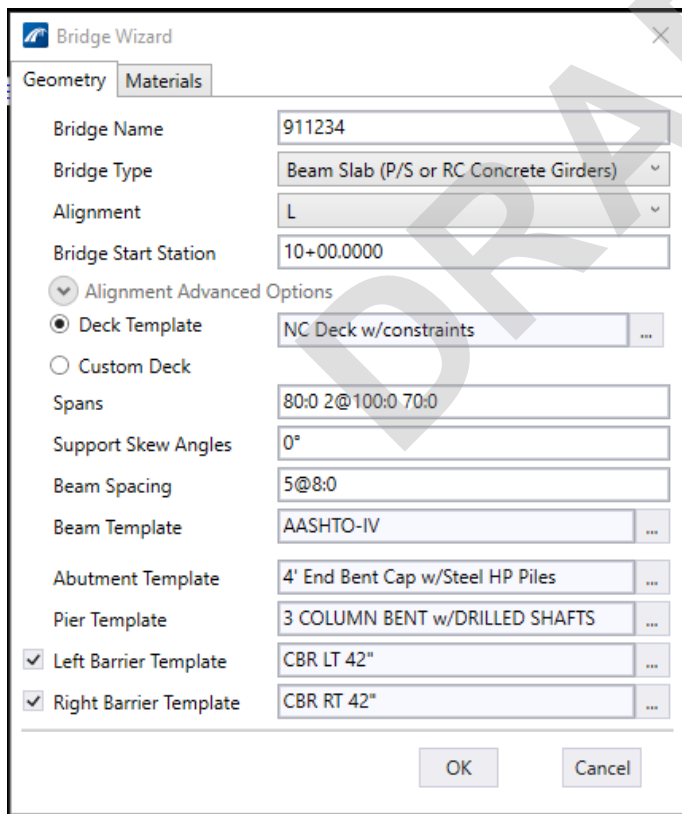
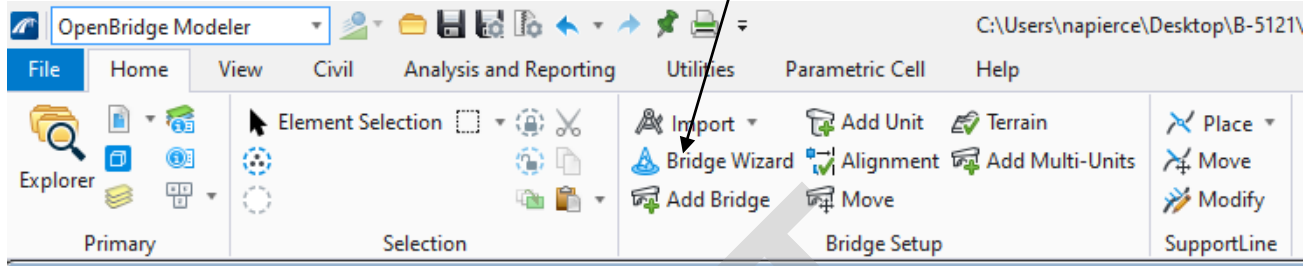

3rd Enter the bridge name, select the bridge type, select the alignment which the bridge is to be placed on, enter the bridge start station (work point 1 station), select the deck template to be used, enter the span arrangements, the skew, number and spacing of beams, and select the templates to be used for the beams, abutment, piers, left and right barrier rails

NOTE: Span lengths and Beam Spacing are entered as feet:inches, so 6'-3 1/2" beam spacing would be 6:3.5. Span lengths are also separated by a space between them.

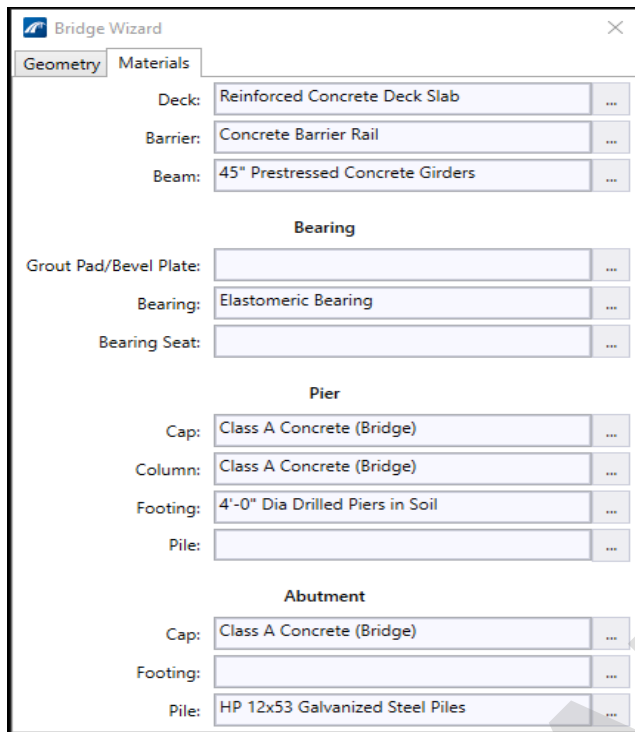

The screenshot shows the 'Materials' tab of the Bridge Wizard. It is organized into sections for different bridge components:

- Deck:** Reinforced Concrete Deck Slab
- Barrier:** Concrete Barrier Rail
- Beam:** 45" Prestressed Concrete Girders
- Bearing Section:**
 - Grout Pad/Bevel Plate: (empty)
 - Bearing: Elastomeric Bearing
 - Bearing Seat: (empty)
- Pier Section:**
 - Cap: Class A Concrete (Bridge)
 - Column: Class A Concrete (Bridge)
 - Footing: 4'-0" Dia Drilled Piers in Soil
 - Pile: (empty)
- Abutment Section:**
 - Cap: Class A Concrete (Bridge)
 - Footing: (empty)
 - Pile: HP 12x53 Galvanized Steel Piles

4th Select the "Materials" tab and select the pay items that match the elements. Once completed, go back the "Geometry" tab and click "OK."

The model should be built in your DGN, but bearings will need to be edited to display the correct type and dimensions and wing walls will still need to be added. The model will also need properties edited to display the correct material properties when reports are generated. If multiple Element Templates need to be changed, rather than editing each element, it may be easier to delete the existing 3D bridge model and start over with the Bridge Wizard. To quickly delete the existing bridge, use the Select All button to highlight the bridge and then hit Delete.

5.5 EDITING 3D ELEMENT TEMPLATES

If the Element Templates provided in the workspace are not adequate for the bridge being designed, the User may copy and edit the Element Templates before creating a structure as follows.

1st Go to the following folder SMU workspace in ProjectWise

Documents\Administration\WorkspaceGroups\NCDOTWorkspaces\Configuration_2023\Workspaces\DOT-USNorth Carolina\Roles\NCDOT_Structures\Standards\Bridge Templates\

2nd Copy all the Template “.xml” files

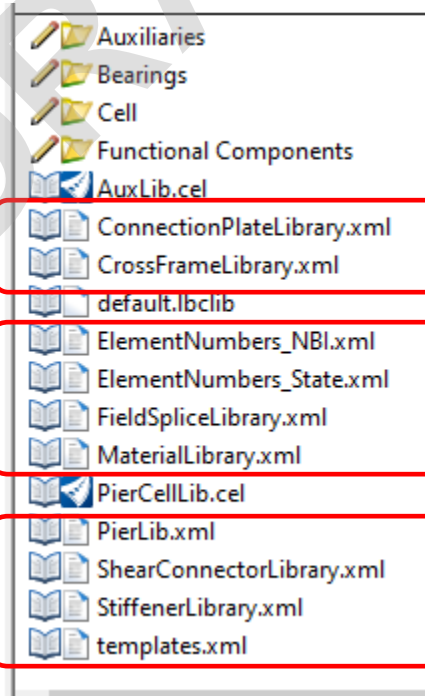

3rd Paste the Template “.xml” files in the project Bridge Templates folder

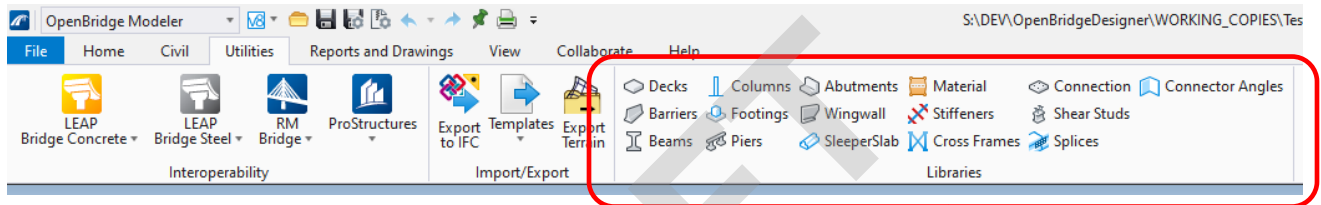
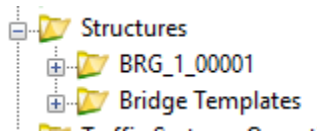

4th Edit the appropriate Templates using the Libraries tools

DRAFT

5.6 EDITING A 3D MODEL

Changes happen in bridge design, to edit an existing model use the steps for the elements below. For each element listed below, the following steps are required:

1st Select the element to be edited

2nd Click on the “properties” icon in the pop-up

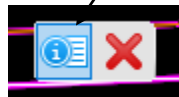

5.6.1 Editing the Bridge Deck

The bridge deck can be edited to change the template (super elevation left or right, or normal crown) or to edit the template constraints (left and right widths) and material type.

Start Station Offset	0.000'
End Station Offset	0.000'
Horizontal Offset	0.000'
Vertical Offset	0.000'
Template	SELECT to Edit ⋮
Chord Tolerance	0.328'
Max Dist Between Sec	3.281'
Variable Constraint	SELECT to Edit
Point Control	SELECT to Edit

Feature Definition	Deck
--------------------	------

Deck Build Order	1
------------------	---

Name	Deck
Description	
Template Name	Slab w/ constraints
State Element Number	12
NBI Element Number	12
SynclId	f1af4d7a-4815-452d-b7d0

Deck Material	Deck Concrete
---------------	---------------

To change the template, click here

To edit the deck widths, click here

To edit the feature definition, click here

Edit deck material to **NCDOT Pay Items**

To edit the deck widths, check "active" and then the "+" to edit begin and end width...do this for both left and/or right widths.

The screenshot shows the 'SingleDeckTemplateWindow' interface. The top part is a cross-section plot with 'Value' on the y-axis (ranging from -19.5 to -20.5) and 'Station Distance' on the x-axis (ranging from 23+11.5395 to 25+61.5395). Below the plot is the 'Variable Constraints' dialog box. The 'Variables' table is as follows:

Variable	Active	Default	Errors
LT_Slope_Lane1	<input type="checkbox"/>	0.020	
LT_Width_Lane1	<input checked="" type="checkbox"/>	-20.000	
Rotation By Angle*	<input type="checkbox"/>	0°	
Rotation By Slope*	<input type="checkbox"/>	0.000	
RT_Slope_Lane1	<input type="checkbox"/>	-0.020	
RT_Width_Lane1	<input type="checkbox"/>	20.000	
Thickness	<input type="checkbox"/>	-0.820	

The 'Add Section' area shows 'Mode: SupportLine' and a '+' button. Below it is a table with the following data:

Location Type	Relative Location	From	Start Distance	End Distance	Interval Length	Start Value	End Value	Transition
SupportLine	0.000	SupportLine1	23+11.5395	25+68.0388	256.499	-20.000	-20.000	Linear

The 'Start Value' and 'End Value' columns in the table are circled in red. The 'OK' and 'Cancel' buttons are at the bottom right.

5.6.2 Editing the Beam Layout

Beam Layout controls the number of beams, beam spacing and beam lengths

The screenshot shows the 'Beam Layout' dialog box. A callout box points to the 'BeamLayout' dropdown menu with the text 'To edit the beam layout, click here'. Another callout box points to the 'Number Of Beams' spinner control with the text 'Edit the number of beams here'. A third callout box points to the 'Span' list on the left with the text 'Select span to be edited'. A fourth callout box points to the 'Spacing' column in the table with the text 'Edit beam spacing and end of beams'.

Beam #	Name	Spacing (')	Method	SL Offset (")	Skew Ends	Spacing Reference	Beam	Aux Alignment	Use Chord	Beam Length
1	Beam-L	2.500	Normal	0.000	<input type="checkbox"/>	Left Deck Edge			<input checked="" type="checkbox"/>	64.125
2	Beam-2	8.750	Normal	0.000	<input type="checkbox"/>	Another Beam	1		<input checked="" type="checkbox"/>	64.125
3	Beam-3	8.750	Normal	0.000	<input type="checkbox"/>	Another Beam	2		<input checked="" type="checkbox"/>	64.125
4	Beam-4	8.750	Normal	0.000	<input type="checkbox"/>	Another Beam	3		<input checked="" type="checkbox"/>	64.125
5	Beam-R	-2.500	Normal	0.000	<input type="checkbox"/>	Right Deck Edge			<input checked="" type="checkbox"/>	64.125

Note: The first and last beam spacing is the distance from the outside edge of the deck and the last beam's spacing should be negative from the right outside edge of deck.

5.6.3 Editing the Beam Definitions

Editing the beam definitions allows changing beam types and material

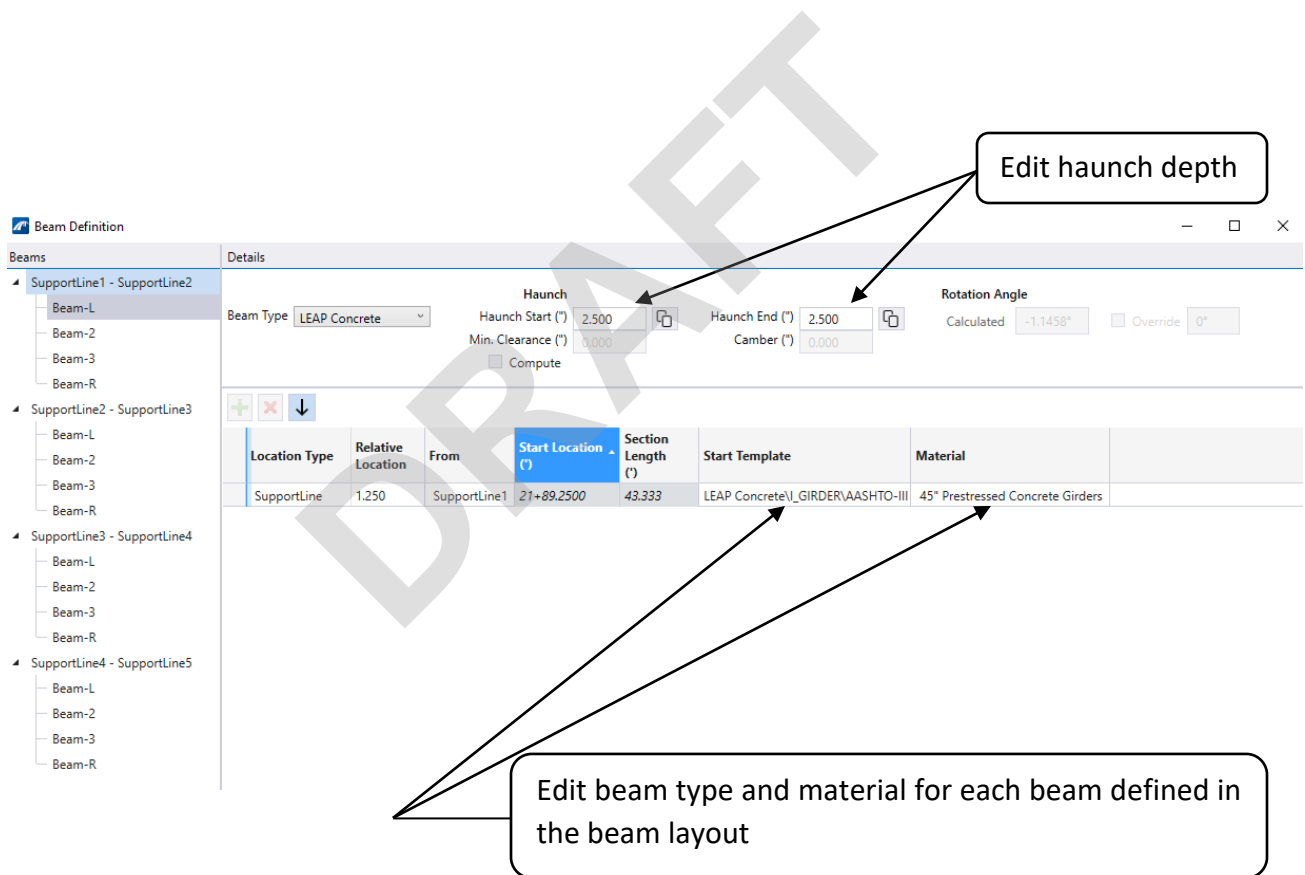
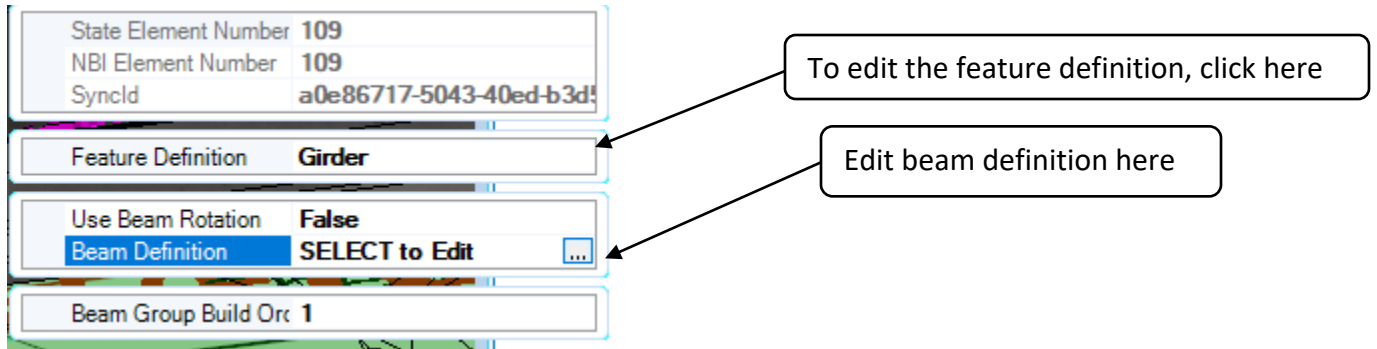

5.6.4 Editing the End Bent

End Bents properties can be edited for material types, elevation constraints and template properties such as cap dimensions, pile type/size and pattern.

The image shows a software interface for editing an abutment. It consists of several property tables and a 3D model view.

Abutment Properties Table:

Name	Abutment 1
Description	
Template Name	3 Lane - 40ft
State Element Number	219
NBI Element Number	219
Synclid	c2341a26-5a51-4fda-8194

Feature Definition: Abutment_concrete_piles

Build Order Table:

Pier Cap Build Order	1
Column Build Order	1
Footing Build Order	1
Pile Build Order	1

Material Properties Table:

Cap Material	Class A Concrete (Bridge)
Column Material	
Footing Material	
Pile Material	HP 12x53 Steel Piles

Elevation Constraints and Other Properties Table:

Elevation Constraints	SELECT to Edit
Substructure Template	SELECT to Edit
Apply Skew To Solids	False
Conform BackWall Width	True
BackWall Vertical Off:	0.000'
Integral	False
Horizontal Offset	0.000'
Longitudinal Offset	0.000'
Cap Length Adjustmer	By Deck
Orientation	Start

Substructure Template Properties Table:

SupportLine Alignment	Back of Abutment
Cap Length (")	41.250
Pile Cap Depth (")	48.000
Pile Cap Width (")	33.000
Back Wall Depth (")	60.000
Back Wall Width (")	33.000
Back Wall Horizontal Offset (")	0.000

3D Model View: Shows a 3D model of the abutment structure with a green cap and piles. A red line indicates the alignment. A callout 'WP' points to a specific part of the model.

Callouts:

- To edit the feature definition, click here (points to Feature Definition)
- Edit material types (points to Material Properties)
- Edit elevation constraints (points to Elevation Constraints)
- Edit template dimensions (points to Substructure Template)
- Edit cap and cheek wall dimensions as well as pile type and pattern (points to Substructure Template)

5.6.5 Editing the Bent

Bent properties can be edited for material types, elevation constraints and template properties, such as cap dimensions, column/pile type and size and pattern.

Name	Pier1
Description	
Template Name	3Lane_40ft
SyncId	87056895-6784-4028-92b...

To edit the feature definition, click here

Feature Definition	Abutment_concrete_piles
Pier Cap Build Order	1
Column Build Order	1
Footing Build Order	1
Pile Build Order	1

Edit material types

Cap Material	Class A Concrete (Bridge)
Column Material	Class A Concrete (Bridge)
Footing Material	3'-0" Dia Drilled Piers in S
Pile Material	

Edit elevation constraints

Elevation Constraints	SELECT to Edit
Substructure Template	SELECT to Edit
Integral	False
Horizontal Offset	0.000'
Cap Length Adjustmer	None

Edit template dimensions

Edit cap, cheek wall, columns, struts, footings, and piles properties such as dimensions, types and patterns

Substructure Template

Name: 3Lane_40ft Switch Template

Category: Default

Type: Multi Column

Analytical Type: Multi Column

Cap Cheek Walls Columns Struts Footings Piles

Type: Rectangle

Cap Length ('): 51.000

Cap Height ("): 60.000

Cap Width ("): 60.000

Edge: None

Add To Library OK Cancel

Display Mode: Isometric Front/Rear Left/Right Top/Bottom

5.6.6 Editing Barrier Rails

Barrier rail properties can be edited for start and end station offsets, template orientation, horizontal and vertical offsets, rail template, variable constraints, point control, point control path, feature definitions and material type.

The screenshot shows a software interface for editing barrier rail properties. The interface is divided into several sections:

- Properties Section:** Contains fields for Start Station Offset (0.000'), End Station Offset (0.000'), Template Orientation (Vertical), Horizontal Offset (0.000'), Vertical Offset (0.000'), Template (SELECT to Edit), Chord Tolerance (0.328'), Max Dist Between Sec (3.281'), Variable Constraint (SELECT to Edit), Point Control (SELECT to Edit), and Point Control Path (SELECT to Edit).
- Volume and Area Section:** Contains Volume (655.838 Cu.') and Surface Area (1802.640 Sq.).
- General Information Section:** Contains Name (Barrier1), Description (BU01), and Template Name (42" LT Vert Rail).
- Feature Definition Section:** Contains Feature Definition (No Feature Definition).
- Build Order Section:** Contains Build Order (1).
- Material Section:** Contains Barrier Material.

Callout boxes provide instructions for editing these properties:

- Edit start and end offsets if rails don't go full length of deck:** Points to Start Station Offset and End Station Offset.
- Edit offsets if rails are offset horizontally or vertically:** Points to Horizontal Offset and Vertical Offset.
- Change rail template:** Points to Template.
- Edit variable constraints:** Points to Variable Constraint.
- Edit point control and point control path if barrier rail is to be placed on a different location than default edge of deck:** Points to Point Control and Point Control Path.
- To edit the feature definition, click here:** Points to Feature Definition.
- Edit material type to NCDOT Pay:** Points to Barrier Material.

5.6.7 Editing Bearings

Bearing properties can be edited for cap steps, offsets from supportline, orientation, type, skew angle, dimensions, if it has a bridge seat or not and its dimensions, if it has a plate/pad and its dimensions and the material properties.

The screenshot shows a software interface for editing bearing properties. The main table contains the following data:

Model Stepped Cap	False
Back Offset	-0.750'
Ahead Offset	0.750'
Bearing Orientation	Pier
Bearing Type	Cube
Active Angle	0.0000°
Cube Width, W	2.000'
Cube Depth, D	1.000'
Cube Height	0.250'
Has Bearing Seats	True
Min. Thickness	0.250'
Seat D1	0.500'
Seat D2	0.500'
Seat W1	1.250'
Seat W2	1.250'
Orientation	Pier
Has Pad or Plate	False

Below the main table, there are three sections:

- Name:** BearingGroup 1
- Description:** BU01
- Feature Definition:** No Feature Definition
- Build Order:** Pad or Plate Build Ord 1, Bearing Build Order 1, Beam Seat Build Orde 1
- Material:** Pad or Plate Material, Bearing Material, Bearing Seat Material

Callout boxes provide instructions for editing various fields:

- Two boxes point to the Back Offset and Ahead Offset fields: "Edit offsets based on distance from the supportline".
- One box points to the Bearing Orientation, Bearing Type, and Active Angle fields: "Edit bearing orientation, type and dimensions".
- One box points to the Has Bearing Seats, Seat D1, Seat D2, Seat W1, and Seat W2 fields: "Edit bearing seats orientation, type and dimensions".
- One box points to the Feature Definition field: "To edit the feature definition, click here".
- One box points to the Material section: "Edit material types to NCDOT Pay".

5.6.8 Editing Wing Walls

Editing wing wall properties can be edited to change the vertical offset, alignment with abutment, transverse offset, skew angle, template and material properties.

The image shows a software interface for editing wing wall properties. It consists of several panels and a 3D model window.

Properties Panel (Top):

Synclid	aca83429-1d27-41e6-a63
Orientation	Normal/Skewed
Vertical Offset	0.000'
Align With Abutment	False
Transverse Offset	0.000'
Parallel To Alignment	False
Skew Angle	0.0000°
Adjust Height to Back	False
Compute Length	False
Wingwall Template	SELECT to Edit
Template Name	Rectangular

Feature Definition Panel (Middle):

Name	Wingwall
Feature Name	
Feature Definition	No Feature Definition

Build Order Panel (Bottom):

Wingwall Build Order	1
Footing Build Order	1
Pile Build Order	1

Material Panel (Bottom):

Wingwall Material	
Footing Material	
Pile Material	

Substructure Template Dialog (Bottom):

Name: Rectangular | Category: Default | Type: Wingwall

Cap | Piles

Height (')	10.000
Length (')	10.000
Top Thickness (")	14.000
Bottom Thickness (")	14.000
Top Horizontal Offset (')	0.000
Top Vertical Offset (')	0.000
Bottom Horizontal Offset (')	0.000
Bottom Vertical Offset (')	0.000
Additional Bottom Vertical Offset (')	0.000
Has Footing	<input type="checkbox"/>

3D Model Window (Right):

Display Mode: Isometric | Front/Rear | Left/Right | Top/Bottom

The 3D model shows a green rectangular wing wall structure.

Annotations:

- Arrow pointing to "SELECT to Edit" in the Properties Panel: Edit the Wing Wall Template
- Arrow pointing to the "Feature Definition" field: To edit the feature definition, click here
- Arrow pointing to the material fields: Edit material types to NCDOT Pay
- Arrow pointing to the "Piles" tab and dimensions in the Substructure Template dialog: Edit the wing wall dimensions and the piles

5.7 ITEM TYPES

Once the 3D model has been generated, Item Types should be attached to the various elements to convey metadata to be shared with various Stakeholders of the structure model.

5.7.1 Attaching Item Types

The following steps should be followed to attach Item Types:

Below is a view of the 3D model before any element is selected. There are no properties displayed until an element is selected.

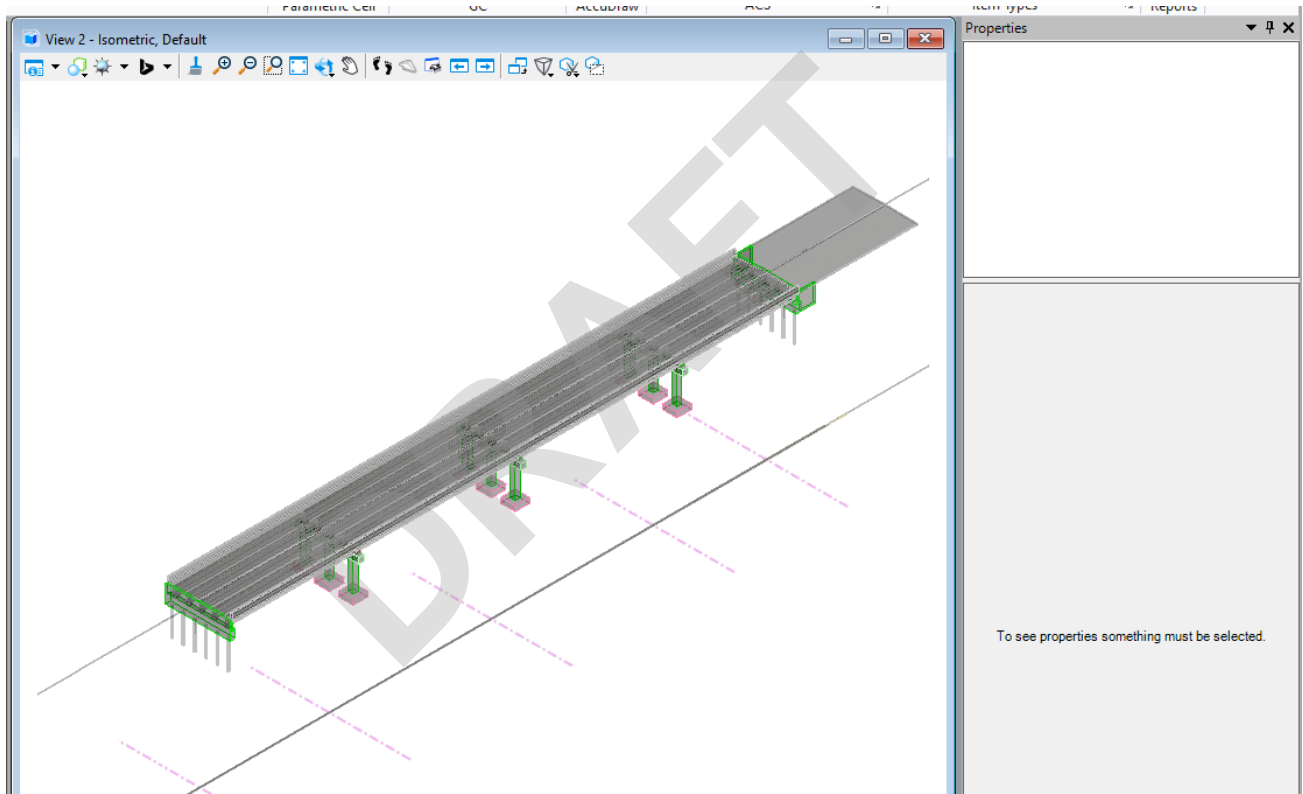

Under the OpenBridge Modeler workflow, go to Utilities tab and find Item Types Group on the ribbon.

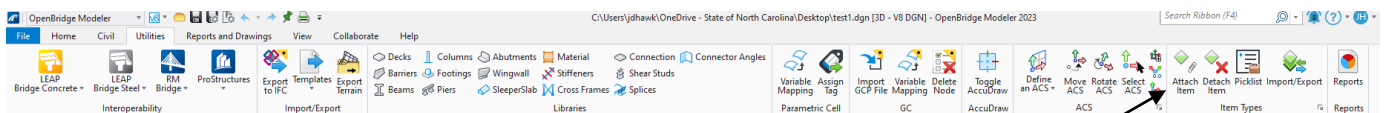

Click on the Attach Item icon

After clicking on the Attach Item icon, the Attach Item dialog box below will appear. Select the appropriate toggle for the Element to be attached.

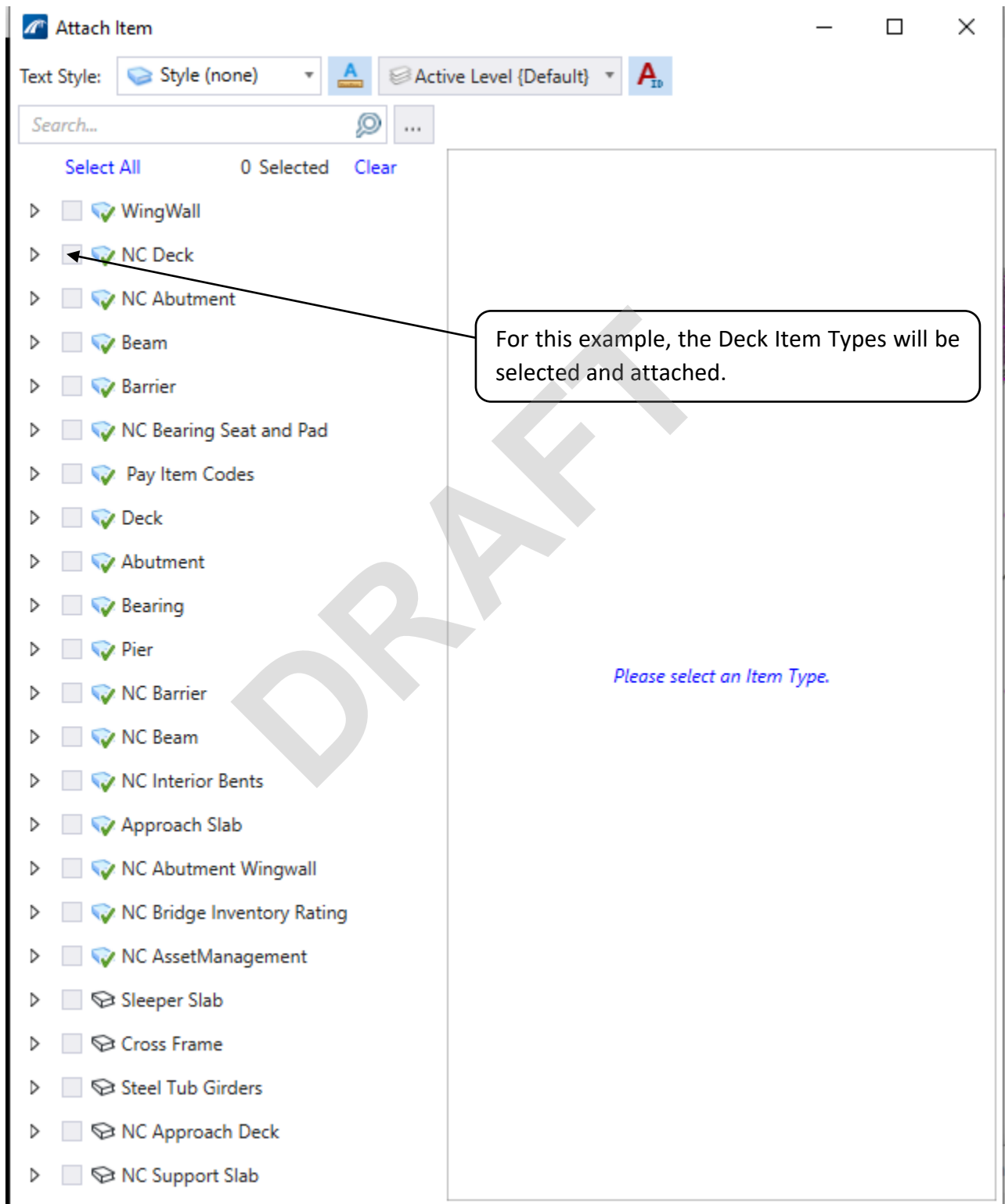

Use the Element Selection tool to select the Element to attach the Item Type to (eg the Deck for this example).

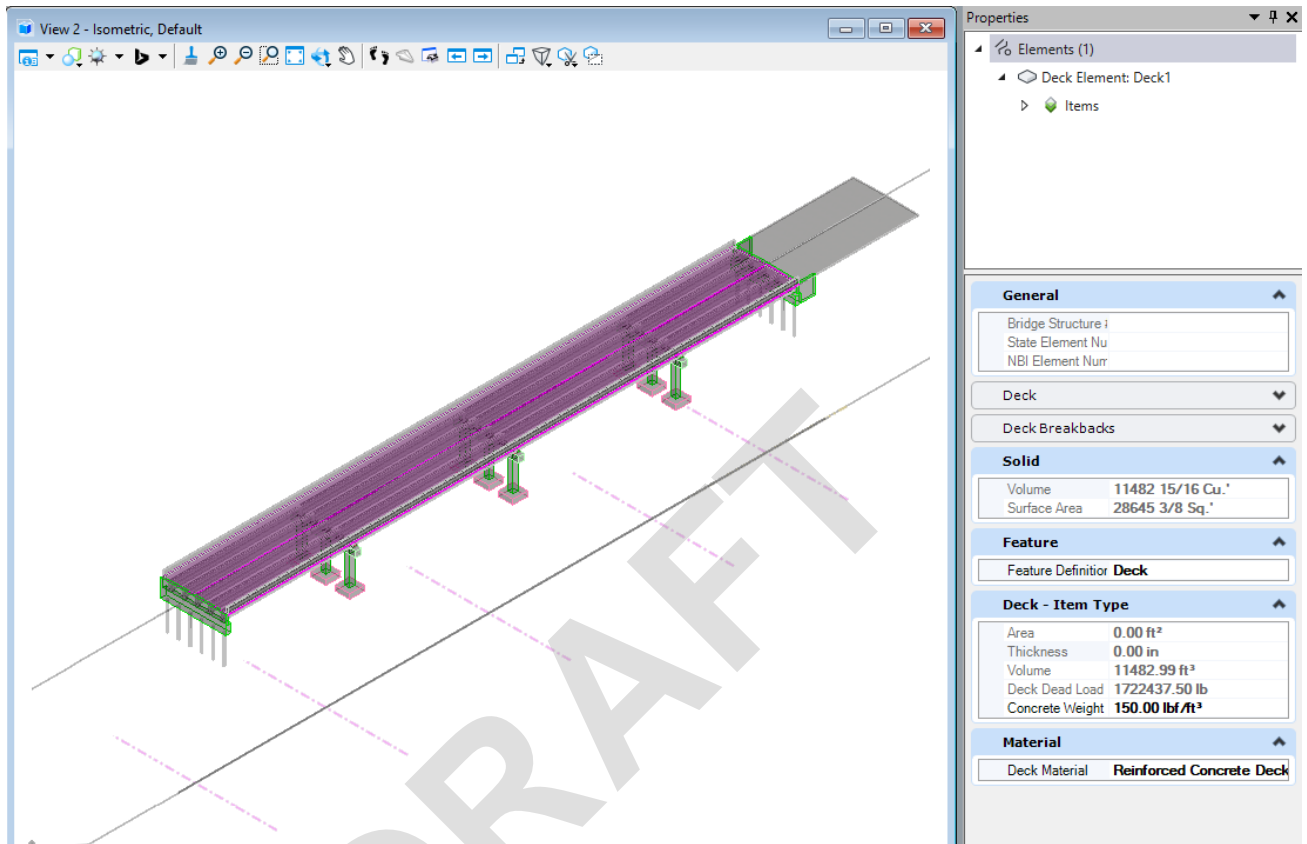

5.7.2 Detaching Item Types

The following steps should be followed to detach Item Types:

Under the OpenBridge Modeler workflow, go to Utilites tab and find Item Types Group on the ribbon.

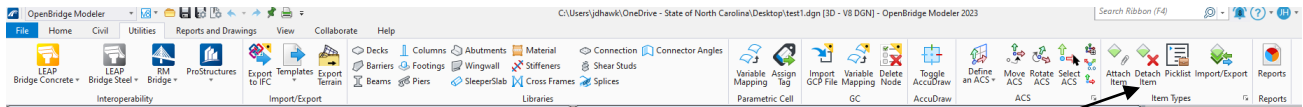

Click on the Detach Item icon

Select the Item Type from the drop down and select the element that you want to detach items from.

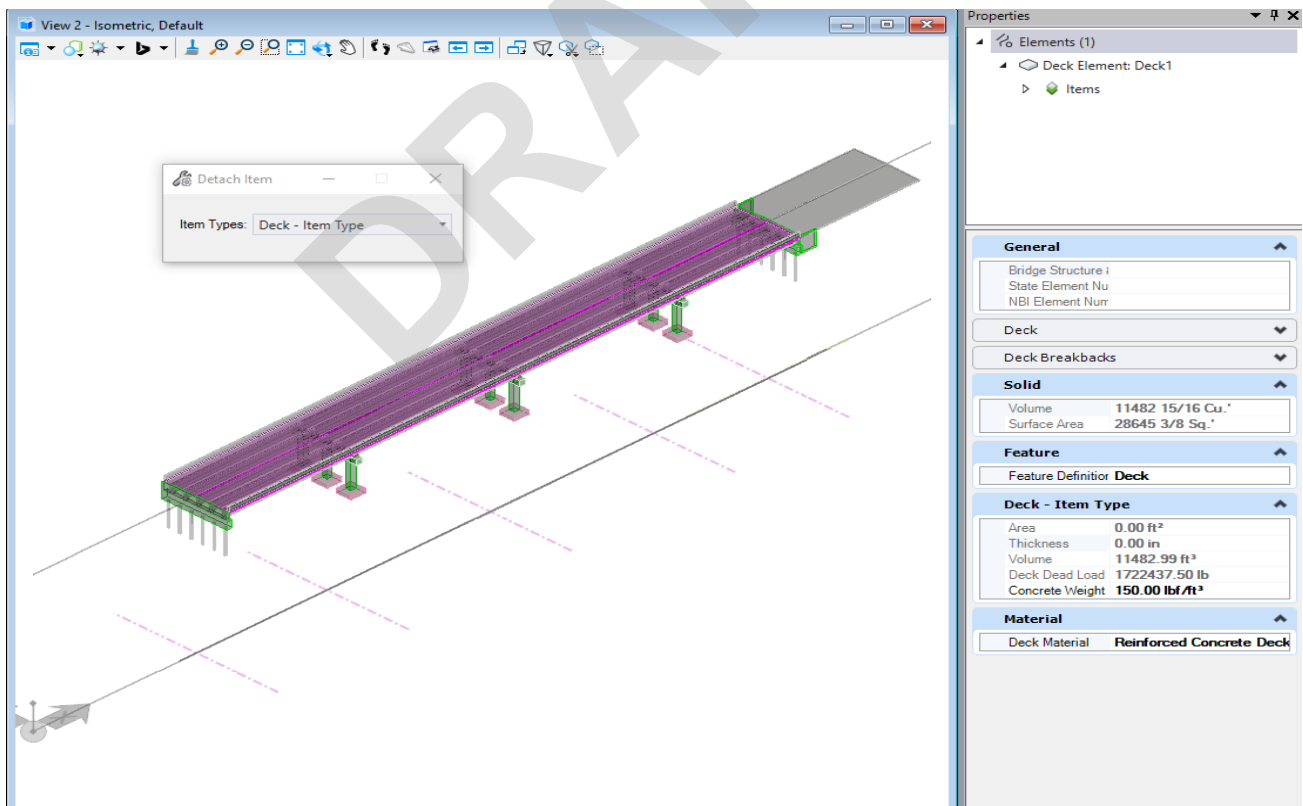

CONTENTS

Chapter 6.....6-1

6.1 Preliminary General Drawing.....6-1

6.1.1 Creating the 3D Model File6-1

6.1.1.1 Using ORD Alignment Files6-1

6.1.1.2 Using v8/GEOPAK Survey Files6-6

6.1.1.3 Using ORD Survey Files6-14

6.1.2 Creating A Plan and Profile Plan Sheet.....6-20

6.1.2.1 Creating the Plan View6-21

 Annotating The Plan View6-23

6.1.2.2 Creating the Profile View6-25

 Annotate the Profile Drawing Model6-27

6.2 General Drawing Sheets6-29

6.2.1 Foundation Layout Sheet.....6-29

6.2.2 Long Chord Layout Sheet.....6-32

6.2.3 Location Sketch/Total Bill of Material Sheet.....6-35

6.2.3.1 Location Sketch6-35

 Design.....6-35

 Preservation6-38

6.2.3.2 Total Bill of Material.....6-41

6.3 Geotechnical Foundation Table Sheets6-43

5.3.1 Foundation Tables Excel File6-43

5.3.2 Turn Off the Gridlines6-43

5.3.3 Link Spreadsheet Into The OBD File6-44

6.3.4 Setting Up the DGN.....6-44

5.3.5 Copy from The Excel File6-44

5.3.6 Paste From Clipboard Into OBD6-46

5.3.7 Properties of the Linked Tables in OBD6-49

5.3.8 Multiple Links6-51

5.3.9 Edit Link Properties.....6-52

CHAPTER 6

PRELIMINARY & GENERAL DRAWING CREATION

6.1 PRELIMINARY GENERAL DRAWING

Preliminary General Drawings (PGD) depict the basic layout of the proposed structure and involves the use reference files, such as the Hydraulics Units BSR file or the Roadway alignment file and cross section files. Reference Chapter 4 the *NCDOT Structures Management Design Manual* for guidance on requirements of a PGD.

Direct copying roadway, hydraulics and survey information out of OpenRoad DGNs will result in the OpenBridge DGNs becoming read only after exiting the file.

To generate the plan view and cross section drawings used in the PGD and General Drawing in OBD, a 3D Model DGN will need to be created using either proposed roadway alignment files or survey files of the existing alignment. This 3D Model DGN is where the 3D bridge model will be housed and used to create the 2D plan sheets from.

The following sections will walk through the process of setting up the 3D Model DGN with either a proposed roadway alignment files or survey files of an existing alignment to create a PGD and/or General Drawing.

6.1.1 Creating the 3D Model File

Creating a 3D Model DGN to house the structure 3D model and referenced roadway alignment and/or survey files is the first step in generating a preliminary general drawing and/or general drawings. This DGN Model will be referenced into the PGDs and GDs.

****Note:** In future workflows where a 3D structure model is required, this DGN is where the structure model will be created and referenced to create 2D plans.

6.1.1.1 Using ORD Alignment Files

The following steps use an ORD Alignment file to produce a 3D model.

Step 1

Once the structure Model DGN has been created, go to the **Home tab > Primary ribbon > Attach Tools > References** find and attach the proposed Alignment (ALG), Final Survey (FS) and ECTM files for the project as references.

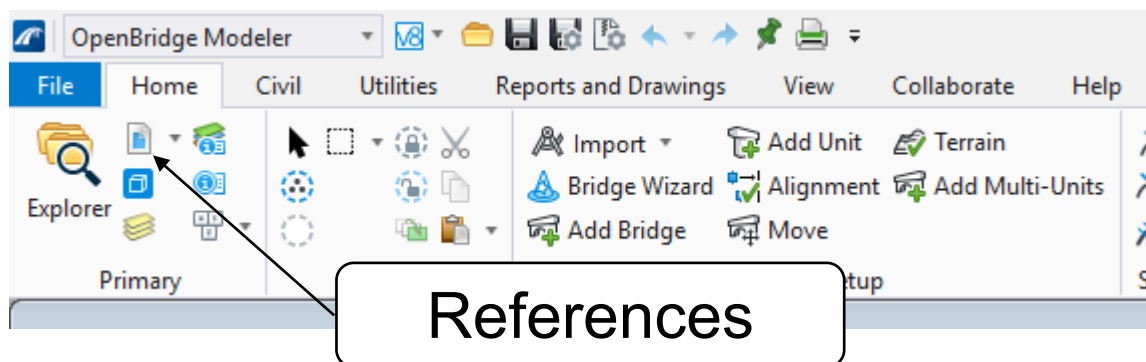

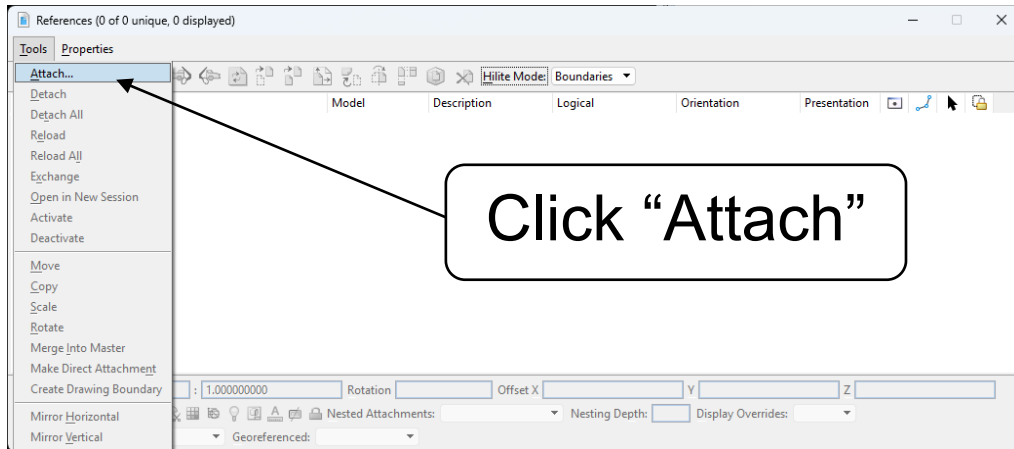

Navigate to the project Alignment folder and attach the alignment DGN.

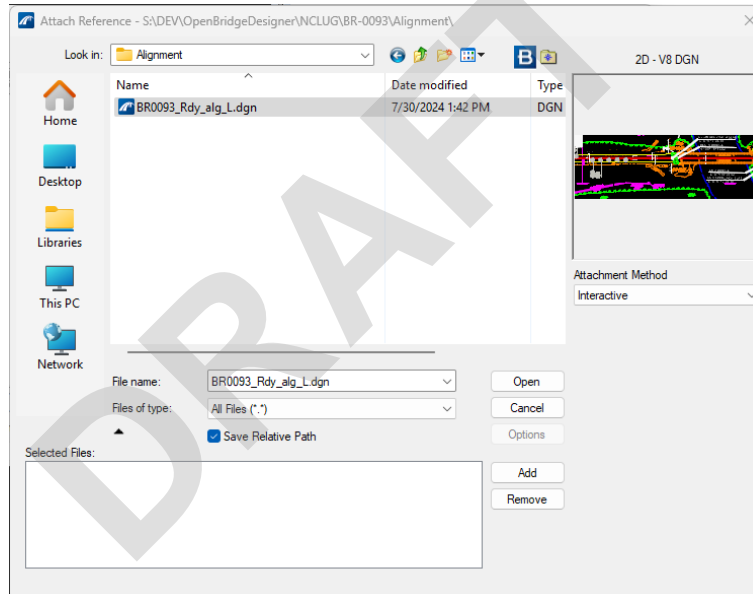

Note: ORD DGN's will produce a warning message about the WorkSet not being the same as the OBD WorkSet, click "OK" and continue.

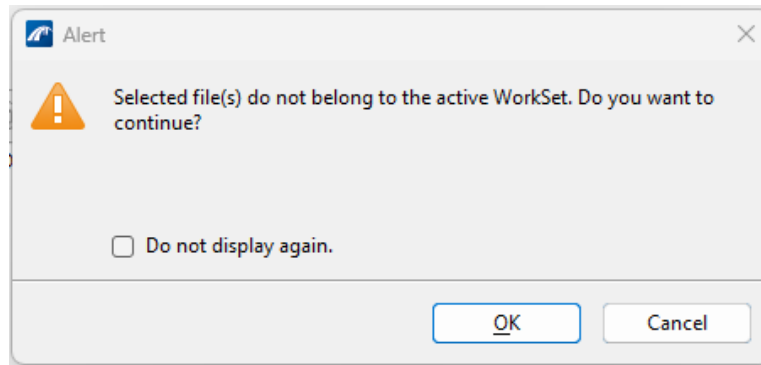

Make sure the referenced files are orientated to “Coincident-World” with “Live Nesting” at a depth of “99” to get all references of the roadway alignment, FS and ECTM files located in their correct location.

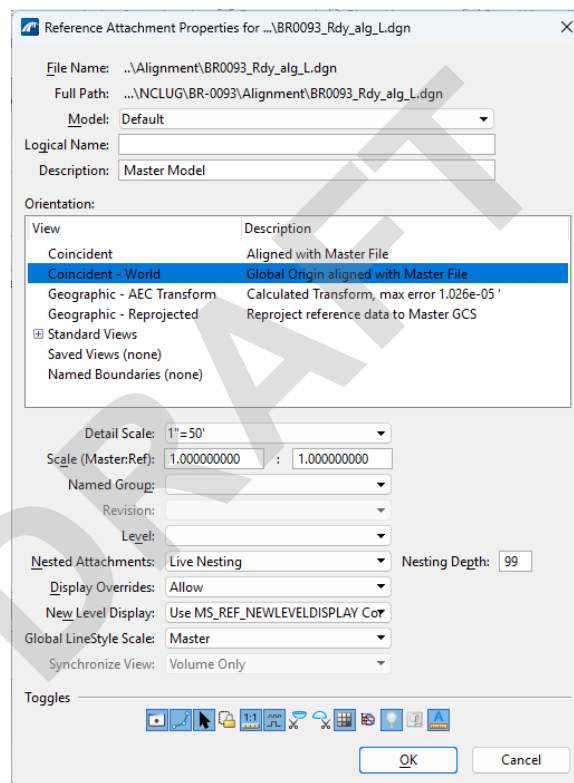

Step 2

After the reference files are attached and the views has been fit to the structure location. Then zoom to find the boundary of the terrain.

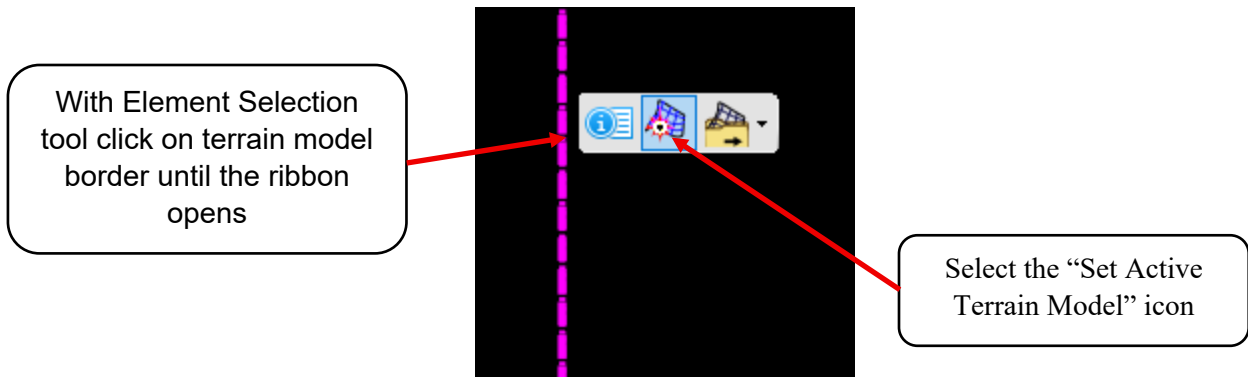

Step 3

Hover anywhere in the View 1 screen, click and hold the right mouse button, when the menu pops up **View Control > 3 Views Plan/Profile/3D**

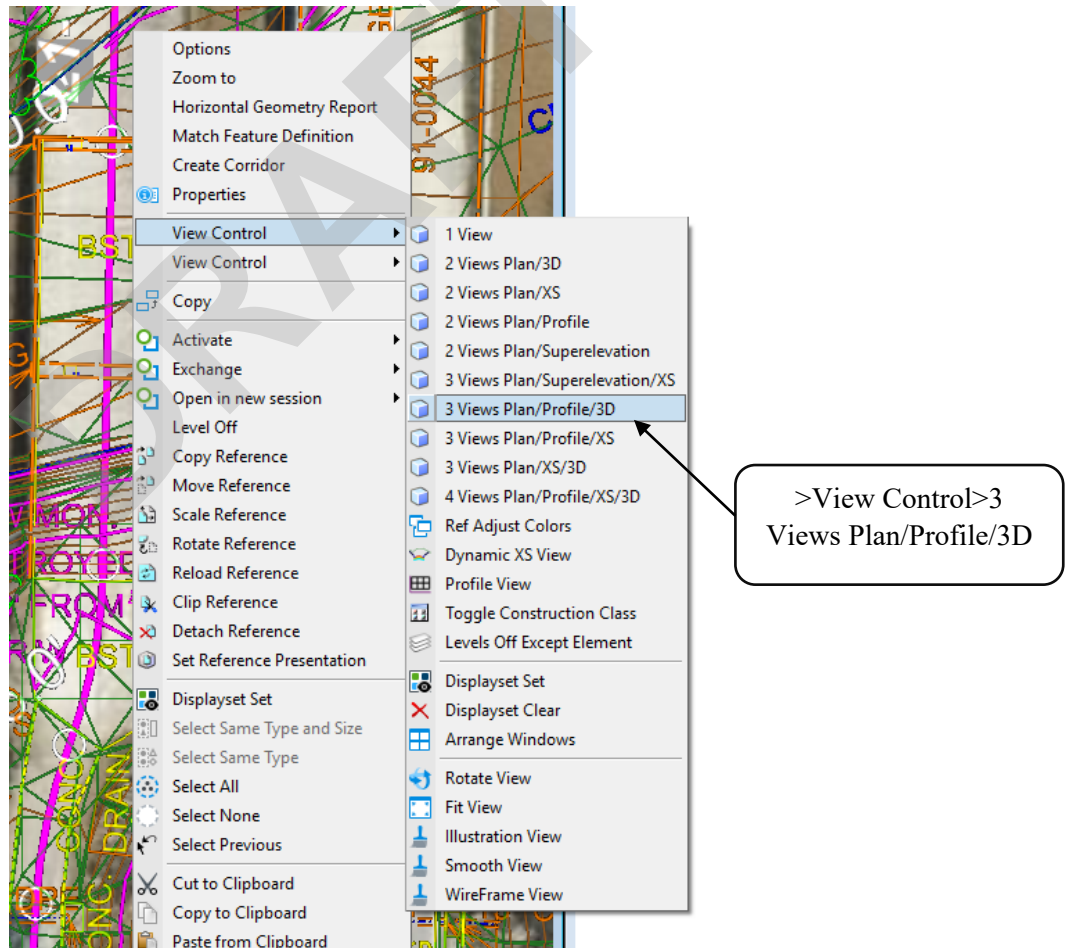

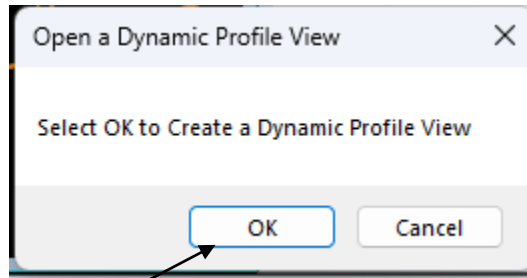

Click "OK"

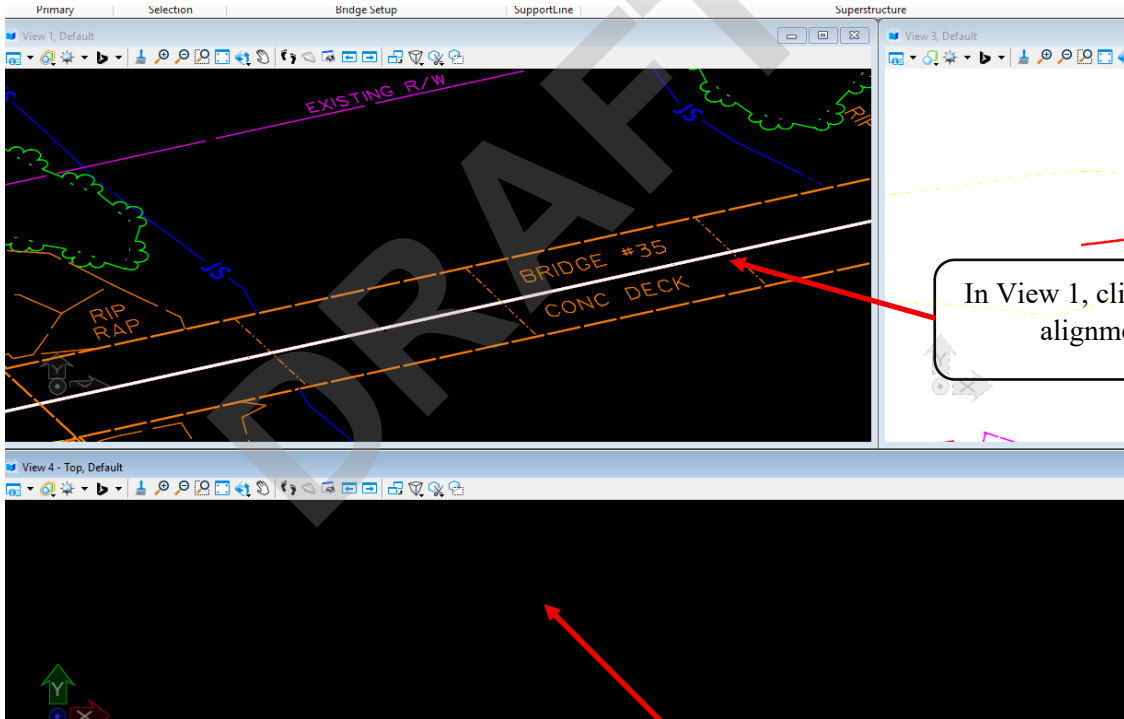

In View 1, click on the alignment

Then click in View 4

A multimodal view should be created

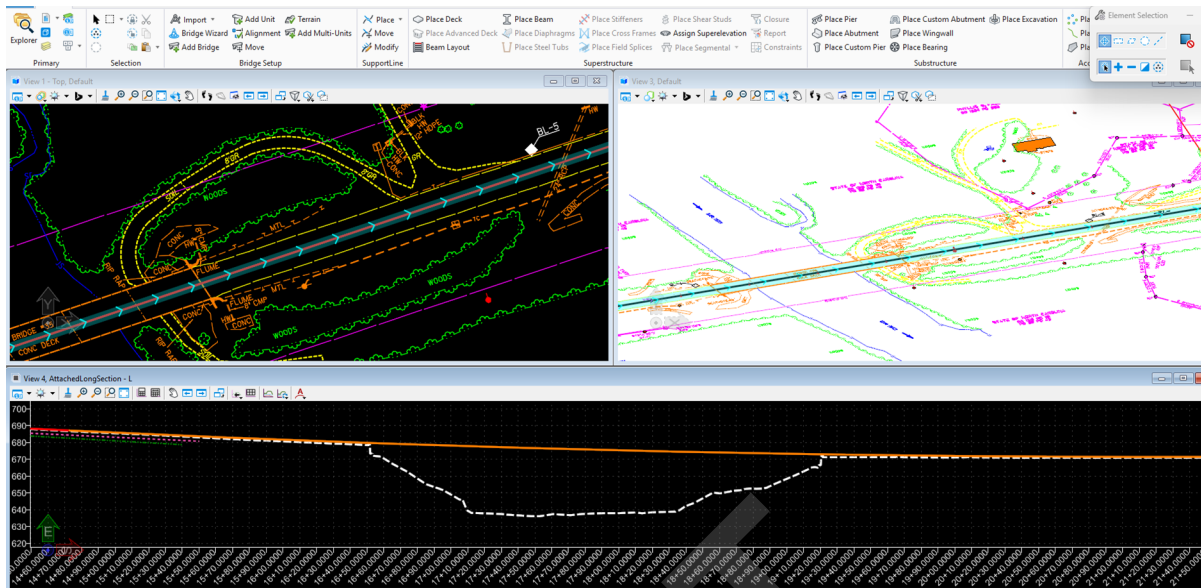

Move to Section 5.1.2 to create the PGD/GD plan and profile DGN.

6.1.1.2 Using v8/GEOPAK Survey Files

When no alignment files are available, the survey files can be used to create a plan and profile taking the following steps.

Step 1

Once the structure Model DGN has been created, go to the **Home tab > Primary ribbon > Attach Tools > References** find and attach the proposed alignment and/or FS and DTM files for the project as references. Make sure the referenced files are orientated to “Coincident-World” with “Live Nesting” at a depth of “99” to get all references of the roadway alignment, FS and DTM files located in their correct location.

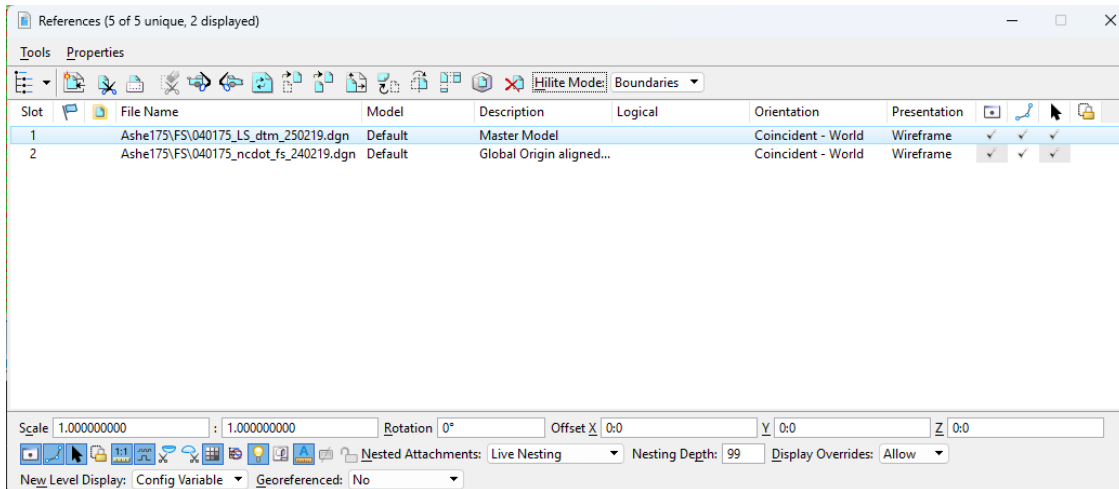

Then, **Home tab > Bridge Setup ribbon > Import Tool > Geometry** import the gpk file (geometry).

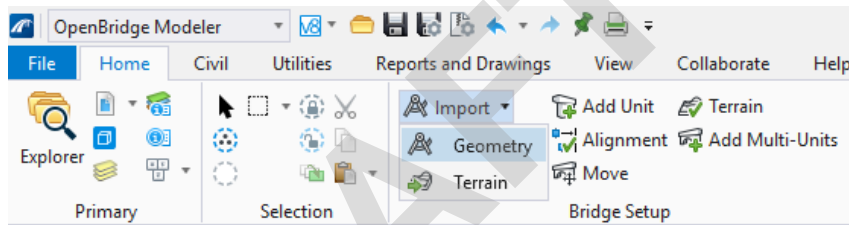

Select all the alignment information needed for the bridge location. Assign linear features from the NCDOT Features.

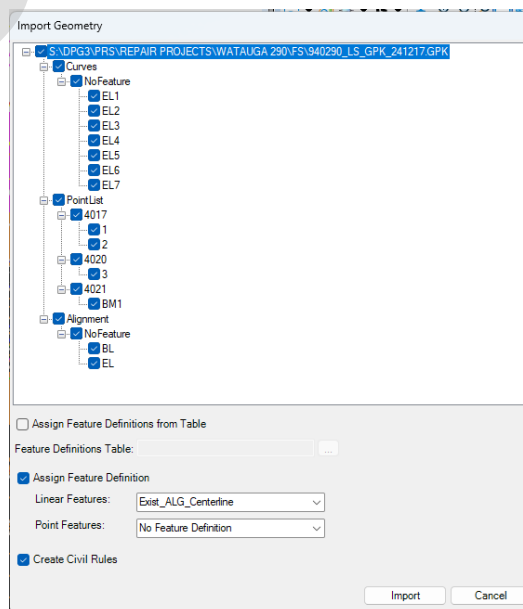

Next, **Home tab > Bridge Setup ribbon > Import Tool > Terrain** to import the tin files (terrain).

Assign feature definitions from the NCDOT Existing list, and select to see triangles and/or contours when the terrain is displayed. Note they can be turned off later if need be.

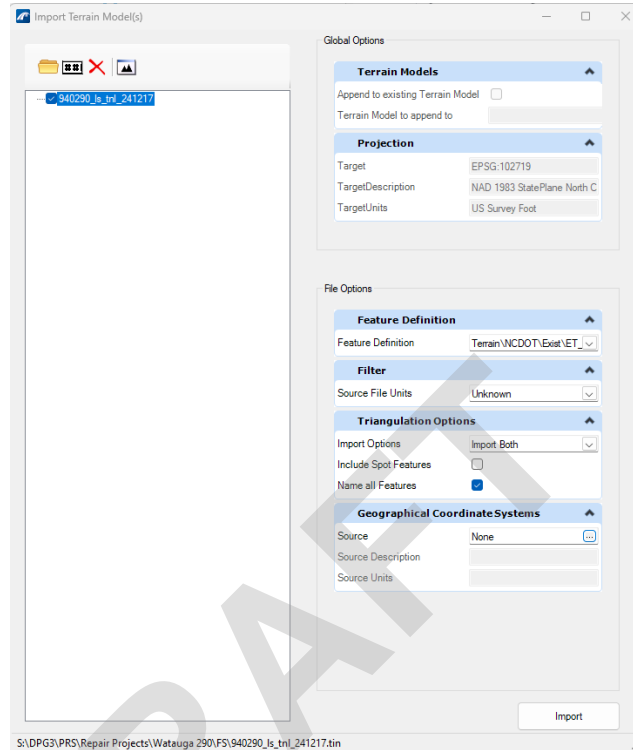

Step 2

After the reference files are attached and the views has been fit to the structure location.

Hover over the existing alignment created by L&S in the View 1 (plan view) to determine if there is an active profile line. In the image below, there is no active profile established for the existing alignment.

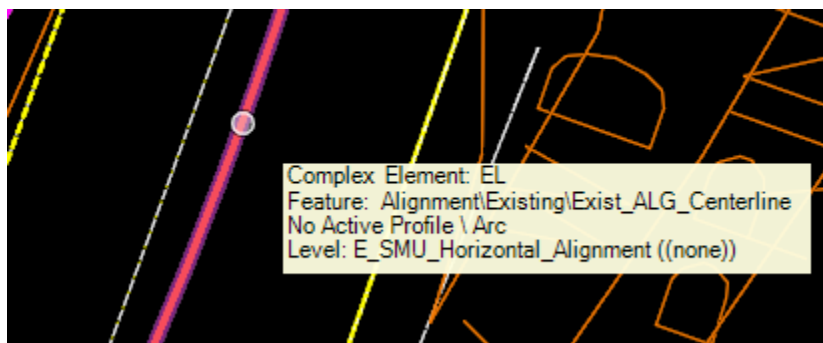

If there is an active alignment, skip the following steps and go to Section 5.1.2.

Step 3

To create an alignment, **Civil tab > Horizontal tools > Offsets and Tapers tool > Single Offset Entire Element**

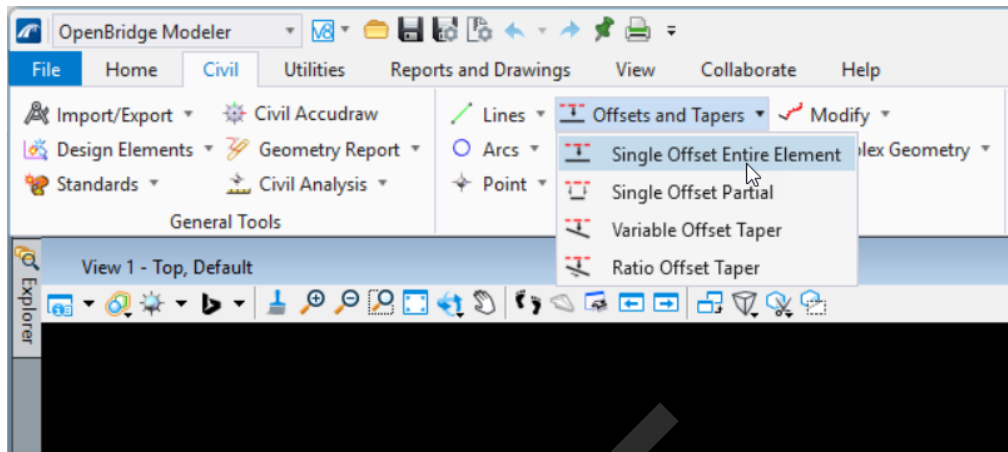

Before you click on the surveyed centerline of structure, set the parameters as follows:

- Offset: 0:0 (meaning no offset from the existing alignment element L&S created)
- Feature Definition: “Existing-Exist_ALG_Centerline”
- Name: Match L&S’s name

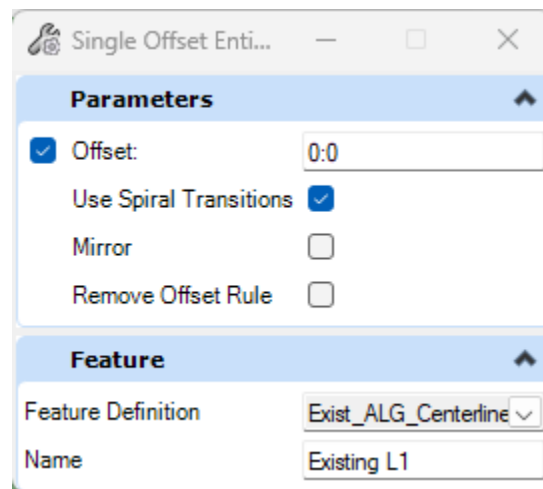
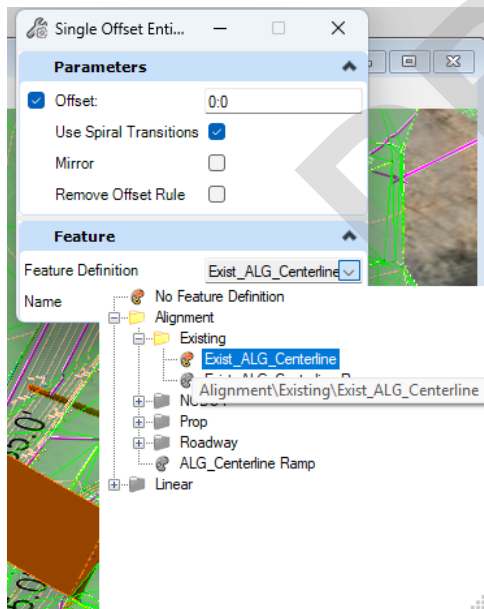

Once parameters are set...in the View 1 (plan view) window, click on the L&S alignment to select it, and to set it.

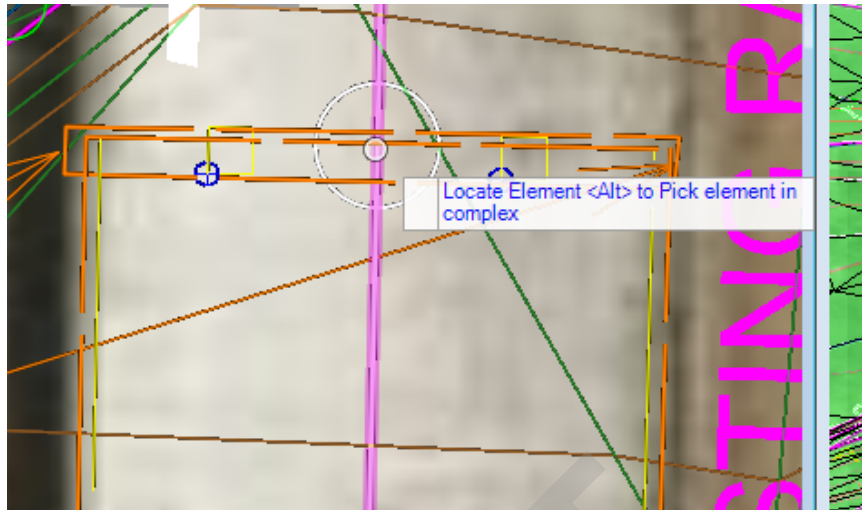

Step 4

To set the stations, **Horizontal > Modify Start Station** tool.

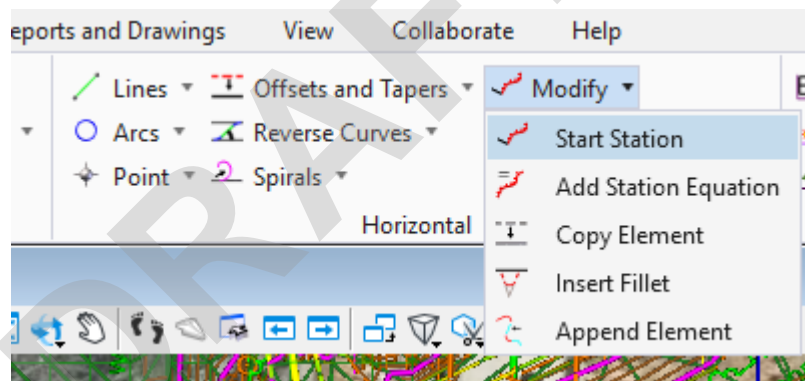

Set parameters as follows:

- Start Distance: 0'0"
- Start Station: 10+00.00
- Distance: 0'0"

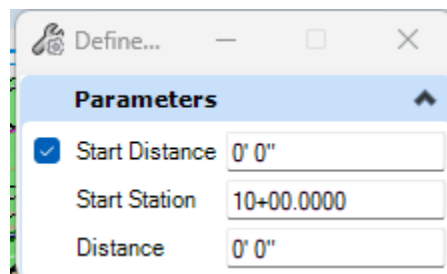

Then select the alignment in the plan view and follow the prompts, click to accept.

Step 5

Hover anywhere in the View 1 screen, click and hold the right mouse button, when the menu pops up **View Control > 3 Views Plan/Profile/3D**

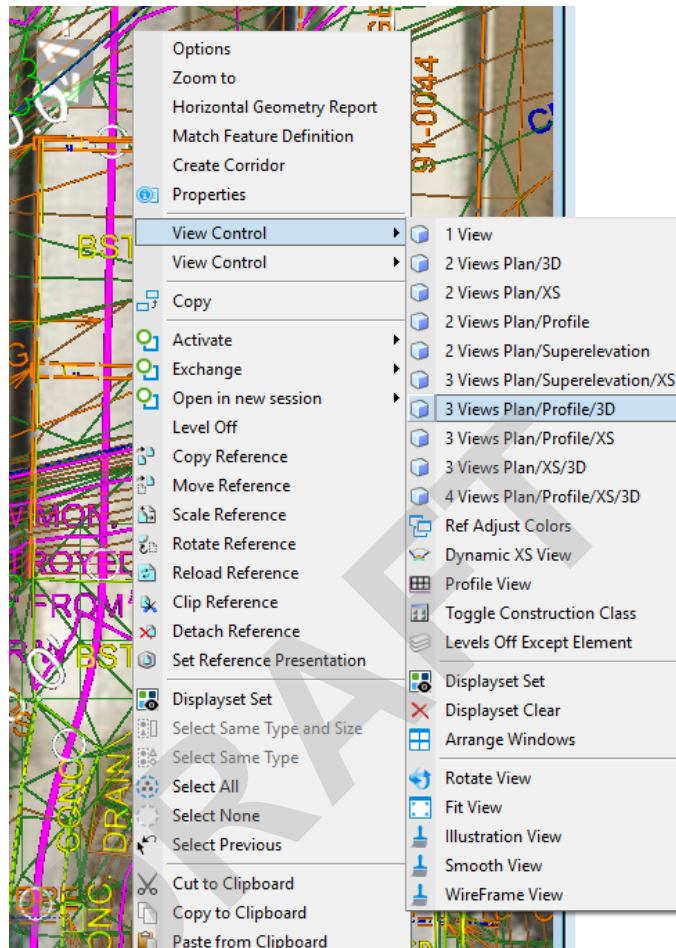

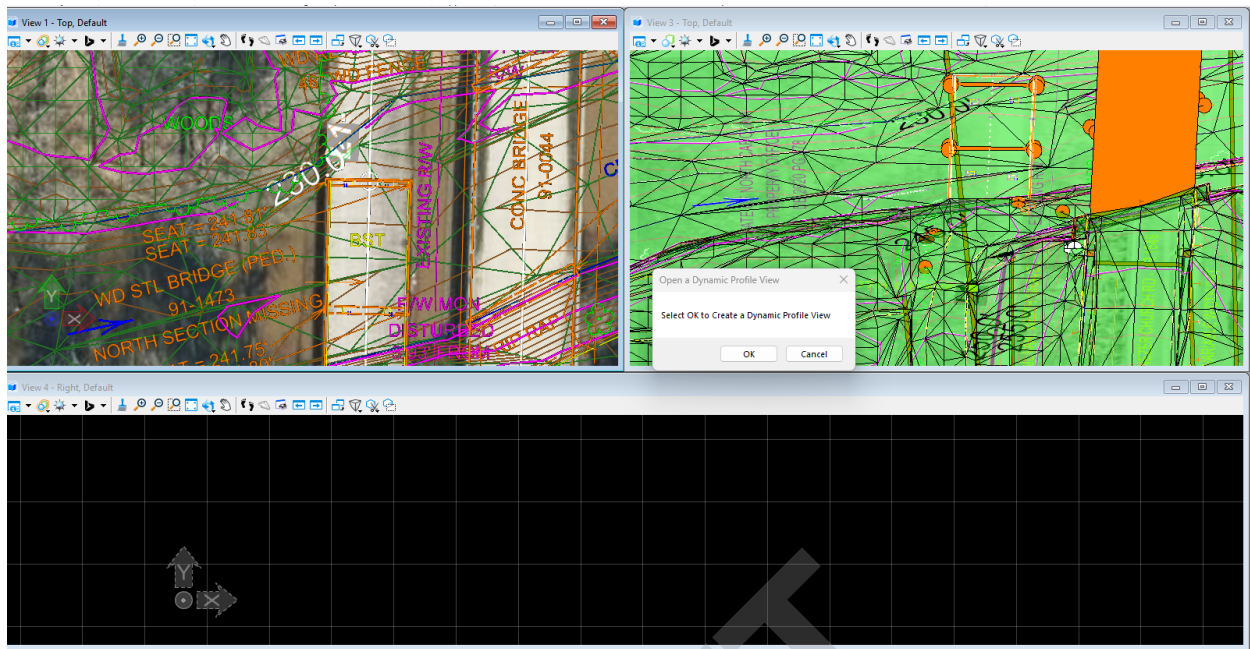

Select **OK** to create a dynamic profile view.

In View 1, click on the created alignment and then move your cursor to View 4 and click.

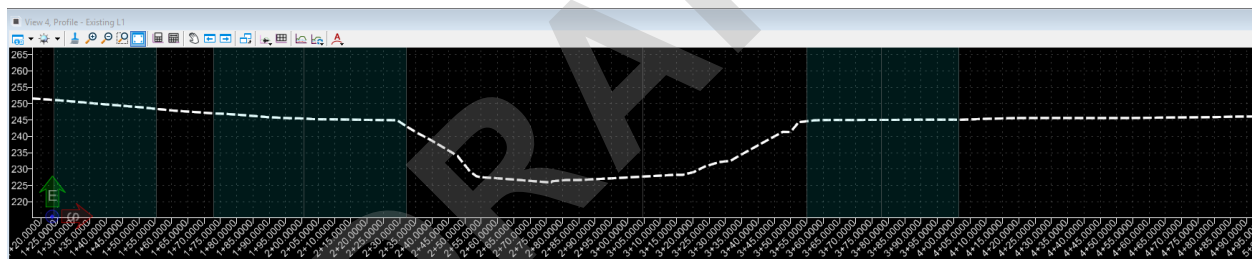

The profile along the alignment should appear in the View 4 window.

If it does not appear, zoom out in View 1 and activate the terrain file by finding the survey boundary line (the outline of the survey) and hovering over it until the property's icon toolbox pops up. Select the second icon "Set Active Terrain Model".

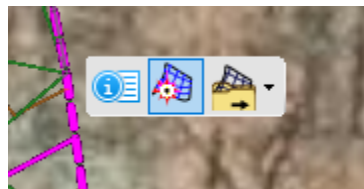

Go back to View 4 and click the "Fit View" icon and the profile should appear.

Step 6

To add a vertical alignment, **Complex Geometry > Profile Complex By PI tool**

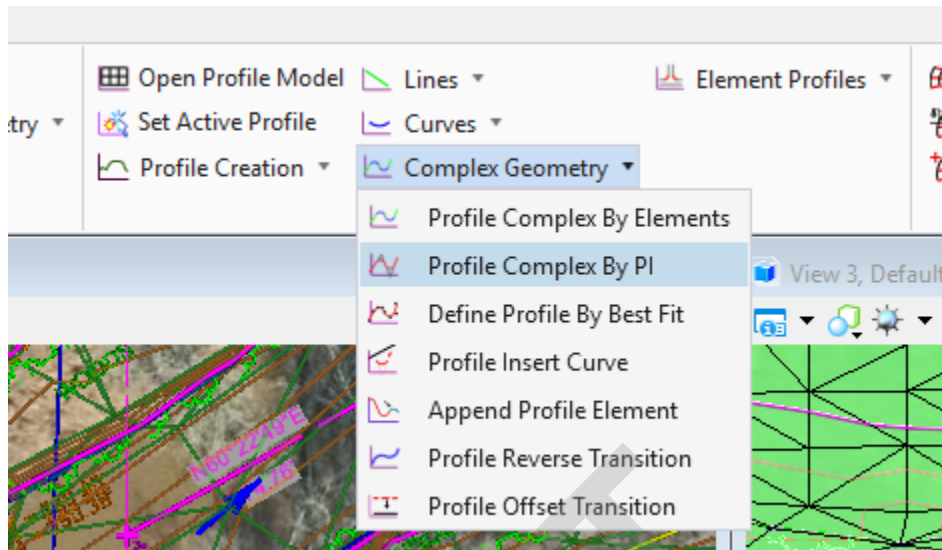

Set parameters as follows:

- Feature Definition: Existing > Existing_ALG_Centerline
- Name: match what was used in the Horizontal Offset and Tapers tool.

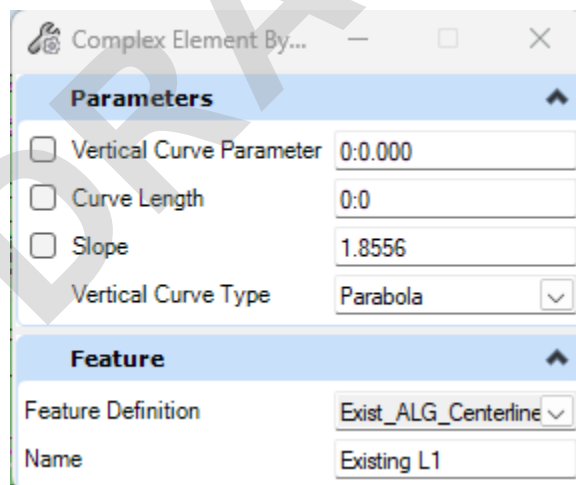

Then, use the tool in View 4 to click on points along the existing profile and create a vertical alignment.



Now, set the newly created alignment as “Active” by selecting it and move off and back on the line until the tool bar pops up. Once the menu bar appears, select the second icon **Set As Active Profile**.

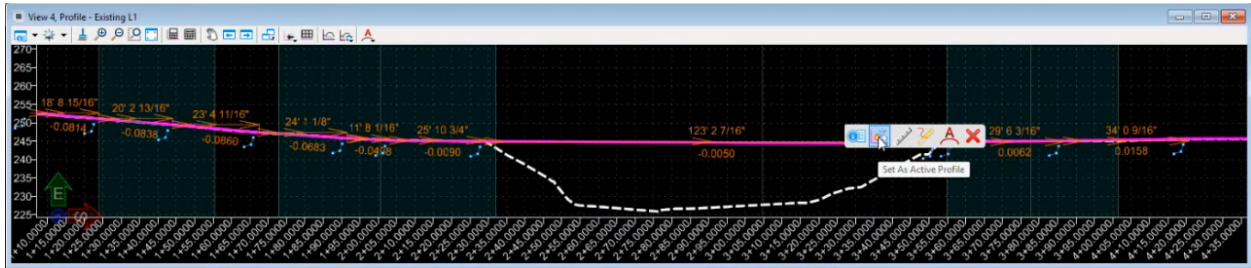

6.1.1.3 Using ORD Survey Files

When no alignment files are available, the survey files can be used to create a plan and profile taking the following steps.

Step 1

Once the structure Model DGN has been created, **Home tab > Primary ribbon > Attach Tools > References** find and attach the roadway alignment file ALG, and/or survey files FS and ECTM for the project as references. Make sure the referenced files are orientated to “Coincident-World” with “Live Nesting” at a depth of “99” to get all references of the ALG, FS and ECTM files located in their correct location.

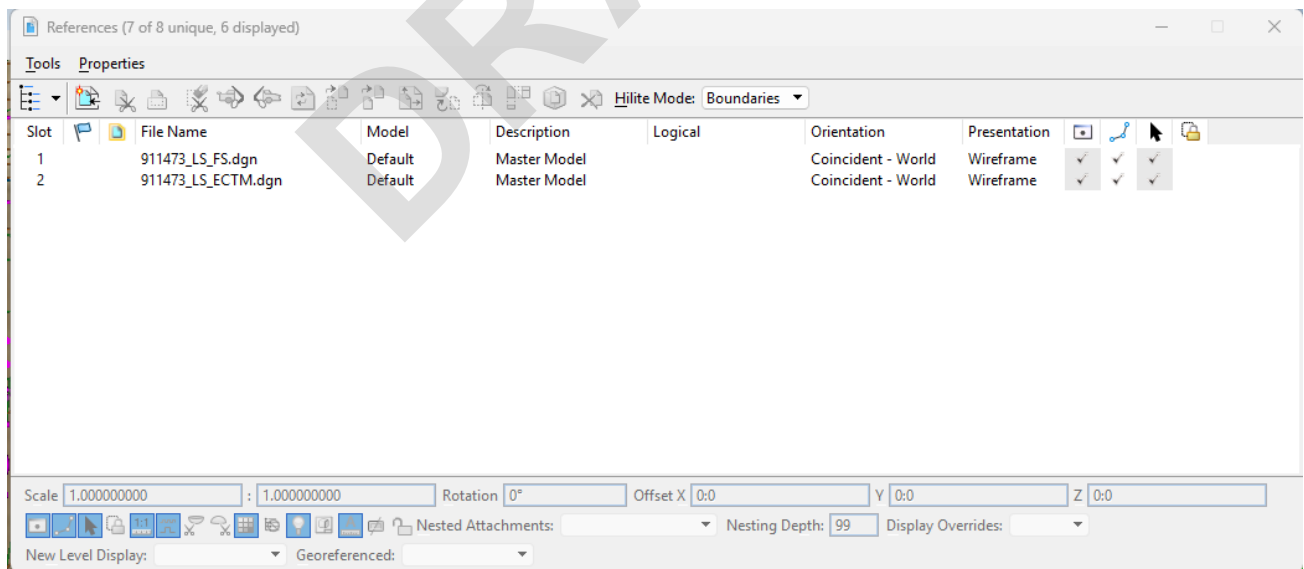

Step 2

After the reference files are attached and the views has been fit to the structure location.

Hover over the existing alignment created by L&S in the View 1 (plan view) to determine if there is an active profile line. In the image below, there is no active profile established for the existing alignment.

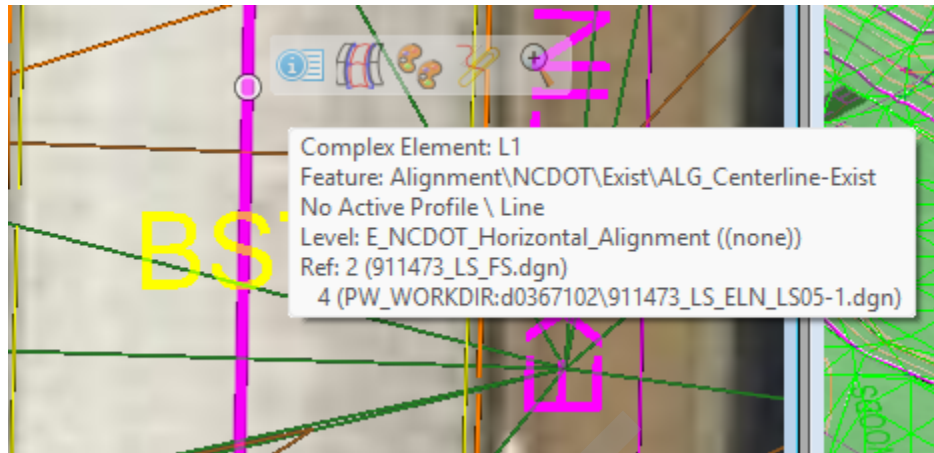

If there is an active alignment profile from the ALG file, skip the following steps and go to Section 5.7.2.

Step 3

To create an alignment, **Civil tab > Horizontal tools > Offsets and Tapers tool > Single Offset Entire Element**

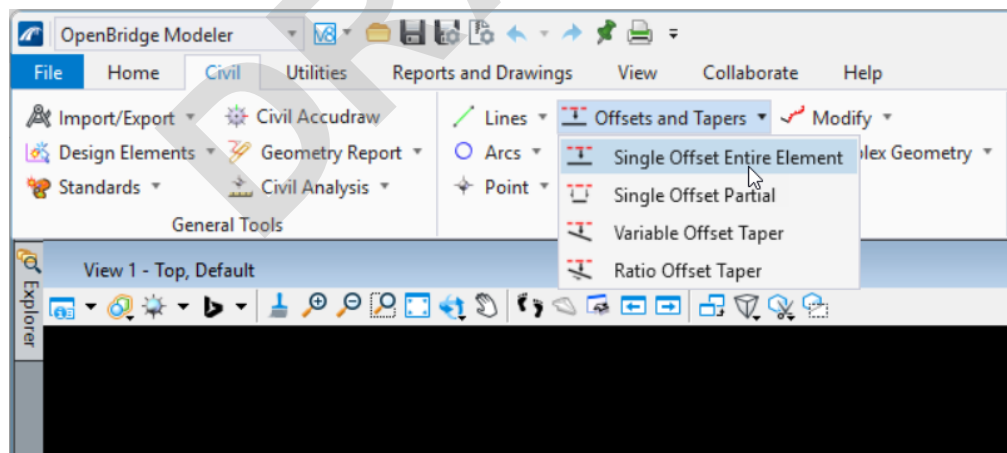

Before you click on the surveyed centerline of structure, set the parameters as follows:

- Offset: 0:0 (meaning no offset from the existing alignment element L&S created)
- Feature Definition: “Existing-Exist_ALG_Centerline”
- Name: Match L&S’s name

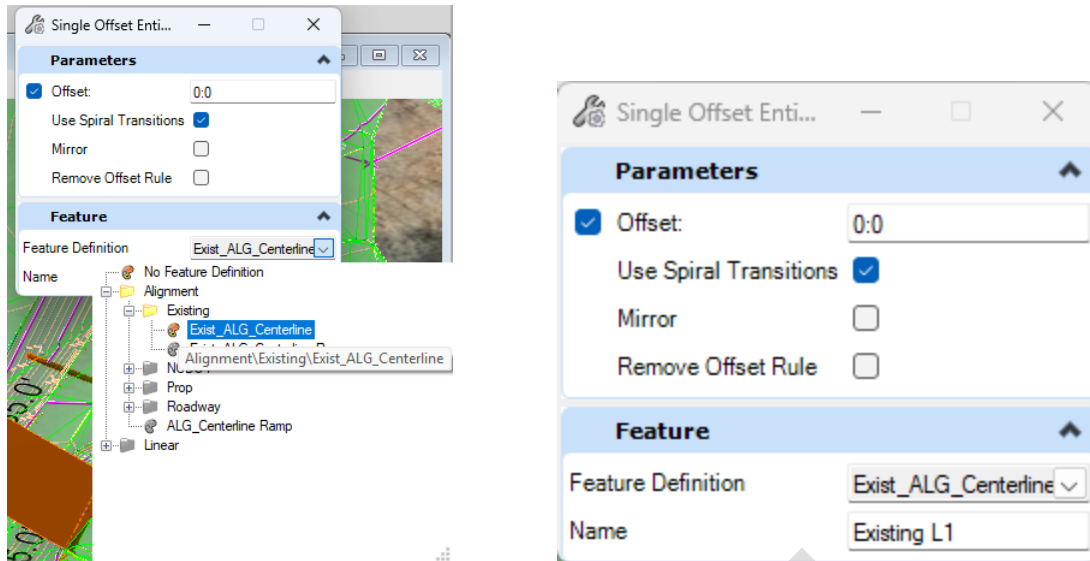

In View 1 (plan view), click on the L&S alignment to select it, and to set it.

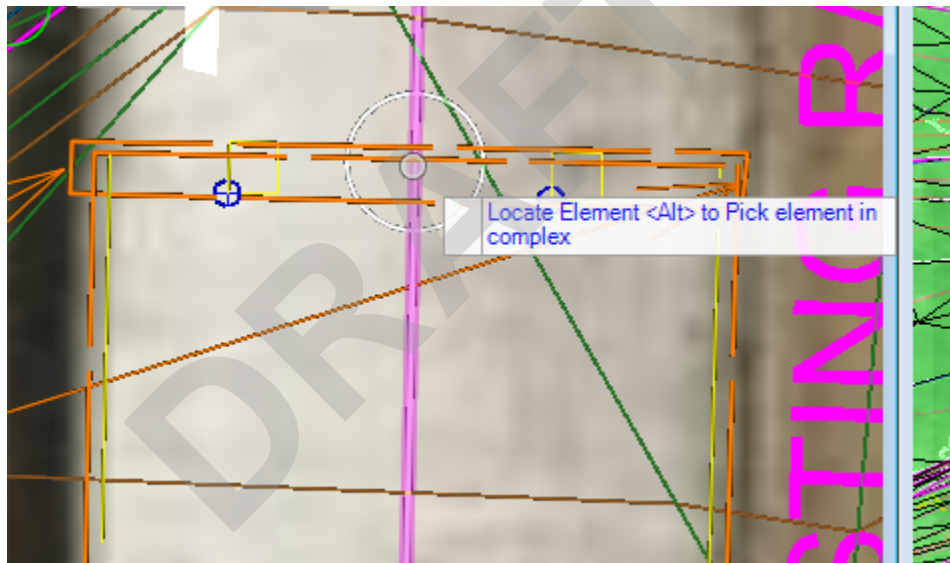

Step 4

To set the stations, **Horizontal > Modify Start Station tool.**

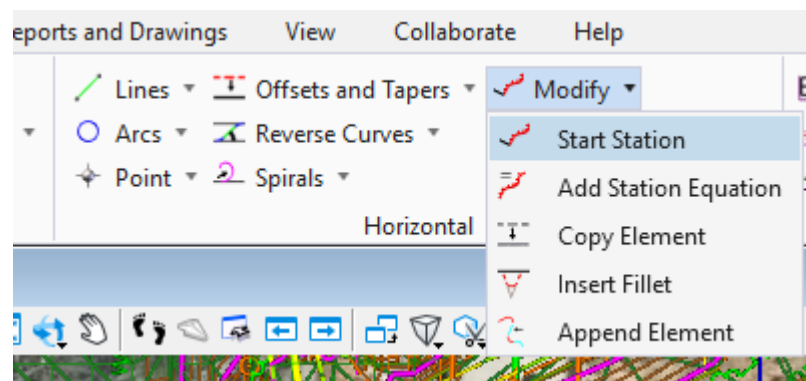

Set parameters as follows:

- Start Distance: 0'0"
- Start Station: 10+00.00
- Distance: 0'0"

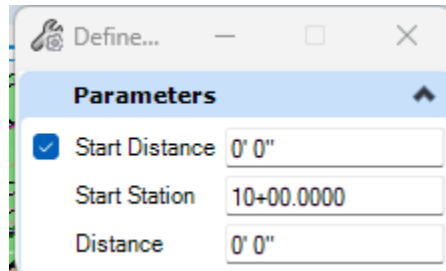

Then select the alignment in the plan view and follow the prompts, click to accept.

Step 5

Hover anywhere in the View 1 screen, click and hold the right mouse button, when the menu pops up **View Control > 3 Views Plan/Profile/3D**

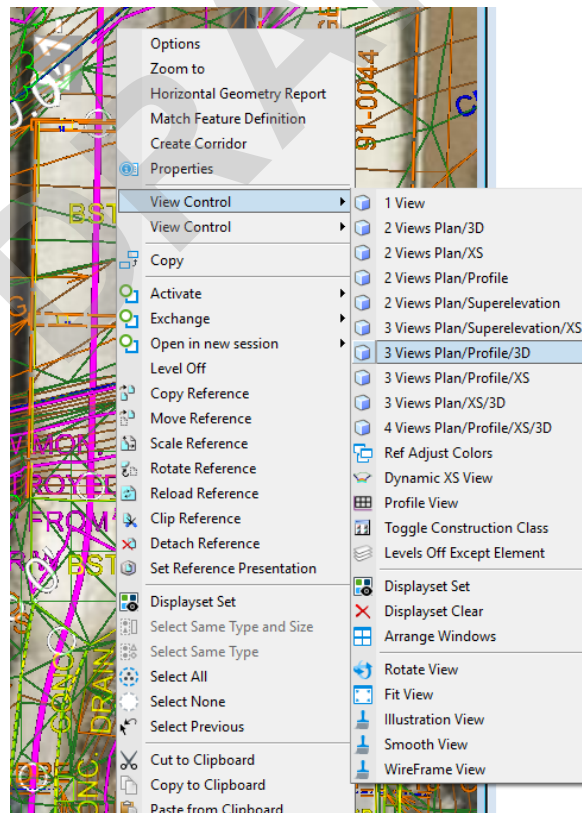

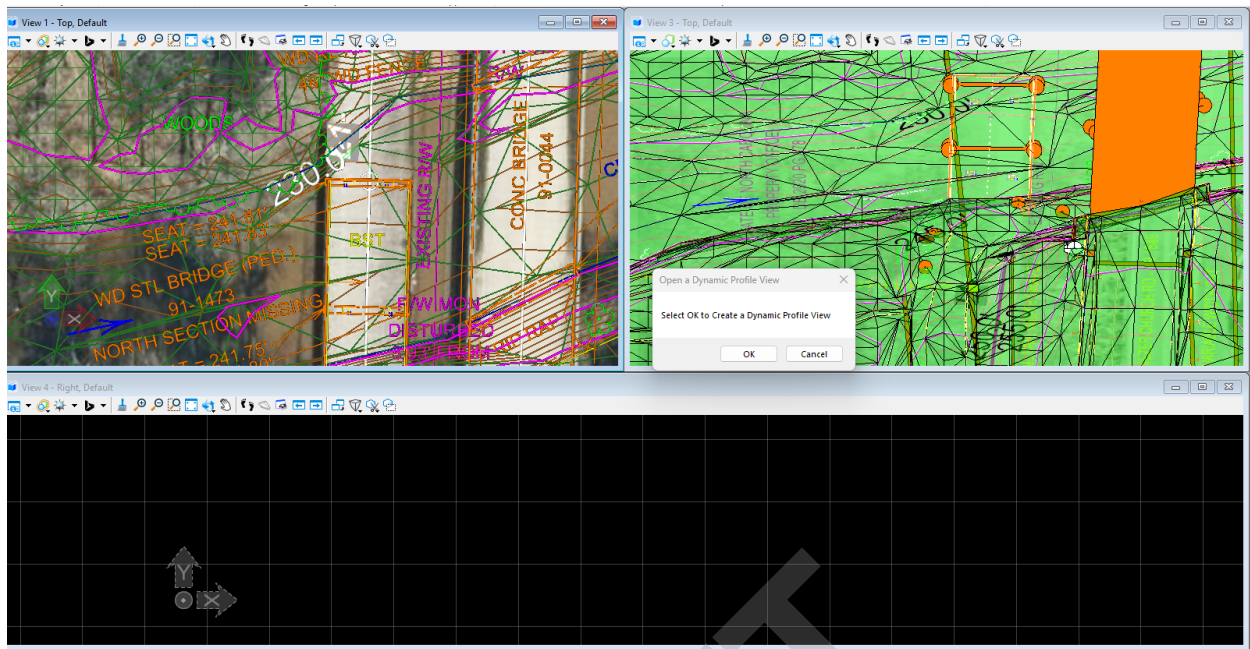

Select **OK** to create a dynamic profile view.

In View 1, click on the created alignment and then move your cursor to View 4 and click.

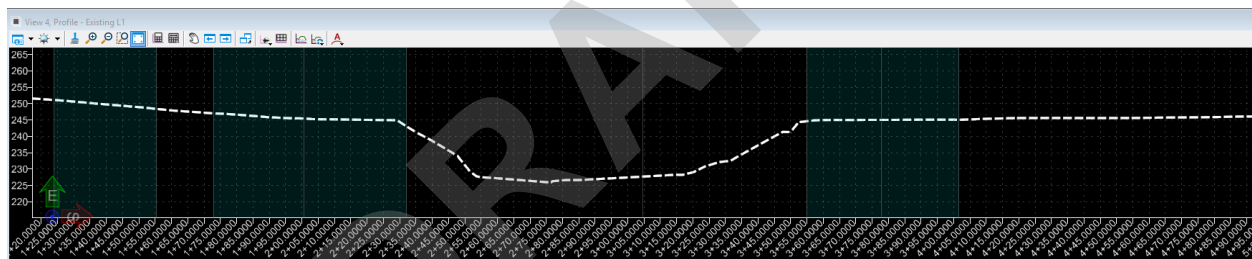

The profile along the alignment should appear in the View 4 window.

If it does not appear, zoom out in View 1 and activate the terrain file by finding the survey boundary line (the outline of the survey) and hovering over it until the property's icon toolbox pops up. Select the second icon "Set Active Terrain Model".

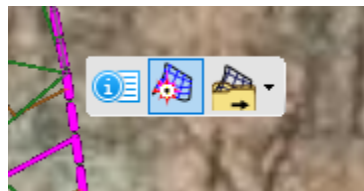

Go back to View 4 and click the "Fit View" icon and the profile should appear.

Step 6

To add a vertical alignment, **Complex Geometry > Profile Complex By PI tool**

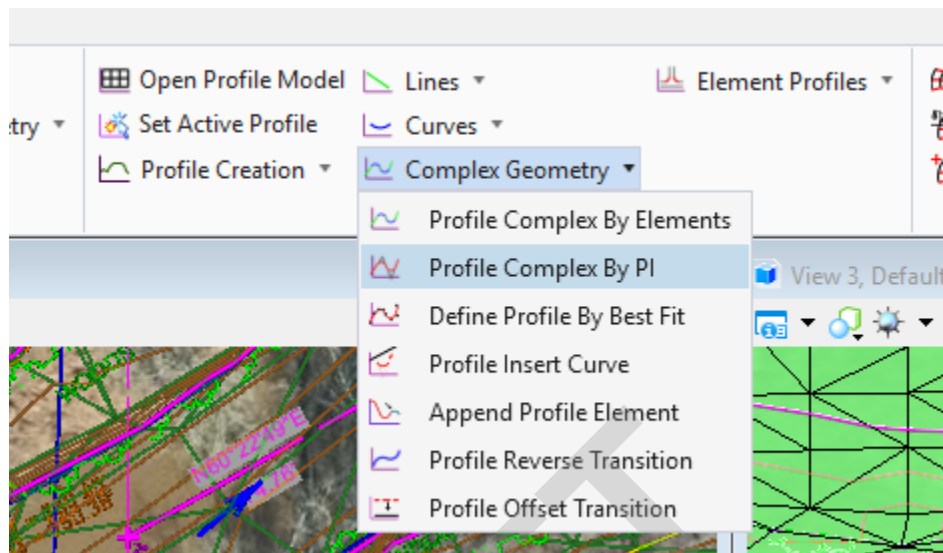

Set parameters as follows:

- Feature Definition: Existing > Existing_ALG_Centerline
- Name: match what was used in the Horizontal Offset and Tapers tool.

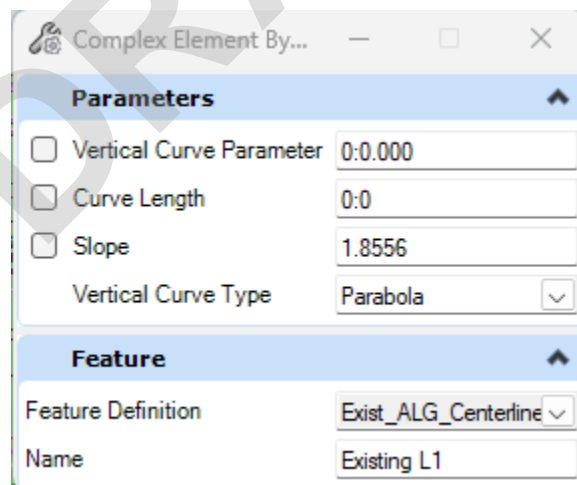

Then, use the tool in View 4 to click on points along the profile and create a vertical alignment.



Now, set the newly created alignment as “Active” by selecting it and move off and back on the line until the tool bar pops up. Once the tool bar appears, select the second icon **Set As Active Profile**.

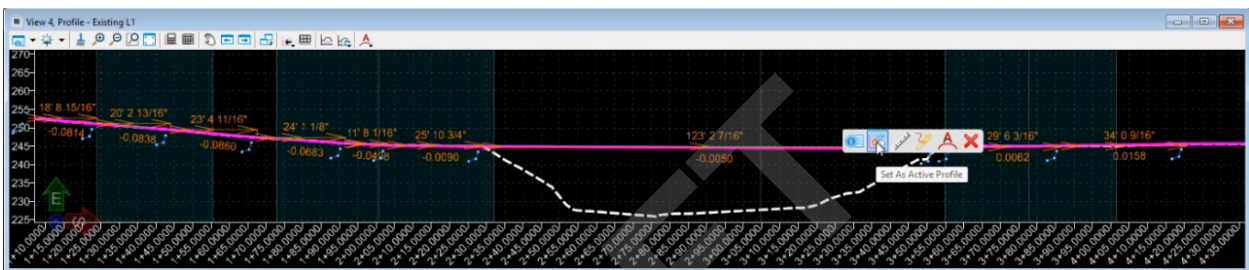

6.1.2 Creating A Plan and Profile Plan Sheet

After the 3D Model DGN has been completed, create the DGN file for the PGD and/or GD to create the plan and profile views.

Once the DGN is created, go to the **Home tab > Primary ribbon > Attach Tools > References** and reference in the newly created Existing 3D Alignment Model DGN.

Once referenced, in **View 1:** right click and hold the right mouse button **View Control > 2 Views Plan/Profile**

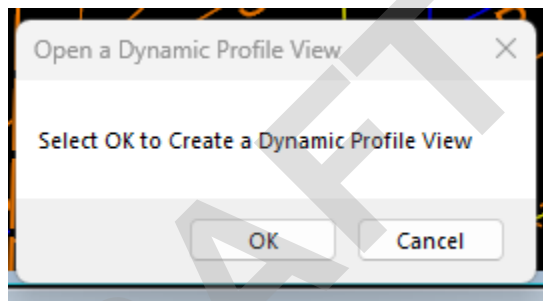
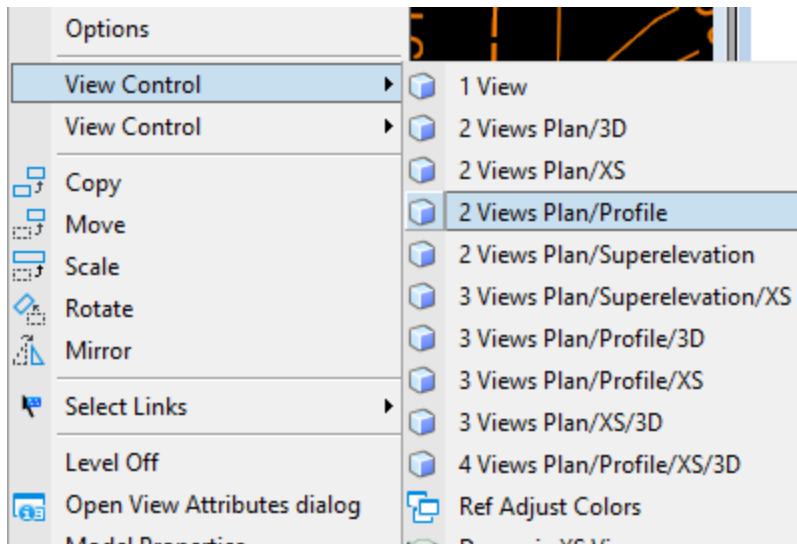

Select **OK** to create a dynamic profile view.

In **View 1**, click on the alignment and then move your cursor to **View 4** and click.

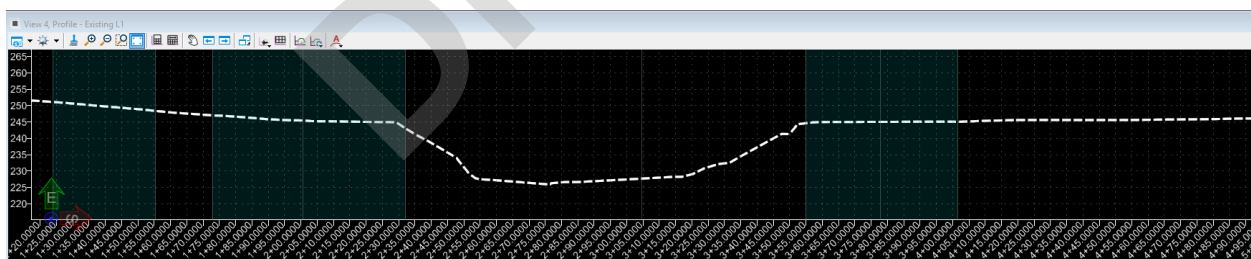

The profile along the alignment should appear in the View 4 window.

6.1.2.1 Creating the Plan View

In the **View 1** window, select the **Place Named Boundary tool > Civil Plan**.

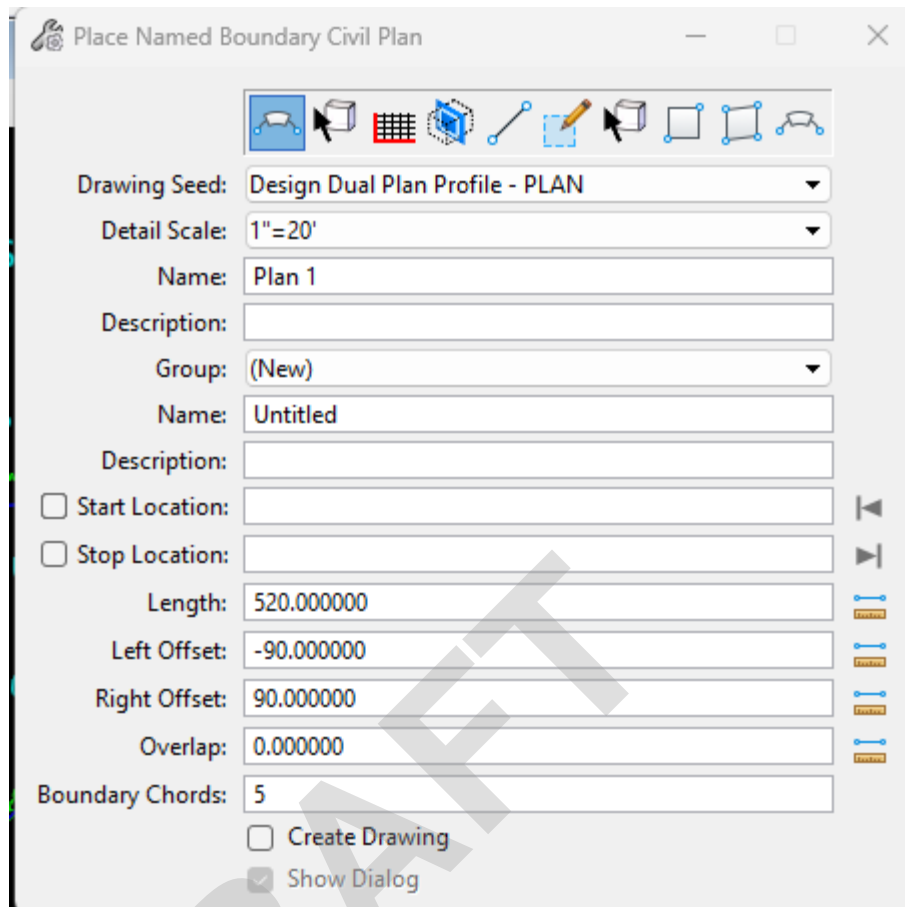

Select the following:

- Drawing Seed: Design (or PRR) Dual Plan Profile-PLAN
- Detail Scale: select a scale that will encompass the structure in the plan view.
 Tip: change the detail scale and check the length value compared to the bridge length, the length should be long enough to include the entire bridge, the approach slabs, plus some approach roadway on each end of the bridge.
- Boundary Chords: set the boundary chords to 1 to place only one boundary or the minimum number of boundaries required to fit the entire bridge to look correct on a plan sheet.
- Create Drawing: UNCHECKED

To place the plan sheet in View 1, select the alignment ahead of the bridge. The outline of the plan sheet should appear, if the box does not encompass the entire bridge and approaches as desired right click to cancel the placement. If the outline of the plan sheet encompasses the desired view, click ahead station to place it. Take note of the detail scale selected, it will be needed in further steps.

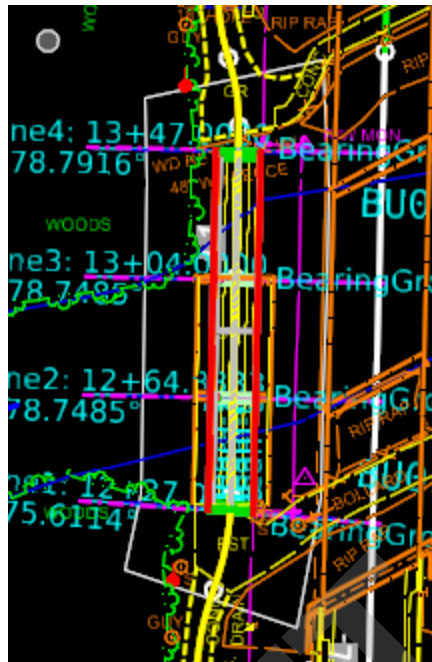

Note the Place Named Boundary tool might close during this step, reopen it to move to the Civil Profile tool.

Annotating The Plan View

To use the Civil Labeler tool to annotate the plan view, go to the Default Design Model and add workpoints to the alignment using the steps found in Section 3.8.2.1.

In the Plan View Drawing Model, use the workpoints placed to draft the 2D layout of the substructure elements needed for the plan view.

In the Plan View Drawing Model, use the Civil Labeler tool to annotate the workpoint stations by going to **Reports and Drawings > Civil Labeler**

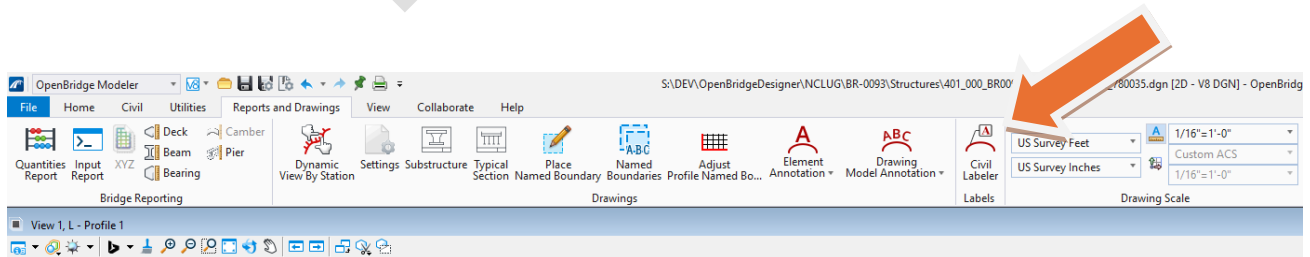

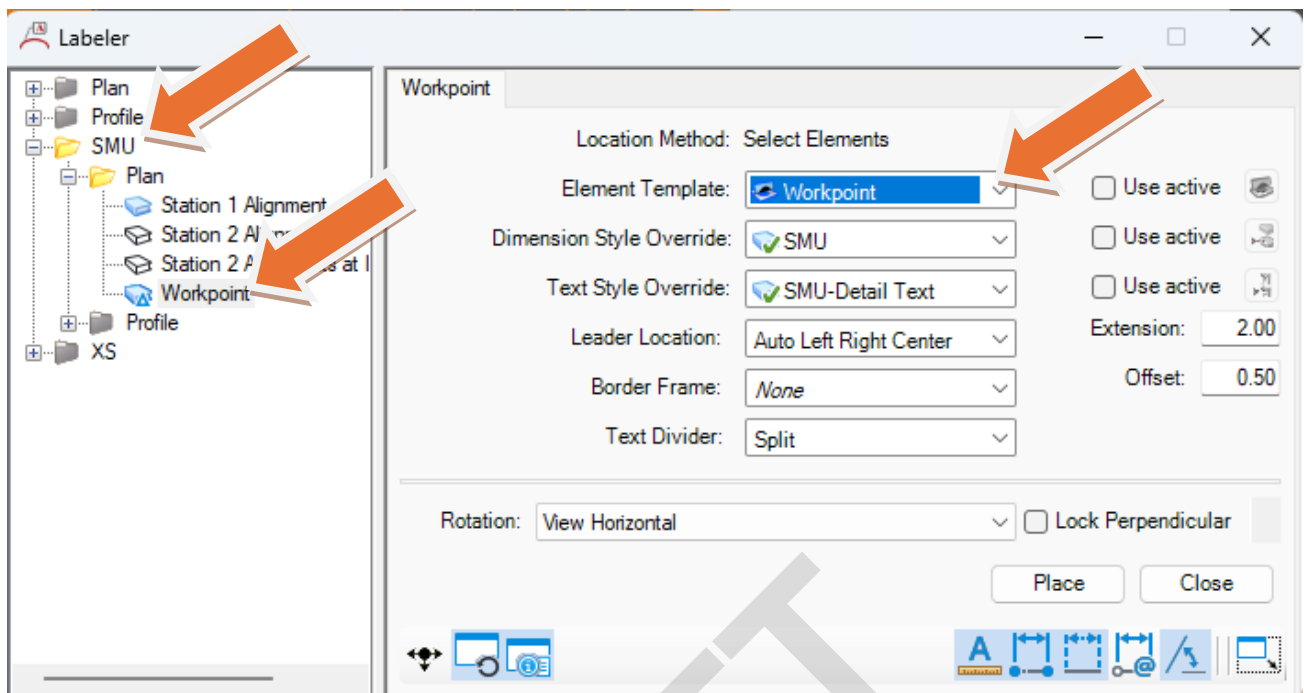

Select the alignment, then the stations where the callout is to be placed.

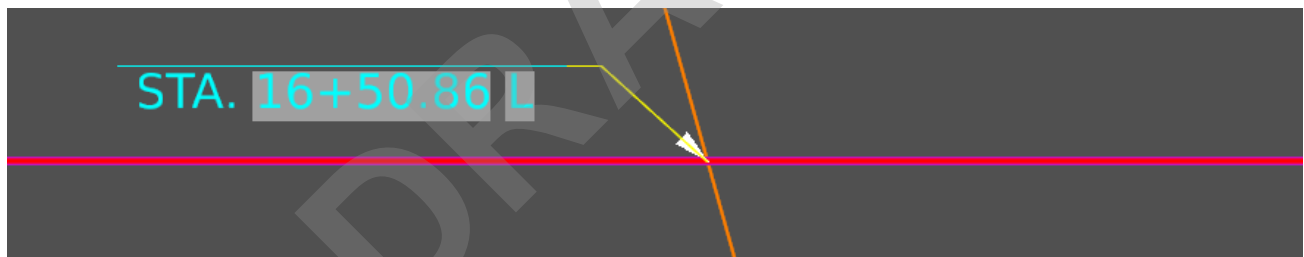

6.1.2.2 Creating the Profile View

In View 4 window, select the **Place Named Boundary tool > Civil Profile**.

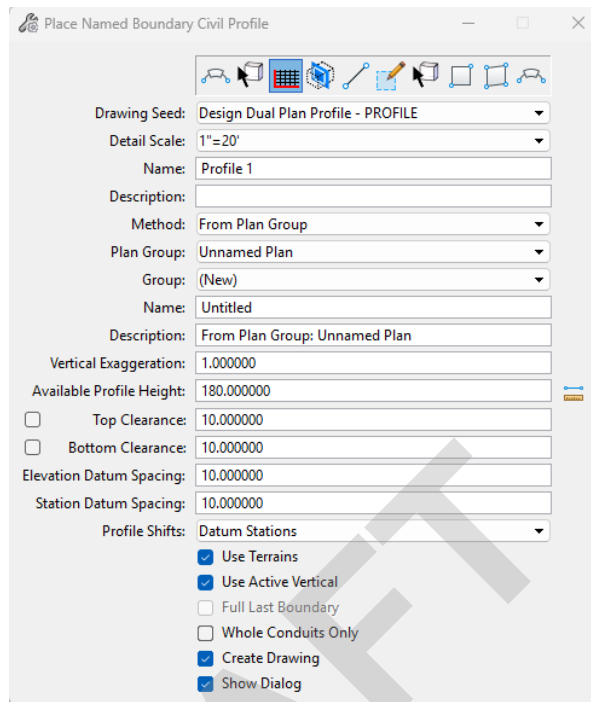

Select the following:

- Drawing Seed: Design or PRR Dual Plan Profile-PROFILE,
- Detail Scale: set the scale to match the plan view scale.
- Method: From Plan Group, this will place the profile box in the same place as the plan view box placed earlier.
- Select the “Create Drawing” box.

In View 4, click on the alignment to place the box. Note the box should appear in the same stations as where the plan view box was placed.

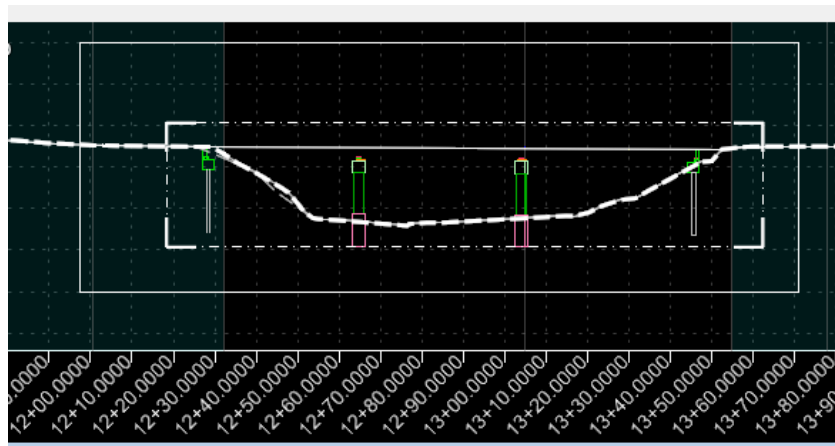

Once the box is placed, the following tool box will open up:

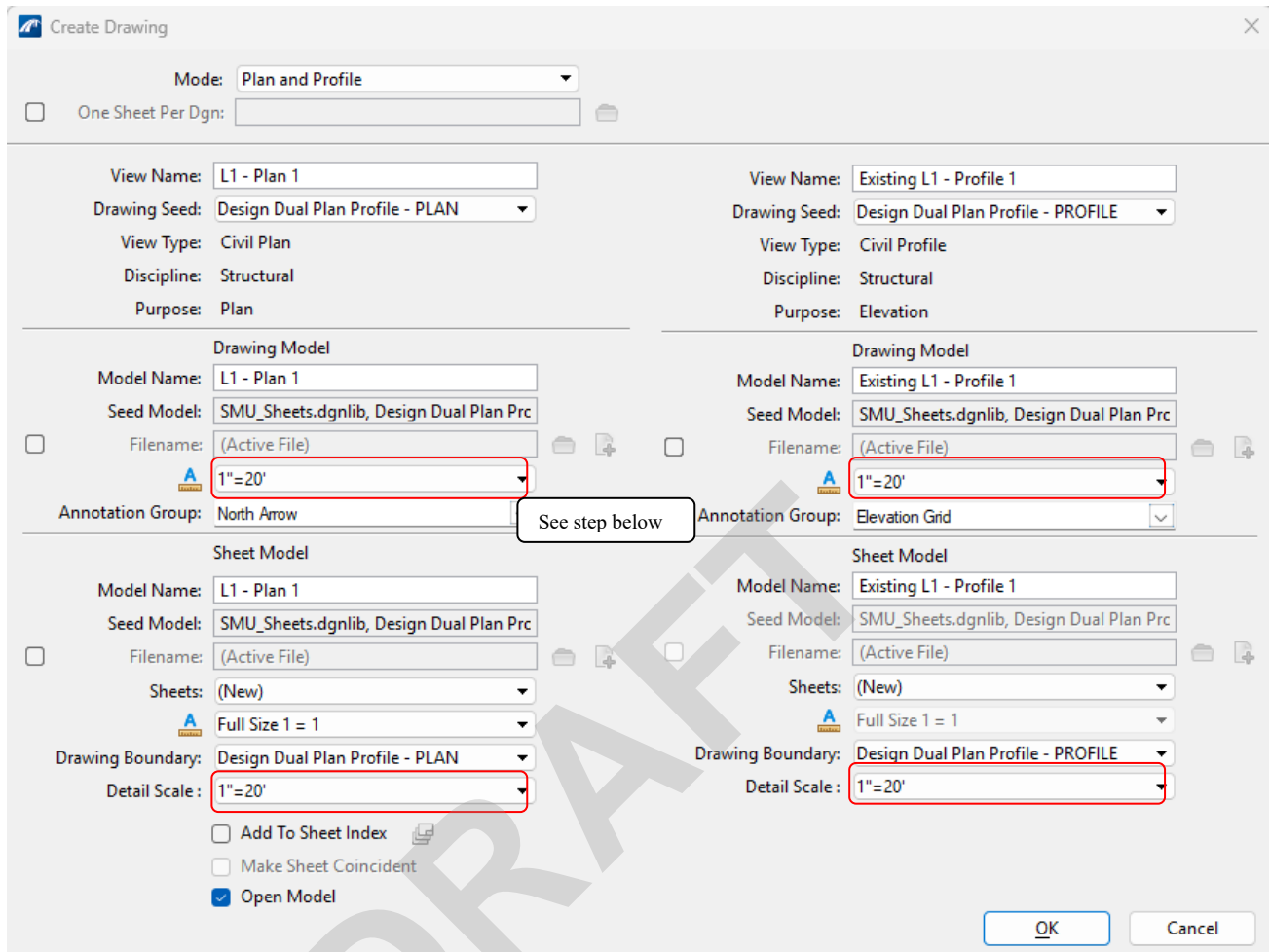

It is important to make sure all the scales match before clicking “OK”.

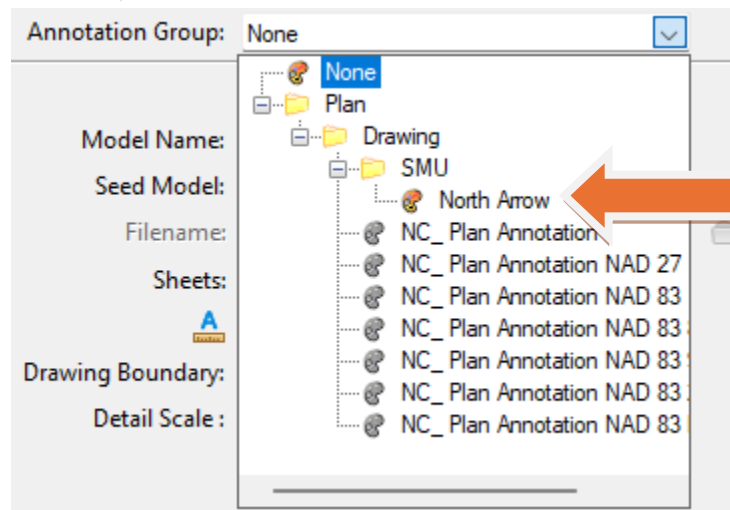

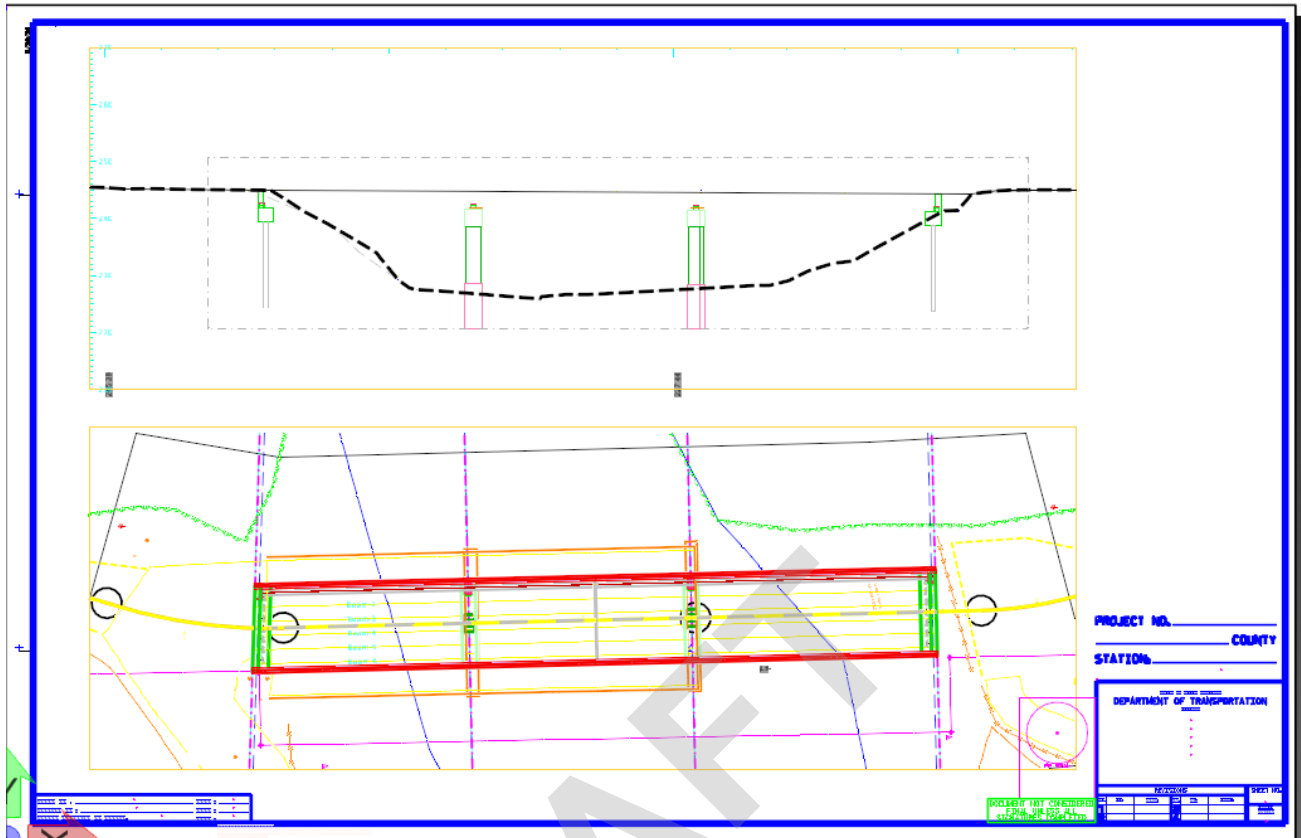

Annotate the Profile Drawing Model

In the bottom left of the screen, select the Profile Drawing Model.

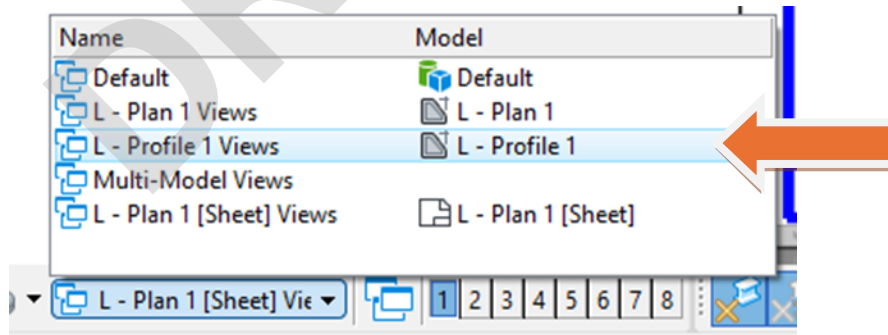

In the Profile Drawing Model, use the elevations and stations automatically placed to draft the 2D elevation layout of the substructure elements and slope protection needed for the profile view.

****Note:** In the future, the Rip Rap layout will be provided by the Hydraulics model.

To label elevations, go to **Reports and Drawings > Civil Labeler**

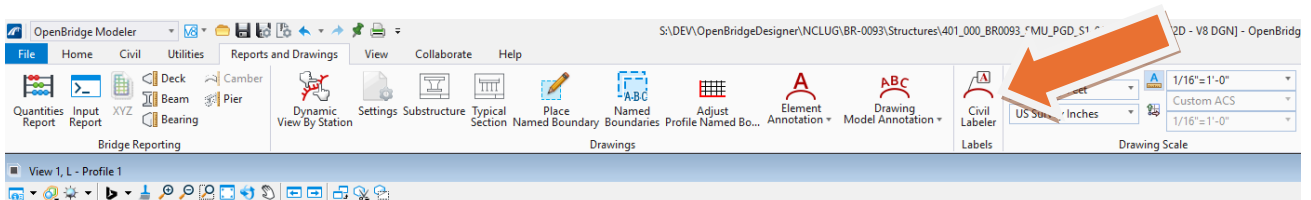

Use the SMU Profile Existing Elevation tool.

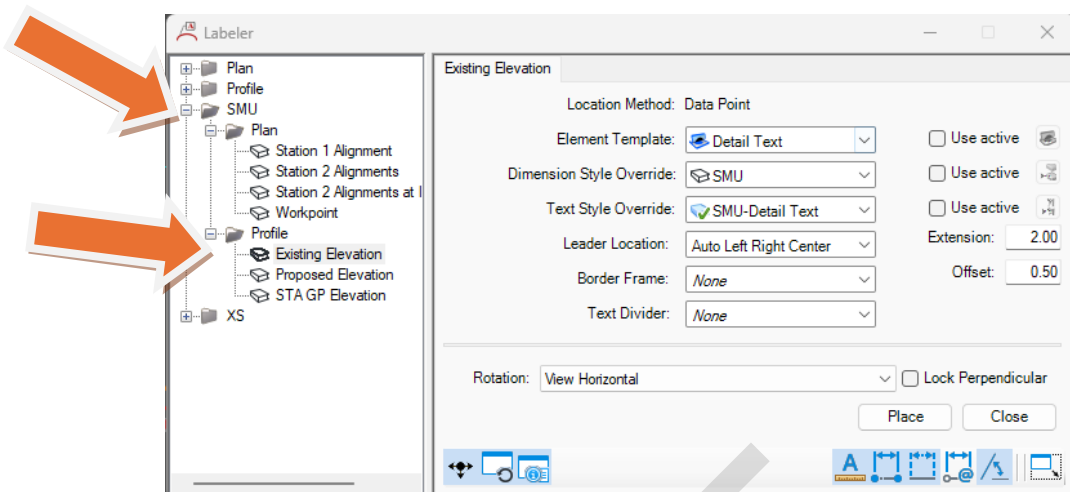

Select the existing profile line, then select the locations and place elevation labels as needed.

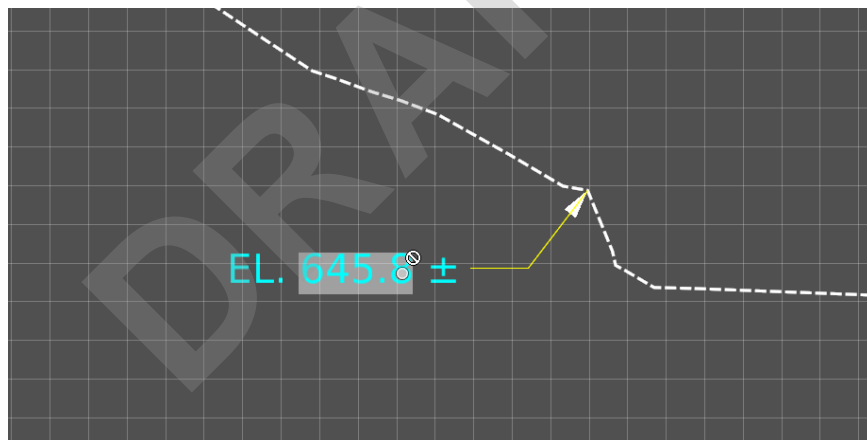

Use the Roadway Civil Labeler tools to get horizontal and vertical curve data on the plan sheet.

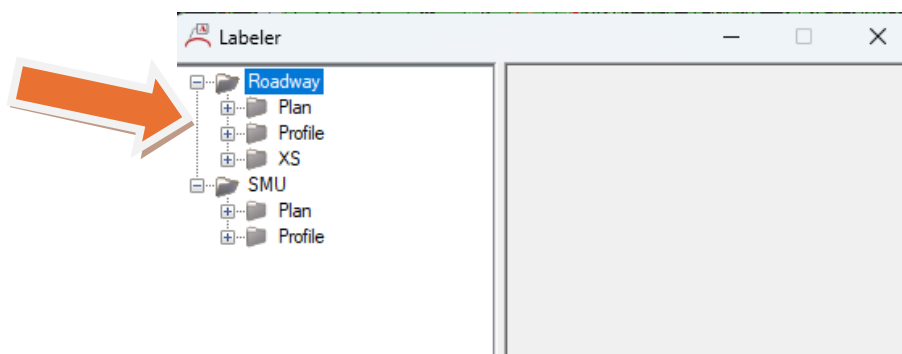

6.2 GENERAL DRAWING SHEETS

The process in the above section for creating the Preliminary General Drawing (PGD) should be used to create the General Drawing, following the guidelines in Chapter 5 of the *NCDOT Structures Management Design Manual* for differences in content requirements.

6.2.1 Foundation Layout Sheet

After the 3D Model DGN has been completed, create the DGN file for the Foundation Layout.

In the Foundation Layout DGN, go to the **Home tab > Primary ribbon > Attach Tools > References** find and attach the 3D Model DGN files for the project as a reference.

Once the 3D Model DGN is attached, close **View 2**, and in the **View 1** plan view, add workpoints to the alignment using the steps found in Section 3.8.2.1 if they are not already on the referenced 3D Model. Turn off any references and levels not needed.

Use the workpoints placed to locate and draw the foundations 1:1 in their geospatially correct locations.

To create the Drawing and Sheet models, in the **View 1** window, select the **Place Named Boundary tool > Civil Plan**.

Select the following:

- Drawing Seed: Design (or PRR) Standard View
- Detail Scale: select a scale that will encompass the structure in the plan view.

Tip: change the detail scale and check the length value compared to the bridge length, the length should be long enough to include the entire bridge, the approach slabs, plus some approach roadway on each end of the bridge.

- Boundary Chords: set the boundary chords to 1 to place only one boundary or the minimum number of boundaries required to fit the entire bridge to look correct on a plan sheet.
- Create Drawing: CHECKED

To place the plan sheet in View 1, select the alignment ahead of the bridge. The outline of the plan sheet should appear, if the box does not encompass the entire bridge and approaches as desired right click to cancel the placement. If the outline of the plan sheet encompasses the desired view, click ahead station to place it. Take note of the detail scale selected, it will be needed in further steps.

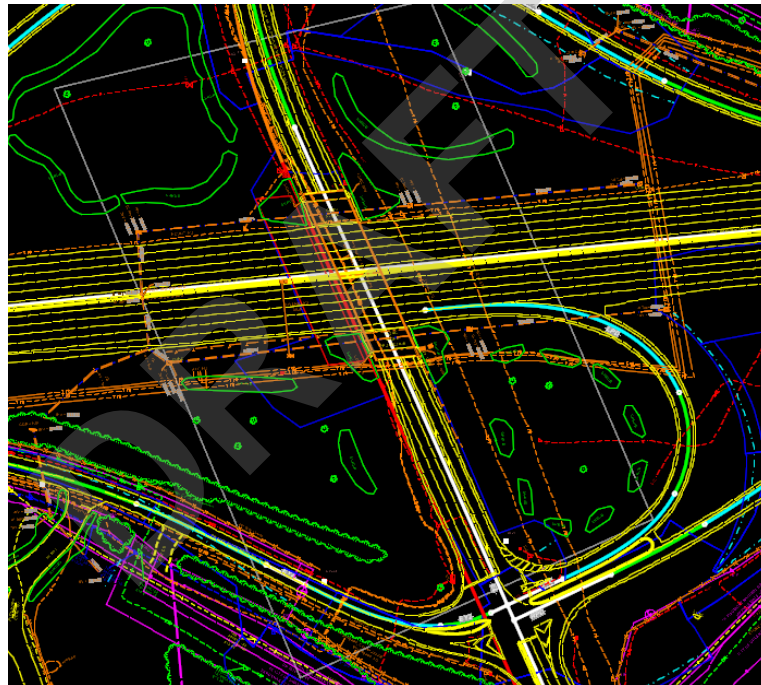

Note the Place Named Boundary tool might not open during this step, to open it click again within the boundary box.

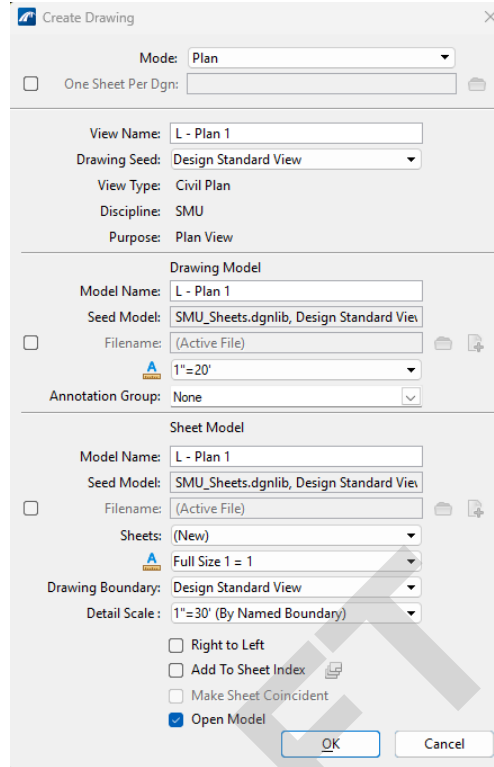

Note the plan view might generate larger than wanted onto the plan sheet, the size can be rescaled using the reference tool box.

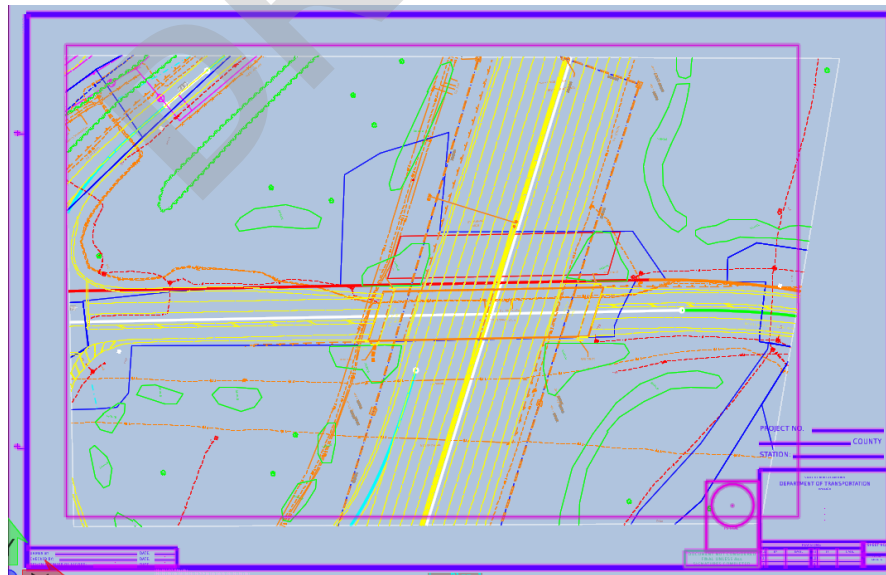

Use the Drawing Model to annotate the drawing. Notes are placed in the Sheet Model.

6.2.2 Long Chord Layout Sheet

After the 3D Model DGN has been completed, create the DGN file for the Foundation Layout.

In the Foundation Layout DGN, go to the **Home tab > Primary ribbon > Attach Tools > References** find and attach the 3D Model DGN files for the project as a reference.

Once the 3D Model DGN is attached, close **View 2**, and in the **View 1** plan view, add workpoints to the alignment using the steps found in Section 3.8.2.1 if they are not already on the referenced 3D Model. Turn off any references and levels not needed.

Use the workpoints placed to locate and draw the long & short chords at 1:1 in their geospatially correct locations.

To create the Drawing and Sheet models, in the **View 1** window, select the **Place Named Boundary tool > Civil Plan**.

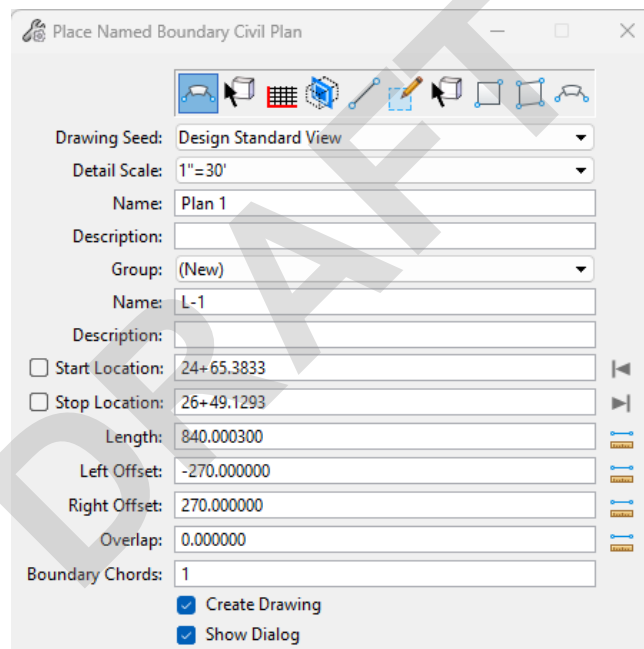

Select the following:

- Drawing Seed: Design (or PRR) Standard View
- Detail Scale: select a scale that will encompass the structure in the plan view.
 Tip: change the detail scale and check the length value compared to the bridge length, the length should be long enough to include the entire bridge, the approach slabs, plus some approach roadway on each end of the bridge.
- Boundary Chords: set the boundary chords to 1 to place only one boundary or the minimum number of boundaries required to fit the entire bridge to look correct on a plan sheet.

- Create Drawing: CHECKED

To place the plan sheet in View 1, select the alignment ahead of the bridge. The outline of the plan sheet should appear, if the box does not encompass the entire bridge and approaches as desired right click to cancel the placement. If the outline of the plan sheet encompasses the desired view, click ahead station to place it. Take note of the detail scale selected, it will be needed in further steps.

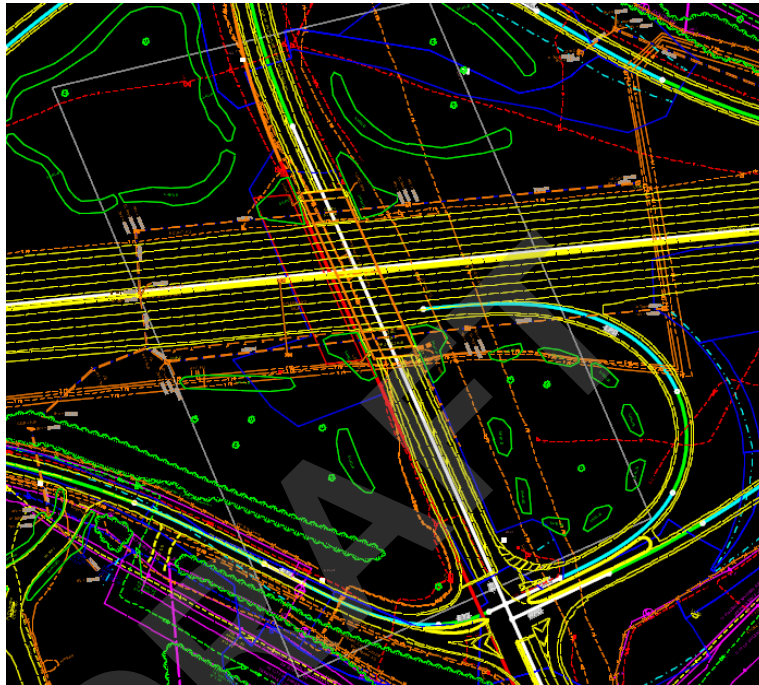

Note the Place Named Boundary tool might not open during this step, to open it click again within the boundary box.

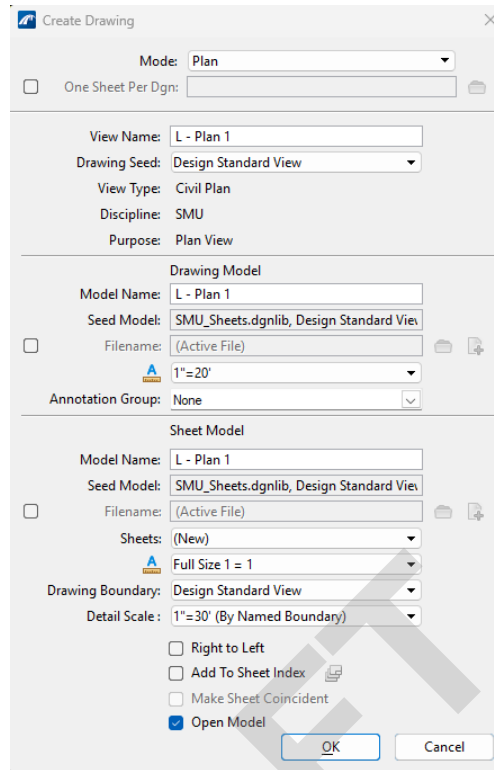

Note the plan view might generate larger than wanted onto the plan sheet, the size can be rescaled using the reference tool box.

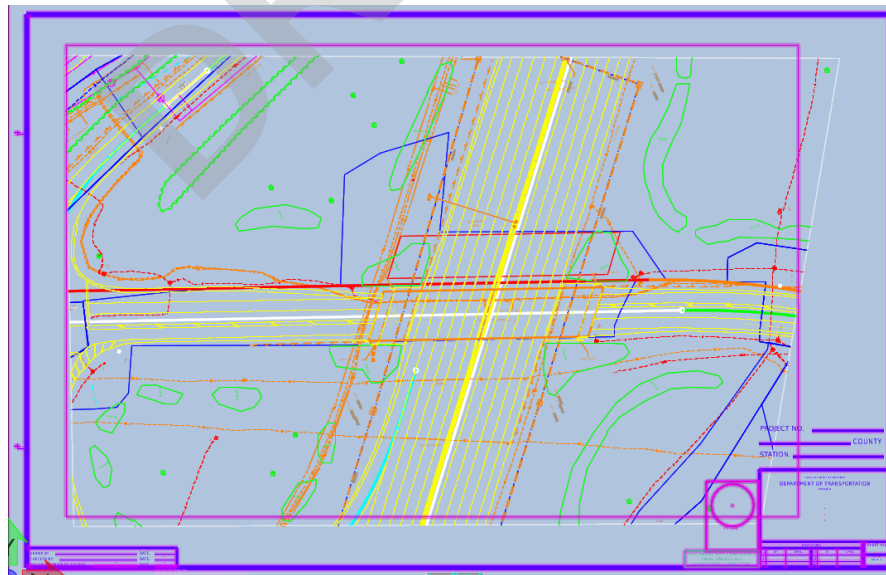

Use the Drawing Model to annotate the drawing. Notes are placed in the Sheet Model.

6.2.3 Location Sketch/Total Bill of Material Sheet

For location sketch and Total Bill of Material sheet requirements, see the guidelines in Chapter 5 of the *NCDOT Structures Management Design Manual*.

6.2.3.1 Location Sketch

Design

After the 3D Model DGN has been completed, create the DGN file for the Location Sketch.

In the Location Sketch DGN, go to the **Home tab > Primary ribbon > Attach Tools > References** find and attach the 3D Model DGN files for the project as a reference.

To create the Drawing and Sheet models, in the **View 1** window, select the **Place Named Boundary tool > Civil Plan**.

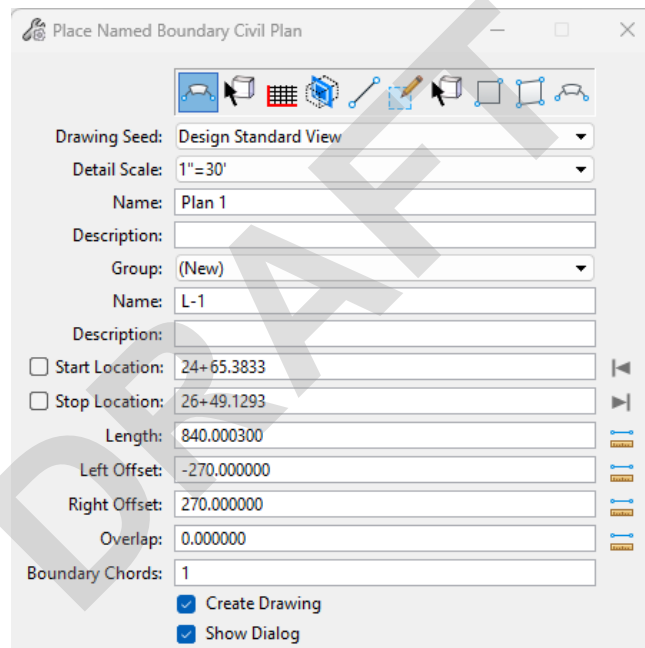

Select the following:

- Drawing Seed: Design (or PRR) Standard View
- Detail Scale: select a scale that will encompass the structure in the plan view.

Tip: change the detail scale and check the length value compared to the bridge length, the length should be long enough to include the entire bridge, the approach slabs, plus some approach roadway on each end of the bridge.
- Boundary Chords: set the boundary chords to 1 to place only one boundary or the minimum number of boundaries required to fit the entire bridge to look correct on a plan sheet.

- Create Drawing: CHECKED

To place the plan sheet in View 1, select the alignment ahead of the bridge. The outline of the plan sheet should appear, if the box does not encompass the entire bridge and approaches as desired right click to cancel the placement. If the outline of the plan sheet encompasses the desired view, click ahead station to place it. Take note of the detail scale selected, it will be needed in further steps.

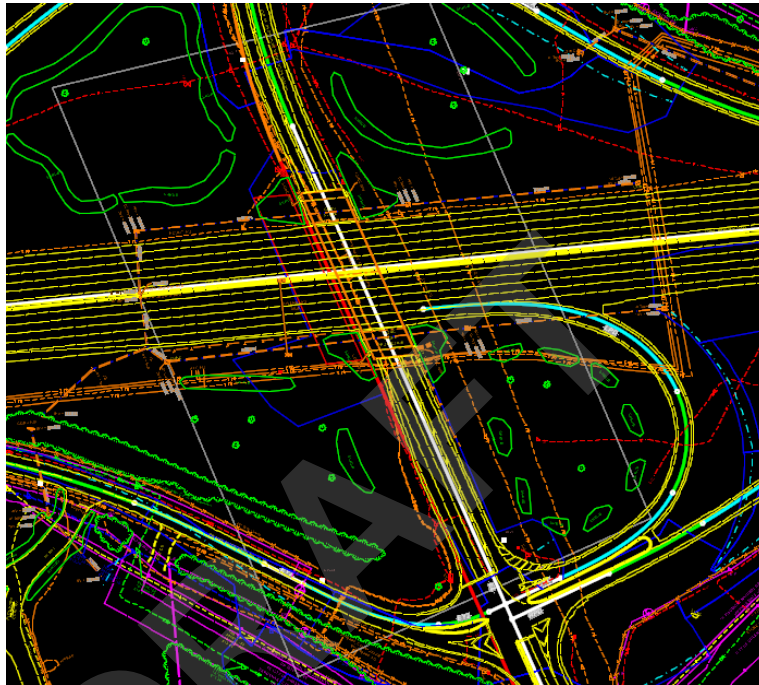

Note the Place Named Boundary tool might not open during this step, to open it click again within the boundary box.

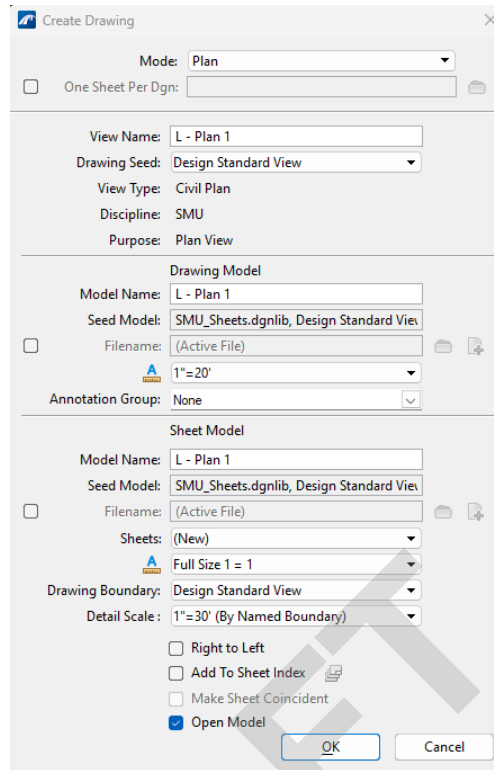

Note the location sketch might generate larger than wanted onto the plan sheet, the size can be rescaled using the reference tool box. Be sure to update the drawing scale in the Drawing Model to match the scale the reference in the Sheet Model is set to.

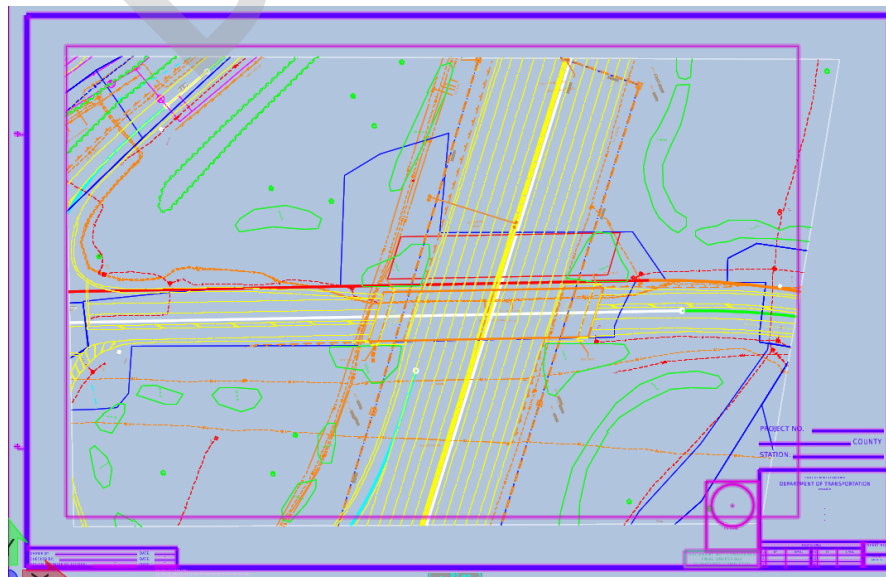

To get the Benchmark, go to the project folder on SharePoint, under the Location and Surveys folder Survey Controls subfolder, look for the Baseline or Control Sheets PDF or .txt files. These documents contain the survey data, including the Benchmarks (BM).

To place a Total Bill of Material table on the sheet, see Section 5.2.3.2 below.

Preservation

Preservation projects often don't have either Roadway or survey files to reference in the existing bridge sounding area. To get a location sketch and provide enough information to help the Contractor see what the surrounding conditions look like at the bridge, use [NCDOT's GO!NC](#) map viewer website with a hybrid view showing both road labels and satellite imagery. Take a clip of the bridge and surrounding image creating a .jpg file to be referenced.

Use the Raster Manager tool to insert the .jpg image into the sheet model.

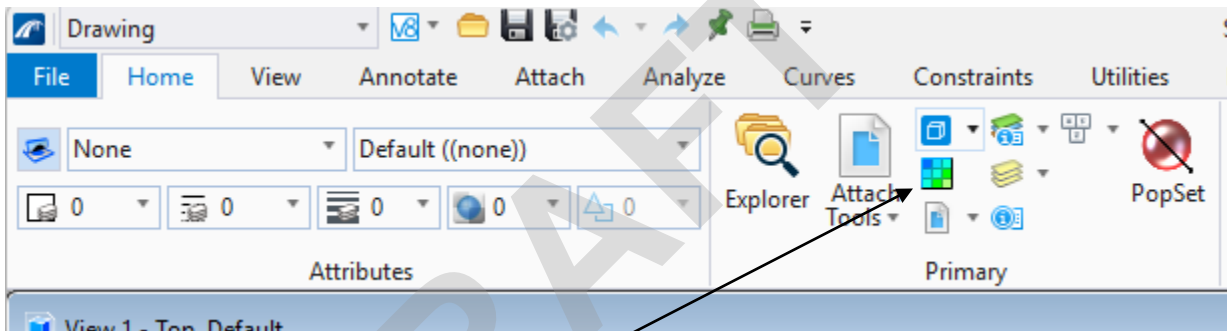

Raster Manager

File > Attach > Raster

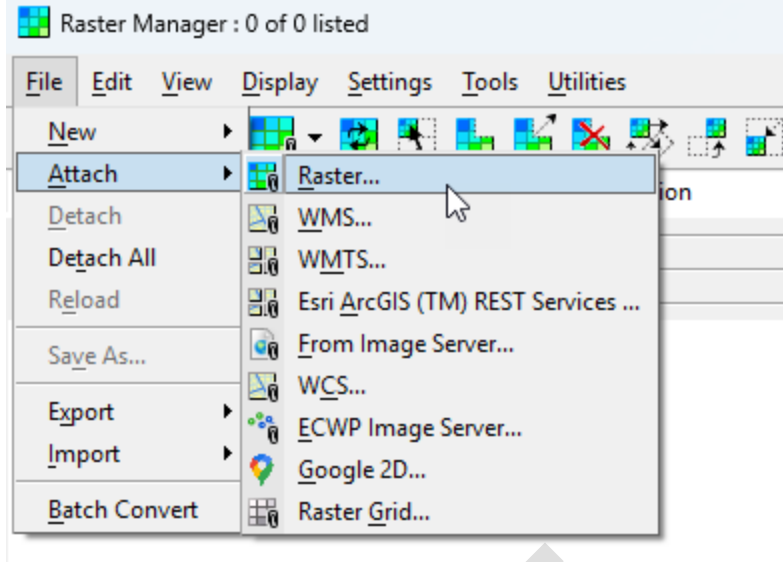

Locate the .jpg file created, click Open.

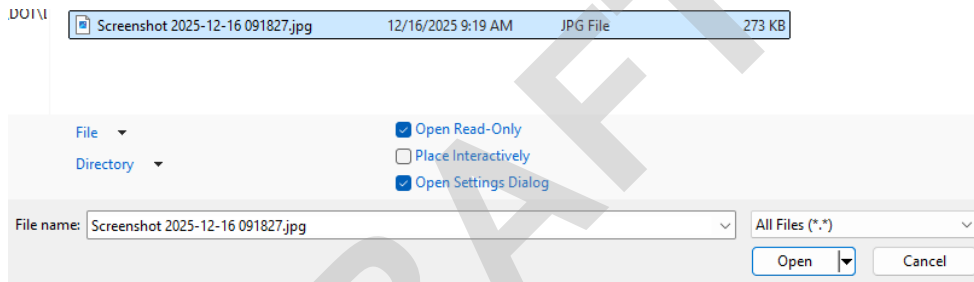

Check Raster Attachment Options, and click Attach.

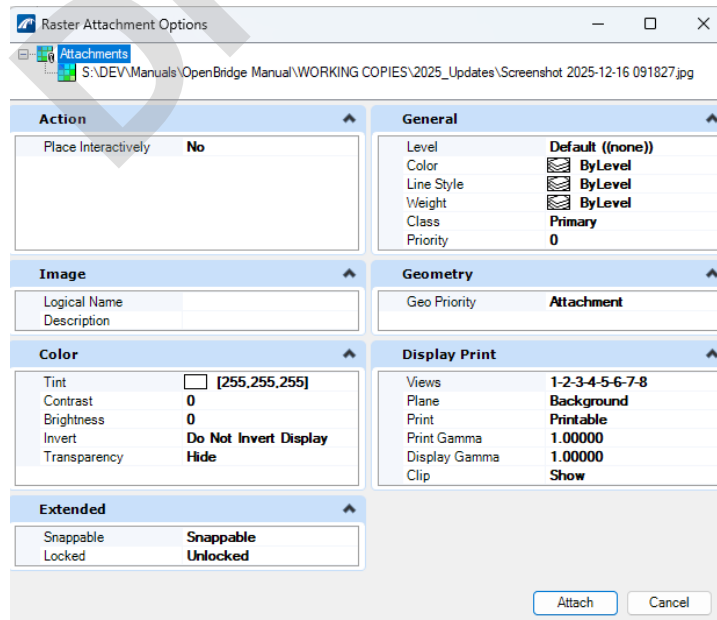

Move the Raster image as needed, the image can be selected allowing increasing or decreasing the size by selected and dragging the corners diagonally.



Place text using the annotation tools.

Provide the bridge coordinates using the Latitude and Longitudes from the structure inspection report.

To place a Total Bill of Material table on the sheet, see Section 5.2.3.2 below.

6.2.3.2 Total Bill of Material

Insert a Total Bill of Material using the Place Table tool.

Drawing Production > Tables > Place Table

Under the Seed dropdown, find the SMU_TBOM table seed

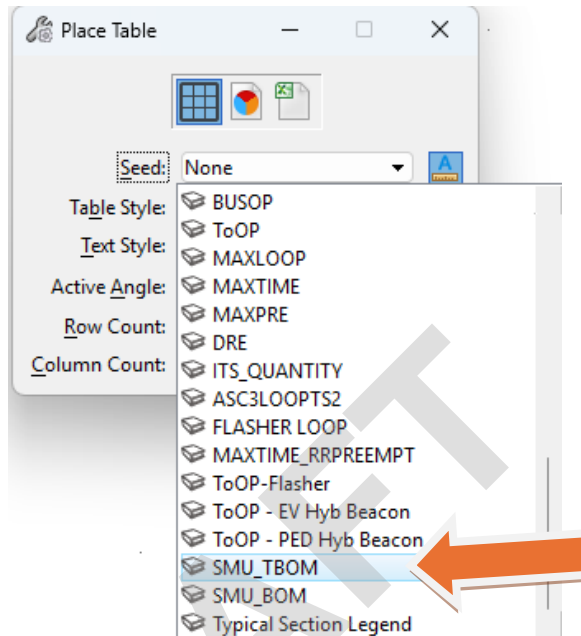

Edit the required number of columns to the number of pay items plus one to include the component name.

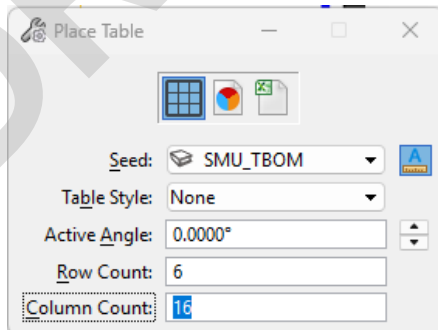

Place the table on the sheet border.



To edit the table, select it which will open up the excel format within the DGN. Edit as an excel table, use the excel tools on the Layout tab.

	A	B	C	D	E	F
1						
2		REMOVAL OF EXISTING STRUCTURE				
3		LUMP SUM				
4	BRIDGE No.					
5						
6	SUPERSTRUCTURE					
7	END BENT 1					
8						
9						
10	TOTAL					

Note the font will be set to correct style and levels, do not edit it.

6.3 GEOTECHNICAL FOUNDATION TABLE SHEETS

Geotech provides foundation recommendations in an Excel spreadsheet format where the data is included in tables on one single sheet or multiple sheets depending on the size of the structure. The purpose of this section is to show how to incorporate these tables into a DGN file to be included in the structure plan set.

5.3.1 Foundation Tables Excel File

Once the Excel file has been received from GEU and saved in the project folder, open the file, to identify which table tab(s) have been used for the recommendations and will need to be incorporated into the DGN file.. Most likely it will look like the sheet below.

The screenshot displays an Excel spreadsheet with several data tables. The tables are organized into sections: 'SUMMARY OF PILE INFORMATION/INSTALLATION', 'SUMMARY OF PDA/PILE ORDER LENGTHS', 'PILE DESIGN INFORMATION', 'SUMMARY OF DRILLED PIER INFORMATION/INSTALLATION', and 'SUMMARY OF DRILLED PIER TESTING'. Each table contains columns for various parameters such as pile identification, resistance values, dimensions, and testing outcomes. The spreadsheet also includes a 'NOTES' section at the bottom left and a project information block at the bottom right, including project number, county, and stationing.

5.3.2 Turn Off the Gridlines

In the Excel file, go to the View menu, uncheck Gridlines so it doesn't show when the spreadsheet is imported into OBD.

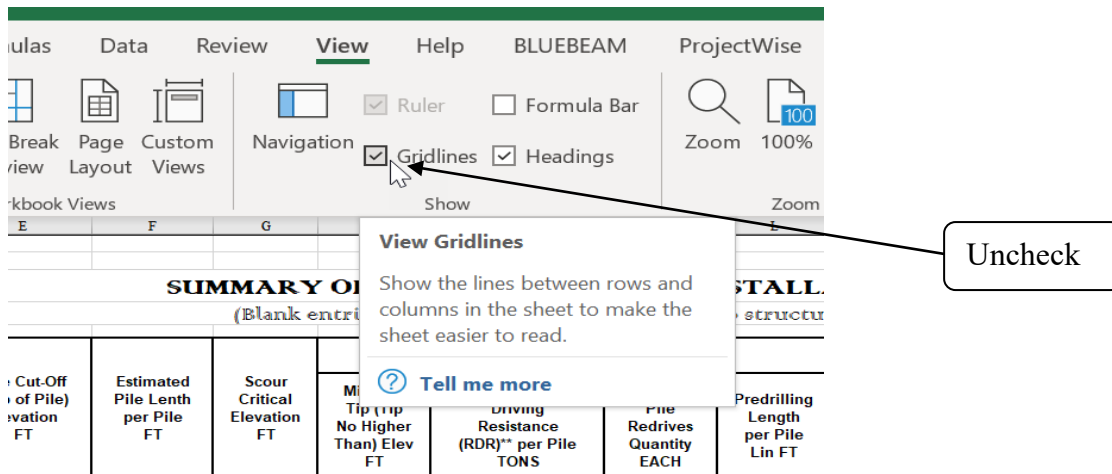

5.3.3 Link Spreadsheet Into The OBD File

Create or open the 4XX_###_TIP#_SMU_FT##_Sheet#_6digitStrID DGN file following Chapter 2.

6.3.4 Setting Up the DGN

Once the DGN is created and saved in the correct folder, open the DGN and open the “Models” dialog box.

Create a new sheet model and add the appropriate plan sheet border as described in Section 5.4.

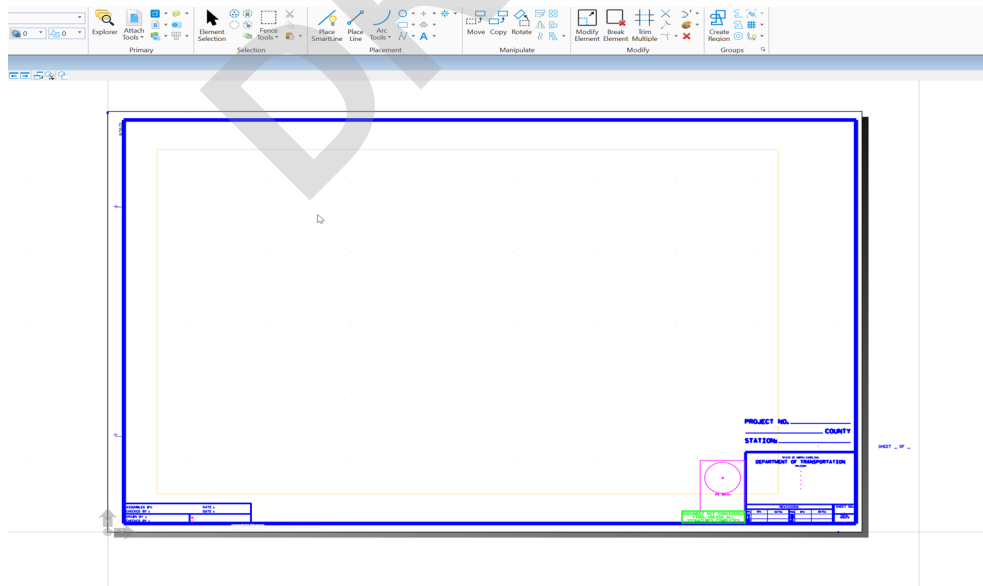

5.3.5 Copy from The Excel File

In the Excel file, select the tables from the spreadsheet.

SUMMARY OF PDA/PILE ORDER LENGTHS (Blank entries indicate items is not applicable to structure)																		
End Bent/ Bent No. Pile(s) # I.D., "Bent 1, Piles 1,2"		Factored Resistance per Pile TONS	Estimated Pile Length per Pile FT	Scour Critical Elevation FT	Min Pile Tip (To No-Higher Than) Elev FT	Required Driving Resistance (RDR) per Pile TONS	Total Pile Resilience Quantity EQ/CL	Predrilling Length per Pile Lin FT	Predrilling Elevation Elev (Not to Pre-drill Below) FT	Maximum Predrilling Diameter INCHES	Pre- Excavation Station of Hole Elev FT	Pre- Excavation Station of Hole Elev FT	Pre- Excavation Station of Hole Elev FT	Pre- Excavation Station of Hole Elev FT	Pre- Excavation Station of Hole Elev FT	Pre- Excavation Station of Hole Elev FT	Pre- Excavation Station of Hole Elev FT	
END BENT 1 Piles 1,2	100	800.00	30			750	0											
END BENT 2 Piles 1,2	100	800.00	30			750	0											

Predrilling for Piles is required for end bents with a predrilling length and at the Contractor's option for end bents with predrilling information but no predrilling length.
 $RDR = \text{Factored Resistance} \times \text{Factor of Downdrag Load} = \text{Factored Dead Load} \times \text{Nominal Scour Resistance} \times \text{Scour Resistance Factor}$

SUMMARY OF PDA/PILE ORDER LENGTHS (Blank entries indicate items is not applicable to structure)																		
End Bent/ Bent No. Pile(s) # I.D., "Bent 1, Piles 1,2"		Factored Resistance per Pile TONS	Estimated Pile Length per Pile FT	Scour Critical Elevation FT	Min Pile Tip (To No-Higher Than) Elev FT	Required Driving Resistance (RDR) per Pile TONS	Total Pile Resilience Quantity EQ/CL	Predrilling Length per Pile Lin FT	Predrilling Elevation Elev (Not to Pre-drill Below) FT	Maximum Predrilling Diameter INCHES	Pre- Excavation Station of Hole Elev FT	Pre- Excavation Station of Hole Elev FT	Pre- Excavation Station of Hole Elev FT	Pre- Excavation Station of Hole Elev FT	Pre- Excavation Station of Hole Elev FT	Pre- Excavation Station of Hole Elev FT	Pre- Excavation Station of Hole Elev FT	
END BENT 1 Piles 1,2	100	800.00	30			750	0											
END BENT 2 Piles 1,2	100	800.00	30			750	0											

*S1 - Pile order lengths from estimated pile lengths, PSA - Pile order lengths based on PSA testing. For groups of end bents with pile order lengths based on PSA testing, the first end bent is based on test for each group in the representation and bent with the PSA.

SUMMARY OF PDA/PILE ORDER LENGTHS (Blank entries indicate items is not applicable to structure)																		
End Bent/ Bent No. Pile(s) # I.D., "Bent 1, Piles 1,2"		Factored Resistance per Pile TONS	Estimated Pile Length per Pile FT	Scour Critical Elevation FT	Min Pile Tip (To No-Higher Than) Elev FT	Required Driving Resistance (RDR) per Pile TONS	Total Pile Resilience Quantity EQ/CL	Predrilling Length per Pile Lin FT	Predrilling Elevation Elev (Not to Pre-drill Below) FT	Maximum Predrilling Diameter INCHES	Pre- Excavation Station of Hole Elev FT	Pre- Excavation Station of Hole Elev FT	Pre- Excavation Station of Hole Elev FT	Pre- Excavation Station of Hole Elev FT	Pre- Excavation Station of Hole Elev FT	Pre- Excavation Station of Hole Elev FT	Pre- Excavation Station of Hole Elev FT	
END BENT 1 Piles 1,2	100	800.00	30			750	0											
END BENT 2 Piles 1,2	100	800.00	30			750	0											

Factored Dead Load is factored weight of pile above the ground line.

SUMMARY OF DRILLED PIER INFORMATION/INSTALLATION (Blank entries indicate items is not applicable to structure)																		
End Bent/ Bent No. Pile(s) # I.D., "Bent 1, Piles 1,2"		Factored Resistance per Pile TONS	Estimated Pile Length per Pile FT	Scour Critical Elevation FT	Min Pile Tip (To No-Higher Than) Elev FT	Required Driving Resistance (RDR) per Pile TONS	Total Pile Resilience Quantity EQ/CL	Predrilling Length per Pile Lin FT	Predrilling Elevation Elev (Not to Pre-drill Below) FT	Maximum Predrilling Diameter INCHES	Pre- Excavation Station of Hole Elev FT	Pre- Excavation Station of Hole Elev FT	Pre- Excavation Station of Hole Elev FT	Pre- Excavation Station of Hole Elev FT	Pre- Excavation Station of Hole Elev FT	Pre- Excavation Station of Hole Elev FT	Pre- Excavation Station of Hole Elev FT	
END BENT 1 Piles 1,2	100	800.00	30			750	0											
END BENT 2 Piles 1,2	100	800.00	30			750	0											

Permanent Steel Casting Length equals the difference between the ground line or top of drilled pier elevation, whichever is higher, and the permanent casting pier elevation.

SUMMARY OF DRILLED PIER TESTING (Blank entries indicate items is not applicable to structure)																		
End Bent/ Bent No. Pile(s) # I.D., "Bent 1, Piles 1,2"		Factored Resistance per Pile TONS	Estimated Pile Length per Pile FT	Scour Critical Elevation FT	Min Pile Tip (To No-Higher Than) Elev FT	Required Driving Resistance (RDR) per Pile TONS	Total Pile Resilience Quantity EQ/CL	Predrilling Length per Pile Lin FT	Predrilling Elevation Elev (Not to Pre-drill Below) FT	Maximum Predrilling Diameter INCHES	Pre- Excavation Station of Hole Elev FT	Pre- Excavation Station of Hole Elev FT	Pre- Excavation Station of Hole Elev FT	Pre- Excavation Station of Hole Elev FT	Pre- Excavation Station of Hole Elev FT	Pre- Excavation Station of Hole Elev FT	Pre- Excavation Station of Hole Elev FT	
END BENT 1 Piles 1,2	100	800.00	30			750	0											
END BENT 2 Piles 1,2	100	800.00	30			750	0											

*CSL Tables are required if CSL Testing is or may be required. The number of CSL Tables per drilled pier is equal to one table per foot of design pier diameter with at least 4 tables per pier. The length of each CSL Table is equal to the drilled pier length plus 5 ft.

PROJECT NO: BR-2004
 COUNTY: ROCKINGHAM
 STATION: 20+38.70 -L-

NOTES:
 1. The Pile and Drilled Pier Foundation Tables are based on the bridge substructure design and foundation recommendations sealed by a North Carolina Professional Engineer (Robert Lawrence, PE 054056) on 08-15-2022.
 2. Total Pile Driving Equipment Setup quantity (not shown in Pile Foundation Tables) equals the number of driven piles, i.e., the number of piles with a Required Driving Resistance.
 3. The Engineer will determine the need for PDA Testing, Permanent Steel Casting, SPTs, CSL Testing, SID Inspections and PITs when these items may be required.

STATE OF NORTH CAROLINA
 DEPARTMENT OF TRANSPORTATION
 DIVISION OF BRIDGE ENGINEERING

PROJECT NO: BR-2004
 COUNTY: ROCKINGHAM
 STATION: 20+38.70 -L-

PILE AND DRILLED PIER FOUNDATION TABLES

DATE: 08/15/2022
 SHEET NO: 3
 TOTAL SHEETS: 4

SUMMARY OF PILE INFORMATION/INSTALLATION
(blank entries indicate item is not applicable to structure)

End Bent/ Bent No., Pile(s) # & (e.g., "Bent 1, Piles 1-3")	Factored Resistance per Pile TONS	Pile Cut Off (Top of Pile) Elevation FT	Estimated Pile Length per Pile FT	Scour Critical Elevation FT	Driven Piles			Predrilling for Piles*			Drilled In Piles			
					Min. Pile Tip (No Higher Than Elev.) FT	Required Driving Resistance (RDR) ¹ per Pile TONS	Total Pile Reduces Quantity EACH	Predrilling Length per Pile Lin FT	Predrilling Elevation (Elev. No. To Predrill Below) FT	Maximum Predrilling Dia. INCHES	Pile Exc. Excavation (Bottom of Hole) Elev. FT	Pile Exc. Not In Soil per Pile Lin FT	Pile Exc. In Soil per Pile Lin FT	
END BENT 1 Piles 1-3	125	86.96	50			210	0							
END BENT 2 Piles 1-3	125	80.21	30			210								

*Predrilling for Piles is required for end bents/beams with a predrilling length and at the Contractor's option for end bents/beams with predrilling information but no predrilling length.

PILE DESIGN INFORMATION
(blank entries indicate item is not applicable to structure)

End Bent/ Bent No., Pile(s) # & (e.g., "Bent 1, Piles 1-3")	Factored Actual Load per Pile TONS	Factored Downdrag Load per Pile TONS	Factored Dead Load per Pile TONS	Dynamic Resistance Factor	Nominal Downdrag Resistance per Pile TONS	Nominal Scour Resistance per Pile TONS	Scour Resistance Factor (Default = 1.00)
END BENT 1 Piles 1-3	123.5			0.50			1.00
END BENT 2 Piles 1-3	123.5			0.50			1.00

*Factored Dead Load is factored weight of pile above the ground line.

SUMMARY OF DRILLED PIER INFORMATION/INSTALLATION
(blank entries indicate item is not applicable to structure)

End Bent/ Bent No., Pile(s) # & (e.g., "Bent 1, Piles 1-3")	Factored Resistance per Pier TONS	Minimum Pier Tip Resistance (Tip No. Higher Than) Elevation FT	Required Pier Resistance per Pier TSF	Scour Critical Elevation FT	Minimum Drilled Pier Penetration into Rock per Pier Lin FT	Drilled Pier Length per Pier Lin FT	Drilled Pier Length No. In Soil per Pier Lin FT	Drilled Pier Length In Soil per Pier Lin FT	Permanent Steel Casing Required? YES or MAYBE	Permanent Steel Casing Tip Elevation (Elev. No. To Extend Casing Below) FT
BENT 1, Piles 1-3	666	760.0	30			27.0	10.0	17.0		

*Permanent Steel Casing Length equals the difference between the ground line or top of drilled pier elevation, whichever is higher, and the permanent casing tip elevation.

SUMMARY OF PDA/PILE ORDER LENGTHS
(Blank entries indicate item is not applicable to structure)

End Bent/ Bent No.	PDA Testing Required? YES or MAYBE		Total PDA Test Pile Length FT	Total PDA Testing Quantity EACH	Pile Order Lengths	
	End Bent/ Bent No(s)	Pile Order Length Units ¹ EST or PDA				
END BENT 1 Piles 1-3	MAYBE	55	1			
END BENT 2 Piles 1-3	MAYBE	35				

EST = Pile order lengths from estimated pile lengths. PDA = Pile order lengths based on PDA testing. For groups of end bents/beams with pile order lengths based on PDA testing, the first end bent/beam no. listed for each group is the reference with the PDA.

SUMMARY OF PILE ACCESSORIES
(blank entries indicate item is not applicable to structure)

# of Piles (e.g., 1, 2, 3, 4, 5, 6, 7, 8, 9, 10, 11, 12, 13, 14, 15, 16, 17, 18, 19, 20, 21, 22, 23, 24, 25, 26, 27, 28, 29, 30, 31, 32, 33, 34, 35, 36, 37, 38, 39, 40, 41, 42, 43, 44, 45, 46, 47, 48, 49, 50, 51, 52, 53, 54, 55, 56, 57, 58, 59, 60, 61, 62, 63, 64, 65, 66, 67, 68, 69, 70, 71, 72, 73, 74, 75, 76, 77, 78, 79, 80, 81, 82, 83, 84, 85, 86, 87, 88, 89, 90, 91, 92, 93, 94, 95, 96, 97, 98, 99, 100, 101, 102, 103, 104, 105, 106, 107, 108, 109, 110, 111, 112, 113, 114, 115, 116, 117, 118, 119, 120, 121, 122, 123, 124, 125, 126, 127, 128, 129, 130, 131, 132, 133, 134, 135, 136, 137, 138, 139, 140, 141, 142, 143, 144, 145, 146, 147, 148, 149, 150, 151, 152, 153, 154, 155, 156, 157, 158, 159, 160, 161, 162, 163, 164, 165, 166, 167, 168, 169, 170, 171, 172, 173, 174, 175, 176, 177, 178, 179, 180, 181, 182, 183, 184, 185, 186, 187, 188, 189, 190, 191, 192, 193, 194, 195, 196, 197, 198, 199, 200, 201, 202, 203, 204, 205, 206, 207, 208, 209, 210, 211, 212, 213, 214, 215, 216, 217, 218, 219, 220, 221, 222, 223, 224, 225, 226, 227, 228, 229, 230, 231, 232, 233, 234, 235, 236, 237, 238, 239, 240, 241, 242, 243, 244, 245, 246, 247, 248, 249, 250, 251, 252, 253, 254, 255, 256, 257, 258, 259, 260, 261, 262, 263, 264, 265, 266, 267, 268, 269, 270, 271, 272, 273, 274, 275, 276, 277, 278, 279, 280, 281, 282, 283, 284, 285, 286, 287, 288, 289, 290, 291, 292, 293, 294, 295, 296, 297, 298, 299, 300, 301, 302, 303, 304, 305, 306, 307, 308, 309, 310, 311, 312, 313, 314, 315, 316, 317, 318, 319, 320, 321, 322, 323, 324, 325, 326, 327, 328, 329, 330, 331, 332, 333, 334, 335, 336, 337, 338, 339, 340, 341, 342, 343, 344, 345, 346, 347, 348, 349, 350, 351, 352, 353, 354, 355, 356, 357, 358, 359, 360, 361, 362, 363, 364, 365, 366, 367, 368, 369, 370, 371, 372, 373, 374, 375, 376, 377, 378, 379, 380, 381, 382, 383, 384, 385, 386, 387, 388, 389, 390, 391, 392, 393, 394, 395, 396, 397, 398, 399, 400, 401, 402, 403, 404, 405, 406, 407, 408, 409, 410, 411, 412, 413, 414, 415, 416, 417, 418, 419, 420, 421, 422, 423, 424, 425, 426, 427, 428, 429, 430, 431, 432, 433, 434, 435, 436, 437, 438, 439, 440, 441, 442, 443, 444, 445, 446, 447, 448, 449, 450, 451, 452, 453, 454, 455, 456, 457, 458, 459, 460, 461, 462, 463, 464, 465, 466, 467, 468, 469, 470, 471, 472, 473, 474, 475, 476, 477, 478, 479, 480, 481, 482, 483, 484, 485, 486, 487, 488, 489, 490, 491, 492, 493, 494, 495, 496, 497, 498, 499, 500, 501, 502, 503, 504, 505, 506, 507, 508, 509, 510, 511, 512, 513, 514, 515, 516, 517, 518, 519, 520, 521, 522, 523, 524, 525, 526, 527, 528, 529, 530, 531, 532, 533, 534, 535, 536, 537, 538, 539, 540, 541, 542, 543, 544, 545, 546, 547, 548, 549, 550, 551, 552, 553, 554, 555, 556, 557, 558, 559, 560, 561, 562, 563, 564, 565, 566, 567, 568, 569, 570, 571, 572, 573, 574, 575, 576, 577, 578, 579, 580, 581, 582, 583, 584, 585, 586, 587, 588, 589, 590, 591, 592, 593, 594, 595, 596, 597, 598, 599, 600, 601, 602, 603, 604, 605, 606, 607, 608, 609, 610, 611, 612, 613, 614, 615, 616, 617, 618, 619, 620, 621, 622, 623, 624, 625, 626, 627, 628, 629, 630, 631, 632, 633, 634, 635, 636, 637, 638, 639, 640, 641, 642, 643, 644, 645, 646, 647, 648, 649, 650, 651, 652, 653, 654, 655, 656, 657, 658, 659, 660, 661, 662, 663, 664, 665, 666, 667, 668, 669, 670, 671, 672, 673, 674, 675, 676, 677, 678, 679, 680, 681, 682, 683, 684, 685, 686, 687, 688, 689, 690, 691, 692, 693, 694, 695, 696, 697, 698, 699, 700, 701, 702, 703, 704, 705, 706, 707, 708, 709, 710, 711, 712, 713, 714, 715, 716, 717, 718, 719, 720, 721, 722, 723, 724, 725, 726, 727, 728, 729, 730, 731, 732, 733, 734, 735, 736, 737, 738, 739, 740, 741, 742, 743, 744, 745, 746, 747, 748, 749, 750, 751, 752, 753, 754, 755, 756, 757, 758, 759, 760, 761, 762, 763, 764, 765, 766, 767, 768, 769, 770, 771, 772, 773, 774, 775, 776, 777, 778, 779, 780, 781, 782, 783, 784, 785, 786, 787, 788, 789, 790, 791, 792, 793, 794, 795, 796, 797, 798, 799, 800, 801, 802, 803, 804, 805, 806, 807, 808, 809, 810, 811, 812, 813, 814, 815, 816, 817, 818, 819, 820, 821, 822, 823, 824, 825, 826, 827, 828, 829, 830, 831, 832, 833, 834, 835, 836, 837, 838, 839, 840, 841, 842, 843, 844, 845, 846, 847, 848, 849, 850, 851, 852, 853, 854, 855, 856, 857, 858, 859, 860, 861, 862, 863, 864, 865, 866, 867, 868, 869, 870, 871, 872, 873, 874, 875, 876, 877, 878, 879, 880, 881, 882, 883, 884, 885, 886, 887, 888, 889, 890, 891, 892, 893, 894, 895, 896, 897, 898, 899, 900, 901, 902, 903, 904, 905, 906, 907, 908, 909, 910, 911, 912, 913, 914, 915, 916, 917, 918, 919, 920, 921, 922, 923, 924, 925, 926, 927, 928, 929, 930, 931, 932, 933, 934, 935, 936, 937, 938, 939, 940, 941, 942, 943, 944, 945, 946, 947, 948, 949, 950, 951, 952, 953, 954, 955, 956, 957, 958, 959, 960, 961, 962, 963, 964, 965, 966, 967, 968, 969, 970, 971, 972, 973, 974, 975, 976, 977, 978, 979, 980, 981, 982, 983, 984, 985, 986, 987, 988, 989, 990, 991, 992, 993, 994, 995, 996, 997, 998, 999, 1000	Pile PDA Testing Required? YES or MAYBE	Pile PDA Test Pile Length FT	Pile PDA Testing Quantity EACH	Steel Pile PDA Testing Required? YES or MAYBE	Steel Pile PDA Test Pile Length FT	Steel Pile PDA Testing Quantity EACH
	END BENT 1 Piles 1-3	MAYBE	55	1		
END BENT 2 Piles 1-3	MAYBE	35				

EST = Pile order lengths from estimated pile lengths. PDA = Pile order lengths based on PDA testing. For groups of end bents/beams with pile order lengths based on PDA testing, the first end bent/beam no. listed for each group is the reference with the PDA.

SUMMARY OF DRILLED PIER TESTING
(blank entries indicate item is not applicable to structure)

of Piles (e.g., 1, 2, 3, 4, 5, 6, 7, 8, 9, 10, 11, 12, 13, 14, 15, 16, 17, 18, 19, 20, 21, 22, 23, 24, 25, 26, 27, 28, 29, 30, 31, 32, 33, 34, 35, 36, 37, 38, 39, 40, 41, 42, 43, 44, 45, 46, 47, 48, 49, 50, 51, 52, 53, 54, 55, 56, 57, 58, 59, 60, 61, 62, 63, 64, 65, 66, 67, 68, 69, 70, 71, 72, 73, 74, 75, 76, 77, 78, 79, 80, 81, 82, 83, 84, 85, 86, 87, 88, 89, 90, 91, 92, 93, 94, 95, 96, 97, 98, 99, 100, 101, 102, 103, 104, 105, 106, 107, 108, 109, 110, 111, 112, 113, 114, 115, 116, 117, 118, 119, 120, 121, 122, 123, 124, 125, 126, 127, 128, 129, 130, 131, 132, 133, 134, 135, 136, 137, 138, 139, 140, 141, 142, 143, 144, 145, 146, 147, 148, 149, 150, 151, 152, 153, 154, 155, 156, 157, 158, 159, 160, 161, 162, 163, 164, 165, 166, 167, 168, 169, 170, 171, 172, 173, 174, 175, 176, 177, 178, 179, 180, 181, 182, 183, 184, 185, 186, 187, 188, 189, 190, 191, 192, 193, 194, 195, 196, 197, 198, 199, 200, 201, 202, 203, 204, 205, 206, 207, 208, 209, 210, 211, 212, 213, 214, 215, 216, 217, 218, 219, 220, 221, 222, 223, 224, 225, 226, 227, 228, 229, 230, 231, 232, 233, 234, 235, 236, 237, 238, 239, 240, 241, 242, 243, 244, 245, 246, 247, 248, 249, 250, 251, 252, 253, 254, 255, 256, 257, 258, 259, 260, 261, 262, 263, 264, 265, 266, 267, 268, 269, 270, 271, 272, 273, 274, 275, 276, 277, 278, 279, 280, 281, 282, 283, 284, 285, 286, 287, 288, 289, 290, 291, 292, 293, 294, 295, 296, 297, 298, 299, 300, 301, 302, 303, 304, 305, 306, 307, 308, 309, 310, 311, 312, 313, 314, 315, 316, 317, 318, 319, 320, 321, 322, 323, 324, 325, 326, 327, 328, 329, 330, 331, 332, 333, 334, 335, 336, 337, 338, 339, 340, 341, 342, 343, 344, 345, 346, 347, 348, 349, 350, 351, 352, 353, 354, 355, 356, 357, 358, 359, 360, 361, 362, 363, 364, 365, 366, 367, 368, 369, 370, 371, 372, 373, 374, 375, 376, 377, 378, 379, 380, 381, 382, 383, 384, 385, 386, 387, 388, 389, 390, 391, 392, 393, 394, 395, 396, 397, 398, 399, 400, 401, 402, 403, 404, 405, 406, 407, 408, 409, 410, 411, 412, 413, 414, 415, 416, 417, 418, 419, 420, 421, 422, 423, 424, 425, 426, 427, 428, 429, 430, 431, 432, 433, 434, 435, 436, 437, 438, 439, 440, 441, 442, 443, 444, 445, 446, 447, 448, 449, 450, 451, 452, 453, 454, 455, 456, 457, 458, 459, 460, 461, 462, 463, 464, 465, 466, 467, 468, 469, 470, 471, 472, 473, 474, 475, 476, 477, 478, 479, 480, 481, 482, 483, 484, 485, 486, 487, 488, 489, 490, 491, 492, 493, 494, 495, 496, 497, 498, 499, 500, 501, 502, 503, 504, 505, 506, 507, 508, 509, 510, 511, 512, 513, 514, 515, 516, 517, 518, 519, 520, 521, 522, 523, 524, 525, 526, 527, 528, 529, 530, 531, 532, 533, 534, 535, 536, 537, 538, 539, 540, 541, 542, 543, 544, 545, 546, 547, 548, 549, 550, 551, 552, 553, 554, 555, 556, 557, 558, 559, 560, 561, 562, 563, 564, 565, 566, 567, 568, 569, 570, 571, 572, 573, 574, 575, 576, 577, 578, 579, 580, 581, 582, 583, 584, 585, 586, 587, 588, 589, 590, 591, 592, 593, 594, 595, 596, 597, 598, 599, 600, 601, 602, 603, 604, 605, 606, 607, 608, 609, 610, 611, 612, 613, 614, 615, 616, 617, 618, 619, 620, 621, 622, 623, 624, 625, 626, 627, 628, 629, 630, 631, 632, 633, 634, 635, 636, 637,
--

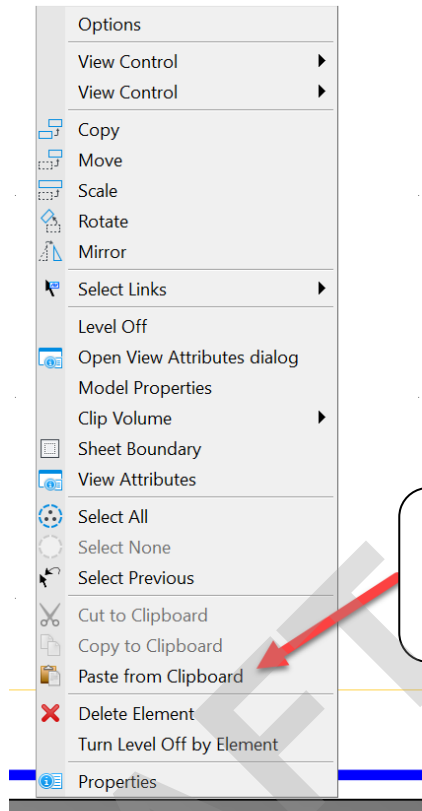

Right click and hold anywhere in the sheet to access this menu and choose to “Paste from Clipboard”.

Paste as shown below:

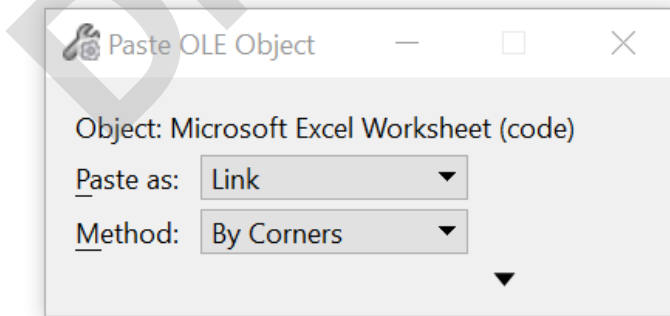

Make sure you select “Transparent Background”.

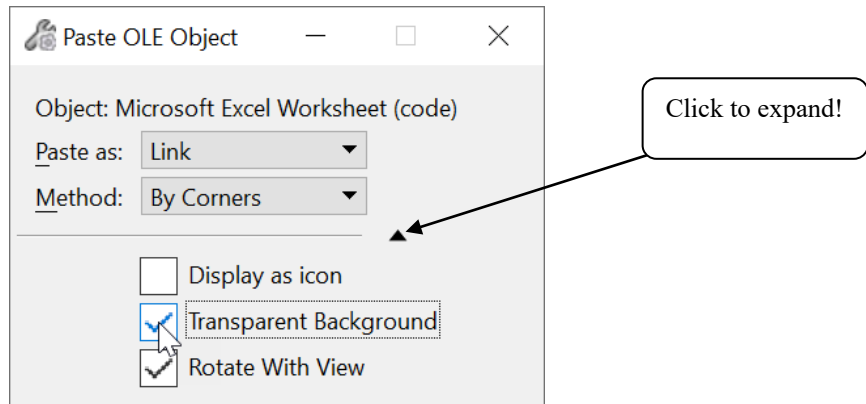

Place the tables by corners as shown below.

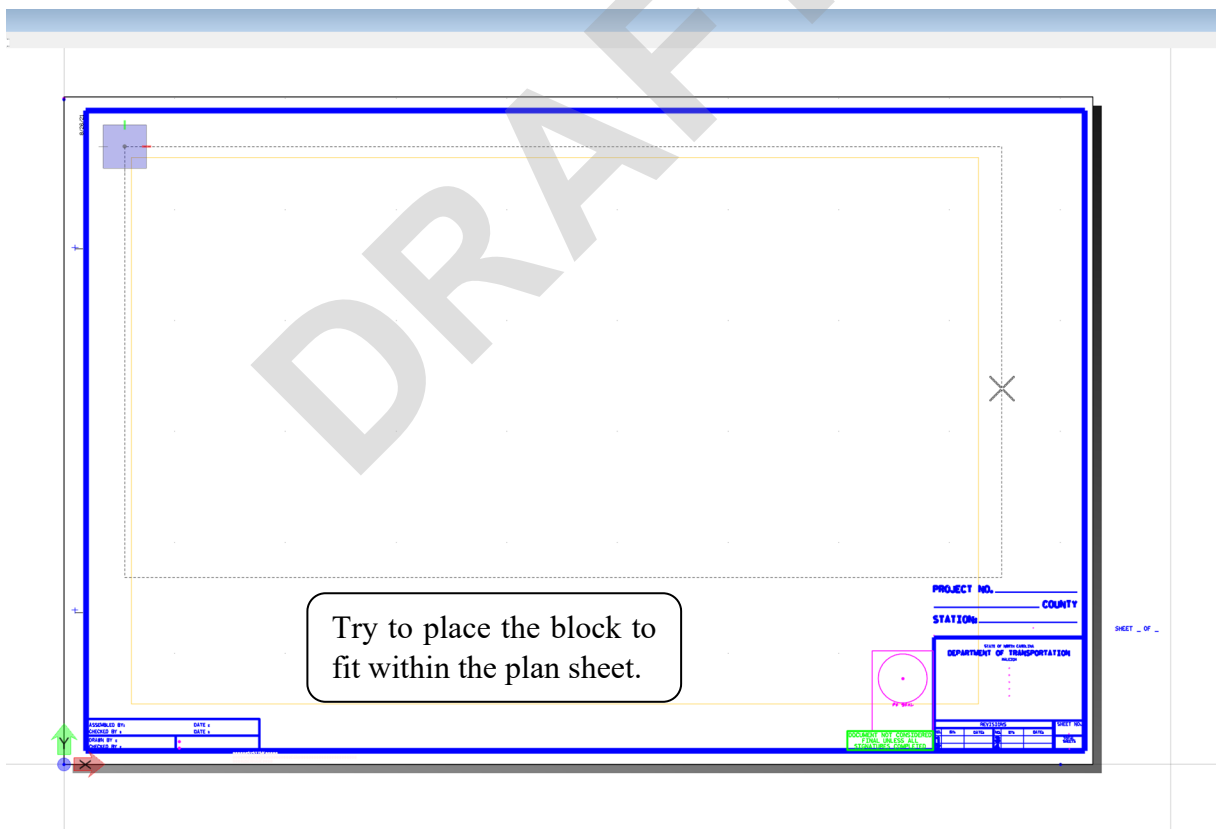

Copied tables are now linked.

5.3.7 Properties of the Linked Tables in OBD

Excel files linked in OBD will be live and can be updated to reflect any changes made in the original files. Follow the steps to update links in OBD:

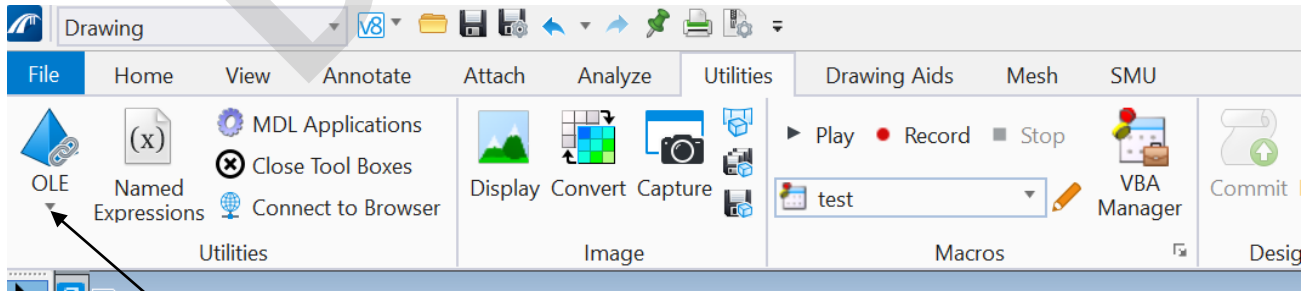

From the Utilities menu, click the drop-down list of OLE.

Click on "Update Links".

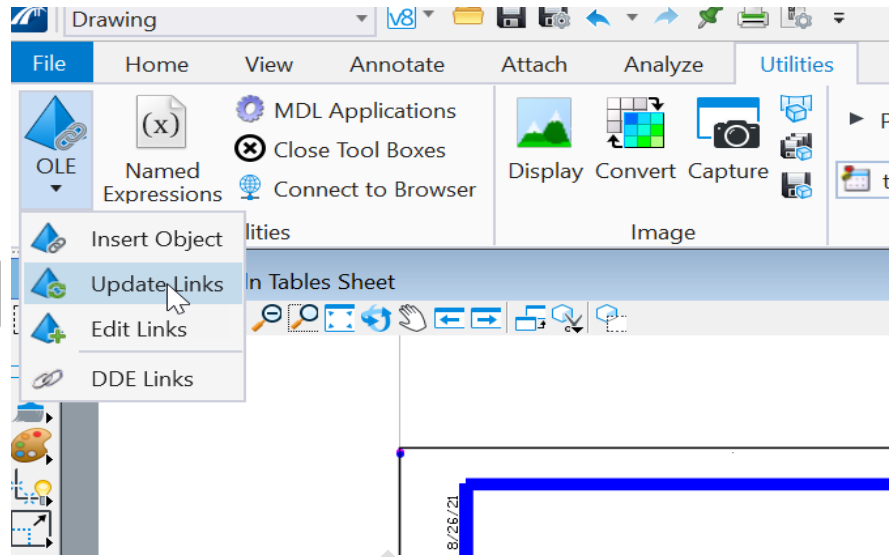

This action will update the values (cells) of the spreadsheet, but won't affect the properties or size of the linked tables.

Item No. Pile(s) # (e.g., "Bent 1, Piles 1-5")	Resistance per Pile TONS	(Top of Pile) Elevation FT	Pile Length per Pile FT	Critical Elevation FT	min r/w Tip (Tip No Higher Than) C/w FT	required Driving Resistance (RDR)** per Pile TONS	r/w Pile Redrives Quantity EACH	Predrilling Length per Pile Lin FT	Preloading Elevation (Elev Not To Prefill Below) FT	Maximum Predrilling Dia INCHES	r/w Excavation (Bottom of Hole) C/w FT	r/w Exc In Soil per Pile Lin FT	Pile Exc In Soil per Pile Lin FT
END BENT 1 Piles 1-8	125	866.95	50			210	0						
END BENT 2 Piles 1-8	125	863.21	30			210							

**Predrilling for Piles is required for end bents/bents with a predrilling length and at the Contractor's option for end bents/bents with predrilling information but no predrilling length.
**RDR = Factored Resistance + Factored Downdrag Load + Factored Dead Load + Nominal Downdrag Resistance + Nominal Scour Resistance

Dynamic Resistance Factor
Scour Resistance Factor
(Blank entries indicate item is not applicable to structure)

End Bent/ Bent No. Pile(s) # (e.g., "Bent 1, Piles 1-5")	Factored Axial Load per Pile TONS	Factored Downdrag Load per Pile TONS	Factored Dead Load per Pile TONS	Dynamic Resistance Factor	Nominal Downdrag Resistance per Pile TONS	Nominal Scour Resistance per Pile TONS	Scour Resistance Factor (Default = 1.0)
END BENT 1 Piles 1-8	125.5			0.60			1.00
END BENT 2 Piles 1-8	123.5			0.60			1.00
							1.00
							1.00

*Factored Dead Load is factored weight of pile above the ground line.

SUMMARY OF DRILLED PIER INFORMATION /INSTALLATION
(Blank entries indicate item is not applicable to structure)

End Bent/ Bent No. Pile(s) # (e.g., "Bent 1, Piles 1-3")	Factored Resistance per Pier TONS	Minimum Pier Tip (Tip No Higher Than) Elevation FT	Required Tip Resistance per Pier TSF	Scour Critical Elevation FT	Minimum Drilled Pier Penetration Into Rock per Pier Lin FT	Drilled Pier Length Not to Soil per Pier Lin FT	Drilled Pier Length In Soil per Pier Lin FT	Permanent Steel Casing Required? YES or MAYBE	Permanent Steel Casing Top Elevation (Elev Not to Extend Casing Below) FT	Permanent Steel Casing Length* per Pier Lin FT
BENT 1 Piles 1-3	605	750.0	30			27.0	50.0	17.0		

*Permanent Steel Casing Length equals the difference between the ground line or top of drilled pier elevation, whichever is higher, and the permanent casing tip elevation.

Link to: \\Dot\dfsroot01\Groups-SDCC\DEV\All Individual Folders\Samuel\OBD\Geotech Tables\NCDOT BRR NC770 Over US220 Geotechnical Foundation Tables 08-05-22.xlsm\Piles & Drilled Piers\R2C3:R67C31
Level: Default

Double click on the link border to open the linked Excel File.

End Bent/ Bent No.	PDA Testing Required? YES or MAYBE	PDA Test Pile Length FT	r/w PDA Testing Quantity EACH	End Bent/ Bent No(s)
END BENT 1 Piles 1-8	MAYBE	55	1	
END BENT 2 Piles 1-8	MAYBE	35		

*EST = Pile order lengths from estimated pile lengths; PDA = Pile order lengths based on PDA testing of end bents/bents with pile order lengths based on PDA testing, the first end bent/bent no. listed is the representative end bent/bent with the PDA.

SUMMARY OF PILE ACCESSORIES
(Blank entries indicate item is not applicable to structure)

End Bent/ Bent No. Pile(s) # (e.g., "Bent 1, Piles 1-5")	Pile Pile Piles Required? YES or MAYBE	Steel Pile Points			Steel Pile Tips Required? YES
		Pipe Pile Cutting Shoes Required? YES	Pipe Pile Conical Points Required? YES	H-Pile Points Required? YES	
END BENT 1 Piles 1-8					
END BENT 2 Piles 1-8				YES	
TOTAL QTY:				8	

SUMMARY OF DRILLED PIER TESTING
(Blank entries indicate item is not applicable to structure)

End Bent/ Bent No. Pile(s) # (e.g., "Bent 1, Piles 1-3")	Standard Penetration Test (SPT) Required? YES or MAYBE	Crosshole Sonic Logging (CSL) Required? YES or MAYBE	Total CSL Tube Length (For All Tubes) per Pier Lin FT	Shaft Inspection Device (SID) Required? YES or MAYBE	Pile Integ Test (PIT) Require MAYE
BENT 1 Piles 1-3	YES	MAYBE	108	NO	NO
TOTAL QTY:	3		324		

*CSL Tubes are required if CSL Testing is or may be required. The number of CSL Tubes per drilled is equal to one tube per foot of design pier diameter with at least 4 tubes per pier. The length of each Tube is equal to the drilled pier length plus 1.5 ft.

PROJEC
STATIC
DEPA

5.3.8 Multiple Links

You may link different tables or notes from separate spreadsheets on the same plan sheet.

SUMMARY OF PILE INFORMATION/INSTALLATION
(Blank entries indicate item is not applicable to structure)

End Bent Bent No. Plan/Profile # E.g., Sheet 1, Plan 1.57	Factored Resistance per Pile TONS	Pile Cap Off (Top of Pile) Elevation FT	Estimated Pile Length per Pile FT	Score Critical Elevation FT	Driven Piles			Preloading for Piles*			Drilled-In Piles				
					Min Pile Tip Elev No Higher Than Elev FT	Required Driving Resistance (RDR) per Pile TONS	Total Pile Resistance per Pile TONS	Preloading Length per Pile Lin FT	Preloading Change (Elev Not to Exceed Below) FT	Maximum Preloading Dia INCHES	Pile Exc N/A In Soil per Pile Lin FT	Pile Exc In Soil per Pile Lin FT	Pile Order Lengths EST or PCA		
END BENT 1 Pile 1.8	50	800.56	50		270	0									
END BENT 2 Pile 1.8	50	803.21	50		270	0									

*Preloading for Piles is required for end bents with a preloading length and at the Contractor's option for end bents with preloading information but no preloading length.
#DR = Factored Resistance / Factored Driving Load / Factored Dead Load / Nominal Driving Resistance / Nominal Score Resistance / Score Resistance Factor

SUMMARY OF PDA/PILE ORDER LENGTHS
(Blank entries indicate item is not applicable to structure)

Pile Driving Analyzer (PDA)				Pile Order Lengths	
End Bent Bent No.	PDA Testing Required? YES or MAYBE	PDA Test Pile Length FT	Total PDA Testing Quantity EACH	End Bent Bent No.	Pile Order Lengths EST or PCA
END BENT 1 Pile 1.8	MAYBE	50	1		
END BENT 2 Pile 1.8	MAYBE	50	1		
TOTAL QTY					

*ST = Pile order length from estimated pile length & PDA - Pile order lengths based on PDA testing. For groups of end bents with pile order lengths based on PDA testing, the first end bent is to be used for each group as the representative end bent with the PDA.

PILE DESIGN INFORMATION
(Blank entries indicate item is not applicable to structure)

End Bent Bent No. Plan/Profile # E.g., Sheet 1, Plan 1.57	Factored Dead Load per Pile TONS	Factored Overriding Load per Pile TONS	Factored Dead Load per Pile TONS	Dynamic Resistance Factor	Nominal Downing Resistance per Pile TONS	Nominal Score Resistance per Pile TONS	Score Resistance Factor (Default = 1.0)
END BENT 1 Pile 1.8	121.5			0.80			1.00
END BENT 2 Pile 1.8	121.5			0.80			1.00
TOTAL QTY							

*Factored Dead Load is factored weight of pile above the ground line.

SUMMARY OF PILE ACCESSORIES
(Blank entries indicate item is not applicable to structure)

End Bent Bent No. Plan/Profile # E.g., Sheet 1, Plan 1.57	Pile Pipe Required? YES or MAYBE	Pile Pipe Cutting Blade Required? YES	Steel Pipe Points		Steel Pipe Type Required? YES
			H-Pile Cutting Blade Required? YES	H-Pile Points Required? YES	
END BENT 1 Pile 1.8					YES
END BENT 2 Pile 1.8					YES
TOTAL QTY					

SUMMARY OF DRILLED PIER INFORMATION/INSTALLATION
(Blank entries indicate item is not applicable to structure)

End Bent Bent No. Plan/Profile # E.g., Sheet 1, Plan 1.57	Factored Resistance per Pier TONS	Minimum Pier Tip (Top No Higher Than) Elevation FT	Required Tip Resistance per Pier TONS	Score Critical Elevation FT	Minimum Drilled Pier Penetration Into Rock per Pier Lin FT	Drilled Pier Length per Pier Lin FT	Drilled Pier Length to Soil per Pier Lin FT	Drilled Pier Length to Soil per Pier Lin FT	Permanent Steel Casing Required? YES or MAYBE	Permanent Steel Casing Top Elevation (Elev Not to Exceed Casing Base) FT	Permanent Steel Casing Length per Pier Lin FT
BENT 1 Pile 1.3	606	700.0	30		27.0	50.0	57.0				
TOTAL QTY											

*Permanent Steel Casing Length equals the difference between the ground line or top of drilled pier elevation, whichever is higher, and the permanent casing tip elevation.

SUMMARY OF DRILLED PIER TESTING
(Blank entries indicate item is not applicable to structure)

End Bent Bent No. Plan/Profile # E.g., Sheet 1, Plan 1.57	Standard Penetration Test (SPT) Required? YES or MAYBE	Cone/Sonic Logging (CSL) Required? YES or MAYBE	Total CSL Tube Length (EST or PDA) per Pier Lin FT	Steel Casing Length (EST or PDA) per Pier Lin FT	Pile Integrity Test (PIT) Required? MAYBE
BENT 1 Pile 1.3	YES	MAYBE	500	NO	NO
TOTAL QTY					

*CSL Tubes are required if CSL Testing is or may be required. The number of CSL Tubes per drilled pier is equal to one tube per foot of casing per diameter with at least 4 tubes per pier. The length of each CSL Tube is equal to the drilled pier length plus 5.5 ft.

PROJECT NO. _____ COUNTY _____

STATION _____

STATE OF NORTH CAROLINA
DEPARTMENT OF TRANSPORTATION

APPROVED BY: _____ DATE: _____

DESIGNED BY: _____ DATE: _____

SCALE: 1" = _____

REVISIONS: _____

DOCUMENT NOT CONTROLLED
IF FINAL UNLESS ALL
REVISIONS ARE INCORPORATED

SUMMARY OF PILE INFORMATION/INSTALLATION
(Blank entries indicate item is not applicable to structure)

End Bent Bent No. Plan/Profile # E.g., Sheet 1, Plan 1.57	Factored Resistance per Pile TONS	Pile Cap Off (Top of Pile) Elevation FT	Estimated Pile Length per Pile FT	Score Critical Elevation FT	Driven Piles			Preloading for Piles*			Drilled-In Piles			
					Min Pile Tip Elev No Higher Than Elev FT	Required Driving Resistance (RDR) per Pile TONS	Total Pile Resistance per Pile TONS	Preloading Length per Pile Lin FT	Preloading Change (Elev Not to Exceed Below) FT	Maximum Preloading Dia INCHES	Pile Exc N/A In Soil per Pile Lin FT	Pile Exc In Soil per Pile Lin FT	Pile Order Lengths EST or PCA	
END BENT 1 Pile 1.8	50	800.56	50		270	0								
END BENT 2 Pile 1.8	50	803.21	50		270	0								

*Preloading for Piles is required for end bents with a preloading length and at the Contractor's option for end bents with preloading information but no preloading length.
#DR = Factored Resistance / Factored Driving Load / Factored Dead Load / Nominal Driving Resistance / Nominal Score Resistance / Score Resistance Factor

SUMMARY OF PDA/PILE ORDER LENGTHS
(Blank entries indicate item is not applicable to structure)

Pile Driving Analyzer (PDA)				Pile Order Lengths	
End Bent Bent No.	PDA Testing Required? YES or MAYBE	PDA Test Pile Length FT	Total PDA Testing Quantity EACH	End Bent Bent No.	Pile Order Lengths EST or PCA
END BENT 1 Pile 1.8	MAYBE	50	1		
END BENT 2 Pile 1.8	MAYBE	50	1		
TOTAL QTY					

*ST = Pile order length from estimated pile length & PDA - Pile order lengths based on PDA testing. For groups of end bents with pile order lengths based on PDA testing, the first end bent is to be used for each group as the representative end bent with the PDA.

PILE DESIGN INFORMATION
(Blank entries indicate item is not applicable to structure)

End Bent Bent No. Plan/Profile # E.g., Sheet 1, Plan 1.57	Factored Dead Load per Pile TONS	Factored Overriding Load per Pile TONS	Factored Dead Load per Pile TONS	Dynamic Resistance Factor	Nominal Downing Resistance per Pile TONS	Nominal Score Resistance per Pile TONS	Score Resistance Factor (Default = 1.0)
END BENT 1 Pile 1.8	121.5			0.80			1.00
END BENT 2 Pile 1.8	121.5			0.80			1.00
TOTAL QTY							

*Factored Dead Load is factored weight of pile above the ground line.

SUMMARY OF PILE ACCESSORIES
(Blank entries indicate item is not applicable to structure)

End Bent Bent No. Plan/Profile # E.g., Sheet 1, Plan 1.57	Pile Pipe Required? YES or MAYBE	Pile Pipe Cutting Blade Required? YES	Steel Pipe Points		Steel Pipe Type Required? YES
			H-Pile Cutting Blade Required? YES	H-Pile Points Required? YES	
END BENT 1 Pile 1.8					YES
END BENT 2 Pile 1.8					YES
TOTAL QTY					

SUMMARY OF DRILLED PIER INFORMATION/INSTALLATION
(Blank entries indicate item is not applicable to structure)

End Bent Bent No. Plan/Profile # E.g., Sheet 1, Plan 1.57	Factored Resistance per Pier TONS	Minimum Pier Tip (Top No Higher Than) Elevation FT	Required Tip Resistance per Pier TONS	Score Critical Elevation FT	Minimum Drilled Pier Penetration Into Rock per Pier Lin FT	Drilled Pier Length per Pier Lin FT	Drilled Pier Length to Soil per Pier Lin FT	Drilled Pier Length to Soil per Pier Lin FT	Permanent Steel Casing Required? YES or MAYBE	Permanent Steel Casing Top Elevation (Elev Not to Exceed Casing Base) FT	Permanent Steel Casing Length per Pier Lin FT
BENT 1 Pile 1.3	606	700.0	30		27.0	50.0	57.0				
TOTAL QTY											

*Permanent Steel Casing Length equals the difference between the ground line or top of drilled pier elevation, whichever is higher, and the permanent casing tip elevation.

SUMMARY OF DRILLED PIER TESTING
(Blank entries indicate item is not applicable to structure)

End Bent Bent No. Plan/Profile # E.g., Sheet 1, Plan 1.57	Standard Penetration Test (SPT) Required? YES or MAYBE	Cone/Sonic Logging (CSL) Required? YES or MAYBE	Total CSL Tube Length (EST or PDA) per Pier Lin FT	Steel Casing Length (EST or PDA) per Pier Lin FT	Pile Integrity Test (PIT) Required? MAYBE
BENT 1 Pile 1.3	YES	MAYBE	500	NO	NO
TOTAL QTY					

*CSL Tubes are required if CSL Testing is or may be required. The number of CSL Tubes per drilled pier is equal to one tube per foot of casing per diameter with at least 4 tubes per pier. The length of each CSL Tube is equal to the drilled pier length plus 5.5 ft.

Link to: \\Dor\dfsroot\01\Groups\SDCC\DEVA\Individual Folders\Samuel\OBD\Geotech Tables\NCDOT BRR N/C70 Over US220 Geotechnical Foundation Tables 08-05-22.stbrm\Piles 08-05-22.rvt
Drilled Pier\CR767C31
Level: Default

NOTES:
1. The Pile and Drilled Pier Foundation Tables are based on the bridge substructure design and foundation recommendations sealed by a North Carolina Professional Engineer (Robert Lawrence, PE 054068) on 08-15-2022.
2. Total Pile Driving Equipment Setup quantity (not shown in Pile Foundation Tables) equals the number of driven piles, i.e., the number of piles with a Required Driving Resistance.
3. The Engineer will determine the need for PDA Testing, Permanent Steel Casing, SPTs, CSL Testing, SPT Inspections and PITs when these items may be required.

PROJECT NO. _____ COUNTY _____

STATION _____

STATE OF NORTH CAROLINA
DEPARTMENT OF TRANSPORTATION

APPROVED BY: _____ DATE: _____

DESIGNED BY: _____ DATE: _____

SCALE: 1" = _____

REVISIONS: _____

DOCUMENT NOT CONTROLLED
IF FINAL UNLESS ALL
REVISIONS ARE INCORPORATED

Any part of the spreadsheet can be linked as a separate link on this plan sheet. Remember to add the needed Foundation Notes from the SMU Notes tab in OBD.

5.3.9 Edit Link Properties

You may resize the tables either by adjusting the handles/borders or by changing the scale in properties as shown below:

SUMMARY OF PILE INFORMATION/INSTALLATION
(Blank entries indicate items not applicable to structure)

End Bent Bent No. Pile # Pile L	Factored Resistance per Pile TONS	Pile Cap Diameter ft	Estimated PDA Load per Pile FT	Score Factor	Drilled Piles		Piling by Pile		Drilled-in Piles	
					Min Pile Tip Dia No Higher Than Cap FT	Required Driving Resistance per Pile TONS	Total Pile Resistance Quantity EACH	Prohibiting Driving Else Not To Prohibit FT	Maximum Prohibiting Dist INCHES	Excessive Disturbance Per Pile FT
END BENT 1 Piles 1-4	52	30.0	52	1.00	30.0	0	0	0	0	0
END BENT 2 Piles 1-4	52	30.0	52	1.00	30.0	0	0	0	0	0

SUMMARY OF PDA/PILE ORDER LENGTHS
(Blank entries indicate items not applicable to structure)

End Bent Bent No.	PDA Testing Required? YES or MAYBE	PDA Test Length FT	Total PDA Testing Quantity EACH	Pile Order Lengths	
				End Bent Bent No.	Pile Order Length EACH
END BENT 1 Piles 1-4	YES	30	1		
END BENT 2 Piles 1-4	YES	30	1		

SUMMARY OF PILE DESIGN INFORMATION
(Blank entries indicate items not applicable to structure)

End Bent Bent No. Pile # Pile L	Factored Axial Load per Pile TONS	Factored Downward Load per Pile TONS	Nominal Downward Resistance Factor	Dynamic Resistance Factor	Nominal Downward Resistance per Pile TONS	Nominal Score Resistance per Pile TONS	Score Resistance Factor (Default = 1.0)
END BENT 2 Piles 1-4	52	0.0	1.00	1.00	1.00	1.00	1.00

SUMMARY OF DRILLED PIER INFORMATION/INSTALLATION
(Blank entries indicate items not applicable to structure)

End Bent Bent No. Pile # Pile L	Factored Resistance per Pile TONS	Minimum Pile Tip Height FT	Required Tip Resistance per Pile FT	Score Factor	Minimum Drilled Pier Resistance per Pile LIN FT	Drilled Pier Length per Pile LIN FT	Drilled Pier Length Not In Soil per Pile LIN FT	Permanent Steel Casing Length per Pile LIN FT	Permanent Steel Casing Test Location (Use Not To Exceed Casing Depth) FT	Permanent Steel Casing Length per Pile LIN FT
END BENT 2 Piles 1-4	52	30.0	52	1.00	30.0	30.0	0.0	0.0	0.0	0.0

SUMMARY OF DRILLED PIER TESTING
(Blank entries indicate items not applicable to structure)

End Bent Bent No. Pile # Pile L	Factored Resistance per Pile TONS	Concrete Test (SPT) Required? YES or MAYBE	C/S Table Logging Required? YES or MAYBE	C/S Table Logging of or At Table Required? YES or MAYBE	Inspection Check (DCI) Required? YES or MAYBE	PDA Testing Required? YES or MAYBE
END BENT 2 Piles 1-4	52	YES	NO	NO	NO	NO

NOTES:
1. The Pile and Drilled Pier Foundation Tables are based on the bridge substructure design and foundation recommendations sealed by a North Carolina Professional Engineer (Robert Lawrence, PE 05-4006) on 08-15-2022.
2. Total Pile Driving Equipment Setup quantity (not shown in Pile Foundation Tables) equals the number of driven piles, i.e., the number of piles with a Required Driving Resistance.
3. The Engineer will determine the need for PDA Testing, Permanent Steel Casing, SPTs, C/S, Table Logging, DCI Inspections and PRTs when these items may be required.

Use these handles to adjust the size.

Hover over the table border to access the properties menu.

Update the scale to 1:1 or as deemed fit.

Element Desc: Link to: \Dtd\tdfstr
Level: Default
Color: 0
Line Style: 0
Weight: 0
Class: Primary
Template: (None)
Transparency: 0
Priority: 0
Transparent: Yes
View Rotation: View Dependent

Aspect Ratio: No
Scale X: 1.00000
Scale Y: 1.00000
Size X: 2' 6.47198633"
Size Y: 1' 2.92359220"

Model: Fdn Tables Sheet
Last Modified: 5/16/2023 12:22:40
Snappable: Not Snappable
Modified: Modified
New: New
Locked: Unlocked
Display Style: (From View Display)

Element ID: 3770
> Range Low: 0' 1.68600000", 0' 0"
Range High: 2' 8.15880000", 1' 9"
Size: 156
Linkages: 2
XAttributes: 0

If you forget to select Transparent Background, you may change that from properties by choosing YES for Transparent.

CONTENTS

Chapter 7.....7-1

7.1 Title Sheet.....7-1

7.1.1 Roadway Title Sheet7-1

7.1.2 No Roadway Title Sheet.....7-5

7.2 Index Sheet.....7-7

7.3 Superstructure Sheets7-10

7.3.1 2D Drawings.....7-10

7.3.2 3D Models to 2D Plans7-14

Typical Section.....7-14

7.4 Substructure Sheets.....7-18

7.4.1 2D Drawings.....7-18

7.4.2 3D Models to 2D Plans7-21

7.5 SMU Standard Drawings & Plans.....7-24

7.5.1.1 SMU Standards in the Default Model7-24

7.5.1.2 SMU Standards in the Sheet Model7-26

DRAFT

CHAPTER 7 PLAN SHEET CREATION

7.1 TITLE SHEET

A title sheet is used to provide project information including the project number, location, type of work, vicinity map, project map, project length, and roadway/traffic design data. A title sheet can be created one of two ways, either by referencing the Roadway title sheet or creating a new title sheet using the SMU title sheet cell. For required title sheet content, refer to Chapter 1 of the *NCDOT Structures Management Design Manual*.

7.1.1 Roadway Title Sheet

Create a title sheet DGN following the file naming convention in Chapter 2. Once the DGN has been created, go to the **Home tab > Primary ribbon > Attach Tools > References**

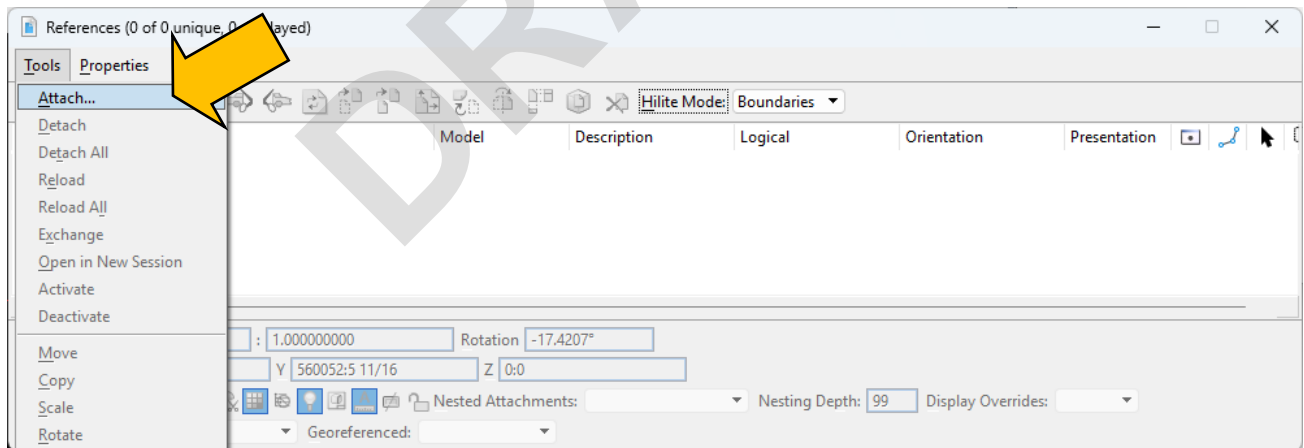
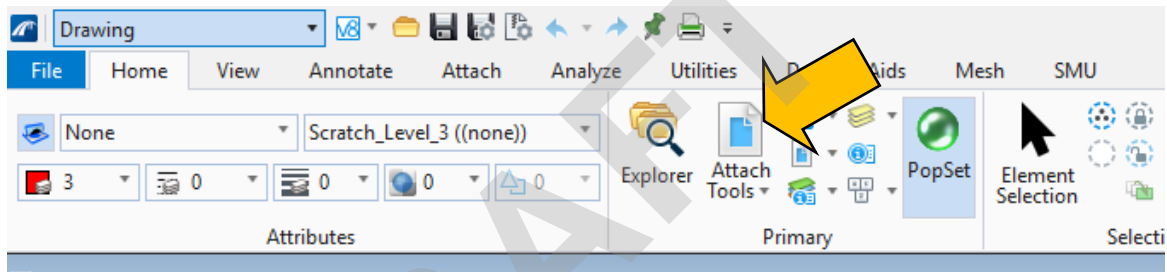

Find and attach the Roadway title sheet into the default model.

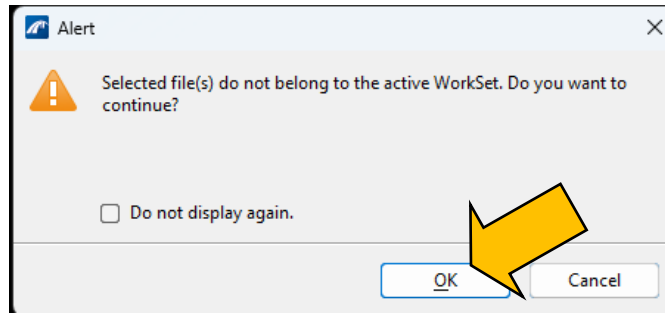

The WorkSet for the referenced file is not SMU's, so click "OK" to continue.

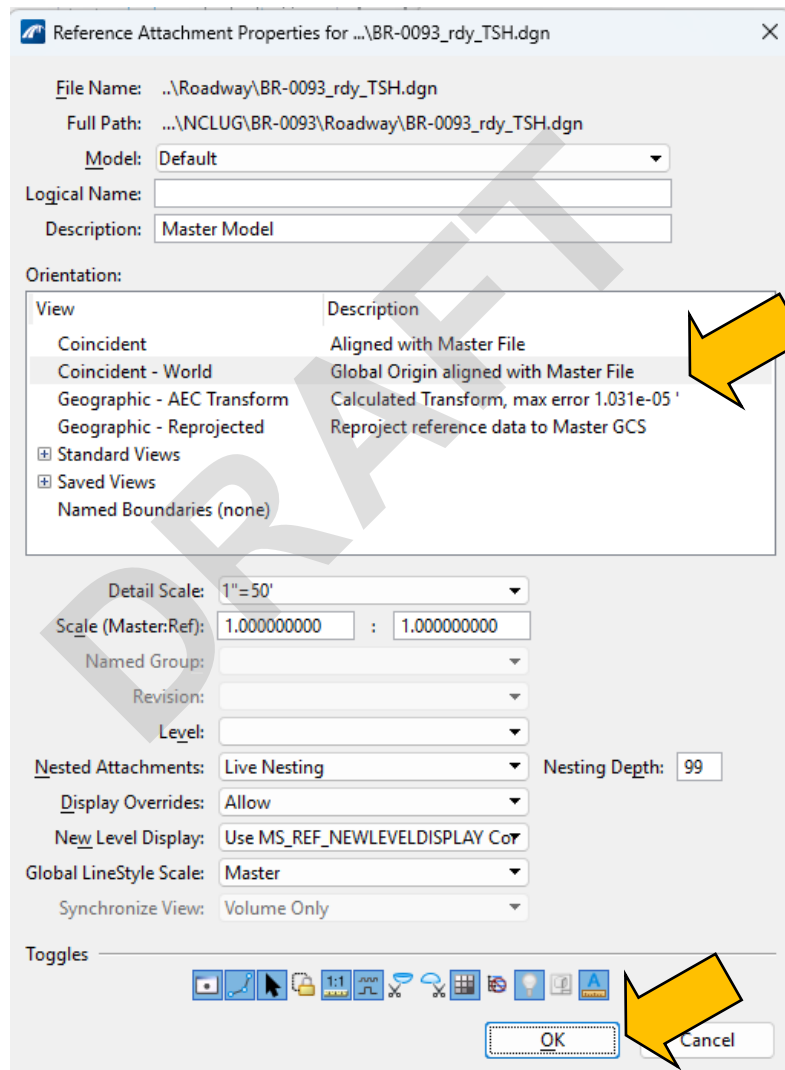

Set the orientation to "Coincident-World" and click "OK"

Fit the view.



Use the Place Named Boundary tool to create the drawing and sheet models.

View tab > Named Boundaries ribbon > Place Named Boundary Tool > By 2 Points

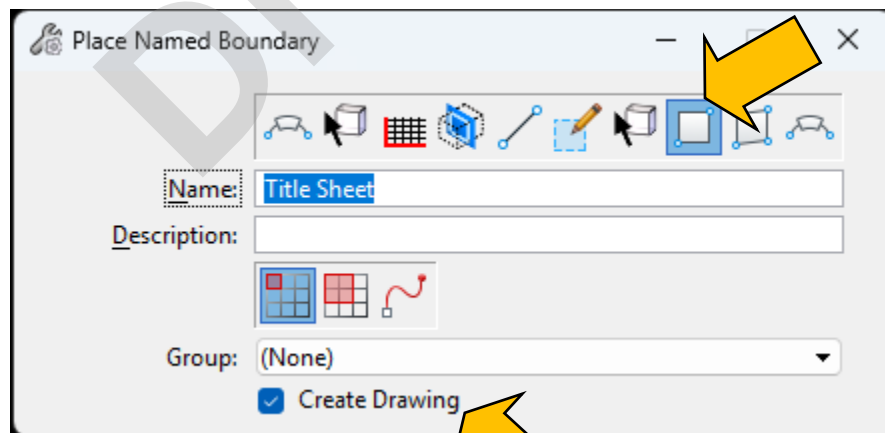
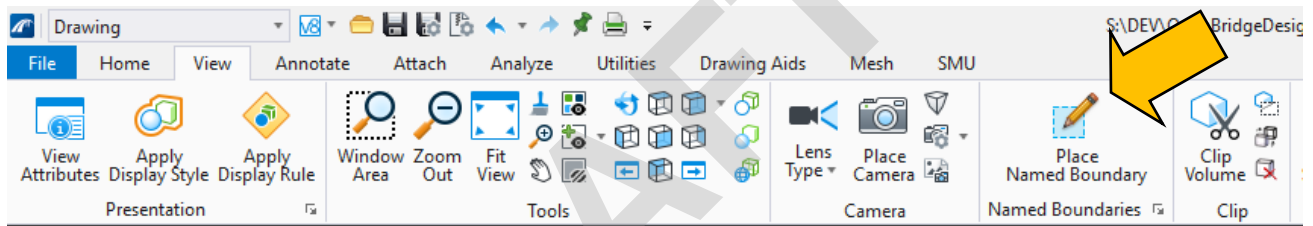

Using an SMU Scratch Level, place a boundary by two points around the plan sheet.

Create a Sheet Model.

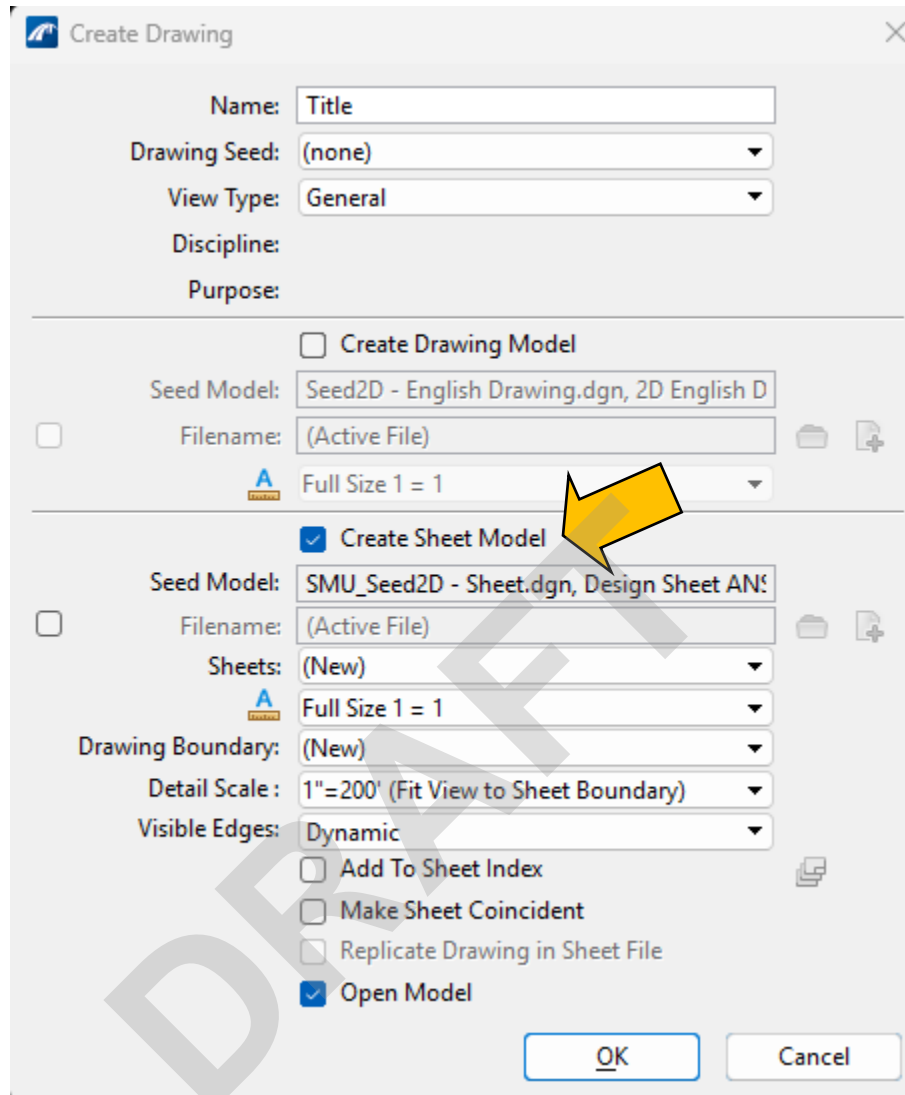

In the sheet model, text and other non-relevant content can either be masked or levels turned off, new text can be placed in the drawing model as needed.

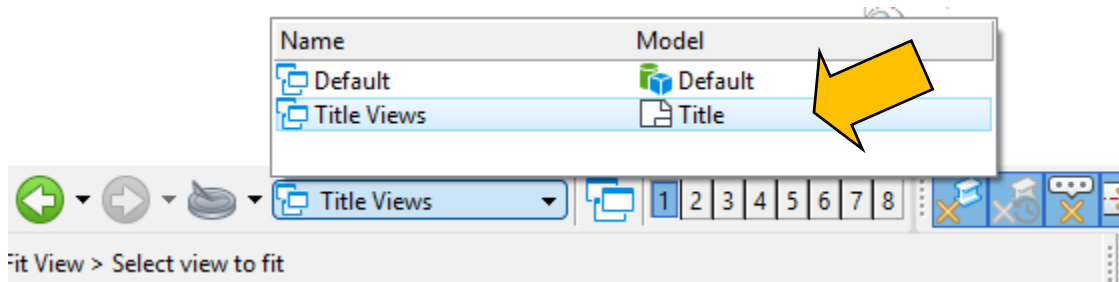

Right click > Turn Level Off by Element

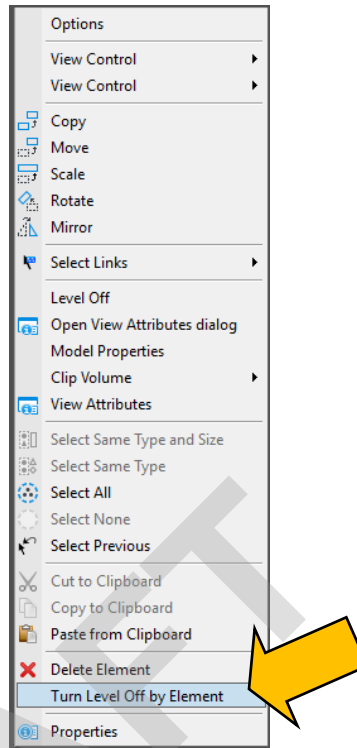

Using the tool, then select elements to be turned off and replaced with what is needed for the structures portion of the project.

Note copying the Roadway title sheet can lead to making the file read only.

7.1.2 No Roadway Title Sheet

Some projects, such as a bridge preservation project or an in-kind timber bridge replacement project, don't always have a roadway title sheet and need one created.

Create a title sheet DGN following the file naming convention in Chapter 2. Once the DGN has been created, use the steps found in Section 3.7.1.3 to create a sheet model.

The SMU Title Sheet is available as a cell. In the sheet model, go to the **Annotate tab > Cells ribbon > Place Active Cell tool > Active Cell**

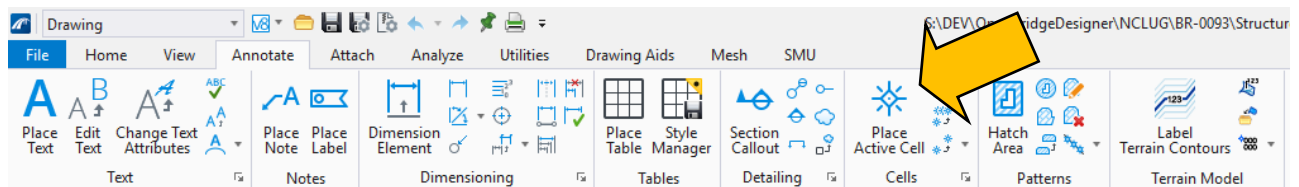

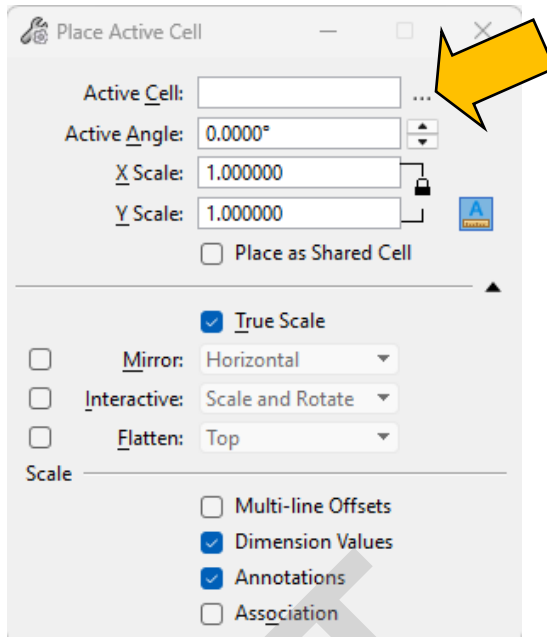

File > SMU_Annotation cell library.

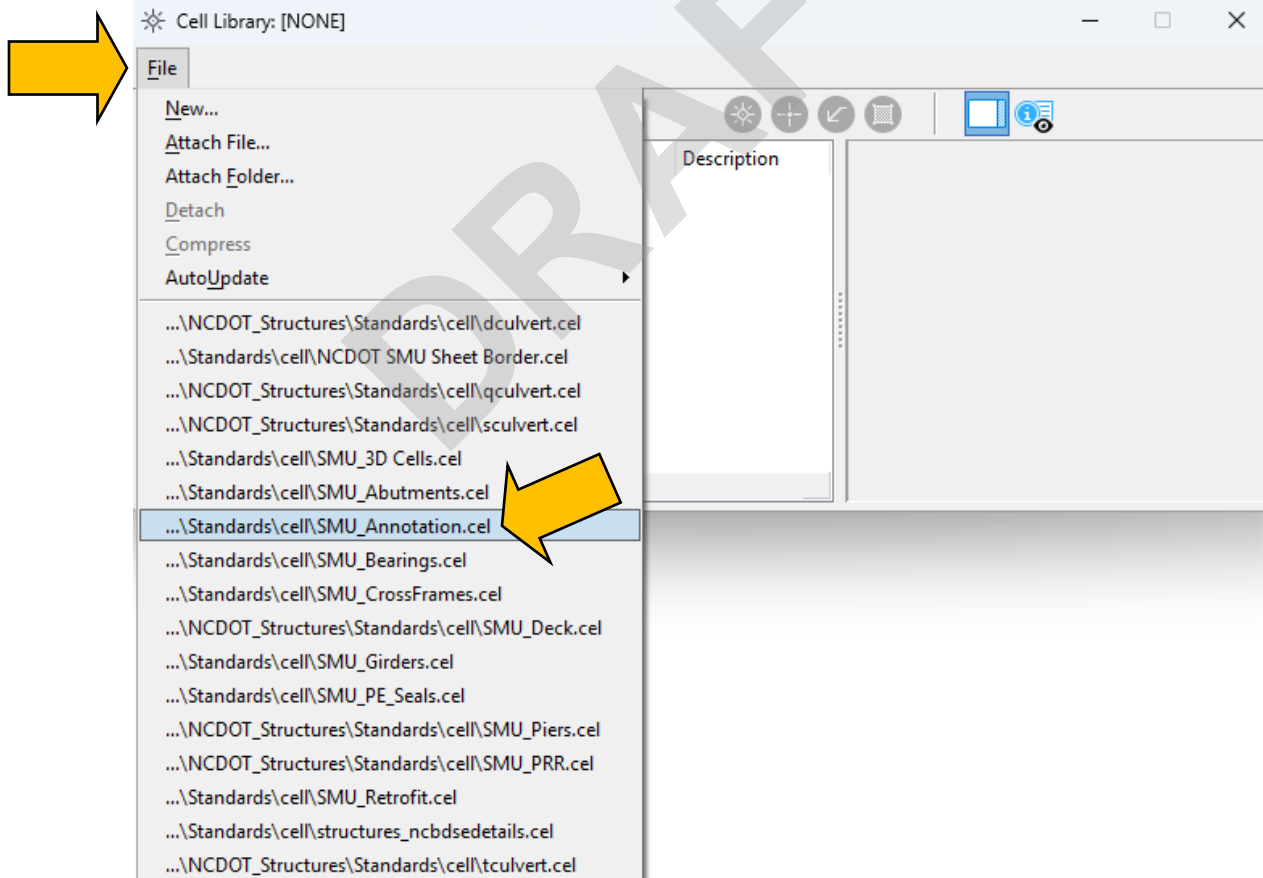

Find the “Title Sheet” cell and place it within the ANCI-D sheet print border.

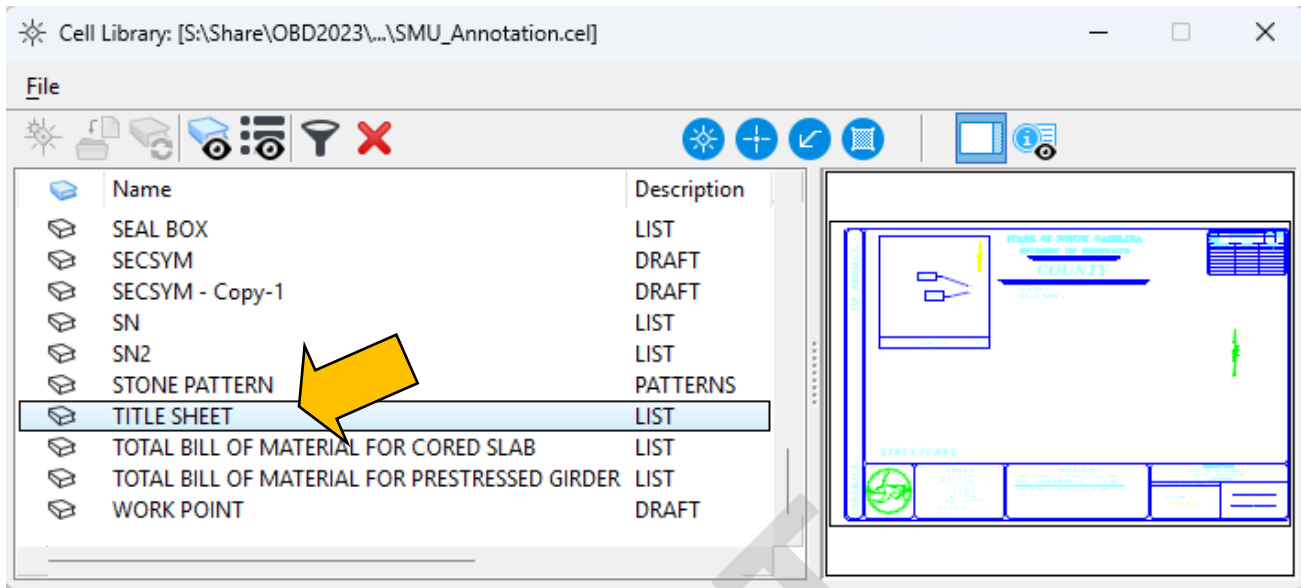

Edit the placed title sheet as needed, note it might need to be dropped to edit.

7.2 INDEX SHEET

Create an index sheet DGN following the file naming convention in Chapter 2. Once the DGN has been created, use the steps found in Section 3.7.1.3 to create a sheet model.

The SMU Index Sheet is available as a cell. In the sheet model, go to the **Annotate tab > Cells ribbon > Place Active Cell tool > Active Cell**

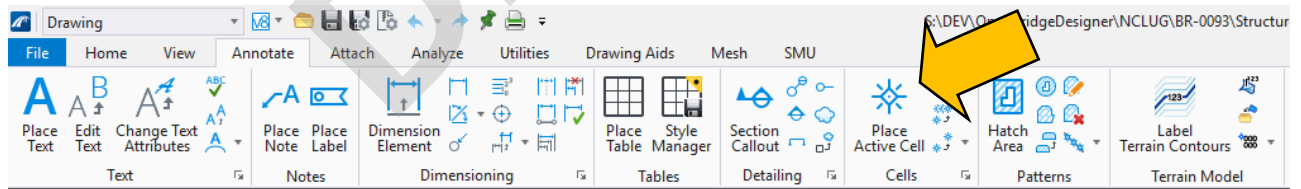

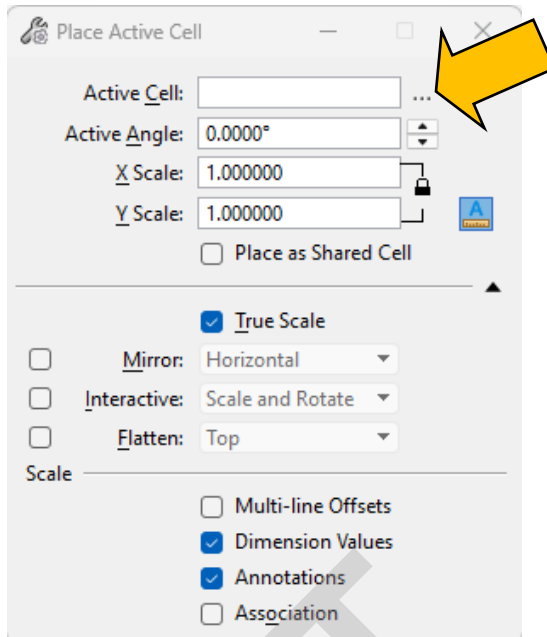

File > SMU_Annotation cell library.

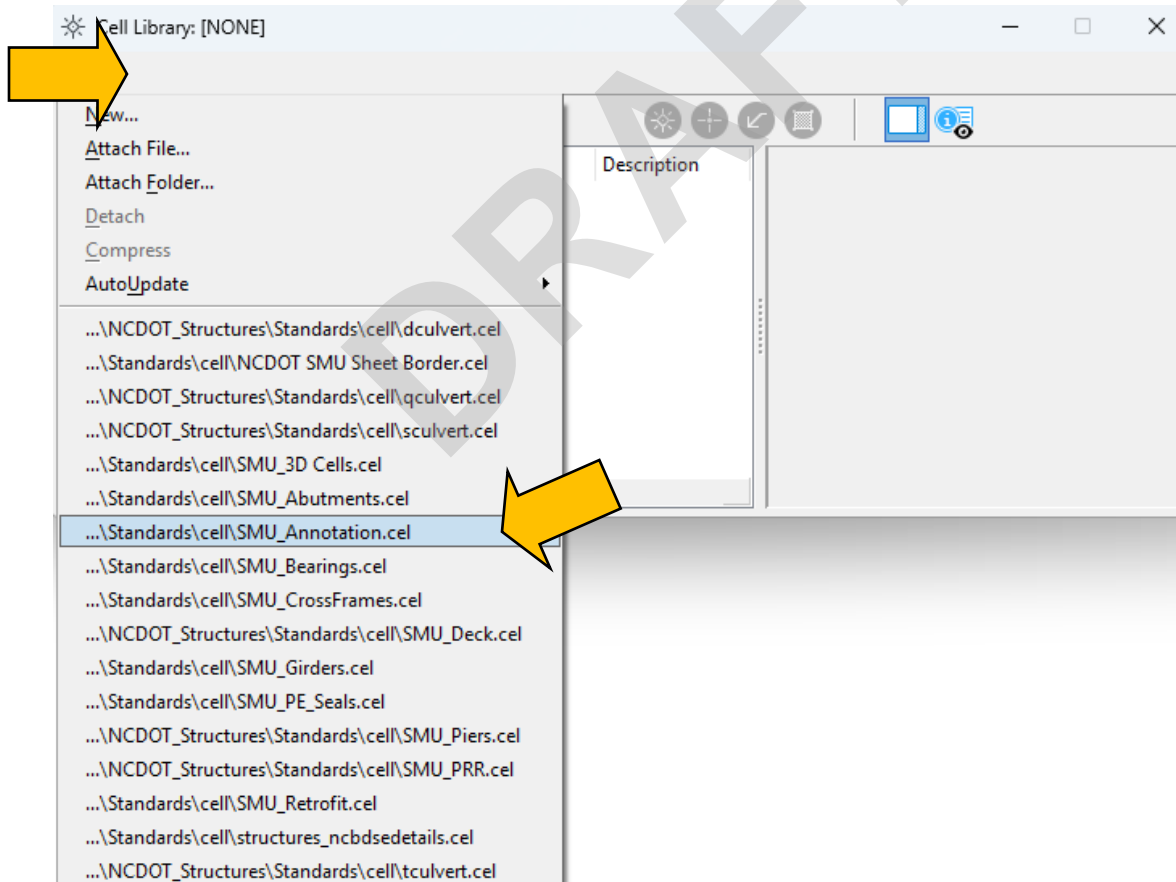

Find the “Index Sheet” cell and place it within the ANCI-D sheet print border.

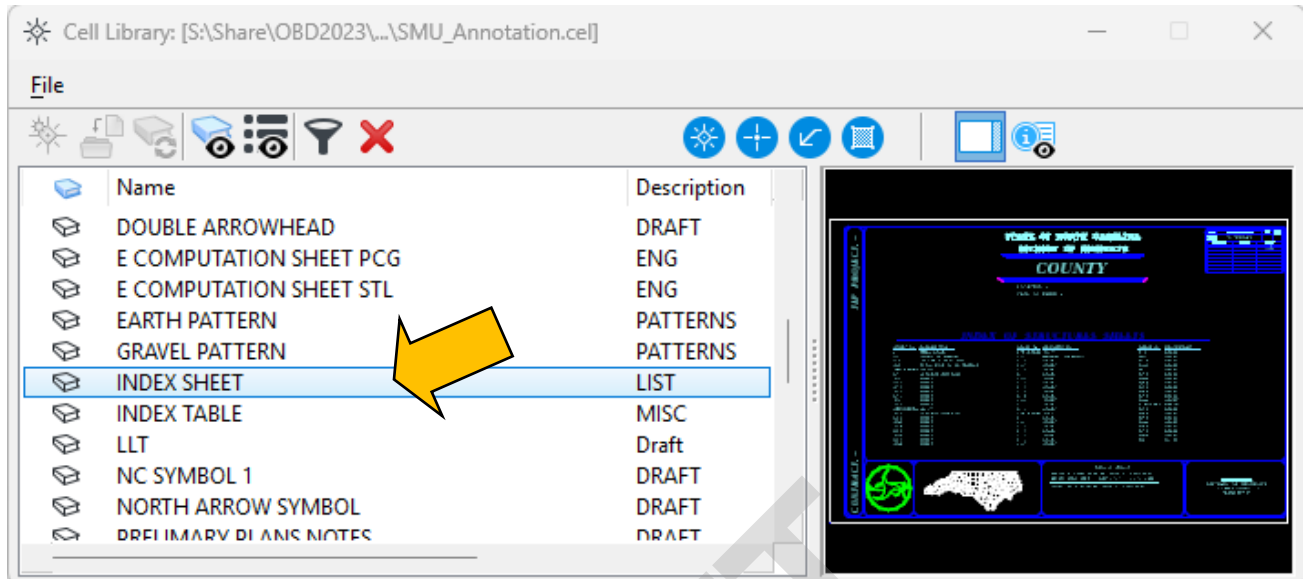

Edit the placed index sheet as needed, note it might need to be dropped to edit.

DRAFT

7.3 SUPERSTRUCTURE SHEETS

Superstructure sheets include the typical section throughout the superstructure, plan of spans, bridge framing plan, girder/beam details, diaphragm details, expansion joint details, barrier rails details, and bearing detail sheets. For detailed guidance on what is required in those plan sheets, see Chapter 6 of the SMU Design Manual.

Use SMU’s Standard Plans as appropriate, following the steps in Section 6.5.

7.3.1 2D Drawings

Create a DGN for each superstructure plan sheet to be drawn following the file naming convention in Chapter 2. Once the DGN has been created, draw the superstructure elements full scale 1:1 in the Design (default) Model, and dimensioned in the Drawing Model, with final plan sheet assembly in the Sheet Model.

Superstructure sheets will commonly use the “Design Plan Profile” or “PRR Plan Profile” SMU borders in the Sheet Model.

Use the SMU Element Templates to match the corresponding line styles, weights, levels, features, and material properties to the elements being drawn.

Once the elements are drawn in the Design Model, use the place named bound tool as follows to create the Drawing and Sheet Models.

View > Named Boundaries > Place Named Boundary

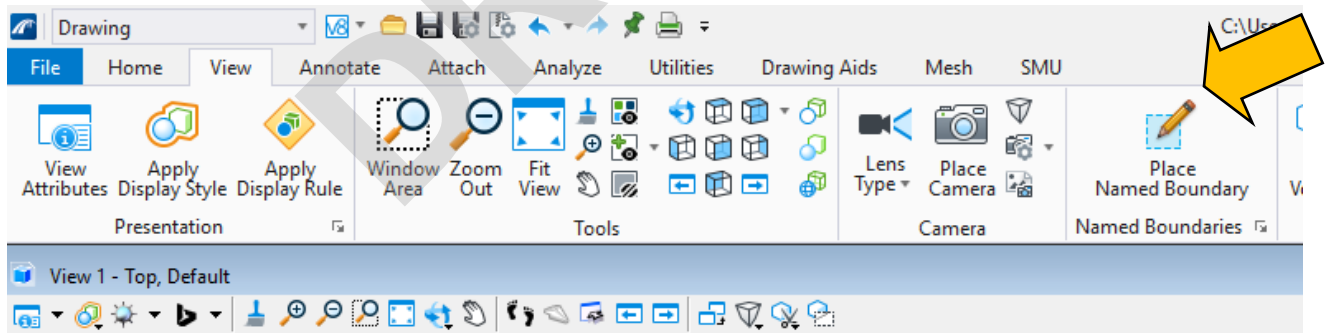

Use the By 2 Points tool

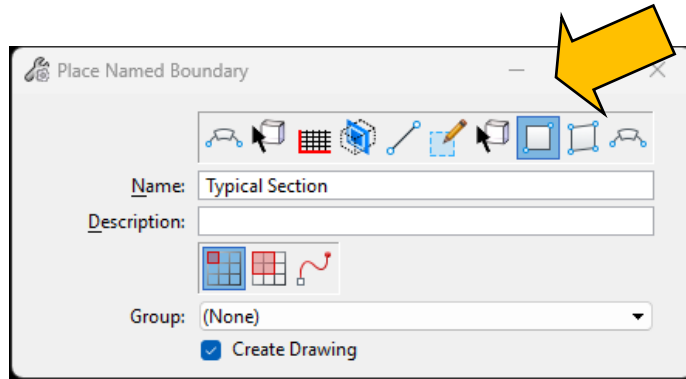

Place the fence around the superstructure element to be placed on the plan sheet.

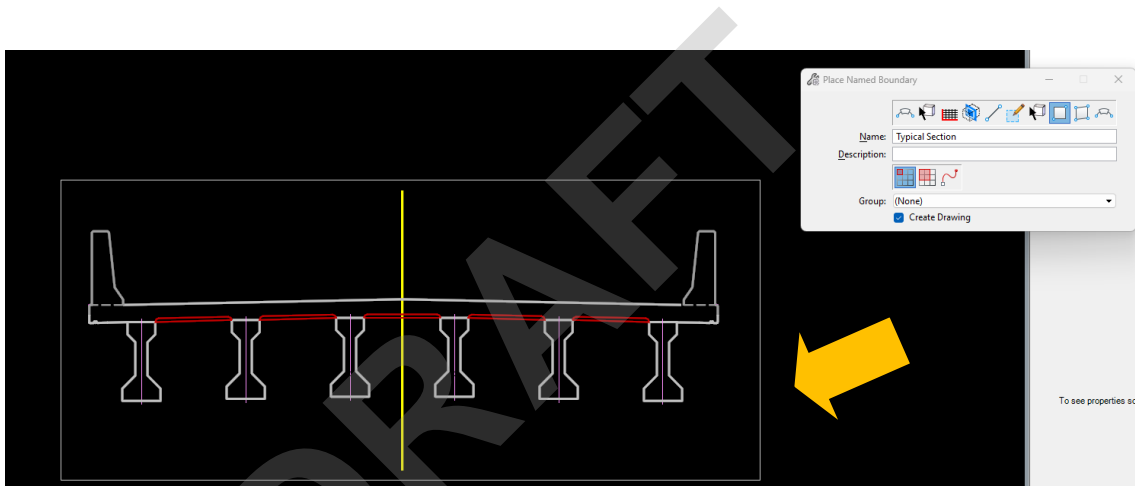

Create the Drawing Model and Sheet Model

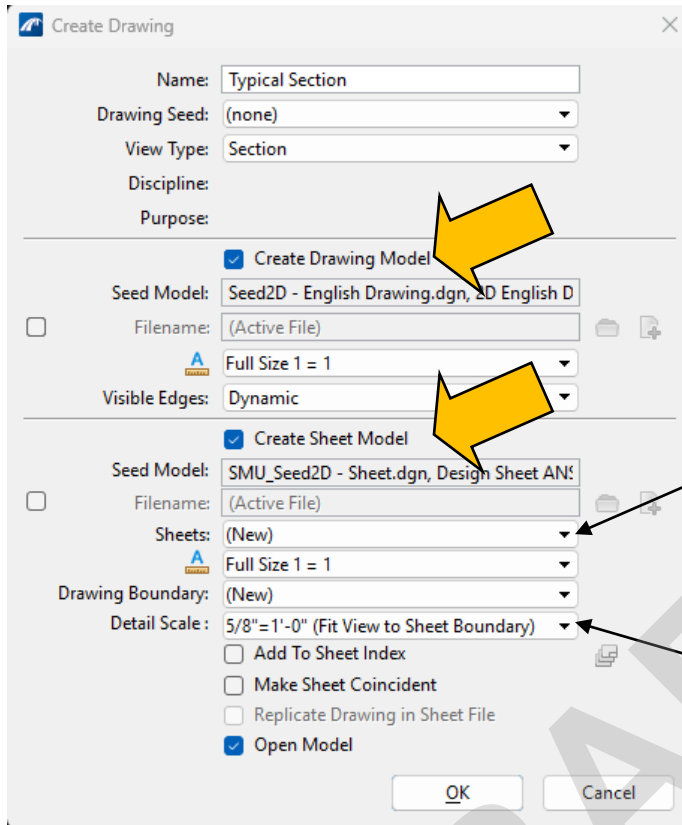

Note: If a Sheet Model has already been created for the DGN, use the drop down to select the sheet model you want the drawing to appear on.

The detail scale is auto generated trying to fit the fenced area into the pre-determined box on the SMU plan sheet. This can be adjusted later if need be.

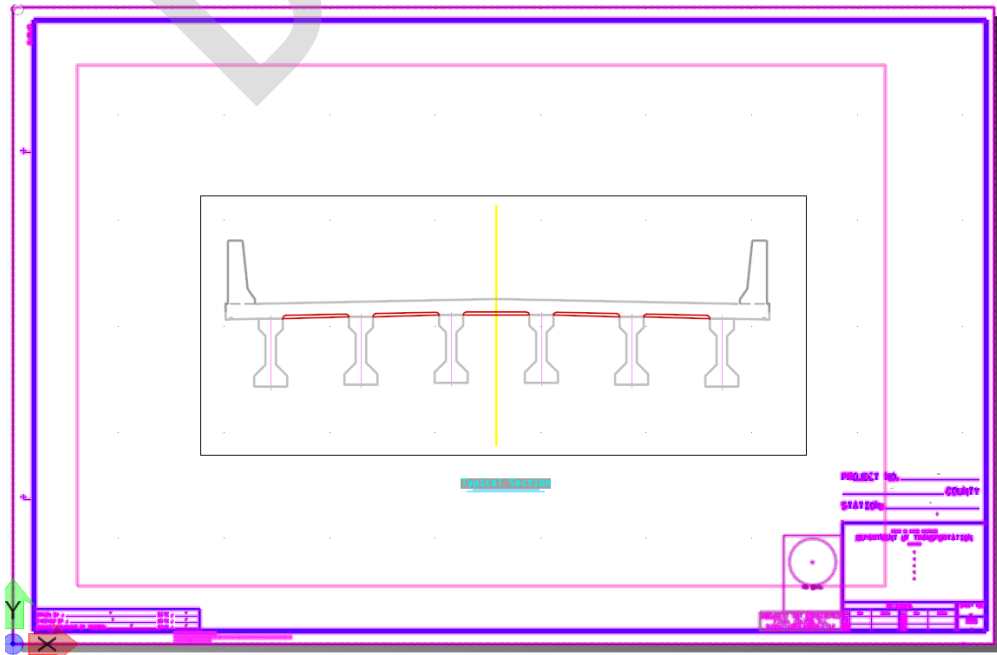

The placed named boundary item can be moved and scaled up or down on the plan sheet using the References tool.

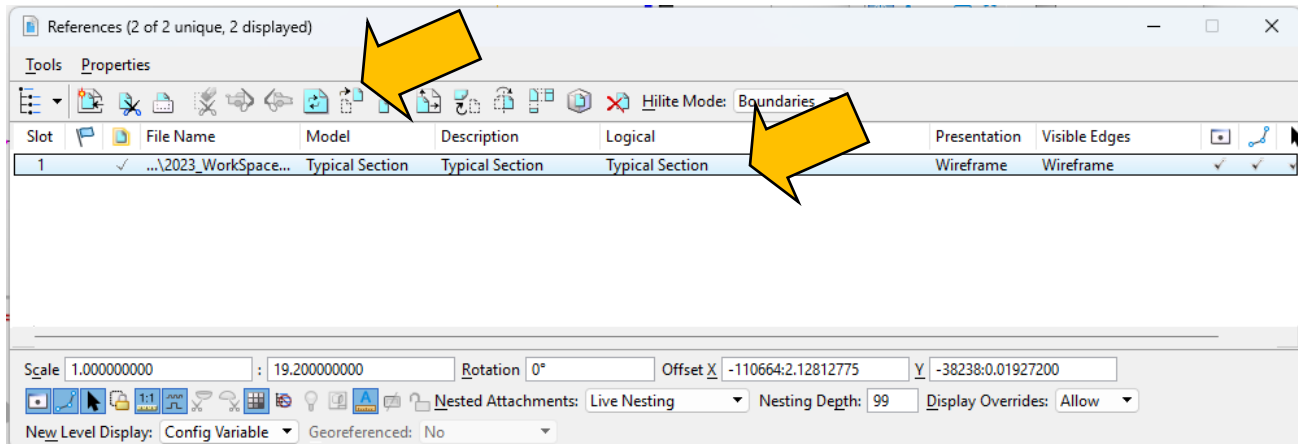

Once the element is at the scale that works for the plan sheet, the element can be annotated in the Drawing Model. Note, set the drawing scale in the Drawing Model to the scale used for the placed named boundary in the Sheet Model.

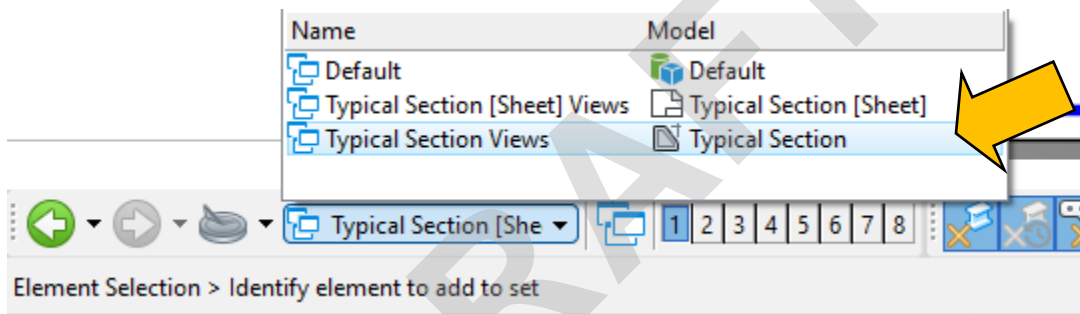

In the Drawing Model, detail reinforcing steel and annotate the drawing.

In the Sheet Model, place notes using the SMU NOTES app and detail cells.

7.3.2 3D Models to 2D Plans

Use the 3D model DGN created following the steps laid out in Chapter 7 to create a 3D structure model. Once the 3D structure model has been created, a DGN will need to be created for each required 2D superstructure plan sheet.

Typical Section

To create a 2D typical section view from the 3D model, use the Typical Section tool.

Reports and Drawings > Drawings > Typical Section

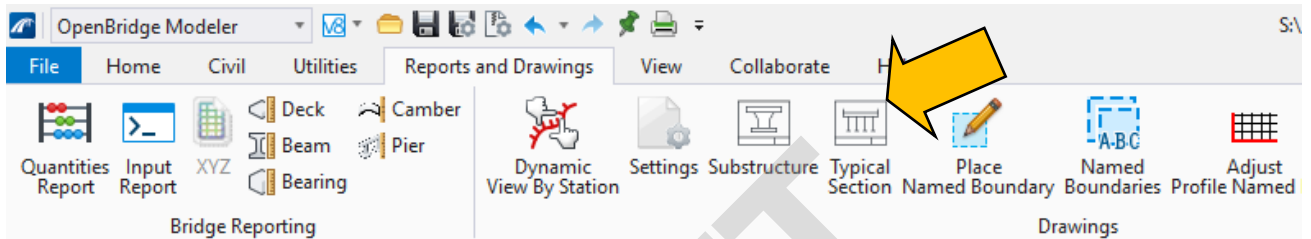

Select the alignment

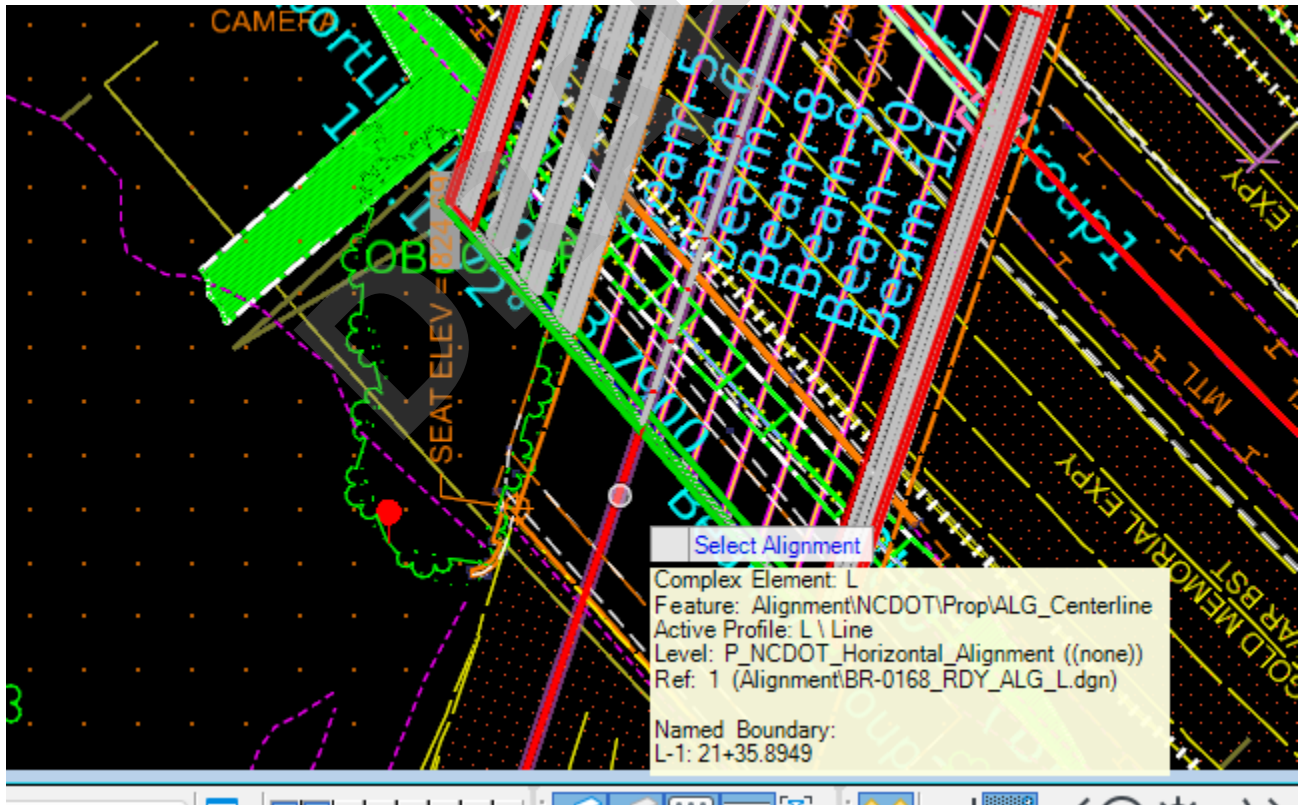

Locate a section on the bridge for a good typical section slice

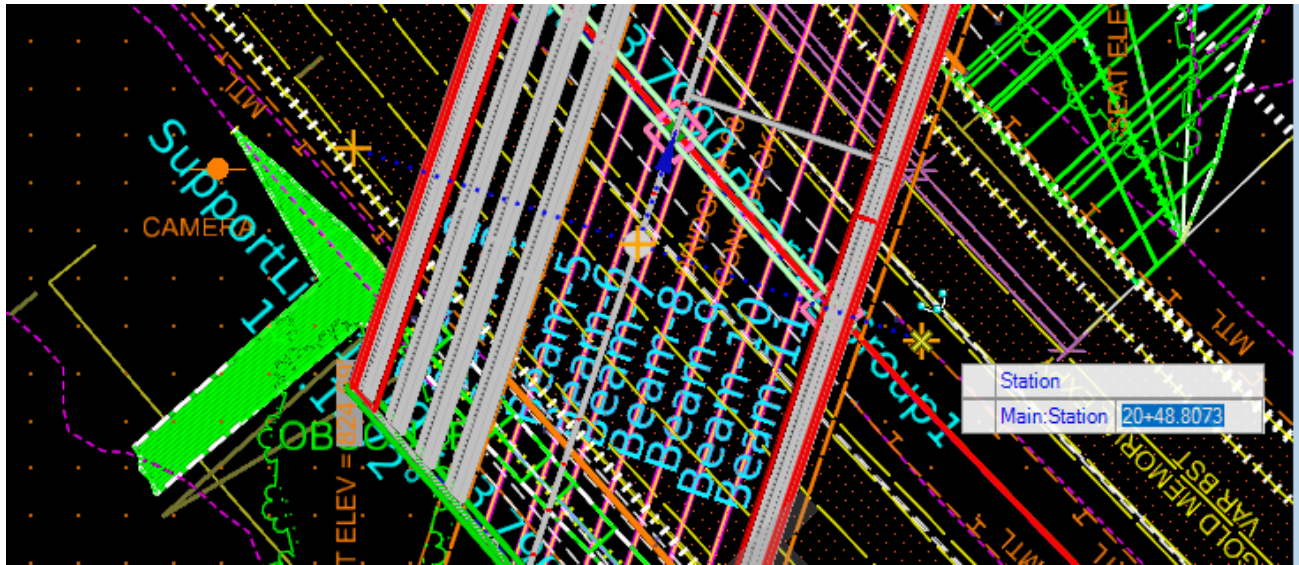

Create the Drawing Model and Sheet Model

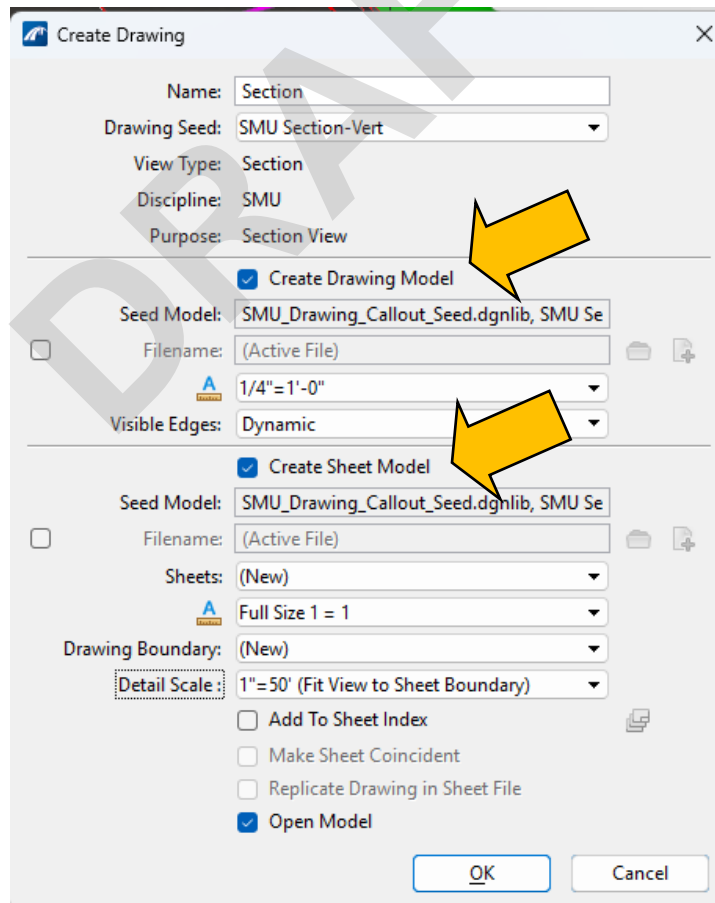

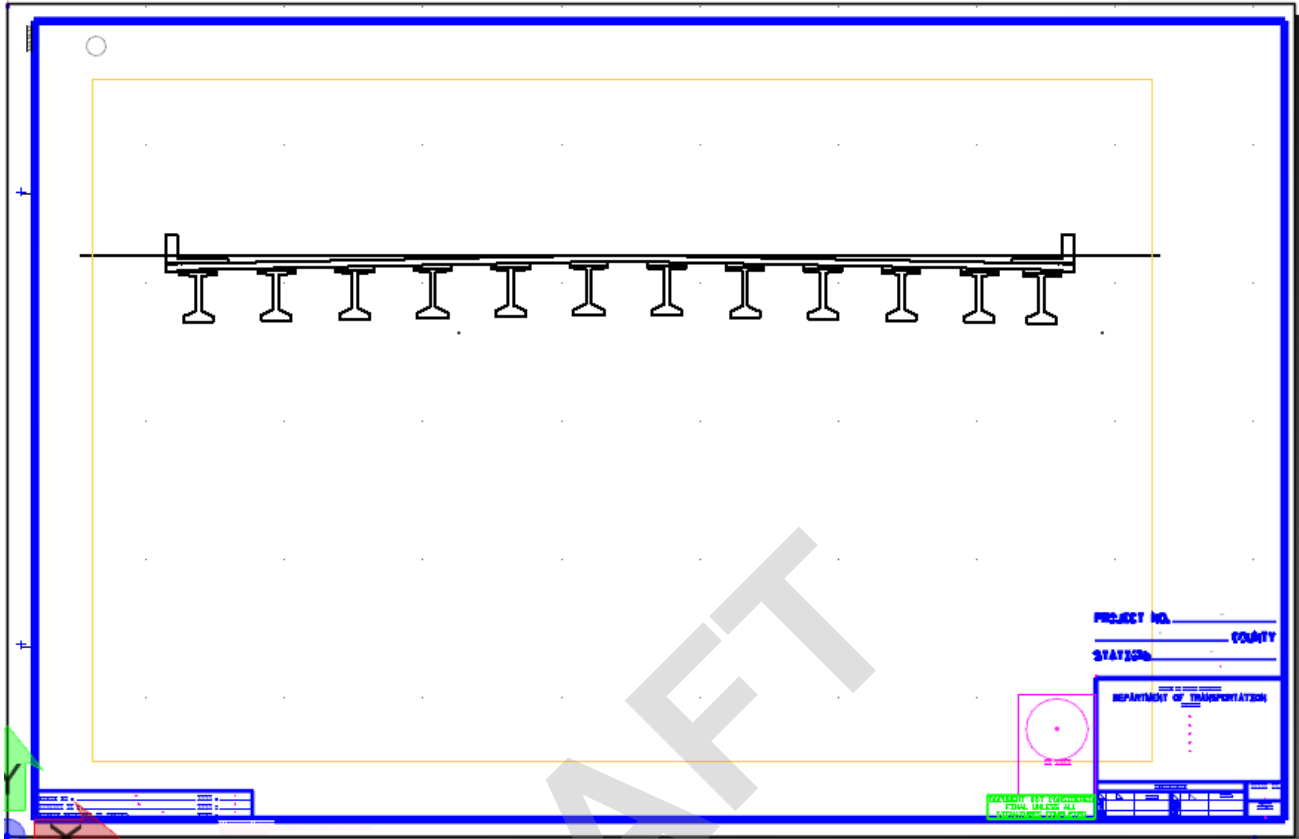

The typical section can be moved and scaled up or down on the plan sheet using the References tool.

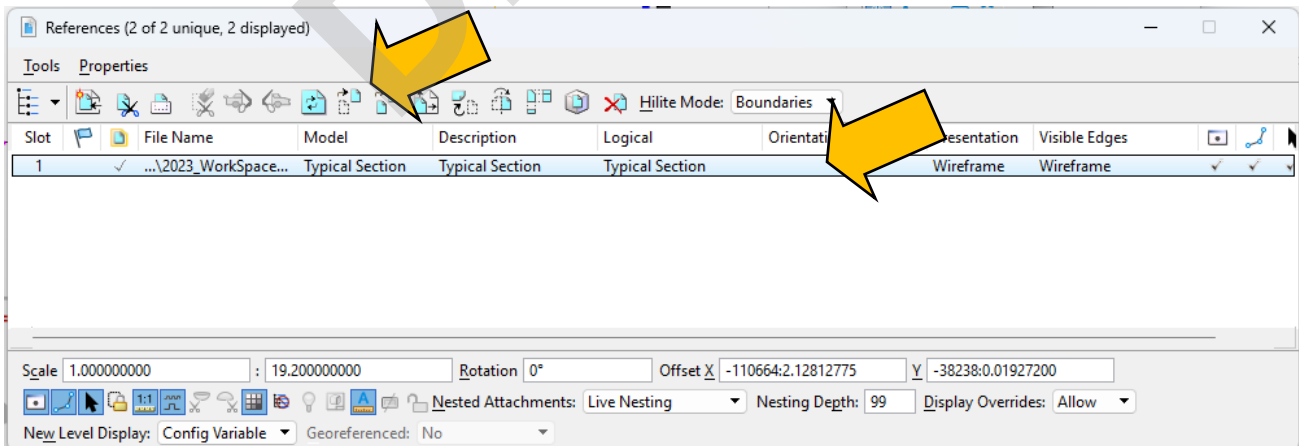

Once the element is at the scale that works for the plan sheet, the element can be annotated in the Drawing Model. Note, set the drawing scale in the Drawing Model to the scale used for the placed named boundary in the Sheet Model.

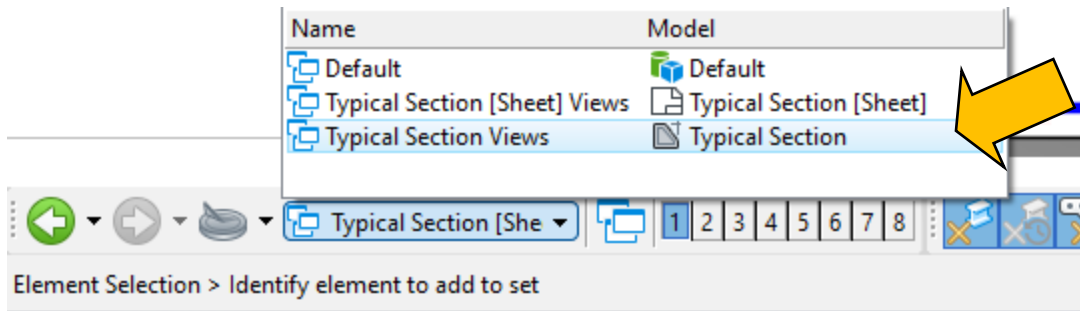

In the Drawing Model, detail reinforcing steel and annotate the drawing.

In the Sheet Model, place notes using the SMU NOTES app and detail cells.

DRAFT

7.4 SUBSTRUCTURE SHEETS

Substructure sheets detail end bent caps, bent caps, columns, piles, drilled piers, footings, pile caps, and wing walls. For detailed guidance on what is required in substructure plan sheets, see chapter 7 of the SMU Design Manual.

Use SMU’s Standard Plans as appropriate, following the steps in Section 6.5.

7.4.1 2D Drawings

Substructure elements should be drawn full scale 1:1 in the Design Model, and dimensioned in the Drawing Model, with final plan sheet assembly in the Sheet Model. Substructure sheets will commonly use the “Design Plan Profile” or “PRR Plan Profile” SMU borders in the Sheet Model. Use the SMU Element Templates to match the corresponding line styles, weights, levels, features, and material properties to the elements being drawn. Use SMU’s Standard Plans as appropriate, following the steps in Section 5.12.

Substructure sheets will commonly use the “Design Plan Profile” or “PRR Plan Profile” SMU borders in the Sheet Model.

Use the SMU Element Templates to match the corresponding line styles, weights, levels, features, and material properties to the elements being drawn.

Once the elements are drawn in the Design Model, use the place named bound tool as follows to create the Drawing and Sheet Models.

View > Named Boundaries > Place Named Boundary

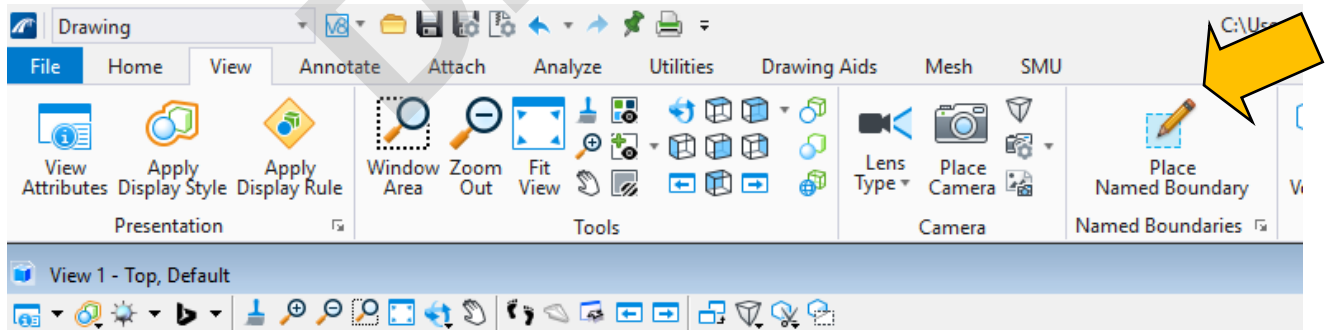

Use the By 2 Points tool

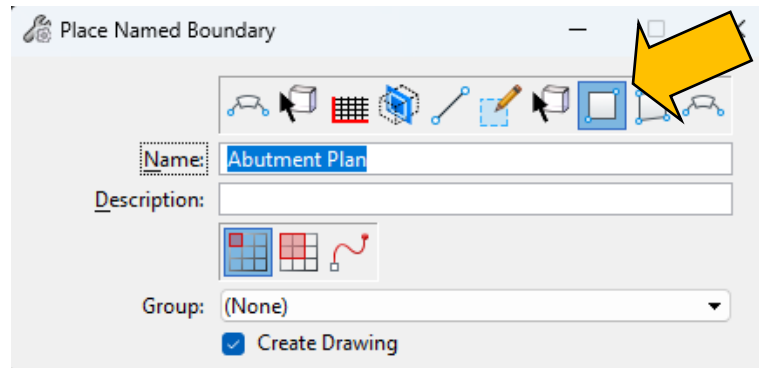

Place the fence around the substructure element to be placed on the plan sheet.

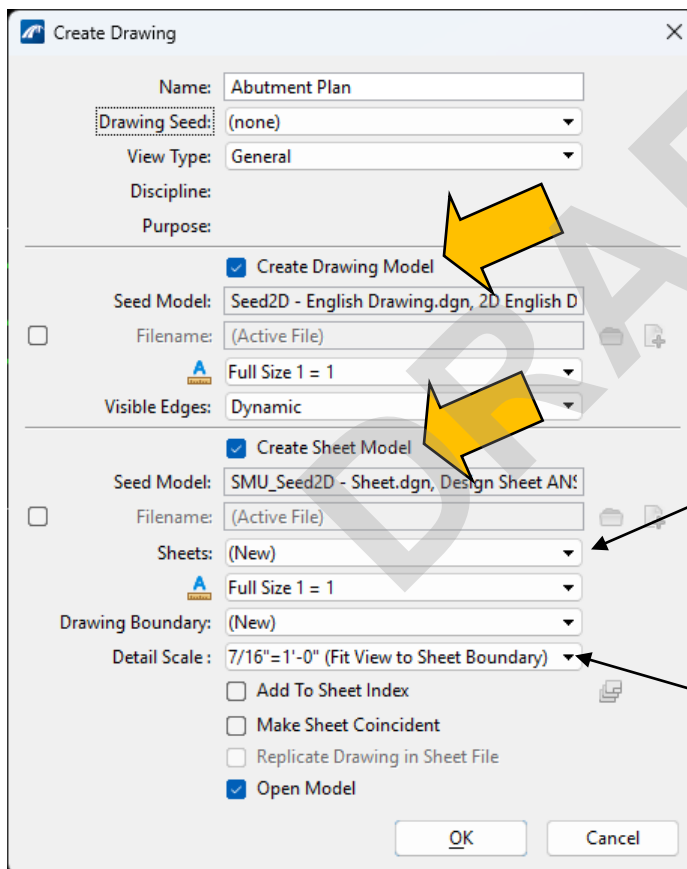

Note: If a Sheet Model has already been created for the DGN, use the drop down to select the sheet model you want the drawing to appear on.

The detail scale is auto generated trying to fit the fenced area into the pre-determined box on the SMU plan sheet. This can be adjusted later if need be.

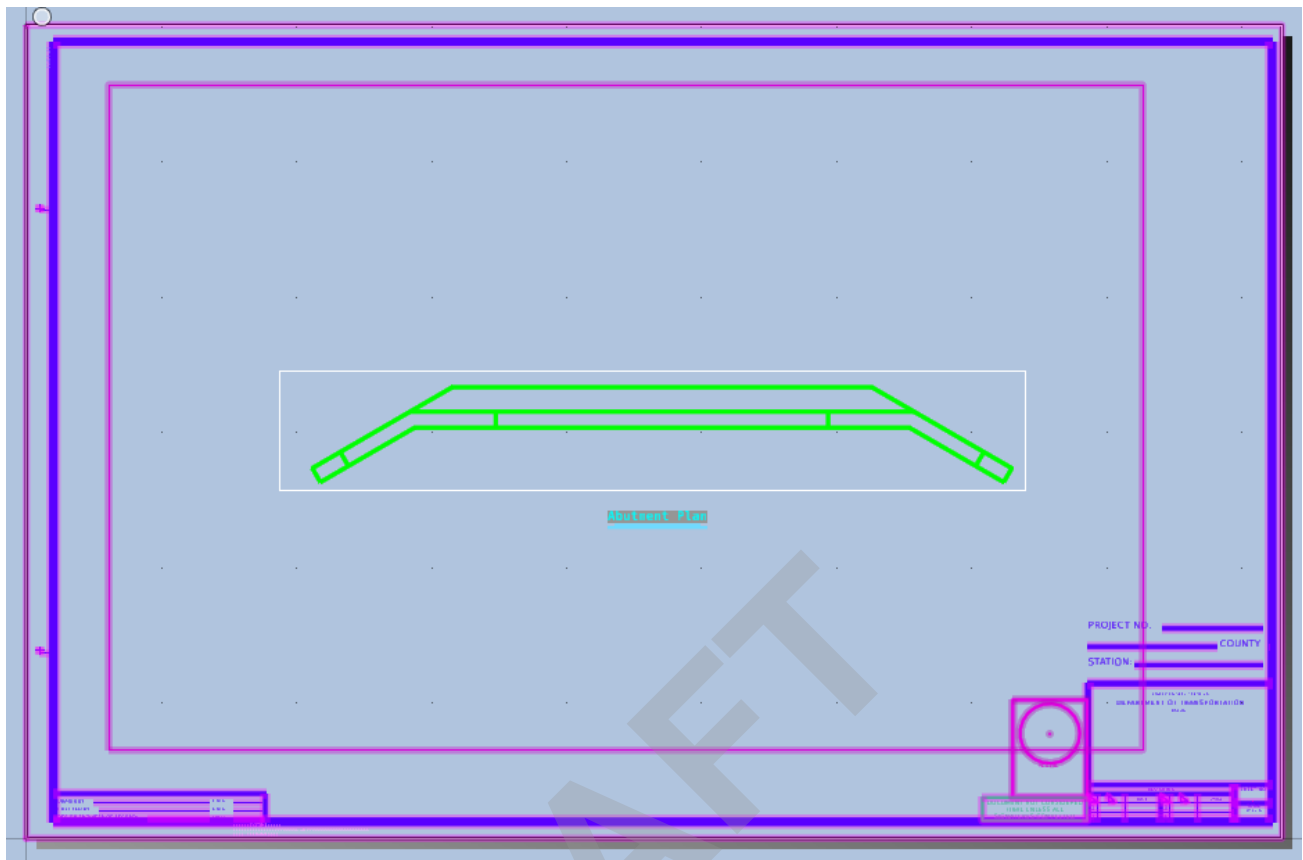

The placed named boundary item can be moved and scaled up or down on the plan sheet using the References tool.

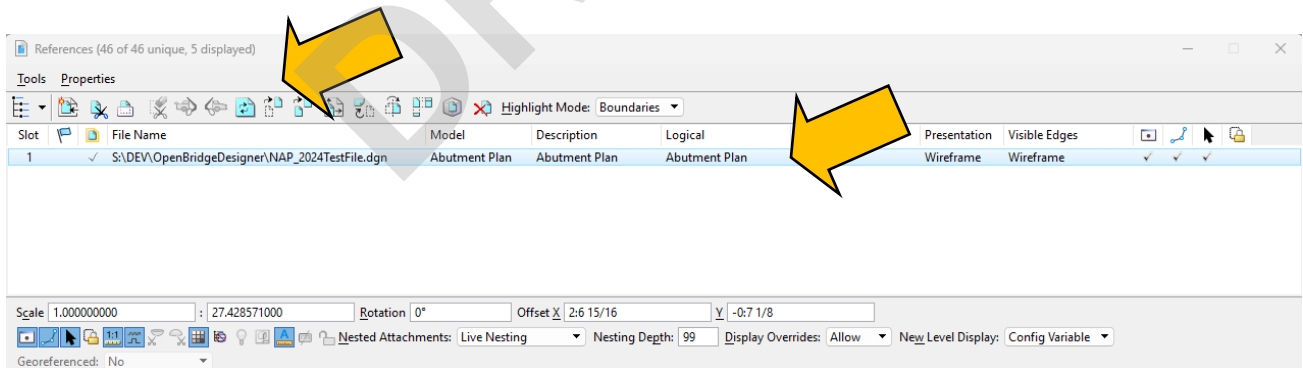

Once the element is at the scale that works for the plan sheet, the element can be annotated in the Drawing Model. Note, set the drawing scale in the Drawing Model to the scale used for the placed named boundary in the Sheet Model.

Name	Model
Default	Default
Abutment Plan [Sheet] Views	Abutment Plan [Sheet]
Abutment Plan Views	Abutment Plan

In the Drawing Model, detail reinforcing steel and annotate the drawing.

In the Sheet Model, place notes using the SMU NOTES app and detail cells.

7.4.2 3D Models to 2D Plans

Use the 3D model DGN created following the steps laid out in Chapter 7 to create a 3D structure model. Once the 3D structure model has been created, a DGN will need to be created for each required 2D superstructure plan sheet.

Reports and Drawings > Drawings > Substructure

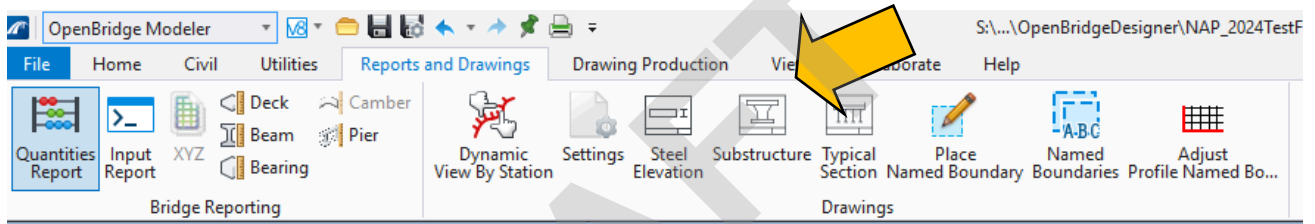

Select the substructure item, and accept the selection.

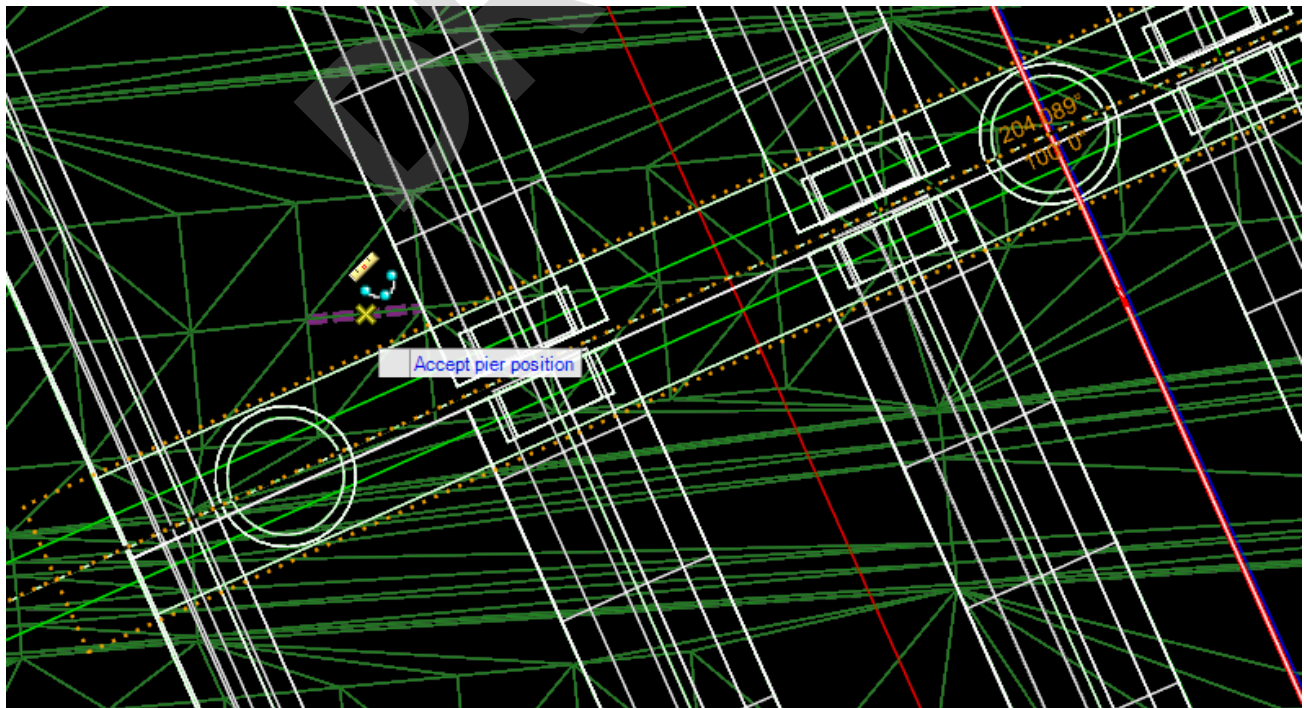

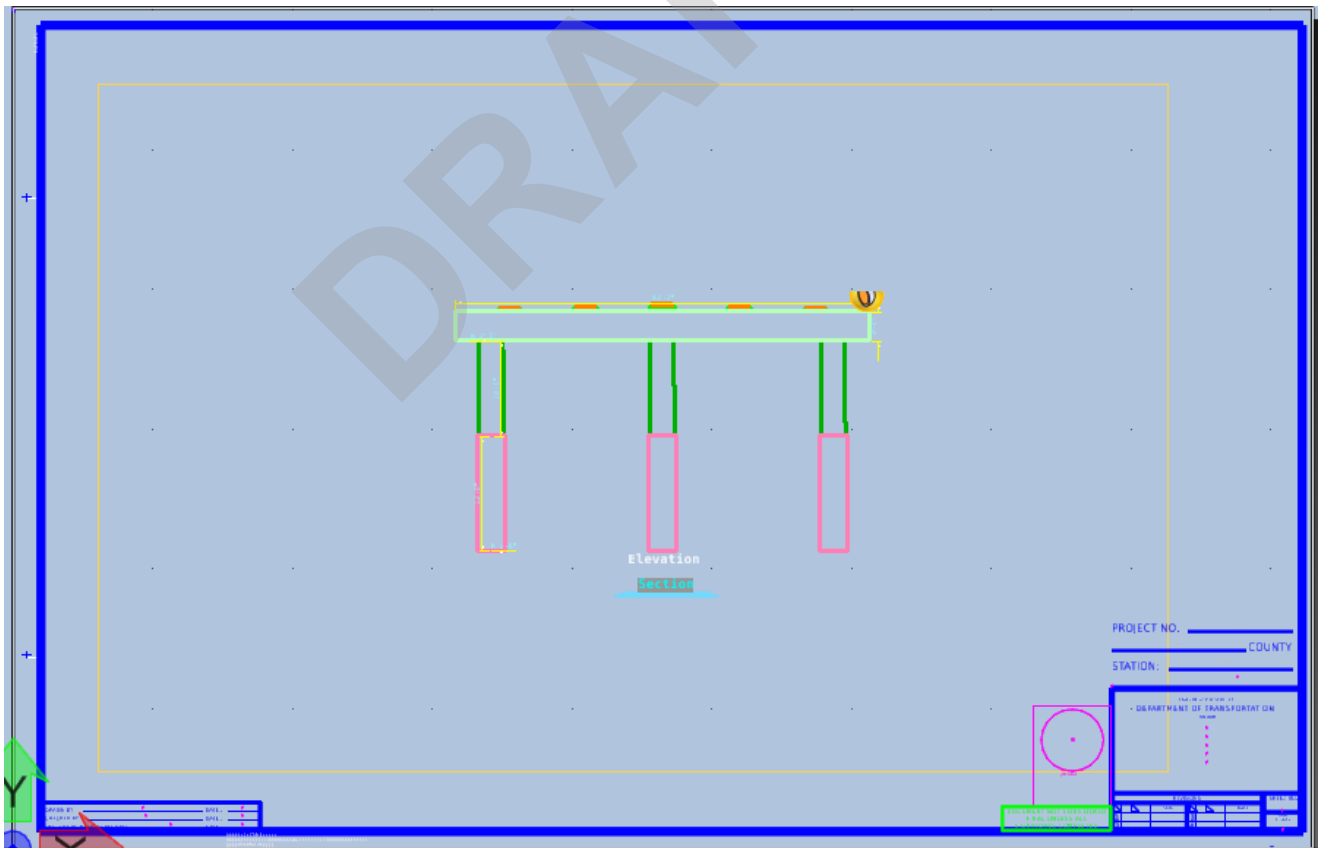
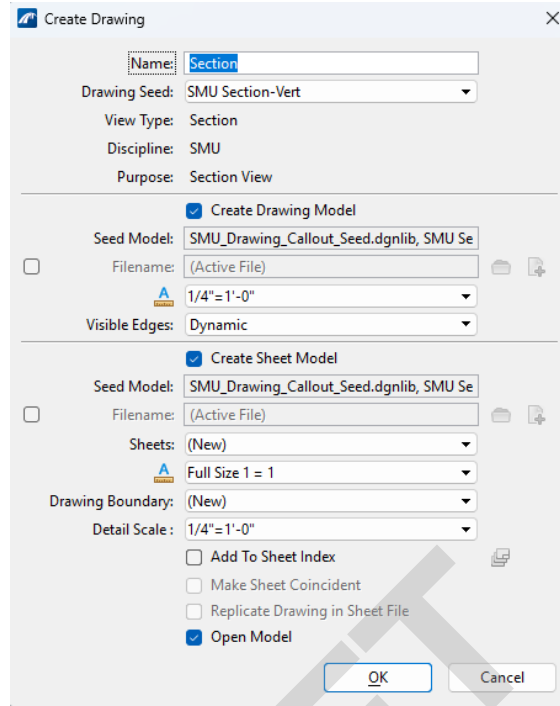

The typical section can be moved and scaled up or down on the plan sheet using the References tool.

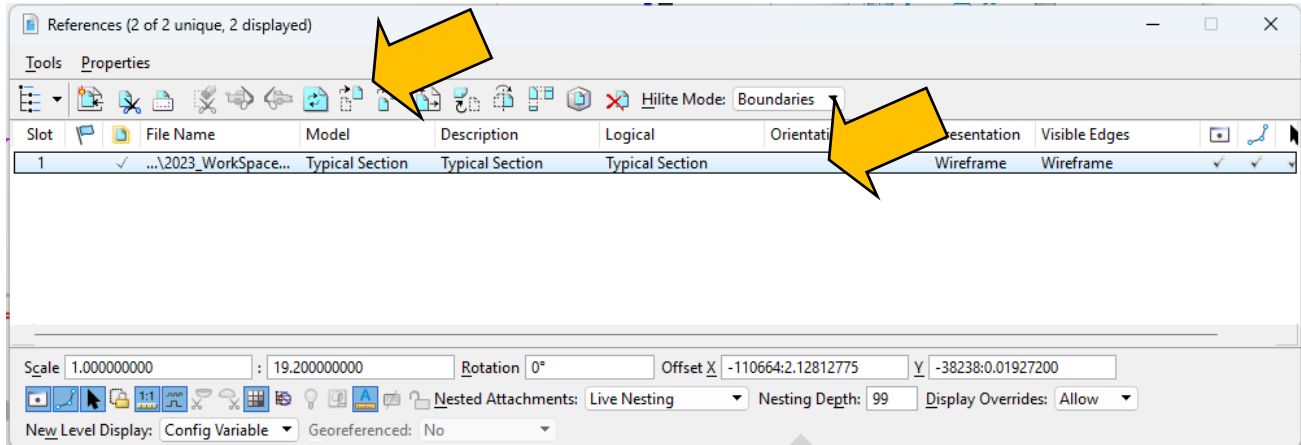

Once the element is at the scale that works for the plan sheet, the element can be annotated in the Drawing Model. Note, set the drawing scale in the Drawing Model to the scale used for the placed named boundary in the Sheet Model.

In the Drawing Model, detail reinforcing steel and annotate the drawing.

In the Sheet Model, place notes using the SMU NOTES app and detail cells.

DRAFT

7.5 SMU STANDARD DRAWINGS & PLANS

SMU Standard Drawings and Plans are available on the SMU website for external users and on the SMU server for internal users to download to the project folder. Once downloaded to the project folder, they can be referenced into the Sheet Model of the DGN.

Structure standard drawings and plans should be their own DGN files within the project, named according to Section 2.3, where they can be edited as needed.

The Drawing Scale of the Sheet Model will need to be changed from “Full Size 1=1” to match the scale noted above the referenced drawing.

At this point in time many of the standard drawings and plans contain outdated fonts and levels, SMU will update these features as standards are revised. Users are **not required to update** standard drawing content to current workspace fonts and levels within the drawing’s field, only the title block content to match other plan sheets within a plan set. Each standard drawing used should be its own DGN file set to the scale noted above the plan sheet.

7.5.1.1 SMU Standards in the Default Model

Older Standard Drawings and Plans could still have the required plan sheet in the Default Model of the DGN. To use those DGN’s, take the following steps.

Create a DGN following the file naming convention in Chapter 2. Once the DGN has been created, create a Sheet Model as shown in Section 3.7.1.3.

In the Sheet Model, go to the **Home tab > Primary ribbon > Attach Tools > References**

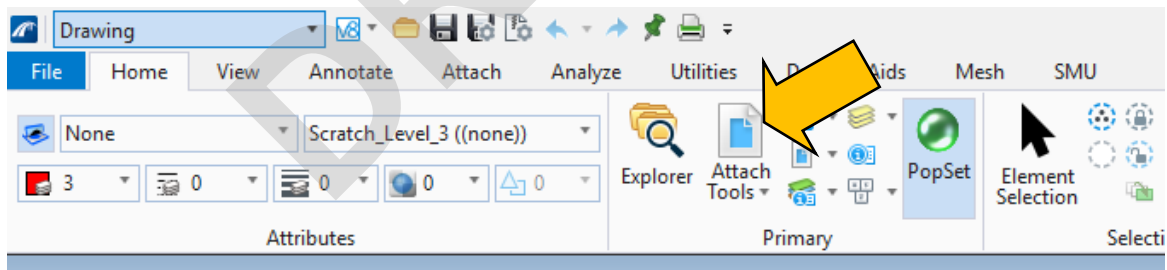

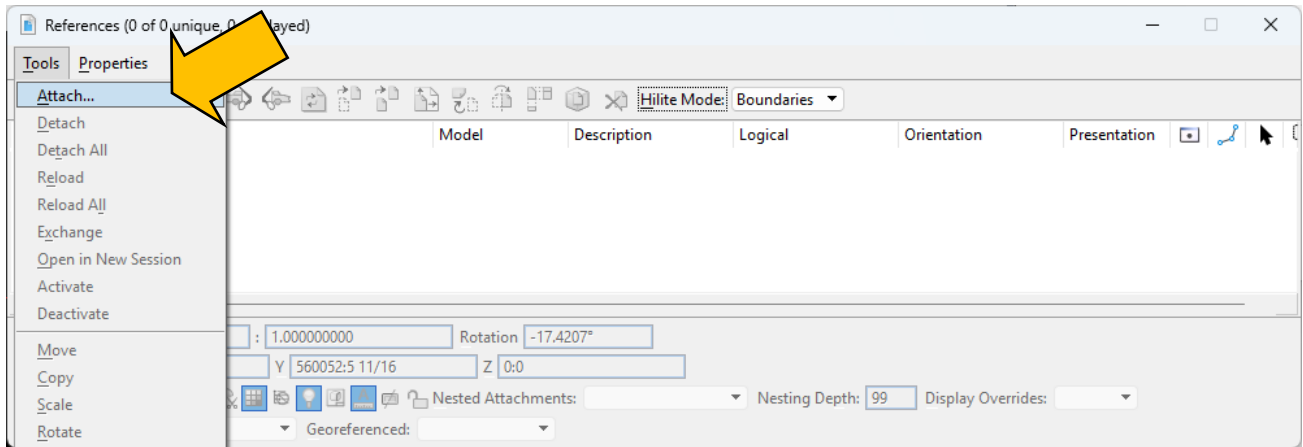

Find and attach the Standard Drawing/Plan sheet into the Sheet Model.

The standard drawing might come into the Sheet Model at a different scale from the ANCI D sheet.

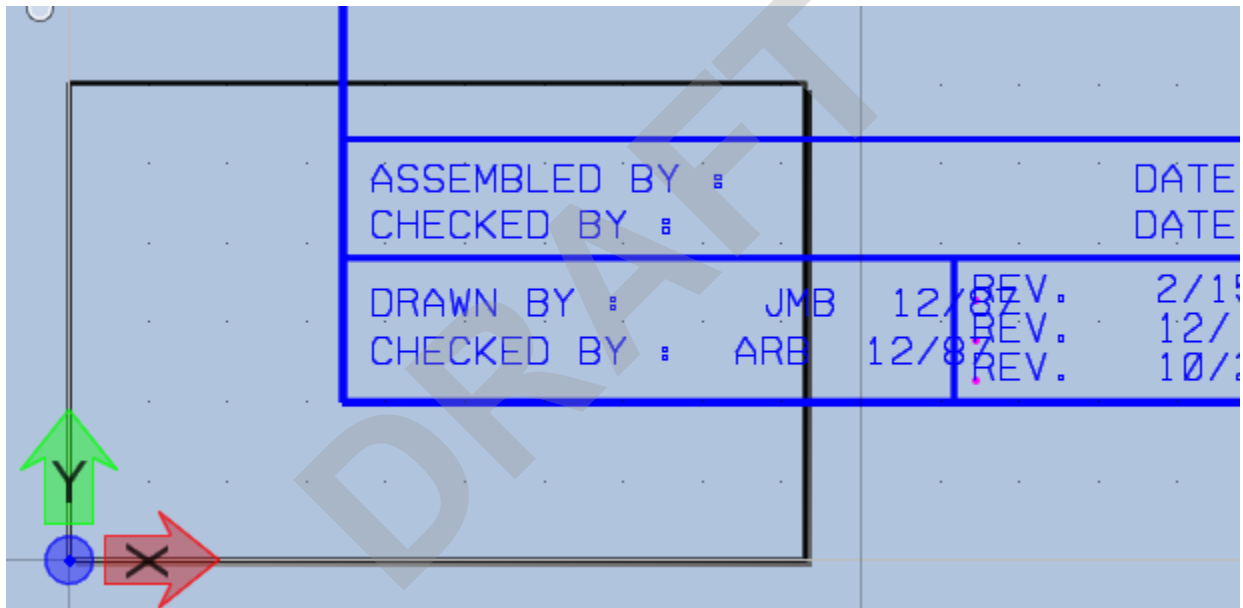

Check the top of the referenced standard to find what the referenced drawing scale is.

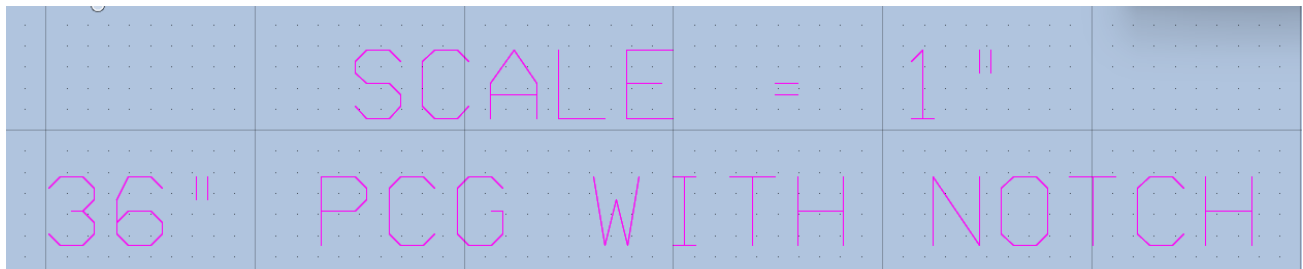

In the Sheet Model, update the drawing scale **Utilities > Drawing Scale** to match the reference.

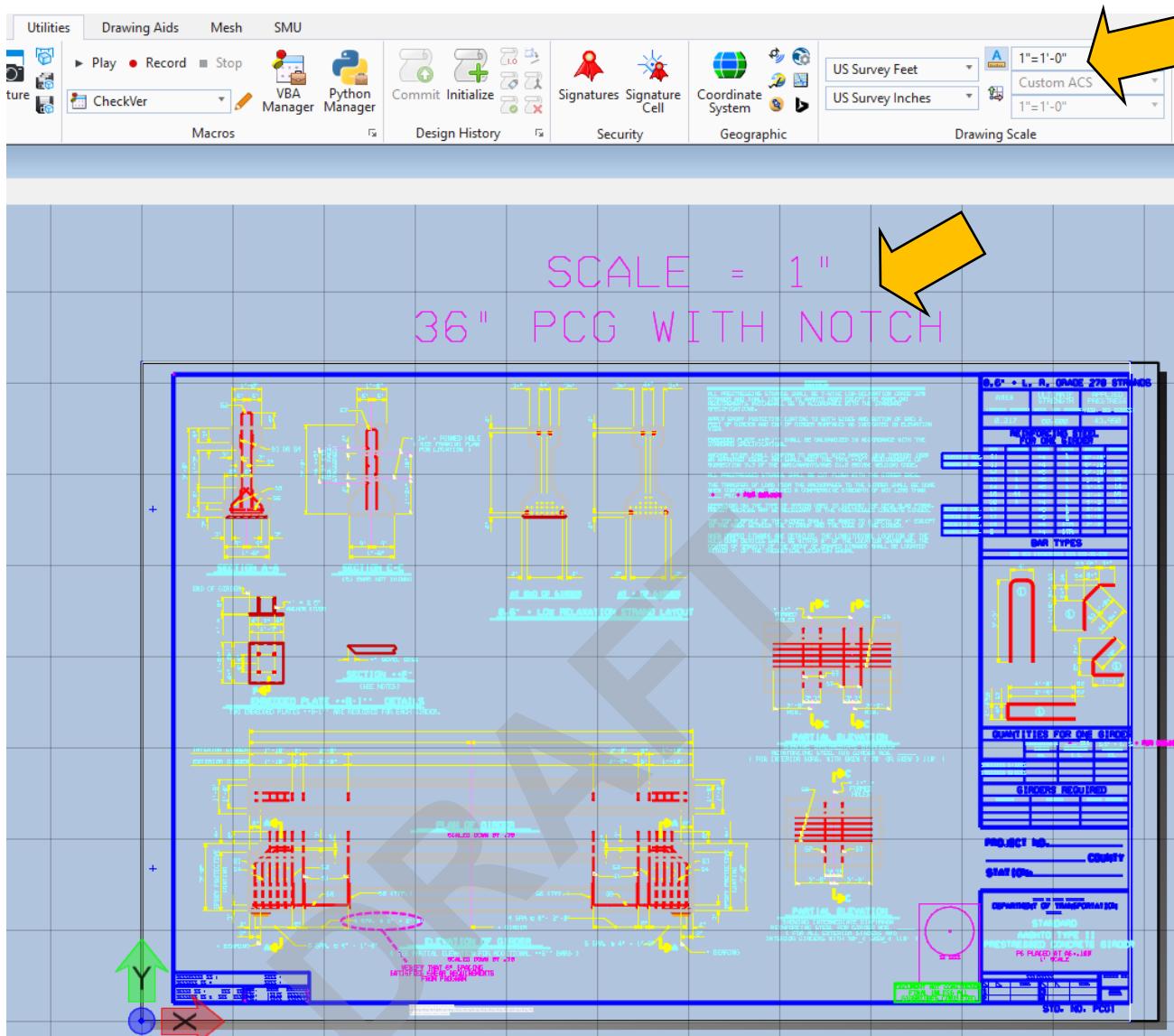

7.5.1.2 SMU Standards in the Sheet Model

Standard Drawing and Plan DGNs that have been updated to the OpenBridge DGN file format have the plan sheet in the Sheet Model of the DGN. To use these DGN's, take the following steps.

Download the Standard Drawing and Plan DGN from the SMU website or server, save the file in the project folder and revise the DGN file name following the naming convention outlined in Chapter 2.

In the Sheet Model, check References for default models turned on for other referenced models turned off.

In the Sheet Model, edit the required fields in the Standard Drawing and Plan as necessary.

CONTENTS

Chapter 8.....8-1

 8.1 2D File Quality Control.....8-1

 8.1.1 File Management.....8-1

 8.1.2 PDF's.....8-1

 8.1.3 DGN's.....8-1

 8.2 3D Model Quality Control.....8-4

 8.2.1 File Management.....8-4

 8.2.2 Bridge Layout.....8-4

 8.2.3 Bridge Deck.....8-5

 8.2.4 Bridge Superstructure.....8-6

 8.2.5 Bridge Substructure.....8-7

 8.2.6 Reports.....8-8

 8.2.6.1 Quantities Report.....8-8

 8.2.6.2 Item Type Reports.....8-10

DRAFT

CHAPTER 8

QUALITY CONTROL & QUALITY ASSURANCE

8.1 2D FILE QUALITY CONTROL

The Drafter of the 2D files needs to create PDF renditions of all DGN files. PDF check plans should be stored in the Plans folder under the structure from which they were generated, along with what percentage review plans they are within the name and metadata. Files should then be assigned to the Checker for review through ProjectWise by the Drafter or a Supervisor.

8.1.1 File Management

The Checker should verify that each plan sheet is its own DGN file as well as each DGN file has the correct file name following the SMU naming conventions and assigned metadata.

Checkers shall notify the Project Manager/Supervisor about files that are not following SMU policies for file management.

8.1.2 PDF's

2D PDF plans should continue to be checked for accuracy as to the structure's design, AASHTO and NCDOT policies and specifications using electronic document review software, such as BlueBeam or Adobe Acrobat.

8.1.3 DGN's

2D DGN files should be assigned and checked at the same time as the PDF's so that comments can be placed on the PDF plan sheet about that sheet's DGN file. The Checker should create their own DGN file and reference the original DGN files in to review it. DGN files should be checked for correct use of SMU element templates, line styles, and annotation styles.

Level Display Tool



A quick way to see if the correct element templates have been used is to check the “Level Display” tool. Using this tool, a Checker can quickly see if the levels used make sense for the DGN being checked. For example, if checking an End Bent plan sheet does the “SMU_End Bent Cap Lines” level appear in the list as being used?

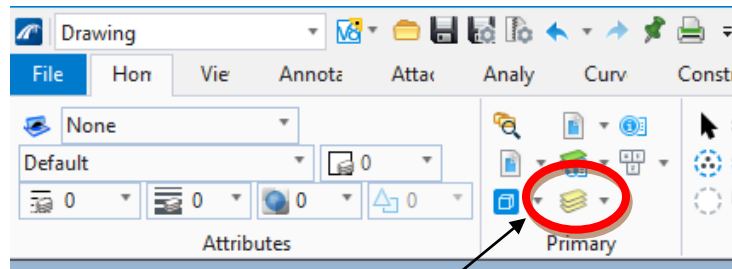

Select the “Level Display” tool



Check the “Used” Levels for use of appropriate levels for the element(s) drawn. Levels used in the file have a “dot” next to them, un-used do not.

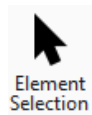

Element Selection Tool

Another way to check a dgn for correct element template usage is to use the element selection tool. Select the Element Selection tool and hover over elements within the dgn to see what level they are on. Verify the levels match the element drawn.

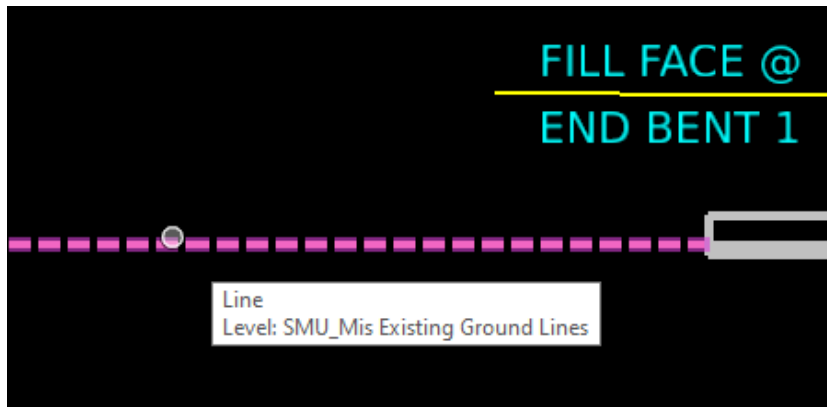

Measurement Tools

The measurement tools, under the “Analyze” tab, can be used inside the DGN to verify element dimensions.

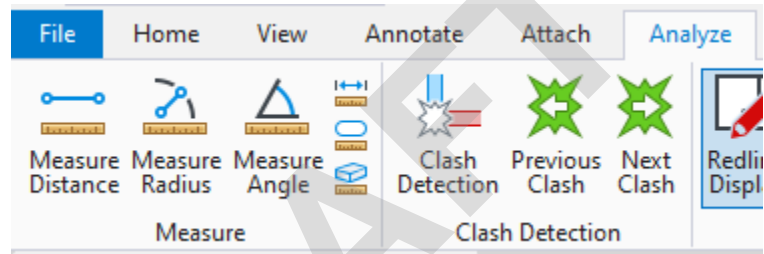

8.2 3D MODEL QUALITY CONTROL

The first step in reviewing the 3D model is to know the level of detail (LOD) to which the model is supposed to be detailed to. The next step is for the Drafter or Supervisor to create a copy of the model and name it **4XX_QC#_TIP#_SMU_BR#_MODEL_6digitStrID** and assign the file to the designated Checker. If the structure is large or if the review is to be broken up into superstructure and substructure reviews, create multiple QC copies of the model changing the QC# in the name and assign the QC versions to the designated checkers. Checkers will need to check, but not limited to, the following items.

8.2.1 File Management

The Checker should verify that the 3D model DGN follows the SMU naming conventions and has been assigned metadata. All 2D plans DGNs created from the 3D model should also follow the SMU naming convention and have metadata assigned.

Checker shall notify the Project Manager/Supervisor about files that are not following SMU policies for file management.

8.2.2 Bridge Layout

The structure layout QC is a macro check against the design, AASHTO and NCDOT policies and specifications. The Checker will need to verify:

- Support Line stations

View 1 (plan view) shows the support line stations.



- Support Line skew angles

Click on the support lines and clicking on the “Properties” icon.

Name	SupportLine 1
Description	
Feature Definition	Supportline
Length	100' 0"
Station	1+00.0000
Direction Mode	Skew
Direction	90.0000°
Skew	0.0000°
> Start Point	<input type="checkbox"/> 100:0,-50:0

- Horizontal Clearance clashes to roadways, rail roads, utilities, etc.
- Vertical Clearance clashes to roadways, rail roads, etc.

8.2.3 Bridge Deck

The Checker will use the steps in Sections 6.5.1 and 6.5.6 of this manual to review the bridge deck element properties using the same tools as editing them.

The deck should be checked against the design for:

LOD 300

- Feature Definitions
- Deck Materials

Verify:

- Deck width
- Deck thickness
- Haunch width
- Haunch thickness
- Left overhang width
- Right overhang width
- Left gutterline offset from proposed -L-
- Right gutterline offset from proposed -L-
- Rail Section properties
- Left rail offset from left outside deck edge
- Right rail offset from right outside deck edge

LOD 350 (LOD 300 plus the following)

- Reinforcing steel size
- Reinforcing steel spacing/layout (includes clearances)
- Reinforcing steel bar lengths
- Reinforcing steel bar splices

LOD 400 (LOD 350 plus the following)

- Prestressing strand sizes
- Prestressing strand spacing/layout

8.2.4 Bridge Superstructure

The Checker will use the steps in Sections 6.5.2, 6.5.3 and 6.5.7 of this manual to editing element properties as a way to review the superstructure elements. The superstructure elements should be checked against the design for:

LOD 300

- Girder section properties
- Girder lengths
- Girder end offsets/clearances
- Girder spacing
- Diaphragm locations
- Diaphragm section properties
- Bearing locations on girders
- Bearing dimensions

LOD 350 (LOD 300 plus the following)

- Girder reinforcing steel sizes
- Girder reinforcing steel spacing/layout (includes clearances)
- Girder reinforcing steel splice lengths
- Girder shear stud sizes
- Girder shear stud spacing

LOD 400 (LOD 300 plus the following)

- Girder prestressing strand sizes
- Girder prestressing strand spacing/layout (includes clearances)

8.2.5 Bridge Substructure

The Checker should use steps shown in Sections 6.5.4, 6.5.5 and 6.5.8 of this manual for editing substructure elements as a way to review the substructure elements. The substructure elements should be checked against the design for:

LOD 300

- Cap Dimensions
 - Length
 - Height
 - Width
 - Overhangs with Columns/Piles
 - Bearing edge distances
- Bridge Seats
 - Bearing edge distances
 - Seat width
 - Seat height
 - Seat Elevations
- Columns/Piles
 - Size
 - Spacing
 - Lengths
- Footings
 - Spacing
 - Lengths/Widths/Height
- Elevations (top of cap, footings, pile tips, etc.)

LOD 350 (LOD 300 plus the following)

- Caps/Bridge Seats/Columns/Piles/Footings Reinforcement
 - Bar Sizes
 - Bar Spacing/Layout (includes clearances)
 - Bar Lengths
 - Bar Splices

LOD 400 (LOD 300 plus the following)

- Caps/Bridge Seats/Columns/Piles/Footings Prestressing
 - Bar Sizes
 - Bar Spacing/Layout (includes clearances)

8.2.6 Reports

When checking 3D models, the Bridge Reporting tools should be used to verify the structure's element properties such as quantities and elevations from the model. The reporting tools can be found here:

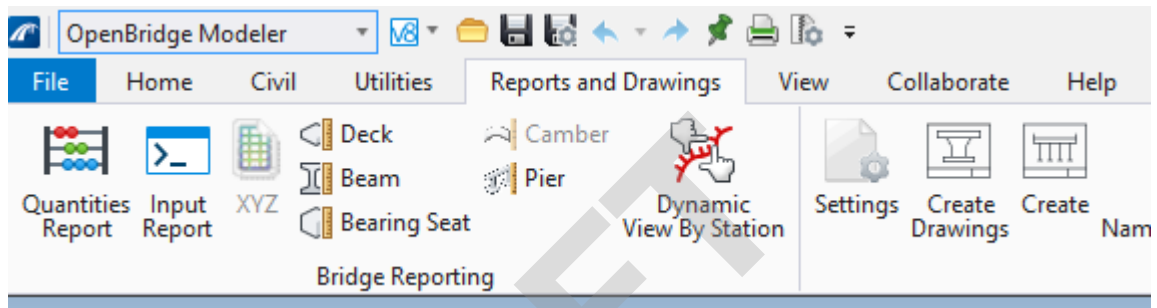

Checkers should continue to use NCBDS, spreadsheets, and other tools that are currently used to verify structure designs, layouts, and quantities.

8.2.6.1 Quantities Report

To generate a quantities report, go to **Reports and Drawings > Bridge Reporting > Quantities Report**

Select the parameters:

- Bridge: Active
- Unit: Active
- Unit/cost data: Disable

Note: SMU will not be maintaining the cost data in the OBD library, only the pay items.

Parameters

Selected Bridge: Active

Selected Unit: Active

Hide Unit/Cost Data

Hide Cost Chart

Accuracy: 1/16

Reset Submit

Click **Submit** once the parameters are selected to generate the report.

Bridge Name: 911473

Bridge Unit: BU01 :: Beam Slab Steel-Girders Bridge

Materials Quantity Report

Superstructure Quantities

Component Name	Component Type	Material Name	Material Type	Pay Unit	Quantity
Deck1	Deck (Timber)	Timber Deck System	Undefined	Cubic Yard	29 5/8

Substructure Quantities

Component Name	Component Type	Material Name	Material Type	Pay Unit	Quantity
Abutment1	Stem and Back Wall	Class A Concrete (Bridge)	Concrete	Cubic Yard	39 5/16
	Footing	Class A Concrete (Bridge)	Concrete	Cubic Yard	29 5/8
Pier1	Cap	Class A Concrete (Bridge)	Concrete	Cubic Yard	16 7/16
	Columns	None	Undefined	Cubic Yard	108 3/8
	Footing	Class A Concrete (Bridge)	Concrete	Cubic Yard	124 13/16
Pier2	Piles	None	Undefined	LF	420.0
	Cap	Class A Concrete (Bridge)	Concrete	Cubic Yard	16 7/16
	Columns	None	Undefined	Cubic Yard	108 3/8
	Footing	Class A Concrete (Bridge)	Concrete	Cubic Yard	124 13/16
Abutment2	Stem and Back Wall	Class A Concrete (Bridge)	Concrete	Cubic Yard	39 5/16
	Footing	Class A Concrete (Bridge)	Concrete	Cubic Yard	29 5/8
	Piles	None	Undefined	LF	420.0

Miscellaneous Quantities

Component Type	Template or Type	Material Name	Pay Unit	Quantity
Barrier	TIMBER RAIL LT 42'	Timber Bridge Rail System	LF	119 5 13/16
	TIMBER RAIL RT 42'	Timber Bridge Rail System	LF	120 6 3/16

Bridge Deck Area, Square Foot 2399.428809762398032

Note that elements where materials were not assigned display “None” in the quantities report.

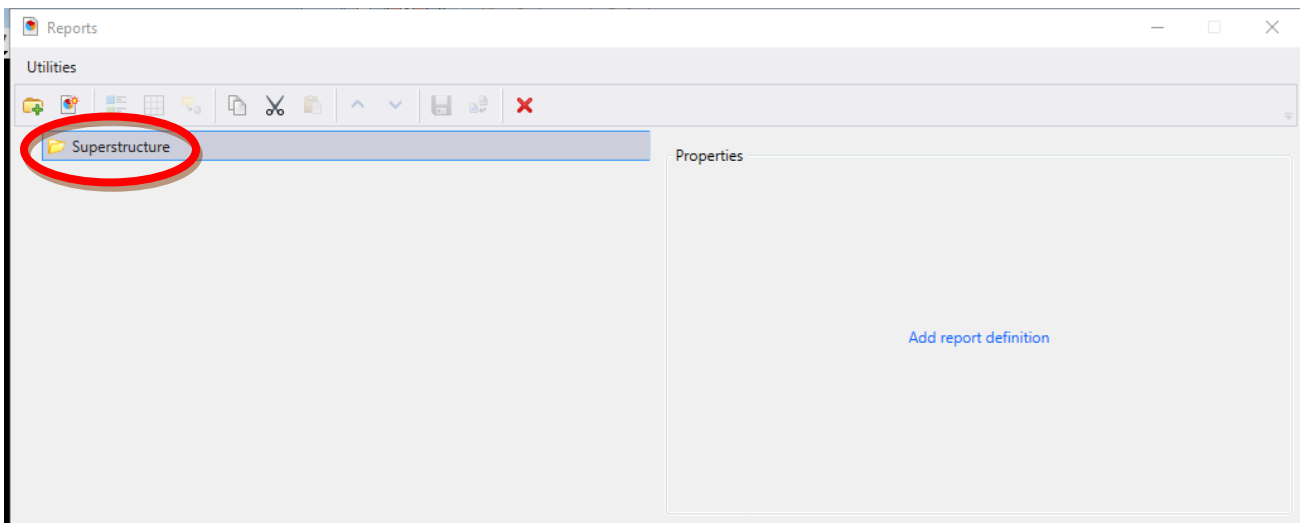

Give the new Category a name.

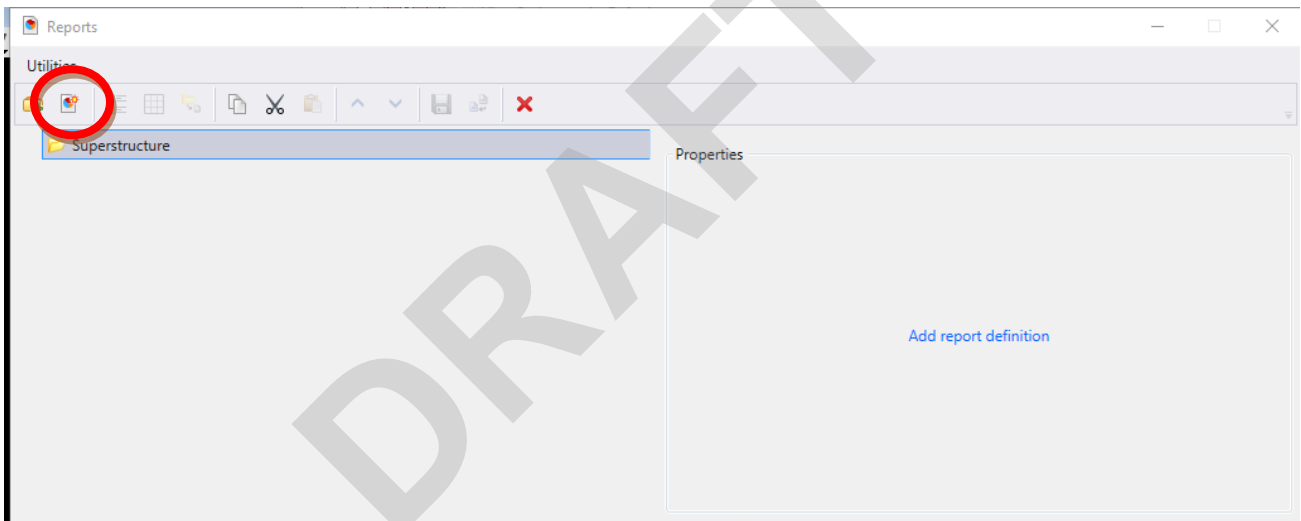

To add report definition, find the New report definition icon on the ribbon.