

# 4.1

## Section

### Best Management Practices (BMP) Symbology\*



Clean Water Diversion

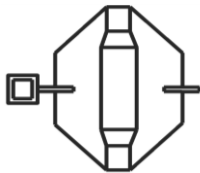

Earthen Dam with Skimmer

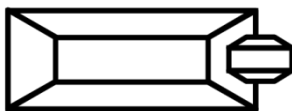

Infiltration Basin



Jurisdictional Flagging

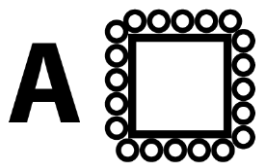

Rock Inlet Sediment Trap, Type A

## 4.1 BMP Symbology

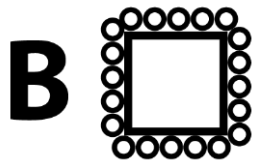

Rock Inlet Sediment Trap, Type B

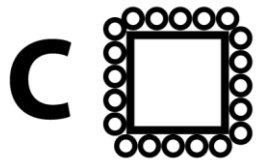

Rock Inlet Sediment Trap, Type C



Rock Pipe Inlet Sediment Trap, Type A



Rock Pipe Inlet Sediment Trap, Type B



Safety Fencing



Silt Basin, Type B

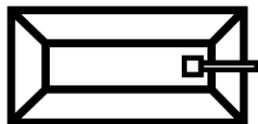

Skimmer Basin



Special Sediment Control Fence

## 4.1 BMP Symbology



Special Sediment Control Fence Break

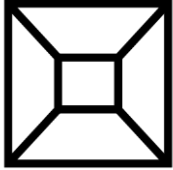

Special Stilling Basin

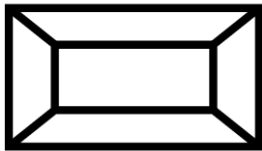

Stilling Basin



Temporary Diversion



Temporary Earth Berm

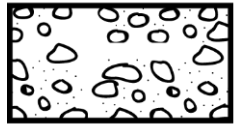

Temporary Rock Sediment Dam, Type A



Temporary Rock Sediment Dam, Type B



Temporary Rock Silt Check, Type-A



Temporary Rock Silt Check, Type A with Excelsior Matting and Flocculant

## 4.1 BMP Symbology



Temporary Rock Silt Check, Type B



Temporary Silt Ditch



Temporary Silt Fence

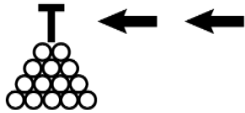

Temporary Slope Drain

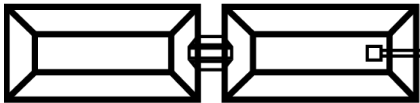

Tiered Skimmer Basin



Wattle Break (Coir Fiber)



Wattle Break (Excelsior)

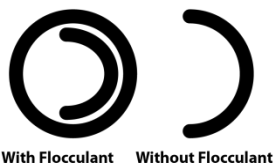

Wattles (with and without flocculant)

\* Some BMPs do not have a standard specification, project special provision, detail drawing number or symbol assigned to them. If a BMP is not listed on this symbology page, there is no symbol for that BMP type.

# 4.2

## Section Site Preparations

<b>Gravel Construction Entrance</b>	<b>4.2.1</b>
<b>Safety Fence and Jurisdictional Flagging</b>	<b>4.2.2</b>

Site preparations within a construction site must be considered early in the planning phase. From stabilizing the entry to protecting unique landscape features and areas of special water quality concern, site preparations are valuable to the designer, technicians and contractors in preserving and maintaining the site conditions.

Gravel construction entrances must be established in order to stabilize access areas.

Areas of special water quality concern require additional planning considerations and more aggressive use of BMPs. Safety fence and jurisdictional flagging must be considered in the early planning phases and applied in the construction phase in order to delineate and help protect these areas. Other areas within the project site that need special attention must also be protected with a safety fence or delineated with jurisdictional flagging.

## 4.2.1 Gravel Construction Entrance (1607.01)



### Definition

A gravel construction entrance is a graveled area where vehicles enter and exit a construction site. The entrance consists of a gravel pad underlined with geotextile. The graveled construction entrance provides a buffer area for the deposition of mud and sediment associated with construction vehicles exiting the site onto adjacent public roadways.

### Areas of Use

- Install gravel construction entrances at all points of ingress and egress from the construction site. Entrances should be provided for the areas used by construction vehicles.

### Design Criteria

- Provide a turning radius to accommodate large trucks.
- Locate entrances to provide for utilization by all construction vehicles.
- Locate gravel construction entrances at all points of ingress and egress until the site is stabilized.
- Identify the number and location of construction entrances, as determined by the Engineer.
- Use Class A stone or other coarse aggregate approved by the Engineer.
- Locate and install the construction entrance in a way to prevent vehicles from bypassing the construction entrance when leaving the project site.
- Place filtration geotextile beneath the stone. Stone should be a minimum depth of 8 inches.
- Construct the gravel construction entrance to dimensions of 12-feet wide by 50-feet long.

### Practical Tips

- Install early in construction
- Install at ALL points of ingress and egress from the construction site.
- Refreshing stone or cleaning may be required if gravel construction entrance is not functioning properly.

## 4.2.1 Gravel Construction Entrance (1607.01)

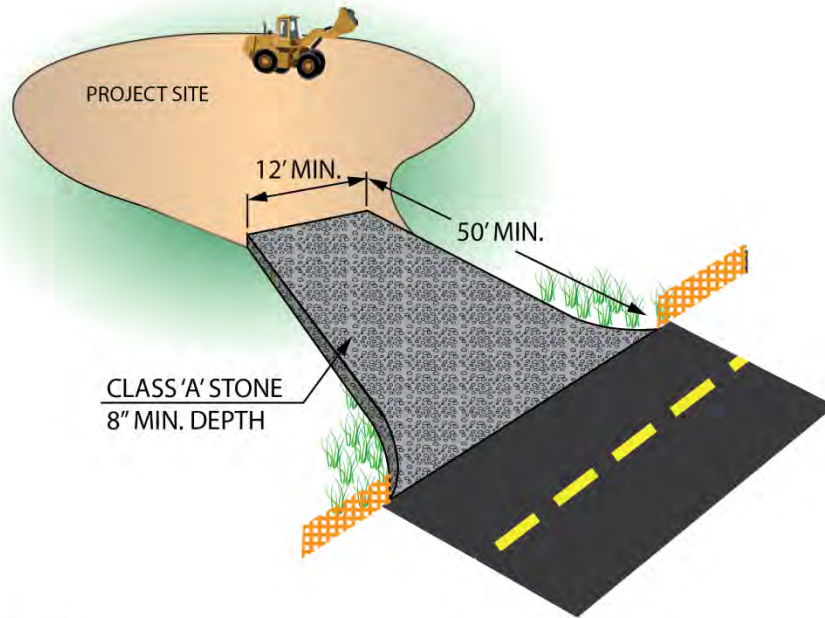

ISOMETRIC VIEW

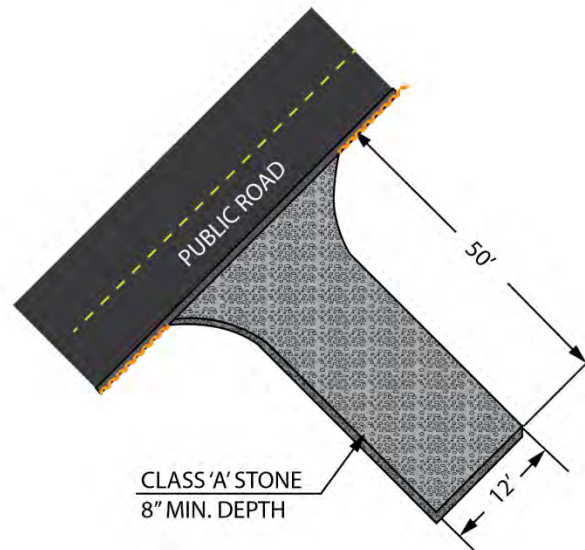

PLAN VIEW

## 4.2.1 Gravel Construction Entrance (1607.01)

### Material Specifications

- Geotextile should meet the requirements of Section 1056 of the Standard Specifications for Type 2 Geotextile.
- Class A, or other approved stone, should meet the requirements of Section 1042 of the Standard Specifications for Stone for Erosion Control, Class A, or other coarse aggregate as directed.

**Class A or other approved stone  
 and Geotextile Type 2**

### Construction Specifications

<b>Geotextile</b>	<ul style="list-style-type: none"> <li>• The stone for the construction entrance shall be Class A placed at a minimum depth of 8 inches, with the geotextile placed under the stone.</li> </ul>
<b>Entrance</b>	<ul style="list-style-type: none"> <li>• The gravel entrance shall be 50-feet long, 12-feet wide, and shall provide turning radii sufficient to accommodate the construction vehicles entering and exiting the construction site.</li> </ul>

**Construction entrances serve to prevent mud from being tracked onto adjacent roadways. They should accommodate larger vehicles and be maintained to function properly.**

### Technician's Checklist

- Install geotextile beneath the stone.
- Maintain the entrance to prevent tracking of mud onto streets. Periodic replacement of stone may be necessary.
- Locate at all points of ingress and egress into the site. Provide frequent checks of the device.
- Install in a manner to prevent vehicles from bypassing the construction entrance when they leave the project site.

### Measurement & Payment

#### Pay Items

#### Pay Units

Geotextile, Type 2

Square Yard

Stone for Erosion Control, Class A

Ton

## 4.2.1 Gravel Construction Entrance (1607.01)

### Maintenance

- The gravel construction entrance must be maintained in a condition to prevent tracking or direct flow of mud onto adjacent roadways.
- Replacement of stone may be necessary to ensure the gravel entrance functions properly.
- Replenishment of stone may be necessary.
- Frequent checks of the device and timely maintenance should be completed.
- Any material tracked onto the roadway shall be cleaned up immediately.

### Typical Problems

- The stone is not installed correctly resulting in vehicle tires not being cleaned effectively.
- Excessive sediment accumulates on the stone.
- The stone is not replenished as necessary to provide a clean entrance for construction vehicles entering adjacent roadways.

## 4.2.1 Gravel Construction Entrance (1607.01)

*This page is intentionally left blank.*

## 4.2.2 Safety Fence & Jurisdictional Flagging



### Practical Tips

- Safety fence and jurisdictional flagging define boundaries and provide a visual cue for identifying the boundaries.
- For safety fencing, wood or steel posts can be used.

### Definition

Safety fence is a polypropylene fence along the perimeter of riparian buffers, wetlands or water boundaries.

Jurisdictional flagging consists of stakes and highly visible flagging that is used to identify interior boundaries for jurisdictional areas such as buffers, wetlands, regulated streams and waters. For more details on jurisdictional areas, refer to Chapter 3.

### Areas of Use

Install safety fence in these locations:

- Along the perimeter of riparian buffers, wetlands and water boundaries
- Along the perimeter of other areas within the project that infringe on buffers, wetlands, endangered vegetation, culturally sensitive areas or waters

Install jurisdictional flagging in these locations:

- Along interior boundaries for jurisdictional areas
- To delineate staging areas, waste sites, or borrow pits whether they are located outside or inside of the jurisdictional boundaries

**Safety Fences should be installed prior to any land disturbing activities.**

## 4.2.2 Safety Fence & Jurisdictional Flagging



### Design Criteria

- No additional clearing and grubbing should be planned for the installation of a safety fence.
- The safety fence should be located on the plans in the field to delineate and bring special attention to buffers, wetlands and water boundaries.

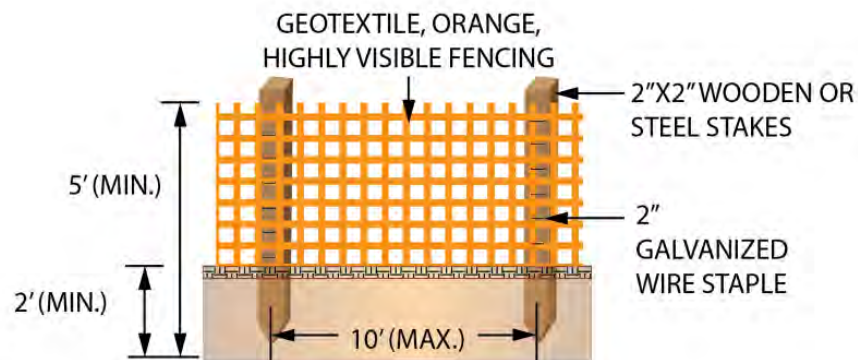

SAFETY FENCE PLAN VIEW (NOT TO SCALE)

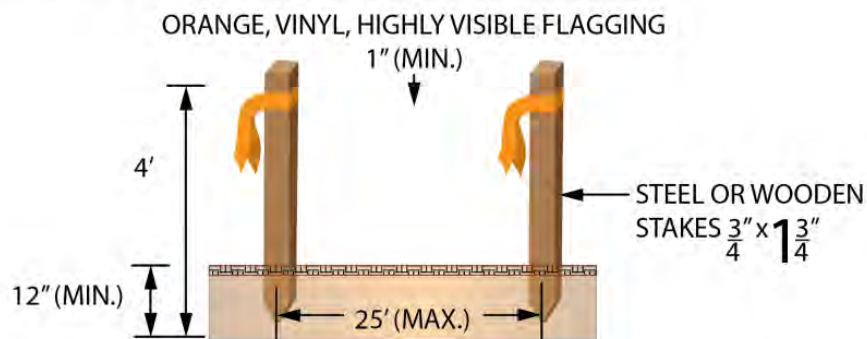

JURISDICTIONAL FLAGGING PLAN VIEW (NOT TO SCALE)

## 4.2.2 Safety Fence & Jurisdictional Flagging



### JURISDICTIONAL FLAGGING PLAN VIEW (NOT TO SCALE)

#### JURISDICTIONAL AREA - RIPARIAN BUFFER ZONE LAYOUT

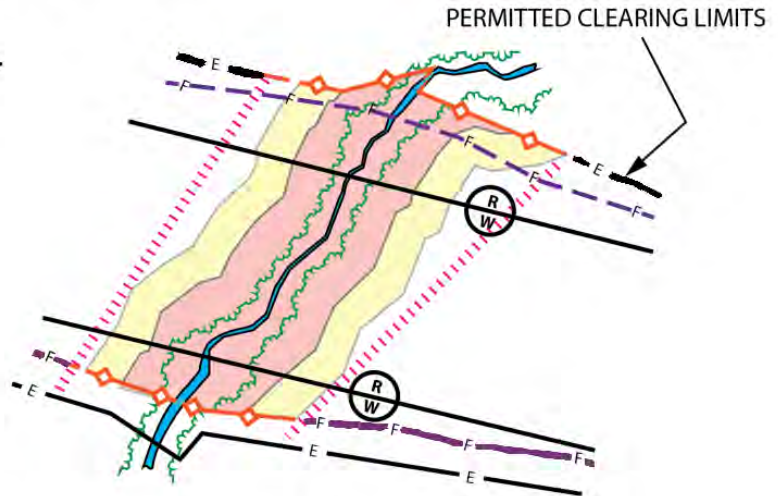

### LAYOUT FOR JURISDICTIONAL AREA - RIPARIAN BUFFER ZONE

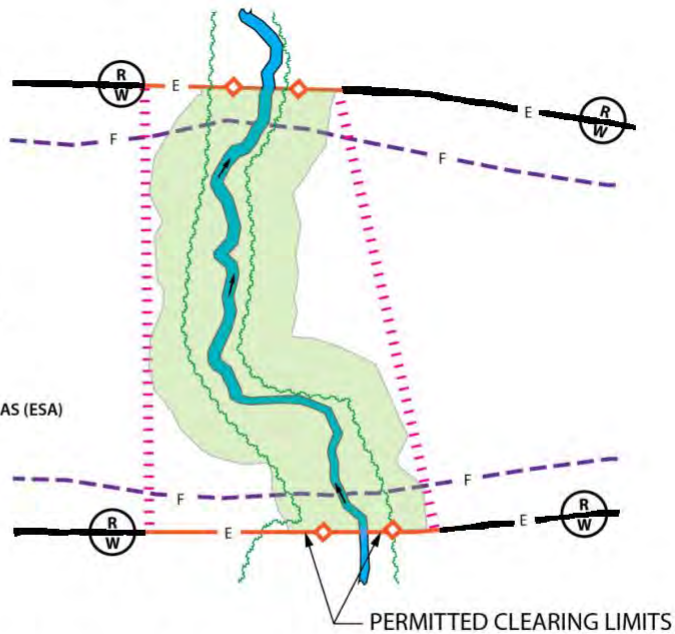

### LAYOUT FOR JURISDICTIONAL STREAM - ESA WITHOUT RIPARIAN BUFFERS

## 4.2.2 Safety Fence & Jurisdictional Flagging

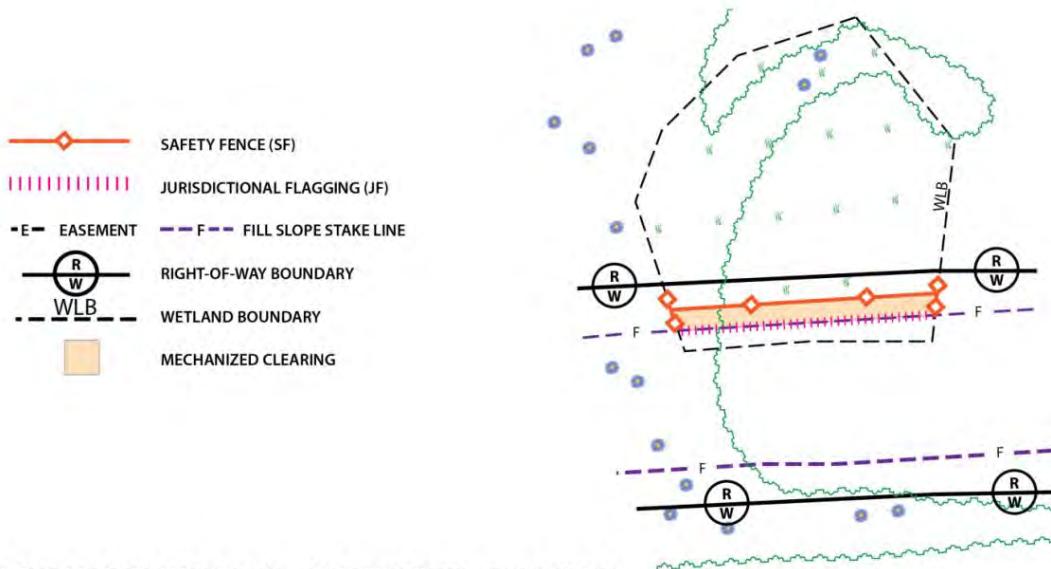

LAYOUT FOR WETLAND - MECHANIZED CLEARING\*

\* - REFER TO PERMIT DRAWINGS FOR JURISDICTIONAL BOUNDARIES

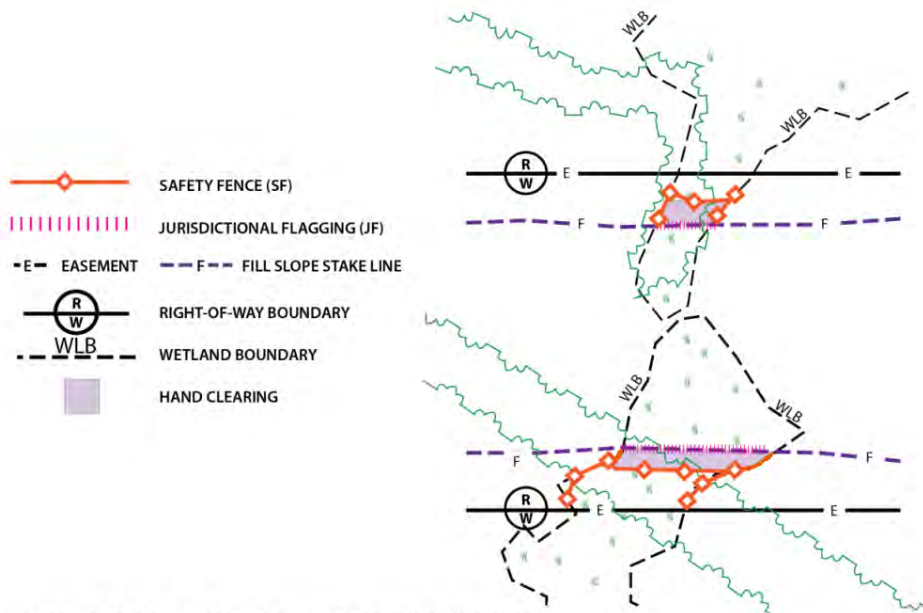

LAYOUT FOR WETLAND - HAND CLEARING\*

\* - REFER TO PERMIT DRAWINGS FOR JURISDICTIONAL BOUNDARIES

## 4.2.2 Safety Fence & Jurisdictional Flagging

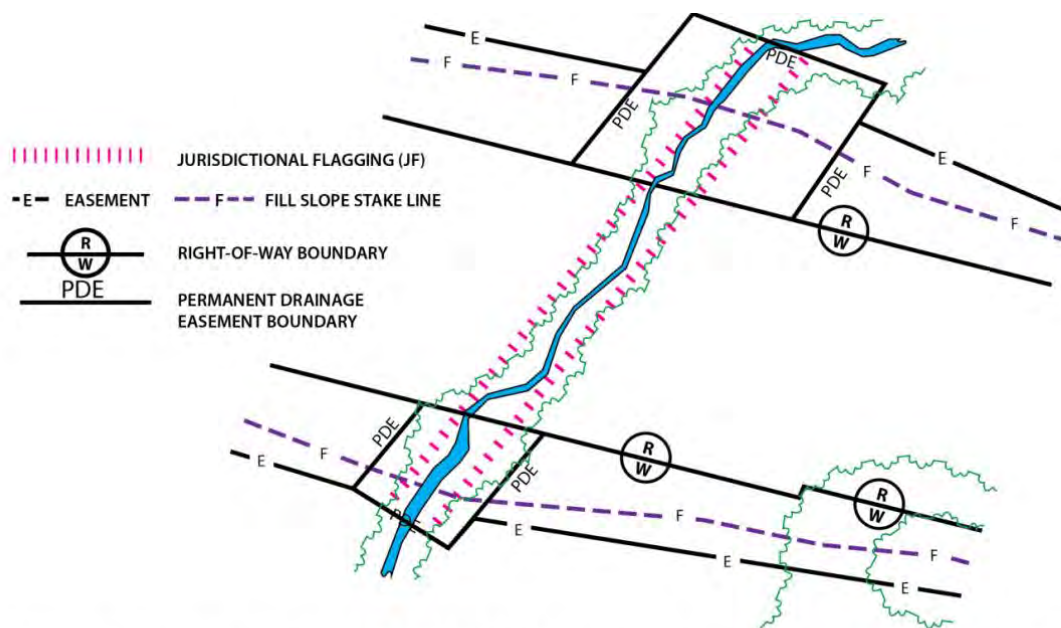

LAYOUT FOR JURISDICTIONAL STREAM - NO HIGH QUALITY WATER (HWQ) / NO BUFFER

### Material Specifications

#### Safety Fence

- The polyethylene or polypropylene fence shall be a highly visible pre-constructed safety fence approved by the Engineer.
- The fence material should have an ultraviolet coating.

#### Jurisdictional Flagging

- Wood stakes should be 4 feet in length with a minimum nominal  $\frac{3}{4}$  inch by  $1\frac{3}{4}$  inch cross section.
- The flagging should be at least 1 inch in width.
- The flagging material should be vinyl and highly visible. Mechanized clearing can be orange in color, but hand-cleared areas should be flagged with a different color to distinguish these areas.

## 4.2.2 Safety Fence & Jurisdictional Flagging



### Construction Specifications

No additional clearing and grubbing is required for the safety fence installation. The safety fence should conform to the general contour of the ground.

### Safety Fence

Posts	<ul style="list-style-type: none"> <li>• Set the posts at a maximum spacing of 10 feet.</li> <li>• Maintain the posts in a vertical position.</li> <li>• Set or hand set the posts with a post driver.</li> <li>• Thoroughly tamp all backfill material if hand set.</li> <li>• Cut the tops of posts at a 30 degree angle. The Contractor can make this cut before or after the post is installed.</li> </ul>
Geotextile	<ul style="list-style-type: none"> <li>• Should be attached to the wood posts with one 2-inch galvanized wire staple across each cable or to the steel posts with wire or other acceptable means</li> </ul>
Stakes	<ul style="list-style-type: none"> <li>• Should be placed to establish the location of the safety fence in accordance with Sections 105-9 or 801-1 of the Standard Specifications</li> </ul>

### Jurisdictional Flagging

Stakes	<ul style="list-style-type: none"> <li>• Place the stakes on a maximum of 25-foot intervals.</li> <li>• Attach highly visible orange flagging.</li> <li>• Install the posts a minimum of 2 feet into the ground.</li> <li>• Stake interior boundaries on a tangent running parallel to the buffer, but do not encroach on the buffer at any location.</li> </ul>
Flagging	<ul style="list-style-type: none"> <li>• Interior boundaries of hand clearing should be identified with a different colored flagging to distinguish them from mechanized clearing.</li> <li>• Flagging should be installed in accordance with Sections 105-9 or 801-1 of the Standard Specifications.</li> <li>• Delineation of jurisdictional boundaries at staging areas, waste sites or borrow pits should be performed in accordance with subsections 230-4(B)(5) or 802-2(F) of the Standard Specifications.</li> </ul>

## 4.2.2 Safety Fence & Jurisdictional Flagging



### Technician's Checklist

- The safety fence and flagging should be inspected regularly and maintained for the duration of the project.
- It is important for the safety fence posts to be buried 2 feet into the ground to provide stability.

**Additional flagging may be placed on overhanging vegetation to enhance visibility, but it does not provide a substitute for the installation of the fence or flagging stakes.**

### Measurement & Payment

#### Safety Fence

Safety fence will be measured and paid as the actual number of linear feet of polyethylene or polypropylene fence installed in place. Such payment will be full compensation and includes furnishing and installing the fence geotextile with the necessary posts, post bracing, staples, tie wires, tools, equipment and incidentals to complete this work.

No direct pay item will be made for the staking of the safety fence. All stakeouts for safety fence should be considered incidental to the work being paid for as "Construction Surveying." If there is no pay item for "Construction Surveying," the safety fence stakeout will be performed by State Forces.

#### Pay Items

Safety Fence

#### Pay Units

Linear Foot

## 4.2.2 Safety Fence & Jurisdictional Flagging



### Jurisdictional Flagging

No direct pay item will be made for the delineation of interior boundaries. The delineation will be considered incidental to the work being paid for as “Construction Surveying.” If there is no pay item for “Construction Surveying,” the delineation should be included in the unit prices bid for the various items in the contract. No direct pay item will be made for delineation of interior boundaries at staging areas, waste sites or borrow pits. The cost for this delineation should be included in the unit prices bid for the various items in the contract.

### Maintenance

- Posts damaged by power driving shall be removed and replaced prior to final acceptance.
- The safety fence and flagging should be maintained in a satisfactory condition for the duration of the project as determined by the Engineer.

### Typical Problems

- The fence geotextile is not properly secured to the posts.
- The fence or flagging is damaged and not repaired or replaced.

# 4.3

## Section

### Perimeter Areas

Temporary Silt Fence	4.3.1
Temporary Diversion	4.3.2
Temporary Silt Ditch	4.3.3
Silt Fence Breaks	4.3.4
Temporary Earth Berm	4.3.5

Perimeter areas require consideration and attention early in the planning phase. BMPs located in perimeter areas are used to divert clean water away from the project site or intercept stormwater runoff.

Temporary silt fence, temporary diversion, temporary silt ditch, silt fence breaks and temporary earth berms are types of BMPs that can be used to protect the perimeter areas of a project site.

## 4.3.1 Temporary Silt Fence (1605.01)



### Practical Tips

- In order for the silt fence to be effective, it is essential to verify that the geotextile is buried in an excavated trench.
- Silt fence should be installed properly, backfilled and compacted well.

### Definition

Temporary silt fence is made of a permeable geotextile buried at the bottom, stretched and supported by steel posts. The silt fence breaks up sheet flow, decreases runoff velocity and allows suspended sediment particles to settle.

### Areas of Use

Install temporary silt fence in the following locations:

- In locations to break up sheet flow and decrease runoff velocities
- Not in areas of concentrated flow
- At the bottom of fill sections to prevent off-site sedimentation

Areas of use for temporary silt fence should have the following considerations:

- Use in areas where runoff can accumulate behind the silt fence without damaging the fence or the inundated area behind the fence
- Locate where only shallow pools will form, as it cannot function properly where there are high levels of water
- Use in wetlands or other buffer areas where the ground water level is near the surface and prohibits the excavation of silt ditches
- Use in areas where the subsurface is not rock or tree roots, so that posts can be driven into the ground and

**Avoid in areas of concentrated flow. Silt fence is commonly relied on exceedingly in erosion and sediment control designs.**

## 4.3.1 Temporary Silt Fence (1605.01)



the geotextile can be trenched into the soil

- Use at the toe of a fill section on a steep slope where topography prohibits silt ditch excavation
- Use in areas where right-of-way or construction easement is limited
- Use in business and residential areas where safety and aesthetics are a concern. Avoid measures in residential areas that will interfere with property owners maintaining their property or present safety concerns. Silt fence can be an alternative measure in these locations.

### Design Criteria

- The drainage area should not be greater than ¼ acre per 100 feet of silt fence.
- The silt fence should be stable for the 10-year peak storm runoff.
- The maximum slope length behind the silt fence should not exceed the specifications shown in the table below.

Table 4.1. Maximum Slope Length Behind Silt Fence	
Slope	Slope Length (feet)
<2%	100
2 to 5%	75
5 to 10%	50
10 to 20%	25
>20%	15

Table 6.62, Erosion and Sediment Control Planning and Design Manual, NCDENR

- The depth of impounded water shall not exceed 1.5 feet behind the fence.
- The silt fence shall not be used alone below graded slopes greater than 10 feet in height.

## 4.3.1 Temporary Silt Fence (1605.01)

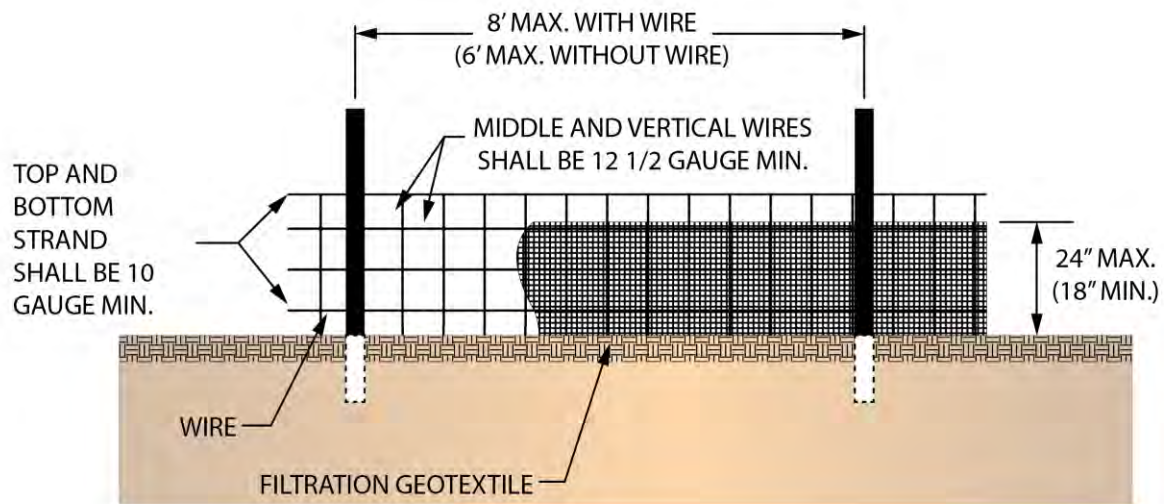

FRONT VIEW

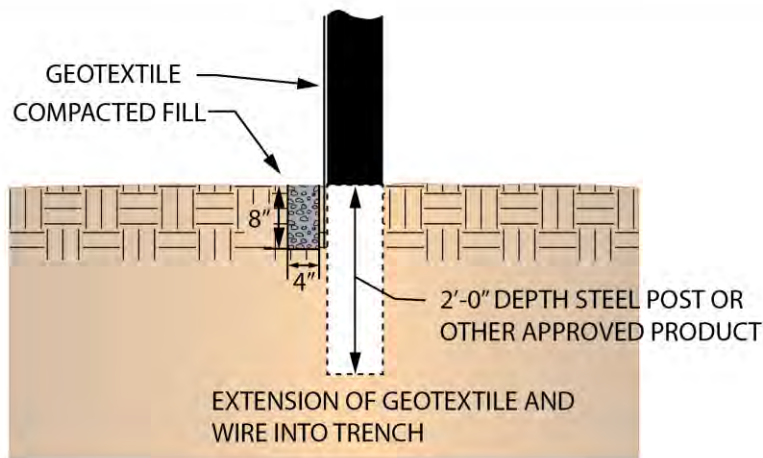

CROSS SECTION

## 4.3.1 Temporary Silt Fence (1605.01)



### Material Specifications

- The geotextile shall meet the requirements of Section 1056 of the Standard Specifications for Type 3 Geotextile.
- Posts shall be steel, or other approved product, and have a minimum length of 5 feet.
- Posts, woven wire and wire staples shall meet the requirements of Section 1605-2 of the Standard Specifications.
- Geotextile shall be a minimum of 36-inches wide.
- Proper geotextile certifications are required to assure adherence to Section 1056 of the Standard Specifications.
- Woven wire shall be a minimum of 32 inches in height and with a minimum of 5 horizontal wires with 12-inch stay spacing.
- Top and bottom strands of woven wire shall be a minimum of 10 gauge, and middle and vertical wires shall be a minimum of 12 ½ gauge.

**Filtration Geotextile: Type 3**

### Construction Specifications

Geotextile	<ul style="list-style-type: none"> <li>• The geotextile shall be buried a minimum 8 inches deep and 4 inches laterally. Soil should be firmly tamped.</li> <li>• Geotextile should be installed a maximum of 18 inches above the ground surface for mechanical slicing method of installation.</li> <li>• The geotextile shall be attached to posts and woven wire by wire or other acceptable means.</li> <li>• The geotextile shall be overlapped a minimum of 18 inches at all splice joints.</li> <li>• The height of the geotextile should not exceed 24 inches above the ground surface.</li> <li>• Each end of the silt fence shall be cut upgradient in a “J” pattern to prevent release of untreated storm flows.</li> </ul>
Posts	<ul style="list-style-type: none"> <li>• Post spacing should be a maximum of 6 feet without woven wire backing and 8 feet with woven wire.</li> <li>• Posts shall be installed so that no more than 3 feet extends above the ground.</li> </ul>

**Temporary silt fence interrupts sheet flows, reduces velocities and allows suspended sediment particles to settle.**

## 4.3.1 Temporary Silt Fence (1605.01)



Prior to installing the silt fence, a trench needs to be excavated so that the geotextile can be buried with compacted soil or gravel backfill. Thorough compaction of the backfill is critical to the performance of the silt fence. Temporary silt fence can be installed with or without a woven wire backing. Periodic inspections and maintenance of the fence will need to be done, especially after each rainfall.

### Technician’s Checklist

- The silt fence should be installed in accordance with the Erosion and Sediment Control Plans.
- In order for the silt fence to be effective, it is essential to verify that the geotextile is buried in an excavated trench.
- In addition to the geotextile being buried, it should be adequately buried with compacted soil backfill to secure the silt fence and keep it in place.
- The silt fence should be inspected for sediment accumulation and repairs on a regular basis and after significant rain events.

### Measurement & Payment

When the accumulated silt is removed along the silt fence, it is paid for as “Silt Excavation.”

#### Pay Items

Temporary Silt Fence  
 Seeding and Mulching  
 Silt Excavation

#### Pay Units

Linear Foot  
 Acre  
 Cubic Yard

### Maintenance

- Inspect the silt fence on a regular basis and after each significant rainfall. Make any repairs immediately.
- Inspect the silt fence to be sure the bottom of the geotextile is keyed in properly.
- At a minimum, remove and dispose of all silt accumulations when depth reaches 1/2 the height of the geotextile. Do not undermine the fence during cleanout.
- Dispose of sediment by hauling it to an approved waste site with appropriate perimeter protection.
- Remove and replace deteriorated or clogged silt fence.
- Replace silt fence removed for access at the end of each day’s operation.
- Install additional posts or wire backing if fence is sagging.

**At a minimum, remove and dispose of all silt accumulations when the depth reaches ½ of the height of the geotextile. Do not undermine during cleanout.**

## 4.3.1 Temporary Silt Fence (1605.01)



### Typical Problems

- The device is installed improperly (bottom of geotextile is not buried properly).
- Failures occur when the device is installed across streams, waterways and other areas which receive concentrated flow.
- Silt accumulates excessively and geotextile becomes clogged with silt particles and other debris.
- The device is knocked down or cut by fallen trees, rocks, equipment, excess water flows or for work access.
- Inadequate access is provided in order to maintain and remove the fence.

## 4.3.1 Temporary Silt Fence (1605.01)



*This page is intentionally left blank.*

## 4.3.2 Temporary Diversion (1630.05)

→ TD →



### Practical Tips

- Can be used in buffer zones in proposed permitted ditches
- Used to divert runoff inside footprint of project to perimeter sediment basins

### Definition

A temporary diversion is an excavated channel with a berm on its lower side that directs runoff into a basin, through a sediment dam or through rock silt checks.

### Areas of Use

Install temporary diversions in these locations:

- Below slopes to divert sediment laden runoff to sediment control devices
- Across unprotected slopes
- At or near the perimeter of construction limits to keep sediment from leaving the site
- As a precursor for areas designated as final drainage channels
- Above disturbed cut or fill slopes to prevent runoff over the exposed slope material
- Across long grades as a break to reduce slope length and reduce the size of drainage areas
- Not in wetland areas unless documented on permits

**Temporary diversions are used in the clearing and grubbing phase. They function to divert sheet flow into sediment control devices.**

### Design Criteria

- Drainage area shall be 10 acres or less
- Grade should be limited to prevent erosive velocities
- Capacity of the temporary diversion should accommodate the peak runoff from a 10-year storm

## 4.3.2 Temporary Diversion (1630.05)

→ TD →

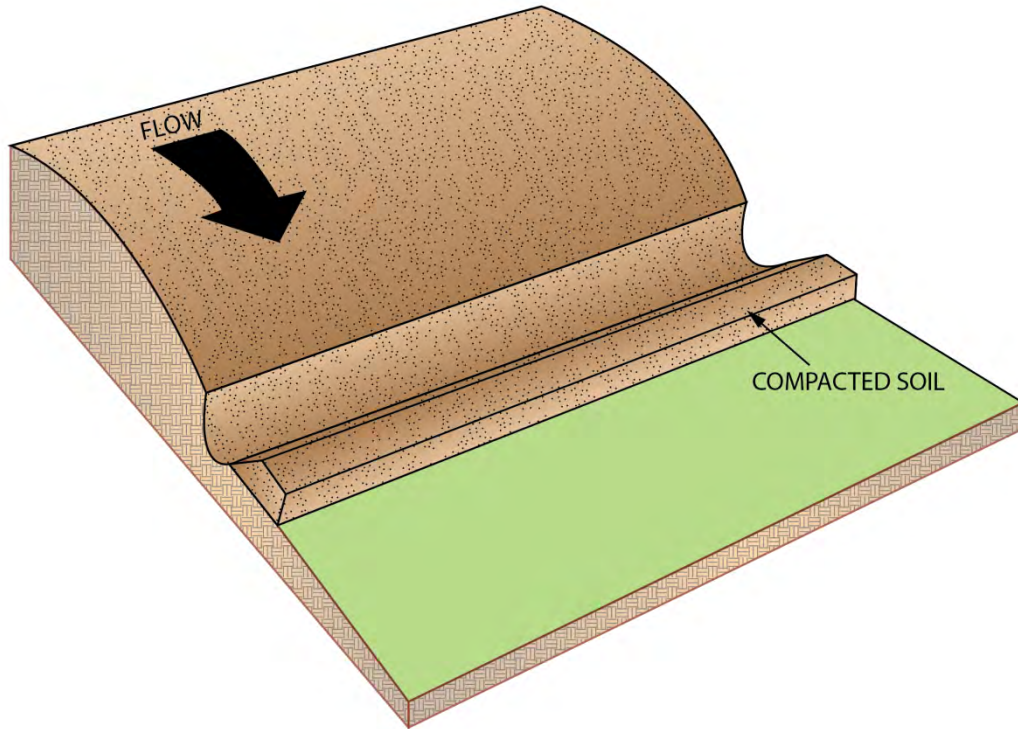

ISOMETRIC VIEW

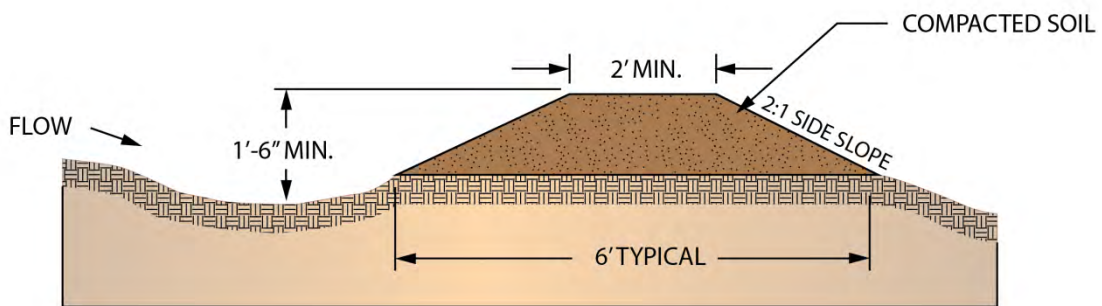

CROSS SECTION

## 4.3.2 Temporary Diversion (1630.05)



### Material Specifications

- The temporary diversion and berm shall be considered unclassified earth material and stabilized with seed, fertilizer and mulch or other approved stabilization techniques.

### Construction Specifications

Berm	<ul style="list-style-type: none"> <li>Bottom of excavation to top of berm should be 1.5-foot minimum depth</li> <li>Berm should be 2-foot minimum width at the top, and 6 feet at the bottom</li> <li>Berm created by the excavated material placed on the downslope side of the ditch should be stabilized in accordance with Sections 1620 and 1660 of the Standard Specifications</li> </ul>
Side Slopes	<ul style="list-style-type: none"> <li>Side slopes should be 2:1 or of sufficient angle to allow vegetative growth to prevent erosion.</li> </ul>

### Technician's Checklist

- Devices should be inspected regularly and after significant rainfall
- Sediment should be removed when the temporary diversion is 50 percent of the design depth
- Immediate repairs should be performed if any damage is identified within the diversion
- Stabilization within the diversion should be maintained to prevent erosion

**Temporary diversions control water flow patterns.**

### Measurement & Payment

When silt is removed from Temporary Diversion, it is paid for as "Silt Excavation." There is no additional pay for other maintenance or removing the device.

Pay Items	Pay Units
Seed for Temporary Seeding	Pound
Fertilizer for Temporary Seeding	Ton
Seeding and Mulching	Acre
Silt Excavation	Cubic Yard

## 4.3.2 Temporary Diversion (1630.05)



### Maintenance

It is important that the temporary diversion be maintained to prevent erosion and sedimentation from occurring.

- Devices should be inspected on regular basis and after each significant rainfall
- At a minimum, sediment should be removed from the channel when the temporary diversion is 50 percent of the design depth
- Temporary diversions should be immediately repaired if damaged by equipment or breached by runoff

**The temporary diversion should be maintained until the stabilization of final drainage ways.**

### Typical Problems

- Significant erosion of the diversion caused by steep grade
- Accumulated sediment deposits not removed in a timely manner
- Erosion in the diversion due to vertical side slope installation
- Sediment retention device not provided down gradient of diversion
- Improper use of a temporary diversion in areas of high water flows that are sustained for long periods
- Difficulty in accessing temporary diversions due to high adjacent fill section
- Diversion saturated by high water table
- Inadequate or no means of stockpiling silt cleanout material

## 4.3.3 Temporary Silt Ditch (1630.03)

— TSD —



### Definition

A temporary silt ditch is commonly placed at the toe of a fill slope to prevent off-site sedimentation. The silt ditch should direct sheet flow to silt basins, rock sediment dams or other sediment control measures located at the outlet of the silt ditch.

### Areas of Use

Install temporary silt ditches in these locations:

- At the toe of fill slopes where the fill exceeds 3 feet in height
- Adjacent to streams to intercept flow and/or divert the flow to a controlled outlet point
- Along project perimeters to minimize sediment loss from the project site

### Design Criteria

- Drainage area shall be 10 acres or less
- Grade should be limited to prevent erosive velocities
- Capacity of the temporary silt ditch should accommodate the peak runoff from a 10-year storm
- Velocity checks (rock silt checks or wattles) should be placed within temporary silt ditches

### Practical Tips

- If space is available, silt ditches provide considerable savings over silt fences.
- Temporary silt ditches are used almost exclusively at the bottom of slopes.
- The silt ditch should **NOT** be used within jurisdictional waters or wetlands.

**Temporary silt ditches are used in conjunction with other measures to contain sediment at outlets.**

## 4.3.3 Temporary Silt Ditch (1630.03)

— TSD —

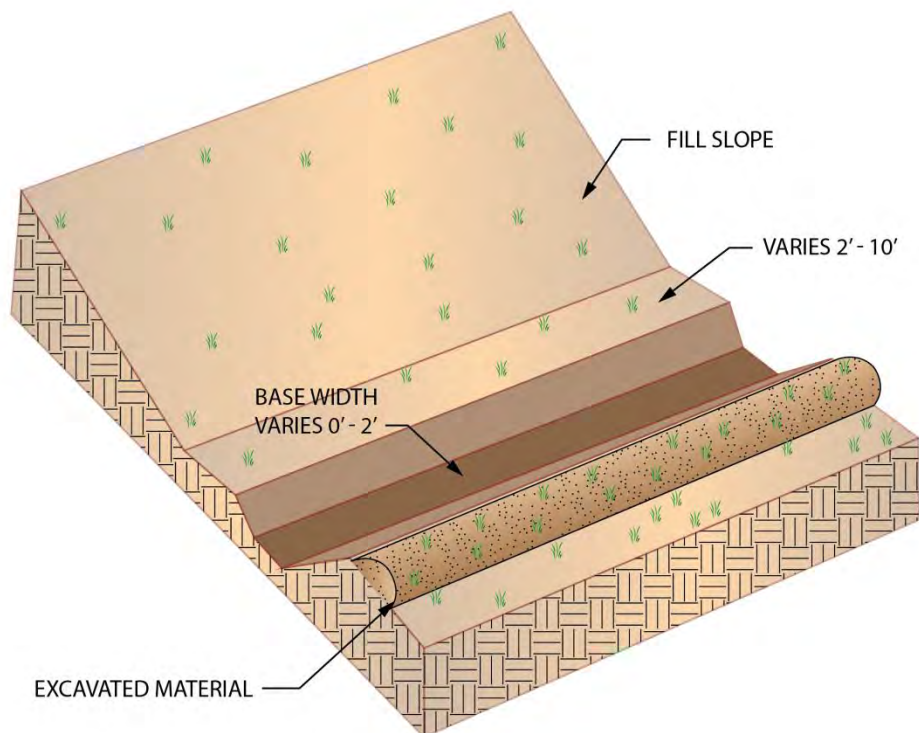

ISOMETRIC VIEW

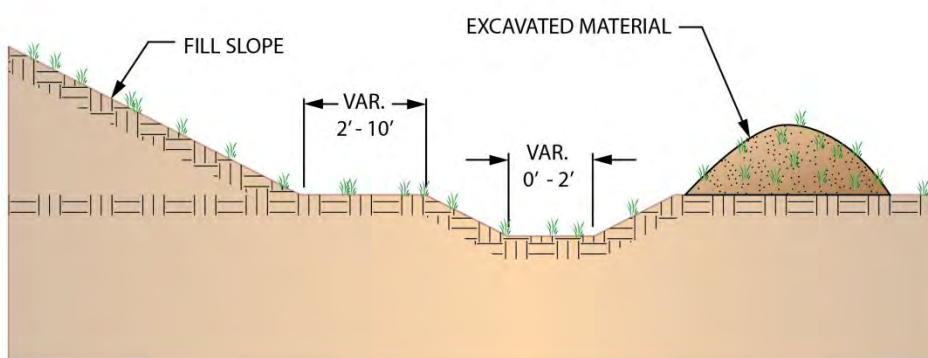

CROSS SECTION

## 4.3.3 Temporary Silt Ditch (1630.03)

— TSD —

### Material Specifications

- The temporary silt ditch and berm shall be considered unclassified earth material and stabilized with seed, fertilizer and mulch.

### Construction Specifications

Berm	<ul style="list-style-type: none"> <li>Stabilize the berm created by the excavated material placed on the downslope side of the ditch in accordance with Sections 1620 and 1660 of the Standard Specifications.</li> </ul>
Side Slopes	<ul style="list-style-type: none"> <li>Side slopes should be non-vertical and not be greater than 1.5:1 slope.</li> </ul>
Depth	<ul style="list-style-type: none"> <li>The silt ditch should be approximately 1-foot deep.</li> </ul>

The ditch outlet control measures should be installed first. The ditch should then be excavated downgradient to upgradient.

### Technician's Checklist

- Devices should be inspected regularly and after significant rainfall.
- Sediment should be removed when the temporary silt ditch is 50 percent of the design depth.
- Immediate repairs should be performed if any damage is identified within the ditch or outlet devices.
- Stabilization within the ditch should be maintained to prevent erosion.

Temporary silt ditches are usually placed at the toe of fills, around waste areas and selected locations in borrow pits.

### Measurement & Payment

When sediment is removed from temporary silt ditch, it is paid for as "Silt Excavation." There is no additional pay for other maintenance or removing the device.

Pay Items	Pay Units
Silt Excavation	Cubic Yard
Seed for Temporary Seeding	Pound
Fertilizer for Temporary Seeding	Ton
Seeding and Mulching	Acre

## 4.3.3 Temporary Silt Ditch (1630.03)

— TSD —

### Maintenance

Maintenance of temporary silt ditches is essential because water flow may become concentrated. Any breakthrough can cause more erosion and potential sediment loss than if the silt ditch was never installed.

- Devices should be inspected on a regular basis and after each significant rainfall.
- At a minimum, sediment should be removed from the channel when it accumulates to 50 percent of the design depth.
- Temporary silt ditches should be immediately repaired if damaged by equipment, breached by runoff or covered by fill.
- Sediment control devices should be inspected at the outlet of the silt ditch and cleaned out and repaired as necessary.
- Ditches should be backfilled and stabilized prior to the completion of the project.

**Temporary silt ditches can be used in the place of silt fence when space is available and when critical resources are not located near the project perimeter.**

### Typical Problems

- Excessive sediment accumulations in the ditch
- Erosion in the ditch due to vertical side slope installation
- Difficulty in accessing temporary silt ditches due to high adjacent fill section
- Lack of maintenance for devices at the outlet of the ditch, allowing sediment to escape
- Accumulated sediment deposits not removed in a timely manner
- Inadequate or no means of stockpiling silt cleanout material

## 4.3.4 Silt Fence Breaks



### Practical Tips

- Silt fence breaks should be used within clearing and grubbing and final grade phases of E&SC plans.
- Silt fence breaks should be installed with a maximum spacing of 200 feet.

### Definition

Silt fence breaks are sediment control measures within long segments of silt fence used to intercept runoff. The break in the long silt fence section serves as a drainage break and also provides additional sediment control in low areas. There are two types of silt fence breaks: special sediment control fence (SSCF) breaks and wattle breaks. Two types of wattle breaks can be used: coir fiber wattle breaks and excelsior wattle breaks.

### Areas of Use

Use silt fence breaks in long sections of silt fence at the following locations:

- At the toe of fills in long sections of silt fence to provide a drainage break or turnout
- In low areas in conjunction with silt fence
- In areas where concentrated flow exceeds the limits of temporary silt fence
- In wetland areas wattle breaks are preferred because removal is easier and provides minimal disturbance
- In areas near flowing water, SSCF breaks permit tides and surges to cross the silt fence without compromising it

**Silt fence breaks are used in locations where silt fence could become inundated with flow during storm events.**

## 4.3.4 Silt Fence Breaks



### Design Criteria

#### SSCF Breaks

- Do not exceed ½ acre drainage area
- Install a minimum of every 200 feet along silt fence
- Limit SSCF breaks to 15-foot sections when used as turnouts for silt fence in wetlands to facilitate removal of stone and minimize disturbance

**Unless there is a sediment control measure to settle sediment before it leaves the right-of-way, flocculant should not be applied to wattle breaks.**

#### Wattle Breaks

- Install a minimum 12-inch diameter wattle at wattle break locations
- Install a minimum of every 200 feet along silt fence
- Should be 10 feet in length.
- Have a design life for 1 year (excelsior wattles). Coir fiber wattles may be used longer.

## 4.3.4 Silt Fence Breaks

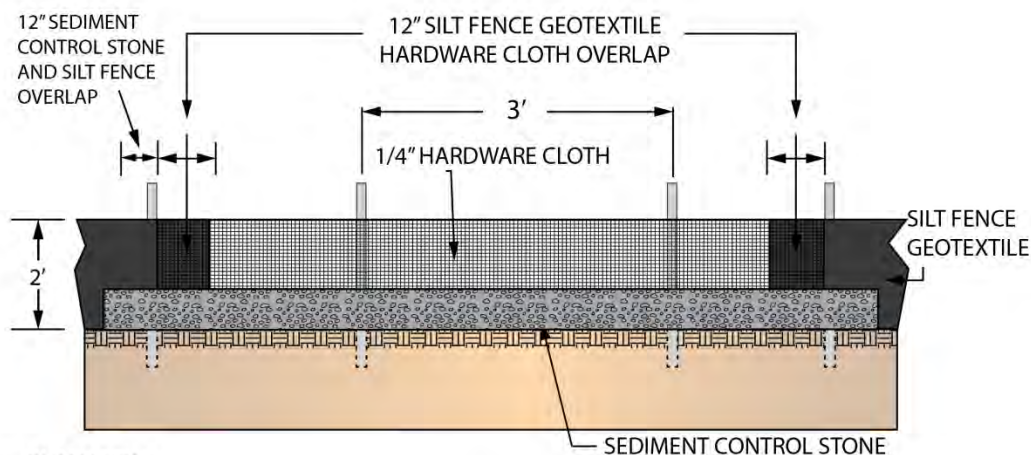

PLAN VIEW

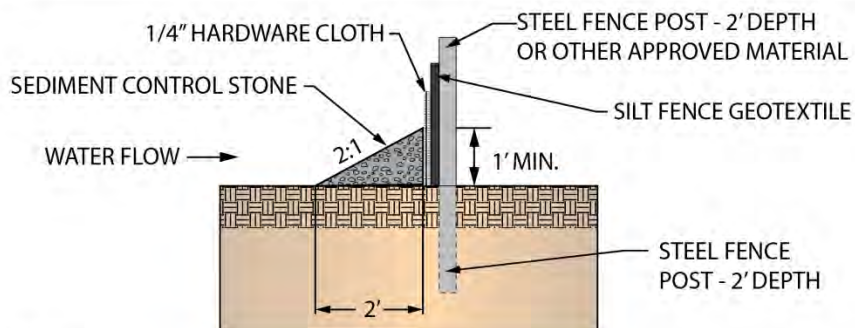

CROSS SECTION

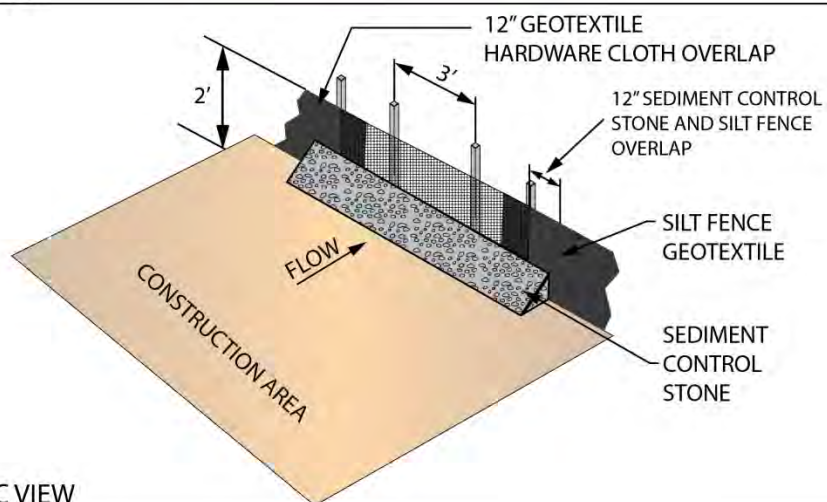

ISOMETRIC VIEW

## 4.3.4 Silt Fence Breaks

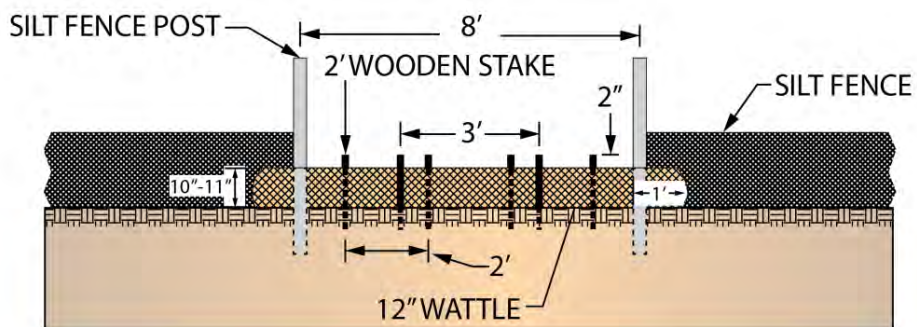

FRONT VIEW

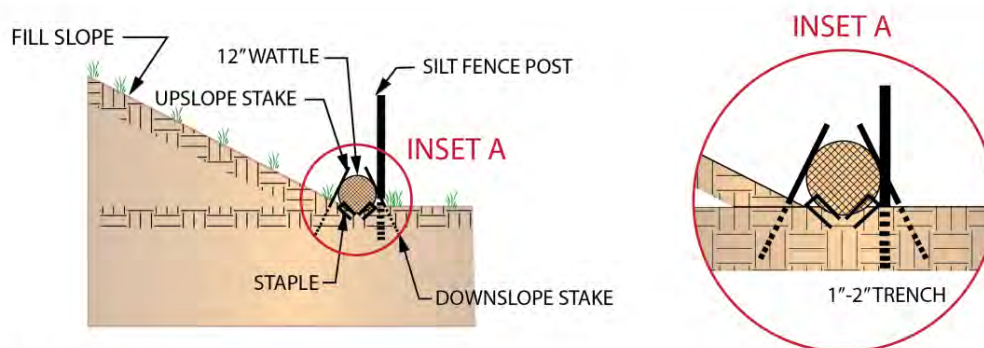

CROSS SECTION

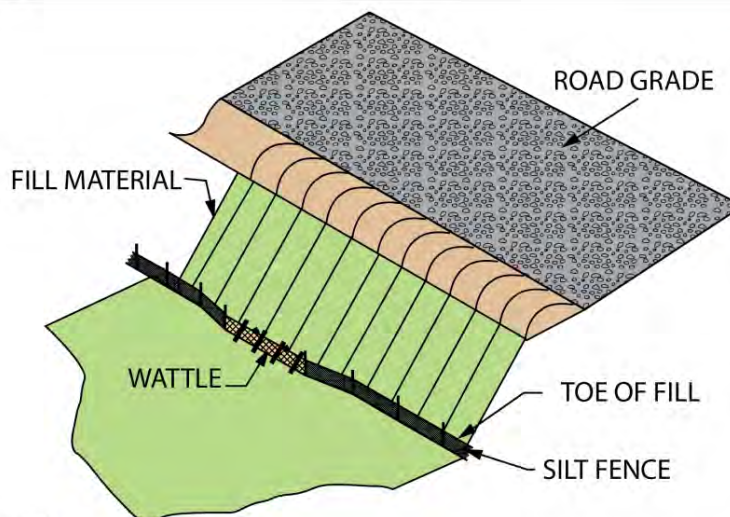

ISOMETRIC VIEW

## 4.3.4 Silt Fence Breaks



### Material Specifications

#### SSCF Breaks

Hardware Cloth	<ul style="list-style-type: none"> <li>• Hardware cloth with ¼-inch openings</li> <li>• Minimum 24-gauge wire</li> <li>• Minimum width of 48 inches</li> <li>• Meet requirements of Section 1606-2(B) of the Standard Specifications</li> </ul>
Steel Posts	<ul style="list-style-type: none"> <li>• Steel or other approved material</li> <li>• Minimum of 5-feet long</li> <li>• 1 ⅜ inches-wide on the face parallel to the hardware cloth</li> <li>• Self-fastener angle steel type</li> <li>• Meet Section 1605-2(A) of the Standard Specifications</li> </ul>
Staples	<ul style="list-style-type: none"> <li>• No. 9 wire staples with at least 1 ½-inches length or other approved attachment device</li> </ul>
Sediment Control Stone	<ul style="list-style-type: none"> <li>• No. 5 or No. 57 stone</li> <li>• Meets the requirements of Section 1005 of the Standard Specifications for stone sizes</li> </ul>

#### Wattle Breaks

Stakes	<ul style="list-style-type: none"> <li>• Wooden</li> <li>• 2-foot stakes with a 2-inch by 2-inch nominal cross section</li> <li>• Sharpened or beveled on one end</li> </ul>
Staples	<ul style="list-style-type: none"> <li>• 0.125-inch diameter steel wire</li> <li>• “U”-shape</li> <li>• 12 inches in length (at minimum) and 1-inch width</li> <li>• Meet Section 1605-2 of the Standard Specifications</li> </ul>

#### Coir Fiber Wattle Break

Inner Material	<ul style="list-style-type: none"> <li>• Coconut fibers</li> </ul>
Dimensions	<ul style="list-style-type: none"> <li>• Minimum diameter of 12 inches and a maximum of 20 inches</li> <li>• Length of 10 feet</li> <li>• Density of 3.5 lb/ft<sup>3</sup></li> </ul>

## 4.3.4 Silt Fence Breaks



### Excelsior Wattle Break

<b>Inner Material</b>	<ul style="list-style-type: none"> <li>• Curled wood</li> </ul>
<b>Dimensions</b>	<ul style="list-style-type: none"> <li>• Minimum diameter of 12 inches and a maximum of 20 inches</li> <li>• Length of 10 feet</li> <li>• Density of 2.5 lb/ft<sup>3</sup></li> </ul>

## Construction Specifications

### SSCF Breaks

Work includes furnishing materials, installation of coir fiber wattles and removing wattles. Installation of the SSCF breaks shall follow the detail provided in the plans and as directed.

<b>Sediment Control Stone</b>	<ul style="list-style-type: none"> <li>• Install on the upgradient face of the hardware cloth to a height of 1 foot</li> </ul>
<b>Steel Posts</b>	<ul style="list-style-type: none"> <li>• Install a minimum of 2-feet deep and a maximum spacing of 3 feet</li> </ul>
<b>Hardware Cloth</b>	<ul style="list-style-type: none"> <li>• Install at a height of 2 feet and placed 2-feet under the sediment control stone</li> <li>• Install top of the hardware cloth a minimum of 1-foot below the shoulder to prevent flow from entering the roadway</li> <li>• Install top of hardware cloth a minimum of 1-foot below any clean water diversion</li> <li>• Attach to posts with wire staple or other approved method</li> </ul>
<b>Overlap and Spacing</b>	<ul style="list-style-type: none"> <li>• Overlap silt fence 12 inches on either side</li> <li>• In wetland areas, limit SSCF sections to 15-foot sections spaced a maximum of 200 feet apart</li> </ul>

## 4.3.4 Silt Fence Breaks



### Wattle Breaks

Work includes furnishing materials, installation of coir fiber wattles and removing wattles. Installation of wattle breaks shall follow the detail provided in the plans and as directed.

<b>Matting</b>	<ul style="list-style-type: none"> <li>Install matting in accordance with Section 1631 of the Standard Specifications</li> </ul>
<b>Staples</b>	<ul style="list-style-type: none"> <li>Install staples approximately every 1 foot on both sides of the wattle and at each end to secure it to the soil</li> </ul>
<b>Stakes</b>	<ul style="list-style-type: none"> <li>Install a minimum of 2 upslope stakes and 4 downslope stakes at an angle to wedge wattle to bottom of ditch</li> <li>Install with a maximum spacing of 3 feet for upslope and 2 feet for downslope</li> <li>Drive stakes into the ground a minimum of 10 inches with no more than 2 inches projecting from the top of the wattle</li> </ul>
<b>Overlap</b>	<ul style="list-style-type: none"> <li>Overlap wattle and silt fence geotextile a minimum of 1 foot. Silt fence geotextile should have an opening of 8 feet.</li> </ul>
<b>Trench</b>	<ul style="list-style-type: none"> <li>Install a trench with a depth of 1 to 2 inches for the length of the wattle</li> </ul>

Wattles can be installed on the downgradient side of the temporary silt fence as directed. Temporary silt fence should be installed in accordance with Section 1605 of the Standard Specifications.

### Technician's Checklist

#### SSCF Breaks

- Check the environmental permits to verify that the fence is placed in the proper location and in accordance with the permit drawings and provisions. Fence materials shall meet the requirements of Section 1606.
- Install the fence in advance of the need to contain sediment.
- Make any necessary additions or adjustments to the SSCF based on field conditions.
- Install materials according to the plan details (see Roadway Standard Drawing No. 1606.01).
- Remove silt accumulation when silt reaches half the height of the stone and dispose of waste properly.
- Measure the silt removed for payment.
- Remove fence, posts and stone when the permanent controls have been established. Do not leave the stone on site and do not place any stone in permitted areas.

**Prior to installing the SSCF break, check permitted areas. Stone installation is considered temporary fill and permit conditions must allow its use.**

## 4.3.4 Silt Fence Breaks



### Wattle Breaks

- Devices should be inspected regularly and after significant rainfall.
- Sediment, debris, straw and other items should be removed from the wattle.
- Verify proper installation of anchors to secure wattles to the ground.

### Measurement & Payment

Silt fence breaks will be measured and paid for by the number of linear feet of ¼-inch hardware cloth and tons of sediment control stone or by the number of linear feet of wattles which are installed and accepted. Such price and payment will be full compensation for all work covered by this section, including furnishing all materials, labor, equipment and incidentals necessary to install, maintain and remove the silt fence breaks, except for the removal of silt from special sediment control fence breaks.

#### SSCF Break

Pay Items	Pay Units
¼-inch Hardware Cloth	Linear Foot
Sediment Control Stone	Ton
Silt Excavation	Cubic Yard

#### Coir Fiber Wattle Break

Pay Items	Pay Units
Coir Fiber Wattle	Linear Foot

#### Excelsior Wattle Break

Pay Items	Pay Units
Wattle	Linear Foot

## 4.3.4 Silt Fence Breaks



### Maintenance

It is important for the silt fence breaks to be maintained until final inspection of the project or until the silt fence breaks are removed. Upon removal, the Contractor should remove and dispose of all silt accumulations in accordance with Section 1630 of the Standard Specifications.

### SSCF Break

- Inspect the device periodically and after each significant rainfall event for damage and sediment accumulation to confirm the device is functioning properly.
- At a minimum, remove sediment from the device when accumulations reach one-half the height of the sediment control stone.
- Replace or clean the sediment control stone as needed to allow water to drain through the device between rainfall events.
- Rebuild and/or repair the device when it is damaged.
- Repair areas where SSCF becomes undermined due to concentrated flows.

**Wattle breaks are easier to remove than SSCF breaks.**

### Wattle Break

It is important that wattle breaks be kept clean and allow water to flow through the natural fibers. The wattle breaks can become blocked with debris, sediment, straw and other items.

- If the natural fibers of the wattle become too saturated with debris and sediment and removal of the items is not possible, wattle breaks should be replaced.
- Stakes should be used to anchor the wattle breaks adequately to the ground to prevent scouring and washout during storm events.

## 4.3.4 Silt Fence Breaks



### Typical Problems

- The silt fence breaks are not overlapped properly to the temporary silt fence.
- The hardware cloth is not adequately buried to prevent undermining.
- Sediment accumulations are not removed in a timely fashion, causing sediment to be released offsite.
- The silt fence break is not rebuilt or repaired when damaged by storms, equipment, etc.

### SSCF Break

- Sediment control stone is not cleaned and becomes clogged, preventing proper drainage.
- Runoff becomes concentrated in areas and undermines the hardware cloth and sediment control stone.

### Wattle Break

- Improper installation and failure to properly anchor the break to the ground reduces the effectiveness of the measure to control erosion and reduce velocities.

## 4.3.5 Temporary Earth Berm



### Practical Tips

- Place earth berms inside footprint of fill slopes to divert runoff to sediment basins.
- Place velocity checks (either a Temporary Rock Silt Check or wattle) with earth berms.

### Definition

A temporary earth berm is a compacted earthen dike used along the site perimeter for either off-site flow diversion or sediment storage at the toe of a fill slope. Earth berms direct water to specific sediment control devices or direct water flowing from offsite away from or around areas of construction.

### Areas of Use *(italicized text was excerpted from NCDENR, 2013)*

- Along fill slopes, generally parallel to the right-of-way
- *Below slopes to divert excess runoff to stabilized outlets*
- *Where needed to divert sediment-laden water to sediment basins or traps*
- *At or near the perimeter of the construction area to keep sediment from leaving the site (NCDENR, 2013)*

### Design Criteria

- Utilize on Clearing & Grubbing and Final Grade Phases of E&SC plans
- Consider how construction machinery will access the location to remove the berm without damaging completed and stabilized slope areas

## 4.3.5 Temporary Earth Berm

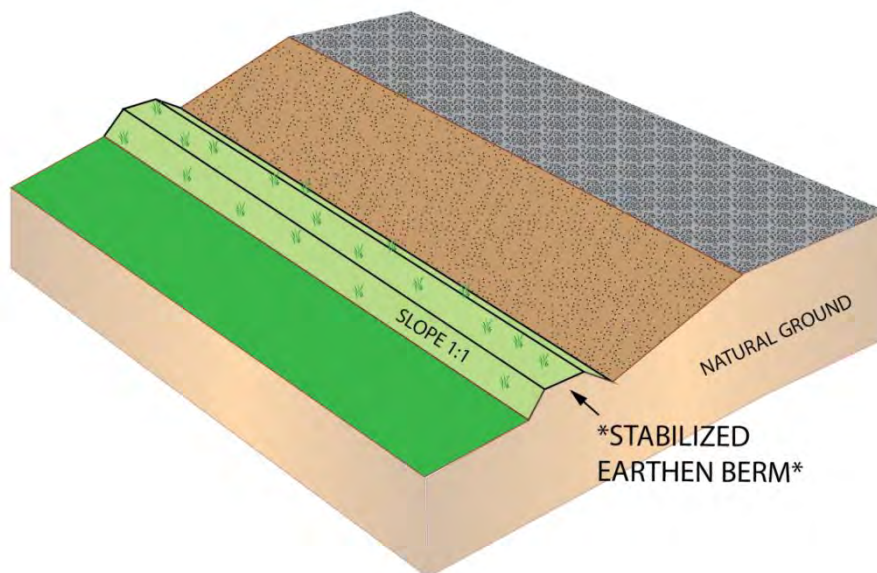

ISOMETRIC VIEW (NOT TO SCALE)

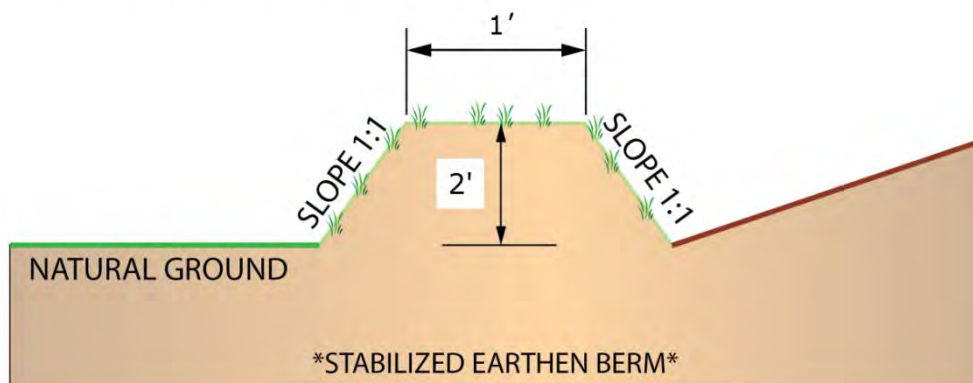

CROSS SECTION (NOT TO SCALE)

## 4.3.5 Temporary Earth Berm



### Construction Specifications (italicized text was excerpted from NCDENR, 2013)

Installation	<ul style="list-style-type: none"> <li>• Install the temporary earth berms in accordance with the details in the plans and at locations indicated in the plans, and as directed by the Engineer.</li> <li>• <i>Remove and properly dispose of all trees, brush, stumps, and other objectionable material.</i></li> <li>• <i>Compact the berm by tracking with construction equipment.</i></li> <li>• <i>Do not place the top of the berm lower at any point than the design elevation after it has been compacted.</i></li> <li>• Earth berm side slopes should be constructed with 1:1 side slopes, compacted well and immediately stabilized.</li> </ul>
Stabilization	<ul style="list-style-type: none"> <li>• Immediately stabilize the earth berms upon installation as provided in Section 1620 of the Standard Specifications. Other stabilization methods may be utilized with prior approval from the Engineer.</li> <li>• Remove the temporary earth berms upon completion of the project. The earth material can be utilized in the filling of silt ditches and detention devices, or graded to match the existing contours and permanently seeded and mulched.</li> </ul>

### Technician's Checklist

- Inspect the temporary earth berm once a week and after every rainfall.
- Check the outlets and make timely repairs as needed to avoid gully formation.
- When the area above the temporary earth berm is permanently stabilized, remove the berm or, if applicable, blend to match existing contours.

### Measurement & Payment

The installation of temporary earth berms will be paid for as Borrow Excavation as provided in Section 230 of the Standard Specifications or included in the lump sum price for grading. Stabilization of the temporary earth berms will be paid for as Temporary Seeding as provided in Section 1620 of the Standard Specifications. Such price and payment shall be considered full compensation for all work covered by this section including all materials, construction, maintenance, and removal of the temporary earth berms.

## 4.3.5 Temporary Earth Berm



### Pay Items

### Pay Units

Borrow Excavation

Cubic Yard

Seed for Temporary Seeding

Pound

Fertilizer for Temporary Seeding

Ton

### Maintenance

- Immediately remove sediment from the flow area and repair the berm when necessary.
- Reconstruct earth berms that have weakened due to scouring.
- Repair seed and mulch the berm, as needed.

### Typical Problems

- The berm is not compacted appropriately and leads to breaches
- The berm is not constructed of sufficient height to contain runoff
- The berm is not constructed with good, positive drainage, which results in ponding and potential slope failure

# 4.4

## Section

### Slope Protection

Temporary Slope Drain	4.4.1
Special Sediment Control Fence	4.4.2
Rolled Erosion Control Products	4.4.3
Wattle Barrier	4.4.4

*Also see Temporary Earth Berm in Section 4.3*

All slopes within a construction site must be identified early in the planning phase. Topographic conditions (e.g., soil type, percent grade, locations of natural channels) must be documented so that slopes can be properly protected. The longer and steeper the slope, the greater the effort needed to prevent erosion. BMPs will often need to be combined on steep slopes, long slopes and/or slopes with highly erodible soils.

When possible, implement temporary slope drains, temporary earth berms and wattle barriers to keep stormwater off of the slope. Special sediment control fencing and rolled erosion control products are effective BMPs for slope protection.

## 4.4.1 Temporary Slope Drain (1622.01)

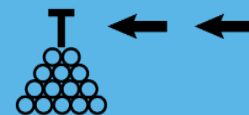

### Practical Tips

- Install early in construction
- Pay particular attention to the inlet, outlet and pipe joints.

### Definition

A temporary slope drain is a flexible tubing or pipe used to convey concentrated runoff from the top to the bottom of a cut or fill slope without causing significant erosion along the slope. An earth berm is an earthen barrier designed to channel runoff to the slope drain inlet. The temporary slope drain pipe should be long enough to extend to the bottom of the slope and directed into a prescribed sediment control device.

### Areas of Use

- Above cut or fill slopes where runoff flowing over the slope would cause erosion if left unchecked
- Not for fill or cut slopes that are 4:1 or flatter

## 4.4.1 Temporary Slope Drain (1622.01)

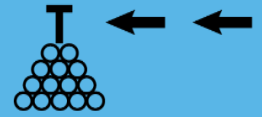

### Design Criteria

- Slope drain should have capacity to pass the peak runoff from the 10-year storm
- Projects in Divisions 1, 2, 3, and 6 should have slope drains on fill slopes 5 feet or higher and steeper than 4:1
- All other divisions should use slope drains for fill slopes that are 8 feet or higher and steeper than 4:1
- Show slope drains on both sides of fill slopes regardless of super elevation slope
- Projects in Divisions 1, 2, 3, and 6 should have slope drains on fill areas with roadbed super elevation that is greater than 0.04 feet/foot and 3 feet or higher
- All other divisions should use slope drains for fill areas with roadbed super elevation that is greater than 0.04 feet/foot and 5 feet or higher
- Unless individually designed, should size slope drains in accordance with the following:

Maximum Drainage Area Per Pipe (acres)	Pipe Diameter (inches)
0.50	12
0.75	15
1.00	18*

\*NCDOT uses a minimum pipe diameter of 18" and limits the drainage area to 1 acre for individual slope drains.  
Adapted from Table 6.32, Erosion and Sediment Control Planning and Design Manual, NCDENR

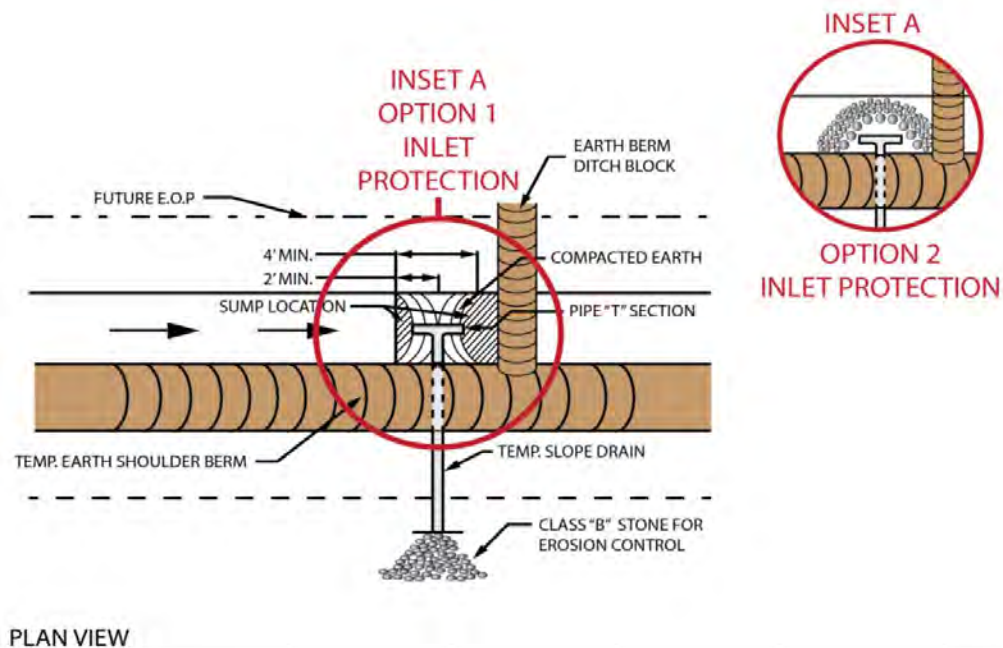

## 4.4.1 Temporary Slope Drain (1622.01)

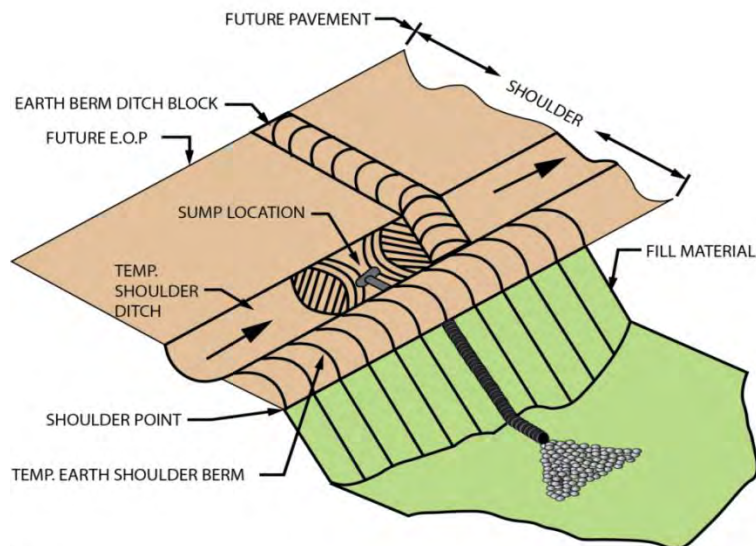
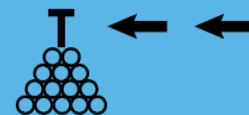

ISOMETRIC VIEW

### Material Specifications

- Construct the slope drain from heavy-duty, flexible materials such as non-perforated, corrugated plastic pipe or specially designed flexible tubing.
- Construct earth berms with on-site unclassified earth material.
- Use Class B stone that meets the requirements of Section 1042 of the Standard Specifications for Stone for Erosion Control, Class B as structural stone at the slope drain inlet.
- Use No. 5 or No. 57 stone that meets the requirements of Section 1005 of the Standard Specifications for these stone sizes as structural stone at slope drain inlet.

**If the berm is topped or breached, the water will not get to the slope drain. The grade of the ditch formed by the berm must have sufficient fall to keep the water moving toward the drain.**

## 4.4.1 Temporary Slope Drain (1622.01)

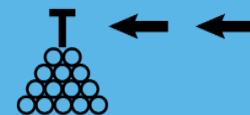

### Construction Specifications

<b>Installation</b>	<ul style="list-style-type: none"> <li>• Install slope drains in conjunction with grading and adjust to coincide with the height of the embankment as construction progresses.</li> <li>• Install stakes to anchor the conduit at intervals not to exceed 10 feet with the outlet end securely fastened in place. The conduit must extend beyond the toe of the slope.</li> <li>• Construct the slope drain so that erosion or scouring does not occur underneath or around the sides of the pipe inlet.</li> <li>• When using the earthen berm in conjunction with the slope drain, construct the lowest point of the berm ridge a minimum of 1-foot above the top of the drain so that design flow can freely enter the drain.</li> <li>• Install a standard T-section at inlets as necessary for multi-directional flow and elbows for single directional flow.</li> </ul>
<b>Stone</b>	<ul style="list-style-type: none"> <li>• Protect outlet locations subject to scour with Class B stone or a silt detention device. A special stilling basin may also be used as outlet protection. Construct outlet protection devices as shown in the plans and at other locations as directed.</li> </ul>
<b>Spacing</b>	<ul style="list-style-type: none"> <li>• Implement a maximum slope drain spacing of 200 feet measured along the top of the slope.</li> </ul>

### Technician's Checklist

- Construct inlets and outlets properly to prevent scour. (See Roadway Standard Drawing No. 1622.01.)
- Inspect the berm at least weekly to determine if overtopping is occurring. If so, additional slope drains are needed.
- Utilize drains that are long enough to reach the toe of the slope and turn the pipe in the ditch line in the direction of flow.
- If a basin is planned at the toe of the fill, review the permits to determine if it is allowed.
- Stake the pipe at 10-foot horizontal intervals.
- Place the drains at the low point and no more than 200 feet apart.
- Keep the inlet clear so that water does not bypass the drain.
- Keep the outlet clear.
- As the pipe is extended, confirm that standards for staking and inlet/outlet protection are met.
- When the drain is removed, dress and seed the area.

## 4.4.1 Temporary Slope Drain (1622.01)

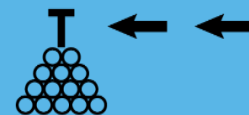

### Measurement & Payment

#### Pay Items

Temporary Slope Drains

#### Pay Units

Linear Foot

### Maintenance

- Inspect slope drains after each significant rainfall of 0.5 inches or greater, over a 24-hour period.
- Rebuild earth berms and inlets that have weakened due to scouring.
- Extend slope drains and rebuild inlet protection as slope is built, after each 2-foot increase in height.
- Rebuild or repair slope drains if needed when seeding and mulching is performed.
- Refurbish Class B stone outlet protection and clean as needed.

### Typical Problems

- Slope drains that empty off-site without passing water through a specified sediment control device such as a silt basin, sediment dam, etc.
- Washes under and around inlet pipe where earth material is not compacted properly
- Pipe is too short and scours bottom of slope
- Pipe is leaking at joints or not properly connected
- Outlet ends of pipe are clogged or inundated with silt so that flow cannot continue
- Silt basins, built at top of slope drain, can contribute to problems of scouring around inlet
- Shifting of slope drain due to improper staking or the absence of staking

## 4.4.2 Special Sediment Control Fence (1606.01)



### Definition

Special sediment control fence (SSCF) is hardware cloth faced with sediment control stone. Runoff velocity is reduced allowing soil particles to settle. It may also temporarily pond the runoff, helping to settle or trap sediment before the water passes through the stone. SSCF also allows areas of diffuse flow to be maintained.

### Areas of Use

- In areas where excavated basins are not feasible
- Between toe of fill slopes and stream relocations where excavated basins are not feasible
- In areas where concentrated flow would exceed limits of temporary silt fence
- With temporary silt fence in wetland areas
- Not where flow will run parallel to the stone and not allow ponding of runoff

### Design Criteria

- The drainage area should not exceed ½ acre to a section of SSCF.
- SSCF may be used as outlets for silt fence at a minimum of every 200 feet to prevent overflow and alleviate force created by runoff.
- SSCF should be limited to 15-foot sections when used as turnouts for silt fence in wetlands to facilitate removal of stone and minimize disturbance.

### Practical Tips

- SSCF is generally used in conjunction with silt fence to provide outlets for water that can be trapped by silt fence.
- SSCF is useful in areas near flowing water to permit tides and surges to cross the fence without compromising it.

## 4.4.2 Special Sediment Control Fence (1606.01)

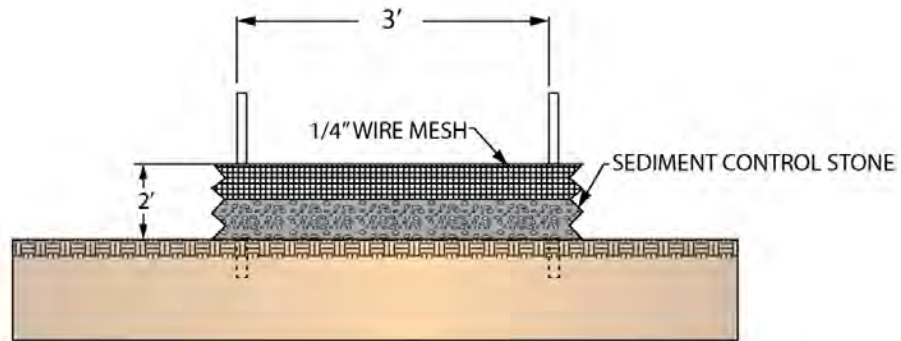

FRONT VIEW

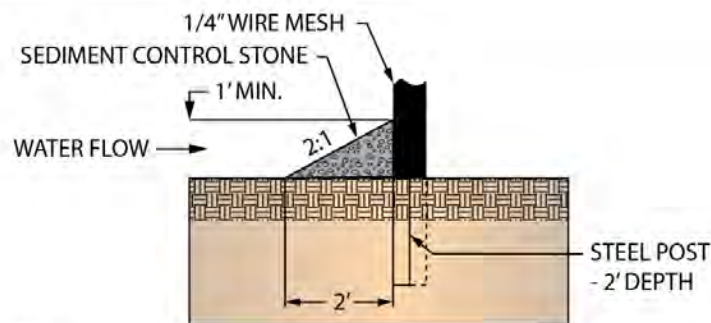

CROSS SECTION

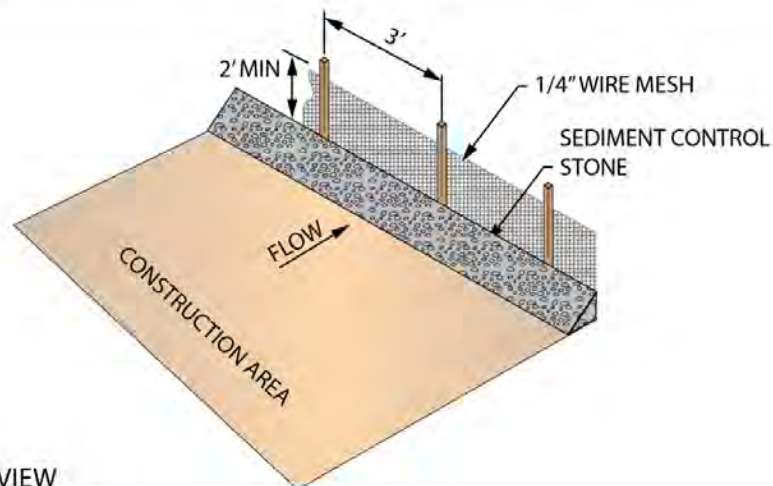

ISOMETRIC VIEW

## 4.4.2 Special Sediment Control Fence (1606.01)



### Material Specifications

- Hardware cloth shall be a wire mesh with ¼-inch openings and constructed from minimum 24-gauge wire that is at least 48 inches in width, as required in Section 1606-2 of the Standard Specifications.
- Steel posts shall be a minimum of 5-feet long, 1-3/8 inches wide on the face parallel to the hardware cloth, and be of the self-fastener angle steel type. See Section 1606-2 of the Standard Specifications.
- Sediment control stone shall be No. 5 or No. 57 stone that meets the requirements of Section 1005 of the Standard Specifications for these stone sizes.

**All posts may appear similar however it is imperative that a properly sized post is utilized to reduce the likelihood that the fence will bend from pressure.**

### Construction Specifications

<b>Hardware Cloth</b>	<ul style="list-style-type: none"> <li>• The hardware cloth shall be installed at a height of 2 feet and placed 2-feet under the sediment control stone.</li> <li>• Sediment control stone shall be installed on the outer face of the hardware cloth to a height of 1 foot.</li> <li>• The top of the hardware cloth shall be a minimum of 1-foot below the shoulder to prevent flow from backing up into the roadway.</li> <li>• The top of the hardware cloth shall also be a minimum of 1-foot below any clean water diversion to prevent runoff from backing up, mixing with clean water and bypassing the SSCF through the clean water diversion.</li> </ul>
<b>Steel Posts</b>	<ul style="list-style-type: none"> <li>• The steel posts shall be installed a minimum of 2-feet deep and with a maximum spacing of 3 feet.</li> </ul>
<b>Silt Fence</b>	<ul style="list-style-type: none"> <li>• SSCF sections used with silt fence in wetland areas shall be limited to 15-foot sections spaced a maximum of 200 feet apart to allow for complete removal of sediment control stone and to minimize impacts to wetlands.</li> <li>• When SSCF is used in conjunction with silt fence, sediment control stone should extend (overlap silt fence) 12 inches on either side</li> </ul>

## 4.4.2 Special Sediment Control Fence (1606.01)



### Technician's Checklist

- Check the environmental permits to verify that the fence is placed in the proper location and in accordance with the permit drawings and provisions. Fence materials shall meet the requirements of Section 1606.
- Install the fence in advance of the need to contain sediment.
- Make any necessary additions or adjustments to SSCF based on field conditions.
- Install materials according to plan details. (See Roadway Standard Drawing No. 1606.01.)
- Remove silt accumulation when silt reaches half the height of the stone and dispose of waste properly.
- Measure the silt removed for payment.
- Remove fence, posts and stone when the permanent controls have been established. Do not leave the stone on site and do not place any stone in permitted areas.

### Measurement & Payment

#### Pay Items

#### Pay Units

¼-inch Hardware Cloth

Linear Foot

Sediment Control Stone

Ton

Silt Excavation

Cubic Yard

### Maintenance

- Inspect the device periodically and after each significant rainfall event for damage and sediment accumulation to confirm the device is functioning properly.
- At a minimum, remove sediment from the device when accumulations reach one-half the height of the sediment control stone.
- Replace or clean the sediment control stone as needed to allow water to drain through the device between rainfall events.
- Rebuild and/or repair the device when it is damaged.
- Repair areas where SSCF becomes undermined due to concentrated flows.

### Typical Problems

- Sediment accumulations are not removed in a timely fashion, causing sediment to be released offsite.
- The sediment control stone is not cleaned and becomes clogged, preventing proper drainage.
- The device is not rebuilt or repaired when damaged by storms, equipment, etc.
- The device is not built wide enough to prevent water from washing around it. Water should always flow through or over the device, not around.
- Runoff becomes concentrated in areas and undermines the hardware cloth and sediment control stone.

## 4.4.3 Rolled Erosion Control Products (RECP) (1631.01)



### Practical Tips

- Proper trenching, anchoring and stapling are critical for matting to function properly.

### Definition

Matting is a type of rolled erosion control product (RECP) designed to reduce seed and soil loss and to aid in the reestablishment of vegetation on highly erodible surfaces such as steep slopes and channels, or areas where vegetation may be difficult to establish.

### Areas of Use

- Coir Fiber Matting should be used for stream banks and flood plain areas.
- Temporary Erosion Control Matting (Excelsior) can be used on most slopes and ditches.
- Permanent Soil Reinforcement Matting (PSRM) or Turf Reinforcement Matting shall be used on ditches with steep grades (4% to 5%).

### Design Criteria

- Provide a smooth soil surface free from stones, clods or debris that will optimize contact of the matting with the soil. Matting should lie in direct contact with the soil surface. Care should be taken to avoid over compaction of soil within area of seedbed preparation.

## 4.4.3 Rolled Erosion Control Products (RECP) (1631.01)

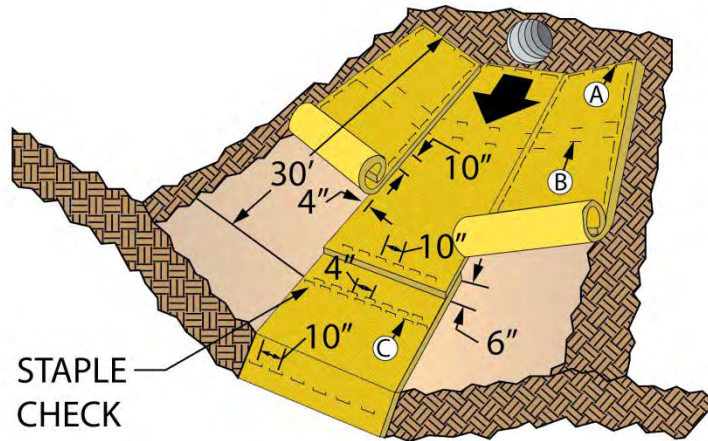

ISOMETRIC VIEW - MATTING IN DITCHES (NOT TO SCALE)

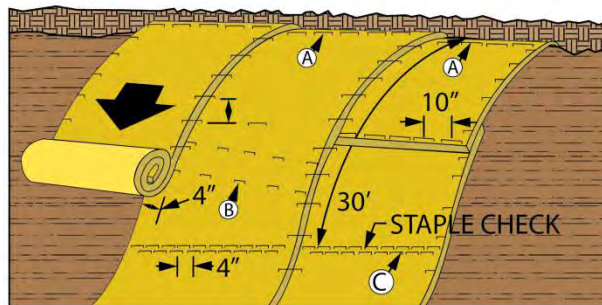

ISOMETRIC VIEW - MATTING ON SLOPES

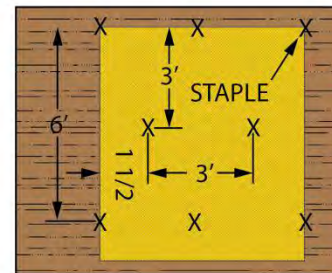

DIAGRAM REFERENCE B

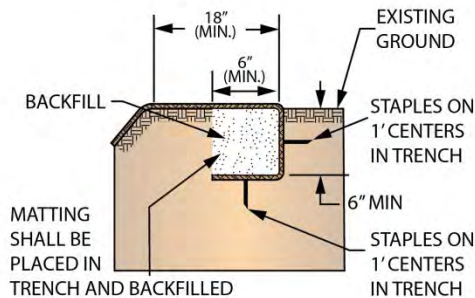

DIAGRAM REFERENCE A

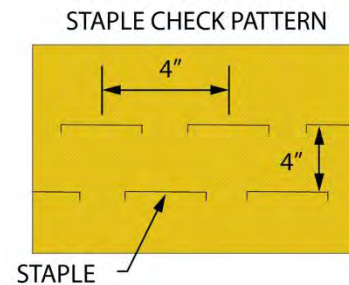

DIAGRAM REFERENCE C

## 4.4.3 Rolled Erosion Control Products (RECP) (1631.01)

### Material Specifications

Matting for erosion control shall be excelsior matting or straw matting. Furnish a Type 3 material certification in accordance with NCDOT's 2012 Standard Specifications, Article 106-3, *Contractor Furnished Certification*, certifying that the matting meets this article. Other acceptable material manufactured especially for erosion control may be used when approved by the Engineer in writing before installation. Matting for erosion control shall not be dyed, bleached or otherwise treated in a manner that will result in toxicity to vegetation.

Specific material requirements for all matting types are listed below:

#### Excelsior Matting

- Excelsior Matting shall meet the requirements of NCDOT's Standard Specifications Materials Section 1631.01.
- Excelsior Matting shall consist of a machine produced mat of curled wood Excelsior at least 47 inches in width and weigh 0.975 lb/sy with a tolerance of  $\pm 10\%$ .
- At least 80% of the individual Excelsior fibers shall be 6 inches or more in length. Excelsior fibers shall be evenly distributed over the entire area of the blanket.
- One side of the excelsior matting shall be covered with an extruded plastic mesh (netting). The mesh size shall be no more than 1 inch x 1 inch.

#### Straw Matting

- Straw Matting shall meet the requirements of NCDOT's Standard Specifications Materials Section 1631.01.
- Straw Matting shall consist of a machine produced mat of 100% grain straw.
- The straw matting shall have a width of at least 48 inches and no more than 90 inches and weigh at least 0.50 lb/sy and no more than 0.75 lb/sy.
- The straw shall be evenly distributed over the entire area of the blanket. One side of the blanket shall be covered with photodegradable netting with a maximum mesh (netting) size of 0.75 inches x 0.75 inches sewn together with a degradable thread.
- The grain straw shall contain no weed seeds.
- Each roll shall be packaged separately.

**Most RECPs are either biodegradable or photodegradable and will decompose over time, reducing the need for ongoing maintenance.**

#### Permanent Soil Reinforcement Matting

- The product shall be a permanent erosion control reinforcement mat and shall be constructed of synthetic or a combination of coir and synthetic fibers evenly distributed throughout the mat between a bottom ultraviolet (UV) stabilized netting and a heavy duty UV stabilized top net.

## 4.4.3 Rolled Erosion Control Products (RECP) (1631.01)

- The matting shall be stitched together with UV stabilized polypropylene thread to form a permanent three-dimensional structure.
- The mat shall have the following minimum physical properties. Refer to NCDOT Project Special Provisions for additional guidance.

PSRM Property	Test Method	Value	Unit
Light Penetration	ASTM D6567	9	%
Thickness	ASTM D6525	0.40	in
Mass Per Unit Area	ASTM D6566	0.55	lb/sy
Tensile Strength	ASTM D6818	385	lb/ft
Elongation (Maximum)	ASTM D6818	49	%
Resiliency	ASTM D1777	>70	%
UV Stability *	ASTM D4355	>80	%
Porosity (Permanent Net)	ECTC Guidelines	>85	%
Maximum Permissible Shear Stress (Vegetated)	Performance Bench Test	>8.0	lb/ft <sup>2</sup>
Maximum Allowable Velocity (Vegetated)	Performance Bench Test	>16.0	ft/s

\* ASTM D1682 Tensile Strength and % strength retention of material after 1000 hours of exposure.

Submit a certification (Type 1, 2, or 3) from the manufacturer showing:

- The chemical and physical properties of the mat used, and
- Conformance of the mat with these specifications.

### Wire Staples

- Staples shall be machine made of No. 11 gauge new steel wire formed into a U-shape.
- The size when formed shall not be less than 6 inches in length with a throat of not less than 1 inch in width.

## 4.4.3 Rolled Erosion Control Products (RECP) (1631.01)

### Construction Specifications

<b>Matting</b>	<ul style="list-style-type: none"> <li>• Furnish, place and maintain the appropriate type of matting on previously shaped and seeded drainage ditches, slopes or other locations shown in the contract documents, or as directed.</li> <li>• Place matting immediately following seeding.</li> <li>• Preserve the required line, grade and cross section of the area covered.</li> <li>• Unroll matting in the direction of the flow of water and apply without stretching so that it will lie smoothly but loosely on the soil surface.</li> <li>• Where one roll of matting ends and a second-roll begins, overlap the end of the upper roll over the end of the second roll so there is a 6-inch overlap.</li> </ul>
<b>Staples</b>	<ul style="list-style-type: none"> <li>• Bury the up-channel or top of slope end of each piece of matting in a trench at least 6-inches deep and 6-inches wide, staple per detail, backfill and tamp firmly.</li> <li>• Construct staple checks 4 inches on center and every 30 feet longitudinally in the matting or as directed. Fold over and bury matting to the full depth of the trench, close and tamp firmly. Overlap matting at least 4 inches where 2 or more widths of matting are laid side by side.</li> <li>• Place staples across matting at ends and junctions approximately 10 inches apart.</li> <li>• Place staples along the outer edges and down the center of each strip of matting 3 feet apart.</li> <li>• Place staples along all lapped edges 10 inches apart.</li> <li>• Install product with netting on the top side when excelsior or straw matting is used.</li> </ul>

## 4.4.3 Rolled Erosion Control Products (RECP) (1631.01)

### Technician’s Checklist

- Inspect weekly and after every storm event that results in a discharge from the site until adequate vegetation is established.
- Conduct seeding first, then immediately apply matting.
- Evenly grade all areas of application to allow for full contact between the matting and natural ground.
- Immediately repair and reseed undermined areas requiring maintenance from rill or gully erosion.
- Provide adequate trenching of up gradient edges and overlap of down gradient edges of matting.

**Matting should be placed immediately following seeding.**

### Measurement & Payment

Matting will be measured and paid for as the actual number of square yards measured along the surface of the ground over which matting is installed and accepted. Overlaps will not be included in the measurement, and will be considered as incidental to the work. Such payment shall be full compensation for furnishing and installing the mat, including overlaps, and for all required maintenance.

### Pay Items

### Pay Units

Matting For Erosion Control

Square Yard

Permanent Soil Reinforcement Mat

Square Yard

### Maintenance

- Repair erosion and/or undermining at the top of the slope.
- Repair undermining beneath matting. Pull back the matting, fill and compact eroded area, reseed and then secure matting firmly.
- Reposition or replace matting that has moved along the slope or channel and secure firmly.
- Replace damaged matting.

### Typical Problems

- It is important that the stakes or staples be properly installed to prevent “tenting” of the matting as the vegetation begins to grow and push upwards. This condition can impact vegetative establishment and the matting can become entangled in mowing equipment.
- Runoff can lift the leading edge of the matting if it is not trenched, anchored and backfilled properly at the top of the slope, allowing water to flow between the ground and the matting.

## 4.4.4 Wattle Barrier



### Definition

A wattle barrier is a tubular product consisting of excelsior or coir (coconut) fibers encased in synthetic or biodegradable netting. A wattle barrier temporarily traps sheet flow from disturbed slopes, allowing sediment to settle on the upgradient side.

### Areas of Use

Install wattles in these locations:

- Just beyond the toe of bridge approach fills or on slopes to intercept runoff
- In locations where silt fence cannot be installed
- In wetlands areas
- Where vertical clearance between the ground and the bottom of the bridge is less than 4 feet
- As a break along large slopes in order to reduce runoff velocity
- As a perimeter barrier and runoff diversion

### Practical Tips

- Flocculant can be used with wattle barriers to provide additional turbidity control.\*
  - Excelsior wattle barriers are used for short term projects.
  - Coir fiber wattle barriers are used for long term projects.
- \* -Do not apply flocculant to wattle barriers at perimeter of projects.

**Wattle barriers are used on Clearing & Grubbing and Final Grade phases of the Erosion and Sediment Control plan.**

## 4.4.4 Wattle Barrier

### Design Criteria

- 18-inch wattles should be used for wattle barriers.
- The wattle barrier should be placed in a 2- to 3-inch trench.
- A maximum spacing of 25 feet should be used for breaks along large slopes measured along the slope.
- Coir fiber wattle barriers should be used in projects lasting longer than 1 year. The design life for excelsior wattle barriers is 1 year.

**Install wattle barriers so flow will not wash around the wattle barrier and scour slopes.**

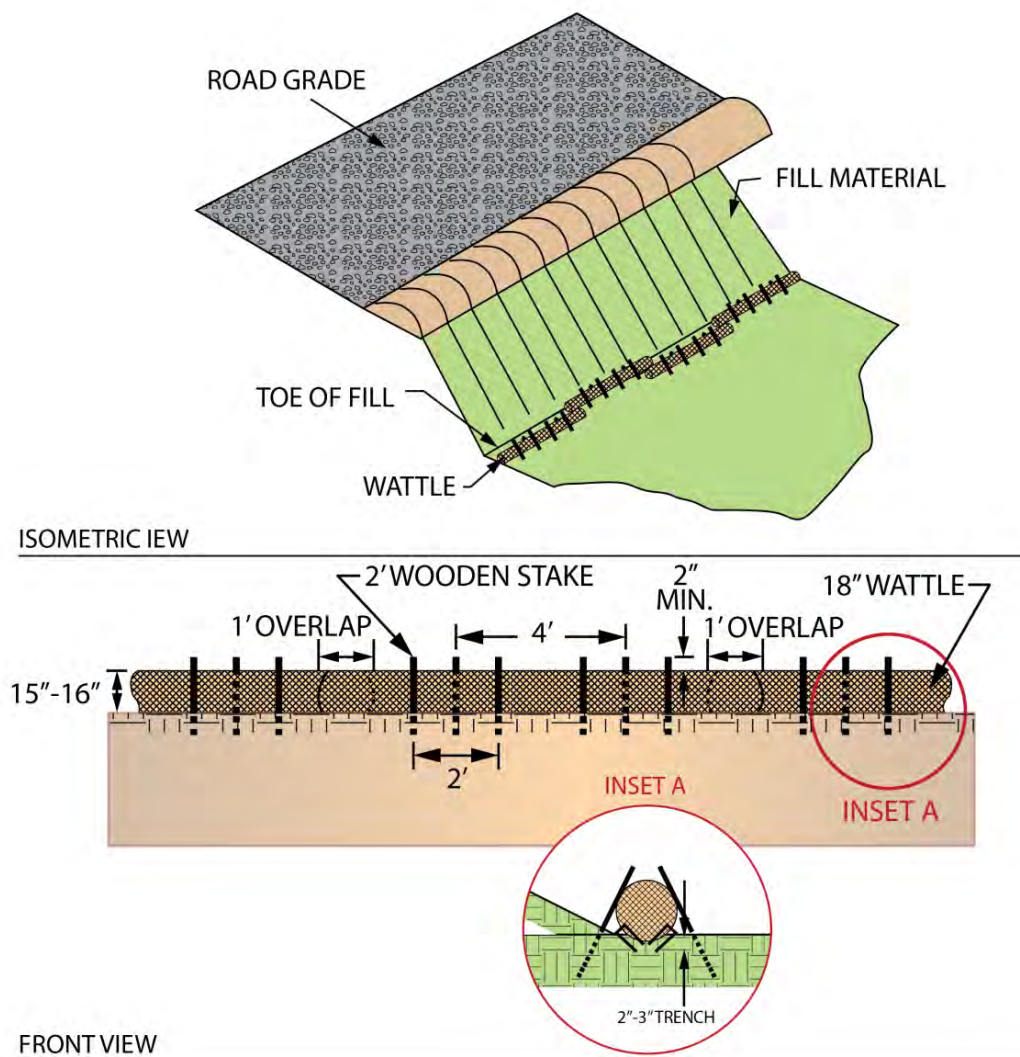

## 4.4.4 Wattle Barrier

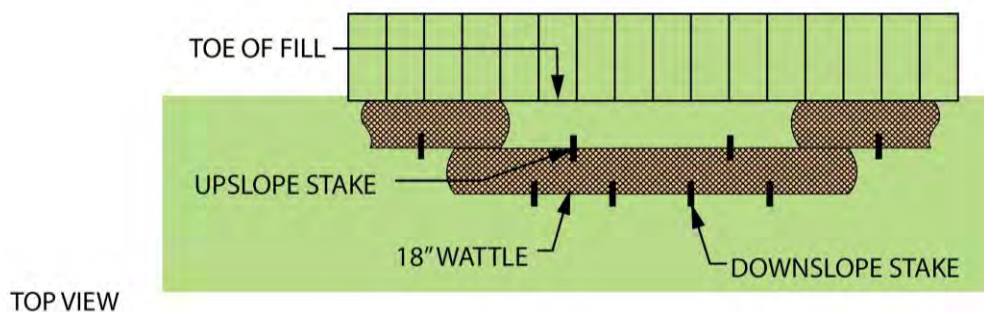

### Material Specifications

Staples shall meet the requirements of Section 1605-2 of the Standard Specifications.

#### Excelsior Wattle Barrier

- The inner material is composed of curled wood.
- The diameter shall be a minimum of 18 inches.
- The length shall be a minimum of 10 feet.
- The density of the excelsior wattle shall be 2.9 lb/ft<sup>3</sup> +/- 10%.
- For slope breaks, 12-inch diameter wattles can be used.

#### Coir Fiber Wattle Barrier

- The inner material is composed of coconut fibers.
- The diameter shall be a minimum of 18 inches.
- The length shall be a minimum of 10 feet.
- The density of the coir fiber wattle shall be 5 lb/ft<sup>3</sup> +/-10%.
- For slope breaks, 12-inch diameter wattles can be used.

## 4.4.4 Wattle Barrier

### Construction Specifications

Work includes furnishing materials, installation, maintenance and removing wattle barriers. Install barrier in conformance with details provided in the plans and as directed. Remove and dispose of silt accumulations at the wattle barriers when directed and in accordance with Section 1630 of the Standard Specifications.

<b>Spacing</b>	<ul style="list-style-type: none"> <li>Wattle barriers used to reduce runoff velocity along large slopes should have a maximum spacing of 20 feet measured along the slope.</li> </ul>
<b>Staples</b>	<ul style="list-style-type: none"> <li>Provide staples made of 0.125-inch diameter steel wire formed into a U-shape, no less than 12 inches in length and with a throat of 1 inch in width.</li> <li>Install staples approximately every 1 foot on both sides of the wattle and at each end to secure it to the soil.</li> </ul>
<b>Stakes</b>	<ul style="list-style-type: none"> <li>Use 2-foot wooden stakes with a 2-inch by 2-inch nominal cross section.</li> <li>Sharpen or bevel one end of the stake to facilitate driving down into the underlying soil.</li> <li>Install a minimum of 2 upslope stakes and 4 downslope stakes at an angle to wedge wattle to bottom of ditch.</li> <li>Drive stakes into the ground a minimum of 10 inches with no more than 2 inches projecting from the top of the wattle.</li> </ul>
<b>Overlap</b>	<ul style="list-style-type: none"> <li>Align wattle barriers in an overlapping and alternating pattern.</li> <li>Overlap adjoining sections of wattles a minimum of 1 foot.</li> <li>Excavate a trench the entire length of each wattle with a depth of 2 inches to 3 inches for the wattle to be placed.</li> </ul>

### Technician's Checklist

- Devices should be inspected regularly and after significant rainfall.
- Sediment, debris, straw and other items should be removed from the wattle barrier.
- Proper installation of anchors securing wattle barriers to the ground should be verified.

**The construction of wattle barriers is of the utmost importance in that they are designed as slope protection to reduce velocity and as a method to introduce flocculant for turbidity control.**

## 4.4.4 Wattle Barrier

### Measurement & Payment

Wattle barrier will be measured and paid for by the number of linear feet of wattles which are installed and accepted. Such price and payment will be full compensation for all work covered by this section, including furnishing all materials, labor, equipment and incidentals necessary to install the wattle barrier

#### Wattle Barrier

##### Pay Items

##### Pay Units

Wattle Barrier

Linear Foot

#### Coir Fiber Wattle Barrier

##### Pay Items

##### Pay Units

Coir Fiber Wattle Barrier

Linear Foot

### Maintenance

It is important that the wattle barriers be kept clean to allow water to flow through the natural fibers. The wattle barriers can become blocked with debris, sediment, straw and other items.

- The up gradient side of the wattle barrier should be maintained to allow the water to flow through, reduce velocity and allow sedimentation to occur.
- If the natural fibers of the wattle barrier become too saturated with debris, sediment, etc., and removal of these items is not possible, wattle barriers should be replaced.
- Stakes should be used to anchor the wattle barrier adequately to the ground to prevent scouring and washout during storm events.

**Wattle barriers are easier to remove and dispose of than measures containing stone.**

### Typical Problems

- Improper installation and failure to properly anchor the wattle barrier with staples and stakes reduces the effectiveness of the measure to control erosion and reduce velocities.
- Improper maintenance can limit the wattle barrier's effectiveness to reduce velocity.
- Stakes should not be installed through the wattle barrier.

# 4.5

## Section

### Runoff Conveyance Management

	Wattles	4.5.1
	Temporary Rock Silt Check - Type A	4.5.2
Temporary Rock Silt Check - Type A with Excelsior Matting and Flocculant		4.5.3
	Temporary Rock Silt Check - Type B	4.5.4
	Clean Water Diversion	4.5.5

*Also see Rolled Erosion Control Products in Section 4.4*

Runoff management conveyances should be considered early in the planning phase. BMPs in runoff management conveyances are used to control runoff velocity, trap silt, and in some measures, introduce flocculant to the runoff. Runoff management conveyance measures are typically placed in channels, ditches and ditch outlets.

When possible, flocculant should be added to BMPs such as the Temporary Rock Silt Check - Type A and wattle, when sediment storage requirements cannot be achieved and to provide additional stormwater runoff treatment.

## 4.5.1 Wattles



### Definition

A wattle is a tubular product consisting of excelsior or coir (coconut) fibers encased in synthetic or biodegradable netting.

### Areas of Use

Install wattles in these locations:

- In areas to reduce runoff velocity in temporary and permanent ditches
- On slopes to intercept runoff and act as a velocity break
- As inlet and outlet protection and perimeter controls
- In silt fence breaks to provide a drainage break along silt fence
- As perimeter barriers in lieu of silt fence
- As slope breaks along large slopes

Apply flocculant to wattles at these locations:

- Up gradient areas that drain to a silt fence, sediment basin or trap, rock dam or inlet protection
- Inlets that drain to sediment basins or slope drains
- Not in jurisdictional areas (streams, wetlands or ponds), as perimeter measures, at outlets of ditches or drainage inlets carrying flow directly offsite

### Practical Tips

- Wattles are primarily used for flocculant incorporation.
- Excelsior wattles are used for short-term projects.
- Coir fiber wattles are used for long-term projects.

**Wattles can provide velocity control and sediment storage as additional benefits.**

## 4.5.1 Wattles



### Design Criteria

#### Contract Projects

- Use with flocculant at 50-foot intervals in ditch lines draining directly to jurisdictional streams and wetlands
- Use with flocculant at 50-foot intervals in areas where sediment basins are not feasible at drainage outlets
- Use with flocculant at 50-foot intervals in areas where sediment basins at drainage outlets with sediment traps cannot be properly tied into existing surface areas
- Use with flocculant at 50-foot intervals in areas where sediment storage requirements are needed but construction limitations such as safety concerns, right-of-way restrictions or utility conflicts exist

**Only install wattles to a height in ditches so flow will not wash around the wattles and scour ditch slopes.**

#### Operations Projects

- 12-inch wattles should be used for typical foothill and mountain ditch lines
- At least one wattle with flocculant must be used in drainage lengths that are designed using any method other than Option 5 in EroDes
- Wattles should only be used for ditch grades of less than 2.5%
- Coir fiber wattles should be used in projects lasting longer than 1 year. The design life for excelsior wattles is 1 year.

# 4.5.1 Wattles



With Flocculant    Without Flocculant

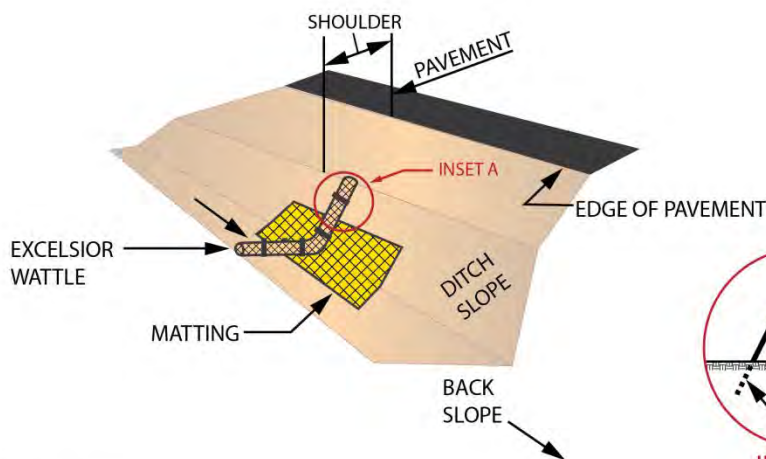

ISOMETRIC

WATTLE WITH FLOCCULANT

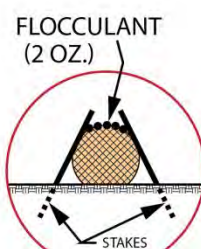

INSET A

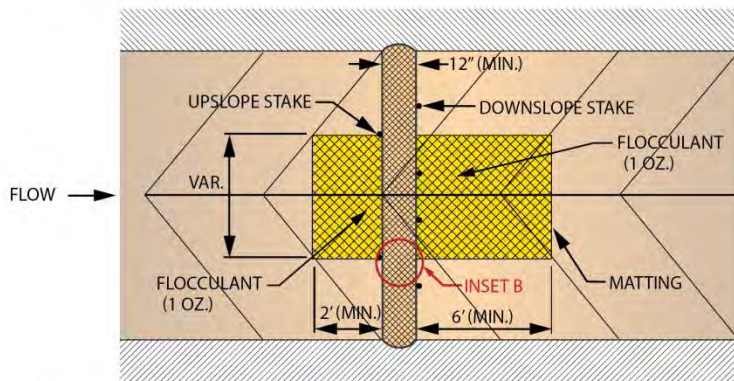

TOP VIEW

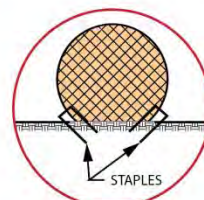

INSET B

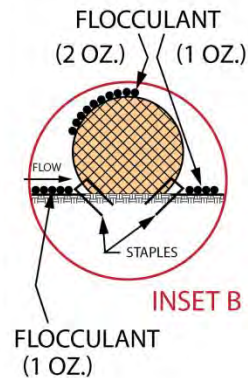

INSET B

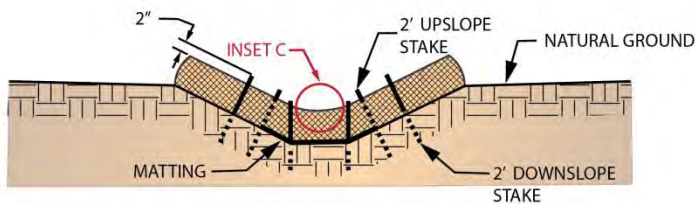

CROSS SECTION - TRAPEZOIDAL DITCH



INSET C

## 4.5.1 Wattles



### Material Specifications

Matting shall meet the requirements of Section 1060-8 of the Standard Specifications. Flocculant shall be in powder form and anionic or neutrally charged. Stakes and staples shall meet the requirements of Section 1605-2 of the Standard Specifications.

#### Excelsior Wattle

- The inner material shall be composed of curled wood.
- The diameter shall be a minimum of 12 inches and a maximum of 20 inches.
- The length shall be 10 feet.
- The density of the excelsior wattle shall be 2.5 lb/ft<sup>3</sup>.

#### Coir Fiber Wattle

- The inner material shall be composed of coconut fibers.
- The diameter shall be a minimum of 12 inches and a maximum of 20 inches.
- The length shall be 10 feet.
- The density of the coir fiber wattle shall be 3.5 lb/ft<sup>3</sup>.

### Construction Specifications

Work includes furnishing materials, installation of coir fiber wattles, matting installation and removing wattles. Installation shall follow the detail provided in the plans and as directed.

Matting	<ul style="list-style-type: none"> <li>• <b>Install matting in accordance with Section 1631 of the Standard Specifications.</b></li> </ul>
Staples	<ul style="list-style-type: none"> <li>• <b>Provide staples made of 0.125-inch diameter steel wire formed into a U-shape no less than 12 inches in length.</b></li> <li>• <b>Install staples approximately every 1 foot on both sides of the wattle and at each end to secure it to the soil.</b></li> </ul>
Stakes	<ul style="list-style-type: none"> <li>• <b>Use 2-foot wooden stakes with a 2-inch by 2-inch nominal cross section.</b></li> <li>• <b>Install a minimum of 2 upslope stakes and 4 downslope stakes at an angle to wedge the wattle to the bottom of the ditch.</b></li> <li>• <b>Drive stakes into the ground a minimum of 10 inches with no more than 2 inches projecting from the top of the wattle.</b></li> </ul>

## 4.5.1 Wattles



### Construction Specifications, cont.

Flocculant	<ul style="list-style-type: none"> <li>Flocculant shall be in powder form and anionic and neutrally charged.</li> <li>Soil samples should be obtained from areas where wattles will be placed and from off-site material used to construct the roadway. Samples should be analyzed to determine the appropriate flocculant to be used in each wattle.</li> <li>Flocculant used should be listed on the NCDENR DWR website as an approved product for use in North Carolina.</li> <li>Flocculant should be applied over the lower center portion of the wattle where the water will flow at a rate of 2 ounces per wattle.</li> <li>Apply 1 ounce of flocculant on each side of the wattle.</li> <li>Flocculant should be evaluated and applied after every rainfall event that is equal to or exceeds 0.5 inches.</li> </ul>
Overlap	<ul style="list-style-type: none"> <li>Overlap adjoining sections of wattles a minimum of 1 foot.</li> </ul>

### Technician's Checklist

- Devices should be inspected regularly and after significant rainfall.
- Flocculant should be reapplied after rainfall events equal to or exceeding 0.5 inches.
- Sediment, debris, straw and other items should be removed from the wattle.
- Proper installation of anchors to secure wattles to the ground should be verified.

**The construction of wattles is of utmost importance in that they are designed to reduce velocity and introduce flocculant for turbidity control.**

### Measurement & Payment

Wattles will be measured and paid for by the number of linear feet of wattles which are installed and accepted. Such price and payment will be full compensation for all work covered by this section, including furnishing all materials, labor, equipment and incidentals necessary to install the wattles.

Matting will be measured and paid for in accordance with Section 1631-4 of the Standard Specifications, or in accordance with specifications provided elsewhere in this contract.

## 4.5.1 Wattles



Flocculant will be measured and paid for by the actual weight in pounds of flocculant applied to the wattles. Such price and payment will be full compensation for all work covered by this section, including furnishing all materials, labor, equipment and incidentals necessary to apply the flocculant.

### Wattle

Pay Items	Pay Units
Wattle	Linear Foot
Matting for Erosion Control	Square Yard
Flocculant	Pound

### Coir Fiber Wattle

Pay Items	Pay Units
Coir Fiber Wattle	Linear Foot
Matting for Erosion Control	Square Yard
Flocculant	Pound

### Maintenance

It is important that the wattles be kept clean to allow water to flow through the natural fibers and contact the flocculant. The wattles can become blocked with debris, sediment, straw and other items.

- The upstream side of the wattle should be maintained to allow the water to flow through, reduce velocity, distribute flocculant and allow sedimentation to occur.
- If the natural fibers of the wattle become too saturated with debris, sediment, etc., and removal of these items is not possible, wattles should be replaced.
- Stakes should be used to anchor the wattle adequately to the ground to prevent scouring and washout during storm events.
- The excelsior pad beneath the wattles is critical to the proper functioning of the wattles.

**Wattles are easier to remove and dispose of than stone.**

## 4.5.1 Wattles



### Typical Problems

- Improper installation and failure to properly anchor the wattle with staples and stakes reduces the effectiveness of the measure to control erosion and reduce velocities.
- Improper maintenance can limit the wattle's effectiveness to reduce velocity and distribute flocculant in runoff.
- Failure to install excelsior pad can limit the wattle's effectiveness.
- Stakes should not be installed through the wattle.

## 4.5.2 Temporary Rock Silt Check - Type A



### Definition

Temporary Rock Silt Checks - Type A (TRSC-A) are small dam structures with a distinguishable weir outlet. They reduce the water velocity and provide sufficient capacity to trap silt in existing and proposed ditches. They are utilized as drainage outlets in concentrated flow areas where sediment basins and dams are not feasible.

### Areas of Use

- In temporary and permanent ditches to reduce runoff velocity
- In outlets of temporary diversions, temporary silt ditches, channels and temporary slope drains
- In Environmentally Sensitive Areas (ESAs) where excavation is not permitted and storage capacity is limited
- Where the TRSC-A's can be easily cleaned and maintained
- Where runoff is exiting the project and larger sediment devices are not feasible, such as drainage turnouts

### Practical Tips

- A pile of stone dumped into a ditch line does not constitute a proper rock silt check.
- TRSC-A's should be built in the same manner as temporary rock sediment dams. Rather than a defined sediment area, the TRSC-A uses a natural formed pit for storage.

**TRSC-A's can be combined with temporary silt fence for use in ESAs and wetlands which will allow for drainage of accumulated flow behind the fence.**

## 4.5.2 Temporary Rock Silt Check - Type A



and natural drainage patterns

### Design Criteria

- The drainage area should be 1 acre or less.
- The volume should be designed for 3,600 cubic feet per acre of disturbance.
- The sediment storage capacity should be limited to 275 cubic feet.
- TRSC-A's should be used on short and long-term projects where the ditch grade is greater than 2.5%.

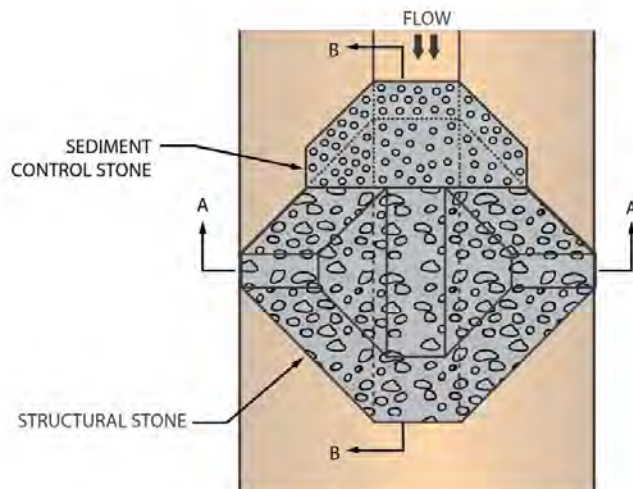

PLAN VIEW (NOT TO SCALE)

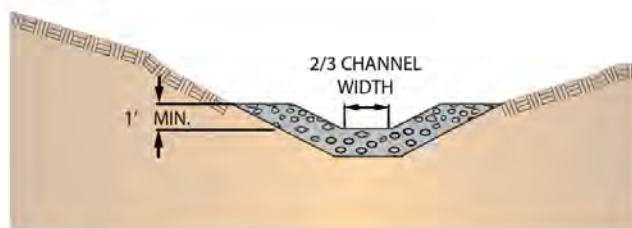

CROSS SECTION A-A (NOT TO SCALE)

## 4.5.2 Temporary Rock Silt Check - Type A

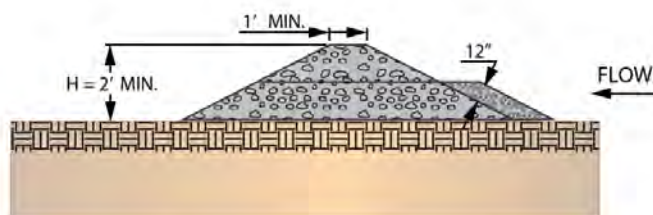

CROSS SECTION B-B (NOT TO SCALE)

### Material Specifications

- Structural stone shall be Class B stone that meets the requirements of Section 1042 of the Standard Specifications for Stone for Erosion Control, Class B.
- Sediment control stone shall be No.5 or No.57 stone, which meets the requirements of Section 1005 of the Standard Specifications for these stone sizes.

### Construction Specifications

The construction of temporary rock silt checks is of the utmost importance in that they are designed to slow down and therefore pond water on the upstream side. This creates hydraulic pressure and water will try to get over, under, around and/or through the check.

**A rule of thumb for placing ditch checks is that they are placed where the base of the upstream dam is not higher than the top of the downstream dam.**

## 4.5.2 Temporary Rock Silt Check - Type A



<b>Structural Stone</b>	<ul style="list-style-type: none"> <li>• Use Class B structural stone.</li> <li>• Install stone at a minimum depth of 12 inches.</li> <li>• Install sediment control stone on the up gradient face of the structural stone.</li> </ul>
<b>Side Slopes</b>	<ul style="list-style-type: none"> <li>• 2:1 or flatter</li> </ul>
<b>Weir</b>	<ul style="list-style-type: none"> <li>• Weir length should be 2/3 of the channel width.</li> <li>• The weir height shall be a minimum of 1 foot.</li> <li>• The depth of the weir shall be a minimum of 1 foot.</li> </ul>

It is important that the water be directed where it will not cause additional erosion under or around the sides of the check. For this reason, the weir must be properly sized and built. No value is received from stone that is placed on the sides higher than the expected high water elevation.

### Technician's Checklist

- Build checks at the frequency shown in the Erosion and Sediment Control Plans.
- Install weir sections to allow water to flow over the stone, not around it.
- Construct the elevation of the weir 1-foot lower than the elevation where the stone ties into the ditch banks.
- Install a silt basin, if needed, up gradient of the check.
- Once the checks shown on the plans are installed, determine if there are a sufficient number to keep the velocity of the water low enough to minimize erosion of the ditch.
- Keep the checks clean.

### Measurement & Payment

<b>Pay Item:</b>	<b>Pay Unit:</b>
Stone for Erosion Control, Class B	Ton
Sediment Control Stone, Standard Size No. 5 or No. 57	Ton
Silt Excavation	Cubic Yard

## 4.5.2 Temporary Rock Silt Check - Type A



### Maintenance

It is important that the checks be kept clean and allow the water to flow through the stone because they are intended to pond water for only a short period of time. These checks can become clogged with silt, straw, grass clippings and other items.

- Inspect the device after each significant rainfall.
- At a minimum, remove silt from the device when silt accumulates to one-half the height of the weir.
- Replace or clean sediment control stone when water no longer drains through the device between rainfall events.
- Rebuild and reshape rock weir and check when the device is damaged.

**It is not proper, when maintaining the device, to just add stone to the face of the clogged device instead of cleaning the existing stone. The clog will remain if not cleaned.**

### Device Removal

The determination to remove a rock silt check device from service should be made after considering whether there is any advantage to the division maintenance forces to leave it in place. Many times, the completed project will not become stable from an erosion control standpoint for some time, so some of the temporary devices may need to be left in place and removed by Department forces at a later date. If the device is to be left on the project after its completion, the device must be clean and in proper shape at the time of the final inspection. If it is to be removed, all accumulated silt should be removed and the area dressed and seeded.

### Typical Problems

- Silt accumulation is not removed when needed.
- Rock structure is not rebuilt when damaged by storms and equipment.
- Rock structure and weir are not constructed to specifications.
- Rock structure is constructed higher than the drainage ditch causing water to flow around the measure and erode the ditch.
- Rock structure is not built wide enough to intercept the ditch slope at the top of the TRSC-A.

## 4.5.3 Temporary Rock Silt Check - Type A with Excelsior Matting and Flocculant



### Definition

Temporary Rock Silt Checks - Type A (TRSC-A) with excelsior matting and flocculant are small dam structures with a distinguishable weir outlet. They reduce the water velocity, provide sufficient capacity to trap silt and introduce flocculant into the runoff.

### Areas of Use

- In temporary and permanent ditches to reduce runoff velocity and incorporate flocculant
- Where the TRSC-A's can be easily cleaned and maintained
- In up gradient areas to incorporate flocculant into the runoff where sediment storage requirements cannot be achieved and designed structure length and width are at a maximum

### Design Criteria

- The drainage area should be 1 acre or less.
- TRSC-A's should be placed with excelsior matting and flocculant every 50 feet or spaced appropriately, in temporary and permanent ditches.
- TRSC-A's should be used on short and long-term projects where the ditch grade is greater than 2.5%.

### Practical Tips

- A pile of stone dumped into a ditch line does not constitute a proper rock silt check.
- TRSC-A's with excelsior matting and flocculant should be placed in existing and proposed ditches up gradient of the final drainage outlet measure. Do not use as an outlet device!

## 4.5.3 Temporary Rock Silt Check - Type A with Excelsior Matting and Flocculant

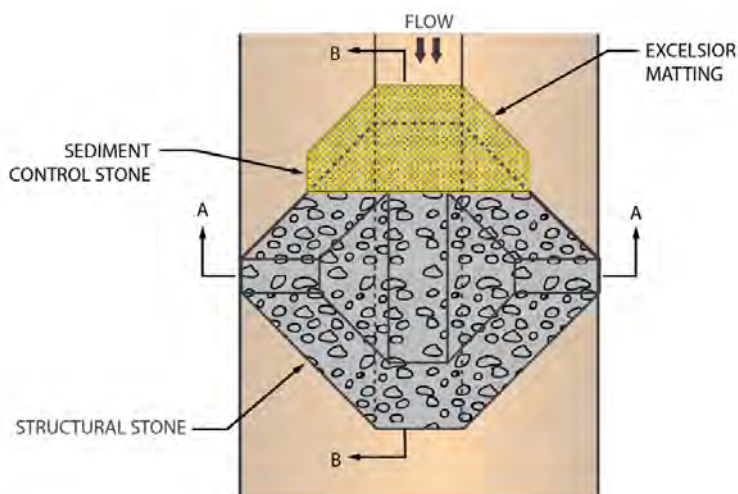

PLAN VIEW (NOT TO SCALE)



CROSS SECTION A-A (NOT TO SCALE)

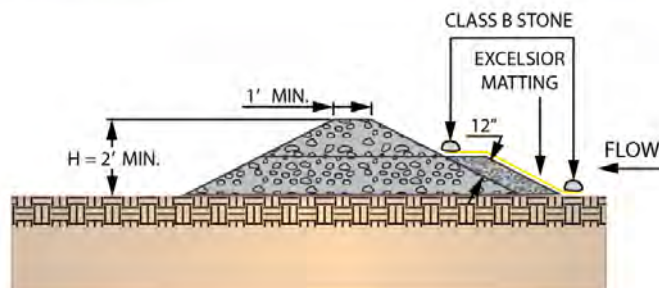

CROSS SECTION B-B (NOT TO SCALE)

## 4.5.3 Temporary Rock Silt Check - Type A with Excelsior Matting and Flocculant



### Material Specifications

- Structural stone shall be Class B stone that meets the requirements of Section 1042 of the Standard Specifications for Stone for Erosion Control, Class B.
- Sediment control stone shall be No.5 or No.57 stone, which meets the requirements of Section 1005 of the Standard Specifications for these stone sizes.
- Excelsior matting shall meet the requirements of NCDOT's Standard Specifications Section 1631.01.
- Flocculant shall be in powder form and anionic or neutrally charged.

### Construction Specifications

The construction of temporary rock silt checks is of the utmost importance in that they are designed to slow down and therefore pond water on the upstream side. This creates hydraulic pressure and water will try to get over, under, around and/or through the check.

**A rule of thumb for placing checks is that they are placed where the base of the upstream dam is not higher than the top of the downstream dam.**

<b>Structural Stone</b>	<ul style="list-style-type: none"> <li>• Use Class B structural stone.</li> <li>• Install stone at a minimum depth of 12 inches.</li> <li>• Install sediment control stone on the up gradient face of the structural stone.</li> </ul>
<b>Side Slopes</b>	<ul style="list-style-type: none"> <li>• 2:1 or flatter</li> </ul>
<b>Weir</b>	<ul style="list-style-type: none"> <li>• Weir length should be 2/3 of the channel width.</li> <li>• The weir height shall be a minimum of 1 foot.</li> <li>• The depth of the weir shall be a minimum of 1 foot.</li> </ul>
<b>Matting</b>	<ul style="list-style-type: none"> <li>• Install over sediment control stone on the up gradient side of the TRSC-A.</li> <li>• Anchor excelsior section at top and bottom with Class B stone.</li> </ul>
<b>Flocculant</b>	<ul style="list-style-type: none"> <li>• Prior to the flocculant application, obtain a soil sample from the project location, and from the off-site material, and analyze for appropriate flocculant to be applied to each rock silt check.</li> <li>• Initially apply 4 ounces of flocculant to the face of the excelsior and also after every rainfall event that equals or exceeds 0.50 inches.</li> <li>• Flocculant used should be listed on the NCDENR DWR website as an approved product for use in North Carolina</li> </ul>

## 4.5.3 Temporary Rock Silt Check - Type A with Excelsior Matting and Flocculant



It is important that the water be directed where it will not cause additional erosion under or around the sides of the check. For this reason, the weir must be properly sized and built. No value is received from stone that is placed on the sides higher than the expected high water elevation.

### Technician's Checklist

- Build checks at the frequency shown in the Erosion and Sediment Control Plans.
- Install weir sections to allow water to flow over the stone, not around it.
- Construct the elevation of the weir 1-foot lower than the elevation where the stone ties into the ditch banks.
- Flocculant should be reapplied after rainfall events equal to or exceeding 0.5 inches.
- Install a silt basin, if needed, up gradient of the check.
- Once the checks shown on the plans are installed, determine if there are a sufficient number to keep the velocity of the water low enough to minimize erosion of the ditch.
- Keep the checks clean.

### Measurement & Payment

When the silt is removed from in front of the check, it is paid for as "Silt Excavation." There is no additional pay for maintaining or removing the device.

Pay Item:	Pay Unit:
Stone for Erosion Control, Class B	Ton
Sediment Control Stone, Standard Size No. 5 or No. 57	Ton
Silt Excavation	Cubic Yard
Matting for Erosion Control	Square Yard
Flocculant	Pound

## 4.5.3 Temporary Rock Silt Check - Type A with Excelsior Matting and Flocculant



### Maintenance

It is important that the checks be kept clean and allow the water to flow through the stone because they are intended to pond water for only a short period of time. These checks can become clogged with silt, straw, grass clippings and other items.

- Inspect the device after each significant rainfall.
- At a minimum, remove silt from the device when silt accumulates to one-half the height of the weir.
- Replace or clean sediment control stone when water no longer drains through the device between rainfall events.
- Rebuild and reshape rock weir and check when the device is damaged.

**It is not proper, when maintaining the device, to just add stone to the face of the clogged device instead of cleaning the existing stone. The clog will remain if not cleaned.**

### Device Removal

The determination to remove a rock silt check device from service should be made after considering whether there is any advantage to the division maintenance forces to leave it in place. Many times, the completed project will not become stable from an erosion control standpoint for some time, so some of the temporary devices may need to be left in place and removed by Department forces at a later date. If the device is to be left on the project after its completion, the device must be clean and in proper shape at the time of the final inspection. If it is to be removed, all accumulated silt should be removed and the area dressed and seeded.

### Typical Problems

- Silt accumulation is not removed when needed.
- Rock structure is not rebuilt when damaged by storms and equipment.
- Rock structure and weir are not constructed to specifications.
- Rock structure is constructed higher than the drainage ditch causing water to flow around the measure and erode the ditch.
- Rock structure is not built wide enough to intercept the ditch slope at the top of the TRSC-A.
- Improper maintenance can limit the wattle's effectiveness to reduce velocity and distribute flocculant in runoff.

## 4.5.4 Temporary Rock Silt Check - Type B (1633.02)



### Practical Tips

- A rule of thumb for placing Type B Temporary Rock Silt Checks is to place them where the base of the upstream dam is not higher than the top of the downstream dam.

### Definition

A Temporary Rock Silt Check Type - B (TRSC-B), also referred to as a check dam, is a small dam with a distinguishable weir. The primary purpose of this device is to reduce erosion in a drainage ditch by restricting the velocity of flow in the channel. They are constructed of Class B stone and typically used in ditches during construction where the grade meets or exceeds 2.5%.

### Areas of Use

Install TRSC-B's in drainage ditches to reduce runoff velocity. TRSC-B's can be applied at the following:

- In channels, roadside ditches, temporary silt ditches and temporary diversions
- In temporary channels that are susceptible to erosion but where permanent stabilization is impractical due to their limited duration of use
- In eroding channels where construction delays or weather conditions prevent timely installation of non-erosive liners
- In conjunction with Type B silt basin

### Design Criteria

- The drainage area shall be limited to ½ acre or less to each TRSC-B in a ditch line.
- TRSC-B spacing should be  $(2.5 \div \% \text{ of ditch grade}) \times 100$  feet.

## 4.5.4 Temporary Rock Silt Check - Type B (1633.02)

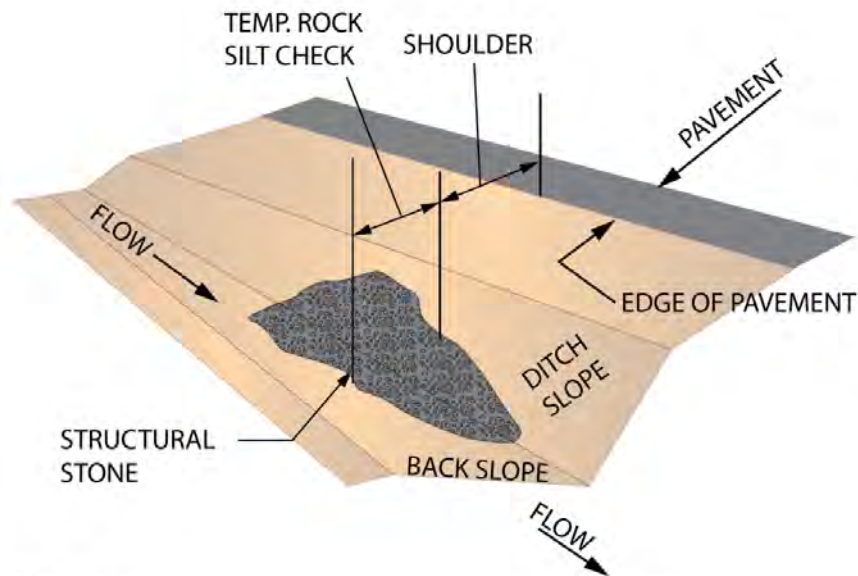

ISOMETRIC VIEW

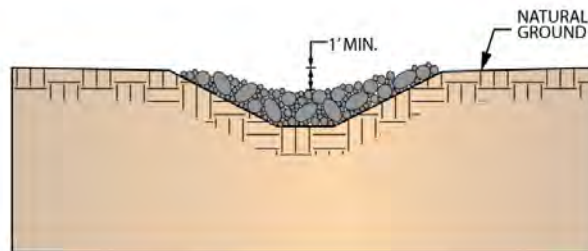

CROSS SECTION TRAPEZOIDAL DITCH

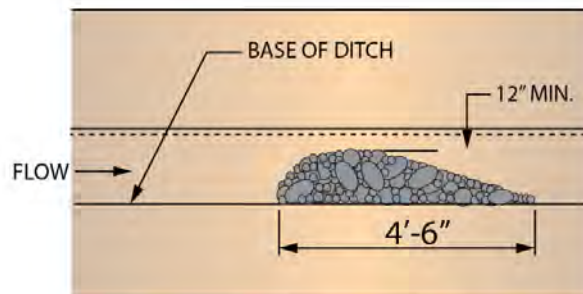

ELEVATION VIEW

## 4.5.4 Temporary Rock Silt Check - Type B (1633.02)



### Material Specifications

- Structural stone shall be Class B stone that meets the requirements of Section 1042 of the Standard Specifications for Stone for Erosion Control, Class B.

**Make sure the weir is properly constructed and positioned so that water flow will be directed where it will not cause additional erosion under or around the sides of the check.**

### Construction Specifications

<b>Installation</b>	<ul style="list-style-type: none"> <li>• The center of the rock silt check shall be at least 1-foot lower than the outer edges (top of the channel sides).</li> <li>• The maximum height at the center of the rock check should not exceed 2 feet.</li> <li>• The side slopes of the check shall be 2:1 or flatter.</li> </ul>
<b>Slope</b>	<ul style="list-style-type: none"> <li>• Maximum spacing between the checks should place the toe of the upstream check at the top of the downstream check.</li> </ul>

### Technician's Checklist

- Build checks at the location shown in the Erosion and Sediment Control plans.
- Install weir sections to permit water to flow over the stone, not around it.
- Construct the elevation of the top of device lower than the elevation where the stone ties into the ditch banks.
- Install a silt basin, if needed, just upstream of the check.
- Once the checks are installed as shown on the plans, determine if there are a sufficient number to keep the velocity of the runoff low enough to minimize erosion of the ditch.
- Keep the checks clean.

### Measurement & Payment

When the silt is removed from in front of the check, it is paid for as "Silt Excavation." There is no additional pay for maintaining or removing the device.

#### Pay Items

Stone for Erosion Control Class B  
Silt Excavation

#### Pay Units

Ton  
Cubic Yard

## 4.5.4 Temporary Rock Silt Check - Type B (1633.02)



### Maintenance

It is important that these checks be kept clean and allow the water to flow through the stone because they are designed to pond water for only a short period of time. These checks can become plugged with silt, straw, grass clippings and other items. It is not appropriate to add stone to the face of a plugged check instead of cleaning the existing stone. The clog will remain.

- Inspect rock check after each significant rainfall
- Remove silt from device when it accumulates
- Rebuild and reshape device and weir when damaged or as necessary
- Cleanout when clogged by straw, limbs or other debris

**Consider whether there is any advantage to leaving the rock check in place permanently before removing it.**

### Device Removal

Often, a completed project will not become stable from an erosion control standpoint for some time, so some of the temporary devices may need to be left in place and removed by Department forces at a later date. If the device is left on the project after its completion, the device must be clean and in proper shape at the time of the final inspection. If it is removed, all accumulated silt should be removed and the area dressed and seeded.

### Typical Problems

- Rock silt check is not rebuilt when damaged by storms, equipment, etc.
- Rock silt check and weir section not constructed properly
- Rock silt checks are not constructed higher than drainage ditch, causing water to flow around the measure allowing erosion of the channel
- Rock silt checks not built wide enough to intercept ditch slope at top of rock check
- Maintenance not performed in a timely manner, allowing the buildup of silt accumulation and debris that makes the rock silt check ineffective
- Improper spacing allows velocity to build and erode channel

## 4.5.5 Clean Water Diversion

→ CWD →



### Definition

A clean water diversion is a conveyance system that is used to intercept sheet flow up gradient of a project site, transport it around the construction site and discharge it in a manner that minimizes water quality and environmental impacts.

### Areas of Use

Install clean water diversions in the following locations:

- For isolating construction activities near water bodies, such as streambank stabilization, culvert or bridge installation
- In locations outside of cut and fill areas
- In areas parallel to the right-of-way

### Practical Tips

- Clean water diversions are used to direct water flowing from off site around or away from a specific area of construction.
- These are also used to reduce the size of drainage areas.

### Velocity Control:

- Place Type B rock silt checks every 2 feet of elevation change
- Do not use wattles
- Utilize temporary piping for terrain greater than 8%
- Place Temporary Rock Silt Check Type A at outlets

## 4.5.5 Clean Water Diversion



### Design Criteria

- Clean water diversions are used on clearing and grubbing and final grade phases of erosion and sediment control plans.
- The grade should be limited to prevent erosive velocities.
- The capacity of the clean water diversion should accommodate the peak runoff from a 10-year storm.
- The liner for the diversion should be designed to stabilize erosive forces.
- Devices utilizing flocculant should not be designed with clean water diversions.

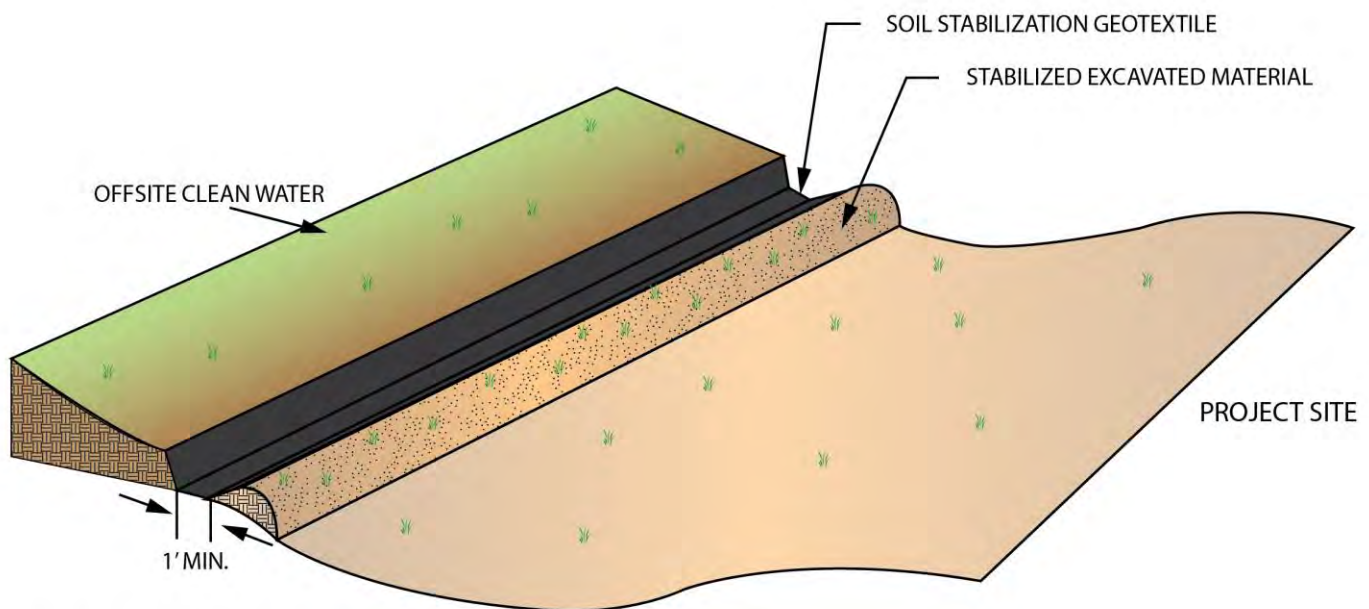

ISOMETRIC VIEW

## 4.5.5 Clean Water Diversion

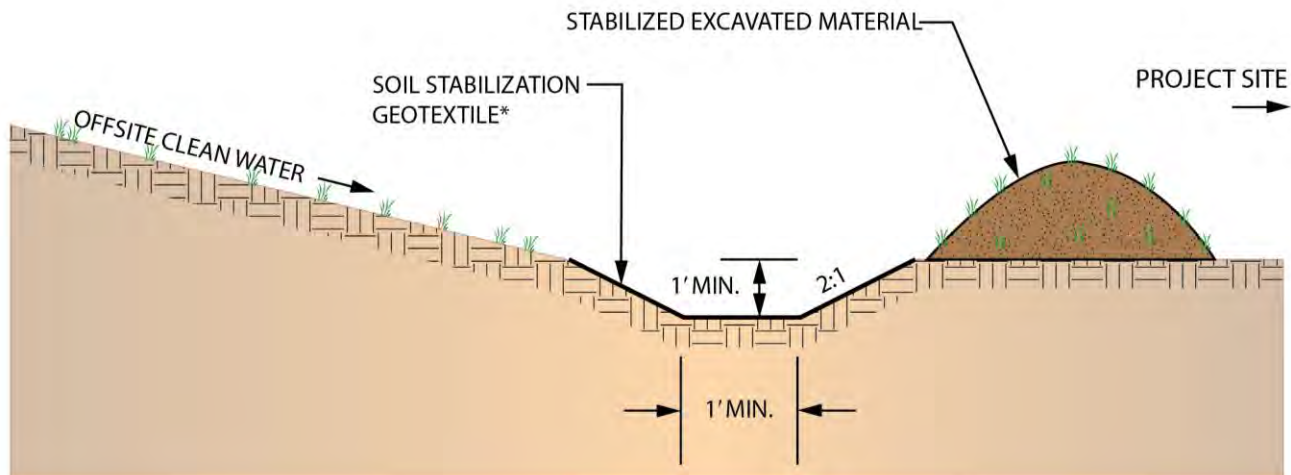

### CROSS SECTION (NOT TO SCALE)

\* Geotextile fabric should extend up and over the inside face of the berm for projects with jurisdictional trout waters.

### Material Specifications

- Silt excavation shall meet the requirements of Section 1630-3 of the Standard Specifications.
- The geotextile shall meet the requirements of Section 1056 of the Standard Specifications for Type 4 Geotextile.
- Proper geotextile certifications are required to meet Section 1056 of the Standard Specifications.
- Stabilization of the excavated materials shall meet the requirements of Section 1620 of the Standard Specifications.

## 4.5.5 Clean Water Diversion



### Construction Specifications

Geotextile	<ul style="list-style-type: none"> <li>Line the clean water diversion with geotextile unrolled in the direction of flow.</li> <li>Overlap the geotextile a minimum of 18 inches longitudinally (parallel to direction of flow) on the upgradient and downgradient ends.</li> <li>Lay the geotextile smoothly but loosely on the soil surface without creases.</li> <li>Bury the geotextile edges in a trench (parallel to direction of flow) a minimum of 5-inches deep and tamped securely.</li> <li>Secure the geotextile with 11 gauge wire staples. Staples shall be U-shaped with a minimum length of 6 inches and a minimum throat width of 1 inch.</li> <li>Place staples along the outer edges and throughout the geotextile at a maximum of 3 feet laterally and longitudinally.</li> </ul>
Excavated Material	<ul style="list-style-type: none"> <li>Excavated material should be immediately stabilized.</li> </ul>

### Technician's Checklist

- The clean water diversion should be installed in accordance with the Erosion and Sediment Control plans.
- In order for the clean water diversion to be effective, it is essential to verify that the geotextile is keyed in at the edges in an excavated trench.
- In addition to the geotextile being buried, it should be installed with the up gradient geotextile overlapping the downstream geotextile longitudinally by a minimum of 18 inches.
- The geotextile should be inspected for sediment accumulation and damage on a regular basis and after significant rain events.

**Do NOT install wattles in a clean water diversion.**

## 4.5.5 Clean Water Diversion



### Measurement & Payment

When the accumulated silt is removed along the clean water diversion, it is paid for as “Silt Excavation.” The pay items and payment listed are considered full compensation for the work, including all materials, construction, maintenance and removal of the clean water diversions.

#### Pay Items

Geotextile for Soil Stabilization, Type 4

Silt Excavation

Seed for Temporary Seeding

Fertilizer for Temporary Seeding

Seeding and Mulching

#### Pay Units

Square Yard

Cubic Yard

Pound

Ton

Acre

### Maintenance

- Inspect the clean water diversion on a regular basis and after each significant rainfall. Make any repairs immediately.
- Confirm that the geotextile is keyed in properly.
- Remove and dispose of all silt accumulations.
- Dispose of sediment by hauling it to an approved waste site with appropriate perimeter protection.
- Remove and replace deteriorated geotextile as needed.

**In order for the clean water diversion to be effective, it is essential to verify that the geotextile is buried in an excavated trench.**

### Typical Problems

- The device is installed improperly (the bottom of geotextile is not keyed in at the edges properly).
- Silt accumulates excessively and geotextile becomes impacted with sediment and other debris.
- The device is disturbed by fallen trees, rocks, equipment, excess water flows or for work access.
- Insufficient velocity controls and the outlet measure is overwhelmed by runoff and fails.

## 4.5.5 Clean Water Diversion



*This page is intentionally left blank.*

# 4.6

## Section

### Drainage System Protection

Rock Inlet Sediment Trap - Types A, B and C	4.6.1
Rock Pipe Inlet Sediment Trap - Types A and B	4.6.2

Drainage systems convey concentrated flow from the project site. These systems are vulnerable to sedimentation and can allow sediment to leave the project site unnoticed, but also offer opportunities to trap sediment. Drop and pipe inlets require additional attention to filter sediment from the stormwater before it enters these systems. Ditches also require measures to reduce stormwater velocity and filter sediment.

Drainage system protection provides opportunities for the designers, technicians and contractors to protect locations in the drainage system that have the potential to trap sediment. BMPs in this section are designed to also reduce runoff velocity of the stormwater.

## 4.6.1 Rock Inlet Sediment Trap - Types A, B and C (1632.01, 1632.02, 1632.03)

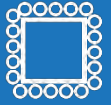

### Practical Tips

- RIST-A's are used in areas of high flow.
- RIST-B's are used in areas of moderate flow.
- RIST-C's are used in areas of low to moderate flow.

### Definition

Rock Inlet Sediment Traps (RIST) are devices constructed around the outside perimeter of inlets to provide sediment protection for the water flowing to the inlet. There are three different types of Rock Inlet Sediment Traps: Types A, B and C. Varying in sizes, Types A and B are doughnut-shaped stone dam devices constructed with a sediment stone storage area as well as a structural area of stone around the perimeter of the inlet. Type C is a hardware cloth device that also includes a smaller doughnut-shaped or rectangular-shaped stone dam structure.

## 4.6.1 Rock Inlet Sediment Trap - Types A, B and C (1632.01, 1632.02, 1632.03)

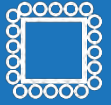

### Areas of Use

#### Rock Inlet Sediment Trap - Type A (RIST- A)

- At drop inlets that have a large drainage area
- At drop inlets that receive high velocity water flow
- At drop inlets that receive heavy water flow from one or multiple directions
- At least 30 feet from a maintained vehicular travel lane, in order to prevent a safety hazard in newly constructed medians and ditches

**Large stone size could pose a traffic hazard. Choose the device type with the proper stone size when placing rock inlet sediment traps near traffic.**

#### Rock Inlet Sediment Trap - Type B (RIST- B)

- At drop inlets where an RIST-A would be unsafe due to adjacent traffic
- At drop inlets that receive moderate to heavy flow from one or multiple directions
- At drop inlets where flow velocities are too high for an RIST-C
- Around catch basins in curb and gutter sections
- In urban areas and on widening projects
- Where there is no minimum offset distance from travel lane

#### Rock Inlet Sediment Trap - Type C (RIST- C)

- At drop inlets that receive light to moderate flow from one or multiple directions
- At drop inlet locations where flow is low enough that a RIST-B is not required
- Around catch basins in curb and gutter sections
- In urban areas with clearing and grubbing
- On widening projects
- For fill slope drainage inlets at shoulder break points

**The actual conditions which occur during construction of the project will determine the number of RISTs installed.**

## 4.6.1 Rock Inlet Sediment Trap - Types A, B and C (1632.01, 1632.02, 1632.03)

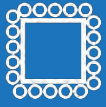

### Design Criteria

#### Type A

- If the drainage area exceeds 1 acre, then a Silt Basin - Type B is needed in conjunction with the RIST-A.
- The stone dam should be a minimum of 2-feet high.
- The top elevation of the RIST-A shall be a minimum of 12-inches lower than the ground elevation that would allow bypass.
- Because of the stone dam, the RIST-A should be placed at locations that will not create a safety hazard.

#### Type B

- If the drainage area exceeds 1 acre, then a Silt Basin - Type B is needed in conjunction with the RIST-B.
- The stone dam should be a minimum of 1.5-feet high.
- The top elevation of the RIST-B should be a minimum of 12-inches lower than the ground elevation downslope from the inlet.

#### Type C

- The drainage area should not exceed more than 1 acre.
- The stone height should be 1 foot.
- Flow velocities should be low.
- The device uses hardware cloth with a small doughnut-shaped stone structure at the base.

Types A, B and C can be modified to accommodate a drop inlet receiving water from only one direction. For Types A, B and C, a silt basin can be constructed up gradient to the device to increase the sediment storage capacity when the drop inlet is in a ditch location.

## 4.6.1 Rock Inlet Sediment Trap - Types A, B and C (1632.01, 1632.02, 1632.03)

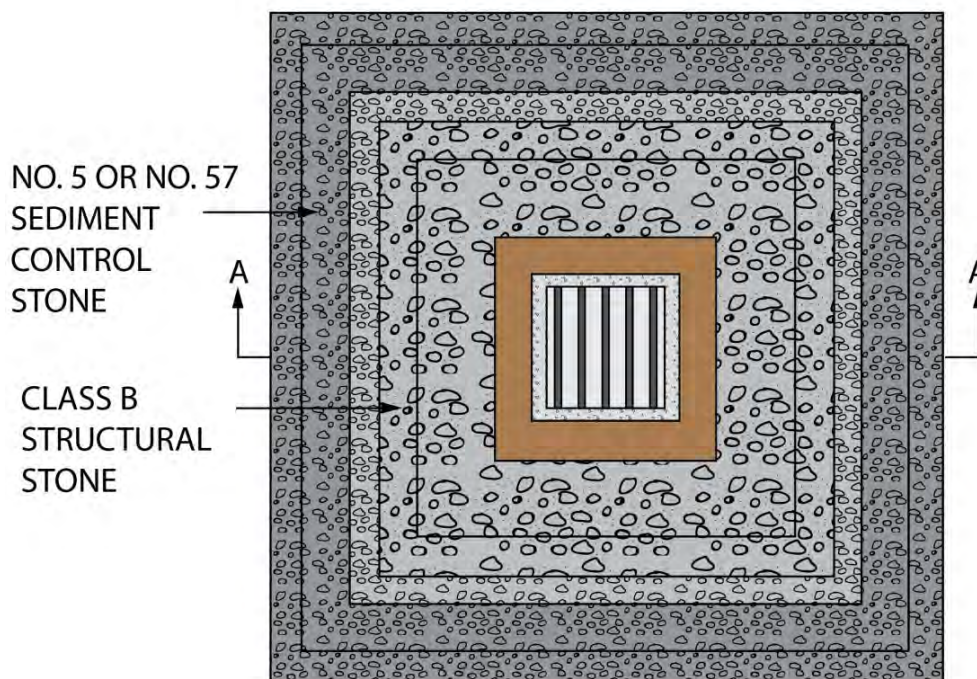
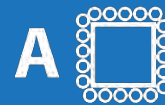

PLAN VIEW - TYPE A

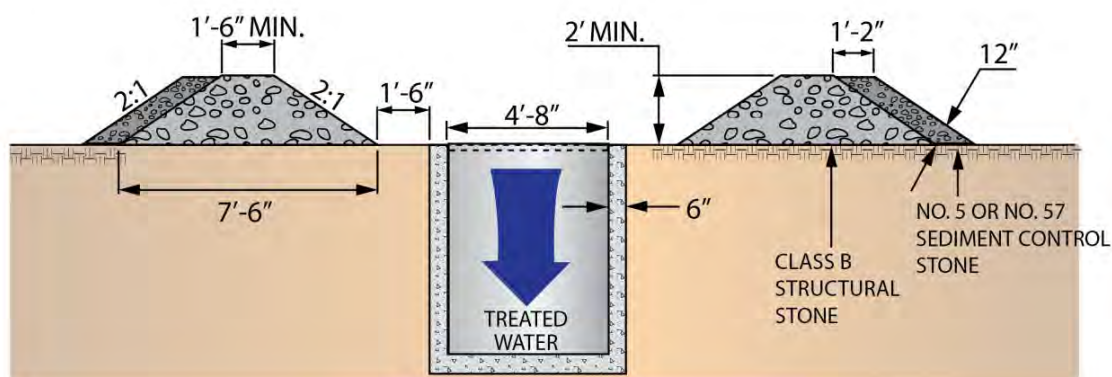

CROSS SECTION A-A - TYPE A

## 4.6.1 Rock Inlet Sediment Trap - Types A, B and C (1632.01, 1632.02, 1632.03)

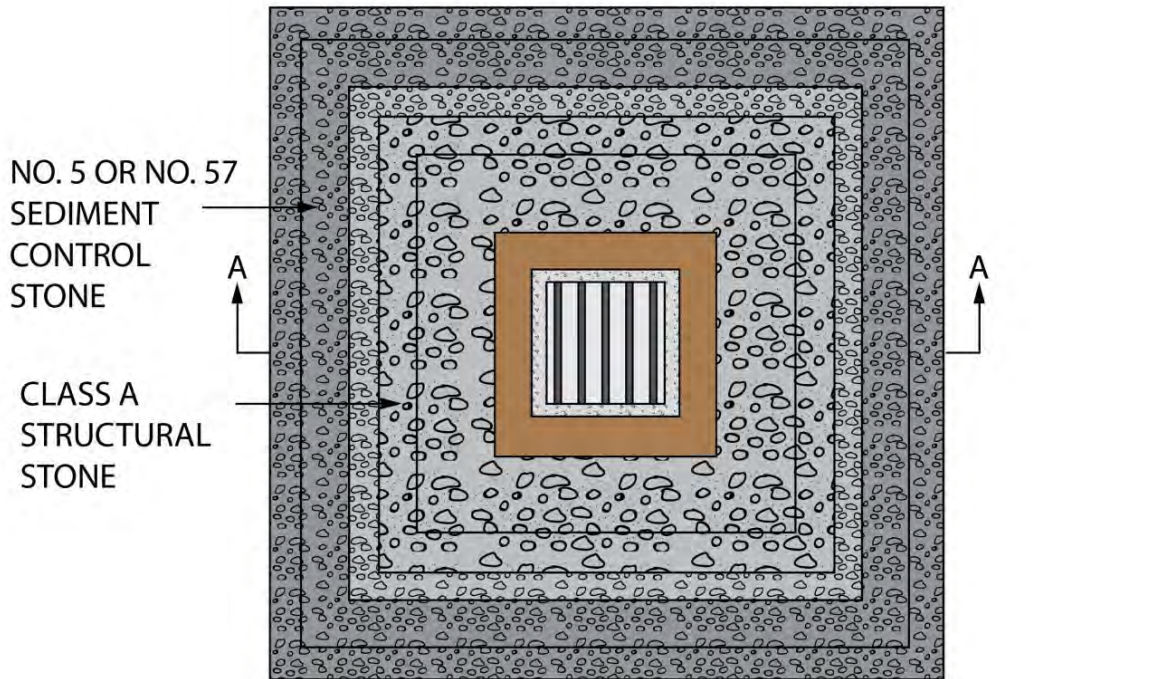
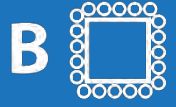

PLAN VIEW - TYPE B

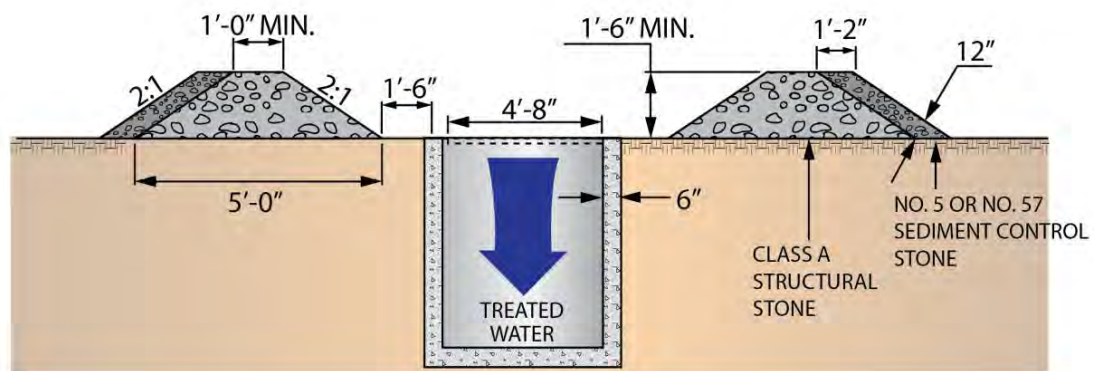

CROSS SECTION A-A - TYPE B

# 4.6.1 Rock Inlet Sediment Trap - Types A, B and C (1632.01, 1632.02, 1632.03)

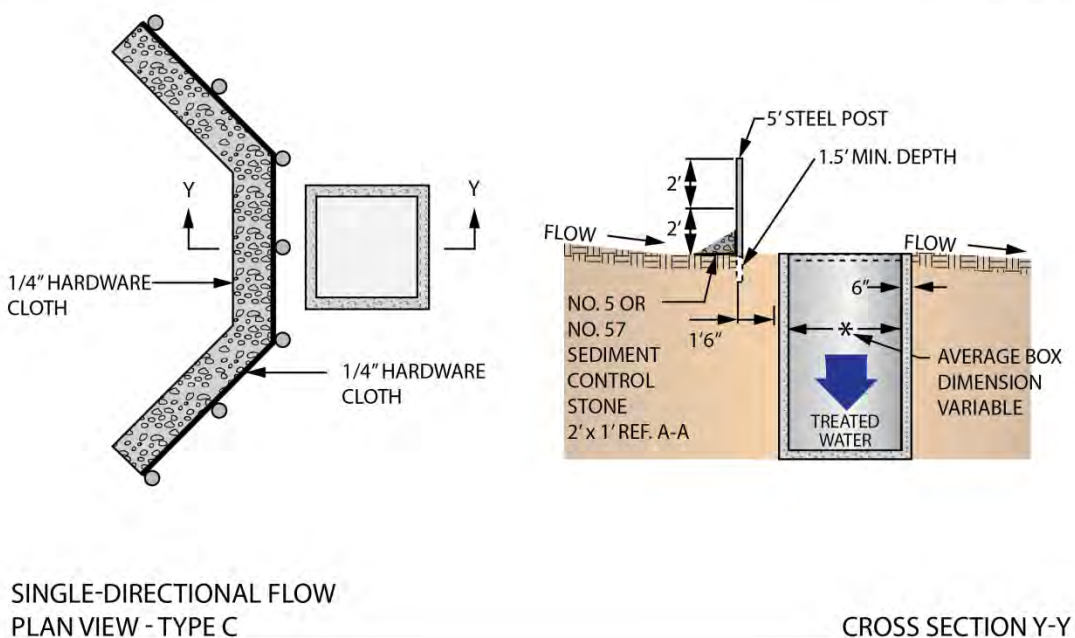
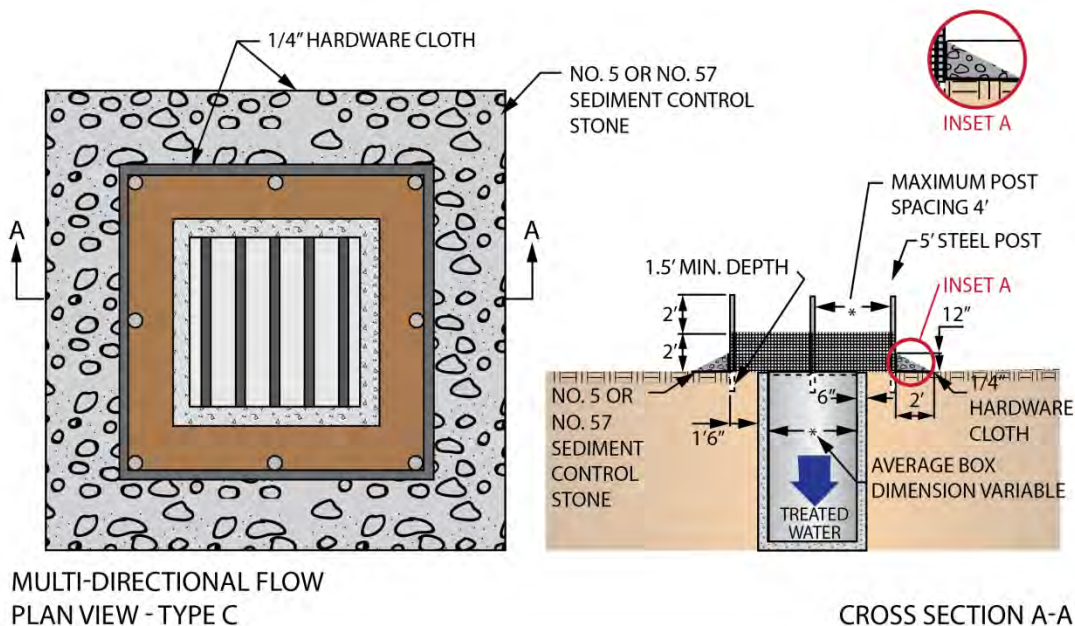

## 4.6.1 Rock Inlet Sediment Trap - Types A, B and C (1632.01, 1632.02, 1632.03)

A, B, C 

### Material Specifications

#### Type A

Structural Stone	<ul style="list-style-type: none"> <li>• Use Class B structural stone.</li> <li>• Meet the requirements of Section 1042 of Standard Specifications for Stone for Erosion Control, Class B.</li> </ul>
Sediment Control Stone	<ul style="list-style-type: none"> <li>• Use No. 5 or No. 57 stone.</li> <li>• Meet the requirements of Section 1005 of the Standard Specifications for stone sizes.</li> </ul>

#### Type B

Structural Stone	<ul style="list-style-type: none"> <li>• Use Class A structural stone.</li> <li>• Meet the requirements of Section 1042 of the Standard Specifications for Stone for Erosion Control, Class A.</li> </ul>
Sediment Control Stone	<ul style="list-style-type: none"> <li>• Use No. 5 or No. 57 stone.</li> <li>• Meet the requirements of Section 1005 of the Standard Specifications for stone sizes.</li> </ul>

#### Type C

Hardware Cloth	<ul style="list-style-type: none"> <li>• Use a wire mesh with ¼-inch openings.</li> <li>• Use 24-gauge wire, at a minimum.</li> <li>• Use a minimum width of 24 inches.</li> <li>• Meet the requirements of Section 1632-2 of the Standard Specifications.</li> </ul>
Steel Posts	<ul style="list-style-type: none"> <li>• Use a minimum of 5-foot long posts.</li> <li>• Use 1 ³⁄₈-inches wide posts on the face parallel to the hardware cloth.</li> <li>• Use self-fastener angle steel type posts.</li> <li>• Meet the requirements of Section 1632-2(A) of the Standard Specifications.</li> </ul>
Staples	<ul style="list-style-type: none"> <li>• Use No. 9 wire staples with at least 1 ½-inches length or another approved attachment device.</li> </ul>
Sediment Control Stone	<ul style="list-style-type: none"> <li>• Use No. 5 or No. 57 stone.</li> <li>• Meet the requirements of Section 1005 of the Standard Specifications for stone sizes.</li> </ul>

## 4.6.1 Rock Inlet Sediment Trap - Types A, B and C (1632.01, 1632.02, 1632.03)

A, B, C 

### Construction Specifications

#### Type A

<b>Spacing</b>	<ul style="list-style-type: none"> <li>1.5 feet of space required from the inside edge of the stone dam to the edge of the inlet</li> <li>Top of berm should be a minimum of 1-foot below the shoulder or any diversion point</li> </ul>
<b>Sediment Control Stone</b>	<ul style="list-style-type: none"> <li>No. 5 or No. 57 stone to be installed on the outer face of the stone dam in a layer 1-foot thick</li> </ul>
<b>Structural Stone</b>	<ul style="list-style-type: none"> <li>Class B stone installed in a doughnut-shaped ring around the inlet</li> <li>Installed with a 1.5-foot wide berm on the top and a minimum height of 2 feet</li> </ul>

Place the structural stone, Class B, around the outside perimeter of the inlet with approximately 2:1 side slopes and plate the upstream side with sediment control stone.

#### Type B

<b>Berm</b>	<ul style="list-style-type: none"> <li>1.5 feet of space required from the inside edge of the stone dam to the edge of the inlet</li> <li>Top of berm should be a minimum of 1-foot below the shoulder or any diversion point</li> </ul>
<b>Sediment Control Stone</b>	<ul style="list-style-type: none"> <li>No. 5 or No. 57 stone to be installed on the outer face of the stone dam in a layer 1-foot thick</li> </ul>
<b>Structural Stone</b>	<ul style="list-style-type: none"> <li>Class A stone installed in a doughnut-shaped ring around the inlet</li> <li>Installed with a 1-foot wide berm on the top and a height of 1.5 feet</li> </ul>

Place the structural stone, Class A, around the outside perimeter of the inlet with approximately 2:1 side slopes and plate the upstream side with sediment control stone.

## 4.6.1 Rock Inlet Sediment Trap - Types A, B and C (1632.01, 1632.02, 1632.03)

A, B, C 

### Type C

<b>Hardware Cloth</b>	<ul style="list-style-type: none"> <li>Installed at a height of 2 feet</li> <li>Placed under the sediment control stone</li> <li>1.5 feet of space required from the inside edge of the hardware cloth to the edge of the inlet</li> <li>Top of hardware cloth to be installed a minimum of 1-foot below the shoulder or any diversion point</li> </ul>
<b>Posts</b>	<ul style="list-style-type: none"> <li>Made of steel or other approved material</li> <li>Installed a minimum of 1.5-feet deep</li> <li>Installed with a maximum spacing of 4 feet</li> </ul>
<b>Sediment Control Stone</b>	<ul style="list-style-type: none"> <li>Installed on the outer face of the hardware cloth to a height of 1 foot and a width of 2 feet</li> </ul>

Construct rock inlet devices as shown on plans and at other locations as directed. Attach hardware cloth to posts with wire staple or other acceptable methods.

### Technician's Checklist

- Verify the proper type of rock inlet sediment trap is used.
- Maintain the device during the drainage structure construction.
- Keep the sediment stone clean and free of debris.
- Check to make sure that water is not impounded by a clogged device or flowing into travel lanes.
- Remove RISTs as the project nears completion or as directed.
- Dress the area to blend with existing contours, and seed and mulch the area.

**A clogged RIST can quickly impound water. The device should be free of debris and water should flow through, not around, the device in order to function properly.**

### Measurement & Payment

Pay Items Type A	Pay Units
Stone for Erosion Control, Class B	Ton
Sediment Control Stone	Ton
Silt Excavation	Cubic Yard

## 4.6.1 Rock Inlet Sediment Trap - Types A, B and C (1632.01, 1632.02, 1632.03)

A, B, C 

Pay Items Type B	Pay Units
Stone for Erosion Control, Class A	Ton
Sediment Control Stone	Ton
Silt Excavation	Cubic Yard

Pay Items Type C	Pay Units
¼-inch Hardware Cloth	Linear Foot
Sediment Control Stone	Ton
Silt Excavation	Cubic Yard

### Maintenance

- Inspect the device after each significant rainfall event for damage, sediment accumulation and proper function.
- Remove sediment from the device when accumulations reach one-half the height of the sediment control stone.
- Replace or clean the sediment control stone as needed to allow water to drain through the device between rainfall events.
- Rebuild and/or repair the device when it is damaged.
- If the device is to remain after project completion, it should be clean and in proper shape at the time of final inspection. If it is removed, all accumulated silt should be removed to keep it from entering the drainage system.

### Typical Problems

- Sediment accumulations are not removed in a timely fashion, causing sediment to be released into the storm drain system.
- Sediment control stone is not cleaned and becomes clogged, preventing proper drainage.
- The device is not rebuilt or repaired when damaged by storms and equipment.
- The device is not built wide enough to prevent water from washing around the device. Water should always flow through or over the device, not around.

## 4.6.1 Rock Inlet Sediment Trap - Types A, B and C (1632.01, 1632.02, 1632.03)

A, B, C 

*This page is intentionally left blank.*

## 4.6.2 Rock Pipe Inlet Sediment Trap Types A and B (1635.01 & 1635.02)



### Practical Tips

- Water should flow through the stone and not around the device.
- To function properly, the device needs to be clear of debris.

### Definition

Rock Pipe Inlet Sediment Traps (PIST) are horseshoe-shaped devices with built-in sediment storage areas that are placed around the outside perimeter of pipe inlets to provide sediment containment and protection for the water flowing to the pipe inlet. There are two different types of Rock Pipe Inlet Sediment Traps: Types A and B.

### Areas of Use

#### Rock Pipe Inlet Sediment Trap - Type A (PIST-A)

- At pipe inlets no larger than 36 inches in diameter where flow is received from several directions
- At least 30 feet from a vehicular travel lane in order to prevent a safety hazard in order to provide a clear recovery zone for motorists
- In areas where a BMP can be cleaned and maintained on a regular basis

#### Rock Pipe Inlet Sediment Trap - Type B (PIST-B)

- At pipe inlets no larger than 24 inches in diameter where flow is received from several directions
- At locations where a PIST-A would be unsafe due to adjacent traffic
- In areas where a BMP can be cleaned and maintained on a regular basis

Rock PISTs reduce water velocity and provide sediment storage.

## 4.6.2 Rock Pipe Inlet Sediment Trap Types A and B (1635.01 & 1635.02)



### Design Criteria

#### Type A

- The drainage area should not exceed 5 acres.
- The sediment basin should provide a storage volume of 3,600 cubic feet per acre of disturbed area and a surface area of 435 square feet per cfs of  $Q_{10}$  or  $Q_{25}$  peak inflow.
- The stone dam should be a minimum of 18 inches high.
- The top of the PIST-A shall be a minimum of 1 foot below the top of the fill over the pipe.
- To provide additional storage volume, additional erosion and sediment control measures may be installed up or down gradient to meet the volume requirements.
- Because of the larger size of the Class B stone, the PIST-A should be placed at locations that will not create a safety hazard to traffic.

**Do NOT place PIST-A at outlets with greater than 1 acre of drainage area.**

#### Type B

- The drainage area should not exceed 1 acre.
- The sediment trap should provide a storage volume of 3,600 cubic feet per acre of disturbed area and a surface area of 435 square feet per cfs of  $Q_{10}$  or  $Q_{25}$  peak inflow.
- The stone dam should be a minimum of 18 inches high.
- The top shall be a minimum of 1 foot below the top of the fill over the pipe.
- Some of the required volume may be provided by up gradient or down gradient controls.

If required, a sediment storage pit may be designed for both Types A and B following the same design guidelines for a Silt Basin - Type B.

# 4.6.2 Rock Pipe Inlet Sediment Trap Types A and B (1635.01 & 1635.02)

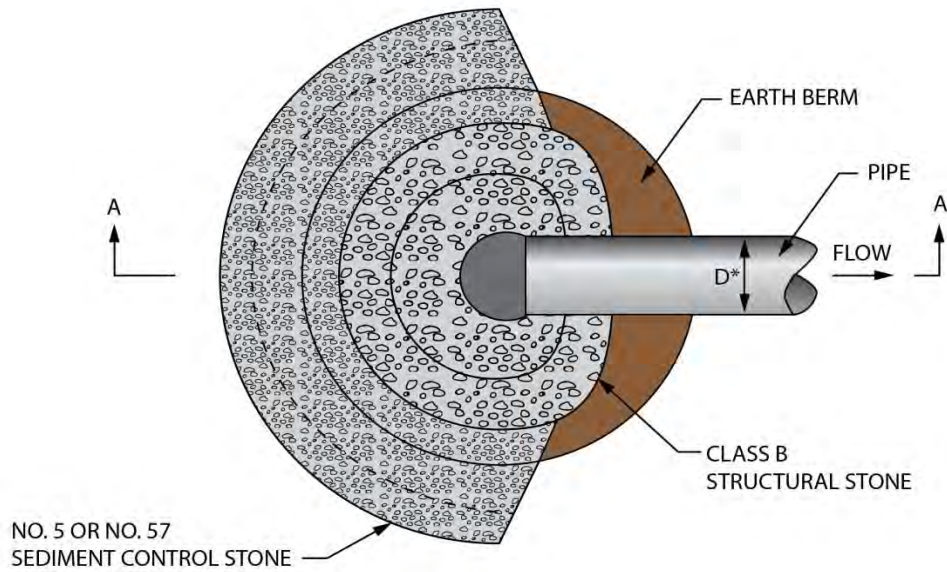

PLAN VIEW - TYPE A (NOT TO SCALE)

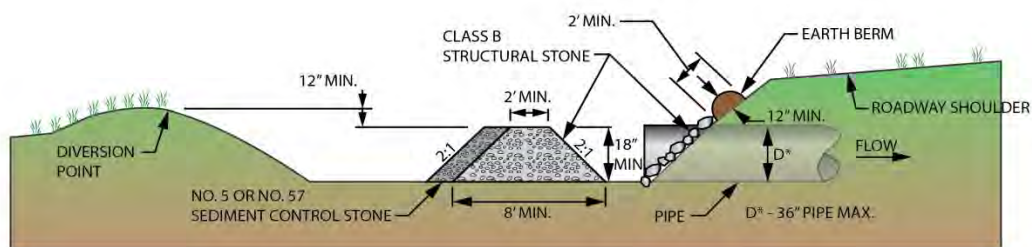

CROSS SECTION A-A - TYPE A (NOT TO SCALE)

# 4.6.2 Rock Pipe Inlet Sediment Trap Types A and B (1635.01 & 1635.02)

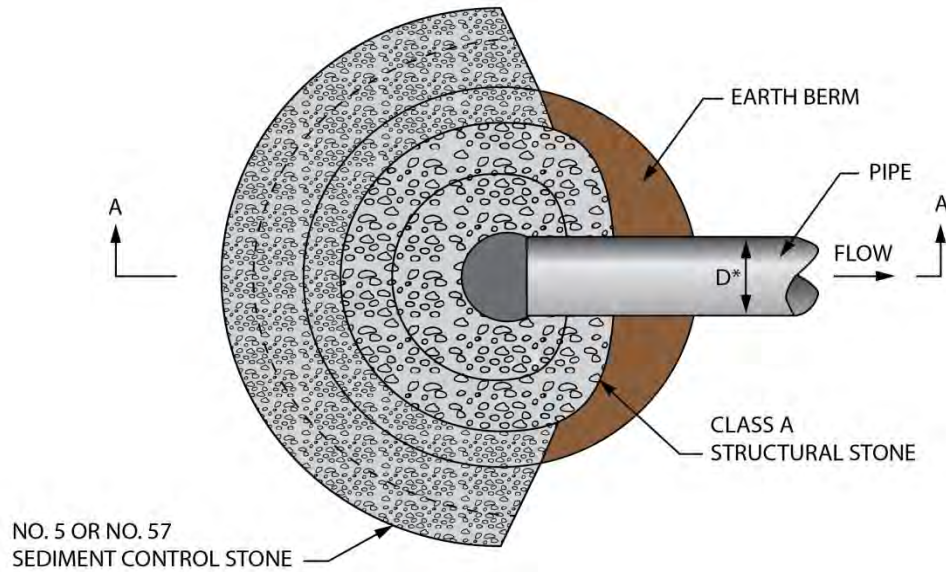

PLAN VIEW - TYPE B (NOT TO SCALE)

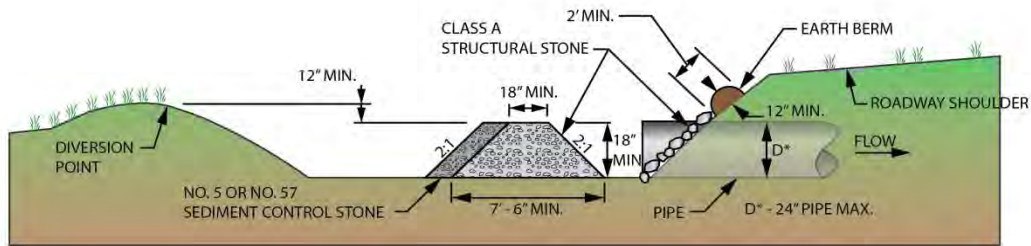

CROSS SECTION A-A - TYPE B (NOT TO SCALE)

## 4.6.2 Rock Pipe Inlet Sediment Trap Types A and B (1635.01 & 1635.02)



### Material Specifications

#### Type A

Structural Stone	<ul style="list-style-type: none"> <li>Use Class B structural stone.</li> <li>Meet the requirements of Section 1042 of Standard Specifications for Stone for Erosion Control, Class B.</li> </ul>
Sediment Control Stone	<ul style="list-style-type: none"> <li>Use No. 5 or No. 57 stone.</li> <li>Meet the requirements of section 1005 of the Standard Specifications for stone sizes.</li> </ul>

#### Type B

Structural Stone	<ul style="list-style-type: none"> <li>Use Class A structural stone.</li> <li>Meet the requirements of Section 1042 of the Standard Specifications for Stone for Erosion Control, Class A.</li> </ul>
Sediment Control Stone	<ul style="list-style-type: none"> <li>Use No. 5 or No. 57 stone.</li> <li>Meet the requirements of Section 1005 of the Standard Specifications for stone sizes.</li> </ul>

### Construction Specifications

#### Type A

Berm	<ul style="list-style-type: none"> <li>Top of the berm should be a minimum of 12 inches below the roadway shoulder or any diversion point</li> <li>Side slopes should be no steeper than 2:1</li> <li>Berm should have a minimum height of 18 inches</li> </ul>
Sediment Control Stone	<ul style="list-style-type: none"> <li>No. 5 or No. 57 stone should be installed on the outer face of the stone dam in a layer 1-foot thick</li> </ul>
Structural Stone	<ul style="list-style-type: none"> <li>Class B stone should be installed in a horseshoe-shaped ring around the inlet</li> <li>Stone should be installed with a berm at the top that is 2-feet wide</li> <li>Stone should have an 8-foot minimum base width</li> </ul>

## 4.6.2 Rock Pipe Inlet Sediment Trap Types A and B (1635.01 & 1635.02)



### Type B

Berm	<ul style="list-style-type: none"> <li>Top of the berm should be a minimum of 12 inches below the shoulder or any diversion point</li> <li>Side slopes should be no steeper than 2:1</li> <li>Berm should have a minimum height of 18 inches</li> </ul>
Sediment Control Stone	<ul style="list-style-type: none"> <li>No. 5 or No. 57 stone should be installed on the outer face of the stone dam in a layer 1-foot thick</li> </ul>
Structural Stone	<ul style="list-style-type: none"> <li>Class A stone should be installed in a doughnut-shaped ring around the inlet</li> <li>Installed with a berm on the top that is 18-inches wide.</li> <li>Stone should have a minimum base width of 7.5 feet.</li> </ul>

### Technician's Checklist

- Match the trap type and the pipe size requirements for each type of device.
- The purpose of the open area in front of the pipe where there is no stone is to allow clean out of the device when necessary. Construct the device so the open area is large enough that clean out can be done by equipment on the project.
- Clean sediment from the upgradient side of the device as necessary so the device will function properly.
- Maintain a sufficient area between the pipe and the trap to allow for cleaning.
- On both Type A and B PISTs, tie the stone into slopes to prevent water from bypassing the device. Construct the earth berm on the slope above the pipe inlet between the stone and tie in to the slope
- Carry the stone stabilization on the slope to a height above the top of the pipe and at least as high as the top of the trap. Water should flow over the trap before it will wash between the trap stone and slope. Water should rise and fall along the slope and not flow along it.
- Remove Rock Pipe Inlet Sediment Traps as the project nears completion or as directed.
- Dress the area to blend with existing contours, and seed and mulch the area.

### Measurement & Payment

Pay Items Type A	Pay Units
Stone for Erosion Control, Class B	Ton
Sediment Control Stone	Ton
Silt Excavation	Cubic Yard

## 4.6.2 Rock Pipe Inlet Sediment Trap Types A and B (1635.01 & 1635.02)



Pay Items Type B	Pay Units
Stone for Erosion Control, Class A	Ton
Sediment Control Stone	Ton
Silt Excavation	Cubic Yard

### Maintenance

- Inspect the device after each significant rainfall event for damage, sediment accumulation and proper function.
- Remove sediment from the device when accumulations reach one-half the height of the basin area formed by the device.
- Replace the sediment control stone as needed to allow water to drain through the device between rainfall events.
- Clean out the device when it is clogged with debris.
- If the device is to remain on the project at the completion of construction activities, the device should be clean and in proper shape at the time of final inspection. If it is removed, all accumulated silt should be removed and the area seeded.

### Typical Problems

- Silt accumulations are not removed causing silt to enter the pipe.
- The structure is not rebuilt when damaged by storms and equipment.
- The stone is not cleaned or replaced when clogged.
- The stone is not tied into slopes.

# 4.7

## Section

### Sediment Containment

Riser Basin	4.7.1
Silt Basin - Type B	4.7.2
Skimmer Basin	4.7.3
Tiered Skimmer Basin	4.7.4
Infiltration Basin with Baffles	4.7.5
Temporary Rock Sediment Dam - Type A	4.7.6
Temporary Rock Sediment Dam – Type B	4.7.7
Coir Fiber Baffle	4.7.8
Earthen Dam with Skimmer	4.7.9
Stormwater Basin with Skimmer	4.7.10

Sediment containment must be considered early in the planning phase. Some of the devices in this section are used to detain stormwater runoff so that solids can settle and stormwater may then be discharged. Other devices in this section are used at outlets or stream crossings to trap sediment before the stormwater leaves a project site.

Use the following BMPs when considering measures to provide sediment containment: Riser Basin, Silt Basin - Type B, Skimmer Basin, Tiered Skimmer Basin, Infiltration Basin, Temporary Rock Sediment Dam - Types A and B, Earthen Dam with Skimmer, and Stormwater Basin with Skimmer. Coir Fiber Baffles should be planned for each sediment containment measure as appropriate.

## 4.7.1 Riser Basin (1630.01)



### Practical Tips

- Place the riser basin outside of the roadway footprint to allow use for the duration of the project.
- Provide access for equipment to remove and dispose of sediment accumulations.

### Definition

A riser basin is an earthen embankment and excavated area used to capture sediment. A riser basin prevents sediment from leaving the construction site and entering off-site jurisdictional areas or adjacent properties. A series of coir fiber baffles are used in the riser basin. A non-perforated riser pipe is used in conjunction with a skimmer for controlled dewatering, which allows sediment to settle in the basin. An emergency overflow spillway is designed to release runoff if the riser capacity is exceeded.

### Areas of Use

- In large drainage areas where other erosion and sediment control devices will not be adequate due to the volume of runoff

**Consider riser basins when the drainage area exceeds the 10-acre threshold and the watershed cannot be portioned out with smaller basins due to site constraints.**

## 4.7.1 Riser Basin (1630.01)

### Design Criteria

- The drainage area should not exceed 100 acres.
- The basin should be located in an area where it can be accessed and maintained for the life of the basin.
- The minimum surface area and minimum volume are measured below the top of the principal spillway (top of the riser).
- The minimum volume is 1,800 cubic feet per acre of drainage area.
- The minimum surface area is 435 square feet per cfs of  $Q_{10}$  or  $Q_{25}$  peak inflow.
- The minimum length to width ratio is 2:1 with a maximum of 6:1.
- The minimum depth is 2 feet.
- The dewatering mechanism should be a skimmer or flashboard riser.
- The minimum dewatering time is 48 hours.
- The principal spillway (riser/barrel pipe) must be able to convey the peak runoff from the 2-year storm with the water's surface at the crest elevation of the overflow spillway.
- The overflow spillway must convey the peak runoff from the design storm with a minimum of 1 foot of freeboard.
- A minimum of 3 coir fiber baffles shall be installed in the riser basin.
- The basin design life should be 3 years.

**When the surface area and/or sediment storage requirement for a basin cannot be achieved, design the basin to the maximum practical length and width. Also use flocculant with devices (wattle, TRSC-A with matting) upgradient of the basin.**

# 4.7.1 Riser Basin (1630.01)

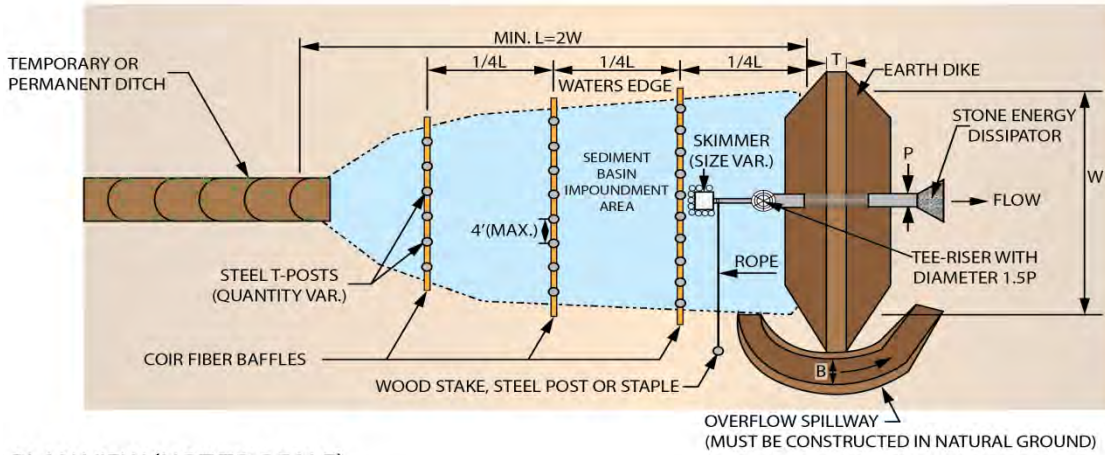

PLAN VIEW (NOT TO SCALE)

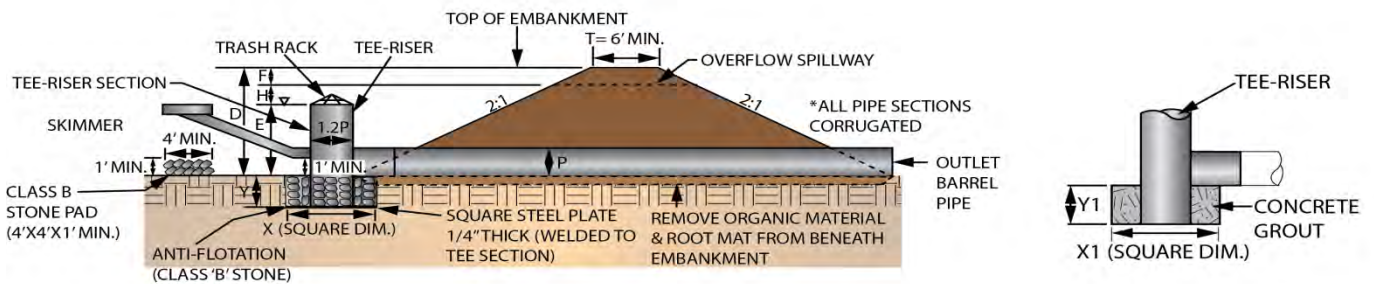

PROFILE VIEW (NOT TO SCALE)

ALTERNATE ANTI-FLOTATION METHOD

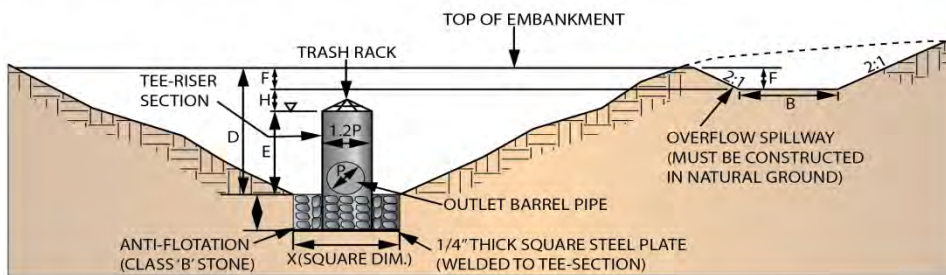

SECTIONAL VIEW (NOT TO SCALE)

#4 BAR SUGGESTED LAYOUT SHOWN:  
HOWEVER OTHER LAYOUTS MAY BE  
USED PROVIDED OPENINGS ARE 64" ±  
SQ. IN AREA

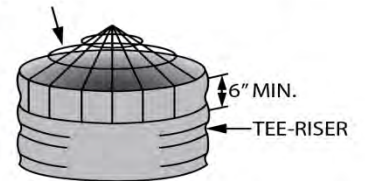

TRASH RACK DETAIL

## 4.7.1 Riser Basin (1630.01)

### Material Specifications

- The embankment should be constructed of suitable fill material.
- Stone used in the anti-flotation, stone pad and overflow spillway should meet the requirements of Section 1042 of the Standard Specifications for Plain Rip Rap, Class \_\_\_\_.
- The riser and barrel should be corrugated metal pipe, and in accordance with Section 310 of the Standard Specifications.
- The skimmer should meet the requirements of the Erosion and Sediment Control plans.
- Baffles should meet the requirements of Section 1640-2 of the Standard Specifications.

### Construction Specifications

<b>Riser Basin</b>	<ul style="list-style-type: none"> <li>• Stabilize the embankment, interior slopes and surrounding areas with permanent vegetation following installation.</li> <li>• Install a minimum of 3 coir fiber baffles in the basin with a spacing of ¼ the basin length and in accordance with Section 1640 of the Standard Specifications.</li> <li>• Restrict the maximum dam height to 25 feet. Dams exceeding 25 feet in height and impounding 50 acre-feet or more become subject to the NC Dam Safety Act. (Height is measured from the top of the dam to the lowest point on the downstream toe. Volume is measured at the top of the dam.)</li> <li>• Attach the skimmer to the riser 1 foot above the bottom of the basin.</li> <li>• Restrict the minimum barrel size to 15 inches for corrugated metal pipe to reduce the potential for failure due to debris or blockages.</li> <li>• Construct the diameter of the riser to be 1.2 times that of the barrel pipe diameter.</li> <li>• Armor the overflow spillway with Class B stone as specified on the plans.</li> <li>• Use Class B stone for anti-flotation for the riser and barrel pipes.</li> <li>• Construct the earth dike along one or more sides, if needed. Excavation may be required to provide a minimum surface area and/or a minimum storage volume.</li> <li>• Construct the dike of material suitable for and meeting roadway embankment specifications.</li> <li>• To facilitate the determination of the maintenance cleanout requirement, place a marker in the basin indicating the 50% volume level.</li> <li>• Provide a stone energy dissipator pad at the outlet of the riser barrel in accordance with Roadway Standard Drawing No. 876.02 for Pipe Outlet Without Ditch.</li> <li>• Seed and place matting for erosion control on all interior and exterior slopes of the basin. Refer to the Rolled Erosion Control Products Section 4.4 for matting requirements.</li> </ul>
--------------------	--------------------------------------------------------------------------------------------------------------------------------------------------------------------------------------------------------------------------------------------------------------------------------------------------------------------------------------------------------------------------------------------------------------------------------------------------------------------------------------------------------------------------------------------------------------------------------------------------------------------------------------------------------------------------------------------------------------------------------------------------------------------------------------------------------------------------------------------------------------------------------------------------------------------------------------------------------------------------------------------------------------------------------------------------------------------------------------------------------------------------------------------------------------------------------------------------------------------------------------------------------------------------------------------------------------------------------------------------------------------------------------------------------------------------------------------------------------------------------------------------------------------------------------------------------------------------------------------------------------------------------------------------------------------------------------------------------------------------------------------------------------------------------------------------------------------------------------------------------------------------------------------------------------------------------------------------------------------

## 4.7.1 Riser Basin (1630.01)

It is important that the anti-flotation device is installed properly before any water flows into the basin. The riser, stone and skimmer need to be located for easy access. Construct overflow spillways to limit erosion, especially in newly constructed dikes. Fabric and stone may be required to stabilize the overflow spillway if vegetation is not established. The dike and overflow spillway must be stabilized as soon as possible.

### Standard Basin Dimensions

P	H	T (MIN)	D*	E	F	B (MIN)	X (MIN)	Y (MIN)	X <sub>1</sub> (MIN)	Y <sub>1</sub> (MIN)
IN	FT	FT	FT	FT	FT	FT	FT	FT	FT	FT
15	1.0	6.0	6.0	4.0	1.0	3.0	2.7	1.0	2.5	1.0
18	1.0	6.0	6.5	4.5	1.0	4.0	3.5	1.0	3.2	1.0
24	1.0	6.0	8.0	6.0	1.0	8.0	5.5	1.0	5.0	1.0
30	1.0	6.0	9.5	7.0	1.5	8.0	7.6	1.0	6.9	1.0

\* Shall not exceed 12'. Refer to detail drawing.

### Technician's Checklist

- Do not change the shape or size of the basin without consulting the Engineer.
- Verify the area where the basin is to be placed is permitted for the activity.
- Verify the area where the basin is proposed will be suitable for the device. Consider soil type, water table and accessibility.
- Maintain access to the basin at all times, so that it can be cleaned as needed.
- Remove the basin at the end of the project, if required.
- Meet the requirements of the plans or Standard Drawings for the pipe, riser, anti-flotation device, sediment control stone and trash rack.
- Install the Class B stone pad beneath the skimmer location to prevent the skimmer from being buried in and clogged with sediment and debris if the water elevation becomes low.
- Compact the dam with good soil so that it can withstand the volume of water.
- Construct the overflow spillway on natural ground and stabilize immediately per plans.
- Seed and mulch the dam.

**It is very important to obtain a positive seal around the pipe going through the basin's dike to the outfall. This is a weak area and will need special attention to eliminate leaks and blowouts.**

## 4.7.1 Riser Basin (1630.01)

### Measurement & Payment

Pay Items	Pay Units
Silt Excavation	Cubic Yard
Riprap, Class _____	Ton
_____" x _____" x _____" C.S. Pipe Tee-Riser, _____" Thick	Each
_____" CMP Outlet Pipe	Linear Foot
_____" Skimmer	Each
Seed for Temporary Seeding	Pound
Fertilizer for Temporary Seeding	Ton
Coir Fiber Baffle	Linear Foot

### Maintenance

- Inspect the basin and riser on a regular basis and after every significant rainfall event (1/2 inch or greater).
- Inspect the riser for proper operation. Remove debris from around the riser or the trash rack.
- Check the skimmer for proper functioning and to verify that it is not clogged with sediment.
- Make sure the vent pipe on the skimmer is turned upright.
- Inspect the barrel for seepage around the pipe at the outlet.
- Inspect the embankment, baffles, overflow spillway and outlet for erosion damage.
- At a minimum, remove sediment when the basin volume reaches 50% of the total storage volume and as needed.

### Typical Problems

- The spillway and/or embankment eroded due to inadequate vegetation or side slopes being too steep.
- The elevations of the riser pipe and overflow spillway are too high in relation to the top of the dam.
- The riser has no anti-flotation measure.
- The skimmer becomes clogged with sediment or debris.
- The skimmer overturns and the vent pipe is facing the bottom of the basin and is submerged in water.
- The stone pad underneath the skimmer device gets covered with sediment and the skimmer becomes embedded in sediment at the bottom of the basin.
- The outlet protection on the barrel pipe is inadequate.
- No access is provided for cleanout.
- Material is stockpiled next to the basin without adequate erosion and sediment control measures.
- Equipment is unable to reach into the middle of the basin for silt removal.
- Safety is a concern for humans and animals.

## 4.7.2 Silt Basin - Type B (1630.02)



### Practical Tips

- Basins at drainage outlets or adjacent to drainage inlets should have baffles.
- Basins must be cleaned out in order to maintain their effectiveness.

### Definition

A Silt Basin - Type B is a temporary basin constructed to settle out and collect sediment flowing through a drainage way. The silt basin is built at the base of the ditch with its length being at least 2 times the width of the basin. The Type B basin is generally built in conjunction with temporary rock silt checks, stone inlet protection and other devices that control or slow down water flow.

### Areas of Use

- In conjunction with temporary rock silt checks and other devices used in drainage ditches
- Adjacent to drainage inlets such as catch basins and drop inlets
- At drainage outlets in conjunction with coir fiber baffles and stone devices
- At pipe outlets, changes in grade, in medians and lateral ditches.

**Consider the visibility of locations and safety concerns when determining the basin geometry and placement.**

## 4.7.2 Silt Basin - Type B (1630.02)



### Design Criteria

- The drainage area should be 3 acres or less.
- The basin length to width ratio should be at least 2:1 but should not exceed 6:1.
- The basin depth should be at least 2 feet.
- The minimum volume should be 1,800 cubic feet per acre of disturbed area when used adjacent to drainage structures and 3,600 cubic feet per acre when used at drainage outlets in conjunction with stone devices.
- The minimum surface area should be 325 square feet per cfs of  $Q_{10}$  or  $Q_{25}$  peak inflow when used adjacent to drainage structures, and 435 square feet per cfs when used at drainage outlets in conjunction with stone devices.
- A minimum of 3 baffles should be installed in the silt basins at drainage outlet locations with a spacing of  $\frac{1}{4}$  the basin length.
- For silt basins less than 20 feet in length, 2 baffles shall be installed with a spacing of  $\frac{1}{3}$  the basin length.
- If silt basin is not located at a drainage outlet, baffles are not required.

**Unless permitted, don't place silt basins in riparian buffer zones or wetlands. Do not place in live streams.**

**Avoid placing silt basins close to homes or businesses and in areas of human safety concerns.**

## 4.7.2 Silt Basin - Type B (1630.02)

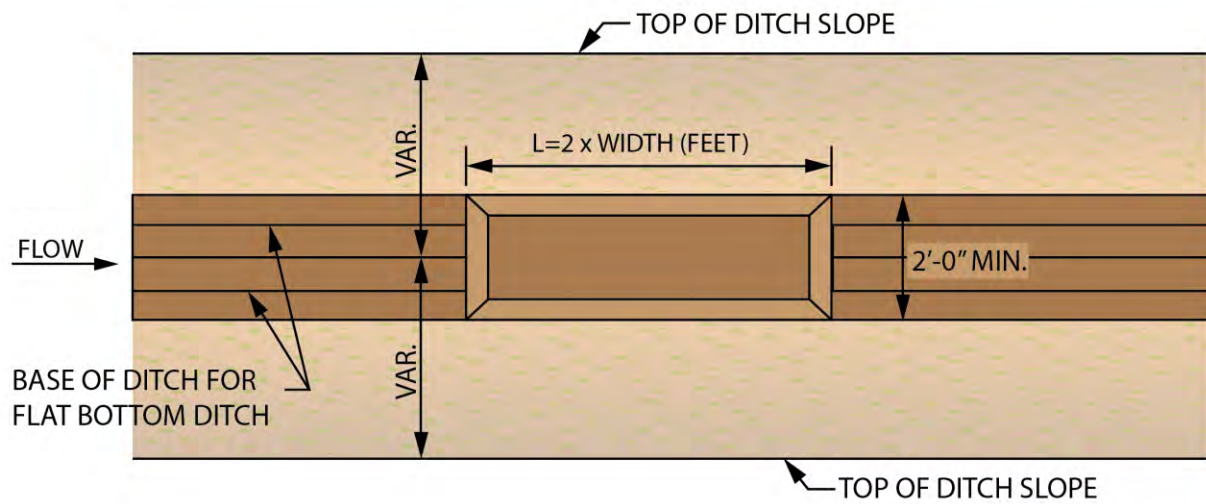

PLAN VIEW

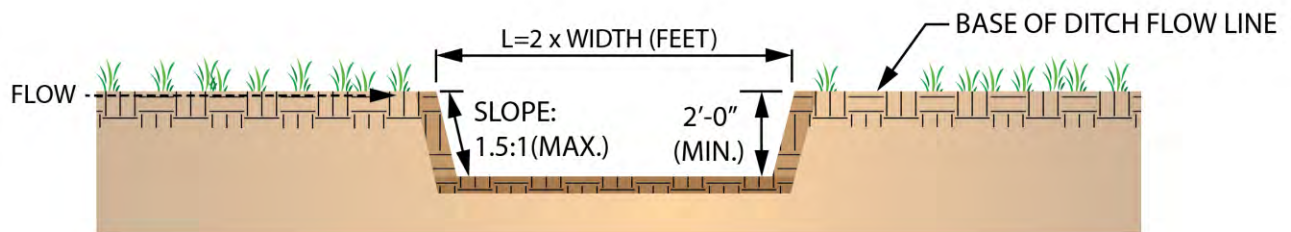

PROFILE VIEW

## 4.7.2 Silt Basin - Type B (1630.02)



### Material Specifications

- Coir fiber baffles should meet the requirements of Section 1640-2 of the Standard Specifications.
- Fill material should be considered unclassified earth in accordance with Section 225 of the Standard Specifications or in Section 230 for Borrow Excavation, depending on the source of the material used to fill the basin.

### Construction Specifications

<b>Silt Basin - Type B</b>	<ul style="list-style-type: none"> <li>• Construct basins with an excavated depth of at least 2 feet from the base of the ditch flow line.</li> <li>• Construct basins with non-vertical side slopes and not greater than 1.5:1 slope.</li> <li>• For silt basins at drainage outlets, install a minimum of 3 coir fiber baffles in the basin, with a spacing of <math>\frac{1}{4}</math> the basin length and in accordance with Section 1640 of the Standard Specifications.</li> <li>• Install a minimum of 2 coir fiber baffles in basins with less than 20 feet of length at a spacing of <math>\frac{1}{3}</math> the basin length.</li> </ul>
----------------------------	------------------------------------------------------------------------------------------------------------------------------------------------------------------------------------------------------------------------------------------------------------------------------------------------------------------------------------------------------------------------------------------------------------------------------------------------------------------------------------------------------------------------------------------------------------------------------------------------------------------------------------------------------

### Technician's Checklist

- Review permits to determine if the silt excavation is permitted as shown in the Erosion and Sediment Control Plans.
- Install the devices as shown in the Roadway Standard Drawings. Water should flow through the device, not around it.
- Monitor silt basins closely and clean out the basins on a regular basis until grass is established along the ditch line and sedimentation is no longer an issue.
- Perform an inspection of all erosion and sediment control features at least weekly and after each significant rainfall.
- Notify the Engineer when erosion and sediment control devices are not installed or maintained by the abatement date shown on the erosion and sediment control inspection report.
- Clean silt detention devices when they are no more than 50% full.
- Remove devices as appropriate for the next phase of construction or when the final stand of vegetation has been established.

**The purpose of silt detention devices is to provide a surface area large enough to slow the velocity of the runoff and allow for settlement of silt.**

## 4.7.2 Silt Basin - Type B (1630.02)



### Measurement & Payment

#### Pay Items

#### Pay Units

Silt Excavation

Cubic Yard

Coir Fiber Baffle

Linear Foot

### Maintenance

- Inspect the basin on a regular basis and after every significant rainfall event (1/2 inch or greater).
- At a minimum, clean out the basins when they are approximately one-half full.
- Check for damage to coir fiber baffles and repair and/or replace the baffles.

### Typical Problems

- The basins are not constructed to the dimensions specified on the plans and result in inadequate basin capacities.
- The basins are constructed with vertical side slopes, increasing erosion of side slopes and sediment in basins.
- Silt accumulations are not removed when needed.
- Basins built in ditch lines in sandy soils may cause sloughing of slopes.
- Basins are too deep causing erosion at the inlet end and presenting safety problems.
- If water remains in the basins and saturates the area, it may indicate problems with the grade.
- Water flows under or around the coir fiber baffles and the settling time decreases instead of increasing.

## 4.7.3 Skimmer Basin



### Definition

A skimmer basin is a temporary basin with a trapezoidal spillway lined with geotextile and equipped with a floating skimmer for dewatering from the top of the water column. The skimmer basin is designed to dewater at a controlled rate, which helps optimize efficiency of the device by maximizing sediment settling time and releasing the cleanest water from the top of the water column.

### Areas of Use

- At the outlet of large drainage areas that discharge into or near sensitive watersheds
- In areas near high quality waters, buffer zones and/or Environmentally Sensitive Areas (ESA)
- In areas where drainage areas are too large for a basin with a standard rock weir

### Practical Tips

- Skimmer basins are more expensive than Temporary Rock Sediment Dams, Type B (TRSD-B), but have a smaller footprint.
- Skimmer basins are the recommended device at drainage outlets that drain directly to jurisdictional water bodies and buffer zones.

The skimmer orifice is designed to dewater the basin in 2 to 3 days per the NCDOT Basin Design design guidelines.

## 4.7.3 Skimmer Basin



### Design Criteria

- The drainage area should be 10 acres or less.
- The basin length-to-width ratio should be at least 2:1 but should not exceed 6:1.
- The basin depth should be at least 2 feet.
- The minimum volume should be 1,800 cubic feet per acre of disturbed area.
- The minimum surface area should be 325 square feet per cfs of  $Q_{10}$  or  $Q_{25}$  peak inflow.
- The dewatering time should be between 48 hours and 72 hours.
- The primary spillway should carry the peak runoff from the design storm with a minimum 1 foot of freeboard depth in the spillway.
- The primary spillway length (feet) should be determined by using  $Q/0.4$ , where  $Q$  is the flow rate (cfs) into the basin.
- The minimum primary spillway weir length should be 4 feet.
- A minimum of 3 coir fiber baffles should be installed in the skimmer basin with a spacing of  $\frac{1}{4}$  the basin length.
- For skimmer basins less than 20 feet in length, 2 baffles shall be installed with a spacing of  $\frac{1}{3}$  the basin length.
- NCDOT Basin Design Spreadsheet should be used to design the basin.  
[http://www.ncdot.gov/doh/operations/dp\\_chief\\_eng/roadside/soil\\_water/erosion\\_control/downloads.html](http://www.ncdot.gov/doh/operations/dp_chief_eng/roadside/soil_water/erosion_control/downloads.html)

## 4.7.3 Skimmer Basin

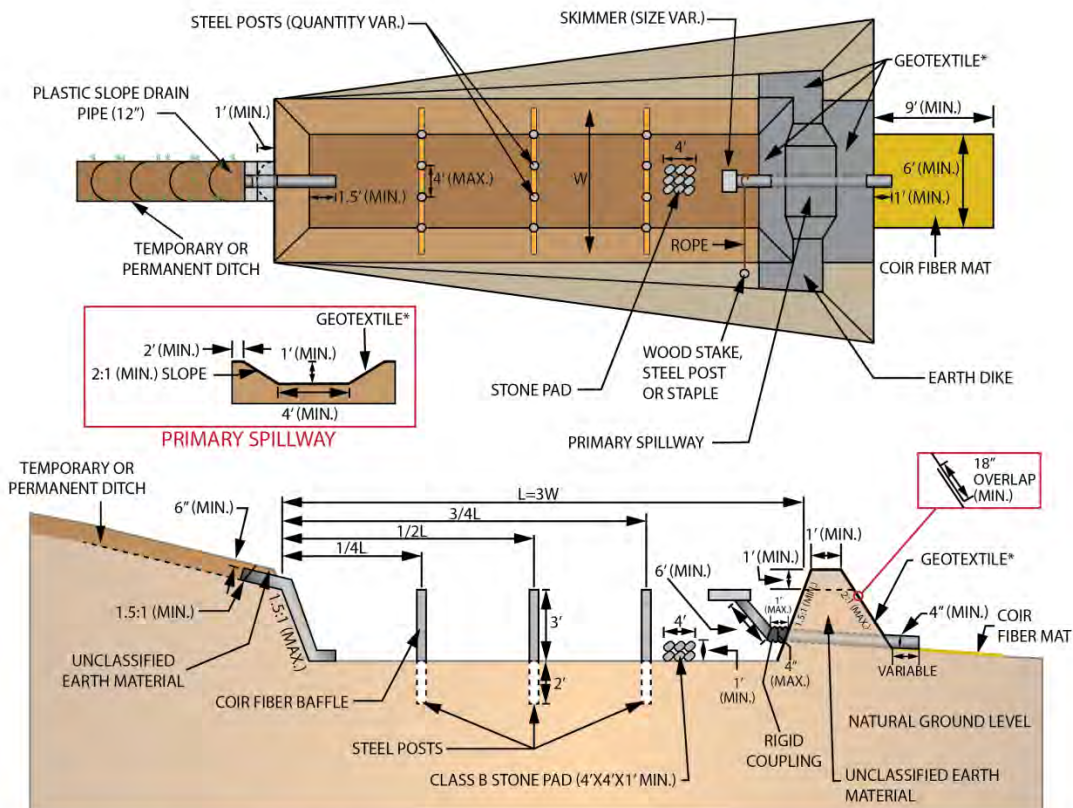

PLAN VIEW, CROSS SECTION AND PRIMARY SPILLWAY (NOT TO SCALE)

\* LOW PERMEABILITY GEOTEXTILE FOR EAST AREAS - DIVISIONS 1, 2, 3, 4 & 6.

PLACE A 6-INCH BAND OF SEALANT AROUND THE INTERIOR FACE OF THE OUTLET BARREL PIPE.

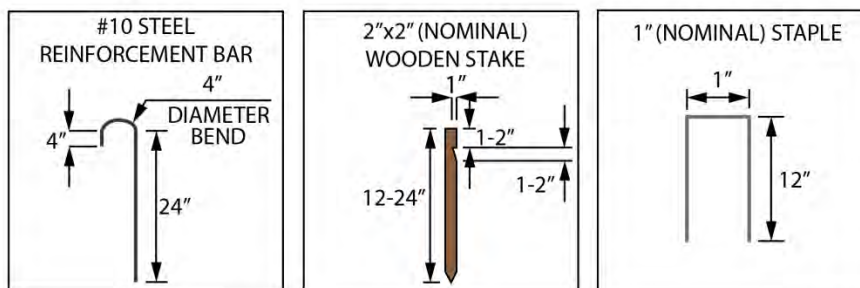

COIR FIBER MAT ANCHOR OPTIONS

## 4.7.3 Skimmer Basin



### Material Specifications

- The skimmer should meet the requirements of the Erosion and Sediment Control plan.
- Coir fiber baffles should meet the requirements of Section 1640-2 of the Standard Specifications.
- Coir fiber mat should meet the requirements of Section 1060-14 of the Standard Specifications.
- Permanent or temporary seed should meet the requirements of Section 1060-4 of the Standard Specifications.
- Fertilizer for temporary seed should meet the requirements of Section 1060-2 of the Standard Specifications.
- Matting for erosion control should meet the requirements of Section 1060-8 of the Standard Specifications.
- All embankment material should be considered unclassified earth.

The geotextile should meet the requirements of Section 1056 of the Standard Specifications for Type 4 Geotextile for Soil Stabilization. For eastern Divisions 1, 2, 3, 4, and 6, the geotextile for the spillway liner shall meet the following minimum properties for low permeability, woven polypropylene geotextiles:

Geotextile Property	Test Method	Value	Unit
Tensile Strength	ASTM D4632	315	lb
Tensile Elongation (Maximum)	ASTM D4632	15	%
Trapezoidal Tear	ASTM D4533	120	lb
CBR (California Bearing Ratio)	ASTM D6241	900	lb
Puncture			
UV Resistance (% retained at 500 hrs.)	ASTM D4355	70	US Std. Sieve
Apparent Opening Size (AOS)	ASTM D4751	40	%
Permittivity	ASTM D4491	0.05	sec <sup>-1</sup>
Water Flow Rate	ASTM D4491	4	gal/min/ft <sup>2</sup>

## 4.7.3 Skimmer Basin



### Construction Specifications

<b>Installation</b>	<ul style="list-style-type: none"> <li>Construct the basin according to the Erosion and Sediment Control plan with the basin surface free of obstructions, debris and pockets of low-density material.</li> <li>Assemble and install the skimmer as instructed by the manufacturer.</li> <li>Place a 6-inch band of sealant around the interior face of the outlet barrel pipe.</li> <li>Depending on the expected time period for which the skimmer basin is designed, permanently or temporarily seed all bare side slopes of the basin.</li> </ul>
<b>Dimensions</b>	<ul style="list-style-type: none"> <li>Limit the dam height to 5 feet.</li> <li>Install the skimmer a minimum of 1 foot from the bottom of the basin.</li> <li>The minimum basin width should be 3 times the depth of the basin. For a basin depth of 3 feet, the minimum basin width should be 9 feet.</li> </ul>
<b>Matting</b>	<ul style="list-style-type: none"> <li>Install coir fiber matting under the outlet of the skimmer with minimum dimensions of 9 feet long by 6 feet wide.</li> <li>Install matting for erosion control on exposed side slopes after seeding is completed.</li> </ul>
<b>Geotextile</b>	<ul style="list-style-type: none"> <li>Unroll the geotextile on the spillway in the direction of flow, with edges buried at least 6 inches deep. The geotextile should be one continuous piece of material or overlapped a minimum of 18 inches. For Divisions 1, 2, 3, 4, and 6 in the eastern part of the state, use a low permeability geotextile.</li> <li>Replace the plastic slope drain pipe at the inlet of the basin with geotextile as directed.</li> </ul>
<b>Baffles</b>	<ul style="list-style-type: none"> <li>Install 3 coir fiber baffles in the skimmer basin with a spacing of <math>\frac{1}{4}</math> the basin length.</li> <li>Install a minimum of 2 coir fiber baffles in basins with less than 20 feet of length at spacing of <math>\frac{1}{3}</math> the basin length.</li> </ul>
<b>Stone</b>	<ul style="list-style-type: none"> <li>Install a Class B stone pad (4 feet by 4 feet by 12 inches high) directly underneath the skimmer device.</li> </ul>
<b>Anchors</b>	<ul style="list-style-type: none"> <li>Anchor the coir fiber mat with wooden stakes, steel reinforcement rebar or metal staples.</li> <li>Anchor the geotextile with 6" staples at a maximum spacing of 3 ft.</li> </ul>
<b>Primary Spillway</b>	<ul style="list-style-type: none"> <li>Construct the primary spillway with a trapezoidal cross-section, with 2:1 side slopes, and a minimum base width of 4 feet.</li> </ul>

## 4.7.3 Skimmer Basin



### Technician's Checklist

- Do not change the shape or size of the basin without consulting with the Engineer.
- Verify the area where the basin is to be placed is permitted for the activity.
- Verify the area where the basin is proposed will be suitable for the device. Consider the soil type, water table and accessibility.
- Maintain access to the basin at all times so that it can be cleaned as needed.
- Remove the basin at the end of the project, if required.
- Meet the requirements of the plans or Standard Drawings for the pipe, earth dike, skimmer, spillway and baffles.
- Install the Class B stone pad beneath the skimmer location to prevent the skimmer from being buried in and clogged with sediment and debris if the water elevation becomes low.
- Compact the dam with clay soil so that it can withstand the volume of water.
- Seed and mat the remainder of interior and exterior slope areas not covered with geotextile.

### Measurement & Payment

Pay Items	Pay Units
Silt Excavation	Cubic Yard
Coir Fiber Mat	Square Yard
Geotextile for Drainage	Square Yard
Low Permeability Geotextile	Square Yard
__" Skimmer	Each
Riprap, Class __	Ton
Seed for Temporary Seeding	Pound
Fertilizer for Temporary Seeding	Ton
Matting for Erosion Control	Square Yard
Temporary Slope Drains	Linear Foot

## 4.7.3 Skimmer Basin



### Maintenance

- Inspect the basin on a regular basis and after every significant rainfall event (1/2 inch or greater).
- Clean out the basins when sediment accumulations reach approximately one-half the height of the first baffle.
- Check the skimmer to make sure that it is not clogged with sediment.
- Check the fabric lined spillway for damage.
- Check the coir fiber mat at the outlet of the skimmer to determine if a replacement is needed.
- During winter, support the skimmer at an angle such that water does not stand inside the barrel. This could result in the water freezing and plugging the skimmer.
- Repair seed and replace matting on the side slope areas that have eroded or have become damaged by equipment from silt cleanout.
- Remove sediment that may accumulate on the stone pad underneath the skimmer device.
- Inspect the baffles after each rain event for erosion damage and sediment accumulations.
- 

### Typical Problems

- Basins are not constructed to the dimensions specified on the plans and result in inadequate basin capacities.
- Silt accumulations are not removed when needed.
- Erosion occurs at the inlet end when the basin is too deep.
- The basin is too deep, therefore safety is a concern.
- The skimmer becomes clogged.
- The stone pad beneath the skimmer device becomes covered with sediment and the skimmer becomes embedded in the bottom of the basin.
- The geotextile for the primary spillway is not keyed in well, water washes underneath it, and the dam fails.
- Water flows under or around the coir fiber baffles and settling time decreases instead of increases.
- Equipment damages side slopes of the basin during silt cleanout.
- Erosion of the side slopes occur causing excess sediment to wash into the basin.

## 4.7.3 Skimmer Basin



*This page is intentionally left blank.*

## 4.7.4 Tiered Skimmer Basin



### Definition

A tiered skimmer basin is a series of temporary basins with trapezoidal spillways lined with geotextile. The lower basin is equipped with a floating skimmer for dewatering from the top of the water column. It is often used at the outlet of larger drainage areas that discharge into or near sensitive watersheds, where the elevation difference between the inlet and the outlet will be too large for just one skimmer basin. Tiered skimmer basins dewater into one another through geotextile-lined spillways into the next basin. The tiered skimmer basin is designed to dewater at a controlled rate with a step-pool approach, which helps maximize efficiency of the device by allowing a greater settling time for sediment and releasing the cleanest water from the top of the water column.

### Practical Tips

- Flocculant can be introduced at the slope drain inlets of the upper basins if other basins are installed down gradient.
- Linear configuration lends itself to roadway projects.

## 4.7.4 Tiered Skimmer Basin



### Areas of Use

- At outlets in larger drainage areas that discharge directly to jurisdictional waters
- In areas near high quality waters, buffer zones and/or Environmentally Sensitive Areas (ESA)
- In areas where drainage areas are too large for a basin with a standard rock weir, and where the elevation difference between the inlet and the outlet ends will be 6 feet or greater.

**Use tiered skimmer basins when steeper terrain prohibits the use of other surface dewatering basin types.**

### Design Criteria

- The drainage area should be 10 acres or less.
- For each tiered basin, the length to width ratio should be at least 2:1, but not exceed 6:1.
- The basin depths should be at least 2 feet.
- The minimum total volume should be 1,800 cubic feet per acre of disturbed area.
- The minimum total surface area should be 325 square feet per cfs of  $Q_{10}$  peak inflow.
- The dewatering time should be between 48 hours and 72 hours.
- The emergency spillway of the lower basin should carry the peak runoff from the design storm with a minimum of 1-foot of freeboard in the spillway.
- The primary spillway lengths (feet) should be determined using  $Q/0.4$  where  $Q$  is the flow rate (cfs) into the upper basin. The primary spillway base lengths should be the same for all basins.
- The minimum primary spillway weir length should be 4 feet.
- A minimum of 3 coir fiber baffles should be installed in the tiered skimmer basin system.
- NCDOT Basin Design Spreadsheet should be used to design the basin.  
[http://www.ncdot.gov/doh/operations/dp\\_chief\\_eng/roadside/soil\\_water/erosion\\_control/downloads.html](http://www.ncdot.gov/doh/operations/dp_chief_eng/roadside/soil_water/erosion_control/downloads.html)

## 4.7.4 Tiered Skimmer Basin

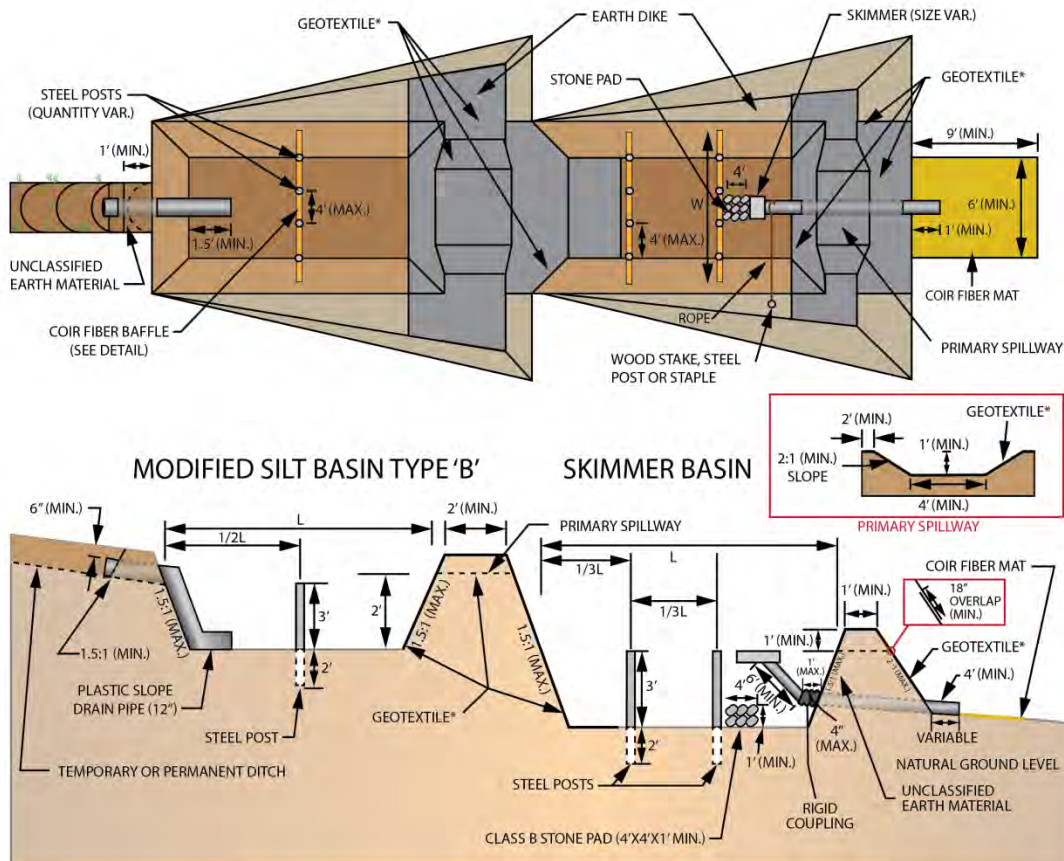

PLAN VIEW, CROSS SECTION AND PRIMARY SPILLWAY (NOT TO SCALE)

\* LOW PERMEABILITY GEOTEXTILE FOR EAST AREAS - DIVISIONS 1, 2, 3, 4, 6 AND 8.

PLACE A 6-INCH BAND OF SEALANT AROUND THE INTERIOR FACE OF THE OUTLET BARREL PIPE.

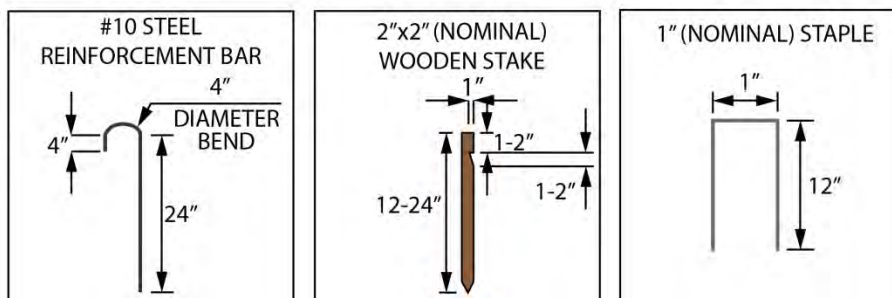

COIR FIBER MATT ANCHOR OPTIONS

## 4.7.4 Tiered Skimmer Basin



### Material Specifications

- The skimmer should meet the requirements of the Erosion and Sediment Control plan.
- Coir fiber baffles should meet the requirements of Section 1640-2 of the Standard Specifications.
- Coir fiber mat should meet the requirements of the Section 1060-14 of the Standard Specifications.
- Temporary slope drains should meet the requirements of Section 1622 of the Standard Specifications.
- Permanent or temporary seed should meet the requirements of Section 1060-4 of the Standard Specifications.
- Fertilizer for temporary seed should meet the requirements of Section 1060-2 of the Standard Specifications.
- Matting placed at the outlet for erosion control should meet the requirements of Section 1060-8 of the Standard Specifications.
- All embankment material should be considered unclassified earth.
- The geotextile should meet the requirements of Section 1056 of the Standard Specifications for Type 4 Geotextile for Soil Stabilization. For eastern Divisions 1, 2, 3, 4, and 6, the geotextile for the spillway liner shall meet the following minimum properties for low permeability, woven polypropylene geotextiles:

Geotextile Property	Test Method	Value	Unit
Tensile Strength	ASTM D4632	315	lb
Tensile Elongation (Maximum)	ASTM D4632	15	%
Trapezoidal Tear	ASTM D4533	120	lb
CBR (California Bearing Ratio)	ASTM D6241	900	lb
Puncture			
UV Resistance (% retained at 500 hrs.)	ASTM D4355	70	US Std. Sieve
Apparent Opening Size (AOS)	ASTM D4751	40	%
Permittivity	ASTM D4491	0.05	sec <sup>-1</sup>
Water Flow Rate	ASTM D4491	4	gal/min/ft <sup>2</sup>

## 4.7.4 Tiered Skimmer Basin



### Construction Specifications

<b>Installation</b>	<ul style="list-style-type: none"> <li>Construct the basins according to the Erosion and Sediment Control plan with the basin surface free of obstructions, debris and pockets of low-density material.</li> <li>Construct all upper basins as modified silt basins, Type B with the lowest basin built as a Skimmer Basin.</li> <li>Use additional modified silt basins, Type B as needed depending on the slope.</li> <li>Assemble and install the skimmer as instructed by the manufacturer.</li> <li>Place a 6-inch band of sealant around the interior face of the outlet barrel pipe.</li> <li>Depending on the expected time period for which the skimmer basin is designed, permanently or temporarily seed all bare side slopes of the basins.</li> </ul>
<b>Dimensions</b>	<ul style="list-style-type: none"> <li>Limit dam height of lower basin with skimmer to 5 feet.</li> <li>Install the skimmer a minimum of 1 foot from the bottom of the basin.</li> <li>The minimum basin widths should be 3 times the depth of the basin. For a basin depth of 3 feet, the minimum basin width should be 9 feet.</li> </ul>
<b>Matting</b>	<ul style="list-style-type: none"> <li>Install coir fiber matting under the outlet of the skimmer with minimum dimensions of 9 feet long by 6 feet wide.</li> <li>Install matting for erosion and sediment control on exposed side slopes after seeding is completed.</li> </ul>
<b>Geotextile</b>	<ul style="list-style-type: none"> <li>Unroll the geotextile on the spillways in the direction of the flow with edges buried at least 6 inches deep. The geotextile should be one continuous piece of material or overlapped a minimum of 18 inches.</li> <li>Install geotextile to cover the height of the outside of the lower basin berm outlet.</li> </ul>
<b>Baffles</b>	<ul style="list-style-type: none"> <li>Install a minimum of 3 coir fiber baffles in the tiered skimmer basin system. The baffle spacing should be <math>\frac{1}{3}</math> the basin length for basins with two baffles and a spacing of <math>\frac{1}{2}</math> the basin length for basins with one baffle.</li> </ul>
<b>Stone</b>	<ul style="list-style-type: none"> <li>Install a Class B stone pad (4 feet by 4 feet by 12 inches high) directly underneath the skimmer device.</li> </ul>
<b>Anchors</b>	<ul style="list-style-type: none"> <li>Anchor coir fiber mat with wooden stakes, steel reinforcement rebar or metal staples.</li> <li>Anchor geotextile with 6-inch staples and a maximum spacing of 3 feet.</li> </ul>
<b>Spillways</b>	<ul style="list-style-type: none"> <li>Construct primary spillways with a trapezoidal cross section with 2:1 or flatter side slopes and a minimum base width of 4 feet.</li> </ul>

## 4.7.4 Tiered Skimmer Basin



### Technician's Checklist

- Do not change the shape or size of the basin without consulting the Engineer.
- Verify the area where the basin is to be placed is permitted for the activity.
- Verify the area where the basin is proposed will be suitable for the device. Consider the soil type, water table and accessibility.
- Maintain access to the basin at all times so that it can be cleaned as needed.
- Remove the basin at the end of the project, if required.
- Meet the requirements of the plans or Standard Drawings for the pipe, earth dike, skimmer, spillway and baffles.
- Install the Class B stone pad beneath the skimmer location to prevent the skimmer from being buried in and clogged with sediment and debris if the water elevation becomes low.
- Compact the dam with good soil so that it can withstand the volume of water.
- Seed and mat the remainder of interior and exterior slope areas not covered with geotextile.

**Monitor for erosion and berm failure around each spillway between basins.**

### Measurement & Payment

Pay Items	Pay Units
Silt Excavation	Cubic Yard
Coir Fiber Mat	Square Yard
Geotextile for Drainage	Square Yard
Low Permeability Geotextile	Square Yard
Temporary Slope Drains	Linear Foot
___" Skimmer	Each
Riprap, Class ___	Ton
Seed for Temporary Seeding	Pound
Fertilizer for Temporary Seeding	Ton
Matting for Erosion Control	Square Yard

## 4.7.4 Tiered Skimmer Basin



### Maintenance

- Inspect the basin on a regular basis and after every significant rainfall event (1/2 inch or greater).
- Clean out the basins when sediment accumulations reach approximately one-half the height of the first baffle.
- Check the skimmer to make sure that it is not clogged with sediment.
- Check the geotextile lined spillway for damage.
- Check the coir fiber mat at the outlet of the skimmer to determine if a replacement is needed.
- During winter, support the skimmer at an angle such that water does not stand inside the barrel. This could result in the water freezing and plugging the skimmer.
- Repair seed and replace matting on the side slope areas that have eroded or have become damaged by equipment from silt cleanout.
- Remove sediment that may accumulate on the stone pad underneath the skimmer device.
- Inspect the baffles after each rain event for erosion damage and sediment accumulations.

### Typical Problems

- Basins are not constructed to the dimensions specified on the plans and result in inadequate basin capacities.
- Silt accumulations are not removed when needed.
- The basin is too deep, therefore safety is a concern.
- The skimmer becomes clogged.
- The stone pad beneath the skimmer device becomes covered with sediment and the skimmer becomes embedded in the bottom of the basin.
- The geotextile for the primary spillway is not keyed in well and water washes underneath it and the dam fails.
- Water flows under or around the coir fiber baffles and settling time decreases instead of increases.
- Equipment damages the side slopes of the basin during silt cleanout.
- Erosion of the side slopes occurs causing excess sediment to wash into the basin.

## 4.7.4 Tiered Skimmer Basin



*This page is intentionally left blank.*

## 4.7.5 Infiltration Basin with Baffles



### Definition

An infiltration basin with baffles is a sediment retention basin with a series of coir fiber baffles that can be utilized in areas where the soil permeability is at least 0.5 in/hr. If soil conditions are appropriate (see guidance below), most or all of the runoff entering the basin can be infiltrated, which makes this BMP desirable in areas that drain to jurisdictional water bodies.

### Practical Tips

- Knowing the ground water elevation is recommended for berm height construction around the basin.
- When sediment storage devices are needed, consider this BMP before others due to its high sediment capture efficiency and simple surface dewatering outlet.
- Infiltration basins require good soil permeability.

### Areas of Use

- Where soil conditions are sufficiently permeable (a minimum of 0.5 in/hr). Obtain soil infiltration rates from the USDA-NRCS Soil Surveys. Select the lower permeability of the soil horizon with the slowest permeability for conservative design.
- At drainage outlets that drain directly to jurisdictional water bodies and Riparian Buffer Zones
- At the toe of fill slopes but do not use in proposed ditches
- Do not place in “Soils Prone to Flooding”

## 4.7.5 Infiltration Basin with Baffles



### Design Criteria

- The drainage areas should not exceed 10 acres.
- The basin surface should be free of obstructions, debris and pockets of low-density material.
- The minimum surface area is 325 square feet per cfs of  $Q_{10}$  or  $Q_{25}$  peak inflow.
- The sediment storage requirement is 1800 cubic feet per disturbed acre.
- The primary spillway should carry the peak runoff from the design storm with a minimum 1 foot of freeboard depth in the spillway.
- The primary spillway length (feet) should be determined by using  $Q/0.4$ , where  $Q$  is the flow rate (cfs) into the basin.
- A minimum of 3 coir fiber baffles should be installed in the infiltration basin with a spacing of  $\frac{1}{4}$  the basin length.
- For infiltration basins less than 20 feet in length, 2 baffles shall be installed with a spacing of  $\frac{1}{3}$  the basin length.
- The minimum weir length is 4 feet.
- The maximum dewatering time is 3 days.
- NCDOT Infiltration Basin Design Spreadsheet should be used to design the basin.  
[http://www.ncdot.gov/doh/operations/dp\\_chief\\_eng/roadside/soil\\_water/erosion\\_control/downloads.html](http://www.ncdot.gov/doh/operations/dp_chief_eng/roadside/soil_water/erosion_control/downloads.html)

## 4.7.5 Infiltration Basin with Baffles

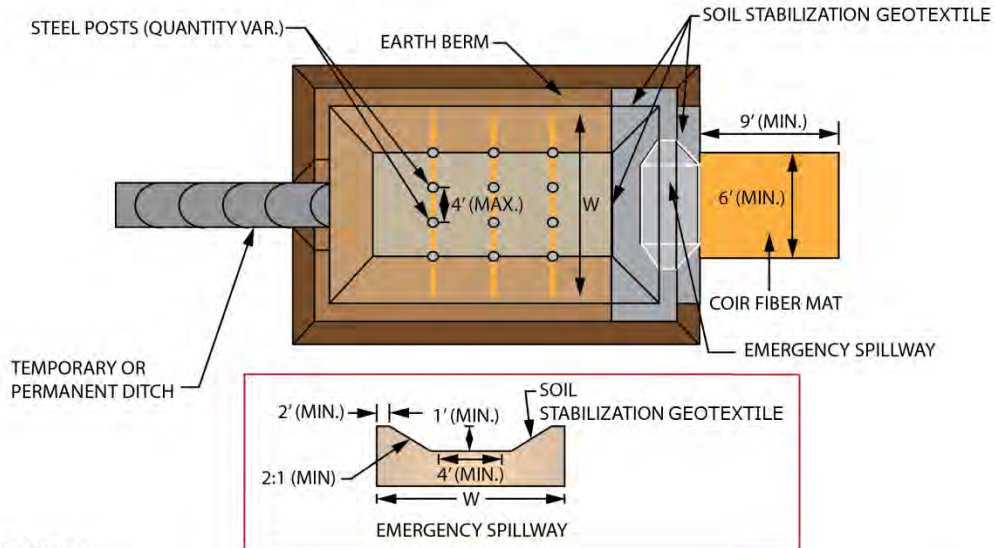

PLAN VIEW

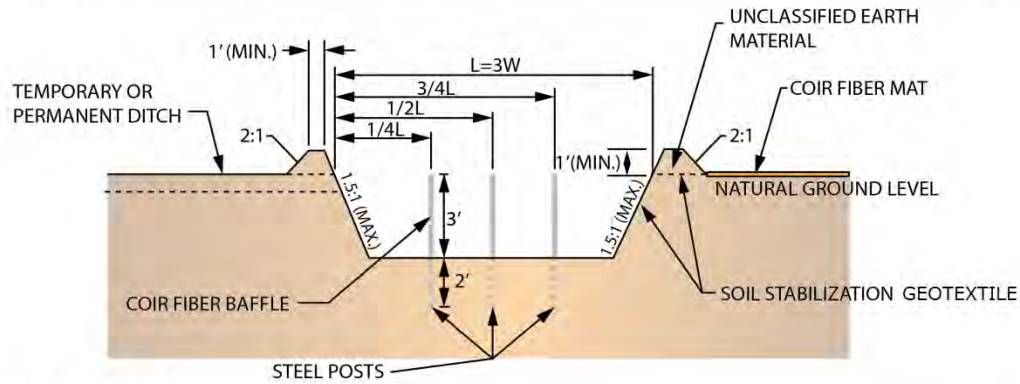

CROSS SECTION

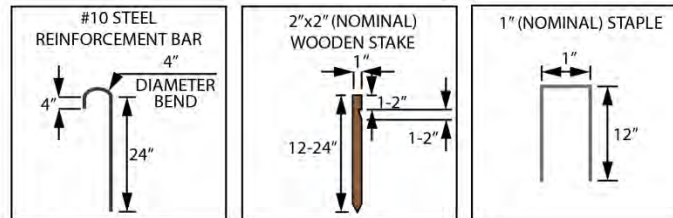

COIR FIBER MAT ANCHOR OPTIONS

## 4.7.5 Infiltration Basin with Baffles



### Material Specifications

Installation of the infiltration basin with baffles includes constructing the sediment basin, installation of coir fiber baffles, providing and placing geotextile spillway liner and providing coir fiber mat stabilization for the primary spillway outlet.

- Staples shall meet the requirements of NCDOT Standard Specification 1060-8.
- Coir fiber mat shall meet the requirements of NCDOT Standard Specification 1060-14.
- Coir fiber baffle shall meet the requirements of NCDOT Standard Specification 1640-2.
- Staples, stakes or reinforcement bars shall be used as anchors.

- **Avoid compaction of the proposed basin footprint by construction equipment.**
- **The floor of the basin must remain as clean as possible to function properly.**

### Geotextile

- In NCDOT Divisions 5, 7, 8, 9, 10, 11, 12, 13 and 14, for the geotextile spillway liner, utilize Geotextile for Soil Stabilization, Type 4, in accordance with NCDOT Standard Specification 1056.
- For eastern Divisions 1, 2, 3, 4, and 6, the geotextile for the spillway liner shall meet the following minimum properties for low permeability, woven polypropylene geotextiles:

Geotextile Property	Test Method	Value	Unit
Tensile Strength	ASTM D4632	315	lb
Tensile Elongation (Maximum)	ASTM D4632	15	%
Trapezoidal Tear	ASTM D4533	120	lb
CBR (California Bearing Ratio)	ASTM D6241	900	lb
Puncture			
UV Resistance (% retained at 500 hrs.)	ASTM D4355	70	US Std. Sieve
Apparent Opening Size (AOS)	ASTM D4751	40	%
Permittivity	ASTM D4491	0.05	sec <sup>-1</sup>
Water Flow Rate	ASTM D4491	4	gal/min/ft <sup>2</sup>

## 4.7.5 Infiltration Basin with Baffles



### Steel Reinforcement Bars

- Provide uncoated #10 steel reinforcement bars that are 24 inches nominal length. The bars shall have a 4-inch diameter bend at one end with a 4-inch straight section at the tip to catch and secure the coir fiber mat.

### Wooden Stakes

- Provide hardwood stakes that are 12 inches – 24 inches long with a 2-inch x 2-inch nominal square cross section.
- Sharpen or bevel one end of the stake to facilitate driving through the coir fiber mat and down into the underlying soil. The other end of the stake needs to have a 1-inch to 2-inch notch following to catch and secure the coir fiber mat.

### Staples

- Provide staples made of 0.125-inch diameter new steel wire formed into a U shape not less than 12 inches in length with a throat that is 1-inch wide.

## Construction Specifications

<b>Excavation</b>	<ul style="list-style-type: none"> <li>• Excavate the basin according to the E&amp;SC plans with the basin surface free of obstructions, debris and pockets of low-density material.</li> <li>• Excavation into or below the water table should not occur, and avoid compacting the bottom of the basin with equipment tires, excavation bucket, etc.</li> </ul>
<b>Coir Fiber Baffles</b>	<ul style="list-style-type: none"> <li>• Construct the coir fiber baffles according to Roadway Standard Drawing No. 1640.01 and Section 1640 of the Standard Specifications. Refer to Section 4.7.7 of this chapter for specific coir fiber baffle guidelines.</li> </ul>
<b>Earth Berm</b>	<ul style="list-style-type: none"> <li>• Construct earth berm around the perimeter of the infiltration basin as shown in the detail. The earth berm height shall be limited to 3 feet.</li> </ul>
<b>Primary Spillway</b>	<ul style="list-style-type: none"> <li>• Construct the primary spillway according to the Infiltration Basin with Baffles Detail sheet in the E&amp;SC plans.</li> <li>• Line the primary spillway with low permeability polypropylene geotextile unrolled in the direction of flow and lay it smoothly but loosely on the soil surface without creases.</li> <li>• At the primary spillway outlet, provide a smooth soil surface free from stones, clods or debris that will prevent contact of the coir fiber matting with the soil.</li> </ul>

## 4.7.5 Infiltration Basin with Baffles



<b>Geotextile</b>	<ul style="list-style-type: none"> <li>• Bury the edges of geotextile in a trench at least 5 inches deep and tamp firmly.</li> <li>• Make the vertical overlaps a minimum of 18 inches with upstream geotextile overlapping the downstream geotextile.</li> <li>• Secure the geotextile with 11-gauge U-shaped wire staples with a length of not less than 12 inches and a throat not less than 1-inch in width.</li> <li>• Place staples along the outer edges and throughout the geotextile spaced a maximum of 3 feet horizontally and vertically.</li> <li>• Extend the geotextile to the bottom and across the entire width of the basin according to the Infiltration Basin with Baffles detail.</li> </ul>
<b>Matting</b>	<ul style="list-style-type: none"> <li>• Unroll the matting and apply it without stretching such that it will lie smoothly but loosely on the soil surface.</li> </ul>
<b>Anchors</b>	<ul style="list-style-type: none"> <li>• Use wooden stakes, reinforcement bars or staples as anchors in accordance with the details in the plans and as directed.</li> <li>• Place anchors across the matting at the ends approximately 1 foot apart.</li> <li>• Place anchors along the outer edges and down the center of the matting 3 feet apart.</li> </ul>

### Technician's Checklist

- Perform an inspection of this device at least weekly and after each significant rainfall.
- Clean infiltration basins on a very frequent interval to keep the floor free of sediment deposition.
- Monitor the inlet of the basin for scour or erosion; supplement with a short section of temporary slope drain pipe to safely convey runoff into basin if needed.
- Monitor the geotextile-lined spillway and repair as needed if it becomes damaged.
- Remove devices as appropriate for the next phase of construction or when the final stand of vegetation has been established.

### Measurement & Payment

Pay Items	Pay Units
Coir Fiber Mat	Square Yard
Geotextile or Low Permeability Geotextile	Square Yard
Coir Fiber Baffle	Linear Foot
Silt Excavation	Cubic Yard

## 4.7.5 Infiltration Basin with Baffles



### Maintenance

- Inspect the basins after each significant rainfall.
- Clean the basins when any sediment accumulations appear on the basin floor.
- Check the geotextile-lined spillway for damage.
- Check the coir fiber mat at the outlet of the basin for damage.
- 

### Typical Problems

- Inadequate basin capacities: the basins are not constructed to dimensions specified on plans.
- Silt accumulations in the basin floor are not removed promptly.
- Geotextile for the spillway is not keyed in well and water washes underneath it causing the dam to fail.
- Water flows under or around coir fiber baffles and settling time decreases instead of increases.
- Equipment damages the side slopes of the basin during silt cleanout.
- Erosion of the side slopes occurs causing excess sediment to wash into the basin.

## 4.7.5 Infiltration Basin with Baffles



*This page is intentionally left blank.*

## 4.7.6 Temporary Rock Sediment Dam –Type A (1634.01)

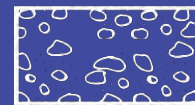

### Definition

A Temporary Rock Sediment Dam - Type A (TRSD-A) is a large dam structure with a weir outlet that forms a storage area behind it. The Type A dams utilize riprap lined with sediment control stone to trap sediment and protect off-site property. The TRSD-A is usually installed in an area where naturally formed drainage features allow for a large ponding or retention area to form where the dam is constructed at the outlet point. The TRSD-A can be constructed with some additional embankment material to help connect the stone dam to the existing features. The Type A dams can also be installed in existing and proposed roadway ditches with large cross sections.

### Practical Tips

- TRSD-A's are usually used in larger drainage areas where an embankment may be used to keep the effluent shallow with low velocities to allow trapping of sediment within construction boundaries.
- TRSD-A's are also placed at outlets to existing and proposed ditches with large cross sections.

## 4.7.6 Temporary Rock Sediment Dam –Type A (1634.01)

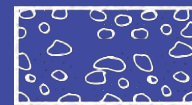

### Areas of Use

- At natural drainage outlets that form valleys or other topographic features that allow for a large detention area to be formed with the rock dam
- In watersheds where the drainage area is larger than 1 acre
- In large base ditches where the TRSD-A can be placed at the outlet and the stone will connect to the side slopes

**Do not use Temporary Rock Sediment Dams for surface dewatering.**

### Design Criteria

- The drainage area shall be limited to 10 acres or less.
- The minimum length to width ratio for the impoundment area is 2:1.
- The location should be accessible for maintenance for the entire life of the dam.
- The volume should be designed for 3,600 cubic feet per acre of disturbance.
- The surface area of the impoundment should be 435 square feet per cfs of the  $Q_{10}$  or  $Q_{25}$  peak inflow.
- Inflow to the dam should be located at the farthest point from the release point to prevent short-circuiting of the flow path and reduced settling efficiency.
- A minimum of 3 porous baffles should be constructed on the upstream side of the TRSD-A with equal spacing throughout the length of the impoundment behind the dam.
- The embankment side slopes should be 2:1 or flatter.
- The weir section should be  $\frac{2}{3}$  the width of the channel flow width with a minimum width of 4 feet.
- The weir section should be designed to pass the peak discharge of the design storm. A maximum flow depth of 6 inches, a minimum freeboard of 1 foot and maximum side slopes of 2:1 are recommended.
- The design life of the structure shall be 3 years or less.
- TRSD-A should not be placed at jurisdictional outlets where a surface dewatering device can be installed.
- Additional dam criteria are shown on the detail.

## 4.7.6 Temporary Rock Sediment Dam – Type A (1634.01)

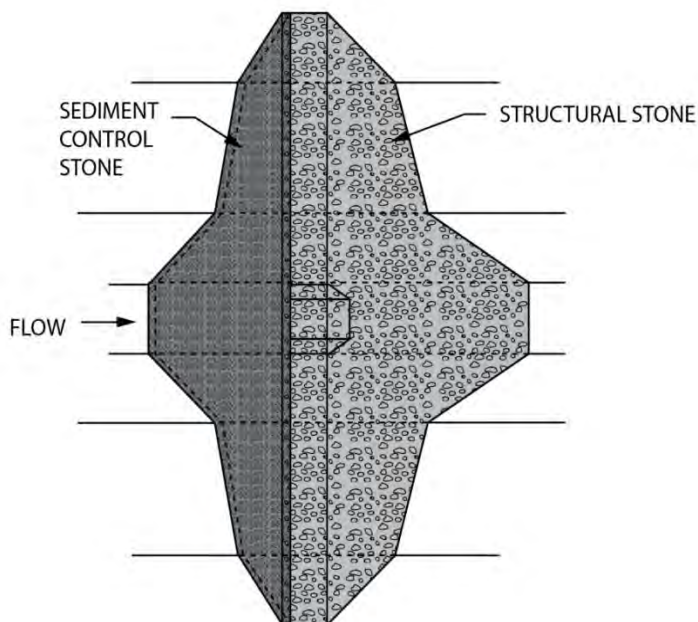
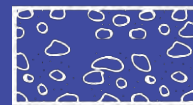

PLAN VIEW - TYPE A

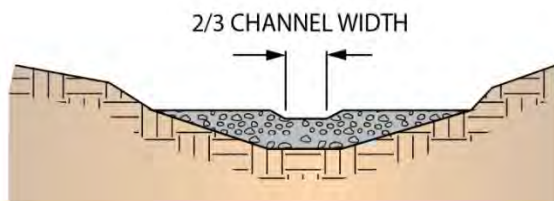

CROSS SECTION - TYPE A

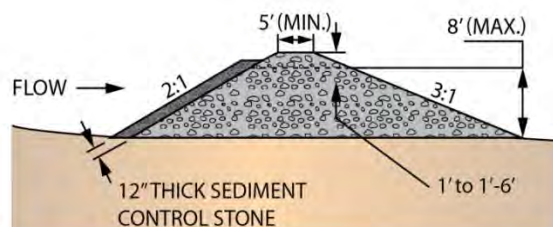

PROFILE VIEW - TYPE A

## 4.7.6 Temporary Rock Sediment Dam –Type A (1634.01)

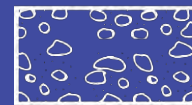

### Material Specifications

<b>Structural Stone</b>	<ul style="list-style-type: none"> <li>• Use Class I Riprap.</li> <li>• Meet the requirements of Section 1042 of the Standard Specifications for Rip Rap, Class 1.</li> </ul>
<b>Sediment Control Stone</b>	<ul style="list-style-type: none"> <li>• Use No. 5 or No. 57 stone.</li> <li>• Meet the requirements of Section 1005 of the Standard Specifications for stone sizes.</li> </ul>
<b>Baffles</b>	<ul style="list-style-type: none"> <li>• Meet the requirements of Section 1640-2 of the Standard Specifications.</li> </ul>

### Construction Specifications

<b>Specifications</b>	<ul style="list-style-type: none"> <li>• The maximum dam height is 8 feet with a weir elevation no more than 6 feet above grade.</li> <li>• Place the sediment control stone on the upstream face of the structural stone at a minimum thickness of 12 inches.</li> <li>• Construct the TRSD-A with a minimum top thickness of 5 feet with 2:1 slopes on the upstream side and 3:1 slopes on the downstream side.</li> <li>• Design the stone dam to a maximum of 8 feet above grade.</li> <li>• Compact the fill material for the area of embankment and rock dam tie in.</li> <li>• Install 3 coir fiber baffles in the impoundment area behind the TRSD-A with a minimum spacing of 15 feet as directed.</li> </ul>
-----------------------	------------------------------------------------------------------------------------------------------------------------------------------------------------------------------------------------------------------------------------------------------------------------------------------------------------------------------------------------------------------------------------------------------------------------------------------------------------------------------------------------------------------------------------------------------------------------------------------------------------------------------------------------------------------------------------------------------------------------

### Technician's Checklist

- Review permits to determine if dam installation is permitted.
- Locate dams as shown on the E&SC plans to control the velocity of water.
- Construct the dam with a weir that is low enough for the water to go over the dam before it will go around it and wash out the adjacent ditch slope.
- Install the proper type of dam based on the planned volume and velocity of water.
- Before the dam is removed, stabilize the drainage area with permanent vegetation.

**Temporary Rock Sediment Dams must be kept clean to allow the water to flow through the stone as they are designed to pond water for only a short period of time.**

## 4.7.6 Temporary Rock Sediment Dam –Type A (1634.01)

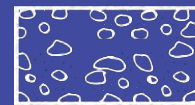

### Measurement & Payment

Pay Items	Pay Units
Riprap, Class 1	Ton
Sediment Control Stone	Ton
Coir Fiber Baffle	Linear Foot
Seed for Temporary Seeding	Pound
Fertilizer for Temporary Seeding	Ton
Silt Excavation	Cubic Yard

### Maintenance

- Inspect the TRSD-A on a regular basis and after each significant rainfall event.
- At a minimum, remove accumulated sediment when the measure reaches half full.
- As dam becomes clogged with sediment and runoff no longer passes through it, replace sediment control stone.
- Remove accumulated debris from the rock dam.
- Maintain the weir section of the dam when damaged by equipment or storms.

### Typical Problems

- Silt accumulations are not removed in a timely manner.
- The rock weir is poorly constructed.
- Stone is not replaced or maintained as sediment accumulates in it reducing porosity.
- The stone dam is not properly tied into the embankment of the basin.
- The structure is not rebuilt when damaged by storms, equipment, etc.

## 4.7.7 Temporary Rock Sediment Dam - Type B (1634.02)



### Definition

A Temporary Rock Sediment Dam - Type B (TRSD-B) is a small rock dam structure with a weir outlet and a built-in sediment basin. TRSD-B's are used at the outlet of drainage ways to detain sediment-laden waters and allow sediment particles to settle prior to the effluent being discharged into drainage ways or surrounding properties. The TRSD-B is composed of an excavated basin and a Class B rock dam faced with No. 5 or 57 washed stone.

### Practical Tips

- TRSD-B's are usually used in smaller drainage areas where an embankment may be used to keep the effluent shallow with low velocities to allow trapping of sediment within construction boundaries.
- TRSD-B's are typically placed at drainage outlets that do not drain directly to a jurisdictional water body.

## 4.7.7 Temporary Rock Sediment Dam - Type B (1634.02)



### Areas of Use

- At outlets of temporary diversions, temporary silt ditches, channels, temporary slope drains, at drainage pipe outlets or other runoff conveyance measures
- In areas where access can be maintained for regular maintenance
- Where runoff is leaving the construction site
- At existing small natural drainage turnouts

**Do not use Temporary Rock Sediment Dams for surface dewatering.**

### Design Criteria

- The drainage area shall not exceed 1 acre.
- The location should be accessible for maintenance for the entire life of the dam.
- The volume should be designed for 3,600 cubic feet per acre of disturbance.
- The surface area of the impoundment should be 435 square feet per cfs of the  $Q_{10}$  or  $Q_{25}$  peak inflow
- The basin length to width ratio should be at least 2:1, but not exceed 6:1.
- Inflow to the basin should be located at the farthest point from the release point to prevent short-circuiting of the flow path and reduced settling efficiency.
- A minimum of 3 porous baffles should be constructed within the basin of the TRSD-B with a spacing of 1/4 the basin length. For basins with less than 20 feet of length, the baffle spacing shall be 1/3 the basin length.
- The basin side slopes should 1.5:1 or flatter.
- TRSD-B should not be placed at jurisdictional outlets where a surface dewatering device can be installed.
- The weir section should be designed to pass the peak discharge of the design storm. A maximum flow depth of 6 inches, a minimum freeboard of 1 foot and a maximum side slope of 2:1 are recommended.
- The NCDOT Basin Designer Spreadsheet should be used to design the TRSD-B basin:  
[http://www.ncdot.gov/doh/operations/dp\\_chief\\_eng/roadside/soil\\_water/erosion\\_control/downloads.html](http://www.ncdot.gov/doh/operations/dp_chief_eng/roadside/soil_water/erosion_control/downloads.html)

## 4.7.7 Temporary Rock Sediment Dam - Type B (1634.02)

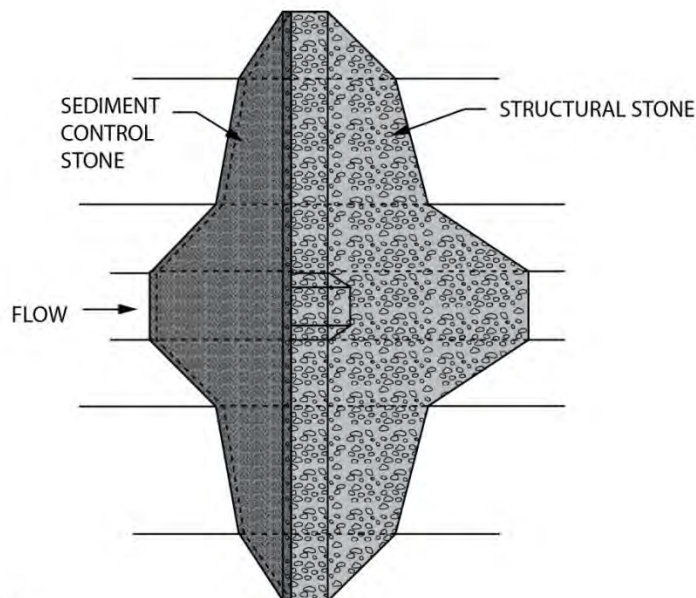

PLAN VIEW - TYPE B

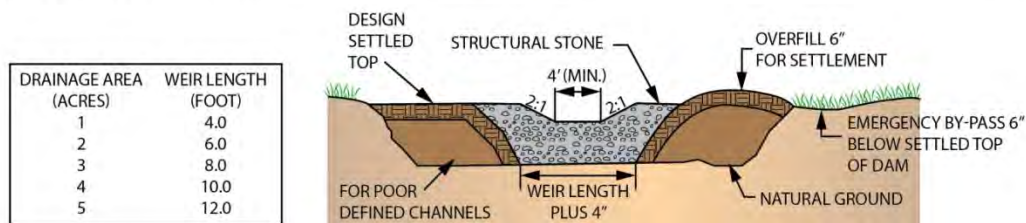

CROSS SECTION - TYPE B

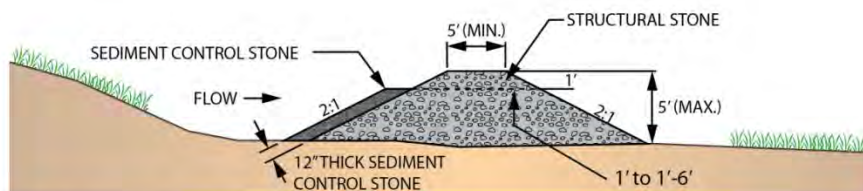

PROFILE SECTION - TYPE B

## 4.7.7 Temporary Rock Sediment Dam - Type B (1634.02)



### Material Specifications

<b>Structural Stone</b>	<ul style="list-style-type: none"> <li>Use Class B structural stone.</li> <li>Meet the requirements of Section 1042 of the Standard Specifications for Stone for Erosion Control, Class B.</li> </ul>
<b>Sediment Control Stone</b>	<ul style="list-style-type: none"> <li>Use No. 5 or No. 57 stone.</li> <li>Meet the requirements of Section 1005 of the Standard Specifications for stone sizes.</li> </ul>
<b>Baffles</b>	<ul style="list-style-type: none"> <li>Meet the requirements of Section 1640-2 of the Standard Specifications.</li> </ul>

### Construction Specifications

<b>Specifications</b>	<ul style="list-style-type: none"> <li>Place sediment control stone on the upstream face of the structural stone at a minimum thickness of 12 inches.</li> <li>Construct the rock dam with a minimum top thickness of 5 feet with 2:1 slopes.</li> <li>Construct the basin side slopes to 1.5:1 grade or flatter.</li> <li>Construct the stone dam to a maximum of 5 feet above grade.</li> <li>Compact fill material for embankment of basins.</li> <li>Install 3 coir fiber baffles in the TRSD-B, with a spacing of ¼ the basin length.</li> <li>Stabilize all interior and exterior slopes in accordance with Sections 1620 and 1660 of the Standard Specifications.</li> </ul>
-----------------------	-------------------------------------------------------------------------------------------------------------------------------------------------------------------------------------------------------------------------------------------------------------------------------------------------------------------------------------------------------------------------------------------------------------------------------------------------------------------------------------------------------------------------------------------------------------------------------------------------------------------------------------------------------------------------------------

### Technician's Checklist

- Review permits to determine if dam installation is permitted.
- Locate dams as shown on the E&SC plans to control the velocity of water.
- Construct the dam with a weir that is low enough for the water to go over the dam before it will go around it and wash out the adjacent ditch slope.
- Install the proper type of dam based on the planned volume and velocity of water.
- Before the dam is removed, stabilize the drainage area with permanent vegetation.

**Temporary Rock Sediment Dams must be kept clean to allow the water to flow through the stone as they are designed to pond water for only a short period of time.**

## 4.7.7 Temporary Rock Sediment Dam - Type B (1634.02)



### Measurement & Payment

Pay Items	Pay Units
Stone for Erosion Control, Class B	Ton
Sediment Control Stone	Ton
Coir Fiber Baffle	Linear Foot
Seed for Temporary Seeding	Pound
Fertilizer for Temporary Seeding	Ton
Silt Excavation	Cubic Yard

### Maintenance

- Inspect the TRSD-B on a regular basis and after each significant rainfall event.
- At a minimum, remove accumulated sediment when the measure reaches half full.
- As dam becomes clogged with sediment and runoff no longer passes through it, replace sediment control stone.
- Remove accumulated debris from the rock dam.
- Maintain the weir section of the dam when damaged by equipment or storms.

### Typical Problems

- Silt accumulations are not removed in a timely manner.
- The rock weir is poorly constructed.
- The interior of the basin erodes due to vertical side slope installation.
- Stone is not replaced or maintained as sediment accumulates in it reducing porosity.
- The stone dam is not properly tied into the embankment of the basin.
- The structure is not rebuilt when damaged by storms, equipment, etc.

## 4.7.8 Coir Fiber Baffle (1640.01)



### Practical Tips

- Install the required number of baffles detailed in the specifications immediately upon excavation of the basin.

### Definition

A coir fiber baffle is a porous barrier installed in sediment dams and silt basins. The baffles reduce the velocity of the runoff in the sediment control device, which facilitates the settling of sediment before being discharged offsite. The baffle consists of a coir fiber mat supported by steel T-posts. Baffles help prevent short-circuiting of flows through the device to the outlet point with little or no settling time. In addition, the baffles improve sediment retention because they distribute the flow, which reduces turbulence of the runoff inside the device.

### Areas of Use

- In all sediment dams, silt basins and skimmer basins located at drainage outlets
- Not in areas of concentrated flow with the exception of sediment storage devices in ditch lines

## 4.7.8 Coir Fiber Baffle (1640.01)

### Design Criteria

Use the following guidelines for coir fiber baffles required in Silt Basins at drainage turnouts, Type A and B Temporary Rock Sediment Dams, Skimmer and Infiltration Basins and Stilling Basins:

- 3 baffles if basin length > 20 feet
- 2 baffles if basin length 10 - 20 feet
- 1 baffle if basin length ≤ 10 feet
- When site constraints prevent basins from meeting the desired 3 foot depth, adjust the baffle to match basin depth

### Sediment Control Measures that Require Coir Fiber Baffles

- Riser Basin
- Silt Basin - Type B (at drainage outlets)
- Skimmer Basin
- Tiered Skimmer Basin
- Infiltration Basin
- Temporary Rock Sediment Dam – Type A
- Temporary Rock Sediment Dam – Type B
- Earthen Dam with Skimmer
- Stormwater Basin with Skimmer
- Stilling Basin

## 4.7.8 Coir Fiber Baffle (1640.01)

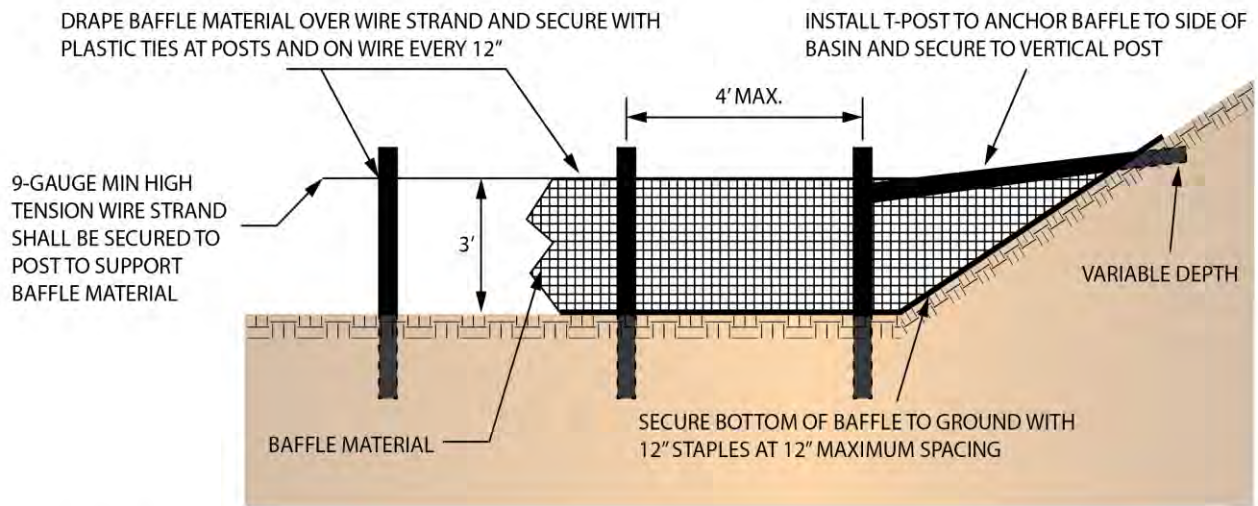

SIDE VIEW

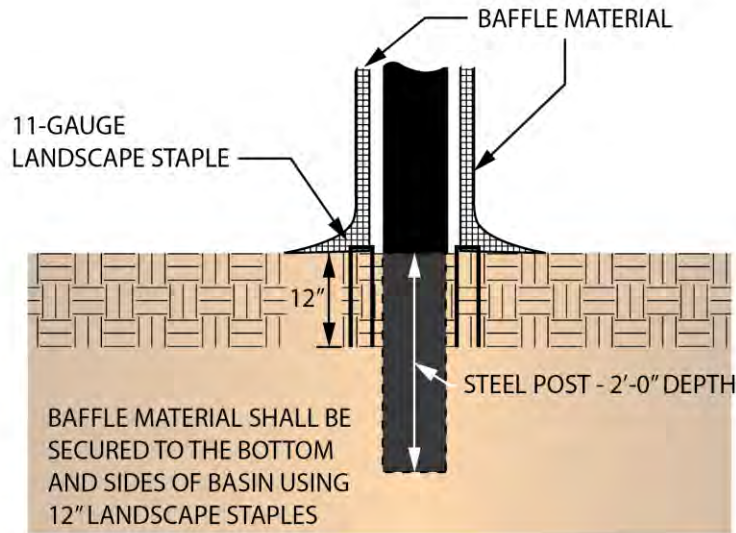

CROSS SECTION

## 4.7.8 Coir Fiber Baffle (1640.01)

### Material Specifications

- Coir fiber mat, posts, wire and wire staples shall meet the requirements of Section 1640-2 of the Standard Specifications.
- The coir fiber mat shall have a minimum width of 6.5 feet.
- Matting should be provided to meet the requirements of the Standard Specifications Table 1640-1 in Section 1640-2, as shown below:

**Table 1640-1 Coir Fiber Mat Properties**

Property	Requirement
Composition	100% coconut fiber (coir) twine woven into high strength matrix
Thickness	0.30" minimum
Tensile Strength	1,348 x 626 lb/ft minimum
Elongation	34% x 38% maximum
Flexibility (mg-cm)	65030 x 29590
Flow Velocity	Observed 11 ft/sec
Weight	20 oz/yd <sup>2</sup>
Size	6.6 x 164 ft (120 yd <sup>2</sup> )
"C" Factor	0.002
Open Area (measured)	50%

### Staples

- Provide staples made of 0.125-inch diameter new steel, 11-gauge wire formed into a U-shape not less than 12 inches in length with a throat of 1 inch in width.

### Posts

- Provide steel posts at least 5 feet in length, approximately 1 3/8-inches wide measured parallel to the fence with a minimum weight of 1.25 lb/ft of length.
- Equip the post with an anchor plate having a minimum area of 14.0 square inches and of the self-fastener angle steel type to provide a means of retaining the wire and coir fiber mat in the desired position without displacement.

### Wire

- Provide a 9-gauge high tension wire strand of variable lengths.

## 4.7.8 Coir Fiber Baffle (1640.01)

### Construction Specifications

<b>When to Install</b>	<ul style="list-style-type: none"> <li>• Install the coir fiber baffles immediately upon construction of the sediment dams and basins.</li> <li>• Install 3 baffles in the sediment control device at a spacing of <math>\frac{1}{4}</math> the basin length.</li> <li>• Install only 2 baffles at a spacing of <math>\frac{1}{3}</math> the basin length, if the impoundment area of the device is less than 20 feet in length.</li> <li>• Use only 1 baffle for basin lengths less than 10 feet.</li> </ul>
<b>How to Install</b>	<ul style="list-style-type: none"> <li>• Install 5-foot steel T-posts to a minimum depth of 2 feet and maximum spacing of 4 feet.</li> <li>• Attach 9-gauge minimum high tension wire to the top of the posts so that the coir fiber mat can be draped over it to measure a minimum of 3 feet in height.</li> <li>• Secure the bottom of the coir fiber mat with 12-inch staples at a maximum spacing of 12 inches.</li> <li>• Install 5-foot T-posts into the side slopes of the basin to anchor the nearest vertical post.</li> </ul>

### Technician's Checklist

- Baffle locations shall be consistent with the requirements of the E&SC plans.
- Confirm there are 3 baffles in the basins and sediment dams with a spacing of  $\frac{1}{4}$  of the length when the device is > 20 feet.
- Confirm there are 2 baffles in the basins and sediment dams with a spacing of  $\frac{1}{3}$  of the length when the device is < 20 feet.
- Confirm there is 1 baffle in devices that are < 10 feet.
- Confirm that the coir fiber mat meets the requirements for weight and opening.
- The fence posts shall meet the specification requirements and be installed to a depth of 2 feet.
- There should be at least 3 feet of coir fiber draped on each side of the wire strand.
- Secure the bottom with staples at 12 inches on center.

**Over time, accumulated silt should be removed and deteriorated baffles repaired.**

### Measurement & Payment

#### Pay Items

Coir Fiber Baffle

#### Pay Units

Linear Foot

## 4.7.8 Coir Fiber Baffle (1640.01)

### Maintenance

- Inspect baffles on a regular basis and after each significant rainfall event. Make any repairs immediately.
- Inspect coir fiber baffle to be sure the ends of the mat are anchored into the ground or side slopes with staples.
- At a minimum, remove sediment from the device when it reaches  $\frac{1}{2}$  the baffle height, and do not damage the baffles during sediment cleanout.
- Remove and replace deteriorated or clogged baffles.
- Install additional posts or wire backing if baffle is sagging.

### Typical Problems

- Baffles are not secured appropriately to the ground and side slopes.
- The appropriate number of baffles is not used.
- Baffles are not spaced in accordance with design criteria.
- Silt and debris is not removed and allowed to accumulate.

## 4.7.9 Earthen Dam with Skimmer (Detail)

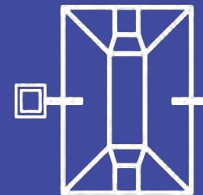

### Practical Tips

- Utilize where ditch grades are less than 2%
- Matting should be unrolled and applied loosely without stretching.
- Geotextile should lay smoothly, but loosely on soil surface without creases.

### Definition

An earthen dam with skimmer is used in roadway ditches to remove sediment from construction site runoff at locations specified in the Erosion and Sediment Control plans. Components of the earthen dam with skimmer include the construction of an earthen dam, installation of coir fiber baffles, and installation of a skimmer.

### Areas of Use

- In roadway ditches, typically ditches with large cross-section (i.e., base ditches)

The skimmer orifice is designed to dewater the device in 2 to 3 days per the NCDOT Earthen Dam with Skimmer Design Spreadsheet.

## 4.7.9 Earthen Dam with Skimmer (Detail)

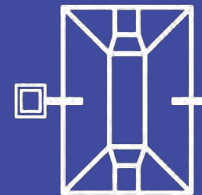

### Design Criteria

- The drainage area should be 10 acres or less.
- The ditch sediment storage depth should be at least 2 feet.
- The earthen dam height should be limited to 5 feet.
- The minimum detention volume should be 1,800 cubic feet per acre of disturbed area.
- The minimum ponded surface area should be 325 square feet per cfs of  $Q_{10}$  or  $Q_{25}$  peak inflow.
- The dewatering time should be between 48 hours and 72 hours.
- The primary spillway should carry the peak runoff from the design storm with a minimum 1 foot of storage depth in the spillway.
- The primary spillway weir length (feet) should be equal to  $Q/0.4$ , where  $Q$  is the flow rate (cfs) in the ditch.
- The minimum primary spillway weir length should be 4 feet.
- A minimum of 3 coir fiber baffles should be installed in the ditch with the earthen dam with skimmer with a spacing of 15 feet.
- The NCDOT Earthen Dam with Skimmer Designer Spreadsheet should be used to design the earthen dam with skimmer.

[http://www.ncdot.gov/doh/operations/dp\\_chief\\_eng/roadside/soil\\_water/erosion\\_control/downloads.html](http://www.ncdot.gov/doh/operations/dp_chief_eng/roadside/soil_water/erosion_control/downloads.html)

## 4.7.9 Earthen Dam with Skimmer (Detail)

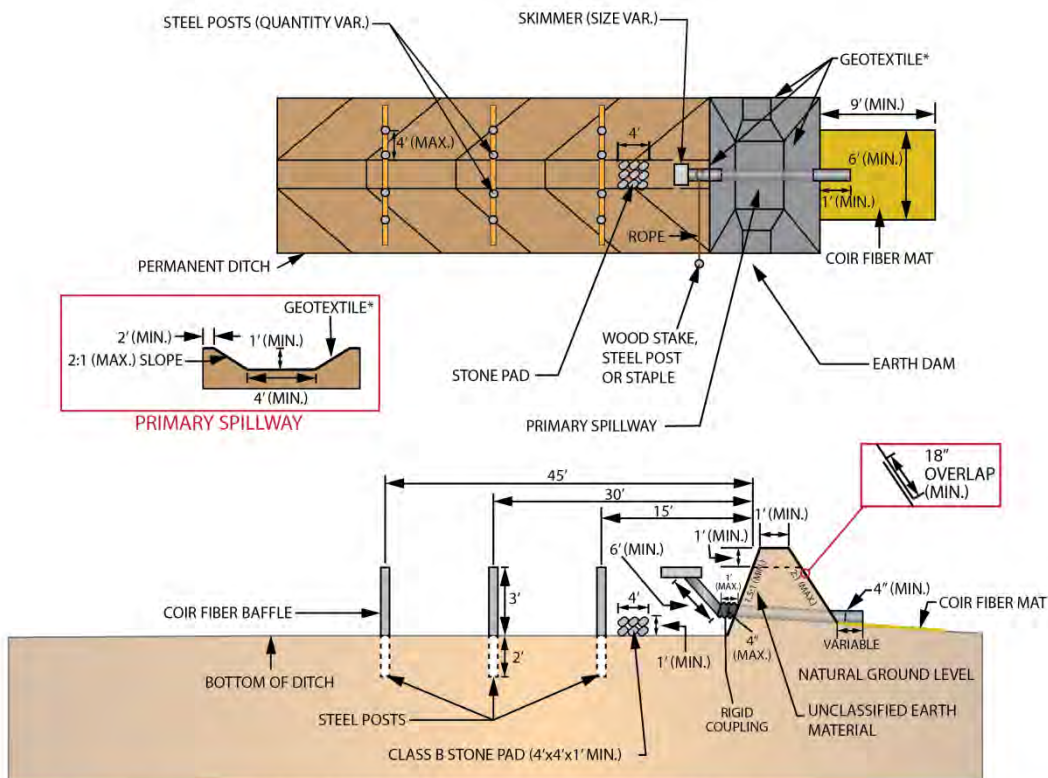
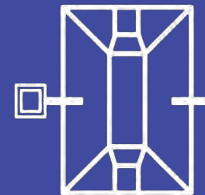

PLAN VIEW, CROSS SECTION AND PRIMARY SPILLWAY (NOT TO SCALE)

\* LOW PERMEABILITY GEOTEXTILE FOR EAST AREAS - DIVISIONS 1, 2, 3, 4, AND 6.

PLACE A 6-INCH BAND OF SEALANT AROUND THE INTERIOR FACE OF THE OUTLET BARREL PIPE.

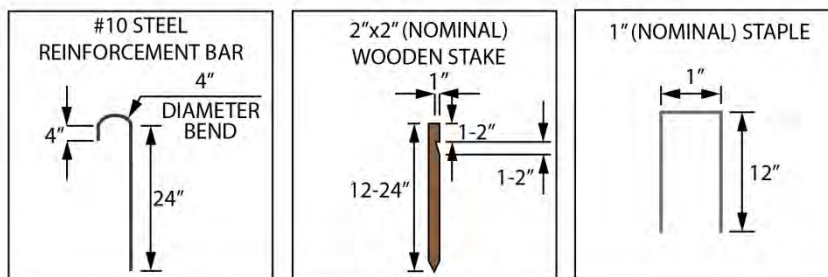

COIR FIBER MATT ANCHOR OPTIONS

## 4.7.9 Earthen Dam with Skimmer (Detail)

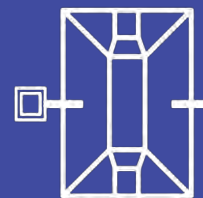

### Material Specifications

- The skimmer should meet the requirements of the Erosion and Sediment Control plan.
- The geotextile should meet the requirements of Section 1056 of the Standard Specifications for Type 2 Fabric. For areas in the east, Divisions 1, 2, 3, 4, and 6, low permeability geotextile should be used.
- Coir fiber baffles should meet the requirements of Section 1640 of the Standard Specifications.
- Coir fiber mat should meet the requirements of Section 1060-14 of the Standard Specifications.
- Permanent or temporary seed should meet the requirements of Section 1060-4 of the Standard Specifications.
- Fertilizer for temporary seed should meet the requirements of Section 1060-2 of the Standard Specifications.
- Matting for erosion control should meet the requirements of Section 1060-8 of the Standard Specifications.
- All embankment material should be considered unclassified earth.
- Structural stone shall be Class B stone that meets the requirements of Section 1042 of the Standard Specifications for Stone for Erosion Control, Class B.
- Staples should meet the requirements of Section 1060-8 of the Standard Specifications.

Geotextile Property	Test Method	Value	Unit
Tensile Strength	ASTM D4632	315	lb
Tensile Elongation (Maximum)	ASTM D4632	15	%
Trapezoidal Tear	ASTM D4533	120	lb
CBR (California Bearing Ratio)	ASTM D6241	900	lb
Puncture			
UV Resistance (% retained at 500 hrs.)	ASTM D4355	70	US Std. Sieve
Apparent Opening Size (AOS)	ASTM D4751	40	%
Permittivity	ASTM D4491	0.05	sec <sup>-1</sup>
Water Flow Rate	ASTM D4491	4	gal/min/ft <sup>2</sup>

## 4.7.9 Earthen Dam with Skimmer (Detail)

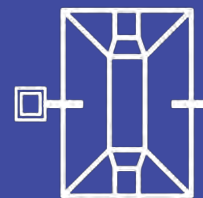

### Construction Specifications

<b>Installation</b>	<ul style="list-style-type: none"> <li>• Construct the earthen dam with skimmer according to the Erosion and Sediment Control plan with the ditch and dam surfaces free of obstructions, debris and pockets of low-density material.</li> <li>• Assemble and install the skimmer as instructed by the manufacturer.</li> <li>• Place a 6-inch band of sealant around the interior face of the outlet barrel pipe.</li> <li>• Depending on the expected time period for which the earthen dam is designed, permanently or temporarily seed all bare side slopes of the ditch.</li> </ul>
<b>Dimensions</b>	<ul style="list-style-type: none"> <li>• Limit the dam height to 5 feet.</li> <li>• Install the skimmer a minimum of 1 foot from the bottom of the ditch.</li> </ul>
<b>Matting</b>	<ul style="list-style-type: none"> <li>• Install coir fiber matting under the outlet of the skimmer with minimum dimensions of 9 feet long by 6 feet wide.</li> <li>• Install matting for erosion control on exposed side slopes after seeding is completed.</li> </ul>
<b>Geotextile</b>	<ul style="list-style-type: none"> <li>• Unroll the geotextile on the spillway in the direction of flow, with edges buried at least 6 inches deep. The geotextile should be one continuous piece of material or overlapped a minimum of 18 inches. For Divisions 1, 2, 3, 4, and 6 in the eastern part of the state, use a low permeability geotextile.</li> <li>• Shall be placed at the bottom and across the entire width of the ditch berm and according to the Earthen Dam with Skimmer detail.</li> </ul>
<b>Baffles</b>	<ul style="list-style-type: none"> <li>• Install 3 coir fiber baffles in the ditch beginning 15 feet upgrade from the primary spillway, each with a spacing of 15 feet. Refer to the section on coir fiber baffles.</li> </ul>
<b>Stone</b>	<ul style="list-style-type: none"> <li>• Install a Class B stone pad (4 feet by 4 feet by 12 inches high) directly underneath the skimmer device.</li> </ul>

## 4.7.9 Earthen Dam with Skimmer (Detail)

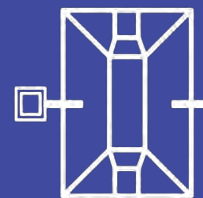

<p><b>Anchors</b></p>	<ul style="list-style-type: none"> <li>Anchor the coir fiber mat with wooden stakes, steel reinforcement rebar or metal staples. Anchors shall be at the ends of the matting approximately 1 foot apart and along outer edges and down the center of the matting 3 feet apart.</li> <li>Anchor the geotextile with 6-inch staples and a maximum spacing of 3 feet horizontally and vertically.</li> <li>Wooden stakes shall be 12-inch to 24-inch long with a 2" x 2" nominal square cross section. One end of the stake must be sharpened or beveled. The other end needs to have a 1-inch to 2-inch long head at the top with a 1-inch to 2-inch notch to secure the mat.</li> <li>Steel reinforcement bars shall be uncoated, #10 rebar that are 24 inches long. The bars shall have a 4-inch diameter bend at one end with a 4-inch straight section at the tip to catch and secure the coir fiber mat.</li> <li>Staples shall be made of 0.125-inch diameter 11-gauge new steel wire formed into a U shape not less than 12 inches long with a throat of 1 inch wide.</li> </ul>
<p><b>Primary Spillway</b></p>	<ul style="list-style-type: none"> <li>Construct the primary spillway with a trapezoidal cross-section to a depth of 12 inches and a minimum base width of 4 feet.</li> </ul>
<p><b>Skimmer</b></p>	<ul style="list-style-type: none"> <li>Provide Schedule 40 PVC arm pipe with a length of 6 feet to attach the skimmer to the coupling at the barrel pipe.</li> <li>For skimmer sizes 2.5 inches and smaller, the arm pipe diameter shall be 1.5 inches.</li> <li>For skimmer sizes of 3 inches and larger, refer to the manufacturer recommendation for arm pipe diameter.</li> <li>Provide a 4-inch diameter Schedule 40 PVC pipe to attach to the coupling connection of the skimmer and serve as the barrel pipe through the earthen dam.</li> </ul>

## 4.7.9 Earthen Dam with Skimmer (Detail)

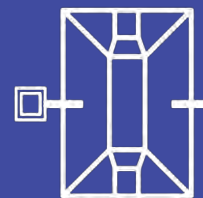

### Technician's Checklist

- Do not change the location, shape or size of the earthen dam without consulting with the Engineer.
- Verify the area where the earthen dam is to be placed is permitted for the activity.
- Verify the area where the dam is proposed will be suitable for the device. Consider the soil type, water table, ditch grade and accessibility.
- Maintain access to the earthen dam at all times so that it can be cleaned as needed.
- Remove the device at the end of the project.
- Meet the requirements of the plans or Standard Drawings for the pipe, earth dam, skimmer, spillway and baffles.
- Install the Class B stone pad beneath the skimmer location to prevent the skimmer from being buried in and clogged with sediment and debris if the water elevation becomes low.
- Construct the dam with clay soil and compact to prevent basin water seepage into the dam.
- Seed and mat the remainder of interior and exterior slope areas not covered with geotextile.
- The geotextile should be one continuous piece of material or overlapped a minimum of 18 inches.

### Measurement & Payment

The construction of the earthen dam will be paid for as Borrow Excavation as provided in Section 230 of the Standard Specifications or included in the lump sum price for grading.

Pay Items	Pay Units
Silt Excavation	Cubic Yard
Coir Fiber Mat	Square Yard
Geotextile for Drainage	Square Yard
Low Permeability Geotextile	Square Yard
__" Skimmer	Each
Riprap, Class ____	Ton
Seed for Temporary Seeding	Pound
Fertilizer for Temporary Seeding	Ton
Coir Fiber Baffles	Linear Foot
Matting for Erosion Control	Square Yard

## 4.7.9 Earthen Dam with Skimmer (Detail)

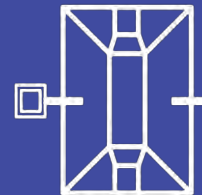

### Maintenance

- Inspect the dam on a regular basis and after every significant rainfall event (1/2 inch or greater).
- Clean out the ditch and baffles when sediment accumulations reach approximately one-half the height of the first baffle. Silt should also be removed from the earthen dam on a regular basis.
- Check the skimmer to make sure that it is not clogged with sediment.
- Check the geotextile lined spillway for damage.
- Check the coir fiber mat at the outlet of the skimmer to determine if it is in need of replacement.
- During winter, support the skimmer at an angle such that water does not stand inside the barrel. This could result in the water freezing and plugging the skimmer or cracking the PVC.
- Reseed and replace matting on the side slope areas that have eroded or have become damaged by equipment from silt cleanout.
- Remove sediment that may accumulate on the stone pad underneath the skimmer device.
- Inspect the baffles after each rain event for erosion damage and sediment accumulations.

### Typical Problems

- Dams are not constructed to the dimensions specified on the plans and result in inadequate capacities.
- Silt accumulations are not removed when needed.
- The ditch is too deep and causing a safety concern.
- The skimmer becomes clogged.
- The stone pad beneath the skimmer device becomes covered with sediment and the skimmer becomes embedded in the bottom of the ditch.
- The geotextile for the primary spillway is not keyed in well, water washes underneath it, and the dam fails.
- Water flows under or around the coir fiber baffles and settling time decreases instead of increases.
- Equipment damages side slopes of the ditch or dam during silt cleanout.
- Erosion of the side slopes causes excess sediment to wash into the ditch.

## 4.7.10 Stormwater Basin with Skimmer



### Definition

A stormwater basin with skimmer uses the location of proposed permanent stormwater basins to remove sediment from construction site runoff at locations specified in the Erosion and Sediment Control plans. Components of the stormwater basin with skimmer include the construction of a basin, installation of coir fiber baffles, and installation of a skimmer. At the conclusion of construction, the riser is removed and grouted.

### Areas of Use

- At proposed permanent stormwater basins, if indicated in the Erosion and Sediment Control plans

### Practical Tips

- Good compaction and suitable material for the berm for the stormwater basin is required.
- If the designed size of the stormwater basin is too large for allowable footprint, consider using flocculant up gradient.

The skimmer orifice is designed to dewater the basin in 2 to 3 days per the NCDOT Stormwater Basin with Skimmer Design Spreadsheet.

## 4.7.10 Stormwater Basin with Skimmer

### Design Criteria

- The drainage area should be 10 acres or less.
- The basin depth should be at least 2 feet.
- The basin length-to-width ratio should be at least 2:1 but should not exceed 6:1.
- The minimum detention volume should be 1,800 cubic feet per acre of disturbed area.
- The minimum ponded surface area should be 435 square feet per cfs of  $Q_{10}$  or  $Q_{25}$  peak inflow.
- The dewatering time should be between 48 hours and 72 hours.
- The primary spillway is the skimmer. The skimmer dewateres the water quality volume designed.
- The emergency spillway is the riser. The riser provides an emergency bypass for the runoff from the design storm.
- The riser should conform to the guidance given in the most current NCDOT Best Management Practices (BMP) Toolbox for stormwater basin with skimmer design standards.
- From the drawing, “E” is the design storm elevation or the invert elevation of the riser; “D” is the height of the embankment. For requirements associated with dimension “D”, refer to the most recent version of the NCDOT BMP Toolbox.
- A minimum of 3 coir fiber baffles should be installed in the stormwater basin with skimmer.
- The NCDOT Stormwater Basin with Skimmer Designer Spreadsheet should be used to design the stormwater basin with skimmer.

[http://www.ncdot.gov/doh/operations/dp\\_chief\\_eng/roadside/soil\\_water/erosion\\_control/downloads.html](http://www.ncdot.gov/doh/operations/dp_chief_eng/roadside/soil_water/erosion_control/downloads.html)

## 4.7.10 Stormwater Basin with Skimmer

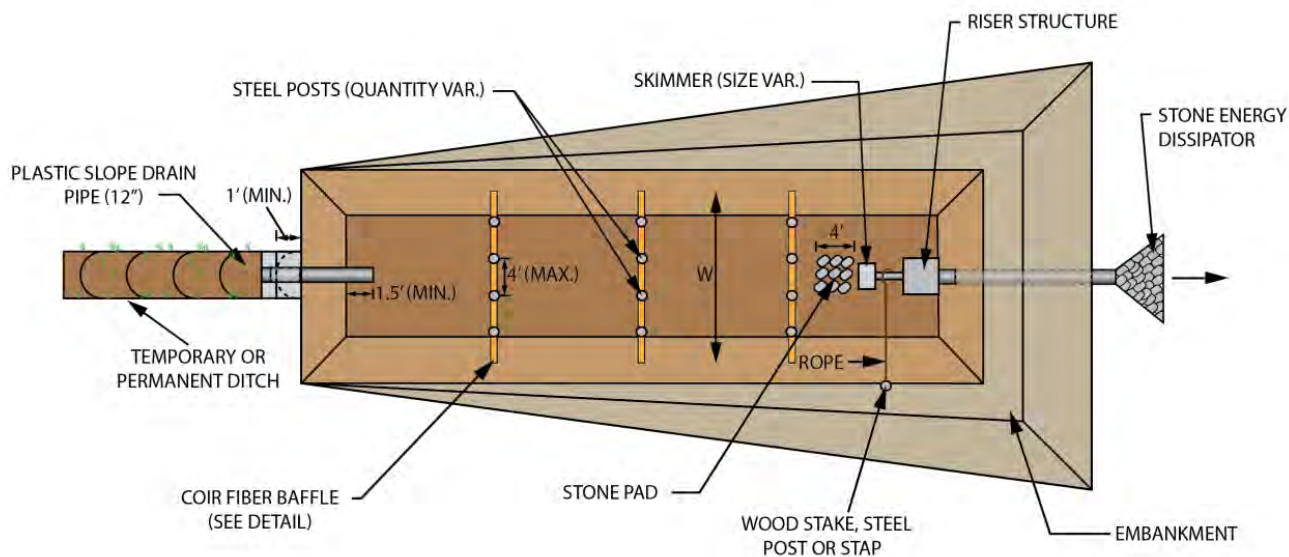

PLAN VIEW (NOT TO SCALE)

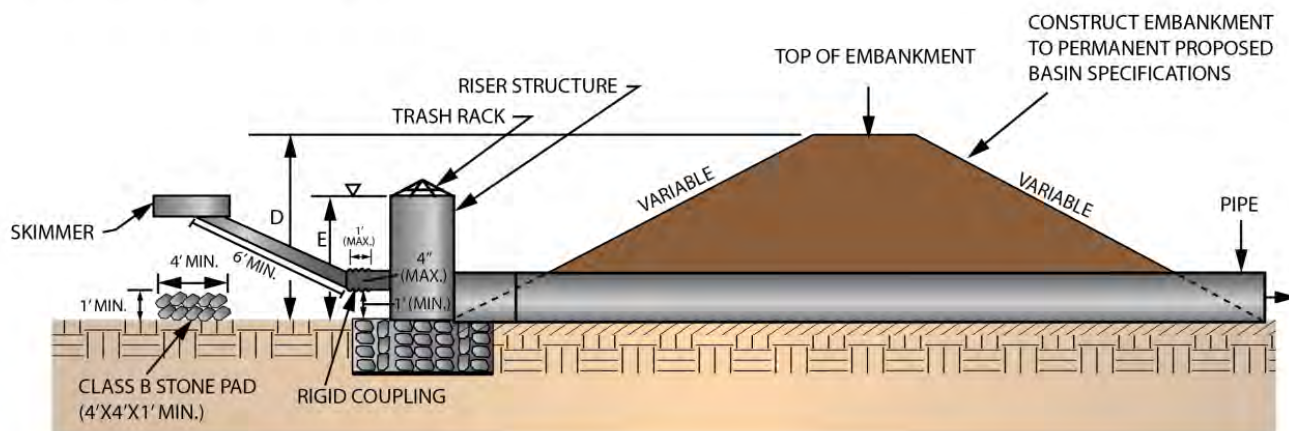

SECTIONAL VIEW (NOT TO SCALE)

## 4.7.10 Stormwater Basin with Skimmer

### Material Specifications

- The skimmer should meet the requirements of the Erosion and Sediment Control plan.
- Coir fiber baffles should meet the requirements of Section 1640-2 of the Standard Specifications.
- Coir fiber mat should meet the requirements of Section 1060-14 of the Standard Specifications.
- Permanent or temporary seed should meet the requirements of Section 1060-4 of the Standard Specifications.
- Fertilizer for temporary or permanent seed should meet the requirements of Section 1060-2 of the Standard Specifications.
- Matting for erosion control should meet the requirements of Section 1060-8 of the Standard Specifications.
- All embankment material should be considered unclassified earth.
- Structural stone shall be Class B stone that meets the requirements of Section 1042 of the Standard Specifications for Stone for Erosion Control, Class B.
- Staples should meet the requirements of Section 1060-8 of the Standard Specifications.
- Plastic Slope Drain Pipe should meet the requirements of Section 1622-2 of the Standard Specifications.
- Pipe connecting the skimmer to the riser structure shall be Schedule 40 PVC.

### Construction Specifications

<b>Installation</b>	<ul style="list-style-type: none"> <li>• Construct the stormwater basin with skimmer according to the Erosion and Sediment Control plan with the basin surfaces free of obstructions, debris and pockets of low-density material.</li> <li>• Assemble and install the skimmer as instructed by the manufacturer.</li> <li>• Place a 6-inch band of sealant around the interior face of the outlet barrel pipe.</li> <li>• Depending on the expected time period for which the stormwater basin is designed, permanently or temporarily seed all bare side slopes of the ditch.</li> </ul>
<b>Dimensions</b>	<ul style="list-style-type: none"> <li>• Limit the dam height to 12 feet. Refer to NCDOT BMP Toolbox for dam height dimensions.</li> <li>• Install the skimmer a minimum of 1 foot from the bottom of the basin.</li> <li>• The basin width should be 3 times the depth of the basin. For a basin depth of 3 feet, the minimum basin width should be 9 feet.</li> </ul>
<b>Matting</b>	<ul style="list-style-type: none"> <li>• Install matting for erosion control on exposed side slopes after seeding is completed.</li> </ul>
<b>Baffles</b>	<ul style="list-style-type: none"> <li>• Install 3 coir fiber baffles in the stormwater basin with a spacing of <math>\frac{1}{4}</math> the basin length. Refer to the section on coir fiber baffles.</li> </ul>

## 4.7.10 Stormwater Basin with Skimmer

<b>Anchors</b>	<ul style="list-style-type: none"> <li>Anchor the coir fiber mat with wooden stakes, steel reinforcement rebar or metal staples.</li> <li>Anchors shall be at the ends of the matting approximately 1 foot apart and along outer edges and down the center of the matting 3 feet apart.</li> <li>Anchor the geotextile with 6-inch staples and a maximum spacing of 3 feet horizontally and vertically.</li> <li>Wooden stakes shall be 12-inch to 24-inch long with a 2" x 2" nominal square cross section. One end of the stake must be sharpened or beveled. The other end needs to have a 1-inch to 2-inch long head at the top with a 1-inch to 2-inch notch to secure the mat.</li> <li>Steel reinforcement bars shall be uncoated, #10 rebar that are 24 inches long. The bars shall have a 4-inch diameter bend at one end with a 4-inch straight section at the tip to catch and secure the coir fiber mat.</li> <li>Staples shall be made of 0.125-inch diameter 11-gauge new steel wire formed into a U shape not less than 12 inches long with a throat of 1 inch wide.</li> </ul>
<b>Stone</b>	<ul style="list-style-type: none"> <li>Install a Class B stone pad (4 feet by 4 feet by 12 inches high) directly underneath the skimmer device.</li> <li>Install stone energy dissipater at outlet.</li> </ul>
<b>Skimmer</b>	<ul style="list-style-type: none"> <li>Provide Schedule 40 PVC arm pipe with a length of 6 feet to attach the skimmer to the coupling at the barrel pipe.</li> <li>For skimmer sizes 2.5 inches and smaller, the arm pipe diameter shall be 1.5 inches.</li> <li>For skimmer sizes of 3 inches and larger, refer to the manufacturer recommendation for arm pipe diameter.</li> <li>Provide a 4-inch diameter Schedule 40 PVC pipe to attach to the rigid coupling connection of the skimmer and serve as the barrel pipe through the earthen dam and tie into the riser.</li> </ul>
<b>Riser</b>	<ul style="list-style-type: none"> <li>Construction specifications should conform to the methods outlined in the most recent version of the NCDOT BMP Toolbox.</li> </ul>

## 4.7.10 Stormwater Basin with Skimmer

### Technician's Checklist

- Do not change the location, shape or size of the stormwater basin without consulting with the Engineer.
- Verify that the area where the stormwater basin is to be placed is permitted for the activity.
- Verify that the area where the basin is proposed will be suitable for the device. Consider the soil type, water table, ditch grade and accessibility.
- Maintain access to the basin at all times so that it can be cleaned as needed.
- At conclusion of construction, the remove the riser and grout.
- Meet the requirements of the plans or Standard Drawings for the pipe, earth dam, skimmer, spillway and baffles.
- Install the Class B stone pad beneath the skimmer location to prevent the skimmer from being buried in and clogged with sediment and debris if the water elevation becomes low.
- Compact the dam with clay soil to prevent seepage and failure.
- Seed and mat the interior and exterior slope areas.

### Measurement & Payment

The construction of the earthen dam will be paid for as Borrow Excavation as provided in Section 230 of the Standard Specifications or included in the lump sum price for grading.

Pay Items	Pay Units
Silt Excavation	Cubic Yard
Coir Fiber Mat	Square Yard
Low Permeability Geotextile	Square Yard
__" Skimmer	Each
Riprap, Class ____	Ton
Seed for Temporary Seeding	Pound
Fertilizer for Temporary Seeding	Ton
Seeding and Mulching	Acres
Coir Fiber Baffles	Linear Foot
Matting for Erosion Control	Square Yard
Temporary Slope Drains	Linear Foot

## 4.7.10 Stormwater Basin with Skimmer

### Maintenance

- Inspect the basin on a regular basis and after every significant rainfall event (1/2 inch or greater).
- Clean out the basin and baffles when sediment accumulations reach approximately one-half the height of the first baffle. Silt should also be removed from the earthen dam on a regular basis.
- Check the skimmer to make sure that it is not clogged with sediment.
- Check the stone at the outlet to determine if it is in need of replacement or repair.
- During winter, support the skimmer at an angle such that water does not stand inside the barrel. This could result in the water freezing and plugging the skimmer or cracking the PVC.
- Reseed and replace matting on the side slope areas that have eroded or have become damaged by equipment from silt cleanout.
- Remove sediment that may accumulate on the stone pad underneath the skimmer device.
- Inspect the baffles after each rain event for erosion damage and sediment accumulations.

### Typical Problems

- Basins are not constructed to the dimensions specified on the plans and result in inadequate capacities.
- Silt accumulations are not removed when needed.
- Erosion occurs at the inlet end when the basin is too deep.
- The basin is too deep and causing a safety concern.
- The skimmer becomes clogged.
- The stone pad beneath the skimmer device becomes covered with sediment, and the skimmer becomes embedded in the bottom of the basin.
- Water flows under or around the coir fiber baffles and settling time decreases instead of increases.
- Equipment damages side slopes of the basin during silt cleanout.
- Erosion of the side slopes causes excess sediment to wash into the basin.

# 4.8

## Section

### Managing the Watercourse

Temporary Stream Crossing	4.8.1
Impervious Dike	4.8.2
Stilling Basin	4.8.3
Special Stilling Basin	4.8.4

Occasionally projects require work in an existing waterway or the crossing of small streams and wetlands for brief periods of time. As a result, water must be temporarily diverted. This section outlines the proper procedures for temporarily diverting watercourses while minimizing impacts to the wetland or stream.

## 4.8.1 Temporary Stream Crossing (1645.01)



### Practical Tips

- Do not utilize temporary stream crossings in areas of high flow.

### Definition

Temporary stream crossings are utilized where construction traffic needs to travel over small streams and wetlands. The crossing consists of geotextile on the existing ground and pipe(s) installed to convey stream flow, with stone placed around the pipe(s).

### Areas of Use

Install temporary stream crossings:

- On small streams or wetlands where construction vehicles need to travel from one side of the stream to the other for a short period of time

**Plan ahead to have sediment control measures designed and installed at the four ditch line entry points at the temporary stream crossings.**

### Design Criteria

- Pipe(s) for temporary stream crossing shall be designed to pass the peak or bankfull flow, whichever is less, from a 2-year storm, without overtopping.

## 4.8.1 Temporary Stream Crossing (1645.01)

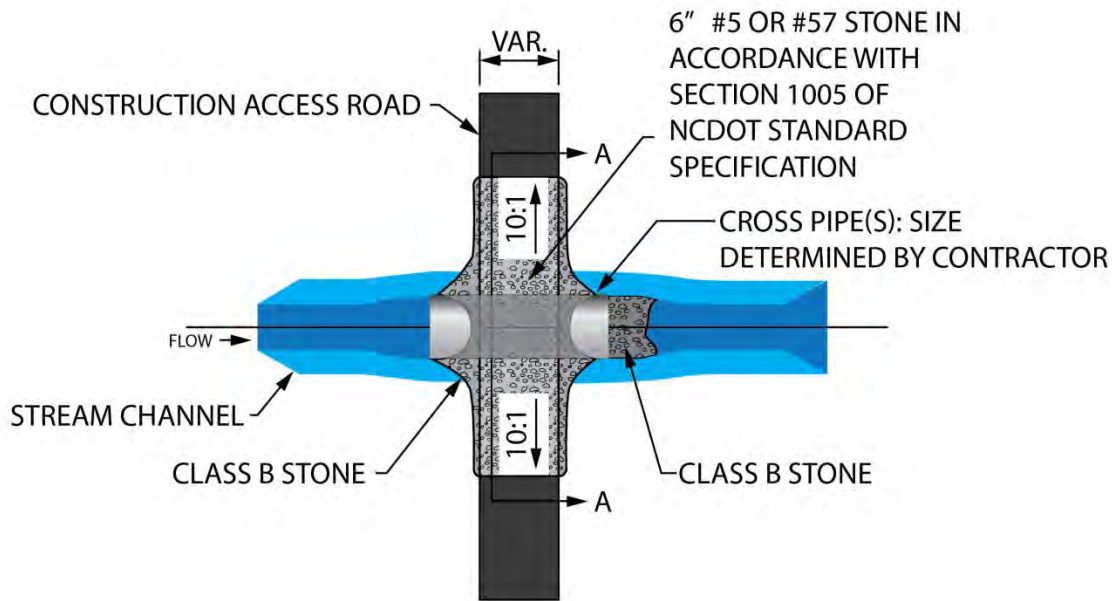

PLAN VIEW

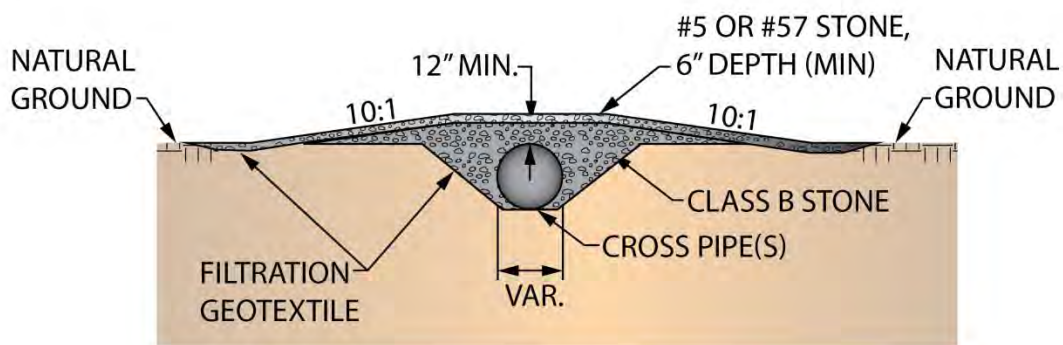

CROSS SECTION - PLAN VIEW REFERENCE A (NOT TO SCALE)

## 4.8.1 Temporary Stream Crossing (1645.01)

### Material Specifications

- Filtration geotextile shall meet the requirements of Section 1056 of the Standard Specifications for Type 2 Geotextile.
- Class B stone shall meet the requirements of Section 1042 of the Standard Specifications for Stone for Erosion Control, Class B.
- No. 57 stone shall meet the requirements of Section 1005 of the Standard Specifications for this stone size.
- Temporary pipe(s) should have adequate strength to withstand stone and equipment loads.

### Construction Specifications

The temporary stream crossing must be allowed in the project permits. The pipe for the crossing should be sized for the 2-year storm. Pipe sizing calculations should be reviewed by the Engineer. The crossing is paid for per unit pipe and stone. The smaller the pipe, the more stone is required. Larger pipe is less costly overall and reduces the amount of time spent hauling and/or removing stone.

<b>Stream Crossing</b>	<ul style="list-style-type: none"> <li>• Slope of approaches to the stream crossing should be no steeper than 10:1.</li> <li>• At a minimum, construct the width of the stream crossing to be the same as the construction access road.</li> </ul>
<b>Geotextile</b>	<ul style="list-style-type: none"> <li>• Place geotextile on the streambed channel, along streambanks and into flood plain at a minimum of 15 feet in width.</li> </ul>
<b>Piping</b>	<ul style="list-style-type: none"> <li>• More than one temporary pipe may be used, and size and number shall be included on the plans.</li> </ul>
<b>Stone</b>	<ul style="list-style-type: none"> <li>• Structural stone of the crossing shall be Class B and placed around the temporary pipe(s).</li> <li>• Class B stone shall be placed to a minimum of 12 inches over the pipe(s).</li> <li>• No. 57 stone shall be placed on top of the Class B stone at a minimum depth of 6 inches and tied into existing ground.</li> </ul>

## 4.8.1 Temporary Stream Crossing (1645.01)

### Technician's Checklist

- Reference the permits to make sure they allow the crossing installation.
- Make sure the pipe sizing calculations have been received.
- Install the geotextile prior to the pipe and stone.

**Using larger pipe will reduce the amount of stone required.**

### Measurement & Payment

Pay Items	Pay Units
Geotextile for Drainage, Type 2	Square Yard
Erosion Control Stone, Class B	Ton
Sediment Control Stone	Ton
Temporary Pipe for Stream Crossing	Linear Foot

### Maintenance

- Inspect filtration geotextile, stone and pipe(s) after each significant rainfall.
- Replace geotextile and replenish the stone when they become contaminated with sediment.
- Damaged temporary pipe(s) should be repaired or replaced immediately.
- Replace any Class B or No. 57 stone that gets dislodged or damaged.
- Clean pipe(s) if clogged with debris.

**The No. 57 stone will require replenishing if sediment builds up as a result of construction traffic.**

### Typical Problems

- Pipe(s) are damaged by vehicle traffic due to inadequate wall thickness.
- An inadequate amount of Class B stone around the pipe(s) causes the temporary stream crossing to dislodge and erode during a heavy rain event.
- The geotextile is not placed underneath the stone and pipe(s) properly causing runoff to undermine the device.
- Inadequate maintenance is performed.

## 4.8.1 Temporary Stream Crossing (1645.01)

*This page is intentionally left blank.*

## 4.8.2 Impervious Dike



### Practical Tips

- Impervious dikes are used in stream channels, upstream of the project site, to anchor temporary pipe, and to create the side of temporary channels.
- When used for temporary diversion, install at the upstream location first.

### Definition

Impervious dikes are used to divert normal stream flow around a construction site. Acceptable materials for impervious dikes include, but are not limited to, sheet piles, sandbags and/or the placement of an acceptable size stone lined with polypropylene (“poly”) or other impervious geotextile.

Sheet piles are a “Z” cross-section piling that is driven into the ground and interlocked to create a wall or bulkhead. Sheet piles can be used to detain water in low flow conditions or coupled with bypass pumps to keep a site moderately dry during construction.

Sand bags can be manually stacked to form a temporary impervious dike when encapsulated with an impervious poly-geotextile liner (note: liner is not always utilized with sandbags). This impervious dike can be used to impound or divert water and can be easily removed.

An impervious dike can also be created through the use of stone encapsulated with a high tensile impervious geotextile. This configuration can be used to either impound or divert water. This barrier can be constructed to conform to the shape of the existing channel.

## 4.8.2 Impervious Dike

### Areas of Use

#### Sheet Piles

- Where minimum channel disturbance required
- Where this is the preferred method of sealing the work area from the water recourse for pipe sizes of 48 inches and greater
- Not in small channels with little or no flow
- Not where the access to drive piles requires more disturbance to the watercourse than other impervious dikes

**Do not use sheet piles in locations where rocks or obstructions prevent piles from being driven.**

#### Sandbags

- When low flow conditions exist
- When the height of the dike is less than 5 feet
- When heavy equipment cannot be utilized
- Not when using concrete in sand mixture

#### Stone Lined with Polypropylene

- When the size of the pipe is less than 48 inches
- When heavy equipment is available for installation
- When the channel has an irregularly shaped cross section

### Design Criteria

- The dike height should be 1 foot higher (2 feet minimum height including base flow) than the stream base flow for sandbags and stone lined with polypropylene.
- Sheet piles should include a panel driven deeper to create a weir for overflow conditions.

## 4.8.2 Impervious Dike

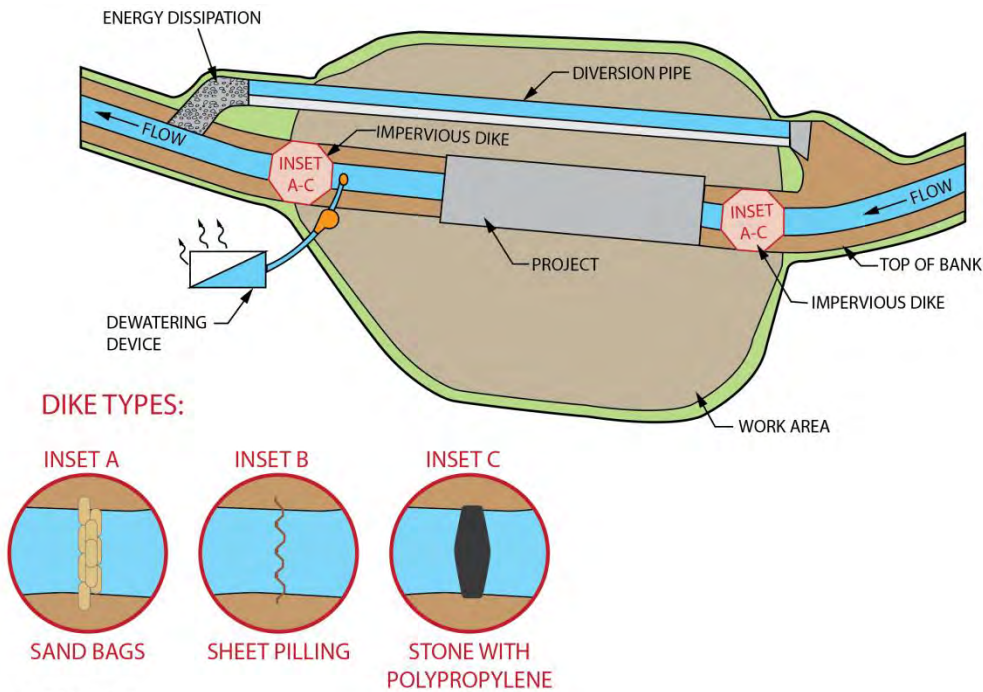

PLAN VIEW

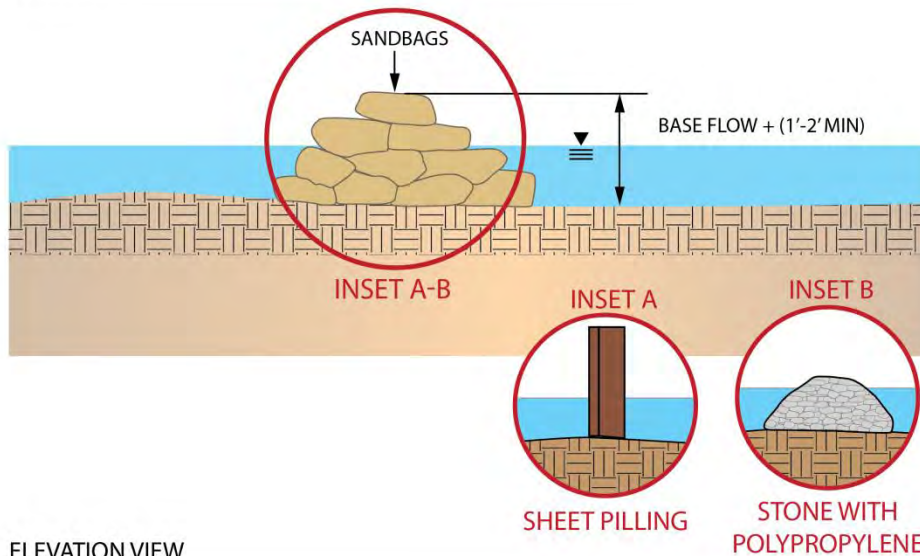

## 4.8.2 Impervious Dike

### Material Specifications

- Steel sheet piles detailed for temporary applications shall be hot rolled and meet the requirements of ASTM A328.
- The geotextile shall have low permeability and should be a polypropylene and/or polyethylene material.
- Proper geotextile certifications must meet Section 1056 of the Standard Specifications.

### Construction Specifications

#### Sheet Pile

Specifications	<ul style="list-style-type: none"> <li>• Install the sheet pile by placing and driving piles with a backhoe, excavator, hammer or other suitable equipment.</li> <li>• Pile shall be free of dirt, grease and other potential contaminants before installation.</li> <li>• Penetrate to a sufficient depth in order to bear the load of water being diverted.</li> <li>• Overlap or interlock piles in a manner that prevents any seepage of water into the work area and prevents seepage of sediment from the work area into the stream.</li> <li>• Remove trapped debris and sediment prior to removing sheet pile.</li> </ul>
----------------	-----------------------------------------------------------------------------------------------------------------------------------------------------------------------------------------------------------------------------------------------------------------------------------------------------------------------------------------------------------------------------------------------------------------------------------------------------------------------------------------------------------------------------------------------------------------------------------------------------------------------------------

#### Sandbags

Specifications	<ul style="list-style-type: none"> <li>• Remove branches and large rocks from the area where the sand bags will be placed.</li> <li>• If using a liner, lay out the impervious poly-geotextile liner with the center of the liner located over the center of the sand bag dike.</li> <li>• Place the sandbags to the desired height. The dikes shall have a width suitable to support the height. Each row shall be offset so the joints are staggered. Pack sandbags tightly together.</li> <li>• Wrap impervious poly-geotextile liner around sandbag dike and secure with a final layer of sandbags.</li> </ul>
----------------	--------------------------------------------------------------------------------------------------------------------------------------------------------------------------------------------------------------------------------------------------------------------------------------------------------------------------------------------------------------------------------------------------------------------------------------------------------------------------------------------------------------------------------------------------------------------------------------------------------------------

## 4.8.2 Impervious Dike

### Stone Lined with Polypropylene

- Prepare the channel and overbanks for installation.
- Remove all branches and debris from the area where the stone dike will be placed.
- Make sure that there are no sharp rocks or roots that can puncture the geotextile.
- Do not excavate the existing channel or banks.
- Place the high tensile impervious geotextile with the center over the center of the proposed dike. Utilize a small amount of stone to hold down the geotextile while adjustments are being made.
- There should be enough extra geotextile on each side of the dike to wrap up and over the stone dike to make it impervious.
- Pile stone on top of the geotextile to create the dike structure.
- Roll geotextile up over the stone to form an impervious dike.
- Roll the top layer from the upstream to downstream direction. Secure geotextile with metal fence stakes or other suitable material.

### Technician's Checklist

- Never use earth material for an impervious dike unless vegetation can be established prior to direct contact with the stream takes place.
- Don't allow stone to enter water body or stream.
- Reclaim any sand or "unconsolidated material" from the stream as a result of bag rupture.
- Leave a sheet pile panel(s) at a lower elevation for overflow conditions.

### Measurement & Payment

Impervious dikes will be measured and paid as the actual number of linear feet of impervious dike(s) constructed, measured in place from end to end of each separate installation that has been completed and accepted. Such price and payment will be full compensation for all work including but not limited to furnishing materials, construction, maintenance and removal of the impervious dike.

#### Pay Items

Impervious Dike

#### Pay Units

Linear Feet

## 4.8.2 Impervious Dike

### Maintenance

#### Sheet Piles

- Inspect sheet piles daily for water leaks and signs of instability and implement repair procedures accordingly.

#### Sandbags

- Periodically inspect sandbag dike for damage and leaks and repair as needed.
- Remove impounded trash and sediment.

#### Stone Lined with Polypropylene

- Periodically inspect dike for damage and leaks and repair as needed.
- Remove impounded trash and sediment.

### Typical Problems

#### Sheet Piles

- Improperly installed piles will leak.
- Piles not driven deep enough will fail under the pressure of the water.

#### Sandbags

- Leakage occurs due to improper construction or liner failure.
- Blow-outs may occur from large storm events.

#### Stone Lined with Polypropylene

- Leakage occurs through punctures in the poly.
- Blow-outs may occur from large storm events.
- Erosion occurs around the side of the dike.

## 4.8.3 Stilling Basin (1630.04)



### Definition

A stilling basin is a rectangular-shaped basin formed by mounded soil with a permeable stone drain located at the outlet end. A stilling basin is used where water is pumped from construction sites. Sediment-laden water is pumped into the impoundment where heavier particles settle out, and then the water is allowed to drain back to the receiving stream.

### Areas of Use

Install stilling basins in these locations:

- Where streams are diverted at culvert construction sites
- Where sediment-laden water at construction sites must first be treated before returning to natural streams
- At coffer dam sites
- Where large volumes of water will be pumped from the work area

### Practical Tips

- When determining the size of the basin, do not calculate any volume for depth below the water table or above the flow line of the overflow pipe.
- Coir fiber baffles are necessary to settle suspended solids.
- A flashboard riser or fabric lined spillway are acceptable substitutes for the permeable stone drain.

- Direct the pump outlet to a stone dissipater, not to the dikes or basin bottom.
- Monitor pump flow rate so that water is retained within the basin and suspended solids can settle.

## 4.8.3 Stilling Basin (1630.04)



### Design Criteria

- The stilling basin should not be placed in wetlands or Environmentally Sensitive Areas (ESA).
- The stilling basin should not be placed in areas of concentrated flows such as channels and ditches.
- The stilling basin size is variable and dependent on specific site requirements as well as proposed construction operations. Minimum design volumes are provided on the E&SC plans.
- The volume of the basin is only that which is above ground water elevation.

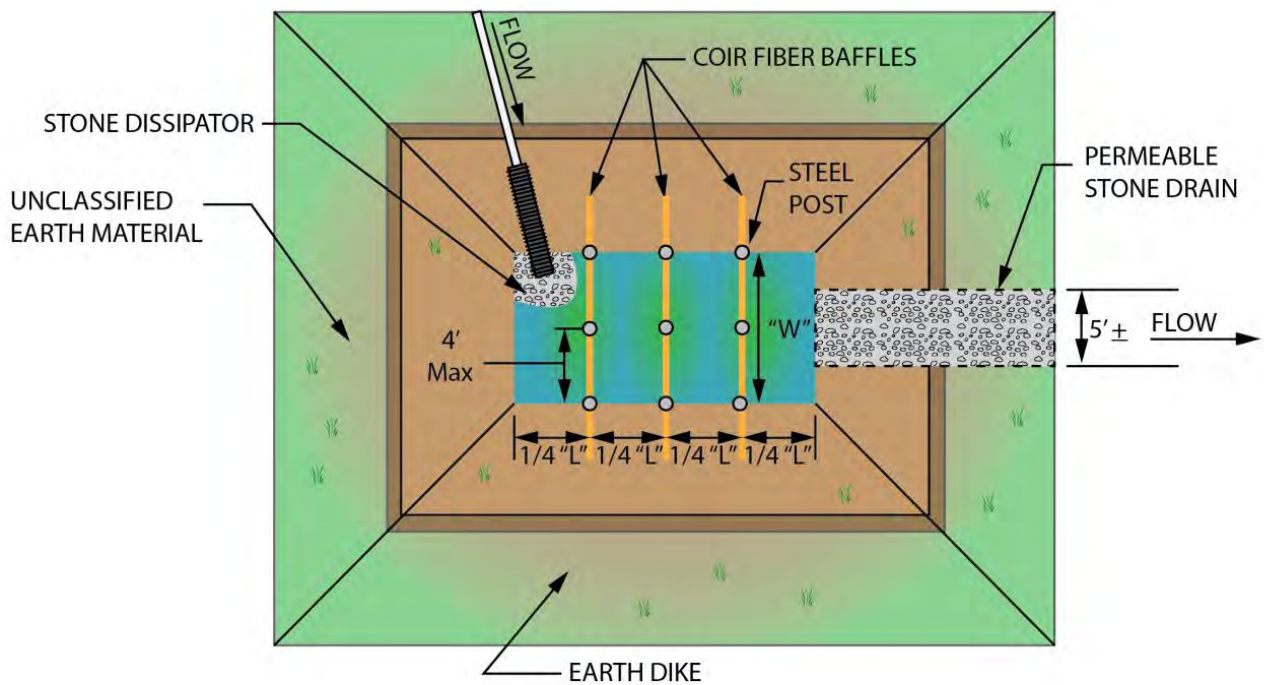

PLAN VIEW

## 4.8.3 Stilling Basin (1630.04)

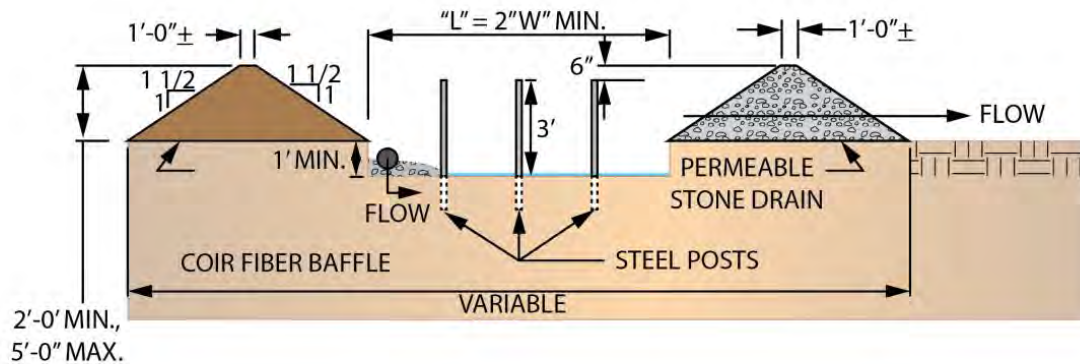

CROSS SECTION

### Material Specifications

- Unclassified earth material will be utilized for the embankments.
- Baffles shall meet the requirements of NCDOT's Standard Specifications Materials Section 1640-2.
- Stone to be utilized for permeable drain shall meet the requirements of Section 1042, Rip Rap Materials of NCDOT's Standard Specifications (see Table 1042-1, *Acceptance Criteria for Rip Rap and Stone for Erosion Control*).
- For all flocculant applications, follow the manufacturer's dosing instructions.

## 4.8.3 Stilling Basin (1630.04)



### Construction Specifications

<b>Basin</b>	<ul style="list-style-type: none"> <li>The height of the earthen dikes required for the stilling basin should not exceed 5 feet.</li> <li>The length to width ratio of the basin should be a minimum of 2:1.</li> <li>Non-vertical side slopes should be constructed and not greater than 1.5:1.</li> <li>The use of geotextile or other plastic lining may be utilized to prevent erosion and resuspension.</li> <li>A minimum of 1 foot below the bottom of the stone drain should be excavated.</li> </ul>
<b>Baffles</b>	<ul style="list-style-type: none"> <li>Install a minimum of 3 coir fiber baffles in the basin, with a spacing of <math>\frac{1}{4}</math> the basin length and in accordance with Section 1640 of the Standard Specifications.</li> </ul>
<b>Outlet</b>	<ul style="list-style-type: none"> <li>The Engineer shall approve the size stone for the permeable drain.</li> </ul>
<b>Flocculant</b>	<ul style="list-style-type: none"> <li>Prior to the flocculant application, obtain a soil sample from the project location, and analyze the sample for appropriate flocculant to be used for turbidity control.</li> <li>Use liquid or solid flocculant to reduce turbidity.</li> <li>Introduce liquid flocculant to the turbid water on the suction side of the pump while dewatering into the stilling basin.</li> <li>For solid flocculant use, discharge turbid water over a solid block of flocculant so the product can disperse into the stilling basin.</li> </ul>

### Technician's Checklist

- Place the basin on solid ground and construct as shown in the plans.
- Inspect the devices regularly and after significant rainfall.
- Tie the permeable stone drain into the dike. Use geotextile as necessary to keep the water from eroding under or around the stone.
- Install coir fiber baffles.
- Place the pump hose discharge as far as possible from the stone drain.
- Remove sediment as necessary to maintain effectiveness of the stilling basin. At a minimum, the basin should be cleaned out when it is 50% full of sediment.
- Check the basin often during the time that the pumps are running.
- Perform repairs immediately if any damage is identified within the basin or permeable drain.
- Maintain stabilization within the basin to prevent suspension of sediment. Discharge from large pumps can erode basin bottom.
- Never pump sediment-laden water directly into a stream.

**Locate the basin so that the treated water can reach the outfall easily without creating further erosion.**

## 4.8.3 Stilling Basin (1630.04)



### Measurement & Payment

#### Pay Items

Stilling Basin

Silt Excavation

#### Pay Units

Cubic Yard

Cubic Yard

### Maintenance

Maintenance of stilling basins is essential because water flow may become concentrated.

- Maintain the stilling basins, coir fiber baffles and remove and dispose of silt accumulations at the stilling basins in accordance with Section 1630 of NCDOT's Standard Specifications.
- Inspect the basin after each significant rainfall.
- At a minimum, clean out the basins when they are approximately 1/2 full.
- Stabilize earth embankment with temporary seed and mulch.
- Clean or replace stone for permeable outlet as needed.
- Inspect baffles after each day's use for erosion damage.
- Remove straw and other debris when needed.
- Remove the stilling basins as the project nears completion or at such time the Engineer deems the device is no longer useful. Prepare a seed bed and seed and mulch the area after removing the stilling basin in accordance with NCDOT Standard Specification Section 1660.

**The stilling basin needs to be cleaned prior to losing its effectiveness. These basins are usually removed when the area to be pumped is completed.**

### Typical Problems

- Basins are not constructed to the volume on the plans resulting in inadequate storage capacities.
- If the basin is constructed with vertical side slopes, increased sediment loss occurs in the basin from accelerated erosion of side slopes.
- Accumulated sediment is not removed when needed.
- The basin does not drain due to clogged stone on permeable drain.
- Effluent causes erosion as it exits the basin.
- Discharge from large pumps erodes the basin bottom causing suspended silt and sediments.
- Stone is not keyed into the natural ground allowing water to wash under the stone drain.

## 4.8.4 Special Stilling Basin (1630.06)



### Practical Tips

- The special stilling basin can be used to filter pumped water during construction of drilled piers, footing excavation or culvert construction.

### Definition

A special stilling basin is commonly used when the dewatering of a work area is necessary and construction of a stilling basin is not feasible. It is a bag made of a nonwoven geotextile lying on a bed of sediment control stone. As effluent from the work area is pumped into the special stilling basin, water is slowly filtered out through the walls of the bag, leaving sediment trapped inside.

### Areas of Use

Install special stilling basins in these locations:

- Where the excavation needed for construction of a stilling basin is not possible
- Where the effluent can be pumped out at a rate of 1,500 gallons per minute or less
- Where the construction activities will not require an extended period of time
- Around bridges with drilled pier construction where effluent will be pumped from the drilled shafts
- At outlets of Temporary Slope Drain pipes for sediment storage

**Plan ahead to utilize a method that will allow the special stilling basin to be removed safely from the work area.**

## 4.8.4 Special Stilling Basin (1630.06)

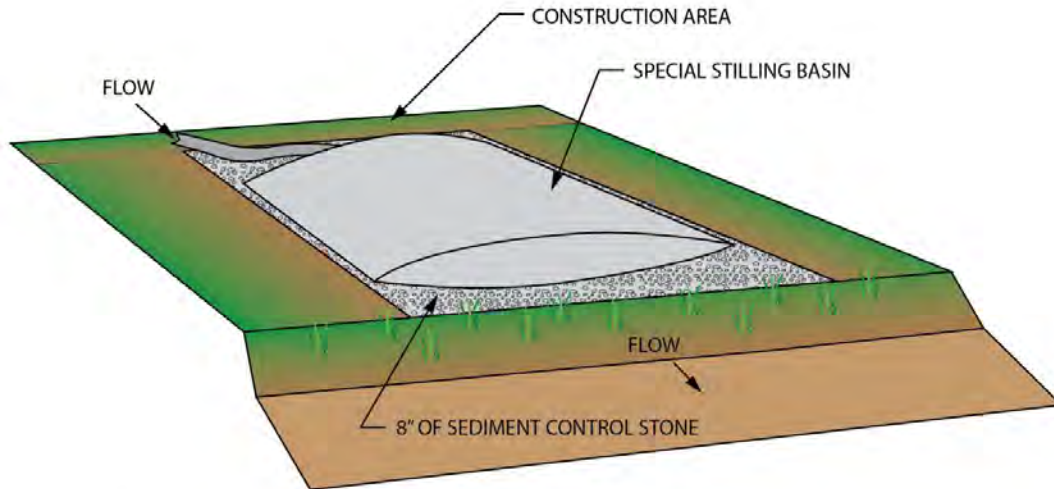

ISOMETRIC VIEW

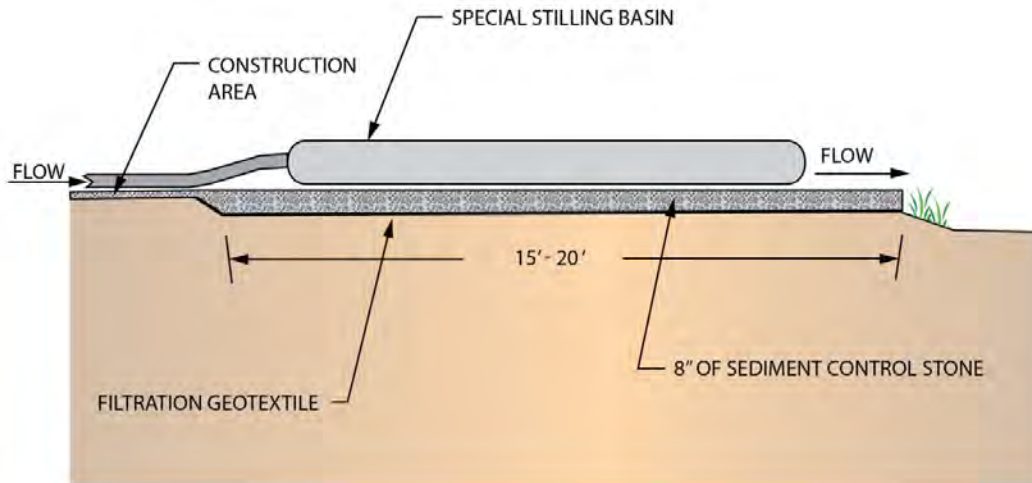

CROSS SECTION

## 4.8.4 Special Stilling Basin (1630.06)



### Material Specifications

- Use a water permeable geotextile bag that 1) is designed to handle the pump flow rate or drain pipe flow; and 2) traps sand, silt and fines as sediment-laden water enters the bag.
- Provide a special stilling basin bag constructed to a minimum size of 10 feet x 15 feet made from a nonwoven geotextile. The bag shall meet the requirements of Section 1060-15 of the Standard Specifications.
- Stabilize the bag to provide resistance to UV degradation as indicated in Table 1639-1, NCDOT Standard Specifications Section 1639.
- Use No. 5 or No. 57 sediment control stone that meets the requirements of Section 1005 of the Standard Specifications for these stone sizes.
- Provide geotextile under the stone that meets the requirements of Section 1056 of the Standard Specifications for Type 2 Geotextile.

### Construction Specifications

<p><b>Special Stilling Basin</b></p>	<ul style="list-style-type: none"> <li>• The bag shall be placed on a rock pad constructed of at least 8 inches of sediment control stone. The bag may also be placed on wooden pallets to elevate it above natural ground.</li> <li>• The rock pad should extend at least 1 foot past the bag on all sides.</li> <li>• The special stilling basin should be placed on level ground.</li> <li>• The bag should be installed in accordance with Section 1639 of the Standard Specifications.</li> <li>• The special stilling basin shall be placed so that incoming water flows into and through the bag without causing erosion.</li> <li>• Temporary slope drain pipe(s) or pump discharge hoses will be attached to the special stilling basin(s) so that water is routed directly into the special stilling basin(s).</li> <li>• The special stilling basin may be cut to allow slope drain pipe to be inserted if needed and tied off tightly. The remaining sleeve or spout of the bag, if present, may be used to connect more than one special stilling basin in series, as directed. If not used in this manner, the sleeve shall be tied off tightly to allow the bag to contain the effluent and force it to filter through the sides of the special stilling basin.</li> <li>• When being utilized in drilled pier construction, the special stilling basin should be constructed such that it is portable and can be used adjacent to each drilled pier.</li> </ul>
--------------------------------------	---------------------------------------------------------------------------------------------------------------------------------------------------------------------------------------------------------------------------------------------------------------------------------------------------------------------------------------------------------------------------------------------------------------------------------------------------------------------------------------------------------------------------------------------------------------------------------------------------------------------------------------------------------------------------------------------------------------------------------------------------------------------------------------------------------------------------------------------------------------------------------------------------------------------------------------------------------------------------------------------------------------------------------------------------------------------------------------------------------------------------------------------------------------------------------------------------------------------------------------------------------------------------------------------------------------------------------------------------------------------------------------------------------------------------------------------------------------------------------

## 4.8.4 Special Stilling Basin (1630.06)



### Technician's Checklist

- The permit should be checked for siting locations.
- Geotextile and stone or pallets should be used for the foundation.
- Special stilling basins must be inventoried and onsite.
- Special stilling basins should be a minimum of 10 feet x 15 feet.
- The discharge shall conform to permit requirements.
- A plan for removing full bags should be developed if one does not exist.

**In areas of special water quality concern, place the special stilling basin(s) up grade and direct its runoff into a sediment control measure before being allowed to discharge.**

### Measurement & Payment

#### Pay Items

Special Stilling Basin

Geotextile for Drainage

Sediment Control Stone

#### Pay Units

Each

Square Yard

Ton

### Maintenance

- The special stilling basin shall be disposed of and replaced when it is  $\frac{3}{4}$  full of sediment or when it is impractical for the bag to filter the sediment out at a reasonable flow rate.
- The inlet of the bag should be inspected periodically for damage and/or blockage.
- Sediment control stone shall be replaced if damaged by high flows or bag failure.

**Manage the pump's throttle to achieve maximum performance of the special stilling basin; flocculant use will aid in treating suspended clays.**

## 4.8.4 Special Stilling Basin (1630.06)



### Typical Problems

- Site conditions require too much flow to be pumped into the special stilling basin that causes the bag to rupture.
- The bag is not placed on level ground causing it to roll after water is pumped into it.
- Use continues when the bag is full.
- The spout becomes damaged or disconnected from the inlet pipe or hose.

## 4.8.4 Special Stilling Basin (1630.06)



*This page is intentionally left blank.*

# 4.9

## Section

### Soil Stabilization

Temporary Seeding	4.9.1
Temporary Mulching	4.9.2
Seeding and Mulching	4.9.3

This section provides guidance on stabilizing disturbed areas of a project site. As a construction project progresses, completed areas and areas of inactivity must be stabilized. NCDOT's NPDES permit has specific requirements and time frames that must be followed.

It is one of NCDOT's BMPs to stabilize areas as quickly as possible to avoid erosion problems that could overwhelm erosion and sediment control devices.

## 4.9.1 Temporary Seeding



### Definition

Temporary seeding is intended to be a supplement to, and not a substitute for, other means for the control of erosion and sedimentation. Temporary seeding should be used when no work will be done on an erodible area for a period that does not exceed the requirements in the current NPDES permit for an area that is not to final line and grade. Permanently seed and mulch the area if it will remain idle beyond the growing season for temporary seed mix species.

If the effort to obtain a stand of grass is not successful the first time, additional efforts must be made to protect the area. Soil tests are recommended if an area has to be seeded more than once.

### Areas of Use

Perform temporary seeding promptly under any of the following conditions as directed:

- When it is impossible or impractical to bring an area to the final line, grade and finish so that permanent seeding and mulching operations can be performed without subsequent serious disturbance by additional grading
- When erosion occurs or is considered to be potentially substantial on areas of graded roadbed where construction operations are temporarily suspended, or where the grading of the roadbed has been completed in advance of the paving construction
- During seasons of the year when permanent seeding and mulching is prohibited by the contract
- When an immediate cover would be desirable to minimize erosion, siltation or pollution on any area

### Practical Tips

- Do not use temporary seeding as stage seeding. As a fill or cut is being constructed, the slope should be placed on grade and permanently seeded when it is approximately 10 feet high.

## 4.9.1 Temporary Seeding

### Material Specifications

- Fertilizer must meet the requirements of Section 1060-2 of the Standard Specifications.
- Seed must meet the requirements of Section 1060-4 of the Standard Specifications.
- Mulch for erosion control must meet the requirements of Section 1060-5 of the Standard Specifications.
- The analysis of fertilizer and the type of seed will be as stated in the contract.

**The actual conditions of the site during the construction of the project will determine the quantity of seed or fertilizer to be used.**

### Construction Specifications

#### Seedbed Preparation

Specifications	<ul style="list-style-type: none"> <li>• Scarify areas to be seeded to a depth of not less than 5 inches unless directed otherwise. The soil conditions and topography will determine the required depth of the seedbed.</li> <li>• Prepare the surface to be seeded with adequate furrows, ridges, terraces, trenches or other irregularities in which seeding materials can lodge with reasonable assurance that the materials will not be easily displaced by wind, rain or surface runoff.</li> </ul>
----------------	-----------------------------------------------------------------------------------------------------------------------------------------------------------------------------------------------------------------------------------------------------------------------------------------------------------------------------------------------------------------------------------------------------------------------------------------------------------------------------------------------------------

#### Fertilizer and Seed Application

Specifications	<ul style="list-style-type: none"> <li>• The analysis of fertilizer, the type of seed and the rates of application of fertilizer and seed shall be as stated in the contract.</li> <li>• Do not apply fertilizer or seed if the Engineer determines conditions to be unfavorable for such operations.</li> <li>• Distribute the fertilizer or seed uniformly over the seedbed at the required rates of applications.</li> <li>• Cover fertilizer and seed unless otherwise directed. If covering is required, provide it to the depth acceptable to the Engineer for the prevention of displacement by wind, rain or surface runoff.</li> <li>• Mulch all areas temporarily seeded, in accordance with Standard Specifications Section 1615, unless otherwise indicated in the contract or as directed.</li> <li>• Standard Specifications Article 1660-5 governs the approval of equipment and the protection of traffic, structures, guardrails, traffic control devices and other appurtenances.</li> </ul>
----------------	----------------------------------------------------------------------------------------------------------------------------------------------------------------------------------------------------------------------------------------------------------------------------------------------------------------------------------------------------------------------------------------------------------------------------------------------------------------------------------------------------------------------------------------------------------------------------------------------------------------------------------------------------------------------------------------------------------------------------------------------------------------------------------------------------------------------------------------------------------------------------------------------------------------------------------------------------------------------------------------------------------------

## 4.9.1 Temporary Seeding

### Technician's Checklist

- Permanently seed and mulch the area in lieu of temporary seeding, if possible.
- Advise the Contractor whether the temporary seeding that has been requested will be at contract unit price or at the Contractor's expense due to negligence in performing continuous grading.
- Provide ground cover to any exposed erodible slope that has remained ungraded for more than the number of days allowed in the latest NPDES permit.
- Establish a 5-inch seedbed.

**Every effort must be made to obtain a proper seedbed. On solid undisturbed earth, the seedbed depth should be approximately 5 inches.**

### Measurement & Payment

- Seed for Temporary Seeding will be measured and paid in pounds. The weight of seed will be determined by bag count of standard weight bags or by weighing the seed.
- Fertilizer for Temporary Seeding will be measured and paid in tons. The weight of dry fertilizer will be determined by bag count of standard weight bags or by weighing the fertilizer in trucks on certified platform scales or other certified weighing devices.
- Temporary Mulching will be measured and paid in accordance with Standard Specifications Section 1615.
- Mowing will be measured and paid in accordance with Standard Specifications Article 1660-8. Where earthwork and temporary seeding have been adequately constructed, completely drained and properly maintained and damage occurs due to natural causes, the Contractor will be paid at the contract unit prices for applicable items (the excavated material required for repairs to the damaged earthwork, Seed for Temporary Seeding and Fertilizer for Temporary Seeding) for correcting the damaged temporary seeding.
- Repairs shall be made, at no cost to the Department, to any damage to earthwork or temporary seeding which is due to carelessness or neglect on the part of the Contractor.

### Pay Items

### Pay Units

Seed for Temporary Seeding

Pounds

Fertilizer for Temporary Seeding

Tons

Temporary Mulching

Acres

## 4.9.1 Temporary Seeding

### Maintenance

- Maintain areas where temporary seeding is performed in a satisfactory condition (including mowing) at the locations and times as directed.
- Repair areas of temporary seeding which have been damaged or have failed. Repair includes reshaping or the placing of additional earth material and repeating the seeding process.

## 4.9.1 Temporary Seeding

*This page is intentionally left blank.*

## 4.9.2 Temporary Mulching



### Definition

Use temporary mulch to cover temporary seeding or bare ground. Temporary mulch is not intended as a long-term ground cover. If the area to be covered will remain undisturbed for more than 30 days, temporary seeding is recommended with temporary mulch.

Temporary mulch works by impeding the flow of water over the area, conserving moisture, providing shade and absorbing the impact of the rain drops. Mulch provides the benefit of holding the soil together as it is incorporated during the seed bed preparation for permanent seeding and mulching.

### Areas of Use

- During construction operations where it is impossible or impractical to perform permanent seeding and mulching

### Material Specifications

- Mulch for erosion control must meet the requirements of Section 1060-5 of the Standard Specifications.
- In High Quality Waters (HQW), use an approved hydraulically applied binding agent.

### Practical Tips

- Mulch can be displaced by traffic, wind and rain. As soon as the mulch is placed, cover it with sufficient binding material to maximize retention of mulch.
- Exposed erodible slopes must not remain bare longer than allowed by the current NPDES permit.

**In High Quality Water zones, which will be designated on the plans, asphalt is not recommended as a binding agent.**

## 4.9.2 Temporary Mulching

### Construction Specifications

<b>Uniform Cover</b>	<ul style="list-style-type: none"> <li>• Spread mulch uniformly over the area by hand or by means of appropriate mechanical spreaders or blowers to obtain a satisfactory uniform cover.             <ul style="list-style-type: none"> <li>○ A satisfactory application of temporary mulch on non-seeded areas consists of a sufficient amount to completely and uniformly cover the ground.</li> <li>○ When temporary mulching is performed in conjunction with temporary seeding, apply mulch in accordance with Standard Specifications Article 1660-6. Complete mulching and tacking within 24 hours of temporary seeding work. Exercise care to prevent displacement of soil and seed or other damage to areas of temporary seeding.</li> </ul> </li> </ul>
<b>Binding Agent</b>	<ul style="list-style-type: none"> <li>• Apply a sufficient amount of asphalt or other binding material when using grain straw to assure that the temporary mulch is properly held in place.             <ul style="list-style-type: none"> <li>○ Take adequate precautions to prevent hazards to traffic and damage to structures, guardrails, traffic control devices or any other appurtenances during the application of binding material. Provide adequate covering or change methods of application as required to prevent such damage. Repair any damage that occurs, including any necessary cleaning.</li> </ul> </li> </ul>

### Technician's Checklist

- Visually check coverage at the beginning of the operation so that adjustments can be made if necessary (2 tons/acre, 75% complete coverage, and no ground visible 10 feet ahead).
- Ask "Is the area in a **High Quality Water zone?**" It is recommended that the asphalt not be used in HQW zones unless approved by the Roadside Environmental Field Operations Engineer.
- Inspect the area to confirm that the proper binding agent is on site with the proper application equipment.
- Check the rate of binding agent application to confirm that it will serve its intended purpose.
- Check the Project Special Provisions to determine if crimping is required.

**Great care should be used not to create ruts or to disturb the slope during the mulching or binder placement operations.**

## 4.9.2 Temporary Mulching

### Measurement & Payment

- Temporary Mulching will be measured and paid in acres, measured along the surface of the ground over which temporary mulch has been placed as directed and accepted.

Pay Items	Pay Units
Temporary Mulching	Acres

### Maintenance

- At the time that seeding and/or mulching is being performed, temporary erosion and sediment control devices are normally in place. These devices lose their effectiveness when they are clogged with mulch. All mulch must be removed from these devices as soon as possible.
- Take sufficient precautions to prevent mulch from entering drainage structures through displacement by wind, water or other causes and promptly remove any blockage of drainage facilities.

## 4.9.2 Temporary Mulching

*This page is intentionally left blank.*

## 4.9.3 Seeding and Mulching



### Definition

Seeding and mulching should be performed on all earth areas disturbed by construction and, as directed, where areas seeded under previous contracts have unsatisfactory vegetative cover.

Seeding and mulching are to be immediately performed on any area brought to line and grade, provided it is within a specified seasonal limitation for seeding and mulching, rather than waiting for the major portion of the project to be completed.

When seeding and mulching, the required line, grade and cross section of the area treated should be preserved.

### Areas of Use

- Where the permanent establishment of vegetation from seed is needed on shoulders, slopes, ditches, borrow pits or other roadside areas

### Practical Tips

- Adapt operation as needed for variations in weather or soil conditions to maximize the successful establishment of grasses or legumes.
- Mowing at the proper time is of great importance in the establishment of a permanent vegetative cover.

**There is no difference between the methods and materials used to seed and mulch borrow pits and waste areas and those required for the roadway itself.**

## 4.9.3 Seeding and Mulching

### Coordination with Grading Operations

- Perform seeding and mulching operations on a section-by-section basis immediately upon completion of earthwork sections in accordance with the 2012 NCDOT Standard Specifications Article 225-2.

**The contract will state the seasonal limitations for seeding operations, fertilizer specifications, seed specifications and the rates of application of limestone, fertilizer and seed.**

### Material Specifications

- Fertilizer must meet the requirements of Section 1060-2 of the Standard Specifications.
- Limestone must meet the requirements of Section 1060-3 of the Standard Specifications.
- Seed must meet the requirements of Section 1060-4 of the Standard Specifications.
- Mulch for erosion control must meet the requirements of Section 1060-5 of the Standard Specifications.
- Undiluted emulsified asphalt should be used for tacking material. In High Quality Water zones (these will be designated on the plans) asphalt is not desired as a binding agent. These areas are in close proximity to important waters and the asphalt runoff may endanger the fish population.
- The analysis of fertilizer and the type of seed will be as stated in the contract.

## 4.9.3 Seeding and Mulching

### Construction Specifications

#### Seedbed Preparation

<p><b>Specifications</b></p>	<ul style="list-style-type: none"> <li>• Cut and satisfactorily dispose of weeds or other unacceptable growth on the areas to be seeded.</li> <li>• Shape and smooth uneven and rough areas outside of the graded section, such as crop rows, farm contours, ditches and ditch spoil banks, fence line and hedgerow soil accumulations and other minor irregularities which cannot be obliterated by normal seedbed preparation operations, to provide for more effective seeding and for ease of subsequent mowing operations.</li> <li>• Scarify or otherwise loosen the soil to a depth of not less than 5 inches except as otherwise provided below or otherwise directed.</li> <li>• Break clods and work the top 2 to 3 inches of soil into an acceptable seedbed using soil pulverizers, drags or harrows or other approved methods.</li> <li>• Remove all rock and debris 3 inches or larger on median, shoulder and ditch cut or fill slopes which are 3:1 or flatter, before the application of seed and fertilizer. Remove rock 6 inches and larger displaced during seeding operations.</li> <li>• Scarify, groove, trench or puncture all slope surfaces. The depth of preparation and the degree of smoothness of the seedbed may be reduced on cut slopes that are 2:1 and steeper, as permitted by the Engineer.</li> <li>• On cut slopes that are either 2:1 or steeper, the Engineer may permit the preparation of a partial or complete seedbed during the grading of the slope. If, at the time of seeding and mulching operations, such preparation is still in a condition acceptable to the Engineer, additional seedbed preparation may be reduced or eliminated.</li> <li>• Limit seedbed preparation to a depth of 2 to 3 inches for areas within 2 feet of the edge of the pavement.</li> <li>• Do not prepare the seedbed when the soil is frozen, extremely wet or when the Engineer determines that it is an otherwise unfavorable working condition.</li> </ul>
------------------------------	------------------------------------------------------------------------------------------------------------------------------------------------------------------------------------------------------------------------------------------------------------------------------------------------------------------------------------------------------------------------------------------------------------------------------------------------------------------------------------------------------------------------------------------------------------------------------------------------------------------------------------------------------------------------------------------------------------------------------------------------------------------------------------------------------------------------------------------------------------------------------------------------------------------------------------------------------------------------------------------------------------------------------------------------------------------------------------------------------------------------------------------------------------------------------------------------------------------------------------------------------------------------------------------------------------------------------------------------------------------------------------------------------------------------------------------------------------------------------------------------------------------------------------------------------------------------------------------------------------------------------------------------------------------------------------------------------------------------------------------------------------------------------------------------------------------------------------------------------------------------------------------------------------------------------------------------------------------------------------------------

## 4.9.3 Seeding and Mulching

### Limestone, Fertilizer and Seed Application

<b>General Specifications</b>	<ul style="list-style-type: none"> <li>• Apply limestone, fertilizer and seed within 24 hours after completion of seedbed preparation unless otherwise permitted by the Engineer.</li> <li>• When the Engineer determines that weather and soil conditions are unfavorable, do not distribute any limestone or fertilizer and do not sow any seed.</li> <li>• Take adequate precautions to prevent hazards to traffic and damage to structures, guardrails, traffic control devices or any other appurtenances during the application of fertilizer. Provide adequate covering or change methods of application as required to avoid such damage.</li> <li>• Repair any damage that occurs, including any cleaning that may be necessary.</li> </ul>
<b>Limestone and Fertilizer</b>	<ul style="list-style-type: none"> <li>• Limestone may be applied as a part of the seedbed preparation, provided it is immediately worked into the soil. If not so applied, distribute limestone and fertilizer uniformly over the prepared seedbed at the specified rate of application and then harrow, rake or otherwise thoroughly work or mix into the seedbed.</li> </ul>
<b>Seed</b>	<ul style="list-style-type: none"> <li>• Distribute seed uniformly over the seedbed at the required rate of application, and immediately harrow, drag, rake or otherwise work so as to cover the seed with a layer of soil. Cover to a depth as directed by the Engineer. If two kinds of seed are to be used that require different depths of covering, sow separately.</li> <li>• When a combination seed and fertilizer drill is used, drill fertilizer with seed after applying and incorporating limestone into the soil. If using two kinds of seed requiring different depths of cover, the seed requiring the lighter cover may be sown broadcast, with a special attachment to the drill, or drilled lightly following the initial drilling operation.</li> <li>• When using a hydraulic seeder for application of seed and fertilizer, do not allow the seed to remain in water containing fertilizer for more than 30 minutes before application unless otherwise permitted.</li> <li>• Compact the seedbed immediately after seed has been properly covered in a manner and degree approved by the Engineer.</li> </ul>

## 4.9.3 Seeding and Mulching

### Modifications

- When adverse seeding conditions are encountered due to steepness of slope, height of slope or soil conditions, the Engineer may direct or permit that modifications be made to the requirements previously presented regarding:
  - Incorporating limestone into the seedbed
  - Covering limestone, seed and fertilizer
  - Compacting the seedbed
- Such modifications may include but not be limited to the following:
  - The incorporation of limestone into the seedbed may be omitted as follows:
    - On cut slopes steeper than 2:1
    - On 2:1 cut slopes when a seedbed has been prepared during the excavation of the cut and is still in an acceptable condition
    - On areas of slopes where the surface of the area is too rocky to permit the incorporation of the limestone
  - The rates of application of limestone, fertilizer and seed on slopes 2:1 or steeper or on rocky surfaces may be reduced or eliminated.
  - Compaction after seeding may be reduced or eliminated on slopes 2:1 or steeper, on rocky surfaces or on other areas where soil conditions would make compaction undesirable.

### Technician's Checklist

- Finish earthwork to line and grade.
- Vegetate exposed erodible slopes within the time required in the latest NPDES permit.
- Check project special provisions for areas of the project to be given a lawn type appearance.
- All seed on the project must be approved for use.
- Meet the specifications for limestone and fertilizer.
- Periodically sample the limestone used by the Contractor to see that it conforms to NCDOT specifications.
- Properly store and protect the materials from the elements.
- Apply the mulch material at the rate of 2 tons per acre.
- Measure the area to be seeded for payment and to verify application rate.
- Seedbed shall be in a loose condition prior to seeding.
- Apply materials uniformly at the specified rates and properly incorporate into the soil.
- Remove rocks and other debris prior to the mulching operations.
- The Contractor shall properly coordinate the work: seeding soon after the seedbed is prepared, cultipacking immediately after the seeding is done, mulching soon after the cultipacking and applying the tacking material immediately.
- Use a sufficient amount of tack to tie down the mulch.

**Obtain approval from the Engineer before using equipment for the application, covering or compaction of limestone, fertilizer and seed.**

## 4.9.3 Seeding and Mulching

### Measurement & Payment

Seeding and Mulching will be measured and paid in acres according to Standard Specifications Section 1660-8, measured along the surface of the ground completed and accepted. No direct payment will be made for furnishing and applying the limestone and fertilizer as such work and materials will be incidental to the work covered by Seeding and Mulching.

### Pay Items

Seeding and Mulching

### Pay Units

Acres

### Maintenance

- Where vegetation is damaged or fails to successfully establish, repair in accordance with this section.
- Maintain areas seeded and mulched in a continuous manner, as directed by the Technician, rather than waiting to repair all damaged areas at one time near the end of the project.
- Conduct maintenance including mowing, repair seeding, topdressing or complete reseeding, if required. A pay item for each of these functions is included in the Standard Specifications.
- If maintenance is needed due to negligence or damage by the Contractor, there will be no pay for the repairs.

Consult the Roadside Environmental Field Operations Engineer regarding any questions concerning maintenance of seeding and mulching.