



Vehicle Damage Scale for Traffic Accident Investigators



Published by



***National
Safety
Council***

1121 Spring Lake Drive
Itasca, Illinois 60143



Revised with the assistance of
UNIVERSITY OF
NORTH CAROLINA

**Highway Safety
Research Center**

Chapel Hill, North Carolina 27514



Purpose

Purpose of this manual is to aid investigators in assessing damage sustained by motor vehicles in traffic accidents. By means of a relatively simple procedure, most common types of damage can be rated in terms of a 7-point severity scale.

Basically, the vehicle damage scale consists of several pages of photographs of automobiles damaged in accidents. There is a separate page for each of the common impacts that investigators are likely to encounter. In order to rate damage on a vehicle, the user must select the proper page of photographs, and then attempt to match the damage on the subject vehicle with one of the photographs appearing on the page.

In the upper left corner of each page facing a photo page, there is a small diagram of a car and an arrow, or series of arrows, showing direction of the principal impact force. In addition to the diagram, there is a symbol (FC, for example) which indicates the part of the vehicle damaged and type of impact. The symbol is repeated in the upper right corner of the photo page. The diagrams and symbols which identify each page also appear in an index designed to assist in finding the proper page.

On each of the pages in the damage rating section of this appendix, there are 3 photographs, or 3 two-view sets of photographs, showing automobiles damaged in traffic accidents. Numerals on the left page opposite the photographs and intervening spaces are used for indicating severity of damage.

Damage in the top photographs, or sets of photographs, is minor and is generally limited to dents and gouges in body sheet metal and trim. The damage rating corresponding to these photographs is "2".

The second photographs, or sets of photographs, show automobiles that have been moderately damaged, with considerable crumpling of body sheet metal, but little or no distortion of the basic structure or frame. The damage rating in this case is "4".

In the photographs at the bottom of each sheet, vehicles are severely, but not totally damaged. Sheet metal is severely distorted, torn, or crumpled; the basic structure of the car is distorted somewhat; and there is usually some penetration of the passenger compartment. The damage rating is "6".

The reason for the "2, 4 and 6" rating is that an investigator may not be able to match damage on the vehicle on which he is reporting with any of the photographs. In that case, he may use "1, 3, 5 or 7" ratings for damage less or greater than shown in the photographs. Thus with the 3 photographs, he should be able to select any one of seven degrees of severity to describe how badly a car was damaged.

How to Use Scale

In order to make a damage rating, the investigator must first select the proper page of pictures. The selection will be determined by the type of collision. For example, if he is reporting on an angle collision which occurred at an intersection, and the front end of a vehicle struck another vehicle on its left side, he must refer to the Index to Damage Scale and find the diagram that most nearly describes the impact on the first vehicle. In this case, it may be the diagram which shows distributed impact on the front end. In the column headed, "Use Scale," the symbol "FD" tells the investigator what page of pictures should be used in making the damage rating. For convenience, the pages are arranged in the same order as their designators appear in the index.

The next step is to compare the damage on the vehicle with the photograph on the selected page. If, for example, the front end damage of the first vehicle appears to match that of the bottom photograph on page FD, the damage rating would be "6". The entry in the accident report form would then be FD-6. However, if the damage were more severe, the rating would be FD-7; and, if less severe, but greater than a "4", it would be FD-5.

The procedure for rating the damage on the car that was struck on its left side is similar, except that the investigator must determine what part of the left side was struck before he can select the proper page of photographs. Impact diagrams in the index facilitate this determination.

If the vehicle were struck broadside in the area of the passenger compartment, the investigator would use the page headed LP/RP for the damage rating. However, if the impact occurred in the area ahead of the passenger compartment, the page headed LFO/RFO (left front quarter/right front quarter) would be proper to use; and, if the impact occurred behind the passenger compartment, the LBO/RBO (left back quarter/right back quarter) would be used.

Should the investigator decide that the second car in the example collision was struck broadside in the area of the passenger compartment, his entry in the accident report form would be LP- (with appropriate numeral). If the second car were struck on the right side, instead of the left side, the investigator would use the LP/RP page, but his entry in the accident report form would be RP- (with appropriate numeral).

Dual designations such as LP/RP, LBO/RBO, FL/FR and BL/BR mean that the pages so labeled may be used for either left or right sides of vehicle to be rated. The investigator should exercise care in writing the rating so that there will be no question as to what side or corner was damaged.

In cases in which vehicles are damaged in more than one area, the investigator should enter the rating of each damaged area, starting with the severest damage. e.g., FD-6, BD-3, LD-2. If a vehicle sustained no discernable damage, a "0" (zero) rating with appropriate prefix should be used; e.g., FD-0, FL-0, etc. Such ratings are usually applicable to collisions of motor vehicles with pedestrians or bicycles or to non-collision accidents.

In the case of trucks and buses, the investigator should be able to make satisfactory ratings on damage to the front end, front quarter, and side impacts in the vicinity of the driver compartment. However, in the case of impacts in other parts of the vehicle, he may rate the damage without pictures to help if he applies the principles established for passenger cars.

Direction of Force

A rough indication of the direction of force is provided by the letter code in the Vehicle Damage Scale. However, for those users who may wish a more precise scheme for indicating direction of force, an imaginary circle might be superimposed around the vehicle as indicated by the following sketch:

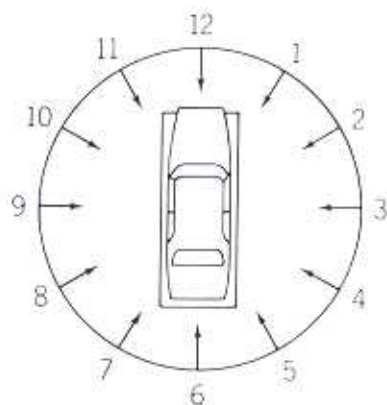

FIGURE 1

Any of the above numbers that is used should precede the letter code to prevent any confusion with the numerical severity code which follows the letter code. Inclusion of direction of force codes are shown in the following examples: 12-FC-3; 9-LP-2; 6-BD-4.

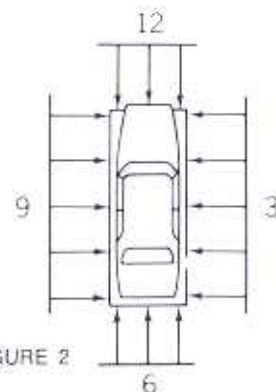

FIGURE 2

In Figure 2 above, the direction of force codes indicated by numbers 3, 6, 9 and 12 are approximately perpendicular to the vehicle. Compatible direction of force codes and letter codes are:

12-FC	3-RBQ	6-BC	9-LBQ
12-FD	3-RFQ	6-BD	9-LFQ
12-FL	3-RP	6-BL	9-LP
12-FR	3-R&T	6-BR	9-L&T

Any other letter code combined with any of the above numbered codes should be considered as incompatible.

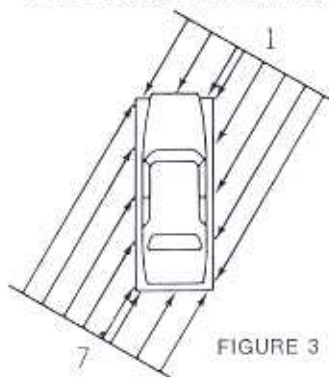

FIGURE 3

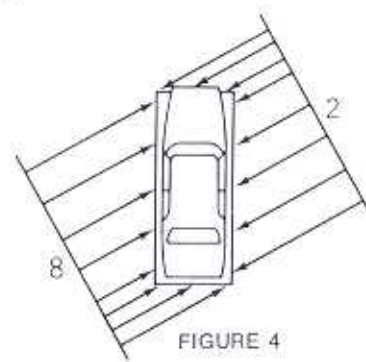

FIGURE 4

In Figure 3, the direction of force codes indicated by numbers 1 and 7 are isolated. In Figure 4, the direction of force codes indicated by numbers 2 and 8 are isolated. Below are combinations of compatible codes

1-FC	2-FC	7-BC	8-BC
1-FL	2-FL	7-BL	8-BL
1-FR	2-FR	7-BR	8-BR
1-RBQ	2-RBQ	7-LBQ	8-LBQ
1-RFQ	2-RFQ	7-LFQ	8-LFQ
1-RD	2-RP	7-LD	8-LP
1-RP		7-LP	

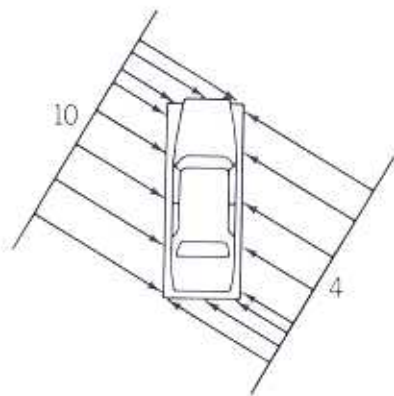

FIGURE 5

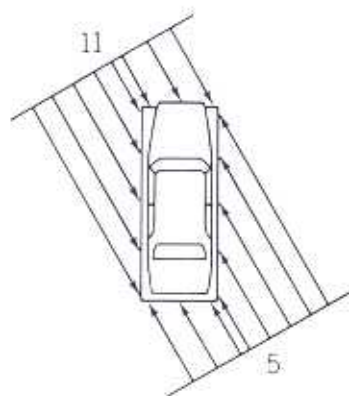

FIGURE 6

In Figure 5, the direction of force codes indicated by numbers 4 and 10 are isolated. In Figure 6, the direction of force codes indicated by numbers 5 and 11 are isolated. Below are combinations of compatible codes:

4-RBQ	5-RBQ	10-LBQ	11-LBQ
4-RFQ	5-RFQ	10-LFQ	11-LFQ
4-RP	5-RD	10-LP	11-LD
4-BL	5-RP	10-FC	11-LP
4-BR	5-BL	10-FL	11-FC
4-BC	5-BR	10-FR	11-FL
	5-BC		11-FR

INDEX TO DAMAGE SCALE



1. Front or Rear End Damage

	Type of Impact	Use Scale	Write
	Front end damage due to concentrated impact resulting from collision of subject vehicle with tree, utility pole, or other narrow object.	FC	FC-___
	Front end damage due to distributed impact resulting from full contact of front end of subject vehicle with other vehicle or broad object.	FD	FD-___
	Front left corner damage due to partial contact of front end of subject vehicle with other vehicle or object.	FL/FR	FL-___
	Front right corner damage due to partial contact of front end of subject vehicle with other vehicle or object.	FL/FR	FR-___
	Rear end damage due to concentrated impact resulting from collision of subject vehicle with tree, utility pole, or other narrow object.	BC	BC-___
	Rear end damage due to distributed impact resulting from full contact of rear end of subject vehicle with another vehicle or object. Applicable to rear-end collisions.	BD	BD-___
	Rear left corner damage due to partial contact of rear end of subject vehicle with another vehicle or object. Applicable to rear-end collisions.	BL/BR	BL-___
	Rear right corner damage due to partial contact of rear end of subject vehicle with another vehicle or object. Applicable to rear-end collisions.	BL/BR	BR-___

INDEX TO DAMAGE SCALE

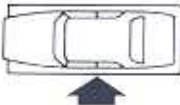
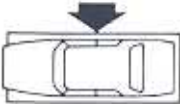
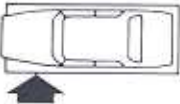
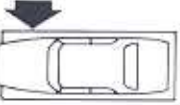
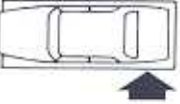
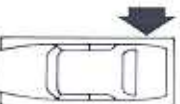
2. Side and/or Top Damage

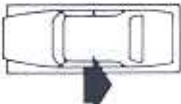
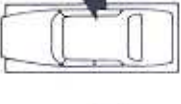
	Type of Impact	Use Scale	Write
	<i>Left side</i> damage in vicinity of passenger compartment due to <i>angular impact</i> by another vehicle or object. Applicable to angle collisions and accidents in which a vehicle strikes an object after skidding or spinning.	LP/RP	LP-___
	<i>Right side</i> damage in vicinity of passenger compartment due to <i>angular impact</i> by another vehicle or object.	LP/RP	RP-___
	<i>Left front quarter</i> damage (ahead of passenger compartment) due to <i>angular impact</i> by another vehicle or object. Applicable to angle collisions and accidents in which a vehicle strikes an object after skidding or spinning.	LFQ/RFQ	LFQ-___
	<i>Right front quarter</i> damage (ahead of passenger compartment) due to <i>angular impact</i> by another vehicle or object.	LFQ/RFQ	RFQ-___
	<i>Left rear quarter</i> damage (behind passenger compartment) due to <i>angular impact</i> by another vehicle or object. Applicable to angle collisions and accidents in which a vehicle strikes an object after skidding or spinning.	LBQ/RBQ	LBQ-___
	<i>Right rear quarter</i> damage (behind passenger compartment) due to <i>angular impact</i> by another vehicle or object.	LBQ/RBQ	RBQ-___

	Type of Impact	Use Scale	Write
	<i>Left side</i> damage resulting from sideswipe by meeting or overtaking other vehicle or object.	LD/RD	LD-___
	<i>Right side</i> damage resulting from sideswipe by meeting or overtaking other vehicle or object.	LD/RD	RD-___
	<i>Left side and top</i> damage due to roll-over.	L&T/R&T	L&T-___
	<i>Right side and top</i> damage due to roll-over.	L&T/R&T	R&T-___

SEVERITY SCALE

FC

Front End Damage
Concentrated Impact

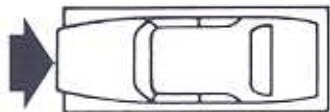

This scale is applicable to damage to the front of subject vehicle resulting from a collision with a tree, utility pole or other narrow object.

Damage Rating

FC-1



FC-2



FC-3



FC-4



FC-5



FC-6



FC-7



SEVERITY SCALE

FD

Front End Damage
Distributed Impact

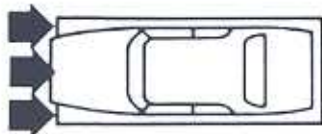

This scale is applicable to damage to front of subject vehicle due to distributed impact resulting from full contact with other vehicle or broad object.

Damage Rating

FD-1 



FD-2 



FD-3 



FD-4 



FD-5 



FD-6 



FD-7 

FD

SEVERITY SCALE

FL/FR

Front End Damage
Partial Contact

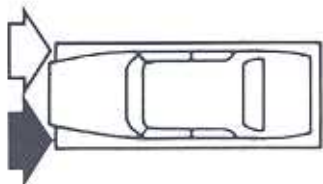

This scale is applicable to damage resulting from partial contact of front end (left front corner or right front corner) of subject vehicle with another vehicle or object.

Damage Rating

FL-1 or FR-1



FL-2 or FR-2



FL-3 or FR-3



FL-4 or FR-4



FL-5 or FR-5



FL-6 or FR-6



FL-7 or FR-7



FL/FR

SEVERITY SCALE



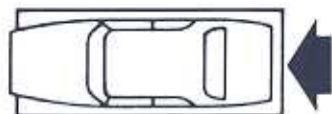

BC

Back End Damage
Concentrated Impact



This scale is applicable to damage to the back end of subject vehicle resulting from a collision with a tree, utility pole or other narrow object.

Damage Rating

BC-1 BC-2 BC-3 BC-4 BC-5 BC-6 BC-7 

SEVERITY SCALE

BD

Rear End Damage
Distributed Impact

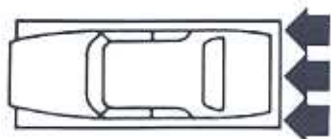

This scale is applicable to damage to rear of subject vehicle resulting from full contact of rear end of subject vehicle with other vehicle or object.

Damage Rating

BD-1 →



BD-2 →

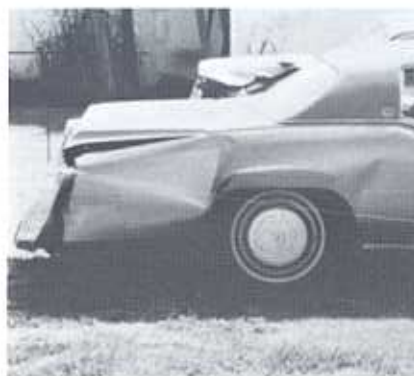

BD-3 →

BD-4 →



BD-5 →

BD-6 →



BD-7 →

BD

SEVERITY SCALE
BL/BR

Rear End Damage
Partial Contact

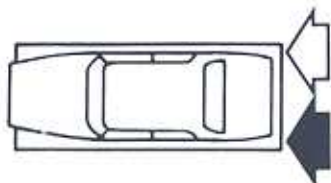

This scale is applicable to damage resulting from partial contact of rear end (left rear corner or right rear corner) of subject vehicle with another vehicle or object.

Damage Rating

BL-1 or BR-1 



BL/BR

BL-2 or BR-2 



BL-3 or BR-3 

BL-4 or BR-4 

BL-5 or BR-5 

BL-6 or BR-6 

BL-7 or BR-7 



SEVERITY SCALE

LP/RP

Side Damage
Angular Impact

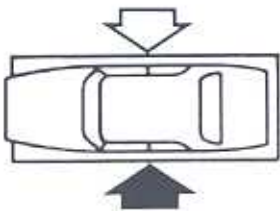

This scale is applicable to damage to side in the vicinity of the passenger compartment of subject vehicle resulting from an angular impact by another vehicle or object.

Damage Rating

LP-1 or RP-1 LP-2 or RP-2 LP-3 or RP-3 LP-4 or RP-4 LP-5 or RP-5 LP-6 or RP-6 LP-7 or RP-7 

SEVERITY SCALE

LFQ/RFQ

Front Quarter Damage
Angular Impact

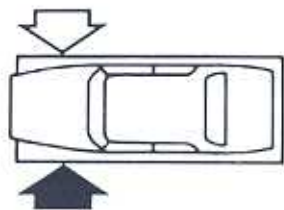

This scale is applicable to damage to the left or right front quarter of subject vehicle (ahead of passenger compartment) resulting from an angular impact, by another vehicle or object.

Damage Rating

LFQ-1 or RFQ-1 ➔

LFQ-2 or RFQ-2 ➔

LFQ-3 or RFQ-3 ➔

LFQ-4 or RFQ-4 ➔

LFQ-5 or RFQ-5 ➔

LFQ-6 or RFQ-6 ➔

LFQ-7 or RFQ-7 ➔

LFQ/RFQ



SEVERITY SCALE

LBQ/RBQ

Rear Quarter Damage
Angular Impact

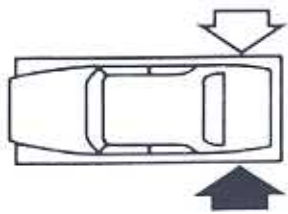

This scale is applicable to damage to the left or right rear quarter of subject vehicle (behind passenger compartment) resulting from an angular impact by another vehicle or object.

Damage Rating

LBQ-1 or RBQ-1 ➔



LBQ-2 or RBQ-2 ➔



LBQ-3 or RBQ-3 ➔

LBQ-4 or RBQ-4 ➔

LBQ-5 or RBQ-5 ➔

LBQ-6 or RBQ-6 ➔

LBQ-7 or RBQ-7 ➔



LBQ/RBQ

SEVERITY SCALE

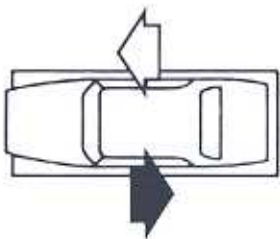

LD/RD

Distributed Side Damage
Parallel Impact



This scale is applicable to damage to the left or right side of subject vehicle resulting from a sideswipe with another vehicle or object.

Damage Rating

LD-1 or RD-1 LD-2 or RD-2 LD-3 or RD-3 LD-4 or RD-4 LD-5 or RD-5 LD-6 or RD-6 LD-7 or RD-7 

SEVERITY SCALE

L&T/R&T

Side and Top Damage
Roll-over Effects

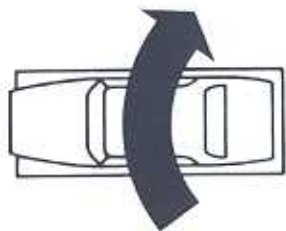

This scale is applicable to damage to left or right side and top of subject vehicle resulting from a roll-over.

Damage Rating

L&T-1 or R&T-1 →

L&T-2 or R&T-2 →

L&T-3 or R&T-3 →

L&T-4 or R&T-4 →

L&T-5 or R&T-5 →

L&T-6 or R&T-6 →

L&T-7 or R&T-7 →

L&T/R&T



APPENDIX I

The Manual on Classification of Motor Vehicle Traffic Accidents, Fourth Edition (ANSI D 16.1-1983) provides a minimal vehicle damage classification scheme which is intended for use by those jurisdictions that may not presently be in a position to implement the more refined "Vehicle Damage Scale".

Four mutually exclusive categories listed in ANSI D16.1-1983 for classifying vehicle damage only are: (1) disabling damage, (2) functional damage, (3) other motor vehicle damage, and (4) no damage. Each of these categories is explained in detail in the above mentioned publication.

APPENDIX II

No damage to a vehicle may be of interest to many researchers and can be indicated by a zero code (0). For example, if two motor vehicles collide head-on and one motor vehicle sustains no damage, the complete vehicle damage code (including direction of force) for the undamaged vehicle may be indicated by 12-FD-0.

Although the information and recommendations contained in this publication have been compiled from sources believed to be reliable, the National Safety Council makes no guarantee as to, and assumes no responsibility for, the correctness, sufficiency or completeness of such information or recommendations. Other or additional safety measures may be required under particular circumstances.
