

Note:
 1. Opening in pole base plate shall be equal to pole base inside diameter minus 3 1/2" but shall not be less than 8 1/2".

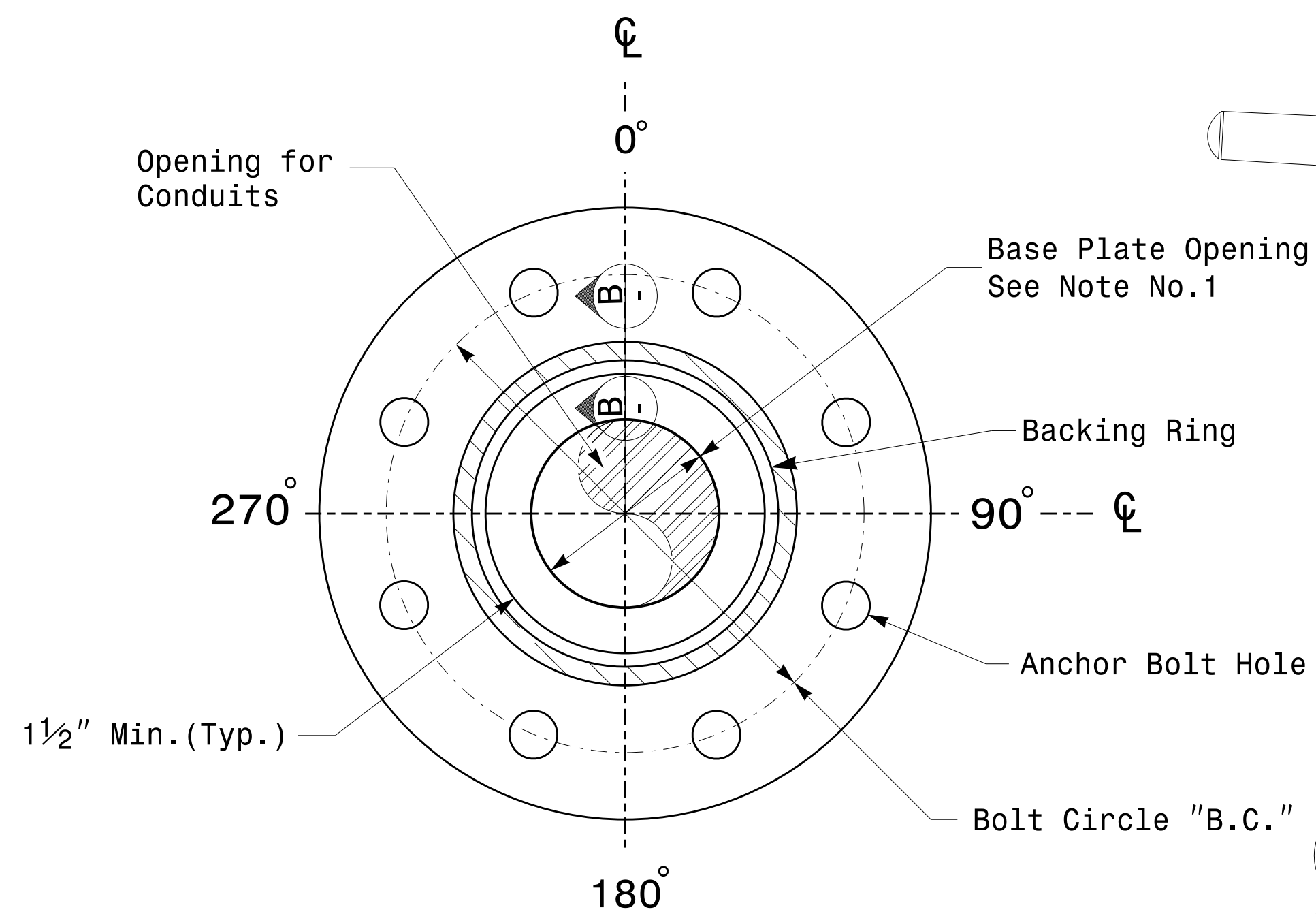

Section A-A
Pole Base Plate Details

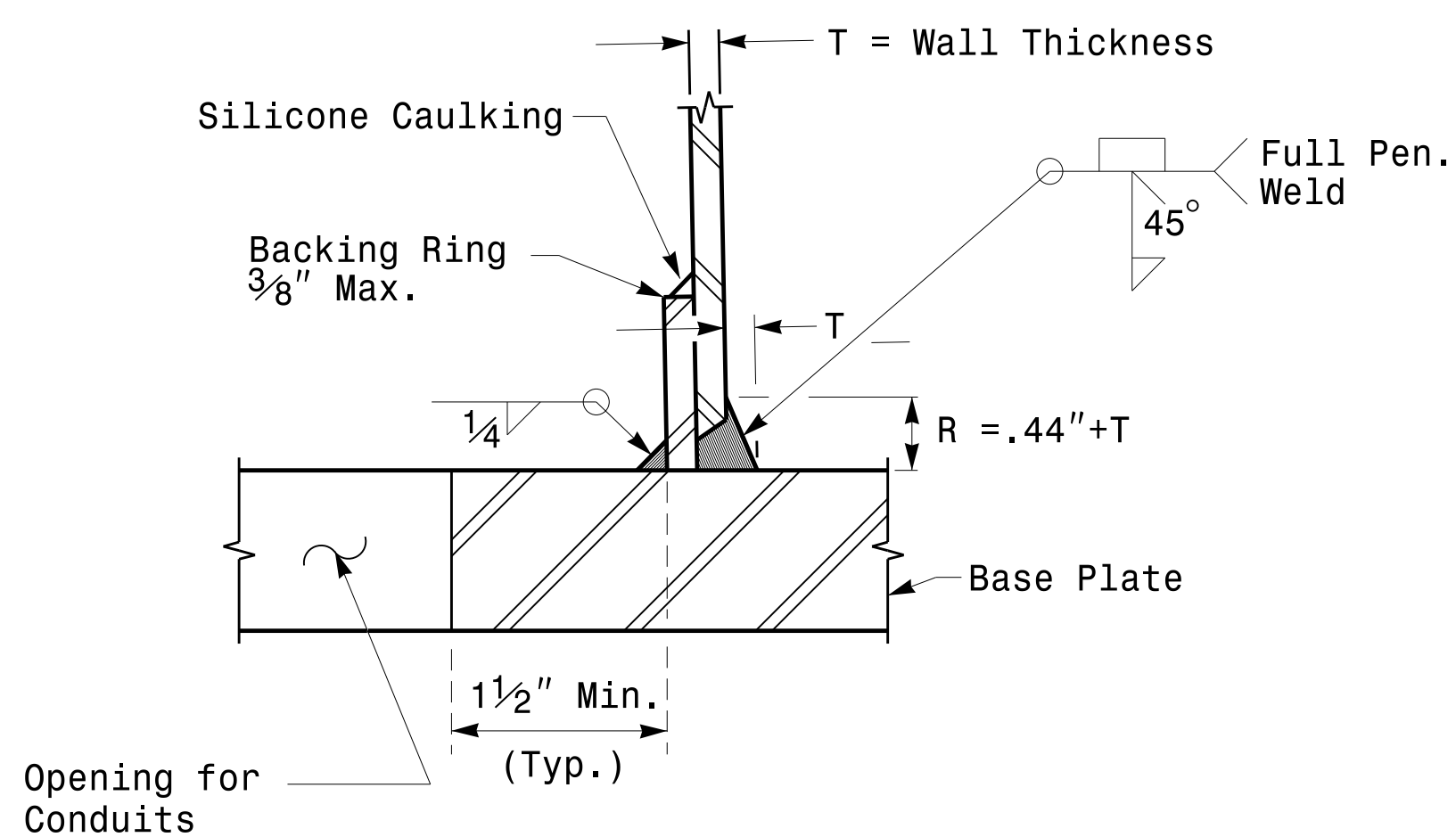

Section B-B
 (Pole Attachment to Base Plate)
Full-Penetration Groove Weld Detail

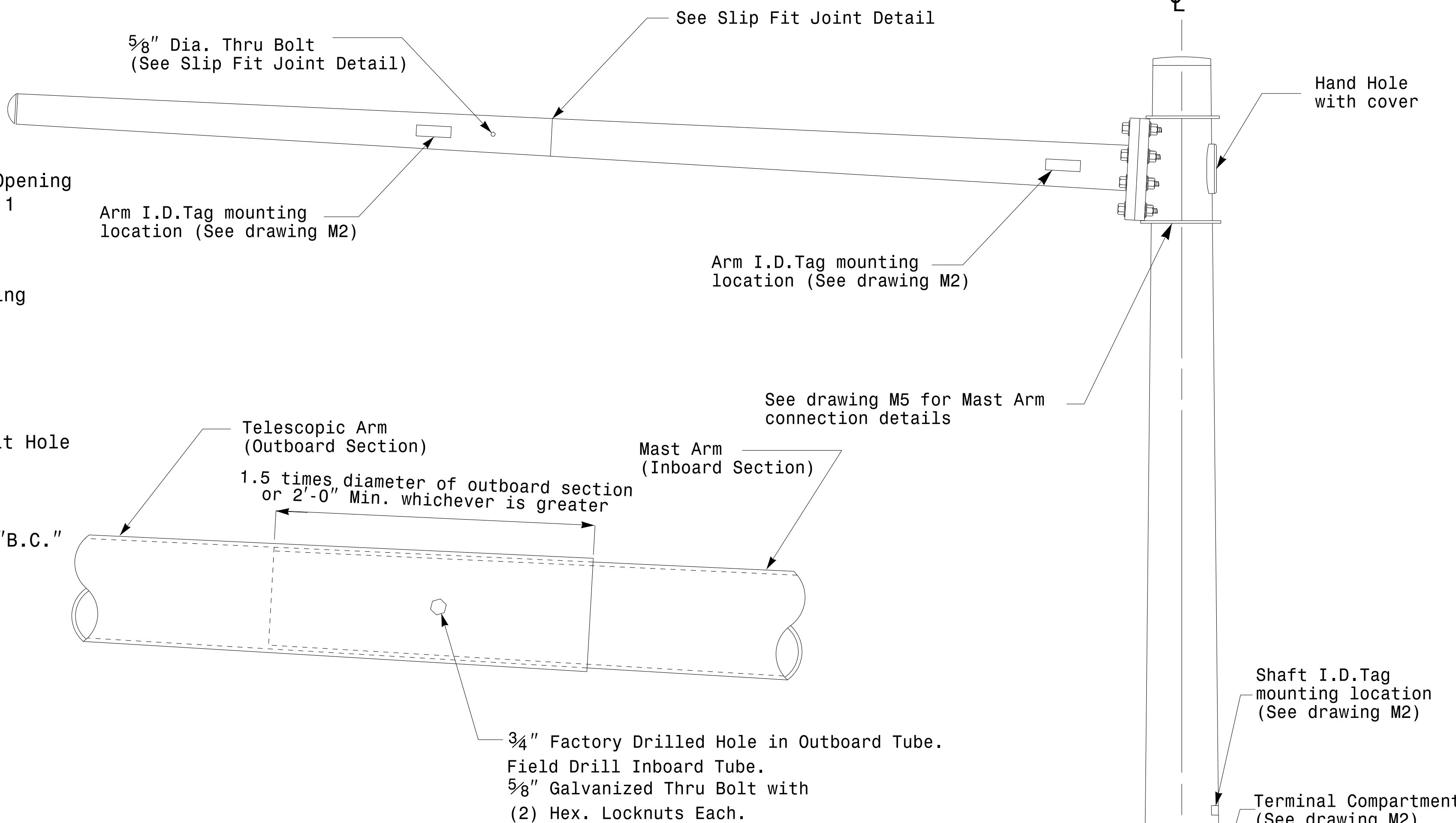

Slip Fit Joint Detail for Mast Arm

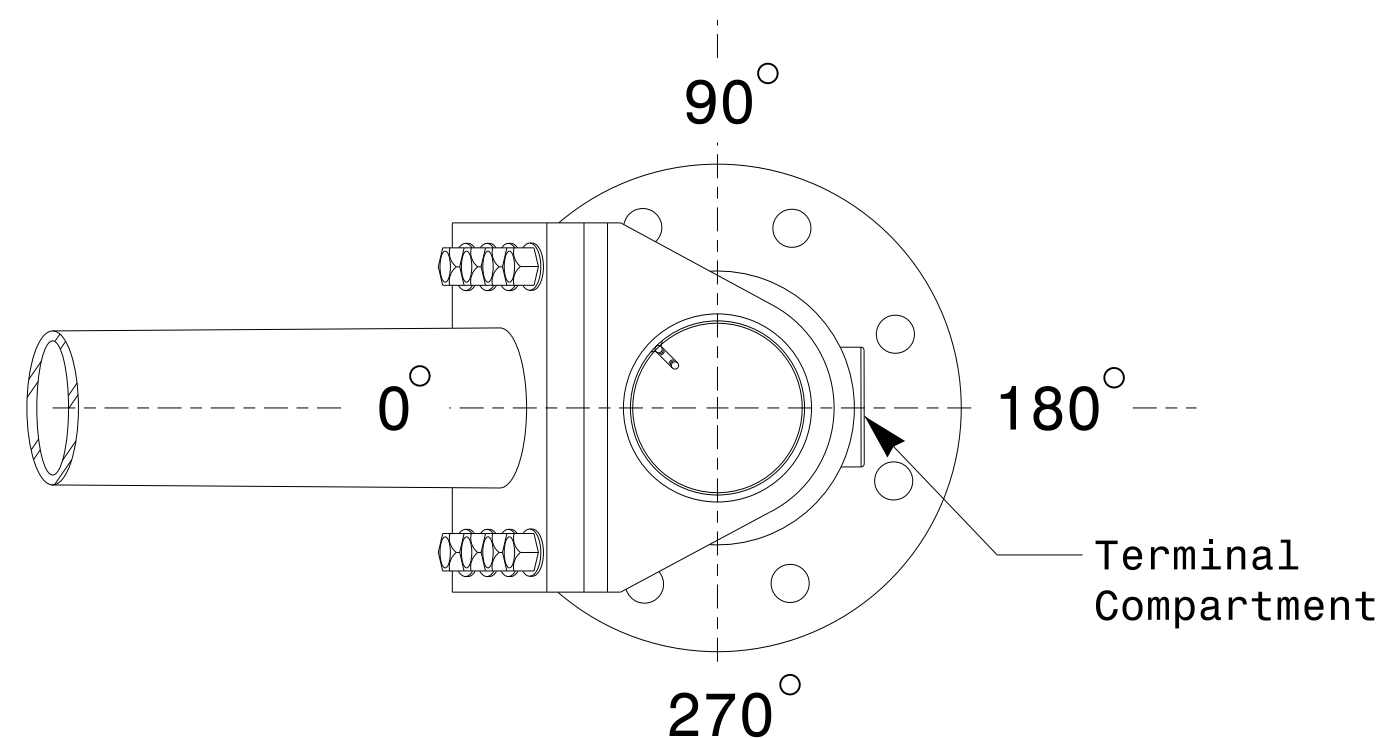

Mast Arm Radial Orientation

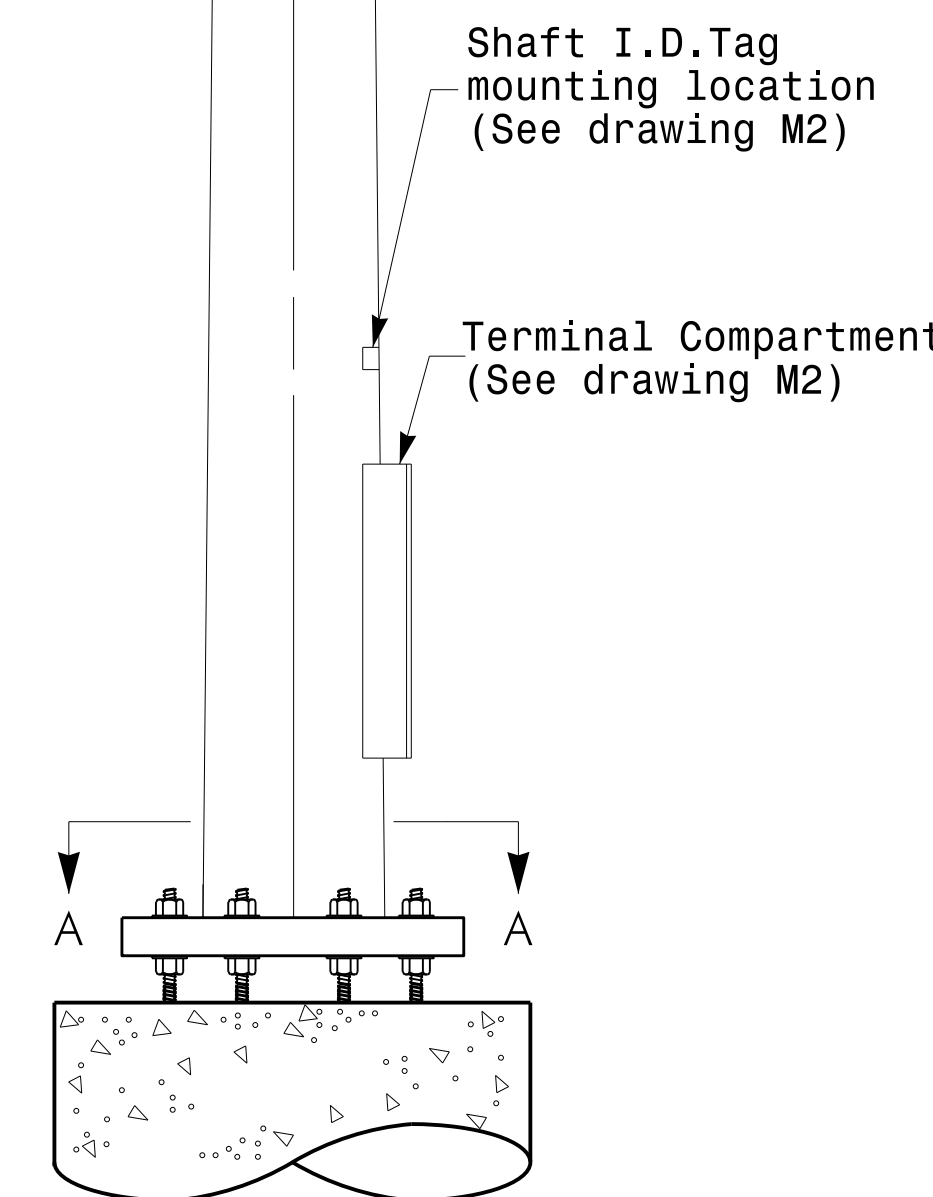

Mast Arm Pole

Fabrication Details – Mast Arm Poles

<p>Prepared in the Offices of: Transportation Mobility and Safety Division UNIVERSITY OF NORTH CAROLINA AT CHARLOTTE Signal Design Section 750 N. Greenfield Pkwy, Garner, NC 27529</p>	Typical Fabrication Details For Mast Arm Poles		SEAL D. C. SARKAR ENGINEER
	PLAN DATE: OCTOBER 2017 DESIGNED BY: K.C. DURIGON PREPARED BY: N. BITTING REVIEWED BY: D.C. SARKAR	REVISIONS INIT. DATE	
SCALE: 0 NA NONE	DocuSigned by: Dinesh C. Sarkar 10/11/2017		DATE

11-OCT-2017 08:33 136560115 Signal Design Section Eastern Region\m4 Sheets\2016\2014 Sig.M4 Std. Fabrication Detail\Mast Arm Poles.dgn