



**Safety Effectiveness of Flashing Yellow Arrow:
Evaluation of 222 Signalized Intersections in North Carolina**

January 13, 2015
TRB 94th Annual Meeting

Presentation Overview

- Background
- Literature Review
- Project Scope
- Methodology
- Site Selection
- Results by Category
- Conclusions



Background

2009 MUTCD

- FYA formally approved as recommended treatment for protective/permmissive left turn (PPLT) displays
- NCDOT approved FYA as preferred installation for new PPLT installations

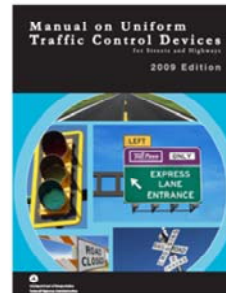

3

In the 2009 MUTCD, FYA was formally approved as the recommended configuration for protected/permmissive and permmissive left turn displays. Per Section 4D.13, circular green indications for permmissive left turns should not be located over or in front of an exclusive left turn lane for new or reconstructed signal installations. NCDOT has approved FYA as the preferred installation for new protected/permmissive left turn installations.

MUTCD Guidance:

Section 4D.13

09 For new or reconstructed signal installations, on an approach with an exclusive left turn lane(s) for a left-turn (or U-turn to the left) movement and with opposing vehicular traffic, signal faces that display a CIRCULAR GREEN signal indication should not be post-mounted on the far-side median or mounted overhead above the exclusive turn lane(s) or the extension of the lane(s).

Background

Two Types of FYA in North Carolina:

FYA-PPLT - 4 section

- Protected/Permissive Left Turn Mode
- Most Prevalent

Figure 4D-12. Typical Position and Arrangements of Separate Signal Faces with Flashing Yellow Arrow for Protected/Permissive Mode and Protected Only Mode Left Turns

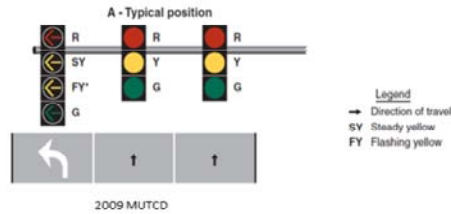

4

Two types of FYA are used in North Carolina, and are installed only when there is an exclusive lane for the left turn movement.

The type more prevalently used in North Carolina is FYA for protected/permissive left turn mode (FYA-PPLT). It has four sections: a steady red arrow, a steady yellow arrow, a flashing yellow arrow, and a steady green arrow.

Photo: Timber Drive and Grovemont Road in Garner, North Carolina

Background

Two Types of FYA in North Carolina:

FYA-Permissive Only - 3 section

- Not Bimodal Use* (No Green Arrow)
- Found at ~1/4 of intersections with FYA

Figure 4D-7. Typical Position and Arrangements of Separate Signal Faces with Flashing Yellow Arrow for Permissive Only Mode Left Turns

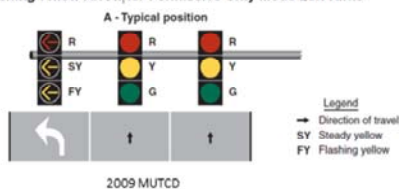

5

The other type used in North Carolina is FYA for permissive only left turns (FYA-Permissive Only). It has three sections: a steady red arrow, a steady yellow arrow, and a flashing yellow arrow. The FYA-Permissive Only sites used in this study are not for bimodal use. They are used on approaches with no exclusive left turn phase. The FYA-Permissive Only has been used in some cases where there are offset left turn lanes, railroad preemption is needed, consistency is necessary along a corridors, and as other circumstances arise.

Photo: Timber Drive and Grovemont Road in Garner, North Carolina

* Bimodal section (green arrow and yellow flashing arrow) may be used where it's impractical to use the four-section head. Some bimodal sites are planned in NC in near term.

Literature Review

- NCHRP Web-Only Document 123 (2007)
 - Over 50 Sites across the US, including North Carolina
 - No CMFs
- NCDOT Unpublished Study (2011)
 - Preliminary data – 55 sites

		Total	Target
Permissive Only to FYA Protected-Permissive		-15%	-68%
Protected Only to FYA Protected-Permissive		+27%	+467%
5 Section "Doghouse" Protected-Permissive to FYA Protected-Permissive		0%	-37%

6

Reports have studied the operational impacts and other effects of FYA-PPLT but few studies have provided a before and after crash analysis on more than a handful of sites. None of the published studies provide an overall target CMF for left turn crashes specific to the treated approaches, and none have provided a total or target CMF for the three-section FYA-Permissive Only. The following summary of literature to-date is specific to crash analysis studies on FYA.

NCHRP Web-Only Document 123 published in 2007 documents the follow-up safety study undertaken as recommended in *NCHRP Report 493*. Crash data was obtained from over 50 intersections where FYA-PPLT was implemented in California, Colorado, Florida, Michigan, North Carolina, Oregon, Virginia, Washington, and Wyoming. All sites had at least 1 year of after crash data. The data was broken up into three categories based on conditions at the intersection before the FYA installation: protected/permissive left turn, protected-only left turn, and permissive-only left turn.

The report provided the following general conclusions:

- “Safety was improved at intersections that operated with protected/permissive left-turn phasing prior to and after the field implementation of the FYA permissive indication.
- Safety was not improved at intersections that operated with protected only left-turn phasing prior to field implementation of the FYA indication with PPLT phasing.
- No conclusions can be made at intersections that operated with permissive only left turn phasing prior to implementation of the FYA indication, due to a minimal

number of implementation sites and data.”

Although the crash frequency increased at a majority of intersections converted from protected-only control, the authors noted that with time the crash rates did go down. As the number of months in the after period increased, the crash frequency decreased for this group of sites. While the study provided new insight into the effectiveness of FYA, the authors note the study’s shortcomings at the end of the report. This was the first safety evaluation of FYA and at the time there was limited after period data available. They felt future safety evaluations would be able to provide stronger statistical results by including a larger number of ‘after’ years in the data set. They also note the evaluation of known changes other than the FYA implementation at study sites was not included in this report. As such, CMF results were not provided.

In July 2011, NCDOT presented preliminary crash analysis results for FYA-PPLT. The presenter noted little ‘after’ data was available at the time and there were some smaller sample sizes because the data was categorized into smaller datasets. Because other changes were made to some signals at the time of the FYA installation, it was also noted that the effect of the FYA installation was difficult to single out. The results were categorized into three groups based on conditions at the site before the FYA-PPLT: Category 1 was permissive-only (6 sites), Category 2 was protected-only (10 sites), and Category 3 was 5-head “doghouse” PPLT (39 sites). Both total and target crashes were analyzed. Target crashes included left-turn same roadway (LTSR) crashes with a left turner on an approach with FYA. Only crashes where the officer coded the crash type to LTSR were reviewed to include in the target group. There are issues with this methodology, which will be discussed later.

The naïve before and after study of crash data resulted in the following crash reduction factors:

- Category 1
Total: 15% Reduction, Target: 68% Reduction
- Category 2
Total: 27% Increase, Target: 467% Increase
- Category 3
Total: 0%, Target: 37% Decrease

Based on these preliminary results, there was not enough data to make conclusive safety statements. However, the presenter reasoned the reduction in crashes for Category 1 is likely a factor of phase-change. Likewise, the large increase in crashes at Category 2 sites was likely due to the phasing change and not the FYA itself. The preliminary results for Category 3 seem promising for target crashes, but the presenter did not expect to see large reductions in total crashes with the final study.

Noyce, D. A., Brergh, C. R., & Chapman, J. R. (2007). *NCHRP web-only document 123: Evaluation of the Flashing Yellow Arrow Permissive-Only Left-Turn Indication Field Implementation*. Washington, D.C.: TRB, National Research Council.

Literature Review

- Charlotte, NC Safety Evaluation (2011)
 - Crash Analysis at 6 Intersections – No CMFs
- Safety Evaluation of FYA in Three Cities in WA and TX (2012)
 - Crash Rates at 51 intersections – No CMFs
- Crash Modification Factors for Changes to Left-Turn Phasing (2012)
 - Crash Analysis from NC, OR, WA - CMF Clearinghouse #s
 - All Left Turns included in “Target CMF”
 - No CMF for site with Permissive Only in Before Period
 - No CMF for sites with FYA-Permissive Only

7

A 2011 study by Pulugurtha et al evaluated the installations of FYA-PPLT at six signalized intersections in Charlotte, NC. The before period conditions on the approaches treated with FYA is not known. Empirical Bayes methodology was used. The results showed improvements in safety at five of the six study sites. The study showed that the number of total crashes at the treated sites would have generally increased had the FYA not been installed. The authors state that results considering larger sample sizes and considering only left-turn crashes need to be considered in future evaluations.

A 2012 study by Yi et al studied crash data at intersections where FYA -PPLT were installed. The study included 12 intersections from Texas which all operated with PPLT phasing in the before period and 39 intersections from two cities in Washington State where the before left-turn control types included protected-only, permissive-only, and PPLT. The results indicated that the overall average left-turn crash rate decreased by 2 percent for the study sites in all three cities involved in the study. The use of the FYA signal indication generally had no an adverse effect on the overall safety of the study intersections. The study solely compared intersection crash rates, and CMFs are not provided.

The most comprehensive before and after safety study on FYA-PPLT to date was published in 2012. “Crash Modification Factors for Changes to Left-Turn Phasing” provides CMFs for the implementation of FYA-PPLT based on data from 51 urban signalized intersections in Oregon, Washington State, and North Carolina. The North Carolina dataset contains sites included in the preliminary NCDOT evaluation. The empirical Bayes method was applied to the North Carolina sites but could not be applied to sites in the other States, although the

statistical methodology used combines some aspects of the empirical Bayes and the comparison group approaches. The authors note that a small portion (four of the five Washington sites) underwent known changes other than the installation of FYAs, and for these sites “the changes in the expected crashes cannot be totally attributed to the FYA installations”. Crash data by treated approaches were not provided in North Carolina, so the analysis of these sites focused on intersection-level crashes. The results for all three States were combined at the intersection-level and reported for total crashes and total left-turn crashes. The results are provided based on the before condition at the treated sites, and are provided for three types of change. The six CMF values listed here are listed in the CMF Clearinghouse for total and left turn crash types.

- Intersections at which the converted legs had protected-only phasing in the before period (29 Sites, 56 Legs Treated)
Total CMF: 1.338, Left Turn CMF: 2.242
- Intersections at which the converted legs had either permissive or protected–permissive phasing in the before period, and at least one of the converted legs had permissive phasing (9 Sites, 20 Legs Treated)
Total CMF: 0.753, Left Turn CMF: 0.635
- Intersections at which all of the converted legs had protected–permissive phasing in the before period (13 Sites, 27 Legs Treated)
Total CMF: 0.922, Left Turn CMF: 0.806

The results indicate a safety benefit at locations with some kind of permissive left-turn operation before and a disbenefit at locations that had a protected-only operation before. A CMF is not provided specifically for approaches with permissive only left-turn operation in the before period. The study offers statistically rigorous CMF results for FYA-PPLT under these three conditions, but there are additional safety related questions we want to address and additional CMF values we want to determine for this treatment.

Pulugurtha, S., Agurla, M., and Khader, K. How Effective are "Flashing Yellow Arrow" Signals in Enhancing Safety". Transportation and Development Institute Congress 2011: pp. 1096-1104. (2011)

Yi, et al, Use of Flashing Yellow Operations to Improve Safety at Signals with Protected-Permissive Left Turn (PPLT) Operations, Texas Southern University, Houston, Texas (2012)

Crash Modification Factors for Changing Left-Turn Phasing. R. Srinivasan, C. Lyon, B. Persaud, J. Baek, F. Gross, S. Smith, C. Sundstrom. *Transportation Research Record*, 2279, 108-117

Project Scope

Categories of FYA – Based on Before Phasing

- Category 1 – Permissive Only to FYA-PPLT
- Category 2 – Protected Only to FYA-PPLT
- Category 2A - Protected Only to FYA-PPLT with TOD Operation
- Category 3 – 5-Section PPLT to FYA-PPLT
- Category 4 – Permissive Only to FYA-Permissive Only

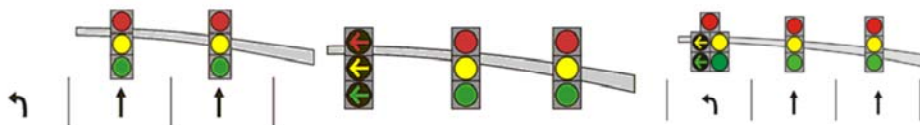

Image Source: Signalized Intersections: An Informational Guide

8

The purpose of this project is to determine whether the installation of FYA-PPLT, FYA-PPLT with TOD operation, or FYA-Permissive Only at signalized intersections reduces (or increases) the number and severity of total crashes and left turn crashes on approaches receiving the treatment. The study compares the crash data of signalized intersections before and after the FYA treatment is installed. The data is specific to North Carolina conditions and decision making, although other places with similar conditions may benefit from the findings as well. Based on prior studies we recognize the immense impact of the before period left turn phasing conditions on the treatment effectiveness and have categorized the data to reflect this.

The evaluation goals include the development of CMFs for FYA based on the specific before and after period conditions as categorized below:

Category 1 – Permissive Only to FYA-PPLT

Category 2 – Protected Only to FYA-PPLT

Category 2A – Protected Only to FYA-PPLT with TOD Operation

Category 3 – 5-Section “Doghouse” PPLT to FYA-PPLT

Category 4 – Permissive Only to FYA-Permissive Only

Images Source:

Signalized Intersections: An Informational Guide

Project Scope

Measures of Effectiveness

1. Total crashes
2. Target crashes, specifically defined as left-turn same roadway crashes with the left-turner on an approach treated with FYA and occurring during the time of day when FYA is in operation
3. Injury crashes for the total and target groups

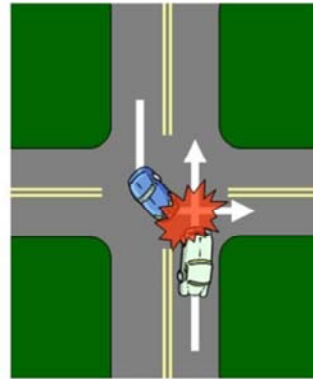

Image Source: Safety at Unsignalized Intersections

The measures of effectiveness for this project include:

1. Total crashes
2. Target crashes, specifically defined as left-turn same roadway crashes with the left-turner on an approach treated with FYA and occurring during the time of day when FYA is in operation
3. Injury crashes for the total and target groups

Image Source: Safety at Unsignalized Intersections

http://safety.fhwa.dot.gov/intersection/unsigalized/presentations/unsig_pps_041409/long.cfm

Methodology

- Before and After Crash Analysis with consideration for traffic increase
- Data comprised 3 years before & minimum 2 years after
- Installation Dates varied from 2006-2011, but many in 2010
- Target Crashes – required careful review

10

A before and after crash analysis with consideration for traffic increase was used to calculate the CMFs. Highway Safety Manual (HSM) safety performance functions (SPFs) for urban and suburban intersections were used to determine the effect of traffic volume trends on predicted crash frequency. SPFs provide an exponential form for relating volumes with expected crashes. The SPFs were used to create adjustment factors that incorporate the separate effects for Annual Average Daily Traffic (AADT) on the major and minor road legs in the before and after periods at each site. The before crash frequencies were multiplied by the ratio of after SPF predictions to before SPF predictions to obtain the expected number of after crashes.

The analysis does not account for selection bias or non-volume time trends, and does not address the threat of regression to the mean. Regression to the mean is the presumption that a site will return to its long-term mean crash frequency after an extraordinarily high or low period. Empirical Bayes before-and-after analysis, one of the techniques used to account for these potential deficiencies, was considered but not used for our study based on the following:

- Most sites were selected for treatment based on operational concerns or other non-safety issues. The average number of target crashes per year per intersection in the before period is small, only 1.08 crashes, which based on experience with urban signals in North Carolina suggests crash history was not a factor in treatment selection at many sites. Also, approximately 20 percent of signalized intersections in North Carolina currently use FYA or are planned for FYA in the near future. Therefore, we feel the bias

- due to regression to the mean was not evident in the selection of the treated locations.
- The Empirical Bayes approach requires the use of a reference group of sites similar to the treated ones but not receiving the treatment to account for changes in crashes unrelated to the treatment. Due to the large size of the treatment group, we decided the compilation and analysis of an adequate reference group of similar intersections located within the vicinity of the treatment sites (but not affected by the treatment or undergoing changes in the study periods) was not feasible for our study. Also, it would be a feat to obtain target crashes from any potential reference group because it entails the manual review of crash reports to identify the “true” left turn targets (our efforts to assemble target crashes are explained later in this section).

The crash analysis was performed for each intersection using the North Carolina Traffic Records Database, which at the time of the study contained all reported crashes in the State from 1990 through November 30, 2013. The FYA installation dates varied from 2006 through 2011, so the period analyzed for each location varied according to when the treatment was installed. The before period consisted of three years of data, and the after period varied from two to three years at each site. The crash analyses were terminated before other known countermeasures were implemented. The data consisted of all crashes within 150 feet of the treated intersections. Injury crashes included fatal and nonfatal injury crashes combined. The current reporting threshold for crashes in North Carolina is \$1,000.

Determination of target crashes required careful review of the crash data. We selected and reviewed every crash coded to four crash types: left turn same roadway (LTSR), left turn different roadway (LTDR), angle, and head on. Our target crash type is LTSR but it was necessary to include the additional crash types in our review because 45 percent of target crashes were comprised of crashes coded as LTDR, angle and head on when testing a subset of the sites. Had only the crashes coded as LTSR been selected to determine the target group, the results may have been very misleading. The selected crashes were reviewed to determine if they involved a left turning vehicle, if the vehicle was on an approach receiving the FYA, and if so, the category type on that approach. Also, if TOD operation was present, the day of the week and time of the crash were reviewed to determine if the crash occurred at a time when FYA was in operation.

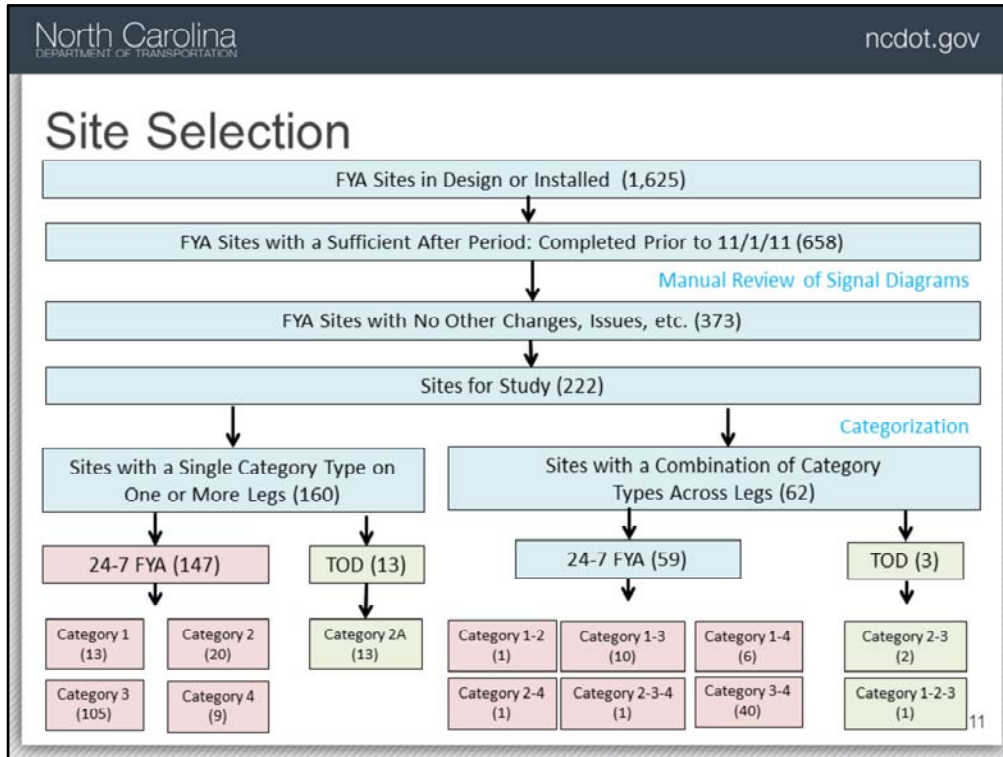

As of late 2013, 1,625 FYA installations were in design, transmitted, or installed through the State. The table shows the process we used for selecting our study sites. The number of sites in each group are listed in parenthesis. We only used sites completed prior to November 2011, which provided us with a minimum two years of ‘after’ data at each site. All sites had 3 years of ‘before’ data. Sites where the FYA was installed at a new signal are excluded from the study. Over 600 sites were manually reviewed for inclusion in the study. All signal files that were dated within a site’s study time periods were scanned to determine the category type and if major changes were made besides the FYA installation.

Sites were excluded or time periods cut if changes were noted from the signal plans that may possibly affect the results. We recognize that all changes (such as certain timing changes and other system tweaks) will not be accounted for at every site. Some of the reasons for excluding treatment sites included any of these changes that occurred during the study period:

- Intersection geometry changes or roadway widening
- Offsetting left turn lanes
- Phasing changes (unrelated to the FYA)
- Speed limit changes
- Other countermeasures implemented
- No signal plans found

222 sites with no other documented changes and with readily accessible crash data were

included in the study. Due to the number of FYA sites in our State with multiple years worth of available data, we were able to analyze much more data than prior research has been capable of.

Sites were grouped based on whether or not a TOD plan was in operation. If alternate phasing plans were listed on a signal plan, the local traffic engineer was contacted to determine if TOD operation is utilized and to obtain the time periods of operation. Most sites with TOD operation employ FYA during off peak hours (generally 9 pm – 6 am) and operate fully protected the remainder of the day. Very few sites in the study utilize TOD operation, although this option is beginning to be used more frequently. The only category with sites using TOD operation was Category 2, and there was a sufficient sample to create Category 2A for this sub-group. The remainder of sites in the study use FYA 24-7.

Sites were further categorized based on the before and after period conditions of each approach. Intersections with only a single category type on one or more legs were separated from intersections where combinations of category types were employed across the legs.

19 sites (less than 10% of the sample) were operated and maintained by the City of Charlotte Department of Transportation (CDOT). Most of the CDOT intersections fall within the Category 2A group with TOD FYA operation.

Site Selection

Example site A has a single category type on one or more legs. This site is exclusive to **Category 1** (leg 1 is Category 1 FYA, leg 2 is Category 1 FYA, and legs 3 and 4 remain unchanged).

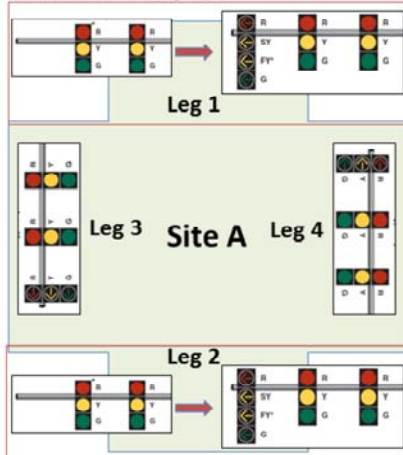

Example site B has a combination of category types across legs. This is a **Category 1-3** site (leg 1 is Category 1 FYA, leg 2 is a Category 3 FYA, and legs 3 and 4 remain unchanged).

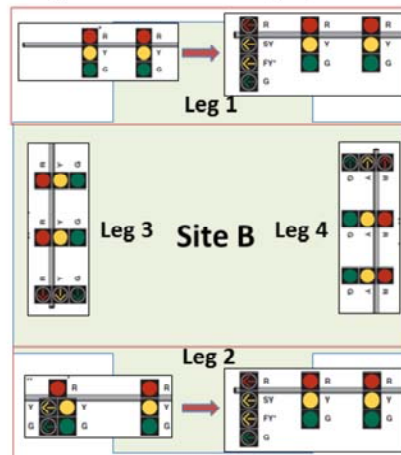

12

In the example above, both site A and site B are used to calculate Category 1 CMFs. Site A data is used on the intersection-level and the approach-level: intersection-level crashes are used to calculate a total CMF and an injury CMF for Category 1, while left turn crashes from leg 1 and leg 2 are used to calculate a target CMF and a target injury CMF for Category 1. Site B data is used on the approach-level only: left turn crashes from leg 1 are used to calculate a target CMF and a target injury CMF for Category 1.

This additional data proved helpful in backing up target CMF results in cases where limited sites were available.

Category 1: Permissive Only to FYA-PPLT Results

Average Target Crashes/Year/Site After: 0.6

Evaluation Results for Category 1 (Permissive Only to FYA-PPLT)

Source	Crash Type	π	λ	CMF	CRF
13 Sites (20 Treated Legs)					
	Total	171.3 ± 12.7	161 ± 12.7	0.935 ± 0.100	6.5% ± 10.0%
	Total Injury	61.7 ± 7.6	41 ± 6.4	0.654 ± 0.128	34.6% ± 12.8%
	Target	30.2 ± 5.3	23 ± 4.8	0.738 ± 0.195	26.2% ± 19.5%
	Target Injury	16.7 ± 3.9	12 ± 3.5	0.683 ± 0.240	31.7% ± 24.0%
30 Sites (41 Treated Legs)					
	Target	84.2 ± 9.2	51 ± 7.1	0.598 ± 0.105	40.2% ± 10.5%
	Target Injury	41.2 ± 6.3	25 ± 5.0	0.592 ± 0.146	40.8% ± 14.6%

Note: CMFs in bold are statistically different from 1.0 at the 5% level.



13

This table presents the results of the crash analysis for Category 1.

The value after the plus-or-minus sign indicates the estimate of standard deviation of an estimated parameter. Although the table provides both CMF and CRF estimates, the discussion of the results is limited to the CRF estimates for ease of discussion. A positive CRF estimate indicates a reduction in crashes.

For the 13 intersections (20 treated legs) exclusively receiving a Category 1 FYA, the results of the crash analysis yield a 7 percent reduction in total crashes, a 35 percent reduction in total injury crashes, and a 26 percent reduction in target crashes. For the 41 treated legs receiving a Category 1 FYA, the results yield a 40 percent reduction in target crashes.

Category 2: Protected Only to FYA-PPLT Results

Average Target Crashes/Year/Site After: 1.6

Evaluation Results for Category 2 (Protected Only to FYA-PPLT)

Source	Crash Type	π	λ	CMF	CRF
20 Sites (43 Treated Legs)					
	Total	390.4 ± 19.5	440 ± 21.0	1.124 ± 0.077	-12.4% ± 7.7%
	Total Injury	139.9 ± 11.7	170 ± 13.0	1.206 ± 0.136	-20.6% ± 13.6%
	Target	26.1 ± 5.0	93 ± 9.6	3.440 ± 0.727	-244.0% ± 72.7%
	Target Injury	11.8 ± 3.4	55 ± 7.4	4.308 ± 1.270	-330.8% ± 127.0%
23 Sites (49 Treated Legs)					
	Target	28.1 ± 5.2	107 ± 10.3	3.684 ± 0.748	-268.4% ± 74.8%
	Target Injury	11.8 ± 3.4	61 ± 7.8	4.778 ± 1.397	-377.8% ± 139.7%

Note: CMFs in bold are statistically different from 1.0 at the 5% level.



14

This table presents the results of the crash analysis for Category 2.

For the 20 intersections (43 treated legs) exclusively receiving a Category 2 FYA, the results of the crash analysis yield a 12 percent increase in total crashes, a 21 percent increase in total injury crashes, and a 244 percent increase in target crashes. For the 49 treated legs receiving a Category 2 FYA, the results yield a 268 percent increase in target crashes.

Category 2A: Protected Only to FYA-PPLT with TOD Results

Average Target Crashes/Year/Site After: 0.5

Evaluation Results for Category 2A (Protected Only to FYA-PPLT with TOD Operation)

Source	Crash Type	π	λ	CMF	CRF
13 Sites (28 Treated Legs)					
	Total	692.0 ± 25.0	624 ± 25.0	0.901 ± 0.048	9.9% ± 4.8%
	Total Injury	218.4 ± 14.0	203 ± 14.2	0.926 ± 0.088	7.4% ± 8.8%
	Target	6.4 ± 2.4	20 ± 4.5	2.732 ± 1.053	-173.2% ± 105.3%
	Target Injury	4.6 ± 2.1	13 ± 3.6	2.371 ± 1.043	-137.1% ± 104.3%
16 Sites (34 Treated Legs)					
	Target	6.4 ± 2.4	20 ± 4.5	2.732 ± 1.053	-173.2% ± 105.3%
	Target Injury	4.6 ± 2.1	13 ± 3.6	2.371 ± 1.043	-137.1% ± 104.3%

Note: CMFs in bold are statistically different from 1.0 at the 5% level. CMFs in italic are statistically different from 1.0 at the 10% level

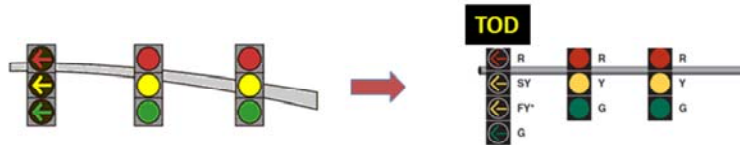

15

This table presents the results of the crash analysis for Category 2A.

For the 13 intersections (28 treated legs) exclusively receiving a Category 2A FYA, the results of the crash analysis yield a 10 percent reduction in total crashes, a 7 percent reduction in total injury crashes, and a 173 percent increase in target crashes. For the 34 treated legs exclusively receiving a Category 2A FYA, the results yield a 173 percent increase in target crashes.

Many sites with TOD operation used FYA only during night-time (commonly used hours from 9 pm – 6 am).

When TOD operation was present, the day of the week and time of the crash were reviewed. Only left turn crashes that occurred at a time of day when FYA was in operation were included as target crashes. As additional information, we analyzed the left turn crashes for all hours of the day to determine if there was any change when FYA was not in operation (when it was operating fully protected)....and we didn't find much change during the fully protected hours.

None of the results are statistically significant at the 95% confidence interval. However, the total and target crashes are statistically significant when tested at the 90 percent confidence interval which means a larger sample is required to detect the same level of effect with 95 percent certainty.

There may be real benefit in using TOD operation at locations where target crashes are occurring at specific times of day. These sites can be fully protected during the hours of peak crashes.

Category 3: 5-Section PPLT to FYA-PPLT Results

Average Target Crashes/Year/Site After: 1.0

Evaluation Results for Category 3 (5-Section PPLT to FYA-PPLT)

Source	Crash Type	π	λ	CMF	CRF
105 Sites (193 Treated Legs)					
	Total	1964.9 ± 43.6	1836 ± 42.8	0.934 ± 0.030	6.6% ± 3.0%
	Total Injury	683.4 ± 25.6	584 ± 24.2	0.853 ± 0.048	14.7% ± 4.8%
	Target	417.2 ± 20.1	325 ± 18.0	0.777 ± 0.057	22.3% ± 5.7%
	Target Injury	220.9 ± 14.6	150 ± 12.2	0.676 ± 0.071	32.4% ± 7.1%
156 Sites (254 Treated Legs)					
	Target	528.8 ± 22.6	444 ± 21.1	0.838 ± 0.053	16.2% ± 5.3%
	Target Injury	282.9 ± 16.5	212 ± 14.6	0.747 ± 0.067	25.3% ± 6.7%

Note: CMFs in bold are statistically different from 1.0 at the 5% level.



16

This table presents the results of the crash analysis for Category 3.

For the 105 intersections (193 treated legs) exclusively receiving a Category 3 FYA, the results of the crash analysis yield a 7 percent reduction in total crashes, a 15 percent reduction in total injury crashes, and a 22 percent reduction in target crashes. For the 254 treated legs receiving a Category 3 FYA, the results yield a 16 percent reduction in target crashes. All results are statistically significant at the 5% level.

Category 4: Permissive Only to FYA-Permissive Only Results

Average Target Crashes/Year/Site After: 0.1

Evaluation Results for Category 4 (Permissive Only to FYA-Permissive Only)

Source	Crash Type	π	λ	CMF	CRF
9 Sites (14 Treated Legs)					
	Total	140.1 ± 12.8	126 ± 11.2	0.892 ± 0.113	10.8% ± 11.3%
	Total Injury	59.7 ± 8.4	42 ± 6.5	0.689 ± 0.141	31.1% ± 14.1%
	Target	15.9 ± 4.3	7 ± 2.6	0.410 ± 0.177	59.0% ± 17.7%
	Target Injury	11.9 ± 3.7	4 ± 2.0	0.306 ± 0.164	69.4% ± 16.4%
57 Sites (64 Treated Legs)					
	Target	33.1 ± 5.8	17 ± 4.1	0.498 ± 0.145	50.2% ± 14.5%
	Target Injury	21.9 ± 4.8	8 ± 2.8	0.349 ± 0.139	65.1% ± 13.9%

Note: CMFs in bold are statistically different from 1.0 at the 5% level.



17

This table presents the results of the crash analysis for Category 4.

For the 9 intersections (14 treated legs) exclusively receiving a Category 4 FYA, the results of the crash analysis yield an 11 percent reduction in total crashes, a 31 percent reduction in total injury crashes, and a 59 percent reduction in target crashes. For the 64 treated legs receiving a Category 4 FYA, the results yield a 50 percent reduction in target crashes. All results except total crashes are statistically significant at the 5% level.

The Category 4 target crash results are larger than expected and may be related to an additional signal head being installed for the permissive left turn (occurred often at the Category 3-4 sites). When looking at changes in other crash types, rear end and angle crashes actually increased some.

Additional Analysis Target Crash Trends By Category

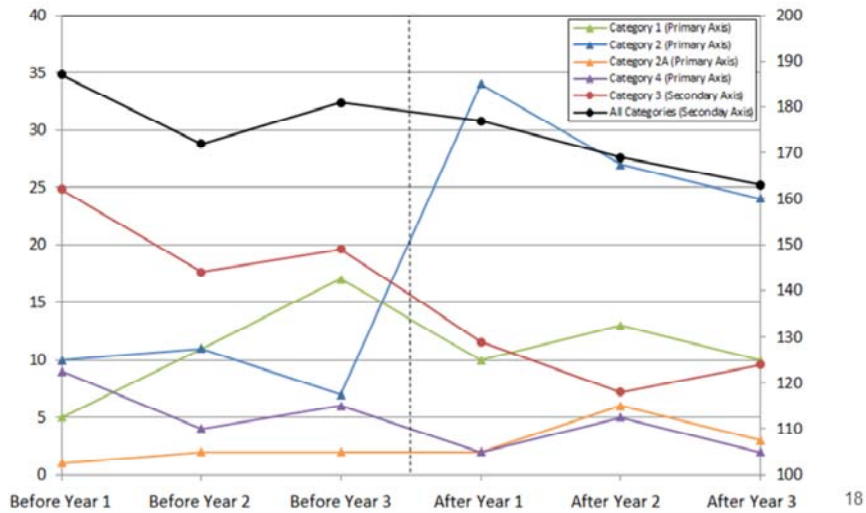

We investigated the number of target crashes per year for each category before and after the FYA installations. The graph shows the results of our analysis for the three years preceding and the three years following the treatment. The data from 154 treatment sites with a complete three year after period were analyzed. Note the Category 3 results and the aggregate results are plotted on a secondary y-axis because the values for this groups were much larger than the others.

The crash trends were analyzed to determine if there was a novelty effect associated with the treatment possibly resulting in a larger frequency of crashes in the first year after FYA was implemented. Considering all categories, the results show the highest frequency of after period target crashes in the first year after FYA installation with an overall decline in target crashes each remaining year. This trend may explain why the preliminary NCDOT results are higher than the results now reported with a more complete set of after data.

Category 2 (protected only to FYA-PPLT) demonstrates a jump in target crashes in the first year after installation that appears to decrease with time, but remains well above the before period trends. This reflects similar findings as Noyce who suggested that crashes increase at intersections converted from protected-only control although crash rates decrease with time. This effect is likely due to both the change in phasing as well as the change in the left turn signal display.

Additional Analysis

- What role do site characteristics play (Category 3)?

Mainline Characteristics	Sites	Average AADT	Target	Total
Low Speeds - 2-3 Lane	11	22,000	68.9 +/- 13.8	5.7 +/- 11.3
Low Speed - 4-5 Lane	15	25,000	50.7 +/- 12.4	5.5 +/- 7.8
High Speed - 2-3 Lane	18	17,200	27.1 +/- 19.8	13.7 +/- 8.8
High Speed - 4-5 Lane	56	27,700	16.3 +/- 7.1	6.6 +/- 3.9
All Speeds - 6-7 Lane	5	36,700	12.4 +/- 22.9	2.2 +/- 10.9

Mainline Characteristics	Sites	Average AADT	Target	Total
Low Speed - 2-3 Lane (< 25,000 AADT)	7	14,200	69.2 +/- 18.4	4.2 +/- 15.8
Low Speed - 2-3 Lane (> 25,000 AADT)	4	35,800	71.3 +/- 17.1	8.5 +/- 15.8
Low Speed - 4-5 Lane (< 25,000 AADT)	8	19,200	83.4 +/- 11.7	-4.4 +/- 13.6
Low Speed - 4-5 Lane (> 25,000 AADT)	7	31,700	40.9 +/- 16.0	11.7 +/- 9.4
High Speed - 2-3 Lane (< 25,000 AADT)	14	13,800	70.3 +/- 17.8	8.9 +/- 13.3
High Speed - 2-3 Lane (> 25,000 AADT)	4	29,300	10.9 +/- 27.3	18.3 +/- 11.5
High Speed - 4-5 Lane (< 25,000 AADT)	25	20,200	28.4 +/- 11.2	11.5 +/- 7.1
High Speed - 4-5 Lane (> 25,000 AADT)	31	33,800	11.1 +/- 9.0	4.9 +/- 4.6

19

Based on this table, it appears that the Higher Speed, Higher Volume, Larger Cross-Section, Generally Lesser Reduction in Target Crashes.
Also, Target injury CRFs follow the same trends as Target CRFs.

Conclusions

Category 3 & 4

- Category 3 - main objective of study
- Statistically significant decrease in target & injury crashes when going from a solid green ball to a FYA for permissive left turns when phasing remains unchanged
- Applies regardless of whether the left phasing is protected/permissive or fully permissive

Other Categories

- Results not surprising – changes in crashes are likely a factor of phase-change in addition to the FYA
- Results are not as robust, which suggests variability in performance and a need for more samples

Conclusions

TOD Operation

- May be real benefits in using TOD operation at locations where target crashes are occurring at specific times of day. Operate in fully protected mode only during hours of peak crash frequency.
- We plan to look more into this as more sites come online.

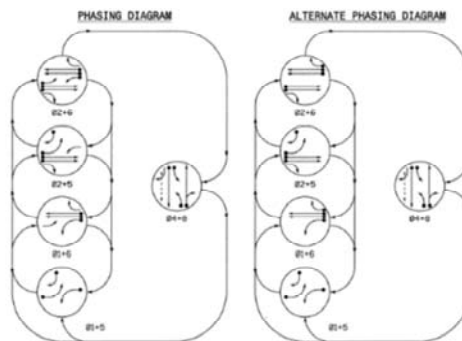

21

FUTURE RESEARCH WITH TOD OPERATION - We plan to look more into the safety effects of TOD operation as more sites come online. It appears that the safety of sites changed from fully protected to FYA-PPLT only during off-peak hours (Category 2A) may not be degraded as much as sites changed from fully protected to FYA-PPLT 24-7 (Category 2). Also, there may be real benefits in using TOD operation at locations where target crashes are occurring at specific times of day. The left turn signal may be operated in fully protected mode only during the hours identified as having peak crash frequency.

Questions?

Carrie L. Simpson, PE
clsimpson@ncdot.gov

Shawn A. Troy, PE
stroy@ncdot.gov

<https://connect.ncdot.gov/resources/safety/Pages/Safety-Evaluation.aspx>