

Signals and Intelligent Transportation Systems
Project Special Provisions
(Version 24.0)

Prepared By: _____
9-Aug-23

Document not considered final
unless all signatures completed.

Contents

1. 2024 STANDARD SPECIFICATIONS FOR ROADS & STRUCTURES.....8
1.1. RESERVED FOR FUTURE USE8
2. SIGNAL HEADS.....8
2.1. MATERIALS8
A. General:8
B. Vehicle Signal Heads:.....9
C. Pedestrian Signal Heads:13
D. Bus Rapid Transit Signal Heads:14
E. Optically-Programmed Vehicle Signal Sections:.....15
F. Louvers:15
3. LED BLANKOUT SIGN.....15
3.1. MATERIALS15
4. CONTROLLERS WITH CABINETS16
4.1. MATERIALS – TYPE 170E CONTROLLERS16
4.2. MATERIALS – TYPE 2070L CONTROLLERS17
4.3. MATERIALS – NEMA TS-1 CONTROLLERS18
4.4. MATERIALS – NEMA TS-2 TYPE 2 CONTROLLERS18
4.5. MATERIALS – TYPE 2070E CONTROLLERS18
4.6. MATERIALS – DEPARTMENT FURNISHED TYPE 2070 CONTROLLERS18
4.7. MATERIALS – TYPE 2070LX CONTROLLERS18
4.8. MATERIALS – GENERAL CABINETS19
4.9. MATERIALS – TYPE 170E CABINETS20
A. Type 170 E Cabinets General:20
B. Type 170 E Cabinet Electrical Requirements:20
C. Type 170 E Cabinet Physical Requirements:.....27
D. Model 2018 Enhanced Conflict Monitor:30
E. Preemption and Sign Control Box40
4.10. MATERIALS – ADVANCED TRANSPORTATION CONTROLLER CABINET (ATCC)43
A. ATC Cabinet Components:.....43
B. ATC Cabinet General Requirements45
C. Model 352i ATC Cabinet with 16-Channel Output and 24-Channel Input50
D. Model 352i ATC Cabinet with 16-Channel Output and 48-Channel Input51
E. Model 352i ATC Cabinet with 32-Channel Output and 48-Channel Input52
F. Model 356i ATC Cabinet54
G. Cabinet Assemblies55
4.11. MATERIALS – NEMA TS-1 CABINETS57
A. NEMA TS-1 Cabinet Physical Requirements:.....57
B. NEMA TS-1 Cabinet Electrical Requirements:59
C. NEMA TS-1 Conflict Monitors:63
4.12. MATERIALS – NEMA TS-2 TYPE 1 CABINETS64

- A. NEMA TS-2 Type 1 Cabinets General:..... 64
- B. NEMA TS-2 Type 1 Cabinet Physical Requirements: 64
- C. NEMA TS-2 Type 1 Cabinet Electrical Requirements:..... 65
- 4.13. MATERIALS – TYPE 170 DETECTOR SENSOR UNITS 71
- 4.14. MATERIALS – NEMA TS-1 DETECTORS 72
- 4.15. MATERIALS – NEMA TS-2 DETECTOR CARDS AND RACKS 72
- 4.16. MEASUREMENT AND PAYMENT 73
- 5. PUSH BUTTON INTEGRATED ACCESSIBLE PEDESTRIAN SIGNAL (APS) 73**
 - 5.1. DESCRIPTION 73
 - 5.2. MATERIALS 73
 - 5.3. CONSTRUCTION METHODS 74
 - 5.4. MEASUREMENT AND PAYMENT 75
- 6. VIDEO IMAGING LOOP EMULATOR DETECTOR SYSTEMS FOR TEMPORARY INSTALLATION
75**
 - 6.1. DESCRIPTION 75
 - 6.2. MATERIALS 75
 - A. General: 75
 - B. Loop Emulator System: 77
 - C. Video Imaging Loop Emulator System Support:..... 78
 - 6.3. CONSTRUCTION METHODS 78
 - 6.4. MEASUREMENT AND PAYMENT 79
- 7. VIDEO DETECTION SYSTEMS 80**
 - 7.1. DESCRIPTION 80
 - A. General..... 80
 - 7.2. MATERIALS 80
 - A. General..... 80
 - 7.3. CONSTRUCTION METHODS 86
 - A. Construction..... 86
 - B. Quality Acceptance/Testing..... 88
 - C. Contractor Warranty and Maintenance 89
 - D. Training 89
 - 7.4. MEASUREMENT AND PAYMENT 90
- 8. MICROWAVE VEHICLE DETECTOR – SINGLE ZONE 90**
 - 8.1. DESCRIPTION 90
 - 8.2. MATERIALS 90
 - 8.3. CONSTRUCTION METHODS 91
 - 8.4. MEASUREMENT AND PAYMENT 91
- 9. MICROWAVE VEHICLE DETECTION SYSTEM - MULTIPLE DETECTION ZONES 91**
 - 9.1. DESCRIPTION 91
 - 9.2. MATERIALS 91
 - 9.3. CONSTRUCTION METHODS 92
 - 9.4. MEASUREMENT AND PAYMENT 93
- 10. WIRELESS MAGNETIC SENSOR VEHICLE DETECTION SYSTEM 93**
 - 10.1. DESCRIPTION 93
 - 10.2. MATERIALS 93
 - 10.3. CONSTRUCTION METHODS 94
 - 10.4. MEASUREMENT AND PAYMENT 95
- 11. GPS UNIT - OASIS..... 95**
 - 11.1. DESCRIPTION 95
 - 11.2. MATERIALS 95
 - 11.3. CONSTRUCTION METHODS 95

11.4. MEASUREMENT AND PAYMENT95

12. GPS UNIT - GENERIC95

12.1. DESCRIPTION95

12.2. MATERIALS96

12.3. CONSTRUCTION METHODS96

12.4. MEASUREMENT AND PAYMENT96

13. TEMPORARY STATIONARY TRAFFIC SIGNAL SYSTEM.....96

13.1. DESCRIPTION96

13.2. MATERIALS96

13.3. CONSTRUCTION METHODS96

13.4. MEASUREMENT AND PAYMENT97

14. PORTABLE TRAFFIC SIGNAL SYSTEM97

14.1. DESCRIPTION97

14.2. MATERIALS97

14.3. CONSTRUCTION METHODS99

14.4. MEASUREMENT AND PAYMENT100

15. METAL POLE SUPPORTS101

15.1. METAL POLES101

A. General:101

B. Materials:103

C. Design:104

D. Strain Poles:106

E. Mast Arm Poles:107

F. CCTV and MVD Poles:108

G. Luminaire Arms:109

15.2. DRILLED PIER FOUNDATIONS FOR METAL POLES109

A. Description:110

B. Soil Test and Foundation Determination:110

C. Drilled Pier Construction:112

15.3. METAL POLE REMOVALS113

A. Description:113

B. Construction Methods:113

15.4. POLE NUMBERING SYSTEM113

A. New Poles113

B. Reused Poles113

15.5. REUSED POLE SHAFTS113

15.6. REUSED MAST ARM SHAFTS113

15.7. MEASUREMENT AND PAYMENT113

16. PROTECTIVE COATING FOR METAL POLES114

16.1. GENERAL114

16.2. DESCRIPTION115

16.3. MATERIALS115

16.4. FACILITY APPROVAL115

16.5. POWDER COATING116

A. Galvanizing116

B. Surface Preparation116

C. Powder Coating Application and Curing117

D. Quality Control117

E. Storage, Shipping, and Handling117

F. Repair of Powder Coated Material117

16.6. ACRYLIC PRIMER AND TOPCOAT PAINT SYSTEM118

A. Description118

B. Surface Preparation118

C. Materials 119

D. Painting 119

E. Curing 119

F. Inspection 119

G. Handling 120

H. Repair of Damaged Coating 120

16.7. MEASUREMENT AND PAYMENT 120

17. RECTANGULAR RAPID FLASHING BEACON SOLAR POWERED DISPLAY AND CONTROLLER ASSEMBLY 120

17.1. DESCRIPTION 120

17.2. MATERIALS 121

17.3. CONSTRUCTION METHODS 122

17.4. MEASUREMENT AND PAYMENT 122

18. ETHERNET EDGE SWITCH..... 122

18.1. DESCRIPTION 123

A. Ethernet Edge Switch: 123

B. Network Management: 123

18.2. MATERIALS 123

A. General: 123

B. Compatibility Acceptance..... 123

C. Standards: 123

D. Functional: 124

E. Physical Features: 124

F. Management Capabilities: 125

G. Electrical Specifications: 126

H. Environmental Specifications: 126

I. Ethernet Patch Cable: 127

18.3. CONSTRUCTION METHODS 127

A. General: 127

B. Edge Switch: 128

18.4. MEASUREMENT AND PAYMENT 128

19. COMMUNICATIONS SYSTEM SUPPORT EQUIPMENT 128

19.1. DESCRIPTION 128

19.2. MATERIALS 128

A. General: 128

B. Fiber-Optic Support Equipment..... 128

C. Wireless Radio Support Equipment..... 130

19.3. MEASUREMENT AND PAYMENT 130

20. FIBER-OPTIC TRAINING 131

20.1. DESCRIPTION 131

20.2. MATERIALS 131

20.3. MEASUREMENT AND PAYMENT 132

21. SOLAR POWER, 900 MHZ SPREAD SPECTRUM RADIO 133

21.1. DESCRIPTION 133

21.2. MATERIALS 133

A. 900MHz Wireless Radio System: 133

B. Solar Powered Assembly: 133

21.3. CONSTRUCTION METHODS 135

A. Antenna Mounting: 135

B. Solar Power Assembly: 136

21.4. MEASUREMENT AND PAYMENT 136

22. DIGITAL CCTV CAMERA ASSEMBLY 137

22.1. DESCRIPTION..... 137

22.2. MATERIALS 137

 A. General..... 137

 B. Camera and Lens 137

 C. Camera Housing 138

 D. Pan and Tilt Unit..... 139

 E. Video Ethernet Encoder..... 139

 F. Control Receiver/Driver 139

 G. Electrical 140

 H. CCTV Camera Attachment to Pole..... 140

 I. Riser..... 140

 J. Data line Surge Suppression 140

 K. POE Injector 141

22.3. CONSTRUCTION METHODS 141

 A. General..... 141

 B. Electrical and Mechanical Requirements..... 142

 C. General Test Procedure..... 142

 D. Compatibility Tests..... 142

 E. Operational Field Test (On-Site Commissioning) 143

 F. Local Field Testing 143

 G. Central Operations Testing 144

22.4. MEASUREMENT AND PAYMENT..... 144

23. CCTV FIELD EQUIPMENT CABINET..... 144

 23.1. DESCRIPTION..... 144

 23.2. MATERIALS 145

 A. CCTV Cabinet 145

 B. Shelf Drawer..... 145

 C. Cabinet Light 145

 D. Surge Protection for System Equipment..... 145

 23.3. CONSTRUCTION METHODS 148

 A. General..... 148

 23.4. MEASUREMENT AND PAYMENT..... 148

24. CCTV WOOD POLE 148

 24.1. DESCRIPTION..... 148

 24.2. MATERIALS 149

 24.3. CCTV WOOD POLE..... 149

 24.4. CONSTRUCTION METHODS 149

 24.5. MEASUREMENT AND PAYMENT..... 149

25. AIR TERMINAL & LIGHTNING PROTECTION SYSTEM..... 149

 25.1. DESCRIPTION..... 149

 25.2. MATERIALS 149

 A. General..... 149

 B. Wood Pole 150

 C. Metal Pole 150

 D. Copper Lightning Conductor and Ground Rods 150

 25.3. CONSTRUCTION METHODS 150

 A. Wood Pole 150

 B. Metal Pole..... 151

 C. Copper Lightning Conductor and Ground Rods 151

 25.4. MEASUREMENT AND PAYMENT..... 151

26. CCTV CAMERA LOWERING SYSTEM 151

 26.1. DESCRIPTION..... 151

 26.2. MATERIALS 152

- A. Winch Cable152
- B. Camera Connection Unit152
- C. Metal Frame and Winch Assembly.....153
- D. Variable Speed Drill154
- 26.3. CONSTRUCTION METHODS154
- 26.4. MEASUREMENT AND PAYMENT.....154
- 27. DYNAMIC MESSAGE SIGN (DMS)154**
- 27.1. DESCRIPTION154
- 27.2. MATERIALS156
- A. Environmental and Operating Requirements.....156
- B. Viewing Requirements for all DMS156
- C. Housing Requirements for all DMS156
- D. Housing Requirements for Walk-in type DMS.....156
- E. Housing Requirements for Front Access DMS.....157
- F. Housing Face Requirements for all DMS157
- G. Housing Face Requirements for Walk-in type DMS157
- H. Housing Face Requirements for Front Access type DMS158
- I. Housing Face Requirements for Embedded Front Access type DMS158
- J. Sign Housing Ventilation System for all DMS.....158
- K. Sign Housing Ventilation System for Walk-in DMS.....159
- L. Sign Housing Photoelectric sensors.....159
- M. Display Modules.....159
- N. Discrete LEDs.....159
- O. LED Power Supplies.....160
- P. LED Pixels.....161
- Q. DMS Mini Controller161
- R. DMS Enclosure Structure Mounting161
- S. DMS / DMS Controller Interconnect.....161
- T. DMS Controller and DMS Cabinet.....162
- U. Equipment List.....168
- V. Physical Description169
- W. Parts List.....169
- X. Character Set Submittal169
- Y. Wiring Diagrams169
- Z. Routine of Operation169
- AA. Maintenance Procedures169
- BB. Repair Procedures.....170
- CC. Warranty170
- 27.3. CONSTRUCTION METHODS170
- A. Description.....170
- B. Layout.....170
- C. Construction Submittal171
- D. Conduit171
- E. Wiring Methods (Power)171
- F. Equipment and Cabinet Mounting172
- G. Work Site Clean-Up172
- 27.4. GENERAL TEST PROCEDURE172
- 27.5. COMPATIBILITY TESTS173
- A. DMS System.....173
- 27.6. OPERATIONAL FIELD TEST (ON-SITE COMMISSIONING).....173
- A. DMS System.....173
- 27.7. MEASUREMENT AND PAYMENT174
- 28. NTCIP REQUIREMENTS175**
- 28.1. REFERENCES175
- A. Standards175

- B. Features.....176
- C. Objects.....176
- D. MULTI Tags.....179
- E. Documentation.....179
- F. NTCIP Acceptance Testing180
- 28.2. MEASUREMENT AND PAYMENT.....180
- 29. DMS PEDESTAL STRUCTURE180**
 - 29.1. DESCRIPTION180
 - 29.2. MATERIALS181
 - 29.3. CONSTRUCTION METHODS181
 - A. General.....181
 - B. DMS Maintenance Platform (Walkway)181
 - C. DMS Access Ladder.....182
 - 29.4. MEASUREMENT AND PAYMENT182
- 30. ELECTRICAL SERVICE FOR ITS DEVICES183**
 - 30.1. DESCRIPTION183
 - 30.2. MATERIAL183
 - A. Meter Base/Disconnect Combination Panel183
 - B. Equipment Cabinet Disconnect.....184
 - E. 3-Wire Copper Feeder Conductors185
 - F. 4-Wire Copper Feeder Conductors185
 - G. Grounding System185
 - 30.3. CONSTRUCTION METHODS186
 - 30.4. MEASUREMENT AND PAYMENT187
- 31. SOLAR POWER ASSEMBLY188**
 - 31.1. DESCRIPTION.....188
 - 31.2. MATERIAL.....188
 - 31.3. CONSTRUCTION METHODS189
 - 31.4. MEASUREMENT AND PAYMENT190
- 32. OBSERVATION PERIOD FOR ITS DEVICES190**
 - 32.1. 30-DAY OBSERVATION PERIOD.....190
 - 32.2. FINAL ACCEPTANCE.....191
 - 32.3. MEASUREMENT AND PAYMENT.....191

1. 2024 STANDARD SPECIFICATIONS FOR ROADS & STRUCTURES

The 2024 Standard Specifications are revised as follows:

1.1. RESERVED FOR FUTURE USE

Page xx-xxx, line xx, revise “insert changes here”.

2. SIGNAL HEADS

2.1. MATERIALS

A. General:

Fabricate vehicle signal head housings and end caps from die-cast aluminum. Fabricate 12-inch and 16-inch pedestrian signal head housings and end caps from die-cast aluminum. Fabricate 9-inch pedestrian signal head housings, end caps, and visors from virgin polycarbonate material. Provide visor mounting screws, door latches, and hinge pins fabricated from stainless steel. Provide interior screws, fasteners, and metal parts fabricated from stainless steel.

Fabricate tunnel and traditional visors from sheet aluminum.

Paint all surfaces inside and outside of signal housings and doors. Paint outside surfaces of tunnel and traditional visors, wire outlet bodies, wire entrance fitting brackets and end caps when supplied as components of messenger cable mounting assemblies, pole and pedestal mounting assemblies, and pedestrian pushbutton housings. Have electrostatically-applied, fused-polyester paint in highway yellow (Federal Standard 595C, Color Chip Number 13538) a minimum of 2.5 to 3.5 mils thick. Do not apply paint to the latching hardware, rigid vehicle signal head mounting brackets for mast-arm attachments, messenger cable hanger components or balance adjuster components.

Have the interior surfaces of tunnel and traditional visors painted an alkyd urea black synthetic baking enamel with a minimum gloss reflectance and meeting the requirements of MIL-E-10169, “Enamel Heat Resisting, Instrument Black.”

Where required, provide polycarbonate signal heads and visors that comply with the provisions pertaining to the aluminum signal heads listed on the QPL with the following exceptions:

Fabricate signal head housings, end caps, and visors from virgin polycarbonate material. Provide UV stabilized polycarbonate plastic with a minimum thickness of 0.1 ± 0.01 inches that is highway yellow (Federal Standard 595C, Color Chip 13538). Ensure the color is incorporated into the plastic material before molding the signal head housings and end caps. Ensure the plastic formulation provides the following physical properties in the assembly (tests may be performed on separately molded specimens):

Test	Required	Method
Specific Gravity	1.17 minimum	ASTM D 792
Flammability	Self-extinguishing	ASTM D 635
Tensile Strength, yield, PSI	8500 minimum	ASTM D 638
Izod impact strength, ft-lb/in [notched, 1/8 inch]	12 minimum	ASTM D 256

For pole mounting, provide side of pole mounting assemblies with framework and all other hardware necessary to make complete, watertight connections of the signal heads to the poles and pedestals. Fabricate the mounting assemblies and frames from aluminum with all necessary

hardware, screws, washers, etc. to be stainless steel. Provide mounting fittings that match the positive locking device on the signal head with the serrations integrally cast into the brackets. Provide upper and lower pole plates that have a 1 ¼-inch vertical conduit entrance hubs with the hubs capped on the lower plate and 1 ½-inch horizontal hubs. Ensure that the assemblies provide rigid attachments to poles and pedestals so as to allow no twisting or swaying of the signal heads. Ensure that all raceways are free of sharp edges and protrusions, and can accommodate a minimum of ten Number 14 AWG conductors.

For pedestal mounting, provide a post-top slipfitter mounting assembly that matches the positive locking device on the signal head with serrations integrally cast into the slipfitter. Provide stainless steel hardware, screws, washers, etc. Provide a minimum of six 3/8 X 3/4-inch long square head bolts for attachment to pedestal. Provide a center post for multi-way slipfitters.

For light emitting diode (LED) traffic signal modules, provide the following requirements for inclusion on the Department's Qualified Products List for traffic signal equipment.

1. Sample submittal,
2. Third-party independent laboratory testing results for each submitted module with evidence of testing and conformance with all of the Design Qualification Testing specified in section 6.4 of each of the following Institute of Transportation Engineers (ITE) specifications:
 - Vehicle Traffic Control Signal Heads – Light Emitting Diode (LED) Circular Signal Supplement
 - Vehicle Traffic Control Signal Heads – Light Emitting Diode (LED) Vehicle Arrow Traffic Signal Supplement
 - Pedestrian Traffic Control Signal Indications –Light Emitting Diode (LED) Signal Modules.

(Note: The Department currently recognizes two approved independent testing laboratories. They are Intertek ETL Semko and Light Metrics, Incorporated with Garwood Laboratories. Independent laboratory tests from other laboratories may be considered as part of the QPL submittal at the discretion of the Department,

3. Evidence of conformance with the requirements of these specifications,
4. A manufacturer's warranty statement in accordance with the required warranty, and
5. Submittal of manufacturer's design and production documentation for the model, including but not limited to, electrical schematics, electronic component values, proprietary part numbers, bill of materials, and production electrical and photometric test parameters.
6. Evidence of approval of the product to bear the Intertek ETL Verified product label for LED traffic signal modules.

Ensure LED traffic signal modules meet the performance requirements for the minimum period of 15 years, provide a written warranty against defects in materials and workmanship for the modules for a period of 15 years after installation of the modules. During the warranty period, the manufacturer must provide new replacement modules within 45 days of receipt of modules that have failed at no cost to the State. Repaired or refurbished modules may not be used to fulfill the manufacturer's warranty obligations. Provide manufacturer's warranty documentation to the Department during evaluation of product for inclusion on Qualified Products List (QPL).

B. Vehicle Signal Heads:

Comply with the ITE standard "Vehicle Traffic Control Signal Heads". Provide housings with provisions for attaching backplates.

Provide visors that are 8 inches in length for 8-inch vehicle signal head sections. Provide visors that are 10 inches in length for 12-inch vehicle signal heads.

Provide a termination block with one empty terminal for field wiring for each indication plus one empty terminal for the neutral conductor. Have all signal sections wired to the termination block. Provide barriers between the terminals that have terminal screws with a minimum Number 8 thread size and that will accommodate and secure spade lugs sized for a Number 10 terminal screw.

Mount termination blocks in the yellow signal head sections on all in-line vehicle signal heads. Mount the termination block in the red section on five-section vehicle signal heads.

Furnish vehicle signal head interconnecting brackets. Provide one-piece aluminum brackets less than 4.5 inches in height and with no threaded pipe connections. Provide hand holes on the bottom of the brackets to aid in installing wires to the signal heads. Lower brackets that carry no wires and are used only for connecting the bottom signal sections together may be flat in construction.

For messenger cable mounting, provide messenger cable hangers, wire outlet bodies, balance adjusters, bottom caps, wire entrance fitting brackets, and all other hardware necessary to make complete, watertight connections of the vehicle signal heads to the messenger cable. Fabricate messenger cable hanger components, wire outlet bodies and balance adjuster components from stainless steel or malleable iron galvanized in accordance with ASTM A153 (Class A) or ASTM A123. Provide serrated rings made of aluminum. Provide messenger cable hangers with U-bolt clamps. Fabricate washers, screws, hex-head bolts and associated nuts, clevis pins, cotter pins, U-bolt clamps and nuts from stainless steel.

For mast-arm mounting, provide rigid vehicle signal head mounting brackets and all other hardware necessary to make complete, watertight connections of the vehicle signal heads to the mast arms and to provide a means for vertically adjusting the vehicle signal heads to proper alignment. Fabricate the mounting assemblies from aluminum, and provide serrated rings made of aluminum. Provide stainless steel cable attachment assemblies to secure the brackets to the mast arms. Ensure all fastening hardware and fasteners are fabricated from stainless steel.

Provide LED vehicular traffic signal modules (hereafter referred to as modules) that consist of an assembly that uses LEDs as the light source in lieu of an incandescent lamp for use in traffic signal sections. Use LEDs that are aluminum indium gallium phosphorus (AlInGaP) technology for red and yellow indications and indium gallium nitride (InGaN) for green indications. Install the ultra bright type LEDs that are rated for 100,000 hours of continuous operation from -40°F to +165°F. Design modules to have a minimum useful life of 15 years and to meet all parameters of this specification during this period of useful life.

For the modules, provide spade terminals crimped to the lead wires and sized for a #10 screw connection to the existing terminal block in a standard signal head. Do not provide other types of crimped terminals with a spade adapter.

Ensure the power supply is integral to the module assembly. On the back of the module, permanently mark the date of manufacture (month & year) or some other method of identifying date of manufacture.

Tint the red, yellow and green lenses to correspond with the wavelength (chromaticity) of the LED. Transparent tinting films are unacceptable. Provide a lens that is integral to the unit with a smooth outer surface.

1. LED Circular Signal Modules:

Provide modules in the following configurations: 12-inch circular sections, and 8-inch circular sections. All makes and models of LED modules purchased for use on the State Highway System shall appear on the current NCDOT Traffic Signal Qualified Products List (QPL).

Provide the manufacturer’s model number and the product number (assigned by the Department) for each module that appears on the 2024 or most recent Qualified Products List. In addition, provide manufacturer’s certification in accordance with Article 106-3 of the *Standard Specifications*, that each module meets or exceeds the ITE “Vehicle Traffic Control Signal Heads – Light Emitting Diode (LED) Circular Signal Supplement” dated June 27, 2005 (hereafter referred to as VTCSH Circular Supplement) and other requirements stated in this specification.

Provide modules that meet the following requirements when tested under the procedures outlined in the VTCSH Circular Supplement:

Module Type	Max. Wattage at 165° F	Nominal Wattage at 77° F
12-inch red circular	17	11
8-inch red circular	13	8
12-inch green circular	15	15
8-inch green circular	12	12

For yellow circular signal modules, provide modules tested under the procedures outlined in the VTCSH Circular Supplement to insure power required at 77° F is 22 Watts or less for the 12-inch circular module and 13 Watts or less for the 8-inch circular module.

Note: Use a wattmeter having an accuracy of ±1% to measure the nominal wattage and maximum wattage of a circular traffic signal module. Power may also be derived from voltage, current and power factor measurements.

2. LED Arrow Signal Modules

Provide 12-inch omnidirectional arrow signal modules. All makes and models of LED modules purchased for use on the State Highway System shall appear on the current NCDOT Traffic Signal Qualified Products List (QPL).

Provide the manufacturer’s model number and the product number (assigned by the Department) for each module that appears on the 2024 or most recent Qualified Products List. In addition, provide manufacturer’s certification in accordance with Article 106-3 of the *Standard Specifications*, that each module meets or exceeds the requirements for 12-inch omnidirectional modules specified in the ITE “Vehicle Traffic Control Signal Heads – Light Emitting Diode (LED) Vehicle Arrow Traffic Signal Supplement” dated July 1, 2007 (hereafter referred to as VTCSH Arrow Supplement) and other requirements stated in this specification.

Provide modules that meet the following requirements when tested under the procedures outlined in the VTCSH Arrow Supplement:

Module Type	Max. Wattage at 165° F	Nominal Wattage at 77° F
12-inch red arrow	12	9
12-inch green arrow	11	11

For yellow arrow signal modules, provide modules tested under the procedures outlined in the VTCSH Arrow Supplement to insure power required at 77° F is 12 Watts or less.

Note: Use a wattmeter having an accuracy of $\pm 1\%$ to measure the nominal wattage and maximum wattage of an arrow traffic signal module. Power may also be derived from voltage, current and power factor measurements.

3. LED U-Turn Arrow Signal Modules:

Provide modules in the following configurations: 12-inch left u-turn arrow signal modules and 12-inch right u-turn arrow signal modules.

Modules are not required to be listed on the ITS and Signals Qualified Products List. Provide manufacturer’s certification in accordance with Article 106-3 of the *Standard Specifications*, that each module meets or exceeds the ITE “Vehicle Traffic Control Signal Heads – Light Emitting Diode (LED) Circular Signal Supplement” dated June 27, 2005 (hereafter referred to as VTCSH Circular Supplement) and other requirements stated in this specification.

Provide modules that have minimum maintained luminous intensity values that are not less than 16% of the values calculated using the method described in section 4.1 of the VTCSH Circular Supplement.

Provide modules that meet the following requirements when tested under the procedures outlined in the VTCSH Circular Supplement:

Module Type	Max. Wattage at 165° F	Nominal Wattage at 77° F
12-inch red u-turn arrow	17	11
12-inch green u-turn arrow	15	15

For yellow u-turn arrow signal modules, provide modules tested under the procedures outlined in the VTCSH Circular Supplement to ensure power required at 77° F is 22 Watts or less.

Note: Use a wattmeter having an accuracy of $\pm 1\%$ to measure the nominal wattage and maximum wattage of a circular traffic signal module. Power may also be derived from voltage, current and power factor measurements.

4. LED Bi-Modal Green-Yellow Arrow Signal Modules

Provide 12-inch omnidirectional bi-modal arrow signal modules. Ensure both green and yellow arrow indications are in each module with a clear lens that is integral to the unit. Ensure both indications display an incandescent style look.

Modules are not required to be listed on the ITS and Signals Qualified Products List. Ensure that both indications along with the module meet or exceed the requirements in sections 1, 2, 3, 4 and 5 of the VTCSH Arrow Supplement and other requirements stated in this specification.

Provide modules that meet the following requirements when tested under the procedures outlined in the VTCSH Arrow Supplement:

Arrow Type	Nominal Wattage at 77° F
12-inch yellow arrow	12
12-inch green arrow	11

Note: Use a wattmeter having an accuracy of $\pm 1\%$ to measure the nominal wattage and maximum wattage of a circular traffic signal module. Power may also be derived from voltage, current and power factor measurements.

C. Pedestrian Signal Heads:

Provide pedestrian signal heads with international symbols that meet the MUTCD. Do not provide letter indications.

Comply with the ITE standard for “Pedestrian Traffic Control Signal Indications” and the following sections of the ITE standard for “Vehicle Traffic Control Signal Heads” in effect on the date of advertisement:

- Section 3.00 - “Physical and Mechanical Requirements”
- Section 4.01 - “Housing, Door, and Visor: General”
- Section 4.04 - “Housing, Door, and Visor: Materials and Fabrication”
- Section 7.00 - “Exterior Finish”

Provide a double-row termination block with three empty terminals and number 10 screws for field wiring. Provide barriers between the terminals that accommodate a spade lug sized for number 10 terminal screws. Mount the termination block in the hand section. Wire all signal sections to the terminal block.

Where required by the plans, provide 16-inch pedestrian signal heads with traditional three-sided, rectangular visors, 6 inches long. Where required by the plans, provide 12-inch pedestrian signal heads with traditional three-sided, rectangular visors, 8 inches long.

Provide 2-inch diameter pedestrian push-buttons with weather-tight housings fabricated from die-cast aluminum and threading in compliance with the NEC for rigid metal conduit. Provide a weep hole in the housing bottom and ensure that the unit is vandal resistant.

Provide push-button housings that are suitable for mounting on flat or curved surfaces and that will accept 1/2-inch conduit installed in the top. Provide units that have a heavy duty push-button assembly with a sturdy, momentary, normally-open switch. Have contacts that are electrically insulated from the housing and push-button. Ensure that the push-buttons are rated for a minimum of 5 mA at 24 volts DC and 250 mA at 12 volts AC.

Provide standard R10-3 signs with mounting hardware that comply with the MUTCD in effect on the date of advertisement. Provide R10-3E signs for countdown pedestrian heads and R10-3B for non-countdown pedestrian heads.

Design the LED pedestrian traffic signal modules (hereafter referred to as modules) for installation into standard pedestrian traffic signal sections that do not contain the incandescent signal section reflector, lens, eggcrate visor, gasket, or socket. Provide modules that consist of an assembly that uses LEDs as the light source in lieu of an incandescent lamp. Use LEDs that are of the latest aluminum indium gallium phosphorus (AlInGaP) technology for the Portland Orange hand and countdown displays. Use LEDs that are of the latest indium gallium nitride (InGaN) technology for the Lunar White walking man displays. Install the ultra-bright type LEDs that are rated for 100,000 hours of continuous operation from -40°F to +165°F. Design modules to have a minimum useful life of 60 months and to meet all parameters of this specification during this period of useful life.

Design all modules to operate using a standard 3 - wire field installation. Provide spade terminals crimped to the lead wires and sized for a #10 screw connection to the existing terminal block in a standard pedestrian signal housing. Do not provide other types of crimped terminals with a spade adapter.

Ensure the power supply is integral to the module assembly. On the back of the module, permanently mark the date of manufacture (month & year) or some other method of identifying date of manufacture.

Provide modules in the following configuration: 16-inch displays which have the solid hand/walking man overlay on the left and the countdown on the right, and 12-inch displays which have the solid hand/walking man module as an overlay. All makes and models of LED modules purchased for use on the State Highway System shall appear on the current NCDOT Traffic Signal Qualified Products List (QPL).

Provide the manufacturer’s model number and the product number (assigned by the Department) for each module that appears on the 2024 or most recent Qualified Products List. In addition, provide manufacturer’s certification in accordance with Article 106-3 of the *Standard Specifications*, that each module meets or exceeds the ITE “Pedestrian Traffic Control Signal Indicators - Light Emitting Diode (LED) Signal Modules” dated August 04, 2010 (hereafter referred to as PTCSI Pedestrian Standard) and other requirements stated in this specification.

Provide modules that meet the following requirements when tested under the procedures outlined in the PTCSI Pedestrian Standard:

Module Type	Max. Wattage at 165° F	Nominal Wattage at 77° F
Hand Indication	16	13
Walking Man Indication	12	9
Countdown Indication	16	13

Note: Use a wattmeter having an accuracy of ±1% to measure the nominal wattage and maximum wattage of a circular traffic signal module. Power may also be derived from voltage, current and power factor measurements.

Provide module lens that is hard coated or otherwise made to comply with the material exposure and weathering effects requirements of the Society of Automotive Engineers (SAE) J576. Ensure all exposed components of the module are suitable for prolonged exposure to the environment, without appreciable degradation that would interfere with function or appearance.

Ensure the countdown display continuously monitors the traffic controller to automatically learn the pedestrian phase time and update for subsequent changes to the pedestrian phase time.

Ensure the countdown display begins normal operation upon the completion of the preemption sequence and no more than one pedestrian clearance cycle.

D. Bus Rapid Transit Signal Heads:

Provide modules in the following configurations, 12-inch three lens signal head assemblies per the MUTCD, Figure 8C-3. The 12-inch LED optical unit indications must comply with the MUTCD, Section 8C.11 and as illustrated in Figure 8C-3.

Provide LED transit signal modules that conform to the requirements of the ITE’s Performance Specification, Vehicle Traffic Control Signal Heads-Light Emitting Diode (LED) Circular Signal Supplement, dated June 27, 2005, regarding environmental requirements, transient protection, operating voltage range, and electronic noise. The indication (bar symbol) must measure 1-1/2 inches wide by 9 inches long. The indication must be capable of being displayed in any angle of orientation from horizontal to vertical. Modules are not required to be listed on the ITS and Signals Qualified Products List.

12-inch three lens

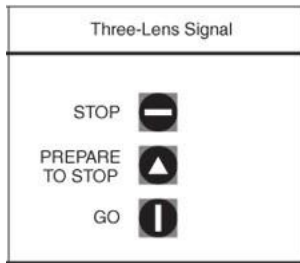

E. Optically-Programmed Vehicle Signal Sections:

Material, equipment, and hardware furnished under this section must be pre-approved on the Department's QPL by the date of installation.

Design the programmable signal sections to tilt in two degree increments for a maximum of ten degrees above and ten degrees below horizontal, while still maintaining a common vertical axis.

Design the programmable signal sections to mount to standard signal sections to form a signal head. Ensure that the programmable signal sections have a mounting system compatible with the standard 1 1/2-inch traffic signal fittings.

Provide an optical system consisting of a lamp, a diffuser, an optical limiter, and an objective lens. Ensure that all programming is accomplished optically with no hoods or louvers necessary to accomplish the programming. Provide optical masking tape with each section.

Provide a 150-Watt, 115 VAC lamp with integral reflector and rated output of 1750 lumens. Ensure that the average rated life is at least 6000 hours.

Provide a high resolution, annular, incremental lens. Ensure that the lens and door are sealed to provide a moisture and dust proof seal. Provide a red, yellow, or green ball or arrow indication as specified by the bid list, plans, or purchase order.

F. Louvers:

Material, equipment, and hardware furnished under this section must be pre-approved on the Department's QPL by the date of installation.

Provide louvers made from sheet aluminum. Paint the louvers alkyd urea black synthetic baked enamel with a minimum gloss reflectance and meeting the requirements of MIL-E-10169, "Enamel Heat Resisting, Instrument Black."

Ensure that the louvers have a 0-degree horizontal viewing angle. Provide a minimum of 5 vanes.

3. LED BLANKOUT SIGN

3.1. MATERIALS

Provide a message display that is a PCB matrix with a matte black solder mask with minimum thickness of 0.093 inches and a silk-screened component identifier. Mount LEDs on front of the PCB matrix. Mount all other components on the back of the black matrix. Ensure that a person with 20/20 vision can read a fully intensified, legible message from 500 feet in front of the sign under any light conditions. Ensure the message is not legible when the sign is off, even if in direct sunlight.

Use white LEDs that are the latest InGaN technology or better with a minimum luminous intensity of 6,000 mcd at 20 mA. Distribute the LEDs evenly. Connect the individual LED light sources so that failure of a single LED will result in a loss of no more than 5 LEDs. Ensure the sign is still legible.

Protect and seal the rear side of the PCB with a molded polymeric back cover. Mount the display PCB with back cover into the front door, which consists of an aluminum frame and face lens.

Provide a clear 0.25-inch, non-glare, matte finish polycarbonate lens with a UV resistant surface treatment. Ensure that the lens has light transmission properties equal to or greater than 80%.

Fabricate the weatherproof housing out of 0.125 inch aluminum with all corner seams welded their full length. Weld the full length of all corner seams using tungsten inert gas method. Install a terminal block that accommodates a spade lug sized for a number 10 terminal screw. Provide 4 terminals with each having 2 terminal screws that have a shorting bar between them. Fabricate an entrance for wires on top-center of the housing that is compatible to connect a standard traffic signal mounting gooseneck (wire entrance).

Provide a standard sun visor made of 1/16-inch aluminum. Paint the inside of the visor with 2 coats of dull black paint. Paint the exterior and interior of the sign case and the outside of the visor Federal Standard 595C yellow by the dry powder method. Apply the yellow finish by electrostatic spray and heat cure. Ensure the thickness of the finish is a minimum of 2.5 mils thick. Do not apply paint to the latching hardware.

Ensure that the LED current does not exceed the manufacturer's maximum current rating. Provide voltage surge protection to withstand high repetition noise transients and low repetition high energy transients as stated in section 2.1.6 of the NEMA Standard TS-2, 2021.

Ensure compatibility and proper triggering and operation with load switches and conflict monitors in signal controllers currently used by the Department. Ensure the on-board circuitry meets FCC title 47, sub-part B, section 15 regulations on the emission of electronic noise.

Design and certify the LED blank out sign to operate over a temperature range of -35°F to 165°F with an operating voltage range of 105 to 130 volts. Ensure that all electronic components are standard industry items that are available from wholesale electronics distributors. Provide components that are "solid state" type. Do not use electro-mechanical components.

4. CONTROLLERS WITH CABINETS

4.1. MATERIALS – TYPE 170E CONTROLLERS

Conform to the CALTRANS *Traffic Signal Control Equipment Specifications* and addendum 8, *Specifications for Model 170E Enhanced Controller Unit and Associated Model 412C and Model 172 Modules* except as required herein.

Provide model 412C Program Modules as defined in CALTRANS Addendum 8 except as specified otherwise herein. Provide program module delivery with Memory Select #4 Configuration except that all RAM must be DALLAS Non-volatile RAM or an approved equal. Ensure that the removal of the program module from the controller will place the intersection into flash.

Provide diagnostic software or removable diagnostic PROM modules that will test and diagnose the following:

- systems of the controller, including the internal memory, Program Module, Real Time Clock, I/O circuitry, display, and keyboard;
- systems of the cabinet, including the output file, input file, police panel, flashing operation, and cabinet switches; and
- systems of the conflict monitor by checking all possible conflicts in a logical sequence and resetting the conflict monitor each time, and by testing red failure function and red detect cable disconnects.

Ensure that the automatic reset function can be enabled by inserting a diagnostic plug in the jack labeled "Conflict Monitor Test" in the "TEST" position.

In addition to CALTRANS system communications capability between a central computer and master controller and master to local controller communications, provide communications capability with the intersection conflict monitor via an RS-232C/D port on the monitor. Ensure controller receives data from the conflict monitor through a controller Asynchronous Communications Interface Adapter (ACIA) determined by the controller software manufacturer. Ensure that with the appropriate software, the controller is capable of communicating directly through a laptop nine pin serial port to the same monitor RS-232C/D to retrieve all event log information.

Furnish a communications connecting cable with the following pin connections.

170		Conflict Monitor DB-9
RX pin L	Connect to	TX pin 2
TX pin K	Connect to	RX pin 3
+5 pin D	Connect to	DTR pin 4
GND pin N	Connect to	GND pin 5

Provide a male DB-9 connector on the cable for connection to the monitor.

Provide socket mounting for through-hole mount devices with 14 or more pins. Ensure that all sockets are AUGAT-500 series machined sockets, or equal.

Provide a moisture resistant coating on all circuit boards. Mount circuit boards vertically.

4.2. MATERIALS – TYPE 2070L CONTROLLERS

Conform to CALTRANS *Transportation Electrical Equipment Specifications (TEES)* (dated August 16, 2002, plus Errata 1 dated October 27, 2003 and Errata 2 dated June 08, 2004) except as required herein.

Furnish Model 2070L controllers. Ensure that removal of the CPU module from the controller will place the intersection into flash.

The Department will provide software at the beginning of the burning-in period. Contractor shall give 5 working days notice before needing software. Program software provided by the Department.

Provide model 2070L controllers with the latest version of OS9 operating software and device drivers, composed of the unit chassis and at a minimum the following modules and assemblies:

- MODEL 2070 1B, CPU Module, Single Board
- MODEL 2070-2A, Field I/O Module (FI/O)
 - Note: Configure the Field I/O Module to disable both the External WDT Shunt/Toggle Switch and SP3 (SP3 active indicator is “off”)
- MODEL 2070-3B, Front Panel Module (FP), Display B (8x40)
- MODEL 2070-4A, Power Supply Module, 10 AMP
- MODEL 2070-7A, Async Serial Com Module (9-pin RS-232)

Furnish one additional MODEL 2070-7A, Async Serial Com Module (9-pin RS-232) for all master controller locations.

For each master location and central control center, furnish a U.S. Robotics V.92 or approved equivalent auto-dial/auto-answer external modem to accomplish the interface to the Department-furnished microcomputers. Include all necessary hardware to ensure telecommunications.

4.3. MATERIALS – NEMA TS-1 CONTROLLERS

Furnish NEMA TS-1 controller (*insert model number here*), or approved equivalent. Include a NEMA standard overlap card.

Ensure that all components are arranged for easy access during servicing. When modular in construction, provide guides and positive connection devices to insure proper pin alignment and connection.

Provide a moisture resistant coating on all circuit boards.

4.4. MATERIALS – NEMA TS-2 TYPE 2 CONTROLLERS

Furnish NEMA TS-2, Type 2 (*insert model number here*), or approved equivalent. Include a NEMA standard overlap card.

Ensure that all components are arranged for easy access during servicing. When modular in construction, provide guides and positive connection devices to insure proper pin alignment and connection.

Provide a moisture resistant coating on all circuit boards.

4.5. MATERIALS – TYPE 2070E CONTROLLERS

Furnish model 2070E controller units that conform to CALTRANS *Transportation Electrical Equipment Specifications* (TEES) (dated March 12, 2009, plus Errata 1 dated January 21, 2010 and Errata 2 dated December 5, 2014) except as required herein.

The Department will provide software at the beginning of the burning-in period. Contractor shall give 5 working days notice before needing software. Program software provided by the Department.

Provide model 2070E controllers with OS-9 release 1.3.1 or later with kernel edition #380 or later operating software and device drivers, composed of the unit chassis and at a minimum the following modules and assemblies:

- MODEL 2070-1E, CPU Module, Single Board, with 8Mb Datakey (blue in color)
- MODEL 2070-2E+, Field I/O Module (FI/O)
 - Note: Configure the Field I/O Module to disable both the External WDT Shunt/Toggle Switch and SP3 (SP3 active indicator is “off”)
- MODEL 2070-3B, Front Panel Module (FP), Display B (8x40)
- MODEL 2070-4A, Power Supply Module, 10 AMP
- MODEL 2070-7A, Async Serial Com Module (9-pin RS-232)

4.6. MATERIALS – DEPARTMENT FURNISHED TYPE 2070 CONTROLLERS

Install 2070 controller furnished by the Department in a contractor supplied 170 cabinet that meets the material requirements of this Project Special Provision.

The Department will provide controller at the beginning of the burning-in period. Contractor shall give 5 working days notice before needing the controller.

4.7. MATERIALS – TYPE 2070LX CONTROLLERS

Furnish model 2070LX controller units that conform to CALTRANS *Transportation Electrical Equipment Specifications* (TEES) (dated March 12, 2009, plus Errata 1 dated January 21, 2010 and Errata 2 dated December 5, 2014) except as required herein.

The Department will provide software at the beginning of the burning-in period. Contractor shall give 5 working days notice before needing software. Program software provided by the Department.

Provide model 2070LX controllers with Linux kernel 2.6.18 or higher and device drivers, composed of the unit chassis and at a minimum the following modules and assemblies:

- MODEL 2070-1C, CPU Module, Single Board, with 8Mb Datakey (blue in color)
- MODEL 2070-2E+, Field I/O Module (FI/O)
 - Note: Configure the Field I/O Module to disable both the External WDT Shunt/Toggle Switch and SP3 (SP3 active indicator is “off”)
- MODEL 2070-3B, Front Panel Module (FP), Display B (8x40)
- MODEL 2070-4A, Power Supply Module, 10 AMP

Provide a Board Support Package (BSP) to the state and to any specified applications software manufacturer when requested by the state to facilitate the porting of application software.

4.8.MATERIALS – GENERAL CABINETS

Provide a moisture resistant coating on all circuit boards.

Provide one 20 mm diameter radial lead UL-recognized metal oxide varistor (MOV) between each load switch field terminal and equipment ground. Electrical performance is outlined below.

PROPERTIES OF MOV SURGE PROTECTOR	
Maximum Continuous Applied Voltage at 185° F	150 VAC (RMS) 200 VDC
Maximum Peak 8x20µs Current at 185° F	6500 A
Maximum Energy Rating at 185° F	80 J
Voltage Range 1 mA DC Test at 77° F	212-268 V
Max. Clamping Voltage 8x20µs, 100A at 77° F	395 V
Typical Capacitance (1 MHz) at 77° F	1600 pF

Provide a power line surge protector that is a two-stage device that will allow connection of the radio frequency interference filter between the stages of the device. Ensure that a maximum continuous current is at least 10A at 120V. Ensure that the device can withstand a minimum of 20 peak surge current occurrences at 20,000A for an 8x20 microsecond waveform. Provide a maximum clamp voltage of 395V at 20,000A with a nominal series inductance of 200µh. Ensure that the voltage does not exceed 395V. Provide devices that comply with the following:

Frequency (Hz)	Minimum Insertion Loss (dB)
60	0
10,000	30
50,000	55
100,000	50
500,000	50
2,000,000	60
5,000,000	40
10,000,000	20
20,000,000	25

4.9. MATERIALS – TYPE 170E CABINETS

A. Type 170 E Cabinets General:

Conform to the city of Los Angeles' Specification No. 54-053-08, *Traffic Signal Cabinet Assembly Specification* (dated July 2008), except as required herein.

Furnish model 336S pole mounted cabinets configured for 8 vehicle phases, 4 pedestrian phases, and 6 overlaps. Do not reassign load switches to accommodate overlaps unless shown on electrical details. Provide 336S pole mounted cabinets that are 46" high with 40" high internal rack assemblies.

Furnish model 332 base mounted cabinets configured for 8 vehicle phases, 4 pedestrian phases, and 6 overlaps. When overlaps are required, provide auxiliary output files for the overlaps. Do not reassign load switches to accommodate overlaps unless shown on electrical details.

Provide model 200 load switches, model 222 loop detector sensors, model 252 AC isolators, and model 242 DC isolators according to the electrical details. As a minimum, provide one (1) model 2018 conflict monitor, one (1) model 206L power supply unit, two (2) model 204 flashers, one (1) DC isolator (located in slot I14), and four (4) model 430 flash transfer relays (provide seven (7) model 430 flash transfer relays if auxiliary output file is installed) with each cabinet.

B. Type 170 E Cabinet Electrical Requirements:

Provide a cabinet assembly designed to ensure that upon leaving any cabinet switch or conflict monitor initiated flashing operation, the controller starts up in the programmed start up phases and start up interval.

Furnish two sets of non-fading cabinet wiring diagrams and schematics in a paper envelope or container and placed in the cabinet drawer.

All AC+ power is subject to radio frequency signal suppression.

Provide surge suppression in the cabinet for each type of cabinet device. Provide surge protection for the full capacity of the cabinet input file. Provide surge suppression devices that operate properly over a temperature range of -40° F to +185° F. Ensure the surge suppression devices provide both common and differential modes of protection.

Provide a pluggable power line surge protector that is installed on the back of the PDA (power distribution assembly) chassis to filter and absorb power line noise and switching transients. Ensure

the device incorporates LEDs for failure indication and provides a dry relay contact closure for the purpose of remote sensing. Ensure the device meets the following specifications:

- Peak Surge Current (Single pulse, 8x20µs).....20,000A
- Occurrences (8x20µs waveform).....10 minimum @ 20,000A
- Maximum Clamp Voltage.....395VAC
- Operating Current.....15 amps
- Response Time.....< 5 nanoseconds

Provide a loop surge suppressor for each set of loop terminals in the cabinet. Ensure the device meets the following specifications:

- Peak Surge Current (6 times, 8x20µs)
 - (Differential Mode).....400A
 - (Common Mode).....1,000A
- Occurrences (8x20µs waveform).....500 min @ 200A
- Maximum Clamp Voltage
 - (Differential Mode @400A).....35V
 - (Common Mode @1,000A).....35V
- Response Time.....< 5 nanoseconds
- Maximum Capacitance.....35 pF

Provide a data communications surge suppressor for each communications line entering or leaving the cabinet. Ensure the device meets the following specifications:

- Peak Surge Current (Single pulse, 8x20µs).....10,000A
- Occurrences (8x20µs waveform).....100 min @ 2,000A
- Maximum Clamp Voltage.....Rated for equipment protected
- Response Time.....< 1 nanosecond
- Maximum Capacitance.....1,500 pF
- Maximum Series Resistance.....15Ω

Provide a DC signal surge suppressor for each DC input channel in the cabinet. Ensure the device meets the following specifications:

- Peak Surge Current (Single pulse, 8x20µs).....10,000A
- Occurrences (8x20µs waveform).....100 @ 2,000A
- Maximum Clamp Voltage.....30V
- Response Time.....< 1 nanosecond

Provide a 120 VAC signal surge suppressor for each AC+ interconnect signal input. Ensure the device meets the following specifications:

- Peak Surge Current (Single pulse, 8x20µs).....20,000A
- Maximum Clamp Voltage.....350VAC
- Response Time.....< 200 nanoseconds
- Discharge Voltage.....<200 Volts @ 1,000A
- Insulation Resistance.....≥100 MΩ

Provide conductors for surge protection wiring that are of sufficient size (ampacity) to withstand maximum overcurrents which could occur before protective device thresholds are attained and current flow is interrupted.

If additional surge protected power outlets are needed to accommodate fiber transceivers, modems, etc., install a UL listed, industrial, heavy-duty type power outlet strip with a minimum rating of 15 A / 125 VAC, 60 Hz. Provide a strip that has a minimum of 3 grounded outlets. Ensure the power outlet strip plugs into one of the controller unit receptacles located on the rear of the PDA. Ensure power outlet strip is mounted securely; provide strain relief if necessary.

Provide a door switch in the front and a door switch in the rear of the cabinet that will provide the controller unit with a Door Ajar alarm when either the front or the rear door is open. Ensure the door switches apply DC ground to the Input File when either the front door or the rear door is open.

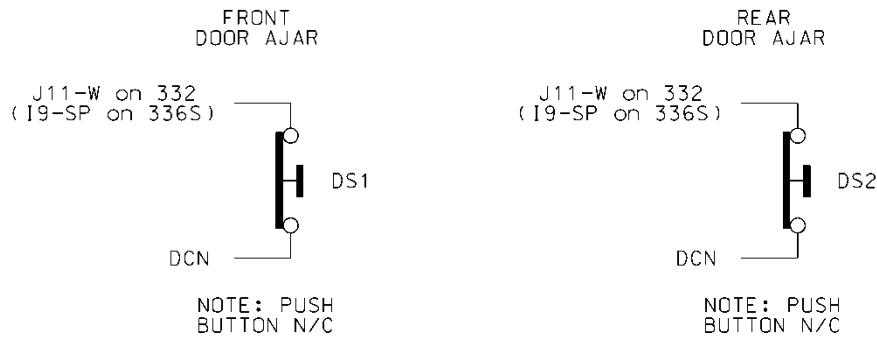

Furnish a fluorescent fixture in the rear across the top of the cabinet and another fluorescent fixture in the front across the top of the cabinet at a minimum. Ensure that the fixtures provide sufficient light to illuminate all terminals, labels, switches, and devices in the cabinet. Conveniently locate the fixtures so as not to interfere with a technician’s ability to perform work on any devices or terminals in the cabinet. Provide a protective diffuser to cover exposed bulbs. Install 16 watt T-4 lamps in the fluorescent fixtures. Provide a door switch to provide power to each fixture when the respective door is open. Wire the fluorescent fixtures to the 15 amp ECB (equipment circuit breaker).

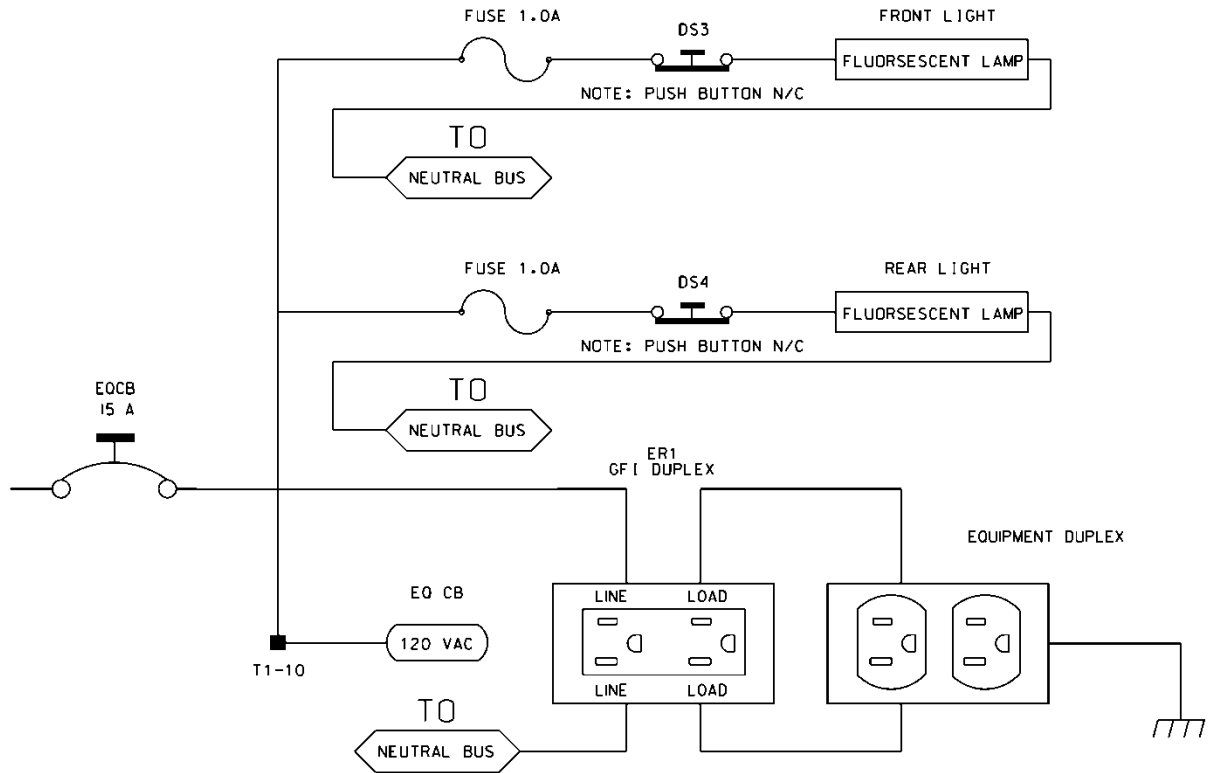

Furnish a police panel with a police panel door. For model 336S cabinets, mount the police panel on the rear door. Ensure that the police panel door permits access to the police panel when the main door is closed. Ensure that no rainwater can enter the cabinet even with the police panel door open. Provide a police panel door hinged on the right side as viewed from the front. Provide a police panel door lock that is keyed to a standard police/fire call box key. In addition to the requirements of LA Specification No. 54-053-08, provide the police panel with a toggle switch connected to switch the intersection operation between normal stop-and-go operation (AUTO) and manual operation (MANUAL). Ensure that manual control can be implemented using inputs and software such that the controller provides full programmed clearance times for the yellow clearance and red clearance for each phase while under manual control.

Provide a 1/4-inch locking phone jack in the police panel for a hand control to manually control the intersection. Provide sufficient room in the police panel for storage of a hand control and cord.

Ensure the 336S cabinet Input File is wired as follows:

336S Cabinet														
Port-Bit/C-1 Pin Assignment														
Slot #	1	2	3	4	5	6	7	8	9	10	11	12	13	14
C-1 (Spares)	59	60	61	62	63	64	65	66	75	76	77	78	79	80
Port C-1	3-2 56	1-1 39	3-4 58	1-3 41	3-1 55	1-2 40	3-3 57	1-4 42	2-5 51	5-5 71	5-6 72	5-1 67	5-2 68	6-7 81
Port C-1	2-1 47	1-5 43	2-3 49	1-7 45	2-2 48	1-6 44	2-4 50	1-8 46	2-6 52	5-7 73	5-8 74	5-3 69	5-4 70	6-8 82

For model 332 base mounted cabinets, ensure terminals J14-E and J14-K are wired together on the rear of the Input File. Connect TB9-12 (J14 Common) on the Input Panel to T1-2 (AC-) on the rear of the PDA.

Provide detector test switches mounted at the top of the cabinet rack or other convenient location which may be used to place a call on each of eight phases based on the chart below. Provide three positions for each switch: On (place call), Off (normal detector operation), and Momentary On (place momentary call and return to normal detector operation after switch is released). Ensure that the switches are located such that the technician can read the controller display and observe the intersection.

Connect detector test switches for cabinets as follows:

336S Cabinet		332 Cabinet	
Detector Call Switches	Terminals	Detector Call Switches	Terminals
Phase 1	I1-F	Phase 1	I1-W
Phase 2	I2-F	Phase 2	I4-W
Phase 3	I3-F	Phase 3	I5-W
Phase 4	I4-F	Phase 4	I8-W
Phase 5	I5-F	Phase 5	J1-W
Phase 6	I6-F	Phase 6	J4-W
Phase 7	I7-F	Phase 7	J5-W
Phase 8	I8-F	Phase 8	J8-W

Provide the PCB 28/56 connector for the conflict monitor unit (CMU) with 28 independent contacts per side, dual-sided with 0.156 inch contact centers. Provide the PCB 28/56 connector contacts with solder eyelet terminations. Ensure all connections to the PCB 28/56 connector are soldered to the solder eyelet terminations.

Ensure that all cabinets have the CMU connector wired according to the 332 cabinet connector pin assignments (include all wires for auxiliary output file connection). Wire pins 13, 16, R, and U of the CMU connector to a separate 4 pin plug, P1, as shown below. Provide a second plug, P2, which will mate with P1 and is wired to the auxiliary output file as shown below. Provide an additional plug, P3, which will mate with P1 and is wired to the pedestrian yellow circuits as shown

below. When no auxiliary output file is installed in the cabinet, provide wires for the green and yellow inputs for channels 11, 12, 17, and 18, the red inputs for channels 17 and 18, and the wires for the P2 plug. Terminate the two-foot wires with ring type lugs, insulated, and bundled for optional use.

PIN	P1		P2		P3	
	FUNCTION	CONN TO	FUNCTION	CONN TO	FUNCTION	CONN TO
1	CH-9G	CMU-13	OLA-GRN	A123	2P-YEL	114
2	CH-9Y	CMU-16	OLA-YEL	A122	4P-YEL	105
3	CH-10G	CMU-R	OLB-GRN	A126	6P-YEL	120
4	CH-10Y	CMU-U	OLB-YEL	A125	8P-YEL	111

Do not provide the P20 terminal assembly (red monitor board) or red interface ribbon cable as specified in LA Specification No. 54-053-08.

Provide a P20 connector that mates with and is compatible with the red interface connector mounted on the front of the conflict monitor. Ensure that the P20 connector and the red interface connector on the conflict monitor are center polarized to ensure proper connection. Ensure that removal of the P20 connector will cause the conflict monitor to recognize a latching fault condition and place the cabinet into flashing operation.

Wire the P20 connector to the output file and auxiliary output file using 22 AWG stranded wires. Ensure the length of these wires is a minimum of 42 inches in length. Provide a durable braided sleeve around the wires to organize and protect the wires.

Wire the P20 connector to the traffic signal red displays to provide inputs to the conflict monitor as shown below. Ensure the pedestrian Don't Walk circuits are wired to channels 13 through 16 of the P20 connector. When no auxiliary output file is installed in the cabinet, provide wires for channels 9 through 12 reds. Provide a wire for special function 1. Terminate the unused wires with ring type lugs, insulated, and bundled for optional use.

P20 Connector					
PIN	FUNCTION	CONN TO	PIN	FUNCTION	CONN TO
1	Channel 15 Red	119	2	Channel 16 Red	110
3	Channel 14 Red	104	4	Chassis GND	01-9
5	Channel 13 Red	113	6	N/C	
7	Channel 12 Red	AUX 101	8	Spec Function 1	
9	Channel 10 Red	AUX 124	10	Channel 11 Red	AUX 114
11	Channel 9 Red	AUX 121	12	Channel 8 Red	107
13	Channel 7 Red	122	14	Channel 6 Red	134
15	Channel 5 Red	131	16	Channel 4 Red	101
17	Channel 3 Red	116	18	Channel 2 Red	128
19	Channel 1 Red	125	20	Red Enable	01-14

Ensure the controller unit outputs to the auxiliary output file are pre-wired to the C5 connector. When no auxiliary output file is installed in the cabinet, connect the C5 connector to a storage socket located on the Input Panel or on the rear of the PDA.

Do not wire pin 12 of the load switch sockets.

In addition to the requirements of LA Specification No. 54-053-08, ensure relay K1 on the Power Distribution Assembly (PDA) is a four pole relay and K2 on the PDA is a two pole relay.

Provide a two pole, ganged circuit breaker for the flash bus circuit. Ensure the flash bus circuit breaker is an inverse time circuit breaker rated for 10 amps at 120 VAC with a minimum of 10,000 RMS symmetrical amperes short circuit current rating. Do not provide the auxiliary switch feature on the flash bus circuit breaker. Ensure the ganged flash bus circuit breaker is certified by the circuit breaker manufacturer to provide gang tripping operation.

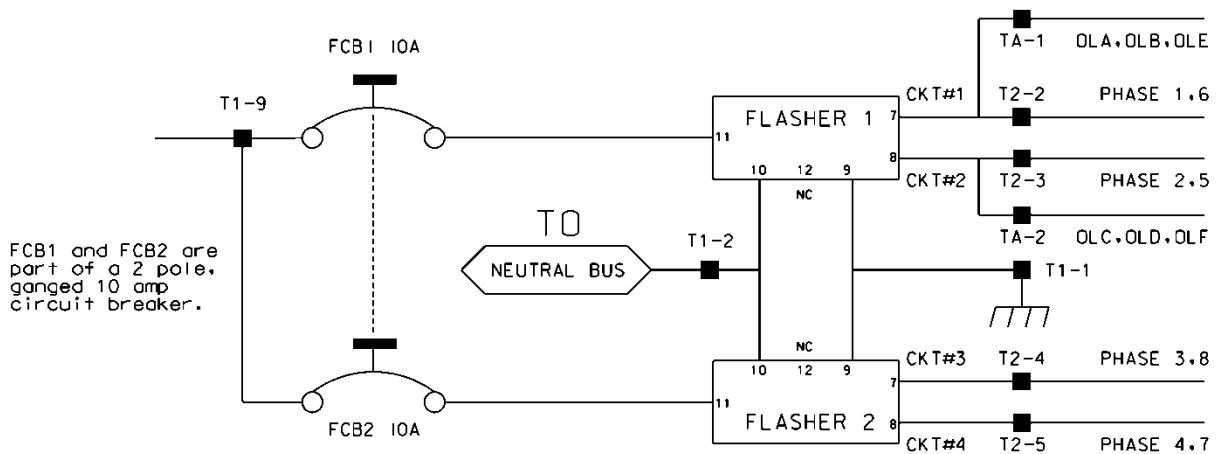

Ensure auxiliary output files are wired as follows:

AUXILIARY OUTPUT FILE TERMINAL BLOCK TA ASSIGNMENTS	
POSITION	FUNCTION
1	Flasher Unit #1, Circuit 1/FTR1 (OLA, OLB)/FTR3 (OLE)
2	Flasher Unit #1, Circuit 2/FTR2 (OLC, OLD)/FTR3 (OLF)
3	Flash Transfer Relay Coils
4	AC -
5	Power Circuit 5
6	Power Circuit 5
7	Equipment Ground Bus
8	NC

Provide four spare load resistors mounted in each cabinet. Ensure each load resistor is rated as shown in the table below. Wire one side of each load resistor to AC-. Connect the other side of each resistor to a separate terminal on a four (4) position terminal block. Mount the load resistors and terminal block either inside the back of Output File No. 1 or on the upper area of the Service Panel.

ACCEPTABLE LOAD RESISTOR VALUES	
VALUE (ohms)	WATTAGE
1.5K – 1.9 K	25W (min)
2.0K – 3.0K	10W (min)

Provide Model 200 load switches, Model 204 flashers, Model 242 DC isolators, Model 252 AC isolators, and Model 206L power supply units that conform to CALTRANS' "Transportation Electrical Equipment Specifications" dated March 12, 2009 with Erratum 1.

C. Type 170 E Cabinet Physical Requirements:

Do not mold, cast, or scribe the name "City of Los Angeles" on the outside of the cabinet door as specified in LA Specification No. 54-053-08. Do not provide a Communications Terminal Panel as specified in LA Specification No. 54-053-08. Do not provide terminal block TBB on the Service Panel. Do not provide Cabinet Verification Test Program software or associated test jigs as specified in LA Specification No. 54-053-08.

Furnish unpainted, natural, aluminum cabinet shells. Ensure that all non-aluminum hardware on the cabinet is stainless steel or a Department approved non-corrosive alternate.

Ensure the lifting eyes, gasket channels, police panel, and all supports welded to the enclosure and doors are fabricated from 0.125 inch minimum thickness aluminum sheet and meet the same standards as the cabinet and doors.

Provide front and rear doors with latching handles that allow padlocking in the closed position. Furnish 0.75 inch minimum diameter stainless steel handles with a minimum 0.5 inch shank. Place

the padlocking attachment at 4.0 inches from the handle shank center to clear the lock and key. Provide an additional 4.0 inches minimum gripping length.

Provide Corbin #2 locks on the front and rear doors. Provide one (1) Corbin #2 and one (1) police master key with each cabinet. Ensure main door locks allow removal of keys in the locked position only.

Provide a surge protection panel with 16 loop surge protection devices and designed to allow sufficient free space for wire connection/disconnection and surge protection device replacement. For model 332 cabinets, provide an additional 20 loop surge protection devices. Provide an additional two AC+ interconnect surge devices to protect one slot and eight DC surge protection devices to protect four slots. Provide no protection devices on slot I14.

For pole mounted cabinets, mount surge protection devices for the AC+ interconnect inputs, inductive loop detector inputs, and low voltage DC inputs on a swing down panel assembly fabricated from sturdy aluminum. Attach the swing down panel to the bottom rear cabinet rack assembly using thumb screws. Ensure the swing down panel allows for easy removal of the input file without removing the surge protection panel assembly or its parts. Have the surge protection devices mounted horizontally on the panel and soldered to the feed through terminals of four 14 position terminal blocks with #8 screws mounted on the other side. Ensure the top row of terminals is connected to the upper slots and the bottom row of terminals is connected to the bottom slots. Provide a 15 position copper equipment ground bus attached to the field terminal side (outside) of the swing down panel for termination of loop lead-in shield grounds. Ensure that a Number 4 AWG green wire connects the surge protection panel assembly ground bus to the main cabinet equipment ground.

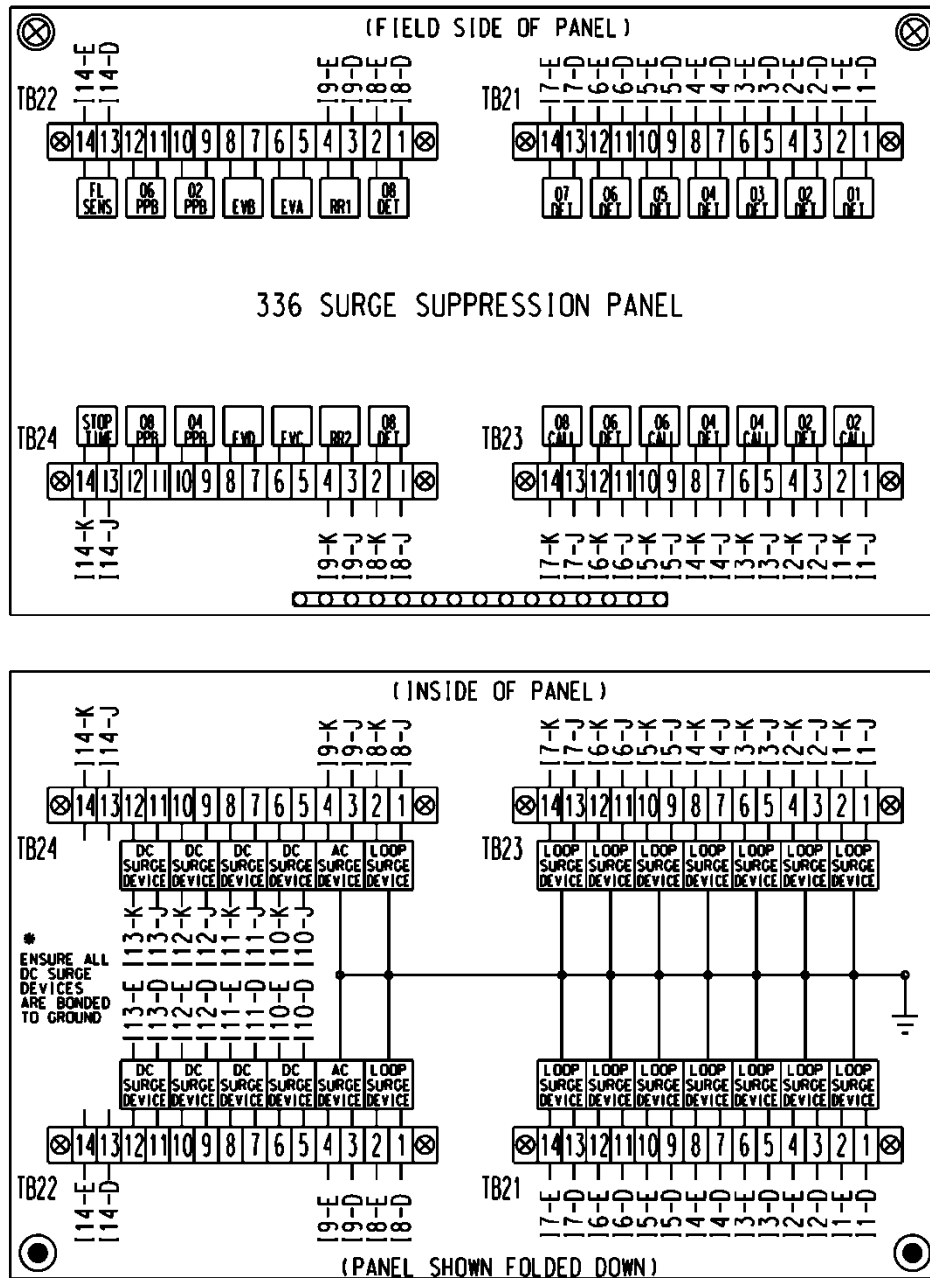

For base mounted cabinets, mount surge protection panels on the left side of the cabinet as viewed from the rear. Attach each panel to the cabinet rack assembly using bolts and make it easily removable. Mount the surge protection devices in vertical rows on each panel and connect the devices to one side of 12 position, double row terminal blocks with #8 screws. For each surge protection panel, terminate all grounds from the surge protection devices on a copper equipment ground bus attached to the surge protection panel. Wire the terminals to the rear of a standard input file using spade lugs for input file protection.

Provide permanent labels that indicate the slot and the pins connected to each terminal that may be viewed from the rear cabinet door. Label and orient terminals so that each pair of inputs is next to each other. Indicate on the labeling the input file (I or J), the slot number (1-14) and the terminal pins of the input slots (either D & E for upper or J & K for lower).

Provide a minimum 14 x 16 inch pull out, hinged top shelf located immediately below controller mounting section of the cabinet. Ensure the shelf is designed to fully expose the table surface outside the controller at a height approximately even with the bottom of the controller. Ensure the shelf has a storage bin interior which is a minimum of 1 inch deep and approximately the same dimensions as the shelf. Provide an access to the storage area by lifting the hinged top of the shelf. Fabricate the shelf and slide from aluminum or stainless steel and ensure the assembly can support the 2070L controller plus 15 pounds of additional weight. Ensure shelf has a locking mechanism to secure it in the fully extended position and does not inhibit the removal of the 2070L controller or removal of cards inside the controller when fully extended. Provide a locking mechanism that is easily released when the shelf is to be returned to its non-use position directly under the controller.

D. Model 2018 Enhanced Conflict Monitor:

Furnish Model 2018 Enhanced Conflict Monitors that provide monitoring of 18 channels. Ensure each channel consists of a green, yellow, and red field signal input. Ensure that the conflict monitor meets or exceeds CALTRANS' Transportation Electrical Equipment Specifications dated March 12, 2009, with Erratum 1 (hereafter referred to as CALTRANS' 2009 TEES) for a model 210 monitor unit and other requirements stated in this specification.

Ensure the conflict monitor is provided with an 18 channel conflict programming card. Pin EE and Pin T of the conflict programming card shall be connected together. Pin 16 of the conflict programming card shall be floating. Ensure that the absence of the conflict programming card will cause the conflict monitor to trigger (enter into fault mode), and remain in the triggered state until the programming card is properly inserted and the conflict monitor is reset.

Provide a conflict monitor that incorporates LED indicators into the front panel to dynamically display the status of the monitor under normal conditions and to provide a comprehensive review of field inputs with monitor status under fault conditions. Ensure that the monitor indicates the channels that were active during a conflict condition and the channels that experienced a failure for all other per channel fault conditions detected. Ensure that these indications and the status of each channel are retained until the Conflict Monitor is reset. Furnish LED indicators for the following:

- AC Power (Green LED indicator)
- VDC Failed (Red LED indicator)
- WDT Error (Red LED indicator)
- Conflict (Red LED indicator)
- Red Fail (Red LED indicator)
- Dual Indication (Red LED indicator)
- Yellow/Clearance Failure (Red LED indicator)
- PCA/PC Ajar (Red LED indicator)
- Monitor Fail/Diagnostic Failure (Red LED indicator)
- 54 Channel Status Indicators (1 Red, 1 Yellow, and 1 Green LED indicator for each of the 18 channels)

Provide a switch to set the Red Fail fault timing. Ensure that when the switch is in the ON position the Red Fail fault timing value is set to 1350 +/- 150 ms (2018 mode). Ensure that when the switch is in the OFF position the Red Fail fault timing value is set to 850 +/- 150 ms (210 mode).

Provide a switch to set the Watchdog fault timing. Ensure that when the switch is in the ON position the Watchdog fault timing value is set to 1.0 +/- 0.1 s (2018 mode). Ensure that when the switch is in the OFF position the Watchdog fault timing value is set to 1.5 +/- 0.1 s (210 mode).

Provide a jumper or switch to set the AC line brown-out levels. Ensure that when the jumper is present or the switch is in the ON position the AC line dropout voltage threshold is 98 +/- 2 Vrms, the AC line restore voltage threshold is 103 +/- 2 Vrms, and the AC line brown-out timing value is set to 400 +/- 50ms (2018 mode). Ensure that when the jumper is not present or the switch is in the OFF position the AC line dropout voltage threshold is 92 +/- 2 Vrms, the AC line restore voltage threshold is 98 +/- 2 Vrms, and the AC line brown-out timing value is set to 80 +/- 17 ms (210 mode).

Provide a jumper or switch that will enable and disable the Watchdog Latch function. Ensure that when the jumper is not present or the switch is in the OFF position the Watchdog Latch function is disabled. In this mode of operation, a Watchdog fault will be reset following a power loss, brownout, or power interruption. Ensure that when the jumper is present or the switch is in the ON position the Watchdog Latch function is enabled. In this mode of operation, a Watchdog fault will be retained until a Reset command is issued.

Provide a jumper that will reverse the active polarity for pin #EE (output relay common). Ensure that when the jumper is not present pin #EE (output relay common) will be considered 'Active' at a voltage greater than 70 Vrms and 'Not Active' at a voltage less than 50 Vrms (Caltrans mode). Ensure that when the jumper is present pin #EE (output relay common) will be considered 'Active' at a voltage less than 50 Vrms and 'Not Active' at a voltage greater than 70 Vrms (Failsafe mode).

In addition to the connectors required by CALTRANS' 2009 TEES, provide the conflict monitor with a red interface connector mounted on the front of the monitor. Ensure the connector is a 20 pin, right angle, center polarized, male connector with latching clip locks and polarizing keys. Ensure the right angle solder tails are designed for a 0.062" thick printed circuit board. Keying of the connector shall be between pins 3 and 5, and between 17 and 19. Ensure the connector has two rows of pins with the odd numbered pins on one row and the even pins on the other row. Ensure the connector pin row spacing is 0.10" and pitch is 0.10". Ensure the mating length of the connector pins is 0.24". Ensure the pins are finished with gold plating 30μ" thick.

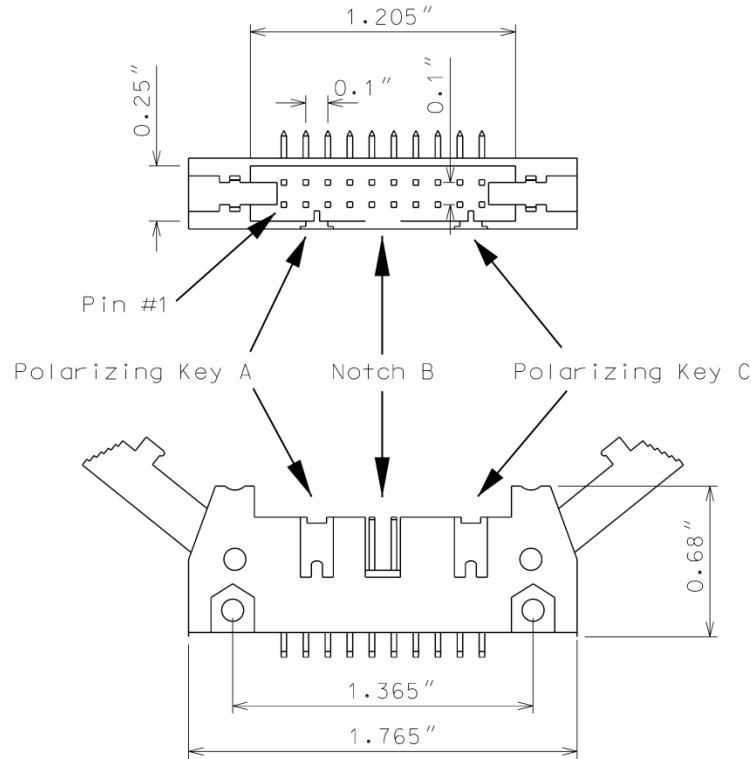

Ensure the red interface connector pins on the monitor have the following functions:

Pin #	Function	Pin #	Function
1	Channel 15 Red	2	Channel 16 Red
3	Channel 14 Red	4	Chassis Ground
5	Channel 13 Red	6	Special Function 2
7	Channel 12 Red	8	Special Function 1
9	Channel 10 Red	10	Channel 11 Red
11	Channel 9 Red	12	Channel 8 Red
13	Channel 7 Red	14	Channel 6 Red
15	Channel 5 Red	16	Channel 4 Red
17	Channel 3 Red	18	Channel 2 Red
19	Channel 1 Red	20	Red Enable

Ensure that removal of the P20 cable connector will cause the conflict monitor to recognize a latching fault condition and place the cabinet into flashing operation.

Provide Special Function 1 and Special Function 2 inputs to the unit which shall disable only Red Fail Monitoring when either input is sensed active. A Special Function input shall be sensed active when the input voltage exceeds 70 Vrms with a minimum duration of 550 ms. A Special Function input shall be sensed not active when the input voltage is less than 50 Vrms or the duration is less

than 250 ms. A Special Function input is undefined by these specifications and may or may not be sensed active when the input voltage is between 50 Vrms and 70 Vrms or the duration is between 250 ms and 550 ms.

Ensure the conflict monitor recognizes field signal inputs for each channel that meet the following requirements:

- consider a Red input greater than 70 Vrms and with a duration of at least 500 ms as an “on” condition;
- consider a Red input less than 50 Vrms or with a duration of less than 200 ms as an “off” condition (no valid signal);
- consider a Red input between 50 Vrms and 70 Vrms or with a duration between 200 ms and 500 ms to be undefined by these specifications;
- consider a Green or Yellow input greater than 25 Vrms and with a duration of at least 500 ms as an “on” condition;
- consider a Green or Yellow input less than 15 Vrms or with a duration of less than 200 ms as an “off” condition; and
- consider a Green or Yellow input between 15 Vrms and 25 Vrms or with a duration between 200 ms and 500 ms to be undefined by these specifications.

Provide a conflict monitor that recognizes the faults specified by CALTRANS’ 2009 TEES and the following additional faults. Ensure the conflict monitor will trigger upon detection of a fault and will remain in the triggered (in fault mode) state until the unit is reset at the front panel or through the external remote reset input for the following failures:

1. **Red Monitoring or Absence of Any Indication (Red Failure):** A condition in which no “on” voltage signal is detected on any of the green, yellow, or red inputs to a given monitor channel. If a signal is not detected on at least one input (R, Y, or G) of a conflict monitor channel for a period greater than 1000 ms when used with a 170 controller and 1500 ms when used with a 2070 controller, ensure monitor will trigger and put the intersection into flash. If the absence of any indication condition lasts less than 700 ms when used with a 170 controller and 1200 ms when used with a 2070 controller, ensure conflict monitor will not trigger. Red fail monitoring shall be enabled on a per channel basis by the use of switches located on the conflict monitor. Have red monitoring occur when all of the following input conditions are in effect:
 - a) Red Enable input to monitor is active (Red Enable voltages are “on” at greater than 70 Vrms, off at less than 50 Vrms, undefined between 50 and 70 Vrms), and
 - b) Neither Special Function 1 nor Special Function 2 inputs are active.
 - c) Pin #EE (output relay common) is not active
2. **Short/Missing Yellow Indication Fault (Clearance Error):** Yellow indication following a green is missing or shorter than 2.7 seconds (with ± 0.1 -second accuracy). If a channel fails to detect an “on” signal at the Yellow input for a minimum of 2.7 seconds (± 0.1 second) following the detection of an “on” signal at a Green input for that channel, ensure that the monitor triggers and generates a clearance/short yellow error fault indication. Short/missing

yellow (clearance) monitoring shall be enabled on a per channel basis by the use of switches located on the conflict monitor. This fault shall not occur when the channel is programmed for Yellow Inhibit, when the Red Enable signal is inactive or pin #EE (output relay common) is active.

3. **Dual Indications on the Same Channel:** In this condition, more than one indication (R,Y,G) is detected as “on” at the same time on the same channel. If dual indications are detected for a period greater than 500 ms, ensure that the conflict monitor triggers and displays the proper failure indication (Dual Ind fault). If this condition is detected for less than 200 ms, ensure that the monitor does not trigger. G-Y-R dual indication monitoring shall be enabled on a per channel basis by the use of switches located on the conflict monitor. G-Y dual indication monitoring shall be enabled for all channels by use of a switch located on the conflict monitor. This fault shall not occur when the Red Enable signal is inactive or pin #EE (output relay common) is active.
4. **Configuration Settings Change:** The configuration settings are comprised of (as a minimum) the permissive diode matrix, dual indication switches, yellow disable jumpers, any option switches, any option jumpers, and the Watchdog Enable switch. Ensure the conflict monitor compares the current configuration settings with the previous stored configuration settings on power-up, on reset, and periodically during operation. If any of the configuration settings are changed, ensure that the conflict monitor triggers and causes the program card indicator to flash. Ensure that configuration change faults are only reset by depressing and holding the front panel reset button for a minimum of three seconds. Ensure the external remote reset input does not reset configuration change faults.

Ensure the conflict monitor will trigger and the AC Power indicator will flash at a rate of $2 \text{ Hz} \pm 20\%$ with a 50% duty cycle when the AC Line voltage falls below the “drop-out” level. Ensure the conflict monitor will resume normal operation when the AC Line voltage returns above the “restore” level. Ensure the AC Power indicator will remain illuminated when the AC voltage returns above the “restore” level. Should an AC Line power interruption occur while the monitor is in the fault mode, then upon restoration of AC Line power, the monitor will remain in the fault mode and the correct fault and channel indicators will be displayed.

Provide a flash interval of at least 6 seconds and at most 16 seconds in duration following a power-up, an AC Line interruption, or a brownout restore. Ensure the conflict monitor will suspend all fault monitoring functions, close the Output relay contacts, and flash the AC indicator at a rate of $4 \text{ Hz} \pm 20\%$ with a 50% duty cycle during this interval. Ensure the termination of the flash interval after at least 6 seconds if the Watchdog input has made 5 transitions between the True and False state and the AC Line voltage is greater than the “restore” level. If the watchdog input has not made 5 transitions between the True and False state within 10 ± 0.5 seconds, the monitor shall enter a WDT error fault condition.

Ensure the conflict monitor will monitor an intersection with a minimum of four approaches using the four-section Flashing Yellow Arrow (FYA) vehicle traffic signal as outlined by the NCHRP 3-54 research project for protected-permissive left turn signal displays. Ensure the conflict monitor will operate in the FYA mode and FYAc (Compact) mode as specified below to monitor each channel pair for the following fault conditions: Conflict, Flash Rate Detection, Red Fail, Dual Indication, and

Clearance. Provide a switch to select between the FYA mode and FYAc mode. Provide a switch to select each FYA phase movement for monitoring.

FYA mode

FYA Signal Head	Phase 1	Phase 3	Phase 5	Phase 7
Red Arrow	Channel 9 Red	Channel 10 Red	Channel 11 Red	Channel 12 Red
Yellow Arrow	Channel 9 Yellow	Channel 10 Yellow	Channel 11 Yellow	Channel 12 Yellow
Flashing Yellow Arrow	Channel 9 Green	Channel 10 Green	Channel 11 Green	Channel 12 Green
Green Arrow	Channel 1 Green	Channel 3 Green	Channel 5 Green	Channel 7 Green

FYAc mode

FYA Signal Head	Phase 1	Phase 3	Phase 5	Phase 7
Red Arrow	Channel 1 Red	Channel 3 Red	Channel 5 Red	Channel 7 Red
Yellow Arrow	Channel 1 Yellow	Channel 3 Yellow	Channel 5 Yellow	Channel 7 Yellow
Flashing Yellow Arrow	Channel 1 Green	Channel 3 Green	Channel 5 Green	Channel 7 Green
Green Arrow	Channel 9 Green	Channel 9 Yellow	Channel 10 Green	Channel 10 Yellow

If a FYA channel pair is enabled for FYA operation, the conflict monitor will monitor the FYA logical channel pair for the additional following conditions:

1. **Conflict:** Channel conflicts are detected based on the permissive programming jumpers on the program card. This operation remains unchanged from normal operation except for the solid Yellow arrow (FYA clearance) signal.
2. **Yellow Change Interval Conflict:** During the Yellow change interval of the Permissive Turn channel (flashing Yellow arrow) the conflict monitor shall verify that no conflicting channels to the solid Yellow arrow channel (clearance) are active. These conflicting channels shall be determined by the program card compatibility programming of the Permissive Turn channel (flashing Yellow arrow). During the Yellow change interval of the Protected Turn channel (solid Green arrow) the conflict monitor shall verify that no conflicting channels to the solid Yellow arrow channel (clearance) are active as determined by the program card compatibility programming of the Protected Turn channel (solid Green arrow).

3. **Flash Rate Detection:** The conflict monitor unit shall monitor for the absence of a valid flash rate for the Permissive turn channel (flashing Yellow arrow). If the Permissive turn channel (flashing Yellow arrow) is active for a period greater than 1600 milliseconds, ensure the conflict monitor triggers and puts the intersection into flash. If the Permissive turn channel (flashing Yellow arrow) is active for a period less than 1400 milliseconds, ensure the conflict monitor does not trigger. Ensure the conflict monitor will remain in the triggered (in fault mode) state until the unit is reset at the front panel or through the external remote reset input. Provide a jumper or switch that will enable and disable the Flash Rate Detection function. Ensure that when the jumper is not present or the switch is in the OFF position the Flash Rate Detection function is enabled. Ensure that when the jumper is present or the switch is in the ON position the Flash Rate Detection function is disabled.
4. **Red Monitoring or Absence of Any Indication (Red Failure):** The conflict monitor unit shall detect a red failure if there is an absence of voltage on all four of the inputs of a FYA channel pair (RA, YA, FYA, GA).
5. **Dual Indications on the Same Channel:** The conflict monitor unit shall detect a dual indication if two or more inputs of a FYA channel pair (RA, YA, FYA, GA) are “on” at the same time.
6. **Short/Missing Yellow Indication Fault (Clearance Error):** The conflict monitor unit shall monitor the solid Yellow arrow for a clearance fault when terminating both the Protected Turn channel (solid Green arrow) interval and the Permissive Turn channel (flashing Yellow arrow) interval.

Ensure that the conflict monitor will log at least nine of the most recent events detected by the monitor in non-volatile EEPROM memory (or equivalent). For each event, record at a minimum the time, date, type of event, status of each field signal indication with RMS voltage, and specific channels involved with the event. Ensure the conflict monitor will log the following events: monitor reset, configuration, previous fault, and AC line. Furnish the signal sequence log that shows all channel states (Greens, Yellows, and Reds) and the Red Enable State for a minimum of 2 seconds prior to the current fault trigger point. Ensure the display resolution of the inputs for the signal sequence log is not greater than 50 ms.

For conflict monitors used within an Ethernet communications system, provide a conflict monitor with an Ethernet 10/100 Mbps, RJ-45 port for data communication access to the monitor by a local notebook computer and remotely via a workstation or notebook computer device connected to the signal system local area network. The Ethernet port shall be electrically isolated from the conflict monitor’s electronics and shall provide a minimum of 1500 Vrms isolation. Integrate monitor with Ethernet network in cabinet. Provide software to retrieve the time and date from a network server in order to synchronize the on-board times between the conflict monitor and the controller. Furnish and install the following Windows based, graphic user interface software on workstations and notebook computers where the signal system client software is installed: 1) software to view and retrieve all event log information, 2) software that will search and display a list of conflict monitor IP addresses and IDs on the network, and 3) software to change the conflict monitor’s network parameters such as IP address and subnet mask.

For non-Ethernet connected monitors, provide a RS-232C/D compliant port (DB-9 female connector) on the front panel of the conflict monitor in order to provide communications from the conflict monitor to the 170/2070 controller or to a Department-furnished laptop computer. Electrically isolate the port interface electronics from all monitor electronics, excluding Chassis Ground. Ensure that the controller can receive all event log information through a controller

Asynchronous Communications Interface Adapter (Type 170E) or Async Serial Comm Module (2070). Furnish and connect a serial cable from the conflict monitor's DB-9 connector to Comm Port 1 of the 2070 controller. Ensure conflict monitor communicates with the controller. Provide a Windows based graphic user interface software to communicate directly through the same monitor RS-232C/D compliant port to retrieve and view all event log information to a Department-furnished laptop computer. The RS-232C/D compliant port on the monitor shall allow the monitor to function as a DCE device with pin connections as follows:

Conflict Monitor RS-232C/D (DB-9 Female) Pinout		
Pin Number	Function	I/O
1	DCD	O
2	TX Data	O
3	RX Data	I
4	DTR	I
5	Ground	-
6	DSR	O
7	CTS	I
8	RTS	O
9	NC	-

MONITOR BOARD EDGE CONNECTOR

Pin #	Function (Back Side)	Pin #	Function (Component Side)
1	Channel 2 Green	A	Channel 2 Yellow
2	Channel 13 Green	B	Channel 6 Green
3	Channel 6 Yellow	C	Channel 15 Green
4	Channel 4 Green	D	Channel 4 Yellow
5	Channel 14 Green	E	Channel 8 Green
6	Channel 8 Yellow	F	Channel 16 Green
7	Channel 5 Green	H	Channel 5 Yellow
8	Channel 13 Yellow	J	Channel 1 Green
9	Channel 1 Yellow	K	Channel 15 Yellow
10	Channel 7 Green	L	Channel 7 Yellow
11	Channel 14 Yellow	M	Channel 3 Green
12	Channel 3 Yellow	N	Channel 16 Yellow
13	Channel 9 Green	P	Channel 17 Yellow
14	Channel 17 Green	R	Channel 10 Green
15	Channel 11 Yellow	S	Channel 11 Green
16	Channel 9 Yellow	T	Channel 18 Yellow
17	Channel 18 Green	U	Channel 10 Yellow
--		--	
18	Channel 12 Yellow	V	Channel 12 Green
19	Channel 17 Red	W	Channel 18 Red
20	Chassis Ground	X	Not Assigned
21	AC-	Y	DC Common
22	Watchdog Timer	Z	External Test Reset
23	+24VDC	AA	+24VDC
24	Tied to Pin 25	BB	Stop Time (Output)
25	Tied to Pin 24	CC	Not Assigned
26	Not Assigned	DD	Not Assigned
27	Relay Output, Side #3, N.O.	EE	Relay Output, Side #2, Common
28	Relay Output, Side #1, N.C.	FF	AC+

-- Slotted for keying between Pins 17/U and 18/V

CONFLICT PROGRAM CARD PIN ASSIGNMENTS

Pin #	Function (Back Side)	Pin #	Function (Component Side)
1	Channel 2 Green	A	Channel 1 Green
2	Channel 3 Green	B	Channel 2 Green
3	Channel 4 Green	C	Channel 3 Green
4	Channel 5 Green	D	Channel 4 Green
5	Channel 6 Green	E	Channel 5 Green
6	Channel 7 Green	F	Channel 6 Green
7	Channel 8 Green	H	Channel 7 Green
8	Channel 9 Green	J	Channel 8 Green
9	Channel 10 Green	K	Channel 9 Green
10	Channel 11 Green	L	Channel 10 Green
11	Channel 12 Green	M	Channel 11 Green
12	Channel 13 Green	N	Channel 12 Green
13	Channel 14 Green	P	Channel 13 Green
14	Channel 15 Green	R	Channel 14 Green
15	Channel 16 Green	S	Channel 15 Green
16	N/C	T	PC AJAR
17	Channel 1 Yellow	U	Channel 9 Yellow
18	Channel 2 Yellow	V	Channel 10 Yellow
19	Channel 3 Yellow	W	Channel 11 Yellow
20	Channel 4 Yellow	X	Channel 12 Yellow
21	Channel 5 Yellow	Y	Channel 13 Yellow
22	Channel 6 Yellow	Z	Channel 14 Yellow
23	Channel 7 Yellow	AA	Channel 15 Yellow
24	Channel 8 Yellow	BB	Channel 16 Yellow
--		--	
25	Channel 17 Green	CC	Channel 17 Yellow
26	Channel 18 Green	DD	Channel 18 Yellow
27	Channel 16 Green	EE	PC AJAR (Program Card)
28	Yellow Inhibit Common	FF	Channel 17 Green

-- Slotted for keying between Pins 24/BB and 25/CC

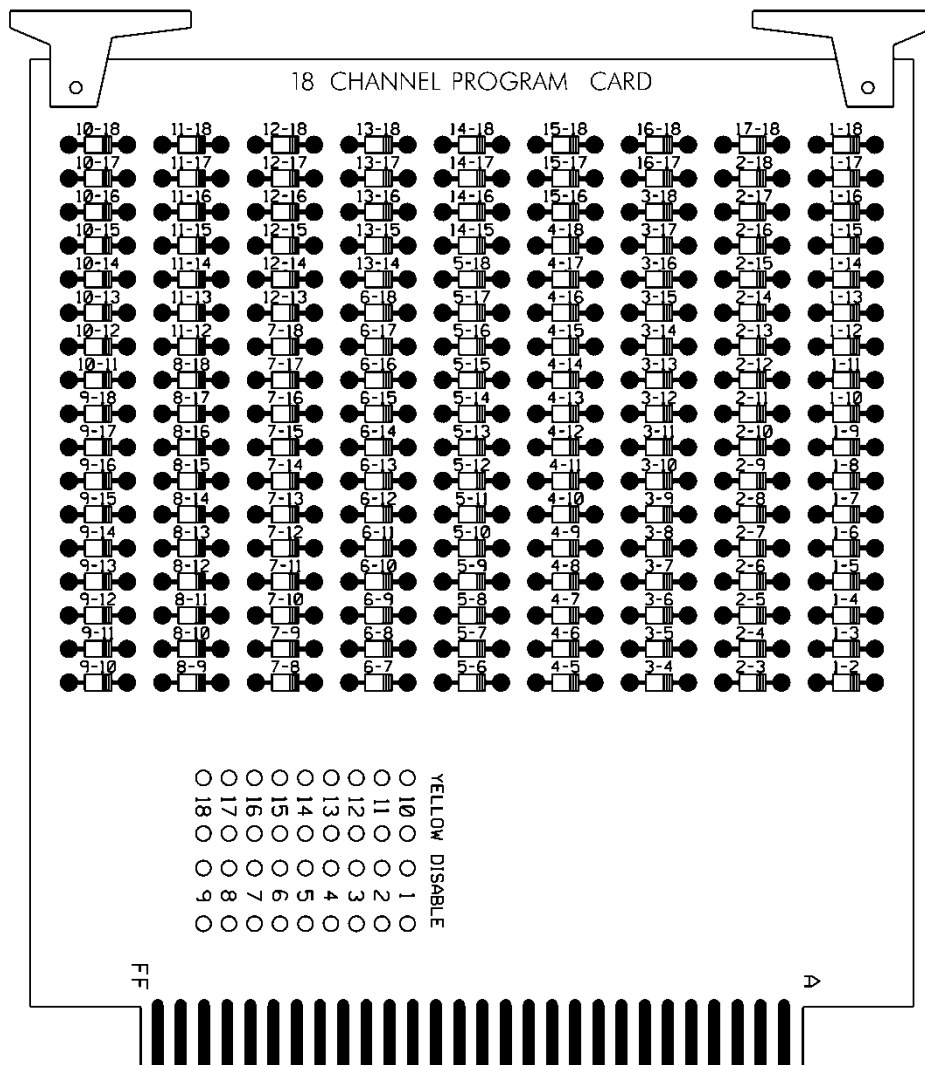

E. Preemption and Sign Control Box

Provide preemption and sign control box to operate in a Model 332 and Model 336S cabinet. Provide hardware to mount the box to the cage of the cabinet to ensure the front side is facing the opposite side of the cabinet. Furnish the material of the box from a durable finished metallic or thermoplastic case. Ensure the size of the box is not greater than 7(l) x 5(w) x 5(d) inches. Ensure that no modification is necessary to mount the box on the cabinet cage.

Provide the following components in the preemption and sign control box: relays, fuses, terminal blocks, MOVs, resistor, RC network, lamp, and push button switch.

Provide UL Listed or Recognized relay K1 as a DPDT enclosed relay (120 VAC, 60 Hz coil) with an 8-pin octal-style plug and associated octal base. Provide contact material made of AgCdO with a 10 amp, 240 VAC rating. Ensure the relay has a specified pickup voltage of 102 VAC.

Provide relay SSR1 as a Triac SPST normally open solid state relay that is rated for 120 VAC input and zero-crossing (resistive load) 25 amp @ 120 VAC output. Ensure the relay turns on at 90 Vrms within 10 ms and turns off at 10 Vrms within 40 ms. Ensure the relay has physical

characteristics as shown in the wiring detail in Figure 1. Provide 4 terminal screws with saddle clamps.

Provide fuses F1 and F2 as a UL Listed ¼" x 1-1/4" glass tube rated at 250 volts with a 10kA interrupting rating. Ensure F1 non-delay (fast-acting) and F2 slow-blow (time-delay) fuses have a maximum opening times of 60 minutes and 120 seconds for currents of 135 and 200 percent of the ampere rating, respectively. Ensure F2 slow-blow (time-delay) fuses have a minimum opening times of 12 seconds at 200 percent of the ampere rating. Provide fuse holders that are UL Recognized panel-mounted holders rated 250V, 15 ampere minimum with bayonet-type knobs which accept ¼" x 1-1/4" glass tube fuses.

Provide terminal blocks that are rated for 300V and are made of electrical grade thermoplastic or thermosetting plastic. Ensure each terminal block is of closed back design and has recessed-screw terminals with molded barriers between terminals. Ensure each terminal block is labeled with a block designation. Ensure each terminal is labeled with the function and a number.

Provide 3/4-inch diameter radial lead UL-recognized metal oxide varistors (MOVs) that have electrical performance as outlined below.

PROPERTIES OF MOV SURGE PROTECTOR	
Maximum Continuous Applied Voltage at 185° F	150 VAC (RMS) 200 VDC
Maximum Peak 8x20µs Current at 185° F	6500 A
Maximum Energy Rating at 185° F	80 J
Voltage Range 1 mA DC Test at 77° F	212-268 V
Max. Clamping Voltage 8x20µs, 100A at 77° F	395 V
Typical Capacitance (1 MHz) at 77° F	1600 pF

Provide resistor R1 as a 2K ohm, 12 watt, wirewound resistor with tinned terminals and attaching leads. Ensure the resistor is spaced apart from surrounding wires.

Provide a LED or incandescent lamp that has a voltage rating of 120 VAC with a minimum life rating at 50,000 hours.

Wire the preemption and sign control box as shown in Figure 1.

RAILROAD PREEMPTION WIRING DETAIL

(wire as shown below)

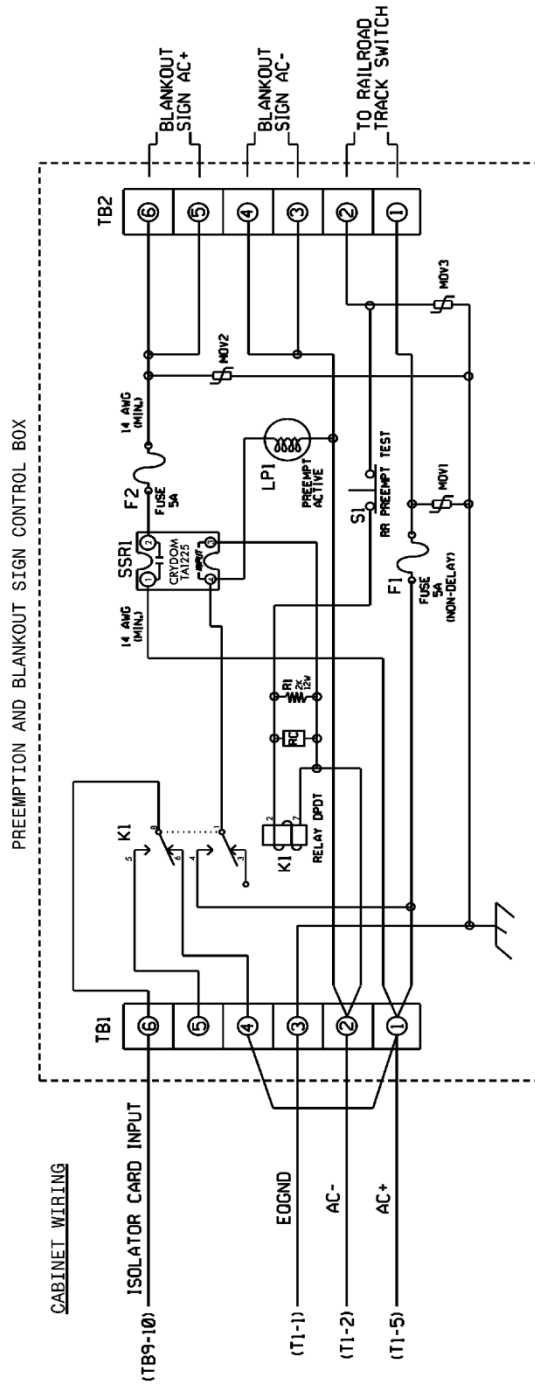

NOTES

1. RELAY K1 IS SHOWN IN THE ENERGIZED (PREEMPT NO1 ACTIVE) NORMAL OPERATION STATE.
2. AC ISOLATOR CARD SHALL ACTIVATE PREEMPTION UPON REMOVAL OF AC+ FROM INPUT (AS SHOWN ABOVE). THIS IS ACCOMPLISHED BY SETTING TYPE 252 AC ISOLATOR CARD TO INVERTED OPERATION.

FRONT VIEW

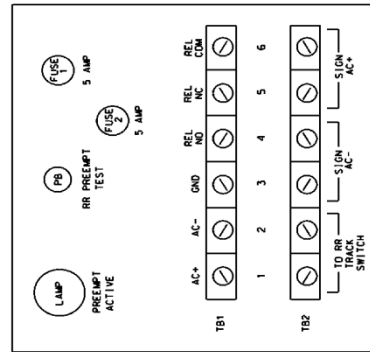

Figure 1

4.10. MATERIALS – ADVANCED TRANSPORTATION CONTROLLER CABINET (ATCC)**A. ATC Cabinet Components:****1. Model 2202-HV High-Density Switch Pack / Flasher Unit (HDSP/FU)**

Provide the HDSP/FU that is compact, pluggable, modular PCB-based, and equipped with DIN connector. Ensure the HDSP/FU is compatible with ultra-low power LED signal heads and has a current monitoring feature for each output of each channel. Ensure the HDSP/FU uses real-time standardized high speed SB3 communications with the Cabinet Monitor Unit to send a complete set of RMS voltage and load current measurements. Ensure the HDSP/FU is 4.5” H x 6.5” D and is equipped with a handle, reset push button switch, six RYG LED indicators, four flasher LED indicators, one power LED indicator and two Rx/Tx LED indicators. Ensure the HDSP/FU can function as either a switch pack (HDSP) or as a flasher unit (HDFU). Ensure the High-Density Switch Pack (HDSP) provides two RYG channels of operation (6 outputs) when installed in the Output Assembly. Ensure the High-Density Flasher Unit (HDFU) shall function as a four-output flasher when installed in the Service Assembly or Power Assembly.

2. Model 2212-HV Cabinet Monitor Unit (CMUip)

Provide the Cabinet Monitor Unit (CMUip) that is compact, pluggable and modular. Ensure the CMUip uses real-time standardized 614.4 Kbps SDLC communications with the ATC to transfer command and response data on Serial Bus #1 (SB1). Furnish a CMUip that will monitor up to 32 physical switch pack channels (RYG) and has optional four virtual channels. Ensure the CMUip provides a Flasher Alarm feature. Ensure the CMUip analyzes the ATC output commands and field input status to isolate the failure source by channel and color. Ensure the CMUip configuration programming is provided by an interchangeable Data key nonvolatile memory device. Ensure a rugged Data key that stores all CMUip configuration parameters and eliminate programming using jumpers, diodes, or DIP switches. Ensure the CMUip maintains a nonvolatile event log recording the complete intersection status as well as time stamped previous fault events, AC Line events, configuration changes, monitor resets, cabinet temperature and true RMS voltages and currents for all field inputs. Ensure the signal sequence history log stored in nonvolatile memory graphically display up to 30 seconds of signal status prior to the fault trigger event with 50 ms resolution to ease diagnosing of intermittent and transient faults.

3. Model 2218 Serial Interface Unit (SIU)

Provide the Model 2218 Serial Interface Unit (SIU) that is compact, pluggable and modular. Ensure the SIU uses real-time standardized 614.4 Kbps SDLC communications with the ATC to transfer command and response data on Serial Bus #1 (SB1). Ensure the SIU is equipped with 54 programmable input/output pins, 4 optically isolated input pins, 1 line sync reference input pin and 4 address select input pins. Furnish the optically isolated inputs to work with either 12 Vac or 24 Vdc. Ensure the SIU outputs are rated at 150 mA continuous sink current. Ensure each output provides a 500-mA typical current limit and is rated to 50 V and utilizes a voltage clamp for inductive transient protection. Equip the SIU with a front panel LED indicator that can report the current SIU assembly address assignment of the SIU for cabinet configuration verification.

4. Model 2220 Auxiliary Display Unit (ADU)

Furnish the ADU for installation in a 1U height 19" rack space. Ensure the ADU provides a menu driven user interface to enhance the features of the CMU monitor including the built-in Diagnostic Wizard. Ensure the ADU provides 32 channels of Red, Yellow and Green LED indicators that display full intersection status and 32 Blue fault status LED indicators to identify faulty channels. Ensure the ADU provides proper electrical termination to SB3. Furnish the ADU with a 4 line by 20-character menu driven liquid crystal display that has a backlight and heater. Ensure the ADU built-in Diagnostic Wizard shall automatically pinpoint faulty signals and offers troubleshooting guidance and automatically isolate and identify problems. Ensure the ADU is equipped with Event Logging displaying the CMU time-stamped nonvolatile event log records with the complete intersection status as well as AC Line events, monitor resets, temperature and true RMS voltages and currents.

5. Model 2216-24-HV Cabinet Power Supply (CPS)

Provide the CPS to install in a 1U height 19" rack space. Ensure the CPS is rated at 168 Watts, 48 Vdc @ 1 Amp and 24 Vdc @ 5 Amp. Ensure the CPS has power factor corrected features and a full load power factor of 0.98 or better, reducing peak AC Line input current and associated stress on wiring. Provide the CPS using modern switching technology and full output regulation across changes in AC Line voltage and output load over the full operating temperature range of -34C to +74C without the need for a fan. Ensure the CPS has separate green LED indicators that display AC input status, DC output status and associated fuse integrity. Ensure the CPS outputs are fused for over-current protection and protected against voltage transients by a 1500-Watt suppressor.

6. Model 21H High-Density Flash Transfer Relay (HDFTR)

Provide the HDFTR to have a hermetically sealed cover and that is moisture proof. Ensure the HDFTR is filled with dry nitrogen to protect contacts from corrosion and to prevent condensation. Furnish the HDFTR to have a shock/impact resistant metal can cover with solid and bend proof pins. Ensure the HDFTR contacts are rated at 120 Vac @ 10 Amp and coil is rated at 48 Vdc. Ensure the HDFTR has an LED indicator to display contact transfer position.

7. Main Contactor (MC)

Provide the MC that is mercury free and rated at 120 Vac @ 60 Amp. Ensure the coil of the MC is rated at 48 Vdc. Ensure the MC is equipped with input indicator and has SPST- N.O. contacts.

8. Cabinet Suppressor-Filter

Provide the cabinet that is equipped with a Cabinet Suppressor-Filter. Ensure Suppressor is secured prior to shipping to prevent damage during shipping. Ensure the unit incorporates the use of warning and failure indicators. Ensure the unit is modular and pluggable with a 12-position Beau 5412 connector. Ensure the device meets the following specifications:

Peak Surge Current (Single pulse, 8x20µs) 20,000A

Occurrences (8x20µs waveform)10 minimum @ 20,000A

Maximum Clamp Voltage.....395VAC

Operating Current.....15 amps
 Response Time..... < 5 nanoseconds

9. HDSP Suppressor

Provide the HDSP Suppressor that is modular and pluggable. Ensure the unit is epoxy encapsulated and equipped with 9-position 5.08 mm Phoenix Contact connector or approved equal. Ensure the unit is able to protect 6 circuits. Ensure the device meets the following specifications:

Peak Surge Current (Single pulse, 8x20µs)20,000A
 Maximum Clamp Voltage.....350VAC
 Response Time..... < 200 nanoseconds
 Discharge Voltage.....<200 Volts @ 1,000A
 Insulation Resistance.....≥100 MΩ

The unit dimensions shall be 2" H x 0.7" W x 2" D.

10. Detection Module Suppressor

Provide the Detection Module Suppressor that is modular and pluggable. Ensure the unit is epoxy encapsulated and equipped with 6-position 5.08 mm Phoenix Contact or approved equal connector. Ensure the device meets the following specifications:

Peak Surge Current (6 times, 8x20µs)
 (Differential Mode)400A
 (Common Mode)1,000A
 Occurrences (8x20µs waveform)500 min @ 200A
 Maximum Clamp Voltage
 (Differential Mode @400A)35V
 (Common Mode @1,000A)35V
 Response Time..... < 5 nanoseconds
 Maximum Capacitance.....35 pF

B. ATC Cabinet General Requirements

Provide the ATC Cabinet that conforms to the ATC 5301 Standard Publication No. v2.02, except as required herein.

Furnish assemblies that are rack mountable and completely removable from or installable in the ATC Cabinet cage without removing any other equipment and using only standard slotted or Phillips screwdriver.

Ensure the cabinet provides Cabinet Flash signal operation in the absence of any of the following assemblies: Input Assembly, Output Assembly, and Controller.

Provide a momentary push button that, when pressed, energizes the 24 Vdc to the HDSPs during Flash Mode. Ensure the button is labeled “24 VDC BYPASS” and located on the front of the Output Assembly.

Ensure high-voltage components (over 50 V) are protected from incidental contact per NEC.

Ensure the Service Assembly is modular and mounted on the left of the front or rear EIA rail when viewed from the front. The Service Assembly shall house at the minimum, the Main circuit breaker, a GFCI protected duplex outlet protected by a 15A circuit breaker, Cabinet Suppressor–Filter, one convenience outlet NEMA 5-15 format, four HDFU output fuses and five Circuit Breakers. Optionally, you may locate the four HDFU fuses and five Circuit Breakers in another approved location.

Provide two main power entry terminal blocks, one for service power and one for a backup power source. Provide a relay to switch from service power to backup power when a backup power source is applied to the backup power terminal block. Ensure the relay switches back to service power only when the backup power source is manually removed. Ensure the terminal blocks are protected with a clear polycarbonate cover.

Ensure all circuit breakers located on the rack have covers to prevent accidental tripping.

Ensure all fuses, circuit breakers, switches (except police panel switches) and indicators are readily visible and accessible when the ATC Cabinet front and back doors are open.

Ensure all Assemblies are modular with pluggable cabling. Provide clean wiring of the cabling. Hardwiring of the assemblies is not permissible.

Integrate wiring guides, raceways and tie downs as part of the ATC Cabinet allowing for neat internal and field wiring. Ensure wires and cables do not block, hinder or inhibit the installation of standard rack mounted equipment for the full height and width of the rack chassis.

Provide marker strips that are made of material that can be easily and legibly written on using a pencil or ballpoint pen. Ensure marker strips are located immediately below the item they are to identify and must be clearly visible with the items installed.

Provide guides (top and bottom) for the assembly plug-in units. Ensure the guides begin at 0.50 inch from the assembly front panel face.

Ensure each electric fan is equipped with ball or roller bearings and has a minimum capacity of 100 cubic feet of free air delivery per minute. Provide two DC or AC powered fans that are mounted within the housing and protected with a finger guard. Provide a Fan Test switch. Ensure the ventilation fans are fastened to the cabinet via one or two thumb screws and not fastened in a manner that requires any tools for removal or installation.

Ensure the housing is rainproof. Ensure the housing has front and rear doors that are both equipped with a lock and handle. Ensure the enclosure top is crowned to prevent standing water.

Ensure the enclosure, doors, lifting eyes, gasket channels, police panel door, spacer supports, and all supports welded to the enclosure and doors are fabricated of 0.125-inch minimum thickness aluminum sheet. Ensure the filter shell, filter trough, fan support and police panel enclosure are fabricated of 0.080-inch minimum thickness aluminum sheet. Provide the spacer supports with the option to use 0.059-inch minimum stainless-steel sheet.

Ensure all exterior seams for enclosure and doors are continuously welded and smooth. Ensure all edges are filled to a radius of 0.03125 inch minimum. Ensure the exterior cabinet welds are done by gas Tungsten arc TIG process only. Ensure ER5356 aluminum alloy bare welding electrodes conforming to AWS A5.10 requirements are used for welding on aluminum. Ensure procedures, welders and welding operators conform to the requirements and practices in AWS B3.0 and C5.6 for aluminum. Provide internal cabinet welds that are done by gas metal arc MIG or gas Tungsten arc TIG process.

Furnish unpainted, natural, aluminum cabinet shells. Ensure that all non-aluminum hardware on the cabinet is stainless steel or a Department approved non-corrosive alternate.

Ensure the enclosure door frames are double flanged out on all four sides and have strikers to hold tension on, and to form a firm seal between, the door gasketing and the frame. Ensure the dimension between the door edge and the enclosure external surface when the door is closed and locked is 0.156 inch (+/-0.08 inches).

Ensure gasketing is provided on all door openings and dust tight. Ensure gaskets are 0.25 inches minimum thickness closed cell neoprene or silicone (BOYD R- 108480 or approved equal) and permanently bonded to the metal. Provide a gasket top and side channels to support the top gasket on the door to prevent gasket gravitational fatigue.

Provide the housing with 2 lifting eyes for placing the cabinet on its foundation. Ensure each eye opening has a minimum diameter of 0.75 inch. Ensure each eye is able to support the weight load of 1000 lbs. Ensure all bolt heads are tamperproof type.

Provide front and rear doors with latching handles that allow padlocking in the closed position. Furnish 0.75-inch minimum diameter stainless steel handles with a minimum 0.5 inch shank. Place the padlocking attachment at 4.0 inches from the handle shank center to clear the lock and key. Provide an additional 4.0 inches minimum gripping length.

Ensure the latching mechanism is a three-point draw roller type. Ensure the pushrods are turned edgewise at the outward supports and have a cross section of 0.25 inch thick by 0.75 inch wide, minimum.

Provide Corbin #2 locks on the front and rear doors. Provide one (1) Corbin #2 and one (1) police master key with each cabinet. Ensure main door locks allow removal of keys in the locked position only.

Ensure the door is locked when the door is closed and latched. Provide locks and handles on the right side of the front door and left side of the rear door. Ensure the lock and lock support are rigidly mounted on the door. In the locked position, ensure the bolt throw extends a minimum of 0.25 ± 0.03125 inch into the latch Cam area. Provide a seal to prevent dust or water entry through the lock opening.

Ensure the locks have rectangular, spring-loaded bolts. Ensure the bolts have a 0.281 inch throw and are 0.75 inch wide by 0.75 inch thick (tolerance is ± 0.035 inch).

Fabricate the center latch cam with a minimum thickness 0.1875 inch steel or aluminum. Ensure the bolt surface horizontally covers the cam thickness. Ensure the cam is structured to only allow the door to open when the handle is moved toward the center of the door.

Provide rollers that have a minimum diameter of 0.875 inch with nylon wheels and steel ball bearings.

Provide stainless steel hinges (two bolts per leaf) to bolt the enclosure to the doors.

For each door, furnish four hinges per door for a 352 cabinet and three hinges per door for a 356 cabinet. Ensure each hinge is 3.5-inch minimum length and have a fixed pin. Ensure the pin ends are welded to hinge and ground smooth. Ensure the pins and bolts are covered by the door edge and not accessible when the door is closed. Provide a ground strap between the door and the main cabinet housing when 120 Vac devices are mounted on the door.

Provide front and rear doors with catches to hold the door open at both 90 and 165 (+/-10) Degrees. Ensure the catch minimum diameter is 0.375-inch aluminum rods. Ensure the catches hold the door open at 90 degrees in a 60-mph wind acting at an angle perpendicular to the plane of the door.

Provide a police panel assembly that allows limited control access. Equip the panel door with a lock and master police key. Ensure the front and back of the panel is enclosed with a rigid metal covering so that no parts having live voltage are exposed. Ensure the panel assembly has a drain to prevent water from collecting within the assembly. Ensure the drain is channeled to the outside. Ensure the cabinet has one switch provided and labeled "SIGNALS ON / OFF" and one switch provided and labeled "FLASH / AUTO". Provide the MANUAL CONTROL ENABLE ON / OFF switch and a 1/4-inch locking phone jack for the INTERVAL ADVANCE cord. Provide an INTERVAL ADVANCE cord that is six feet in length. Ensure that manual control can be implemented using inputs and software such that the controller provides full programmed clearance times for the yellow clearance and red clearance for each phase while under manual control.

Install a standard rack cage inside the housing for mounting of the ATC and cabinet assemblies. Ensure the EIA rack portion of the cage consists of four continuous, adjustable equipment mounting angles. Ensure the mounting angle nominal thickness is 11- gauge plated steel. Ensure the mounting angles are tapped with 10-32 threads with EIA universal spacing. Ensure the mounting angle complies with standard EIA-310-B and is supported at the top and bottom by either welded or bolted support angles to form a cage. Provide the mounting angles with holes to mount the side panels.

Ensure the cage is bolted to the cabinet at four points via the housing cage supports and four points via associated spacer brackets (top and bottom).

Ensure the cage is centered within the cabinet door opening(s).

Provide cage mounting supports on either side, level with the bottom edge of the door opening, for horizontal support and bolt attachment; side cage supports provided for the bracket cage supports; and bracket cage support attachments.

Provide a minimum 12.5 x 16 inch pull out, hinged top shelf located immediately below controller mounting section of the cabinet. Ensure the shelf is designed to fully expose the table surface outside the controller at a height approximately even with the bottom of the controller. Ensure the shelf has a storage bin interior which is a minimum of 1 inch deep and approximately the same dimensions as the shelf. Provide an access to the storage area by lifting the hinged top of the shelf. Fabricate the shelf and slide from aluminum or stainless steel and ensure the assembly can support the 2070LX controller plus 15 pounds of additional weight. Ensure shelf has a locking mechanism to secure it in the fully extended position and does not inhibit the removal of the 2070LX controller or removal of cards inside the controller when fully extended. Provide a locking mechanism that is easily released when the shelf is to be returned to its non-use position directly under the controller.

Ensure housing ventilation includes intake, exhaust, filtration, fans and thermostat.

Provide the louvered vent depth of a maximum of 0.25 inch. Ensure a removable and reusable air filter is housed behind the door vents. Ensure the filter filtration covers the vent opening area. Provide a filter shell that fits over the filter providing mechanical support for the filter. Ensure the shell is louvered to direct the incoming air downward. Ensure the shell sides and top are bent over a minimum of 0.25 inch to house the filter. Ensure the filter resident in its shell is held firmly in place with a bottom trough and spring-loaded upper clamp. Ensure no incoming air bypasses the filter. Form the bottom filter into a waterproof sump with drain holes to the outside housing. Ensure the filter is 16-inch-wide by 12-inch-high by 0.875 inch thick. Ensure the filter is an ECO-AIR Product E35S or approved equal.

Provide thermostatically controlled fans that are manually adjustable to turn on at 80°F with a differential of not more than 20°F between automatic turn on and off. Ensure the fan circuit is protected at 125% of the fan motor capacity. Ensure the manual adjustment is graded in 20 Fahrenheit increment scale. Ensure the Thermostat is an Omega KT01101141900 or approved equal.

Equip the cabinet with two LED lights activated by door switches and with a minimum of one fuse.

Furnish two sets of non-fading cabinet wiring diagrams and schematics in a paper envelope or container and placed in the cabinet drawer.

Provide detector test switches for all channel detector inputs mounted at the top of the cabinet rack which may be used to place a call to each input in the Input Assembly. Provide three positions for each switch: On (place call), Off (normal detector operation), and Momentary On (place momentary call and return to normal detector operation after switch is released). Ensure that the switches are located such that the technician can read the controller display and observe the intersection. Ensure all detector test switches are labeled with the channel number (ex: CH1...CH48) above each switch and have a marker strip immediately below the switch.

Provide AC- bus bar and Equipment Ground bus bar on the J-service panel with each having a minimum of 16 terminals. Ensure the AC- copper terminal bus is not grounded to the cabinet or connected to logic ground. Provide nylon screws with a minimum diameter of 1/4 inch for securing the bus to the service panel.

Ensure the SB1/SB2 and DC/Clean Power Bus include eight connectors to interconnect the SB1/SB2 communication ports of the assemblies and Controller. You may also daisy-chain the SB1/SB2 Bus through each assembly. Ensure the SB1/SB2 includes a termination circuit at the end of the connections to prevent radio frequency signal reflection. It shall include one Phoenix Contact plug block or approved equivalent to bring the DC power to the Bus; ensure such power is distributed to the ATC Cabinet Assemblies through seven Phoenix Contact receptacle blocks or approved equal. The AC Clean Power Bus shall also include a minimum of 5 NEMA 5-15 receptacles to provide AC Clean Power to the ATC Cabinet Assemblies, the Controller and Cabinet Power Supply.

Ensure the SB1/SB2 and DC/Clean Power Bus is mounted across the EIA rails and swings down or out to provide access to the back of the assemblies mounted in the opposite side.

Provide Model 242 DC isolators and Model 252 AC isolators that conform to CALTRANS' "Transportation Electrical Equipment Specifications" dated March 12, 2009 with Erratum 2 as required by plans.

Ensure flash circuits are wired as follows:

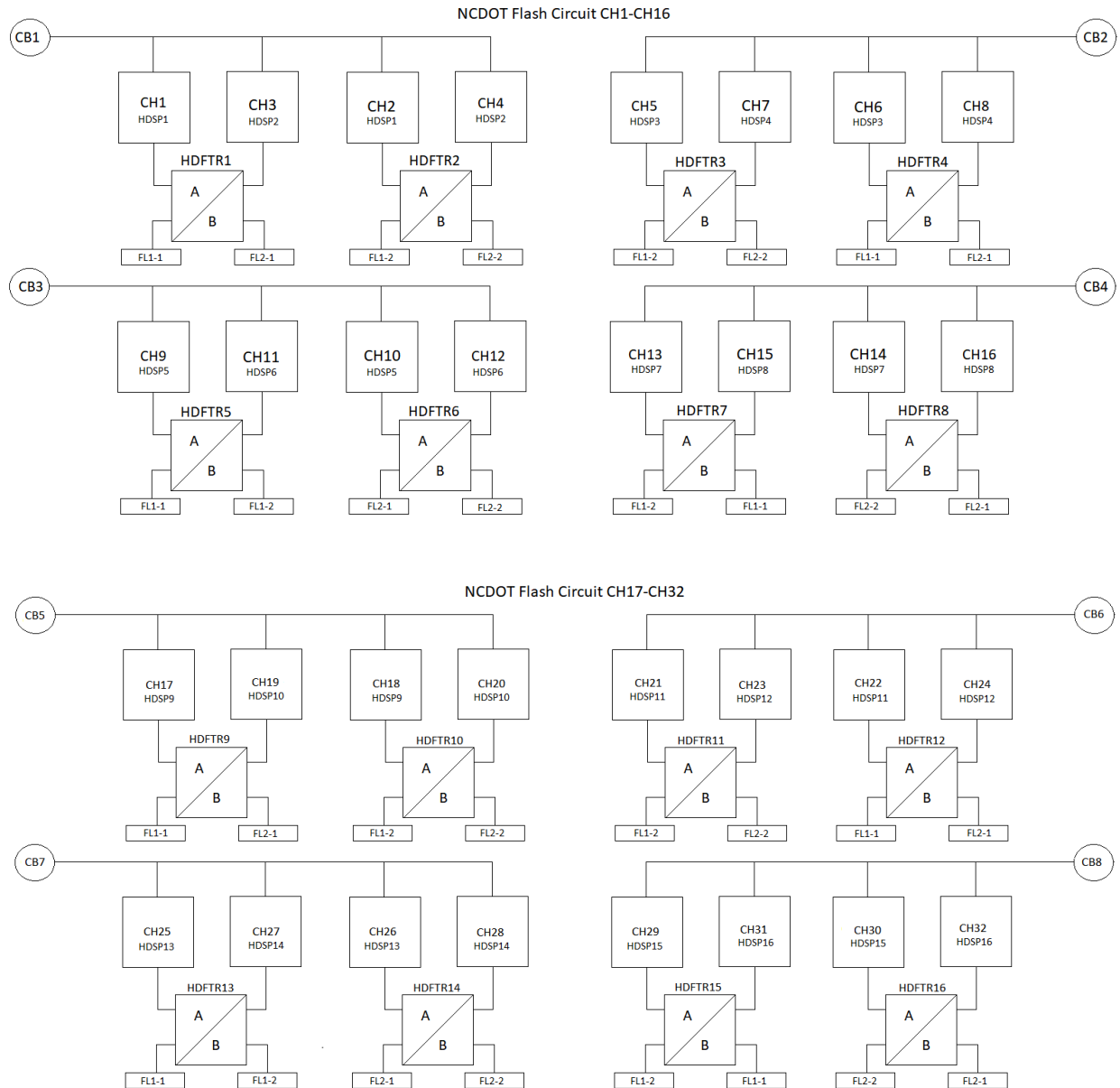

C. Model 352i ATC Cabinet with 16-Channel Output and 24-Channel Input

Furnish a 120 Vac High Voltage (HV) Model 352i base mounted Advanced Transportation Controller (ATC) cabinet configured for 16 Channel Output and 24 Input Channels. The cabinet shall include: Service Assembly (SA), Input Assembly (IA), Output Assembly (OA), SB1/SB2 Bus, AC/DC Bus, Clean Power Outlets and DC/Clean Power Bus, Field Input Termination Assembly (FITA), and Field Output Termination Assembly (FOTA). Ensure the cabinet is: 67” H x 24” W x 30” D.

The Model 352i ATC Cabinet with 16-Channel Output and 24-Channel Input shall consist of following Assemblies and Components.

(9 each) Model 2202-HV (HDSP-FU) or approved equal

- (2 each) Model 2218 SIU or approved equal
- (1 each) Model 2212-HV CMUip or approved equal
- (8 each) Model 21H HDFTR or approved equal
- (1 each) Model 2220 ADU or approved equal
- (1 each) Model 2216-24 CPS or approved equal
- (16 each) Red Flash Program Block
- (4 each) Yellow Flash Program Block
- (4 each) White Flash Program Block
- (1 each) Cabinet Suppressor–Filter
- (12 each) Loop Detection Suppressor
- (8 each) HDSP Suppressor

Modules / Assemblies	Quantity
352i Housing / 352i Cage / 352i Side Panels	1
Service Assembly	1
Output Assembly (16 - Channel)	1
Field Output Termination Assembly (16 - Channel)	1
Input Assembly (24 - Channel)	1
Field Input Termination Assembly (24 - Channel)	1
SB1/SB2 and DC/Clean Power Bus	1
Model 2216-24 Cabinet Power Supply	1
CMU Auxiliary Display Unit	1
LED - Cabinet Light Assembly	2
Drawer Shelf Unit	1

D. Model 352i ATC Cabinet with 16-Channel Output and 48-Channel Input

Furnish a 120 Vac High Voltage (HV) Model 352i base mounted Advanced Transportation Controller (ATC) cabinet configured for 16 Channel Output and 48 Input Channels. The cabinet shall include: Service Assembly (SA), Input Assembly (IA), Output Assembly (OA), SB1/SB2 Bus, AC/DC Bus, Clean Power Outlets and DC/Clean Power Bus, Field Input Termination Assembly (FITA), and Field Output Termination Assembly (FOTA). Ensure the cabinet is: 67” H x 24” W x 30” D.

The Model 352i ATC Cabinet with 16-Channel Output and 48-Channel Input shall consist of following Assemblies and Components.

- (9 each) Model 2202-HV (HDSP-FU) or approved equal
- (3 each) Model 2218 SIU or approved equal
- (1 each) Model 2212-HV CMUip or approved equal
- (8 each) Model 21H HDFTR or approved equal
- (1 each) Model 2220 ADU or approved equal
- (1 each) Model 2216-24 CPS or approved equal
- (16 each) Red Flash Program Block
- (4 each) Yellow Flash Program Block
- (4 each) White Flash Program Block
- (1 each) Cabinet Suppressor–Filter
- (24 each) Loop Detection Suppressor
- (8 each) HDSP Suppressor

Modules / Assemblies	Quantity
352i Housing / 352i Cage / 352i Side Panels	1
Service Assembly	1
Output Assembly (16 - Channel)	1
Field Output Termination Assembly (16 - Channel)	1
Input Assembly (24 - Channel)	2
Field Input Termination Assembly (24 - Channel)	2
SB1/SB2 and DC/Clean Power Bus	1
Model 2216-24 Cabinet Power Supply	1
CMU Auxiliary Display Unit	1
LED - Cabinet Light Assembly	2
Drawer Shelf Unit	1

E. Model 352i ATC Cabinet with 32-Channel Output and 48-Channel Input

Furnish a 120 Vac High Voltage (HV) Model 352i base mounted Advanced Transportation Controller (ATC) cabinet configured for 32 Channel Output and 48 Input Channels. The cabinet shall include: Service Assembly (SA), Input Assembly (IA), Output Assembly (OA), SB1/SB2 Bus,

AC/DC Bus, Clean Power Outlets and DC/Clean Power Bus, Field Input Termination Assembly (FITA), and Field Output Termination Assembly (FOTA). Ensure the cabinet is: 67” H x 24” W x 30” D.

The Model 352i ATC Cabinet with 32-Channel Output and 48-Channel Input shall consist of following Assemblies and Components.

- (18 each) Model 2202-HV (HDSP-FU) or approved equal
- (4 each) Model 2218 SIU or approved equal
- (1 each) Model 2212-HV CMUip or approved equal
- (16 each) Model 21H HDFTR or approved equal
- (1 each) Model 2220 ADU or approved equal
- (1 each) Model 2216-24 CPS or approved equal
- (32 each) Red Flash Program Block
- (8 each) Yellow Flash Program Block
- (8 each) White Flash Program Block
- (1 each) Cabinet Suppressor–Filter
- (24 each) Loop Detection Suppressor
- (16 each) HDSP Suppressor

Modules / Assemblies	Quantity
352i Housing / 352i Cage / 352i Side Panels	1
Service Assembly	1
Output Assembly (32 - Channel)	1
Field Output Termination Assembly (32 - Channel)	1
Input Assembly (24 - Channel)	2
Field Input Termination Assembly (24 - Channel)	2
SB1/SB2 and DC/Clean Power Bus	1
Model 2216-24 Cabinet Power Supply	1
CMU Auxiliary Display Unit	1
LED - Cabinet Light Assembly	2
Drawer Shelf Unit	1

F. Model 356i ATC Cabinet

Furnish a 120 Vac High Voltage (HV) Model 356i pole mounted Advanced Transportation Controller (ATC) cabinet configured for 16 Channel Output and 24 Input channels. The cabinet shall include: Service Assembly (SA), Input Assembly (IA), Output Assembly (OA), SB1/SB2 Bus, AC/DC Bus, Clean Power Outlets and DC/Clean Power Bus, Field Input Termination Assembly (FITA), and Field Output Termination Assembly (FOTA). Ensure the cabinet is: 46” H x 24” W x 20” D.

The Model 356i ATC Cabinet shall consist of following Assemblies and Components.

- (9 each) Model 2202-HV (HDSP-FU) or approved equal
- (2 each) Model 2218 SIU or approved equal
- (1 each) Model 2212-HV CMUip or approved equal
- (8 each) Model 21H HDFTR or approved equal
- (1 each) Model 2220 ADU or approved equal
- (1 each) Model 2216-24 CPS or approved equal
- (16 each) Red Flash Program Block
- (4 each) Yellow Flash Program Block
- (4 each) White Flash Program Block
- (1 each) Cabinet Suppressor–Filter
- (12 each) Loop Detection Suppressor
- (8 each) HDSP Suppressor

Modules / Assemblies	Quantity
356i Housing / 356i Cage / 356i Side Panels	1
Service Assembly	1
Output Assembly (16 - Channel)	1
Field Output Termination Assembly (16 - Channel)	1
Input Assembly (24 - Channel)	1
Field Input Termination Assembly (24 - Channel)	1
SB1/SB2 and DC/Clean Power Bus	1
Model 2216-24 Cabinet Power Supply	1
CMU Auxiliary Display Unit	1
LED - Cabinet Light Assembly	2

Drawer Shelf Unit	1
-------------------	---

G. Cabinet Assemblies

1. 16-Channel Output Assembly

Provide the Output Assembly that is 3U high rack mounted assembly. The Output Assembly shall accommodate eight Model 2202-HV High-Density Switch Pack / Flasher Units (HDSP/FU), providing 48 output circuits. Ensure the Output Assembly accommodates one Model 2218 Serial Interface Unit (SIU) to provide interface and control via system SB1/SB2. Ensure the Output Assembly accommodates one Model 2212-HV Cabinet Monitor Unit (CMUip), Main Contactor, Stop Time Switch, Flash / Auto Switch, four Circuit Breakers and Momentary 24 Vdc Bypass Switch.

2. 16-Channel Field Output Termination Assembly

Ensure the Field Output Termination Assembly is coupled with the 16-Channel Output Assembly and shall house eight Model 21H High-Density Flash Transfer Relays (HDFTR). Provide the HDFTRs and Flash Program Blocks (FPB) to control and select the color (red, yellow, or dark) during ATC Cabinet flash mode. Provide the HDSP Suppressors at the field terminals for the protection of the HDSP. Ensure each HDFTR position is labeled with the number of its associated HDSP (1-16) and each FPB position is labeled with the number of its associated channel (1-16).

Provide the Field Output Termination Assembly with touch-safe Phoenix Contact terminal blocks (or approved equal) in accordance with the ATC Standard ATC 5301 v02.02. Ensure each Load Terminal Block receptacle is labeled with the number of its associated channel (1-16). Provide labels or silkscreens to clearly indicate which terminals correspond to the red, yellow, and green switch pack outputs. The color of these labels shall match the color of their associated output (red, yellow, or green).

Provide one 16-channel Field Output Termination Assembly with each 16-channel Output Assembly.

Mount the 16-Channel Field Output Termination Assembly across the rear cabinet EIA rails and ensure it swings down to provide access to the HDSP Suppressors.

3. 24-Channel Input Assembly

Ensure the Input Assembly is a 3U high rack mounted assembly providing twelve slots of 22/44 pin PCB sockets. Ensure one Model 2218 Serial Interface Unit (SIU) is provided and mated to a DIN 96-pin connector. Ensure the SIU provides interface and control between the Controller and the detection modules via system SB1/SB2. The Input Assembly shall house 2-channel detection modules only, up to 12 detection modules providing a maximum of 24 channels. Equip the Input Assembly with an Opto Input Card. Ensure the Opto Input Card is equipped with four LED indicators and four toggle switches. Activation of the switch 1-4 shall place a call into SIU Opto 1-4 input respectively.

4. 24-Channel Field Input Termination Assembly

Provide one 24-Channel Field Input Termination Assembly coupled with each 24-Channel Input Assembly. Ensure the 24-Channel Field Input Termination Assembly has enough terminal positions for landing 24 two-wire inputs and their associated earth ground wires. Ensure the Field Input Termination Assembly has positions for 12 Detection Module Suppressors. Supply the Detection Module Suppressors with the cabinet. Ensure the 24-Channel Field Input Termination Assembly is mounted across the rear cabinet EIA rails and swings down to provide access to the back of the assemblies mounted on the opposite side.

Provide a clear cover over the termination assembly to prevent accidental contact with exposed voltage. Ensure cover is easily removable.

5. 32-Channel Output Assembly

Provide one 32-Channel Output Assembly that is 6U high or two 16-Channel Output Assembly that is 3U high rack mounted assembly. The Output Assembly shall accommodate sixteen Model 2202-HV High-Density Switch Pack / Flasher Units (HDSP/FU), providing 96 output circuits. Ensure the Output Assembly accommodates two Model 2218 Serial Interface Unit (SIU) to provide interface and control via system SB1/SB2. Ensure the Output Assembly shall accommodate one Model 2212-HV Cabinet Monitor Unit (CMUip), Main Contactor, Stop Time Switch, Flash / Auto Switch, eight Circuit Breakers and Momentary 24 Vdc Bypass Switch.

6. 32-Channel Field Output Termination Assembly

Ensure the Field Output Termination Assembly is coupled with the 32-Channel Output Assembly and shall house sixteen Model 21H High-Density Flash Transfer Relays (HDFTR). Provide the HDFTRs and Flash Program Blocks (FPB) to control and select the color (red, yellow, or dark) during ATC Cabinet flash mode. Provide the HDSP Suppressors at the field terminals for the protection of the HDSP. Ensure each HDFTR position is labeled with the number of its associated HDSP (1-32) and each FPB position is labeled with the number of its associated channel (1-32).

Provide the Field Output Termination Assembly with touch-safe Phoenix Contact terminal blocks (or approved equal) in accordance with the ATC Standard ATC 5301 v02.02. Ensure each Load Terminal Block receptacle is labeled with the number of its associated channel (1-32). Provide labels or silkscreens to clearly indicate which terminals correspond to the red, yellow, and green switch pack outputs. The color of these labels shall match the color of their associated output (red, yellow, or green).

Provide a 32-Channel Field Output Termination Assembly with each 32-channel Output Assembly.

Mount the 32-Channel Field Output Termination Assembly across the rear cabinet EIA rails and ensure it swings down to provide access to the HDSP Suppressors.

7. 48-Channel Input Assembly

Ensure the Input Assembly is two 3U high rack mounted assembly providing 24 slots of 22/44 pin PCB sockets. Ensure two Model 2218 Serial Interface Units (SIU) are provided

and mated to two DIN 96-pin connectors. Ensure the SIU provides interface and control between the Controller and the detection modules via system SB1/SB2. The Input Assembly shall house 2-channel detection modules only, up to 24 detection modules providing a maximum of 48 channels. Equip the Input Assembly with two Opto Input Cards. Ensure each Opto Input Card is equipped with four LED indicators and four toggle switches. Activation of the switch 1-4 shall place a call into SIU Opto 1-4 input respectively.

8. 48-Channel Field Input Termination Assembly

Provide one 48-Channel Field Input Termination Assembly or two 24- Channel Field Input Termination Assemblies coupled with each 48-Channel Input Assembly. Ensure the 48-Channel Field Input Termination Assembly has enough terminal positions for landing 48 two-wire inputs and their associated earth ground wires. Ensure the Field Input Termination Assembly has positions for 24 Detection Module Suppressors. Supply the Detection Module Suppressors with the cabinet. Ensure the 48-Channel Field Input Termination Assembly is mounted across the rear cabinet EIA rails and swings down to provide access to the back of the assemblies mounted on the opposite side.

Provide a clear cover over the termination assembly to prevent accidental contact with exposed voltage. Ensure cover is easily removable.

4.11. MATERIALS – NEMA TS-1 CABINETS

A. NEMA TS-1 Cabinet Physical Requirements:

Furnish unpainted, natural, aluminum cabinet shells. Ensure that all non-aluminum hardware on the cabinet is stainless steel or a Department approved non-corrosive alternate. Provide a roof with a slope from front to back at a minimum ratio of 1-inch drop per 2 feet. Ensure that each exterior cabinet plane surface is constructed of a single sheet of aluminum and is seamless.

Provide a handle and three point latching mechanism designed to be disassembled using hand tools. Provide a shaft connecting the latching plate to the door handle by passing through the door within a bushing, bearing, or equivalent device. Provide a latching plate at least 3/16 inch thick and that mates securely with the lock bolt. Provide a lock bolt with a flat end (no bevel) and that has at least 1/4 inch of length in contact with the latching plate.

Ensure that the handle and lock are positioned so that the lock does not lie in the path of the rotating handle as the door is unlatched and that the handle points down in the latched position.

Provide a cabinet that is neat in appearance. Provide continuous welds made from the inside wherever possible. On the exterior, provide smooth and flush joints. Ensure there are no superfluous holes in the outside of the cabinet. Ensure that no screws, bolts, nuts or rivets protrude to the outside of the cabinet shell. Ensure cabinet surface is smooth and free of blemishes and discoloration.

Provide a main door opening that encompasses the full frontal area of the cabinet shell exclusive of the area reserved for plenums and flanges. Provide a rear door in base-mounted cabinets, unless otherwise specified. Ensure that the rear door complies with all requirements for the front door, except as follows:

- Hinge rear door on the left side as viewed from the rear of the cabinet shell facing the door.
- No police compartment is required on a rear door.

Ensure that the cabinet shell is sturdy and does not exhibit noticeable flexing, bending or distortion under normal conditions except that a minor amount of flexing is permitted in the main door and rear door only when the cabinet is open. In such case, the flexing must not result in permanent deformation of the door or damage to components mounted on the door. Ensure that pedestal-mounted cabinets have sufficient framing around the slipfitter attachment so that no noticeable flexing will occur at or about this point.

Ensure that the cabinet is large enough to accommodate all of the required equipment, specified future equipment, and wiring within the cabinet to provide sufficient room for servicing. Provide ample space in the bottom of the cabinet for the entrance and forming of all necessary wires and cables without interference with the operation, viewing, and servicing of the equipment. Ensure that the size of the cabinet permits all required and specified future equipment to be mounted in the upright position with sufficient space around it to provide adequate ventilation. Ensure at least 2 inches of clearance is provided around all vents and fans to insure proper air circulation. Ensure the interior size of the cabinets is at least:

Pole- and pedestal-mounted controller cabinets:	4.98 ft ³
Base-mounted controller cabinets:	11.6 ft ³
Pole- and pedestal-mounted on-street master cabinets:	3.5 ft ³
Base-mounted on-street master cabinets:	7.52 ft ³

If specified on the bid list or the plans, controller cabinets as small as 3.3 ft³ may be provided for pole- and pedestal-mounted cabinets provided all other requirements are satisfied. Unless otherwise noted, ensure that cabinets do not exceed the following dimensions:

Maximum Outside Dimensions

Type of Cabinet	Height	Width	Depth
Pole-mounted	52 inches	30 inches	22 inches
Pedestal-mounted	36 inches	30 inches	22 inches
Base-mounted	None	None	None

Provide at least 2 sturdy shelves having an unobstructed depth of at least 13 inches. Ensure top shelf is at least 12 inches below the top of the door opening. Secure any card rack to the walls or shelves. Ensure equipment and components mounted on the cabinet walls require no more than the use of a screwdriver to accomplish their easy removal for servicing. Ensure shelf-mounted units are placed in their proper positions on the shelves without having to twist or turn them during the placement process.

Provide a minimum 12 x 14 inch plastic envelope or container located in the cabinet so that it is convenient for service personnel. Furnish two sets of non-fading cabinet wiring diagrams and schematics in a paper envelope or container and placed in the plastic envelope or container.

Provide a roof with a shield that prevents water from dripping into the cabinet. Equip the roof with a thermostatically controlled exhaust fan and suitably screened exhaust vents that will permit the flow of air for which the fan is rated. Ensure that base-mounted cabinets have a fan rated for at least 12 gal./s and pole- and pedestal-mounted cabinets have a fan rated for at least 6 gal./s. Ensure that the fan does not protrude to the outside of the cabinet and that it is mounted in such a way that it can be easily removed for servicing. Fusing the fan is not required. Ensure that the roof assembly is formed in such a way that it facilitates air exhaust from the fan.

Provide an additional vent or vents at or near the bottom to permit the intake of air. Ensure that the size of the vents permit the flow of air corresponding to the rated flow of the fan. Ensure that the

vents are not smaller than 29.45 in². Equip the vents with standard-size replaceable fiberglass filters. Ensure that the vents do not permit the entrance of rain or snow.

Furnish a fluorescent fixture as required by NEMA TS-2 Specifications with a second lighting fixture mounted under the bottom shelf to light the terminals. Ensure that the second fixture is a fluorescent lighting fixture that complies with NEMA TS-2 Specifications or is a flexible gooseneck fixture containing a protected incandescent reflector bulb of a least 25 Watts. Furnish all bulbs. Ensure that the lamps are door switch actuated.

Provide the cabinet with an adjustable thermostat located in the upper portion of the inside the roof and connected to control the fan. Ensure that it is manually adjustable within the range of at least 78 to 170 degrees F with a calibrated scale. Ensure that the thermostat has contacts rated for use with the fan. Ensure that the thermostat turns the fan on at the set temperature and turns it off when the temperature is 4.5 degrees F below the set temperature.

Provide sufficient electrical and electronic noise suppression in the cabinet to enable all equipment in it to function properly. Ensure cabinet is equipped with one or more radio interference filters connected between the stages of the power line surge protector. Ensure filter(s) minimize interference generated in the cabinet in both the broadcast and aircraft frequencies. Ensure filter(s) provide attenuation of at least 50 decibels over a frequency range of 200 kilohertz to 75 megahertz. Provide filters that are hermetically sealed in metal cases and are insulated. Ensure filter is rated at least at the rated current of the main circuit breaker, 125-volt, 60 Hertz.

B. NEMA TS-1 Cabinet Electrical Requirements:

Provide duplex receptacle in the cabinet located conveniently for service personnel and in such a position that no electrical hazard will be presented to such personnel when using the receptacle. Ensure that the receptacle is a 3-wire ground fault interrupt type that will also accept a standard 2-prong, non-grounding plug. Ensure that the receptacle is reserved for the use of service personnel. Ensure normal control cabinet equipment is not connected to the receptacle.

Provide the cabinet with a NEMA standard circuit breaker box having at least two circuit breakers. Alternatively, provide circuit breakers that are installed in such a way that personnel servicing the cabinet, including the rear of the back panel, cannot inadvertently be exposed to a hazard. Ensure that a terminal block connected to the circuit breakers accommodates service wire as large as Number 6 AWG. Ensure that these circuit breakers are in addition to any fuses that are a part of the individual control equipment components. Provide a clear plastic guard or the equivalent to prevent incidental contact and shock hazard that protects exposed 120-volt AC terminals on the power panel.

Provide a cabinet with a ground bus having at least 20 terminals. Ensure that the bus is attached and electrically bonded to the wall of the cabinet and located conveniently to the traffic signal load circuits. Provide terminals to accommodate Number 10, 12, and 14 AWG conductors. Ensure that at least one terminal on each end is grounded and accommodates a Number 4 AWG conductor.

Provide a cabinet with an AC Neutral bus having at least 24 terminals. Ensure bus is isolated electrically from the cabinet ground. Provide terminals to accommodate Number 10, 12, and 14 AWG conductors. Ensure bus bar is conveniently located near the traffic signal load circuits.

Provide surge suppression in the cabinet and ensure that all devices operate over the temperature range of -40 to 185 degrees F.

Provide a loop surge suppresser for each set of loop terminals in the cabinet. Use terminal mount or stud mount devices for terminating the loop surge suppresser. Ensure that the device can withstand a minimum of 25 peak surge current occurrences at 100A in differential and common

modes for a 10x700 microsecond waveform. Ensure that the maximum breakover voltage is 170V and the maximum on state clamping voltage is 30V. Provide a maximum response time less than 5 nanoseconds and an off state leakage current less than 10 μ A with a nominal capacitance less than 220pf for both differential and common modes.

Provide surge suppression on each communications line entering or leaving a cabinet. Ensure that the communications surge suppresser can withstand at least 80 occurrences of an 8x20 microsecond waveform at 2000A, or a 10x700 microsecond waveform at 400A. Provide a maximum clamping voltage suited to the equipment protected. Provide a maximum response time less than 1 nanosecond with a nominal capacitance less than 1500pf and a series resistance less than 15 Ω .

Ensure that no direct inter-equipment connection is made. Ensure that all equipment is connected to other items of equipment at the cabinet terminal blocks.

Provide the capability for each item of equipment from the cabinet to be removed without disconnecting individual wires. Provide the equipment with suitable MS-type or other multi-pin connectors, or mount in card racks that provide for automatic connection of the card when it is inserted in the rack. Ensure that connectors for the controller A, B and C harnesses, for shelf-mounted detectors and for conflict monitors are metal and separately bonded to the chassis.

Ensure that functionally equivalent equipment is electrically and mechanically interchangeable.

Ensure that all equipment and circuit cards are designed or keyed so that it is physically impossible to connect the unit to the wrong connector or insert it into an incorrect slot. Equip the cabinet with terminal blocks (strips) for the termination of all field conductors and all internal wires and harness conductors. Ensure that all wires are terminated at the terminals. Provide field terminals that are readily accessible without the removal of equipment and located conveniently to the wires, cables and harnesses. Ensure that each terminal block is of electrical grade thermoplastic or thermosetting plastic and each terminal block is a closed back design and has recessed-screw terminals with molded barriers between the terminals.

Ensure that each terminal of a terminal block consists of two terminal screws with a removable shorting bar between them. However, if the terminal block is part of a fabricated panel, each terminal may consist of a single terminal screw with a feed-through binding post to which conductors are soldered behind the panel. Exception: Terminal blocks used for field wiring connections are not required to have removable shorting bars unless required by a specific manufacturer's design. Ensure that each terminal block is labeled with a block designation and each terminal is labeled with a number. Ensure that all terminal functions are also labeled on the back panel or terminal blocks. Provide labels that are visible when the terminal block is fully wired. Ensure that the labels are shown on the cabinet wiring diagrams. Ensure that no terminals are closer than 4 inches to the bottom of the cabinet and provide those in base-mounted cabinets at least 6 inches from the bottom. Ensure that terminals serving similar functions are grouped together. Ensure that no terminals are located on the under side of shelves or at other places where they are not readily visible and accessible or where they may be a hazard to personnel who might inadvertently touch them. Provide police panel, if required, with an enclosure over the terminals of its components to prevent hazard to personnel. Cardboard and other types of flexible covers are not acceptable.

Ensure all equipment in the cabinet is connected to the cabinet, to the other items of equipment, and to the field circuits at the cabinet terminal blocks by means of neatly trained harnesses.

Provide harnesses in the cabinet for non-permanently mounted equipment that are long enough to allow the equipment to be relocated in an upright position to the roof of the cabinet or to be located to the ground 12 inches below cabinet level. Provide a secondary ground conductor of

sufficient size to safely carry any fault current for harnesses that supply power or an AC+ input greater than 24 volts. Ensure that all harnesses are neatly dressed along the cabinet walls either parallel to or perpendicular to the floor. Ensure that they do not run diagonally. Ensure that the harness, which connects the components on the door to the remainder of the cabinet does not touch the doorjamb in any door position, including fully open.

Ensure that each conductor, including unused conductors, within or entering the cabinet is connected to a terminal. Ensure that no more than two conductors are connected to any single terminal screw with the following exception. Multiple conductors may be attached to a terminal used to distribute AC and DC power functions (AC+, AC-, Earth Ground, 24VDC, Logic Ground, etc.) or similar multi-use signals under the following conditions:

- it is unlikely that the conductors attached to such terminals will be removed by the cabinet user and,
- there exists at least one terminal for each of the functions that has two or fewer conductors connected to it that is available for customer use.

This exception does not alter other requirements in these specifications that define the required number of terminals for power or other specific circuits. This provision does not apply to terminals on the load side of the load switches.

Ensure that each conductor has a crimped spade lug when connected to a terminal screw. Terminations to the back panel may be soldered. Connections such as quick connectors and barrel connectors are not acceptable. No in-line splices are permitted in any conductor.

Ensure outgoing circuits are of the same polarity as the line side of the AC supply. Ensure that the common return is of the same polarity as the grounded side of the AC supply.

Ensure all wiring is formed into neatly packaged and neatly dressed harnesses and laced, braided or tied with nylon tie wraps at closely spaced intervals. Where wires, cables or harnesses must be attached to the cabinet walls or door for support or to prevent undue wear or flexing, ensure attachment is made using nylon tie straps or metal clamps with rubber or neoprene insulators. Ensure that these attachment devices are screwed to the cabinet. Stick-on clamps or straps are not permitted.

Ensure that all field wiring and all internal conductors that are likely to be disconnected from time to time are tagged with non-fading, permanent sleeve labels at the ends of the conductors at the terminals. Ensure that sleeve labels are shrunk tightly to grip the conductors. Alternatively, hot stamp labels on the insulation of internal conductors at intervals of no greater than 4 inches. Ensure that all jumpers are wire conductors or metal plates. Using printed circuit back panels or back panels with wire tracks on boards are not permitted.

Provide 3 terminals (2 for loop conductors and 1 for shield) for each loop shown on the plans or required by the bid list. As a minimum, ensure cabinet provides sufficient terminals for 4 loops and detectors in Type 2 cabinets, 8 loops and detectors in Type 4 cabinets, and 16 loops and detectors in Type 8 cabinets. Provide a loop detector surge protector connected to each detector loop input.

Furnish the cabinet with a neatly labeled test switch panel mounted on the inside of the cabinet door. Ensure that the panel contains the following components that are connected to provide the functions indicated. Unless otherwise required, provide switches that are heavy-duty toggle switches.

- 1) **Detector Circuit Test Switch:** Ensure each detector circuit test switch is a three-position (on-normal-momentary on) switch. Ensure each switch is connected to the controller's or communications unit's detector input and in parallel with its associated detector's output so service personnel can place both momentary and constant calls on the device to be actuated.

When in the normal position (center position), ensure switch has no effect on the device to be actuated. In all cases, the detector is to remain connected to the device to be actuated. Provide a detector circuit test switch for each vehicle detector input connected to the controller and each pedestrian detector input to the controller regardless of how many of the controller's phases are in use. In addition, provide detector circuit test switches connected to the system detector inputs of the communications unit if required by the plans or the bid list. As a minimum, provide the following numbers of switches:

Type of Cabinet	Vehicle Detector Switches	Pedestrian Detector Switches
Type 2 cabinet	2	2
Type 4 cabinet	4	4
Type 8 cabinet	8	4

- 2) **Technician Flash Switch:** Provide the test switch panel with a toggle switch for switching the intersection operation between normal stop-and-go (AUTO) operation and flashing operation. Protect this switch against accidental activation by a flip-up switch guard that does not affect switch position when closed.
- 3) **Controller Power Switch:** Provide a test switch panel that contains a toggle switch connected to remove power from the controller and all auxiliary equipment but ensure it does not interrupt power to the flasher. Ensure that this switch is protected against accidental activation by a flip-up switch guard that does not affect switch position when closed.
- 4) **Preemption Test Switches:** Provide a preemption test switch for each distinct preemption operation required by the plans or the bid list. Ensure that the switch is located on the inside of the door or on the left or right inside wall of the cabinet at an easily accessible location. Ensure that the switch is protected against accidental activation by a flip-up switch guard that does not affect switch position when closed.

Provide the cabinet with a police panel that is furnished with the indicated components connected:

- 1) **Police Panel Construction:** Provide a police panel with a door on it in the main door that is accessible when the main door is closed and will not allow water to enter the cabinet when the police door is open. Ensure that the police panel door is hinged on the right side as viewed facing it and has a lock that is keyed with two furnished keys and keyed to a standard police/fire call box key for each cabinet.
- 2) **Emergency Flash Switch:** Provide the police panel with a toggle switch for switching the intersection operation between normal stop-and-go (AUTO) operation and flashing operation.
- 3) **Signal Switch:** Provide the police panel with a toggle switch connected to permit power to be turned on and off to the field signal indicators. When in the off position, ensure that the power it removes is from the field signal indicators and that the controller and all equipment in the cabinet continue to operate normally.
- 4) **Automatic/Manual Switch:** Provide the police panel with a toggle switch connected to switch the intersection operation between normal stop-and-go operation (AUTO) and manual operation (MANUAL) using a hand control. Ensure that the manual control is implemented using only the Manual Control Enable and Interval Advance functions of the controller.
- 5) **Hand Control:** Provide a hand control with each cabinet for the police panel if specifically required by the plans or the bid list. Provide the hand control as a standard traffic signal manual

control push-button connected on one end of a 10 feet coil cord with a 1/4 inch locking phone plug on the other end. Provide a locking phone jack in the police panel for this hand control to effect manual control of the intersection as described above. Ensure the plug and jack lock together so they will not disconnect even when the cord is stretched to its limit. Ensure police panel has room for storage of the hand control.

Provide the cabinet with one or as many as needed solid state flashers to operate the signal displays when the intersection is operated in the flashing mode. Provide the cabinet with a flasher socket for each flasher and make it part of the cabinet back panel. Ensure that the cabinet is wired so that it is possible to select either flashing red or flashing yellow for each signal circuit by switching a jumper plug on the back panel or by switching jumpers using simple hand tools. Ensure that disassembly of and access to the rear of the back panel is not required to effect a flash color change. Ensure that movement of no more than three jumpers is required to change the flash color for any signal circuit. Ensure that the cabinet is wired to effect the switch between normal stop-and-go operation and flashing operation. Provide the following flashing operation:

- Ensure that the controller controls the planned change from stop-and-go operation to flashing operation.
- Ensure that upon actuation of the emergency flash switch in the police panel or the technician flash switch in the test switch panel or upon command of the conflict monitor, the signal indicators are disconnected from the load switches and the appropriate signal indicators are connected to flashing power. Ensure all other signal indicators are dark. Ensure this change takes place immediately upon actuation regardless of the signal indicators being displayed.
- Regardless of the mode of entry into flashing operation, ensure that the return to normal stop-and-go operation occurs only when the controller begins to time the major street WALK interval (green interval if WALK is not used). Ensure that this is accomplished via the activation of the external start input.
- Ensure that the operation of the intersection controller is not affected when the technician flash switch or the communications unit initiates flashing operation, if any, and the controller continues to operate normally. Ensure that the controller stops timing when actuated by the emergency flash switch or the conflict monitor.

Furnish all cabinets, except pretimed cabinets, with optical isolation circuits connected between the pedestrian push-buttons and the pedestrian detector inputs of the controllers and the two-pulse pedestrian detector logic units, if any. Ensure all electronic components for the isolation circuits are contained on a circuit board that can be easily disconnected from its receptacle. Provide isolation circuits for the following number of pedestrian detector circuits:

Type 2 cabinet:	2
Type 4 cabinet:	4
Type 8 cabinet:	4

Ensure that the voltage present at the pedestrian push-buttons does not exceed 24 volts.

C. NEMA TS-1 Conflict Monitors:

Furnish NEMA TS-1 conflict monitor with programming card. Ensure that the absence of the programming card will cause the conflict monitor to trigger, and remain in the triggered state until reset.

Provide a conflict monitor that recognizes the following faults in addition to those specified by NEMA TS-1 Section 6. Ensure that the conflict monitor will trigger as required by the NEMA Specifications:

- Yellow indication missing or shorter than 2.7 seconds (with ± 0.1 second accuracy);
- Walk indication without green vehicle indication on same channel;
- Dual Indications on the same channel.

Ensure that the tests for short and missing yellows and for dual indications be turned on or off per channel. Ensure that the test for walk without green be selectable for each unit. If one of the additional optional fault tests are enabled and an associated fault is detected, ensure that the conflict monitor remains in the triggered state until the unit is reset unless otherwise specified.

When the conflict monitor is triggered, provide a visual indication of the type of event that triggered the unit. Ensure that these indications and the status of each channel be retained until the conflict monitor is reset.

Ensure that the conflict monitor allows user selected latching of the CVM, 24V I, and 24V II inputs. When the conflict monitor is set for latching operation and one of these events is triggered, ensure that the monitor is reset before returning to normal operation.

Provide nonvolatile memory in the conflict monitor that retains a log of events containing the failure type, channel status, date, time for the nine most recent faults, and the date and time of the ten most recent power failures at a minimum. Ensure that the conflict monitor outputs the event log on request to a printer and uploads the event log on request to a Department-furnished personal computer via the RS-232C serial port. Provide the RS-232C serial port mounted on the front.

Provide a conflict monitor with the number of channels required by the plans or bid list. Where required by the plans or bid list, ensure that the conflict monitor is supplied with a wiring harness set. Ensure that the harness is fitted with the proper connector and the harness is 10 feet in length.

4.12. MATERIALS – NEMA TS-2 TYPE 1 CABINETS

A. NEMA TS-2 Type 1 Cabinets General:

Comply with the *NEMA Standards Publication TS-2* (NEMA TS-2) except as otherwise stated herein.

Furnish unpainted, natural, aluminum cabinet shells that comply with Section 7 of NEMA TS-2. Ensure all non-aluminum hardware on the cabinet is stainless steel or a Department approved non-corrosive alternate. Provide a roof with a slope from front to back at a minimum ratio of 1 inch drop per 2 feet. Ensure that each exterior cabinet plane surface is constructed of a single sheet of aluminum and is seamless.

Ensure all components are arranged for easy access during servicing. When modular in construction, provide guides and positive connection devices to insure proper pin alignment and connection.

Provide a moisture resistant coating on all circuit boards.

B. NEMA TS-2 Type 1 Cabinet Physical Requirements:

Provide a handle and three point latching mechanism designed to be disassembled using hand tools. Provide a shaft connecting the latching plate to the door handle by passing through the door within a bushing, bearing, or equivalent device. Provide a latching plate at least 3/16 inch thick and that mates securely with the lock bolt. Provide a lock bolt with a flat end (no bevel) and that has at least 1/4 inch of length in contact with the latching plate.

Ensure that the handle and lock are positioned so that the lock does not lie in the path of the rotating handle as the door is unlatched and that the handle points down in the latched position.

Provide continuous welds made from the inside wherever possible. On the exterior, provide smooth and flush joints. Ensure that no screws, bolts, or rivets protrude to outside of cabinet shell.

Provide a main door opening that encompasses the full frontal area of the cabinet shell exclusive of the area reserved for plenums and flanges. Provide a rear door in base-mounted cabinets, unless otherwise specified. Ensure that the rear door complies with all requirements for the front door, except as follows:

- * Hinge the rear door on the left side as viewed from the rear of the cabinet shell facing the door.
- * No police compartment is required on a rear door.

Ensure that the cabinet shell is sturdy and does not exhibit noticeable flexing, bending or distortion under normal conditions except that a minor amount of flexing is permitted in the main door and rear door only when the cabinet is open. In such case, the flexing must not result in permanent deformation of the door or damage to components mounted on the door. Ensure that pedestal-mounted cabinets have sufficient framing around the slipfitter attachment so that no noticeable flexing will occur at or about this point.

Provide NEMA TS-2, Type 1 cabinets with 2 shelves. Ensure top shelf has an unobstructed depth of at least 12 inches for base-mounted cabinets. Ensure top shelf has an unobstructed shelf depth of at least 13 inches for pole-mounted cabinets. Locate the top shelf at least 12 inches below the top of the door opening. Provide a lower shelf for mounting detector racks, its associated BIU, and other auxiliary equipment. Locate the lower shelf at least 10 inches below the top shelf, and provide at least 13 inches of unobstructed shelf depth. Secure card racks and associated BIU connector housings to the shelf by a removable means. Place the rack so that the front of the rack is not obscured by any object and so that backpanel terminals are not obscured even when the rack is fully utilized.

Provide a back panel hinged at the bottom for access during service.

Provide a minimum 12 x 14 inch plastic envelope or container located in the cabinet so that it is convenient for service personnel.

Furnish two sets of non-fading cabinet wiring diagrams and schematics in a paper envelope or container and placed in the plastic envelope or container.

Do not locate permanently mounted equipment in such a way that will restrict access to terminals.

C. NEMA TS-2 Type 1 Cabinet Electrical Requirements:

Provide a neutral that is not connected to the earth ground or the logic ground anywhere within the cabinet. Ensure the earth ground bus and the neutral ground bus each have ten compression type terminals each of which can accommodate wires ranging from number 14 through number 4.

Provide surge suppression in the cabinet and ensure that all devices operate over the temperature range of -40 to 185 degrees F.

Provide a loop surge suppresser for each set of loop terminals in the cabinet. Use terminal mount or stud mount devices for terminating the loop surge suppresser. Ensure that the device can withstand a minimum of 25 peak surge current occurrences at 100A in differential and common modes for a 10x700 microsecond waveform. Ensure that the maximum breakover voltage is 170V and the maximum on-state clamping voltage is 30V. Provide a maximum response time less than 5

nanoseconds and an off-state leakage current less than 10 μ A. Ensure that a nominal capacitance less than 220pf for both differential and common modes.

Provide surge suppression on each communications line entering or leaving a cabinet. Ensure that the communications surge suppresser can withstand at least 80 occurrences of an 8x20 microsecond waveform at 2000A, or a 10x700 microsecond waveform at 400A. Provide a maximum clamping voltage suited to the equipment protected. Provide a maximum response time less than 1 nanosecond with a nominal capacitance less than 1500pf and a series resistance less than 15 Ω .

Furnish a fluorescent fixture as required by NEMA TS-2 Specifications with a second lighting fixture mounted under the bottom shelf to light the terminals. Ensure that the second fixture is a fluorescent lighting fixture that complies with NEMA TS-2 Specifications or is a flexible gooseneck fixture containing a protected incandescent reflector bulb of at least 25 Watts. Furnish all bulbs. Ensure that the lamps are door switch actuated.

Provide connector type harnesses for all equipment installed in the cabinet, including detector racks. Furnish a harness with connectors to adapt the NEMA TS-2, Type 2 controller "A" connector to the NEMA TS-2, Type 1 "A" connector furnished with the cabinet assembly.

Tag all conductors that are likely to be disconnected from time to time with non-fading, permanent sleeve labels at the ends of the conductors.

In cabinets that are not base mounted, have no terminals closer than 4 inches to the bottom of the cabinet.

Fasten all wiring and harness supports to the cabinet with screws or other removable mechanical means. Do not use adhesives.

Provide harnesses in the cabinet for non-permanently mounted equipment that are long enough to allow the equipment to be relocated in an upright position to the roof of the cabinet or to be located to the ground 1 foot below cabinet level.

Do not locate terminals on the underside of shelves or at other places where they are not readily visible and accessible, or where they may be a hazard to personnel. Provide a clear plastic guard for exposed 120 volt AC terminals on the power panel and the rear of terminal facilities accessible from the rear door.

Provide compression type earth grounds with 10 position terminal buses sized for four Number 14 AWG wires. Provide screw-type terminals for signal feed, detector lead-in, NEMA I/Os, backpanels, and interconnect terminals. Provide screw terminals for all other devices not defined by NEMA TS-2 Specifications. Ensure that wiring by the manufacturer is terminated either on double terminal strips with crimped-on lugs or soldered to rear terminals.

Ensure that upon leaving any cabinet or malfunction management unit (MMU) initiated flashing operation, the controller reverts to its programmed start-up operation through the use of the START UP FLASH CALL feature. Do not require special controller software to implement the return from flash in the start up mode of operation. Wire one of the output relays of the MMU to apply a logic ground to the STOP TIME input for rings 1 and 2 when the MMU initiates flashing operation because of a sensed failure. Ensure that the MMU is interlocked within the cabinet control circuitry as to prevent normal signal operation with the MMU disconnected. Ensure that the 24Vdc supply to the load switches is disconnected when cabinet flashing operation is initialized. Provide a momentary pushbutton, or equivalent method, to apply 24Vdc to the load switches during cabinet flash for troubleshooting purposes.

Unless otherwise required, provide switches that are heavy-duty toggle switches.

Provide a technician panel mounted on the inside of the door with an EQUIPMENT POWER (ON/OFF) switch and an AUTO/FLASH switch. Ensure switches are protected against accidental activation by a flip-up switch guard that does not affect switch position when closed. Provide an EQUIPMENT POWER (ON/OFF) toggle switch that connects or disconnects protected equipment power to all devices in the cabinet and does not affect AC power to the flasher. Provide an AUTO/FLASH toggle switch which immediately places the intersection into flashing operation, disconnects the STOP TIME input generated by the MMU, and applies a logic ground to the LOCAL FLASH STATUS input of the MMU. When placed in the AUTO position, ensure that this switch causes the return of the intersection to normal operation at the programmed start up phases and intervals via the START-UP FLASH CALL feature of the controller unit. Provide a DETECTOR CHANNEL CALL three position detector test switch (on, normal, momentary on) installed for every detector channel in the detector racks. Provide four pedestrian detector test switches (on normal, momentary on) to the 4 pedestrian detector inputs of BIU no. 1. The switches may be installed on the door or on the non-door hinge side of the cabinet at the front of the cabinet.

Provide a police compartment constructed such that neither water nor dust will enter the interior of the cabinet through the police compartment, even when the police compartment door is open. Provide a rigid enclosure over the terminals of its components. Do not use flexible guards. Provide a SIGNAL POWER (ON/OFF) switch, an AUTO/FLASH switch, and an AUTO/MANUAL switch. Provide a locking jack for an optional manual push-button. Provide a SIGNAL POWER (ON/OFF) toggle switch which, when in the "OFF" position, disconnects AC power to the field terminals, applies logic ground to the LOCAL FLASH STATUS input of the MMU, and disconnects the STOP TIME input generated by the MMU. Ensure that a means to prevent recognition of red failure by the malfunction management unit is used and the switch does not affect power to equipment in the cabinet. When the SIGNAL POWER switch is switched to the "ON" position, ensure controller reverts to the programmed start-up phases and intervals via the START-UP FLASH CALL feature of the controller unit. Provide an AUTO/FLASH toggle switch that immediately places the intersection into flashing operation, and applies logic ground to the MMU LOCAL FLASH STATUS input. When placed in the AUTO position, ensure this switch allows the return of the intersection to normal operation at the programmed start-up phases and intervals via THE START-UP FLASH CALL feature of the controller unit. Provide an AUTO/MANUAL toggle switch that selects between normal operation (in the AUTO position) and manually controlled operation (in the MANUAL position). When in the MANUAL position, ensure that a logic ground is applied to the Manual Control Enable input of the controller. Ensure that only when a logic ground signal is applied to Manual Control Enable, the optional manual push-button can be used to advance the phases by applying and removing a logic ground signal to the Interval Advance input.

Provide one flash transfer relay and flasher for each corresponding socket. Provide 2 spare terminals for each flasher circuit output. Provide 1 MMU and 1 cabinet DC power supply (shelf mounted) with all necessary harnesses wired to the appropriate cabinet/back panel termination points. Terminate unused MMU inputs. Provide BIUs with sockets and terminal facilities. BIUs 3 and 4 may be mounted in a rack separate from the back panel.

Provide a minimum of 2 sets of loop terminals and a single earth ground terminal between the 2 sets of loop wire terminals for each slot in each detector rack provided.

In cabinets with less than 16 loadbay positions, provide flash transfer relay circuits for load switches used to implement pedestrian signals that are brought out to separate terminals but not connected for flashing operation when pedestrian signals are assigned to the load switch channel. Ensure that the flash circuit inputs and outputs are available for easy connection to allow conversion

of a pedestrian movement load switch for use as an overlap (vehicle phase) movement load switch. Provide a reserved flash transfer relay circuit for four vehicle movements and all necessary flash transfer relay input and output wiring and flash circuit wiring that can be made available at each pedestrian load switch position.

Comply with the applicable tables for the type of cabinet furnished:

TS-2 Type 1 Cabinet Configurations

CABINET CONFIGURATION	LOAD SWITCH SOCKETS	FLASH RELAY SOCKETS	FLASHER SOCKETS	BIU'S REQUIRED (BACK PANEL/ DETECTOR)	DETECTOR RACK TYPE/ QUANTITY	TS-2 CABINET TYPE*
NC-1	4	2	1	1/1	1/1	4**
NC-2	8	4	1	1/1	2/1	5
NC-3	12	6	1	2/1	2/1	6
NC-3A	12	6	1	2/2	2/2	6
NC-3B	12	6	1	2/2	2/1 1/1	6
NC-4	12	6	1	†3/1	2/1	6
NC-4A	12	6	1	†3/2	2/2	6
NC-4B	12	6	1	†3/2	2/1 1/1	6
NC-5	12	6	1	‡4/1	2/1	6
NC-5A	12	6	1	‡4/2	2/2	6
NC-5B	12	6	1	‡4/2	2/1 1/1	6
NC-6	16	6	1	2/2	2/2	6
NC-6A	16	6	1	2/2	2/1 1/1	6
NC-7	16	6	1	†3/2	2/2	6
NC-7A	16	6	1	†3/2	2/1 1/1	6
NC-8	16	6	1	‡4/2	2/2	6
NC-8A	16	6	1	‡4/2	2/1 1/1	6

*See NEMA TS-2-1998, Table 7-1 for actual dimensions.

**Type 5 cabinet may be substituted for four position base mount cabinet.

† BIU 3 required along with BIU 1, BIU 2, and detector BIU(s).

‡ BIU 3 and BIU 4 required along with BIU 1, BIU 2, and detector BIU(s).

8-Position Loadbay Cabinet Phase Assignments

PHASE /OL NUMBER	MALFUNCTION MANAGEMENT UNIT CHANNEL ASSIGNMENT	ASSIGNED TO LOAD SWITCH POSITION NUMBER	ASSIGNED TO FLASH RELAY NUMBER	ASSIGNED TO FLASHER CIRCUIT/	PROGRAM FLASH COLOR
1	1	1	1	1	R
2	2	2	1	2	Y
3	3	3	2	1	R
4	4	4	2	2	R
2 PED-O/LA †	5	5	†3	†1	D
4 PED O/L .B†	6	6	†3	†2	D
O/L C	7	7	4	1	R
O/L D	8	8	4	2	R

† Prepare this load switch position for the pedestrian movement indicated. Wire pedestrian signals to flash dark. Make flash circuitry for this load switch position available and accessible at a separate terminal to allow connection to the load switch and field terminal circuit for a vehicle movement at a later date if desired.

12-Position Loadbay Cabinet Phase Assignments

PHASE /OL NUMBER	MALFUNCTION MANAGEMENT UNIT CHANNEL ASSIGNMENT	ASSIGNED TO LOAD SWITCH POSITION NUMBER	ASSIGNED TO FLASH RELAY NUMBER	ASSIGNED TO FLASHER TO FLASHER CIRCUIT/	PROGRAM FLASH COLOR
1	1	1	1	1	R
2	2	2	1	2	Y
3	3	3	2	1	R
4	4	4	2	2	R
5	5	5	3	2	R
6	6	6	3	1	Y
7	7	7	4	2	R
8	8	8	4	1	R
2 PED or O/L A†	9	9	†5	†1	D
4 PED or O/L B†	10	10	†5	†2	D
6 PED or O/C†	11	11	†6	†1	D
8 PED or O/L D†	12	12	†6	†2	D

† Prepare this load switch position for the pedestrian movement indicated. Wire pedestrian signals to flash dark. Make flash circuitry for this load switch position available and accessible at a separate terminal to allow connection to the load switch and field terminal circuit for a vehicle movement at a later date.

16 Position Loadbay Cabinet Phase Assignments

PHASE /OL NUMBER	MALFUNCTION MANAGEMENT UNIT CHANNEL ASSIGNMENT	ASSIGNED TO LOAD SWITCH POSITION NUMBER	ASSIGNED TO FLASH RELAY NUMBER	ASSIGNED TO FLASHER CIRCUIT/	PROGRAM FLASH COLOR
1	1	1	1	1	R
2	2	2	1	2	Y
3	3	3	2	1	R
4	4	4	2	2	R
5	5	5	3	2	R
6	6	6	3	1	Y
7	7	7	4	2	R
8	8	8	4	1	R
2 PED	9	9	-	-	D
4 PED	10	10	-	-	D
6 PED	11	11	-	-	D
8 PED	12	12	-	-	D
O/L A	13	13	5	1	R
O/L B	14	14	5	2	R
O/L C	15	15	6	1	R
O/L D	16	16	6	2	R

Provide flasher circuits and flash transfer relay outputs and inputs that are brought out to terminals which provide a convenient means of changing flash color and flash circuit at each load switch position. Ensure that changing flash color of a given phase or overlap involves no more than moving three wires. Ensure that the selected phase or overlap flash color load switch output is easily movable to connect to the normally open flash transfer relay input assigned to the phase or overlap. Ensure that the common output of the flash transfer relay circuit assigned to the phase or overlap is easily movable to the selected field terminal (input) of the phase or overlap flash color. Ensure that the non-flashed load switch output is easily moved to provide power directly to the phase or overlap field terminal for that color.

In cabinets requiring a Type 1 detector rack, route to and terminate on a conveniently located terminal block on the back panel or elsewhere in the cabinet, the eight unused detector BIU Vehicle Call inputs. Tie the 8 unused detector BIU Detector Status inputs to the logic ground.

Provide detector racks and associated detector rack BIUs that are removable and replaceable from the cabinet either as a complete assembly or separately. Ensure that disconnection and reconnection of these units is through quick disconnect type connectors.

4.13. MATERIALS – TYPE 170 DETECTOR SENSOR UNITS

Furnish detector sensor units that comply with Chapter 5 Section 1, “General Requirements,” and Chapter 5 Section 2, “Model 222 & 224 Loop Detector Sensor Unit Requirements,” of the

CALTRANS “Transportation Electrical Equipment Specifications” dated March 12, 2009 with Erratum 1.

4.14. MATERIALS – NEMA TS-1 DETECTORS

Furnish NEMA TS-1 single-channel or multi-channel detectors.

Provide multi-channel detectors that sequentially scan each of its channels. Ensure that the multi-channel detectors can turn a channel off and disable its operation from the front panel.

Provide channels with a minimum of eight sensitivity levels.

Ensure detector units meet the requirements of NEMA TS-1 Specifications except as follows:

- Class 2 vehicle output is maintained for a minimum of 4 minutes, and
- Class 3 vehicle output is maintained for a minimum of 30 minutes, maximum 120 minutes.

Where required, furnish detectors equipped with required timing features. Provide a delay that is settable in one-second increments (maximum) over the range of zero to thirty seconds. Provide an extend that is settable in 1/4 second increments (maximum) over the range of 0 to 15 seconds. Provide detectors that can set both delay and extend timing for the same channel. If both timings are set, ensure the delay operates first. After the delay condition has been satisfied, ensure that the extend timer operates normally and that it is not necessary to satisfy the delay timing for an actuation arriving during the extend portion.

Ensure detectors register a permanent call during tuning operations, as a result of a loop fault, and when power is removed. Ensure detectors completely self-tune within 10 seconds after application of power or restoration of interrupted power and within 10 seconds after correction of a loop fault.

Provide detectors that monitor the loop for fault conditions on each channel. Upon detection of a fault condition, even if the condition is subsequently corrected, ensure the detectors provide an indication of the occurrence and maintain the indication until a manual reset. The fault conditions are:

- An open-circuited loop system;
- A short to ground; and
- A 25 percent reduction in inductance.

Ensure a two-channel detector operates normally with the same loop connected to both channels.

Provide lightning and surge protection that is incorporated into the design of the detector. Ensure that each channel operates properly when used with the loop detector surge protector.

In addition to NEMA TS-1 Specifications, ensure each channel is capable of tuning to and operating on any loop system inductance within the range of 50 to 2,000 μ h. Ensure that the channel will operate properly even on a loop system that has a single-point short to earth ground.

Provide detectors with a durably finished nonferrous housing. Ensure that the removal of the housing can be accomplished by using simple hand tools. Ensure each printed circuit board has a moisture resistant coating and that the components are readily accessible with the housing removed.

Provide a wiring harness with a minimum length of 6 feet for each detector. Ensure each wire is permanently labeled, numbered, or color-coded.

4.15. MATERIALS – NEMA TS-2 DETECTOR CARDS AND RACKS

Furnish NEMA TS-2 multi-channel detector cards and racks.

Provide cards that sequentially scan each of its channels. Provide channels with a minimum of eight sensitivity levels.

On a multi-channel detector, ensure that it is possible to turn a channel off and disable its operation from the front panel.

Ensure that detector units meet the requirements of NEMA TS-2 Specifications except as follows:

- Class 2 vehicle output is maintained for a minimum of 4 minutes, and
- Class 3 vehicle output is maintained for a minimum of 30 minutes, maximum 120 minutes.

Where required, furnish detector cards equipped with required timing features. Provide a delay that is settable in one second increments (maximum) over the range of zero to thirty seconds. Provide an extend that is settable in 1/4 second increments (maximum) over the range of 0 to 15 seconds. Provide cards that can set both delay and extend timing for the same channel. If both timings are set, ensure that the delay operates first. After the delay condition has been satisfied, ensure that the extend timer operates normally and that it is not necessary to satisfy the delay timing for an actuation arriving during the extend portion.

Ensure that two-channel detector cards operate normally with the same loop connected to both channels.

Provide lightning and surge protection that is incorporated into the design of the detector. Ensure that each channel operates properly when used with the loop detector surge protector.

In addition to NEMA TS-2 Specifications, ensure that each channel is capable of tuning to and operating on any loop system inductance within the range of 50 to 2,000 μh. Ensure that the channel will operate properly even on a loop system that has a single-point short to earth ground.

4.16. MEASUREMENT AND PAYMENT

Actual number of Department Supplied 2070 Controllers installed and accepted.

Actual number of each type of Cabinets Without Controllers furnished, installed, and accepted.

Payment will be made under:

Department Supplied 2070 Controller	Each
Cabinet Without Controller (_____).....	Each

5. PUSH BUTTON INTEGRATED ACCESSIBLE PEDESTRIAN SIGNAL (APS)

5.1. DESCRIPTION

Furnish and install push button integrated accessible pedestrian signals that include pedestrian pushbutton, pushbutton locator tone, raised tactile arrow, audio and vibro-tactile walk indications, automatic volume adjustment, pedestrian information sign, and all necessary hardware. Furnish the R10-3e with appropriate arrow direction for the pedestrian information sign.

5.2. MATERIALS

Furnish material, equipment, and hardware under this section that is pre-approved on the ITS and Signals QPL.

Provide the accessible pedestrian signals with a 2-inch diameter pedestrian push button that contains a tactile arrow whose direction can be easily adjusted in the field. Ensure each push button actuates a sturdy, momentary, normally-open switch with a minimum rating of 20 million actuations. Include on the button, a raised tactile arrow having a high visual contrast with the remainder of the button face. Ensure the housing is weather-tight and fabricated from aluminum. Ensure the housing is suitable for mounting on wood and metal poles. Paint surfaces of the pedestrian push button

housing in highway yellow, unless otherwise specified, with an electrostatically-applied, fused-polyester paint method. Ensure the thickness of the paint is a minimum of 2.5 mils. Provide the pedestrian information sign that is integral to the housing.

Ensure the accessible pedestrian signals can provide tones, sounds, and speech messages that are synchronized at an intersection. Provide a means for adjusting the base sound level for the tones, sounds, and speech messages. Ensure the tones, sounds, and speech messages will adjust automatically to the ambient noise level up to a maximum of 100 dBA. Provide the custom speech messages in both English and Spanish languages. Ensure you can program the accessible pedestrian signal by a means not readily accessible by unauthorized persons.

Ensure each push button provides a standard locator tone that is deactivated when the traffic signal is operating in the flash mode. Provide a user-programmable audible beaconing feature that is initiated by an extended push button press of one second or more. Ensure the audible beaconing feature increases the volume of the push button locator tone during the pedestrian change interval of the called pedestrian phase and operates in one of the following ways:

- A. The louder audible walk indication and louder locator tone comes from the far end of the crosswalk, as pedestrians cross the street,
- B. The louder locator tone comes from both ends of the crosswalk, or
- C. The louder locator tone comes from an additional speaker that is aimed at the center of the crosswalk and that is mounted on a pedestrian signal head.

Provide confirmation of the push button activation by an LED pilot light. Ensure the pilot light remains illuminated until the pedestrian's green or WALKING PERSON (symbolizing WALK) signal indication is displayed. Ensure each press of the pushbutton initiates a "wait" speech message during all intervals except the Walk interval.

Ensure you can select a percussive tone and custom speech message to sound during the "Walk" interval. Provide a push button that vibrates during the "Walk" interval. Ensure the "Walk" indications have the same duration as the illuminated pedestrian signals except when the signal is programmed to rest in the walk interval. When the pedestrian signal is programmed to rest in walk, ensure the "Walk" indication is limited to the first 7 seconds of the walk interval. The "Walk" indication shall be recalled by a button press during the walk interval provided that the crossing time remaining is greater than the pedestrian change interval. Ensure the "Walk" indications are deactivated when the traffic control signal is operating in a flashing mode. When audible "Walk" indications are selected as a percussive tone, ensure the tone repeats at 8 to 10 ticks per second and consists of multiple frequencies with a dominant component at 880 Hz.

Ensure the accessible pedestrian signals are weatherproof and suitable for operation in wet locations. Ensure proper operation over a temperature range of -30°F (-34°C) to 165°F (+74°C). Ensure all circuit boards have a moisture resistant coating. Ensure the equipment interfaces and operates properly in a Type-170E cabinet.

If the accessible pedestrian signal is required by the Engineer to have a touchless feature, then ensure a pedestrian call is placed when a hand is waved from 1 to 6 inches across the front of the Push Button.

5.3.CONSTRUCTION METHODS

Comply with the requirements of Section 1705 of the *Standard Specifications*. Install in accordance with the manufacturer's recommendations.

Mount push button integrated accessible pedestrian signals in a tamperproof manner on wood and metal poles, signal pedestals, or pushbutton posts as indicated in the signal plans.

Install each pushbutton so that the tactile arrow is pointed in the direction of travel and is aligned parallel to the direction of travel on the associated crosswalk.

Ensure pushbuttons are separated by a distance of at least 10 feet such that they clearly indicate which crosswalk has the WALK indication. Where there are constraints on a particular corner that make it impractical to provide the 10 feet of separation between the two pushbuttons, the pushbuttons may be placed closer together or on the same pole, with approval by the Engineer. If two pushbuttons are placed on the same pole or with less than 10 feet separation, provide a speech walk message for the WALK indication and a speech pushbutton information message.

Adjust the intensity of the pushbutton locator tones so they are audible 6 feet to 12 feet from the pushbutton, or to the building line, whichever is less. Ensure the pushbutton locator tones are no more than 5 dBA louder than ambient sound. Configure audible "Walk" indication to be audible at the nearest end of the associated crosswalk.

If speech messages are used, have each recorded custom speech message approved by the Engineer in advance.

5.4. MEASUREMENT AND PAYMENT

Actual number of push button integrated accessible pedestrian signal detector stations furnished, installed, and accepted.

Actual number of central control units for APS detector stations furnished, installed, and accepted.

No measurement will be made of cables or hardware, as these will be considered incidental to furnishing and installing push button integrated accessible pedestrian signals.

Payment will be made under:

APS Detector Stations.....	Each
Central Control Units For APS Detector Stations	Each

6. VIDEO IMAGING LOOP EMULATOR DETECTOR SYSTEMS FOR TEMPORARY INSTALLATION

6.1. DESCRIPTION

Design, furnish, provide training, and install video imaging loop emulator detection systems with all necessary hardware for temporary traffic signals in accordance with the plans and specifications.

Unless otherwise specified in the contract, all loop emulator detection equipment will remain the property of the contractor.

6.2. MATERIALS

A. General:

Material and equipment furnished under this section must be pre-approved on the Department's QPL by the date of installation except miscellaneous hardware such as cables and mounting hardware do not need to be pre-approved.

Used equipment will be acceptable provided the following conditions have been met:

- Equipment is listed on the current QPL.
- Equipment is in good working condition.
- Equipment is to remain the property of the contractor.

Ensure that software is licensed for use by the Department and by any other agency responsible for maintaining or operating the loop emulation system. Provide the Department with a license to duplicate and distribute the software as necessary for design and maintenance support.

Design and furnish video imaging loop emulator detection systems that detect vehicles at signalized intersections by processing video images and providing detection outputs to the signal controller in real time (within 112 milliseconds of vehicle arrival).

Furnish all required camera sensor units, loop emulator processor units, hardware and software packages, cabling, poles, mast arms, harnesses, camera mounting assemblies, surge protection panels, grounding systems, messenger cable and all necessary hardware. Furnish systems that allow the display of detection zones superimposed on an image of the roadway on a Department-furnished monitor or laptop computer screen. Ensure detection zones can be defined and data entered using a simple keyboard or mouse and monitor, or using a laptop PC with software.

Provide design drawings showing design details and camera sensor unit locations for review and acceptance before installation. Provide mounting height and location requirements for camera sensor units on the design based on site survey. Design video imaging loop emulator detection systems with all necessary hardware. Indicate all necessary poles, spans, mast arms, luminaire arms, cables, camera mounting assemblies and hardware to achieve the required detection zones where Department owned poles are not adequate to locate the camera sensor units. Do not design for the installation of poles in medians.

Obtain the Engineer's approval before furnishing video imaging loop emulator detection systems. The contractor is responsible for the final design of video imaging loop emulator detection systems. Review and acceptance of the designs by the Department does not relieve the contractor from the responsibility to provide fully functional systems and to ensure that the required detection zones can be provided.

Provide the ability to program each detection call (input to the controller) with the following functions:

- Full Time Delay – Delay timer is active continuously,
- Normal Delay – Delay timer is inhibited when assigned phase is green (except when used with TS 2 and 170/2070L controllers),
- Extend – Call is extended for this amount of time after vehicle leaves detection area,
- Delay Call/Extend Call – This feature uses a combination of full time delay and extend time on the same detection call. Ensure operation is as follows: Vehicle calls are received after the delay timer times out. When a call is detected, it is held until the detection area is empty and the programmed extend time expires. If another vehicle enters the detection area before the extend timer times out, the call is held and the extend time is reset. When the extend timer times out, the delay timer has to expire before another vehicle call can be received.

Provide the ability to program each detection zone as one of the following functions:

- Presence detector,
- Directional presence detector,
- Pulse detector,
- Directional pulse detector.

Ensure previously defined detector zones and configurations can be edited.

Provide each individual system with all the necessary equipment to focus and zoom the camera lenses without the need to enter the camera enclosure.

Provide systems that allow for the placement of at least 8 detection zones within the combined field of view of a single camera sensor unit. Provide a minimum of 8 detection outputs per camera.

Provide detection zones that can be overlapped. Ensure systems reliably detect vehicles when the horizontal distance from the camera sensor unit to the detection zone area is less than ten times the mounting height of the sensor. Ensure systems detect vehicles in multiple travel lanes.

Ensure systems can detect vehicle presence within a 98 to 102 percent accuracy (up to 2 percent of the vehicles missed and up to 2 percent of false detection) for clear, dry, daylight conditions, a 96 to 105 percent accuracy (up to 4 percent of the vehicles missed and up to 5 percent false detection) for dawn and dusk conditions, and a 96 percent accuracy (up to 4 percent of the vehicles missed) for night and adverse conditions (fog, snow, rain, etc.) using standard sensor optics and in the absence of occlusion.

Repair and replace all failed components within 72 hours.

The Department may conduct field-testing to ensure the accuracy of completed video imaging loop emulator detection systems.

B. Loop Emulator System:

Furnish loop emulator systems that receive and simultaneously process information from camera sensor units, and provides detector outputs to signal controllers.

Ensure systems provide the following:

- Operate in a typical roadside environment and meet the environmental specifications and are fully compatible with NEMA TS 1, NEMA TS 2, or Type 170/2070L controllers and cabinets,
- provide a “fail-safe” mode whereby failure of one or more of the camera sensor units or power failure of the loop emulator system will cause constant calls to be placed on the affected vehicle detection outputs to the signal controller,
- provide compensation for minor camera movement of up to 2 percent of the field of view at 400 feet without falsely detecting vehicles,
- process the video at a minimum rate of 30 times per second,
- provide separate wired connectors inside the controller cabinet for video recording each camera,
- provide remote video monitoring with a minimum refresh rate at 1 frame per second over a standard dial-up telephone line,
- provide remote video detection monitoring.

Furnish camera sensor units that comply with the following:

- have an output signal conforming to EIA RS-170 standard,
- have a nominal output impedance of 75 ohms,
- be immune to bright light sources, or have built in circuitry or protective devices to prevent damage to the sensor when pointed directly at strong light sources,
- be housed in a light colored environmental enclosure that is water proof and dust tight, and that conforms to NEMA-4 specifications or better,

- simultaneously monitor at least five travel lanes when placed at the proper mounting location with a zoom lens,
- have a sunshield attached to the environmental enclosure to minimize solar heating,
- meet FCC class B requirements for electromagnetic interference emissions,
- have a heater attached to the viewing window of the environmental enclosure to prevent ice and condensation in cold weather.

Where coaxial video cables and other cables are required between the camera sensor and other components located in the controller cabinet, furnish surge protection in the controller cabinet.

If furnishing coaxial communications cable comply with the following, as recommended by the approved loop emulator manufacturer:

- Number 20 AWG, solid bare copper conductor terminated with crimped-on BNC connectors (do not use BNC adapters) from the camera sensor to the signal controller cabinet.
- Number 22 AWG, stranded bare copper conductor terminated with crimped-on BNC connectors (do not use BNC adapters) from the camera sensor unit to the junction box, and within the signal controller cabinet.

Furnish power cable appropriately sized to meet the power requirements of the sensors. At a minimum, provide three conductor 120 VAC field power cable.

As determined during the site survey, furnish sensor junction boxes with nominal 6 x 10 x 6 inches dimensions at each sensor location. Provide terminal blocks and tie points for coaxial cable.

C. Video Imaging Loop Emulator System Support:

Furnish video imaging loop emulator systems with either a simple keyboard or a mouse with monitor and appropriate software, or with system software for use on department-owned laptop PCs. Ensure the system is Windows 2000 and Windows XP compatible.

Provide Windows 2000 and Windows XP compatible personal computer software, if needed, to provide remote video and video detection monitoring.

Ensure systems allow the user to edit previously defined detector configurations. When a vehicle is within a detection zone, provide for a change in color or intensity of the detection zone perimeter or other appropriate display changes on the Department-furnished monitor or laptop computer screen.

Provide cabling and interconnection hardware with 6-foot minimum length interconnection cable to interface with the system.

Provide all associated equipment manuals and documentation.

6.3. CONSTRUCTION METHODS

Arrange and conduct site surveys with the system manufacturer's representative and Department personnel to determine proper camera sensor unit selection and placement. Provide the Department at least 3 working days notice before conducting site surveys. Upon completion of the site surveys the Department will provide revised plans reflecting the findings of the site survey.

Before beginning work at locations requiring video imaging loop emulator detection systems, furnish system software. Upon activation of detection zones, provide detector configuration files. Ensure that up-to-date detection configuration files are furnished for various detection zone configurations that may be required for construction phasing.

Place into operation loop emulator detection systems. Configure loop emulator detection systems to achieve required detection in designated zones. Have a certified manufacturer’s representative on site to supervise and assist with installation, set up, and testing of the system.

Install the necessary processing and communications equipment in the signal controller cabinet. Make all necessary modifications to install equipment, cabling harnesses, and camera sensor interface panels with surge suppression.

Perform modifications to camera sensor unit gain, sensitivity, and iris limits necessary to complete the installation.

Do not install camera sensor units on signal poles unless approved by the Engineer.

Install the necessary cables from each sensor to the signal controller cabinet along signal cabling routes. Install surge protection and terminate all cable conductors.

Relocate camera sensor units and reconfigure detection zones as necessary according to the plans for construction phases.

Provide at least 8 hours of training on the set up, operation, troubleshooting, and maintenance of the loop emulator detection system to a maximum of ten Department personnel. Arrange for training to be conducted by the manufacturer’s representative at an approved site within the Division responsible for administration of the project. Thirty days before conducting training submit a detailed course curriculum, draft manuals and materials, and resumes. Obtain approval of the submittal before conducting the training. At least one week before beginning training, provide three sets of complete documentation necessary to maintain and operate the system. Do not perform training until installation of loop emulator detection systems is complete.

6.4. MEASUREMENT AND PAYMENT

Actual number of site surveys, arranged, conducted, and accepted.

Actual number of luminaire arms for temporary video systems furnished, installed, and accepted.

Actual number of cameras with internal loop emulator processing units furnished, installed, and accepted.

Actual number of cameras without internal loop emulator processing units furnished, installed, and accepted.

Actual number of external loop emulator processing units furnished, installed, and accepted.

Actual number of temporary camera sensor units relocated with detection zones reconfigured installed, and accepted.

No measurement will be made of video imaging loop emulator system support or training, power and video cables, and trenching as these items will be considered incidental to furnishing and installing video imaging loop emulator detection systems.

Payment will be made under:

Site Survey	Each
Luminaire Arm for Temporary Video System.....	Each
Camera with Internal Loop Emulator Processing Unit.....	Each
Camera without Internal Loop Emulator Processing Unit.....	Each
External Loop Emulator Processing Unit	Each
Relocate Temporary Camera Sensor Unit	Each

7. VIDEO DETECTION SYSTEMS

7.1. DESCRIPTION

A. General

Design, furnish, provide training, and install detection systems with all necessary hardware in accordance with the plans and specifications. Ensure the firmware and software furnished and installed as part of an Intelligent Transportation System (ITS) or traffic signal project are the most current and approved releases or versions, unless otherwise requested by the Department. Provide all equipment, materials, and work in accordance with all manufacturers' recommendations. All equipment, cables, and hardware must be part of an engineered system that is designed by the manufacturer to fully interoperate with all other system components.

Provide a video detection system which provides presence detection, vehicle counts, vehicle classification, and per-lane occupancy. The video detection system includes, but is not limited to, camera image sensor(s), including the detector housing, mounting hardware, a video detection system processor, system management software, cabling between the detector and the cabinet, surge suppressors, terminations, output expansion modules which mount in the traffic signal controller cabinet input files, vertical conduit, weather heads and related equipment. The video detection system processor shall have the ability to communicate with Transportation Management Center (TMC) computers to remotely view live camera images. The detection video shall be encoded within the video detection system processor to MPEG4 or H.264 digital video format and be able to be viewed at the TMC without the use of external encoders.

7.2. MATERIALS

A. General

Material and equipment furnished under this specification must be pre-approved on the Department's QPL by the date of installation. Miscellaneous hardware such as cables and mounting hardware do not need to be pre-approved.

Furnish video detection systems with either a simple keyboard or a mouse with monitor and appropriate software, or with system software for use on Department owned laptop PCs. Provide software compatible with the latest NCDOT-approved version of Microsoft Windows to provide remote video and video detection monitoring.

Ensure that software furnished is licensed for use by the Department and by any other agency responsible for maintaining or operating the system. Provide the Department with a license to duplicate and distribute the software as necessary for design and maintenance support.

Design and furnish video detection systems that detect vehicles by processing video images and provide detection outputs in real time.

Furnish all required camera sensor units, detection system processor units, software packages, cabling, poles, mast arms, harnesses, camera mounting assemblies, surge protection panels, grounding systems, messenger cable, and all necessary hardware.

Furnish systems that allow the display of detection zones superimposed on an image of the roadway on a Department furnished monitor or laptop computer screen. Ensure detection zones can be defined and data entered using a simple keyboard or mouse and monitor, or using a laptop PC with software.

Provide design drawings showing design details and camera sensor unit locations for review and acceptance before installation. Provide mounting height and location requirements for camera sensor units on the design based on the site survey. Design video detection systems with all necessary hardware. Do not design for the installation of poles in medians.

Obtain the Engineer's approval before furnishing video detection systems. The contractor is responsible for the final design of video detection systems. Review and acceptance of the designs by the Department does not relieve the contractor from the responsibility to provide fully functional systems and to ensure that the required detection zones can be provided.

Provide all associated equipment manuals and documentation.

Use a video camera sensor that is compatible with the video detection system processor and meets the following technical and functional requirements:

1. Requirements

1.1 Video Camera Sensor

Furnish and install a video camera sensor that is compatible with intersection applications. Send a video signal or thermal video image from the video camera sensor to the processor for real-time vehicle detection. Utilize high-sensitivity optics in the video camera sensor or thermal imaging to compensate for variations in lighting conditions, including blooming at night caused by headlights, rain and ice glare, and sun position shadowing. Include a heater at the front of the enclosure, or alternate method, to prevent the formation of ice and condensation in cold weather. Ensure that the heater does not interfere with the operation of the video camera sensor electronics, or cause interference with the video signal, where applicable. As a minimum, meet the following requirements for each video camera sensor assembly installation:

- Signal to Noise Ratio shall be greater than 50 dB.
- The digital video standard should be compliant with MPEG4 or H.264. Digital video conforming to newer standards than this may be acceptable at the Engineer's discretion.
- A minimum resolution of 640x480 pixels.
- For Electromagnetic interference, ensure compliance with FCC Part 15, Subpart B, Class A device requirements, which apply to the video camera sensor and associated connected equipment in their installed condition.
- Furnish power cable appropriately sized to meet the power requirements of the sensors. At a minimum, provide three-conductor 120 VAC field power cable. Size the power conductors from the power source to the camera input so that no more than a 3% voltage drop is experienced (NEC 210-19 a., FPN No. 4). Provide power from the cabinet power source through a surge suppressor and then to the video camera sensor.
- If the sensors support Power-over-Ethernet, provide any external POE injectors that are required. Ensure the POE injectors meet the following minimum requirements:
 - Working temp/humidity: 14° F to 131° F/maximum 90%, non-condensing

- Connectors: Shielded RJ-45, EIA 568A and EIA 568B
- Input Power: 100 to 240 VAC, 50 to 60 Hz
- Pass Through Data Rates: 10/100/1000 Mbps
- Regulatory: IEEE 802.3bt (POE)
- Number of Ports: 1 In and 1 Out
- Safety Approvals: UL Listed
- Ensure the POE Injector is designed for Plug-and-Play installation, requiring no configurations and supports automatic detection and protection of non-standard Ethernet Terminal configurations.
- The video camera sensor shall be installed in a light-colored enclosure to limit solar heating. Meet NEMA 250 Type 4 enclosure standards for the enclosure and seal the enclosure to prevent sand, dirt, dust, salt, and water from entering. Affix a sun shield visor to the front of the enclosure which is sufficiently adjustable to divert water away from the video camera sensor lens and prevent direct sunlight from entering the iris when mounted in its installed location.
- All connections to the camera sensor assembly shall be professionally sealed to manufacturer recommendations to ensure a waterproof connection.
- Where coaxial video cables, power cables, and other cables are required between the camera sensor assembly and other components located in the controller cabinet, furnish surge protection in the controller cabinet.
- If furnishing coaxial video cable, comply with manufacturer recommendations.
- Provide terminal blocks and tie points for coaxial cable.
- Environmental: Ensure that temperature and humidity limits of the sensor adhere to NEMA TS2-2003 requirements.
- Shock and Vibration: Ensure the sensor adheres to shock and vibration requirements of NEMA TS2-2003.

1.2 Video Detection System Processor

Furnish video detection system processors that detect vehicles by processing video images and provide detection outputs in real time. The video detection system processor shall accept inputs from cameras installed at the intersection such that signals from one or more video camera sensors, or other synchronous or non-synchronous video source, can be processed in real time. If required, additional video detection system processors should be provided to handle the number of cameras installed at the location. As a minimum, meet the following requirements for each video detection system processor installation:

- Provide an IP addressable processor module, which performs video image processing and MPEG4 or H.264 encoding.
- Provide a “fail-safe” mode whereby failure of one or more of the camera sensor units or power failure of the system will cause constant calls to be placed on the affected detection outputs.

- Provide compensation for minor camera movement of up to 2 percent of the field of view at 400 feet without falsely detecting vehicles.
- Include detection indicators on the front panel of the processor module for each channel of detection provided through that module to indicate detector output in real time when the system is operational.
- Include an RJ-45 Ethernet port connector on the system processor to enable communication from a programming device.
- Provide the ability to remotely monitor video and video detection.
- Ensure the system supports both NEMA TS-2 SDLC communications and wired I/O interface for integration into Caltrans Type 170 cabinets or NEMA TS-2 type cabinets.
- Provide a video detection system processor that operates reliably in a typical roadside traffic cabinet environment.
- Environmental: Ensure that temperature and humidity limits of the system processor adhere to NEMA TS2-2003 requirements.
- Shock and Vibration: Ensure the sensor adheres to shock and vibration requirements of NEMA TS2-2003.

Ensure processor modules that plug into a detector rack or input file meet the following requirements:

- Ensure the processor module completely fits within the loop detector slots of the traffic signal controller cabinet input file and that provides a standard relay closure detector input to the controller.
- Provide from one to four detector outputs through the processor module which communicate through the input file edge card connector.
- Use a module that is not wider than two standard input file slots.
- Provide power to the processor modules through the signal cabinet detector input file.

2. **Functional Requirements for Video Detection Systems**

Provide the ability to program each detection call (input to the controller) with the following functions:

- Full Time Delay – Delay timer is active continuously,
- Extend – Call is extended for this amount of time after vehicle leaves detection area,

Delay Call/Extend Call – This feature uses a combination of full time delay and extend time on the same detection call. Ensure operation is as follows: Vehicle calls are received after the delay timer times out. When a call is detected, it is held until the detection area is empty and the programmed extend time expires. If another vehicle enters the detection area before the extend timer times out, the call is held and the extend time is reset. When the extend timer times out, the delay timer must expire before another vehicle call can be received.

Ensure that Video Detection Systems provides presence detection, vehicle counts, vehicle classification, and per-lane occupancy. Verify that the system can, at a minimum, emulate the output of a pair of 6 ft. by 6 ft. in-pavement loops spaced 16 ft. apart.

Provide the capability to create detection zones of varying size and shape to allow the best coverage of the viewable roadway lanes and ramps. Provide the capability to save the detection zone format on the processor module card once drawn for a particular video camera sensor image.

Ensure the system allows the user to edit previously defined detector configurations. Ensure the system user can use a laptop to reprogram, calibrate, adjust or alter any previously defined detector configurations in the field and reprogram any detector configurations over the network or from a remote location.

Ensure detection zones can be overlapped. Ensure the system can detect vehicles in multiple travel lanes.

Detect either approaching or receding vehicles in multiple lanes within the field of view (FOV) of each video camera sensor. Provide the capability of detecting vehicles in at least 24 detection zones per video camera sensor with the detection system. Allow the detection zones to be combined to form one output.

When a vehicle is within a detection zone, provide for a change in color or intensity of the detection zone perimeter or other appropriate display changes on the monitor or Department furnished laptop computer screen.

Verify that any traffic data collected by the video detection system and the system configuration is stored within internal non-volatile memory within the video detection system processor. Perform software updates through an Ethernet, serial, or USB port. Verify that data can be retrieved from the system either locally or via requests from computers at the central Transportation Management Center (TMC) over the communications network.

Ensure the video detection system includes computer software, which enables the user to program, calibrate, operate, and view current status of all system features using a laptop computer, or network-connected workstation at the central TMC. Ensure the system allows the user to view live MPEG4 or H.264 video from the image sensor with the programmed detectors overlaying the image. Ensure individual vehicle actuations can be viewed while observing the live MPEG4 or H.264 encoded video.

Ensure the video detection system configuration data can be uploaded and saved to a laptop or TMC workstation computer for later re-loading to the video detection processor if necessary.

Verify that the detection system is IP-addressable and that all communication addresses are user programmable. Ensure the setup program assigns an IP address to the detection processor.

Ensure the video detection system processor front panel includes a visual display of the status of each video input. Indicators shall display, at a minimum, the status of video detection system processor communications, the status of the video detection system processor, the status of communications, and whether each video camera

sensor is actively detecting. The video processor shall allow a remote user to gain remote access, collect data, control, and configure the VDS.

3. Accuracy Requirements for Video Detection Systems

Provide a video detection system that meets the below minimum accuracy requirements:

Parameter	Condition	Accuracy	False Detection	Missed Detection
Presence Detection	Daytime	97% - 105%	5%	3%
Presence Detection	Nighttime	97% - 115%	15%	3%
Presence Detection	Adverse Weather	97% - 115%	15%	3%

Parameter	Condition	Accuracy	False Detection	Missed Detection
Vehicle Counts	Daytime	97% - 105%	5%	3%
Vehicle Counts	Nighttime	97% - 115%	15%	3%
Vehicle Counts	Adverse Weather	97% - 115%	15%	3%

Parameter	Condition	Accuracy
Vehicle Classification	Daytime	90%
Vehicle Classification	Nighttime	90%
Vehicle Classification	Adverse Weather	90%

Parameter	Condition	Accuracy
Per-lane Occupancy	Daytime	90%
Per-lane Occupancy	Nighttime	90%
Per-lane Occupancy	Adverse Weather	90%

4. Testing

Develop and submit plans for post installation testing to the Engineer for consideration and approval. Ensure the plans test all functional requirements and the accuracy requirements stipulated in the specifications.

4.1 Post Installation Test Requirements

Utilize the following test procedures after the video detection system has been installed in its entirety. Commence no post-installation testing until all video detection systems in the project have been configured and/or calibrated to gather speed, volume, occupancy and/or presence detection. Including the accuracy testing requirements, at a minimum, provide the following on the test plan to be submitted and approved by the Engineer:

- Inspect all vehicle detection system field components to ensure proper installation and cable termination.
- Verify that field construction has been completed.

- Inspect the quality and tightness of ground and surge protector connections.
- Check power supply voltage and outputs and ensure device connections are as specified in the Plans and specifications.
- Verify that the installation of cables and connections between all detectors and field cabinets are as specified in the Plans and specifications.
- Demonstrate that each Video Detection System is fully operational and collecting the required data types at the specified interval.

7.3. CONSTRUCTION METHODS

A. Construction

1. Video Detection System Installation Requirements

1.1 General Installation Requirements

Arrange and conduct site surveys with Department personnel, and the system manufacturer's representative as necessary, to determine proper video camera sensor unit selection and placement. Provide the Department at least 3 working days' notice before conducting site surveys. The video detection system's manufacturer shall provide support both remotely and on-site for all phases of the installation.

Before beginning work at locations requiring video detection systems, furnish system software. Upon activation of detection zones, provide detector configuration files. Ensure that up-to-date detection configuration files are furnished for various detection zone configurations that may be required for construction phasing.

Place into operation video detection systems. Configure video detection systems to achieve required detection in designated zones. If requested, have a certified manufacturer's representative on site to supervise and assist with installation, set up, and testing of the system.

Install all video camera sensors, video detection system processors, output expansion modules, and associated enclosures and equipment per manufacturer recommendations. Make all necessary adjustments and modifications to the detection system prior to obtaining recommendation for system acceptance testing.

Installation, surge protection, and all cabling shall comply with manufacturer's recommendations, at a minimum, or as specified in the plans. All equipment, cables, and hardware must be part of an engineered system that is designed by the manufacturer to fully interoperate with all other system components and be fully protected from all surge potential. Connectors installed outside the cabinets and enclosures shall be manufacturer terminated and be corrosion resistant, weatherproof, and watertight. Use a UL listed cable that is ozone and UV resistant and weather resistant. Label cables with permanent cable labels at each end.

Relocate camera sensor units and reconfigure detection zones as necessary according to the plans for construction phases.

Furnish an as-built cabinet wiring diagram, identified by location, for each video detection system cabinet. Include all wiring, cabling, connections, and camera mounting height. Furnish an operation manual with programming instructions and a maintenance manual. Place all documentation in a weatherproof holder in the cabinet. Provide an additional copy of the documentation to the Engineer.

1.2 Camera Sensor Installation

Adjust the video camera sensor lens as recommended by the manufacturer, and as required to minimize vehicle occlusion. Aim the camera so that no part of the horizon is in the video image to protect it from the effects of the sun.

1.3 Cabinet Equipment

Install all video detection system equipment into a cabinet with the following equipment:

Wiring, Conductors and Terminal Blocks: Use stranded copper for all conductors, including those in jacketed cables, except for earth ground conductors, which may be solid copper. Neatly arrange all wiring, firmly lace or bundle it, and mechanically secure the wiring without the use of adhesive fasteners. Route and secure all wiring and cabling to avoid sharp edges and to avoid conflicts with other equipment or cabling. Route camera control wiring, and 120 VAC power wiring separately. Terminate all wiring on a terminal block, strip, busbar, or device clamp or lug; do not splice any wiring.

Label coaxial cables for video detection system cameras. Number all terminal blocks, terminal strips, circuit breakers, and busbar breakers and have each item and each terminal position numbered and named according to function. Labels shall be weather and wear resistant.

Protect all copper wiring and cabling entering the cabinet housing by surge protection devices. Terminate all wiring between cabinet devices and the transient surge protection devices, except for the video signal coaxial feed, on terminal strips. Use a minimum #16 AWG grounding wire for each surge protection device, or larger if recommended by the surge protection device manufacturer. Do not “daisy chain” with the grounding wires of other devices including other surge suppressors. Install grounding wires with the absolute minimum length possible between the surge protection device and the ground busbar. Label all surge protection devices on the mounting panel.

Furnish and install a surge suppressor for each video signal coaxial line. The coax surge protection device shall have a surge current rating of 10 kA. For each cabinet housing, include surge protection devices for the video detection system camera power lines installed on the terminal block.

All surge protection shall be furnished and installed by the Contractor to protect not only the cabinet processor, but the camera sensor itself from ground rise potential (i.e., surge up to the camera sensor).

B. Quality Acceptance/Testing

The acceptance testing of the vehicle detection systems shall consist of two phases: 1) post installation detection system testing, as outlined in these specifications and 2) burn-in period. Perform acceptance testing for all equipment, hardware, and work as provided under these specifications. Perform all testing in the presence of the Engineer. Submit all testing plans and documents to the Engineer during the submittal phase of the vehicle detection equipment.

1. Burn-in Period

1.1 General Requirements

Provide a 30-day burn-in period for all work and equipment included in the Contract and associated with the vehicle detection system. The burn-in period shall consist of the field operation of the specific vehicle detection system in a manner that is in full accordance with the requirements of the Plans and Specifications.

Conduct only one (1) burn-in period on the entire Contract for all vehicle detection devices. Burn-in tests of individual vehicle detection devices or groups of vehicle detection devices will not be acceptable. Commence with the burn-in period only after meeting all of the following requirements:

All work required in all Contract documents for the vehicle detection system project-wide has been completed and inspected by the Engineer.

Successfully complete the post-installation vehicle detection system testing.

Commence with the burn-in period upon written authorization by the Department to commence. Terminate the burn-in period 30 consecutive days thereafter unless an equipment malfunction occurs. Stop the burn-in period for the length of time any equipment is defective. After repairing the equipment so that it functions properly, resume the burn-in period at the point it was stopped.

Successful completion and acceptance of the burn-in period will be granted on the 31st day unless any equipment has malfunctioned. If any equipment has failed during the burn-in period, final acceptance will be withheld until all the equipment is functioning properly.

When one specific piece of equipment has malfunctioned more than three times during the 30-day burn-in period, replace that unit with a new unit at no cost to the Department. Multiple failures of detection devices in different locations shall be determined as a failure of the 30-day burn-in period. The Contractor shall investigate the detection system failure and shall give a full report to the Engineer. The Contractor shall replace the failed devices and shall restart the burn-in period at Day 1, once those devices have been replaced and retested.

1.2 Contractor Responsibilities

During the burn-in period, maintain all work under this Contract in accordance with the Plans and Specifications. Restore any work or equipment to proper operating condition within 8 hours after notification.

1.3 Department Responsibilities

Department responsibilities during the burn-in period will be as follows:

- Expedient notification of Contractor upon failure or malfunction of equipment.

1.4 Burn-in Period Acceptance

The Department will make burn-in period acceptance after satisfactory completion of the required burn-in period and based on a comprehensive field inspection of the complete vehicle detection system in accordance with the Specifications. Upon burn-in period acceptance but prior to Final Acceptance of the entire Contract, the Contractor is responsible for all maintenance of the vehicle detection system(s) installed or renovated in accordance with the specifications.

C. Contractor Warranty and Maintenance

Equipment provided under this specification shall be warranted by the manufacturer to be free from defects in materials and workmanship for a minimum of three (3) years from burn-in period acceptance.

The manufacturer and supplier's warranties shall be transferable to the agency or user that is responsible for maintenance and shall be continuous throughout their duration.

During the warranty period, the manufacturer shall repair or replace any faulty equipment without cost to the purchaser, NCDOT, or the maintaining agency for all incidentals to the repair or replacement, including but not limited to parts, labor, or shipping.

The manufacturer shall be responsible for providing firmware or software updates associated with the video detection system at no cost to NCDOT or the maintaining agency during the warranty period. Further, the manufacturer is also responsible for ensuring that any updates will not degrade the original functionality of the product warranted.

The manufacturer and/or supplier shall provide consultation to the Department or user that is responsible for maintenance as needed at no cost during the warranty period for operating questions or problems that arise.

D. Training

Provide at least eight (8) hours of training on the setup, configuration, operation, maintenance, and troubleshooting of the video detection system. Setup, configuration, and operation training should last a minimum of three (3) hours and must include instructions for programming, hands on training in programming detection zone, adjusting, and calibrating the detection system. Operation and maintenance training should last a minimum of five (5) hours and must include instructions on troubleshooting, maintenance, and operation for all detection system components. Arrange for training to be conducted by the manufacturer's representative at an approved site within the Division responsible for administration of the project. Thirty days before conducting training, submit a detailed course curriculum, draft manuals and materials, and resumes. Obtain approval of the submittal before conducting the training. At least one week before beginning training, provide two sets of complete documentation necessary to maintain and operate the system. Do not perform training until installation of the video detection systems is complete. Each class will have a maximum of ten (10) people. The contractor must provide a training notebook for each trainee and an electronic copy of the training to the Department.

7.4.MEASUREMENT AND PAYMENT

Actual number of site surveys, arranged, conducted, and accepted.

Actual number of luminaire arms for video detection systems furnished, installed, and accepted.

Actual number of video camera sensor assemblies furnished, installed, and accepted.

No measurement will be made of environmental enclosures, mounting assemblies and hardware, cables, connectors, interfaces, supplies, or other items necessary for proper operation of the video detection system as these items will be considered incidental to furnishing and installing video camera sensor assemblies.

Actual number of video detection system processor units furnished, installed, and accepted.

No measurement will be made of power supplies, power and communication wiring, necessary housing and rack assemblies, or configuration software as these items will be considered incidental to furnishing and installing video detection system processors.

Actual number of camera sensor units relocated with detection zones reconfigured, installed, and accepted.

Training for Video Detection is measured as a lump sum for all supplies, equipment, materials, handouts, travel, and subsistence necessary to conduct the training.

No measurement will be made of video detection system support, power and video cables, and trenching as these items will be considered incidental to furnishing and installing video detection systems.

Payment will be made under:

Site Surveys	Each
Luminaire Arms for Video Detection	Each
Video Camera Assembly	Each
Video Detection System Processor	Each
Relocate Camera Sensor Unit	Each
Training for Video Detection.....	Lump Sum

8. MICROWAVE VEHICLE DETECTOR – SINGLE ZONE

8.1. DESCRIPTION

Furnish and install a microwave vehicle detection unit and manufacturer recommended cables and hardware in accordance with the plans and specifications.

8.2. MATERIALS

Furnish material, equipment, and hardware under this section that is pre-approved on the ITS and Signals QPL.

Provide a detector for either side-fire or forward-fire configuration. Ensure the detector will detect vehicle in sunny, cloudy, rainy, snowy, and foggy weather conditions with self-tuning to auto-adjust in changing environmental conditions. Ensure the detector can operate from the voltage supplied by a NEMA and Type-170 traffic signal cabinet. Ensure the detector can provide detection calls to the traffic signal controller within a NEMA and Type-170 cabinet. Ensure the detector will put out a constant call in the event of a component failure or loss of power. Ensure the detector has

an operating temperature range of -20 to 150 degrees F. Ensure a water resistant housing for the detector.

For advance pulse detection, ensure the detector senses vehicles in motion at a range of 200 feet with an operating frequency of 10.525 GHz +/- 25MHz.

For stop bar presence detection, ensure the detector outputs a constant call while a vehicle is in the detection zone. Ensure the presence detection unit can cover a detection zone as shown on the plans and has an effective range of at least 75 feet from the detector unit to the aim point on the road surface.

For units without an integrated card rack interface, provide Form C output relay contacts rated a minimum of 3A, 24VDC.

If a laptop is used to adjust detector settings, ensure that software is licensed for use by the Department and by any other agency responsible for maintaining or operating the microwave detection system. Provide the Department with a license to duplicate and distribute the software as necessary for design and maintenance support.

8.3. CONSTRUCTION METHODS

Install the microwave vehicle detector in accordance with the manufacturer’s recommendations.

Monitor and maintain the detector unit during construction to ensure microwave vehicle detector is functioning properly and aimed for the detection zone shown in the plans. Refer to Subarticle 1700-3 (D) Maintenance and Repair of Materials of the *Standard Specifications* for failure to maintain the microwave detection system.

8.4. MEASUREMENT AND PAYMENT

Actual number of microwave vehicle detector units furnished, installed, and accepted.

No measurement will be made of cables or hardware, as these will be considered incidental to furnishing and installing microwave vehicle detectors.

Payment will be made under:

Microwave Vehicle Detector – Single Zone..... Each

9. MICROWAVE VEHICLE DETECTION SYSTEM - MULTIPLE DETECTION ZONES

9.1. DESCRIPTION

Design, furnish and install a microwave vehicle detection system with the manufacturer recommended cables and hardware in accordance to the plans and specifications. Ensure the detection system provides multiple detection zones.

9.2. MATERIALS

Provide design drawings showing design details and microwave sensor locations for review and acceptance before installation. Provide mounting height and location requirements for microwave sensor units on the design based on a site survey. Design microwave vehicle detection system with all necessary hardware. Indicate all necessary poles, spans, mast arms, luminaire arms, cables, microwave sensor mounting assemblies and hardware to achieve the required detection zones where Department owned poles are not adequate to locate the microwave sensor units. Do not design for the installation of poles in medians.

Obtain the Engineer’s approval before furnishing microwave vehicle detection system. The contractor is responsible for the final design of microwave vehicle detection system. Review and acceptance of the designs by the Department does not relieve the contractor from the responsibility

to provide fully functional systems and to ensure that the required detection zones can be provided. With the exception of contractor-furnished poles, mast arms, and luminaire arms, furnish material, equipment, and hardware under this section that is pre-approved on the ITS and Signals QPL. Submit and obtain Engineer's approval of shop drawings for any poles, mast arms, and luminaire arms provided by the contractor prior to ordering from manufacturer.

Provide a detector for either side-fire or forward-fire configuration. Ensure the detector will detect vehicles in sunny, cloudy, rainy, snowy, and foggy weather conditions. Ensure the detector can operate from the voltage supplied by a NEMA TS-1/TS-2 or Type 332 or 336 traffic signal cabinet. Ensure the detector can provide detection calls to the traffic signal controller within a NEMA TS-1/TS-2 or Type 332 or 336 cabinet. Ensure the detection system provides a constant call in the event of a component failure or loss of power. Ensure the detector has an operating temperature range of -30 to 165 degrees F and operates within the frequency range of 10 to 25 GHz. Ensure the detector is provided with a water-tight housing offering NEMA 4X protection and operates properly in up to 95% relative humidity, non-condensing.

Provide each detector unit to allow the placement of at least 8 detection zones with a minimum of 8 detection channel outputs. When the microwave vehicle detection system requires an integrated card rack interface(s), provide only enough interface cards to implement the vehicle detection shown on the signal plans. Provide a means acceptable to the Engineer to configure traffic lanes and detection zones. Provide each channel output with a programmable means to delay the output call upon activation of a detection zone that is adjustable in one second increments (maximum) over the range of 0 to 25 seconds. Provide each channel output with a programmable means to extend the output call that is adjustable in one second increments (maximum) over the range of 0 to 25 seconds. Ensure both delay and extend timing can be set for the same channel output.

For advance detection system, ensure the detector senses vehicles in motion at a range of 50 to 400 feet from the detector unit for forward-fire configuration and a range of 50 to 200 feet from the detector unit for side-fire configuration with an accuracy of 95% for both configurations. Ensure the advance detection system provides each channel output call of at least 100 ms in duration.

For stop bar presence detection system, ensure the detector outputs a constant call while a vehicle is in the detection zone and removes the call after all vehicles exit the detection zone. Ensure the presence detector unit can cover a detection zone as shown on the plans and has an effective range of 10 to 120 feet from the detector unit.

For units without an integrated card rack interface, provide Form C output relay contacts rated a minimum of 3A, 24VDC.

If a laptop is used to adjust detector settings, ensure that software is licensed for use by the Department and by any other agency responsible for maintaining or operating the microwave detection system. Provide the Department with a license to duplicate and distribute the software as necessary for design and maintenance support.

After initial detector configuration and installation, ensure routine adjustments or calibration are not needed to maintain acceptable performance.

9.3. CONSTRUCTION METHODS

Install the microwave vehicle detection system in accordance with the manufacturer's recommendations.

Monitor and maintain each detector unit during construction to ensure microwave vehicle detection system is functioning properly and aimed for the detection zone shown in the plans. Refer

to Subarticle 1700-3 (D) Maintenance and Repair of Materials of the *Standard Specifications* for failure to maintain the microwave detection system.

9.4. MEASUREMENT AND PAYMENT

Actual number of microwave vehicle detection systems – multiple zones furnished, installed, and accepted.

No measurement will be made of cables or hardware, as these will be considered incidental to furnishing and installing microwave vehicle detection systems.

Payment will be made under:

Microwave Vehicle Detection System – Multiple Zones Each

10. WIRELESS MAGNETIC SENSOR VEHICLE DETECTION SYSTEM

10.1. DESCRIPTION

Furnish a vehicle detection system that uses battery-powered magnetic field sensors for pavement installation that communicate traffic detection data by wireless communication to a transceiver for a local traffic signal cabinet. Ensure each sensor responds to the change in the earth’s local magnetic field resulting from the presence and passage of a vehicle. Ensure the system contains sensor(s), transceiver(s), and any other device(s) to provide detection data to a traffic signal controller.

10.2. MATERIALS

Furnish material, equipment, and hardware under this section that is pre-approved on the ITS and Signals QPL.

Provide magnetic sensors to detect vehicle traffic such as cars, trucks, and motorcycles. Ensure each sensor is sized for an installation into a 4-inch diameter by 3-inch deep hole. Ensure the sensor provides vehicle traffic data for volume and occupancy. Ensure the sensor holds a detection call when a vehicle is stopped in its detection field. Provide a sensor to simulate a detection zone of a 6’ x 6’ inductive loop. Provide a combination of sensors to simulate a detection zone of a 6’ x 40’ quadrupole inductive loop and a 6’ x 60’ quadrupole inductive loop. Ensure the sensors operate as specified by the intersection design plans.

Provide two-way wireless communication between the sensors and the transceiver devices. Ensure no disruption to the wireless communication when the transceiver devices are located on the side of the road surface. Ensure that the sensors can communicate with the transceiver devices for a minimum distance of 100 feet. Ensure all wireless communications within the system operate in an unlicensed frequency band and avoid interference with other devices operating in the unlicensed frequency band. Provide at least 16 frequency channels that are user-configurable.

Provide each sensor to transmit its detection data within 150 ms of a detected event. Ensure the sensor samples the earth’s magnetic field at a rate of 128 Hz or faster. Ensure that each sensor transmits a unique identifying code. Ensure that each sensor automatically recalibrates its threshold values in response to changes in the ambient magnetic field based on user-programmed criteria.

Furnish each sensor that is manufactured as a single housing module that conforms to NEMA Type 6P enclosure. Ensure that the components of the sensor are fully encapsulated within the housing to prevent moisture from degrading the components. Ensure the sensor operates at temperatures from -37 degrees F to 176 degrees F. Provide battery-power with an average life expectancy of 10 years when the sensor is operating under normal traffic conditions.

Provide a clear injection molded clamshell style case made of polypropylene for protecting the sensor in the roadway. Ensure case protects the sensor from sealant material. Ensure the case holds the sensor in place and is form-fitting to ensure cured sealant does not collapse when exposed to traffic loads.

Furnish the transceiver to provide detection data to the traffic signal cabinet and ensure the traffic signal controller receives each sensor detection call. Ensure the traffic signal controller receives both presence mode and pulse mode detection calls.

Provide indications inside the traffic signal cabinet to display each channel detection status and fault condition. Provide a means to select presence mode and pulse mode for each channel. Provide user-selectable sensitivity levels for vehicle detection. Furnish equipment to operate in Type 332 and 336S traffic signal cabinets.

Provide software for installation and use on personal computers to upload and download configuration data to each sensor. Ensure application software is compatible with Windows 7 operating system. Ensure software does not require administrative permissions to load and operate. Ensure the software can retrieve and store detection data from the sensors. Ensure the software on the personal computer transmits data from the personal computer to each sensor through the transceiver by wireless communication. Also, provide any update to the firmware in each sensor by wireless communication. Provide a license to the Department to allow the duplication of the personal computer software as needed to design, install and maintain these systems.

10.3. CONSTRUCTION METHODS

Install the wireless magnetic sensor vehicle detector system in accordance with the manufacturer's recommendations. Enclose the wireless magnetic sensor in a molded clamshell style case before installation into the roadway. When installing each sensor into the hole, ensure epoxy sufficiently covers the sensor in the road surface.

Arrange and conduct site surveys with the system manufacturer's representative and Department personnel to determine proper sensor and transceiver selection and placement. Provide the Department at least 3 working days notice before conducting site surveys. The Engineer will approve final locations of sensors, transceivers and any necessary repeaters.

Install the transceiver in such a manner that avoids conflicts with other utilities and as specified in the manufacturer's recommendations. Secure the transceiver mounting hardware to the pole and route the cabling such that no strain is placed on connectors.

Before beginning work at locations that require a wireless magnetic sensor vehicle detector system, furnish system software. Upon activation of the system, provide detector configuration files.

Place system into operation. Configure wireless magnetic sensor vehicle detector system to achieve required detection in designated areas. Have a certified manufacturer's representative on site to supervise and assist with installation, set up, and testing of the system.

Install the necessary processing and communications equipment in the signal controller cabinet. Make all necessary modifications to install equipment in cabinet. Ensure the traffic signal controller receives each sensor detection call.

Place a copy of all manufacturer equipment specifications and instruction and maintenance manuals in the equipment cabinet.

Provide at least 4 hours of training on the set up, operation, troubleshooting, and maintenance of the wireless magnetic sensor vehicle detector system to a maximum of ten Department personnel. Arrange for training to be conducted by the manufacturer's representative at an approved site within

the Division responsible for administration of the project. Thirty days before conducting training submit a detailed course curriculum, draft manuals and materials, and resumes. Obtain approval of the submittal before conducting the training. At least one week before beginning training, provide three sets of complete documentation necessary to maintain and operate the system. Do not perform training until installation of the wireless magnetic sensor vehicle detector system is complete.

10.4. MEASUREMENT AND PAYMENT

Actual number of wireless magnetic sensor vehicle detector systems furnished, installed, and accepted.

No measurement will be made of cables or hardware, as these will be considered incidental to furnishing and installing wireless magnetic sensor vehicle detector system.

Payment will be made under:

Wireless Magnetic Sensor Vehicle Detector System.....Each

11. GPS UNIT - OASIS

11.1. DESCRIPTION

Furnish and install a GPS unit in the traffic signal cabinet for time synchronization in accordance with the plans and specifications. Comply with the provisions of Section 1700 of the Standard Specifications for Roads and Structures.

11.2. MATERIALS

Provide a GPS unit and antenna for time synchronization that supports the Trimble Standard Interface Protocol (TSIP) and is compatible with Econolite Oasis local controller software.

11.3. CONSTRUCTION METHODS

Mount GPS antenna on pole adjacent to cabinet at a minimum height of 10’ ensuring that the antenna can acquire enough satellites to be accurate. Use 3/4” rigid metallic conduit with appropriate fittings for mounting the antenna and running the interface cable. Provide GPS antenna interface cable that is not more than 50’ in length. Provide a drip loop in the cable before it enters the conduit. Ensure the cable entry point into the conduit is waterproof. If a pole is not within 30’ of the cabinet, the GPS antenna may be mounted to the top of the cabinet, while ensuring that the connection point into the cabinet is waterproof. Provide and install an RS-422 to RS-232 converter for connection between the GPS antenna and the 2070 controller unit.

11.4. MEASUREMENT AND PAYMENT

Actual number of GPS units furnished, installed, and accepted.

No measurement will be made for interface cables, RS-422 to RS-232 converter, and connectors, as these are considered incidental to furnishing and installing the GPS unit assemblies.

Payment will be made under:

GPS Unit.....Each

12. GPS UNIT - GENERIC

12.1. DESCRIPTION

Furnish and install a GPS unit in the traffic signal cabinet for time synchronization in accordance with the plans and specifications. Comply with the provisions of Section 1700 of the Standard Specifications for Roads and Structures.

12.2. MATERIALS

Provide a GPS unit and antenna for time synchronization that supports the NMEA 0183 standard, version 2.1 or later, as defined by the National Marine Electronics Association. The GPS unit shall support the following NMEA standard sentences: RMC, GGA, GSA, GSV, GLL and ZDA. The unit shall have an update interval of at least once per minute. Ensure the unit operates properly over a temperature range of -34.6° F to +165.2° F.

For traffic signal installations, the GPS unit shall communicate to the 2070 controller unit via an RS-232 serial data port on the controller. Provide any necessary data converters (for example: RS-422 to RS-232 converter) to achieve communications to the controller unit from the GPS.

12.3. CONSTRUCTION METHODS

Mount the GPS antenna on the pole adjacent to the cabinet at a minimum height of 10’ ensuring that the antenna can acquire enough satellites to be accurate. Provide conduit with appropriate fittings for mounting the antenna and running the interface cable. Provide a GPS antenna interface cable that is not more than 50’ in length. Provide a drip loop in the cable before it enters the conduit. Ensure the cable entry point into the conduit is waterproof. If a pole is not within 30’ of the cabinet, the GPS antenna may be mounted to the top of the cabinet, while ensuring that the connection point into the cabinet is waterproof. Provide and install a data converter for connection between the GPS antenna and the 2070 controller unit as necessary.

12.4. MEASUREMENT AND PAYMENT

Actual number of GPS units furnished, installed, and accepted.

No measurement will be made for interface cables, conduit, data converters, and connectors, as these are considered incidental to furnishing and installing the GPS unit assemblies.

Payment will be made under:

GPS UnitEach

13. TEMPORARY STATIONARY TRAFFIC SIGNAL SYSTEM

13.1. DESCRIPTION

Furnish, install, place in operation, repair, maintain, reposition, and remove the temporary stationary traffic signal system. Comply with the provisions of Section 1700 of the 2024 Standard Specifications for Roads and Structures and the generic Project Special Provisions for Signals and Intelligent Transportation Systems located at:

<http://www.ncdot.org/doh/preconstruct/traffic/ITSS/>

13.2. MATERIALS

Provide a complete temporary traffic signal system including but not limited to 12-inch vehicle signal heads, signal cable, messenger cable, wood poles, guy assemblies, inductive detection loops, microwave vehicle detectors, lead-in cable, trenching, riser assemblies, required signs, detector units, 2070 controller with 336 pole mounted cabinet, and appropriate pavement markings.

All traffic signal equipment must be in compliance with the plans provided by NCDOT (**plans will be provided upon request from the contractor**), the project special provisions, and the 2024 Standard Specifications for Roads and Structures.

13.3. CONSTRUCTION METHODS

NCDOT will provide the temporary stationary traffic signal plans **30 days** after **written request** is submitted to the Engineer. Plan requests shall consist of the following information: a drawing

showing the exact location of the stopbars (include Stations), speed limit posted during operation, percent grade on each approach, times and duration of operation.

Ensure that the signal meets the physical display and operational requirements of conventional traffic signals as specified in PART IV of the *Manual on Uniform Traffic Control Devices (MUTCD)* and the *North Carolina Supplement to the MUTCD* in effect on the date of advertisement.

Perform all maintenance operations required by the manufacturer. Have properly skilled and trained maintenance personnel available to maintain the system in good working order and to perform all emergency and preventive maintenance as recommended by the equipment manufacturer.

Furnish the Engineer with the name, office telephone number, cellular (mobile) telephone number, and pager number of the supervisory employee who will be responsible for maintenance and repair of equipment during all hours.

In the event that the signal becomes inoperative, be prepared at all times to revert to a flagging operation or suspend all construction activities requiring the use of the temporary stationary traffic signal system until the signal is restored to proper operation.

Remove signals within two weeks of completion of work requiring the use of temporary stationary traffic signal system.

13.4. MEASUREMENT AND PAYMENT

Actual number of **days** that each Temporary Stationary Traffic Signal System is operated.

No measurement will be made for operation, relocation, maintenance, removal of each signal system, or use of flaggers during repair periods as these will be considered incidental to furnishing, installing, and operating the Temporary Traffic Signal System.

Any Temporary Stationary Traffic Signal System used for less than one hour will be considered incidental to the operation that required the use of such signal.

No measurement will be made for signal controller, communication cable, messenger cable, wireless communication, inductive loop sawcut, loop emulator detection system, machine vision detection system, microwave detection system, detector channel/unit, detector lead-in cable, trenching, vehicle signal heads, signal head support assemblies, signal cable, and traffic signal software as these will be considered incidental to furnishing, installing, and operating the Temporary Traffic Signal System.

Refer to “Temporary Traffic Signal System Alternates” Special Provision for payment.

14. PORTABLE TRAFFIC SIGNAL SYSTEM

14.1. DESCRIPTION

Furnish, install, place in operation, repair, maintain, relocate, and remove portable traffic signal systems. Comply with the provisions of Section 1700 of the 2024 Standard Specifications for Roads and Structures.

14.2. MATERIALS

Furnish material, equipment, and hardware under this section that is pre-approved on the ITS and Signals QPL.

Provide a complete portable traffic signal system that is totally mobile and capable of being relocated as traffic conditions demand. Design the system for operation both with and without an

external power source. Furnish two signal control trailers with two vehicle signal heads per trailer and one operator unit for each portable traffic signal system. Furnish transmitters, generators, batteries, controls, back-up systems and all other components necessary to operate the system.

Ensure each system meets the physical display and operational requirements of conventional traffic signals as specified in PART IV of the Manual on Uniform Traffic Control Devices (MUTCD) and the North Carolina Supplement to the MUTCD in effect on the date of advertisement.

Used equipment will be acceptable if the equipment is in good working condition. Contractor retains ownership of the portable traffic signal systems.

Provide yellow 12-inch aluminum or polycarbonate vehicle signal heads with 10-inch tunnel visors, backplates and Light Emitting Diode (LED) modules. Provide aluminum signal heads and backplates listed on the Department's Qualified Products List (QPL) for traffic signal equipment. Provide polycarbonate signal heads and visors that comply with the provisions pertaining to Signal Heads within these Project Special Provisions with the following exceptions:

Fabricate signal head housings, end caps, and visors from virgin polycarbonate material. Provide U.V. stabilized polycarbonate plastic with a minimum thickness of 0.1 ± 0.01 inches that is highway yellow (Federal Standard 595C, Color Chip 13538). Ensure the color is incorporated into the plastic material before molding the signal head housings and end caps. Ensure the plastic formulation provides the following physical properties in the assembly (tests may be performed on separately molded specimens):

Test	Required	Method
Specific Gravity	1.17 minimum	ASTM D 792
Vicat Softening Temperature, °F	305-325	ASTM D 1525
Brittleness Temperature, °F	Below -200	ASTM D 746
Flammability	Self-extinguishing	ASTM D 635
Tensile Strength, yield, PSI	8500 minimum	ASTM D 638
Elongation at yield, %	5.5-8.5	ASTM D 638
Shear, strength, yield, PSI	5500 minimum	ASTM D 732
Izod impact strength, ft-lb/in [notched, 1/8 inch]	15 minimum	ASTM D 256
Fatigue strength, PSI at 2.5 mm cycles	950 minimum	ASTM D 671

To minimize signal head movement due to wind, mount top and bottom of signal heads to the signal head supports.

Provide 120V AC powered LED modules listed on the QPL, or provide 12V DC powered LED modules that meet the ITE VTCSH Part 2: Light Emitting Diode (LED) Vehicle Signal Modules (Interim Purchase Specification) with the exception of paragraphs 5.2, 5.3, 5.7, and testing associated with 120V AC. Ensure DC powered LED modules operate with input power between 9V DC and 15V DC.

Provide trailers that have durable paint in highway orange, Federal Standard 595C Color Chip ID # 12473 with a minimum paint thickness of 2.5 mils.

Provide trailers with a 12-volt trailer lighting system complying with Federal Motor Carrier Safety Regulations 393, safety chains, and a 2-inch ball hitch. When provided, locate generators, fuel tanks, batteries and electronic controls in protective housings that are provided with locks to restrict access.

Design the trailer assembly and signal supports to withstand an 80 MPH wind load with the signal supports raised in the operating position. Provide independent certification from a registered Professional Engineer that the assembly meets this 80 MPH wind load requirement. Provide a reliable hydraulic, electric or manual means for raising and lowering the signal support members. Provide screw-type stabilizing and leveling devices with a self-leveling foot to support the unit in the operating position on slopes 1V:3H or flatter when detached from the transporting vehicle.

During manual operation, ensure the system provides a means of informing the operator of signal indications, such as a light on the back of each signal head that illuminates when the signal displays a red indication.

Design the portable traffic signal system to perform without interruption during the time it is in operation.

Where a traffic actuated system is required, provide a system control unit that is capable of pre-timed operation, traffic actuated operation, a variable green time interval dependent upon vehicle actuations, and programmable yellow clearance and red clearance intervals. Furnish all sensors to monitor vehicle demands for vehicle actuation per the Project Special Provisions and Section 1098 of the Standard Specifications.

Design the systems to be fail-safe. Ensure the system monitors the following conditions: lack of green, yellow, and red signal indication voltage, total loss of indication on any approach, presence of multiple signal indications on any approach, conflicting green/yellow signal indications, and low power condition. In the event any of these conditions are detected, immediately begin flashing operation of red indications in all directions.

Provide either hard-wired, microwave, or radio controlled type communications for pre-timed and traffic actuated portable traffic signal systems. In the event a loss of communication is detected, immediately begin flashing operation of red indications in all directions.

Ensure systems that use wireless communication links continuously monitor and verify proper transmission and reception of data used to monitor and control each signal head. Ensure ambient mobile or other radio transmissions or adverse weather conditions do not affect the system. Encode signal transmissions digitally to protect radio transmissions from interference. Do not violate FCC regulations and ensure radio frequencies are appropriate for portable signal equipment applications.

Upon detecting a malfunction, ensure all signals go to a flashing red condition and the operator is notified by a reliable means approved by the Engineer. Provide a battery back-up system for generator and direct current powered signal systems to power the warning means and "flashing red" condition. Provide a back-up system with a 72-hour minimum reserve.

Ensure the system meets the Environmental Standards for traffic signals in accordance with NEMA TS-1, Section 2.

14.3. CONSTRUCTION METHODS

Do not use portable traffic signal systems in a work area with intersecting streets or driveways, unless directed by the Engineer.

Do not install portable traffic signal within 300 feet of at-grade railroad crossing.

During automatic operation, ensure the motorist has an unobstructed view of opposing traffic.

Ensure the distance between signal units does not exceed 500 feet unless otherwise shown on the plans or directed by the Engineer. If modification to the distance between signal units is required after the units are positioned, relocate the signals or the system and make the necessary timing revisions only as directed by the Engineer.

Submit a traffic signal timing plan to the Engineer for approval a minimum of two weeks prior to installation. Include the following items in the plan: distance between stop bars, speed limit to be posted during operation, each approach grade, recommended yellow change interval, recommended red clearance interval, recommended minimum and maximum green intervals. Make timing changes to approved signal timing plan only as authorized by the Engineer. Keep a written record of all timing changes.

Allow only trained operators to set up and operate the system. Provide an experienced operator at all times for each portable traffic signal system during periods of manual operation. Do not violate yellow change and red clearance intervals during periods of manual operation. During manual operation, ensure the operator has an unobstructed view of the motorists and all signal head units. Locate the operator as close to the center of the operation as possible.

Perform all maintenance operations required by the system manufacturer including periodic cleaning of the systems. Ensure properly skilled and trained maintenance personnel are available to maintain the system in good working order and to perform all emergency and preventive maintenance as recommended by the system manufacturer.

Furnish the Engineer with the name, office telephone number, cellular (mobile) telephone number, and pager number of the supervisory employee who will be responsible for maintenance and repair of equipment during all hours.

For all failures, malfunctions, or damage to this equipment, begin necessary repairs within four hours of notification. Complete repairs within eight hours of notification. Comply with Section 150 of the Standard Specifications for maintenance of traffic flow. The inability to contact the supervisory employee or prearranged alternate will not extend repair time requirements.

In the event that the system becomes inoperative, be prepared at all times to revert to flagging operations or suspend all construction activities requiring the use of the portable traffic signal system until the system is restored to proper operation. Implement flagging operations as shown on 2024 Roadway Standard Drawing No. 1101.02 Sheet 1 (Closure of one lane of a Two-lane, Two-way Highway).

When not in operation, remove signal heads from the view of traffic or cover signal heads with burlap bags or bags made of non-ripping material specifically designed for covering signal heads. Do not use trash bags of any type. Remove, cover, fold, or turn all inappropriate signs so that they are not readable by oncoming traffic.

14.4. MEASUREMENT AND PAYMENT

Actual number of portable traffic signal systems furnished, installed, operated, removed, and accepted.

No measurement will be made for operation, relocation, maintenance, removal of each system, or use of flaggers during repair periods as these will be considered incidental to furnishing, installing, and operating the portable traffic signal systems.

No measurement will be made for signal controller, communication cable, messenger cable, wireless communication, inductive loop sawcut, loop emulator detection system, machine vision detection system, microwave detection system, detector channel/unit, detector lead-in cable, trenching, vehicle signal heads, signal head support assemblies, signal cable, and traffic signal

software as these will be considered incidental to furnishing, installing, and operating the portable traffic signal systems.

Payment will be made under:

Portable Traffic Signal System (actuated)	Each
Portable Traffic Signal System (pre-timed)	Each

15. METAL POLE SUPPORTS

15.1. METAL POLES

A. General:

Furnish and install metal poles, grounding systems, and all necessary hardware. Work covered under this special provision includes requirements for design, fabrication, and installation of standard and custom/site-specific designed metal pole supports and associated foundations.

Comply with applicable sections of the *2024 STANDARD SPECIFICATIONS FOR ROADS & STRUCTURES*, hereinafter referred to as the *Standard Specifications*. Provide designs of completed assemblies with hardware equaling or exceeding *AASHTO LRFD Specifications for Structural Supports for Highway Signs, Luminaires and Traffic Signals* 1st Edition, 2015 (hereinafter called 1st Edition AASHTO), including the latest interim specifications. Provide assemblies with a round or near-round (18 sides or more) cross-section, or a multi-sided cross section with no less than six sides. The sides may be straight, convex, or concave.

For bid purposes, pole heights shown on plans are estimated from available data. Prior to furnishing metal poles, use field measurements and adjusted cross-sections to determine whether pole heights will meet required clearances. If pole heights do not meet required clearances, the Contractor should immediately notify the Engineer of the required revised pole heights.

Standard Drawings for Metal Poles are available that supplement these project special provisions. The drawings are located on the Department’s website:

<https://connect.ncdot.gov/resources/safety/pages/ITS-Design-Resources.aspx>

Comply with article 1098-1(B) of the *Standard Specifications* for submittal requirements. Furnish shop drawings for approval. Provide copies of detailed shop drawings for each type of structure as summarized below. Ensure shop drawings include material specifications for each component. Ensure shop drawings identify welds by type and size on the detail drawing only, not in table format. **Do not release structures for fabrication until shop drawings have been approved by NCDOT.** Ensure shop drawings contain an itemized bill of materials for all structural components and associated connecting hardware.

Comply with article 1098-1(A) of the *Standard Specifications* for Qualified Products List (QPL) submittals. All shop drawings must include project location description, signal or asset inventory number(s) and project number or work order number.

Summary of information required for metal pole review submittal:

Item	Electronic Submittal	Comments / Special Instructions
Sealed, Approved Signal or ITS Plan/Loading Diagram	1 set	All structure design information needs to reflect the latest approved Signal or ITS plans

Custom Pole Shop Drawings	1 set	Submit drawings on 11" x 17" format media. Show NCDOT signal or asset inventory number(s), Contractor's name and relevant revision number in the title block. All drawings must have a <u>unique drawing number</u> for each project.
Standard Strain Pole Shop Drawings (from the QPL)	1 set	Submit drawings on 11" x 17" format media. Show NCDOT signal inventory number(s), Contractor's name and relevant revision number in the title block. All drawings must have a <u>unique drawing number</u> for each project.
Structure Calculations	1 set	Not required for Standard QPL Poles
Standard Strain Pole Foundation Drawings	1 set	Submit drawings on 11" x 17" format media. Submit a completed Standard Foundation Selection form for each pole using foundation table on Metal Pole Drawing M8.
Custom Foundation Drawings	1 set	Submit drawings on 11" x 17" format media. Show NCDOT signal or asset inventory number(s), Contractor's name and relevant revision number in the title block. All drawings must have a <u>unique drawing number</u> for each project. If QPL Poles are used, include the corresponding QPL pole shop drawings with this submittal.
Foundation Calculations	1 set	Submit copies of LPILE input, output, and pile tip deflection graph per Section titled Drilled Pier Foundations for Metal Poles of this specification for each foundation. Not required for Standard Strain Poles (from the QPL)
Soil Boring Logs and Report	1 set	Report shall include a location plan and a soil classification report including soil capacity, water level, hammer efficiency, soil bearing pressure, soil density, etc. for each pole.

NOTE – All shop drawings and custom foundation design drawings must be sealed by a Professional Engineer licensed in the state of North Carolina. All geotechnical information must be sealed by either a Professional Engineer or Geologist licensed in the state of North Carolina. Include a title block and revision block on the shop drawings and foundation drawings showing the NCDOT signal or asset inventory number(s).

Shop drawings and foundation drawings may be submitted together or separately for approval. However, shop drawings must be approved before foundations can be reviewed. Foundation designs will be returned without review if the associated shop drawing has not been approved. Boring reports shall include the following: Engineer's summary, boring location maps, soil classification per AASHTO Classification System, hammer efficiency, and Metal Pole Standard Foundation Selection Form. Incomplete submittals will be returned without review. The Reviewer has the right to request additional analysis and copies of the calculations to expedite the approval process.

B. Materials:

Fabricate metal pole from coil or plate steel that meet the requirements of ASTM A 572 Gr 55 or ASTM A 595 Grade A tubes. For structural steel shapes, plates, and bars use, as a minimum, ASTM A572 Gr 50, AASHTO M270 Gr 50, ASTM A709 Gr 50, or an approved equivalent. Provide pole shafts of round or near round (18 sides or more) cross-section, or multi-sided tubular cross-section with no less than six sides, having a uniform linear taper of 0.14 in/ft. Construct shafts from one piece of single-ply plate or coil. For anchor base fabrication, conform to the applicable bolt pattern and orientation as shown on Metal Pole Standard Drawing Sheet M2.

Use the submerged arc process, or other NCDOT previously approved process suitable for shafts, to continuously weld pole shafts along their entire length. Finish the longitudinal seam weld flush with the outside contour of the base metal. Ensure shaft has no circumferential welds except at the lower end joining the shaft to the pole base. Use full penetration groove welds with backing ring for all tube-to-transverse-plate connections in accordance with 1st Edition AASHTO. Provide welding that conforms to Article 1072-18 of the *Standard Specifications*. No field welding on any part of the pole will be permitted unless approved by a qualified Engineer.

After fabrication, hot-dip galvanize steel poles and all assembly components in accordance with section 1076-3 of the *Standard Specifications*. Design structural assemblies with weep holes large enough and properly located to drain molten zinc during the galvanization process. Galvanize hardware in accordance with section 1076-4 of the *Standard Specifications*. Ensure threaded material is brushed and retapped as necessary after galvanizing. Perform repair of damaged galvanizing in accordance with section 1076-7 of the *Standard Specifications*. Ensure all hardware is galvanized steel or stainless steel. The Contractor is responsible for ensuring the Designer/Fabricator specifies connecting hardware and/or materials that prevent a dissimilar metal corrosive reaction.

Ensure each anchor rod is 2-inch minimum diameter and 60-inch length. Provide 10-inch minimum thread projection at the top of the rod, and 8-inch minimum at the bottom of the rod. Use anchor rod assembly and drilled pier foundation materials complying with SP09_R005, hereinafter referred to as *Foundations and Anchor Rod Assemblies for Metal Poles*.

Ensure anchor bolt hole diameters are 1/4-inch larger than the anchor bolt diameters in the base plate.

Provide a circular anchor bolt lock plate securing the anchor bolts at the embedded end with two (2) washers and two (2) nuts. Provide a base plate template matching the bolt circle diameter of the anchor bolt lock plate. Construct plates and templates from 1/4-inch minimum thick steel with a minimum width of 4 inches. Hot-dip galvanizing is not required for both plates.

Provide four (4) heavy hex nuts and four (4) flat washers for each anchor bolt. For nuts, use AASHTO M291 grade 2H, DH, or DH3 or equivalent material. For flat washers, use AASHTO M293 or equivalent material. Ensure anchor bolts have required diameters, lengths, and positions, and will develop strengths comparable to their respective poles.

For each pole, provide a grounding lug with a 1/2-inch minimum thread diameter, coarse thread stud and nut that will accommodate #4 AWG ground wire. Ensure the lug is electrically bonded to the pole and is conveniently located inside the pole at the hand hole.

Provide a removable pole cap with stainless steel attachment screws for the top of each pole. Ensure cap is cast aluminum conforming to Aluminum Association Alloy 356.0F. Furnish cap attached to the pole with a sturdy stainless-steel chain that is long enough to permit cap to hang clear of the pole-top opening when cap is removed.

Where required by the plans, furnish couplings 42 inches above bottom of the pole base for mounting of pedestrian pushbuttons. Provide mounting points consisting of 1½-inch internally threaded half-couplings complying with the NEC, mounted within the poles. Ensure that couplings are essentially flush with the outside surfaces of the poles and are installed before any required hot-dip galvanizing. Provide a threaded plug in each mounting point. Ensure the surface of the plug is essentially flush with the outer end of the mounting point when installed and has a recessed slot that will accommodate a ½ “drive standard socket wrench.

Metal poles may be erected and fully loaded after concrete has attained a minimum allowable compressive strength of 3,000 psi.

Connect poles to grounding electrodes and bond them to the electrical service grounding electrodes.

When field drilling is necessary for wire or cable entrances into the pole, comply with the following requirements:

- Do not drill holes within 2 inches of any welds.
- Do not drill any holes larger than 3 inches in diameter without checking with the ITS & Signals Structure Engineers.
- Avoid drilling multiple holes along the same cross section of tube shafts.
- Install rubber grommets in all field drilled holes that wire, or cable will directly enter unless holes are drilled for installation of weather heads or couplings.
- Treat the inside of the drilled holes and repair all galvanized surfaces in accordance with Section 1076-7 of the latest edition of the *Standard Specification prior to installing grommets, caps, or plugs*.
- Cap or plug any existing field drilled holes that are no longer used with rubber, aluminum, or stainless-steel hole plugs.

When street lighting is installed on metal signal structures, isolate the conductors feeding the luminaires inside the pole shaft using liquid tight flexible metal conduit (Type LFMC), liquid tight flexible nonmetallic conduit (Type LFNC), high density polyethylene conduit (Type HDPE), or approved equivalent. All conductors supplying power for luminaires must run through an external disconnect prior to entrance into the structure. In accordance with the National Electrical Code (NEC) Article 230.2(E), provide identification of the electrical source provider for the luminaire feeder circuit with contact information on a permanent label located in the pole hand hole near the feeder circuit raceway.

Install a ¼-inch thick plate for a concrete foundation tag to include the following information: concrete grade, depth, diameter, and reinforcement sizes of the installed foundation. Install galvanized wire mesh to cover gap between the base plate and top of foundation for debris and pest control. Refer to standard drawing M7 for further details.

Immediately notify the Engineer of any structural deficiency that becomes apparent in any assembly, or member of any assembly, because of the design requirements imposed by these specifications, the plans, or the typical drawings.

C. Design:

Unless otherwise specified, design all metal pole support structures using the following 1st Edition AASHTO specifications:

- Use 700-Year MRI and 10-Year MRI wind pressure maps developed from 3-second gust speeds, as provided in Section 3.8.

- Ensure metal pole support structures include natural wind gust loading and truck-induced gust loading for fatigue design, as provided in Sections 11.7.1.2 and 11.7.1.3, respectively. Designs need not consider periodic galloping forces.
- Assume 11.2 mph natural wind gust speed in North Carolina. For natural wind fatigue stress calculations, utilize a drag coefficient (C_d) based on the yearly mean wind velocity of 11.2 mph.
- When selecting Fatigue Importance Factors, utilize Fatigue Importance Category II, as provided for in Table 11.6-1, unless otherwise specified.
- Calculate all forces using applicable equations from Section 5. The Maximum allowable force ratio for all metal pole support designs is 0.9.
- Conform to Sections 10.4.2 and 11.8 for deflection requirements. For CCTV and MVD support structures, ensure maximum deflection at top of pole does not exceed 2.0 percent of pole height.
- Assume the combined minimum weight of a messenger cable bundle (including messenger cable, signal cable and detector lead-in cables) is 1.3 lbs/ft. Assume the combined minimum diameter of the cable bundle is 1.3 inches.
- All CCTV and MVD poles shall meet the compact section limits per section 5.7.2 along with Table 5.7.2-1. Minimum thickness of CCTV and MVD pole shafts shall be ¼-inch.
- All CCTV and MVD poles shall use full-penetration groove weld tube-to-transverse plate connection with backing ring. Refer to Metal Pole Standard Drawing Sheet M9 for details. Fillet-welded tube-to-transverse-plate connections are not permitted.

Unless otherwise specified by special loading criteria, the following computed surface area for ice load on signal heads shall be used:

- 3-section, 12-inch, Surface area: 26.0 ft²
- 4-section, 12-inch, Surface area: 32.0 ft²
- 5-section, 12-inch, Surface area: 42.0 ft²

Design a base plate for each pole. The minimum base plate thickness for all poles is determined by the following criteria:

Case 1 Circular or rectangular solid base plate with the upright pole welded to the top surface of base plate with full penetration butt weld, where no stiffeners are provided. A base plate with a small center hole, which is less than 1/3 of the upright diameter, and located concentrically with the upright pole, may be considered as a solid base plate.

The magnitude of bending moment in the base plate, induced by the anchoring force of each anchor bolt is $M = (P \times D_1) / 2$, where

M = bending moment at the critical section of the base plate induced by one (1) anchor bolt

P = anchoring force of each anchor bolt

D_1 = horizontal distance between the anchor bolt center and the outer face of the upright, or the difference between the bolt circle radius and the outside radius of the upright

Locate the critical section at the face of the anchor bolt and perpendicular to the bolt circle radius. The overlapped part of two (2) adjacent critical sections is considered ineffective.

Case 2 Circular or rectangular base plate with the upright pole socketed into and attached to the base plate with two (2) lines of fillet weld, and where no stiffeners are provided, or any base plate with a center hole that is larger in diameter than 1/3 of the upright diameter.

The magnitude of bending moment induced by the anchoring force of each anchor bolt is $M = P \times D_2$,

where P = anchoring force of each anchor bolt

D_2 = horizontal distance between the face of the upright and the face of the anchor bolt nut

Locate the critical section at the face of the anchor bolt top nut and perpendicular to the radius of the bolt circle. The overlapped part of two (2) adjacent critical sections is considered ineffective.

If the base plate thickness calculated for Case 2 is less than Case 1, use the thickness calculated for Case 1.

The following additional requirements apply concerning pole base plates.

- Ensure that whichever case governs as defined above, the anchor bolt diameter is set to match the base plate thickness. If the minimum diameter required for the anchor bolt exceeds the thickness required for the base plate, set the base plate thickness equal to the required bolt diameter.
- For all metal poles, use a full penetration groove weld with a backing ring to connect the pole upright component to the base. Refer to Metal Pole Standard Drawing Sheet M3 or M4.

The Professional Engineer is wholly responsible for the design of all poles. Review and acceptance of these designs by the Department does not relieve the said Professional Engineer of his or her responsibility.

D. Strain Poles:

Refer to Metal Pole Standard Drawing Sheets M2 and M3 for fabrication details.

Provide two (2) messenger cable (span wire) clamps and associated hardware for attachment of messenger cable. Ensure diameter of the clamp is appropriate to its location on the pole and is appropriately designed for adjustment from 1'-6" below the top, down to 6'-6" below the top of the pole. Do not attach more than one (1) support cable to a messenger cable clamp.

Provide a minimum of three (3) 2-inch holes equipped with an associated coupling and weatherhead on the messenger cable load side of the pole to accommodate passage of signal cables from inside the pole. Provide galvanized threaded plugs for all unused couplings at pole entrance points. Refer to Metal Pole Standard Drawing Sheet M3 for fabrication details.

Provide designs with a 6" x 12" hand hole with reinforcing frame for each pole.

Provide a terminal compartment with cover and screws in each pole encompassing the hand hole and containing a 12-terminal barrier type terminal block. Provide two (2) terminal screws with a removable shorting bar between them for each termination. Furnish terminal compartment covers attached to the pole by a sturdy chain or cable approved by the Engineer. Ensure chain or cable is long enough to permit cover to hang clear of the compartment opening when cover is removed and is strong enough to prevent vandalism. Ensure chain or cable will not interfere with service to cables in the pole base.

Have poles permanently stamped above the hand holes with the identification tag details as shown on Metal Pole Standard Drawing Sheets M2 and M3.

Provide grounding lug(s) in the approximate vicinity of the messenger cable clamp for bonding and grounding messenger cable. Lugs must accept #4 AWG wire to bond messenger cables to the pole in order to provide an effective ground fault circuit path. Refer to Metal Pole Standard Drawing Sheet M6 for construction details.

Install metal poles, hardware, and fittings as shown on the manufacturer’s installation drawings. Ensure the installed pole, when fully loaded, is within 1 degree 40 minutes (1°40') of vertical. Install poles with the manufacturer’s recommended “rake.” Where required, use threaded leveling nuts to establish rake.

E. Mast Arm Poles:

Refer to Metal Pole Standard Drawing Sheets M2 through M5 for fabrication details.

Fabricate metal arm shaft from coil or plate steel that meet the requirements of ASTM A 595 Grade A tubes. Provide arm shafts of round or near round (18 sides or more) cross-section, or multi-sided tubular cross-section with no less than six sides, having a uniform linear taper of 0.14 in/ft. Construct shafts from one piece of single-ply plate or coil, eliminating circumferential weld splices.

Use the submerged arc process, or other NCDOT previously approved process suitable for arm shafts, to continuously weld arm shafts along their entire length. The longitudinal seam weld shall be finished flush to the outside contour of the base metal. Ensure arm shaft has no circumferential welds except at the lower end joining the shaft to the arm flange plate. Use full penetration groove welds with backing ring for all tube-to-transverse-plate connections in accordance with 1st Edition AASHTO. Provide welding that conforms to Article 1072-18 of the *Standard Specifications*, except no field welding on any part of the arm shaft will be permitted unless approved by a qualified Engineer.

After fabrication, hot-dip galvanize steel arm shafts and all assembly components per section 1076 of the *Standard Specifications*. Design arm shafts with weep holes large enough and properly located to drain molten zinc during the galvanization process. Provide hot-dip galvanizing on steel arm shafts that meets or exceeds ASTM Standard A-123, AASHTO M111, or an approved equivalent. Perform repair of damaged galvanizing that complies with the following *Standard Specifications* article:

Repair of GalvanizingArticle 1076-7

Ensure metal arm shafts permit cables to be installed inside arm shafts. For holes in arm shafts used to accommodate cables, provide full-circumference grommets. Wire access holes for arm flange plates should be deburred, non-grommeted, and oversized to fit around 4-inch diameter grommeted wire access holes for shaft flange plates.

Provide a minimum of four (4) 1-1/2” diameter high strength bolts for connection between arm plate and pole plate. Increase number of bolts to a minimum of six (6) 1-1/2” diameter high strength bolts when arm lengths are greater than 50’-0” long.

Provide designs with a 6” x 12” hand hole with reinforcing frame for each pole.

Provide a terminal compartment with cover and screws in each pole encompassing the hand hole and containing a 12-terminal barrier type terminal block. Provide two (2) terminal screws with a removable shorting bar between them for each termination. Furnish terminal compartment covers attached to the pole by a sturdy chain or cable approved by the Engineer. Ensure chain or cable is long enough to permit cover to hang clear of the compartment opening when cover is removed and is strong enough to prevent vandalism. Ensure chain or cable will not interfere with service to cables in the pole base.

Have poles permanently stamped above the hand holes with the identification tag details as shown on Metal Pole Standard Drawing Sheets M2 and M4.

Provide a removable end cap with stainless steel attachment screws for the end of each mast arm. Ensure cap is cast aluminum conforming to Aluminum Association Alloy 356.0F. Furnish cap attached to arm with a sturdy chain or cable approved by the Engineer. Ensure chain or cable is long enough to permit cap to hang clear of arm end opening when cap is removed.

Provide pole flange plates and associated gussets and fittings for attachment of required mast arms. As part of each mast arm attachment, provide a cable passage hole in pole to allow passage of cables from pole to arm. Provide a grommeted 4-inch diameter cable passage hole on the shaft side of the connection to allow passage of cables from pole to arm.

Furnish all arm plates and necessary attachment hardware, including bolts and brackets.

Provide two (2) extra bolts for each arm.

Provide arms with weatherproof connections for attaching to the pole shaft.

Provide hardware that is galvanized steel, stainless steel, or corrosive-resistant aluminum.

Install metal poles, hardware, and fittings as shown on the manufacturer's installation drawings. Ensure the installed pole, when fully loaded, is within 1 degree 40 minutes ($1^{\circ}40'$) of vertical. Install poles with the manufacturer's recommended "rake." Where required, use threaded leveling nuts to establish rake.

Install horizontal-type arms with a manufactured rise preventing arm from deflecting below arm attachment height.

Ensure maximum angular rotation of the top of mast arm pole does not exceed 1 degree 40 minutes ($1^{\circ}40'$). Ensure allowable mast arm deflection does not exceed that allowed per 1st Edition AASHTO. For all load combination limit states specified under Section 3 of 1st Edition AASHTO, restrict tip of fully loaded arm from going below arm attachment point with the pole.

F. CCTV and MVD Poles:

Refer to Metal Pole Standard Drawing Sheets M2, M3 and M9 for fabrication details.

Furnish hand hole covers attached to the pole by a sturdy chain or cable approved by the Engineer. Ensure chain or cable is long enough to permit cover to hang clear of the compartment opening when cover is removed and is strong enough to prevent vandalism. Ensure chain or cable will not interfere with service to cables in the pole shaft.

Furnish and install the required Air Terminal & Lightning Protection System as described in the "Air Terminal & Lightning Protection System" Project Special Provisions and as referenced in the following Typical Details:

- CCTV and MVD Camera Installation for Metal Pole with Aerial Electrical Service
- CCTV and MVD Camera Installation for Metal Pole with Underground Electrical Service

Have poles permanently stamped above the hand holes with the identification tag details as shown on Metal Pole Standard Drawing Sheets M2, M3 and M9.

Provide a 2-inch hole equipped with an associated coupling and weather head approximately 5 feet below top of pole to accommodate passage of CCTV and MVD cables from inside pole to CCTV and MVD camera.

Provide a 2-inch hole equipped with an associated coupling and conduit fittings/bodies approximately 18 inches above base of pole to accommodate passage of CCTV and MVD cables

from CCTV and MVD cabinet to inside of pole. Refer to Metal Pole Standard Drawing Sheet M3 for fabrication details.

Install CCTV and MVD metal poles, hardware, and fittings as shown on the manufacturer's installation drawings. Ensure the installed pole, when fully loaded, is within 0.5 degrees of vertical. Where required, use threaded leveling nuts to establish rake.

Comply with the following requirements for CCTV and MVD Pole Anchor Bolts and Base Plates:

- Poles up to 40'-0" in length, provide a minimum of four (4) 2-inch diameter anchor bolts, and a minimum 2-inch-thick circular base plate. Provide anchor bolts of Grade 55 ksi, and base plate of Grade 50 ksi.
- Poles greater than 40'-0" and up to 100'-0" in length, provide a minimum of eight (8) 2-inch diameter anchor bolts, and a minimum 2-inch-thick circular base plate. Provide anchor bolts of Grade 55 ksi, and base plate of Grade 50 ksi.

Obtain the Structural Engineer's approval for deviations from these requirements, prior to shop drawing(s) submission.

G. Luminaire Arms:

Comply with the following for Steel Luminaire Arms:

- Furnish tapered tube or standard weight black steel pipe conforming to ASTM A 53-90a, Type E or Type S, Grade B or an approved equivalent.
- Provide welding conforming to Article 1072-18 of the Standard Specifications, except no field welding on any part of the will be permitted unless approved by a qualified Engineer.
- Hot-dip galvanize the structure in accordance with AASHTO M 111 or an approved equivalent, once all fabricating, cutting, punching, and welding are completed.
- In accordance with National Electrical Code (NEC) Article 230.2(E), provide identification of the electrical source provider for the luminaire feeder circuit with contact information on a permanent label located in the pole hand hole near the feeder circuit raceway.

15.2. DRILLED PIER FOUNDATIONS FOR METAL POLES

Analysis procedures and formulas shall be based on AASHTO 1st Edition, latest ACI-318 code and the *Drilled Shafts: Construction Procedures and Design Methods* FHWA-NHI-10-016 manual. Design methods based on engineering publications or research papers must have prior approval from NCDOT. The Department reserves the right to accept or reject any method used for the analysis.

Ensure deflection at top of foundation does not exceed 1 inch for worst-case (Service Limit State) lateral load.

Use LPILE Plus V6.0 or later for lateral analysis. Submit inputs, results and corresponding graphs with the design calculations.

Calculate skin friction using the α -method for cohesive soils and the β -method for cohesion-less soils (**Broms method will not be accepted**). Detailed descriptions of the " α " and " β " methods can be found in *FHWA-NHI-10-016*.

Omit first 2.5 feet for cohesive soils when calculating skin friction.

Assume a hammer efficiency of 0.70 unless value is provided.

All CCTV and MVD pole drilled shafts shall be a minimum of 4'-0" diameter. Refer to Standard Drawing Nos. M7 and M8.

Design custom foundations to carry maximum capacity of each metal pole. For standard case strain poles with custom design, use actual shear, axial and moment reactions from the Standard Strain Pole Foundation Selection Table shown on Standard Drawing No. M8.

When poor soil conditions are encountered, which could create an excessively large foundation design, consideration may be given to allow an exemption to the maximum capacity design. The Contractor must gain approval from the Engineer before reducing a foundation's capacity. On projects where poor soil is known to be present, the Contractor should have foundation designs approved before releasing poles for fabrication.

Have the Contractor notify the Engineer if the proposed foundation is to be installed on a slope other than 8H: 1V or flatter.

A. Description:

Furnish and install foundations for NCDOT metal poles with all necessary hardware in accordance with the plans and specifications.

Metal Pole Standards have been developed and implemented by NCDOT for use at signalized intersections in North Carolina. If the plans call for a standard strain pole, then a standard foundation may be selected from the plans. However, the Contractor is not required to use a standard foundation. If the Contractor chooses to design a non-standard site-specific foundation for a standard strain pole or if the plans call for a non-standard site-specific pole, design the foundation to conform to the applicable provisions in the NCDOT Metal Pole Standard Drawings and Section B4 (Non-Standard Foundation Design) below. If non-standard site-specific foundations are designed for standard QPL approved strain poles, the foundation designer must use the design moment specified by load case on Metal Pole Standard Drawing Sheet M8. Failure to conform to this requirement will be grounds for rejection of the design.

If the Contractor chooses to design a non-standard foundation for a standard strain pole and the soil test results indicate a standard foundation is feasible for the site, the Contractor will be paid the cost of the standard foundation. Any additional cost associated with a non-standard site-specific foundation including additional materials, labor and equipment will be considered incidental to the cost of the standard foundation. All costs for the non-standard foundation design will be considered incidental to the cost of the standard foundation.

B. Soil Test and Foundation Determination:

1. General:

Drilled piers are reinforced concrete sections, cast-in-place against in situ, undisturbed material. Drilled piers are of straight shaft type and vertical.

2. Soil Test:

Perform a soil test at each proposed metal pole location. Complete all required fill placement and excavation at each pole location to finished grade before drilling each boring. Soil tests performed that are not in compliance with this requirement may be rejected and will not be paid. Drill one boring to a depth of 26 feet within a 25-foot radius of each proposed foundation.

Perform standard penetration tests (SPT) in accordance with ASTM D 1586 at depths of 1, 2.5, 5, 7.5, 10, 15, 20 and 26 feet. Discontinue the boring if one of the following occurs:

- A total of 100 blows have been applied in any two consecutive 6-inch intervals.
- A total of 50 blows have been applied with < 3-inch penetration.

Describe each pole location along the project corridor in a manner that is easily discernible to both the Contractor's Designer and NCDOT Reviewers. If the pole is at an intersection, label the boring the "Intersection of (Route or SR #), (Street Name) and (Route or SR #), (Street Name), _____ County, Signal or Asset Inventory No. _____". Label borings with "B- N, S, E, W, NE, NW, SE or SW" corresponding to the quadrant location within the intersection.

If the pole location is located between intersections, provide a coordinate location and offset, or milepost number and offset. Pole numbers should be made available to the Drill Contractor. Include pole numbers in the boring label if they are available. If they are not available, ensure the boring labels can be cross-referenced to corresponding pole numbers. For each boring, submit a legible (hand-written or typed) boring log signed and sealed by a licensed Geologist or Professional Engineer registered in North Carolina. Include on each boring the SPT blow counts and N-values at each depth, depth of the boring, hammer efficiency, depth of water table and a general description of the soil types encountered using the AASHTO Classification System.

Borings that cannot be easily correlated to their specific pole location will be returned to the Contractor for clarification; or if approved by the Engineer, the foundation may be designed using the worst-case soil condition obtained as part of this project.

3. Standard Foundation Determination:

Use the following method for determining the Design N-value:

$$N_{AVG} = \frac{N_{@1'} + N_{@2.5'} + \dots + N_{@Deepest\ Boring\ Depth}}{\text{Total Number of } N \text{ values}}$$

$$Y = (N_{@1'})^2 + (N_{@2.5'})^2 + \dots + (N_{@Deepest\ Boring\ Depth})^2$$

$$Z = N_{@1'} + N_{@2.5'} + \dots + N_{@Deepest\ Boring\ Depth}$$

$$N_{STD\ DEV} = \sqrt{\left(\frac{(\text{Total Number of } N \text{ values} \times Y) - Z^2}{(\text{Total Number of } N \text{ values}) \times (\text{Total Number of } N \text{ values} - 1)} \right)}$$

Design N-value equals lesser of the following two conditions:

$$N_{AVG} - (N_{STD\ DEV} \times 0.45)$$

OR

$$\text{Average of First Four (4) } N \text{ values} = \frac{N_{@1'} + N_{@2.5'} + N_{@5'} + N_{@7.5'}}{4}$$

Note: If less than four (4) N-values are obtained because of criteria listed in Section 2 above, use average of N-values collected for second condition. Do not include the N-value at the deepest boring depth for above calculations if the boring is discontinued at or before the required boring depth because of criteria listed in Section 2 above. Use N-value of zero (0) for weight of hammer or weight of rod. If N-value is greater than fifty (50), reduce N-value to fifty (50) for calculations.

If standard NCDOT strain poles are shown on the plans and the Contractor chooses to use standard foundations, determine a drilled pier length, “L,” for each signal pole from the Standard Strain Pole Foundations Chart (sheet M8) based on the Design N-value and the predominant soil type. For each standard pole location, submit a completed “Metal Pole Standard Foundation Selection Form” signed by the Contractor’s representative. Signature on form is for verification purposes only. Include the Design N-value calculation and resulting drilled pier length, “L,” on each form.

If non-standard site-specific poles are shown on the plans, submit completed boring logs collected in accordance with Section 2 (Soil Test) along with pole loading diagrams from the plans to the Contractor-selected pole Fabricator to assist in the pole and foundation design.

If one of the following occurs, the Standard Foundations Chart shown on the plans may not be used and a non-standard foundation may be required. In such case, contact the Engineer.

- The Design N-value is less than four (4).
- The drilled pier length, “L”, determined from the Standard Foundations Chart, is greater than the depth of the corresponding boring.

In the case where a standard foundation cannot be used, the Department will be responsible for the additional cost of the non-standard foundation.

Foundation designs are based on level ground around the traffic signal pole. If the slope around the edge of the drilled pier is steeper than 8:1 (H:V) or the proposed foundation will be less than 10 feet from the top of an embankment slope, the Contractor is responsible for providing slope information to the foundation Designer and to the Engineer so it can be considered in the design.

The “Metal Pole Standard Foundation Selection Form” may be found at:

<https://connect.ncdot.gov/resources/safety/Pages/ITS-Design-Resources.aspx>

If assistance is needed, contact the Engineer.

4. Non-Standard Foundation Design:

Design non-standard foundations based upon site-specific soil test information collected in accordance with Section 2 (Soil Test). Design drilled piers for side resistance in accordance with Section 10.8 of the *2014 AASHTO LRFD Bridge Design Specifications, 7th Edition*. Use computer software LPILE version-6.0 or later manufactured by Ensoft, Inc. to analyze drilled piers. Use computer software gINT V8i or later manufactured by Bentley Systems, Inc. with the current NCDOT gINT library and data template to produce SPT boring logs. Provide a drilled pier foundation for each pole with a length and diameter resulting in horizontal lateral movement less than 1 inch at top of the pier, and horizontal rotational movement less than 1 inch at the edge of pier. Contact the Engineer for pole loading diagrams of standard poles used for non-standard foundation designs. Submit non-standard foundation designs including drawings, calculations, and soil boring logs to the Engineer for review and approval before construction.

C. Drilled Pier Construction:

Construct drilled pier foundation and Install anchor rod assemblies in accordance with the *Foundations and Anchor Rod Assemblies for Metal Poles* Standard Special Provision SP09-R005 located at:

<https://connect.ncdot.gov/resources/Specifications/Pages/2024-Specifications-and-Special-Provisions.aspx>

15.3. METAL POLE REMOVALS**A. Description:**

Remove and dispose of existing metal support poles, and remove and dispose of existing foundations, associated anchor bolts, electrical wires and connections.

B. Construction Methods:**5. Foundations:**

Remove and promptly dispose of the metal support pole foundations including reinforcing steel, electrical wires, and anchor bolts to a minimum depth of 2 feet below the finished ground elevation. At the Contractor's option, remove the complete foundation.

6. Metal Poles:

Consult Division Traffic Services regarding ownership of poles. If the Division chooses to maintain these structures in their inventory for future use, permanently mark the pole with the signal inventory number, asset inventory number or some identifying information that identifies where the pole came from

Remove the metal support poles, and promptly transport the metal support poles from the project. Use methods to remove the metal support poles and attached equipment that will not result in damage to other portions of the project or facility. Repair damages that are a result of the Contractor's actions at no additional cost to the Department.

Transport and properly dispose of the materials.

Backfill and compact disturbed areas to match the finished ground elevation. Seed unpaved areas.

Use methods to remove the foundations that will not result in damage to other portions of the project or facility. Repair damages that are a result of the Contractor's actions at no cost to the Department.

15.4. POLE NUMBERING SYSTEM**A. New Poles**

Attach an identification tag to each pole shaft section as shown on Metal Pole Standard Sheet M2 "Typical Fabrication Details for All Metal Poles."

B. Reused Poles

Do not remove the original identification tag(s) from the pole shaft sections. Add a new identification tag based on the new location for any reused poles.

15.5. REUSED POLE SHAFTS

Provide shop drawings along with new foundation designs for review and approval prior to furnishing and/or installing any reused metal poles. Use the same requirements as specified for new materials as stated above in these Special Provision.

15.6. REUSED MAST ARM SHAFTS

For reused pole shaft and mast arm combinations, it is preferable to use the original shafts and arms that were used together at the time of original installation.

15.7. MEASUREMENT AND PAYMENT

Actual number of metal strain signal poles (without regard to height or load capacity) furnished, installed and accepted.

Actual number of reused metal strain signal poles (without regard to height or load capacity) installed and accepted.

Actual number of designs for metal strain poles furnished and accepted.

Actual number of metal poles with single mast arms furnished, installed, and accepted.

Actual number of metal poles with dual mast arms furnished, installed, and accepted.

Actual number of reused metal poles with single mast arms installed and accepted.

Actual number of reused metal poles with dual mast arms installed and accepted.

Actual number of designs for mast arms with metal poles furnished and accepted.

Actual number of metal signal pole foundations removed and disposed.

Actual number of metal signal poles removed and disposed.

Actual number of CCTV or MVD Metal Poles furnished, installed and accepted.

Actual number of soil tests with SPT borings drilled furnished and accepted.

Actual volume of concrete poured in cubic yards of drilled pier foundation furnished, installed and accepted.

No measurement will be made for foundation designs prepared with metal pole designs, as these will be considered incidental to designing Traffic Signal , CCTV or MVD support structures.

Payment will be made under:

Metal Strain Signal Pole	Each
Install Reused Metal Strain Signal Pole.....	Each
Metal Strain Pole Design	Each
Metal Pole with Single Mast Arm	Each
Metal Pole with Dual Mast Arm.....	Each
Install Reused Metal Pole with Single Mast Arm.....	Each
Install Reused Metal Pole with Dual Mast Arm	Each
Mast Arm with Metal Pole Design	Each
Metal Pole Foundation Removal	Each
Metal Pole Removal.....	Each
CCTV or MVD Metal Pole.....	Each
Soil Test	Each
Drilled Pier Foundation.....	Cubic Yard

16. PROTECTIVE COATING FOR METAL POLES

16.1. General

This special provision is intended for use as an additional treatment to metal traffic signal structures installed in areas where maintaining an aesthetic appearance is important and specified in the project documents. The provision contains all of the requirements necessary to accomplish this additional treatment to galvanized steel traffic signal structures fabricated by a steel manufacturer using their local powder coating/paint facility and includes the material and shop certification requirements. The provision also contains pay items for protective coating treatment to aluminum

signal and pedestrian pedestals that are Standard Specification items (See Section 1743 and associated Standard Drawings). These aluminum pedestals are on the Qualified Product List (QPL), and as such would not likely be powder coated at the same facility and thus not bound by the material certification requirements in this provision. In this case, the pedestal supplier should comply with Type 6 – Supplier’s Certification as defined in Section 106-3 of the Standard Specification.

16.2. Description

Protective coating for metal poles is a supplemental durable color coating that is applied to galvanized steel and aluminum traffic signal structures. Powder Coating is the preferred supplemental protective coating process for coating galvanized steel and aluminum structures. However, for the purposes of this special provision, an Acrylic Primer and topcoat paint system is included as an acceptable alternative when protective color coating is required.

Provide protective coating over galvanization for all steel poles including all necessary hardware in accordance with the plans and specifications.

16.3. Materials

With the exception of aluminum components, furnish all metal poles with galvanic protection along with a tough and durable application of protective coating. Aluminum components shall have a durable powder coating application. Galvanization is not required for aluminum components.

Furnish pole caps that have a low gloss powder finish applied over a hot-dipped galvanized surface. Comply with the applicable provisions of Section 442-10 and 442-13 of the 2024 Standard Specifications.

Ensure the selected color for protective coating has been verified and approved by the Engineer prior to fabrication.

16.4. Facility Approval

The Department maintains an approved producer/supplier listing for various facility types associated with this work, which include powder applicator (PA), structural steel galvanizer (SSG), and structural steel shop coating facilities (SCF). A complete list of approved facilities can be found at the following weblink: <https://apps.ncdot.gov/vendor/ApprovedProducts/Producer.aspx> Approve the coating shop facility prior to the application of any coating process. Submit all new facility requests, procedures, and documents electronically to:

Materials and Test
1801 Blue Ridge Road
Raleigh, NC 27607
Attn: Manufactured Products Engineer

Powder Coating Shop Approval

- A) Submit a quality control procedure that the company has established to ensure a quality and durable coating. The quality control procedure shall contain at a minimum the following:
- Qualified / Certified personnel to manage the QC Program and to conduct Quality Control tests
 - Qualified / certified coaters

- Source and type of powder
 - How the powder will be stored
 - Powder application facility (heated or unheated)
 - Surface pre-treatment
 - Surface preparation including profile
 - Application methods
 - Curing conditions (conventional or infrared)
 - Curing Temperature
 - Adhesion & Holiday Detection
 - Repair Procedure
 - Storage and protection of coated items
 - Shipping and handling (packing, protection, and wrapping)
- B) Submit a powder certification from the manufacturer
- C) Submit the following to the Chemical Testing Engineer a minimum of four weeks prior to coating application.
1. Two test panels of ASTM A36 steel, ¼ or greater in thickness measuring 8 inches by 11 inches using the proposed color of the final coat; a powder coated over galvanized test panel and a powder coated over un-galvanized test panel.
 2. In addition, provide two (2) samples of the same or comparable material and thickness as production pieces. Ensure production piece replicas do not exceed twelve inches (12”) in length and width nor 50 pounds in weight.
 3. Submit all test panels with inspection reports and records according to *Standard Specifications*, Section 442, Section 1072, Section 1076, and Section 1080.
 4. Acceptance of the panels is determined by meeting the requirements of ASTM D-4541 of 800 psi for both galvanized and un-galvanized and production piece test panels.
 5. Send all panels to:
Materials and Tests Unit
1801 Blue Ridge Road
Raleigh, NC 27607
Attn: Chemical Lab

16.5. POWDER COATING

A. Galvanizing

Galvanize steel products in accordance with Section 1076 of the Standard Specifications. Ensure the fabricator or designated representative(s) that is supplying the components to be galvanized communicates with the galvanizer to indicate that the galvanized pieces will be powder coated to avoid water or chromate quenching.

B. Surface Preparation

Comply with manufacturer's recommended surface coating specifications, Steel Structure Painting Council (SSPC) specifications and applicable articles of Section 442 (Painting Steel

Structures) of the Standard Specifications. Ensure that surface preparations and treatments are performed and meet the requirements of the above referenced specifications.

Some pole components, specifically steel plates $\frac{3}{4}$ inches or more in thickness, may need blast cleaning prior to structure assembly to remove impurities and non-metallic foreign materials. Mechanically remove all weld flux after structure is assembled

Degrease and prepare steel structure for zinc coating after assembly using full immersion baths and pickling processes in heat controlled caustic and acid solutions. Rinse and clean structure to remove caustic or acid solutions by immersion in a circulating fresh water bath. Immerse structure in a heat controlled concentrated zinc ammonium chloride flux solution and air dry as a final prep before hot-dip galvanization.

Ensure that the surface preparation is no less than specified by the powder manufacturer's recommendations. Prepare all components to be coated in accordance with SSPC SP-2 (Hand Tool Cleaning) and/or SSPC SP-3 (Power Tool Cleaning). Remove all drainage spikes, high spots, protrusions or other surface defects using hand or power tools. Do not remove the galvanization below the limits set forth in AASHTO M111.

Remove grease, oils, moisture, scale, rust or any other foreign matter prior to powder coating to ensure ideal adhesion and coating performance. Prepare and coat the galvanized surface as soon as possible after the galvanization process.

C. Powder Coating Application and Curing

Prepare galvanized finish for powder coating by brush blasting in accordance with SSPC-SP7. Ensure all threaded components of the structure are protected from damage during blasting process.

Use thermosetting powder resin that meets 5A or 5B classifications of ASTM D3359. Apply powder coating electrostatically. Follow manufacturer's recommended preheating requirements. Ensure the topcoat finish is applied uniformly to all surfaces with a dry film thickness of between 3.0 to 5.0 mils. Cure the topcoat by heating the structure to manufacturer recommended temperatures at the duration required to ensure complete and uniform bond.

D. Quality Control

Ensure the applicator provides all test reports and documentation and inspects all coated material as outlined in the Standard Specifications, Section 442, Section 1072, Section 1076, and Section 1080. Ensure the quality control inspection is kept separate from the production functions.

E. Storage, Shipping, and Handling

Store all powder coated material inside or as directed by the Engineer.

Protect the product from incurring damage during all shipping, handling, and storing activities. Do not store the product directly on the ground or in areas where water may pool; the Engineer determines the effectiveness of all storage, shipping and handling methods.

F. Repair of Powder Coated Material

Repair all damage to the coating by the original method of application as outlined in the coating facility's repair procedure. Ensure all repair areas meet the original requirements for adhesion as stated in this Project Special Provision.

Photograph, document, and report all damages upon delivery to the project site prior to unloading. Provide documented damage notifications to the Engineer or to their authorized representative so the application firm can be notified. The Engineer has the authority to accept or reject the material as outlined in the Standard Specifications.

Submit to the Engineer a repair procedure for damaged coatings which occur during storage, transporting, handling and or installation. Utilize a liquid paint approved by the Department, compatible with the powder applied product. Ensure all repair areas demonstrate an adhesion rating of 400 psi in accordance with ASTM D-4541. Obtain Engineer's acceptance of the final finish.

16.6. ACRYLIC PRIMER AND TOPCOAT PAINT SYSTEM

A. Description

Follow NCDOT procedures for Powder Coating over Galvanizing. Provide an Acrylic Primer and topcoat when a substitute for powder coating is necessary.

Provide supplemental coating for all mast arms with metal signal poles and all necessary hardware for the signalized intersection in accordance with the Structural Steel Shop Coatings Program, NCDOT Standard specifications – sections 442 and 1080, as contained herein, and as shown on the plans. The Structural Steel Shop Coatings Program can be found at the following link: <https://connect.ncdot.gov/resources/Materials/MaterialsResources/Structural%20Steel%20Shop%20Coatings%20Program.pdf>

Ensure all painting work for new structures, except field touch-up and bolt painting is performed in the shop.

Coatings Shop Approval

Use only NCDOT approved shop coating facilities meeting the requirements outlined in the current edition of the Structural Steel Shop Coatings Program. This program is available on the Materials and Tests website. [Structural Steel Shop Coatings Program.pdf \(ncdot.gov\)](#)

Provide shop certification in accordance with the Structural Steel Shop Coatings Program (Shop facilities that are currently certified and in good standing with the American Institute Steel Construction (AISC) / Sophisticated Paint Endorsement (SPE) and/or the Society of Protective Coatings (SSPC) Qualification Procedure Three (QP-3).

B. Surface Preparation

Ensure all surface preparation is not less than that specified by the paint manufacturer's recommendations.

Clean galvanized surfaces to be painted with a 2,500-psi pressure washer. Allow surfaces to dry completely before beginning surface preparation.

Ensure all components to be coated are prepared in accordance with SSPC SP2 (Hand Tool Cleaning and or SSPC SP-3 (Power Tool Cleaning). Smooth high spots and rough edges, such as metal drip lines, of galvanized surfaces in accordance with ASTM D6386. Do not remove the galvanization below the limits set forth in AASHTO M111.

Perform abrasive sweep blasting in accordance with ASTM D6386. Refer to this section for a description of the abrasive blast material to be used. Use a material and technique capable of stripping action to remove corrosion products and to provide a rough surface profile while leaving base zinc layers intact.

Blow down all blasted surfaces with clean compressed air to provide a clean, dry surface.

Ensure all surfaces are free of visible zinc oxides or zinc hydroxides.

C. Materials

Use an approved/qualified waterborne paint meeting the requirements of NCDOT Standard specification section 1080. Do not apply paint until each batch has been tested by the Department. Provide color as specified in the contract documents.

Ensure all paint used on this contract is produced by the same manufacturer.

D. Painting

Apply paint in accordance with the requirements of the Structural Steel Shop Coatings Program, Section 442 and Section 1080 of the *Standard Specifications* as modified herein.

**System for Paint over Galvanize
Acrylic Primer and Topcoats**

Coat	Material	Mils Dry/Wet Film	Mils Dry/Wet Film
		Thickness	Thickness
		Minimum	Maximum
Primer	1080-9 White	3.0 DFT	5.0 DFT
Stripe	1080-9 *	4.0 WFT	7.0 WFT
Topcoat	1080-9 *	2.0 DFT	4.0 DFT
Total		5.0 DFT	9.0 DFT

***Ensure the selected color for protective coating has been verified and approved by the Engineer prior to fabrication.**

The time between blast and coating application shall be in accordance with ASTM D6386 time requirements. In no case shall the prepared surface extend beyond 8 hours.

Mask off and do not paint all data plates and faying surfaces prior to application.

Spray apply all coatings except for the stripe coat. Brush apply the stripe coat to all plate edges, welds, bolt holes and bolts prior to applying the finish coat.

E. Curing

Follow manufacturer recommendations.

F. Inspection

Quality Control shall conduct the required quality control tests as outlined in the Structural Steel Shop Coatings Program and report the minimum information required by the appropriate ASTM test methods. At a minimum, quality control forms shall be on company letterhead with logo that provides a daily inspection report form equivalent to the information required on the M&T-611 Form. The M&T-611 Form can be found in the Structural Steel Shop Coatings Program. Dry Film Thickness (DFT) measurements shall be obtained on all coating layers, including the galvanized layer and shall incorporate the use of a Type 2 gauge as defined in SSPC PA-2.

Ensure all material is of a uniform appearance free of runs, drips, and sags.

G. Handling

Do not handle, ship, or erect coated members until paint is thoroughly dry.

Protect all shipping and handling either from the coating facility to project site and or storage site to area(s) to construction location from incurring damage to product. Wood blocks and nylon slings are recommended for securing, loading, hoisting or storing members.

H. Repair of Damaged Coating

Repair damage occurring to the galvanized portion of the coating during shipment or installation in accordance with Articles 1076-7 and 1080-7 of the *Standard Specifications*. Repair damage occurring to the painted portion of the coating during shipment or installation by applying 4.0-7.0 wet mils of topcoat with a brush or roller and feather or taper this to be level with the surrounding areas.

16.7. MEASUREMENT AND PAYMENT

Actual number of strain poles with protective coating applied furnished, installed, and accepted.

Actual number of single mast arm poles with protective coating applied furnished, installed, and accepted.

Actual number of dual mast arm poles with protective coating applied furnished, installed, and accepted.

Actual number of signal TYPE I pedestals with protective coating applied furnished, installed, and accepted.

Actual number of signal TYPE II pedestals with protective coating applied furnished, installed, and accepted.

Actual number of signal TYPE III pedestals with protective coating applied furnished, installed, and accepted.

Payment will be made under:

Protective Coating for Strain Pole (_____)	Each
Protective Coating for Single Mast Arm Pole (_____)	Each
Protective Coating for Dual Mast Arm Pole (_____)	Each
Protective Coating for TYPE I Pushbutton Post (_____)	Each
Protective Coating for TYPE II Signal Pedestal (_____)	Each
Protective Coating for TYPE III Signal Pedestal (_____)	Each

17. RECTANGULAR RAPID FLASHING BEACON SOLAR POWERED DISPLAY AND CONTROLLER ASSEMBLY

17.1. DESCRIPTION

Provide rectangular rapid flashing beacon (RRFB) that is solar powered and pedestrian activated. Ensure the RRFB consist of two rapidly flashing rectangular-shaped yellow indications, solar panel, battery, controller assembly and all necessary hardware. Ensure multiple RRFB units at a given crosswalk are synchronized.

Ensure the RRFB meets the physical display and operational requirements in the interim approval for RRFB by the Federal Highway Administration; see requirements at https://mutcd.fhwa.dot.gov/resources/interim_approval/ia21/ia21.pdf.

Ensure the RRFB meets the full requirements as noted in the subsequent Official Interpretations issued by the Federal Highway Administration.

17.2. MATERIALS

Comply with Section 1094 of the 2024 Standard Specifications for Roads and Structures for ground mounted sign supports. Unless otherwise shown on the plans, Three Pound Steel U-Channel Posts shall be used for mounting the rectangular rapid flashing beacon assembly.

Provide two rapid flashing yellow indications that are aligned horizontally in a single housing with a space between both indications of a minimum of 7" from inside edge of one indication to inside edge of the other indication. Ensure each indication is rectangular-shaped and has minimum dimensions of 5" wide by 2" high. Provide a Light Emitting Diode (LED) array for each indication. Provide Independent Laboratory Certification and test results for each indication facing motorists as evidence that the light intensity meets the Class 1 requirements for of the Society of Automotive Engineers (SAE) standard J595 (Directional Flashing Optical Warning Devices for Authorized Emergency, Maintenance, and Service Vehicles) dated November 2008. Provide an aluminum housing that can be attached to a 4.5" OD pedestal pole. Powder coat the housing with an electrostatically applied, fused-polyester paint in highway yellow (Federal Standard 595C, Color Chip Number 13538) a minimum of 2.5 to 3.5 mils thick. Ensure the housing does not project beyond the outside edges of a W11-2 or S1-1 sign. Ensure the two indications are installed into the housing assembly to face in the direction of the approaching vehicular traffic. When specified, provide two additional identical indications for the motorists in a similar constructed housing that can be attached on the opposite side of the pole.

Provide the two yellow indications facing motorists to flash in a rapidly alternating "wig-wag" flashing sequence (left light on, then right light on). Ensure 70 to 80 periods of flashing per minute with the left indication emitting two slow pulses of light and the right indication emitting four rapid pulses of light followed by a long pulse of light. Ensure the indications have approximately equal periods of rapid pulsing light emissions and dark operation. Ensure flash rates are not at frequencies between 5 and 30 flashes per second to avoid flash-induced seizures. Provide a flashing yellow LED indication on the end of the housing to provide notification of activation and operation of the device to pedestrians in the crosswalk.

During operation, ensure the RRFB remains dark until a pedestrian actuation occurs and then returns back dark at a programmed time after the pedestrian activation. Provide wireless communication equipment to ensure all RRFBs associated at a given crosswalk simultaneously start operation of their alternating rapid flashing indications when activated and cease operation simultaneously. Provide a means to prevent interference with other systems utilizing similar communications equipment.

Provide a 12VDC sealed gel, sealed lead acid, or absorption glass mat battery with sufficient capacity for 5 days of 3 hours of continuous operation with no additional charge from solar panel. Ensure the battery is located in a moisture and corrosion resistant enclosure. Provide a solar panel with a minimum array-to-load ratio of 1.2 and charging circuitry for the battery. Provide a solar sizing report that shows the system loss of load probability is 0% for the entire year for Raleigh, North Carolina. Provide mounting hardware to allow solar panel to be tilted at least 45 degrees from horizontal and panned 360 degrees.

Provide stainless steel fasteners for all items exposed to the weather. For fasteners protected from the weather, provide fasteners fabricated from stainless steel or other corrosion-resistant materials.

Ensure assemblies provide protection from environmental conditions and accidental contact equivalent to a NEMA 3R-rated enclosure. Ensure all components operate properly within the following limits unless otherwise noted:

- Humidity: 5% to 95%, non-condensing
- Ambient Temperature: -30.0°F to +165°F
- Shock - NEMA TS2-2003, Section 2.1.10
- Vibration - NEMA TS2-2003, Section 2.1.9

17.3. CONSTRUCTION METHODS

For each approach to the RRFB location, use two RRFB assemblies, installed at the crosswalk, one on the right-hand side of the roadway and one on the left-hand side of the roadway. On a divided highway, install the left-hand side assembly in the median, if practical, rather than on the far-left side of the highway. Each RRFB assembly shall consist of a W11-2 (Pedestrian) or S1-1 (School) crossing warning sign, a RRFB, and W16-7p (downward diagonal arrow) plaque. Install the RRFB on the same support as the associated W11-2 (Pedestrian) or S1-1 (School) crossing warning sign and plaque. Do not install an RRFB independent of the crossing signs for the approach the RRFB faces.

Ensure that the outside edges of the RRFB indications, including any housings, do not project beyond the outside edges of the W11-2 or S1-1 sign. Locate the RRFB between the bottom of the crossing warning sign and the top of the supplemental W16-7p plaque, rather than 12 inches above or below the sign assembly.

If using pushbuttons to activate the RRFBs (versus passive detection), install the pushbutton assembly below the RRFB and W16-7p plaque. Mount the pushbutton at a minimum height of 3.5 feet but no higher than 4.0 feet above the adjacent pedestrian travel way. With pushbutton activation, mount a pedestrian instructional sign with legend "PUSH BUTTON TO TURN ON WARNING LIGHTS" adjacent to or integral with each pedestrian pushbutton.

Obtain flashing duration to be programmed into the RRFB from the Engineer.

17.4. MEASUREMENT AND PAYMENT

Actual number of rectangular rapid flashing beacon assemblies furnished, installed, and accepted.

No measurement will be made of rapidly flashing rectangular-shaped yellow indications, solar panel, battery, controller assembly, mounting posts, and all necessary hardware as these items will be considered incidental to furnishing and installing rectangular rapid flashing beacon assemblies.

Payment will be made under:

Rectangular Rapid Flashing Beacon AssemblyEach

18. ETHERNET EDGE SWITCH

Furnish and install a managed Ethernet edge switch as specified below that is fully compatible, interoperable, and completely interchangeable and functional within the existing City, Division, or Statewide traffic signal system communications network.

18.1. DESCRIPTION

A. Ethernet Edge Switch:

Furnish and install a hardened, field Ethernet edge switch (hereafter “edge switch”) for the traffic signal controller or ITS device as specified below. Ensure that the edge switch provides wire-speed, fast Ethernet connectivity at transmission rates of 1000 megabits per second from each remote traffic signal controller or ITS device location to the routing switches.

Contact the City or NCDIT to arrange for the programming of the new Field Ethernet Switches with the necessary network configuration data, including but not limited to, the IP Address, Default Gateway, Subnet Mask and VLAN ID information. Provide a minimum ten (10) working days notice to allow the City or NCDIT to program the new devices.

B. Network Management:

Ensure that the edge switch is fully compatible with the existing City, Division, or Statewide Network Management Software.

18.2. MATERIALS

A. General:

Ensure that the edge switch is fully compatible and interoperable with the trunk Ethernet network interface and that the edge switch supports half and full duplex Ethernet communications.

Furnish an edge switch that provide 99.999% error-free operation, and that complies with the Electronic Industries Alliance (EIA) Ethernet data communication requirements using single-mode fiber-optic transmission medium and copper transmission medium. Ensure that the edge switch has a minimum mean time between failures (MTBF) of 10 years, or 87,600 hours, as calculated using the Bellcore/Telcordia SR-332 standard for reliability prediction.

B. Compatibility Acceptance

The Engineer has the authority to require the Contractor to submit a sample Field Ethernet Switch and SFP along with all supporting documentation, software and testing procedures to allow a compatibility acceptance test be performed prior to approving the proposed Field Ethernet Switch and Field Ethernet Transceiver for deployment. **The Compatibility Acceptance testing will ensure that the proposed device is 100% compatible and interoperable with the existing City, Division, or Statewide Signal System network, monitoring software and Traffic Operations Center network hardware.** Allow fifteen (15) working days for the Compatibility Acceptance Testing to be performed

C. Standards:

Ensure that the edge switch complies with all applicable IEEE networking standards for Ethernet communications, including but not limited to:

- IEEE 802.1D standard for media access control (MAC) bridges used with the Spanning Tree Protocol (STP);
- IEEE 802.1Q standard for port-based virtual local area networks (VLANs);
- IEEE 802.1P standard for Quality of Service (QoS);
- IEEE 802.1w standard for MAC bridges used with the Rapid Spanning Tree Protocol (RSTP);
- IEEE 802.1s standard for MAC bridges used with the Multiple Spanning Tree Protocol;
- IEEE 802.1x standard for port based network access control, including RADIUS;

- IEEE 802.3 standard for local area network (LAN) and metropolitan area network (MAN) access and physical layer specifications;
- IEEE 802.3u supplement standard regarding 100 Base TX/100 Base FX;
- IEEE 802.3x standard regarding flow control with full duplex operation; and
- IFC 2236 regarding IGMP v2 compliance.
- IEEE 802.1AB Link Layer Discovery Protocol (LLDP)
- IEEE 802.3ad Ethernet Link Aggregation
- IEEE 802.3i for 10BASE-T (10 Mbit/s over Fiber-Optic)
- IEEE 802.3ab for 1000BASE-T (1Gbit/s over Ethernet)
- IEEE 802.3z for 1000BASE-X (1 Gbit/s Ethernet over Fiber-Optic)

D. Functional:

Ensure that the edge switch supports all Layer 2 management features and certain Layer 3 features related to multicast data transmission and routing. These features shall include, but not be limited to:

- An STP healing/convergence rate that meets or exceeds specifications published in the IEEE 802.1D standard.
- An RSTP healing/convergence rate that meets or exceeds specifications published in the IEEE 802.1w standard.
- An Ethernet edge switch that is a port-based VLAN and supports VLAN tagging that meets or exceeds specifications as published in the IEEE 802.1Q standard, and has a minimum 4-kilobit VLAN address table (254 simultaneous).
- A forwarding/filtering rate that is a minimum of 14,880 packets per second for 10 megabits per second and 148,800 packets per second for 100 megabits per second.
- A minimum 4-kilobit MAC address table.
- Support of Traffic Class Expediting and Dynamic Multicast Filtering.
- Support of, at a minimum, snooping of Version 2 & 3 of the Internet Group Management Protocol (IGMP).
- Support of remote and local setup and management via telnet or secure Web-based GUI and command line interfaces.
- Support of the Simple Network Management Protocol version 3 (SNMPv3). Verify that the Ethernet edge switch can be accessed using the resident EIA-232 management port, a telecommunication network, or the Trivial File Transfer Protocol (TFTP).
- Port security through controlling access by the users. Ensure that the Ethernet edge switch has the capability to generate an alarm and shut down ports when an unauthorized user accesses the network.
- Support of remote monitoring (RMON-1 & RMON-2) of the Ethernet agent.
- Support of the TFTP and SNMP. Ensure that the Ethernet edge switch supports port mirroring for troubleshooting purposes when combined with a network analyzer.

E. Physical Features:

Ports: Provide 10/100/1000 Mbps auto-negotiating ports (RJ-45) copper Fast Ethernet ports for all edge switches. Provide auto-negotiation circuitry that will automatically negotiate the highest possible data rate and duplex operation possible with attached devices supporting the IEEE 802.3 Clause 28 auto-negotiation standard.

Optical Ports: Ensure that all fiber-optic link ports operate at 1310 or 1550 nanometers in single mode. Provide Type LC connectors for the optical ports, as specified in the Plans or by the Engineer. Do not use mechanical transfer registered jack (MTRJ) type connectors.

Provide an edge switch having a minimum of two optical 100/1000 Base X ports capable of transmitting data at 100/1000 megabits per second. Ensure that each optical port consists of a pair of fibers; one fiber will transmit (TX) data and one fiber will receive (RX) data. Ensure that the optical ports have an optical power budget of at least 15 dB. Provide small form-factor pluggable modules (SFPs) with a maximum range that meets or exceeds the distance requirement as indicated on the Plans.

Copper Ports: Provide an edge switch that includes a minimum of four copper ports. Provide Type RJ-45 copper ports and that auto-negotiate speed (i.e., 10/100/1000 Base) and duplex (i.e., full or half). Ensure that all 10/100/1000 Base TX ports meet the specifications detailed in this section and are compliant with the IEEE 802.3 standard pinouts. Ensure that all Category 6 unshielded twisted pair/shielded twisted pair network cables are compliant with the EIA/TIA-568-B standard.

Port Security: Ensure that the edge switch supports/complies with the following (remotely) minimum requirements:

- Ability to configure static MAC addresses access;
- Ability to disable automatic address learning per ports; know hereafter as Secure Port. Secure Ports only forward; and
- Trap and alarm upon any unauthorized MAC address and shutdown for programmable duration. Port shutdown requires administrator to manually reset the port before communications are allowed.

F. Management Capabilities:

Ensure that the edge switch supports all Layer 2 management features and certain Layer 3 features related to multicast data transmission and routing. These features shall include, but not be limited to:

- An STP healing/convergence rate that meets or exceeds specifications published in the IEEE 802.1 D standards;
- An RSTP healing/convergence rate that meets or exceeds specifications published in the IEEE 802.1w standard;
- An Ethernet edge switch that is a port-based VLAN and supports VLAN tagging that meets or exceeds specifications as published in the IEEE 802.1Q standard, and has a minimum 4-kilobit VLAN address table (254 simultaneous);
- A forwarding/filtering rate that is a minimum of 14,880 packets per second for 10 megabits per second, 148,800 packets per second for 100 megabits per second and 1,488,000 packets per second for 1000 megabits per second;
- A minimum 4-kilobit MAC address table;
- Support of Traffic Class Expediting and Dynamic Multicast Filtering.
- Support of, at a minimum, snooping of Version 2 & 3 of the Internet Group Management Protocol (IGMP);
- Support of remote and local setup and management via telnet or secure Web-based GUI and command line interfaces; and

- Support of the Simple Network Management Protocol (SNMP). Verify that the Ethernet edge switch can be accessed using the resident EIA-232 management port, a telecommunication network, or the Trivial File Transfer Protocol (TFTP).

Network Capabilities: Provide an edge switch that supports/complies with the following minimum requirements:

- Provide full implementation of IGMPv2 snooping (RFC 2236);
- Provide full implementation of SNMPv1, SNMPv2c, and/or SNMPv3;
- Provide support for the following RMON–I groups, at a minimum:
 - Part 1: Statistics
 - Part 2: History
 - Part 3: Alarm
 - Part 9: Event
- Provide support for the following RMON–2 groups, at a minimum:
 - Part 13: Address Map
 - Part 16: Layer Host
 - Part 17: Layer Matrix
 - Part 18: User History
- Capable of mirroring any port to any other port within the switch;
- Meet the IEEE 802.1Q (VLAN) standard per port for up to four VLANs;
- Meet the IEEE 802.3ad (Port Trunking) standard for a minimum of two groups of four ports;
- Password manageable;
- Telnet/CLI;
- HTTP (Embedded Web Server) with Secure Sockets Layer (SSL); and
- Full implementation of RFC 783 (TFTP) to allow remote firmware upgrades.

Network Security: Provide an edge switch that supports/complies with the following (remotely) minimum network security requirements:

- Multi-level user passwords;
- RADIUS centralized password management (IEEE 802.1X);
- SNMPv3 encrypted authentication and access security;
- Port security through controlling access by the users: ensure that the Ethernet edge switch has the capability to generate an alarm and shut down ports when an unauthorized user accesses the network;
- Support of remote monitoring (RMON-1&2) of the Ethernet agent; and
- Support of the TFTP and SNTP. Ensure that the Ethernet edge switch supports port mirroring for troubleshooting purposes when combined with a network analyzer.

G. Electrical Specifications:

Ensure that the edge switch operates and power is supplied with 115 volts of alternating current (VAC). Ensure that the edge switch has a minimum operating input of 110 VAC and a maximum operating input of 130 VAC. Ensure that if the device requires operating voltages other than 120 VAC, supply the required voltage converter. Ensure that the maximum power consumption does not exceed 50 watts. Ensure that the edge switch has diagnostic light emitting diodes (LEDs), including link, TX, RX, speed (for Category 6 ports only), and power LEDs.

H. Environmental Specifications:

Ensure that the edge switch performs all of the required functions during and after being subjected to an ambient operating temperature range of -30 degrees to 165 degrees Fahrenheit as

defined in the environmental requirements section of the NEMA TS 2 standard, with a noncondensing humidity of 0 to 95%.

Provide certification that the device has successfully completed environmental testing as defined in the environmental requirements section of the NEMA TS 2 standard. Provide certification that the device meets the vibration and shock resistance requirements of Sections 2.1.9 and 2.1.10, respectively, of the NEMA TS 2 standard. Ensure that the edge switch is protected from rain, dust, corrosive elements, and typical conditions found in a roadside environment.

The edge switch shall meet or exceed the following environmental standards:

- IEEE 1613 (electric utility substations)
- IEC 61850-3 (electric utility substations)
- IEEE 61800-3 (variable speed drive systems)
- IEC 61000-6-2 (generic industrial)
- EMF – FCC Part 15 CISPR (EN5502) Class A

I. Ethernet Patch Cable:

Furnish a factory pre-terminated/pre-connectorized Ethernet patch cable with each edge switch. Furnish Ethernet patch cables meeting the following physical requirements:

- Five (5)-foot length
- Category 6 or better
- Factory-installed RJ-45 connectors on both ends
- Molded anti-snag hoods over connectors
- Gold plated connectors
- Copper-clad aluminum is **NOT** allowed.

Furnish Fast Ethernet patch cords meeting the following minimum performance requirements:

- TIA/EIA-568-B-5, Additional Transmission Performance Specifications for 4-pair 100 Ω Enhanced Category 6 Cabling
- Frequency Range: 1-100 MHz
- Near-End Crosstalk (NEXT): 30.1 dB
- Power-sum NEXT: 27.1 dB
- Attenuation to Crosstalk Ratio (ACR): 6.1 dB
- Power-sum ACR: 3.1 dB
- Return Loss: 10dB
- Propagation Delay: 548 nsec

18.3. CONSTRUCTION METHODS

A. General:

Ensure that the edge switch is UL listed.

Verify that network/field/data patch cords meet all ANSI/EIA/TIA requirements for Category 6 four-pair unshielded twisted pair cabling with stranded conductors and RJ45 connectors.

Contact the City, Division, or NCDIT a minimum of 10 working days prior to installation to allow for the programming of the edge switch.

B. Edge Switch:

Mount the edge switch inside each field cabinet by securely fastening the edge switch to the upper end of the right rear vertical rail of the equipment rack using manufacturer-recommended or Engineer-approved attachment methods, attachment hardware and fasteners.

Ensure that the edge switch is mounted securely in the cabinet and is fully accessible by field technicians without blocking access to other equipment. Verify that fiber-optic jumpers consist of a length of cable that has connectors on both ends, primarily used for interconnecting termination or patching facilities and/or equipment.

18.4. MEASUREMENT AND PAYMENT

Ethernet edge switch will be measured and paid as the actual number of Ethernet edge switches furnished, installed, and accepted.

No separate measurement will be made for Ethernet patch cable, small form factor pluggable modules (SFPs), power cord, mounting hardware, nuts, bolts, brackets, or edge switch programming as these will be considered incidental to furnishing and installing the edge switch.

Payment will be made under:

Ethernet Edge Switch.....Each

19. COMMUNICATIONS SYSTEM SUPPORT EQUIPMENT

19.1. DESCRIPTION

Furnish communications system support equipment with all necessary hardware in accordance with the plans and specifications.

19.2. MATERIALS

A. General:

Furnish equipment with test probes/leads, batteries (for battery-operated units), line cords (for AC-operated units), and carrying cases. Provide operating instructions and maintenance manuals with each item.

Before starting any system testing or training, furnish all communications system support equipment.

B. Fiber-Optic Support Equipment

1. Fiber-optic Restoration Kit:

Furnish a fully functional fiber-optic restoration kit consisting of the following items (minimum):

- Plier-type strippers
- Non-niks fiber stripper tool with procedures
- Buffer tube stripper tool with procedures
- Fiber-optic Cleaver (average cut less than 0.5 degrees from perpendicular) Diamond Blade
- Screw driver set
- 48 Alcohol wipes
- Tape, 3/4-inch, electrician
- Chemical removal wipes

- Metal ruler
- Tweezers
- Crimping pliers
- Mechanical Splice Manual
- Mechanical Splice Fixture
- 12, Non-adhesive, mechanical splices
- 2 Mechanical Splice Trays, 12 Mechanical Splice Devices, Compatible with the Interconnect Centers being installed in the Traffic Signal Controller Cabinets
- Scissors
- Hard-sided, padded, storage case

2. Fiber-optic Power Meter:

Furnish fiber-optic power meters for measuring absolute power and link losses, as well as monitoring power levels and testing threshold levels. Provide the following features:

- Spectral range 750 nm to 1700 nm
- Calibrated wavelengths 850, 1310, and 1550 nm
- Accuracy ± 3 percent (± 0.1 dB) at -20 dBm at 70 degrees F
at calibrated wavelengths
- Readout resolution 4 digits, 0.01 dBm
- Display Backlit LCD
- Fiber-optic connector ST type
- Power-up stabilization Less than five seconds at ambient temperature
- Tone threshold settings User selectable from 1 to 35 dB, plus OFF
- Analog output port
 - Voltage 0 to + 1 V FSD of linear power range
 - Output impedance 5 kilohms, nominal
- Temperature
 - Operating 32 to 122 degrees F
 - Storage 0 to 150 degrees F
- Relative humidity 5 to 95 percent, non-condensing
- Battery power Alkaline: 28 hours; NiCad: 8 hours (recharger and NiCad batteries provided)
- Carrying case

3. Optical Light Generator:

Furnish optical light generators for measuring absolute power and link losses, as well as monitoring power levels and testing threshold levels. Provide the following features:

- Calibrated wavelengths 1310 nm, and 1550 nm
- Accuracy 3 percent at 70 degrees F at calibrated wavelengths
- Fiber-optic connector ST type
- Power-up stabilization Less than five seconds at ambient temperature
- Temperature
 - Operating 32 to 122 degrees F
 - Storage -10 to 150 degrees F

- Relative humidity 5 to 95 percent, non-condensing
- Battery power Alkaline: 28 hours; NiCad: 8 hours (recharger and NiCad batteries provided)
- Carrying case

4. SMFO Transceiver (For Emergency Restoration):

Furnish SMFO transceivers identical to the type installed in the traffic signal controller cabinets to be used for emergency restoration of the system and the fiber-optic communications system.

5. Ethernet Edge Switch (For Emergency Restoration):

Furnish Ethernet Edge Switch identical to the type installed in the traffic signal controller cabinets to be used for emergency restoration of the system and the fiber-optic communications system.

C. Wireless Radio Support Equipment

1. Wireless Radio Modem

Furnish wireless radio modem identical to the type installed in the traffic signal controller cabinets to be used for emergency restoration of the system and the wireless communications system.

2. Lightning Arrestor

Furnish wireless radio lightning arrestors identical to the type installed in the traffic signal controller cabinets to be used for emergency restoration of the transient voltage suppression equipment.

19.3. MEASUREMENT AND PAYMENT

Actual number of fiber-optic restoration kits furnished and accepted.

Actual number of fiber-optic power meters furnished and accepted.

Actual number of optical light generators furnished and accepted.

Actual number of fiber-optic transceivers furnished and accepted.

Actual number of Ethernet Edge Switch furnished and accepted.

Actual number of wireless radio modems furnished and accepted.

Actual number of wireless radio lightning arrestors furnished and accepted.

Payment will be made under:

Furnish Fiber-optic Restoration Kit	Each
Furnish Fiber-optic Power Meter	Each
Furnish Fiber-optic Light Generator	Each
Furnish Fiber-optic Transceiver	Each
Furnished Ethernet Edge Switch	Each
Furnish Wireless Radio Modem	Each
Furnish Wireless Lightning Arrestor	Each

20. FIBER-OPTIC TRAINING**20.1. DESCRIPTION**

Provide training for the installation, operation and maintenance of the fiber-optic communications cable, fiber-optic transceivers, interconnect centers, splice trays and other related fiber-optic equipment in accordance with the plans and specifications.

20.2. MATERIALS

Provide training to properly install, operate, maintain, diagnose and repair each piece of equipment associated with the fiber-optic system. Provide approved manufacturer's representatives or other qualified personnel to conduct training courses. Provide training for a minimum of fifteen Department personnel.

Before beginning the training course, submit detailed course curricula, draft manuals, and handouts, and resumes of the instructors for review and approval. The Engineer may request modification of the material and request courses desired by the Department.

Conduct all training courses at a location provided by the Department within the Division and at a time mutually agreed upon, but not later than the start of fiber-optic cable testing. Provide training material, manuals, and other handouts to serve not only as subject guidance, but also as quick reference for use by the students. Deliver course material in reproducible form immediately following the course.

Record each training course onto a digital platform and deliver to the Engineer.

Provide instruction on basic fiber-optic theories and principals as well as the installation, operation, maintenance, identification, detection, and correction of malfunctions in fiber-optic communications cable and related hardware. Include field level troubleshooting as an integral part of the training.

Provide training for the fiber-optic system for the following categories and for the minimum number of hours shown:

COURSE OUTLINES (L = Lecture; D = Demonstration; H = Hands-on by Student)

TRANSCEIVER**DAY 1 (4 Hours)**

Safety - (L)

Introduction to transceivers - (L)

Review of Maintenance Manual - (L)

Review of Operations Manual - (L)

Question and answer session

FIBER-OPTIC CABLE SYSTEM

DAY 1 (8 Hours)

Safety - (L)

Introduction to fiber optics, theory, and principals - (L)

Fiber and cable types -(L, H)

National Electrical Code considerations - (L, H)

plenum and riser type cable

out door cable, etc.

Introduction to terminating hardware, end equipment, and applications - (L, D, H)

connectors (ST, SC, etc.)

splice enclosure, splice trays, and connector panels

cable placement techniques

Question and answer session

DAY 2 (8 Hours)

Cable handling and preparation (sheath removal, grip installation, etc.) - (L, D, H)

Splicing and terminating methods - (L, D, H)

mechanical splicing using various techniques

fusion splicing

field termination of connectors types

Introduction to cable plant testing procedures - (L, D, H)

proper usage of optical light generator and power meter

optical time domain reflectometer usage

Class project (build working system using cables/connectors made by attendees) - (L, D, H)

Question and answer session

DAY 3 (4 Hours)

Class project -- Testing and troubleshooting -- (L, D, H)

Cable system maintenance and restoration -- (L)

Question and answer session

20.3. MEASUREMENT AND PAYMENT

Lump sum for fiber-optic training with training packages completed and accepted.

Payment will be made under:

Fiber-optic TrainingLump Sum

21. SOLAR POWER, 900 MHZ SPREAD SPECTRUM RADIO**21.1. DESCRIPTION**

Furnish an operational Solar Power, 900MHz Spread Spectrum Radio System installed in a NEMA Type 3R enclosure for pole mounting.

Furnish material and workmanship conforming to the *National Electrical Code* (NEC), the *National Electrical Safety Code* (NESEC), Underwriter's Laboratories (UL) or a third-party listing agency accredited by the North Carolina Department of Insurance, and all local safety codes in effect on the date of advertisement. Comply with all regulations and codes imposed by the owner of affected utility poles.

21.2. MATERIALS**A. 900MHz Wireless Radio System:**

Furnish a 900 MHz Radio that complies with Section 1098 of the 2024 Standard Specifications for Roads and Structures.

B. Solar Powered Assembly:**B.1 General:**

Furnish a Solar Power Assembly consisting of the following:

- Solar Array
- Solar Charge Controller
- Load Controller
- Battery(ies)
- NEMA 3R Equipment Cabinet

Ensure that DC disconnects are supplied between the Solar Array and the Solar Charge Controller, and between the Solar Charge Controller and the Battery(ies), and between the Battery(ies) and any other equipment.

B.2 Solar Power System Design Requirements:

Provide to the Engineer for Approval, a submittal package with Engineering Calculations consisting of, as a minimum, schematic drawing, technical data sheets, and supporting documentation. Ensure the documentation demonstrates, in theory, that the battery(ies) will provide for continuous operation for a minimum of ten (10) consecutive days with no additional charging under the following conditions:

- a) Fully powering the Wireless Repeater Radio operating 24 hours a day with 50% of that time being in a standby (sleep) mode; and 50% of the time being in operational mode.

Provide drawings showing dimension, location of required equipment, cabinet electrical diagrams, part numbers and descriptions of required equipment and accessories to the Engineer.

B.3 Solar Array:

Furnish solar modules with a minimum 20-year factory warranty. The solar array should have a minimum peak output of 80 Watts. Solar modules must be UL listed, FM Class I, Div II, Group C&D

approved. For the solar array, power wiring should be 10-2, stranded copper, double insulated, sunlight resistant, 600V 90C rated cable. Ensure the solar array mount is manufactured from an aluminum alloy or stainless steel and is capable of withstanding 140 mph winds.

B.4 Solar Charger Controller:

Furnish a Pulse Width Modulation (PWM) solar charge controller that is UL listed, with a minimum 20A solid state, low voltage disconnect. The solar charge controller must be sealed with internal temperature compensation, lightning protection, reverse polarity protection, and LED indicators. Furnish controllers with the capability of 3 functions: battery charging, load control, and diversion regulation. Controllers must be furnished with fully adjustable DIP switches and RS-232 communications port to adjust the unit's operational modes. Ensure the solar charge controller is listed as a FM Class I, Div. II, Groups ABCD device and has the CE mark.

B.5 Load Controller:

Furnish a load controller that is identical to the solar charger controller provided as part of the solar power assembly. Configure the load controller to regulate the voltage of the assembly according to the manufacturer's recommendation.

B.6 Batteries:

Provide a 12V gel electrolyte, non-spillable, maintenance free battery. The battery(ies) should be able to provide power for 10 days without being charged by the Solar Array. Furnish battery(ies) with a minimum operating temperature of -76° F to 140°F.

B.7 NEMA 3R Equipment Cabinet:

Provide a NEMA 3R type Equipment Cabinet enclosure that is of a pole mount design, with compartments to house the battery(ies) and electronic components separately. Ensure that the equipment installed inside the cabinet does not occupy more than 60% of the total cabinet volume.

Ensure that the battery compartment and the electronic equipment compartments are ventilated with a screen and louvered vents. Equip vents with standard-size, replaceable furnace type vent filters. Size the filter tray to adequately house and secure the filter in place. Ensure there are no obstructions on the interior face of the door to interfere with easy removal and replacement of filter.

Provide an enclosure that is fabricated with unpainted, natural, aluminum that complies with Section 7 of NEMA TS-2-1998. Ensure the equipment cabinet enclosure shell is fitted with one (1) Corbin Number 2 Key, lifting handles, exhaust ports. Provide all necessary hardware to mount the enclosure securely to the pole. Provide hardware that is stainless steel or a Department approved non-corrosive alternate including the hinges and lifting handle.

Provide roof with slope (from front to back) at a minimum ratio of 1" drop per 2 feet. Ensure roof is flush with front of the door. Ensure each exterior cabinet plane surface is constructed of a single sheet of seamless aluminum.

Provide a handle and three point latching mechanism designed to be disassembled using hand tools. Provide a shaft connecting the latching plate to the door handle by passing through the door within a bushing, bearing, or equivalent device. Provide a latching plate at least 1/8 inch thick and that mates securely with the lock bolt. Provide a lock bolt with a flat end (no bevel) and that has at least 1/4 inch of length in contact with the latching plate.

Ensure that the handle and lock are positioned so that the lock does not lie in the path of the rotating handle as the door is unlatched and that the handle points down in the latched position.

Provide a main door opening that encompasses the full frontal area of the cabinet shell. Ensure that the cabinet shell is sturdy and does not exhibit noticeable flexing, bending or distortion under normal conditions, except that a minor amount of flexing is permitted in the main door when the cabinet is open. In such case, the flexing must not result in permanent deformation of the door.

A police panel door is not required for these cabinets.

Equipment in the equipment cabinet enclosure will be shelf mounted. Provide one equipment shelf in the cabinet that extends the practical width of the cabinet. Ensure that the shelf can be moved up and down within the cabinet. Do not locate permanently mounted equipment in such a way that will restrict access to terminals. Ensure all components are arranged for easy access during servicing. When modular in construction, provide guides and positive connection devices to ensure proper pin alignment and connection.

Arrange equipment and terminals within the cabinet so that they will not interfere with the entrance, tracing and connection of conductors or other cables. Ensure all incoming and outgoing conductors are connected to terminal blocks. Ensure all field terminals are readily accessible without having to remove equipment to gain access. Ensure terminals are not located on the underside of shelf or at any other place where they are not readily visible or where they may present a hazard to personnel who might inadvertently touch them.

Provide terminal blocks that are made of electrical grade thermoplastic or thermosetting plastic. Ensure each terminal block is of closed back design and has recessed-screw terminals with molded barriers between terminals. Ensure each terminal consists of two terminal screws with removable shorting bar between them. Ensure all terminal blocks and terminals are labeled with their intended functions. Provide labels that are visible and easy to read when the terminal blocks are wired.

21.3. CONSTRUCTION METHODS

A. Antenna Mounting:

The Engineer will approve final locations of any solar powered radio systems. Install the antenna, antenna mounting hardware, coaxial cable, power divider, antenna splitter cable and additional antenna at locations where it is determined that a dual antenna configuration is necessary to accommodate communications in multiple directions.

Install antenna in accordance with the antenna manufacturer's recommendations. Secure the antenna mounting hardware to the pole and route the coaxial cable such that no strain is placed on the N-Type Male coaxial connectors.

Install the coaxial cable shield grounding system by removing the outer jacket of the coaxial cable without damaging the cable shield. Install the shield grounding system following the cable manufacturer's recommendations. Install and weatherproof the connection using the appropriate weatherproofing materials and following the manufacturer's recommendations. On wood poles, secure the #6 AWG grounding lead cable to the pole ground using split bolt or compression type fitting or an Engineer approved method. On metal poles, secure the #6 AWG grounding lead cable to the pole using an Engineer approved method.

Install the coaxial cable in a 2 inch riser with weatherhead for connecting into the equipment cabinet. Do not exceed the 1-inch bend radius of the coaxial cable as it traverses from the cabinet to the antenna assembly. Connect the lightning arrestor to the coaxial cable in the equipment cabinet. Properly ground and secure the arrestor in the cabinet. Permanently label all cables entering the cabinet.

Place a copy of all manufacturer equipment specifications and instruction and maintenance manuals in the equipment cabinet.

B. Solar Power Assembly:

Do not obstruct the sight distance of vehicles when locating and installing the equipment cabinet. Mount equipment cabinet so that the height to the middle of the cabinet is 4 feet above grade. Secure the cabinet to the pole using $\frac{3}{4}$ " stainless steel straps or a method approved by the Engineer.

Ensure that the equipment cabinet along with solar array(s) and its mounting hardware are capable of surviving sustains winds of 140 MPH. Ensure the solar array(s) does not obstruct the view of traffic and that the array(s) are arranged for optimal sunlight exposure for charging of the battery(ies). Mount the array(s) at a minimum height of 25 feet above ground level.

Run field wiring from the solar power array(s) to the equipment cabinet through 1 inch riser with weatherhead and make connections inside the equipment cabinets as required. Install separate DC disconnects between the solar array and the solar charger controller and between the solar charger controller and the battery(ies), and between the battery(ies) and any other equipment. Ensure the DC disconnect allows personnel working on the system to safely isolate critical items from each other while performing maintenance and trouble shooting. Ensure that all wiring including grounding of the solar photovoltaic system meets the requirements of Article 690 of the National Electric Code (NEC) and these project special provisions.

To protect against high voltage power surges, furnish and install one grounding electrode at the equipment cabinet.

Terminate all wires using spade connectors under binding screws on terminal blocks. Label all terminal blocks and terminals for easy identification. Label all wires and harnesses for easy identification. Neatly secure all wiring and harness inside the cabinet in a method approved by the Engineer.

Provide and leave all data interface cables, installation manuals, and specifications and materials used to program any equipment in the Equipment Cabinet. Program all equipment for operation.

21.4. MEASUREMENT AND PAYMENT

Actual number of Solar Power, 900MHz Spread Spectrum Radio Systems furnished, installed and accepted.

This item includes the appropriate sized Solar Power Assembly (Solar Array, Solar Charger Controller, Battery, NEMA 3R equipment cabinet), 1 inch riser with weatherhead, 2 inch riser with weatherhead, antenna(s), radio, data interface cable/serial cable, coaxial cable, lightning arrestor, radio frequency signal jumper, coaxial cable power divider (Splitter), coaxial cable connectors, coaxial cable shield grounding system with weatherproofing, labeling and any integration, installation materials and configuration software necessary to complete this work, including the Solar Power System Design Calculations and warranties, will be incidental.

Payment will be made under:

Solar Power, 900MHz Spread Spectrum RadioEach

22. DIGITAL CCTV CAMERA ASSEMBLY

22.1. DESCRIPTION

Furnish and install a Digital CCTV Camera Assembly as described in these Project Special Provisions. All new CCTV cameras shall be fully compatible with the video management software currently in use by the Region and the Statewide Traffic Operations Center (STOC). Provide a Pelco Spectra Enhanced low light 30X minimum zoom, Axis Dome Network Camera low light 30X minimum zoom or an approved equivalent that meets the requirements of these Project Special Provisions.

22.2. MATERIALS

A. General

Furnish and install new CCTV camera assembly at the locations shown on the Plans and as approved by the Engineer. Each assembly consists of the following:

- One dome CCTV color digital signal processing camera unit with zoom lens, filter, control circuit, and accessories in a single enclosed unit
- A NEMA-rated enclosure constructed of aluminum with a clear acrylic dome or approved equal Camera Unit housing.
- Motorized pan, tilt, and zoom
- Built-in video encoder capable of H.264/MPEG-4 compression for video-over IP transmission
- Pole-mount camera attachment assembly
- A lightning arrestor installed in-line between the CCTV camera and the equipment cabinet components.
- All necessary cable, connectors and incidental hardware to make a complete and operable system.

B. Camera and Lens

1. Cameras

Furnish a new CCTV camera that utilizes charged-coupled device (CCD) technology or Complementary Metal-Oxide-Semiconductor (CMOS) technology. The camera must meet the following minimum requirements:

- Video Resolution: Minimum 1920x1080 (HDTV 1080p)
- Aspect Ratio: 16:9
- Overexposure protection: The camera shall have built-in circuitry or a protection device to prevent any damage to the camera when pointed at strong light sources, including the sun
- Low light condition imaging
- Wide Dynamic Range (WDR) operation
- Electronic Image Stabilization (EIS)

- Automatic focus with manual override

2. Zoom Lens

Furnish each camera with a motorized zoom lens that is a high-performance integrated dome system or approved equivalent with automatic iris control with manual override and neutral density spot filter. Furnish lenses that meet the following optical specifications:

- 30X minimum optical zoom, and 12X minimum digital zoom
- Preset positioning: minimum of 128 presets

The lens must be capable of both automatic and remote manual control iris and focus override operation. The lens must be equipped for remote control of zoom and focus, including automatic movement to any of the preset zoom and focus positions. Mechanical or electrical means must be provided to protect the motors from overrunning in extreme positions. The operating voltages of the lens must be compatible with the outputs of the camera control.

3. Communication Standards:

The CCTV camera shall support the appropriate NTCIP 1205 communication protocol (version 1.08 or higher), ONVIF Profile G protocol, or approved equal.

4. Networking Standards:

- Network Connection: Minimum 10/100 Mbps auto-negotiate
- Frame Rate: 30 to 60 fps
- Data Rate: scalable
- Built-in Web Server
- Unicast & multicast support
- Two simultaneous video streams (Dual H.264 and MJPEG):
 - Video 1: H.264 (Main Profile, at minimum)
 - Video 2: H.264 or MJPEG
- Supported Protocols: DNS, IGMPv2, NTP, RTSP, RTP, TCP, UDP, DHCP, HTTP, IPv4, IPv6
- 130 db Wide Dynamic Range (WDR)

The video camera shall allow for the simultaneous encoding and transmission of the two digital video streams, one in H.264 format (high-resolution) and one in H.264 or MJPEG format (low-resolution).

Initially use UDP/IP for video transport and TCP/IP for camera control transport unless otherwise approved by the Engineer.

The 10/100BaseTX port shall support half-duplex or full-duplex and provide auto negotiation and shall be initially configured for full-duplex.

The camera unit shall be remotely manageable using standard network applications via web browser interface administration. Telnet or SNMP monitors shall be provided.

C. Camera Housing

Furnish new dome style enclosure for the CCTV assembly. Equip each housing with mounting assembly for attachment to the CCTV camera pole. The enclosures must be equipped with a sunshield and be fabricated from corrosion resistant aluminum and finished in a neutral color of

weather resistant enamel. The enclosure must meet or exceed NEMA 4X ratings. The viewing area of the enclosure must be tempered glass. The pendant must meet NEMA Type 4X, IP66 rating and use 1-1/2-inch NPT thread. The sustained operating temperature must be -50 to 60C (-58 to 144F), condensing temperature 10 to 100% Relative Humidity (RH).

D. Pan and Tilt Unit

Equip each new dome style assembly with a pan and tilt unit. The pan and tilt unit must be integral to the high-performance integrated dome system. The pan and tilt unit must be rated for outdoor operation, provide dynamic braking for instantaneous stopping, prevent drift, and have minimum backlash. The pan and tilt units must meet or exceed the following specifications:

- Pan: continuous 360 Degrees rotation
- Tilt: up/down +2 to -90 degrees minimum
- Motors: Two-phase induction type, continuous duty, instantaneous reversing
- Preset Positioning: minimum of 128 presets
- Low latency for improved Pan and Tilt Control
- FCC, Class A; UL/cUL Listed

E. Video Ethernet Encoder

Furnish cameras with a built-in digital video Ethernet encoder to allow video-over-IP transmission. The encoder units must be built into the camera housing and require no additional equipment to transmit encoded video over IP networks.

Encoders must have the following minimum features:

- Network Interface: Ethernet 10/100Base-TX (RJ-45 connector)
- Protocols: IPv4, Ipv6, HTTP, UpnP, DNS, NTP, RTP, RTSP, TCP, UDP, IGMP, and DHCP
- Security: SSL, SSH, 802.1x, HTTPS encryption with password-controlled browser interface
- Video Streams: Minimum 2 simultaneous streams, user configurable
- Compression: H.264 (MPEG-4 Part 10/AVC)
- Resolution Scalable: NTSC-compatible 320x176 to 1920x1080 (HDTV 1080p)
- Aspect Ratio: 16:9
- Frame Rate: 1-30 FPS programmable (full motion)
- Bandwidth: 30 kbps – 6 Mbps, configurable depending on resolution
- Edge Storage: SD/SDHC/SDXC slot supporting up to 64GB memory card

F. Control Receiver/Driver

Provide each new camera unit with a control receiver/driver that is integral to the CCTV dome assembly. The control receiver/driver will receive serial asynchronous data initiated from a camera control unit, decode the command data, perform error checking, and drive the pan/tilt unit, camera controls, and motorized lens. As a minimum, the control receiver/drivers must provide the following functions:

- Zoom in/out
- Automatic focus with manual override
- Tilt up/down

- Automatic iris with manual override
- Pan right/left
- Minimum 128 preset positions for pan, tilt, and zoom, 16 Preset Tours, 256 Dome Presets
- Up to 32 Window Blanks.

In addition, each control receiver/driver must accept status information from the pan/tilt unit and motorized lens for preset positioning of those components. The control receiver/driver will relay pan, tilt, zoom, and focus positions from the field to the remote camera control unit. The control receiver/driver must accept “goto” preset commands from the camera control unit, decode the command data, perform error checking, and drive the pan/tilt and motorized zoom lens to the correct preset position. The preset commands from the camera control unit will consist of unique values for the desired pan, tilt, zoom, and focus positions.

G. Electrical

The camera assembly shall support Power-over-Ethernet (PoE) in compliance with IEEE 802.3. Provide any external power injector that is required for PoE with each CCTV assembly.

H. CCTV Camera Attachment to Pole

Furnish and install an attachment assembly for the CCTV camera unit. Use stainless steel banding approved by the Engineer.

Furnish CCTV attachments that allow for the removal and replacement of the CCTV enclosure as well as providing a weatherproof, weather tight, seal that does not allow moisture to enter the enclosure.

Furnish a CCTV Camera Attachment Assembly that can withstand wind loading at the maximum wind speed and gust factor called for in these Special Provisions and can support a minimum camera unit dead load of 45 pounds (20.4 kg).

I. Riser

Furnish material meeting the requirements of Section 1091-3 and 1098-5 of the 2024 Standard Specifications for Roads and Structures. Furnish a 1” riser with weatherhead for instances where the riser is only carrying an Ethernet cable. For installations where fiber optic cable is routed to the cabinet through a 2” riser with heat shrink tubing the Contractor may elect to install the Ethernet cable in the same riser with the fiber cable.

J. Data line Surge Suppression

Furnish data line surge protection devices (SPD) shall meet the following minimum requirements:

- UL497B
- Service Voltage: < 60 V
- Protection Modes: L-G (All), L-L (All)
- Response Time: <5 nanoseconds
- Port Type: Shielded RJ-45 IN/Out
- Clamping Level: 75 V
- Surge Current Rating: 20 kA/Pair
- Power Handling: 144 Watts
- Data Rate: up to 10 GbE

- Operating Temperature: -40° F to + 158° F
- Standards Compliance: Cat-5e, EIA/TIA 568A and EIA/TIA 568B
- Warranty: Minimum of 5-year limited warranty

The data line surge protector shall be designed to operate with Power Over Ethernet (POE) devices. The SPD shall be designed such that when used with shielded cabling, a separate earth ground is not required. It shall be compatible with Cat-5e, Cat 6, and Cat-6A cablings.

Protect the electrical and Ethernet cables from the CCTV unit entering the equipment cabinet with surge protection. Provide an integrated unit that accepts unprotected electrical and Ethernet connections and outputs protected electrical and Ethernet connections.

K. POE Injector

Furnish POE Injectors meeting the following minimum performance requirements and that is compatible with the CCTV Camera and Ethernet Switch provided for the project.

- Working temp/humidity: 14° F to 131° F/maximum 90%, non-condensing
- Connectors: Shielded RJ-45, EIA 568A and EIA 568B
- Input Power: 100 to 240 VAC, 50 to 60 Hz
- Pass Through Data Rates: 10/100/1000 Mbps
- Regulatory: IEEE 802.3at (POE)
- Number of Ports: 1 In and 1 Out
- Safety Approvals: UL Listed

Ensure the POE Injector is designed for Plug-and-Play installation, requiring no configurations and supports automatic detection and protection of non-standard Ethernet Terminal configurations.

22.3. CONSTRUCTION METHODS

A. General

Obtain approval of the camera locations and orientation from the Engineer prior to installing the CCTV camera assembly.

Mount CCTV camera units at a height to adequately see traffic in all directions and as approved by the Engineer. The maximum attachment height is 45 feet above ground level unless specified elsewhere or directed by the Engineer.

Mount the CCTV camera units such that a minimum 5 feet of clearance is maintained between the camera and the top of the pole to ensure adequate lightning protection is provided by the air terminal.

Mount CCTV cameras on the side of poles nearest intended field of view. Avoid occluding the view with the pole.

Install the data line surge protection device and POE Injector in accordance with the manufacturer's recommendations.

Install the riser in accordance with Section 1722 of the 2024 Standard Specifications for Roads and Structures. Install the Ethernet cable in the riser from the field cabinet to the CCTV camera.

B. Electrical and Mechanical Requirements

Install an “Air Terminal and Lightning Protections System” in accordance with the Air Terminal and Lightning Protection System Project Special Provisions for the CCTV Camera Assembly. Ground all equipment as called for in the Standard Specifications, these Special Provisions, and the Plans. **Do not install lightning protection when installing a CCTV camera assembly on a signal pole.**

Install surge protectors on all ungrounded conductors entering the CCTV enclosure.

C. General Test Procedure

Test the CCTV Camera and its components in a series of functional tests and ensure the results of each test meet the specified requirements. These tests should not damage the equipment. The Engineer will reject equipment that fails to fulfill the requirements of any test. Resubmit rejected equipment after correcting non-conformities and re-testing; completely document all diagnoses and corrective actions. Modify all equipment furnished under this contract, without additional cost to the Department, to incorporate all design changes necessary to pass the required tests.

Provide 4 copies of all test procedures and requirements to the Engineer for review and approval at least 30 days prior to the testing start date.

Only use approved procedures for the tests. Include the following in the test procedures:

- A step-by-step outline of the test sequence that demonstrates the testing of every function of the equipment or system tested
- A description of the expected nominal operation, output, and test results, and the pass / fail criteria
- An estimate of the test duration and a proposed test schedule
- A data form to record all data and quantitative results obtained during the test
- A description of any special equipment, setup, manpower, or conditions required by the test

Provide all necessary test equipment and technical support. Use test equipment calibrated to National Institute of Standards and Technology (NIST) standards. Provide calibration documentation upon request.

Conform to these testing requirements and the requirements of these specifications. It is the Contractor’s responsibility to ensure the system functions properly even after the Engineer accepts the CCTV test results.

Provide 4 copies of the quantitative test results and data forms containing all data taken, highlighting any non-conforming results and remedies taken, to the Engineer for approval. An authorized representative of the manufacturer must sign the test results and data forms.

D. Compatibility Tests

1. CCTV System

Compatibility Tests are applicable to CCTV cameras that the Contractor wishes to furnish but are of a different manufacturer or model series than the existing units installed in the Region. If required, the Compatibility Test shall be completed and accepted by the Engineer prior to approval of the material submittal.

The Compatibility Test shall be performed in a laboratory environment at a facility chosen by the Engineer based on the type of unit being tested. Provide notice to the Engineer with the material submitted that a Compatibility Test is requested. The notice shall include a detailed test plan that will show compatibility with existing equipment. The notice shall be given a minimum of 15 calendar days prior to the beginning of the Compatibility Test.

The Contractor shall provide, install, and integrate a full-functioning unit to be tested. The Department will provide access to existing equipment to facilitate these testing procedures. The Engineer will determine if the Compatibility Test was acceptable for each proposed device. To prove compatibility the Contractor is responsible for configuring the proposed equipment at the applicable Traffic Operations Center (TOC) with the accompaniment of an approved TOC employee.

E. Operational Field Test (On-Site Commissioning)

1. CCTV System

Final CCTV locations must be field verified and approved by the Engineer. Perform the following local operational field tests at the camera assembly field site in accordance with the test plans and in the presence of the Engineer. The Contractor is responsible for providing a laptop for camera control and positioning during the test. After completing the installation of the camera assemblies, including the camera hardware, power supply, and connecting cables, the contractor shall:

F. Local Field Testing

Furnish all equipment and labor necessary to test the installed camera and perform the following tests before any connections are made.

- Verify that physical construction has been completed.
- Inspect the quality and tightness of ground and surge protector connections.
- Check the power supply voltages and outputs, check connection of devices to power source.
- Verify installation of specified cables and connection between the camera, PTZ, camera control receiver, and control cabinet.
- Make sure cabinet wiring is neat and labeled properly; check wiring for any wear and tear; check for exposed or loose wires.
- Perform the CCTV assembly manufacturer's initial power-on test in accordance with the manufacturer's recommendation.
- Set the camera control address.
- Exercise the pan, tilt, zoom, and focus operations along with preset positioning, and power on/off functions.
- Demonstrate the pan, tilt and zoom speeds and movement operation meet all applicable standards, specifications, and requirements.
- Define, test and/or change presets.
- Ensure camera field of view is adjusted properly and there are no objects obstructing the view.
- Ensure camera lens is dust-free.
- Ensure risers are bonded and conduits entering cabinets are sealed properly.
- Lightning arrestor bonded correctly.

G. Central Operations Testing

- Interconnect the CCTV Camera’s communication interface device with one of the following methods as depicted on the plans:
 - communication network’s assigned Ethernet switch and assigned fiber-optic trunk cable and verify a transmit/receive LED is functioning and that the CCTV camera is fully operational at the TOC.

OR

- to the DOT furnished cellular modem and verify a transmit/receive LED is functioning and that the CCTV camera is fully operational at the TOC.
- Exercise the pan, tilt, zoom, and focus operations along with preset positioning, and power on/off functions.
- Demonstrate the pan, tilt and zoom speeds and movement operation meet all applicable standards, specifications, and requirements.
- Define, test and/or change presets.

Approval of Operational Field Test results does not relieve the Contractor to conform to the requirements in these Project Special Provisions. If the CCTV system does not pass these tests, document a correction or substitute a new unit as approved by the Engineer. Re-test the system until it passes all requirements.

22.4. MEASUREMENT AND PAYMENT

Digital CCTV Camera Assembly will be measured and paid as the actual number of digital CCTV assemblies furnished, installed, integrated, and accepted. No separate measurement will be made for electrical cabling, connectors, CCTV camera attachment assemblies, conduit, condulets, risers, grounding equipment, surge protectors, PoE Injectors, PoE Cable, Air Terminal and Lightning Protection System, compatibility testing, operational testing or any other equipment or labor required to install the digital CCTV assembly.

Payment will be made under:

Digital CCTV Camera AssemblyEach

23. CCTV FIELD EQUIPMENT CABINET

23.1. DESCRIPTION

For standalone CCTV Camera installations, furnish pole mounted cabinets and all necessary hardware in accordance with the plans and specifications to house CCTV control and transmission equipment.

23.2. MATERIALS**A. CCTV Cabinet**

Furnish Type 336S style or equivalent pole-mounted cabinet meeting the following minimum requirements:

- Single doors on both front and rear of cabinet;
- Grounding bus bar;
- 19-inch rack system for mounting of all devices in the cabinet;
- Pull-out shelf drawer for laptop and maintenance use;
- Maintenance access connections;
- LED lighting;
- Ventilation fans;
- 120VAC power supply;
- 120VAC ground fault circuit interrupter (GFCI)-protected duplex outlets for tools;
- 120VAC surge-protected duplex outlets for equipment.
- Lightning and surge protection on incoming and outgoing electrical lines (power and data);
- UPS with sufficient capacity to hold hub's electrical load for 4 hours.
- Managed Ethernet Edge switch if called for in the plans (paid separately);
- Fiber-optic interconnect centers if called for in the plans (paid separately)

Furnish terminal blocks for power for cabinet CCTV and communications devices as needed to accommodate the number of devices in the cabinet.

Furnish all conduits, shelving, mounting adapters, and other equipment as necessary to route cabling, mount equipment and terminate conduit in the equipment cabinet.

B. Shelf Drawer

Provide a pull out, hinged-top drawer, having sliding tracks, with lockout and quick disconnect feature, such as a Vent-Rak Retractable Writing Shelf, #D-4090-13 or equivalent in the equipment cabinet. Furnish a pullout drawer that extends a minimum of 14 inches that is capable of being lifted to gain access to the interior of the drawer. Minimum interior dimensions of the drawer are to be 1 inch high, 13 inches deep, and 16 inches wide. Provide drawers capable of supporting a 40-pound device or component when fully extended.

C. Cabinet Light

Each cabinet must include two (2) LED lighting fixtures (one front, one back) mounted horizontally inside the top portion of the cabinet. The fixtures must include a cool white lamp and must be operated by normal power factor UL-listed ballast. A door-actuated switch must be installed to turn on the applicable cabinet light when the front door or back door is opened. The lights must be mounted not to interfere with the upper door stay.

D. Surge Protection for System Equipment

Each cabinet must be provided with devices to protect the CCTV and communications equipment from electrical surges and over voltages as described below.

1. Main AC Power Input

Each cabinet must be provided with a hybrid-type, power line surge protection device mounted inside the power distribution assembly. The protector must be installed between the applied line voltage and earth ground. The surge protector must be capable of reducing the effect of lighting transient voltages applied to the AC line. The protector must be mounted inside the Power Distribution Assembly housing facing the rear of the cabinet. The protector must include the following features and functions:

- Maximum AC line voltage: 140 VAC.
- Twenty pulses of peak current, each of which must rise in 8 microseconds and fall in 20 microseconds to ½ the peak: 20000 Amperes.
- The protector must be provided with the following terminals:
 - Main Line (AC Line first stage terminal).
 - Main Neutral (AC Neutral input terminal).
 - Equipment Line Out (AC line second state output terminal, 19 amps).
 - Equipment Neutral Out (Neutral terminal to protected equipment).
 - GND (Earth connection).
- The Main AC line in and the Equipment Line out terminals must be separated by a 200 Microhenry (minimum) inductor rated to handle 10 AMP AC Service.
- The first stage clamp must be between Main Line and Ground terminals.
- The second stage clamp must be between Equipment Line Out and Equipment Neutral.
- The protector for the first and second stage clamp must have an MOV or similar solid state device rated at 20 KA and must be of a completely solid-state design (i.e., no gas discharge tubes allowed).
- The Main Neutral and Equipment Neutral Out must be connected together internally and must have an MOV similar solid-state device or gas discharge tube rated at 20 KA between Main Neutral and Ground terminals.
- Peak Clamp Voltage: 350 volts at 20 KA. (Voltage measured between Equipment Line Out and Equipment Neutral Out terminals. Current applied between Main Line and Ground Terminals with Ground and Main Neutral terminals externally tied together).
- Voltage must never exceed 350 volts.
- The Protector must be epoxy-encapsulated in a flame-retardant material.
- Continuous service current: 10 Amps at 120 VAC RMS.
- The Equipment Line Out must provide power to cabinet CCTV and communications equipment.

2. Ground Bus

Provide a neutral bus that is not connected to the earth ground or the logic ground anywhere within the cabinet. Ensure that the earth ground bus and the neutral ground bus each have ten compression type terminals, each of which can accommodate wires ranging from number 14 through number 4 AWG.

3. Uninterruptible Power Supply (UPS)

Furnish UPS with external temperature monitoring that will shut off when running on battery power and the maximum operating temperature for the ethernet switch is reached.

Install UPS with RJ-45 ethernet network monitoring ports that can be disabled via the UPS software/firmware.

Contractor is responsible for supplying a UPS and batteries that can adequately power the cabinet load plus an additional 20% for a **minimum** of 4 hours. Contractor shall request the power requirements for any department supplied equipment prior to submitting UPS for approval. Allow eight (8) weeks for the department to supply equipment power requirements. Provide to the Engineer for Approval, a submittal package with Engineering Calculations consisting of, as a minimum, schematic drawing, technical data sheets, and supporting documentation. Ensure the documentation demonstrates, in theory, that the battery(ies) will provide for continuous operation for a minimum of four (4) consecutive hours with no additional charging.

Furnish and install one rack mounted UPS in each new cabinet that meet the following **minimum** specifications:

Output

Nominal Output Voltage	120V
Output Voltage Distortion	Less than 5% at full load
Output Frequency (sync to mains)	57 - 63 Hz for 60 Hz nominal
Crest Factor	up to 5:1
Waveform Type	Sine wave
Output Connections	(4) NEMA 5-15R

Input

Nominal Input Voltage	120V
Input Frequency	50/60 Hz +/- 3 Hz (auto sensing)
Input Connections	NEMA 5-15P
Input voltage range for main operations	82 - 144V
Input voltage adjustable range for mains operation	75 -154 V

Battery Type

Maintenance-free sealed Lead-Acid battery with suspended electrolyte, leak-proof.

Typical recharge time	2 hours
-----------------------	---------

Communications & Management

Interface Port(s)	DB-9 RS-232, USB,RJ-45 Ethernet
Control panel	LED status display with load and battery bar-graphs

Surge Protection and Filtering

Surge energy rating	480 Joules
---------------------	------------

Environmental

Operating Environment -32 - 165 °F
Operating Relative Humidity 0 - 95%

Conformance

Regulatory Approvals FCC Part 15 Class A, UL 1778

23.3. CONSTRUCTION METHODS

A. General

For each field equipment cabinet installation, use stainless steel banding or other methods approved by the Engineer to fasten the cabinet to the pole. Install field equipment cabinets so that the height to the middle of the enclosure is 4 feet from ground level. No risers shall enter the top or sides of the equipment cabinet.

Install all conduits, condulets, and attachments to equipment cabinets in a manner that preserves the minimum bending radius of cables and creates waterproof connections and seals.

Install a UPS in each cabinet and power all CCTV and communications equipment from the UPS.

23.4. MEASUREMENT AND PAYMENT

Field equipment cabinet will be measured and paid as the actual number of CCTV equipment cabinets furnished, installed and accepted.

No payment will be made for the UPS, cabling, connectors, cabinet attachment assemblies, conduit, condulets, risers, grounding equipment, surge protectors, or any other equipment or labor required to install the field equipment cabinet and integrate the cabinets with the CCTV equipment.

Payment will be made under:

Table with 2 columns: Pay Item, Pay Unit. Row: Field Equipment CabinetEach

24. CCTV WOOD POLE

24.1. DESCRIPTION

Furnish and install wood poles, grounding systems and all necessary hardware for CCTV camera installations. Reference applicable Sections of Article 1720 of the 2024 Standard Specifications for Roads and Structures for Materials and Construction.

Furnish an air terminal and lightning protection system in accordance with the "Air Terminal & Lightning Protection System" Project Special Provisions.

Furnish and install wood poles with grounding systems and all necessary hardware in accordance with Section 1720 of the 2024 Standard Specifications for Roads and Structures.

24.2. MATERIALS

Material, equipment, and hardware furnished under this section shall be pre-approved on the Department’s QPL. For Wood poles refer to Sub articles 1082-3(F) Treated Timber and Lumber – Poles and 1082-4(A) – General; 1082-4 (B) – Timber Preservatives; 1082-4(G) – Poles; in the 2024 Standard Specifications for Roads and Structures.

24.3. CCTV WOOD POLE

Unless otherwise specified in the Plans, furnish Class 3 or better wood poles that are a minimum of 60’ long to permit the CCTV camera to be mounted approximately 45 feet above the ground and a minimum 5 feet from the top of the pole.

24.4. CONSTRUCTION METHODS

Mark final pole locations and receive approval from the Engineer before installing poles. Comply with all requirements of Section 1720-3 of the 2024 Standard Specifications for Roads and Structures.

Install the required Air Terminal & Lightning Protection System as described in the Air Terminal & Lighting Protection Specifications and as referenced in the following Typical Details:

- CCTV Camera Installation for Wood Pole with Aerial Electrical Service
- CCTV Camera Installation for Wood Pole with Underground Electrical Service

24.5. MEASUREMENT AND PAYMENT

CCTV Wood Pole will be measured and paid as the actual number of wood poles for CCTV camera furnished, installed and accepted.

No measurement will be made for equipment, labor and materials, to install the wood pole as these items of work will be incidental to furnishing and installing CCTV wood poles.

No measurement will be made for furnishing and installing the “Air Terminal and Lightning Protection System” as this will be considered incidental to the “CCTV Wood Pole” installation.

Payment will be made under:

CCTV Wood Pole.....Each

25. AIR TERMINAL & LIGHTNING PROTECTION SYSTEM

25.1. DESCRIPTION

Furnish an air terminal and lightning protection system that is comprised of items meeting UL 96 and UL 467 product standards for lightning protection and installed to be compliant with the National Fire Protection Association 780 Standards for Lightning Protection Systems. The lightning protection system shall consist of, as a minimum, an Air Terminal, vertical Air Terminal Base (wood pole) or Air Terminal Rod Clamps (metal pole), 28-Strand bare-copper lightning conductor, 4-point grounding systems (grounding electrodes), #4 AWG copper bonding conductors, marker tape and other miscellaneous hardware.

25.2. Materials

A. General

Reference the following Typical Details where applicable:

- CCTV Camera Installation for Metal Pole with Aerial Electrical Service
- CCTV Camera Installation for Metal Pole with Underground Electrical Service
- CCTV Camera Installation for Wood Pole with Aerial Electrical Service
- CCTV Camera Installation for Wood Pole with Underground Electrical Service

B. Wood Pole

Furnish a UL Listed Class II, copper clad minimum 48" long by ½" diameter air terminal. Ensure the air terminal has a tapered tip with a rounded point on one end and is threaded on the connection end with standard Unified Coarse (UNC) 13 threads per inch.

Furnish a copper vertical air terminal base that has internal threading to accept a ½" diameter air terminal with UNC 13 threads per inch. Provide a base that allows for a minimum ¼" mounting hole to secure the base to the vertical side of a wood pole. Ensure the air terminal base includes (2) 5/16" cap screws to secure the bare copper lightning conductor. Additionally, provide (2) ½" copper tube straps (conduit clamps) to secure the air terminal and bare copper lightning conductor to the pole.

C. Metal Pole

Furnish a UL Listed Class II, stainless steel minimum 48" long by ½" diameter air terminal with a tapered tip with a rounded point on one end. No threading is required on the opposing end.

Furnish an air terminal rod clamp manufactured out of 304 stainless steel. Ensure the air terminal rod clamp has two horizontal support arms that are 2" wide by 3/16" thick and design to offset the air terminal approximately 8" away from the metal pole. Ensure the support arms at the point where the air terminal is to be installed has an internal crease to secure the air terminal along with four (4) bolts to provide the clamping action between the two support arms. Provide two (2) stainless steel banding clamps to secure the air terminal rod clamp's base plate to the metal pole.

D. Copper Lightning Conductor and Ground Rods

Furnish a Class II rated copper lightning conductor which consists of 28 strands (minimum) of 15 AWG copper wires to form a rope-lay bare copper lightning conductor. Furnish 5/8" diameter, 10-foot-long copper-clad steel ground rods with a 10-mil thick copper cladding to serve as an integral part of the 4-point grounding system. Furnish irreversible mechanical clamps to secure the 28-strand lightning conductor, #4 AWG bare copper ground wires and grounding electrodes together to complete the grounding system.

25.3. Construction Methods

A. Wood Pole

Install the vertical air terminal base approximately 12" below the top of the wood pole and install the air terminal to the threaded connection on the base. Install a ½" copper tube strap (conduit clamp) over the air terminal, 6" from the top of the pole. Additionally, secure the copper lightning conductor under both 5/16" diameter cap screws located on the base. Install an additional ½" copper tube strap (conduit clamp) over the bare copper lightning conductor, 6" below the air terminal base. Locate the ¼" mounting hole on the vertical air terminal base and install a ¼" by 3" (minimum) long lag bolt through the base and into the wood pole to support the air terminal assembly.

Route the bare copper lightning conductor to maintain maximum horizontal separation from any risers that traverse up the pole. Secure the bare copper lightning conductor to the pole on 24" centers using copper cable clips. From the bottom of the pole (ground level) install a 2" by 10' long PVC U-Guard over the bare copper lightning conductor to protect the cable from vandalism.

B. Metal Pole

Install two (2) stainless steel air terminal rod clamps to the side of the metal pole structure starting at 6” below the top of the pole with the second air terminal clamp 12” from the top of the pole (approximately 6” of separation between the 2 clamps). Secure each air terminal rod clamp to the pole structure with two (2) stainless steel banding clamps. Install the air terminal between the horizontal support arms on each air terminal rod clamp and tighten the bolts to provide a secure connection.

C. Copper Lightning Conductor and Ground Rods

Install the 4-point grounding system by installing a central grounding electrode that is surrounded by a minimum of three (3) additional grounding electrodes spaced approximately 20 feet away from the central grounding electrode and approximately 120 degrees apart. Interconnect each grounding electrode using a #4 AWG bare copper conductor back to the central grounding electrode using irreversible mechanical crimps. Additionally, using an irreversible mechanical crimp, connect the bare copper lightning conductor to the central grounding electrode. Install each grounding electrode and its corresponding #4 AWG bare copper grounding wire and 28 strand copper lightning conductor such that the wires are 24” below grade. Install marker tape 12” below grade and above all grounding conductors.

In instances where right-of-way does not allow for ground rod spacing as required above, reference the 2024 Roadway Standard Drawings - Section 1700.02 “Electrical Service Grounding” for “Limited Shoulder” or “Restricted Space” installation alternatives.

Prior to connecting the lightning protection system to an electrical service, perform a grounding electrode test on the lightning protection system to obtain a maximum of 20 ohms or less. Install additional grounding electrodes as need to obtain the 20 ohms or less requirement. The grounding electrode resistance test shall be verified or witnessed by the Engineer or the Engineer’s designated representative.

Follow test equipment’s procedures for measuring grounding electrode resistance. When using clamp-type ground resistance meters, readings of less than one ohm typically indicate a ground loop. Rework bonding and grounding circuits as necessary to remove ground loop circuits and retest. If a ground loop cannot be identified and removed to allow the proper use of a clamp-type ground resistance meter, use the three-point test method. Submit a completed inductive Loop & Grounding Test Form available on the Department’s website.

25.4. Measurement and Payment

No measurement will be made for furnishing and installing the “Air Terminal and Lightning Protection System” as this will be considered incidental to “CCTV Metal Pole” & “CCTV Wood Pole” installations.

26. CCTV CAMERA LOWERING SYSTEM**26.1. DESCRIPTION**

Provide a CCTV lowering system for a digital CCTV camera as an integral part of the CCTV metal pole. The lowering system will consist of a support arm, camera connection unit, internal lowering system and winch cable, metal frame with winch, and all necessary cabling and wiring for installation. The camera connection unit serves a dual role as it identifies the mechanical point where the unit attaches and detaches to the support arm to carry the CCTV camera and where PoE cable connections occur. The camera connection unit is made up of two halves, the upper half is

permanently affixed to the support arm and the lower halve is affixed to the CCTV for lowering and raising operations.

Provide a portable metal frame and winch assembly to facilitate raising and lowering of the CCTV Camera.

Ensure that all exposed components of the lowering system (support arm, camera connection unit) are made of corrosion-resistant materials that are powder-coated or galvanized or otherwise protected from the environment by industry-accepted coatings that withstand exposure to the environment. Ensure the internal components of the camera connection unit (PoE cable interface and locking/latching mechanism) are protected from exposure to external environmental conditions (rain, snow, ice, and UV) by an outer covering or shield made of aluminum or other acceptable materials.

26.2. MATERIALS

A. Winch Cable

The winch cable shall be a minimum diameter of 0.125 inch and constructed of a minimum of 7 strands, 19-gauge, stainless-steel aircraft cable with a minimum breaking strength of 1,740 pounds. Provide materials as recommend by the Manufacturer to connect one end of the winch cable to the lower halve of the camera connection unit, on the opposite end provide a quick release cable connect loop.

Ensure the stainless-steel winch cable when installed will not flex and twist and ensure that only the winch cable will be in motion inside the metal pole when the lowering device is operated. Provide a bracket inside the lower position of the pole to secure the loose end of the winch cable when not in use. Ensure that all other cables remain stable and secure during lowering and raising operations.

B. Camera Connection Unit

Camera Connection Unit (Electrical):

Ensure that the camera connection unit makes accommodations for an internal PoE connection between the cabinet and the equipment installed at the support arm. Internal PoE connection shall be terminated with a RJ45 connector at the PoE injector in the CCTV cabinet. Ensure the lowering system and its camera wiring connection system are designed so that no degradation in functionality of the cameras overall performance is affected when the CCTV camera is installed and operational. Ensure that the camera connection unit design ensures proper alignment of the PoE cable conductors when the CCTV Camera is being lifted into place.

As an integral part of the camera connection unit, provide molded electrical terminal block halves equipped with modular, self-aligning and self-adjusting female and male socket contacts. The molded electrical terminal block halves must be equipped with sufficient contacts to permit operation of all required functions of the camera.

The female socket contacts and the male contact halves must be of heavy-duty construction and the connector blocks made of molded synthetic rubber, molded chlorosulfonated polyethylene, polymer body or approved equal. The connector pins shall be made of brass or gold-plated nickel, or gold-plated copper. The current-carrying male and female contacts shall have a minimum diameter of 0.09 inch.

Provide cored holes in the molded electrical terminal block halves to create moisture-tight seals when mated. All wire leads from both the male and female contacts shall be permanently molded in a body of chlorosulfonated polyethylene, or an approved equivalent. All contacts shall be self-wiping with a shoulder at the base of each male contact so that it recesses in the female block,

thereby giving each contact a rain-tight seal when mated. The molded electrical terminal block halves shall be rated to carry the full amperage load of the camera. Upon request by the Engineer, submit documentation showing pin assignments and verification that the molded electrical terminal block halves are design sufficiently to withstand continuous operation of the camera at full load conditions.

Camera Connection Unit (Mechanical)

Ensure the camera connection unit has a minimum load capacity of 200 pounds with a 4:1 safety factor. Fixed and movable components of the camera connection unit must have a mechanical locking mechanism which automatically locks and unlocks the physical connections when engaging or disengaging the two halves. Provide a minimum of two mechanical latches for the movable assembly and, when latched, ensure that all weight is removed from the winch cable. Provide the upper half of the unit with a heavy-duty tracking guide and a means to control the latching operation in the same position each time.

Fabricate the camera connection unit to allow the winch cable to pass through itself at the point where the upper half connects with the lower half. Ensure the assembly provides an internal guide to ensure the lowering cable does not scrub against the molded electrical termination block and cannot come entangled with the mechanical locking mechanisms of the unit.

For lowering of the CCTV Camera design the locking system such that by first tightening the winch cable it will allow the latching arms to re-set into a static state so that when the winch is reversed it will cause the locking arms to release so that the CCTV Camera can be lowered. For raising of the CCTV Camera design the locking system such that by first tightening the winch cable it will allow the latching arms to re-set into a static state so that when the winch is reversed it will cause the locking arms to engage so that the CCTV Camera will be supported in its operational state. When the CCTV Camera is in its operational state, ensure that all weight and pulling forces are removed from the winch cable. Design the unit with a tracking guide pin to align the bottom moving half with the top stationary half to ensure proper alignment of the connector pins and mechanical locking features of the unit.

Provide a protective shell around the Camera Connection Unit constructed of aluminum or other approved materials.

C. Metal Frame and Winch Assembly

Provide a portable metal-frame with winch assembly that can be temporarily fasten and secured to the pole structure and connected to the winch cable to facilitate lowering and raising of the CCTV Camera. Ensure the metal frame and winch's combined weight is less than 35 pounds. Provide a quick release cable connector to secure the winch cables to one another. Ensure the winch is of a design that includes an adjustable safety clutch that incorporates a positive braking mechanism to secure the cable reel during raising and lowering operations to prevent freewheeling and has gearing that reduces the manual effort required to operate the manual lifting handle (handle crank) to raise and lower the load.

The physical process of lowering or raising the CCTV Camera shall be accomplished through a handle crank supplied with the lowering unit or via a portable lowering device to operate the winch assembly such as a variable-speed reversible electric drill or a lowering unit with a built-in electrical motor.

All lowering equipment shall be manufactured of durable, corrosion resistant materials, powder coated, galvanized, or otherwise protected from the environment by industry-accepted coatings to withstand exposure to corrosive environment. All pulleys installed for the lowering device and

portable tool must have sealed self-lubricated bearings, oil-tight bronze bearings or sintered bronze bushings.

D. Variable Speed Drill

Furnish a half-inch chuck, variable-speed reversible industrial-duty electric drill that matches the manufacturer-recommended revolutions per minute or supply the metal frame with winch with a permanently attached 120 Volt electric motor. If required furnish an adapter to transition from hand crank operation to portable drill operation.

26.3. CONSTRUCTION METHODS

Assemble the CCTV lowering systems internal components inside the metal pole cavity, consisting of the winch cable, pulleys and other hardware. Secure the support arm to the metal pole using stainless steel bolts, washers and hardware and tightened to specifications provide by the manufacturer. Fish the winch cable through the metal pole and out the support arm and through the upper half of the connection unit and secure the winch cable to the bottom half of the connection unit. Terminate the PoE cable to the molded termination block located in the upper connection unit. Ensure that the lower half of the connection unit, with the CCTV Camera attached, aligns with the upper half of the connection unit. Ensure the completed assembly aligns correctly and that the power and PoE termination points align correctly, and that the installation will not allow the unit to twist when subject to sustained 140 MPH wind speeds.

Provide 1.25-inch-diameter PVC conduit inside the metal pole cavity and install the power and data cable. Ensure the PoE cable is supported with a strain relief sleeve and routed in such a manner that it will not come into contact with the winch cable and its pulley system once installed.

26.4. MEASUREMENT AND PAYMENT

CCTV Camera Lowering System will be measured and paid as the actual number of CCTV Camera Lowering Systems furnished, installed, integrated and accepted.

Variable Speed Drill will be measured and paid as the actual number of Variable Speed Drills furnished, installed and accepted.

No payment will be made for PVC conduits installed inside the CCTV Pole, winch cable, metal frame and winch assembly, camera connection unit, support sleeves, pulley and any other hardware as these will be considered incidental to furnishing and installing a CCTV Camera lowering System.

Payment will be made under:

CCTV Camera Lowering System	Each
Variable Speed Drill	Each

27. DYNAMIC MESSAGE SIGN (DMS)

27.1. DESCRIPTION

To ensure compatibility with the existing DMS Control Software deployed in the State, furnish NTCIP compliant DMS that are fully compatible with the current control software in use by the Department. (also referred to hereinafter as the "Control Software"). Contact the engineer to inquire about the current version being used.

Furnish and install DMS compliant with UL standards 48, 50 and 879.

Furnish, install, test, integrate and make fully operational the new DMS at locations shown in the Project Plans.

Furnish operating Dynamic Message Signs, not limited to, the following types. Dimensions represent DMS sizes commonly used by the Department, other size DMS may be specified in the project plans.

DMS Naming Convention	
Type	Color
Type 1 – Front Access	A – Amber – 66mm
Type 2 – Walk-in	C – Full Color – 20mm
Type 3 – Embedded	
Type 4 – Lane Control	

- **DMS Type 1A** – Front Access Amber 66mm – 27 pixels high by 60 pixels wide
 - 3 lines, 10 characters per line, using 18” high characters.
- **DMS Type 1C** – Front Access Full Color 20mm – 96 pixels high by 208 pixels wide
 - 3 lines, 11 characters per line, using 18” high characters.
- **DMS Type 2A** – Walk-in Amber 66mm – 27 pixels high by 90 pixels wide
 - 3 lines, 15 characters per line, using 18” high characters.
- **DMS Type 2C** – Walk-in Full Color 20mm – 96 pixels high by 288 pixels wide
 - 3 lines, 15 characters per line, using 18” high characters.
- **DMS Type 3A** – Embedded Front Access Tri-color 66mm – 7 pixels high by 35 pixels wide
 - 1 line, 7 characters per line, using 18” high characters.
- **DMS Type 3C** – Embedded Front Access Full Color 20mm – 24 pixels high by 160 pixels wide
 - 1 line, 8 characters per line, using 18” high characters.
- **DMS Type 4C** – Lane Control Sign Full Color 20mm – 48- or 64-pixels square
 - 48 pixels high by 48 pixels wide
 - 1 line, 2 characters per line using 18” high characters
 - 64 pixels high x 64 pixel wide
 - 2 lines, 3 characters per line using 18” high characters

Use only UL listed and approved electronic and electrical components in the DMS system.

Use only approved DMS models listed on the NCDOT Qualified Products List (QPL) at the time of construction. NCDOT Qualified Products List can be accessed via official website at <https://apps.ncdot.gov/products/qpl/>

27.2. MATERIALS

A. Environmental and Operating Requirements

Construct the DMS and DMS controller cabinet so the equipment within is protected against moisture, dust, corrosion, and vandalism. Design and construct the DMS unit for continuous usage of at least 20 years. Design the DMS system to comply with the requirements of Section 2.1 (Environmental and Operating Standards) of NEMA TS 4-2016.

B. Viewing Requirements for all DMS

Each line of text should be clearly visible and legible to a person with 20/20 corrected vision from a distance of 900 feet in advance of the DMS at an eye height of 3.5 feet along the axis.

Any line must display equally spaced and equally sized alphanumeric individual characters. Each character must be at least 18 inches in height (unless otherwise noted in the plans) and composed from a luminous dot matrix.

C. Housing Requirements for all DMS

Construct the external skin of the sign housing out of aluminum alloy 5052 H32 that is a minimum of 1/8 inches thick for all walk-in DMS and 0.090-inch-thick for all front access or embedded DMS. Ensure the interior structure is constructed of aluminum. Ensure that exterior seams and joints, except the finish coated face pieces, are continuously welded using an inert gas welding method. Ensure that no internal frame connections or external skin attachments rely upon adhesive bonding. Ensure the sign housing meets the requirements of Section 3 of NEMA TS 4-2016.

Ensure that all drain holes and other openings in the sign housing are screened to prevent the entrance of insects. Ensure that the top of the housing includes multiple steel lifting eyebolts or equivalent hoisting points. Ensure hoist points are positioned such that the sign remains level when lifted. Ensure that the hoist points and sign frame allow the sign to be shipped, handled, and installed without damage. Ensure all external assembly and mounting hardware, including but not limited to; nuts, bolts, screws, and locking washers are corrosion resistant galvanized steel and are sealed against water intrusion. Ensure all exterior housing surfaces, excluding the sign face, and all interior housing surfaces are a natural aluminum mill finish. Ensure signs are fabricated, welded, and inspected in accordance with the requirements of the current ANSI/AWS Structural Welding Code-Aluminum. Do not place a manufacturer name, logo, or other information on the front face of the DMS or shield. Do not paint the stainless-steel bolts on the Z-bar assemblies used for mounting the enclosure.

D. Housing Requirements for Walk-in type DMS

Ensure the sign housing meets the requirements of Section 3.2.8 of NEMA TS 4-2016. Stitch weld the exterior housing panel material to the internal structural members to form a unitized structure. Ensure that exterior mounting assemblies are fabricated from aluminum alloy 6061-T6 extrusions a minimum of 3/16 inches thick. Ensure housing access is provided through an access

door at each end of the sign enclosure that meets the requirements of NEMA TS 4-2016, Section 3.2.8.1. Ensure the access doors include a keyed tumbler lock and a door handle with a hasp for a padlock. Ensure the doors include a closed-cell neoprene gasket and stainless-steel hinges. Install one appropriately sized fire extinguisher within 12 inches of each maintenance door. Ensure the sign housing meets the requirements of NEMA TS 4-2016, Section 3.2.8.3 for service lighting. All service lighting should be LED, incandescent and fluorescent lamps are not permitted. Ensure that the sign housing includes LED emergency lighting that automatically illuminates the interior when the door is open in the event of a power outage. Emergency lighting must be capable of operation without power for at least 90 minutes. Ensure the sign housing meets the requirements of NEMA TS 4-2016, Section 3.2.9 for convenience outlets.

E. Housing Requirements for Front Access DMS

Comply with the requirements of Section 3.2.5 and 3.2.6 of NEMA TS 4-2016 as it applies to front access enclosures. The following requirements complement TS 4-2016. Ensure access door does not require specialized tools or excessive force to open. Provide multiple access doors that allow maintenance personnel access to 2 or 3 sign modules at a time. Vertically hinge the doors and design to swing out from the face to provide access to the enclosure interior. Extend each door the full height of the display matrix. Provide a retaining latch mechanism for each door to hold the door open at a 90-degree angle. Each door will form the face panel for a section of the sign. Mount the LED modules to the door such that they can be removed from the door when in the open position. Other sign components can be located inside the sign enclosure and be accessible through the door opening. Provide for each door a minimum of two (2) screw-type captive latches to lock them in the closed position and pull the door tight and compress a gasket located around the perimeter of each door. Install the gasket around the doors to prevent water from entering the cabinet.

F. Housing Face Requirements for all DMS

Ensure the sign face meets the requirements of NEMA TS 4-2016, Section 3.1.3. Protect the DMS face with contiguous, weather-tight, removable panels. The DMS front face shall be constructed with multiple rigid panels, each of which supports and protects a full-height section of the LED display matrix. The panels shall be fabricated using aluminum sheeting on the exterior and polycarbonate sheeting on the interior of the panel. These panels must be a polycarbonate material that is ultraviolet protected and have an antireflection coating. Prime and coat the front side of the aluminum mask, which faces the viewing motorists, with automotive-grade semi-gloss black acrylic enamel paint or an approved equivalent. Guarantee all painted surfaces provide a minimum outdoor service life of 20 years. Design the panels so they will not warp nor reduce the legibility of the characters. Differential expansion of the DMS housing and the front panel must not cause damage to any DMS component or allow openings for moisture or dust. Glare from sunlight, roadway lighting, commercial lighting, or vehicle headlights must not reduce the legibility or visibility of the DMS. Install the panels so that a maintenance person can easily remove or open them for cleaning.

G. Housing Face Requirements for Walk-in type DMS

No exposed fasteners are allowed on the housing face. Ensure that display modules can be easily and rapidly removed from within the sign without disturbing adjacent display modules.

H. Housing Face Requirements for Front Access type DMS

The DMS front face shall be constructed with multiple vertically hinged rigid door panels, each of which contains a full-height section of the LED display matrix.

Any exposed fasteners on the housing face must be the same color and finish as the housing face. Only captive fasteners may be used on the housing face.

I. Housing Face Requirements for Embedded Front Access type DMS

The DMS front face shall be constructed with a single, horizontally hinged rigid face panel which contains a full-height section of the LED display matrix.

Any exposed fasteners on the housing face must be the same color and finish as the housing face. Only captive fasteners may be used on the housing face.

J. Sign Housing Ventilation System for all DMS

Install a minimum of one (1) temperature sensor that is mounted near the top of the DMS interior. The sensor(s) will measure the temperature of the air in the enclosure over a minimum range of -40°F to +176°F. Ensure the DMS controller will continuously monitor the internal temperature sensor output and report to the DMS control software upon request.

Design the DMS with systems for enclosure ventilation, face panel fog and frost prevention, and safe over-temperature shutdown.

Design the DMS ventilation system to be thermostatically controlled and to keep the internal DMS air temperature lower than +140°F, when the outdoor ambient temperature is +115°F or less.

The ventilation system will consist of two or more air intake ports located near the bottom of the DMS rear wall. Cover each intake port with a filter that removes airborne particles measuring 500 microns in diameter and larger. Mount one or more ventilation fans at each intake port. These fans will positively pressure the DMS enclosure.

Design the ventilation fans and air filters to be removable and replaceable from inside the DMS housing. To ease serviceability, mount the ventilation fans no more than four (4) feet from the floor of the DMS enclosure. Position ventilation fans so they do not prevent removal of an LED pixel board or driver board.

Provide each ventilation fan with a sensor to monitor its rotational speed, measured in revolutions per minute and report this speed to the sign controller upon request.

The ventilation system will move air across the rear of the LED modules in a manner such that heat is dissipated from the LED's. Design the airflow system to move air from the bottom of the enclosure towards the top to work with natural convection to move heat away from the modules.

Install each exhaust port near the top of the rear DMS wall. Provide one exhaust port for each air intake port. Screen all exhaust port openings to prevent the entrance of insects and small animals.

Cover each air intake and exhaust port with an aluminum hood attached to the rear wall of the DMS. Thoroughly seal all intakes and exhaust hoods to prevent water from entering the DMS. Provide a thermostat near the top of the DMS interior to control the activation of the ventilation system.

The DMS shall automatically shut down the LED modules to prevent damaging the LEDs if the measured internal enclosure air temperature exceeds a maximum threshold temperature. The threshold temperature shall be configurable and shall have a default factory setting of 140°F. The DMS provide an output to the controller to notify the Control Software when the DMS shuts down due to high temperature.

K. Sign Housing Ventilation System for Walk-in DMS

Ensure the sign includes a fail-safe ventilation subsystem that includes a snap disk thermostat that is independent of the sign controller. Preset the thermostat at 140°F. If the sign housing's interior reaches 140°F, the thermostat must override the normal ventilation system, bypassing the sign controller and turning on all fans. The fans must remain on until the internal sign housing temperature falls below 115°F.

L. Sign Housing Photoelectric sensors

Install three photoelectric sensors with ½ inch minimum diameter photosensitive lens inside the DMS enclosure. Use sensors that will operate normally despite continual exposure to direct sunlight. Place the sensors so they are accessible and field adjustable. Point one sensor north or bottom of the sign. Place the other two, one on the back wall and one on the front wall of the sign enclosure. Alternate designs maybe accepted, provided the sensor assemblies that are accessible and serviceable from inside the sign enclosure.

Provide controls so that the Engineer can field adjust the following:

- The light level emitted by the pixels in each Light Level Mode,
- The ambient light level at which each Light Level Mode is activated.

M. Display Modules

Manufacture each display module with a standard number of pixels which can be easily removed. Assemble the modules onto the DMS assemblies contiguously to form a continuous matrix to display the required number of lines, characters, and character height.

Design display modules that are interchangeable, self-addressable, and replaceable without using special tools. Provide plug-in type power and communication cables to connect to a display module. Ensure that the sign has a full matrix display area as defined in NEMA TS 4-2016, Section 1.6.

Design each module to display:

- All upper- and lower-case letters,
- All punctuation marks,
- All numerals 0 to 9,
- Special user-created characters or images.

Display upper-case letters and numerals over the complete height of the module. Optimize the LED grouping and mounting angle within a pixel for maximum readability.

Furnish two (2) spare display modules per each DMS installed for emergency restoration.

N. Discrete LEDs

Provide discrete LEDs with a nominal viewing cone of 30 degrees with a half-power angle of 15 degrees measured from the longitudinal axis of the LED. Make certain, the viewing cone tolerances are as specified in the LED manufacturer's product specifications and do not exceed +/- 3 degrees half-power viewing angle of 30 degrees.

Provide LEDs that are untinted, non-diffused, high output solid state lamps utilizing AlInGaP technology for Red and InGaN technology for Green and Blue. No substitutions will be allowed. Provide LEDs that emit a full color.

Provide LEDs with a MTBF (Mean Time Before Failure) of at least 100,000 hours of permanent use at an operating point of 140° F or below at a specific forward current of 20mA. Discrete LED failure is defined as the point at which the LED's luminous intensity has degraded to 50% or less of its original level.

Obtain the LEDs used in the display from a single LED manufacturer. Obtain them from batches sorted for luminous output, where the highest luminosity LED is not more than fifty percent more luminous than the lowest luminosity LED when the LEDs are driven at the same forward current. Do not use more than two successive and overlapping batches in the LED display.

Individually mount the LEDs on circuit boards that are at least 1/16" thick FR-4 fiberglass, flat black printed circuit board in a manner that promotes cooling. Protect all exposed metal on both sides of the LED pixel board (except the power connector) from water and humidity exposure by a thorough application of acrylic conformal coating. Design the boards so bench level repairs to individual pixels, including discrete LED replacement and conformal coating repair is possible.

Operate the LED display at a low internal DC voltage not to exceed 24 Volts.

Design the LED display operating range to be -20° F to +140° F at 95% relative humidity, non-condensing.

Supply the LED manufacturer's technical specification sheet with the material submittals.

O. LED Power Supplies

Power the LED Display by means of multiple regulated switching DC power supplies that operate from 120 volts AC input power and have an output of 24 volts DC or less. Wire the power supplies in a redundant parallel configuration that uses multiple power supplies per display. Provide the power supplies with current sharing capability that allows equal amounts of current to their portion of the LED display. Provide power supplies rated such that if one supply fails the remaining supplies will be able to operate their portion of the display under full load conditions (i.e. all pixels on at maximum brightness) and at a temperature of 140° F.

Provide power supplies to operate within a minimum input voltage range of +90 to +135 volts AC and within a temperature range of -22° F to 140° F. Power supply output at 140° F must not deteriorate to less than 65% of its specified output at 70° F. Provide power supplies that are overload protected by means of circuit breakers, that have an efficiency rating of at least 75%, a power factor rating of at least .95, and are UL listed. Provide all power supplies from the same manufacturer and with the same model number for each Type of DMS. Design the power driver circuitry to minimize power consumption.

Design the field controller to monitor the operational status (normal or failed) of each individual power supply and be able to display this information on the Client Computer screen graphically. Color code power supply status, red for failed and green for normal. Provide power supply monitoring circuitry to detect power failure in the DMS and to automatically report this fault to the Control Software. This requirement is in addition to reporting power failure at the controller cabinet.

P. LED Pixels

A pixel is defined as the smallest programmable portion of a display module that consists of a cluster of closely spaced discrete LEDs. Design each pixel with either 66mm or 20mm spacing depending on the type of DMS called for in the plans.

Construct the pixels with strings of LEDs. It is the manufacturer's responsibility to determine the number of LEDs in each string to produce the candela requirement as stated herein.

Use continuous current to drive the LEDs at the maximum brightness level. Design the light levels to be adjustable for each DMS / controller so the Engineer may set levels to match the luminance requirements at each installation site.

Ensure each pixel produces a luminous intensity of 40 Cd when driven with an LED drive current of 20 mA per string.

Power the LEDs in each pixel in strings. Use a redundant design so that the failure of an LED in one string does not affect the operation of any other string within the pixel and does not lower the luminous intensity of the pixel more than 25% of the 40Cd requirement. Provide the sign controller with the ability to detect the failure of any LED string and identify which LED string has failed.

Q. DMS Mini Controller

For Walk-In and Front Access DMS Types only, furnish and install a mini controller inside the DMS that is interconnected with the main controller using a fiber-optic cable. The mini controller will enable a technician to perform all functions available from the main controller. Provide the mini controller with a Display and keypad interface. Size the display screen to allow preview of an entire one-page message on one screen. Provide a 4 X 4 keypad.

R. DMS Enclosure Structure Mounting

Mount the DMS enclosure and interconnect system securely to the supporting structures. Design the DMS enclosure supports and structure to allow full access to the DMS enclosure inspection door. Mount the DMS enclosure according to the manufacturer's recommendations.

Furnish and install U-bolt connections of hanger beams to truss chords with a double nut at each end of the U-bolt. Bring the double nuts tight against each other by the use of two wrenches.

Submit plans for the DMS enclosure, structure, mounting description and calculations to the Engineer for approval. Have such calculations and drawings approved by a Professional Engineer registered in the state of North Carolina, and bear his signature, seal, and date of acceptance.

Provide removable lifting eyes or the equivalent on the DMS enclosure rated for its total weight to facilitate handling and mounting the DMS enclosure.

Design the DMS structure to conform to the applicable requirements of Section 906 of the *2024 Standard Specifications for Roads and Structures* and the section titled "DMS Pedestal Structure" of these Project Special Provisions.

S. DMS / DMS Controller Interconnect

Furnish and install all necessary cabling, conduit, and terminal blocks to connect the DMS and the DMS controller located in the equipment cabinet. Use approved manufacturer's specifications and the Project Plans for cable and conduit types and sizes. Use fiber-optic cable to interconnect sign and

controller. Install fiber-optic interconnect centers in the sign enclosure and cabinet to securely install and terminate the fiber-optic cable. Submit material submittal cut sheets for the interconnect center.

T. DMS Controller and DMS Cabinet

Furnish and install one DMS controller with accessories per DMS in a protective cabinet. Controlling multiple DMS with one controller is allowed when multiple DMS are mounted on the same structure. Mount the controller cabinet on the Sign support structure. Install cabinet so that the height from the ground to the middle of the cabinet is 4 feet. Ensure a minimum of 24" x 36" level concrete working surface under each cabinet that provides maintenance technicians with a safe working environment.

Provide the DMS controller as a software-oriented microprocessor and with resident software stored in non-volatile memory. The Control Software, controller and communications must comply with the NTCIP Standards identified in these Project Special Provisions. Provide sufficient non-volatile memory to allow storage of at least 500 multi-page messages and a test pattern program.

For DMS Type 4C installations provide a single controller that can control up to eight (8) signs simultaneously.

Furnish the controller cabinet with, but not limited to, the following:

- Power supply and distribution assemblies,
- Power line filtering hybrid surge protectors,
- Radio Interference Suppressor,
- Communications surge protection devices,
- Industrial-Grade UPS system and local disconnect,
- Microprocessor based controller,
- Display driver and control system (unless integral to the DMS),
- RJ45 Ethernet interface port,
- Local user interface,
- Interior lighting and duplex receptacle,
- Adjustable shelves as required for components,
- Temperature control system,
- All interconnect harnesses, connectors, and terminal blocks,
- All necessary installation and mounting hardware.

Furnish the DMS controller and associated equipment completely housed in a Caltrans 336S cabinet made from 5052 H32 sheet aluminum at least 1/8" thick. Use natural aluminum cabinets. Perform all welding of aluminum and aluminum alloys in accordance with the latest edition of AWS D1.2, Structural Welding Code – Aluminum. Continuously weld the seams using Gas Metal Arc Welding (GMAW).

Slant the cabinet roof away from the front of the cabinet to prevent water from collecting on it.

Do not place a manufacturer name, logo, or other information on the faces of the controller cabinet

Provide cabinets capable of housing the components and sized to fit space requirement. Design the cabinet layout for ease of maintenance and operation, with all components easily accessible. Submit a cabinet layout plan for approval by the Engineer.

Locate louvered vents with filters in the cabinet to direct airflow over the controller and auxiliary equipment, and in a manner that prevents rain from entering the cabinet. Fit the inside of the cabinet, directly behind the vents, with a replaceable, standard size, commercially available air filter of sufficient size to cover the entire vented area.

Provide a torsionally rigid door with a continuous stainless-steel hinge on the side that permits complete access to the cabinet interior. Provide a gasket as a permanent and weather resistant seal at the cabinet door and at the edges of the fan / exhaust openings. Use a non-absorbent gasket material that will maintain its resiliency after long term exposure to the outdoor environment. Construct the doors so that they fit firmly and evenly against the gasket material when closed. Provide the cabinet door with louvered vents and air filters near the bottom as described in the paragraph above.

The cabinet shall contain a full-height standard EIA 19-inch rack. The rack shall be secured within the cabinet by mounts at the top and bottom.

The rack shall contain a minimum of one (1) pullout drawer. The drawer shall be suitable for storing manuals and small tools. The drawer shall be able to latch in the out position to function as a laptop/utility shelf.

Provide a convenient location on the inside of the door to store the cabinet wiring diagrams and other related cabinet drawings. Provide a Corbin #2 main door lock made of non-ferrous or stainless-steel material. Key all locks on the project alike and provide 1 key per lock to the Engineer. In addition, design the handle to permit padlocking.

Provide the interior of the cabinet with ample space for housing the controller and all associated equipment and wiring. Provide ample space in the bottom of the cabinet for the entrance and exit of all power, communications, and grounding conductors and conduit.

Arrange the equipment to permit easy installation of the cabling through the conduit so that they will not interfere with the operation, inspection, or maintenance of the unit. Provide adjustable metal shelves, brackets, or other support for the controller unit and auxiliary equipment. Leave a 3-inch minimum clearance from the bottom of the cabinet to all equipment, terminals, and bus bars.

Provide power supply monitoring circuitry to detect power failure and to automatically report the occurrence to the Control Software.

Install two LED light strips with shields, one in the top of the cabinet and the other under the bottom shelf. Design both lights to automatically turn on when the cabinet door is opened and turn off when the door closes.

Mount and wire a 120V (+10%) GFCI duplex receptacle of the 3-wire grounding type in the cabinet in a location that presents no electrical hazard when used by service personnel for the operation of power tools and work lights.

No cabinet resident equipment may utilize the GFCI receptacle. Furnish one spare non-GFCI duplex receptacle for future equipment.

Mount a bug-proof and weatherproof thermostatically controlled fan and safety shield in the top of the cabinet. Size the fan to provide at least for two air exchanges per minute. Fuse the fan at 125% of the capacity of the motor. The magnetic field of the fan motor must not affect the performance of the control equipment. Use a fan thermostat that is manually adjustable to turn on between 80° F and 160° F with a differential of not more than 10° F between automatic turn on and turn off. Mount it in an easily accessible location, but not within 6 Inches of the fan.

Install additional fans and/or heaters as needed to maintain the temperature inside the cabinet within the operating temperature range of the equipment within the cabinet as recommended by equipment manufacturer(s).

1. Wiring

The requirements stated herein apply wherever electrical wiring is needed for any DMS system assemblies and subassemblies such as controller cabinet, DMS enclosure, electrical panel boards etc.

Neatly arrange and secure the wiring inside the cabinet. Where cable wires are clamped to the walls of the control cabinet, provide clamps made of nylon, metal, plastic with rubber or neoprene protectors, or similar. Lace and jacket all harnesses or tie them with nylon tie wraps spaced at 6 inches maximum to prevent separation of the individual conductors.

Individually and uniquely label all conductors. Ensure all conductor labels are clearly visible without moving the conductor. Connect all terminal conductors to the terminal strip in right angles. Remove excess conductor before termination of the conductor. Mold the conductor in such a fashion as to retain its relative position to the terminal strip if removed from the strip. Do not run a conductor across a work surface with the exception of connecting to that work surface. No conductor bundles can be support by fasteners that support work surfaces. Install all connectors, devices and conductors in accordance to manufactures guidelines. Comply with the latest NEC guideline in effect during installation. No conductor or conductor bundle may hang loose or create a snag hazard. Protect all conductors from damage. Ensure all solder joints are completed using industry accepted practices and will not fail due to vibration or movement. Protect lamps and control boards from damage.

No splicing will be allowed for feeder conductors and communication cables from the equipment cabinet to the DMS enclosure.

Insulate all conductors and live terminals so they are not hazardous to maintenance personnel.

Route and bundle all wiring containing line voltage AC and / or shield it from all low voltage control circuits. Install safety covers to prevent accidental contact with all live AC terminals located inside the cabinet.

Use industry standard, keyed type connectors with a retaining feature for connections to the controller.

Label all equipment and equipment controls clearly.

Supply each cabinet with one complete set of wiring diagrams that identify the color-coding or wire tagging used in all connections. Furnish a water-resistant packet adequate for storing wiring diagrams, operating instructions, and maintenance manuals with each cabinet.

2. Power Supply and Circuit Protection

Design the DMS and controller for use on a system with a line voltage of 120V + 10% at a frequency of 60 Hz \pm 3 Hz. Under normal operation, do not allow the voltage drop between no load and full load of the DMS and its controller to exceed 3% of the nominal voltage.

Blackout, brownout, line noise, chronic over-voltage, sag, spike, surge, and transient effects are considered typical AC voltage defects. Protect the DMS system equipment so that these defects do not damage the DMS equipment or interrupt their operation. Equip all cabinets with devices to protect the equipment in the cabinet from damage due to lightning and external circuit power and current surges.

3. Circuit Breakers

Protect the DMS controller, accessories, and cabinet utilities with thermal magnetic circuit breakers. Provide the controller cabinet with a main circuit breaker sized according to the NEC. Use appropriately sized branch circuit breakers to protect the controller, sign display and accessories and for servicing DMS equipment and cabinet utilities.

Provide a subpanel in the sign enclosure with a main and branch circuit breakers sized appropriately per NEC.

Provide a detailed plan for power distribution within the cabinet and the sign. Label all breaker and conductor with size and loads. Have the plans signed and sealed by a NC registered PE and submit the plans for review and approval.

4. Surge Suppressor

Install and clearly label filtering hybrid power line surge protectors on the load side of the branch circuit breakers in a manner that permits easy servicing. Ground and electrically bond the surge protector to the cabinet within 2 inches.

Provide power line surge protector that meets the following requirements:

Peak surge current occurrences	20 minimum
Peak surge current for an 8 x 20 microsecond waveshape	50,000 Amperes
Energy Absorption	> 500 Joules
Clamp voltage	240 Volts
Response time	<1 nanosecond
Minimum current for filtered output	15 Amperes for 120VAC*
Temperature range	-40°F to +158°F

*Capable of handling the continuous current to the equipment

5. Transients and Emissions

DMS and DMS controller will be designed in such a way to meet the latest NEMA TS-4 for Transients and Emissions.

6. Transient Protection

The RS232 and Ethernet communication ports in the DMS sign controller shall be protected with surge protection between each signal line and ground. This surge protection shall be integrated internally within the controller.

7. Lightning Arrester

Protect the system with an UL approved lightning arrester installed at the main service disconnect that meets the following requirements:

Type of design	Silicon Oxide Varistor
Voltage	120/240 Single phase, 3 wires
Maximum current	100,000 Amps
Maximum energy	3000 Joules per pole
Maximum number of surges	Unlimited
Response time one milliamp test	5 nanoseconds
Response time to clamp 10,000 amps	10 nanoseconds
Response time to clamp 50,000 amps	25 nanoseconds
Leak current at double the rated voltage	None
Ground Wire	Separate

8. Uninterruptible Power Supply (UPS)

Furnish UPS with external temperature monitoring that will shut off when running on battery power and the maximum operating temperature for the ethernet switch is reached.

Install UPS with RJ-45 ethernet network monitoring ports that can be disabled via the UPS software/firmware.

Contractor is responsible for supplying a UPS and batteries that can adequately power the cabinet load plus an additional 20% for a **minimum** of 4 hours. Contractor shall request the power requirements for any department supplied equipment prior to submitting UPS for approval. Allow eight (8) weeks for the department to supply equipment power requirements. Provide to the Engineer for Approval, a submittal package with Engineering Calculations consisting of, as a minimum, schematic drawing, technical data sheets, and supporting documentation. Ensure the documentation demonstrates, in theory, that the battery(ies) will provide for continuous operation for a minimum of four (4) consecutive hours with no additional charging.

Furnish and install one rack mounted UPS in each new cabinet that meet the following **minimum** specifications:

Output

Nominal Output Voltage	120V
Output Voltage Distortion	Less than 5% at full load

Output Frequency (sync to mains)	57 - 63 Hz for 60 Hz nominal
Crest Factor	up to 5:1
Waveform Type	Sine wave
Output Connections	(4) NEMA 5-15R

Input

Nominal Input Voltage	120V
Input Frequency	50/60 Hz +/- 3 Hz (auto sensing)
Input Connections	NEMA 5-15P
Input voltage range for main operations	82 - 144V
Input voltage adjustable range for mains operation	75 -154 V

Battery Type

Maintenance-free sealed Lead-Acid battery with suspended electrolyte, leak-proof.

Typical recharge time	2 hours
-----------------------	---------

Communications & Management

Interface Port(s)	DB-9 RS-232, USB,RJ-45 Ethernet
Control panel	LED status display with load and battery bar-graphs

Surge Protection and Filtering

Surge energy rating	480 Joules
---------------------	------------

Environmental

Operating Environment	-32 - 165 °F
Operating Relative Humidity	0 - 95%

Conformance

Regulatory Approvals	FCC Part 15 Class A, UL 1778
----------------------	------------------------------

9. Controller Communications Interface

Provide the controller with the following interface ports:

- An EIA/TIA-232E port for remote communication using NTCIP,
- An 10/100 Ethernet port for remote communication using NTCIP,
- An EIA/TIA-232E port for onsite access using a laptop,
- An EIA/TIA-232E auxiliary port for communication with a field device such as a UPS,
- Fiber-optic ports for communication with the sign,

10. Controller Local User Interface

Provide the controller with a Local User Interface (LUI) for at least the following functions:

- On / Off Switch: controls power to the controller,
- Control Mode Switch: for setting the controller operation mode to either remote or local mode,
- Display and Keypad: Allow user to navigate through the controller menu for configuration (display, communications parameter, etc.) running diagnostics, viewing peripherals status, message creation, message preview, message activation, etc. Furnish a display with a minimum size of 240x64 dots with LED back light.

Protected access to the LUI with an alphanumeric and PIN passwords. Allow the user to select a preferred method of password protection. Default and hardcoded passwords are not allowed.

11. Controller Address

Assign each DMS controller a unique address. Preface all commands from the Control Software with a particular DMS controller address. The DMS controller compares its address with the address transmitted; if the addresses match, then the controller processes the accompanying data.

12. Controller Functions

Design the DMS controller to continuously control and monitor the DMS independent of the Control Software. Design the controller to display a message on the sign sent by the Control Software, a message stored in the sign controller memory, or a message created on site by an operator using the controller keypad.

Provide the DMS controller with a watchdog timer to detect controller failures and to reset the microprocessor, and with a battery backed up clock to maintain an accurate time and date reference. Set the clock through an external command from the Control Software or the Local User Interface.

13. DMS Controller Memory

Furnish each DMS controller with non-volatile memory. Use the non-volatile memory to store and reprogram at least one test pattern sequence and 500 messages containing a minimum of two pages of 45 characters per page. The Control Software can upload messages into and download messages from each controller's non-volatile memory remotely.

Messages uploaded and stored in the controller's non-volatile memory may be erased and edited using the Control Software and the controller. New messages may be uploaded to and stored in the controller's non-volatile memory using the Control Software and the controller.

U. Equipment List

Provide a general description of all equipment and all information necessary to describe the basic use or function of the major system components. Include a general "block diagram" presentation. Include tabular charts listing auxiliary equipment, if any is required. Include the nomenclature, physical and electrical characteristics, and functions of the auxiliary equipment unless such

information is contained in an associated manual; in this case include a reference to the location of the information.

Include a table itemizing the estimated average and maximum power consumption for each major piece of equipment.

V. Physical Description

Provide a detailed physical description of size, weight, center of gravity, special mounting requirements, electrical connections, and all other pertinent information necessary for proper installation and operation of the equipment.

W. Parts List

Submit a parts list that contains all information needed to describe the characteristics of the individual parts, as required for identification to the Engineer. Include a list of all equipment within a group and a list of all assemblies, sub-assemblies, and replacement parts of all units. Arrange this data in a table, in alpha numerical order of the schematic reference symbols, which gives the associated description, manufacture's name, and part number, as well as alternate manufacturers and part numbers. Provide a table of contents or other appropriate grouping to identify major components, assemblies, etc.

X. Character Set Submittal

Submit an engineering drawing of the DMS character set including at a minimum, 26 upper case and lower case letters, 10 numerals, 9 punctuation marks (. , ! ? - ' " ; :) 12 special characters (# & * + / () [] < > @) and arrows at 0, 45, 90, 135, 180, 225, 270, and 315 degrees.

Y. Wiring Diagrams

Submit a wiring diagram for each DMS and each controller cabinet, as well as interconnection wiring diagrams for the system as a whole to the Engineer.

Z. Routine of Operation

Describe the operational routine, from necessary preparations for placing the equipment into operation to securing the equipment after operation. Show appropriate illustrations with the sequence of operations presented in tabular form wherever applicable. Include in this section a total list of the test instruments, aids and tools required to perform necessary measurements and measurement techniques for each component, as well as set up, test, and calibration procedures.

AA. Maintenance Procedures

Specify and submit the recommended preventative maintenance procedures and checks at pre-operation, monthly, quarterly, semiannual, annual, and "as required" periods to assure equipment

operates reliably to the Engineer. List specifications (including tolerances) for all electrical, mechanical, and other applicable measurements and / or adjustments.

BB. Repair Procedures

Include in this section all data and step by step procedures necessary to isolate and repair failures or malfunctions, assuming the maintenance technicians are capable of analytical reasoning using the information provided in the sections titled “Wiring Diagrams”, “Routine of Operation” and “Maintenance Procedures”

Describe accuracy, limits, and tolerances for all electrical, physical, or other applicable measurements. Include instructions for disassembly, overhaul, and reassembly, with shop specifications and performance requirements.

Give detailed instructions only where failure to follow special procedures would result in damage to equipment, improper operation, danger to operating or maintenance personnel, etc. Include such instructions and specifications only for maintenance that specialized technicians and engineers in a modern electromechanical shop would perform. Describe special test set up, component fabrication, and the use of special tools, jigs, and test equipment.

CC. Warranty

Ensure that the DMS system and equipment has a manufacturer’s warranty covering all defects and failures for a minimum of five (5) years from the date of final acceptance by the Engineer. This warranty will cover all parts, labor, shipping, and any other costs associated with the repair of the DMS.

27.3. CONSTRUCTION METHODS

A. Description

This article establishes practices and procedures and gives minimum standards and requirements for the installation of DMS systems, auxiliary equipment and the construction of related structures.

Provide electrical equipment described in this specification that conforms to the standards of NEMA, UL, or Electronic Industries Association (EIA), wherever applicable. Provide connections between DMS equipment and DMS sign housing and electric utilities that conform to NEC standards.

Provide stainless steel screws, nuts, and locking washers in all external locations. Do not use self-tapping screws unless specifically approved by the Engineer. Use parts made of corrosion resistant materials, such as plastic, stainless steel, brass, or aluminum. Use construction materials that resist fungus growth and moisture deterioration. Separate dissimilar metals by an inert dielectric material.

B. Layout

The Regional ITS engineer or Division Traffic Engineer will establish the actual location of each DMS assembly. It is the Contractor’s responsibility to ensure proper elevation, offset, and orientation of all DMS assemblies. The location of service poles as well as conduit lengths shown in the Project

Plans, are approximate based on available project data. Make actual field measurements to place conduit and equipment at the required location.

C. Construction Submittal

When the work is complete, submit "as built" plans, inventory sheets, and any other data required by the Engineer to show the details of actual construction and installation and any modifications made during installation.

The "as built" plans will show: the DMS, controller, and service pole locations; DMS enclosure and controller cabinet wiring layouts; Wiring Diagrams, Parts list; coordinates of the DMS and devices; and wire and conduit routing. Show horizontal and vertical locations of all underground conduits and cables dimensioned from fixed objects.

Include detailed drawings that identify the routing of all conductors in the system by cable type, color code, and function. Clearly label all equipment in the DMS system, controller cabinet, and DMS enclosure.

D. Conduit

Install the conduit system in accordance with Section 1715 of the *Standard Specifications* and NEC requirements for an approved watertight raceway.

Make bends in the conduit so as not to damage it or change its internal diameter. Install watertight and continuous conduit with as few couplings as standard lengths permit.

Clean conduit before, during, and after installation. Install conduit in such a manner that temperature changes will not cause elongation or contraction that might damage the system.

Attach the conduit system to and install along the structural components of the Sign structure assemblies with beam clamps or stainless-steel strapping or inside the structure if there is available space. Install strapping according to the strapping manufacturer's recommendations and according to NEC requirements. Do not use welding or drilling to fasten conduit to structural components. Space the fasteners at no more than 4 feet for conduit 1.5 inches and larger or 6 feet for conduit smaller than 1.25 inches. Place fasteners no more than 3 feet from the center of bends, fittings, boxes, switches, and devices.

Flexible conduit will only be allowed when the conduits transition from the horizontal structure segment to the horizontal truss segment and from the horizontal truss segment to the rear entrance of the DMS when installing the DMS communications and feeder cables. The maximum length of flexible conduit allowed at each transition will be 5 feet.

Do not exceed the appropriate fill ratio on all cable installed in conduit as specified in the NEC.

E. Wiring Methods (Power)

Do not pull permanent wire through a conduit system until the system is complete and has been cleaned.

Color-code all conductors per the NEC. Use approved marking tape, paint, sleeves or continuous colored conductors for No.8 AWG and larger. Do not mark a white conductor in a cable assembly any other color.

Do not splice underground circuits unless specifically noted in the Project Plans.

F. Equipment and Cabinet Mounting

Mount equipment securely at the locations shown in the Project Plans, in conformance with the dimensions shown. Install fasteners as recommended by the manufacturer and space them evenly. Use all mounting holes and attachment points for attaching DMS enclosures and controller cabinets to the structures.

Drill holes for expansion anchors of the size recommended by the manufacturer of the anchors and thoroughly clean them of all debris.

Provide cabinets with all strapping hardware and any other necessary mounting hardware in accordance with these Project Special Provisions and the Project Plans.

Seal all unused conduit installed in cabinets at both ends to prevent water and dirt from entering the conduit and cabinet with approved sealing material.

Install a ground bushing attached inside the cabinet on all metal conduits entering the cabinet. Connect these ground bushings to the cabinet ground bus.

Install a level concrete technician pad measuring a minimum 4 inches thick, 36 inches wide and 36 inches long at the front door of the DMS equipment cabinet as shown on the Typical Details sheet within the Project Plans.

G. Work Site Clean-Up

Clean the site of all debris, excess excavation, waste packing material, wire, etc. Clean and clear the work site at the end of each workday. Do not throw waste material in storm drains or sewers.

27.4. GENERAL TEST PROCEDURE

Test the DMS and its components in a series of functional tests and ensure the results of each test meet the specified requirements in the presence of the Engineer. These tests should not damage the equipment. The Engineer will reject equipment that fails to fulfill the requirements of any test. Resubmit rejected equipment after correcting non-conformities and re-testing; completely document all diagnoses and corrective actions. Modify all equipment furnished under this contract, without additional cost to the Department, to incorporate all design changes necessary to pass the required tests.

Provide electronic copies of all test procedures and requirements to the Engineer for review and approval at least 30 days prior to the testing start date.

Only use approved procedures for the tests. Include the following in the test procedures:

- A step-by-step outline of the test sequence that demonstrates the testing of every function of the equipment or system tested

- A description of the expected nominal operation, output, and test results, and the pass / fail criteria
- An estimate of the test duration and a proposed test schedule
- A data form to record all data and quantitative results obtained during the test
- A description of any special equipment, setup, manpower, or conditions required by the test

Provide all necessary test equipment and technical support. Use test equipment calibrated to National Institute of Standards and Technology (NIST) standards. Provide calibration documentation upon request.

Conform to these testing requirements and the requirements of these specifications. It is the Contractor's responsibility to ensure the system functions properly even after the Engineer accepts the CCTV test results.

Provide electronic copies of the quantitative test results and data forms containing all data taken, highlighting any non-conforming results and remedies taken, to the Engineer for approval. An authorized representative of the manufacturer must sign the test results and data forms.

27.5. COMPATIBILITY TESTS

A. DMS System

Compatibility Tests are applicable to DMS that the Contractor wishes to furnish but are of a different manufacturer or model series than the existing units installed in the Region. If required, the Compatibility Test shall be completed and accepted by the Engineer prior to approval of the material submittal.

The Compatibility Test shall be performed in a laboratory environment at a facility chosen by the Engineer based on the type of unit being tested. Provide notice to the Engineer with the material submitted that a Compatibility Test is requested. The notice shall include a detailed test plan that will show compatibility with existing equipment. The notice shall be given a minimum of 15 calendar days prior to the beginning of the Compatibility Test.

The Contractor shall provide, install, and integrate a full-functioning unit to be tested. The Department will provide access to existing equipment to facilitate these testing procedures. The Engineer will determine if the Compatibility Test was acceptable for each proposed device. To prove compatibility the Contractor is responsible for configuring the proposed equipment at the applicable Traffic Operations Center (TOC) with the accompaniment of an approved TOC employee.

27.6. OPERATIONAL FIELD TEST (ON-SITE COMMISSIONING)

A. DMS System

Final DMS locations must be field verified and approved by the Engineer. Perform the following local operational field tests at the DMS assembly field site in accordance with the test plans in the presence of the ITS Design Unit and a representative of the DMS manufacturer. The Contractor is responsible for providing a laptop for camera control and positioning during the test. After completing the installation of the camera assemblies, including the camera hardware, power supply, and connecting cables, the contractor shall:

1. Local Field Testing

Furnish all equipment and labor necessary to test the installed camera and perform the following tests before any connections are made.

- Verify that physical construction has been completed.
- Inspect the quality and tightness of ground and surge protector connections.
- Check the power supply voltages and outputs, check connection of devices to power source.
- Verify installation of specified cables and connection between the DMS and control cabinet,
- Make sure cabinet wiring is neat and labeled properly; check wiring for any wear and tear; check for exposed or loose wires.
- Perform the DMS assembly manufacturer's initial power-on test in accordance with the manufacturer's recommendation.
- Set the DMS control address.

2. Central Operations Testing

- Interconnect the DMS's communication interface device with one of the following methods as depicted on the plans:
 - communication network's assigned Ethernet switch and assigned fiber-optic trunk cable and verify a transmit/receive LED is functioning and that the DMS is fully operational at the TOC.

AND/OR

- to the DOT furnished cellular modem and verify a transmit/receive LED is functioning and that the DMS is fully operational at the TOC.
- Review DMS date and time and DMS controller information.
- Run DMS diagnostics and review results.
- Run DMS pixel test and review results.
- Run test message.
- Run test schedule.
- Program burn-in scenario.

Approval of Operational Field Test results does not relieve the Contractor to conform to the requirements in these Project Special Provisions. If the DMS system does not pass these tests, document a correction or substitute a new unit as approved by the Engineer. Re-test the system until it passes all requirements.

27.7. MEASUREMENT AND PAYMENT

Dynamic Message Sign (_____) will be measured and paid as the actual type and number of DMS furnished, installed, and accepted. Each DMS consists of a LED Dynamic Message Sign, spare

display modules, warranty, strapping hardware, controller, UPS, controller cabinet, concrete technician pad, conduit, fittings, couplings, sweeps, conduit bodies, wire, flexible conduit, feeder conductors and communications cable between the controller cabinet and the DMS enclosure, connectors, circuit protection equipment, photo-electric sensors, tools, materials, all related testing, cost of labor, cost of transportation, incidentals, and all other equipment necessary to furnish and install the DMS system.

Payment will be made under:

Pay Item	Pay Unit
Dynamic Message Sign (_____)	Each

28. NTCIP REQUIREMENTS

This section defines the NTCIP requirements for the DMSs covered by these Project Special Provisions and Project Plans.

28.1. References

A. Standards

This specification references several standards through their NTCIP designated names. The following list provides the full reference to the current version of each of these standards.

Implement the most recent version of the standard including any and all Approved or Recommended Amendments to these standards for each NTCIP Component covered by these project specifications. Refer to the NTCIP library at www.ntcip.org for information on the current status of NTCIP standards.

Abbreviated Number	Title
NTCIP 1201	<i>Global Object (GO) Definitions</i>
NTCIP 1203	<i>Object Definitions for Dynamic Message Signs</i>
NTCIP 2101	<i>SP-PMPP/232 Subnet Profile for PMPP over RS-232</i>
NTCIP 2104	<i>SP-Ethernet Subnet Profile for Ethernet</i>
NTCIP 2201	<i>TP-Null Transport Profile</i>
NTCIP 2202	<i>Internet Transport Profile (TCP/IP and UDP/IP)</i>

Abbreviated Number	Title
NTCIP 2301	<i>AP for Simple Transportation Management Framework</i>

B. Features

Each DMS shall be required to support the following optional features, conformance groups and all functional requirements and objects that apply herein.

Feature	Reference
Time Management	NTCIP 1201 v3
Timebase Event Schedule	NTCIP 1201 v3
PMPP	NTCIP 1201 v3
Determine Sign Display Capabilities	NTCIP 1203 v03
Manage Fonts	NTCIP 1203 v03
Manage Graphics	NTCIP 1203 v03
Schedule Messages for Display	NTCIP 1203 v03
Change Message Display Based on and Internal Event	NTCIP 1203 v03
Control External Devices	NTCIP 1203 v03
Monitor Sign Environment	NTCIP 1203 v03
Monitor Door Status	NTCIP 1203 v03
Monitor Controller Software Operations	NTCIP 1203 v03
Monitor Automatic Blanking of Sign	NTCIP 1203 v03
Report	NTCIP 1103 v03

C. Objects

The following table represents objects that are considered optional in the NTCIP standards but are required by this specification. It also indicated modified objects value ranges for certain objects. Each DMS shall provide the full, standard object range support (FSORS) of all the objects required by these specifications unless otherwise stated below.

Object	Reference	Requirement
moduleTable	NTCIP 1201 – 2.2.3	Shall contain at least one row with moduleType equal to 3 (software) The moduleMake specifies the name of the manufacturer, the moduleModel specifies the manufacturer's name of the component and the moduleVersion indicates the model version number of the component.

maxTimeBaseScheduleEntries	NTCIP 1201 – 2.4.3.1.	Shall be at least 28
maxDayPlans	NTCIP 1201 – 2.4.4.1	Shall be at least 20
maxDayPlanEvents	NTCIP 1201 – 2.4.4.2	Shall be at least 12
maxGroupAddresses	NTCIP 1201 – 2.7.1	Shall be at least 1
maxEventLogConfigs	NTCIP 1103 – A.7.4	Shall be at least 50
eventConfigMode	NTCIP 1103 – A.7.5.3	The DMS shall support the following Event Configurations: onChange, greaterThanValue, smallerThanValue
eventConfigLogOID	NTCIP 1103 – A.7.5.7	FSORS
eventConfigAction	NTCIP 1103 – A.7.5.8	FSORS
maxEventLogSize	NTCIP 1103 – A.7.6	Shall be at least 20
maxEventClasses	NCTIP 1103 – A.7.2	Shall be at least 16
eventClassDescription	NTCIP 1103 – A.7.3.4	FSORS
communityNamesMax	NTCIP 1103 – A.7.8	Shall be at least 3
numFonts	NTCIP 1203 – 5.4.1	Shall be at least 12
maxFontCharacters	NTCIP 1203 – 5.4.3	Shall be at least 255
defaultFlashOn	NTCIP 1203 – 5.5.3	The DMS shall support flash “on” times ranging from 0.1 to 9.9 seconds in 0.1 second increments
defaultFlashOnActive	NTCIP 1203 – 5.5.4	The DMS shall support flash “on” times ranging from 0.1 to 9.9 seconds in 0.1 second increments
defaultFlashOff	NTCIP 1203 - 5.5.5	The DMS shall support flash “off” times ranging from 0.1 to 9.9 seconds in 0.1 second increments
defaultFlassOffActive	NTCIP 1203 – 5.5.6	The DMS shall support flash “off” times ranging from 0.1 to 9.9 seconds in 0.1 second increments
defaultBackgroundColor	NTCIP 1203 – 5.5.2	The DMS shall support the black background color
defaultForegroundColor	NTCIP 1203 - 5.5.2	The DMS shall support the amber foreground color
defaultJustificationLine	NTCIP 1203 - 5.5.9	The DMS shall support the following forms of line justification: left, center, and right
defaultJustificationPage	NTCIP 1203 - 5.5.11	The DMS shall support the following forms of page justification: top, middle, and

		bottom
defaultPageOnTime	NTCIP 1203 - 5.5.13	The DMS shall support page “on” times ranging from 0.1 to 25.5 seconds in 0.1 second increments
defaultPageOffTime	NTCIP 1203 - 5.5.15	The DMS shall support page “off” times ranging from 0.0 to 25.5 seconds in 0.1 second increments
defaultCharacterSet	NTCIP 1203 - 5.5.21	The DMS shall support the eight bit character set
dmsMaxChangeableMsg	NTCIP 1203 - 5.6.3	Shall be at least 100.
dmsMessageMultiString	NTCIP 1203 - 5.6.8.3	The DMS shall support any valid MULTI string containing any subset of those MULTI tags listed in Table 3 (below)
dmsControlMode	NTCIP 1203 - 5.7.1	Shall support at least the following modes: local, central, and centralOverride
dmsSWReset	NTCIP 1203 - 5.7.2	FSORS
dmsMessageTimeRemaining	NTCIP 1203 - 5.7.4	FSORS
dmsShortPowerRecoveryMessage	NTCIP 1203 - 5.7.8	FSORS
dmsLongPowerRecoveryMessage	NTCIP 1203 - 5.7.9	FSORS
dmsShortPowerLossTime	NTCIP 1203 - 5.7.14	FSORS
dmsResetMessage	NTCIP 1203 - 5.7.11	FSORS
dmsCommunicationsLossMessage	NTCIP 1203 - 5.7.12	FSORS
dmsTimeCommLoss	NTCIP 1203 - 5.7.13	FSORS
dmsEndDurationMessage	NTCIP 1203 - 5.7.15	FSORS
dmsMultiOtherErrorDescription	NTCIP 1203 - 5.7.20	If the vendor implements any vendor-specific MULTI tags, the DMS shall provide meaningful error messages within this object whenever one of these tags generates an error
dmsIllumControl	NTCIP 1203 - 5.8.1	The DMS shall support the following illumination control modes: Photocell, and Manual
dmsIllumNumBrightLevels	NTCIP 1203 - 5.8.4	Shall be at least 100
dmsIllumLightOutputStatus	NTCIP 1203 - 5.8.9	FSORS
numActionTableEntries	NTCIP 1203 - 5.9.1	Shall be at least 200
watcdogFailureCount	NTCIP 1203 - 5.11.1.5	FSORS
dmsStatDoorOpen	NTCIP 1203 - 5.11.1.6	FSORS
fanFailures	NTCIP 1203 -	FSORS

	5.11.2.3.1	
fanTestActivation	NTCIP 1203 - 5.11.2.3.2	FSORS
tempMinCtrlCabinet	NTCIP 1203 - 5.11.4.1	FSORS
tempMaxCtrlCabinet	NTCIP 1203 - 5.11.4.2	FSORS
tempMinSignHousing	NTCIP 1203 - 5.11.4.5	FSORS
tempMaxSignHousing	NTCIP 1203 - 5.11.4.6	FSORS

D. MULTI Tags

Each DMS shall support the following message formatting MULTI tags. The manufacturer may choose to support additional standard or manufacturer specific MULTI tags.

Code	Feature
f1	field 1 - time (12hr)
f2	field 2 - time (24hr)
f8	field 8 – day of month
f9	field 9 – month
f10	field 10 - 2 digit year
f11	field 11 - 4 digit year
fl (and /fl)	flashing text on a line by line basis with flash rates controllable in 0.5 second increments.
fo	Font
jl2	Justification – line – left
jl3	Justification – line – center
jl4	Justification – line – right
jl5	Justification – line – full
jp2	Justification – page – top
jp3	Justification – page – middle
jp4	Justification – page – bottom
mv	moving text
nl	new line
np	new page, up to 2 instances in a message (i.e., up to 3 pages/frames in a message counting first page)
pt	page times controllable in 0.5 second increments.

E. Documentation

Supply software with full documentation, including a USB flash drive containing ASCII versions of the following MIB files in Abstract Syntax Notation 1 (ASN.1) format:

- The relevant version of each official standard MIB Module referenced by the device functionality.

- If the device does not support the full range of any given object within a Standard MIB Module, a manufacturer specific version of the official Standard MIB Module with the supported range indicated in ASN.1 format in the SYNTAX and/or DESCRIPTION fields of the associated OBJECT TYPE macro. Name this file identical to the standard MIB Module, except that it will have the extension ".man".
- A MIB Module in ASN.1 format containing any and all manufacturer-specific objects supported by the device with accurate and meaningful DESCRIPTION fields and supported ranges indicated in the SYNTAX field of the OBJECT-TYPE macros.
- A MIB containing any other objects supported by the device.

Allow the use of any and all of this documentation by any party authorized by the Department for systems integration purposes at any time initially or in the future, regardless of what parties are involved in the systems integration effort.

F. NTCIP Acceptance Testing

Test the NTCIP requirements outlined above by a third party testing firm. Submit to the Engineer for approval a portfolio of the selected firm. Include the name, address, and a history of the selected firm in performing NTCIP testing along with references. Also provide a contact person's name and phone number. Submit detailed NTCIP testing plans and procedures, including a list of hardware and software, to the Engineer for review and approval 10 days in advance of a scheduled testing date. Develop test documents based on the NTCIP requirements of these Project Special Provisions. The acceptance test will use the NTCIP Exerciser, and/or other authorized testing tools and will follow the guidelines established in the ENTERPRISE Test Procedures. Conduct the test in North Carolina on the installed system in the presence of the Engineer. Document and certify the results of the test by the firm conducting the test and submit the Engineer for review and approval. In case of failures, remedy the problem and have the firm retest in North Carolina. Continue process until all failures are resolved. The Department reserves the right to enhance these tests as deemed appropriate to ensure device compliance.

28.2. Measurement and Payment

There will be no direct payment for the work covered by this section.

Payment for this work will be covered in the applicable sections of these Project Special Provisions at the contract unit price for "Dynamic Message Sign ()" and will be full compensation for all work listed above.

29. DMS PEDESTAL STRUCTURE

29.1. DESCRIPTION

This section includes all design, fabrication, furnishing, and erection of the DMS pedestal structure, platforms, walkways, ladders for access to the DMS inspection doors, and attachment of the DMS enclosures to the structure in accordance with the requirements of these Project Special Provisions and the Project Plans. Fabricate the supporting DMS assemblies from tubular steel. Furnish pedestal type DMS assemblies as shown in the Project Plans.

Provide pedestal DMS structures with a minimum clearance from the high point of the road to the bottom of the DMS enclosure of 25 feet for Walk-In DMS and 20 feet for Front Access DMS.

Design the new DMS assemblies (including footings), DMS mounting assemblies, maintenance platforms, and access ladders and submit shop drawings for approval. A Professional Engineer that

is registered in the state of North Carolina will prepare such computations and drawings. These must bear his signature, seal, and date of acceptance.

The provisions of Section 900 of the *Standard Specifications* apply to all work covered by this section.

The Standard Provisions SP09R005 and SP09R007 found at the link below apply to all work covered by this section.

<https://connect.ncdot.gov/resources/Specifications/Pages/2024-Specifications-and-Special-Provisions.aspx>

It is the Contractor's responsibility to verify DMS S-dimension elevation drawings for the DMS locations and provide them with the DMS shop drawings for the Engineer's approval.

29.2. MATERIALS

Use materials that meet the requirements of:

- Section 906 of the *2024 Standard Specification for Roads and Structures*.
- Standard Provision SP09R005 *Foundations and Anchor Rod Assemblies for Metal Poles*.
- Standard Provision SP09R007 *Overhead and Dynamic Message Sign Foundations*.

29.3. CONSTRUCTION METHODS

A. General

Construct DMS structures and assemblies in accordance with the requirements of:

- Section 906 of the *2024 Standard Specification for Roads and Structures*.
- Standard Provision SP09R005 *Foundations and Anchor Rod Assemblies for Metal Poles*.
- Standard Provision SP09R007 *Overhead and Dynamic Message Sign Foundations*.

B. DMS Maintenance Platform (Walkway)

Provide a maintenance platform (walkway), a minimum of three feet wide with open skid resistant surface and safety railing on the DMS assemblies for access to one of the DMS inspection doors as shown on the plans. Provide platforms with fixed safety railings along both sides from the beginning of the platform to the inspection door. No gap is allowed between walkway and inspection door or along any part of the safety rails.

Ensure the design, fabrication and installation of the access platforms on new DMS structures complies with the following:

- A. The top of the platform grading surface is vertically aligned with the bottom of the DMS door,
- B. The DMS door will open 90-degrees from its closed position without any obstruction from the platform or safety handrails,
- C. The platform is rigidly and directly connected to the walkway brackets and there is no uneven surface between sections,

- D. Install a 4" x 4" safety angle parallel to and along both sides of the platform and extend it the entire length of the platform. Design the safety angle to withstand loading equivalent to the platform,
- E. Ensure the platform design allows full access to the DMS enclosure inspection door with no interference or obstructions.

C. DMS Access Ladder

Provide a fixed ladder, of the same material as the pedestal structures, leading to and ending at the access platform. Equip the ladder with a security cover (ladder guard) and lock to prohibit access by unauthorized persons. Furnish the lock to operate with a Corbin #2 key and furnish two keys per lock. Design the rungs on 12-inch center to center typical spacing. Start the first ladder rung no more than 18 inches above the landing pad. Attach the security cover approximately 6 feet above the finished ground. Design the ladder and security cover as a permanent part of the DMS assembly and include complete design details in the DMS assembly shop drawings. Fabricate the ladder and cover to meet all OSHA requirements and applicable state and local codes, including but not limited to providing a ladder cage.

Furnish and install a level concrete pad a minimum of 4 inches deep, 24 inches wide, and 36 inches long to service as a landing pad for accessing the ladder. Design the landing pad to be directly below the bottom rung. Access to the ladder shall not be obstructed by the DMS foundation. Provide pre-formed or cast-in place concrete pads.

29.4. MEASUREMENT AND PAYMENT

DMS Pedestal Structure will be measured and paid as the actual number of dynamic message sign pedestal structure assemblies furnished, installed, and accepted. Payment includes all design, fabrication, construction, transportation, and attachment of the complete relocated dynamic message sign assemblies, supporting structure, hardware, access platform, direct tension indicators, preparing and furnishing shop drawings, additional documentation, incidentals, and all other equipment and features necessary to furnish the system described above.

DMS Access Ladder will be measured and paid as the actual number of DMS access ladders, platform, walkway furnished, installed and accepted. Payment includes design, fabrication, transportation, attachment to the DMS assembly as described above, lock with two keys each, and concrete pad.

Overhead Footings will be measured and paid in cubic yards and will be full compensation for all materials and labor required in *Overhead and Dynamic Message Sign Foundations (SP09 R007)* and *Foundations and Anchor Rod Assemblies for Metal Poles (PS09 R005)* referred in the link above. Payment will be made according to PS09 R007

The contract unit price for Overhead Footings will be full compensation for providing labor, tools, equipment and foundation materials, stabilizing or shoring excavations, supplying and placing concrete, reinforcing steel, conduit, anchor rod assemblies and any incidentals necessary to construct sign foundations. Subsurface investigations required by the Engineer will be paid as extra work in accordance with Article 104-7 of the *2024 Standard Specifications for Roads and Structures*.

Payment will be made under:

Pay Item	Pay Unit
DMS Pedestal Structure	Each
DMS Access Ladder	Each

30. ELECTRICAL SERVICE FOR ITS DEVICES

30.1. DESCRIPTION

Install new electrical service equipment as shown in the plans. Installation of all new electrical service pedestals, poles, and meter base/disconnect combination panels shall be the first item of work on this project to expedite the power service connections. Comply with the National Electrical Code (NEC), the National Electrical Safety Code (NESC), the Standard Specifications, the Project Special Provisions, and all local ordinances. All work involving electrical service shall be coordinated with the appropriate utility company and the Engineer.

Obtain the maximum available ground fault current from the utility company. Print this information on a durable label and adhere to the dead front of the disconnect.

30.2. MATERIAL

A. Meter Base/Disconnect Combination Panel

Furnish and install new meter base/disconnect combination panels as shown in the Plans. Provide meter base/disconnect combination panels that have a minimum 125A main service disconnect and a minimum of eight (8) additional spaces. Furnish a single pole 15A circuit breaker at CCTV locations. Furnish a double pole 50A circuit breakers at single DMS locations. Furnish a double pole 100A circuit breakers at dual DMS locations. Furnish each with a minimum of 10,000 RMS symmetrical amperes short circuit current rating in a lockable NEMA 3R enclosure. Ensure meter base/ disconnect combination panel is listed as meeting UL Standard UL-67 and marked as being suitable for use as service equipment. Ensure circuit breakers are listed as meeting UL-489. Place barriers so that no uninsulated, ungrounded service busbar or service terminal is exposed to inadvertent contact by persons or maintenance equipment while servicing load terminations. Fabricate enclosure from galvanized steel and electrostatically apply dry powder paint finish, light gray in color, to yield a minimum thickness of 2.4 mils. All exterior surfaces must be powder coated steel. Provide ground bus and neutral bus with a minimum of four terminals and a minimum wire capacity range of number 8 through number 3/0 AWG.

Furnish NEMA Type 3R combinational panels rated 100 Ampere minimum for overhead services and 200 Ampere minimum for underground services that meet the requirements of the local utility. Provide meter base with sockets' ampere rating based on sockets being wired with a minimum of 167 degrees F insulated wire. Furnish 4 terminal, 600 volt, single phase, 3-wire meter bases that comply with the following:

- Line, Load, and Neutral Terminals accept 4/0 AWG and smaller Copper/Aluminum wire
- With or without horn bypass

- Made of galvanized steel
- Listed as meeting UL Standard US-414
- Overhead or underground service entrance specified.

Furnish 1.5” watertight hub for threaded rigid conduit with meter base.

At the main service disconnect, furnish and install UL-approved lightning arrestors that meet the following requirements:

Type of design	Silicon Oxide Varistor
Voltage	120/240 Single Phase, 3 wire
Maximum current	100,000 amps
Maximum energy	3000 joules per pole
Maximum number of surges	Unlimited
Response time one milliamp test	5 nanoseconds
Response time to clamp 10,000 amps	10 nanoseconds
Response time to clamp 50,000 amps	25 nanoseconds
Leak current at double the rated voltage	None
Ground wire	Separate

B. Equipment Cabinet Disconnect

Provide new equipment cabinet disconnects at the locations shown in the Plans. Furnish a single pole 15A circuit breaker at CCTV locations. Furnish double pole 50A circuit breaker at single DMS locations. Furnish double pole 100A circuit breaker at dual DMS locations. Furnish panels that have a minimum of four (4) spaces in the disconnect. Furnish circuit breakers with a minimum of 10,000 RMS symmetrical amperes short circuit current rating in a lockable NEMA 3R enclosure. Ensure meter base/ disconnect combination panel is listed as meeting UL Standard UL-67 and marked as being suitable for use as service equipment. Ensure circuit breakers are listed as meeting UL-489. Fabricate enclosure from galvanized steel and electrostatically apply dry powder paint finish, light gray in color, to yield a minimum thickness of 2.4 mils. All exterior surfaces must be powder coated steel. Provide ground bus and neutral bus with a minimum of four terminals and a minimum wire capacity range of number 8 through number 3/0 AWG.

C. 10KVA Single Phase General Purpose Transformer

As shown on the Plans, furnish and install a double-wound, dry type general purpose transformer to isolate the line side voltages from the load side voltages as shown in the Plans. Provide the transformer with the following specifications:

- Primary Volts: 120/240 with 83/41 Amps Max. 60Hz.
- Secondary Volts: 120/240 with 83/41 Amps Max. 60Hz.

- 10 kVA power rating.
- Electrostatic shielding between primary and secondary windings.
- Epoxy-silica encapsulated core and coil.
- Copper windings and copper lead wire terminations.
- Multiple front and bottom knockout for conduit entry/exit.
- Ground studs for conduit bonding.

Provide the transformer in a NEMA 3R enclosure suitable for mounting to a metal or wood pole.

D. 3-Wire Copper Service Entrance Conductors

Furnish 3-wire stranded copper service entrance conductors with THWN rating. Provide conductors with black, red, and white insulation that are intended for power circuits at 600 Volts or less and comply with the following:

- Listed as meeting UL Standard UL-83
- Meets ASTM B-3 and B-8 or B-787 standards.

See the Plans for wire sizes and quantities.

E. 3-Wire Copper Feeder Conductors

Furnish 3-wire stranded copper feeder conductors with THWN rating for supplying power to ITS field equipment cabinets. Provide conductors with black or red, white, and green insulation that are intended for power circuits at 600 Volts or less and comply with the following:

- Listed as meeting UL Standard UL-83
- Meets ASTM B-3 and B-8 or B-787 standards.

See the Plans for wire sizes and quantities.

F. 4-Wire Copper Feeder Conductors

Furnish 4-wire stranded copper feeder conductors with THWN rating for supplying power to DMS field equipment cabinets. Provide conductors with black, red, white, and green insulation that are intended for power circuits at 600 Volts or less and comply with the following:

- Listed as meeting UL Standard UL-83
- Meets ASTM B-3 and B-8 or B-787 standards.

See the Plans for wire sizes and quantities.

G. Grounding System

Furnish 5/8"x10' copper clad steel grounding electrodes (ground rods), #4 AWG solid bare copper conductors. Comply with the NEC, Standard Specifications, these Project Special Provisions, and the Plans.

30.3. CONSTRUCTION METHODS

A. General

Coordinate with the Engineer and the utility company to de-energize the existing service temporarily prior to starting any modifications.

Permanently label cables at all access points using nylon tags labeled with permanent ink. Ensure each cable has a unique identifier. Label cables immediately upon installation. Use component name and labeling scheme approved by the Engineer.

B. Meter Base/Disconnect Combination Panel

Install meter base/disconnect combination panels with lightning arrestors as called for in the Plans. At all new DMS locations, route the feeder conductors from the meter base/disconnect to the DMS equipment cabinet in conduit. At all new CCTV locations, route the feeder conductors from the meter base/disconnect to the CCTV equipment cabinet in conduit. Provide rigid galvanized conduit for above ground and PVC for below ground installations.

C. Electrical Service Disconnect

Install equipment cabinet disconnects and circuit breakers as called for in the Plans. Install THWN stranded copper feeder conductors as shown in Plans between the electrical service disconnect and the equipment cabinet disconnect. Route the conductors from the equipment cabinet disconnect to the equipment cabinet in rigid galvanized steel conduit. Bond the equipment cabinet disconnect in accordance with the NEC. Ensure that the grounding system complies with the grounding requirements of these Project Special Provisions, the Standard Specifications and the Plans.

D. 10KVA Single Phase General Purpose Transformer

As shown on the Plans, furnish and install a single phase general purpose transformer in a NEMA 3R enclosure. Route the conductors from the transformer secondary to the DMS equipment cabinet or equipment cabinet disconnect in rigid galvanized conduit. Bond the equipment cabinet disconnect in accordance with the NEC. Provide all mounting hardware and other parts and labor necessary to successfully install the transformer.

E. 3-Wire Copper Service Entrance Conductors

At locations shown in the Plans, furnish and install 3-wire THWN stranded copper service entrance conductors in 1.25 inch rigid galvanized risers as shown in the plans. Install a waterproof hub on top of the electrical service disconnect for riser entrance/exit. Size the conductors as specified in the Plans. Comply with the Standard Specifications and Standard Drawings and all applicable electrical codes.

F. 4-Wire Copper Feeder Conductors

At locations shown in the Plans, install 4-wire THWN stranded copper feeder conductors to supply 240/120 VAC to the DMS field equipment cabinets. Size the conductors as specified in the Plans. Comply with the Standard Specifications and Standard Drawings and all applicable electrical codes.

G. 3-Wire Copper Feeder Conductors

At locations shown in the Plans, install 3-wire THWN stranded copper feeder conductors to supply 120 VAC to the CCTV field equipment cabinets. Size the conductors as specified in the Plans. Comply with the Standard Specifications and Standard Drawings and all applicable electrical codes.

H. Grounding System

Install ground rods as indicated in the Plans. Connect the #4 AWG grounding conductor to ground rods using an irreversible mechanical crimping method. Test the system to ensure a ground resistance of 20-ohms or less is achieved. Drive additional ground rods as necessary or as directed by the Engineer to achieve the proper ground resistance.

30.4. MEASUREMENT AND PAYMENT

Meter base/disconnect combination panel will be measured and paid as the actual number of complete and functional meter base/disconnect combination panel service locations furnished, installed and accepted. Breakers, lightning arrestors, exposed vertical conduit runs to the cabinet, and any remaining hardware, fittings, and conduit bodies to connect the electrical service to the cabinet will be considered incidental to meter base/disconnect combination panels.

3-Wire copper service entrance conductors will be incidental to furnish and installing the meter base/disconnect combination panel. All other required feeder conductors will be paid for separately.

Equipment cabinet disconnect will be measured and paid as the actual number of complete and functional equipment cabinet disconnects furnished, installed and accepted. Breakers, exposed vertical conduit runs to the cabinet, ground rods, ground wire and any remaining hardware and conduit to connect the equipment cabinet disconnect to the cabinet will be considered incidental to the equipment cabinet subpanel.

10KVA Transformer will be measured and paid in actual number of complete and functional 10KVA transformers furnished, installed and accepted. Enclosures, mounting hardware, pre-formed pad, and any remaining hardware, fittings, and conduit bodies to connect the isolation transformer will be considered incidental to the 10KVA transformer and will be considered incidental to the 10KVA transformer.

4-Wire copper feeder conductors will be measured and paid as the actual linear feet of 4-wire THWN stranded copper feeder conductors furnished, installed and accepted. Payment is for all four conductors. Measurement will be for the actual linear footage of combined conductors after all terminations are complete. No separate payment will be made for each individual conductor. No separate payment will be made for different wire sizes. No payment will be made for excess wire in the cabinets.

3-Wire copper feeder conductors will be measured and paid as the actual linear feet of 3-wire THWN stranded copper feeder conductors furnished, installed and accepted. Payment is for all three conductors. Measurement will be for the actual linear footage of combined conductors after all terminations are complete. No separate payment will be made for each individual conductor. No separate payment will be made for different wire sizes. No payment will be made for excess wire in the cabinets.

5/8" X 10' grounding electrode (ground rod) will be measured and paid as the actual number of 5/8" copper clad steel ground rods furnished, installed and accepted. No separate payment will be made for irreversible mechanical crimping tool as this will be considered incidental to the installation of the ground rod.

#4 solid bare grounding conductor will be measured and paid as the actual linear feet of #4 AWG solid bare copper grounding conductor furnished, installed and accepted. Measurement will be along the approximate centerline from the base of the electrical service disconnect to the last grounding electrode.

Payment will be made under:

Pay Item	Pay Unit
Meter Base/Disconnect Combination Panel	Each
Equipment Cabinet Disconnect.....	Each
10KVA Single Phase Transformer	Each
3-Wire Copper Service Entrance Conductors.....	Linear Foot
4-Wire Copper Feeder Conductors	Linear Foot
3-Wire Copper Feeder Conductors	Linear Foot
5/8" X 10' Grounding Electrode.....	Each
#4 Solid Bare Grounding Conductor	Linear Foot

31. SOLAR POWER ASSEMBLY

31.1. DESCRIPTION

Install new solar power assembly equipment with equipment cabinets and all necessary hardware in accordance with these Project Special Provisions and the Plans. Comply with the provisions of Section 1700 of the Standard Specifications.

31.2. MATERIAL

Furnish and install a solar power assembly at the locations shown in the Plans consisting of the following:

- Solar Array
- Solar Charge Controller
- Batteries
- Assembly Cabinet
- Concrete Cabinet Pad

A. Solar Array

Furnish solar modules made in North America and have a minimum 20 year factory warranty. The solar array should have a minimum peak output of 100W. Solar modules must be UL listed, FM Class I, Div II, Group C & D approved. For the solar array, power wiring should be 10-2, stranded copper, double insulated, sunlight resistant, 600V 90C rated cable. The array mount will attach to the side of the CCTV pole with stainless steel fasteners. The array mount must be aluminum alloy or stainless steel. The array must be capable of withstanding 125 mph winds.

B. Solar Charge Controller

Furnish solar charge controllers that are UL listed, a minimum 45A with solid state, low voltage disconnects. Ensure that the solar charge regulator is sealed with internal temperature compensation, lightning protection, reverse polarity protection, and LED indicators. Provide controllers with the capability of 3 functions: battery charging, load control, and diversion regulation. Controllers must be furnished with fully adjustable DIP switches and RS-232 communications port to adjust the unit's operational modes. Ensure the solar charge regulator is FMS Class I, Groups ABCD and have the CE mark.

C. Batteries

Provide 12V gel electrolyte, non-spillable, maintenance free batteries. Furnish batteries capable of providing power for 10 days without being charged by the Solar Array and Solar Charge Controller. Furnish batteries with a minimum operating temperature of -76° F to 140°F.

D. Solar Power Assembly Cabinet

Furnish a solar power assembly cabinet constructed of 0.125" aluminum with stainless steel hardware. There must be separate compartments for the batteries and the electronics. The enclosures must be NEMA 3R rated and large enough to contain all solar equipment and incidental components, including 20% spare space. Mount the solar power assembly cabinet on a concrete pad.

31.3. CONSTRUCTION METHODS

Furnish and install new solar power assemblies. Install solar power equipment as shown in the Plans. Provide wiring, disconnects, and all other required equipment as required by Article 690 of the NEC.

Install solar panel collectors at a height that will prohibit theft and/or vandalism. At a minimum, mount the solar panel collectors 20 feet from ground level. Installation of multiple collector panels shall be approved by the Engineer prior to installation.

Ensure that the maximum resistance between the grounding electrode and all points in the grounding system does not exceed 5 ohms.

In addition to the requirements of the NEC, test grounding electrode resistance at the connection point to the electrical service ground bus for a maximum of 20 ohms. Furnish and install ground rods to the grounding electrode system as necessary to meet the test requirements.

After replacing the components, ensure the solar power assembly will fulfil the original design requirements, specifically:

- Fully powering the CCTV camera and communications equipment operating 24 hours a day with 50% of that time being in a standby (sleep) mode; and 50% of the time being in operational mode.
- The solar array is properly supplying input to the battery charging components.
- Supplying power sufficient to operate the ITS installation for 10 days without solar array input.

Ensure that the equipment cabinet along with solar array(s) and its mounting hardware are capable of surviving sustains winds of 140 MPH. Ensure the solar array(s) does not obstruct the view of traffic and that the array(s) are arranged for optimal sunlight exposure for charging of the battery(ies). Mount the array(s) at a minimum height of 25 feet above ground level.

Run field wiring from the solar power array(s) to the equipment cabinet through 1 inch riser with weatherhead and make connections inside the equipment cabinets as required. Install separate DC disconnects between the solar array and the solar charger controller and between the solar charger controller and the battery(ies), and between the battery(ies) and any other equipment. Ensure the DC disconnect allows personnel working on the system to safely isolate critical items from each other while performing maintenance and trouble shooting. Ensure that all wiring including grounding of the solar photovoltaic system meets the requirements of Article 690 of the National Electric Code (NEC) and these project special provisions.

To protect against high voltage power surges, furnish and install one grounding electrode at the equipment cabinet.

Terminate all wires using spade connectors under binding screws on terminal blocks. Label all terminal blocks and terminals for easy identification. Label all wires and harnesses for easy identification. Neatly secure all wiring and harness inside the cabinet in a method approved by the Engineer.

Provide and leave all data interface cables, installation manuals, and specifications and materials used to program any equipment in the Equipment Cabinet. Program all equipment for operation.

31.4. MEASUREMENT AND PAYMENT

Solar Power Assembly will be measured and paid as the actual number of solar power assemblies furnished, installed and accepted.

No separate measurement will be made for solar arrays, solar power assembly equipment cabinet, solar panels, solar panel mounting hardware, charge controllers, installing breakers, inverters, temperature sensors, concrete cabinet pad, mounting system, grounding system, conduits, risers, wiring, and hardware as these will be considered incidental to furnishing and installing the solar power assembly.

Payment will be made under:

Pay Item	Pay Unit
Solar Power Assembly	Each

32. OBSERVATION PERIOD FOR ITS DEVICES

32.1. 30-DAY OBSERVATION PERIOD

The 30-Day Observation Period shall be considered part of work to be completed by the project completion date.

Upon successful completion of all project work the 30-day Observation Period may commence. Examples of project work includes but is not limited to:

- Installation of all project devices and communications infrastructure.
- Field Acceptance Testing of all devices.
- Central System Testing of all devices and network communications.
- Correction of all deficiencies and punch list items. (including minor construction items)

This observation consists of a 30-day period of normal, day-to-day operations of the field equipment in operation with new or existing central equipment without any failures. The purpose of

this period is to ensure that all components of the system function in accordance with the Plans and these Project Special Provisions.

Respond to system or component failures (or reported failures) that occur during the 30-day Observation Period within twenty-four (24) hours. Correct any failures within forty-eight (48) hours (includes time of notification). Any failure that affects a major system component as defined below for more than forty-eight (48) hours will suspend the timing of the 30-day Observation Period beginning at the time when the Contractor is was notified that the failure occurred. After the cause of such failures has been corrected, timing of the 30-day Observation Period will resume. System or component failures that necessitate a redesign of any component or a failure in any of the major system components exceeding a total of three (3) occurrences will terminate the 30-day Observation Period for that system. The 30-day Observation Period will be restarted from day zero when the redesigned components have been installed and/or the failures corrected. The major system components are:

- CCTV Cameras and Central Operations
- Dynamic Message Sign (DMS) and Central equipment/Operations
- Portable Changeable Message Sign (PCMS)
- Communications infrastructure (examples: Fiber, Radios, Ethernet Switches, Core Switches, etc.)
- Any other ITS Devices not named above (examples: DSRC radios, Radar and Out-of-Street Detection, etc.)

32.2. FINAL ACCEPTANCE

Final system acceptance is defined as the time when all work and materials described in the Plans and these Project Special Provisions have been furnished and completely installed by the Contractor; all parts of the work have been approved and accepted by the Engineer; and successful completion of the 30-day observation period.

The completed System will be ready for final acceptance upon the satisfactory completion of all acceptance tests as detailed in their respective Section of the Project Special provisions; the rectification of all punch-list discrepancies; and the submittal of all project documentation including as-built plans.

32.3. MEASUREMENT AND PAYMENT

There will be no payment for this item of work as it is incidental to the project as a whole and to the item of work in which it is associated.